

SECTION **CL**
CLUTCH

A
B
C

CL

CONTENTS

E

SYMPTOM DIAGNOSIS	2	Removal and Installation	11	F
NOISE, VIBRATION AND HARSHNESS (NVH) TROUBLESHOOTING	2	Inspection and Adjustment	12	
NVH Troubleshooting Chart	2	CLUTCH MASTER CYLINDER	13	G
PRECAUTION	3	Exploded View	13	
PRECAUTIONS	3	Removal and Installation	13	
Precaution for Supplemental Restraint System (SRS) "AIR BAG" and "SEAT BELT PRE-TENSIONER"	3	Inspection and Adjustment	14	H
Precaution Necessary for Steering Wheel Rotation after Battery Disconnect	3	CLUTCH PIPING	15	
Service Notice or Precautions for Clutch	4	Exploded View	15	
PREPARATION	5	Hydraulic Layout	15	I
PREPARATION	5	Removal and Installation	15	
Special Service Tools	5	Inspection and Adjustment	16	J
Commercial Service Tools	5	UNIT REMOVAL AND INSTALLATION	17	
PERIODIC MAINTENANCE	6	CSC (CONCENTRIC SLAVE CYLINDER)	17	K
CLUTCH PEDAL	6	Exploded View	17	
Inspection and Adjustment	6	Removal and Installation	17	
CLUTCH FLUID	8	Inspection and Adjustment	17	L
Inspection	8	CLUTCH DISC AND CLUTCH COVER	18	
Draining	8	Exploded View	18	
Refilling	9	Removal and Installation	18	M
Air Bleeding Procedure	10	Inspection	19	
REMOVAL AND INSTALLATION	11	SERVICE DATA AND SPECIFICATIONS (SDS)	21	N
CLUTCH PEDAL	11	SERVICE DATA AND SPECIFICATIONS (SDS)	21	
Exploded View	11	Clutch Control System	21	O
		Clutch Pedal	21	
		Clutch Disc	21	P
		Clutch Cover	21	

NOISE, VIBRATION AND HARSHNESS (NVH) TROUBLESHOOTING

< SYMPTOM DIAGNOSIS >

SYMPTOM DIAGNOSIS

NOISE, VIBRATION AND HARSHNESS (NVH) TROUBLESHOOTING

NVH Troubleshooting Chart

INFOID:000000004875823

Use the chart below to find the cause of the symptom. The numbers indicate the order of the inspection. If necessary, repair or replace these parts.

SYMPTOM		SUSPECTED PARTS (Possible cause)														
		CLUTCH PEDAL (Inspection and adjustment)	CLUTCH LINE (Air in line)	ENGINE MOUNTING (Loose)	CSC (Concentric Slave Cylinder) (Worn, dirty or damaged)	CLUTCH DISC (Out of true)	CLUTCH DISC (Runout is excessive)	CLUTCH DISC (Lining broken)	CLUTCH DISC (Dirty or burned)	CLUTCH DISC (Oily)	CLUTCH DISC (Worn out)	CLUTCH DISC (Hardened)	CLUTCH DISC (Lack of spline grease)	DIAPHRAGM SPRING (Damaged)	DIAPHRAGM SPRING (Out of tip alignment)	PRESSURE PLATE (Distortion)
Reference		CL-6	CL-10	EM-74	CL-17					CL-18						EM-95
Symptom	Clutch grabs/chatters			1			2			2	2	2			2	
	Clutch pedal spongy		1		2											
	Clutch noisy				1											
	Clutch slips	1								2	2			3		4 5
	Clutch does not disengage	1	2		3	3	3	3	3	3			3	4	4	5

PRECAUTIONS

< PRECAUTION >

PRECAUTION

PRECAUTIONS

Precaution for Supplemental Restraint System (SRS) "AIR BAG" and "SEAT BELT PRE-TENSIONER"

INFOID:000000005095282

The Supplemental Restraint System such as "AIR BAG" and "SEAT BELT PRE-TENSIONER", used along with a front seat belt, helps to reduce the risk or severity of injury to the driver and front passenger for certain types of collision. This system includes seat belt switch inputs and dual stage front air bag modules. The SRS system uses the seat belt switches to determine the front air bag deployment, and may only deploy one front air bag, depending on the severity of a collision and whether the front occupants are belted or unbelted. Information necessary to service the system safely is included in the "SRS AIR BAG" and "SEAT BELT" of this Service Manual.

WARNING:

- To avoid rendering the SRS inoperative, which could increase the risk of personal injury or death in the event of a collision which would result in air bag inflation, all maintenance must be performed by an authorized NISSAN/INFINITI dealer.
- Improper maintenance, including incorrect removal and installation of the SRS, can lead to personal injury caused by unintentional activation of the system. For removal of Spiral Cable and Air Bag Module, see the "SRS AIR BAG".
- Do not use electrical test equipment on any circuit related to the SRS unless instructed to in this Service Manual. SRS wiring harnesses can be identified by yellow and/or orange harnesses or harness connectors.

PRECAUTIONS WHEN USING POWER TOOLS (AIR OR ELECTRIC) AND HAMMERS

WARNING:

- When working near the Air Bag Diagnosis Sensor Unit or other Air Bag System sensors with the ignition ON or engine running, DO NOT use air or electric power tools or strike near the sensor(s) with a hammer. Heavy vibration could activate the sensor(s) and deploy the air bag(s), possibly causing serious injury.
- When using air or electric power tools or hammers, always switch the ignition OFF, disconnect the battery, and wait at least 3 minutes before performing any service.

Precaution Necessary for Steering Wheel Rotation after Battery Disconnect

INFOID:000000005096898

NOTE:

- Before removing and installing any control units, first turn the push-button ignition switch to the LOCK position, then disconnect both battery cables.
- After finishing work, confirm that all control unit connectors are connected properly, then re-connect both battery cables.
- Always use CONSULT-III to perform self-diagnosis as a part of each function inspection after finishing work. If a DTC is detected, perform trouble diagnosis according to self-diagnosis results.

This vehicle is equipped with a push-button ignition switch and a steering lock unit.

If the battery is disconnected or discharged, the steering wheel will lock and cannot be turned.

If turning the steering wheel is required with the battery disconnected or discharged, follow the procedure below before starting the repair operation.

OPERATION PROCEDURE

1. Connect both battery cables.

NOTE:

Supply power using jumper cables if battery is discharged.

2. Turn the push-button ignition switch to ACC position.
(At this time, the steering lock will be released.)
3. Disconnect both battery cables. The steering lock will remain released with both battery cables disconnected and the steering wheel can be turned.
4. Perform the necessary repair operation.

PRECAUTIONS

< PRECAUTION >

5. When the repair work is completed, re-connect both battery cables. With the brake pedal released, turn the push-button ignition switch from ACC position to ON position, then to LOCK position. (The steering wheel will lock when the push-button ignition switch is turned to LOCK position.)
6. Perform self-diagnosis check of all control units using CONSULT-III.

Service Notice or Precautions for Clutch

INFOID:000000004875826

WARNING:

After cleaning clutch disc, wipe it with a dust collector. Never use compressed air.

CAUTION:

- Recommended clutch fluid is brake fluid "DOT 3". Refer to [MA-10, "Fluids and Lubricants"](#).
- Never reuse drained clutch fluid.
- Never splash clutch fluid on painted areas.
- Keep painted surface on the body or other parts free of clutch fluid. If it spills, wipe up immediately and wash the affected area with water.
- Never use mineral oils such as gasoline or kerosene. It will ruin the rubber parts of the hydraulic system.
- Never reuse CSC (Concentric Slave Cylinder). Because CSC slides back to the original position every time when removing transaxle assembly. At this timing, dust on the sliding parts may damage a seal of CSC and may cause clutch fluid leakage. Refer to [CL-17, "Removal and Installation"](#).
- Never disassemble master cylinder and CSC.

PREPARATION

< PREPARATION >

PREPARATION

PREPARATION

Special Service Tools

INFOID:0000000004875996

The actual shapes of Kent-Moore tools may differ from those of special service tools illustrated here.

Tool number (Kent-Moore No.) Tool name	Description
ST20050240 (-) Diaphragm adjusting wrench  ZZA0508D	Adjusting unevenness of diaphragm spring lever

Commercial Service Tools

INFOID:0000000004875997

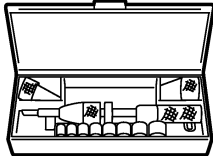
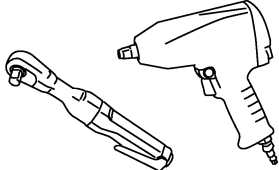
Tool name	Description
Clutch aligner  MCIB0404E	Installing clutch disc
Power tool  PBIC0190E	Loosening bolts and nuts

CLUTCH PEDAL

< PERIODIC MAINTENANCE >

PERIODIC MAINTENANCE

CLUTCH PEDAL

Inspection and Adjustment

INFOID:000000004876000

INSPECTION

The Height of Clutch Pedal

1. Turn the floor carpet.
2. Check that the clutch pedal height "H₁" from the dash lower panel (1) is within the reference value.

Clutch pedal height "H₁" : Refer to [CL-21, "Clutch Pedal"](#).

3. Replace clutch pedal if the height is outside the reference value.

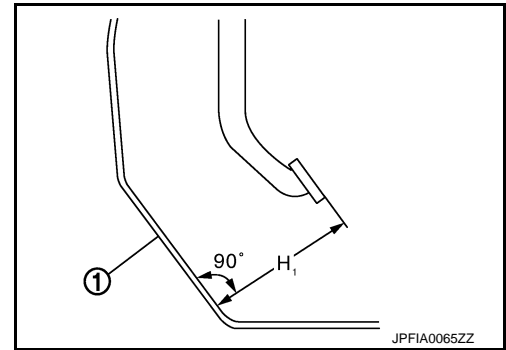

Clutch Pedal Height When Disengaging The Clutch

1. Turn the floor carpet.
2. Start the engine and run at idle.
3. Apply the parking brake.
4. Depress the brake pedal.
5. Fully depress clutch pedal and shift to the 1st gear.
6. Gradually release the clutch pedal and check that the clutch pedal height "H₂" from the dash lower panel (1) is within the reference value with a scale immediately before the clutch is engaged.

Clutch pedal height at clutch disengagement "H₂" : Refer to [CL-21, "Clutch Pedal"](#).

NOTE:

Although the clutch pedal height differs according to whether the clutch gets disengaged or engaged, clutch-engaged case is regarded as clutch-disengaged case for easier inspection.

7. Replace clutch pedal if the height is outside the reference value.

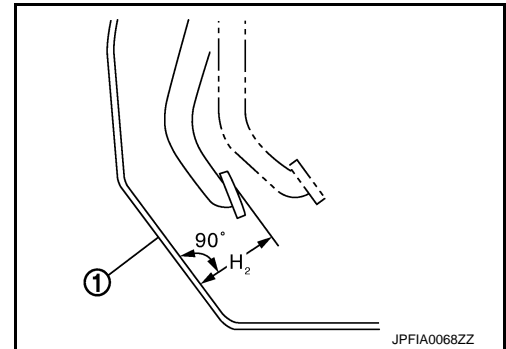

Clutch Pedal Play

1. Push the pedal pad by hand until a resistance can be felt and check that the play "A" on the upper surface of the pedal pad is within the reference value.

Clutch pedal play "A" : Refer to [CL-21, "Clutch Pedal"](#).

2. Replace clutch pedal if the play is outside the reference value.

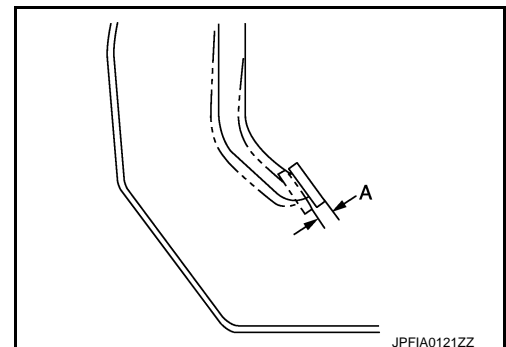

Position of Clutch Switch

CLUTCH PEDAL

< PERIODIC MAINTENANCE >

Check that the clearance "C" between the thread end of clutch switch (1) and stopper rubber (2) is within the specified value while clutch pedal is fully depressed.

Clearance "C" : Refer to [CL-21, "Clutch Pedal"](#).

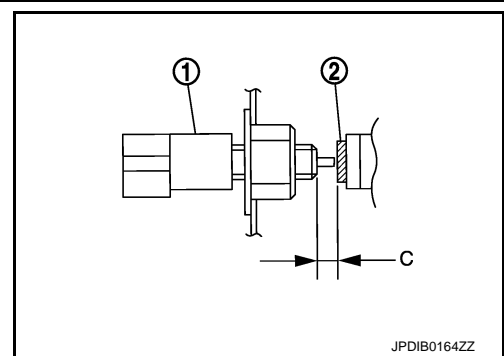

Position of ASCD Clutch Switch (With ASCD)

Check that the clearance "A" between the thread end of ASCD clutch switch (1) and clutch pedal (2) is within the specified value while clutch pedal is fully released.

Clearance "A" : Refer to [CL-21, "Clutch Pedal"](#).

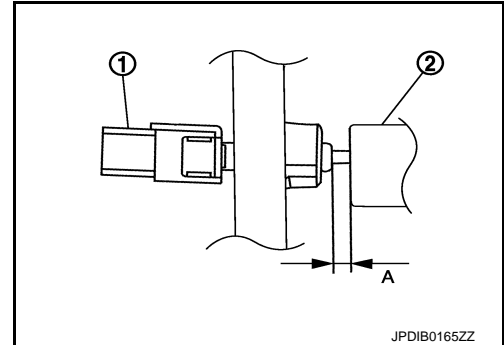

ADJUSTMENT

Position of Clutch Switch

1. Loosen clutch switch by turning it 45 degrees counterclockwise.
2. Press the clutch switch (1) to bring clearance "C" between the thread end of clutch switch and stopper rubber (2) to the specified value while clutch pedal is fully depressed.

Clearance "C" : Refer to [CL-21, "Clutch Pedal"](#).

3. Fasten clutch switch by turning it 45 degrees clockwise.

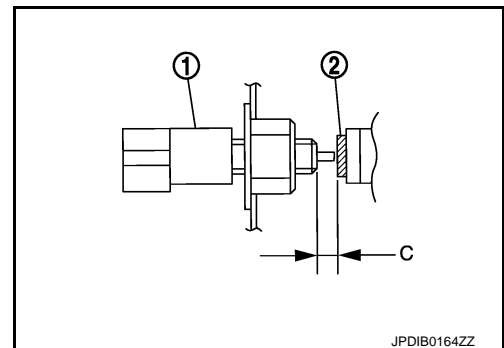

Position of ASCD Clutch Switch (With ASCD)

1. Loosen ASCD clutch switch by turning it 45 degrees counterclockwise.
2. Press the ASCD clutch switch (1) to bring clearance "A" between the thread end of ASCD clutch switch and clutch pedal (2) to the specified value while clutch pedal is fully released.

Clearance "A" : Refer to [CL-21, "Clutch Pedal"](#).

3. Fasten ASCD clutch switch by turning it 45 degrees clockwise.

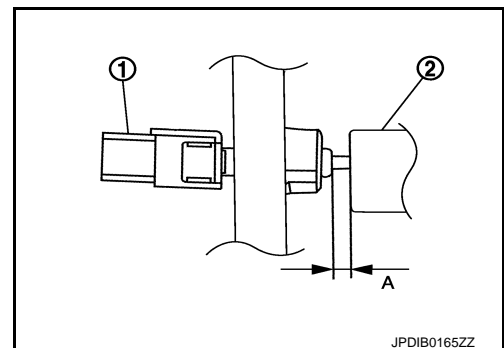

CLUTCH FLUID

< PERIODIC MAINTENANCE >

CLUTCH FLUID

Inspection

INFOID:000000004875832

FLUID LEVEL

- Check that the fluid level in the reservoir tank is within the specified range (MAX – MIN lines).
- Visually check for any clutch fluid leakage around the reservoir tank.
- Check the clutch system for any leakage if the fluid level is extremely low (lower than MIN).

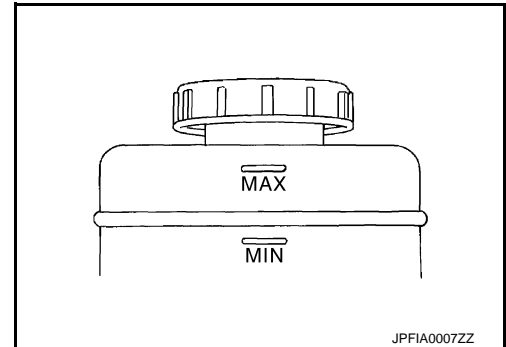

FLUID LEAKAGE

- Check clutch line for cracks, deterioration or other damage. Replace any damaged parts.
- Check for fluid leakage by fully depressing clutch pedal while engine is running.

CAUTION:

If leakage occurs around joints, reinstall the joints or, if necessary, replace damaged parts.

Draining

INFOID:000000004876020

CAUTION:

Keep painted surface on the body or other parts free of clutch fluid. If it spills, wipe up immediately and wash the affected area with water.

1. Connect a transparent vinyl hose to air bleeder of bleeding connector (1).

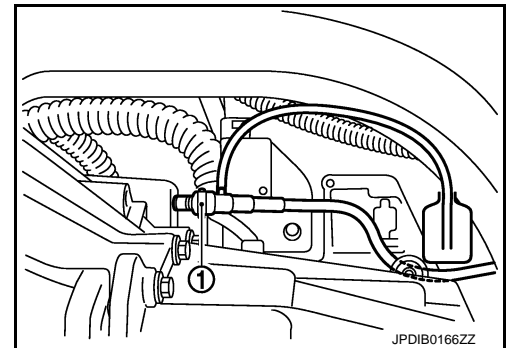

2. Press the lock pin (1) into the bleeding connector (2), and maintain the position.

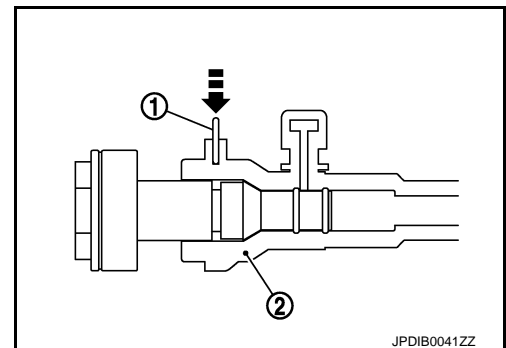

CLUTCH FLUID

< PERIODIC MAINTENANCE >

- Slide bleeding connector (1) in the direction of the arrow as shown in the figure.

2 : Clutch housing

Dimension "A" : 10 mm (0.39 in)

- Depress clutch pedal to gradually discharge clutch fluid.

CAUTION:

Since the inside of clutch tube is under hydraulic pressure, hold the tube to prevent it from getting disconnected.

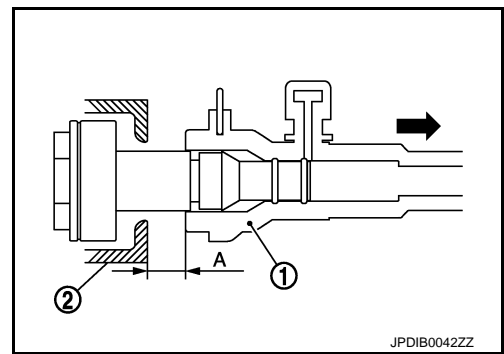

INFOID:000000004876022

Refilling

CAUTION:

Keep painted surface on the body or other parts free of clutch fluid. If it spills, wipe up immediately and wash the affected area with water.

- Check that there is no foreign material in reservoir tank and then fill with new clutch fluid.

CAUTION:

Never reuse drained clutch fluid.

- Connect a transparent vinyl hose to air bleeder of bleeding connector (1).

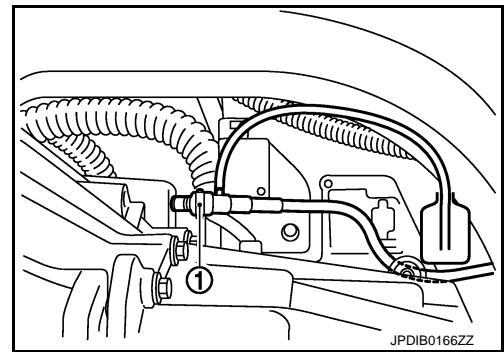

- Press the lock pin (1) into the bleeding connector (2), and maintain the position.

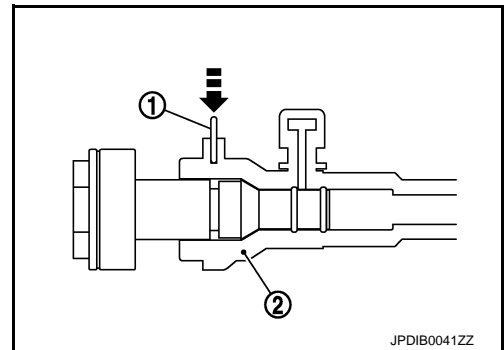

- Slide bleeding connector (1) in the direction of the arrow as shown in the figure.

2 : Clutch housing

Dimension "A" : 10 mm (0.39 in)

- Slowly depress clutch pedal to the full stroke position and then release the pedal.

CAUTION:

Since the inside of clutch tube is under hydraulic pressure, hold the tube to prevent it from getting disconnected.

- Repeat step 5 at intervals of 2 or 3 seconds until new clutch fluid is discharged.

CAUTION:

Monitor clutch fluid level in reservoir tank so as not to empty the tank.

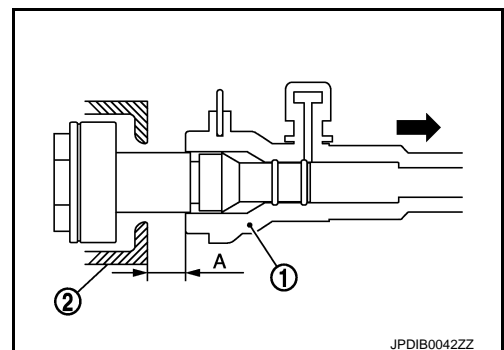

CLUTCH FLUID

< PERIODIC MAINTENANCE >

- Return clutch tube and lock pin in their original positions while clutch pedal is depressed.
- Perform the air bleeding. Refer to [CL-10, "Air Bleeding Procedure"](#).

Air Bleeding Procedure

INFOID:000000004875833

CAUTION:

- Monitor clutch fluid level in reservoir tank so as not to empty the tank.
- Keep painted surface on the body or other parts free of clutch fluid. If it spills, wipe up immediately and wash the affected area with water.

NOTE:

Do not use a vacuum assist or any other type of power bleeder on this system. Use of a vacuum assist or power bleeder will not purge all the air from the system.

- Bleed the air of bleeding connector (1).

- Fill reservoir tank with new clutch fluid.

CAUTION:

Never reuse drained clutch fluid.

- Connect a transparent vinyl hose to air bleeder of bleeding connector.
- "Depress" and "release" the clutch pedal slowly and fully 15 times at an interval of 2 to 3 seconds and release the clutch pedal.

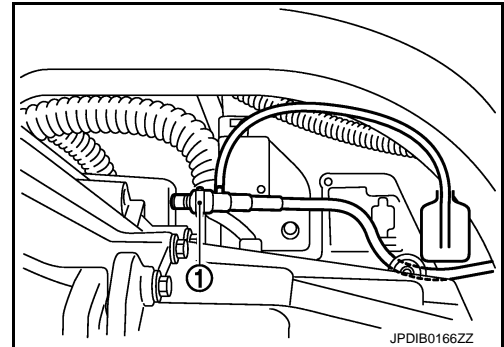

- Press the lock pin (1) into the bleeding connector (2), and maintain the position.

CAUTION:

Since the inside of clutch tube is under hydraulic pressure, hold the tube to prevent it from getting disconnected.

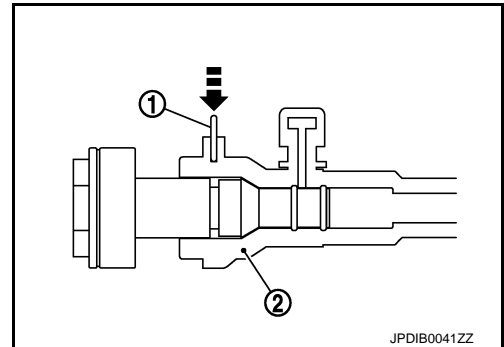

- Slide bleeding connector (1) in the direction of the arrow as shown in the figure.

2 : Clutch housing

Dimension "A" : 10 mm (0.39 in)

- Depress the clutch pedal soon and hold it, and then bleed the air from the piping.

CAUTION:

Since the inside of clutch tube is under hydraulic pressure, hold the tube to prevent it from getting disconnected.

- Return clutch tube and lock pin in their original positions.
- Release clutch pedal and wait for 5 seconds.
- Repeat steps 3 to 8 until no bubbles are observed in the clutch fluid.
- Check that the fluid level in the reservoir tank is within the specified range after air bleeding. Refer to [CL-8, "Inspection"](#).

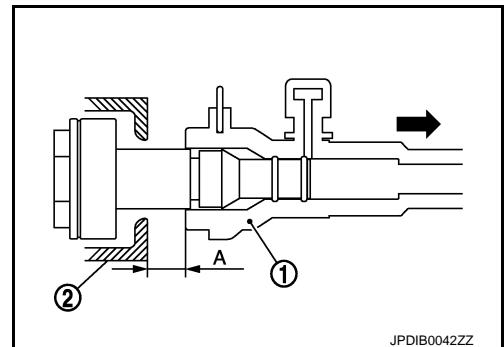

CLUTCH PEDAL

< REMOVAL AND INSTALLATION >

REMOVAL AND INSTALLATION

CLUTCH PEDAL

Exploded View

INFOID:000000004875834

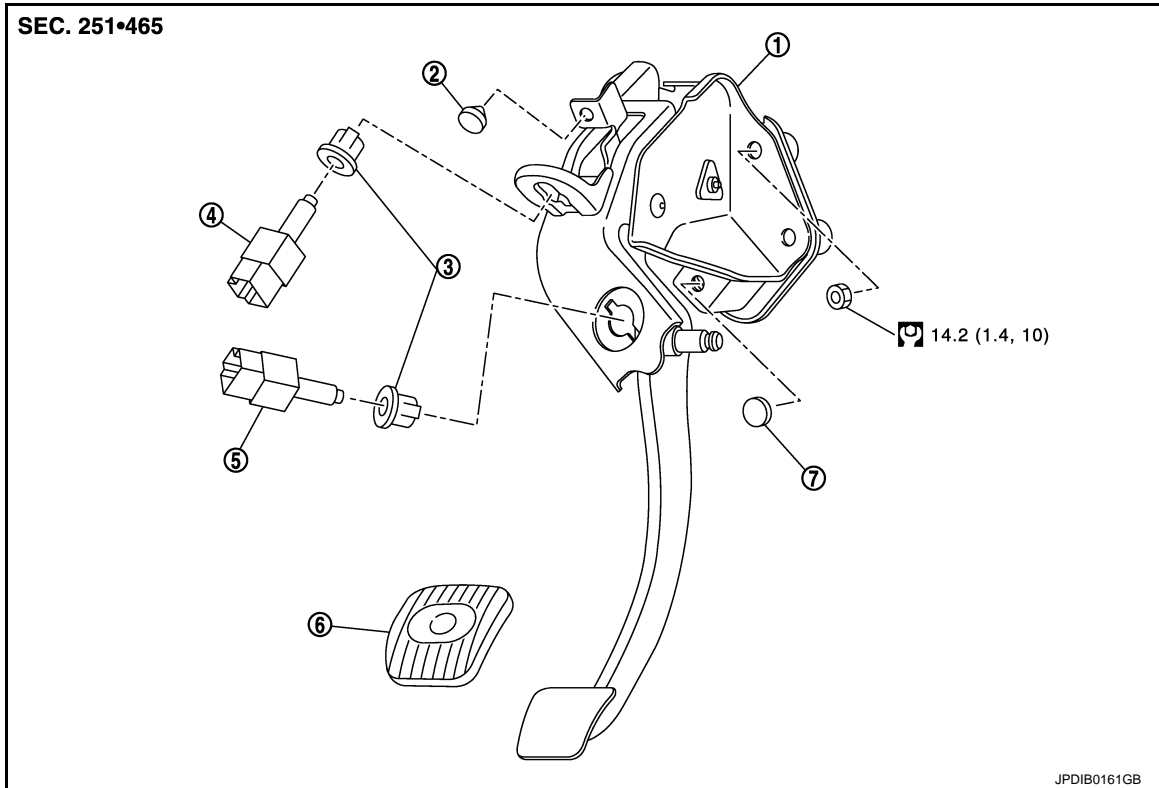

- | | | |
|-------------------------|-----------------------------------|--------------|
| 1. Clutch pedal | 2. Stopper rubber | 3. Clip |
| 4. Clutch switch | 5. ASCD clutch switch (With ASCD) | 6. Pedal pad |
| 7. Pedal stopper rubber | | |

Refer to [GI-4, "Components"](#) for the symbols in the figure.

Removal and Installation

INFOID:000000004875835

REMOVAL

1. Disconnect ASCD clutch switch connector. (With ASCD)
2. Disconnect clutch switch connector.
3. Disconnect clip of harness from clutch pedal.
4. Remove master cylinder rod end from clutch pedal.
5. Remove ASCD clutch switch and clip from clutch pedal. (With ASCD)
6. Remove clutch switch, clip, and pedal pad from clutch pedal.
7. Remove stopper rubber and pedal stopper rubber from clutch pedal, using a suitable remover.
8. Remove clutch pedal from the vehicle.

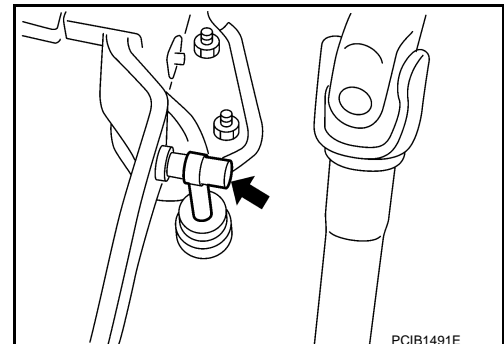

INSTALLATION

Note the following, and install in the reverse order of removal.

CLUTCH PEDAL

< REMOVAL AND INSTALLATION >

CAUTION:

Press master cylinder rod end into clutch pedal until it stops.

Inspection and Adjustment

INFOID:000000004875836

INSPECTION AFTER REMOVAL

- Check clutch pedal for bend, damage, or a cracked weld. If bend, damage, or a cracked weld is found, replace clutch pedal.
- Check stopper rubber and pedal stopper rubber. If damage or deformation is found, replace stopper rubber and pedal stopper rubber.
- Check pedal pad. If wear or damage is found, replace pedal pad.

INSPECTION AFTER INSTALLATION

- Check the clutch pedal and clutch switch position. Refer to [CL-6, "Inspection and Adjustment"](#).
- Check the ASCD clutch switch position. (With ASCD) Refer to [CL-6, "Inspection and Adjustment"](#).

ADJUSTMENT AFTER INSTALLATION

- Adjust the clutch switch position. Refer to [CL-6, "Inspection and Adjustment"](#).
- Adjust the ASCD clutch switch position. (With ASCD) Refer to [CL-6, "Inspection and Adjustment"](#).

CLUTCH MASTER CYLINDER

< REMOVAL AND INSTALLATION >

CLUTCH MASTER CYLINDER

Exploded View

INFOID:000000004875837

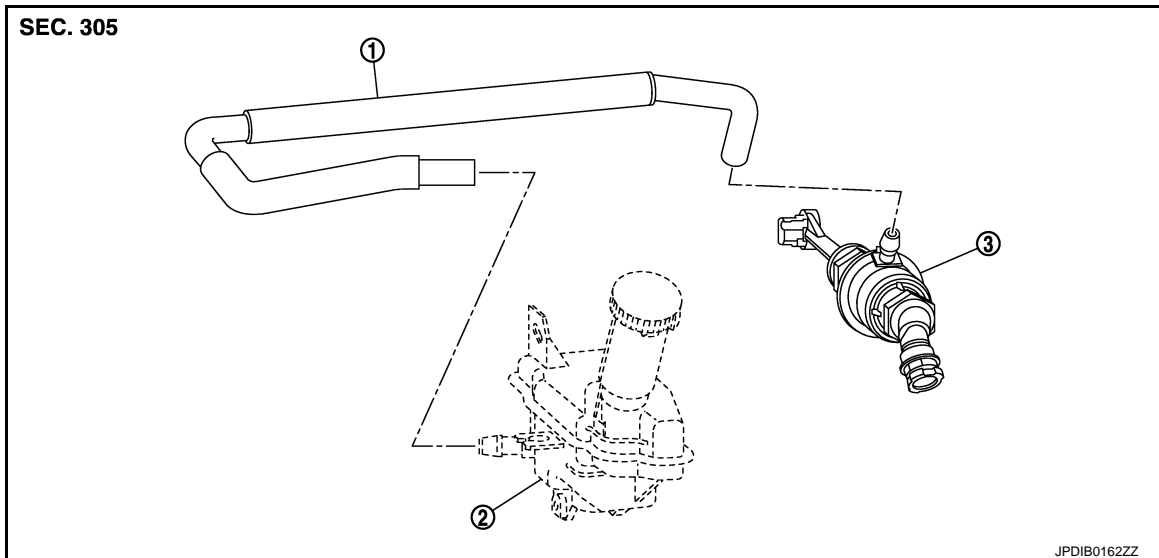

1. Hose
2. Reservoir tank assembly
3. Master cylinder

Removal and Installation

INFOID:000000004875838

REMOVAL

CAUTION:

- Keep painted surface on the body or other parts free of clutch fluid. If it spills, wipe up immediately and wash the affected area with water.

- Never disassemble master cylinder.

1. Drain clutch fluid. Refer to [CL-8, "Draining"](#).
2. Remove air duct (inlet). Refer to [EM-24, "Removal and Installation"](#).
3. Remove battery. Refer to [PG-95, "Removal and Installation"](#).
4. Remove air cleaner case and air ducts. Refer to [EM-24, "Removal and Installation"](#).
5. Remove hose from reservoir tank assembly and master cylinder.
6. Remove master cylinder rod end (←) from clutch pedal.

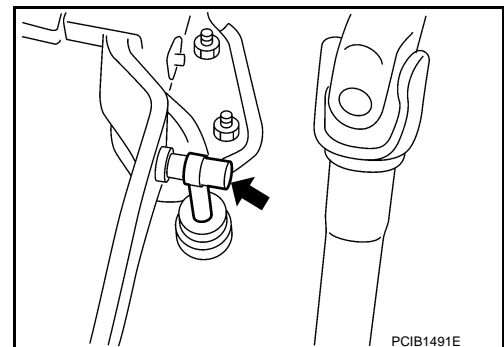

CLUTCH MASTER CYLINDER

< REMOVAL AND INSTALLATION >

7. Remove lock pin (1) from connector of master cylinder (2) and separate clutch tube (3).
8. Rotate master cylinder clockwise by 45 degrees and then remove master cylinder from the vehicle.

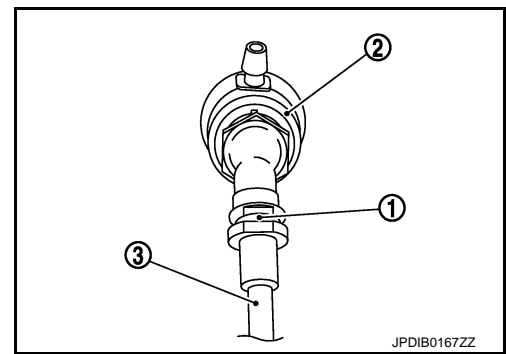

INSTALLATION

CAUTION:

Keep painted surface on the body or other parts free of clutch fluid. If it spills, wipe up immediately and wash the affected area with water.

1. Tilt master cylinder clockwise by 45 degrees (A) and insert it to the mounting hole. Rotate counterclockwise and secure it. At this time, nipple (1) is upward of the vehicle.

B : Mounting condition

2. Install master cylinder rod end to clutch pedal.

CAUTION:

Press master cylinder rod end into clutch pedal until it stops.

3. Install hose to reservoir tank assembly and master cylinder.

CAUTION:

Set hose with painted mark facing upward.

4. Install lock pin into connector of master cylinder until it stops.
5. Install clutch tube into connector of master cylinder until it stops.
6. Install air cleaner case and air ducts. Refer to [EM-24, "Removal and Installation"](#).
7. Install battery. Refer to [PG-95, "Removal and Installation"](#).
8. Install air duct (inlet). Refer to [EM-24, "Removal and Installation"](#).
9. Fill with clutch fluid. Refer to [CL-9, "Refilling"](#).

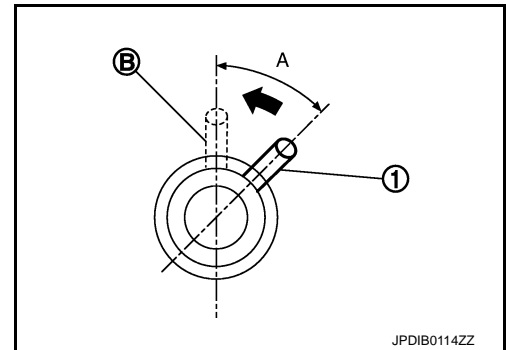

Inspection and Adjustment

INFOID:000000004876117

INSPECTION AFTER INSTALLATION

- Check the clutch fluid level and clutch fluid leakage. Refer to [CL-8, "Inspection"](#).
- Check the clutch pedal and clutch switch position. Refer to [CL-6, "Inspection and Adjustment"](#).
- Check the ASCD clutch switch position. (With ASCD) Refer to [CL-6, "Inspection and Adjustment"](#).

ADJUSTMENT AFTER INSTALLATION

- Adjust the clutch switch position. Refer to [CL-6, "Inspection and Adjustment"](#).
- Adjust the ASCD clutch switch position. (With ASCD) Refer to [CL-6, "Inspection and Adjustment"](#).
- Bleed air from the clutch hydraulic system. Refer to [CL-10, "Air Bleeding Procedure"](#).

CLUTCH PIPING

< REMOVAL AND INSTALLATION >

CLUTCH PIPING

Exploded View

INFOID:000000004875839

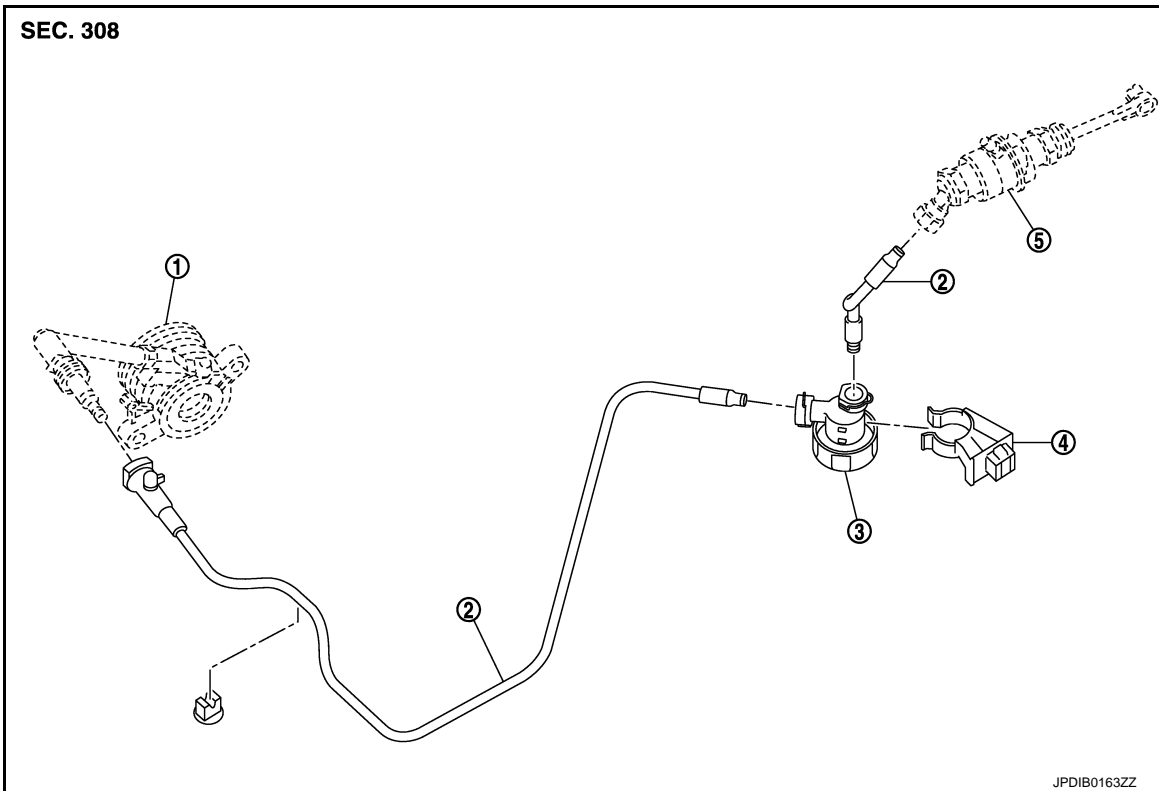

- | | | |
|------------------------------------|--------------------|------------------|
| 1. CSC (Concentric Slave Cylinder) | 2. Clutch tube | 3. Clutch damper |
| 4. Bracket | 5. Master cylinder | |

Hydraulic Layout

INFOID:000000004875840

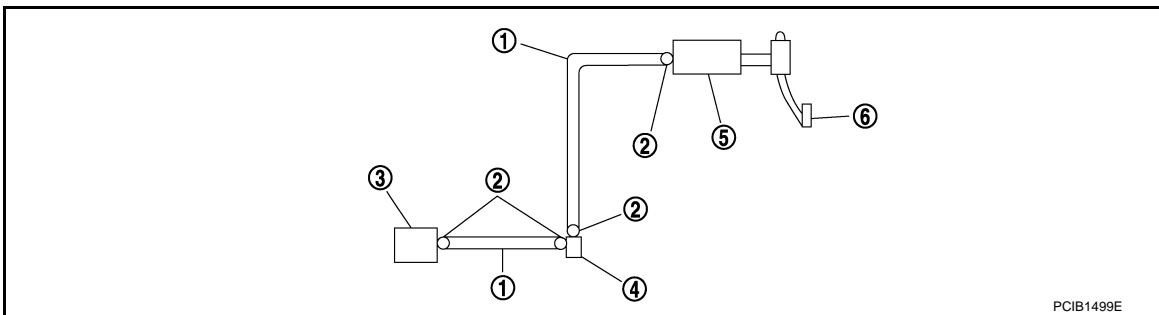

- | | | |
|------------------|--------------------|------------------------------------|
| 1. Clutch tube | 2. Lock pin | 3. CSC (Concentric Slave Cylinder) |
| 4. Clutch damper | 5. Master cylinder | 6. Clutch pedal |

Removal and Installation

INFOID:000000004875841

CAUTION:

Keep painted surface on the body or other parts free of clutch fluid. If it spills, wipe up immediately and wash the affected area with water.

REMOVAL

Note the following, and refer to [CL-15, "Exploded View"](#) for removal procedure.

- Drain clutch fluid. Refer to [CL-8, "Draining"](#).

CLUTCH PIPING

< REMOVAL AND INSTALLATION >

- Press the lock pin into the bleeding connector of the clutch tube and then remove clutch tube from CSC.
- Pull the lock pins from the connectors of the clutch damper until the pins stop and then remove clutch tubes from clutch damper.
- Pull the lock pin from the connector of the clutch master cylinder until the pin stop and then remove clutch tube from clutch master cylinder.

INSTALLATION

Note the following, and refer to [CL-15, "Exploded View"](#) for installation procedure.

CAUTION:

Never damage clutch tube.

- Check O-ring of clutch tube for cracks or damage. Replace it if cracked or damaged.
- Insert clutch tubes until they contact CSC connector, clutch damper connector, and clutch master cylinder connector.
- Install lock pins into bleeding connector of clutch tube, clutch damper connector, and clutch master cylinder connector until lock pins contact the connectors.
- Fill with clutch fluid. Refer to [CL-9, "Refilling"](#).

Inspection and Adjustment

INFOID:000000004876118

INSPECTION AFTER INSTALLATION

Check the clutch fluid level and clutch fluid leakage. Refer to [CL-8, "Inspection"](#).

ADJUSTMENT AFTER INSTALLATION

Bleed air from the clutch hydraulic system. Refer to [CL-10, "Air Bleeding Procedure"](#).

CSC (CONCENTRIC SLAVE CYLINDER)

< UNIT REMOVAL AND INSTALLATION >

UNIT REMOVAL AND INSTALLATION

CSC (CONCENTRIC SLAVE CYLINDER)

Exploded View

INFOID:000000004875851

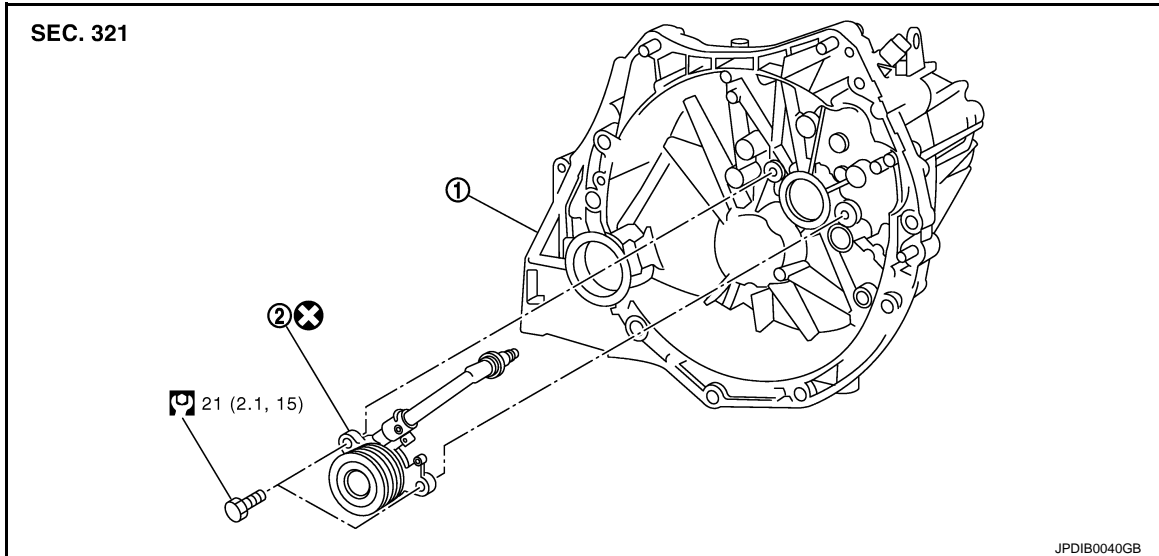

1. Transaxle assembly
2. CSC (Concentric Slave Cylinder)

Refer to [GI-4, "Components"](#) for the symbols in the figure.

Removal and Installation

INFOID:000000004875852

CAUTION:

- **Never reuse CSC (Concentric Slave Cylinder).** Because CSC slides back to the original position every time when removing transaxle assembly. At this timing, dust on the sliding parts may damage a seal of CSC and may cause clutch fluid leakage.
- **Never disassemble CSC.**
- **Keep painted surface on the body or other parts free of clutch fluid.** If it spills, wipe up immediately and wash the affected area with water.

REMOVAL

1. Remove transaxle assembly from the engine. Refer to [TM-24, "Removal and Installation"](#).
2. Remove CSC mounting bolts and then remove CSC from clutch housing.

INSTALLATION

1. Install CSC to clutch housing and then tighten CSC mounting bolts to the specified torque.

CAUTION:

- **Never reuse CSC.**
 - **Never insert and operate CSC because piston and stopper of CSC components may fall off.**
2. Install transaxle assembly to the engine. Refer to [TM-24, "Removal and Installation"](#).

Inspection and Adjustment

INFOID:000000004876119

INSPECTION AFTER INSTALLATION

Check the clutch fluid level and clutch fluid leakage. Refer to [CL-8, "Inspection"](#).

ADJUSTMENT AFTER INSTALLATION

Bleed air from the clutch hydraulic system. Refer to [CL-10, "Air Bleeding Procedure"](#).

CLUTCH DISC AND CLUTCH COVER

< UNIT REMOVAL AND INSTALLATION >

CLUTCH DISC AND CLUTCH COVER

Exploded View

INFOID:000000004876122

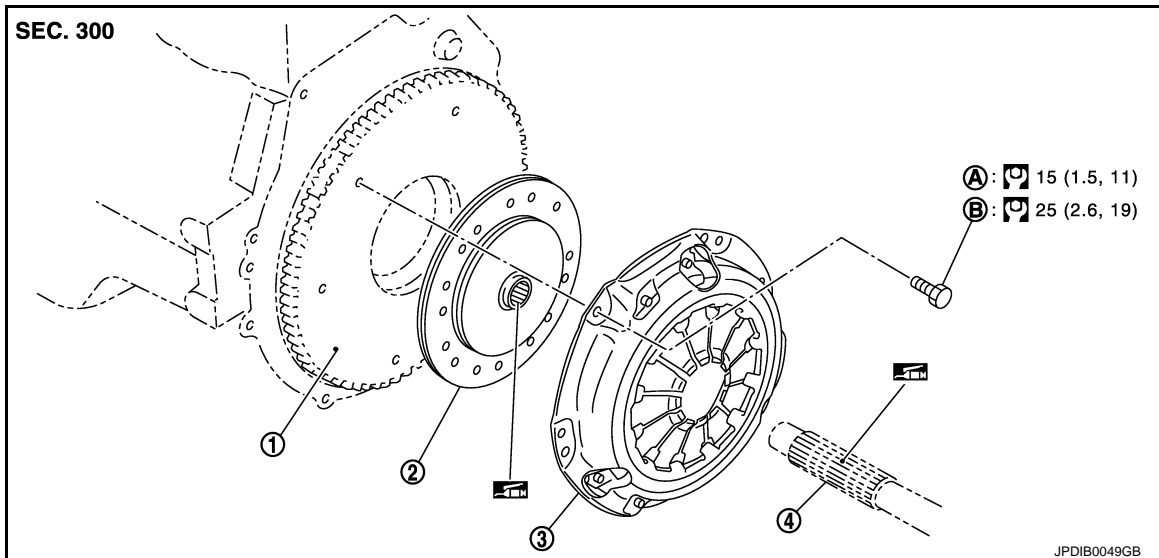

- | | | |
|----------------|----------------|-----------------|
| 1. Flywheel | 2. Clutch disc | 3. Clutch cover |
| 4. Input shaft | | |
| A. First step | B. Final step | |

: Apply lithium-based grease including molybdenum disulphide.

Refer to [GI-4, "Components"](#) for symbols not described on the above.

Removal and Installation

INFOID:000000004876123

CAUTION:

- Never reuse CSC (Concentric Slave Cylinder). Because CSC slides back to the original position every time when removing transaxle assembly. At this timing, dust on the sliding parts may damage a seal of CSC and may cause clutch fluid leakage. Refer to [CL-17, "Removal and Installation"](#).
- Never bring any grease to the clutch disc facing, pressure plate surface and flywheel surface.
- When installing, be careful that grease applied to input shaft does not adhere to clutch disc.
- Never clean clutch disc using solvent.

REMOVAL

1. Remove transaxle assembly from the engine. Refer to [TM-24, "Removal and Installation"](#).
2. Remove clutch cover mounting bolts, using a power tool [Commercial service tool].
3. Remove clutch cover and clutch disc.

CAUTION:

Never drop clutch disc.

INSTALLATION

1. Clean clutch disc and input shaft splines to remove grease and powder arisen from abrasion.
2. Apply recommended grease to clutch disc and input shaft splines.

CAUTION:

Be sure to apply grease to the points specified. Otherwise, noise, poor disengagement, or damage to the clutch may result. Excessive grease may cause slip or judder. And if it adheres to seal of CSC, it cause clutch fluid leakage. wipe out excess grease. wipe out any grease oozing from the parts.

CLUTCH DISC AND CLUTCH COVER

< UNIT REMOVAL AND INSTALLATION >

3. Install clutch disc, using a clutch aligner (A) [Commercial service tool].
4. Install clutch cover and then temporarily tighten clutch cover mounting bolts.
5. Tighten clutch cover mounting bolts to the specified torque evenly in two steps in the numerical order as shown in the figure.
6. Install transaxle assembly to the engine. Refer to [TM-24, "Removal and Installation"](#).

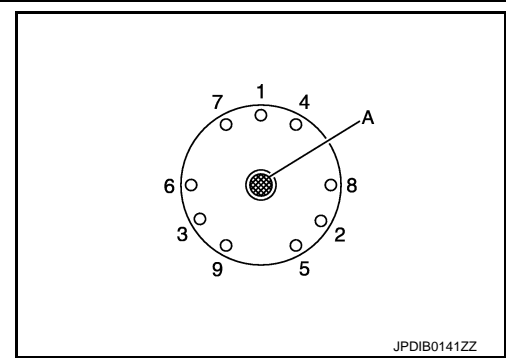

Inspection

INSPECTION AFTER REMOVAL

CLUTCH DISC

- Measure circumferential runout relative to clutch disc center spline. If it is outside the specification, replace clutch disc.

Runout limit/diameter of the area to be measured : Refer to [CL-21, "Clutch Disc"](#).

- Measure backlash to clutch disc spline and main drive gear spline at the circumference of clutch disc. If it is outside the specification, replace clutch disc.

Maximum allowable spline backlash (at outer edge of disc) : Refer to [CL-21, "Clutch Disc"](#).

- Measure the depth "A" to clutch disc facing rivet heads, using a calipers. If it exceeds the allowable wear limit, replace clutch disc.

Facing wear limit (depth to the rivet head) "A" : Refer to [CL-21, "Clutch Disc"](#).

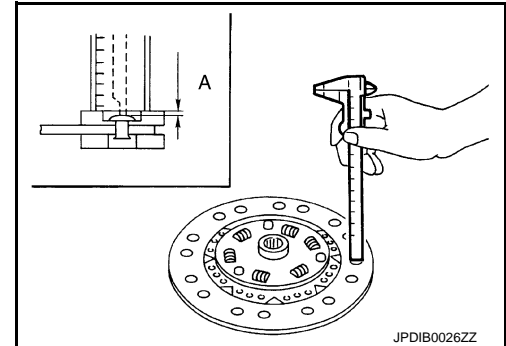
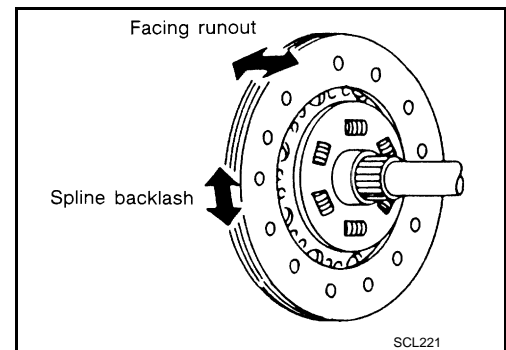

CLUTCH COVER

- Check clutch cover thrust ring for wear or breakage. If wear or breakage is found, replace clutch cover.

NOTE:

- Worn thrust ring will generate a beating noise when tapped at the rivet with a hammer.
- Broken thrust ring will make a clinking sound when cover is shaken up and down.
- If a trace of burn or discoloration is found on the clutch cover pressure plate to clutch disc contact surface, repair the surface with sandpaper. If surface is damaged or distorted, replace clutch cover.

INSPECTION AFTER INSTALLATION

CLUTCH COVER

A
B
C
CL

E
F
G
H
I
J
K
L

M
N
O
P

CLUTCH DISC AND CLUTCH COVER

< UNIT REMOVAL AND INSTALLATION >

Check diaphragm spring lever claws for unevenness with the lever still on the vehicle. If they exceed the tolerance, adjust lever height, using the diaphragm adjusting wrench (A) [SST: ST20050240 (-)].

Tolerance for diaphragm spring lever unevenness : Refer to [CL-21, "Clutch Cover"](#).

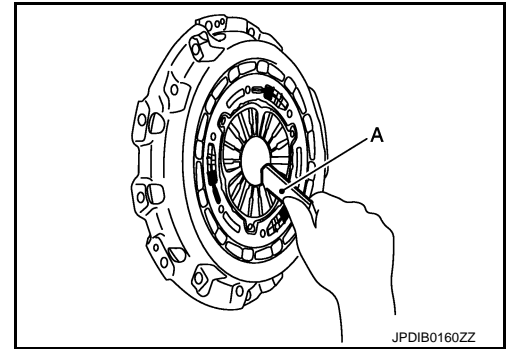

SERVICE DATA AND SPECIFICATIONS (SDS)

< SERVICE DATA AND SPECIFICATIONS (SDS)

SERVICE DATA AND SPECIFICATIONS (SDS)

SERVICE DATA AND SPECIFICATIONS (SDS)

Clutch Control System

INFOID:0000000004875921

Type of clutch control	Hydraulic
------------------------	-----------

Clutch Pedal

INFOID:0000000004875922

Clutch pedal height "H1"	173.6 – 183.6 mm (6.83 – 7.23 in)
Clutch pedal height at clutch disengagement "H2"	80 mm (3.15 in) or more
Clutch pedal play "A" [Looseness at clutch pedal pin]	2 – 8 mm (0.08 – 0.31 in) [0 – 1.3 mm (0 – 0.051 in)]
Clearance "C" between stopper rubber and clutch switch threaded end while clutch pedal is fully depressed.	0.74 – 1.96 mm (0.0291 – 0.0772 in)
Clearance "A" between clutch pedal and ASCD clutch switch threaded end while clutch pedal is fully released. (With ASCD)	0.74 – 1.96 mm (0.0291 – 0.0772 in)

Clutch Disc

INFOID:0000000004875923

Facing size (outer dia. × inner dia. × thickness)	225 mm × 160 mm × 3.2 mm (8.86 in × 6.30 in × 0.126 in)
Runout limit/diameter of the area to be measured	1.0 mm (0.039 in) / 215 mm (8.46 in) dia.
Maximum allowable spline backlash (at outer edge of disc)	0.9 mm (0.035 in)
Facing wear limit (depth to the rivet head) "A"	0.3 mm (0.012 in)

Clutch Cover

INFOID:0000000004875924

Tolerance for diaphragm spring lever unevenness	0.7 mm (0.028 in) or less
---	---------------------------