

SECTION **PWO**
POWER OUTLET

A
B
C
D
E
F
G
H
I
J
K
L
N
O
P

CONTENTS

DTC/CIRCUIT DIAGNOSIS	2	Precaution for Supplemental Restraint System (SRS) "AIR BAG" and "SEAT BELT PRE-TENSIONER"	4
POWER SOCKET	2		
Wiring Diagram - POWER SOCKET -	2		
PRECAUTION	4	REMOVAL AND INSTALLATION	5
PRECAUTIONS	4	POWER SOCKET	5
		Exploded View	5
		Removal and Installation	5

PWO

POWER SOCKET

< DTC/CIRCUIT DIAGNOSIS >

DTC/CIRCUIT DIAGNOSIS

POWER SOCKET

Wiring Diagram - POWER SOCKET -

INFOID:000000005491423

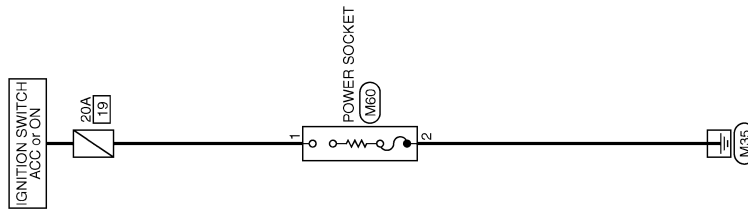

POWER SOCKET

2009/10/02

JCMWM5303G



POWER SOCKET

< DTC/CIRCUIT DIAGNOSIS >

A
B
C
D
E
F
G
H
I
J
K
L
N
O
P

POWER SOCKET

Connector No.	M6D
Connector Name	POWER SOCKET
Connector Type	PO2PE-Z

Terminal No.	Color of Wire	Signal Name [Specification]
1	V	-
2	B	-

PWO

JCMWM5304G1

PRECAUTIONS

< PRECAUTION >

PRECAUTION

PRECAUTIONS

Precaution for Supplemental Restraint System (SRS) "AIR BAG" and "SEAT BELT PRE-TENSIONER"

INFOID:000000005491424

The Supplemental Restraint System such as "AIR BAG" and "SEAT BELT PRE-TENSIONER", used along with a front seat belt, helps to reduce the risk or severity of injury to the driver and front passenger for certain types of collision. This system includes seat belt switch inputs and dual stage front air bag modules. The SRS system uses the seat belt switches to determine the front air bag deployment, and may only deploy one front air bag, depending on the severity of a collision and whether the front occupants are belted or unbelted. Information necessary to service the system safely is included in the "SRS AIR BAG" and "SEAT BELT" of this Service Manual.

WARNING:

- To avoid rendering the SRS inoperative, which could increase the risk of personal injury or death in the event of a collision which would result in air bag inflation, all maintenance must be performed by an authorized NISSAN/INFINITI dealer.
- Improper maintenance, including incorrect removal and installation of the SRS, can lead to personal injury caused by unintentional activation of the system. For removal of Spiral Cable and Air Bag Module, see the "SRS AIR BAG".
- Do not use electrical test equipment on any circuit related to the SRS unless instructed to in this Service Manual. SRS wiring harnesses can be identified by yellow and/or orange harnesses or harness connectors.

PRECAUTIONS WHEN USING POWER TOOLS (AIR OR ELECTRIC) AND HAMMERS

WARNING:

- When working near the Air Bag Diagnosis Sensor Unit or other Air Bag System sensors with the ignition ON or engine running, DO NOT use air or electric power tools or strike near the sensor(s) with a hammer. Heavy vibration could activate the sensor(s) and deploy the air bag(s), possibly causing serious injury.
- When using air or electric power tools or hammers, always switch the ignition OFF, disconnect the battery, and wait at least 3 minutes before performing any service.

POWER SOCKET

< REMOVAL AND INSTALLATION >

REMOVAL AND INSTALLATION

POWER SOCKET

Exploded View

- 1 : Inner socket
- 2 : Ring

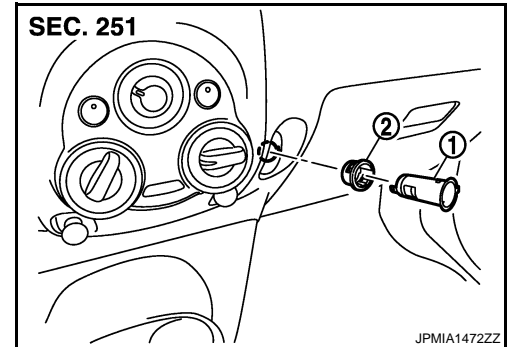

Removal and Installation

REMOVAL

1. Remove glove box assembly. Refer to [IP-12, "Exploded View"](#).
2. Disconnect power socket connector (A).

B : Cut out

3. Pull out inner socket (1) by pushing the ring pawl (C) from the inner socket hole (square) (D).
4. Remove ring (2) from instrument panel while pressing pawls.

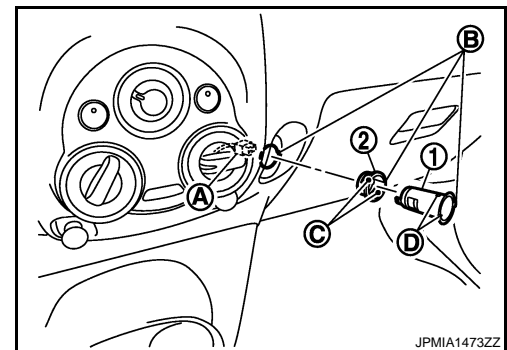

INSTALLATION

Install in the reverse order of removal.

NOTE:

Align the cut outs of inner socket, ring, and instrument panel.

A
B
C
D
E
F
G
H
I
J
K
L
N
O
P

PWO