

**SECTION MA**  
**MAINTENANCE**

A  
B  
C  
D  
E  
F  
G  
H  
I  
J  
K  
L  
M  
N  
O

**CONTENTS**

<b>PREPARATION</b> .....	<b>ENGINE OIL : Refilling</b> .....	3	16
<b>PREPARATION</b> .....	<b>OIL FILTER</b> .....	3	17
Special Service Tool .....	OIL FILTER : Removal and Installation .....	3	17
Commercial Service Tool .....	OIL FILTER : Inspection .....	3	17
<b>PERIODIC MAINTENANCE</b> .....	<b>SPARK PLUG</b> .....	4	17
<b>GENERAL MAINTENANCE</b> .....	SPARK PLUG : Removal and Installation .....	4	18
Explanation of General Maintenance .....	SPARK PLUG : Inspection .....	4	18
<b>PERIODIC MAINTENANCE</b> .....	<b>EVAP VAPOR LINES</b> .....	6	18
Introduction of Periodic Maintenance .....	EVAP VAPOR LINES : Inspection .....	6	18
Schedule 1 .....	<b>CHASSIS MAINTENANCE</b> .....	6	19
Schedule 2 .....	<b>EXHAUST SYSTEM</b> .....	8	19
<b>RECOMMENDED FLUIDS AND LUBRICANTS</b> .....	EXHAUST SYSTEM : Inspection .....	10	19
Fluids and Lubricants .....	<b>CVT FLUID</b> .....	10	19
Engine Oil Recommendation .....	CVT FLUID : Inspection .....	10	19
Anti-Freeze Coolant Mixture Ratio .....	CVT FLUID : Changing .....	11	20
<b>ENGINE MAINTENANCE</b> .....	<b>GEAR OIL</b> .....	12	20
<b>DRIVE BELT</b> .....	GEAR OIL : Inspection .....	12	21
DRIVE BELT : Exploded View .....	GEAR OIL : Draining .....	12	21
DRIVE BELT : Checking .....	GEAR OIL : Refilling .....	12	21
DRIVE BELT : Tension Adjustment .....	<b>CLUTCH FLUID</b> .....	12	21
<b>ENGINE COOLANT</b> .....	CLUTCH FLUID : Inspection .....	12	21
ENGINE COOLANT : Draining .....	<b>WHEELS (BONDING WEIGHT TYPE)</b> .....	12	22
ENGINE COOLANT : Refilling .....	WHEELS (BONDING WEIGHT TYPE) : Adjust- ment .....	13	22
ENGINE COOLANT : Flushing .....	<b>BRAKE FLUID LEVEL AND LEAKS</b> .....	14	23
<b>FUEL LINES</b> .....	BRAKE FLUID LEVEL AND LEAKS : Inspection .....	15	24
FUEL LINES : Inspection .....	<b>BRAKE LINES AND CABLES</b> .....	15	24
<b>AIR CLEANER FILTER</b> .....	BRAKE LINES AND CABLES : Inspection .....	15	24
AIR CLEANER FILTER : Removal and Installation .....	<b>BRAKE FLUID</b> .....	15	24
.....	BRAKE FLUID : Changing .....	16	24
<b>ENGINE OIL</b> .....	<b>DISC BRAKE</b> .....	16	24
ENGINE OIL : Draining .....	DISC BRAKE : Inspection .....	16	24

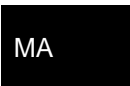

DISC BRAKE : Front Disc Brake .....	25
<b>DRUM BRAKE .....</b>	<b>25</b>
DRUM BRAKE : Inspection .....	25
DRUM BRAKE : Rear Drum Brake .....	26
<b>STEERING GEAR AND LINKAGE .....</b>	<b>26</b>
STEERING GEAR AND LINKAGE : Inspection ....	26
<b>AXLE AND SUSPENSION PARTS .....</b>	<b>26</b>
AXLE AND SUSPENSION PARTS : Inspection ....	26
<b>DRIVE SHAFT .....</b>	<b>27</b>
DRIVE SHAFT : Inspection .....	27
<b>BODY MAINTENANCE .....</b>	<b>28</b>
<b>LOCKS, HINGES AND HOOD LATCH .....</b>	<b>28</b>
LOCKS, HINGES AND HOOD LATCH : Lubricat- ing .....	28
<b>SEAT BELT, BUCKLES, RETRACTORS, AN- CHORS AND ADJUSTERS .....</b>	<b>28</b>
SEAT BELT, BUCKLES, RETRACTORS, AN- CHORS AND ADJUSTERS : Inspection .....	28

<b>SERVICE DATA AND SPECIFICATIONS (SDS) .....</b>	<b>29</b>
<b>SERVICE DATA AND SPECIFICATIONS (SDS) .....</b>	<b>29</b>
<b>DRIVE BELT .....</b>	<b>29</b>
DRIVE BELT : Drive Belt .....	29
<b>ENGINE COOLANT .....</b>	<b>29</b>
ENGINE COOLANT : Periodical Maintenance Specification .....	29
<b>ENGINE OIL .....</b>	<b>29</b>
ENGINE OIL : Periodical Maintenance Specifica- tion .....	29
<b>SPARK PLUG .....</b>	<b>29</b>
SPARK PLUG : Spark Plug .....	29
<b>ROAD WHEEL .....</b>	<b>29</b>
ROAD WHEEL : Road Wheel .....	29

# PREPARATION

< PREPARATION >

## PREPARATION

### PREPARATION

#### Special Service Tool

INFOID:000000006504562

The actual shapes of Kent-Moore tools may differ from those of special service tools illustrated here.

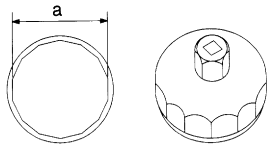
Tool number (Kent-Moore No.) Tool name	Description
KV10115801 (J-38956) Oil filter wrench  <p style="text-align: center;">S-NT375</p>	Removing and installing oil filter <b>a: 64.3 mm (2.531 in)</b>

#### Commercial Service Tool

INFOID:000000006504563

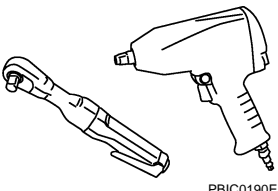
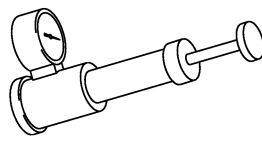
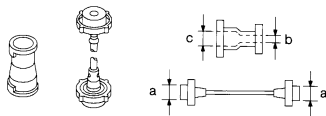
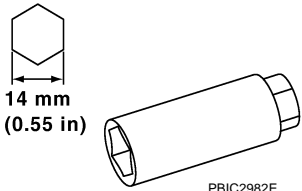
(Kent-Moore No.) Tool name	Description
( — ) Power tool  <p style="text-align: center;">PBIC0190E</p>	Loosening nuts and bolts
( — ) Radiator cap tester  <p style="text-align: center;">PBIC1982E</p>	Checking radiator and radiator cap
( — ) Radiator cap tester adapter  <p style="text-align: center;">S-NT564</p>	Adapting radiator cap tester to radiator cap and radiator filler neck <b>a: 28 (1.10) dia.</b> <b>b: 31.4 (1.236) dia.</b> <b>c: 41.3 (1.626) dia.</b> Unit: mm (in)
( — ) Spark plug wrench  <p style="text-align: center;">PBIC2982E</p>	Removing and installing spark plug

A  
B  
C  
D  
E  
F  
G  
H  
I  
J  
K  
L  
M  
N  
O

MA

# GENERAL MAINTENANCE

< PERIODIC MAINTENANCE >

## PERIODIC MAINTENANCE

### GENERAL MAINTENANCE

#### Explanation of General Maintenance

INFOID:000000006504564

General maintenance includes those items which should be checked during the normal day-to-day operation of the vehicle. They are essential if the vehicle is to continue operating properly. The owners can perform checks and inspections themselves or have their NISSAN dealers do them.

#### OUTSIDE THE VEHICLE

The maintenance items listed here should be performed from time to time, unless otherwise specified.

Item		Reference page
<b>Tires</b>	Check the pressure with a gauge often and always prior to long distance trips. Adjust the pressure in all tires, including the spare, to the pressure specified. Check carefully for damage, cuts or excessive wear.	<a href="#">WT-53</a>
<b>Wheel nuts</b>	When checking the tires, make sure no nuts are missing, and check for any loose nuts. Tighten if necessary.	—
<b>Tire rotation</b>	Tires should be rotated every 7,500 miles (12,000 km).	<a href="#">MA-22</a>
<b>Tire Pressure Monitoring System (TPMS) transmitter components</b>	Replace the TPMS transmitter grommet seal, valve core and cap when the tires are replaced due to wear or age.	<a href="#">WT-50</a>
<b>Wheel alignment and balance</b>	If the vehicle should pull to either side while driving on a straight and level road, or if you detect uneven or abnormal tire wear, there may be a need for wheel alignment. If the steering wheel or seat vibrates at normal highway speeds, wheel balancing may be needed. For additional information regarding tires, refer to "Important Tire Safety Information" (US) or "Tire Safety Information" (Canada) in the NISSAN Warranty Information Booklet.	<a href="#">FSU-6</a> , <a href="#">RSU-6</a> , <a href="#">MA-22</a>
<b>Windshield</b>	Clean the windshield on a regular basis. Check the windshield at least every six months for cracks or other damage. Repair as necessary.	—
<b>Windshield wiper blades</b>	Check for cracks or wear if they do not wipe properly.	—
<b>Doors and engine hood</b>	Check that all doors and the engine hood operate smoothly as well as the back door. Also make sure that all latches lock securely. Lubricate if necessary. Make sure that the secondary latch keeps the hood from opening when the primary latch is released. When driving in areas using road salt or other corrosive materials, check lubrication frequently.	<a href="#">MA-28</a>
<b>Lamps</b>	Make sure that the headlamps, stop lamps, tail lamps, turn signal lamps, and other lamps are all operating properly and installed securely. Also check headlamp aim. Clean the headlamps on a regular basis.	—

#### INSIDE THE VEHICLE

The maintenance items listed here should be checked on a regular basis, such as when performing periodic maintenance, cleaning the vehicle, etc.

Item		Reference page
<b>Warning lamps and chimes</b>	Make sure that all warning lamps and chimes are operating properly.	—
<b>Windshield wiper and washer</b>	Check that the wipers and washer operate properly and that the wipers do not streak.	—
<b>Windshield defroster</b>	Check that the air comes out of the defroster outlets properly and in sufficient quantity when operating the heater or air conditioner.	—
<b>Steering wheel</b>	Check that it has the specified play. Check for changes in the steering condition, such as excessive play, hard steering or strange noises. <b>Free play: Less than 35 mm (1.38 in)</b>	—
<b>Seats</b>	Check seat position controls such as seat adjusters, seatback recliner, etc. to make sure they operate smoothly and that all latches lock securely in every position. Check that the head restraints move up and down smoothly and that the locks (if equipped) hold securely in all latched positions. Check that the latches lock securely for folding-down rear seatbacks.	—

# GENERAL MAINTENANCE

## < PERIODIC MAINTENANCE >

Item		Reference page	
<b>Seat belts</b>	Check that all parts of the seat belt system (e.g. buckles, anchors, adjusters and retractors) operate properly and smoothly and are installed securely. Check the belt webbing for cuts, fraying, wear or damage.	<a href="#">MA-28</a>	A
<b>Accelerator pedal</b>	Check the pedal for smooth operation and make sure the pedal does not catch or require uneven effort. Keep the floor mats away from the pedal.	—	B
<b>Brakes</b>	Check that the brake does not pull the vehicle to one side when applied.	—	C
<b>Brake pedal and booster</b>	Check the pedal for smooth operation and make sure it has the proper distance under it when depressed fully. Check the brake booster function. Be sure to keep the floor mats away from the pedal.	<a href="#">BR-7</a> , <a href="#">BR-13</a>	D
<b>Clutch pedal</b>	Make sure the pedal operates smoothly and check that it has the proper free play.	<a href="#">CL-5</a>	E
<b>Parking brake</b>	Check that the lever or the pedal has the proper travel and make sure that the vehicle is held securely on a fairly steep hill when only the parking brake is applied.	<a href="#">PB-3</a>	
<b>CVT P (Park) position mechanism</b>	On a fairly steep hill check that the vehicle is held securely with the selector lever in the P (Park) position without applying any brakes.	—	

## UNDER THE HOOD AND VEHICLE

The maintenance items listed here should be checked periodically (e.g. each time you check the engine oil or refuel).

Item		Reference page	
<b>Windshield washer fluid</b>	Check that there is adequate fluid in the tank.	—	F
<b>Engine coolant level</b>	Check the coolant level when the engine is cold.	<a href="#">CO-9</a>	G
<b>Radiator and hoses</b>	Check the front of the radiator and clean off any dirt, insects, leaves, etc., that may have accumulated. Make sure the hoses have no cracks, deformation, deterioration or loose connections.	—	H
<b>Brake and clutch fluid levels</b>	Make sure that the brake and clutch fluid levels are between the "MAX" and "MIN" lines on the reservoir.	<a href="#">MA-24</a> , <a href="#">MA-21</a>	I
<b>Battery</b>	Check the fluid level in each cell. It should be between the "MAX" and "MIN" lines. Vehicles operated in high temperatures or under severe conditions require frequent checks of the battery fluid level.	<a href="#">PG-3</a>	J
<b>Engine drive belt</b>	Make sure that no belt is frayed, worn, cracked or oily.	<a href="#">MA-12</a>	K
<b>Engine oil level</b>	Check the level on the oil level gauge after parking the vehicle on a level spot and turning off the engine.	<a href="#">LU-7</a>	L
<b>Exhaust system</b>	Make sure there are no loose supports, cracks or holes. If the sound of the exhaust seems unusual or there is a smell of exhaust fumes, immediately locate the trouble and correct it.	<a href="#">MA-19</a>	M
<b>Underbody</b>	The underbody is frequently exposed to corrosive substances such as those used on icy roads or to control dust. It is very important to remove these substances, otherwise rust will form on the floor pan, frame, fuel lines and around the exhaust system. At the end of winter, the underbody should be thoroughly flushed with plain water, being careful to clean those areas where mud and dirt can easily accumulate.	—	N
<b>Fluid leaks</b>	Check under the vehicle for fuel, oil, water or other fluid leaks after the vehicle has been parked for a while. Water dripping from the air conditioner after use is normal. If you should notice any leaks or gasoline fumes are evident, check for the cause and correct it immediately.	—	O

# PERIODIC MAINTENANCE

< PERIODIC MAINTENANCE >

## PERIODIC MAINTENANCE

### Introduction of Periodic Maintenance

INFOID:000000006504565

Two different maintenance schedules are provided, and should be used, depending upon the conditions in which the vehicle is mainly operated. **After 60,000 miles (96,000 km) or 48 months, continue the periodic maintenance at the same mileage/time intervals.**

Schedule 1	Follow Periodic Maintenance Schedule 1 if the driving habits frequently include one or more of the following driving conditions: <ul style="list-style-type: none"> <li>Repeated short trips of less than 5 miles (8 km).</li> <li>Repeated short trips of less than 10 miles (16 km) with outside temperatures remaining below freezing.</li> <li>Operating in hot weather in stop-and-go "rush hour" traffic.</li> <li>Extensive idling and/or low speed driving for long distances, such as police, taxi or door-to-door delivery use.</li> <li>Driving in dusty conditions.</li> <li>Driving on rough, muddy, or salt spread roads.</li> <li>Towing a trailer, using a camper or a car-top carrier.</li> </ul>	Emission Control System Maintenance	<a href="#">MA-6</a>
		Chassis and Body Maintenance	<a href="#">MA-6</a>
Schedule 2	Follow Periodic Maintenance Schedule 2 if none of driving conditions shown in Schedule 1 apply to the driving habits.	Emission Control System Maintenance	<a href="#">MA-8</a>
		Chassis and Body Maintenance	<a href="#">MA-8</a>

### Schedule 1

INFOID:000000006504566

### EMISSION CONTROL SYSTEM MAINTENANCE

Abbreviations: R = Replace. I = Inspect. Correct or replace if necessary. [ ]: At the mileage intervals only

MAINTENANCE OPERATION		MAINTENANCE INTERVAL								Reference Section - Page or - Content Title
Perform at number of miles, kilometers or months, whichever comes first.	Miles x 1,000 (km x 1,000) Months	3.75 (6)	7.50 (12)	11.25 (18)	15 (24)	18.75 (30)	22.5 (36)	26.25 (42)	30 (48)	
Drive belt	NOTE (1)									<a href="#">MA-12</a>
Air cleaner filter	NOTE (2)								[R]	<a href="#">MA-15</a>
EVAP vapor lines									I*	<a href="#">MA-18</a>
Fuel lines									I*	<a href="#">MA-15</a>
Fuel filter	NOTE (3)									-
Engine coolant*	NOTE (4)									<a href="#">MA-12</a>
Engine oil		R	R	R	R	R	R	R	R	<a href="#">MA-16</a>
Engine oil filter (Use genuine NISSAN engine oil filter or equivalent.)		R	R	R	R	R	R	R	R	<a href="#">MA-17</a>
Spark plugs (Iridium-tipped type)	NOTE (5)	Replace every 105,000 miles (168,000 km).								<a href="#">MA-18</a>
Intake & exhaust valve clearance*	NOTE (6)									<a href="#">EM-18</a>

MAINTENANCE OPERATION		MAINTENANCE INTERVAL								Reference Section - Page or - Content Title
Perform at number of miles, kilometers or months, whichever comes first.	Miles x 1,000 (km x 1,000) Months	33.75 (54)	37.5 (60)	41.25 (66)	45 (72)	48.75 (78)	52.5 (84)	56.25 (90)	60 (96)	
Drive belt	NOTE (1)								I*	<a href="#">MA-12</a>
Air cleaner filter	NOTE (2)								[R]	<a href="#">MA-15</a>
EVAP vapor lines									I*	<a href="#">MA-18</a>
Fuel lines									I*	<a href="#">MA-15</a>

# PERIODIC MAINTENANCE

## < PERIODIC MAINTENANCE >

MAINTENANCE OPERATION		MAINTENANCE INTERVAL								Reference Section - Page or - Content Title
Perform at number of miles, kilometers or months, whichever comes first.	Miles x 1,000 (km x 1,000) Months	33.75 (54) 27	37.5 (60) 30	41.25 (66) 33	45 (72) 36	48.75 (78) 39	52.5 (84) 42	56.25 (90) 45	60 (96) 48	
Fuel filter	NOTE (3)									-
Engine coolant*	NOTE (4)									<a href="#">MA-12</a>
Engine oil		R	R	R	R	R	R	R	R	<a href="#">MA-16</a>
Engine oil filter (Use genuine NISSAN engine oil filter or equivalent.)		R	R	R	R	R	R	R	R	<a href="#">MA-17</a>
Spark plugs (Iridium-tipped type)	NOTE (5)	Replace every 105,000 miles (168,000 km).								<a href="#">MA-18</a>
Intake & exhaust valve clearance*	NOTE (6)									<a href="#">EM-18</a>

### NOTE:

- (1) After 60,000 miles (96,000 km) or 48 months, inspect every 15,000 miles (24,000 km) or 12 months. Replace the drive belt if found damaged (or if the auto belt tensioner reading reaches maximum limit).
- (2) If operating mainly in dusty conditions, more frequent maintenance may be required.
- (3) Maintenance-free item. For service procedures, refer to FL section.
- (4) First replacement interval is 105,000 miles (168,000 km) or 84 months. After first replacement, replace every 75,000 miles (120,000 km) or 60 months. Use only Genuine NISSAN Long Life Antifreeze / Coolant (blue) or equivalent with proper mixture ratio of 50% anti-freeze and 50% demineralized or distilled water. Mixing any other type of coolant or the use of non-distilled water will reduce the life expectancy of the factory-fill coolant.
- (5) Replace spark plug when the spark plug gap exceeds 1.4 mm (0.055 in) even if within specified periodic replacement mileage.
- (6) Periodic maintenance is not required. However, if valve noise increases, inspect valve clearance.

\* Maintenance items and intervals with "\*" are recommended by NISSAN for reliable vehicle operation. The owner need not perform such maintenance in order to maintain the emission warranty or manufacturer recall liability. Other maintenance items and intervals are required.

## CHASSIS AND BODY MAINTENANCE

Abbreviations: R = Replace. I = Inspect. Correct or replace if necessary.

MAINTENANCE OPERATION		MAINTENANCE INTERVAL								Reference Section - Page or - Content Title
Perform at number of miles, kilometers or months, whichever comes first.	Miles x 1,000 (km x 1,000) Months	3.75 (6) 3	7.50 (12) 6	11.25 (18) 9	15 (24) 12	18.75 (30) 15	22.5 (36) 18	26.25 (42) 21	30 (48) 24	
Brake lines & cables					I				I	<a href="#">MA-24</a>
Brake pads, rotors, drums & linings			I		I		I		I	<a href="#">MA-24</a> , <a href="#">MA-25</a>
Brake fluid					R				R	<a href="#">MA-24</a>
CVT fluid	NOTE (1)				I				I	<a href="#">MA-19</a> , <a href="#">MA-20</a>
Manual transaxle gear oil	NOTE (2)				I				I	<a href="#">MA-21</a>
Steering gear & linkage, axle & suspension parts			I		I		I		I	<a href="#">MA-26</a> , <a href="#">MA-26</a>
Tire rotation	NOTE (3)									<a href="#">MA-4</a> , <a href="#">MA-22</a>
Front drive shaft boots			I		I		I		I	<a href="#">MA-27</a>
Exhaust system			I		I		I		I	<a href="#">MA-19</a>
In-cabin microfilter					R				R	<a href="#">VTL-6</a>

# PERIODIC MAINTENANCE

## < PERIODIC MAINTENANCE >

MAINTENANCE OPERATION		MAINTENANCE INTERVAL								Reference Section - Page or - Content Title	
		Miles x 1,000 (km x 1,000) Months	33.75 (54) 27	37.5 (60) 30	41.25 (66) 33	45 (72) 36	48.75 (78) 39	52.5 (84) 42	56.25 (90) 45		60 (96) 48
Perform at number of miles, kilometers or months, whichever comes first.											
Brake lines & cables					I					I	<a href="#">MA-24</a>
Brake pads, rotors, drums & linings			I		I		I			I	<a href="#">MA-24</a> , <a href="#">MA-25</a>
Brake fluid					R					R	<a href="#">MA-24</a>
CVT fluid	NOTE (1)				I					I	<a href="#">MA-19</a> , <a href="#">MA-20</a>
Manual transaxle gear oil	NOTE (2)				I					I	<a href="#">MA-21</a>
Steering gear & linkage, axle & suspension parts			I		I		I			I	<a href="#">MA-26</a> , <a href="#">MA-26</a>
Tire rotation	NOTE (3)										<a href="#">MA-4</a> , <a href="#">MA-22</a>
Front drive shaft boots			I		I		I			I	<a href="#">MA-27</a>
Exhaust system			I		I		I			I	<a href="#">MA-19</a>
In-cabin microfilter					R					R	<a href="#">VTL-6</a>

**NOTE:**

(1) If towing a trailer, using a camper or a car-top carrier, or driving on rough or muddy roads, inspect CVT fluid deterioration with CONSULT-III every 60,000 miles (96,000 km), then change CVT fluid NS-2 if necessary. (Refer to [TM-97](#), "CONSULT-III Function (TRANSMISSION)".) And if CONSULT-III is not available, change (not just inspect) CVT fluid NS-2 every 60,000 miles (96,000 km). **Using transmission fluid other than Genuine NISSAN CVT Fluid NS-2 will damage the CVT, which is not covered by the NISSAN new vehicle limited warranty.**

(2) If towing a trailer, using a camper or a car-top carrier, or driving on rough or muddy roads, change (not just inspect) oil at every 30,000 miles (48,000 km) or 24 months.

(3) Refer to "Tire rotation" under the "GENERAL MAINTENANCE" heading earlier in this section.

## Schedule 2

INFOID:000000006504567

## EMISSION CONTROL SYSTEM MAINTENANCE

Abbreviations: R = Replace. I = Inspect. Correct or replace if necessary. [ ]: At the mileage intervals only

MAINTENANCE OPERATION		MAINTENANCE INTERVAL								Reference Section - Page or - Content Title	
		Miles x 1,000 (km x 1,000) Months	7.5 (12) 6	15 (24) 12	22.5 (36) 18	30 (48) 24	37.5 (60) 30	45 (72) 36	52.5 (84) 42		60 (96) 48
Perform at number of miles, kilometers or months, whichever comes first.											
Drive belt	NOTE (1)									I*	<a href="#">MA-12</a>
Air cleaner filter					[R]					[R]	<a href="#">MA-15</a>
EVAP vapor lines					I*					I*	<a href="#">MA-18</a>
Fuel lines					I*					I*	<a href="#">MA-15</a>
Fuel filter	NOTE (2)										-
Engine coolant*	NOTE (3)										<a href="#">MA-12</a>
Engine oil			R	R	R	R	R	R	R	R	<a href="#">MA-16</a>
Engine oil filter (Use genuine NISSAN engine oil filter or equivalent.)			R	R	R	R	R	R	R	R	<a href="#">MA-17</a>
Spark plugs (Iridium-tipped type)	NOTE (4)	Replace every 105,000 miles (168,000 km).									<a href="#">MA-18</a>
Intake & exhaust valve clearance*	NOTE (5)										<a href="#">EM-18</a>

**NOTE:**

(1) After 60,000 miles (96,000 km) or 48 months, inspect every 15,000 miles (24,000 km) or 12 months. Replace the drive belt if found damaged or if the auto belt tensioner reading reaches maximum limit.

(2) Maintenance-free item. For service procedures, refer to FL section.



# PERIODIC MAINTENANCE

## < PERIODIC MAINTENANCE >

(3) First replacement interval is 105,000 miles (168,000 km) or 84 months. After first replacement, replace every 75,000 miles (120,000 km) or 60 months. Use only Genuine NISSAN Long Life Antifreeze / Coolant (blue) or equivalent with proper mixture ratio of 50% anti-freeze and 50% demineralized or distilled water. Mixing any other type of coolant or the use of non-distilled water will reduce the life expectancy of the factory-fill coolant.

(4) Replace spark plug when the spark plug gap exceeds 1.4 mm (0.055 in) even if within specified periodic replacement mileage.

(5) Periodic maintenance is not required. However, if valve noise increases, inspect valve clearance.

\* Maintenance items and intervals with "\*" are recommended by NISSAN for reliable vehicle operation. The owner need not perform such maintenance in order to maintain the emission warranty or manufacturer recall liability. Other maintenance items and intervals are required.

## CHASSIS AND BODY MAINTENANCE

Abbreviations: R = Replace. I = Inspect. Correct or replace if necessary.

MAINTENANCE OPERATION	Miles x 1,000 (km x 1,000) Months	MAINTENANCE INTERVAL								Reference Sec- tion - Page or - Content Title
		7.5 (12) 6	15 (24) 12	22.5 (36) 18	30 (48) 24	37.5 (60) 30	45 (72) 36	52.5 (84) 42	60 (96) 48	
Brake lines & cables			I		I		I		I	<a href="#">MA-24</a>
Brake pads, rotors, drums & linings			I		I		I		I	<a href="#">MA-24</a> , <a href="#">MA-25</a>
Brake fluid					R				R	<a href="#">MA-24</a>
CVT fluid	NOTE (1)		I		I		I		I	<a href="#">MA-19</a>
Manual transaxle gear oil	NOTE (2)		I		I		I		I	<a href="#">MA-21</a>
Steering gear & linkage, axle & suspension parts					I				I	<a href="#">MA-26</a> , <a href="#">MA-26</a>
Tire rotation	NOTE (3)									<a href="#">MA-4</a> , <a href="#">MA-22</a>
Front drive shaft boots			I		I		I		I	<a href="#">MA-27</a>
Exhaust system					I				I	<a href="#">MA-19</a>
In-cabin microfilter			R		R		R		R	<a href="#">VTL-6</a>

### NOTE:

(1) Using transmission fluid other than Genuine Nissan CVT Fluid NS-2 will damage the CVT, which is not covered by the NISSAN new vehicle limited warranty.

(2) If towing a trailer, using a camper or a car-top carrier, or driving on rough or muddy roads, change (not just inspect) oil at every 30,000 miles (48,000 km) or 24 months.

(3) Refer to "Tire rotation" under the "GENERAL MAINTENANCE" heading earlier in this section.

# RECOMMENDED FLUIDS AND LUBRICANTS

< PERIODIC MAINTENANCE >

## RECOMMENDED FLUIDS AND LUBRICANTS

### Fluids and Lubricants

INFOID:000000006504568

		Capacity (Approximate)			Recommended Fluids/Lubricants
		US measure	Imp measure	Liter	
Engine oil Drain and refill	With oil filter change	4-3/8 qt	3-5/8 qt	4.1	Engine oil with API Certification Mark* <sup>1</sup> Viscosity SAE 5W-30
	Without oil filter change	4 qt	3-3/8 qt	3.8	
Dry engine (Overhaul)		5-1/8 qt	4-3/8 qt	4.9	
Cooling system	With reservoir tank	CVT models	7-1/2 qt	6-1/4 qt	Pre-diluted Genuine NISSAN Long Life Antifreeze/Coolant (blue) or equivalent
		M/T models	7-1/4 qt	6 qt	
	Reservoir tank	3/4 qt	5/8 qt	0.7	
CVT fluid		7-7/8 qt	6-1/2 qt	7.4	Genuine NISSAN CVT Fluid NS-2 * <sup>2</sup>
Manual transaxle gear oil		4-1/4 pt	3-1/2 pt	2.0	Genuine NISSAN gear Oil (Chevron Texaco ETL 8997B) 75W-80, or equivalent * <sup>3</sup>
Brake and clutch fluid		—	—	—	Genuine NISSAN Super Heavy Duty Brake Fluid* <sup>4</sup> or equivalent DOT 3 (US FMVSS No. 116)
Multi-purpose grease		—	—	—	NLGI No. 2 (Lithium soap base)
Windshield washer fluid		—	—	—	Genuine NISSAN Windshield Washer Concentrate Cleaner & Antifreeze or equivalent
Fuel recommendation		—	—	—	Refer to <a href="#">Gl-32. "Fuel"</a>

\*1: For additional information, see "Engine Oil Recommendation".

\*2: Use only Genuine NISSAN CVT Fluid NS-2. Using transmission fluid other than Genuine NISSAN CVT Fluid NS-2 will damage the CVT, which is not covered by the NISSAN new vehicle limited warranty.

\*3: If Genuine NISSAN gear oil is not available, API GL-4, Viscosity SAE 75W-80 may be used as a temporary replacement. However, use Genuine NISSAN gear oil as soon as it is available.

\*4: Available in mainland U.S.A. through a NISSAN dealer.

### Engine Oil Recommendation

INFOID:000000006504569

NISSAN recommends the use of an energy conserving oil in order to improve fuel economy. Select only engine oils that meet the American Petroleum Institute (API) certification and International Lubricant Standardization and Approval Committee (ILSAC) certification and SAE viscosity standard. These oils have the API certification mark on the front of the container. Oils which do not have the specified quality label should not be used as they could cause engine damage.

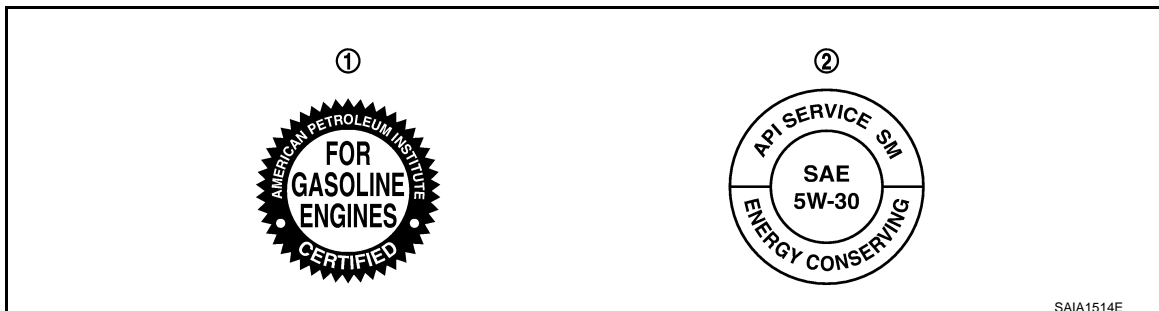

1. API certification mark

2. API service symbol

SAIA1514E

# RECOMMENDED FLUIDS AND LUBRICANTS

< PERIODIC MAINTENANCE >

## Anti-Freeze Coolant Mixture Ratio

INFOID:000000006504570

The engine cooling system is filled at the factory with a pre-diluted mixture of 50% Genuine NISSAN Long Life Antifreeze/Coolant (blue) and 50% water to provide year-round anti-freeze and coolant protection. The anti-freeze solution contains rust and corrosion inhibitors. Additional engine cooling system additives are not necessary.

### **WARNING:**

- Never remove the radiator or coolant reservoir cap when the engine is hot. Wait until the engine and radiator cool down. Serious burns could be caused by high pressure fluid escaping from the radiator. See precautions in "If your vehicle overheats" found in the "In case of emergency" section of this manual.
- The radiator is equipped with a pressure type radiator cap. To prevent engine damage, use only a genuine NISSAN radiator cap.

### **CAUTION:**

- When adding or replacing coolant, be sure to use only Genuine NISSAN Long Life Antifreeze/Coolant (blue) or equivalent. Genuine NISSAN Long Life Antifreeze/Coolant (blue) is pre-diluted to provide antifreeze protection to -34°F (-37°C). If additional freeze protection is needed due to weather where you operate your vehicle, add Genuine NISSAN Long Life Antifreeze/Coolant (blue) concentrate following the directions on the container. If an equivalent coolant other than Genuine NISSAN Long Life Antifreeze/Coolant (blue) is used, follow the coolant manufacturer's instructions to maintain minimum antifreeze protection to -34°F (-37°C). The use of other types of coolant solutions other than Genuine NISSAN Long Life Antifreeze/Coolant (blue) or equivalent may damage the engine cooling system.
- The life expectancy of the factory-fill coolant is 105,000 miles (168,000 km) or 7 years. Mixing any other type of coolant other than Genuine NISSAN Long Life Antifreeze/Coolant (blue), including Genuine NISSAN Long Life Antifreeze/Coolant (green), or the use of non-distilled water will reduce the life expectancy of the factory-fill coolant. Refer to the Nissan Service and Maintenance Guide for more details.

A  
B  
C  
D  
E  
F  
G  
H  
I  
J  
K  
L  
M  
N  
O

MA

# ENGINE MAINTENANCE

< PERIODIC MAINTENANCE >

## ENGINE MAINTENANCE

### DRIVE BELT

#### DRIVE BELT : Exploded View

INFOID:000000006504571

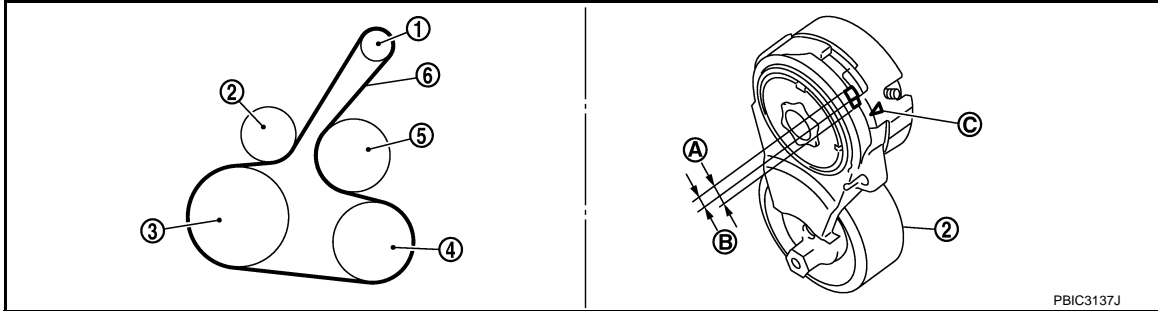

- |  |   |                      |
|--|---|----------------------|
| 1. Alternator  | 2. Drive belt auto-tensioner              | 3. Crankshaft pulley |
| 4. A/C compressor (models with A/C)<br>Idler pulley (models without A/C) | 5. Water pump                             | 6. Drive belt        |
| A. Possible use range  | B. Range when new drive belt is installed | C. Indicator         |

#### DRIVE BELT : Checking

INFOID:000000006504572

##### **WARNING:**

**Perform this step when engine is stopped.**

- Check that the indicator (C) (notch on fixed side) of drive belt auto-tensioner is within the possible use range (A) in the figure.

##### **NOTE:**

- Check the drive belt auto-tensioner indication when the engine is cold.
- When new drive belt is installed, the indicator (notch on fixed side) should be within the range (B) in the figure.
- Visually check entire drive belt for wear, damage or cracks.
- If the indicator (notch on fixed side) is out of the possible use range or belt is damaged, replace drive belt.

#### DRIVE BELT : Tension Adjustment

INFOID:000000006504573

Refer to : [EM-114, "Drive Belt"](#).

## ENGINE COOLANT

### ENGINE COOLANT : Draining

INFOID:000000006504574

##### **WARNING:**

- **Never remove radiator cap when engine is hot. Serious burns may occur from high-pressure engine coolant escaping from radiator.**
- **Wrap a thick cloth around the radiator cap. Slowly turn it a quarter of a turn to release built-up pressure. Then turn it all the way.**

1. Remove engine under cover.

# ENGINE MAINTENANCE

## < PERIODIC MAINTENANCE >

- Open radiator drain plug (A) at the bottom of radiator, and then remove radiator cap.

↩ : Vehicle front

### CAUTION:

**Perform this step when engine is cold.**

- When draining all of engine coolant in the system, open water drain plugs on cylinder block. Refer to [EM-88, "Disassembly and Assembly"](#).

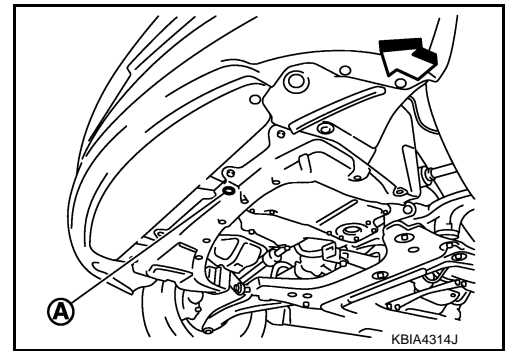

- Remove reservoir tank if necessary, and drain engine coolant and clean reservoir tank before installing. Refer to [CO-15, "Exploded View"](#).
- Check drained engine coolant for contaminants such as rust, corrosion or discoloration. If contaminated, flush the engine cooling system. Refer to [MA-14, "ENGINE COOLANT : Flushing"](#).

## ENGINE COOLANT : Refilling

INFOID:000000006952115

### CAUTION:

- Before start working, turn off the automatic air conditioner and the blower motor.
- Do not put additive such as waterleak preventive, since it may cause cooling waterway clogging.
- When refilling use Genuine NISSAN Long Life Antifreeze/Coolant (blue) or equivalent in its quality mixed with water (distilled or demineralized). Refer to [MA-10, "Fluids and Lubricants"](#).

- Install reservoir tank if removed and radiator drain plug.

### CAUTION:

**Be sure to clean drain plug and install with new O-ring.**

**Radiator drain plug** : Refer to [CO-15, "Exploded View"](#).

- If water drain plugs on cylinder block are removed, close and tighten them. Refer to [EM-88, "Disassembly and Assembly"](#).
- Check that each hose clamp has been firmly tightened.
  - Remove air duct (between air cleaner case and electric throttle control actuator). Refer to [EM-24, "Exploded View"](#).
  - Disconnect heater hose (1) at position (↔) in the figure.

↩ : Vehicle front

- Enhance heater hose as high as possible.

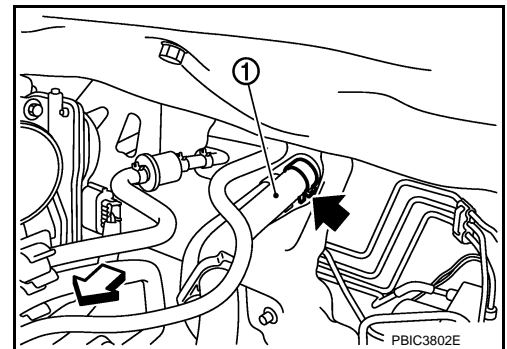

- Fill radiator (1) to specified level.

### CAUTION:

**Never adhere the engine coolant to electronic equipments (alternator etc.).**

- Pour coolant slowly of less than 2 ℓ (2-1/8 US qt, 1-3/4 Imp qt) a minute to allow air in system to escape.
- When engine coolant overflows disconnected heater hose, connect heater hose, and continue filling the engine coolant.

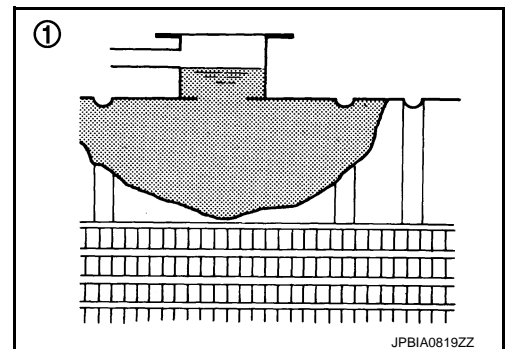

# ENGINE MAINTENANCE

## < PERIODIC MAINTENANCE >

### Engine coolant capacity (With reservoir tank at "MAX" level)

Refer to [CO-26, "Periodical Maintenance Specification"](#).

6. Refill reservoir tank to "MAX" level line with engine coolant.

A : MAX

B : MIN

### Reservoir tank engine coolant capacity (At "MAX" level)

Refer to [CO-26, "Periodical Maintenance Specification"](#).

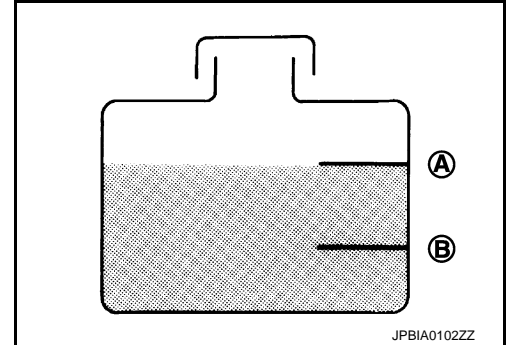

7. Install air duct (between air cleaner case and electric throttle control actuator). Refer to [EM-24, "Exploded View"](#).
8. Install radiator cap.
9. Warm up engine until opening thermostat. Standard for warming-up time is approximately 10 minutes at 3,000 rpm.
  - Check thermostat opening condition by touching radiator hose (lower) to see a flow of warm water.

**CAUTION:**  
**Watch water temperature gauge so as not to overheat engine.**
10. Stop the engine and cool down to less than approximately 50°C (122°F).
  - Cool down using fan to reduce the time.
  - If necessary, refill radiator up to filler neck with engine coolant.

**CAUTION:**  
**Never adhere the engine coolant to electronic equipments (alternator etc.).**
11. Refill reservoir tank to "MAX" level line with engine coolant.
12. Repeat steps 5 through 10 two or more times with radiator cap installed until engine coolant level no longer drops.
13. Check cooling system for leakage with engine running.
14. Warm up the engine, and check for sound of engine coolant flow while running engine from idle up to 3,000 rpm with heater temperature controller set at several position between "COOL" and "WARM".
  - Sound may be noticeable at heater unit.
15. Repeat step 14 three times.
16. If sound is heard, bleed air from cooling system by repeating step 5 through 10 until reservoir tank level no longer drops.

## ENGINE COOLANT : Flushing

INFOID:000000006504576

1. Install reservoir tank if removed and radiator drain plug.

**CAUTION:**

**Be sure to clean drain plug and install with new O-ring.**

**Radiator drain plug** : Refer to [CO-15, "Exploded View"](#).

- If water drain plugs on cylinder block are removed, close and tighten them. Refer to [EM-88, "Disassembly and Assembly"](#).
2. Remove air duct (between air cleaner case and electric throttle control actuator). Refer to [EM-24, "Exploded View"](#).

# ENGINE MAINTENANCE

## < PERIODIC MAINTENANCE >

3. Disconnect heater hose (1) at position (←) in the figure.

← : Vehicle front

- Enhance heater as high as possible.

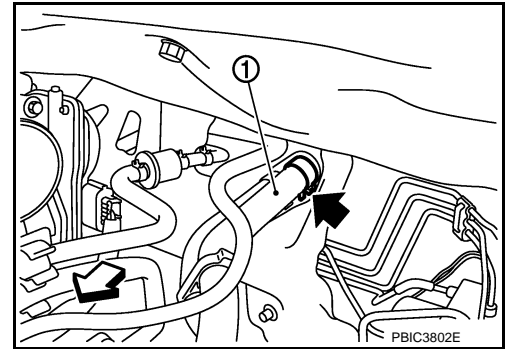

4. Fill radiator and reservoir tank with water and reinstall radiator cap.
  - When engine coolant over flows disconnected heater hose, connect heater hose, and continue filling the engine coolant.
5. Install air duct (between air cleaner case and electric throttle control actuator). Refer to [EM-24. "Exploded View"](#).
6. Run the engine and warm it up to normal operating temperature.
7. Rev the engine two or three times under no-load.
8. Stop the engine and wait until it cools down.
9. Drain water from the system. Refer to [MA-12. "ENGINE COOLANT : Draining"](#).
10. Repeat steps 1 through 9 until clear water begins to drain from radiator.

## FUEL LINES

### FUEL LINES : Inspection

INFOID:000000006504577

Inspect fuel lines, fuel filler cap, and fuel tank for improper attachment, leakage, cracks, damage, loose connections, chafing or deterioration.

- A : Engine
- B : Fuel line
- C : Fuel tank

If necessary, repair or replace damaged parts.

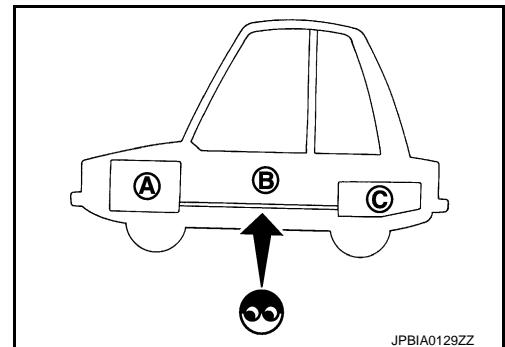

## AIR CLEANER FILTER

### AIR CLEANER FILTER : Removal and Installation

INFOID:000000006504578

#### REMOVAL

1. Push the tabs (A) of both ends of the air cleaner cover (1) into the inside (B).
2. Pull up the air cleaner cover forward (C) and remove it.

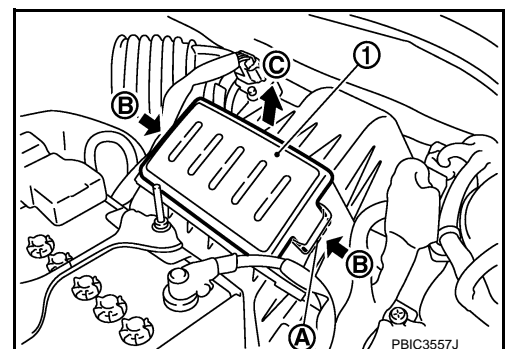

A  
B  
C  
D  
E  
F  
G  
H  
I  
J  
K  
L  
M  
N  
O  
MA

# ENGINE MAINTENANCE

## < PERIODIC MAINTENANCE >

3. Remove the air cleaner filter (1) and holder (2) assembly from the air cleaner case.
4. Remove the air cleaner filter from the holder.

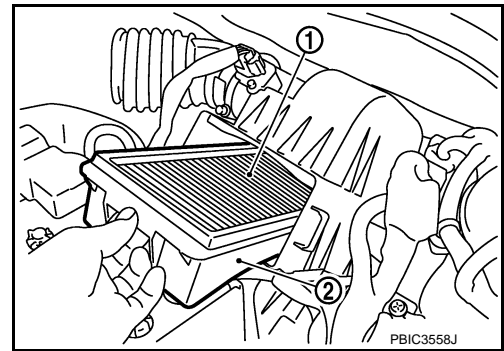

## INSTALLATION

Note the following, and install in the reverse order of removal.

- Install the air cleaner cover (1) in the direction as shown in the figure.

- 2 : Air cleaner filter
- 3 : Holder

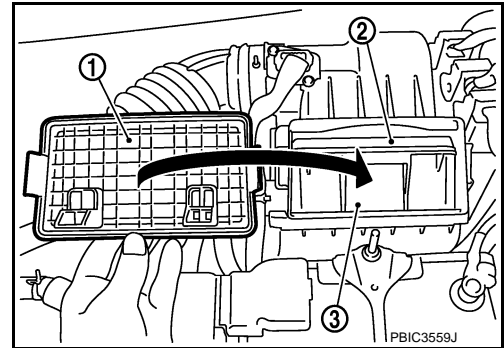

## ENGINE OIL

### ENGINE OIL : Draining

INFOID:000000006504579

#### **WARNING:**

- Be careful not to get burned, as engine oil may be hot.
- Prolonged and repeated contact with used engine oil may cause skin cancer. Try to avoid direct skin contact with used engine oil. If skin contact is made, wash thoroughly with soap or hand cleaner as soon as possible.

1. Warm up the engine, and check for engine oil leakage from engine components. Refer to [LU-7, "Inspection"](#).
2. Stop the engine and wait for 10 minutes.
3. Loosen oil filler cap.
4. Remove drain plug and then drain engine oil.

### ENGINE OIL : Refilling

INFOID:000000006504580

1. Install drain plug with new drain plug washer. Refer to [EM-33, "Exploded View"](#).

#### **CAUTION:**

Be sure to clean drain plug and install with new drain plug washer.

**Tightening torque** : Refer to [EM-33, "Exploded View"](#).

2. Refill with new engine oil.  
**Engine oil specification and viscosity:** Refer to [MA-10, "Fluids and Lubricants"](#).

**Engine oil capacity** : Refer to [LU-14, "Periodical Maintenance Specification"](#).

#### **CAUTION:**

- The refill capacity depends on the engine oil temperature and drain time. Use these specifications for reference only.
  - Always use oil level gauge to determine the proper amount of engine oil in the engine.
3. Warm up engine and check area around drain plug and oil filter for engine oil leakage.



# ENGINE MAINTENANCE

## < PERIODIC MAINTENANCE >

4. Stop engine and wait for 10 minutes.
5. Check the engine oil level. Refer to [LU-7, "Inspection"](#).

## OIL FILTER

### OIL FILTER : Removal and Installation

INFOID:000000006504581

#### REMOVAL

1. Remove engine under cover. Refer to [EXT-23, "Exploded View"](#).
2. Using oil filter wrench [SST: KV10115801 (J-38956)] (A), remove oil filter.

↶ : Vehicle front

#### CAUTION:

- Oil filter is provided with relief valve. Use genuine NISSAN oil filter or equivalent.
- Be careful not to get burned when engine and engine oil may be hot.
- When removing, prepare a shop cloth to absorb any engine oil leakage or spillage.
- Completely wipe off any engine oil that adheres to engine and vehicle.

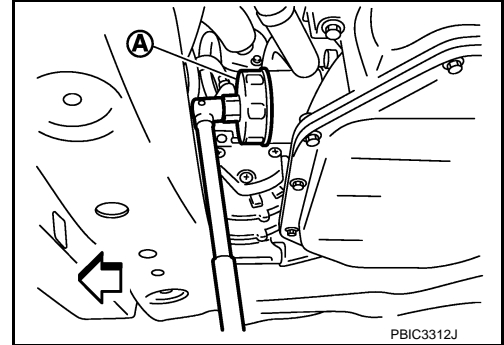

#### INSTALLATION

1. Remove foreign materials adhering to the oil filter installation surface.
2. Apply new engine oil to the oil seal contact surface of new oil filter.

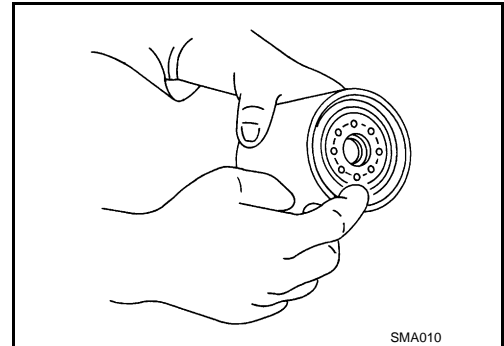

3. Screw oil filter manually until it touches the installation surface, then tighten it by 2/3 turn (A). Or tighten to specification.

#### Oil filter:

: 17.7 N-m (1.8 kg-m, 13 ft-lb)

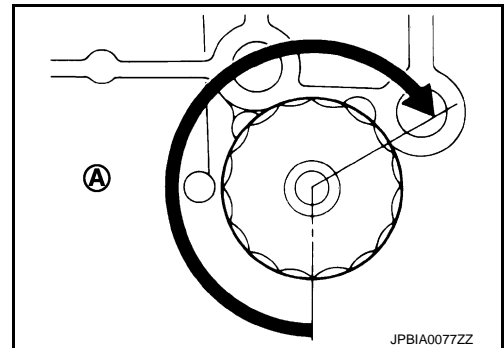

### OIL FILTER : Inspection

INFOID:000000006504582

#### INSPECTION AFTER INSTALLATION

1. Check the engine oil level. Refer to [LU-7, "Inspection"](#).
2. Start the engine, and check that there is no leakage of engine oil.
3. Stop the engine and wait for 10 minutes.
4. Check the engine oil level, and adjust the level. Refer to [LU-7, "Inspection"](#).

## SPARK PLUG

A  
B  
C  
D  
E  
F  
G  
H  
I  
J  
K  
L  
M  
N  
O

MA

# ENGINE MAINTENANCE

< PERIODIC MAINTENANCE >

## SPARK PLUG : Removal and Installation

INFOID:000000006504583

### REMOVAL

1. Remove ignition coil. Refer to [EM-41, "Exploded View"](#).
2. Remove spark plug with a spark plug wrench (commercial service tool).

a : 14 mm (0.55 in)

#### CAUTION:

Never drop or shock spark plug.

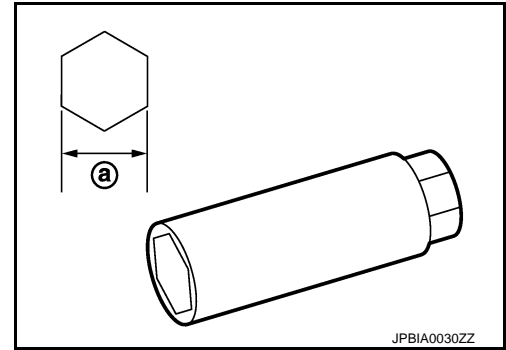

### INSTALLATION

Install in the reverse order of removal.

## SPARK PLUG : Inspection

INFOID:000000006504584

### INSPECTION AFTER REMOVAL

Use the standard type spark plug for normal condition.

Spark plug (Standard type) : Refer to [EM-114, "Spark Plug"](#).

#### CAUTION:

- Never drop or shock spark plug.
- Never use a wire brush for cleaning.
- If plug tip is covered with carbon, spark plug cleaner may be used.

Cleaner air pressure : Less than 588 kPa (6 kg/cm<sup>2</sup>, 85 psi)

Cleaning time : Less than 20 seconds

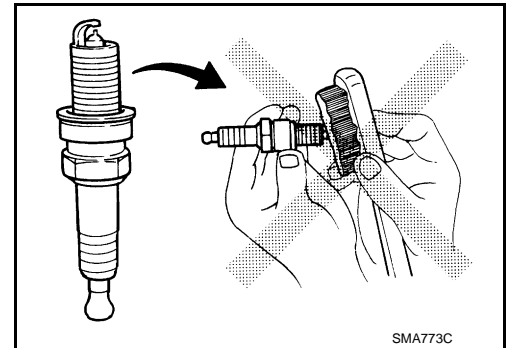

- Spark plug gap adjustment is not required between replacement intervals.
- Measure spark plug gap. when it exceeds the limit, replace spark plug even if it is with in the specified replacement mileage. Refer to [EM-114, "Spark Plug"](#).

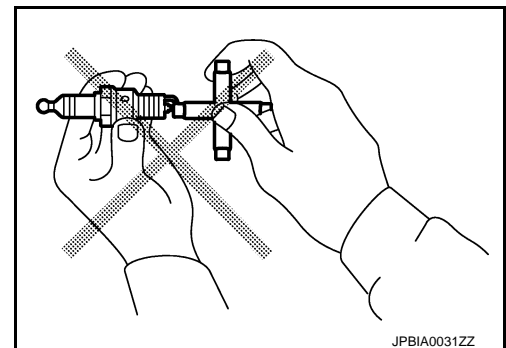

## EVAP VAPOR LINES

### EVAP VAPOR LINES : Inspection

INFOID:000000006504585

1. Visually inspect EVAP vapor lines for improper attachment and for cracks, damage, loose connections, chafing and deterioration. Refer to [EC-489, "Inspection"](#).
2. Inspect fuel tank filler cap vacuum relief valve for clogging, sticking, etc.  
Refer to [EC-313, "Component Inspection"](#) (EXCEPT FOR CALIFORNIA), [EC-803, "Component Inspection"](#) (FOR CALIFORNIA).

# CHASSIS MAINTENANCE

< PERIODIC MAINTENANCE >

## CHASSIS MAINTENANCE

### EXHAUST SYSTEM

#### EXHAUST SYSTEM : Inspection

INFOID:000000006504586

Check exhaust pipes, muffler, and mounting for improper attachment, leakage, cracks, damage or deterioration.

- If anything is found, repair or replace damaged parts.

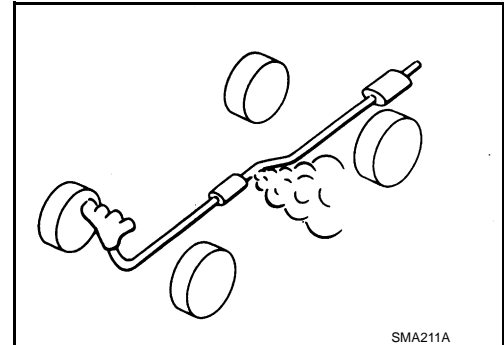

### CVT FLUID

#### CVT FLUID : Inspection

INFOID:000000006504587

##### Level check

Check fluid level in HOT state [CVT fluid temperature is between 50 to 80°C (122 to 176°F)], according to the following procedures.

1. Visually check that CVT fluid leakage from transaxle assembly is not detected.
2. After engine warms up, drive the vehicle in an urban area for approximately 10 minutes.

##### **NOTE:**

When ambient temperature is 20°C (68°F), driving vehicle for approximately 10 minutes in an urban area ordinarily warms up CVT fluid temperature between 50 to 80°C (122 to 176°F).

3. Park the vehicle on a level surface.
4. Fully apply parking brake.
5. Adjust engine speed at idle state.
6. Shift selector lever through entire position from "P" to "D" while depressing brake pedal.
7. Press claw of CVT fluid level gauge lock to unlock.
8. Remove CVT fluid level gauge from CVT fluid charging pipe.
9. Wipe CVT fluid that is on CVT fluid level gauge.

##### **CAUTION:**

**Always use shop paper when wiping off CVT fluid that is on CVT fluid level gauge.**

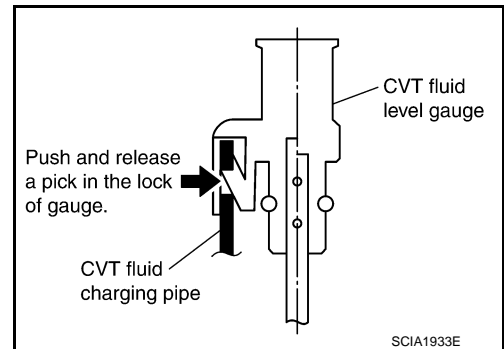

10. Rotate CVT fluid level gauge 180° from installed state.
11. Inset CVT fluid level gauge until it contacts CVT fluid charging pipe end.

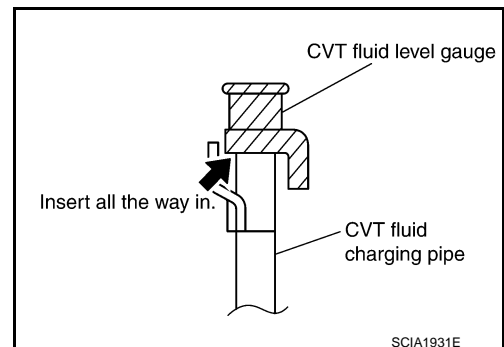

12. Check that CVT fluid level is within the specified level of CVT fluid level gauge (MAX side).

A  
B  
C  
D  
E  
F  
G  
H  
I  
J  
K  
L  
M  
N  
O

MA

# CHASSIS MAINTENANCE

## < PERIODIC MAINTENANCE >

### CAUTION:

- After level check, when returning CVT fluid level gauge to the original state, insert CVT fluid level gauge to CVT fluid charging pipe until it is locked.
- Always use shop paper when wiping off CVT fluid that is on CVT fluid level gauge.

### CVT FLUID CONDITION

Check CVT fluid condition.

- If CVT fluid is very dark or smells burned, check operation of transaxle assembly. Flush cooling system after repair of transaxle assembly.
- If CVT fluid contains frictional material (clutches, brakes, etc.), replace radiator and flush cooler line using cleaning solvent and compressed air after repair of transaxle assembly. Refer to [TM-225. "CVT FLUID COOLER HOSE : Exploded View"](#).



ATA0022D

Fluid status	Conceivable cause	Required operation
Varnished (viscous varnish state)	CVT fluid become degraded due to high temperatures	<ul style="list-style-type: none"> <li>• Replace the CVT fluid.</li> <li>• Check the transaxle assembly and the vehicle for malfunctions (wire harnesses, cooler pipes, etc.)</li> </ul>
Milky white or cloudy	Water in the fluid	<ul style="list-style-type: none"> <li>• Replace the CVT fluid.</li> <li>• Check for places where water is getting in.</li> </ul>
Large amount of metal powder mixed in	Unusual wear of sliding parts within transaxle assembly	<ul style="list-style-type: none"> <li>• Replace the CVT fluid.</li> <li>• Check for improper operation of the transaxle assembly.</li> </ul>

### CVT FLUID : Changing

INFOID:000000006504588

1. Remove drain plug from oil pan and then the CVT fluid.
2. Remove drain plug gasket from drain plug.
3. Install drain plug gasket to drain plug.

### CAUTION:

**Never reuse drain plug gasket.**

4. Install drain plug to oil pan.

 : [TM-219. "Exploded View"](#)

5. Fill CVT fluid from CVT fluid charging pipe to the specified level.

**CVT fluid and fluid capacity** : [TM-234. "General Specification"](#)

### CAUTION:

- Always use the specified fluid. If use, misuse, or mixing of fluid other than the specified fluid occurs, original performance cannot be obtained or it may cause serious malfunctions.
- CVT fluid is not reusable. Never reuse CVT fluid.
- Always use shop paper. Never use shop cloth.
- After replacement, always perform CVT fluid leakage check.
- Delete CVT fluid deterioration date with CONSULT-III after changing CVT fluid.

6. After engine warms up, drive the vehicle in an urban area for approximately 10 minutes.

### NOTE:

When ambient temperature is 20°C (68°F), it takes about 10 minutes for the CVT fluid to warm up to 50 to 80°C (122 to 176°F).

7. Check CVT fluid level and condition. Refer to [MA-19. "CVT FLUID : Inspection"](#).
8. Repeat steps 1 to 6 if CVT fluid has been contaminated.

### GEAR OIL

# CHASSIS MAINTENANCE

< PERIODIC MAINTENANCE >

## GEAR OIL : Inspection

INFOID:000000006504589

### OIL LEAKAGE

Make sure that gear oil is not leaking from transaxle or around it.

### OIL LEVEL

1. Remove filler plug (1) and gasket from transaxle case.
2. Check the oil level from filler plug mounting hole as shown in the figure.

**CAUTION:**

**Never start engine while checking oil level.**

3. Set a gasket on filler plug and then install it to transaxle case.

**CAUTION:**

**Never reuse gasket.**

4. Tighten filler plug to the specified torque. Refer to [TM-26, "Exploded View"](#).

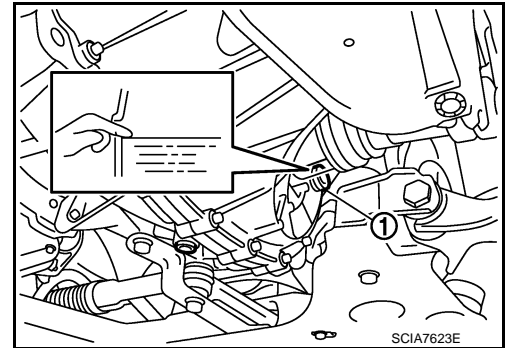

## GEAR OIL : Draining

INFOID:000000006504590

1. Start engine and let it run to warm up transaxle.
2. Stop engine. Remove drain plug (1) and gasket, using a socket [Commercial service tool] and then drain gear oil.
3. Set a gasket on drain plug and install it to clutch housing, using a socket [Commercial service tool].

**CAUTION:**

**Never reuse gasket.**

4. Tighten drain plug to the specified torque. Refer to [TM-26, "Exploded View"](#).

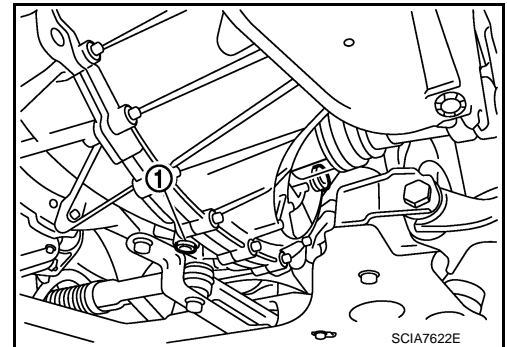

## GEAR OIL : Refilling

INFOID:000000006504591

1. Remove filler plug (1) and gasket from transaxle case.
2. Fill with new gear oil until oil level reaches the specified limit at filler plug mounting hole as shown in the figure.

**Oil grade and viscosity** : Refer to [MA-10, "Fluids and Lubricants"](#).

**Oil capacity** : Refer to [TM-62, "General Specification"](#).

3. After refilling gear oil, check the oil level. Refer to [MA-21, "GEAR OIL : Inspection"](#).

4. Set a gasket on filler plug and then install it to transaxle case.

**CAUTION:**

**Never reuse gasket.**

5. Tighten filler plug to the specified torque. Refer to [TM-26, "Exploded View"](#).

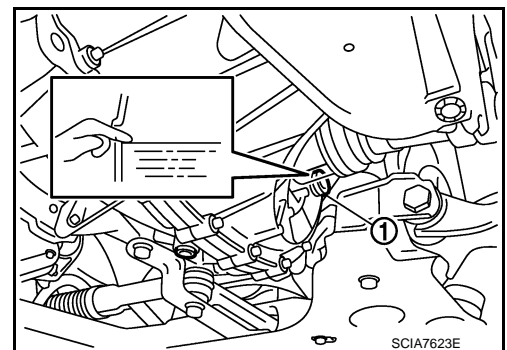

## CLUTCH FLUID

### CLUTCH FLUID : Inspection

INFOID:000000006504592

### FLUID LEVEL

A  
B  
C  
D  
E  
F  
G  
H  
I  
J  
K  
L  
M  
N  
O

MA

# CHASSIS MAINTENANCE

## < PERIODIC MAINTENANCE >

- Check that the fluid level in the reservoir tank is within the specified range (MAX – MIN lines).
- Visually check for any clutch fluid leakage around the reservoir tank.
- Check the clutch system for any leakage if the fluid level is extremely low (lower than MIN).

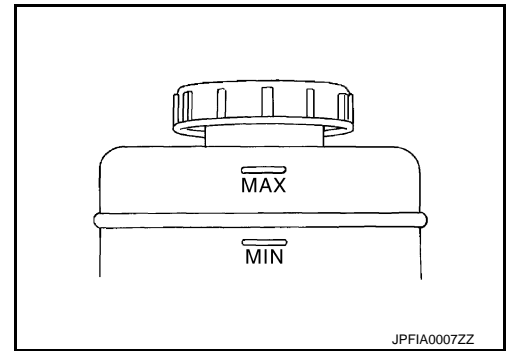

## FLUID LEAKAGE

- Check clutch line for cracks, deterioration or other damage. Replace any damaged parts.
- Check for fluid leakage by fully depressing clutch pedal while engine is running.

### **CAUTION:**

**If leakage occurs around joints, reinstall the joints or, if necessary, replace damaged parts.**

## WHEELS (BONDING WEIGHT TYPE)

### WHEELS (BONDING WEIGHT TYPE) : Adjustment

INFOID:000000006504593

### BALANCING WHEELS (BONDING WEIGHT TYPE)

#### Preparation Before Adjustment

Using releasing agent, remove double-faced adhesive tape from the road wheel.

### **CAUTION:**

- **Be careful not to scratch the road wheel during removal.**
- **After removing double-faced adhesive tape, wipe clean traces of releasing agent from the road wheel.**

#### Wheel Balance Adjustment

If a tire balance machine has adhesion balance weight mode settings and drive-in weight mode setting, select and adjust a drive-in weight mode suitable for road wheels.

1. Set road wheel on tire balance machine using the center hole as a guide. Start the tire balance machine.
2. When inner and outer unbalance values are shown on the tire balance machine indicator, multiply outer unbalance value by 5/3 to determine balance weight that should be used. Select the outer balance weight with a value closest to the calculated value above and install to the designated outer position of, or at the designated angle in relation to the road wheel.

### **CAUTION:**

- **Do not install the inner balance weight before installing the outer balance weight.**
- **Before installing the balance weight, be sure to clean the mating surface of the road wheel.**

- a. Indicated unbalance value  $\times 5/3 =$  balance weight to be installed

#### **Calculation example:**

23 g (0.81 oz)  $\times 5/3 = 38.33$  g (1.35 oz)  $\Rightarrow$  40 g (1.41 oz) balance weight (closer to calculated balance weight value)

#### **NOTE:**

Note that balance weight value must be closer to the calculated balance weight value.

#### **Example:**

37.4  $\Rightarrow$  35 g (1.23 oz)

37.5  $\Rightarrow$  40 g (1.41 oz)

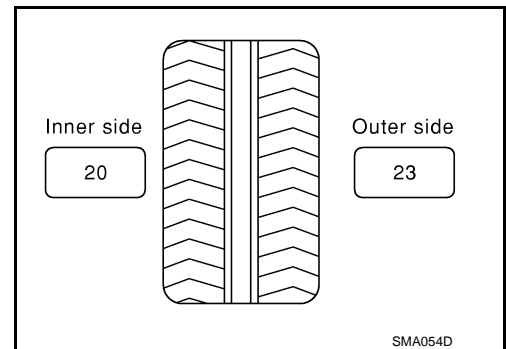

- b. Installed balance weight in the position.

# CHASSIS MAINTENANCE

## < PERIODIC MAINTENANCE >

- When installing balance weight (1) to road wheels, set it into the grooved area (A) on the inner wall of the road wheel as shown in the figure so that the balance weight center (B) is aligned with the tire balance machine indication position (angle) (C).

**CAUTION:**

- Always use genuine NISSAN adhesion balance weights.
- Balance weights are non-reusable; always replace with new ones.
- Do not install more than three sheets of balance weight.

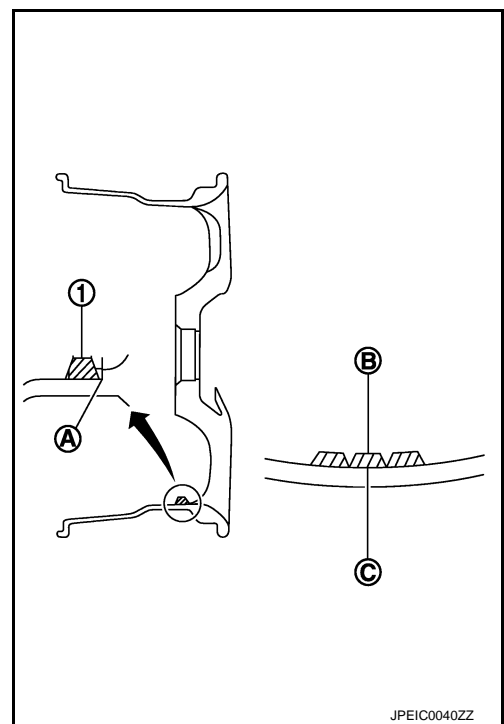

- If calculated balance weight value exceeds 50 g (1.76 oz), install two balance weight sheets in line with each other as shown in the figure.

**CAUTION:**

**Do not install one balance weight sheet on top of another.**

- Start the tire balance machine again.
- Install drive-in balance weight on inner side of road wheel in the tire balance machine indication position (angle).

**CAUTION:**

**Do not install more than two balance weight.**

- Start the tire balance machine. Make sure that inner and outer residual unbalance values are 10 g (0.35 oz) each or below.
- If either residual unbalance value exceeds 10 g (0.35 oz), repeat installation procedures.

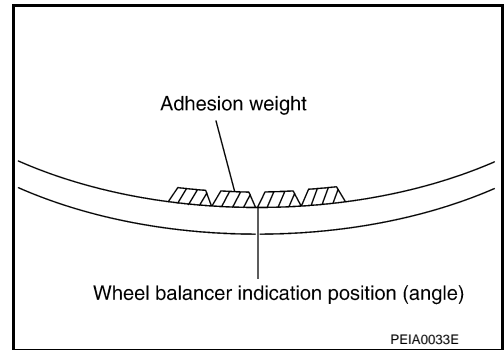

**Limit**

**Dynamic (At flange) :** Refer to [WT-53, "Road Wheel"](#).

**Static (At flange) :** Refer to [WT-53, "Road Wheel"](#).

## TIRE ROTATION

- Follow the maintenance schedule for tire rotation service intervals. Refer to [MA-4, "Explanation of General Maintenance"](#).
- When installing the wheel, tighten wheel nuts to the specified torque.

**CAUTION:**

- When installing wheels, tighten them diagonally by dividing the work two to three times in order to prevent the wheels from developing any distortion.
- Be careful not to tighten wheel nut at torque exceeding the criteria for preventing strain of disc rotor.
- Use NISSAN genuine wheel nuts for aluminum wheels.

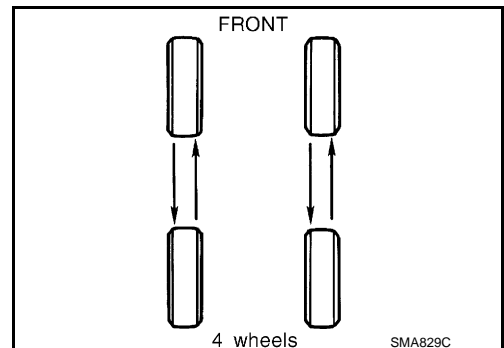

**Wheel nuts tightening torque :** Refer to [WT-45, "Exploded View"](#).

## BRAKE FLUID LEVEL AND LEAKS

A  
B  
C  
D  
E  
F  
G  
H  
I  
J  
K  
L  
M  
N  
O

MA

# CHASSIS MAINTENANCE

< PERIODIC MAINTENANCE >

## BRAKE FLUID LEVEL AND LEAKS : Inspection

INFOID:000000006504594

- If fluid level is extremely low, check brake system for leaks.

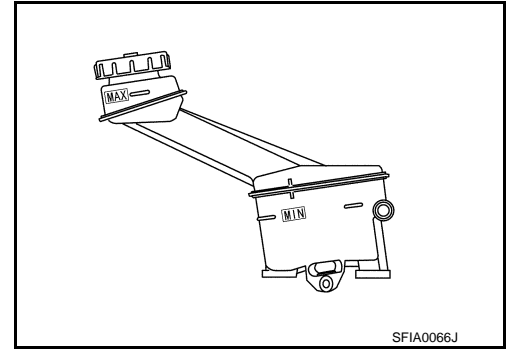

## BRAKE LINES AND CABLES

### BRAKE LINES AND CABLES : Inspection

INFOID:000000006504595

- Check brake fluid lines and parking brake cables for improper attachment, leaks, chafing, abrasions, deterioration, etc.

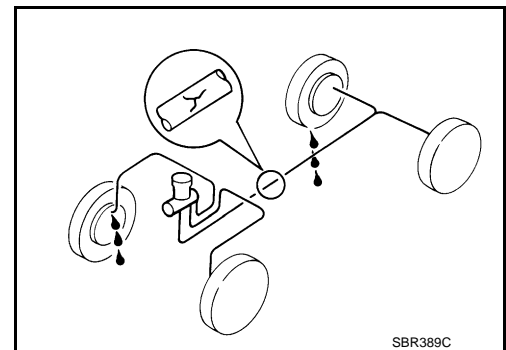

## BRAKE FLUID

### BRAKE FLUID : Changing

INFOID:000000006504596

1. Drain brake fluid from each bleed valve.
  2. Refill until new brake fluid comes out from each bleed valve. Use same procedure as in bleeding hydraulic system to refill brake fluid.  
Refer to [BR-10. "Refilling"](#).
    - Refill with recommended brake fluid.  
Refer to [MA-10. "Fluids and Lubricants"](#).
- Never reuse drained brake fluid.
  - Be careful not to splash brake fluid on painted areas.

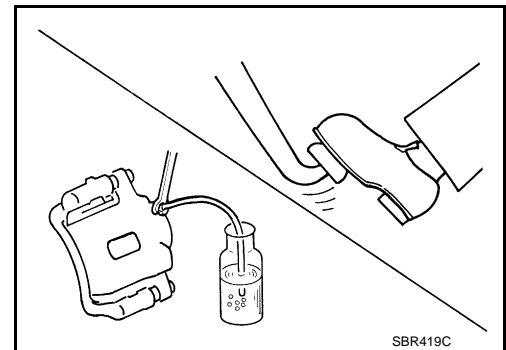

## DISC BRAKE

### DISC BRAKE : Inspection

INFOID:000000006504597

#### DISC ROTOR

Check condition, wear, and damage.

#### CALIPER



# CHASSIS MAINTENANCE

## < PERIODIC MAINTENANCE >

- Check for leakage.

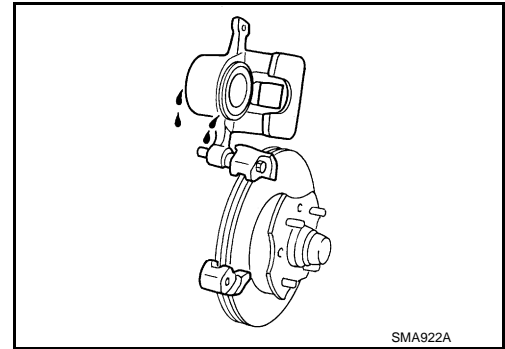

### BRAKE PAD

- Check for wear or damage.

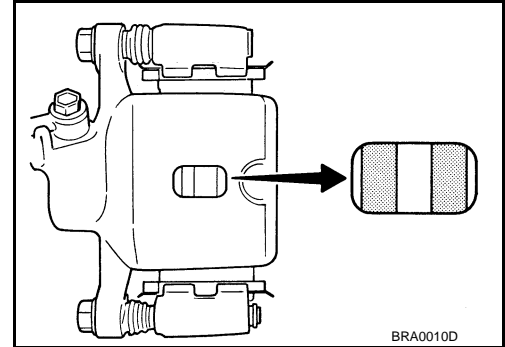

### DISC BRAKE : Front Disc Brake

INFOID:000000006504598

Unit: mm (in)

Item		Limit
Brake pad	Wear thickness	2.0 (0.079)
	Wear thickness	22.0 (0.866)
Disc rotor	Thickness variation (measured at 8 positions)	0.015 (0.0006)
	Runout (with it attached to the vehicle)	0.035 (0.0014)

### DRUM BRAKE

#### DRUM BRAKE : Inspection

INFOID:000000006504599

#### DRUM

Check condition, wear, and damage.

#### WHEEL CYLINDER

- Check for leakage.

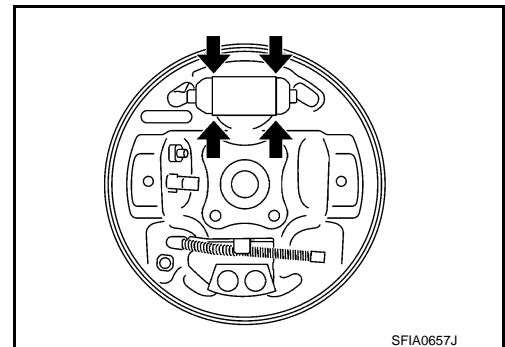

#### LINING

A  
B  
C  
D  
E  
F  
G  
H  
I  
J  
K  
L  
M  
N  
O  
MA

# CHASSIS MAINTENANCE

## < PERIODIC MAINTENANCE >

- Check for lining thickness.

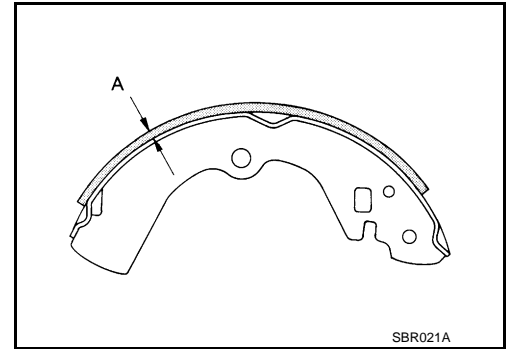

## DRUM BRAKE : Rear Drum Brake

INFOID:000000006504600

Unit: mm (in)

Item		Limit
Brake lining	Wear thickness	1.5 (0.059)
Brake drum	Wear inner diameter	230.0 (9.06)

## STEERING GEAR AND LINKAGE

### STEERING GEAR AND LINKAGE : Inspection

INFOID:000000006504601

#### STEERING GEAR

- Check gear housing and boots for looseness, damage and grease leakage.
- Check connection with steering column for looseness.

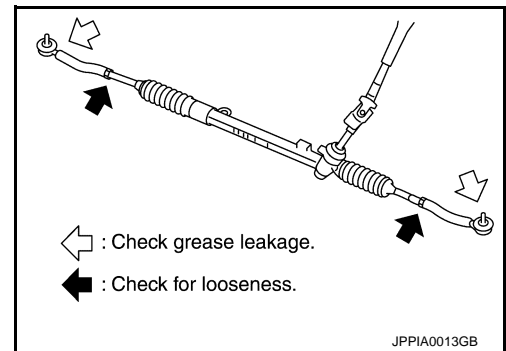

#### STEERING LINKAGE

Check ball joint, dust cover and other component parts for looseness, wear, damage and grease leakage.

## AXLE AND SUSPENSION PARTS

### AXLE AND SUSPENSION PARTS : Inspection

INFOID:000000006504602

Check front and rear axle and suspension parts for excessive play, cracks, wear or other damage.

- Shake each wheel to check for excessive play.
- Check wheel bearings for smooth operation.
- Check axle and suspension nuts and bolts for looseness.
- Check strut (shock absorber) for oil leakage or other damage.
- Check suspension ball joint for grease leakage and ball joint dust cover for cracks or other damage.

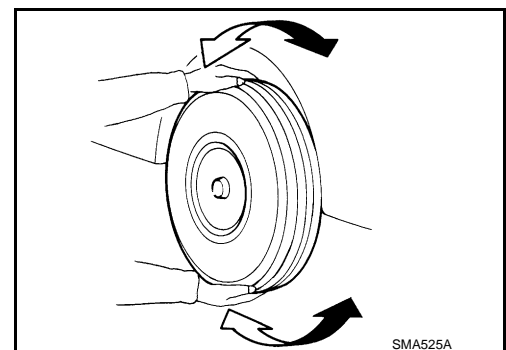

# CHASSIS MAINTENANCE

< PERIODIC MAINTENANCE >

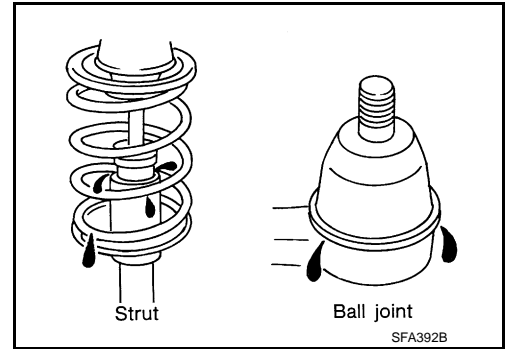

## DRIVE SHAFT

### DRIVE SHAFT : Inspection

- Check boot and drive shaft for cracks, wear, damage and grease leakage.

INFOID:000000006504603

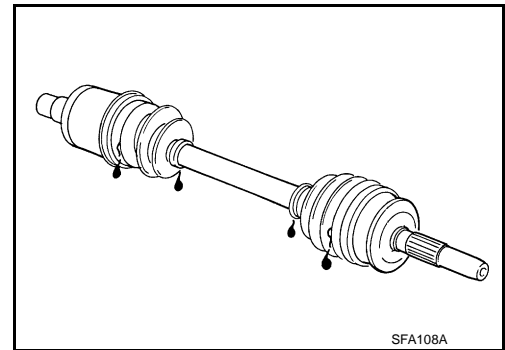

A  
B  
C  
D  
E  
F  
G  
H  
I  
J  
K  
L  
M  
N  
O

MA

# BODY MAINTENANCE

< PERIODIC MAINTENANCE >

## BODY MAINTENANCE

### LOCKS, HINGES AND HOOD LATCH

#### LOCKS, HINGES AND HOOD LATCH : Lubricating

INFOID:000000006504604

For hood and hood lock illustration.

- Hood: Refer to [DLK-173, "HOOD ASSEMBLY : Exploded View"](#). (WITH INTELLIGENT KEY SYSTEM)
- Hood: Refer to [DLK-320, "HOOD ASSEMBLY : Exploded View"](#). (WITHOUT INTELLIGENT KEY SYSTEM)
- Hood lock control: Refer to [DLK-201, "Exploded View"](#). (WITH INTELLIGENT KEY SYSTEM)
- Hood lock control: Refer to [DLK-348, "Exploded View"](#). (WITHOUT INTELLIGENT KEY SYSTEM)

For door and door lock illustration.

- Front door: Refer to [DLK-182, "DOOR ASSEMBLY : Exploded View"](#). (WITH INTELLIGENT KEY SYSTEM)
- Front door: Refer to [DLK-329, "DOOR ASSEMBLY : Exploded View"](#). (WITHOUT INTELLIGENT KEY SYSTEM)
- Front door lock: Refer to [DLK-203, "DOOR LOCK : Exploded View"](#). (WITH INTELLIGENT KEY SYSTEM)
- Front door lock: Refer to [DLK-350, "DOOR LOCK : Exploded View"](#). (WITHOUT INTELLIGENT KEY SYSTEM)
- Rear door: Refer to [DLK-187, "DOOR ASSEMBLY : Exploded View"](#). (WITH INTELLIGENT KEY SYSTEM)
- Rear door: Refer to [DLK-334, "DOOR ASSEMBLY : Exploded View"](#). (WITHOUT INTELLIGENT KEY SYSTEM)
- Rear door lock: Refer to [DLK-207, "DOOR LOCK : Exploded View"](#). (WITH INTELLIGENT KEY SYSTEM)
- Rear door lock: Refer to [DLK-354, "DOOR LOCK : Exploded View"](#). (WITHOUT INTELLIGENT KEY SYSTEM)

For back door and back door lock illustration.

- Back door: Refer to [DLK-192, "BACK DOOR ASSEMBLY : Exploded View"](#). (WITH INTELLIGENT KEY SYSTEM)
- Back door: Refer to [DLK-339, "BACK DOOR ASSEMBLY : Exploded View"](#). (WITHOUT INTELLIGENT KEY SYSTEM)
- Back door lock: Refer to [DLK-211, "DOOR LOCK : Exploded View"](#). (WITH INTELLIGENT KEY SYSTEM)
- Back door lock: Refer to [DLK-358, "DOOR LOCK : Exploded View"](#). (WITHOUT INTELLIGENT KEY SYSTEM)

### SEAT BELT, BUCKLES, RETRACTORS, ANCHORS AND ADJUSTERS

#### SEAT BELT, BUCKLES, RETRACTORS, ANCHORS AND ADJUSTERS : Inspection

INFOID:000000006504605

For front seat belt illustration. Refer to [SB-6, "SEAT BELT RETRACTOR : Exploded View"](#).

For rear seat belt illustration. Refer to [SB-11, "SEAT BELT RETRACTOR : Exploded View"](#).

#### **CAUTION:**

- **After any collision, inspect all seat belt assemblies, including retractors and other attached hardware (i.e. anchor bolt, guide rail set). Nissan recommends to replace all seat belt assemblies in use during a collision, unless not damaged and properly operating after minor collision. Also inspect seat belt assemblies not in use during a collision, and replace if damaged or improperly operating.**  
**Seat belt pre-tensioner should be replaced even if the seat belts are not in use during a frontal collision where the driver and passenger air bags are deployed.**
- **If any component of seat belt assembly is questionable, do not repair.**  
**Replace as seat belt assembly.**
- **If webbing is cut, frayed, or damaged, replace belt assembly.**
- **Never oil tongue and buckle.**
- **Use a genuine NISSAN seat belt assembly.**

For details, refer to [SB-4, "SEAT BELT RETRACTOR : Inspection"](#) , [SB-9, "SEAT BELT RETRACTOR : Inspection"](#) in SB section.

- Check anchors for loose mounting
- Check belts for damage
- Check retractor for smooth operation
- Check function of buckles and tongues when buckled and released

# SERVICE DATA AND SPECIFICATIONS (SDS)

< SERVICE DATA AND SPECIFICATIONS (SDS)

## SERVICE DATA AND SPECIFICATIONS (SDS)

### SERVICE DATA AND SPECIFICATIONS (SDS)

#### DRIVE BELT

DRIVE BELT : Drive Belt

INFOID:0000000006504606

#### DRIVE BELT

Tension of drive belt	Belt tension is not necessary, as it is automatically adjusted by drive belt auto-tensioner.
-----------------------	--

### ENGINE COOLANT

ENGINE COOLANT : Periodical Maintenance Specification

INFOID:0000000006504607

#### ENGINE COOLANT CAPACITY (APPROXIMATE)

Unit: ℓ (US qt, Imp qt)

Engine coolant capacity (With reservoir tank at "MAX" level)	CVT models	7.1 (7-1/2, 6-1/4)
	M/T models	6.8 (7-1/4, 6)
Reservoir tank engine coolant capacity (At "MAX" level)		0.7 (3/4, 5/8)

### ENGINE OIL

ENGINE OIL : Periodical Maintenance Specification

INFOID:0000000006504608

#### ENGINE OIL CAPACITY (APPROXIMATE)

Unit: ℓ (US qt, Imp qt)

Drain and refill	With oil filter change	4.1 (4-3/8, 3-5/8)
	Without oil filter change	3.8 (4, 3-3/8)
Dry engine (Overhaul)		4.9 (5-1/8, 4-3/8)

### SPARK PLUG

SPARK PLUG : Spark Plug

INFOID:0000000006504609

#### SPARK PLUG

Unit: mm (in)

Make	DENSO	
Standard type	FXE20HR11	
Gap (Nominal)	Standard	1.1 (0.043)
	Limit	1.4 (0.055)

### ROAD WHEEL

ROAD WHEEL : Road Wheel

INFOID:0000000006504610

#### ALUMINUM WHEEL

Item		Limit
Radial runout	Lateral deflection	Less than 0.3 mm (0.012 in)
	Vertical deflection	
Allowable unbalance	Dynamic (At flange)	Less than 10 g (0.35 oz) (one side)
	Static (At flange)	Less than 20 g (0.70 oz)

### STEEL WHEEL

A  
B  
C  
D  
E  
F  
G  
H  
I  
J  
K  
L  
M  
N  
O

MA

## SERVICE DATA AND SPECIFICATIONS (SDS)

### < SERVICE DATA AND SPECIFICATIONS (SDS)

Item		Limit	
Radial runout	Conventional	Lateral deflection	Less than 0.8 mm (0.031 in)
		Vertical deflection	Less than 0.5 mm (0.020 in)
	Emergency	Lateral deflection	Less than 1.2 mm (0.031 in)
		Vertical deflection	Less than 1.0 mm (0.020 in)
Allowable unbalance		Dynamic (At flange)	Less than 10 g (0.35 oz) (one side)
		Static (At flange)	Less than 20 g (0.70 oz)