

A
STR
C
D
E
F
G
H
I
J
K
L
M
N
O
P

SECTION STR

STARTING SYSTEM

CONTENTS

<p>BASIC INSPECTION 2</p> <p>DIAGNOSIS AND REPAIR WORKFLOW 2</p> <p style="padding-left: 20px;">Work Flow2</p> <p>SYSTEM DESCRIPTION 5</p> <p>STARTING SYSTEM 5</p> <p>M/T5</p> <p style="padding-left: 20px;">M/T : System Diagram5</p> <p style="padding-left: 20px;">M/T : System Description5</p> <p style="padding-left: 20px;">M/T : Component Parts Location6</p> <p style="padding-left: 20px;">M/T : Component Description6</p> <p>CVT6</p> <p style="padding-left: 20px;">CVT : System Diagram (With Intelligent Key)7</p> <p style="padding-left: 20px;">CVT : System Diagram (Without Intelligent Key)7</p> <p style="padding-left: 20px;">CVT : System Description (With Intelligent Key)7</p> <p style="padding-left: 20px;">CVT : System Description (Without Intelligent Key)8</p> <p style="padding-left: 20px;">CVT : Component Parts Location8</p> <p style="padding-left: 20px;">CVT : Component Description (With Intelligent Key)8</p> <p style="padding-left: 20px;">CVT : Component Description (Without Intelligent Key)9</p> <p>DTC/CIRCUIT DIAGNOSIS10</p> <p>B TERMINAL CIRCUIT10</p> <p style="padding-left: 20px;">Description 10</p> <p style="padding-left: 20px;">Diagnosis Procedure 10</p> <p>S CONNECTOR CIRCUIT11</p> <p style="padding-left: 20px;">Description 11</p> <p style="padding-left: 20px;">Diagnosis Procedure 11</p>	<p>STARTING SYSTEM12</p> <p style="padding-left: 20px;">Wiring Diagram - STARTING SYSTEM (WITH INTELLIGENT KEY) -12</p> <p style="padding-left: 20px;">Wiring Diagram - STARTING SYSTEM (WITHOUT INTELLIGENTKEY) -16</p> <p>SYMPTOM DIAGNOSIS20</p> <p>STARTING SYSTEM20</p> <p style="padding-left: 20px;">Symptom Table20</p> <p>PRECAUTION21</p> <p>PRECAUTIONS21</p> <p style="padding-left: 20px;">Precaution for Supplemental Restraint System (SRS) "AIR BAG" and "SEAT BELT PRE-TENSIONER"21</p> <p>PREPARATION22</p> <p>PREPARATION22</p> <p style="padding-left: 20px;">Special Service Tools22</p> <p style="padding-left: 20px;">Commercial Service Tools22</p> <p>REMOVAL AND INSTALLATION23</p> <p>STARTER MOTOR23</p> <p style="padding-left: 20px;">Exploded View23</p> <p style="padding-left: 20px;">Removal and Installation25</p> <p style="padding-left: 20px;">Inspection26</p> <p>SERVICE DATA AND SPECIFICATIONS (SDS)27</p> <p>SERVICE DATA AND SPECIFICATIONS (SDS)27</p> <p style="padding-left: 20px;">Starter Motor27</p>
---	---

DIAGNOSIS AND REPAIR WORKFLOW

< BASIC INSPECTION >

BASIC INSPECTION

DIAGNOSIS AND REPAIR WORKFLOW

Work Flow

INFOID:000000006502699

OVERALL SEQUENCE

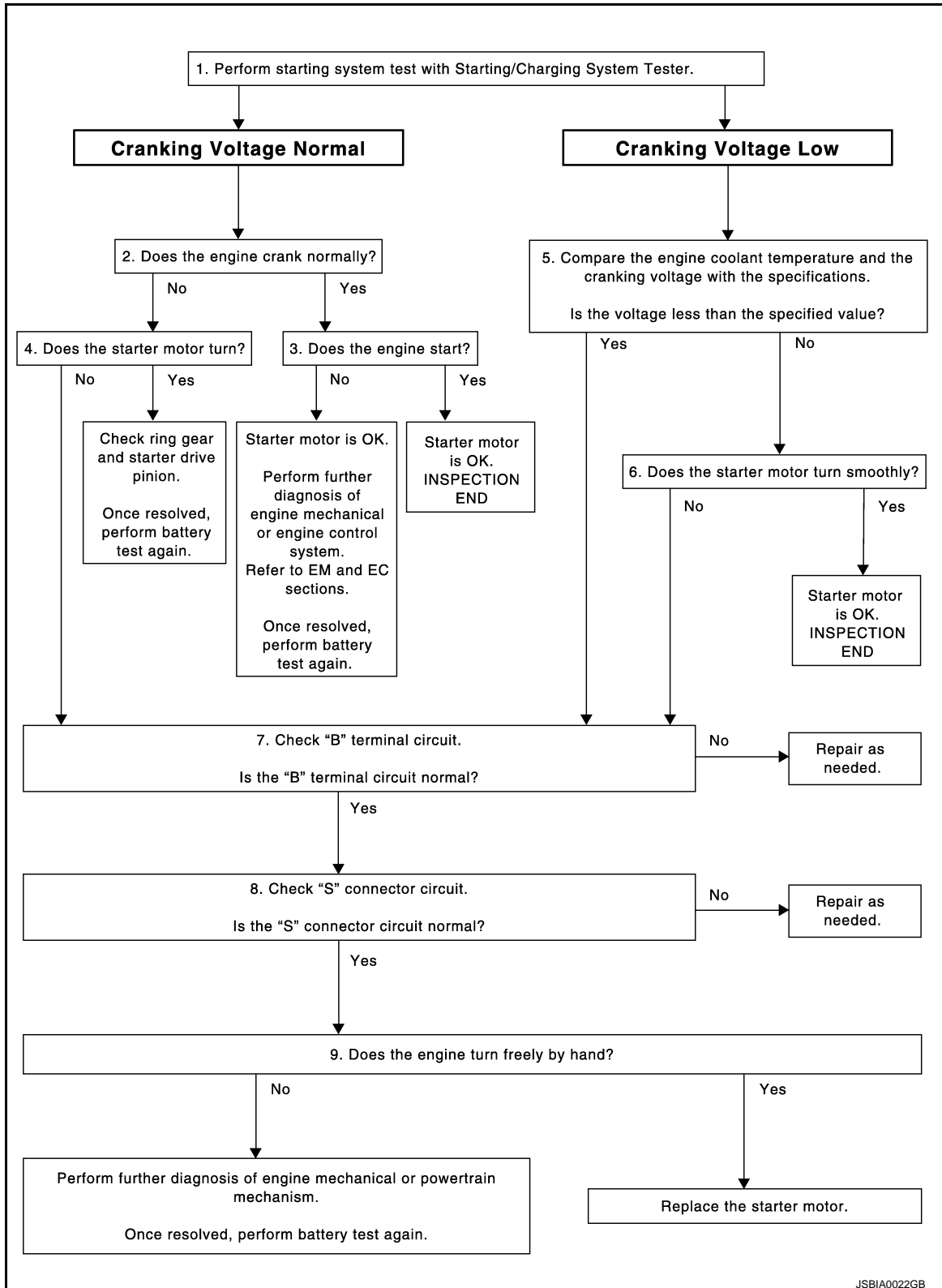

JSBIA0022GB

DETAILED FLOW

DIAGNOSIS AND REPAIR WORKFLOW

< BASIC INSPECTION >

NOTE:

To ensure a complete and thorough diagnosis, the battery, starter motor and alternator test segments must be done as a set from start to finish.

1. DIAGNOSIS WITH STARTING/CHARGING SYSTEM TESTER

Perform the starting system test with Starting/Charging System Tester (SST: J-44373). For details and operating instructions, refer to Technical Service Bulletin.

Test result

CRANKING VOLTAGE NORMAL>>GO TO 2.

CRANKING VOLTAGE LOW>>GO TO 5.

CHARGE BATTERY>>Perform the slow battery charging procedure. (Initial rate of charge is 10A for 12 hours.) Perform battery test again. Refer to Technical Service Bulletin.

REPLACE BATTERY>>Before replacing battery, clean the battery cable clamps and battery posts. Perform battery test again. Refer to Technical Service Bulletin. If second test result is "REPLACE BATTERY", then do so. Perform battery test again to confirm repair.

2. CRANKING CHECK

Check that the starter motor operates correctly.

Does the engine crank normally?

YES >> GO TO 3.

NO >> GO TO 4.

3. ENGINE START CHECK

Check that the engine starts.

Does the engine start?

YES >> Starter motor is OK. INSPECTION END

NO >> Starter motor is OK. Perform further diagnosis of engine mechanical or engine control system. Refer EM and EC sections. Once resolved, perform battery test again.

4. STARTER MOTOR ACTIVATION

Check that the starter motor operates.

Does the starter motor turn?

YES >> Check ring gear and starter motor drive pinion. Once resolved, perform battery test again.

NO >> GO TO 7.

5. COMPARISON BETWEEN ENGINE COOLANT AND CRANKING VOLTAGE

Compare the engine coolant temperature and the cranking voltage with the specifications.

Minimum Specification of Cranking Voltage Referencing Coolant Temperature

Engine coolant temperature [°C (°F)]	Voltage [V]
-30 to -20 (-22 to -4)	8.6
-19 to -10 (-2 to 14)	9.1
-9 to 0 (16 to 32)	9.5
More than 1 (More than 34)	9.9

Is the voltage less than the specified value?

YES >> GO TO 7.

NO >> GO TO 6.

6. STARTER OPERATION

Check the starter operation status.

Does the starter motor turn smoothly?

YES >> Starter motor is OK. INSPECTION END

NO >> GO TO 7.

7. "B" TERMINAL CIRCUIT INSPECTION

Check "B" terminal circuit. Refer to [STR-10, "Diagnosis Procedure"](#).

Is "B" terminal circuit normal?

STR

C

D

E

F

G

H

I

J

K

L

M

N

O

P

DIAGNOSIS AND REPAIR WORKFLOW

< BASIC INSPECTION >

- YES >> GO TO 8.
- NO >> Repair as needed.

8. "S" CONNECTOR CIRCUIT INSPECTION

Check "S" connector circuit. Refer to [STR-11, "Diagnosis Procedure"](#).

Is "S" connector circuit normal?

- YES >> GO TO 9.
- NO >> Repair as needed.

9. ENGINE ROTATION STATUS

Check that the engine can be rotated by hand.

Does the engine turn freely by hand?

- YES >> Replace starter motor.
- NO >> Perform further diagnosis of engine mechanical or powertrain mechanism. Once resolved, perform battery test again. Refer to Technical Service Bulletin.

STARTING SYSTEM

< SYSTEM DESCRIPTION >

SYSTEM DESCRIPTION

STARTING SYSTEM

M/T

M/T : System Diagram

INFOID:0000000006502700

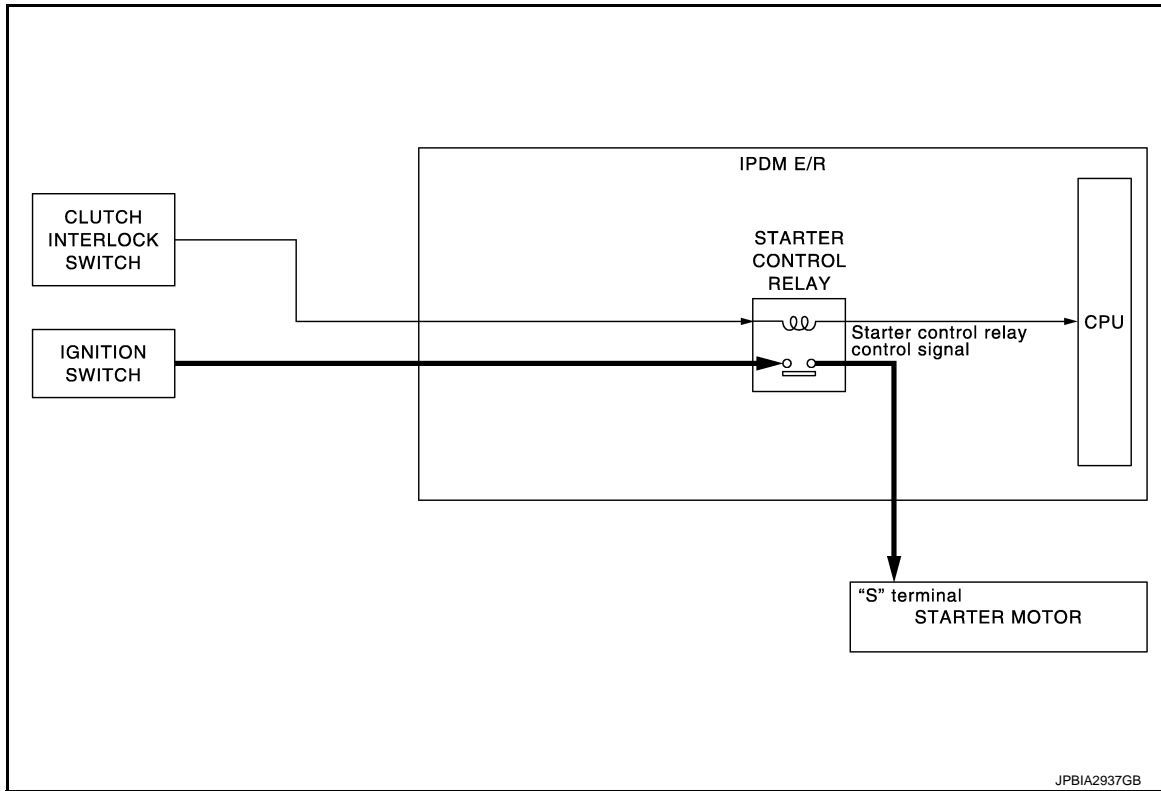

M/T : System Description

INFOID:0000000006502701

- When the clutch interlock switch is turned ON, power is supplied to starter control relay. And IPDM E/R (CPU) detect clutch interlock switch condition by the inputted signal.
- When starter operating condition is satisfied, IPDM E/R turns starter control relay ON by starter control relay control signal.
- When engine cranking condition is satisfied, then battery power is supplied to starter motor ("S" terminal) through starter control relay.

STARTING SYSTEM

< SYSTEM DESCRIPTION >

M/T : Component Parts Location

INFOID:000000006502702

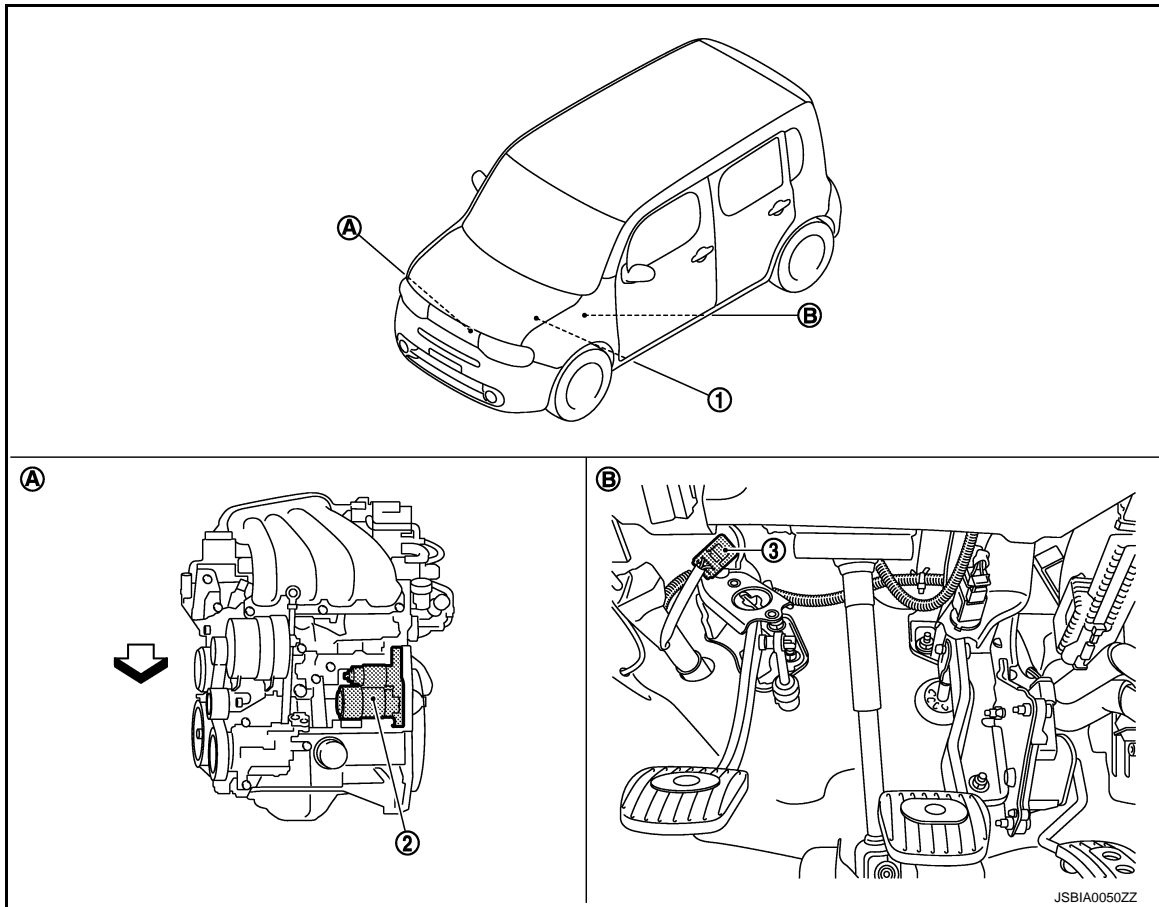

- 1. IPDM E/R
Refer to [PCS-6, "Component Parts Location"](#). (WITH I-KEY)
Refer to [PCS-36, "Component Parts Location"](#). (WITHOUT I-KEY)
- 2. Starter motor
- 3. Clutch interlock switch

A. Engine B. Clutch pedal

↙ :Vehicle front

M/T : Component Description

INFOID:000000006502703

Component part	Description
Clutch interlock switch	The switch turns ON and electric power is supplied to the starter control relay inside IPDM E/R when the clutch pedal is depressed.
IPDM E/R	CPU inside IPDM E/R controls the starter control relay.
Starter motor	The starter motor plunger closes and the motor is supplied with battery power, which in turn cranks the engine, when the "S" terminal is supplied with electric power.

CVT

STARTING SYSTEM

< SYSTEM DESCRIPTION >

CVT : System Diagram (With Intelligent Key)

INFOID:0000000006502704

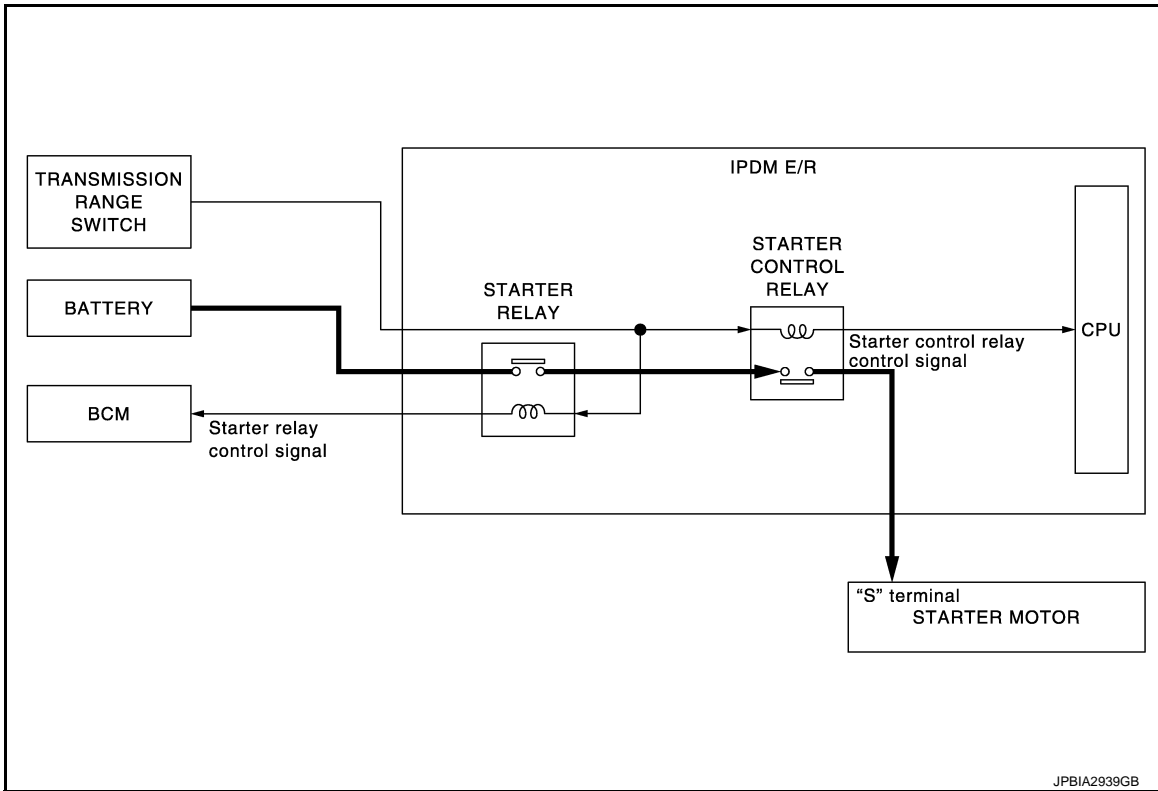

JPBIA2939GB

CVT : System Diagram (Without Intelligent Key)

INFOID:0000000006502705

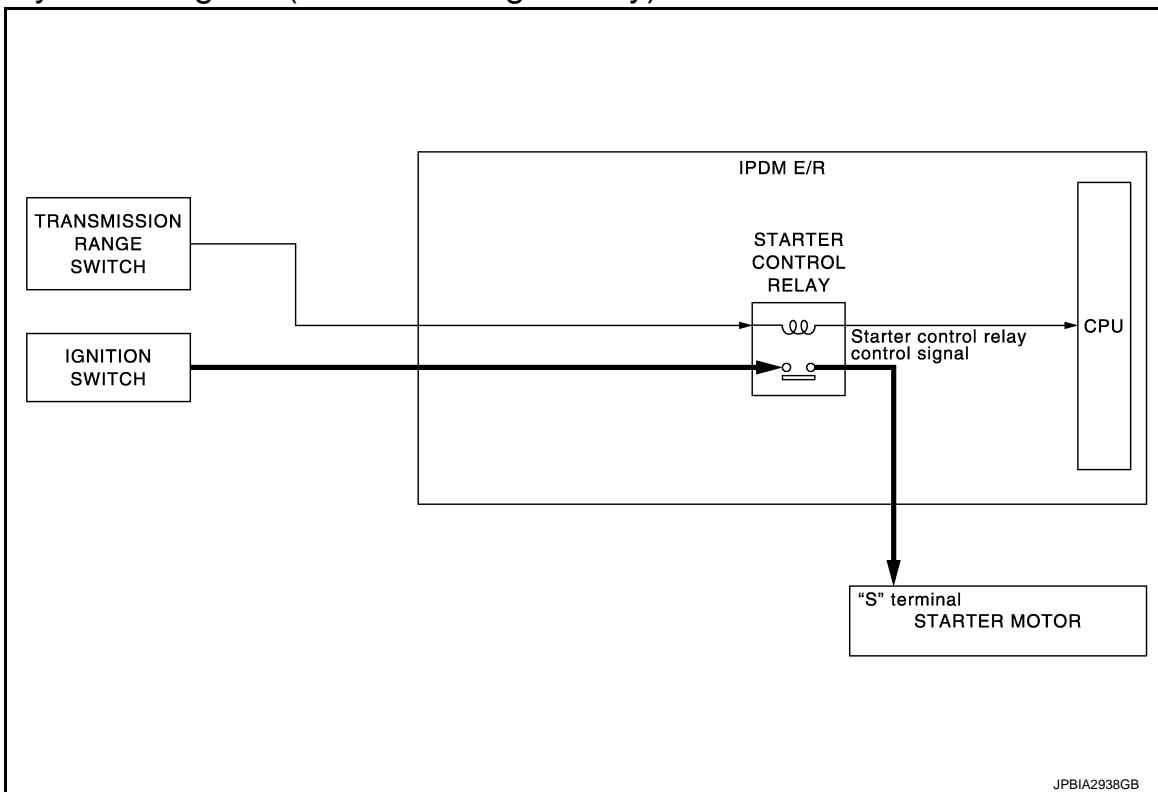

JPBIA2938GB

CVT : System Description (With Intelligent Key)

INFOID:0000000006502706

- When selector lever is P or N, power is supplied to starter relay and starter control relay by Transmission range switch. And BCM and IPDM E/R (CPU) detect selector lever P/N condition by the inputted signal.

STARTING SYSTEM

< SYSTEM DESCRIPTION >

- When starter operating condition is satisfied, IPDM E/R turns starter control relay ON by starter control relay control signal.
- When engine cranking condition is satisfied, BCM turns starter relay ON by starter control relay control signal.
- Then battery power is supplied to starter motor ("S" terminal) through starter control relay and starter relay.

CVT : System Description (Without Intelligent Key)

INFOID:000000006502707

- When selector lever is P or N, power is supplied to starter control relay by Transmission range switch. And IPDM E/R (CPU) detect selector lever P/N condition by the inputted signal.
- When engine cranking condition is satisfied, then battery power is supplied to starter motor ("S" terminal) through starter control relay.

CVT : Component Parts Location

INFOID:000000006502708

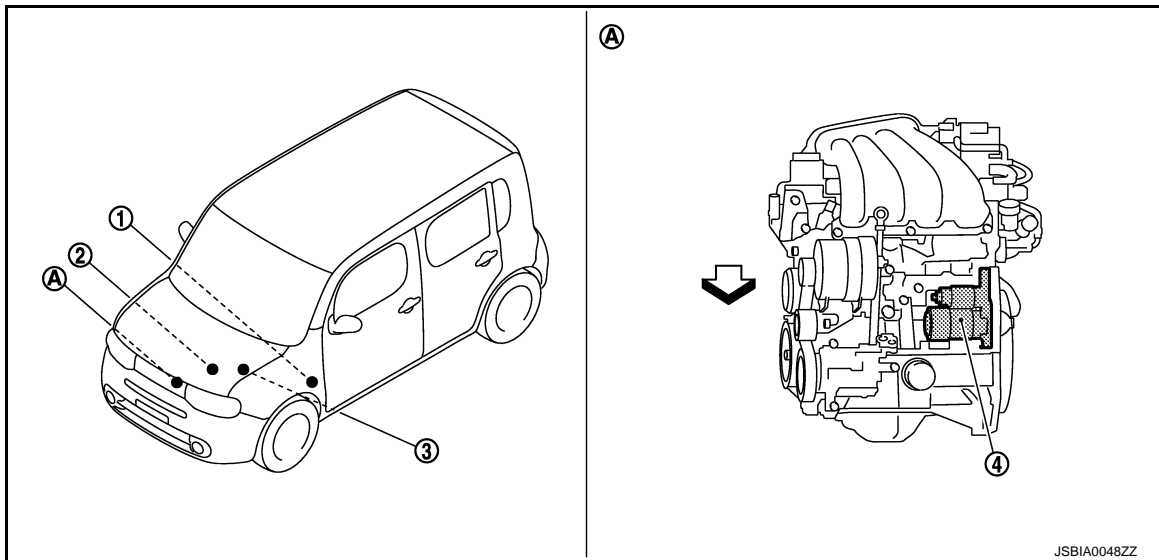

1. BCM (Without Intelligent Key)
Refer to [BCS-84, "Component Parts Location"](#).
 2. Transmission range switch
Refer to [TM-69, "Component Parts Location"](#).
 3. IPDM E/R
Refer to [PCS-6, "Component Parts Location"](#). (With I Key)
Refer to [PCS-36, "Component Parts Location"](#). (Without I Key)
 4. Starter motor
- A. Engine
↙ :Vehicle front

CVT : Component Description (With Intelligent Key)

INFOID:000000006502709

Component part	Description
Transmission range switch	Transmission range switch supplies power to the starter relay and starter control relay inside IPDM E/R when the selector lever is shifted to the P or N position.
BCM	BCM controls the starter relay inside IPDM E/R.
IPDM E/R	CPU inside IPDM E/R controls the starter control relay.
Starter motor	The starter motor plunger closes and the motor is supplied with battery power, which in turn cranks the engine, when the "S" terminal is supplied with electric power.

STARTING SYSTEM

< SYSTEM DESCRIPTION >

CVT : Component Description (Without Intelligent Key)

INFOID:000000006502710

A

Component part	Description
Transmission range switch	Transmission range switch supplies power to the starter relay inside IPDM E/R when the selector lever is shifted to the P or N position.
IPDM E/R	CPU inside IPDM E/R controls the starter control relay.
Starter motor	The starter motor plunger closes and the motor is supplied with battery power, which in turn cranks the engine, when the "S" terminal is supplied with electric power.

STR

C

D

E

F

G

H

I

J

K

L

M

N

O

P

B TERMINAL CIRCUIT

< DTC/CIRCUIT DIAGNOSIS >

DTC/CIRCUIT DIAGNOSIS

B TERMINAL CIRCUIT

Description

INFOID:000000006502711

The "B" terminal is constantly supplied with battery power.

Diagnosis Procedure

INFOID:000000006502712

CAUTION:

Perform diagnosis under the condition that engine cannot start by the following procedure.

1. Remove fuel pump fuse.
2. Crank or start the engine (where possible) until the fuel pressure is released.

1. CHECK "B" TERMINAL CIRCUIT

1. Turn ignition switch OFF.
2. Check that starter motor "B" terminal connection is clean and tight.
3. Check voltage between starter motor "B" terminal and ground.

Terminals			Voltage (Approx.)
(+)	(-)		
Starter motor "B" terminal	Terminal		Battery voltage
F11	2		
		Ground	

Is the inspection result normal?

YES >> GO TO 2.

NO >> Check harness between battery and starter motor for open circuit.

2. CHECK BATTERY CABLE CONNECTION STATUS (VOLTAGE DROP TEST)

1. Shift CVT selector lever to "P" or "N" position. (CVT models)
Keep depressing clutch pedal fully. (M/T models)
2. Check voltage between battery positive terminal and starter motor "B" terminal.

Terminals			Condition	Voltage (Approx.)
(+)	(-)			
	Starter motor "B" terminal	Terminal	When the ignition switch is in START position	Less than 0.5 V
Battery positive terminal	F11	2		

Is the inspection result normal?

YES >> GO TO 3.

NO >> Check harness between the battery and the starter motor for poor continuity.

3. CHECK GROUND CIRCUIT STATUS (VOLTAGE DROP TEST)

1. Shift CVT selector lever to "P" or "N" position. (CVT models)
Keep depressing clutch pedal fully. (M/T models)
2. Check voltage between starter motor case and battery negative terminal.

Terminals		Condition	Voltage (Approx.)
(+)	(-)		
Starter motor case	Battery negative terminal	When the ignition switch is in START position	Less than 0.2 V

Is the inspection result normal?

YES >> "B" terminal circuit is OK. Further inspection is necessary. Refer to [STR-2, "Work Flow"](#).

NO >> Check the starter motor case and ground for poor continuity.

S CONNECTOR CIRCUIT

< DTC/CIRCUIT DIAGNOSIS >

S CONNECTOR CIRCUIT

Description

INFOID:000000006502713

The starter motor magnetic switch is supplied with power when the ignition switch is turned to the START position while the selector lever is in the P or N position for CVT models or the clutch pedal is depressed for M/T models.

A

STR

Diagnosis Procedure

INFOID:000000006502714

CAUTION:

Perform diagnosis under the condition that engine cannot start by the following procedure.

1. Remove fuel pump fuse.
2. Crank or start the engine (where possible) until the fuel pressure is released.

1. CHECK "S" CONNECTOR CIRCUIT

1. Turn ignition switch OFF.
2. Disconnect starter motor connector.
3. Shift CVT selector lever to "P" or "N" position. (CVT models)
Keep depressing clutch pedal fully. (M/T models)
4. Check voltage between starter motor harness connector and ground.

Terminals		(-)	Condition	Voltage (Approx.)
(+)	Terminal			
Starter motor harness connector				
F10	1	Ground	When the ignition switch is in START position	Battery voltage

Is the inspection result normal?

YES >> "S" connector circuit is OK. Further inspection is necessary. Refer to [STR-2, "Work Flow"](#).

NO >> GO TO 2.

2. CHECK HARNESS CONTINUITY (OPEN CIRCUIT)

1. Disconnect IPDM E/R connector.
2. Check continuity between starter motor harness connector and IPDM E/R harness connector.

Starter motor harness connector		IPDM E/R harness connector		Continuity
Connector No.	Terminal No.	Connector No.	Terminal No.	
F10	1	E10	3	Existed

Is the inspection result normal?

YES >> Further inspection is necessary. Refer to [STR-2, "Work Flow"](#).

NO >> Repair the harness.

C

D

E

F

G

H

I

J

K

L

M

N

O

P

STARTING SYSTEM

< DTC/CIRCUIT DIAGNOSIS >

STARTING SYSTEM

Wiring Diagram - STARTING SYSTEM (WITH INTELLIGENT KEY) -

INFOID:000000006502715

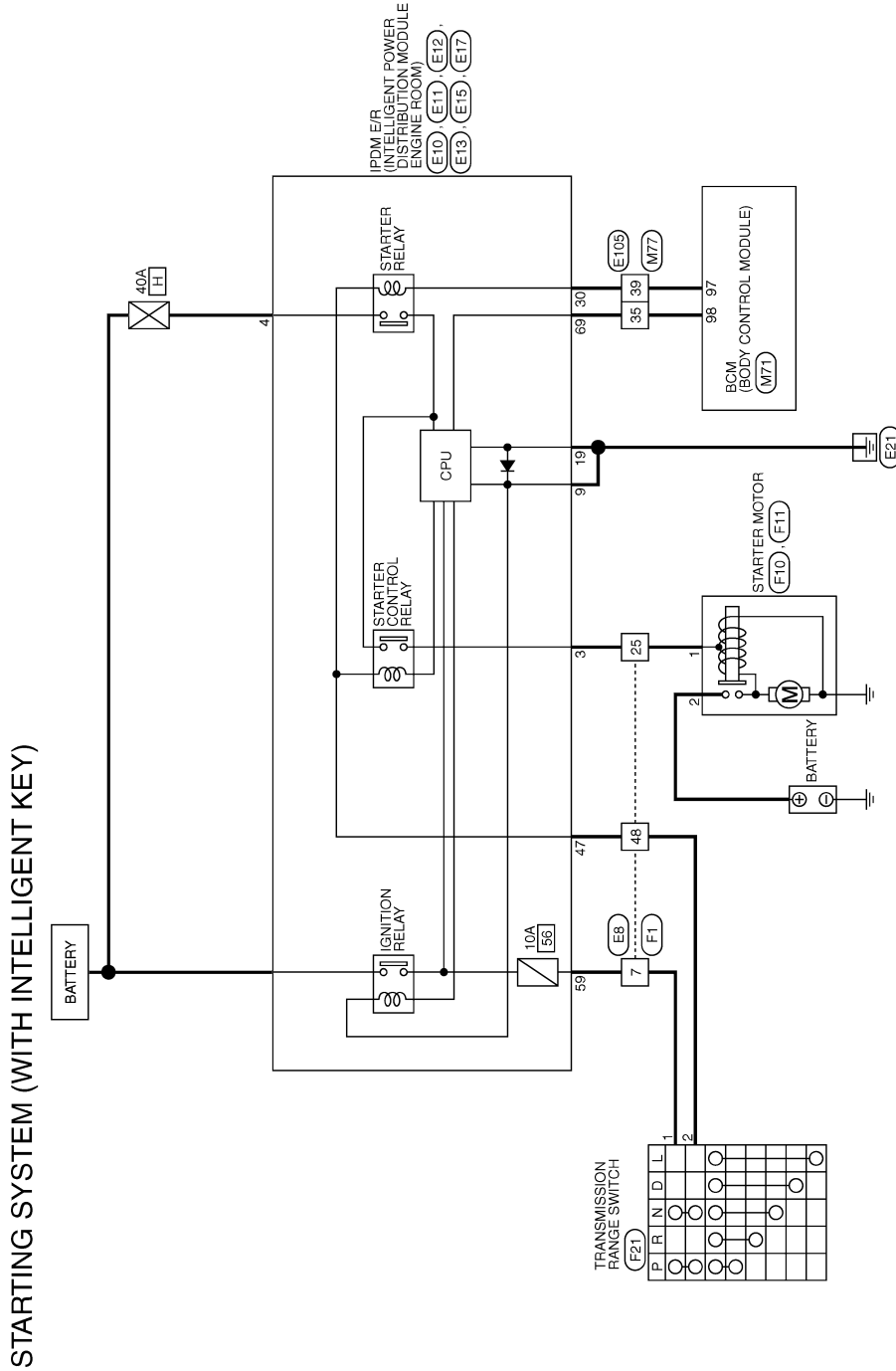

2009/02/27

JCBWM1301GB

STARTING SYSTEM

< DTC/CIRCUIT DIAGNOSIS >

STARTING SYSTEM (WITH INTELLIGENT KEY)

Connector No.	EB
Connector Name	WIRE TO WIRE
Connector Type	SA33MB-RS (0-SJ22)

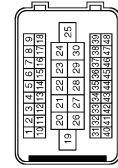

Terminal No.	43	R	-- [With CVT]
	43	LG	-- [With M/T]
	44	R	--
	46	W	--
	47	G	--
	48	BR	--

Connector No.	E10
Connector Name	IPM E/R INTELLIGENT POWER DISTRIBUTION MODULE (ENGINE ROOM)
Connector Type	MO8FW-LC



5	4	3
8	7	6

Terminal No.	Color of Wire	Signal Name [Specification]
3	BR	--
4	P	--
5	LG	--
6	SB	--
7	Y	--
8	V	--

Connector No.	E11
Connector Name	IPM E/R INTELLIGENT POWER DISTRIBUTION MODULE (ENGINE ROOM)
Connector Type	MO8FB-LC



11	10	9
14	13	12

Terminal No.	Color of Wire	Signal Name [Specification]
9	B/W	--
10	L	--
13	W	--

Connector No.	E12
Connector Name	IPM E/R INTELLIGENT POWER DISTRIBUTION MODULE (ENGINE ROOM)
Connector Type	MS08FB-R-CS



17	16	15
22	21	20
19	18	18

Terminal No.	Color of Wire	Signal Name [Specification]
18	Y	--
19	B/W	--
21	W	--
22	V	--

Connector No.	E13
Connector Name	IPM E/R INTELLIGENT POWER DISTRIBUTION MODULE (ENGINE ROOM)
Connector Type	TH12FW-NH



29	27	26	25	24	23
34	33	32	31	30	29

Terminal No.	Color of Wire	Signal Name [Specification]
24	LG	--
25	Y	--
26	P	--
27	L	--
28	P	--
30	SB	--
31	W	--
33	O	--
34	R	--

Connector No.	E15
Connector Name	IPM E/R INTELLIGENT POWER DISTRIBUTION MODULE (ENGINE ROOM)
Connector Type	NS38FW-CS



53	52	51	50
62	61	60	59
58	57	56	55
49	48	47	47

Terminal No.	Color of Wire	Signal Name [Specification]
47	BR	--
49	W	--
50	GR	--
51	R	--
52	P	--
54	GR	--
55	P	--
56	SB	--
57	G	--
58	R	-- [With CVT]
58	Y	-- [With M/T]
59	Y	--
60	V	--
61	W	--
62	L	--

Connector No.	E17
Connector Name	IPM E/R INTELLIGENT POWER DISTRIBUTION MODULE (ENGINE ROOM)
Connector Type	TH10FB-NH



67	66	65	64	63
72	71	70	69	68

Terminal No.	Color of Wire	Signal Name [Specification]
64	R	--
66	L	--
69	Y	--

JCBWM2616GB

A
STR
C
D
E
F
G
H
I
J
K
L
M
N
O
P

STARTING SYSTEM

< DTC/CIRCUIT DIAGNOSIS >

STARTING SYSTEM (WITH INTELLIGENT KEY)

Connector No.	E105
Connector Name	WIRE TO WIRE
Connector Type	THB0MW-CS1E-TM4



Terminal No.	Color of Wire	Signal Name [Specification]
1	V	-
2	W	-
3	SB	-
4	G	-
5	P	- [With MAV]
6	L	- [Without MAV]
7	Y	-
8	O	-
9	W	-
10	SB	-
31	V	-
32	R	-
33	GR	-
34	P	-
35	Y	-
36	BR	-
39	SB	-
44	R	-
45	V	-
46	P	-
48	L	-
51	BR	- [With CVT]
51	B	- [With M/T]
53	SB	-
54	W	- [With CVT]
54	O	- [With M/T]
57	LG	-
59	L	-
60	O	-
61	G	-
62	W	-
63	L	-
67	GR	- [With CVT]
67	V	- [With M/T]
69	P	-
70	SHIELD	-
71	GR	-

72	LG	-
73	P	-
74	V	-
76	Y	-
77	LG	-
78	O	-
79	G	-
80	P	-
81	L	-
82	W	-
83	BR	-
84	B	-
87	GR	-
91	W	-
92	Y	-
93	Y	-
94	R	-
95	V	-
96	LG	-
97	R	-
98	SB	-
99	G	-
100	P	-

Connector No.	F1
Connector Name	WIRE TO WIRE
Connector Type	SAA39FB-RS10-SJ22

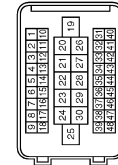

Terminal No.	Color of Wire	Signal Name [Specification]
1	SB	-
2	LG	-
3	R	-
4	Y	-
7	V	-
8	G	-
9	SB	-
10	L	-
11	Y	-
12	GR	-
13	BR	-
14	G	-
15	W	-

16	Y	-
17	P	-
18	BR	-
21	G	-
22	L	-
23	W	-
24	R	-
25	R	-
26	B	-
27	SB	-
28	V	-
29	V	-
30	BR	-
31	GR	-
32	BR	-
33	W	-
34	LG	-
35	V	-
36	Y	-
37	SB	- [For California]
37	W	- [Except for California]
39	G	-
40	P	-
41	O	-
42	G	-
43	R	-
44	P	-
46	GR	-
47	Y	-
48	BR	-

Connector No.	F10
Connector Name	STARTER MOTOR
Connector Type	-



Terminal No.	Color of Wire	Signal Name [Specification]
1	R	-

Connector No.	F11
Connector Name	STARTER MOTOR
Connector Type	-



Terminal No.	Color of Wire	Signal Name [Specification]
2	B/R	-

Connector No.	F21
Connector Name	TRANSMISSION RANGE SWITCH
Connector Type	RK08FG



Terminal No.	Color of Wire	Signal Name [Specification]
1	V	-
2	BR	-
3	R	-
4	GR	-
5	SB	-
6	W	-
7	Y	-
8	G	-

JCBWM2617GB

STARTING SYSTEM

< DTC/CIRCUIT DIAGNOSIS >

A

STR

C

D

E

F

G

H

I

J

K

L

M

N

O

P

STARTING SYSTEM (WITH INTELLIGENT KEY)

Connector No.	M71
Connector Name	BCM BODY CONTROL MODULE
Connector Type	TH4CFV-NH



Terminal No.	Color of Wire	Signal Name [Specification]
75	SB	DRIVER DOOR REQUEST SW
76	L/O	PUSH SW
78	LG	DRIVER DOOR ANT+
78	V	DRIVER DOOR ANT-
80	BR/Y	PASSENGER DOOR ANT+
81	L/Y	PASSENGER DOOR ANT-
82	W/B	BACK DOOR ANT+
83	B/W	BACK DOOR ANT-
84	Y/G	ROOM ANT+
85	Y/L	ROOM ANT-
86	P	LUGGAGE ROOM ANT+
87	L	LUGGAGE ROOM ANT-
90	W/L	PUSH-BUTTON IGNITION SW ILL POWER
91	Y	ACC/ON IND
92	BR/R	PUSH-BUTTON IGNITION SW ILL GND
93	GR/W	F-KEY WARN BUZZER
96	BR/W	ACC RELAY COIT
97	L/R	STARTER RELAY COIT
98	BR	IGN RELAY (PDM/E/R) COIT
98	W/R	IGN RELAY COIT
100	G	PASSENGER DOOR REQUEST SW
102	G	SHIFT N/P
104	Y/R	CVT SHIFT SELECTOR POWER SUPPLY
105	B/O	STOP LAMP SW Z
106	Y/B	BLOWER FAN MOTOR RELAY COIT

Connector No.	M77
Connector Name	WIRE TO WIRE
Connector Type	TH4CFV-CS16-TM4

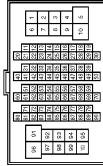

Terminal No.	Color of Wire	Signal Name [Specification]
1	B/O	
2	R	
3	G/R	
4	G/B	
5	L	
6	L	
7	W/R	
8	G/W	
9	Y/L	
10	W	
31	GR/L	
32	L/B	
33	R/Y	
34	SB	
35	BR	
36	G	
39	L/R	
44	G/O	
45	LG/R	
46	GR/W	
48	L/O	
51	B/W	
53	R/L	
54	O	
57	GR	
58	V	
60	R/W	
61	V/W	
62	W/L	
63	W/B	
67	Y/R	
68	LG	
70	SHIELD	
71	P/B	
72	R/G	
73	R	
74	L/Y	
76	W/G	

77	GR/R	--
78	O	--
78	LG	--
80	P	--
81	L	--
82	GR	--
83	G/R	--
84	B	--
87	G	--
91	R	--
92	O	--
93	Y	--
94	R/B	--
95	L/W	--
96	Y	--
97	L	--
98	BR/W	--
99	W	--
100	G/R	--

STARTING SYSTEM

< DTC/CIRCUIT DIAGNOSIS >

Wiring Diagram - STARTING SYSTEM (WITHOUT INTELLIGENTKEY) -

INFOID:000000006502716

STARTING SYSTEM (WITHOUT INTELLIGENT KEY)

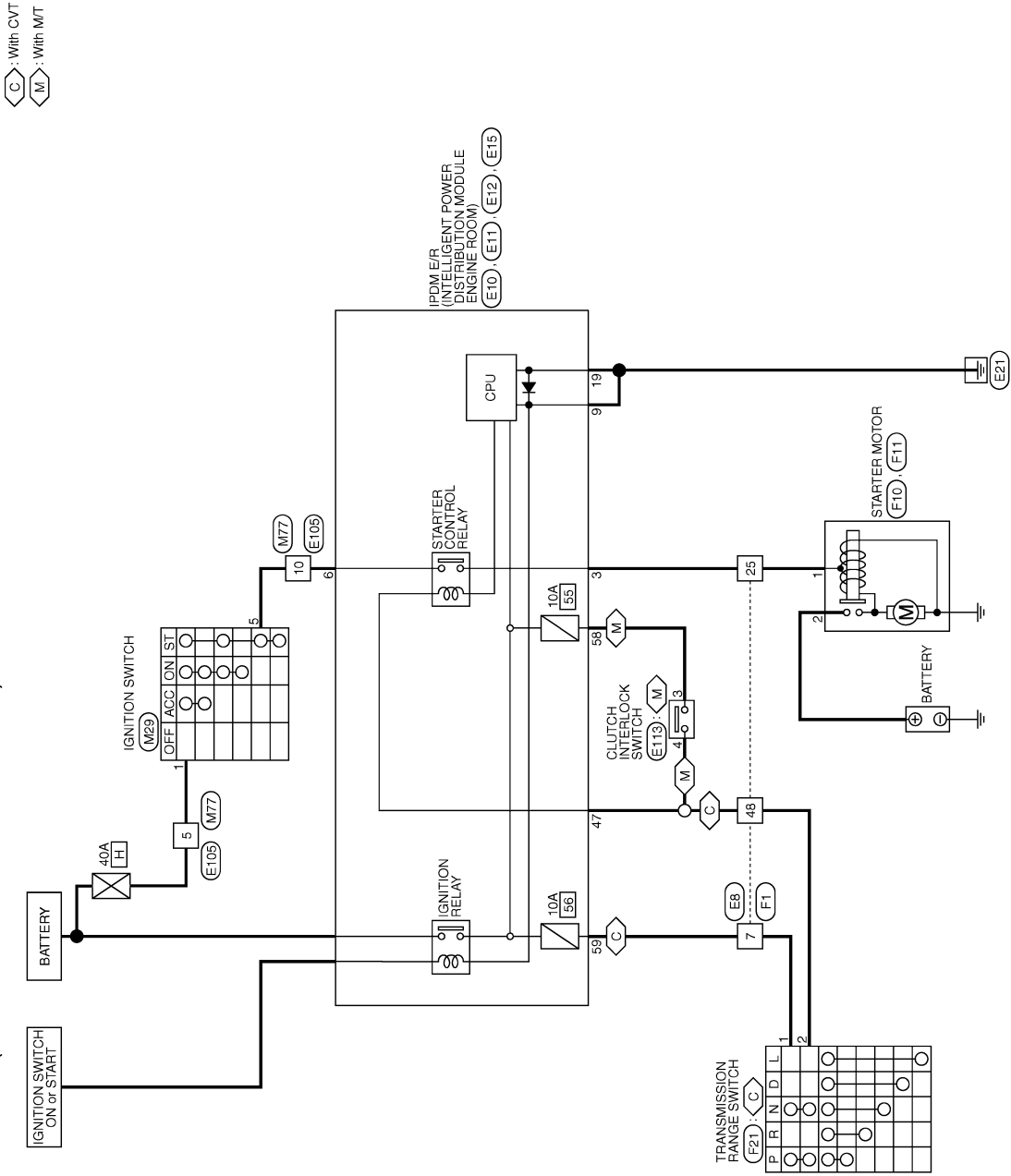

2009/02/27

JCBWM1304GB

STARTING SYSTEM

< DTC/CIRCUIT DIAGNOSIS >

STARTING SYSTEM (WITHOUT INTELLIGENT KEY)

Connector No.	EB
Connector Name	WIRE TO WIRE
Connector Type	SAC30MB-RS (0-SJZZ)



1	2	3	4	5	6	7	8	9	10	11	12	13	14	15	16	17	18	19	20	21	22	23	24	25	26	27	28	29	30	31	32	33	34	35	36	37	38	39	40	41	42	43	44	45	46	47	48	49	50	51	52	53	54	55	56	57	58	59	60	61	62	63	64	65	66	67	68	69	70	71	72	73	74	75	76	77	78	79	80	81	82	83	84	85	86	87	88	89	90	91	92	93	94	95	96	97	98	99	100
---	---	---	---	---	---	---	---	---	----	----	----	----	----	----	----	----	----	----	----	----	----	----	----	----	----	----	----	----	----	----	----	----	----	----	----	----	----	----	----	----	----	----	----	----	----	----	----	----	----	----	----	----	----	----	----	----	----	----	----	----	----	----	----	----	----	----	----	----	----	----	----	----	----	----	----	----	----	----	----	----	----	----	----	----	----	----	----	----	----	----	----	----	----	----	----	----	----	----	-----

Terminal No.	43	43	44	46	47	48
Color of Wire	R	LG	R	W	G	BR
Signal Name [Specification]	- [With CVT]	- [With M/T]	-	-	-	-

Connector No.	E10
Connector Name	FROM E/R INTELLIGENT POWER DISTRIBUTION MODULE (ENGINE ROOM)
Connector Type	MO8FW-LC



5	4	3	8	7	6
---	---	---	---	---	---

Terminal No.	3	4	5	6	7	8
Color of Wire	BR	P	LG	SB	Y	V
Signal Name [Specification]	-	-	-	-	-	-

Connector No.	E11
Connector Name	FROM E/R INTELLIGENT POWER DISTRIBUTION MODULE (ENGINE ROOM)
Connector Type	MO8FB-LC



11	10	9	14	13	12
----	----	---	----	----	----

Terminal No.	9	10	13
Color of Wire	B/W	L	W
Signal Name [Specification]	-	-	-

Connector No.	E12
Connector Name	FROM E/R INTELLIGENT POWER DISTRIBUTION MODULE (ENGINE ROOM)
Connector Type	NS08FBR-CS



17	16	15	22	21	20	19	18
----	----	----	----	----	----	----	----

Terminal No.	18	19	21	22
Color of Wire	Y	B/W	W	V
Signal Name [Specification]	-	-	-	-

Connector No.	E15
Connector Name	FROM E/R INTELLIGENT POWER DISTRIBUTION MODULE (ENGINE ROOM)
Connector Type	NS16FW-CS



53	52	51	50	49	48	47	82	61	60	59	58	57	56	55	54
----	----	----	----	----	----	----	----	----	----	----	----	----	----	----	----

Terminal No.	47	48	50	51	52	54	55	56	57	58	59	60	61	62
Color of Wire	BR	W	GR	R	P	GR	P	SB	G	R	Y	V	W	L
Signal Name [Specification]	-	-	-	-	-	-	-	-	-	- [With CVT]	-	-	-	-

JCBWM2619GB

A
STR
C
D
E
F
G
H
I
J
K
L
M
N
O
P

STARTING SYSTEM

< DTC/CIRCUIT DIAGNOSIS >

STARTING SYSTEM (WITHOUT INTELLIGENT KEY)

Connector No.	E105
Connector Name	WIRE TO WIRE
Connector Type	TH80MW-CS1E-TM4

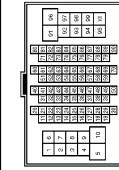

Terminal No.	Color of Wire	Signal Name [Specification]
1	V	-
2	W	-
3	SB	-
4	G	-
5	P	-
6	L	- [With NAVI]
8	R	- [Without NAVI]
9	Y	-
10	O	-
11	W	-
12	SB	-
31	V	-
32	R	-
33	GR	-
34	P	-
35	Y	-
36	BR	-
39	SB	-
44	R	-
45	V	-
46	P	-
48	L	-
51	BR	- [With CVT]
51	B	- [With M/T]
53	SB	-
54	W	- [With CVT]
54	O	- [With M/T]
57	LG	-
59	L	-
60	O	-
61	G	-
62	W	-
63	L	-
67	GR	- [With CVT]
67	V	- [With M/T]
68	P	-
70	SHIELD	-
71	GR	-

Connector No.	F1
Connector Name	WIRE TO WIRE
Connector Type	SAA38FB-RS1D-SJZ2

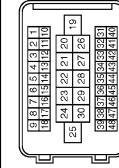

Terminal No.	Color of Wire	Signal Name [Specification]
1	SB	-
2	LG	-
3	R	-
4	Y	-
7	V	-
8	G	-
9	SB	-
10	L	-
11	Y	-
12	GR	-
13	BR	-
14	G	-
15	W	-
16	Y	-
17	P	-
18	BR	-
21	G	-
22	L	-
23	W	-
24	R	-
25	R	-
26	B	-
27	SB	-
28	V	-
29	V	-
30	BR	-
31	GR	-
32	BR	-
33	W	-
34	LG	-
35	V	-
36	Y	-
37	SB	- [For California]
37	W	- [Except for California]
39	G	-
40	P	-
41	O	-
42	G	-

43	R	-
44	P	-
46	GR	-
47	Y	-
48	BR	-

Connector No.	F10
Connector Name	STARTER MOTOR
Connector Type	-



Terminal No.	1	R	Signal Name [Specification]
--------------	---	---	-----------------------------

Connector No.	F11
Connector Name	STARTER MOTOR
Connector Type	-



Terminal No.	2	B/R	Signal Name [Specification]
--------------	---	-----	-----------------------------



Connector No.	E113
Connector Name	CLUTCH INTERLOCK SWITCH
Connector Type	MD4FW-LC



Terminal No.	3	Y	Signal Name [Specification]
4	BR	-	-

JCBWM2620GB

STARTING SYSTEM

< DTC/CIRCUIT DIAGNOSIS >

A

STR

C

D

E

F

G

H

I

J

K

L

M

N

O

P

STARTING SYSTEM (WITHOUT INTELLIGENT KEY)

Connector No.	F21
Connector Name	TRANSMISSION RANGE SWITCH
Connector Type	RK2BFG



Terminal No.	Color of Wire	Signal Name [Specification]
1	V	-
2	BR	-
3	R	-
4	GR	-
5	SB	-
6	W	-
7	Y	-
8	G	-

Connector No.	M29
Connector Name	IGNITION SWITCH
Connector Type	M08FW-LC



Terminal No.	Color of Wire	Signal Name [Specification]
1	L	-
2	G	-
3	W/R	-
4	Y/B	-
5	W	-

Connector No.	M77
Connector Name	WIRE TO WIRE
Connector Type	T18GFW-CS16-TM4

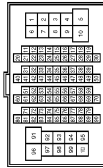

Terminal No.	Color of Wire	Signal Name [Specification]
1	B/O	-
2	R	-
3	G/R	-
4	G/B	-
5	L	-
6	W/R	-
7	G/W	-
8	Y/L	-
9	W	-
10	GR/L	-
31	L/B	-
32	R/Y	-
33	SB	-
34	BR	-
35	G	-
36	L/R	-
39	G/O	-
44	LG/R	-
45	GR/W	-
46	L/O	-
48	B/W	-
51	R/L	-
53	O	-
54	GR	-
57	V	-
58	R/W	-
60	V/W	-
61	W/L	-
62	W/B	-
63	Y/R	-
67	LG	-
68	SHIELD	-
70	P/B	-
71	R/G	-
72	L/Y	-
73	W/G	-
76	W/G	-

77	GR/R	-
78	O	-
79	LG	-
80	P	-
81	L	-
82	GR	-
83	G/R	-
84	B	-
87	G	-
91	R	-
92	O	-
93	Y	-
94	R/B	-
95	L/W	-
96	Y	-
97	L	-
98	BR/W	-
99	W	-
100	G/R	-

STARTING SYSTEM

< SYMPTOM DIAGNOSIS >

SYMPTOM DIAGNOSIS

STARTING SYSTEM

Symptom Table

INFOID:000000006502717

Symptom	Reference
No normal cranking	Refer to STR-2, "Work Flow" .
Starter motor does not rotate	

PRECAUTIONS

< PRECAUTION >

PRECAUTION

PRECAUTIONS

Precaution for Supplemental Restraint System (SRS) "AIR BAG" and "SEAT BELT PRE-TENSIONER"

INFOID:000000006919931

The Supplemental Restraint System such as "AIR BAG" and "SEAT BELT PRE-TENSIONER", used along with a front seat belt, helps to reduce the risk or severity of injury to the driver and front passenger for certain types of collision. This system includes seat belt switch inputs and dual stage front air bag modules. The SRS system uses the seat belt switches to determine the front air bag deployment, and may only deploy one front air bag, depending on the severity of a collision and whether the front occupants are belted or unbelted. Information necessary to service the system safely is included in the "SRS AIR BAG" and "SEAT BELT" of this Service Manual.

WARNING:

Always observe the following items for preventing accidental activation.

- To avoid rendering the SRS inoperative, which could increase the risk of personal injury or death in the event of a collision that would result in air bag inflation, all maintenance must be performed by an authorized NISSAN/INFINITI dealer.
- Improper maintenance, including incorrect removal and installation of the SRS, can lead to personal injury caused by unintentional activation of the system. For removal of Spiral Cable and Air Bag Module, see "SRS AIR BAG".
- Never use electrical test equipment on any circuit related to the SRS unless instructed to in this Service Manual. SRS wiring harnesses can be identified by yellow and/or orange harnesses or harness connectors.

PRECAUTIONS WHEN USING POWER TOOLS (AIR OR ELECTRIC) AND HAMMERS

WARNING:

Always observe the following items for preventing accidental activation.

- When working near the Air Bag Diagnosis Sensor Unit or other Air Bag System sensors with the ignition ON or engine running, never use air or electric power tools or strike near the sensor(s) with a hammer. Heavy vibration could activate the sensor(s) and deploy the air bag(s), possibly causing serious injury.
- When using air or electric power tools or hammers, always switch the ignition OFF, disconnect the battery, and wait at least 3 minutes before performing any service.

A

STR

C

D

E

F

G

H

I

J

K

L

M

N

O

P

PREPARATION

< PREPARATION >

PREPARATION

PREPARATION

Special Service Tools

INFOID:000000006502719

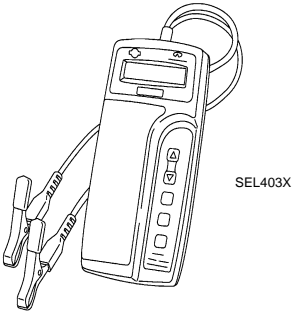
Tool number (Kent-Moore No.) Tool name	Description
<p>— (J-44373 Model MCR620) Starting/Charging System Tester</p>  <p>SEL403X</p>	<p>Tests starting and charging systems. For operating instructions, refer to Technical Service Bulletin.</p>

Commercial Service Tools

INFOID:000000006502720

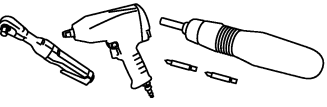
Tool name	Description
<p>Power tool</p>  <p>PIIB1407E</p>	<p>Loosening bolts, nuts and screws</p>

STARTER MOTOR

< REMOVAL AND INSTALLATION >

REMOVAL AND INSTALLATION

STARTER MOTOR

Exploded View

INFOID:000000006502721

A

STR

REMOVAL

C

D

E

F

G

H

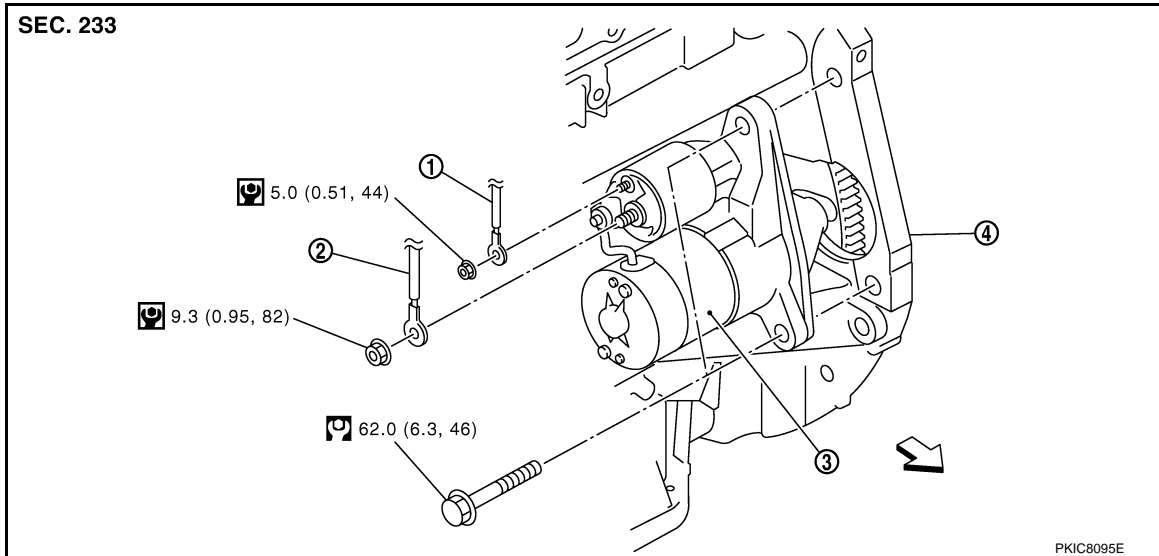

1. "S" terminal harness

2. "B" terminal harness

3. Starter motor

4. Cylinder block

↔: Vehicle front

Refer to [GI-4, "Components"](#) for symbols in the figure.

I

J

DISASSEMBLY

K

L

M

N

O

P

STARTER MOTOR

< REMOVAL AND INSTALLATION >

Type: S114-955

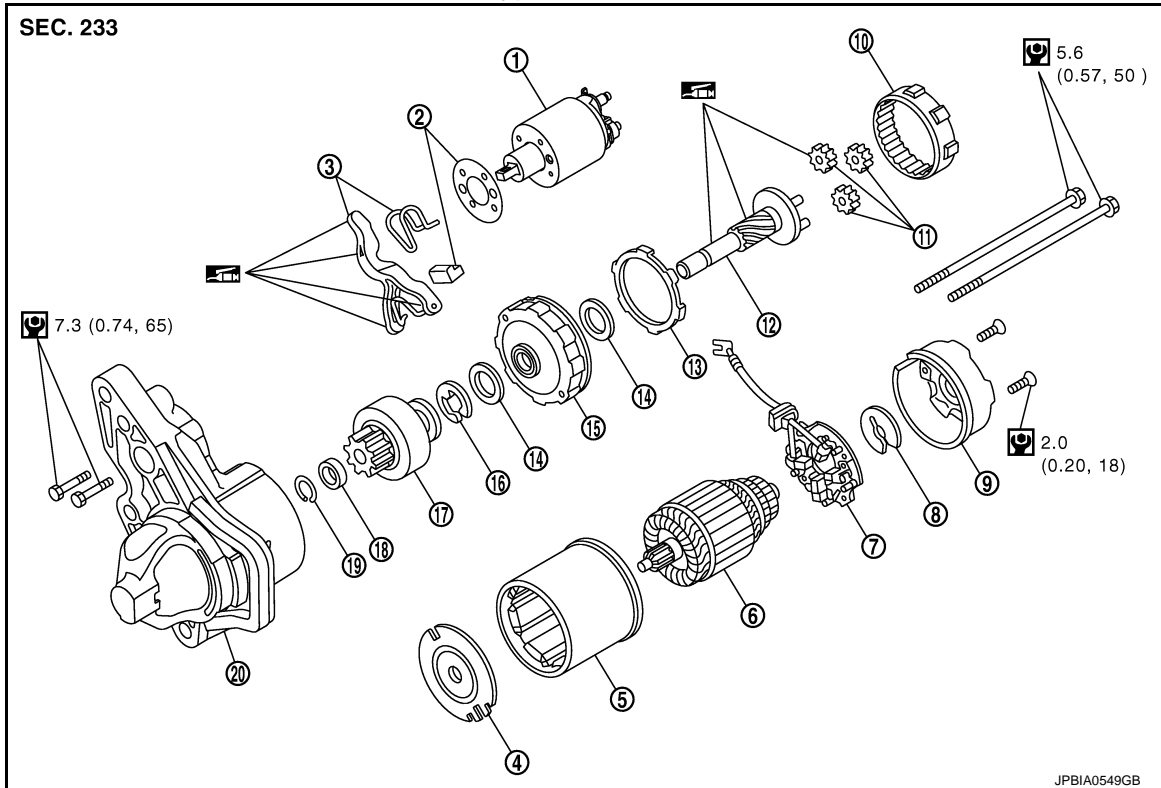

- | | | |
|-----------------------------|------------------------|------------------------|
| 1. Magnetic switch assembly | 2. Dust cover kit | 3. Shift lever set |
| 4. Center bracket (A) | 5. Yoke assembly | 6. Armature assembly |
| 7. Brush holder assembly | 8. Thrust washer | 9. Rear cover assembly |
| 10. Internal gear | 11. Planetary gear | 12. Pinion shaft |
| 13. Packing | 14. Thrust washer | 15. Center bracket (P) |
| 16. E-ring | 17. Pinion assembly | 18. Pinion stopper |
| 19. Pinion stopper clip | 20. Gear case assembly | |

 : High-temperature grease point

Refer to [GI-4, "Components"](#) for symbols not described on the above.

STARTER MOTOR

< REMOVAL AND INSTALLATION >

Type: S114-944

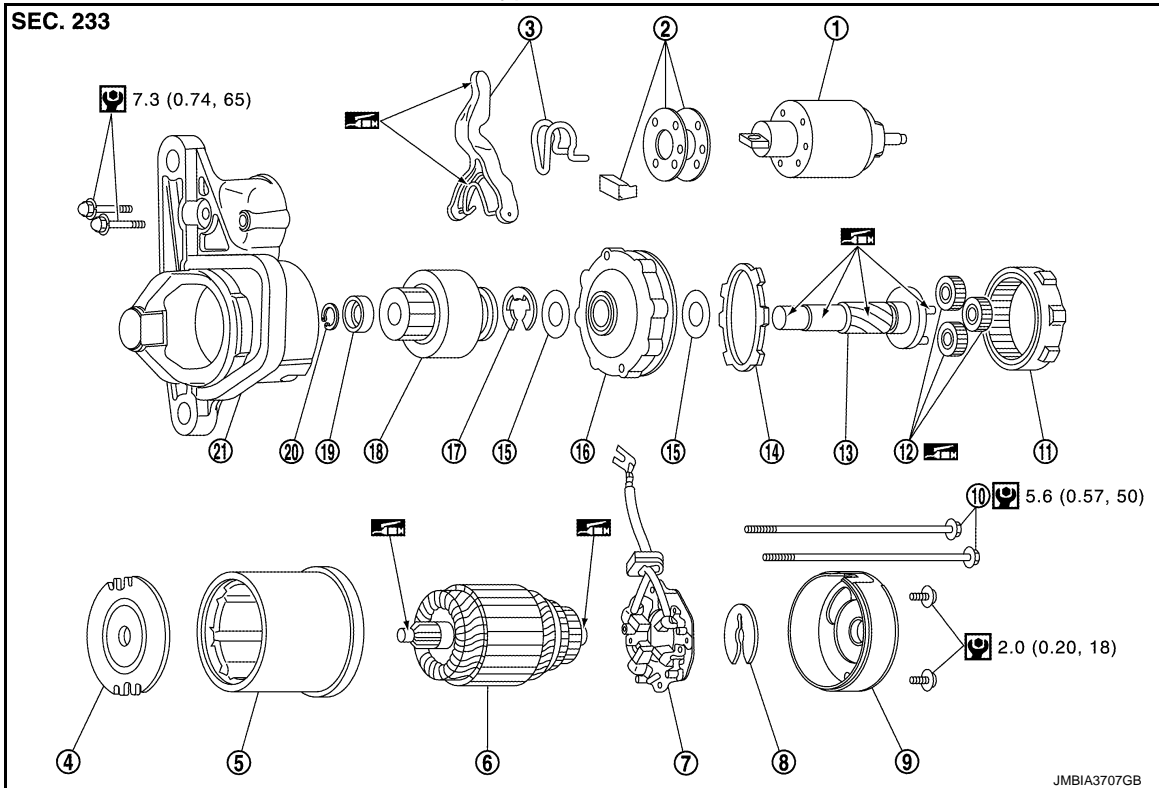

- | | | |
|-----------------------------|-------------------------|------------------------|
| 1. Magnetic switch assembly | 2. Dust cover kit | 3. Shift lever set |
| 4. Center bracket (A) | 5. Yoke assembly | 6. Armature assembly |
| 7. Brush holder assembly | 8. Thrust washer | 9. Rear cover assembly |
| 10. Through bolt | 11. Internal gear | 12. Planetary gear |
| 13. Pinion shaft | 14. Packing | 15. Thrust washer |
| 16. Center bracket (P) | 17. E-ring | 18. Pinion assembly |
| 19. Pinion stopper | 20. Pinion stopper clip | 21. Gear case assembly |

 : High-temperature grease point

Refer to [GI-4, "Components"](#) for symbols not described on the above.

NOTE:

Apply high-temperature grease to lubricate the bearing, gears and frictional surface when assembling the starter.

Removal and Installation

INFOID:000000006502722

REMOVAL

1. Disconnect the battery cable from the negative terminal.
2. Remove air duct (inlet). Refer to [EM-24, "Exploded View"](#).
3. Remove radiator reservoir tank.
4. Disconnect oil pressure switch connector.
5. Remove "B" terminal nut and "B" terminal harness.
6. Remove "S" terminal nut and "S" terminal harness.
7. Remove starter motor mounting bolts.
8. Remove starter motor upward from the vehicle.

INSTALLATION

Install in the reverse order of removal.

CAUTION:

Be sure to tighten "B" terminal nut carefully.

STARTER MOTOR

< REMOVAL AND INSTALLATION >

Inspection

INFOID:000000006502723

INSPECTION AFTER DISASSEMBLY

Pinion/Clutch Check

1. Inspect pinion teeth.
 - Replace pinion if teeth are worn or damaged. (Also check condition of ring gear teeth.)
2. Inspect reduction gear teeth.
 - Replace reduction gear if teeth are worn or damaged. (Also check condition of armature shaft gear teeth.)
3. Check to see if pinion locks in one direction and rotates smoothly in the opposite direction.
 - If it locks or rotates in both directions, or unusual resistance is evident, replace.

SERVICE DATA AND SPECIFICATIONS (SDS)

< SERVICE DATA AND SPECIFICATIONS (SDS)

SERVICE DATA AND SPECIFICATIONS (SDS)

SERVICE DATA AND SPECIFICATIONS (SDS)

Starter Motor

INFOID:0000000006502724

A

STR

Destination		For California	Except for California
		S114-944	S114-955
Type		HITACHI make	
		Reduction gear type	
System voltage [V]		12	
No-load	Terminal voltage [V]	11	
	Current [A]	Less than 110	
	Revolution [rpm]	More than 3,750	More than 3,000
Minimum diameter of commutator [mm (in)]		28.0 (1.102)	
Minimum length of brush [mm (in)]		10.5 (0.413)	
Brush spring tension [N (kg, lb)]		16.2 (1.65, 3.6)	
Clearance between bearing metal and armature shaft [mm (in)]		Less than 0.2 (0.008)	
Clearance between pinion front edge and pinion stopper [mm (in)]		0.3 - 2.5 (0.012 – 0.098)	

C

D

E

F

G

H

I

J

K

L

M

N

O

P