

WT
SECTION
ROAD WHEELS & TIRES

A
B
C
D

WT

CONTENTS

REGULAR GRADE		
PRECAUTION	DIAGNOSIS SYSTEM (BCM) (WITHOUT INTELLIGENT KEY SYSTEM)	F
3	12	
PRECAUTIONS	COMMON ITEM	G
3	12	
Precaution for Supplemental Restraint System (SRS) "AIR BAG" and "SEAT BELT PRE-TENSIONER"	COMMON ITEM : CONSULT-III Function (BCM - COMMON ITEM)	
3	12	
Service Notice and Precautions for TPMS	AIR PRESSURE MONITOR	H
3	12	
Service Notice and Precautions for Road Wheel	AIR PRESSURE MONITOR : CONSULT-III Function	
3	13	
PREPARATION	ECU DIAGNOSIS INFORMATION	I
5	15	
PREPARATION	BCM	J
5	15	
Special Service Tool	WITH INTELLIGENT KEY	
5	15	
Commercial Service Tool	WITH INTELLIGENT KEY : List of ECU Reference	K
5	15	
SYSTEM DESCRIPTION	WITHOUT INTELLIGENT KEY	L
6	15	
COMPONENT PARTS	WITHOUT INTELLIGENT KEY : List of ECU Reference	
6	15	
Component Parts Location	WIRING DIAGRAM	M
6	16	
Component Description	TIRE PRESSURE MONITORING SYSTEM	
6	16	
BCM	Wiring Diagram	N
7	16	
Transmitter	BASIC INSPECTION	
7	20	
Tire pressure receiver	DIAGNOSIS AND REPAIR WORK FLOW	O
7	20	
SYSTEM	Work Flow	P
8	22	
TIRE PRESSURE MONITORING SYSTEM	TRANSMITTER WAKE UP OPERATION	
8	22	
TIRE PRESSURE MONITORING SYSTEM : System Description	Description	
8	22	
DIAGNOSIS SYSTEM (BCM) (WITH INTELLIGENT KEY SYSTEM)	Work Procedure	
9	22	
COMMON ITEM	ID REGISTRATION PROCEDURE	
9	23	
COMMON ITEM : CONSULT-III Function (BCM - COMMON ITEM)	Description	
9	23	
AIR PRESSURE MONITOR	Work Procedure	
10	23	
AIR PRESSURE MONITOR : CONSULT-III Function	DTC/CIRCUIT DIAGNOSIS	
10	25	

C1704, C1705, C1706, C1707 LOW TIRE PRESSURE	25	Diagnosis Procedure	40
Description	25	ID REGISTRATION CANNOT BE COMPLETED	41
DTC Logic	25	Description	41
Diagnosis Procedure	25	Diagnosis Procedure	41
Special Repair Requirement	26	NOISE, VIBRATION AND HARSHNESS (NVH) TROUBLESHOOTING	42
C1708, C1709, C1710, C1711 TRANSMITTER	27	NVH Troubleshooting Chart	42
DTC Logic	27	PERIODIC MAINTENANCE	43
Diagnosis Procedure	27	ROAD WHEEL	43
Special Repair Requirement	29	Adjustment	43
C1716, C1717, C1718, C1719 TRANSMITTER	30	REMOVAL AND INSTALLATION	45
DTC Logic	30	ROAD WHEEL TIRE ASSEMBLY	45
Diagnosis Procedure	30	Exploded View	45
Special Repair Requirement	31	Removal and Installation	45
C1729 VEHICLE SPEED SIGNAL	32	Inspection	45
Description	32	TRANSMITTER	47
DTC Logic	32	WITH INTELLIGENT KEY	47
Diagnosis Procedure	32	WITH INTELLIGENT KEY : Exploded View	47
Special Repair Requirement	32	WITH INTELLIGENT KEY : Removal and Installation	47
LOW TIRE PRESSURE WARNING LAMP	33	WITHOUT INTELLIGENT KEY	49
Component Function Check	33	WITHOUT INTELLIGENT KEY : Exploded View	50
Diagnosis Procedure	33	WITHOUT INTELLIGENT KEY : Removal and Installation	50
POWER SUPPLY AND GROUND CIRCUIT	34	TIRE PRESSURE RECEIVER	52
Diagnosis Procedure	34	Removal and Installation	52
SYMPTOM DIAGNOSIS	35	SERVICE DATA AND SPECIFICATIONS (SDS)	53
TPMS	35	SERVICE DATA AND SPECIFICATIONS (SDS)	53
Symptom Table	35	Road Wheel	53
LOW TIRE PRESSURE WARNING LAMP DOES NOT BLINKS	38	Tire Air Pressure	53
Description	38	Krom	
Diagnosis Procedure	38	SPEC CHANGE INFORMATION	54
LOW TIRE PRESSURE WARNING LAMP DOES NOT TURN OFF	39	ROAD WHEEL TIRE ASSEMBLY	54
Description	39	Road Wheel Tire Assembly	54
Diagnosis Procedure	39		
LOW TIRE PRESSURE WARNING LAMP BLINKS	40		
Description	40		

PRECAUTION

PRECAUTIONS

Precaution for Supplemental Restraint System (SRS) "AIR BAG" and "SEAT BELT PRE-TENSIONER"

INFOID:000000006504186

The Supplemental Restraint System such as "AIR BAG" and "SEAT BELT PRE-TENSIONER", used along with a front seat belt, helps to reduce the risk or severity of injury to the driver and front passenger for certain types of collision. This system includes seat belt switch inputs and dual stage front air bag modules. The SRS system uses the seat belt switches to determine the front air bag deployment, and may only deploy one front air bag, depending on the severity of a collision and whether the front occupants are belted or unbelted. Information necessary to service the system safely is included in the "SRS AIR BAG" and "SEAT BELT" of this Service Manual.

WARNING:

Always observe the following items for preventing accidental activation.

- To avoid rendering the SRS inoperative, which could increase the risk of personal injury or death in the event of a collision that would result in air bag inflation, all maintenance must be performed by an authorized NISSAN/INFINITI dealer.
- Improper maintenance, including incorrect removal and installation of the SRS, can lead to personal injury caused by unintentional activation of the system. For removal of Spiral Cable and Air Bag Module, see "SRS AIR BAG".
- Never use electrical test equipment on any circuit related to the SRS unless instructed to in this Service Manual. SRS wiring harnesses can be identified by yellow and/or orange harnesses or harness connectors.

PRECAUTIONS WHEN USING POWER TOOLS (AIR OR ELECTRIC) AND HAMMERS

WARNING:

Always observe the following items for preventing accidental activation.

- When working near the Air Bag Diagnosis Sensor Unit or other Air Bag System sensors with the ignition ON or engine running, never use air or electric power tools or strike near the sensor(s) with a hammer. Heavy vibration could activate the sensor(s) and deploy the air bag(s), possibly causing serious injury.
- When using air or electric power tools or hammers, always switch the ignition OFF, disconnect the battery, and wait at least 3 minutes before performing any service.

Service Notice and Precautions for TPMS

INFOID:000000006934371

- Low tire pressure warning lamp blinks for 1min, then turns ON when occurring any malfunction except low tire pressure. Erase the self-diagnosis memories for Tire Pressure Monitoring System (TPMS), or register the ID to turn low tire pressure warning lamp OFF. For ID registration, refer to [WT-23, "Work Procedure"](#).
- ID registration is required when replacing or rotating wheels, replacing tire pressure sensor or BCM. Refer to [WT-23, "Work Procedure"](#).
- Replace grommet seal, valve core and valve cap of tire pressure sensor in TPMS, when replacing each tire by reaching the wear limit. Refer to [WT-47, "WITH INTELLIGENT KEY : Exploded View"](#) (With intelligent key system), [WT-50, "WITHOUT INTELLIGENT KEY : Exploded View"](#) (Without intelligent key system).
- Because the tire pressure sensor conforms to North America radio law, the following items must be observed.
 - The sensor may be used only in North America.
 - It may not be used in any method other than the specified method.
 - It must not be disassembled or modified.

Service Notice and Precautions for Road Wheel

INFOID:000000006934372

- Genuine NISSAN aluminum wheel is designed for each type of vehicle. Use it on the specified vehicle only.
- Use Genuine NISSAN parts for the road wheels, valve caps and wheel nuts.
- Always use them after adjusting the wheel balance. For the balance weights, use Genuine NISSAN aluminum wheel weights.
- Use caution when handling the aluminum wheels, because they can be easily scratched. When removing dirt, do not use any abrasives, a wire brush, or other items that may scratch the coating. Use a neutral detergent if a detergent is needed.

A
B
C
D
WT
F
G
H
I
J
K
L
M
N
O
P

PRECAUTIONS

[REGULAR GRADE]

< PRECAUTION >

-
- After driving on roads scattered with anti-icing salts, wash off the wheels completely.
 - When installing road wheels onto the vehicle, always wipe off any dirt or foreign substances to prevent them from being trapped between the contact surfaces of wheel.
 - Never apply oil to nut and bolt threads.
 - When tightening the valve cap there is a risk of damaging the valve cap if a tool is used. Tighten by hand.

PREPARATION

< PREPARATION >

[REGULAR GRADE]

PREPARATION

PREPARATION

Special Service Tool

INFOID:000000006504189

The actual shapes of Kent-Moore tools may differ from those of special service tools illustrated here.

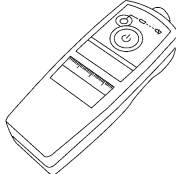
Tool number (Kent-Moore No.) Tool name	Description
- (J-45295) Activation tool  SEIA0462E	Transmitter wake-up procedure and ID registration

A

B

C

D

WT

Commercial Service Tool

INFOID:000000006504190

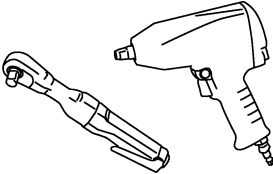
Tool name	Description
Power tool  PBIC0190E	Loosening wheel nuts

F

G

H

I

J

K

L

M

N

O

P

SYSTEM DESCRIPTION

COMPONENT PARTS

Component Parts Location

INFOID:000000006504191

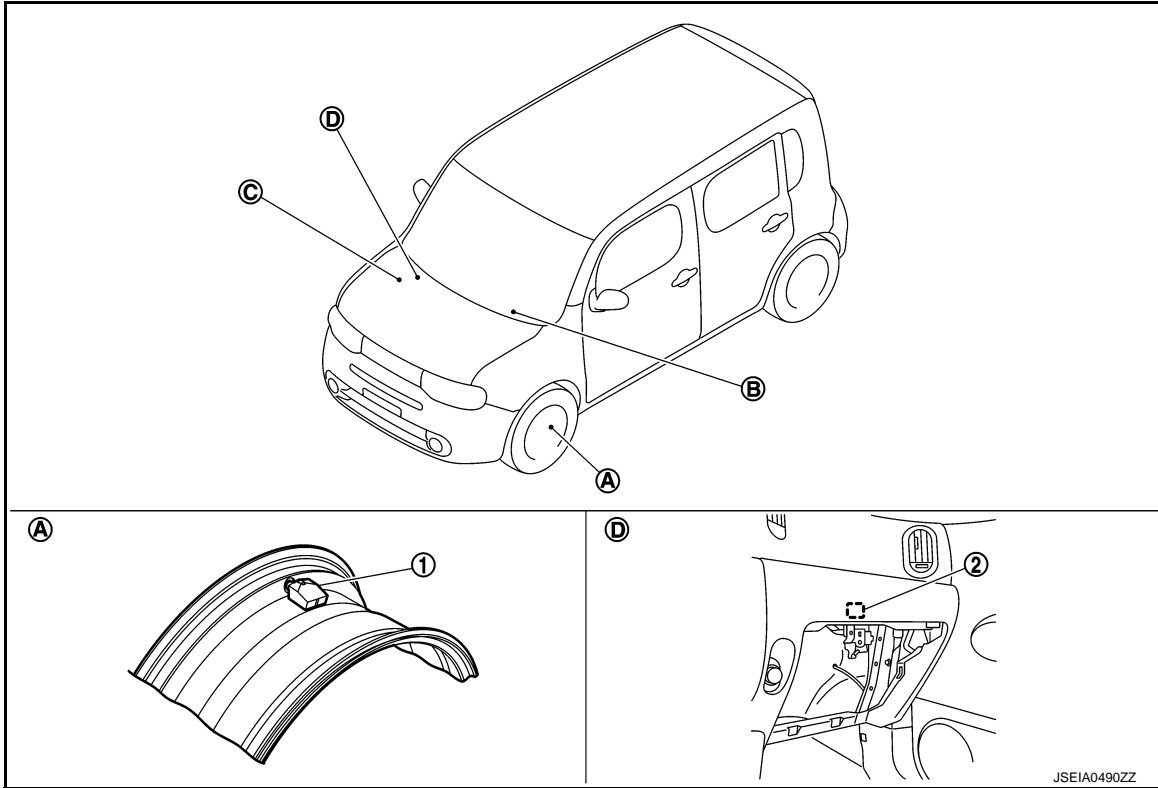

- 1. Transmitter
- 2. Tire pressure receiver
- A. Wheel
- B. Low tire pressure warning lamp (On the combination meter)
- C. BCM
Refer to [BCS-9, "Component Parts Location"](#) (With intelligent key system), [BCS-84, "Component Parts Location"](#) (Without intelligent key system).
- D. Glove box assembly

Component Description

INFOID:000000006504192

Component parts	Function
BCM (Body Control Module)	WT-7, "BCM" .
Transmitter	WT-7, "Transmitter" .
Tire pressure receiver	WT-7, "Tire pressure receiver" .
Turn signal lamp	ID registration of each wheel has been completed, turn signal lamp flashes.
Combination meter	Transmits the vehicle speed signal via CAN communication to BCM.
	Receives the following signals via CAN communication for BCM. <ul style="list-style-type: none"> • Low tire pressure warning lamp signal • TPMS warning lamp signal
Low tire pressure warning lamp	WT-8, "TIRE PRESSURE MONITORING SYSTEM : System Description"

COMPONENT PARTS

< SYSTEM DESCRIPTION >

[REGULAR GRADE]

BCM

INFOID:000000006504193

The BCM reads the tire pressure signal received by the tire pressure receiver, and controls the low tire pressure warning lamp and the buzzer operations. It also has a judgment function to detect a system malfunction.

Transmitter

INFOID:000000006504194

The transmitter integrated with a valve is installed on a wheel, and transmits a detected tire pressure signal by radio wave.

Tire pressure receiver

INFOID:000000006504195

The tire pressure receiver receives the tire pressure signal transmitted by the transmitter in each wheel.

A
B
C
D

WT

F
G
H
I
J
K
L
M
N
O
P

SYSTEM

TIRE PRESSURE MONITORING SYSTEM

TIRE PRESSURE MONITORING SYSTEM : System Description

INFOID:000000006933559

During driving, the TPMS (Tire Pressure Monitoring System) receives the signal transmitted from transmitter installed in each wheel. The BCM (Body Control Module) of this system has pressure judgment and trouble diagnosis functions. When the tire pressure monitoring system detects low inflation pressure or another unusual symptom, the low tire pressure warning lamps in the combination meter. comes on.

SYSTEM DIAGRAM

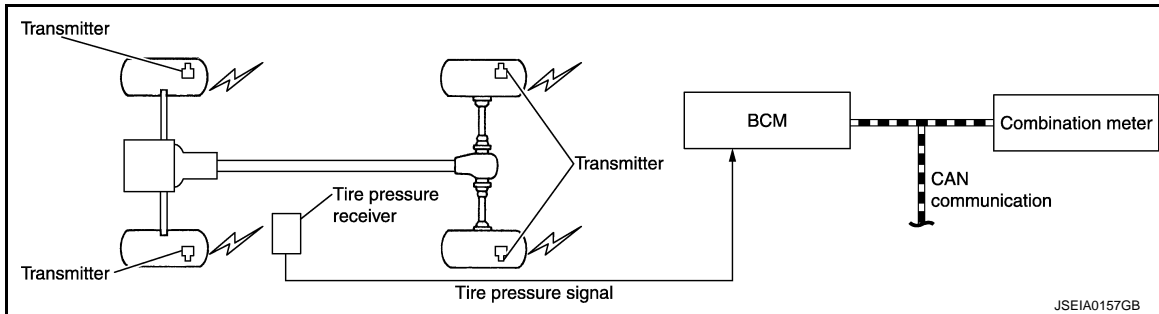

INPUT/OUTPUT SIGNAL

The signal transmission/reception between units via a communication line is mainly as listed in the following table.

Component parts	Signal item
BCM	Transmits the following signals via CAN communication to combination meter. <ul style="list-style-type: none"> • Low tire pressure warning lamp signal • TPMS warning lamp signal
Combination meter	Transmits the vehicle speed signal via CAN communication to BCM.

LOW TIRE PRESSURE WARNING LAMP INDICATION CONDITION

Uses CAN communication from the BCM to illuminate the low tire pressure warning lamp on the combination meter.

Condition	Low tire pressure warning lamp
Ignition switch OFF	OFF
Ignition switch ON (system normal)	Warning lamp turns on for 1second, then turns off.
Low tire pressure	ON
Transmitter ID not registered in BCM.	
Tire pressure monitoring system malfunction (Other diagnostic item)	Warning lamp blinks 1 min, then turns on.
Tire pressure sensor is in OFF state	Blink (Blinking pattern depends on the positions of nonoperational tire pressure sensors.)

DIAGNOSIS SYSTEM (BCM) (WITH INTELLIGENT KEY SYSTEM)

< SYSTEM DESCRIPTION >

[REGULAR GRADE]

DIAGNOSIS SYSTEM (BCM) (WITH INTELLIGENT KEY SYSTEM) COMMON ITEM

COMMON ITEM : CONSULT-III Function (BCM - COMMON ITEM)

INFOID:0000000006968163

APPLICATION ITEM

CONSULT-III performs the following functions via CAN communication with BCM.

Diagnosis mode	Function Description
Work Support	Changes the setting for each system function.
Self Diagnostic Result	Displays the diagnosis results judged by BCM.
CAN Diag Support Monitor	Monitors the reception status of CAN communication viewed from BCM. Refer to CONSULT-III operation manual.
Data Monitor	The BCM input/output signals are displayed.
Active Test	The signals used to activate each device are forcibly supplied from BCM.
Ecu Identification	The BCM part number is displayed.
Configuration	<ul style="list-style-type: none"> Read and save the vehicle specification. Write the vehicle specification when replacing BCM.

SYSTEM APPLICATION

BCM can perform the following functions for each system.

NOTE:

It can perform the diagnosis modes except the following for all sub system selection items.

x: Applicable item

System	Sub system selection item	Diagnosis mode		
		Work Support	Data Monitor	Active Test
Door lock	DOOR LOCK	x	x	x
Rear window defogger	REAR DEFOGGER		x	x
Warning chime	BUZZER		x	x
Interior room lamp timer	INT LAMP	x	x	x
Exterior lamp	HEAD LAMP	x	x	x
Wiper and washer	WIPER	x	x	x
Turn signal and hazard warning lamps	FLASHER	x	x	x
Automatic air conditioner	AIR CONDITONER		x	x
<ul style="list-style-type: none"> Intelligent Key system Engine start system 	INTELLIGENT KEY	x	x	x
Combination switch	COMB SW		x	
Body control system	BCM	x		
NVIS - NATS	IMMU	x	x	x
Interior room lamp battery saver	BATTERY SAVER	x	x	x
Back door	TRUNK		x	
Vehicle security system	THEFT ALM	x	x	x
RAP system	RETAINED PWR		x	
Signal buffer system	SIGNAL BUFFER		x	x
TPMS	TPMS (AIR PRESSURE MONITOR)	x	x	x

FREEZE FRAME DATA (FFD)

The BCM records the following vehicle condition at the time a particular DTC is detected, and displays on CONSULT-III.

DIAGNOSIS SYSTEM (BCM) (WITH INTELLIGENT KEY SYSTEM)

< SYSTEM DESCRIPTION >

[REGULAR GRADE]

CONSULT screen item	Indication/Unit	Description	
Vehicle Speed	km/h	Vehicle speed of the moment a particular DTC is detected	
Odo/Trip Meter	km	Total mileage (Odometer value) of the moment a particular DTC is detected	
Vehicle Condition	SLEEP>LOCK	Power position status of the moment a particular DTC is detected	While turning BCM status from low power consumption mode to normal mode (Power supply position is "LOCK"*)
	SLEEP>OFF		While turning BCM status from low power consumption mode to normal mode (Power supply position is "OFF".)
	LOCK>ACC		While turning power supply position from "LOCK"* to "ACC"
	ACC>ON		While turning power supply position from "ACC" to "IGN"
	RUN>ACC		While turning power supply position from "RUN" to "ACC" (Vehicle is stopping and selector lever is except P position.)
	CRANK>RUN		While turning power supply position from "CRANKING" to "RUN" (From cranking up the engine to run it)
	RUN>URGENT		While turning power supply position from "RUN" to "ACC" (Emergency stop operation)
	ACC>OFF		While turning power supply position from "ACC" to "OFF"
	OFF>LOCK		While turning power supply position from "OFF" to "LOCK"*
	OFF>ACC		While turning power supply position from "OFF" to "ACC"
	ON>CRANK		While turning power supply position from "IGN" to "CRANKING"
	OFF>SLEEP		While turning BCM status from normal mode (Power supply position is "OFF".) to low power consumption mode
	LOCK>SLEEP		While turning BCM status from normal mode (Power supply position is "LOCK"*.) to low power consumption mode
	LOCK		Power supply position is "LOCK"*
	OFF		Power supply position is "OFF" (Ignition switch OFF)
	ACC		Power supply position is "ACC" (Ignition switch ACC)
	ON		Power supply position is "IGN" (Ignition switch ON with engine stopped)
	ENGINE RUN		Power supply position is "RUN" (Ignition switch ON with engine running)
	CRANKING		Power supply position is "CRANKING" (At engine cranking)
IGN Counter	0 - 39	The number of times that ignition switch is turned ON after DTC is detected <ul style="list-style-type: none"> • The number is 0 when a malfunction is detected now. • The number increases like 1 → 2 → 3...38 → 39 after returning to the normal condition whenever ignition switch OFF → ON. • The number is fixed to 39 until the self-diagnosis results are erased if it is over 39. 	

NOTE:

*: Power position shifts to "LOCK" from "OFF", when ignition switch is in the OFF position, selector lever is in the P position (CVT models), and any of the following conditions are met.

- Closing door
- Opening door
- Door is locked using door request switch
- Door is locked using Intelligent Key

The power position shifts to "ACC" when the push-button ignition switch (push switch) is pushed at "LOCK".

AIR PRESSURE MONITOR

AIR PRESSURE MONITOR : CONSULT-III Function

INFOID:000000006504203

FUNCTION

The diagnosis functions (main functions) include the following: "WORK SUPPORT", "SELF DIAGNOSTIC RESULT", "DATA MONITOR" and "ACTIVE TEST".

DIAGNOSIS SYSTEM (BCM) (WITH INTELLIGENT KEY SYSTEM)

< SYSTEM DESCRIPTION >

[REGULAR GRADE]

Diagnostic test mode	Function
Work support	In this mode, it is possible to make quick and accurate adjustments by following the instructions on the CONSULT-III display.
Self diagnostic result	Receives self-diagnosis results from the BCM, and indicates DTCs and the number of malfunctions.
Data monitor	Receives input/output signals from the BCM and indicates and stores them to facilitate locating the causes of malfunctions.
Active test	Transmits command to the BCM to change output signals and check operation of output system.

WORK SUPPORT MODE

Refer to [WT-23, "Work Procedure"](#).

SELF-DIAG RESULTS MODE

Refer to [BCS-73, "DTC Index"](#).

DATA MONITOR MODE

Screen of data monitor mode is displayed.

NOTE:

When malfunction is detected, CONSULT-III perform REAL-TIME DIAGNOSIS. Also, any malfunction detected while in this mode will be displayed at real time.

Monitor item (Unit)	Remark
AIR PRESS FL (kPa), (kg/cm ²), (Psi)	Air pressure of tires
AIR PRESS FR (kPa), (kg/cm ²), (Psi)	
AIR PRESS RR (kPa), (kg/cm ²), (Psi)	
AIR PRESS RL (kPa), (kg/cm ²), (Psi)	
ID REGST FL1	ID is registered: Done ID is not registered: Yet
ID REGST FR1	
ID REGST RR1	
ID REGST RL1	
WARNING LAMP	Low tire pressure warning lamp ON: On Low tire pressure warning lamp OFF: Off
BUZZER	Combination meter buzzer ON: On Combination meter buzzer OFF: Off

NOTE:

Before performing the self-diagnosis, be sure to register the ID, or erase the actual malfunction location may be different from that displayed on CONSULT-III.

ACTIVE TEST MODE

NOTE:

Before performing the self-diagnosis, be sure to register the ID, or erase the actual malfunction may be different from that displayed on CONSULT-III.

TEST ITEM LIST

Test item	Content
WARNING LAMP	This test is able to check to check that the low tire pressure warning lamp turns on.
ID REGIST WARNING	This test is able to check to check that the buzzer sounds or the low tire pressure warning lamp turns on.
RUN FLAT TIRE W/L	NOTE: This item is displayed, but cannot be use this item.
FLASHER	This test is able to check to check that each turn signal lamp turns on.
HORN	This test is able to check to check that the horn sounds.

DIAGNOSIS SYSTEM (BCM) (WITHOUT INTELLIGENT KEY SYSTEM)

[REGULAR GRADE]

< SYSTEM DESCRIPTION >

DIAGNOSIS SYSTEM (BCM) (WITHOUT INTELLIGENT KEY SYSTEM) COMMON ITEM

COMMON ITEM : CONSULT-III Function (BCM - COMMON ITEM)

INFOID:000000006968164

APPLICATION ITEM

CONSULT-III performs the following functions via CAN communication with BCM.

Diagnosis mode	Function Description
Work Support	Changes the setting for each system function.
Self Diagnostic Result	Displays the diagnosis results judged by BCM.
CAN Diag Support Monitor	Monitors the reception status of CAN communication viewed from BCM. Refer to CONSULT-III operation manual.
Data Monitor	The BCM input/output signals are displayed.
Active Test	The signals used to activate each device are forcibly supplied from BCM.
Ecu Identification	The BCM part number is displayed.
Configuration	<ul style="list-style-type: none"> • Read and save the vehicle specification. • Write the vehicle specification when replacing BCM.

SYSTEM APPLICATION

BCM can perform the following functions for each system.

NOTE:

It can perform the diagnosis modes except the following for all sub system selection items.

×: Applicable item

System	Sub system selection item	Diagnosis mode		
		Work Support	Data Monitor	Active Test
Door lock	DOOR LOCK	×	×	×
Rear window defogger	REAR DEFOGGER		×	×
Warning chime	BUZZER		×	×
Interior room lamp control	INT LAMP	×	×	×
Remote keyless entry system	MULTI REMOTE ENT	×	×	×
Exterior lamp	HEAD LAMP	×	×	×
Wiper and washer	WIPER	×	×	×
Turn signal and hazard warning lamps	FLASHER		×	×
<ul style="list-style-type: none"> • Automatic air conditioner • Manual air conditioner 	AIR CONDITONER		×	×
Combination switch	COMB SW		×	
Body control system	BCM	×		
NVIS - NATS	IMMU	×	×	×
Interior room lamp battery saver	BATTERY SAVER	×	×	×
Back door	TRUNK		×	
Vehicle security system	THEFT ALM	×	×	×
RAP system	RETAINED PWR		×	×
Signal buffer system	SIGNAL BUFFER		×	×
TPMS	TPMS (AIR PRESSURE MONITOR)	×	×	×
Panic alarm system	PANIC ALARM			×

AIR PRESSURE MONITOR

DIAGNOSIS SYSTEM (BCM) (WITHOUT INTELLIGENT KEY SYSTEM)

< SYSTEM DESCRIPTION >

[REGULAR GRADE]

AIR PRESSURE MONITOR : CONSULT-III Function

INFOID:000000006504206

FUNCTION

The diagnosis functions (main functions) include the following: "WORK SUPPORT", "SELF DIAGNOSTIC RESULT", "DATA MONITOR" and "ACTIVE TEST".

Diagnostic test mode	Function
Work support	In this mode, it is possible to make quick and accurate adjustments by following the instructions on the CONSULT-III display.
Self diagnostic result	Receives self-diagnosis results from the BCM, and indicates DTCs and the number of malfunctions.
Data monitor	Receives input/output signals from the BCM and indicates and stores them to facilitate locating the causes of malfunctions.
Active test	Transmits command to the BCM to change output signals and check operation of output system.

WORK SUPPORT MODE

Refer to [WT-23, "Work Procedure"](#).

SELF-DIAG RESULTS MODE

Refer to [BCS-137, "DTC Index"](#).

DATA MONITOR MODE

Screen of data monitor mode is displayed.

NOTE:

When malfunction is detected, CONSULT-III perform REAL-TIME DIAGNOSIS. Also, any malfunction detected while in this mode will be displayed at real time.

Monitor item (Unit)	Remark
AIR PRESS FL (kPa), (kg/cm ²), (Psi)	Air pressure of tires
AIR PRESS FR (kPa), (kg/cm ²), (Psi)	
AIR PRESS RR (kPa), (kg/cm ²), (Psi)	
AIR PRESS RL (kPa), (kg/cm ²), (Psi)	
ID REGST FL1	ID is registered: Done ID is not registered: Yet
ID REGST FR1	
ID REGST RR1	
ID REGST RL1	
WARNING LAMP	Low tire pressure warning lamp ON: On Low tire pressure warning lamp OFF: Off
BUZZER	Combination meter buzzer ON: On Combination meter buzzer OFF: Off

NOTE:

Before performing the self-diagnosis, be sure to register the ID, or erase the actual malfunction location may be different from that displayed on CONSULT-III.

ACTIVE TEST MODE

NOTE:

Before performing the self-diagnosis, be sure to register the ID, or erase the actual malfunction may be different from that displayed on CONSULT-III.

TEST ITEM LIST

DIAGNOSIS SYSTEM (BCM) (WITHOUT INTELLIGENT KEY SYSTEM)

< SYSTEM DESCRIPTION >

[REGULAR GRADE]

Test item	Content
WARNING LAMP	This test is able to check to check that the low tire pressure warning lamp turns on.
ID REGIST WARNING	This test is able to check to check that the buzzer sounds or the low tire pressure warning lamp turns on.
RUN FLAT TIRE W/L	NOTE: This item is displayed, but cannot be use this item.
FLASHER	This test is able to check to check that each turn signal lamp turns on.
HORN	This test is able to check to check that the horn sounds.

ECU DIAGNOSIS INFORMATION

BCM

WITH INTELLIGENT KEY

WITH INTELLIGENT KEY : List of ECU Reference

INFOID:0000000006504207

ECU	Reference
BCM	BCS-47, "Reference Value"
	BCS-71, "Fail-safe"
	BCS-72, "DTC Inspection Priority Chart"
	BCS-73, "DTC Index"

WITHOUT INTELLIGENT KEY

WITHOUT INTELLIGENT KEY : List of ECU Reference

INFOID:0000000006504208

ECU	Reference
BCM	BCS-119, "Reference Value"
	BCS-136, "Fail-safe"
	BCS-137, "DTC Inspection Priority Chart"
	BCS-137, "DTC Index"

A
B
C
D
WT
F
G
H
I
J
K
L
M
N
O
P

TIRE PRESSURE MONITORING SYSTEM

< WIRING DIAGRAM >

[REGULAR GRADE]

WIRING DIAGRAM

TIRE PRESSURE MONITORING SYSTEM

Wiring Diagram

INFOID:000000006504209

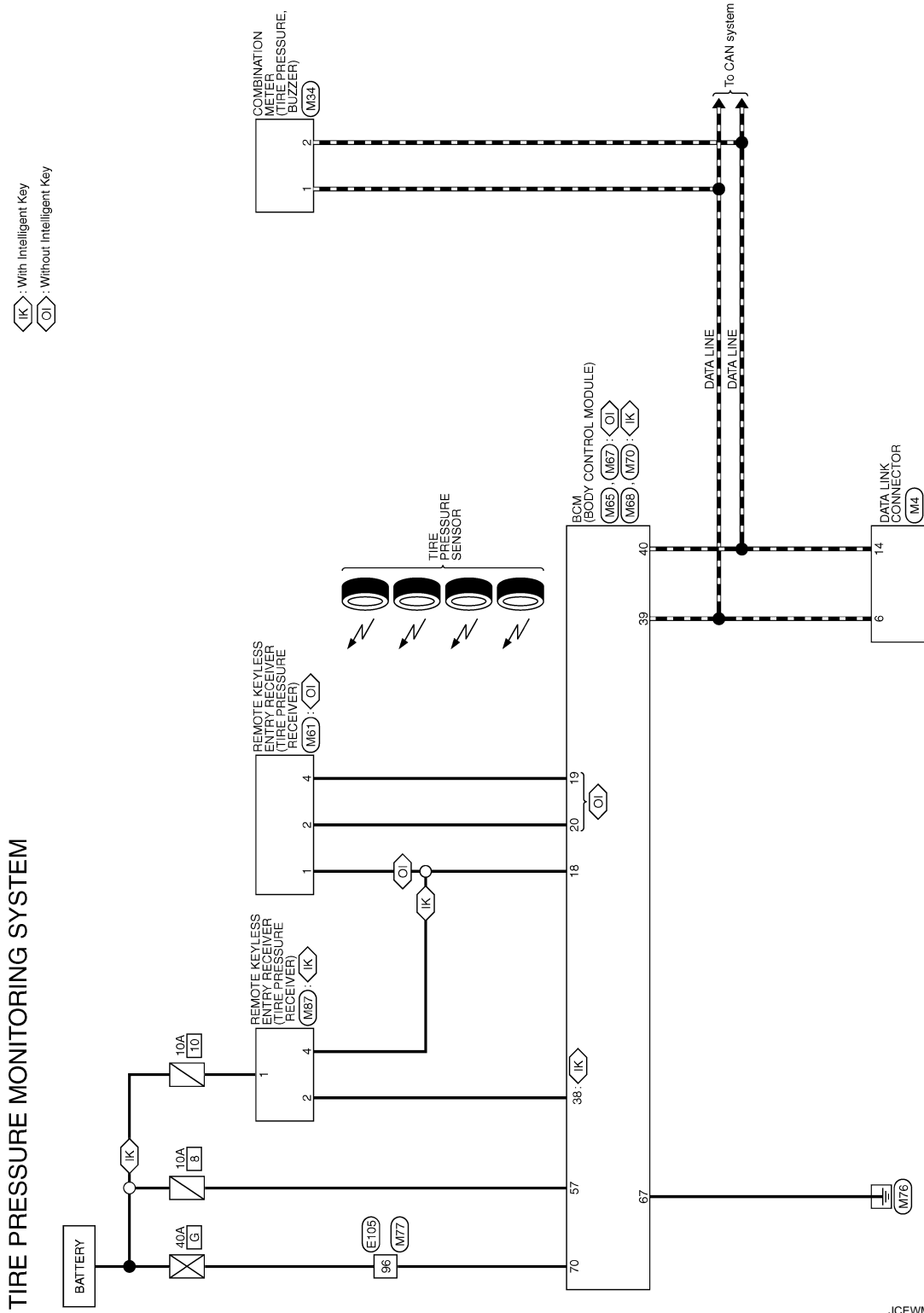

TIRE PRESSURE MONITORING SYSTEM

< WIRING DIAGRAM >

[REGULAR GRADE]

TIRE PRESSURE MONITORING SYSTEM

Connector No.	E102
Connector Name	WIRE TO WIRE
Connector Type	TH80M/2S16-TM4



Terminal No.	Color of Wire	Signal Name [Specification]
1	V	-
2	W	-
3	SB	-
4	G	-
5	P	-
6	L	- [With NAVI]
7	Y	- [Without NAVI]
8	O	-
9	W	-
10	SB	-
31	V	-
32	R	-
33	GR	-
34	P	-
35	Y	-
36	BR	-
39	SB	-
44	R	-
45	V	-
46	P	-
46	L	-
51	BR	- [With CVT]
51	B	- [With M/T]
53	SB	-
54	W	- [With CVT]
54	O	- [With M/T]
54	O	-
57	LG	-
59	L	-
60	O	-
61	G	-
62	W	-
63	L	-
67	GR	- [With CVT]
67	V	- [With M/T]
69	P	-
70	SHIELD	-
71	GR	-

72	LG	-
73	P	-
74	V	-
76	Y	-
77	LG	-
78	O	-
79	G	-
80	P	-
81	L	-
82	W	-
83	BR	-
84	B	-
87	GR	-
91	W	-
92	Y	-
93	Y	-
94	R	-
95	V	-
96	LG	-
97	R	-
98	SB	-
99	G	-
100	P	-

Connector No.	M4
Connector Name	DATA LINK CONNECTOR
Connector Type	BD16FW

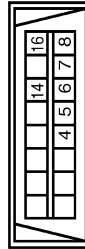

Terminal No.	Color of Wire	Signal Name [Specification]
4	B	-
5	B	-
6	L	-
7	GR/R	-
8	O	-
14	P	-
16	LG/R	-

Connector No.	M34
Connector Name	COMBINATION METER
Connector Type	TH40FW-MH



Terminal No.	Color of Wire	Signal Name [Specification]
1	L	CAN-H
2	P	CAN-L
3	V	VEHICLE SPEED SIGNAL (2-PULSE)
4	L	VEHICLE SPEED SIGNAL (8-PULSE)
6	BR/Y	FUEL LEVEL SENSOR SIGNAL
7	R/G	AIR BAG SIGNAL
8	P	OVERDRIVE CONTROL SWITCH SIGNAL
9	O	SEAT BELT BUCKLE SWITCH SIGNAL (DRIVER SIDE)
10	SB	PARKING BRAKE SWITCH SIGNAL
11	G/R	BRAKE FLUID LEVEL SWITCH SIGNAL
13	B/R	ILLUMINATION CONTROL SIGNAL
15	L/Y	ACC POWER SUPPLY
17	G	WASHER LEVEL SWITCH SIGNAL
18	R/Y	SECURITY SIGNAL
19	V/W	AMBIENT SENSOR SIGNAL
20	R/W	AMBIENT SENSOR GROUND
21	B	GROUND
22	B	GROUND
23	B	GROUND
24	V	FUEL LEVEL SENSOR GROUND
25	B	VDC GROUND
27	LG	BATTERY POWER SUPPLY
28	GR	IGNITION SIGNAL
29	BR	PASSENGER SEAT BELT WARNING SIGNAL
31	R	A/C AUTO AMP CONNECTION RECOGNITION SIGNAL
35	BR	ENGINE COOLANT TEMPERATURE SIGNAL
38	GR	ALTERNATOR SIGNAL

Connector No.	M61
Connector Name	REMOTE KEYLESS ENTRY RECEIVER
Connector Type	TK04FW



Terminal No.	Color of Wire	Signal Name [Specification]
1	V	-
2	G/Y	-
4	BR	-

A
B
C
D
WT
F
G
H
I
J
K
L
M
N
O
P

TIRE PRESSURE MONITORING SYSTEM

< WIRING DIAGRAM >

[REGULAR GRADE]

TIRE PRESSURE MONITORING SYSTEM

Connector No.	M65
Connector Name	BCM (BODY CONTROL MODULE)
Connector Type	TH40FTV-NH



1	2	3	4	5	6	7	8	9	10	11	12	13	14	15	16	17	18	19	20	21	22	23	24	25	26	27	28	29	30
---	---	---	---	---	---	---	---	---	----	----	----	----	----	----	----	----	----	----	----	----	----	----	----	----	----	----	----	----	----

Terminal No.	Color of Wire	Signal Name [Specification]
2	BR/W	COMBI SW INPUT 5
3	GR	COMBI SW INPUT 4
4	L/Y	COMBI SW INPUT 3
5	G	COMBI SW INPUT 2
6	L/R	COMBI SW INPUT 1
7	W/R	KEY CYL UNLOCK SW
8	W/B	KEY CYL LOCK SW
9	R	STOP LAMP SW
10	W/L	REAR WINDOW DEFROGGER SW
11	L/Y	ACC
12	SB	PASSENGER DOOR SW
13	GR/L	REAR RH DOOR SW
14	L/B	OPTICAL SENSOR
17	R/G	OPTICAL SENSOR POWER SUPPLY
18	V	RECEIVER / SENSOR GND
19	BR	KEYLESS ENTRY RECEIVER POWER SUPPLY
20	G/Y	KEYLESS ENTRY RECEIVER COMM
21	P/L	NATS ANTENNA AMP
23	R/Y	SECURITY INDICATOR LAMP
24	GR/R	DOGGLE LINK
25	LG	NATS ANTENNA AMP
26	GR	THERMO CONTROL AMP
27	V/G	A/C SW (With reset A/C)
27	Y/R	A/C SW (With reset A/C)
28	G/W	BLOWER FAN SW
29	L/W	HAZARD SW
31	G/Y	FR DEFROSTER SW
32	LG	COMBI SW OUTPUT 5
33	Y/L	COMBI SW OUTPUT 4
34	W	COMBI SW OUTPUT 3
35	R/L	COMBI SW OUTPUT 2
36	L/O	COMBI SW OUTPUT 1
37	R/W	KEY SWITCH
38	O	IGN
39	L	CAN-H
40	P	CAN-L

Connector No.	M67
Connector Name	BCM (BODY CONTROL MODULE)
Connector Type	FEA09FB-FHA6-SA



56	57	58	59	60	61	62	63	64	65	66	67	68	69	70
----	----	----	----	----	----	----	----	----	----	----	----	----	----	----

Terminal No.	Color of Wire	Signal Name [Specification]
56	L	INTERIOR ROOM LAMP POWER SUPPLY
57	Y	BAT (FUSE)
59	L/B	DRIVER DOOR UNLOCK OUTPUT
60	W/B	TURN SIGNAL LH OUTPUT
61	W/L	TURN SIGNAL RH OUTPUT
63	BR	ROOM LAMP TIMER CONTROL
65	V	ALL DOOR LOCK OUTPUT
66	G	PASSENGER DOOR REAR DOOR UNLOCK OUTPUT
67	B	GND
68	L	POWER WINDOW POWER SUPPLY (IGN)
68	L/W	POWER WINDOW POWER SUPPLY (BAT)
70	Y	BAT (F/L)

Connector No.	M68
Connector Name	BCM (BODY CONTROL MODULE)
Connector Type	TH40FB-NH



1	2	3	4	5	6	7	8	9	10	11	12	13	14	15	16	17	18	19	20	21	22	23	24	25	26	27	28	29	30	31	32	33	34	35	36	37	38	39	40
---	---	---	---	---	---	---	---	---	----	----	----	----	----	----	----	----	----	----	----	----	----	----	----	----	----	----	----	----	----	----	----	----	----	----	----	----	----	----	----

Terminal No.	Color of Wire	Signal Name [Specification]
2	BR/W	COMBI SW INPUT 5
3	GR	COMBI SW INPUT 4
4	L/Y	COMBI SW INPUT 3
5	G	COMBI SW INPUT 2
6	L/R	COMBI SW INPUT 1
7	W/R	KEY CYL UNLOCK SW
8	W/B	KEY CYL LOCK SW
9	R	STOP LAMP SW 1
12	GR	CENTRAL DOOR LOCK SW
13	BR	CENTRAL DOOR UNLOCK SW

Terminal No.	Color of Wire	Signal Name [Specification]
14	L/B	OPTICAL SENSOR
15	W/L	REAR WINDOW DEFROGGER SW
17	R/G	OPTICAL SENSOR POWER SUPPLY
18	V	SENSOR GND
21	P/L	NATS ANTENNA AMP
23	R/Y	SECURITY INDICATOR LAMP
24	GR/R	DOGGLE LINK
25	LG	NATS ANTENNA AMP
27	Y/G	A/C SW
28	G/W	BLOWER FAN SW
29	L/W	HAZARD SW
31	G/B	DR DOOR UNLOCK SENSOR
32	LG	COMBI SW OUTPUT 5
33	Y/L	COMBI SW OUTPUT 4
34	W	COMBI SW OUTPUT 3
35	R/L	COMBI SW OUTPUT 2
36	L/O	COMBI SW OUTPUT 1
37	G/O	SHIFT P
38	G/Y	RECEIVER COMM
39	L	CAN-H
40	P	CAN-L

Connector No.	M70
Connector Name	BCM (BODY CONTROL MODULE)
Connector Type	FEA09FW-FHA6-SA



56	57	58	59	60	61	62	63	64	65	66	67	68	69	70
----	----	----	----	----	----	----	----	----	----	----	----	----	----	----

Terminal No.	Color of Wire	Signal Name [Specification]
56	L	INTERIOR ROOM LAMP POWER SUPPLY
57	Y	BAT (FUSE)
59	G	PASSENGER DOOR UNLOCK OUTPUT
60	W/B	TURN SIGNAL LH OUTPUT
61	W/L	TURN SIGNAL RH OUTPUT
63	BR	ROOM LAMP TIMER CONTROL
65	V	ALL DOOR LOCK OUTPUT
66	L/B	DRIVER DOOR UNLOCK OUTPUT
67	B	GND
68	L	POWER WINDOW POWER SUPPLY (IGN)
69	L/W	POWER WINDOW POWER SUPPLY (BAT)
70	Y	BAT (F/L)

TIRE PRESSURE MONITORING SYSTEM

< WIRING DIAGRAM >

[REGULAR GRADE]

A
B
C
D
WT
F
G
H
I
J
K
L
M
N
O
P

TIRE PRESSURE MONITORING SYSTEM

Connector No.	M77
Connector Name	WIRE TO WIRE
Connector Type	TH80FY-CS16-TM4

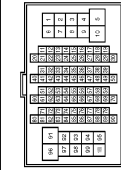

Terminal No.	Color of Wire	Signal Name [Specification]
1	B/O	
2	R	
3	G/R	
4	G/B	
5	L	
6	L	
7	W/R	
8	G/W	
9	Y/L	
10	W	
11	GR/L	
12	L/B	
13	R/Y	
14	SB	
15	BR	
16	G	
17	L/R	
18	G/O	
19	LG/R	
20	GR/W	
21	L/O	
22	B/W	
23	R/L	
24	O	
25	GR	
26	V	
27	R/W	
28	V/W	
29	W/L	
30	W/B	
31	Y/R	
32	LG	
33	SHIELD	
34	P/B	
35	R/G	
36	R	
37	L/Y	
38	W/G	

77	GR/R	--
78	O	--
79	LG	--
80	P	--
81	L	--
82	GR	--
83	G/R	--
84	B	--
87	G	--
91	R	--
92	O	--
93	Y	--
94	R/B	--
95	L/W	--
96	Y	--
97	L	--
98	BR/W	--
99	W	--
100	G/R	--

Connector No.	M87
Connector Name	REMOTE KEYLESS ENTRY RECEIVER
Connector Type	TH04FY-NH



Terminal No.	Color of Wire	Signal Name [Specification]
1	BR	POWER
2	G/Y	SIGNAL
4	V	GND

JCEWM0278GB

BASIC INSPECTION

DIAGNOSIS AND REPAIR WORK FLOW

Work Flow

INFOID:000000006504210

DETAILED FLOW

1. COLLECT THE INFORMATION FROM THE CUSTOMER

It is also important to clarify customer concerns before starting the inspection. Reproduce the symptom, and understand it fully. Interview the customer about the concerns carefully. In some cases, it is necessary to check the symptoms by driving the vehicle with the customer.

CAUTION:

Customers are not professionals. Never assume “maybe the customer means...” or “maybe the customer mentioned this symptom.”

>> GO TO 2.

2. BASIC INSPECTION

1. Turn the ignition switch ON.

CAUTION:

Never start the engine.

2. Check the tire pressure for all wheels and adjust to the specified value. Refer to [WT-53, "Tire Air Pressure"](#).

Is the inspection result normal?

YES >> GO TO 3.

NO >> Inspect or repair the tires or wheels.

3. CHECK LOW TIRE PRESSURE WARNING LAMP

Check low tire pressure warning lamp display.

Does not low tire pressure warning lamp turn OFF?

YES >> GO TO 4.

NO >> INSPECTION END

4. CRUISE TEST

Start the engine and drive the vehicle.

>> GO TO 5.

5. PERFORM SELF-DIAGNOSIS

 **With CONSULT-III**

Perform “SELF-DIAG RESULTS” in “AIR PRESSURE MONITOR” of “BCM”.

Is any DTC detected?

YES >> GO TO 7.

NO >> GO TO 6.

6. CHECK SYMPTOM

Perform trouble diagnosis for the applicable symptom. Refer to [WT-35, "Symptom Table"](#).

Is the cause of the malfunction detected?

YES >> GO TO 8.

NO >> GO TO 10.

7. CIRCUIT DIAGNOSIS

Inspect the malfunctioning system indicated by the DTC code that is detected during self-diagnosis. Refer to [BCS-73, "DTC Index"](#) (With intelligent key system), [BCS-137, "DTC Index"](#) (Without intelligent key system).

>> GO TO 8.

DIAGNOSIS AND REPAIR WORK FLOW

< BASIC INSPECTION >

[REGULAR GRADE]

8.REPAIR WORK

Repair or replace the malfunctioning part.

>> GO TO 9.

9.PERFORM SELF-DIAGNOSIS

1. Select "SELF-DIAG RESULTS" in "AIR PRESSURE MONITOR" of "BCM".
2. Touch "ERASE" on CONSULT-III screen to erase memory.
3. Drive the vehicle.
4. Perform "SELF-DIAG RESULTS" in "AIR PRESSURE MONITOR" of "BCM".

Is any DTC detected?

- YES >> GO TO 7.
NO >> GO TO 10.

10.FINAL CHECK

1. Perform a cruise test.
2. Check that the low tire pressure warning lamp turn OFF.

Dose the tire pressure warning lamp turn OFF?

- YES >> INSPECTION END
NO >> GO TO 2.

A
B
C
D
WT
F
G
H
I
J
K
L
M
N
O
P

TRANSMITTER WAKE UP OPERATION

< BASIC INSPECTION >

[REGULAR GRADE]

TRANSMITTER WAKE UP OPERATION

Description

INFOID:000000006504211

This procedure must be done after replacement of a transmitter, BCM, or rotation of wheels.

Work Procedure

INFOID:000000006504212

1. TRANSMITTER WAKE-UP PROCEDURE

1. Turn the ignition switch ON.

CAUTION:

Never start the engine.

NOTE:

The position of an inactive transmitter can be identified by checking the blinking timing of the low tire pressure warning lamp.

Low tire pressure warning lamp blinking timing		Activation tire position
ON OFF		a : 0.3 sec. b : 1.0 sec. Front LH
ON OFF		a : 0.3 sec. b : 1.0 sec. Front RH
ON OFF		a : 0.3 sec. b : 1.0 sec. Rear RH
ON OFF		a : 0.3 sec. b : 1.0 sec. Rear LH
ON OFF		a : 2 sec. b : 0.2 sec. All tires

JPEIC0089GB

2. Contact the activation tool (J-45295) (1) to the side of the tire at the location to the transmitter.
3. Press and hold the activation tool button while pushing the tool to the tire surface. (approximately for 5 seconds)

CAUTION:

Perform the wake-up procedure starting from the vehicle front left wheel, then repeat the procedure in the order of the front right wheel, rear right wheel, and rear left wheel.

4. Check that the turn signal lamps blink twice when the transmitter wake-up procedure for all wheels is completed.
5. Check that the low tire pressure warning lamp turns OFF, after the transmitter wake-up procedure is completed for all wheels and turns OFF.

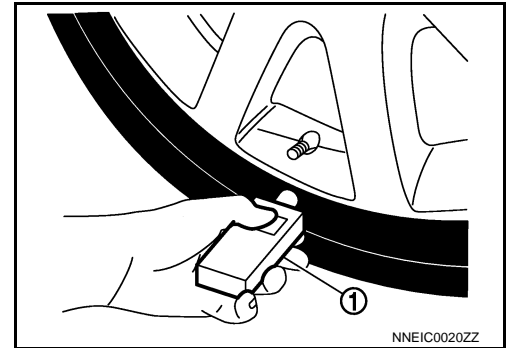

NNEIC0020ZZ

Is the transmitter wake-up procedure completed?

- YES >> Perform the transmitter ID registration procedure. Refer to [WT-23, "Work Procedure"](#).
 NO >> Perform trouble diagnosis for the transmitter. Refer to [WT-27, "Diagnosis Procedure"](#).

ID REGISTRATION PROCEDURE

< BASIC INSPECTION >

[REGULAR GRADE]

ID REGISTRATION PROCEDURE

Description

INFOID:000000006504213

This procedure must be done after replacing or rotating wheels, replacing transmitter or BCM.

Work Procedure

INFOID:000000006504214

1. TRANSMITTER ID REGISTRATION PROCEDURE

Ⓜ With CONSULT-III.

1. Display the "WORK SUPPORT" screen and select "ID REGIST".

Is the activation tool (J-45295) used for the transmitter ID registration procedure?

YES >> GO TO 2.

NO >> GO TO 3.

2. TRANSMITTER ID REGISTRATION PROCEDURE (WITH ACTIVATION TOOL)

1. Turn the ignition switch ON.
2. Select the start button on the "ID REGIST" screen.
3. Contact the activation tool (J-45295) (1) to the side of the tire at the location to the transmitter.
4. Press and hold the activation tool button while pushing the tool to the tire surface. (approximately for 5 seconds)

CAUTION:

Perform the ID registration procedure starting from the vehicle front left wheel, then repeat the procedure in the order of the front right wheel, rear right wheel, and rear left wheel.

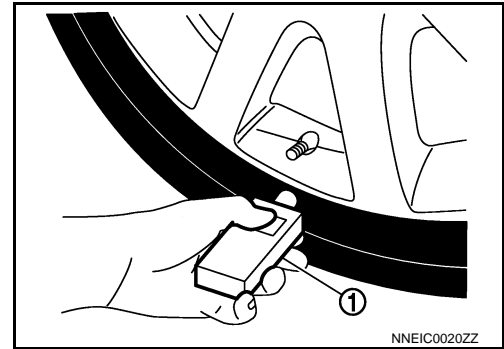

5. When ID registration is completed, check the following pattern at each wheel.

Se-quence	ID registration position	Turn signal lamp	CONSULT-III
1	Front left wheel	2 blinks	"Red" ↓ "Green"
2	Front right wheel		
3	Rear right wheel		
4	Rear left wheel		

6. After the ID registration procedure for all wheels is completed, press "END" to end ID registration, and check that ID registration for all wheels is completed.

Is the check result normal?

YES >> ID registration END.

NO >> Performs trouble-diagnosis of the Tire Pressure Monitoring System (TPMS). Refer to [BCS-73, "DTC Index"](#) (With intelligent key system), [BCS-137, "DTC Index"](#) (Without intelligent key system).

3. TRANSMITTER ID REGISTRATION PROCEDURE (WITHOUT ACTIVATION TOOL)

1. Adjust the tire pressure for all wheels to match the list below.

Tire position	Tire pressure kPa (kg/cm ² , psi)
Front LH	240 (2.4, 35)
Front RH	220 (2.2, 32)
Rear RH	200 (2.0, 29)
Rear LH	180 (1.8, 26)

ID REGISTRATION PROCEDURE

< BASIC INSPECTION >

[REGULAR GRADE]

2. Drive the vehicle at a speed at more than 40 km/h (25 MPH) for 3 minutes or more, then perform the transmitter ID registration procedure.
3. After ID registration for all wheels is completed, press "END" to end ID registration.

ID registration position	CONSULT-III
Front LH	"Red" ↓ "Green"
Front RH	
Rear RH	
Rear LH	

4. Adjust the tire pressures for all wheels to the specified value. Refer to [WT-53, "Tire Air Pressure"](#).

Is ID registrations for all wheels completed?

YES >> ID registration END.

NO >> Performs trouble-diagnosis of the Tire Pressure Monitoring System (TPMS). Refer to [BCS-73, "DTC Index"](#) (With intelligent key system), [BCS-137, "DTC Index"](#) (Without intelligent key system).

C1704, C1705, C1706, C1707 LOW TIRE PRESSURE

< DTC/CIRCUIT DIAGNOSIS >

[REGULAR GRADE]

DTC/CIRCUIT DIAGNOSIS

C1704, C1705, C1706, C1707 LOW TIRE PRESSURE

Description

INFOID:000000006504215

When the tire pressure monitoring system detects low inflation pressure, the low tire pressure warning lamps in the combination meter comes on.

DTC Logic

INFOID:000000006504216

DTC DETECTION LOGIC

DTC	Display item	Malfunction detected condition	Possible cause
C1704	LOW PRESSURE FL	Front LH tire pressure drops to 182.7 kPa (1.9 kg/cm ² , 26 psi) or less. [NOTE]	<ul style="list-style-type: none">• Low tire pressure• Transmitter malfunction
C1705	LOW PRESSURE FR	Front RH tire pressure drops to 182.7 kPa (1.9 kg/cm ² , 26 psi) or less. [NOTE]	
C1706	LOW PRESSURE RR	Rear RH tire pressure drops to 182.7 kPa (1.9 kg/cm ² , 26 psi) or less. [NOTE]	
C1707	LOW PRESSURE RL	Rear LH tire pressure drops to 182.7 kPa (1.9 kg/cm ² , 26 psi) or less. [NOTE]	

DTC CONFIRMATION PROCEDURE

1. DTC REPRODUCTION PROCEDURE

Ⓜ With CONSULT-III

1. Turn the ignition switch ON.

CAUTION:

Never start the engine.

2. Check the tire pressure for all wheels and adjust to the specified value. Refer to [WT-53, "Tire Air Pressure"](#).
3. Perform "SELF-DIAG RESULTS" in "AIR PRESSURE MONITOR" of "BCM".

Is DTC "C1704", "C1705", "C1706", "C1707" detected?

- YES >> Perform trouble diagnosis. Refer to [WT-25, "Diagnosis Procedure"](#).
NO >> INSPECTION END

Diagnosis Procedure

INFOID:000000006504217

1. CHECK TIRE PRESSURE

Check the internal pressure of all wheels. Refer to [WT-53, "Tire Air Pressure"](#).

Is the inspection result normal?

- YES >> Replace the DTC-detected malfunctioning transmitter. Refer to [WT-47, "WITH INTELLIGENT KEY : Removal and Installation"](#) (With intelligent key system), [WT-50, "WITHOUT INTELLIGENT KEY : Removal and Installation"](#) (Without intelligent key system).
NO >> After adjusting the air pressure, GO TO 2.

2. CHECK TIRE PRESSURE SIGNAL

Ⓜ With CONSULT-III

1. Drive for 3 minutes at a speed of 40 km/h (25 MPH) or more, then drive normally for 10 minutes.
2. Perform "DATA MONITOR" in "AIR PRESSURE MONITOR" of "BCM".
3. Select "BCM" in "DATA MONITOR", and check that the tire pressures match the standard value.

C1704, C1705, C1706, C1707 LOW TIRE PRESSURE

< DTC/CIRCUIT DIAGNOSIS >

[REGULAR GRADE]

Monitor item	Condition	Displayed value
AIR PRESS FL	Drive for 3 minutes at a speed of 40 km/h (25 MPH) or more, then drive normally for 10 minutes.	Internal pressure of tires
AIR PRESS FR		
AIR PRESS RR		
AIR PRESS RL		

CAUTION:

Stop the vehicle and within 5 minutes, use “DATA MONITOR” in “AIR PRESSURE MONITOR” of “BCM” to display the tire pressure for all wheels.

Is the inspection result normal?

YES >> Inspect or repair the tires or wheels and adjust the tire pressure to the specification.

NO >> GO TO 1.

Special Repair Requirement

INFOID:000000006504218

1.CHECK TIRE PRESSURE

Check all tires for tire pressures. Refer to [WT-53, "Tire Air Pressure"](#).

Does all tire pressure data meet the specification?

YES >> GO TO 2.

NO >> Inspect or repair the tires or wheels and adjust the tire pressure to the specification.

2.PERFORM ID REGISTRATION

Perform ID registration. Refer to [WT-23, "Work Procedure"](#).

>> END

C1708, C1709, C1710, C1711 TRANSMITTER

< DTC/CIRCUIT DIAGNOSIS >

[REGULAR GRADE]

C1708, C1709, C1710, C1711 TRANSMITTER

DTC Logic

INFOID:000000006504219

DTC DETECTION LOGIC

DTC	Display Item	Malfunction detected condition	Possible causes
C1708	[NO DATA] FL	Tire pressure data signal from the front LH wheel tire pressure sensor cannot be detected.	<ul style="list-style-type: none">• Harness or connector (Tire pressure receiver, BCM)• Transmitter ID registration incomplete• Transmitter• Transmitter battery voltage• Driving in area where radio wave cannot be transmitted/received.
C1709	[NO DATA] FR	Tire pressure data signal from the front RH wheel tire pressure sensor cannot be detected.	
C1710	[NO DATA] RR	Tire pressure data signal from the rear RH wheel tire pressure sensor cannot be detected.	
C1711	[NO DATA] RL	Tire pressure data signal from the rear LH wheel tire pressure sensor cannot be detected.	

DTC CONFIRMATION PROCEDURE

1. TIRE PRESSURE SENSOR ID REGISTRATION

Perform tire pressure sensor ID registration. Refer to [WT-23. "Work Procedure"](#).

>> GO TO 2.

2. PERFORM DTC CONFIRMATION

With CONSULT-III

1. Drive the vehicle at 40 km/h or more for 10 minutes.

CAUTION:

Total time driving at a speed of 40 km/h or more must be 10 minutes.

NOTE:

Avoid driving in area where radio wave cannot be transmitted/received.

2. Stop the vehicle.
3. Perform self-diagnosis for "AIR PRESSURE MONITOR" of "BCM".

Is DTC "C1708", "C1709", "C1710" or "C1711" detected?

YES >> Proceed to [WT-27. "Diagnosis Procedure"](#).

NO >> INSPECTION END

Diagnosis Procedure

INFOID:000000006935266

1. CHECK TIRE PRESSURE SIGNAL

With CONSULT-III

1. Select "DATA MONITOR" in "AIR PRESSURE MONITOR" of "BCM".
2. Check the values that are displayed for "AIR PRESS FL", "AIR PRESS FR", "AIR PRESS RR", and "AIR PRESS RL".

Are all tire pressures displayed 0 kPa (psi)?

YES (With intelligent key system)>>GO TO 2.

YES (Without intelligent key system)>>GO TO 4.

NO >> Replace applicable transmitter. Refer to [WT-47. "WITH INTELLIGENT KEY : Removal and Installation"](#) (With intelligent key system), [WT-50. "WITHOUT INTELLIGENT KEY : Removal and Installation"](#) (Without intelligent key system).

2. CHECK RECEIVER CIRCUIT

1. Turn the ignition switch OFF.
2. Check 10A fuse (#10).

CAUTION:

Check that the fuse is not blown, that there are no other abnormalities, and that the fuse is of the specified capacity.

3. Disconnect BCM harness connector and tire pressure receiver harness connector.

C1708, C1709, C1710, C1711 TRANSMITTER

< DTC/CIRCUIT DIAGNOSIS >

[REGULAR GRADE]

4. Check the continuity between BCM harness connector and tire pressure receiver harness connector.

BCM		Tire pressure receiver		Continuity
Connector	Terminal	Connector	Terminal	
M68	18	M87	4	Existed
	38		2	

5. Check the continuity between BCM harness connector and ground.

BCM		—	Continuity
Connector	Terminal		
M68	18	Ground	Not existed
	38		

Is the inspection result normal?

YES >> GO TO 3.

NO >> Repair or replace error-detected parts.

3. CHECK TIRE PRESSURE RECEIVER POWER SUPPLY CIRCUIT

1. Connect tire pressure receiver harness connector.
2. Check the voltage between tire pressure receiver harness connector and the ground when the ignition switch is turned ON and OFF.

CAUTION:

Never start the engine.

Tire pressure receiver		—	Voltage
Connector	Terminal		
R87	1	Ground	9 – 16 V

Is the inspection result normal?

YES >> GO TO 6.

NO >> Repair or replace error-detected parts.

4. CHECK RECEIVER CIRCUIT

1. Turn the ignition switch OFF.
2. Disconnect BCM harness connector and tire pressure receiver harness connector.
3. Check the continuity between BCM harness connector and tire pressure receiver harness connector.

BCM		Tire pressure receiver		Continuity
Connector	Terminal	Connector	Terminal	
M65	18	R61	1	Existed
	19		4	
	20		2	

4. Check the continuity between BCM harness connector and ground.

BCM		—	Continuity
Connector	Terminal		
M65	18	Ground	Not existed
	19		
	20		

Is the inspection result normal?

YES >> GO TO 5.

NO >> Repair or replace error-detected parts.

5. CHECK TIRE PRESSURE RECEIVER POWER SUPPLY CIRCUIT

C1708, C1709, C1710, C1711 TRANSMITTER

< DTC/CIRCUIT DIAGNOSIS >

[REGULAR GRADE]

1. Connect tire pressure receiver harness connector.
2. Check the voltage between tire pressure receiver harness connector and the ground when the ignition switch is turned ON and OFF.

CAUTION:

Never start the engine.

Tire pressure receiver		—	Voltage
Connector	Terminal		
R61	1	Ground	9 – 16 V

Is the inspection result normal?

- YES >> GO TO 6.
- NO >> Replace the BCM.

6.CHECK TIRE PRESSURE SIGNAL

Check the function tire pressure receiver. Refer to [DLK-75. "Component Function Check"](#) (With intelligent key system), [DLK-270. "Wiring Diagram - REMOTE KEYLESS ENTRY SYSTEM -"](#) (Without intelligent key system).

Is the inspection result normal?

- YES >> Replace the BCM.
- NO >> Repair or replace error-detected parts.

Special Repair Requirement

INFOID:000000006968091

1.CHECK TIRE PRESSURE

Check all tires for tire pressures. Refer to [WT-53. "Tire Air Pressure"](#).

Does all tire pressure data meet the specification?

- YES >> GO TO 2.
- NO >> Inspect or repair the tires or wheels and adjust the tire pressure to the specification.

2.PERFORM ID REGISTRATION

Perform ID registration. Refer to [WT-23. "Work Procedure"](#).

>> END

C1716, C1717, C1718, C1719 TRANSMITTER

< DTC/CIRCUIT DIAGNOSIS >

[REGULAR GRADE]

C1716, C1717, C1718, C1719 TRANSMITTER

DTC Logic

INFOID:000000006504222

DTC DETECTION LOGIC

DTC	Display item	Malfunction detected condition	Possible case
C1716	[PRESSDATA ERR] FL	Malfunction in the tire pressure data from the front left wheel transmitter.	<ul style="list-style-type: none">• Excessive tire pressure• ID registration is not finished• Transmitter malfunction
C1717	[PRESSDATA ERR] FR	Malfunction in the tire pressure data from the front right wheel transmitter.	
C1718	[PRESSDATA ERR] RR	Malfunction in the tire pressure data from the rear right wheel transmitter.	
C1719	[PRESSDATA ERR] RL	Malfunction in the tire pressure data from the rear left wheel transmitter.	

DTC CONFIRMATION PROCEDURE

1. DTC REPRODUCTION PROCEDURE

Ⓜ With CONSULT-III

1. Turn the ignition switch ON.

CAUTION:

Never start the engine.

2. Check the tire pressure for all wheels and adjust to the specified value. Refer to [WT-53, "Tire Air Pressure"](#).
3. Perform "SELF-DIAG RESULTS" in "AIR PRESSURE MONITOR" of "BCM".

Is DTC "C1716", "C1717", "C1718", "C1719" detected?

- YES >> Perform trouble diagnosis. Refer to [WT-30, "Diagnosis Procedure"](#).
NO >> INSPECTION END

Diagnosis Procedure

INFOID:000000006504223

1. CHECK TIRE PRESSURE

Check the internal pressure of all wheels. Refer to [WT-53, "Tire Air Pressure"](#).

Is the inspection result normal?

- YES >> Replace the DTC-detected malfunctioning transmitter. Refer to [WT-47, "WITH INTELLIGENT KEY : Removal and Installation"](#) (With intelligent key system), [WT-50, "WITHOUT INTELLIGENT KEY : Removal and Installation"](#) (Without intelligent key system).
NO >> After adjusting the tire pressure, GO TO 2.

2. CHECK TIRE PRESSURE SIGNAL

Ⓜ With CONSULT-III

1. Check and adjust the tire pressure for all wheels. Refer to [WT-53, "Tire Air Pressure"](#).
2. Perform transmitter ID registration for all wheels. Refer to [WT-23, "Work Procedure"](#).
3. Drive for 3 minutes at a speed of 40 km/h (25 MPH) or more, then drive normally for 10 minutes.
4. Perform "DATA MONITOR" in "AIR PRESSURE MONITOR" of "BCM".
5. Select "BCM" in "DATA MONITOR", and check that the tire pressures match the standard value.

CAUTION:

Stop the vehicle and within 15 minutes, use CONSULT-III "DATA MONITOR" to display the tire pressure for all wheels.

6. Check that "DATA MONITOR" displays tire pressure of 438.60 kPa (4.47 kg/cm², 63.60 Psi).

Is the inspection 438.60 kPa (4.47 kg/cm², 63.60 Psi)?

- YES >> Replace transmitter the tire pressure 438.60 kPa (4.386 bar, 4.47 kg/cm², 63.60 Psi) displayed. Refer to [WT-47, "WITH INTELLIGENT KEY : Removal and Installation"](#) (With intelligent key system), [WT-50, "WITHOUT INTELLIGENT KEY : Removal and Installation"](#) (Without intelligent key system).
NO >> GO TO 1.

C1716, C1717, C1718, C1719 TRANSMITTER

< DTC/CIRCUIT DIAGNOSIS >

[REGULAR GRADE]

Special Repair Requirement

INFOID:000000006504224

1.CHECK TIRE PRESSURE

Check all tires for tire pressures. Refer to [WT-53, "Tire Air Pressure"](#).

Does all tire pressure data meet the specification?

YES >> GO TO 2.

NO >> Inspect or repair the tires or wheels and adjust the tire pressure to the specification.

2.PERFORM ID REGISTRATION

Perform ID registration. Refer to [WT-23, "Work Procedure"](#).

>> END

A
B
C
D
E
F
G
H
I
J
K
L
M
N
O
P

WT

C1729 VEHICLE SPEED SIGNAL

< DTC/CIRCUIT DIAGNOSIS >

[REGULAR GRADE]

C1729 VEHICLE SPEED SIGNAL

Description

INFOID:000000006504225

BCM detects no vehicle speed signal.

DTC Logic

INFOID:000000006504226

DTC DETECTION LOGIC

DTC number	Trouble diagnosis name	DTC detecting condition	Possible case
C1729	VHCL SPEED SIG ERR	Vehicle speed signal not detected.	<ul style="list-style-type: none">CAN communication errorCombination meter malfunction

DTC CONFIRMATION PROCEDURE

1. DTC REPRODUCTION PROCEDURE

Ⓟ With CONSULT-III

- Drive for several minutes at a speed of 40 km/h (25 MPH) or more, then stop the vehicle.
- Perform "SELF-DIAG RESULTS" in "AIR PRESSURE MONITOR" of "BCM".

Is DTC "C1729" detected?

- YES >> Perform trouble diagnosis. Refer to [WT-32, "Diagnosis Procedure"](#).
NO >> INSPECTION END

Diagnosis Procedure

INFOID:000000006504227

1. PERFORM COMBINATION METER SELF-DIAGNOSIS

Ⓟ With CONSULT-III

Perform "SELF-DIAG RESULTS" of "METER/M&A".

Is any DTC detected?

- YES >> Check the DTC. Refer to [MWI-63, "DTC Index"](#).
NO >> GO TO 2.

2. CHECK INFORMATION

Ⓟ With CONSULT-III

- Perform "DATA MONITOR" in "AIR PRESSURE MONITOR" of "BCM".
- Select "BCM" in "DATA MONITOR", and check the input/output values. Refer to [BCS-47, "Reference Value"](#) (With intelligent key system), [BCS-119, "Reference Value"](#) (Without intelligent key system).

Is the inspection result normal?

- YES >> Check pin terminal and connection of each harness connector for malfunctioning conditions.
NO >> Replace BCM. Refer to [BCS-78, "Exploded View"](#) (With intelligent key system), [BCS-141, "Exploded View"](#) (Without intelligent key system).

Special Repair Requirement

INFOID:000000006504228

1. CHECK TIRE PRESSURE

Check all tires for tire pressures. Refer to [WT-53, "Tire Air Pressure"](#).

Does all tire pressure data meet the specification?

- YES >> GO TO 2.
NO >> Inspect or repair the tires or wheels and adjust the tire pressure to the specification.

2. PERFORM ID REGISTRATION

Perform ID registration. Refer to [WT-23, "Work Procedure"](#).

>> END

LOW TIRE PRESSURE WARNING LAMP

< DTC/CIRCUIT DIAGNOSIS >

[REGULAR GRADE]

LOW TIRE PRESSURE WARNING LAMP

Component Function Check

INFOID:000000006504236

1. CHECK THE ILLUMINATION OF THE LOW TIRE PRESSURE WARNING LAMP

Check that the low tire pressure warning lamp is turned OFF after illuminating for approximately 1 second, when the ignition switch is turned ON.

Is the inspection result normal?

YES >> INSPECTION END

NO >> Perform trouble diagnosis. Refer to [WT-33, "Diagnosis Procedure"](#).

Diagnosis Procedure

INFOID:000000006504237

1. POWER SUPPLY AND GROUND CIRCUIT

Check power supply and ground circuit. Refer to [WT-34, "Diagnosis Procedure"](#).

Is the inspection result normal?

YES >> GO TO 2.

NO >> Repair or replace damaged parts.

2. PERFORM SELF-DIAGNOSIS

 With CONSULT-III

Perform "SELF-DIAG RESULTS" in "AIR PRESSURE MONITOR" of "BCM".

Is any DTC detected?

YES >> Check the DTC. Refer to [BCS-73, "DTC Index"](#) (With intelligent key system), [BCS-137, "DTC Index"](#) (Without intelligent key system).

NO >> GO TO 3.

3. CHECK LOW TIRE PRESSURE WARNING LAMP SIGNAL

 With CONSULT-III

1. Turn the ignition switch ON.

CAUTION:

Never start the engine.

2. Perform "DATA MONITOR" in "AIR PRESSURE MONITOR" of "BCM".

3. Select "BCM" in "DATA MONITOR", and check that the low tire pressure warning lamp is turned OFF after illuminating for approximately 1 second, when the ignition switch is turned ON.

Is the inspection result normal?

YES >> Check the combination meter. Refer to [MWI-39, "COMBINATION METER : Diagnosis Procedure"](#).

NO >> Replace the BCM. Refer to [BCS-78, "Exploded View"](#) (With intelligent key system), [BCS-141, "Exploded View"](#) (Without intelligent key system).

A
B
C
D
WT
F
G
H
I
J
K
L
M
N
O
P

POWER SUPPLY AND GROUND CIRCUIT

< DTC/CIRCUIT DIAGNOSIS >

[REGULAR GRADE]

POWER SUPPLY AND GROUND CIRCUIT

Diagnosis Procedure

INFOID:000000006504238

1. POWER SUPPLY SYSTEM CHECK

1. Turn the ignition switch OFF.
2. Disconnect the BCM harness connector.
3. Turn the ignition switch ON.
CAUTION:
Never start the engine.
4. Check the voltage between the BCM harness connector and the ground.

BCM		—	Voltage
Connector	Terminal		
M70*1	57	Ground	Battery voltage
M67*2	70		

*1: With intelligent key system

*2: Without intelligent key system

Is the inspection result normal?

YES >> GO TO 2.

NO >> Repair or replace damaged parts.

2. GROUND SYSTEM INSPECTION

1. Turn the ignition switch OFF.
2. Check the continuity between the BCM harness connector and the ground.

BCM		—	Continuity
Connector	Terminal		
M70*1 M67*2	67	Ground	Existed

*1: With intelligent key system

*2: Without intelligent key system

Is the inspection result normal?

YES >> • Check the 10A fuse [No. 8 in fuse block (J/B)].
• Check the 40A fusible link [No. G in fuse block].

NO >> Repair or replace damaged parts.

SYMPTOM DIAGNOSIS

TPMS

Symptom Table

INFOID:000000006504239

LOW TIRE PRESSURE WARNING LAMP SYMPTOM CHART

A

B

C

D

WT

F

G

H

I

J

K

L

M

N















O

P

TPMS

< SYMPTOM DIAGNOSIS >

[REGULAR GRADE]

Diagnosis items	Symptom (Ignition switch ON)	Low tire pressure warning lamp	Cause	Action
Low tire pressure warning lamp	The low tire pressure warning lamp illuminates for 1 second, then turns OFF.	  ON 1 sec > stays OFF <small>SEIA0592E</small>	Wake-up operation for all transmitters at wheels is completed.	No system malfunctions
	The low tire pressure warning lamp repeats blinking ON for 2 seconds and OFF for 0.2 seconds.	 Blinks:  ON 2 sec > OFF 0.2 sec <small>SEIA0593E</small>	Wake-up operation for all transmitters at wheels is not completed.	Perform the wake-up operation for all transmitters at wheels. Refer to WT-22, "Work Procedure" .
	The low tire pressure warning lamp blinks once.	 Blinks 1 time ON 0.3 sec > OFF 1.0 sec <small>JPEIC0090GB</small>	The front left transmitter is not activated.	Perform the wake-up operation for the transmitter at front left wheel. Refer to WT-22, "Work Procedure" .
	The low tire pressure warning lamp repeats blinking twice.	  Blinks 2 times ON 0.3 sec > OFF 0.3 sec <small>SEIA0595E</small>	The front right transmitter is not activated.	Perform the wake-up operation for the transmitter at front right wheel. Refer to WT-22, "Work Procedure" .
	The low tire pressure warning lamp repeats blinking for 3 times.	   Blinks 3 times ON 0.3 sec > OFF 0.3 sec <small>SEIA0596E</small>	The rear right transmitter is not activated.	Perform the wake-up operation for the transmitter at rear right wheel. Refer to WT-22, "Work Procedure" .
	The low tire pressure warning lamp repeats blinking for 4 times.	    Blinks 4 times ON 0.3 sec > OFF 0.3 sec <small>SEIA0597E</small>	The rear left transmitter is not activated.	Perform the wake-up operation for the transmitter at rear left wheel. Refer to WT-22, "Work Procedure" .
	The low tire pressure warning lamp turns ON and stays illuminated.	 Comes ON and stays ON <small>SEIA0598E</small>	Low tire pressure	Check the tire pressure for all wheels and adjust to the specified value. Refer to WT-53, "Tire Air Pressure" .

TPMS

< SYMPTOM DIAGNOSIS >

[REGULAR GRADE]

Diagnosis items	Symptom (Ignition switch ON)	Low tire pressure warning lamp	Cause	Action
Low tire pressure warning lamp	The low tire pressure warning lamp repeats blinking at 0.5-second intervals for 1 minute, and then stays illuminated.	 <p style="text-align: center;">Blinks 1 min</p> <p style="text-align: center;">ON 0.5 sec > OFF 0.5 sec and stays ON</p> <p style="text-align: center;"><small>SEIA0788E</small></p>	The combination meter fuse is open or removed (or pulled out).	Check and install the combination meter fuse. If necessary, replace the fuse.
			The BCM harness connector is removed.	Check the connection conditions of the BCM harness connector, and repair if necessary.
			Tire Pressure Monitoring System (TPMS) malfunction.	<ul style="list-style-type: none"> • Perform CONSULT-III self-diagnosis. Refer to WT-12, "COMMON ITEM : CONSULT-III Function (BCM - COMMON ITEM)". • If necessary, perform transmitter ID registration. Refer to WT-23, "Work Procedure".
Turn signal lamp	The turn signal lamps do not blink twice when the transmitter is activated. Or the buzzer does not sound.	—	<ol style="list-style-type: none"> 1. The activation tool (J-45295) does not activate. 2. The ignition switch is OFF when the transmitter wake-up operation is performed. 3. The activation tool (J-45295) is not used in the correct position. 4. The transmitter is already waked up. 	<ol style="list-style-type: none"> 1. Replace the battery in the activation tool (J-45295). 2. Turn the ignition switch ON when performing the transmitter wake-up operation. 3. Operate the activation tool (J-45295) in the correct position when performing the wake-up operation. 4. No procedure.

NOTE:

If transmitter wake-up operation is not completed for two or more transmitters, the applicable low tire pressure warning lamp blinking patterns are displayed continuously.
 (Example: Blinks once/OFF/blinks 3 times = Wake-up operation is not completed at the front left wheel and rear right wheel transmitters.)

A
B
C
D
WT
F
G
H
I
J
K
L
M
N
O
P

LOW TIRE PRESSURE WARNING LAMP DOES NOT BLINKS

< SYMPTOM DIAGNOSIS >

[REGULAR GRADE]

LOW TIRE PRESSURE WARNING LAMP DOES NOT BLINKS

Description

INFOID:000000006504240

DESCRIPTION

The low tire pressure warning lamp illuminates for approximately 1 second and then turns OFF when the ignition switch is turned ON. This is to check that no abnormal condition is present in the tire pressure monitoring system.

The lamp bulb may be burnt out or the tire pressure monitoring system may be malfunctioning if the low tire pressure warning lamp does not illuminate when the ignition switch is turned ON.

Diagnosis Procedure

INFOID:000000006504241

1. CHECK LOW TIRE PRESSURE WARNING LAMP

Perform trouble diagnosis of the low tire pressure warning lamp. Refer to [WT-33, "Diagnosis Procedure"](#).

Is the inspection result normal?

- YES >> Check pin terminal and connection of each connector for damage and loose connection.
- NO >> Repair or replace damaged parts.

LOW TIRE PRESSURE WARNING LAMP DOES NOT TURN OFF

< SYMPTOM DIAGNOSIS >

[REGULAR GRADE]

LOW TIRE PRESSURE WARNING LAMP DOES NOT TURN OFF

Description

INFOID:000000006504242

The low tire pressure warning lamp does not turn OFF after several seconds is passed after engine starts.

Diagnosis Procedure

INFOID:000000006504243

1. CHECK TIRE PRESSURE

1. Turn the ignition switch ON.

CAUTION:

Never start the engine.

2. Check the tire pressure for all wheels and adjust to the specified value. Refer to [WT-53, "Tire Air Pressure"](#).

Is the inspection result normal?

YES >> GO TO 2.

NO >> Inspect or repair the tires or wheels.

2. CHECK LOW TIRE PRESSURE WARNING LAMP

Check low tire pressure warning lamp display.

Does not low tire pressure warning lamp turn OFF?

YES >> GO TO 3.

NO >> INSPECTION END

3. CHECK BCM

 With CONSULT-III

Perform "SELF-DIAG RESULTS" in "AIR PRESSURE MONITOR" of "BCM".

Is any DTC detected?

YES >> Check the DTC. Refer to [BCS-73, "DTC Index"](#) (With intelligent key system), [BCS-137, "DTC Index"](#) (Without intelligent key system).

NO >> GO TO 4.

4. CHECK BCM POWER SUPPLY AND GROUND

1. Turn the ignition switch OFF.
2. Disconnect the BCM harness connector.
3. Turn the ignition switch ON.

CAUTION:

Never start the engine.

4. Check the voltage between the BCM harness connector and the ground.

BCM		—	Voltage
Connector	Terminal		
M70 ^{*1}	57	Ground	Battery voltage
M67 ^{*2}	70		

*1: With intelligent key system

*2: Without intelligent key system

Is the inspection result normal?

YES >> Replace BCM. Refer to [BCS-78, "Exploded View"](#) (With intelligent key system), [BCS-141, "Exploded View"](#) (Without intelligent key system).

NO >> Repair or replace damaged parts.

LOW TIRE PRESSURE WARNING LAMP BLINKS

< SYMPTOM DIAGNOSIS >

[REGULAR GRADE]

LOW TIRE PRESSURE WARNING LAMP BLINKS

Description

INFOID:000000006935198

The low tire pressure warning lamp blinks when the ignition switch is turned ON.

NOTE:

The position of an inactive transmitter can be identified by checking the blinking timing of the low tire pressure warning lamp.

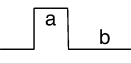
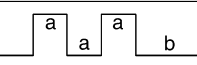
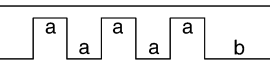
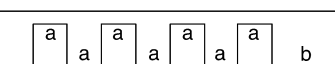
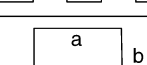
Low tire pressure warning lamp blinking timing		Activation tire position
ON OFF	 a : 0.3 sec. b : 1.0 sec.	Front LH
ON OFF	 a : 0.3 sec. b : 1.0 sec.	Front RH
ON OFF	 a : 0.3 sec. b : 1.0 sec.	Rear RH
ON OFF	 a : 0.3 sec. b : 1.0 sec.	Rear LH
ON OFF	 a : 2 sec. b : 0.2 sec.	All tires

JPEIC0089GB

Diagnosis Procedure

INFOID:000000006935199

1. TRANSMITTER WAKE-UP OPERATION

Perform the transmitter wake-up. Refer to [WT-22, "Work Procedure"](#).

Is the transmitter wake-up completed?

YES >> GO TO 2.

NO >> Perform trouble diagnosis for the transmitter. Refer to [WT-27, "Diagnosis Procedure"](#).

2. TRANSMITTER ID REGISTRATION

Perform transmitter ID registration. Refer to [WT-23, "Work Procedure"](#).

Is transmitter ID registration completed?

YES >> INSPECTION END

NO >> Perform the self-diagnosis for "AIR PRESSURE MONITOR". Refer to [BCS-73, "DTC Index"](#) (With intelligent key system), [BCS-137, "DTC Index"](#) (Without intelligent key system).

ID REGISTRATION CANNOT BE COMPLETED

< SYMPTOM DIAGNOSIS >

[REGULAR GRADE]

ID REGISTRATION CANNOT BE COMPLETED

Description

INFOID:000000006504248

DESCRIPTION

The ID of the transmitter installed in each wheel cannot be registered in the tire pressure monitoring system. Inspect the transmitter or the tire pressure monitoring system circuit.

Diagnosis Procedure

INFOID:000000006935204

1. TRANSMITTER WAKE-UP

Perform the transmitter wake-up. Refer to [WT-22. "Work Procedure"](#).

Is the transmitter wake-up completed?

YES >> GO TO 3.

NO >> GO TO 2.

2. CHECK ACTIVATION TOOL

Check activation tool.

Is the inspection result normal?

YES >> GO TO 3.

NO >> Replace battery for activation tool, or repair or replace activation tool.

3. TRANSMITTER ID REGISTRATION

Perform transmitter ID registration. Refer to [WT-23. "Work Procedure"](#).

Is transmitter ID registration completed?

YES >> INSPECTION END

NO >> GO TO 4.

4. CHECK TIRE PRESSURE SIGNAL

Change the work location and perform ID registration again.

When ID registration is performed, which wheels do not react?

All wheels react and ID registration is possible.>>INSPECTION END

Only certain wheel(s) do not react.>>Replace applicable transmitter. Refer to [WT-47. "WITH INTELLIGENT KEY : Removal and Installation"](#) (With intelligent key system), [WT-50. "WITHOUT INTELLIGENT KEY : Removal and Installation"](#) (Without intelligent key system).

All wheels do not react.>>Check the tire pressure receiver. Refer to [DLK-75. "Component Function Check"](#) (With intelligent key system), [DLK-254. "Component Function Check"](#) (Without intelligent key system).

A
B
C
D
E
F
G
H
I
J
K
L
M
N
O
P

WT

NOISE, VIBRATION AND HARSHNESS (NVH) TROUBLESHOOTING

< SYMPTOM DIAGNOSIS >

[REGULAR GRADE]

NOISE, VIBRATION AND HARSHNESS (NVH) TROUBLESHOOTING

NVH Troubleshooting Chart

INFOID:000000006504251

Use chart below to find the cause of the symptom. If necessary, repair or replace these parts.

Symptom		Possible cause and SUSPECTED PARTS										Reference						
		Improper installation, looseness	Out-of-round	unbalance	Incorrect tire pressure	Uneven tire wear	Deformation or damage	Non-uniformity	Incorrect tire size	FRONT AXLE AND FRONT SUSPENSION	REAR AXLE AND REAR SUSPENSION	TIRES	ROAD WHEELS	DRIVE SHAFT	BRAKE	STEERING		
Symptom	TIRES	Noise	x	x	x	x	x	x	x		x	x		x	x	x	x	
		Shake	x	x	x	x	x	x		x	x	x		x	x	x	x	
		Vibration				x				x	x	x			x			x
		Shimmy	x	x	x	x	x	x	x	x	x	x		x		x	x	x
		Judder	x	x	x	x	x	x		x	x	x		x		x	x	x
		Poor quality ride or handling	x	x	x	x	x	x		x	x		x	x				
	ROAD WHEEL	Noise	x	x	x				x			x	x	x		x	x	x
		Shake	x	x	x				x			x	x	x		x	x	x
		Shimmy, Judder	x	x	x				x			x	x	x			x	x
		Poor quality ride or handling	x	x	x				x			x	x	x				

x: Applicable

PERIODIC MAINTENANCE

ROAD WHEEL

Adjustment

INFOID:000000006504252

BALANCING WHEELS (BONDING WEIGHT TYPE)

Preparation Before Adjustment

Using releasing agent, remove double-faced adhesive tape from the road wheel.

CAUTION:

- **Be careful not to scratch the road wheel during removal.**
- **After removing double-faced adhesive tape, wipe clean traces of releasing agent from the road wheel.**

Wheel Balance Adjustment

If a tire balance machine has adhesion balance weight mode settings and drive-in weight mode setting, select and adjust a drive-in weight mode suitable for road wheels.

1. Set road wheel on tire balance machine using the center hole as a guide. Start the tire balance machine.
2. When inner and outer unbalance values are shown on the tire balance machine indicator, multiply outer unbalance value by $5/3$ to determine balance weight that should be used. Select the outer balance weight with a value closest to the calculated value above and install to the designated outer position of, or at the designated angle in relation to the road wheel.

CAUTION:

- **Do not install the inner balance weight before installing the outer balance weight.**
- **Before installing the balance weight, be sure to clean the mating surface of the road wheel.**

- a. Indicated unbalance value $\times 5/3 =$ balance weight to be installed

Calculation example:

$23 \text{ g (0.81 oz)} \times 5/3 = 38.33 \text{ g (1.35 oz)} \Rightarrow 40 \text{ g (1.41 oz)}$ balance weight (closer to calculated balance weight value)

NOTE:

Note that balance weight value must be closer to the calculated balance weight value.

Example:

$37.4 \Rightarrow 35 \text{ g (1.23 oz)}$

$37.5 \Rightarrow 40 \text{ g (1.41 oz)}$

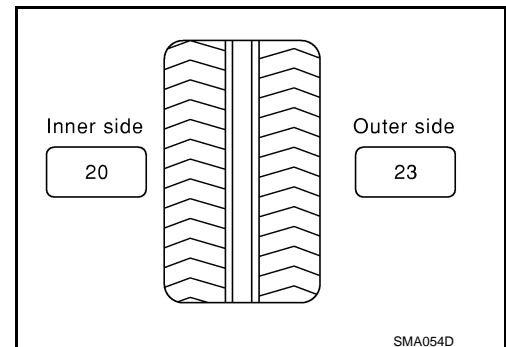

- b. Installed balance weight in the position.

ROAD WHEEL

< PERIODIC MAINTENANCE >

[REGULAR GRADE]

- When installing balance weight (1) to road wheels, set it into the grooved area (A) on the inner wall of the road wheel as shown in the figure so that the balance weight center (B) is aligned with the tire balance machine indication position (angle) (C).

CAUTION:

- Always use genuine NISSAN adhesion balance weights.
- Balance weights are non-reusable; always replace with new ones.
- Do not install more than three sheets of balance weight.

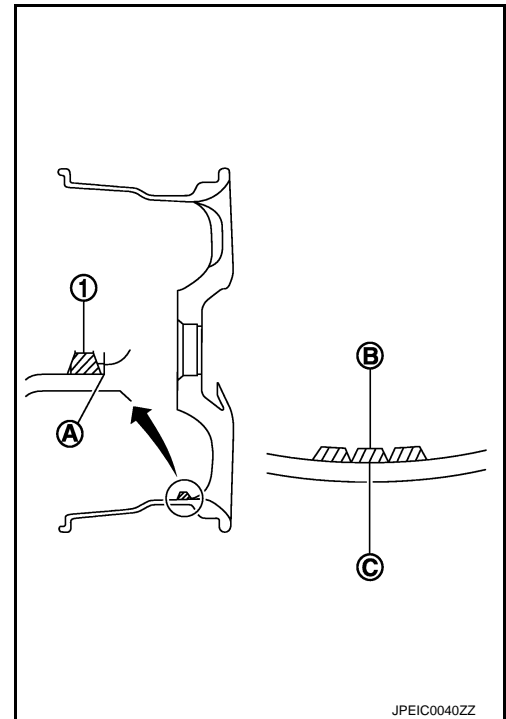

- c. If calculated balance weight value exceeds 50 g (1.76 oz), install two balance weight sheets in line with each other as shown in the figure.

CAUTION:

Do not install one balance weight sheet on top of another.

3. Start the tire balance machine again.
4. Install drive-in balance weight on inner side of road wheel in the tire balance machine indication position (angle).

CAUTION:

Do not install more than two balance weight.

5. Start the tire balance machine. Make sure that inner and outer residual unbalance values are 10 g (0.35 oz) each or below.
6. If either residual unbalance value exceeds 10 g (0.35 oz), repeat installation procedures.

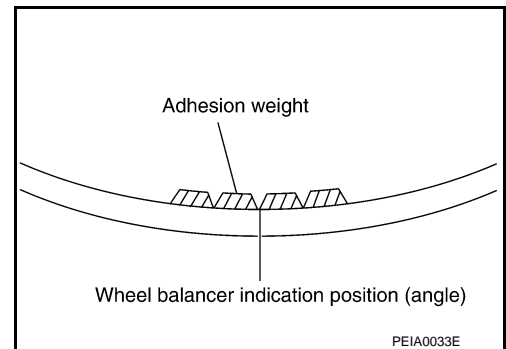

Limit

Dynamic (At flange) : Refer to [WT-53, "Road Wheel"](#).

Static (At flange) : Refer to [WT-53, "Road Wheel"](#).

TIRE ROTATION

- Follow the maintenance schedule for tire rotation service intervals. Refer to [MA-4, "Explanation of General Maintenance"](#).
- When installing the wheel, tighten wheel nuts to the specified torque.

CAUTION:

- Never include the T-type spare tire when rotating the tires.
- When installing wheels, tighten them diagonally by dividing the work two to three times in order to prevent the wheels from developing any distortion.
- Be careful not to tighten wheel nut at torque exceeding the criteria for preventing strain of disc rotor.
- Use NISSAN genuine wheel nuts for aluminum wheels.

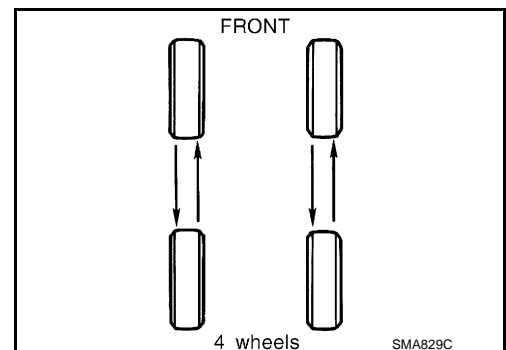

Wheel nuts tightening torque : Refer to [WT-45, "Exploded View"](#).

- Perform the ID registration, after tire rotation. Refer to [WT-23, "Work Procedure"](#).

REMOVAL AND INSTALLATION

ROAD WHEEL TIRE ASSEMBLY

Exploded View

INFOID:000000006504253

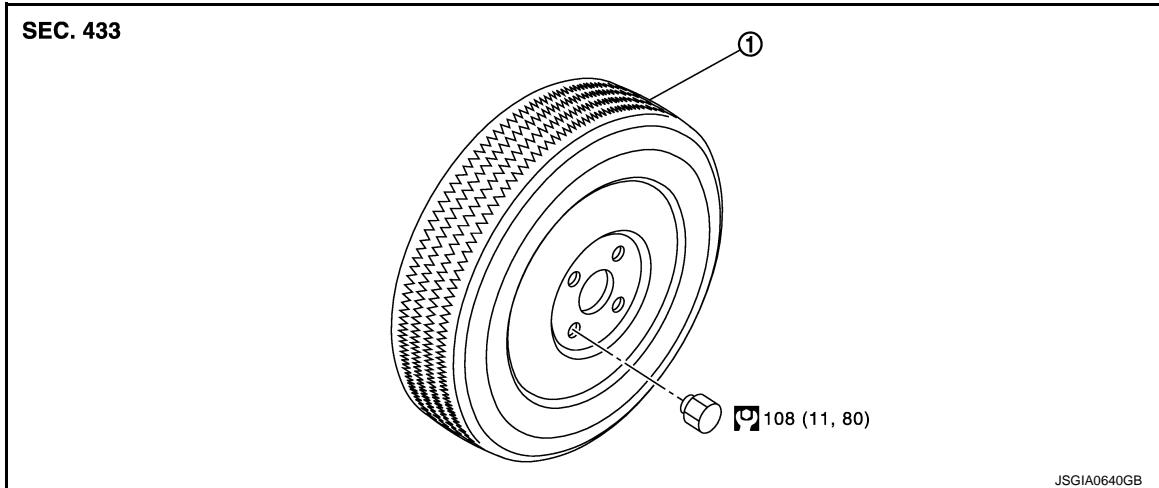

1. Tire assembly

Refer to [GI-4, "Components"](#) for symbols in the figure.

Removal and Installation

INFOID:000000006504254

REMOVAL

1. Remove wheel nuts.
2. Remove tire assembly.

INSTALLATION

Note the following, install in the reverse order of removal.

- When replacing or rotating wheels, perform the ID registration. Refer to [WT-23, "Work Procedure"](#).

Inspection

INFOID:000000006504255

ALUMINUM WHEEL

1. Check tires for wear and improper inflation.
2. Check wheels for deformation, cracks and other damage. If deformed, remove wheel and check wheel runout.
 - a. Remove tire from aluminum wheel and mount on a tire balance machine.
 - b. Set dial indicator as shown in the figure.
 - c. Check runout, If the axial runout (A) or radial runout (B) exceeds the limit, replace aluminum wheel.

Limit

Axial runout (A) : Refer to [WT-53, "Road Wheel"](#).

Radial runout (B) : Refer to [WT-53, "Road Wheel"](#).

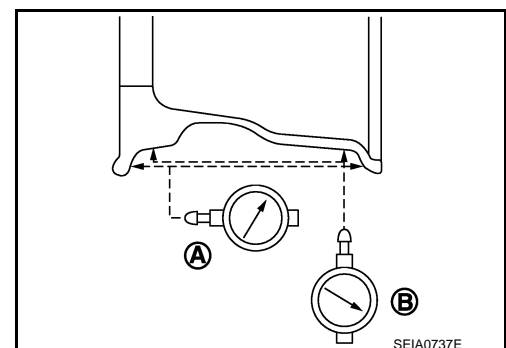

STEEL WHEEL

1. Check tires for wear and improper inflation.

ROAD WHEEL TIRE ASSEMBLY

[REGULAR GRADE]

< REMOVAL AND INSTALLATION >

2. Check wheels for deformation, clacks and other damage. If deformed, remove wheel and check wheel runout.
 - a. Remove tire from steel wheel and mount wheel on a tire balance machine.
 - b. Set two dial indicators as shown in the illustration.
 - c. Set each dial indicator to "0".
 - d. Rotate wheel and check dial indicators at several points around the circumference of the wheel.
 - e. Calculate runout at each point as shown below.

Axial runout (A) : $(1+2)/2$

Radial runout (B) : $(3+4)/2$

- f. Select maximum positive runout value and the maximum negative value. Add the two values to determine total runout.

CAUTION:

In case a positive or negative value is not available, use the maximum value (negative or positive) for total runout.

Limit

(A) : Refer to [WT-53, "Road Wheel"](#).

(B) : Refer to [WT-53, "Road Wheel"](#).

- g. If the total runout value exceeds limit, replace steel wheel.

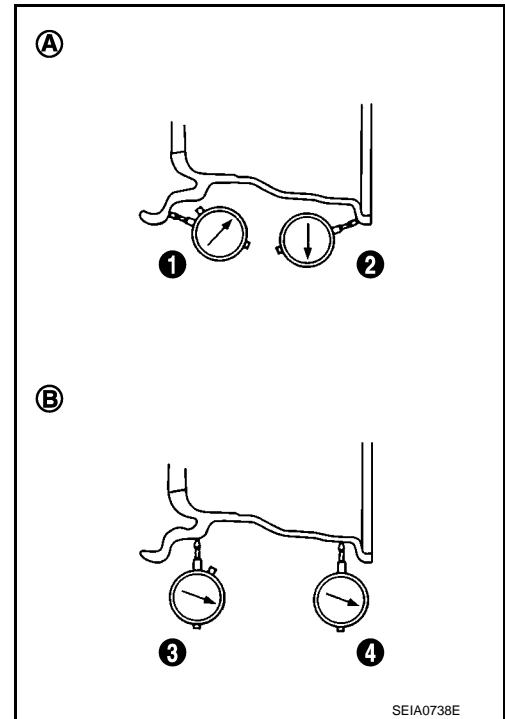

TRANSMITTER

< REMOVAL AND INSTALLATION >

[REGULAR GRADE]

TRANSMITTER WITH INTELLIGENT KEY

WITH INTELLIGENT KEY : Exploded View

INFOID:000000006934490

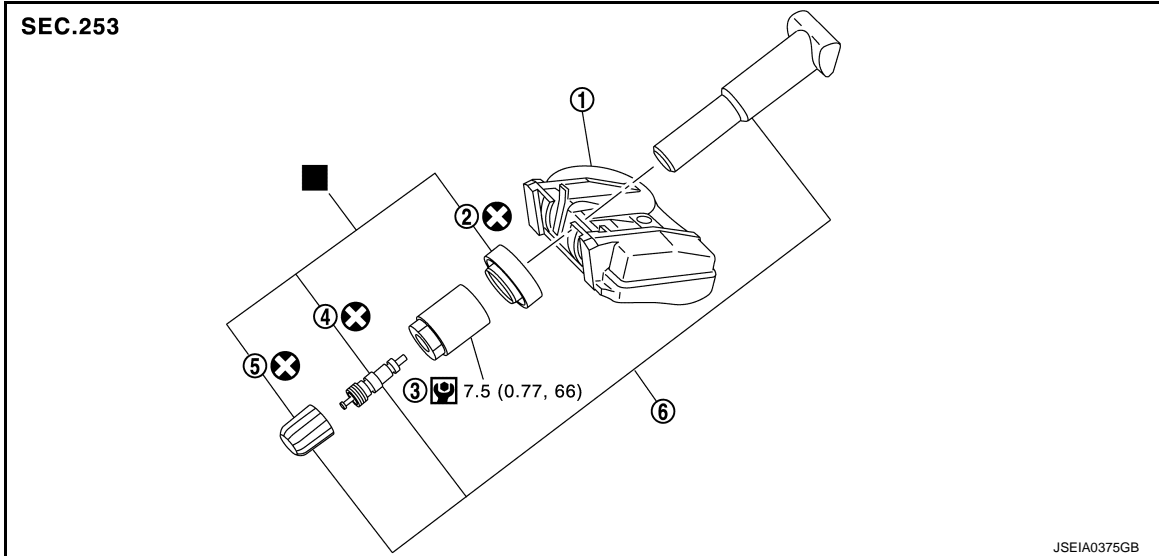

1. Tire pressure sensor

2. Grommet seal

3. Valve nut

4. Valve core

5. Valve cap

6. Valve stem assembly

■: Parts that are replaced as a set when the tire is replaced.

Refer to [GI-4, "Components"](#) for symbols not described above.

WITH INTELLIGENT KEY : Removal and Installation

INFOID:000000006934491

REMOVAL

1. Remove tire assembly. Refer to [WT-45, "Removal and Installation"](#).

2. Remove valve cap, valve core and then deflate tire.

NOTE:

If the tire is reused, apply a matching mark to the position of the tire road wheel valve hole for the purpose of wheel balance adjustment after installation.

3. Remove valve nut retaining tire pressure sensor and allow tire pressure sensor to fall into tire.

4. Use the tire changer and disengage the tire beads.

CAUTION:

- Verify that the tire pressure sensor (1) is at the bottom of the tire while performing the above.
- Be sure not to damage the road wheel or tire pressure sensor.

5. Apply bead cream or an equivalent to the tire beads.

6. Set tire onto the tire changer turntable so that the tire pressure sensor inside the tire is located close to the road wheel valve hole.

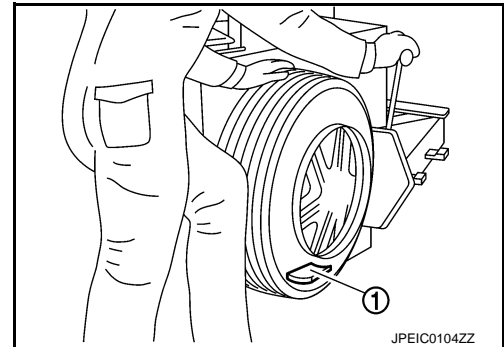

TRANSMITTER

< REMOVAL AND INSTALLATION >

[REGULAR GRADE]

- Turn tire so that valve hole is at bottom and bounce so that tire pressure sensor (1) is near valve hole. Carefully lift tire onto turntable and position valve hole (and tire pressure sensor) 270 degree from mounting/dismounting head (2).

CAUTION:

Be sure not to damage the road wheel and tire pressure sensor.

- Remove tire pressure sensor from tire.
- Remove the grommet seal.

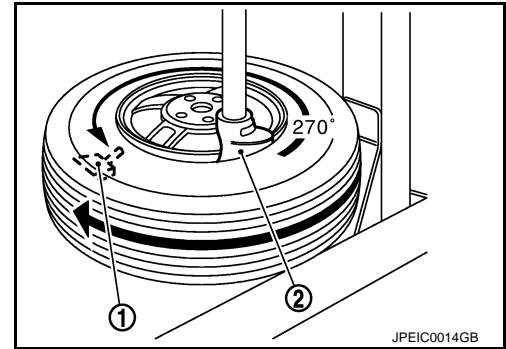

- Remove valve stem in the direction (←).

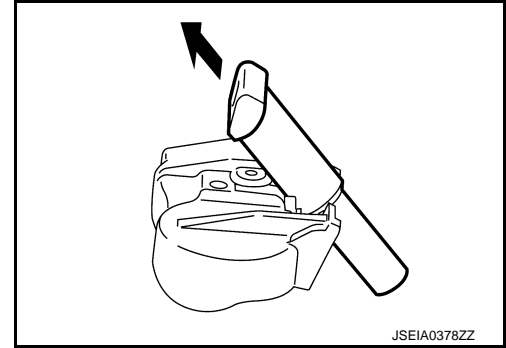

INSTALLATION

CAUTION:

Replace valve stem assembly if the valve stem has deformations, cracks, damage or corrosion.

- Apply bead cream or an equivalent to the tire beads.
- Install the tire inside beads (1) onto the road wheel (2) in the position shown in the figure.
- Install grommet seal to the tire pressure sensor assembly.

CAUTION:

- **Never reuse grommet seal.**
- **Insert grommet seal all the way to the base.**

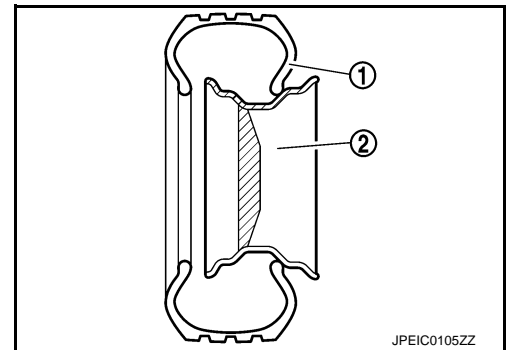

- Follow the procedure below and install the tire pressure sensor to the road wheel.

TRANSMITTER

< REMOVAL AND INSTALLATION >

[REGULAR GRADE]

- a. Check the condition of valve stem before installing tire pressure sensor to road wheel.

CAUTION:

The base of valve stem (A) must be positioned in the groove of the metal plate as shown in the figure.

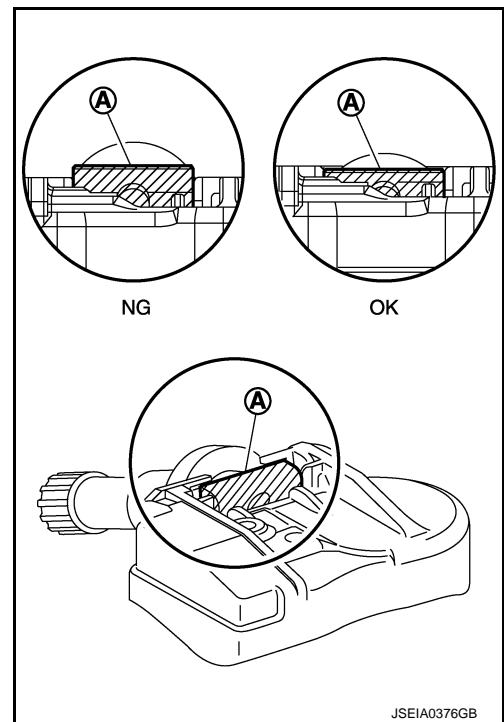

- b. Hold tire pressure sensor as shown in the figure, and press the sensor in the direction shown by arrow (←) to bring it into absolute contact with road wheel. After this, tighten valve nut to the specified torque.

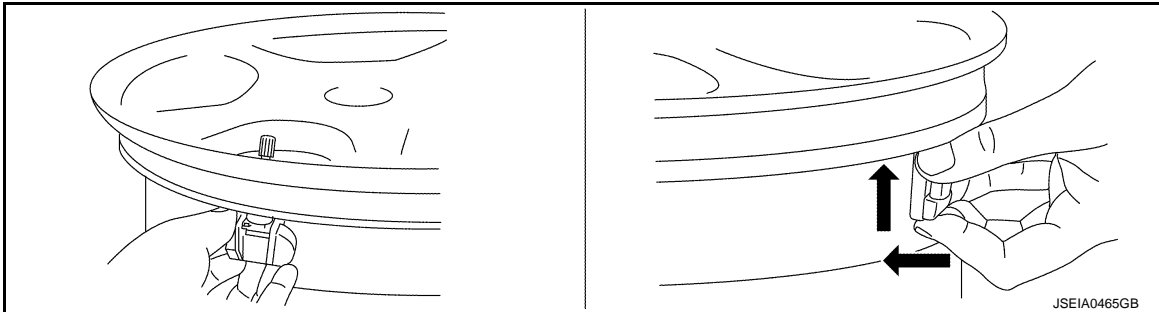

CAUTION:

- Never reuse valve core and valve cap.
- Check that grommet seal is free of foreign matter.
- Check that grommet seal contacts horizontally with road wheel.
- Check again that the base of valve stem is positioned in the groove of the metal plate.
- Manually tighten valve nut all the way to the wheel. (Never use a power tool to avoid impact.)

5. Set the tire onto the turntable so that the tire changer arm (2) is at a position approximately 270° from the tire pressure sensor (1).

CAUTION:

Be sure that the arm does not contact the tire pressure sensor.

6. Install the tire outer side beads onto the road wheel.

CAUTION:

When installing, check that the tire does not turn together with the road wheel.

7. Check the tire pressure for all wheels and adjust to the specified value. Refer to [WT-53. "Tire Air Pressure"](#).

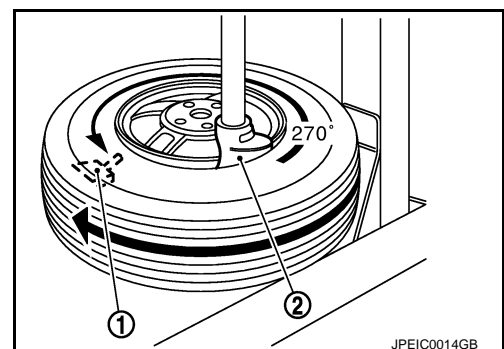

NOTE:

Before adding air, align the tire with the position of the matching mark applied at the time of removal.

8. Install tire to the vehicle. Refer to [WT-45. "Removal and Installation"](#).

9. Perform tire pressure sensor ID registration. Refer to [WT-23. "Work Procedure"](#).

WITHOUT INTELLIGENT KEY

A
B
C
D
WT
F
G
H
I
J
K
L
M
N
O
P

TRANSMITTER

< REMOVAL AND INSTALLATION >

[REGULAR GRADE]

WITHOUT INTELLIGENT KEY : Exploded View

INFOID:000000006504256

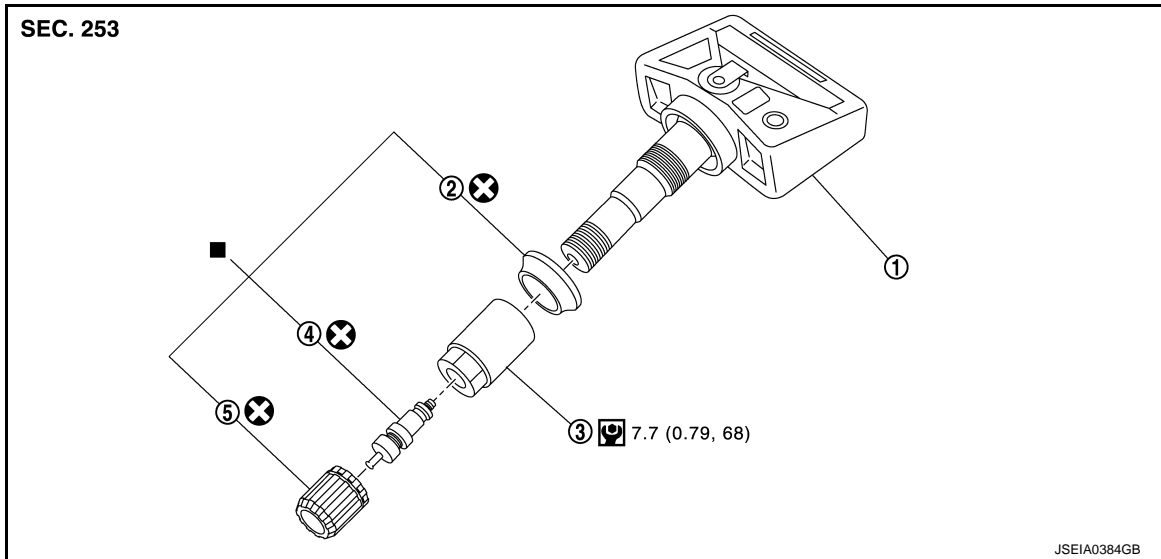

- | | | |
|----------------|-----------------|--------------|
| 1. Transmitter | 2. Grommet seal | 3. Valve nut |
| 4. Valve core | 5. Cap | |

■ : Parts that are replaced as a set when the tire is replaced.

Refer to [GI-4, "Components"](#) for symbols not described above.

WITHOUT INTELLIGENT KEY : Removal and Installation

INFOID:000000006504257

REMOVAL

1. Remove tire assembly. Refer to [WT-45, "Removal and Installation"](#).
2. Remove valve cap, valve core and then deflate tire.

NOTE:

If the tire is reused, apply a matching mark to the position of the tire road wheel valve hole for the purpose of wheel balance adjustment after installation.

3. Remove valve nut retaining tire pressure sensor and allow tire pressure sensor to fall into tire.
4. Use the tire changer and disengage the tire beads.

CAUTION:

- Verify that the tire pressure sensor (1) is at the bottom of the tire while performing the above.
- Be sure not to damage the road wheel or tire pressure sensor.

5. Apply bead cream or an equivalent to the tire beads.
6. Set tire onto the tire changer turntable so that the tire pressure sensor inside the tire is located close to the road wheel valve hole.

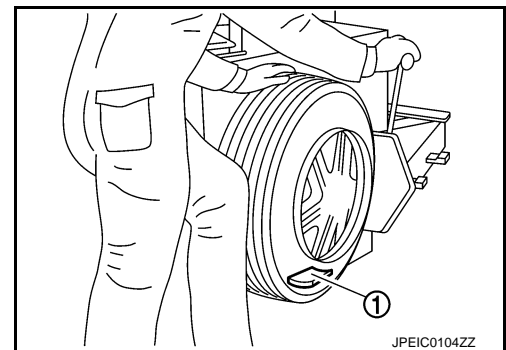

TRANSMITTER

< REMOVAL AND INSTALLATION >

[REGULAR GRADE]

- Turn tire so that valve hole is at bottom and bounce so that tire pressure sensor (1) is near valve hole. Carefully lift tire onto turntable and position valve hole (and tire pressure sensor) 270 degree from mounting/dismounting head (2).

CAUTION:

Be sure not to damage the road wheel and tire pressure sensor.

- Remove tire pressure sensor from tire.
- Remove the grommet seal.

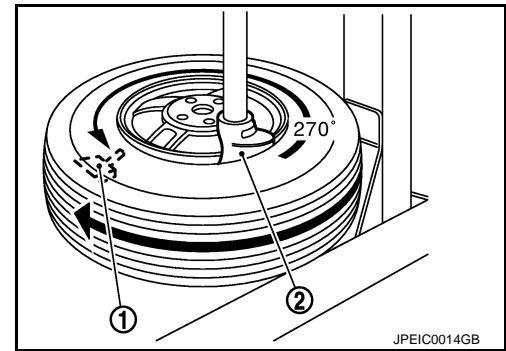

INSTALLATION

- Apply bead cream or an equivalent to the tire beads.
- Install the tire inside beads (1) onto the road wheel (2) in the position shown in the figure.
- Install grommet seal to the tire pressure sensor.

CAUTION:

- Never reuse grommet seal.
- Insert grommet seal all the way to the base.

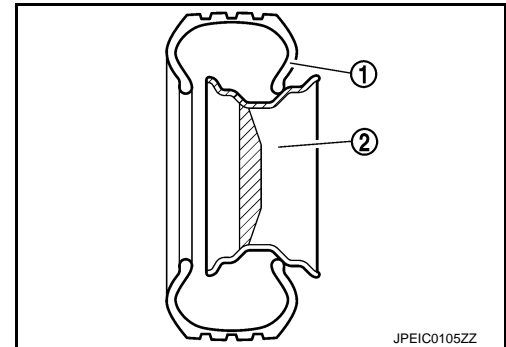

- Hold tire pressure sensor as shown in the figure, and press the sensor in the direction shown by arrow (←) to bring it into absolute contact with valve hole. After this, tighten valve nut to the specified torque.

CAUTION:

- Never reuse valve core and valve cap.
- Check that grommet seal is free of foreign matter.
- Check that grommet seal contacts horizontally with road wheel.
- Manually tighten valve nut all the way to the wheel. (Never use a power tool to avoid impact.)

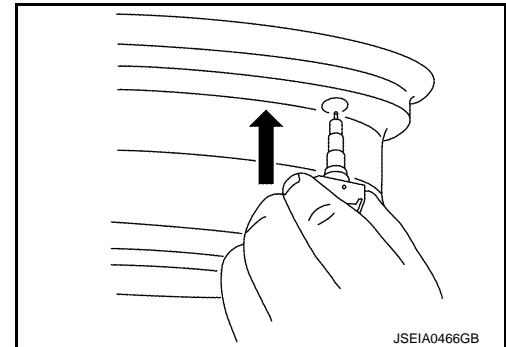

- Set the tire onto the turntable so that the tire changer arm (2) is at a position approximately 270° from the tire pressure sensor (1).

CAUTION:

Be sure that the arm does not contact the tire pressure sensor.

- Install the tire outer side beads onto the road wheel.

CAUTION:

When installing, check that the tire does not turn together with the road wheel.

- Check the tire pressure for all wheels and adjust to the specified value. Refer to [WT-53, "Tire Air Pressure"](#).

NOTE:

Before adding air, align the tire with the position of the matching mark applied at the time of removal.

- Install tire to the vehicle. Refer to [WT-45, "Removal and Installation"](#).
- Perform tire pressure sensor ID registration. Refer to [WT-23, "Work Procedure"](#).

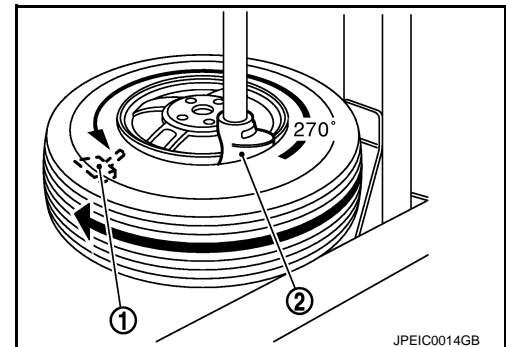

A
B
C
D
WT
F
G
H
I
J
K
L
M
N
O
P

TIRE PRESSURE RECEIVER

< REMOVAL AND INSTALLATION >

[REGULAR GRADE]

TIRE PRESSURE RECEIVER

Removal and Installation

INFOID:000000006504258

REMOVAL

1. Remove the glove box assembly. Refer to [IP-12, "Exploded View"](#).
2. Remove the glove box cover. Refer to [IP-12, "Exploded View"](#).
3. Disconnect tire pressure receiver harness connector.
4. Remove tire pressure receiver mounting screw.
5. Remove tire pressure receiver.

INSTALLATION

Install is the reverse order of removal.

SERVICE DATA AND SPECIFICATIONS (SDS)

< SERVICE DATA AND SPECIFICATIONS (SDS)

[REGULAR GRADE]

SERVICE DATA AND SPECIFICATIONS (SDS)

SERVICE DATA AND SPECIFICATIONS (SDS)

Road Wheel

INFOID:0000000006504259

ALUMINUM WHEEL

Item		Limit
Radial runout	Axial runout	Less than 0.3 mm (0.012 in)
	Radial runout	
Allowable unbalance	Dynamic (At flange)	Less than 10 g (0.35 oz) (one side)
	Static (At flange)	Less than 20 g (0.70 oz)

STEEL WHEEL

Item		Limit	
Radial runout	Conventional	Axial runout (Average)	Less than 0.8 mm (0.031 in)
		Radial runout (Average)	Less than 0.5 mm (0.020 in)
	Emergency	Axial runout (Average)	Less than 1.2 mm (0.031 in)
		Radial runout (Average)	Less than 1.0 mm (0.020 in)
Allowable unbalance	Dynamic (At flange)	Less than 10 g (0.35 oz) (one side)	
	Static (At flange)	Less than 20 g (0.70 oz)	

Tire Air Pressure

INFOID:0000000006504260

Unit: kPa (kg/cm², psi)

Tire size	Air pressure	
	Front	Rear
P195/60R15 87H	230 (2.3, 33)	230 (2.3, 33)
P195/55R16 86V	230 (2.3, 33)	230 (2.3, 33)
T125/70D15 95M	420 (4.2, 60)	420 (4.2, 60)

ROAD WHEEL TIRE ASSEMBLY

< SPEC CHANGE INFORMATION >

[Krom]

SPEC CHANGE INFORMATION

ROAD WHEEL TIRE ASSEMBLY

Road Wheel Tire Assembly

INFOID:000000006504261

The wheels are made of specifically-designed bright aluminum with their surface treated with sputtering coating.

Z12 Krom	Item	Data
Aluminum road wheels	Size	16 × 6J
	Offset	+ 1.65 in (+42 mm)
	P. C. D.	4.5 in (114.3 mm)
Tires	Tire size	195/ 55R16 86V

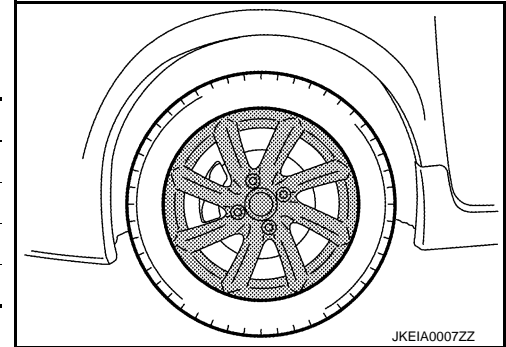

CAUTION:

- Wheels with sputtering coating are not plated wheels. Never use a cleaner for plating, abrasive cleanser, and brush. (Since sputtering is one of the methods of metallic coating, the surface treatment may be subject to damage, peel, or corrosion.)
- Wash regularly with a sponge dampened in a mild soap solution, especially during winter months in areas where road salt is used. Salt could discolor the wheels if not removed.