

A
B
C
D
E
F
G
H
I
J
K
L
M
N
O
P

SECTION **EXT** EXTERIOR

CONTENTS

SYMPTOM DIAGNOSIS	2	Removal and Installation	15
SQUEAK AND RATTLE TROUBLE DIAG- NOSES	2	FRONT GRILLE	17
Work Flow	2	Exploded View	17
Inspection Procedure	4	Removal and Installation	17
Diagnostic Worksheet	6	COWL TOP	19
PRECAUTION	8	Exploded View	19
PRECAUTIONS	8	Removal and Installation	19
Precaution for Supplemental Restraint System (SRS) "AIR BAG" and "SEAT BELT PRE-TEN- SIONER"	8	FENDER PROTECTOR	21
Precautions Necessary for Steering Wheel Rota- tion After Battery Disconnection	8	FENDER PROTECTOR	21
Precaution for Procedure without Cowl Top Cover.....	9	FENDER PROTECTOR : Exploded View	21
Precaution for Work	9	FENDER PROTECTOR : Removal and Installa- tion	21
PREPARATION	10	FLOOR SIDE FAIRING	22
PREPARATION	10	Exploded View	22
Special Service Tools	10	Removal and Installation	22
Commercial Service Tools	10	ROOF SIDE MOLDING	23
REMOVAL AND INSTALLATION	11	Exploded View	23
FRONT BUMPER	11	Removal and Installation	23
Exploded View	11	DOOR OUTSIDE MOLDING	26
Removal and Installation	12	Exploded View	26
REAR BUMPER	14	Removal and Installation	26
Exploded View	14	REAR PILLAR FINISHER	28
		Exploded View	28
		Removal and Installation	28

EXT

SQUEAK AND RATTLE TROUBLE DIAGNOSES

< SYMPTOM DIAGNOSIS >

SYMPTOM DIAGNOSIS

SQUEAK AND RATTLE TROUBLE DIAGNOSES

Work Flow

INFOID:000000007769485

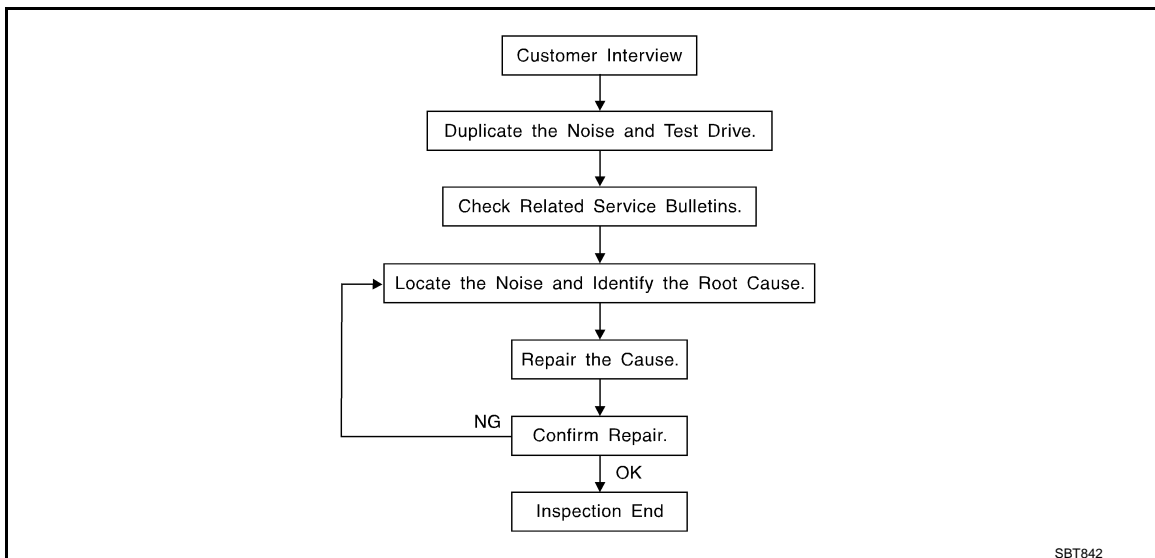

CUSTOMER INTERVIEW

Interview the customer if possible, to determine the conditions that exist when the noise occurs. Use the Diagnostic Worksheet during the interview to document the facts and conditions when the noise occurs and any of customer's comments; refer to [EXT-6, "Diagnostic Worksheet"](#). This information is necessary to duplicate the conditions that exist when the noise occurs.

- The customer may not be able to provide a detailed description or the location of the noise. Attempt to obtain all the facts and conditions that exist when the noise occurs (or does not occur).
- If there is more than one noise in the vehicle, perform a diagnosis and repair the noise that the customer is concerned about. This can be accomplished by performing a cruise test on the vehicle with the customer.
- After identifying the type of noise, isolate the noise in terms of its characteristics. The noise characteristics are provided so the customer, service adviser and technician are all speaking the same language when defining the noise.
- Squeak – (Like tennis shoes on a clean floor)
Squeak characteristics include the light contact/fast movement/brought on by road conditions/hard surfaces = higher pitch noise/softer surfaces = lower pitch noises/edge to surface = chirping
- Creak – (Like walking on an old wooden floor)
Creak characteristics include firm contact/slow movement/twisting with a rotational movement/pitch dependent on materials/often brought on by activity.
- Rattle – (Like shaking a baby rattle)
Rattle characteristics include the fast repeated contact/vibration or similar movement/loose parts/missing clip or fastener/incorrect clearance.
- Knock – (Like a knock on a door)
Knock characteristics include hollow sounding/sometimes repeating/often brought on by driver action.
- Tick – (Like a clock second hand)
Tick characteristics include gentle contacting of light materials/loose components/can be caused by driver action or road conditions.
- Thump – (Heavy, muffled knock noise)
Thump characteristics include softer knock/dead sound often brought on by activity.
- Buzz – (Like a bumblebee)
Buzz characteristics include high frequency rattle/firm contact.
- Often the degree of acceptable noise level will vary depending up on the person. A noise that a technician may judge as acceptable may be very irritating to the customer.
- Weather conditions, especially humidity and temperature, may have a great effect on noise level.

DUPLICATE THE NOISE AND TEST DRIVE

SQUEAK AND RATTLE TROUBLE DIAGNOSES

< SYMPTOM DIAGNOSIS >

If possible, drive the vehicle with the customer until the noise is duplicated. Note any additional information on the Diagnostic Worksheet regarding the conditions or location of the noise. This information can be used to duplicate the same conditions when the repair is reconfirmed.

If the noise can be duplicated easily during the test drive, to help identify the source of the noise, try to duplicate the noise with the vehicle stopped by doing one or all of the following:

- 1) Close a door.
 - 2) Tap or push/pull around the area where the noise appears to be coming from.
 - 3) Rev the engine.
 - 4) Use a floor jack to recreate vehicle "twist".
 - 5) At idle, apply engine load (electrical load, half-clutch on M/T models, drive position on A/T models).
 - 6) Raise the vehicle on a hoist and hit a tire with a rubber hammer.
- Drive the vehicle and attempt to duplicate the conditions the customer states exist when the noise occurs.
 - If it is difficult to duplicate the noise, drive the vehicle slowly on an undulating or rough road to stress the vehicle body.

CHECK RELATED SERVICE BULLETINS

After verifying the customer concern or symptom, check ASIST for Technical Service Bulletins (TSBs) related to that concern or symptom.

If a TSB relates to the symptom, follow the procedure to repair the noise.

LOCATE THE NOISE AND IDENTIFY THE ROOT CAUSE

1. Narrow down the noise to a general area. To help pinpoint the source of the noise, use a listening tool (Chassis ear: J-39570, Engine ear and mechanics stethoscope).
2. Narrow down the noise to a more specific area and identify the cause of the noise by:
 - Removing the components in the area that is are suspected to be the cause of the noise. Do not use too much force when removing clips and fasteners, otherwise clips and fastener can be broken or lost during the repair, resulting in the creation of new noise.
 - Tapping or pushing/pulling the component that is are suspected to be the cause of the noise. Do not tap or push/pull the component with excessive force, otherwise the noise will be eliminated only temporarily.
 - Feeling for a vibration by hand by touching the component(s) that is are suspected to be the cause of the noise.
 - Placing a piece of paper between components that are suspected to be the cause of the noise.
 - Looking for loose components and contact marks.
Refer to [EXT-4. "Inspection Procedure"](#).

REPAIR THE CAUSE

- If the cause is a loose component, tighten the component securely.
- If the cause is insufficient clearance between components:
 - Separate components by repositioning or loosening and retightening the component, if possible.
 - Insulate components with a suitable insulator such as urethane pads, foam blocks, felt cloth tape or urethane tape. A Nissan Squeak and Rattle Kit (J-43980) is available through the authorized Nissan Parts Department.

CAUTION:

Never use excessive force as many components are constructed of plastic and may be damaged.

NOTE:

Always check with the Parts Department for the latest parts information.

The following materials are contained in the Nissan Squeak and Rattle Kit (J-43980). Each item can be ordered separately as needed.

URETHANE PADS [1.5 mm (0.059 in) thick]

Insulates connectors, harness, etc.

76268-9E005: 100 × 135 mm (3.94 × 5.31 in)/76884-71L01: 60 × 85 mm (2.36 × 3.35 in)/76884-71L02: 15 × 25 mm (0.59 × 0.98 in)

INSULATOR (Foam blocks)

Insulates components from contact. Can be used to fill space behind a panel.

73982-9E000: 45 mm (1.77 in) thick, 50 × 50 mm (1.97 × 1.97 in)/73982-

50Y00: 10 mm (0.39 in) thick, 50 × 50 mm (1.97 × 1.97 in)

INSULATOR (Light foam block)

80845-71L00: 30 mm (1.18 in) thick, 30 × 50 mm (1.18 × 1.97in)

FELT CLOTHTAPE

Used to insulate where movement does not occur. Ideal for instrument panel applications.

SQUEAK AND RATTLE TROUBLE DIAGNOSES

< SYMPTOM DIAGNOSIS >

68370-4B000: 15 × 25 mm (0.59 × 0.98 in) pad/68239-13E00: 5 mm (0.20 in) wide tape roll

The following materials, not found in the kit, can also be used to repair squeaks and rattles.

UHMW (TEFLON) TAPE

Insulates where slight movement is present. Ideal for instrument panel applications.

SILICONE GREASE

Used in place of UHMW tape that is be visible or does not fit. Will only last a few months.

SILICONE SPRAY

Used when grease cannot be applied.

DUCT TAPE

Used to eliminate movement.

CONFIRM THE REPAIR

Confirm that the cause of a noise is repaired by test driving the vehicle. Operate the vehicle under the same conditions as when the noise originally occurred. Refer to the notes on the Diagnostic Worksheet.

Inspection Procedure

INFOID:000000007769486

Refer to Table of Contents for specific component removal and installation information.

INSTRUMENT PANEL

Most incidents are caused by contact and movement between:

1. The cluster lid A and instrument panel
2. Acrylic lens and combination meter housing
3. Instrument panel to front pillar garnish
4. Instrument panel to windshield
5. Instrument panel mounting pins
6. Wiring harnesses behind the combination meter
7. A/C defroster duct and duct joint

These incidents can usually be located by tapping or moving the components to duplicate the noise or by pressing on the components while driving to stop the noise. Most of these incidents can be repaired by applying felt cloth tape or silicon spray (in hard to reach areas). Urethane pads can be used to insulate wiring harness.

CAUTION:

Never use silicone spray to isolate a squeak or rattle. If the area is saturated with silicone, the recheck of repair becomes impossible.

CENTER CONSOLE

Components to pay attention to include:

1. Shifter assembly cover to finisher
2. A/C control unit and cluster lid C
3. Wiring harnesses behind audio and A/C control unit

The instrument panel repair and isolation procedures also apply to the center console.

DOORS

Pay attention to the following:

1. Finisher and inner panel making a slapping noise
2. Inside handle escutcheon to door finisher
3. Wiring harnesses tapping
4. Door striker out of alignment causing a popping noise on starts and stops

Tapping or moving the components or pressing on them while driving to duplicate the conditions can isolate many of these incidents. The areas can usually be insulated with felt cloth tape or insulator foam blocks from the Nissan Squeak and Rattle Kit (J-43980) to repair the noise.

TRUNK

Trunk noises are often caused by a loose jack or loose items put into the trunk by the customer.

In addition look for the following:

1. Trunk lid dumpers out of adjustment
2. Trunk lid striker out of adjustment

SQUEAK AND RATTLE TROUBLE DIAGNOSES

< SYMPTOM DIAGNOSIS >

3. The trunk lid torsion bars knocking together

4. A loose license plate or bracket

Most of these incidents can be repaired by adjusting, securing or insulating the item(s) or component(s) causing the noise.

SUNROOF/HEADLINING

Noises in the sunroof/headlining area can often be traced to one of the following:

1. Sunroof lid, rail, linkage or seals making a rattle or light knocking noise

2. Sunvisor shaft shaking in the holder

3. Front or rear windshield touching headlining and squeaking

Again, pressing on the components to stop the noise while duplicating the conditions can isolate most of these incidents. Repairs usually consist of insulating with felt cloth tape.

SEATS

When isolating seat noise it's important to note the position the seats in and the load placed on the seat when the noise occurs. These conditions should be duplicated when verifying and isolating the cause of the noise.

Cause of seat noise include:

1. Headrest rods and holder

2. A squeak between the seat pad cushion and frame

3. The rear seatback lock and bracket

These noises can be isolated by moving or pressing on the suspected components while duplicating the conditions under which the noise occurs. Most of these incidents can be repaired by repositioning the component or applying urethane tape to the contact area.

UNDERHOOD

Some interior noise may be caused by components under the hood or on the engine wall. The noise is then transmitted into the passenger compartment.

Causes of transmitted underhood noise include:

1. Any component mounted to the engine wall

2. Components that pass through the engine wall

3. Engine wall mounts and connectors

4. Loose radiator mounting pins

5. Hood bumpers out of adjustment

6. Hood striker out of adjustment

These noises can be difficult to isolate since they cannot be reached from the interior of the vehicle. The best method is to secure, move or insulate one component at a time and test drive the vehicle. Also, engine RPM or load can be changed to isolate the noise. Repairs can usually be made by moving, adjusting, securing, or insulating the component causing the noise.

A

B

C

D

E

F

G

H

I

J

EXT

L

M

N

O

P

SQUEAK AND RATTLE TROUBLE DIAGNOSES

< SYMPTOM DIAGNOSIS >

Diagnostic Worksheet

INFOID:000000007769487



SQUEAK & RATTLE DIAGNOSTIC WORKSHEET

Dear Nissan Customer:

We are concerned about your satisfaction with your Nissan vehicle. Repairing a squeak or rattle sometimes can be very difficult. To help us fix your Nissan right the first time, please take a moment to note the area of the vehicle where the squeak or rattle occurs and under what conditions. You may be asked to take a test drive with a service advisor or technician to ensure we confirm the noise you are hearing.

I. WHERE DOES THE NOISE COME FROM? (circle the area of the vehicle)

The illustrations are for reference only, and may not reflect the actual configuration of your vehicle.

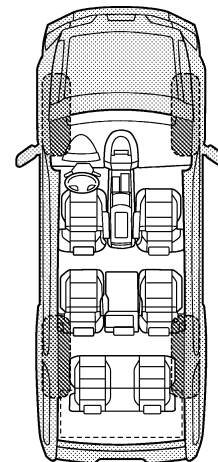
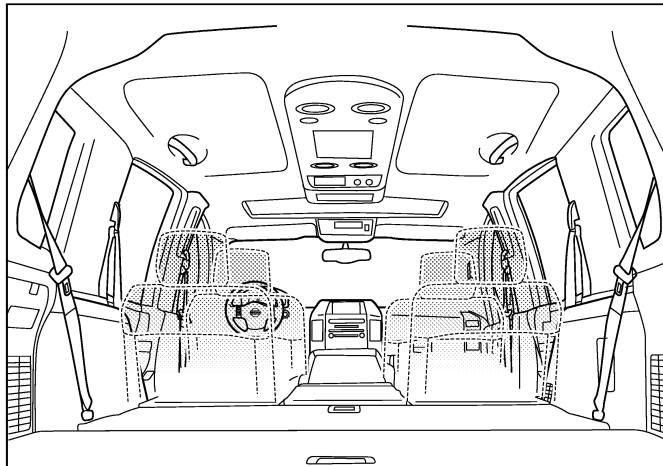
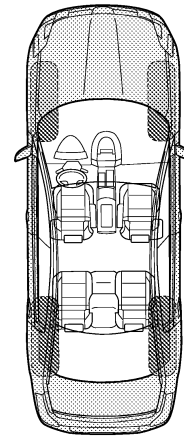
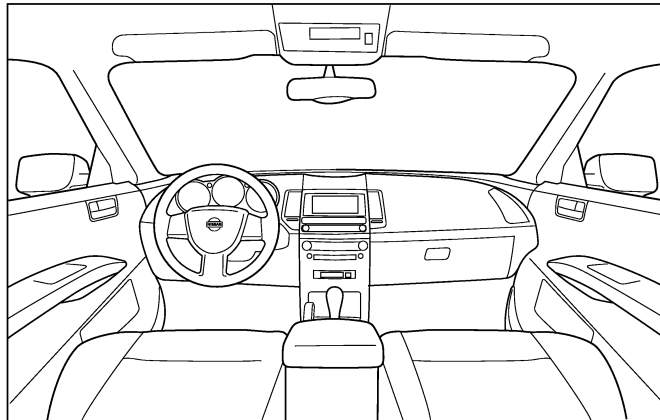

Continue to page 2 of the worksheet and briefly describe the location of the noise or rattle. In addition, please indicate the conditions which are present when the noise occurs.

PIIB8740E

SQUEAK AND RATTLE TROUBLE DIAGNOSES

< SYMPTOM DIAGNOSIS >

SQUEAK & RATTLE DIAGNOSTIC WORKSHEET - page 2

Briefly describe the location where the noise occurs:

II. WHEN DOES IT OCCUR? (please check the boxes that apply)

- | | |
|---|--|
| <input type="checkbox"/> anytime | <input type="checkbox"/> after sitting out in the rain |
| <input type="checkbox"/> 1st time in the morning | <input type="checkbox"/> when it is raining or wet |
| <input type="checkbox"/> only when it is cold outside | <input type="checkbox"/> dry or dusty conditions |
| <input type="checkbox"/> only when it is hot outside | <input type="checkbox"/> other: |

III. WHEN DRIVING:

- through driveways
- over rough roads
- over speed bumps
- only about ____ mph
- on acceleration
- coming to a stop
- on turns: left, right or either (circle)
- with passengers or cargo
- other: _____
- after driving ____ miles or ____ minutes

IV. WHAT TYPE OF NOISE

- squeak (like tennis shoes on a clean floor)
- creak (like walking on an old wooden floor)
- rattle (like shaking a baby rattle)
- knock (like a knock at the door)
- tick (like a clock second hand)
- thump (heavy, muffled knock noise)
- buzz (like a bumble bee)

TO BE COMPLETED BY DEALERSHIP PERSONNEL

Test Drive Notes:

	YES	NO	Initials of person performing
Vehicle test driven with customer	<input type="checkbox"/>	<input type="checkbox"/>	_____
- Noise verified on test drive	<input type="checkbox"/>	<input type="checkbox"/>	_____
- Noise source located and repaired	<input type="checkbox"/>	<input type="checkbox"/>	_____
- Follow up test drive performed to confirm repair	<input type="checkbox"/>	<input type="checkbox"/>	_____

VIN: _____ Customer Name: _____
W.O.# _____ Date: _____

This form must be attached to Work Order

PIIB8742E

A
B
C
D
E
F
G
H
I
J
L
M
N
O
P

EXT

PRECAUTIONS

< PRECAUTION >

PRECAUTION

PRECAUTIONS

Precaution for Supplemental Restraint System (SRS) "AIR BAG" and "SEAT BELT PRE-TENSIONER"

INFOID:000000007769488

The Supplemental Restraint System such as "AIR BAG" and "SEAT BELT PRE-TENSIONER", used along with a front seat belt, helps to reduce the risk or severity of injury to the driver and front passenger for certain types of collision. This system includes seat belt switch inputs and dual stage front air bag modules. The SRS system uses the seat belt switches to determine the front air bag deployment, and may only deploy one front air bag, depending on the severity of a collision and whether the front occupants are belted or unbelted. Information necessary to service the system safely is included in the "SRS AIR BAG" and "SEAT BELT" of this Service Manual.

WARNING:

Always observe the following items for preventing accidental activation.

- To avoid rendering the SRS inoperative, which could increase the risk of personal injury or death in the event of a collision that would result in air bag inflation, all maintenance must be performed by an authorized NISSAN/INFINITI dealer.
- Improper maintenance, including incorrect removal and installation of the SRS, can lead to personal injury caused by unintentional activation of the system. For removal of Spiral Cable and Air Bag Module, see "SRS AIR BAG".
- Never use electrical test equipment on any circuit related to the SRS unless instructed to in this Service Manual. SRS wiring harnesses can be identified by yellow and/or orange harnesses or harness connectors.

PRECAUTIONS WHEN USING POWER TOOLS (AIR OR ELECTRIC) AND HAMMERS

WARNING:

Always observe the following items for preventing accidental activation.

- When working near the Air Bag Diagnosis Sensor Unit or other Air Bag System sensors with the ignition ON or engine running, never use air or electric power tools or strike near the sensor(s) with a hammer. Heavy vibration could activate the sensor(s) and deploy the air bag(s), possibly causing serious injury.
- When using air or electric power tools or hammers, always switch the ignition OFF, disconnect the battery, and wait at least 3 minutes before performing any service.

Precautions Necessary for Steering Wheel Rotation After Battery Disconnection

INFOID:000000007769489

CAUTION:

Comply with the following cautions to prevent any error and malfunction.

- Before removing and installing any control units, first turn the ignition switch to the LOCK position, then disconnect both battery cables.
- After finishing work, confirm that all control unit connectors are connected properly, then re-connect both battery cables.
- Always use CONSULT to perform self-diagnosis as a part of each function inspection after finishing work. If a DTC is detected, perform trouble diagnosis according to self-diagnosis results.

For vehicle with steering lock unit, if the battery is disconnected or discharged, the steering wheel will lock and cannot be turned.

If turning the steering wheel is required with the battery disconnected or discharged, follow the operation procedure below before starting the repair operation.

OPERATION PROCEDURE

1. Connect both battery cables.

NOTE:

Supply power using jumper cables if battery is discharged.

2. Turn the ignition switch to ACC position.
(At this time, the steering lock will be released.)
3. Disconnect both battery cables. The steering lock will remain released with both battery cables disconnected and the steering wheel can be turned.

PRECAUTIONS

< PRECAUTION >

4. Perform the necessary repair operation.
5. When the repair work is completed, re-connect both battery cables. With the brake pedal released, turn the ignition switch from ACC position to ON position, then to LOCK position. (The steering wheel will lock when the ignition switch is turned to LOCK position.)
6. Perform self-diagnosis check of all control units using CONSULT.

Precaution for Procedure without Cowl Top Cover

INFOID:000000007769490

When performing the procedure after removing cowl top cover, cover the lower end of windshield with urethane, etc to prevent damage to windshield.

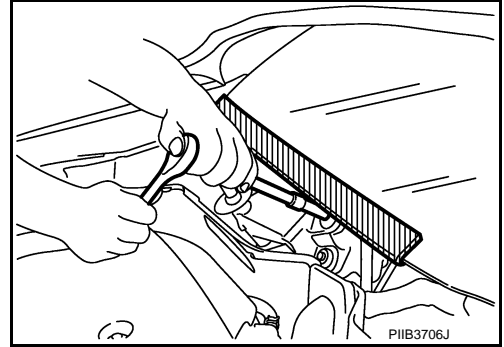

Precaution for Work

INFOID:000000007769491

- After removing and installing the opening/closing parts, be sure to carry out fitting adjustments to check their operation.
- Check the lubrication level, damage, and wear of each part. If necessary, grease or replace it.

A
B
C
D
E
F
G
H
I
J
L
M
N
O
P

EXT

PREPARATION

< PREPARATION >

PREPARATION

PREPARATION

Special Service Tools

INFOID:000000007769492

The actual shapes of Kent-Moore tools may differ from those of special service tools illustrated here.

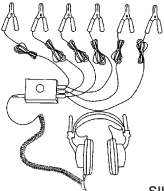
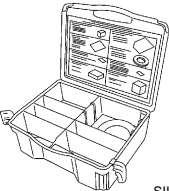
	Tool number (Kent-Moore No.) Tool name	Description
(J-39570) Chassis ear	 <p>SIIA0993E</p>	Locates the noise
(J-43980) NISSAN Squeak and Rattle Kit	 <p>SIIA0994E</p>	Repairs the cause of noise

Commercial Service Tools

INFOID:000000007769493

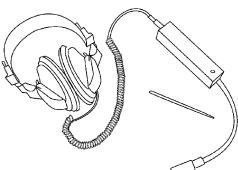
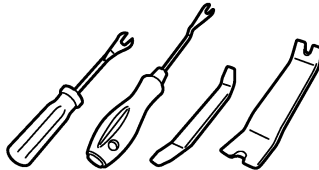
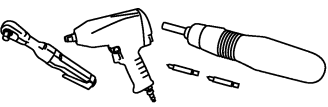
	Tool name	Description
Engine ear	 <p>SIIA0995E</p>	Locates the noise
Remover tool	 <p>JMKIA3050ZZ</p>	Removes clips, pawls, and metal clips
Power tool	 <p>PIIIB1407E</p>	

FRONT BUMPER

< REMOVAL AND INSTALLATION >

REMOVAL AND INSTALLATION

FRONT BUMPER

Exploded View

INFOID:000000007769494

SEC. 620

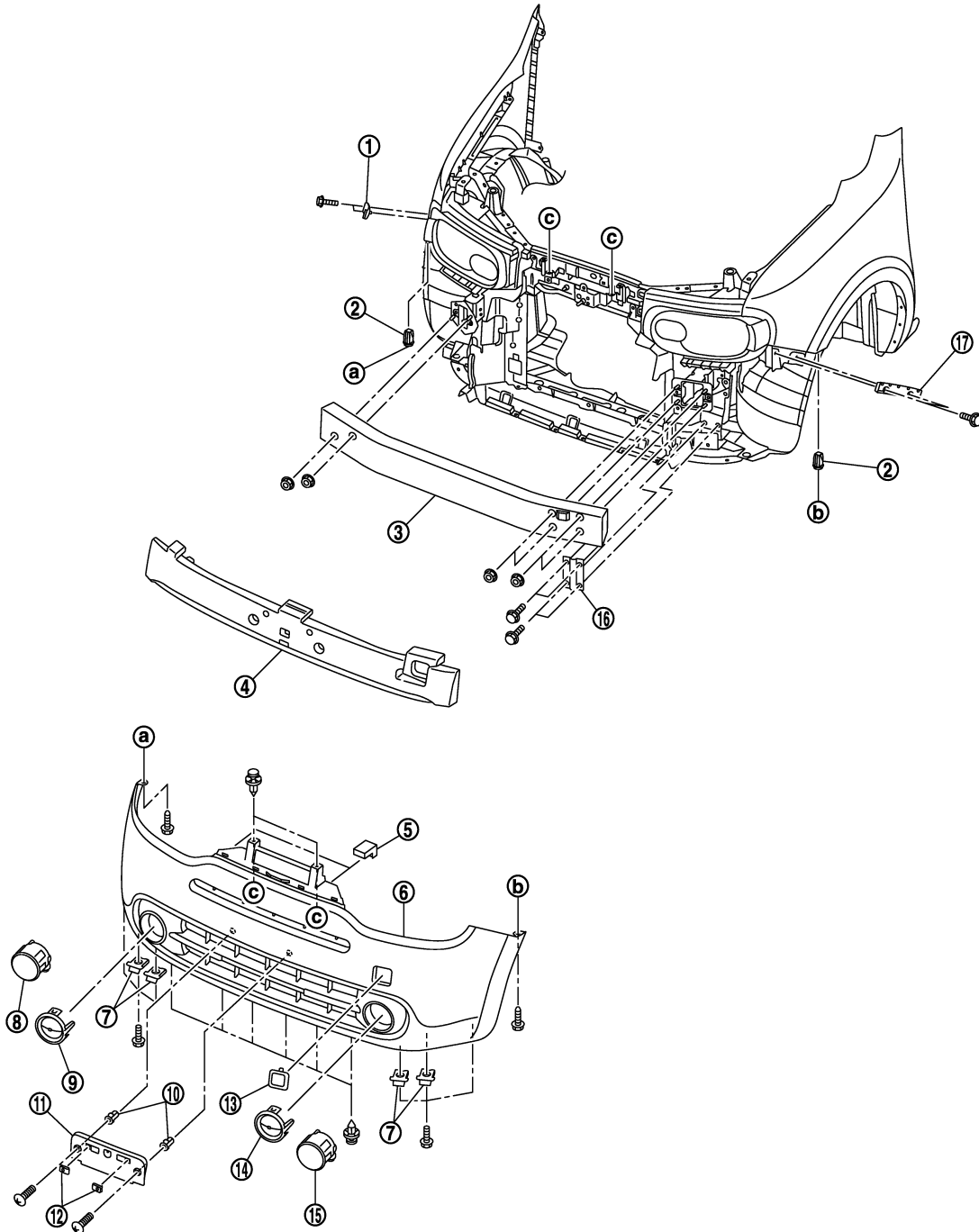

A
B
C
D
E
F
G
H
I
J
EXT
L
M
N
O
P

JMKIA4087ZZ

FRONT BUMPER

< REMOVAL AND INSTALLATION >

- | | | |
|------------------------------|----------------------------|-------------------------|
| 1. Bumper side bracket RH | 2. Grommet | 3. Bumper reinforcement |
| 4. Bumper energy absorber | 5. Spacer | 6. Bumper fascia |
| 7. J nut | 8. Front fog lamp RH | 9. Bumper finisher RH |
| 10. Screw grommet | 11. License plate bracket | 12. J nut |
| 13. Bumper bracket cover | 14. Bumper finisher LH | 15. Front fog lamp LH |
| 16. Radiator core lower stay | 17. Bumper side bracket LH | |

Removal and Installation

INFOID:000000007769495

REMOVAL

CAUTION:

Bumper fascia is made of resin. Never apply strong force to it, and be careful to prevent contact with oil.

1. Fully open hood assembly.
2. Remove front grille. Refer to [EXT-17. "Removal and Installation"](#).
3. Remove fender protector fixing clips and screws to access bumper fascia assembly fixing screw, and then remove bumper fascia assembly fixing screws (LH/RH).
4. Remove bumper fascia assembly lower side fixing bolts and clips.
5. Pull bumper fascia assembly side toward the vehicle side as shown by the arrows in the figure, and then disengage bumper fascia assembly from bumper side brackets (LH/RH).

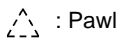

: Pawl

CAUTION:

When removing bumper fascia, 2 workers are required so as to prevent it from dropping.

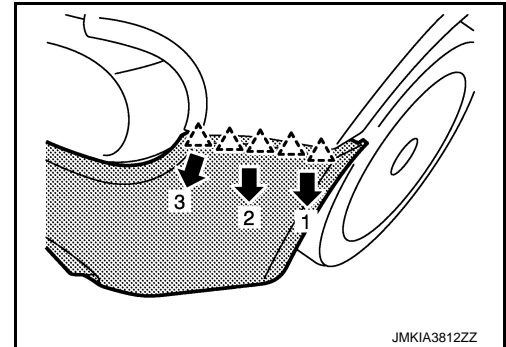

JMKIA3812ZZ

6. Disconnect front fog lamp harness connectors (LH/RH).
7. Remove bumper fascia assembly.

CAUTION:

When removing bumper fascia, 2 workers are required so as to prevent it from dropping.

8. Remove the following parts after removing bumper fascia.
 - License plate bracket
 - Front bumper side brackets (LH/RH)
 - Front bumper finishers (LH/RH) (without front fog lamp models)
 - Fog lamps (LH/RH). Refer to [EXL-171. "Removal and Installation"](#).
 - Bumper spacers
9. Remove bumper energy absorber.
10. Remove bumper reinforcement.
 - Remove radiator core lower stay mounting bolts (A), and then remove radiator core lower stay.

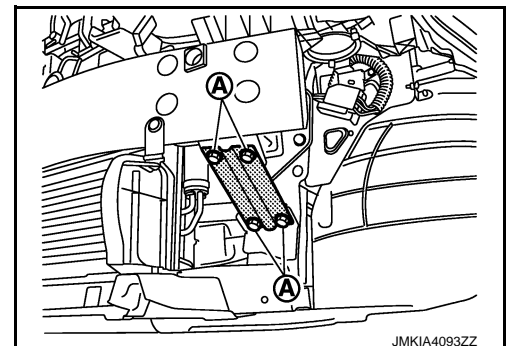

JMKIA4093ZZ

- Remove bumper reinforcement fixing nuts.
- Partially remove bumper reinforcement right side.

FRONT BUMPER

< REMOVAL AND INSTALLATION >

- Tilt bumper reinforcement (1) as shown by the arrow in the figure, and then partially remove bumper reinforcement left side.

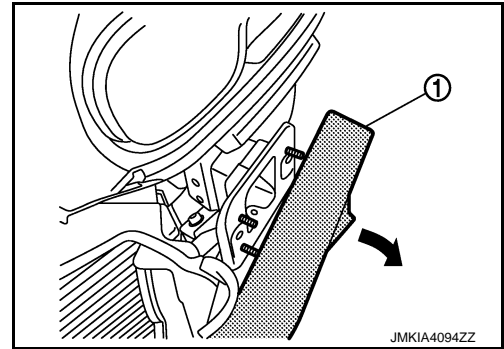

- Tilt and remove bumper reinforcement, so that bumper reinforcement bracket (1) does not interfere to bumper stay (2) as shown in the figure.

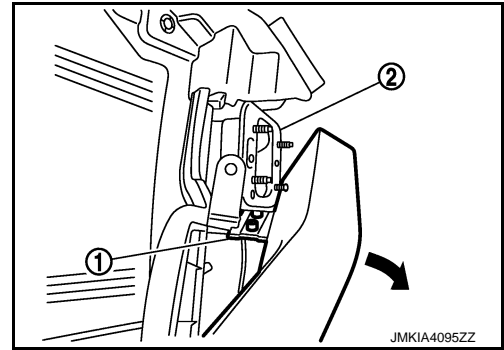

INSTALLATION

Install in the reverse order of removal.

NOTE:

After installing, perform fitting adjustment.

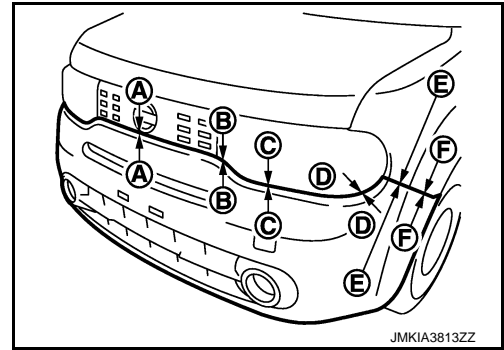

Portion		Clearance	Surface height difference
Front bumper – Front grille	A – A	0.1 – 3.0 mm (0.039 – 0.118 in)	—
	B – B	0.0 – 3.0 mm (0.000 – 0.118 in)	—
Front bumper – Headlamp	C – C	0.3 – 3.3 mm (0.012 – 0.130 in)	—
	D – D	0.2 – 3.2 mm (0.008 – 0.126 in)	—
Front bumper – Front fender	E – E	0.0 – 0.8 mm (0.000 – 0.031 in)	- 0.3 – 1.7 mm (- 0.012 – 0.067 in)
	F – F	0.0 – 0.8 mm (0.000 – 0.031 in)	- 0.3 – 1.7 mm (- 0.012 – 0.067 in)

A
B
C
D
E
F
G
H
I
J
EXT
L
M
N
O
P

REAR BUMPER

< REMOVAL AND INSTALLATION >

REAR BUMPER

Exploded View

INFOID:000000007769496

SEC. 850

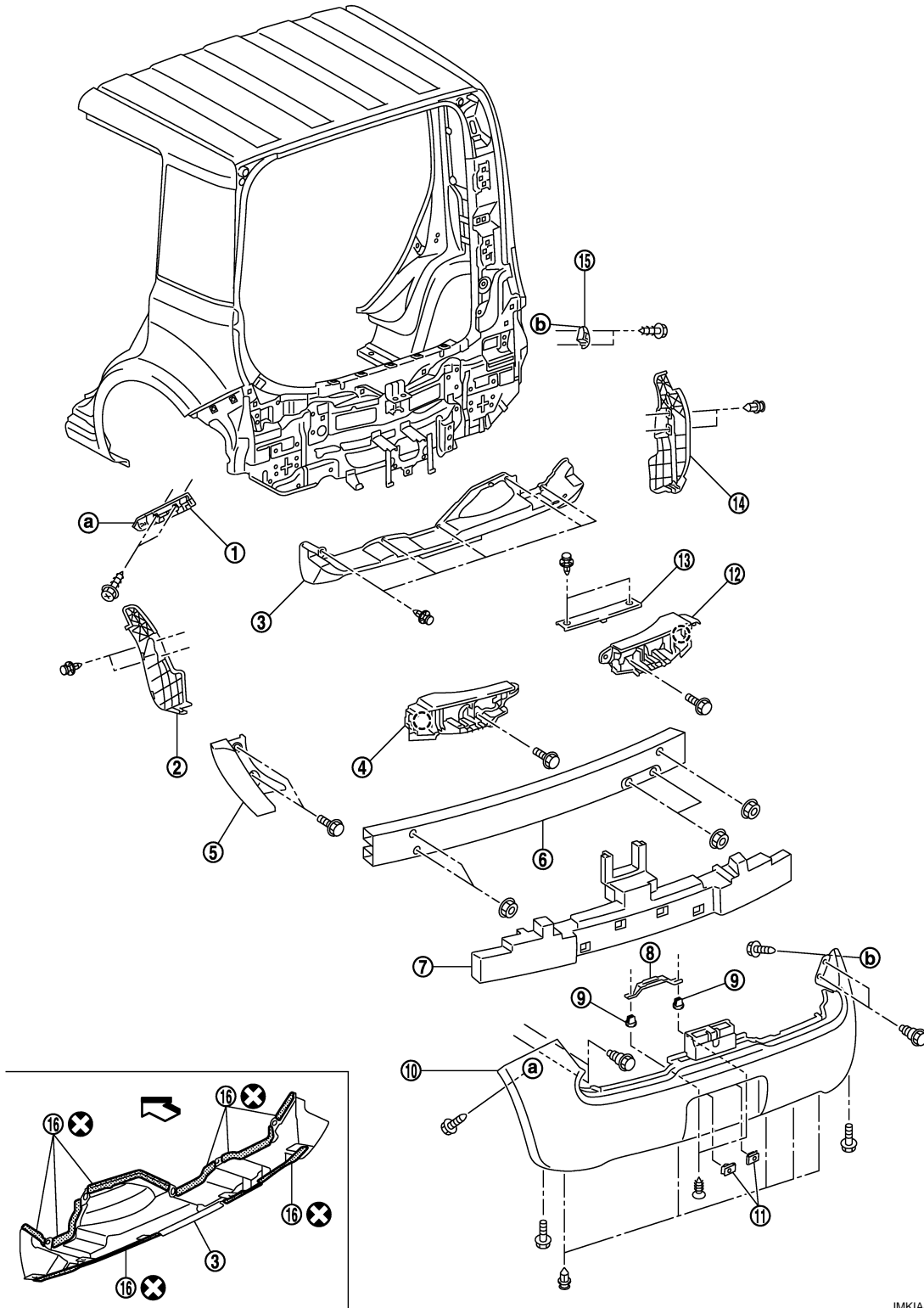

JMKIA4088ZZ

- | | | |
|---------------------------|-------------------------|-------------------------|
| 1. Bumper side bracket LH | 2. Bumper closing LH | 3. Rear panel lower |
| 4. Bumper bracket LH | 5. Rear fender cover | 6. Bumper reinforcement |
| 7. Bumper energy absorber | 8. License lamp bracket | 9. Grommet |

REAR BUMPER

< REMOVAL AND INSTALLATION >

- | | | |
|------------------------------------|-----------------------|----------------------------|
| 10. Bumper fascia | 11. J nut | 12. Bumper bracket RH |
| 13. Rear bumper cover | 14. Bumper closing RH | 15. Bumper side bracket RH |
| 16. EPT sealer [3.0 mm (0.118 in)] | | |

↩ : Vehicle front

Refer to [GI-4. "Components"](#) for symbols in the figure.

Removal and Installation

INFOID:000000007769497

REMOVAL

CAUTION:

Bumper fascia is made of resin. Never apply strong force to it, and be careful to prevent contact with oil.

1. Fully open back door.
2. Remove rear bumper cover.
3. Remove back door finisher and rear combination lamp (LH/RH). Refer to [EXL-178. "Removal and Installation"](#).
4. Remove rear fender cover.
5. Disconnect harness connector (A).

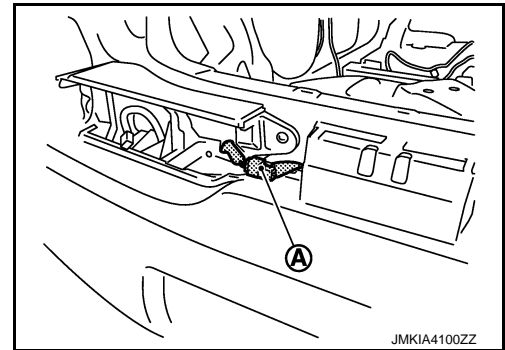

6. Remove bumper fascia upper mounting bolts (LH/RH).
7. Remove bumper fascia lower fixing clips.
8. Remove bumper fascia both ends fixing screws.
9. Disengage bumper fascia and rear panel lower connecting portion (A).

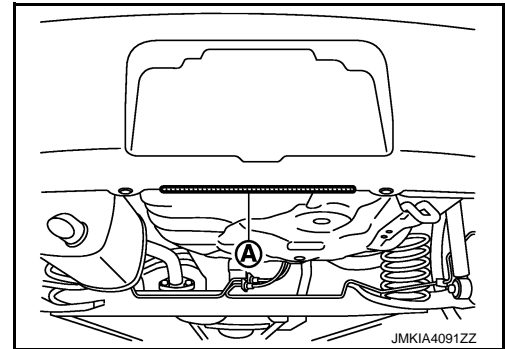

10. Pull bumper fascia assembly toward the vehicle out side as shown by the arrows in the figure, and then disengage the bumper fascia assembly from bumper side brackets (LH/RH).

△ : Pawl

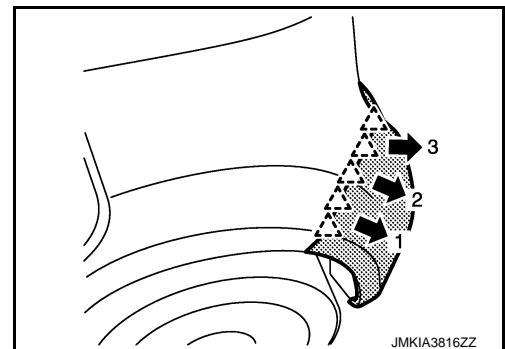

A
B
C
D
E
F
G
H
I
J
EXT
L
M
N
O
P

REAR BUMPER

< REMOVAL AND INSTALLATION >

11. Remove bumper fascia assembly.

CAUTION:

When removing bumper fascia, 2 workers are required so as to prevent it from dropping.

12. Remove the following parts after removing bumper fascia.

- Rear side marker lamps (LH/RH). Refer to [EXL-181, "Removal and Installation"](#).
- Bumper closings (LH/RH)
- Bumper side brackets (LH/RH)
- Bumper sub harness

13. Remove bumper energy absorber.

14. Remove bumper reinforcement mounting nuts, and then remove bumper reinforcement with power tool.

INSTALLATION

Install in the reverse order of removal.

NOTE:

After installing, perform fitting adjustment.

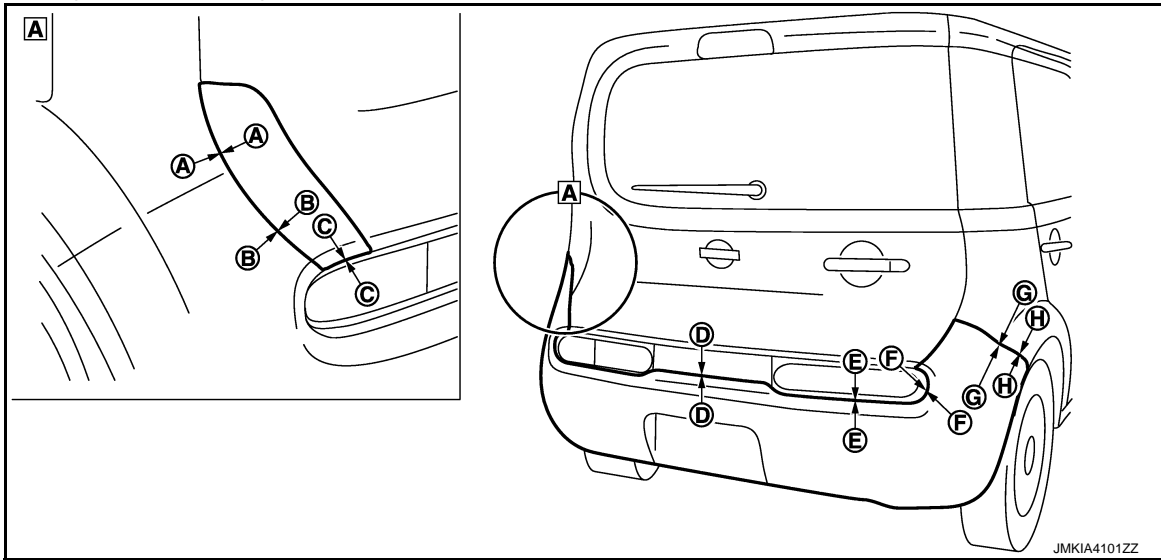

Portion		Clearance	Surface height difference
Rear fender cover – Rear fender	A – A	0.0 – 1.0 mm (0.000 – 0.039 in)	- 0.5 – 1.9 mm (- 0.020 – 0.075 in)
Rear fender cover – Rear bumper	B – B	0.0 – 1.0 mm (0.000 – 0.039 in)	- 1.3 – 1.3 mm (- 0.051 – 0.051 in)
Rear fender cover – Rear combination lamp	C – C	5.4 – 8.6 mm (0.213 – 0.339 in)	—
Rear bumper – Back door finisher	D – D	0.4 – 3.6 mm (0.016 – 0.142 in)	
Rear fender cover – Rear combination lamp	E – E	0.5 – 3.5 mm (0.020 – 0.138 in)	—
	F – F	2.0 – 5.0 mm (0.079 – 0.197 in)	—
Rear bumper – Rear fender	G – G	0.0 – 0.9 mm (0.000 – 0.035 in)	- 0.3 – 1.7 mm (- 0.012 – 0.067 in)
	H – H	0.0 – 0.9 mm (0.000 – 0.035 in)	- 0.3 – 1.7 mm (- 0.012 – 0.067 in)

FRONT GRILLE

< REMOVAL AND INSTALLATION >

FRONT GRILLE

Exploded View

INFOID:000000007769498

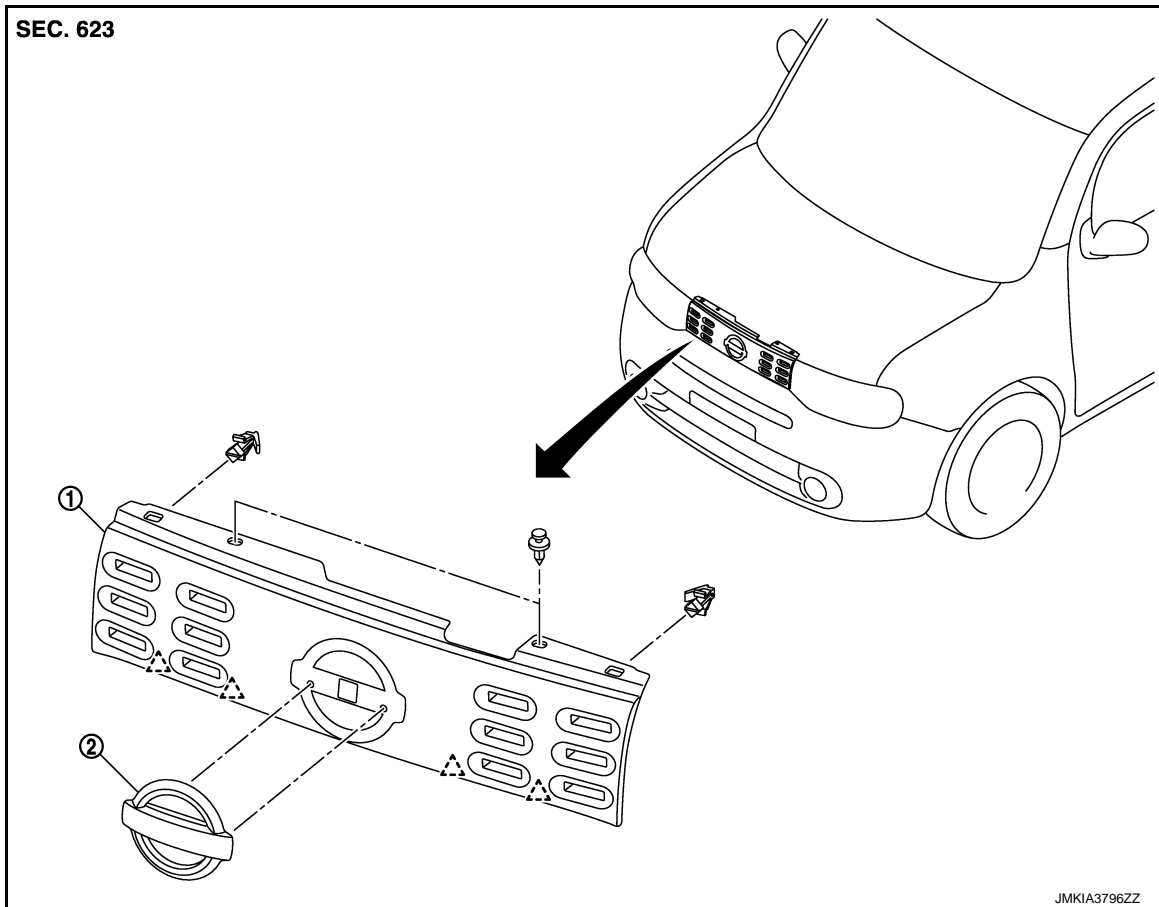

1. Front grille

2. Front emblem

△ : Pawl

Removal and Installation

INFOID:000000007769499

REMOVAL

1. Fully open hood.
2. Remove front grille upper side fixing clips.
3. Disengage front grille mounting clips (B) by rotating 45° using a flat-bladed screwdriver (A) through access hole of front grille (1) upper while pulling front grill toward vehicle front.

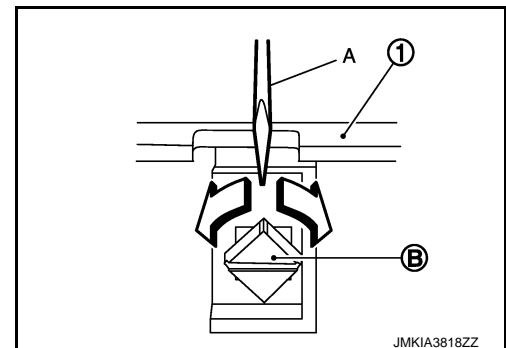

4. Remove bumper fascia upper fixing clips.
5. Disengage front grille fixing pawls from back side of front grille while pull front grille horizontally toward vehicle front, and then remove front grille.

A
B
C
D
E
F
G
H
I
J

EXT

L
M
N
O
P

FRONT GRILLE

< REMOVAL AND INSTALLATION >

6. Remove the front emblem after removing front grille.

INSTALLATION

Install in the reverse order of removal.

COWL TOP

< REMOVAL AND INSTALLATION >

COWL TOP

Exploded View

INFOID:000000007769500

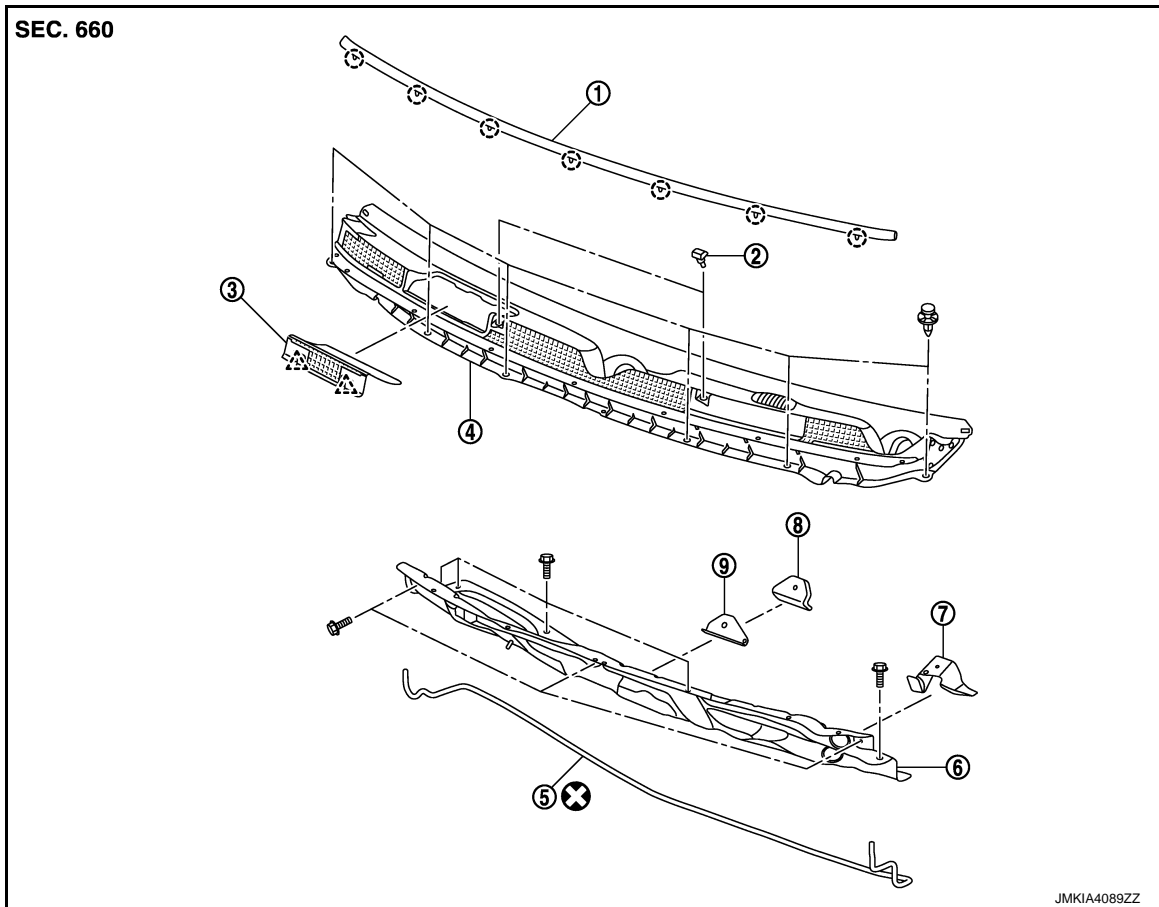

- | | | |
|------------------------|-----------------------------------|------------------------------|
| 1. Cowl top cover seal | 2. Washer nozzle | 3. Cowl top cover cap |
| 4. Cowl top cover | 5. EPT sealer [3.0 mm (0.118 in)] | 6. Cowl top extension |
| 7. Wiper motor bracket | 8. Wiper pivot bracket rear | 9. Wiper pivot bracket front |

○ : Clip

△ : Pawl

Refer to [GI-4. "Components"](#) for symbols in the figure.

Removal and Installation

INFOID:000000007769501

REMOVAL

1. Fully open hood assembly.
2. Remove front wiper arm, and blades (LH/RH). Refer to [WW-125. "Removal and Installation"](#).
3. Remove front fender cover. Refer to [DLK-164. "Removal and Installation"](#).
4. Remove cowl top cover fixing clips.

A
B
C
D
E
F
G
H
I
J

EXT

L

M

N

O

P

COWL TOP

< REMOVAL AND INSTALLATION >

5. Pull forward to release cowl top cover from windshield glass.

CAUTION:

When performing the procedure after removing cowl top cover, cover the lower and of windshield glass with urethane etc.

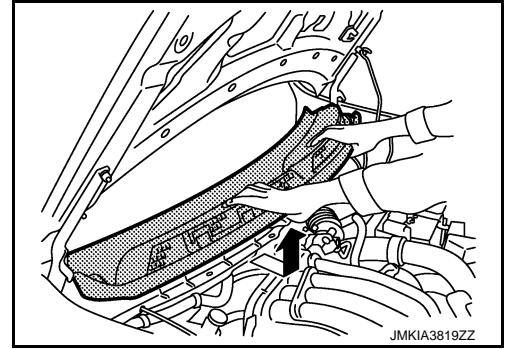

6. Disconnect wind washer tube connector.
7. Remove cowl top cover.
8. Remove the following parts after removing cowl top cover.
 - EPT sealer
 - Cowl top cover seal
 - Washer tube
 - Washer nozzles. Refer to [WW-122, "Removal and Installation"](#).
9. Remove front wiper drive assembly. Refer to [WW-127, "Removal and Installation"](#).
10. Remove cowl top extension mounting bolts, and them cowl top extension.

INSTALLATION

Install in the reverse order of removal.

CAUTION:

- Always replace cowl top cover EPT sealer on rear of vehicle with a new one when installing old cowl top cover.
- After installing, perform adjustment of wiper arm. Refer to [WW-125, "Adjustment"](#).

FENDER PROTECTOR

< REMOVAL AND INSTALLATION >

FENDER PROTECTOR

FENDER PROTECTOR

FENDER PROTECTOR : Exploded View

INFOID:000000007769502

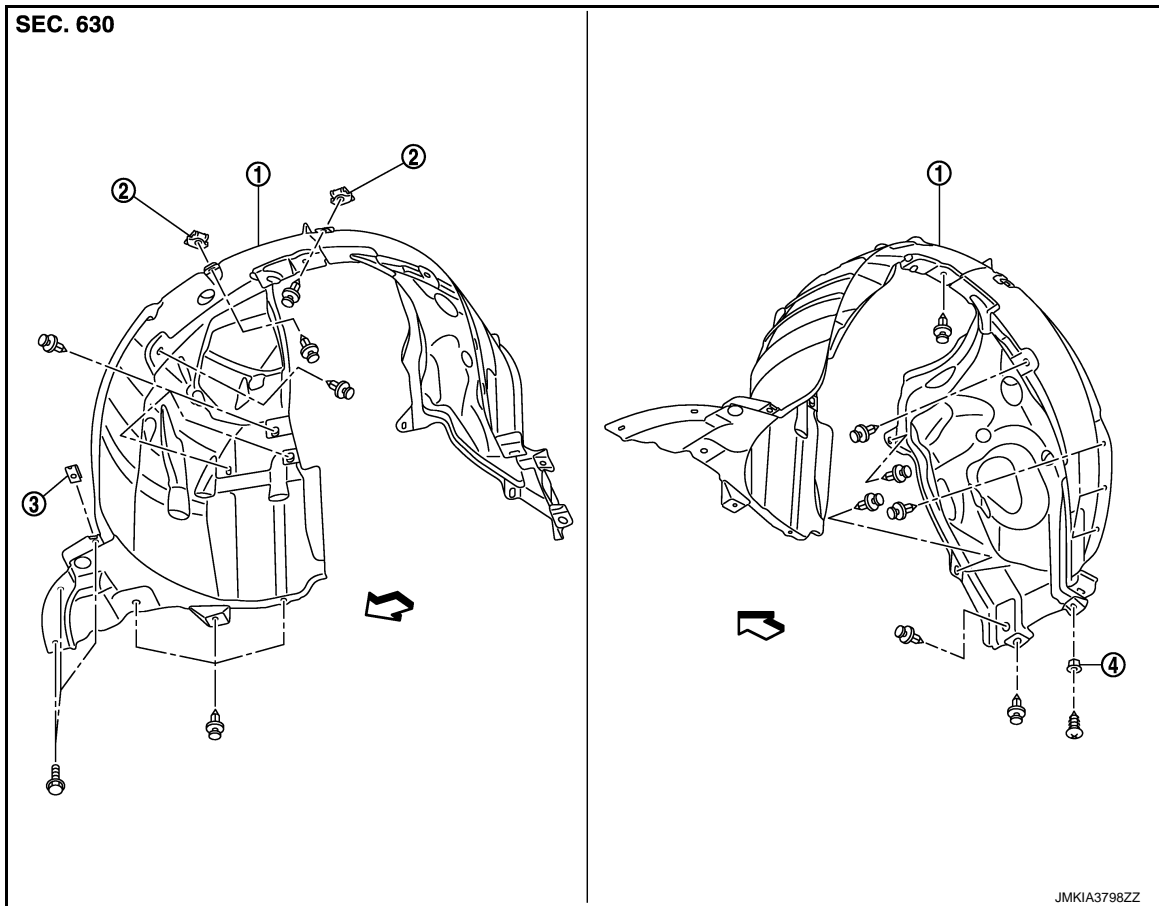

1. Fender protector

2. Fender clip

3. J nut

4. Grommet

← : Vehicle front

FENDER PROTECTOR : Removal and Installation

INFOID:000000007769503

REMOVAL

1. Remove front tire.
2. Remove front fender protector fixing screws, bolts and clips.
3. Disengage fender clips and fender protector, and then remove fender protector.

INSTALLATION

Install in the reverse order of removal.

FLOOR SIDE FAIRING

< REMOVAL AND INSTALLATION >

FLOOR SIDE FAIRING

Exploded View

INFOID:000000007769504

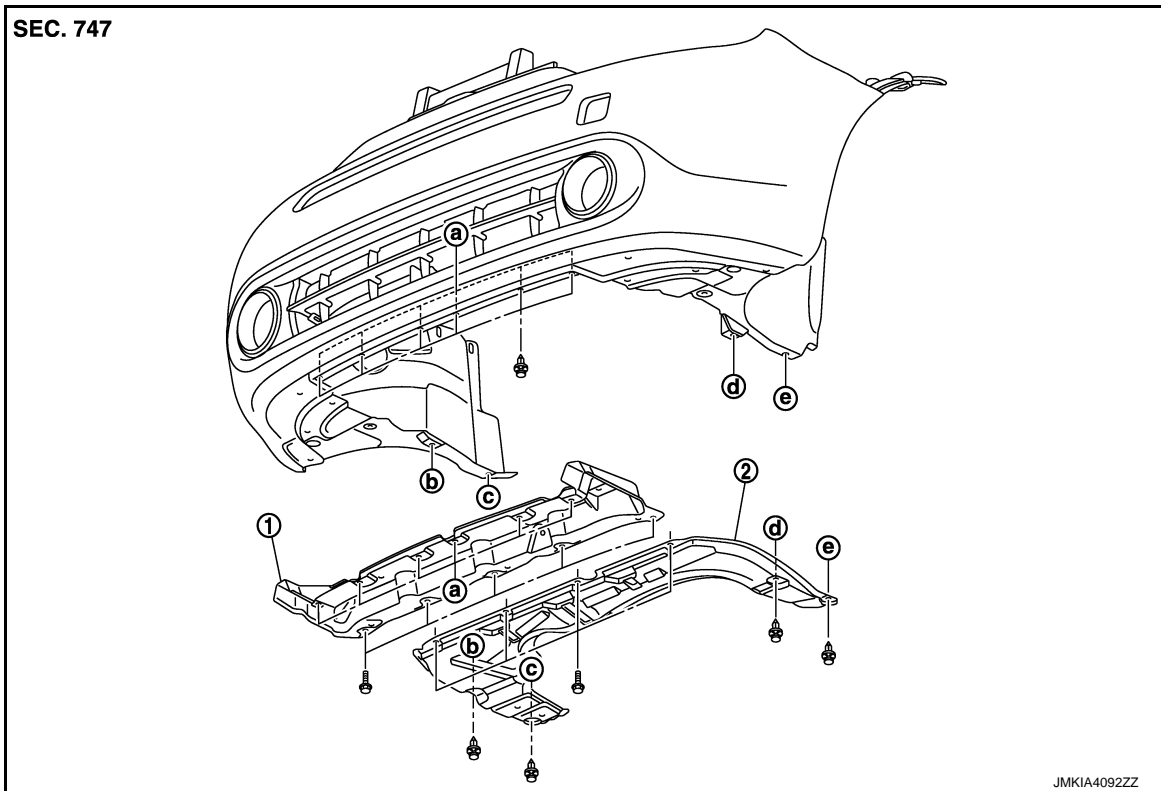

1. Front under cover front

2. Front under cover

Removal and Installation

INFOID:000000007769505

REMOVAL

FRONT UNDER COVER FRONT

1. Remove bumper fascia assembly. Refer to [EXT-12. "Removal and Installation"](#).
2. Remove front under cover front mounting bolts.
3. Remove front under cover front.

FRONT UNDER COVER

1. Remove front under cover mounting bolts and clips.
2. Remove front under cover.

INSTALLATION

Install in the reverse order of removal.

ROOF SIDE MOLDING

< REMOVAL AND INSTALLATION >

ROOF SIDE MOLDING

Exploded View

INFOID:000000007769506

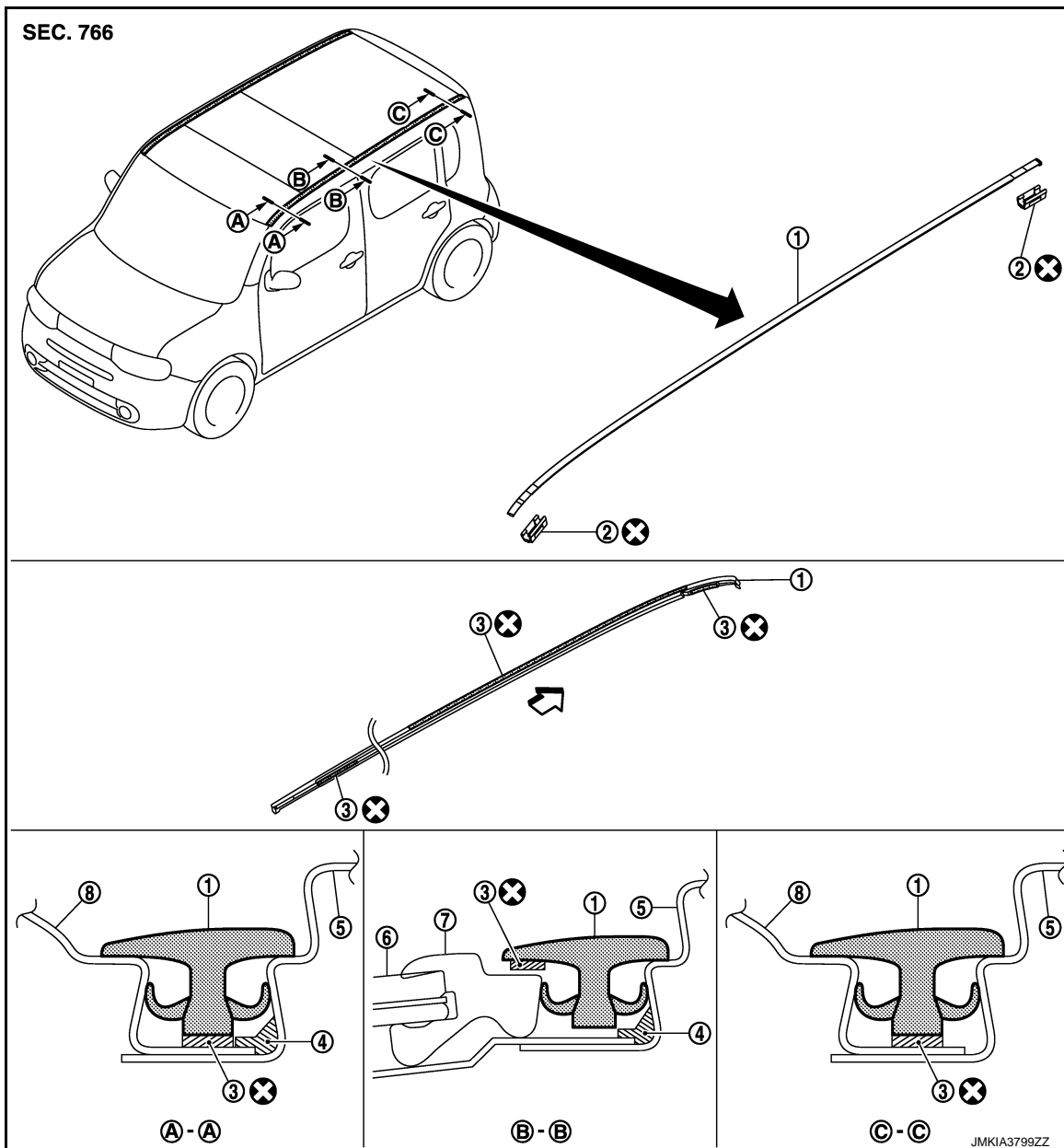

- | | | |
|----------------------|---------------------------|---|
| 1. Roof side molding | 2. Roof side molding clip | 3. Double-faced adhesive tape [1.2 mm (0.047 in)] |
| 4. Paint sealant | 5. Body side outer panel | 6. Stylish glass |
| 7. Glass molding | 8. Roof panel | |

↶ : Vehicle front

Refer to [GI-4, "Components"](#) for symbols in the figure.

Removal and Installation

INFOID:000000007769507

REMOVAL

A
B
C
D
E
F
G
H
I
J
EXT
L
M
N
O
P

ROOF SIDE MOLDING

< REMOVAL AND INSTALLATION >

1. Disengage roof side molding clip and roof side molding from rear end, using remover tool (A).

○ : Clip
⇐ : Vehicle front

CAUTION:

- Apply protective tape (B) on body to protect the painted surface from damage.
- Never use an item as a remover tool that could damage body panel.

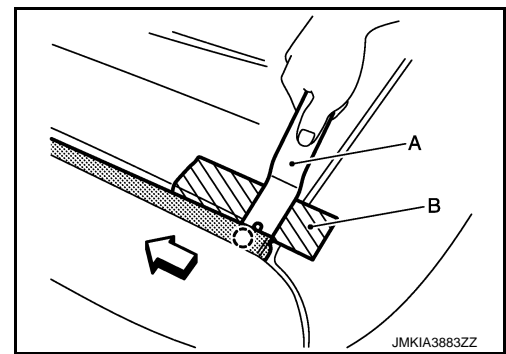

2. Remove roof side molding as shown by the arrow in the figure.

CAUTION:

Never pull the roof side molding strongly.

⇐ : Vehicle front

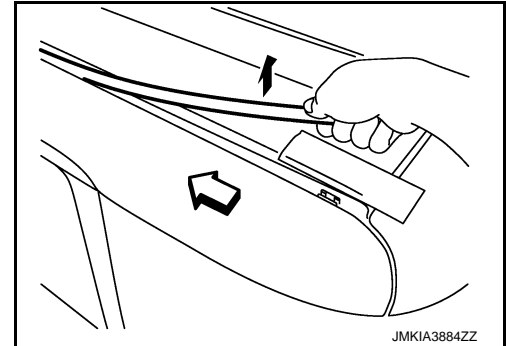

3. Pull out and remove the front end of roof side molding (1) towards vehicle rear after disengaging clip, because the front end is located under the windshield molding (2).

○ : Clip

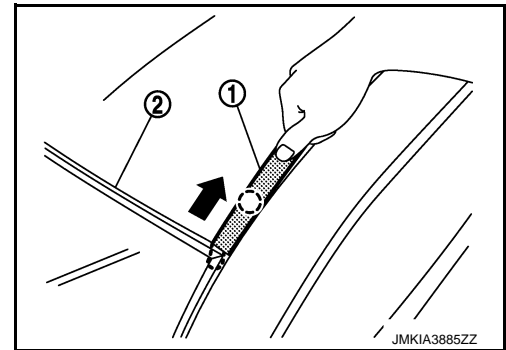

INSTALLATION

Install from roof side molding rear end to front end in this order after temporarily holding.

REMOVAL AND INSTALLATION OF ROOF SIDE MOLDING CLIP

Removal

1. Remove roof side molding.
2. Heat adhesive tape interface using a dryer, and then peel roof side molding clips (body side) using long-nose pliers.

CAUTION:

Be careful not to damage the body.

Installation

1. Clean tape removed surface with a shop cloth soaked in white gasoline or IPA.
2. Use two-part epoxy adhesive.

Adhesive : 3M-weld DP-100 or equivalent

3. Apply adhesive evenly to clip tape surface.

Thickness : Approximately 0.5 mm (0.020 in)

4. Position applied parts to the proper location, and then sufficiently press-fit until the adhesive protrudes to tape side.

ROOF SIDE MOLDING

< REMOVAL AND INSTALLATION >

Press-fit limit : 19.6 N (2.0 Kg - 4.41 lb) × 2 seconds

5. Tape clips after press fit, and temporarily hold it for specified time based on the following.

5 to 10 °C (41 to 50 °F) : 1 hour or more

11 to 23 °C (52 to 73 °F) : 30 minutes or more

24 °C or more (75 °F or more) : 15 minutes or more

6. Install from roof side molding rear end to front end in this order after temporarily holding.

CAUTION:

- Use double-faced adhesive tape after hardening for clips.
- Securely insert molding rear end cap onto roof rear end cutout (installation standard).
- When installing roof side molding of windshield portion, check that molding fastener is securely inserted and then press in.
- Never wash the vehicle with in 24 hours so as to keep adhesive.

A
B
C
D
E
F
G
H
I
J
L
M
N
O
P

EXT

DOOR OUTSIDE MOLDING

< REMOVAL AND INSTALLATION >

DOOR OUTSIDE MOLDING

Exploded View

INFOID:000000007769508

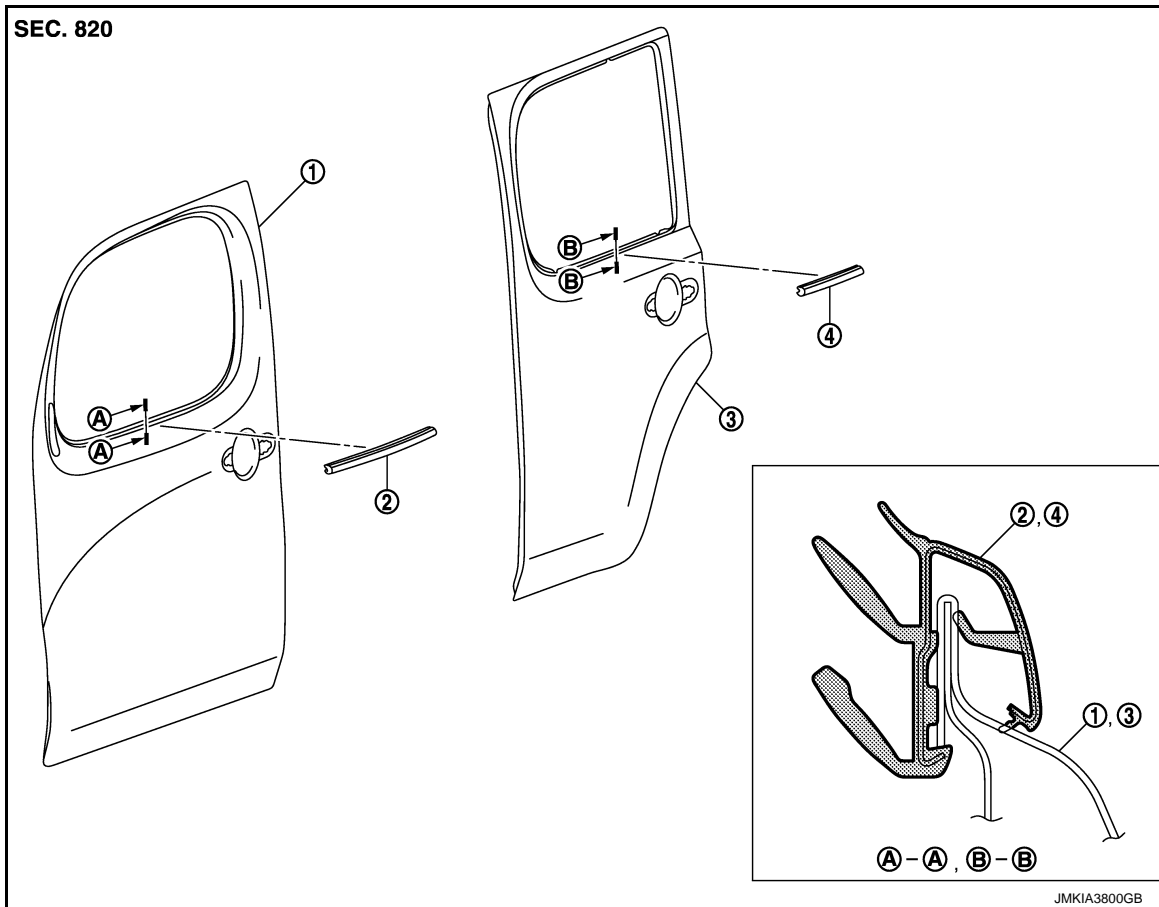

- 1. Front door panel
- 2. Front door outside molding
- 3. Rear door panel
- 4. Rear door outside molding

Removal and Installation

INFOID:000000007769509

REMOVAL

FRONT DOOR OUTSIDE MOLDING

1. Fully open front door glass.
2. Twist door outside molding toward the outside of the vehicle, and then lift up and remove it while disengaging the pawls.

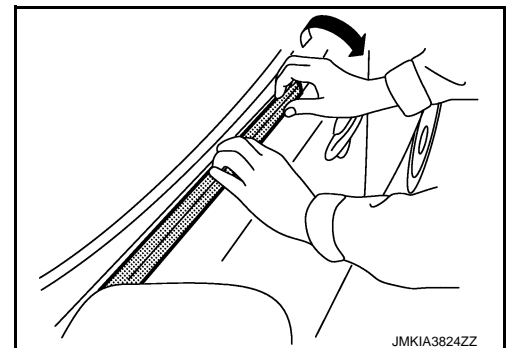

REAR DOOR OUTSIDE MOLDING

1. Fully open door window.

DOOR OUTSIDE MOLDING

< REMOVAL AND INSTALLATION >

2. Twist door outside molding to ward the outside of the vehicle, and then lift up and remove it while disengaging the pawls.

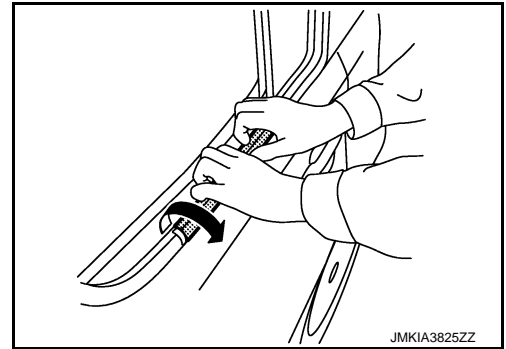

INSTALLATION

Install in the reverse order of removal.

A
B
C
D
E
F
G
H
I
J
L
M
N
O
P

EXT

REAR PILLAR FINISHER

< REMOVAL AND INSTALLATION >

REAR PILLAR FINISHER

Exploded View

INFOID:000000007769510

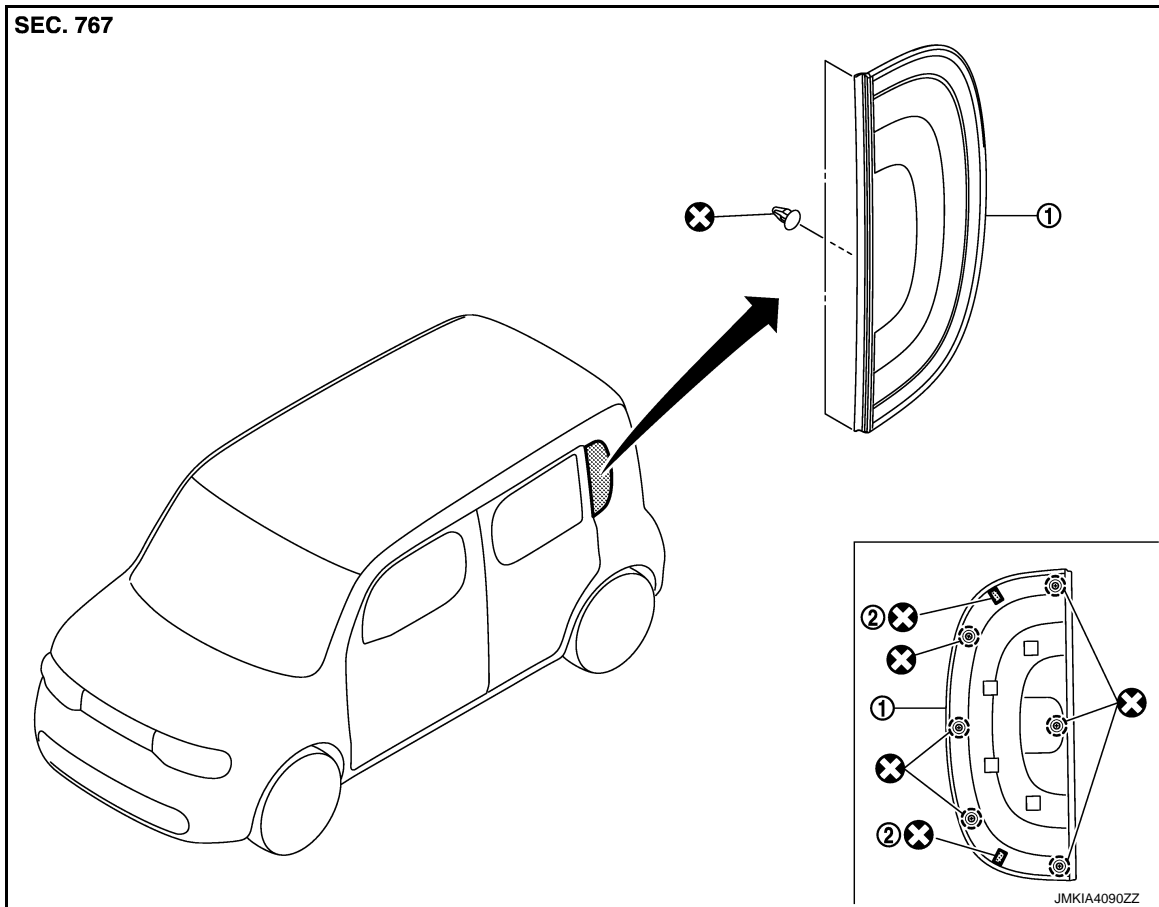

1. Rear pillar finisher

2. Double-faced adhesive tape
[1.2 mm (0.047 in)]

 : Clip

Refer to [GI-4. "Components"](#) for symbols in the figure.

Removal and Installation

INFOID:000000007769511

REMOVAL

Disengage rear pillar finisher fixing clips using remover tool (A), and then remove rear pillar finisher.

 : Clip

CAUTION:

Apply protective tape (B) to the body side to protect from damage.

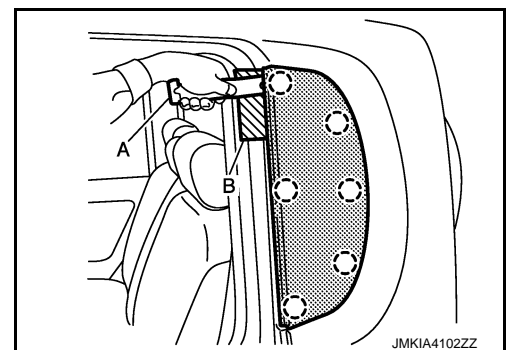

INSTALLATION

Note the following, and install in the reverse order of removal.

CAUTION:

• Always replace double-faced adhesive tape and dips with a new one, if rear pillar finisher is reused.

REAR PILLAR FINISHER

< REMOVAL AND INSTALLATION >

- When installing rear pillar finisher, check that clips are securely fitted in rear pillar panel holes, and then press them it.

A

B

C

D

E

F

G

H

I

J

EXT

L

M

N

O

P