

ENGINE LUBRICATION SYSTEM

CONTENTS

SYSTEM DESCRIPTION	2	Draining	8	
DESCRIPTION	2	Refilling	8	
Engine Lubrication System	2	OIL FILTER	10	
Engine Lubrication System Schematic	2	Removal and Installation	10	
PRECAUTION	3	Inspection	10	
PRECAUTIONS	3	REMOVAL AND INSTALLATION	11	
Liquid Gasket	3	OIL PUMP	11	
Precautions For Engine Service	4	Exploded View	11	
PREPARATION	5	Removal and Installation	12	
PREPARATION	5	Inspection	13	
Special Service Tools	5	SERVICE DATA AND SPECIFICATIONS		
Commercial Service Tools	5	(SDS)	14	
PERIODIC MAINTENANCE	7	SERVICE DATA AND SPECIFICATIONS		
ENGINE OIL	7	(SDS)	14	
Inspection	7	Periodical Maintenance Specification	14	
		Engine Oil Pressure	14	

DESCRIPTION

< SYSTEM DESCRIPTION >

SYSTEM DESCRIPTION

DESCRIPTION

Engine Lubrication System

INFOID:000000008450487

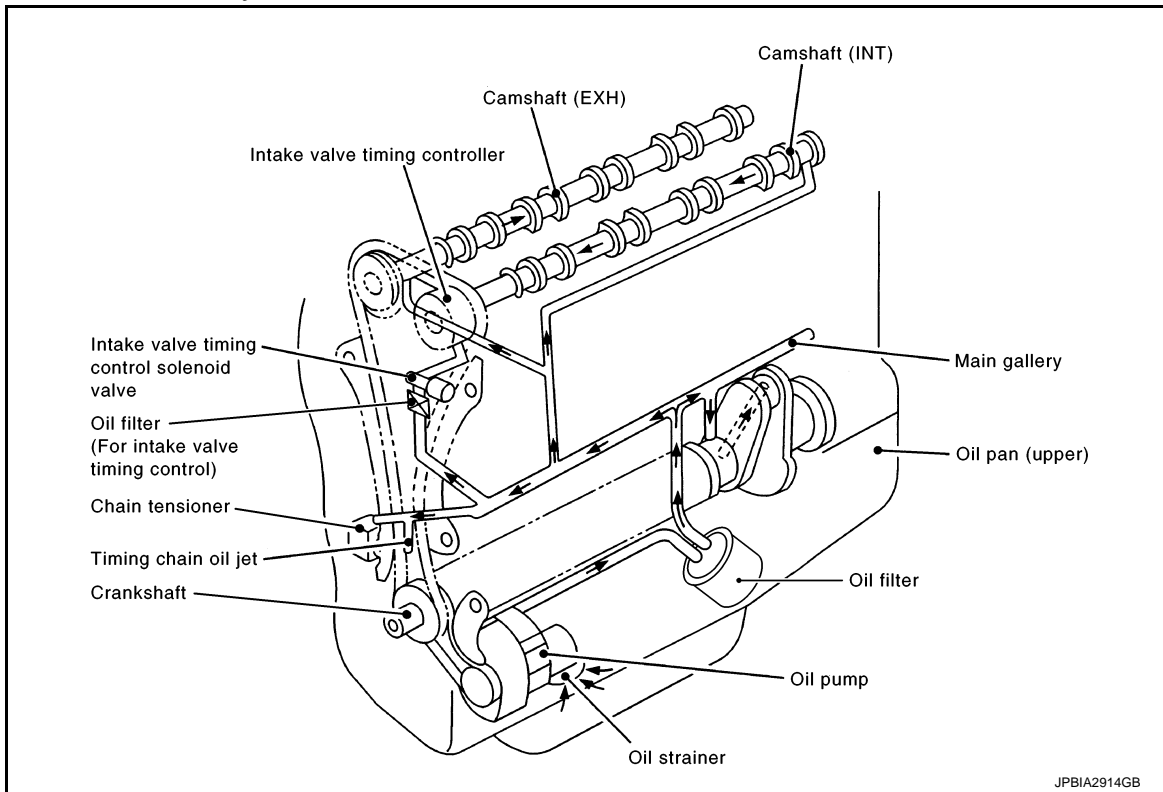

Engine Lubrication System Schematic

INFOID:000000008450488

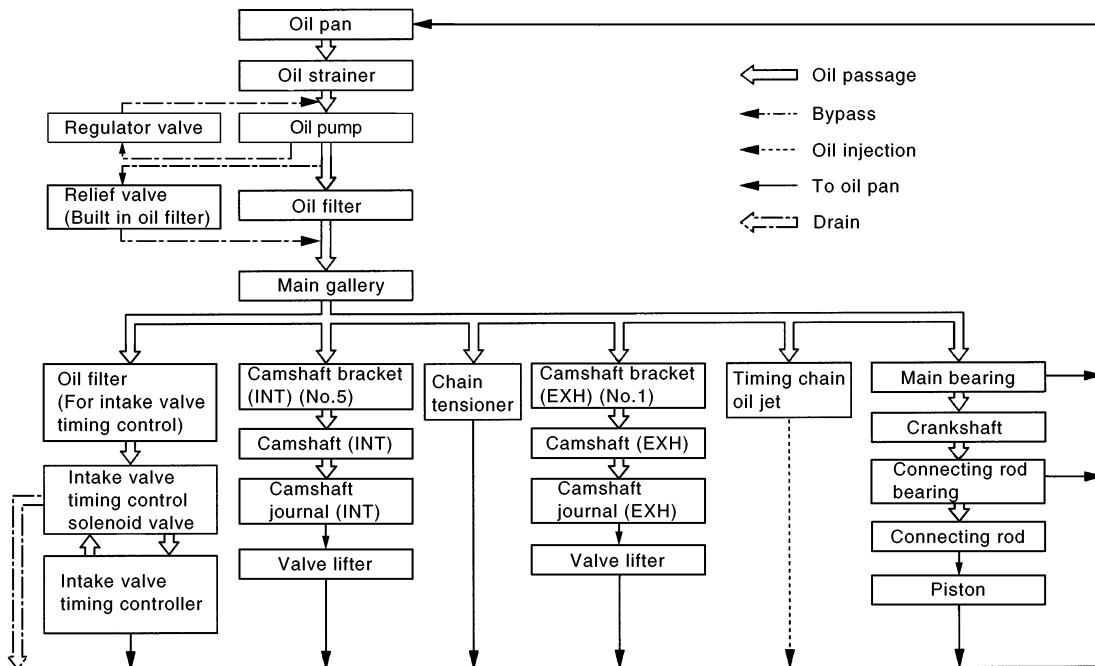

PRECAUTIONS

< PRECAUTION >

PRECAUTION

PRECAUTIONS

Liquid Gasket

INFOID:000000008450489

A

LU

REMOVAL OF LIQUID GASKET SEALING

- After removing mounting nuts and bolts, separate the mating surface using the seal cutter [SST: KV10111100 (J-37228)] (A) and remove old liquid gasket sealing.

CAUTION:

Be careful not to damage the mating surfaces.

- Tap the seal cutter [SST: KV10111100 (J-37228)] to insert it (B), and then slide it (C) by tapping on the side as shown in the figure.
- In areas where the seal cutter [SST: KV10111100 (J-37228)] is difficult to use, lightly tap the parts using a plastic hammer to remove it.

CAUTION:

If for some unavoidable reason tool such as a screwdriver is used, be careful not to damage the mating surfaces.

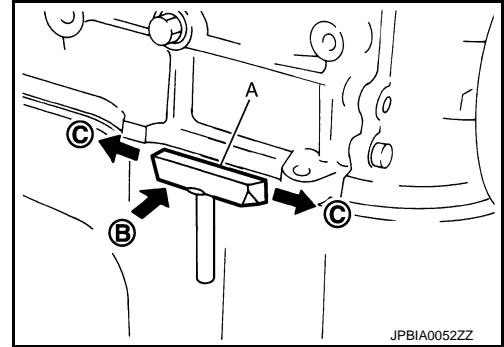

C

D

E

F

LIQUID GASKET APPLICATION PROCEDURE

1. Using a scraper (A), remove old liquid gasket adhering to the liquid gasket application surface and the mating surface.
 - Remove liquid gasket completely from the groove of the liquid gasket application surface, mounting bolts, and bolt holes.
2. Wipe the liquid gasket application surface and the mating surface with white gasoline (lighting and heating use) to remove adhering moisture, grease and foreign materials.

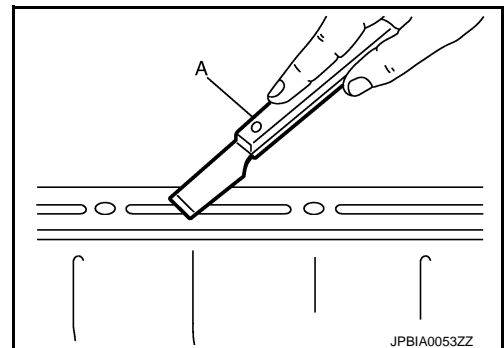

G

H

I

J

3. Attach liquid gasket tube to the tube presser (commercial service tool).

Use Genuine RTV Silicon Sealant or equivalent. Refer to [GI-22, "Recommended Chemical Products and Sealants"](#).

4. Apply liquid gasket without gaps to the specified location according to the specified dimensions.
 - If there is a groove for liquid gasket application, apply liquid gasket to the groove.

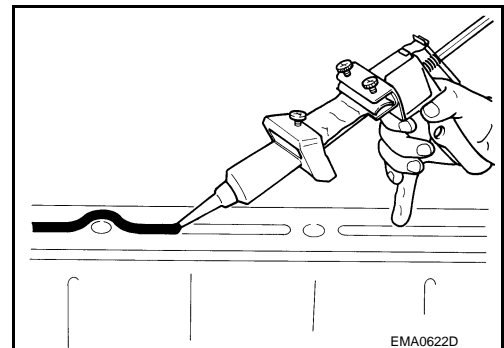

K

L

M

- As for bolt holes (B), normally apply liquid gasket inside the holes. Occasionally, it should be applied outside the holes. Check to read the text of this manual.

A : Groove

⇐ : Inside

- Within five minutes of liquid gasket application, install the mating component.
- If liquid gasket protrudes, wipe it off immediately.
- Do not retighten mounting bolts or nuts after the installation.
- After 30 minutes or more have passed from the installation, fill engine oil and engine coolant.

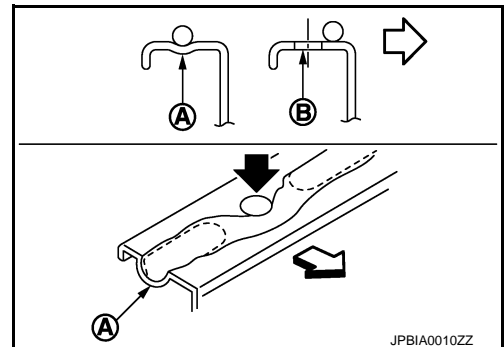

N

O

P

PRECAUTIONS

< PRECAUTION >

CAUTION:

If there are specific instructions in this manual, observe them.

Precautions For Engine Service

INFOID:000000008843682

DISCONNECTING FUEL PIPING

- Before starting work, check no fire or spark producing items are in the work area.
- Release fuel pressure before disconnecting and disassembly.
- After disconnecting pipes, plug openings to stop fuel leakage.

DRAINING ENGINE COOLANT

Drain engine coolant and engine oil when the engine is cooled.

INSPECTION, REPAIR AND REPLACEMENT

Before repairing or replacing, thoroughly inspect parts. Inspect new replacement parts in the same way, and replace if necessary.

REMOVAL AND DISASSEMBLY

- When instructed to use SST, use specified tools. Always be careful to work safely, avoid forceful or un instructed operations.
- Exercise maximum care to avoid damage to mating or sliding surfaces.
- Dowel pins are used for several parts alignment. When replacing and reassembling parts with dowel pins, check that dowel pins are installed in the original position.
- Must cover openings of engine system with a tape or equivalent, to seal out foreign materials.
- Mark and arrange disassembly parts in an organized way for easy troubleshooting and reassembly.
- When loosening nuts and bolts, as a basic rule, start with the one furthest outside, then the one diagonally opposite, and so on. If the order of loosening is specified, do exactly as specified. Power tools may be used in the step.

ASSEMBLY AND INSTALLATION

- Use torque wrench to tighten bolts or nuts to specification.
- When tightening nuts and bolts, as a basic rule, equally tighten in several different steps starting with the ones in center, then ones on inside and outside diagonally in this order. If the order of tightening is specified, do exactly as specified.
- Replace with new gasket, packing, oil seal or O-ring.
- Thoroughly wash, clean, and air-blow each part. Carefully check engine oil or engine coolant passages for any restriction and blockage.
- Avoid damaging sliding or mating surfaces. Completely remove foreign materials such as cloth lint or dust. Before assembly, oil sliding surfaces well.
- After disassembling , or exposing any internal engine parts, change engine oil and replace oil filter with a new one.
- Release air within route when refilling after draining engine coolant.
- After repairing, start the engine and increase engine speed to check engine coolant, fuel, engine oil, and exhaust gases for leakage.

PREPARATION

< PREPARATION >

PREPARATION

PREPARATION

Special Service Tools

INFOID:000000008450490

A

LU

The actual shapes of Kent-Moore tools may differ from those of special service tools illustrated here.

Tool number (Kent-Moore No.) Tool name	Description
KV10111100 (J-37228) Seat cutter	Removing oil pan (lower) etc.
ST25051001 (J-25695-1) Oil pressure gauge	Measuring oil pressure Maximum measuring range: 2,452 kPa (25 kg/cm², 356 psi)
ST25052000 (J-25695-2) Hose	Adapting oil pressure gauge to cylinder block
KV10115801 (J-38956) Oil filter wrench	Removing and installing oil filter a: 64.3 mm (2.531 in)

C

D

E

F

G

H

I

J

K

L

M

Commercial Service Tools

INFOID:000000008450491

N

O

P

PREPARATION

< PREPARATION >

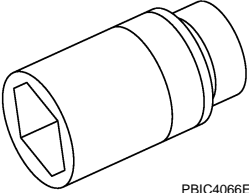
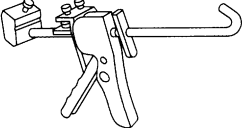
Tool name	Description
<p data-bbox="164 199 293 226">Deep socket</p>  <p data-bbox="829 415 898 436">PBIC4066E</p>	<p data-bbox="1010 199 1446 254">Removing and installing oil pressure switch 27 mm (1.06 in)</p>
<p data-bbox="164 451 293 478">Tube presser</p>  <p data-bbox="829 667 873 688">NT052</p>	<p data-bbox="1010 451 1344 478">Pressing the tube of liquid gasket</p>

ENGINE OIL

< PERIODIC MAINTENANCE >

PERIODIC MAINTENANCE

ENGINE OIL

Inspection

INFOID:000000008450492

A
LU

ENGINE OIL LEVEL

NOTE:

Before starting engine, put vehicle horizontally and check the engine oil level. If engine is already started, stop it and allow 10 minutes before checking.

1. Pull out oil level gauge and wipe it clean.
2. Insert oil level gauge and check that the engine oil level is within the range (A) shown in the figure.
3. If it is out of range, adjust it.

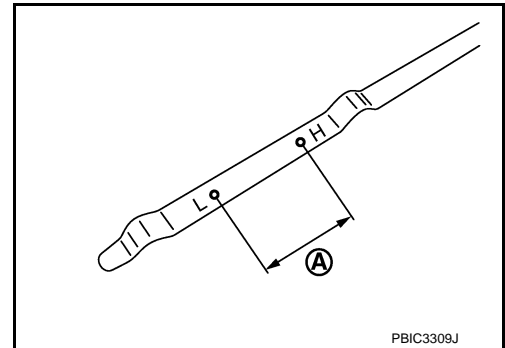

ENGINE OIL APPEARANCE

- Check engine oil for white turbidity or heavy contamination.
- If engine oil becomes turbid and white, it is highly probable that it is contaminated with engine coolant. Repair or replace damaged parts.

ENGINE OIL LEAKAGE

Check for engine oil leakage around the following area.

- Oil pan (upper and lower)
- Oil pan drain plug
- Oil pressure switch
- Oil filter
- Intake valve timing control solenoid valve
- Front cover
- Mating surface between cylinder head and camshaft bracket
- Mating surface between cylinder block and cylinder head
- Mating surface between cylinder head and rocker cover
- Crankshaft oil seals (front and rear)

OIL PRESSURE CHECK

WARNING:

- Be careful not to get burned, as engine oil may be hot.
- When checking engine oil pressure, shift position should be "Parking position", and apply parking brake securely.

1. Check engine oil level. Refer to [LU-7. "Inspection"](#).
2. Disconnect harness connector at oil pressure switch (1), and remove oil pressure switch using a deep socket (commercial service tool).

2 : Oil pan (lower)

↔ : Engine front

CAUTION:

Never drop or shock oil pressure switch.

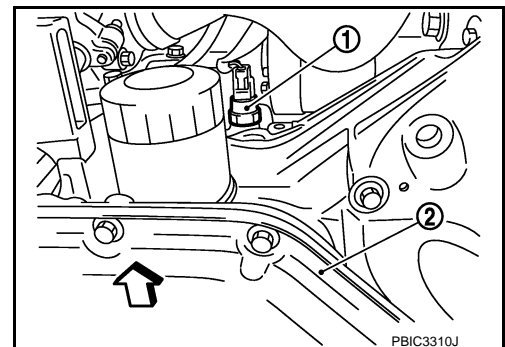

C
D
E
F
G
H
I
J
K
L
M
N
O
P

ENGINE OIL

< PERIODIC MAINTENANCE >

3. Install oil pressure gauge [SST: ST25051001 (J-25695-1)] (A) and hose [SST: ST25052000 (J-25695-2)] (B).

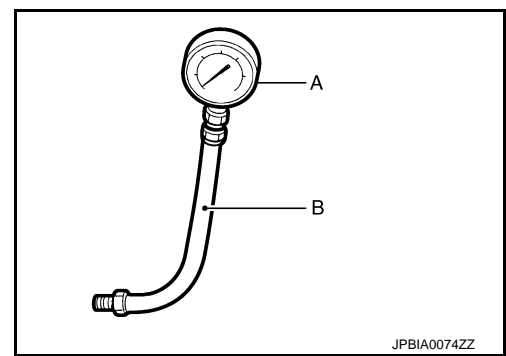

4. Start engine and warm it up to normal operating temperature.
5. Check oil pressure with engine running under no-load.
NOTE:
When engine oil temperature is low, engine oil pressure becomes high.

Engine oil pressure : Refer to [LU-14, "Engine Oil Pressure"](#).

If difference is extreme, check oil passage and oil pump for oil leakage.

6. After the inspections, install oil pressure switch as follows:
 - a. Remove old liquid gasket adhering to oil pressure switch and engine.
 - b. Apply liquid gasket and tighten oil pressure switch to specification.
Use Genuine RTV Silicon Sealant or equivalent. Refer to [GI-22, "Recommended Chemical Products and Sealants"](#).

Tightening torque : Refer to [EM-88, "Exploded View"](#).

- c. Check engine oil level. Refer to [LU-7, "Inspection"](#).
- d. After warming up engine, check that there is no leakage of engine oil with running engine.

Draining

INFOID:000000008450493

WARNING:

- Be careful not to get burned, as engine oil may be hot.
 - Prolonged and repeated contact with used engine oil may cause skin cancer. Try to avoid direct skin contact with used engine oil. If skin contact is made, wash thoroughly with soap or hand cleaner as soon as possible.
1. Warm up the engine, and check for engine oil leakage from engine components. Refer to [LU-7, "Inspection"](#).
 2. Stop the engine and wait for 10 minutes.
 3. Loosen oil filler cap.
 4. Remove drain plug and then drain engine oil.

Refilling

INFOID:000000008450494

1. Install drain plug with new drain plug washer. Refer to [EM-34, "Exploded View"](#).

CAUTION:

Be sure to clean drain plug and install with new drain plug washer.

Tightening torque : Refer to [EM-34, "Exploded View"](#).

2. Refill with new engine oil.
Engine oil specification and viscosity: Refer to [MA-10, "Fluids and Lubricants"](#).

Engine oil capacity : Refer to [LU-14, "Periodical Maintenance Specification"](#).

CAUTION:

ENGINE OIL

< PERIODIC MAINTENANCE >

- **The refill capacity depends on the engine oil temperature and drain time. Use these specifications for reference only.**
 - **Always use oil level gauge to determine the proper amount of engine oil in the engine.**
3. Warm up engine and check area around drain plug and oil filter for engine oil leakage.
 4. Stop engine and wait for 10 minutes.
 5. Check the engine oil level. Refer to [LU-7, "Inspection"](#).

A

LU

C

D

E

F

G

H

I

J

K

L

M

N

O

P

OIL FILTER

< PERIODIC MAINTENANCE >

OIL FILTER

Removal and Installation

INFOID:000000008450495

REMOVAL

1. Remove engine under cover. Refer to [EXT-22, "Exploded View"](#).
2. Using oil filter wrench [SST: KV10115801 (J-38956)] (A), remove oil filter.

⇐ : Vehicle front

CAUTION:

- Oil filter is provided with relief valve. Use genuine NISSAN oil filter or equivalent.
- Be careful not to get burned when engine and engine oil may be hot.
- When removing, prepare a shop cloth to absorb any engine oil leakage or spillage.
- Completely wipe off any engine oil that adheres to engine and vehicle.

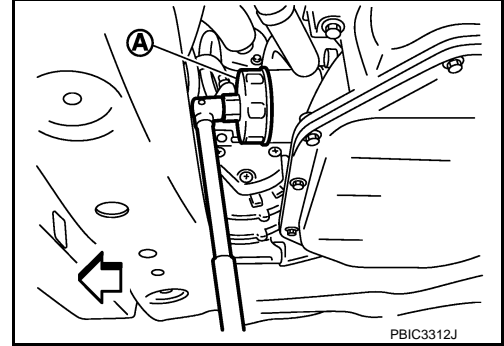

INSTALLATION

1. Remove foreign materials adhering to the oil filter installation surface.
2. Apply new engine oil to the oil seal contact surface of new oil filter.

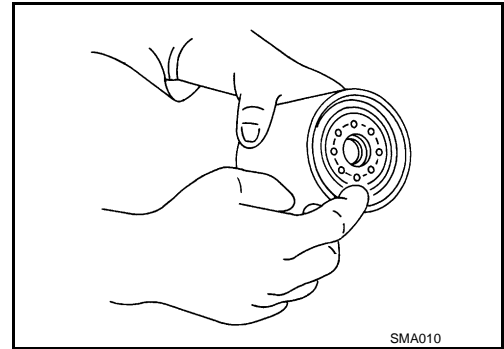

3. Screw oil filter manually until it touches the installation surface, then tighten it by 2/3 turn (A). Or tighten to specification.

Oil filter:

: 17.7 N·m (1.8 kg-m, 13 ft-lb)

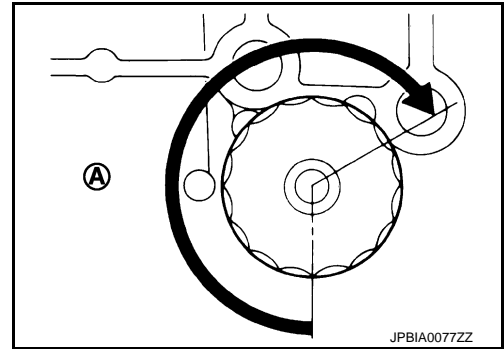

Inspection

INFOID:000000008450496

INSPECTION AFTER INSTALLATION

1. Check the engine oil level. Refer to [LU-7, "Inspection"](#).
2. Start the engine, and check that there is no leakage of engine oil.
3. Stop the engine and wait for 10 minutes.
4. Check the engine oil level, and adjust the level. Refer to [LU-7, "Inspection"](#).

OIL PUMP

< REMOVAL AND INSTALLATION >

REMOVAL AND INSTALLATION

OIL PUMP

Exploded View

INFOID:000000008450497

A

LU

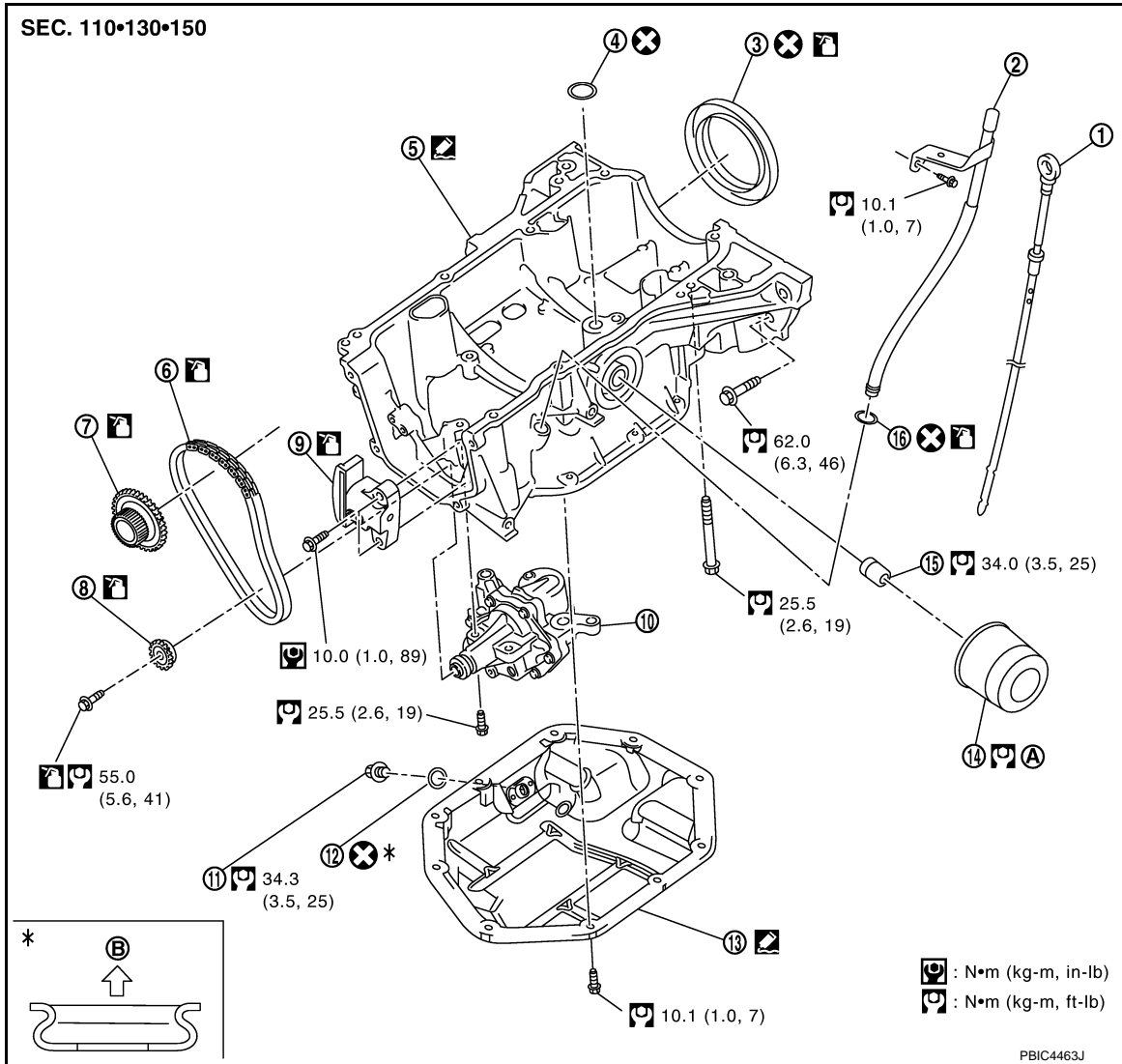

C

D

E

F

G

H

I

J

K

L

M

N

O

P

- | | | |
|------------------------|--------------------------|-----------------------------|
| 1. Oil level gauge | 2. Oil level gauge guide | 3. Rear oil seal |
| 4. O-ring | 5. Oil pan (upper) | 6. Oil pump drive chain |
| 7. Crankshaft sprocket | 8. Oil pump sprocket | 9. Oil pump chain tensioner |
| 10. Oil pump | 11. Drain plug | 12. Drain plug washer |
| 13. Oil pan (lower) | 14. Oil filter | 15. Connector bolt |
| 16. O-ring | | |
- A. Comply with the assembly procedure when tightening. Refer to [LU-10](#)
 B. Oil pan side

: Always replace after every disassembly.

: Should be lubricated with oil.

: Sealing point

OIL PUMP

< REMOVAL AND INSTALLATION >

Removal and Installation

INFOID:00000008450498

REMOVAL

1. Remove oil pan (lower). Refer to [EM-34, "Exploded View"](#).
2. Remove front cover, and other related parts. Refer to [EM-44, "Exploded View"](#).
3. Remove oil pump sprocket with the following procedure:
 - Add matching mark if necessary for easier installation.
- a. Press stopper tab (A) in the direction shown in the figure to push the oil pump chain tensioner slack guide (B) toward oil pump chain tensioner (1).
 - The oil pump chain tensioner slack guide is released by pressing the stopper tab. As the result, the oil pump chain tensioner slack guide can be moved.
- b. Insert a stopper pin (D) into tensioner body hole (C) to secure the oil pump chain tensioner slack guide.

NOTE:
Use a hard metal pin with the diameter of approximately 1.2 mm (0.047 in) as a stopper pin.
- c. Remove oil pump chain tensioner.
 - When the holes on lever and tensioner body cannot be aligned, align these holes by slightly moving the oil pump chain tensioner slack guide.

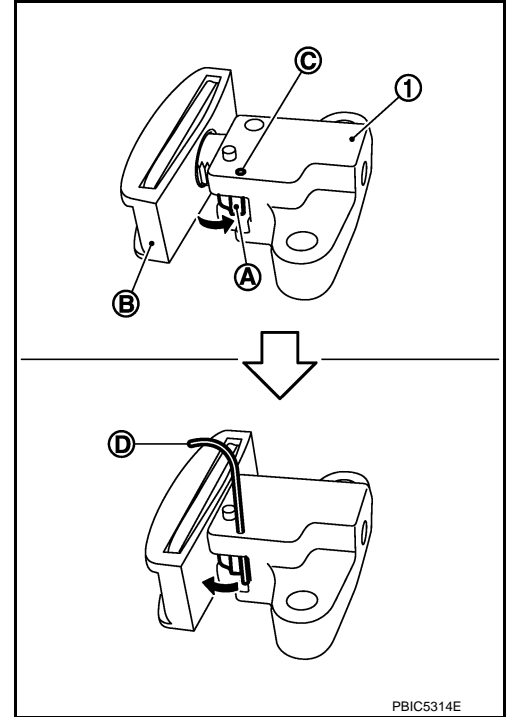

- d. Hold the WAF part of oil pump shaft [WAF: 10 mm (0.39 in)] (A), and then loosen the oil pump sprocket bolt and remove it.

- 1 : Oil pan (upper)
- 2 : Oil pump
- ⇐ : Engine front

CAUTION:

- **Secure the oil pump shaft with the WAF part.**
- **Never loosen the oil pump sprocket bolt by tightening the oil pump drive chain.**

- e. Remove oil pump sprocket.

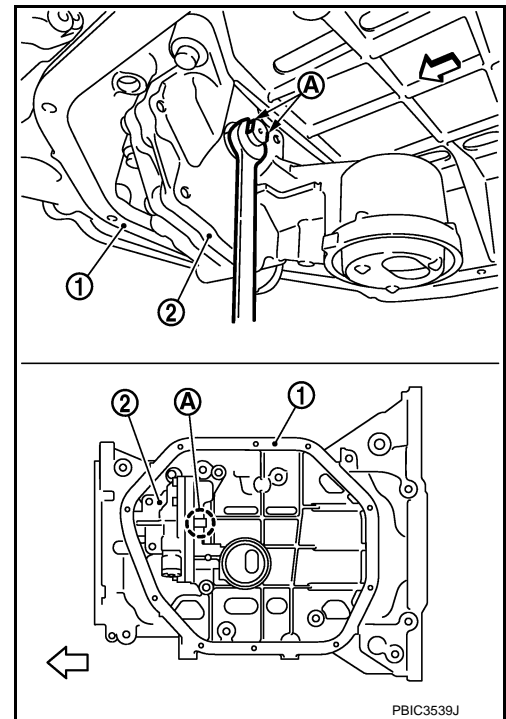

4. Remove oil pump.

OIL PUMP

< REMOVAL AND INSTALLATION >

- Loosen bolts in reverse order as shown in the figure.

- 1 : Oil pump
- 2 : Oil pan (upper)
- ⇐ : Engine front

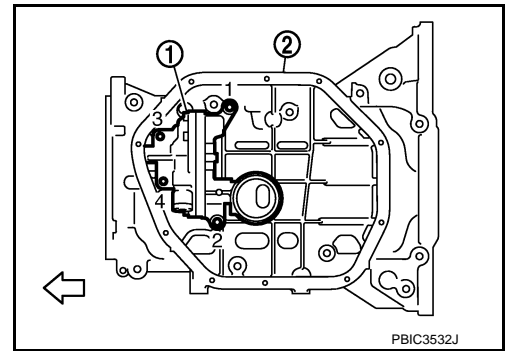

INSTALLATION

Note the following, and install in the reverse order of removal.

Oil Pump

- Tighten bolts in numerical order as shown in the figure.

- 1 : Oil pump
- 2 : Oil pan (upper)
- ⇐ : Engine front

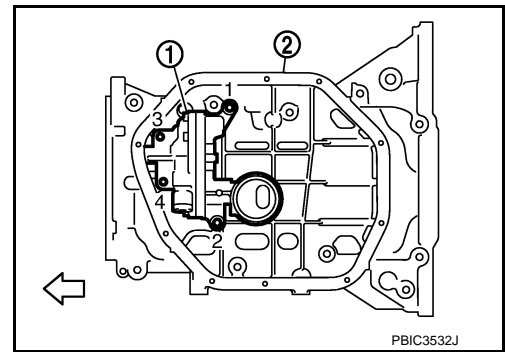

Inspection

INFOID:000000008450499

INSPECTION AFTER INSTALLATION

1. Check the engine oil level. Refer to [LU-7. "Inspection"](#).
2. Start the engine, and check that there is no leakage of engine oil.
3. Stop the engine and wait for 10 minutes.
4. Check the engine oil level, and adjust the level. Refer to [LU-7. "Inspection"](#).

SERVICE DATA AND SPECIFICATIONS (SDS)

< SERVICE DATA AND SPECIFICATIONS (SDS)

SERVICE DATA AND SPECIFICATIONS (SDS)

SERVICE DATA AND SPECIFICATIONS (SDS)

Periodical Maintenance Specification

INFOID:000000008450500

ENGINE OIL CAPACITY (APPROXIMATE)

Unit: ℓ (US qt, Imp qt)

Drain and refill	With oil filter change	4.1 (4-3/8, 3-5/8)
	Without oil filter change	3.8 (4, 3-3/8)
Dry engine (Overhaul)		4.9 (5-1/8, 4-3/8)

Engine Oil Pressure

INFOID:000000008450501

Unit: kPa (kg/cm², psi)

Engine speed	Approximate discharge pressure*
Idle speed	60 (0.61, 9)
2,000 rpm	200 (2.0, 29)

*: Engine oil temperature at 80°C (176°F)