

SECTION BR
BRAKE SYSTEM

A
B
C
D
E

CONTENTS

SYMPTOM DIAGNOSIS	3	DISC ROTOR	14	BR
NOISE, VIBRATION AND HARSHNESS (NVH) TROUBLESHOOTING	3	DISC ROTOR : Inspection and Adjustment	14	
NVH Troubleshooting Chart	3	REAR DRUM BRAKE	16	G
PRECAUTION	4	BRAKE LINING	16	
PRECAUTIONS	4	BRAKE LINING : Inspection	16	H
Caution for Supplemental Restraint System (SRS) "AIR BAG" and "SEAT BELT PRE-TENSIONER"	4	BRAKE DRUM	16	
Caution for Procedure without Cowl Top Cover.....	4	BRAKE DRUM : Inspection	16	I
Caution for Brake System	4	REMOVAL AND INSTALLATION	17	
Precautions for Removing of Battery Terminal	5	BRAKE PEDAL	17	J
PREPARATION	6	Exploded View	17	
PREPARATION	6	Removal and Installation	18	K
Commercial Service Tool	6	Inspection and Adjustment	18	
PERIODIC MAINTENANCE	7	BRAKE PIPING	20	L
BRAKE PEDAL	7	FRONT	20	
Inspection and Adjustment	7	FRONT : Exploded View	20	M
BRAKE FLUID	10	FRONT : Hydraulic Piping	21	
Inspection	10	FRONT : Removal and Installation	21	N
Draining	10	FRONT : Inspection	22	
Refilling	10	REAR	22	O
Bleeding Brake System	11	REAR : Exploded View	22	
BRAKE MASTER CYLINDER	12	REAR : Hydraulic Piping	23	P
Inspection	12	REAR : Removal and Installation	23	
BRAKE BOOSTER	13	REAR : Inspection	24	
Inspection	13	BRAKE MASTER CYLINDER	25	
FRONT DISC BRAKE	14	Exploded View	25	
BRAKE PAD	14	Removal and Installation	25	
BRAKE PAD : Inspection and Adjustment	14	Disassembly and Assembly	26	
		Inspection	27	
		BRAKE BOOSTER	28	
		Exploded View	28	
		Removal and installation	28	
		Inspection and Adjustment	29	

VACUUM LINES	31	REAR DRUM BRAKE	39
Exploded View	31	Exploded View	39
Removal and Installation	31	Removal and Installation	39
Inspection	31	Disassembly and Assembly	41
FRONT DISC BRAKE	33	Inspection and Adjustment	41
BRAKE PAD	33	SERVICE DATA AND SPECIFICATIONS	
BRAKE PAD : Exploded View	33	(SDS)	43
BRAKE PAD : Removal and Installation	33	SERVICE DATA AND SPECIFICATIONS	
BRAKE PAD : Inspection	34	(SDS)	43
BRAKE CALIPER ASSEMBLY	34	General Specifications	43
BRAKE CALIPER ASSEMBLY : Exploded View ...	34	Brake Pedal	43
BRAKE CALIPER ASSEMBLY : Removal and In-		Brake Booster	43
stallation	35	Front Disc Brake	43
BRAKE CALIPER ASSEMBLY : Disassembly and		Rear Drum Brake	43
Assembly	36		
BRAKE CALIPER ASSEMBLY : Inspection	38		

PRECAUTIONS

< PRECAUTION >

PRECAUTION

PRECAUTIONS

Precaution for Supplemental Restraint System (SRS) "AIR BAG" and "SEAT BELT PRE-TENSIONER"

INFOID:000000009949196

The Supplemental Restraint System such as "AIR BAG" and "SEAT BELT PRE-TENSIONER", used along with a front seat belt, helps to reduce the risk or severity of injury to the driver and front passenger for certain types of collision. This system includes seat belt switch inputs and dual stage front air bag modules. The SRS system uses the seat belt switches to determine the front air bag deployment, and may only deploy one front air bag, depending on the severity of a collision and whether the front occupants are belted or unbelted. Information necessary to service the system safely is included in the "SRS AIR BAG" and "SEAT BELT" of this Service Manual.

WARNING:

Always observe the following items for preventing accidental activation.

- To avoid rendering the SRS inoperative, which could increase the risk of personal injury or death in the event of a collision that would result in air bag inflation, all maintenance must be performed by an authorized NISSAN/INFINITI dealer.
- Improper maintenance, including incorrect removal and installation of the SRS, can lead to personal injury caused by unintentional activation of the system. For removal of Spiral Cable and Air Bag Module, see "SRS AIR BAG".
- Never use electrical test equipment on any circuit related to the SRS unless instructed to in this Service Manual. SRS wiring harnesses can be identified by yellow and/or orange harnesses or harness connectors.

PRECAUTIONS WHEN USING POWER TOOLS (AIR OR ELECTRIC) AND HAMMERS

WARNING:

Always observe the following items for preventing accidental activation.

- When working near the Air Bag Diagnosis Sensor Unit or other Air Bag System sensors with the ignition ON or engine running, never use air or electric power tools or strike near the sensor(s) with a hammer. Heavy vibration could activate the sensor(s) and deploy the air bag(s), possibly causing serious injury.
- When using air or electric power tools or hammers, always switch the ignition OFF, disconnect the battery, and wait at least 3 minutes before performing any service.

Precaution for Procedure without Cowl Top Cover

INFOID:000000009949197

When performing the procedure after removing cowl top cover, cover the lower end of windshield with urethane, etc to prevent damage to windshield.

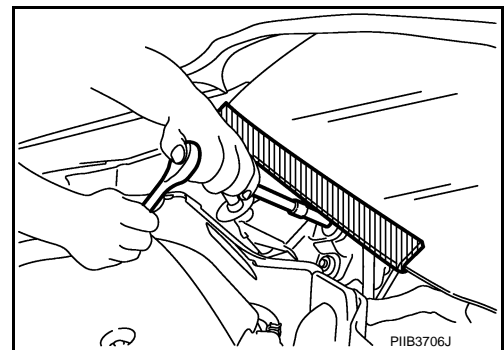

Precaution for Brake System

INFOID:000000009949198

WARNING:

Since dust covering the front and rear brakes has an affect on human body, the dust must be removed with a dust collector. Never splatter the dust with an air blow gun.

- Brake fluid use refer to [MA-10, "Fluids and Lubricants"](#).
- Never reuse drained brake fluid.
- Never spill or splash brake fluid on painted surfaces. Brake fluid may seriously damage paint. Wipe it off immediately and wash with water if it gets on a painted surface.

PRECAUTIONS

< PRECAUTION >

- After pressing the brake pedal more deeply or harder than normal driving, such as air bleeding, check each item of brake pedal. Adjust brake pedal if it is outside the standard value.
- Always clean with new brake fluid when cleaning the master cylinder, brake caliper and other components.
- Never use mineral oils such as gasoline or light oil to clean. They may damage rubber parts and cause improper operation.
- Always loosen the brake tube flare nut with a flare nut wrench.
- Tighten the brake tube flare nut to the specified torque with a crow-foot (A) and torque wrench (B).
- Always confirm the specified tightening torque when installing the brake pipes.
- Brake system is an important safety part. If a brake fluid leak is detected, always disassemble the affected part. If a malfunction is detected, replace part with a new one.
- Turn the ignition switch OFF and disconnect the ABS actuator and electric unit (control unit) connector or the battery negative terminal before performing the work.
- Check that no brake fluid leakage is present after replacing the parts.
- Burnish the brake contact surfaces after refinishing or replacing rotors, after replacing pads, or if a soft pedal occurs at very low mileage.
 - Front brake pad: Refer to [BR-14, "BRAKE PAD : Inspection and Adjustment"](#).
 - Front disc rotor: Refer to [BR-14, "DISC ROTOR : Inspection and Adjustment"](#).

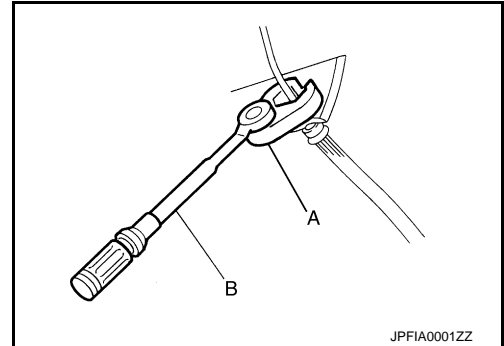

Precautions for Removing of Battery Terminal

INFOID:0000000010078174

- When removing the 12V battery terminal, turn OFF the ignition switch and wait at least 30 seconds.

NOTE:

ECU may be active for several tens of seconds after the ignition switch is turned OFF. If the battery terminal is removed before ECU stops, then a DTC detection error or ECU data corruption may occur.

- For vehicles with the 2-batteries, be sure to connect the main battery and the sub battery before turning ON the ignition switch.

NOTE:

If the ignition switch is turned ON with any one of the terminals of main battery and sub battery disconnected, then DTC may be detected.

- After installing the 12V battery, always check "Self Diagnosis Result" of all ECUs and erase DTC.

NOTE:

The removal of 12V battery may cause a DTC detection error.

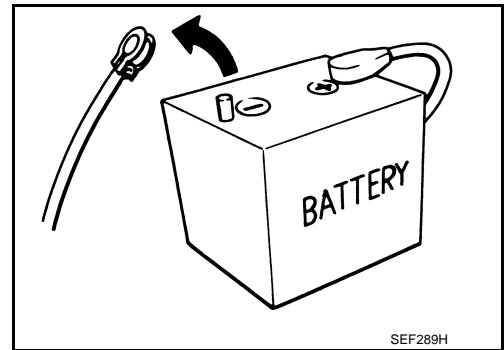

PREPARATION



< PREPARATION >

PREPARATION

PREPARATION

Commercial Service Tool

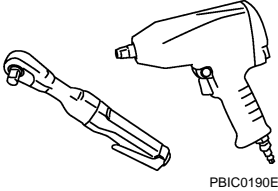
INFOID:000000009949199

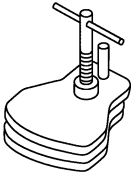
Tool name	Description
<p>Power tool</p>  <p>PBIC0190E</p>	<p>Loosening bolts and nuts</p>
<p>Handy vacuum pump</p>  <p>ZZC1313D</p>	<ul style="list-style-type: none">• Air tight• Inspection of check valve
<p>Brake caliper wrench</p>  <p>NNFIA0040ZZ</p>	<p>Return the piston</p>

BRAKE PEDAL

< PERIODIC MAINTENANCE >

PERIODIC MAINTENANCE

BRAKE PEDAL

Inspection and Adjustment

INFOID:000000009949200

INSPECTION

Brake Pedal Height

Check the height (H₁) between the dash lower panel (1) and the brake pedal upper surface.

H₁ : Refer to [BR-43, "Brake Pedal"](#).

CAUTION:

Remove the floor trim.

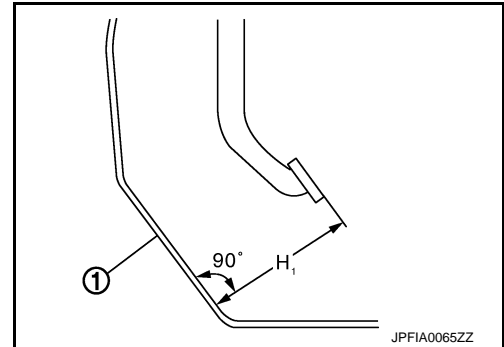

Stop Lamp Switch

Check the clearance (C) among the brake pedal lever (1) and the stop lamp switch (2) threaded end.

C : Refer to [BR-43, "Brake Pedal"](#).

CAUTION:

The stop lamp must turn off when the brake pedal is released.

NOTE:

Pull the brake pedal pad to make the clearance between the stop lamp switch threaded end and the brake pedal lever.

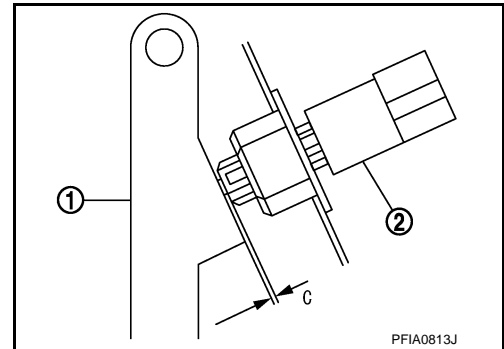

ASCD Brake Switch (With ASCD)

Check the clearance (C) among the brake pedal bracket (1) and the ASCD brake switch (2) threaded end.

C : Refer to [BR-43, "Brake Pedal"](#).

NOTE:

Pull the brake pedal pad to make the clearance between the ASCD brake switch threaded end and the brake pedal bracket.

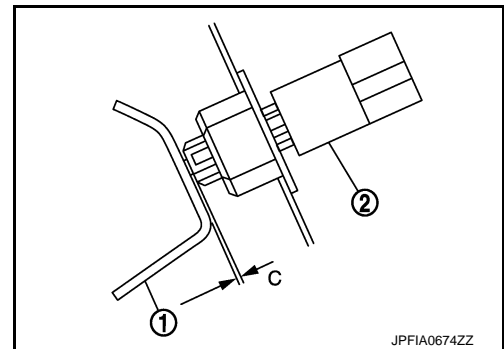

Brake Pedal Play

Press the brake pedal. Check the brake pedal play (A) (stroke until fluid pressure occurs).

A : Refer to [BR-43, "Brake Pedal"](#).

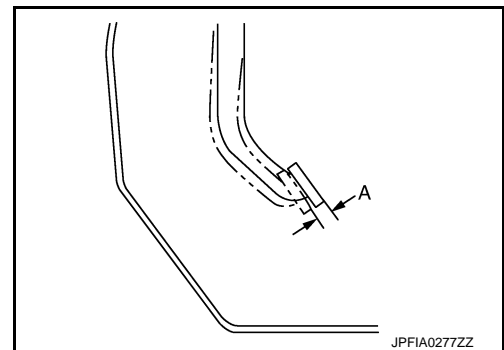

Depressed Brake Pedal Height

A
B
C
D
E
BR
G
H
I
J
K
L
M
N
O
P

BRAKE PEDAL

< PERIODIC MAINTENANCE >

Check the height between the dash lower panel (1) and the brake pedal upper surface (H_2) when depressing the brake pedal at 490 N (50 kg, 110 lb) while turning engine ON.

H_2 : Refer to [BR-43, "Brake Pedal"](#).

CAUTION:

Remove the floor trim.

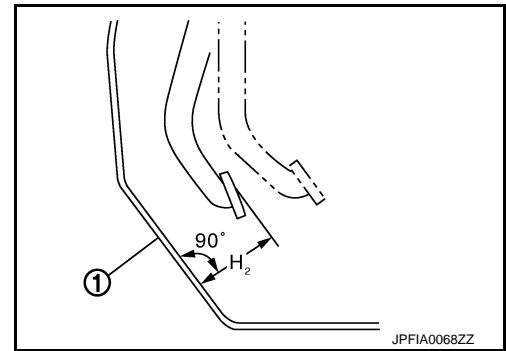

ADJUSTMENT

Brake Pedal Height

1. Remove instrument lower panel LH. Refer to [IP-13, "Exploded View"](#).
2. Disconnect the harness connector from ASCD brake switch and stop lamp switch.
3. Loosen the ASCD brake switch and stop lamp switch 45° counterclockwise.
4. Adjust the brake pedal height with the following procedure.
 - a. Loosen the input rod lock nut (1).

CAUTION:

The threaded end of the input rod (2) must project to the inner side (L) of the clevis (3).

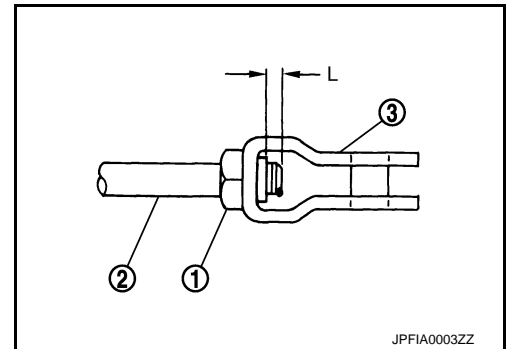

- b. Rotate the input rod, adjust the brake pedal to the specified height (H_1).

H_1 : Refer to [BR-43, "Brake Pedal"](#).

- c. Tighten the lock nut. Refer to [BR-28, "Exploded View"](#).
5. Check the brake pedal play.

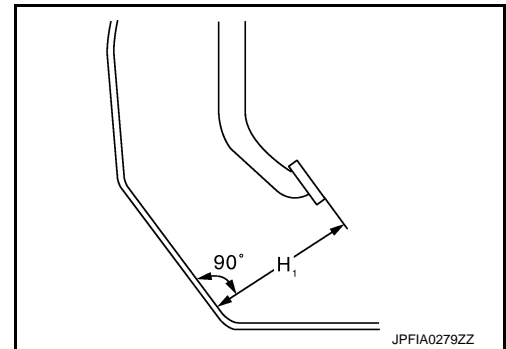

Brake Pedal Play

NOTE:

The clearance between the stop lamp switch threaded end and the brake pedal lever and the clearance between the ASCD brake switch threaded end and the brake pedal bracket (with ASCD) are adjusted by adjusting play of the brake pedal.

1. Remove instrument lower panel LH. Refer to [IP-13, "Exploded View"](#).
2. Disconnect the harness connector from ASCD brake switch (with ASCD) and stop lamp switch.
3. Loosen the ASCD brake switch (with ASCD) and stop lamp switch 45° counterclockwise.

BRAKE PEDAL

< PERIODIC MAINTENANCE >

4. Press-fit the stop lamp switch (2) until the stop lamp switch hits the brake pedal lever 45° clockwise while pulling the brake pedal pad slightly.

CAUTION:

- The clearance (C) between the brake pedal lever and stop lamp switch threaded end must be the specified value.

C : Refer to [BR-43, "Brake Pedal"](#).

- The stop lamp must be turned off when the brake pedal is released.

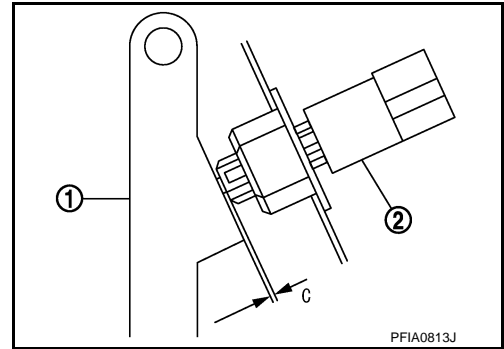

5. Press-fit the ASCD brake switch (2) until the ASCD brake switch hits the brake pedal bracket 45° clockwise while pulling the brake pedal pad slightly. (With ASCD)

CAUTION:

- The clearance (C) between the brake pedal lever and stop lamp switch threaded end must be the specified value.

C : Refer to [BR-43, "Brake Pedal"](#).

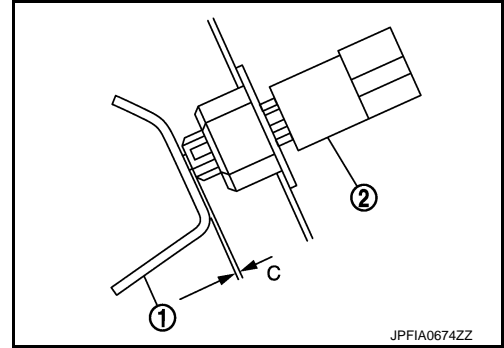

A
B
C
D
E
BR
G
H
I
J
K
L
M
N
O
P

BRAKE FLUID

< PERIODIC MAINTENANCE >

BRAKE FLUID

Inspection

INFOID:000000009949201

BRAKE FLUID LEVEL

- Check that the fluid level in the reservoir tank is within the specified range (MAX – MIN lines).
- Visually check for any brake fluid leakage around the reservoir tank.
- Check the brake system for any leakage if the fluid level is extremely low (lower than MIN).
- Check the brake system for fluid leakage if the warning lamp remains illuminated even after the parking brake is released.
- Check the reservoir tank for the mixing of foreign matter (e.g. dust) and oils other than brake fluid.

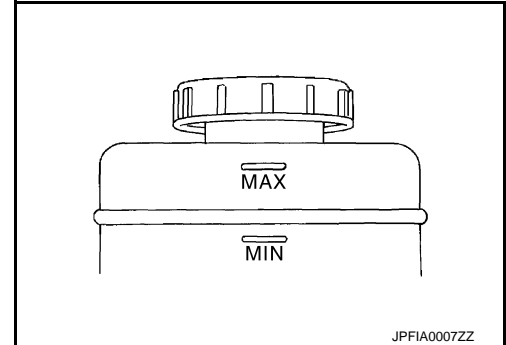

BRAKE LINE

1. Check brake line (tubes and hoses) for cracks, deterioration or other damage. Replace any damaged parts.
2. Depress the brake pedal with a force of 785 N (80 kg, 176 lb) and hold down the pedal for approximately 5 seconds with the engine running. Check for any fluid leakage.

CAUTION:

Retighten the applicable connection to the specified torque and repair any abnormal (damaged, worn or deformed) part if any brake fluid leakage is present.

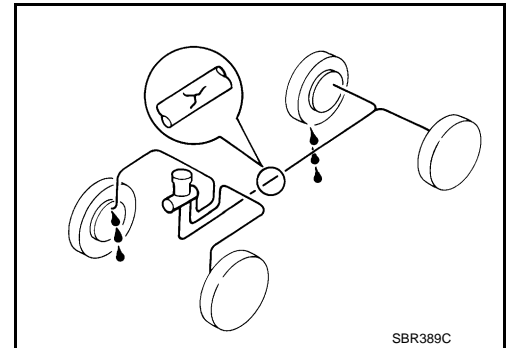

Draining

INFOID:000000009949202

CAUTION:

- Never spill or splash brake fluid on painted surfaces. Brake fluid may seriously damage paint. Wipe it off immediately and wash with water if it gets on a painted surface.
- Turn the ignition switch OFF and disconnect the ABS actuator and electric unit (control unit) connector or the battery negative terminal before performing work.

1. Connect a vinyl tube to the bleed valve.
2. Depress the brake pedal and loosen the bleeder valve to gradually discharge brake fluid.

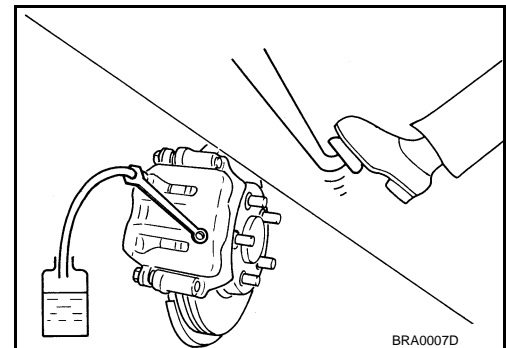

Refilling

INFOID:000000009949203

CAUTION:

- Turn the ignition switch OFF and disconnect the ABS actuator and electric unit (control unit) connector or the battery negative terminal before performing work.
- Never allow foreign matter (e.g. dust) and oils other than brake fluid to enter the reservoir tank.

BRAKE FLUID

< PERIODIC MAINTENANCE >

1. Check that there is no foreign material in the reservoir tank, and refill with new brake fluid.

CAUTION:

Never reuse drained brake fluid.

2. Loosen the bleeder valve, slowly depress the brake pedal to the full stroke, and then release the pedal. Repeat this operation at intervals of 2 or 3 seconds until all brake fluid is discharged. Then close the bleeder valve with the brake pedal depressed. Repeat the same work on each wheel.
3. Perform the air bleeding. Refer to [BR-11. "Bleeding Brake System"](#).

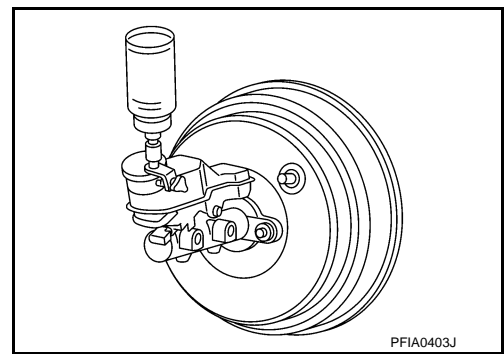

Bleeding Brake System

INFOID:000000009949204

CAUTION:

- Turn the ignition switch OFF and disconnect the ABS actuator and electric unit (control unit) connector or the battery negative terminal before performing the work.
- Monitor the fluid level in the reservoir tank while performing the air bleeding
- Always use new brake fluid for refilling. Never reuse the drained brake fluid.
- Never allow foreign matter (e.g. dust) and oils other than brake fluid to enter the reservoir tank.

1. Connect a vinyl tube to the bleeder valve of the rear right brake.
2. Fully depress the brake pedal 4 to 5 times.
3. Loosen the bleeder valve and bleed air with the brake pedal depressed, and then quickly tighten the bleeder valve.
4. Repeat steps 2 and 3 until all of the air is out of the brake line.
5. Tighten the bleeder valve to the specified torque.
 - Front disc brake: Refer to [BR-34. "BRAKE CALIPER ASSEMBLY : Exploded View"](#).
 - Rear drum brake: Refer to [BR-39. "Exploded View"](#).
6. Perform steps 1 to 5 for the rear right brake → front left brake → rear left brake → and front right brake in order.
7. Check that the fluid level in the reservoir tank is within the specified range after air bleeding. Refer to [BR-10. "Inspection"](#).
8. Check each item of brake pedal. Adjust it if the measurement value is not the standard. Refer to [BR-7. "Inspection and Adjustment"](#).

BRAKE MASTER CYLINDER

< PERIODIC MAINTENANCE >

BRAKE MASTER CYLINDER

Inspection

INFOID:000000009949205

FLUID LEAK

Check for brake fluid leakage from the master cylinder mounting face, reservoir tank mounting face and brake tube connections.

BRAKE BOOSTER

< PERIODIC MAINTENANCE >

BRAKE BOOSTER

Inspection

INFOID:000000009949206

OPERATION

Depress the brake pedal several times at 5-second intervals with the engine stopped. Start the engine with the brake pedal fully depressed. Check that the clearance between brake pedal and dash lower panel decreases.

AIR TIGHT

1. Run the engine for 1 minute to apply vacuum to the brake booster, and stop the engine. Then depress the brake pedal several times at 5-second intervals until the accumulated vacuum is released to atmospheric pressure. Check that the clearance between brake pedal and dash lower panel gradually increases each time the brake pedal is depressed when performing this operation.
2. Depress the brake pedal with the engine running. Then stop the engine while holding down the brake pedal. Check that the brake pedal stroke does not change after holding down the brake pedal for 30 seconds or more.

A
B
C
D
E
G
H
I
J
K
L
M
N
O
P

BR

FRONT DISC BRAKE

< PERIODIC MAINTENANCE >

FRONT DISC BRAKE

BRAKE PAD

BRAKE PAD : Inspection and Adjustment

INFOID:000000009949207

INSPECTION

Check brake pad wear thickness from an inspection hole on cylinder body. Check using a scale if necessary.

Wear thickness : Refer to [BR-43, "Front Disc Brake"](#).

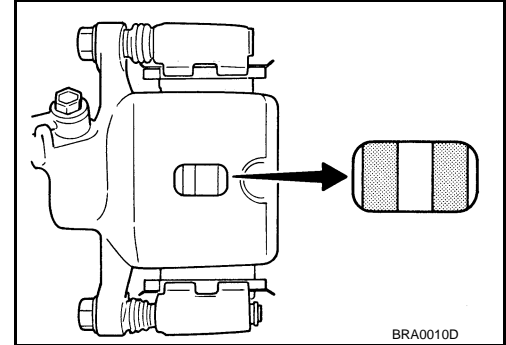

ADJUSTMENT

Burnish contact surfaces between pads according to the following procedure after refinishing or replacing pads, or if a soft pedal occurs at very low mileage.

CAUTION:

- **Be careful of vehicle speed because the brake does not operate firmly/securely until pads and disc rotor are securely fitted.**
- **Only perform this procedure under safe road and traffic conditions. Use extreme caution.**

1. Drive vehicle on straight, flat road.
2. Depress brake pedal with the power to stop vehicle within 3 to 5 seconds until the vehicle stops.
3. Drive without depressing brake for a few minutes to cool the brake.
4. Repeat steps 1 to 3 until pad and disc rotor are securely fitted.

DISC ROTOR

DISC ROTOR : Inspection and Adjustment

INFOID:000000009949208

INSPECTION

Appearance

Check surface of disc rotor for uneven wear, cracks, and serious damage. Replace it if necessary. Refer to [BR-35, "BRAKE CALIPER ASSEMBLY : Removal and Installation"](#).

Runout

1. Fix the disc rotor to the wheel hub and bearing assembly with wheel nuts (2 points at least).
2. Check the wheel bearing axial end play before the inspection. Refer to [FAX-7, "Inspection"](#).
3. Inspect the runout with a dial indicator to measure at 10 mm (0.39 in) inside the disc edge.

Runout : Refer to [BR-43, "Front Disc Brake"](#).

4. Find the installation position that has a minimum runout by shifting the disc rotor-to-wheel hub and bearing assembly installation position by one hole at a time if the runout exceeds the limit value.
5. Refinish the disc rotor if the runout is outside the limit even after performing the above operation. [When refinishing, use the Pro-Cut PEM On-Car brake Lathe (Tool No. 38-PFM90.5) or equivalent.]

CAUTION:

- **Check in advance that the thickness of the disc rotor is wear thickness + 0.3 mm (0.012 in) or more.**

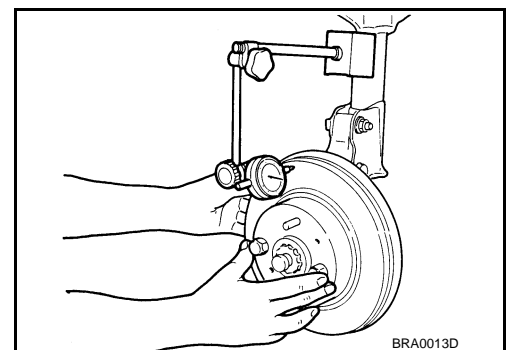

FRONT DISC BRAKE

< PERIODIC MAINTENANCE >

- If the thickness is less than wear thickness + 0.3 mm (0.012 in), replace the disc rotor.

Wear thickness : Refer to [BR-43, "Front Disc Brake"](#).

Thickness

Check the thickness of the disc rotor using a micrometer. Replace the disc rotor if the thickness is below the wear limit. Refer to [BR-35, "BRAKE CALIPER ASSEMBLY : Removal and Installation"](#).

Wear thickness : Refer to [BR-43, "Front Disc Brake"](#).

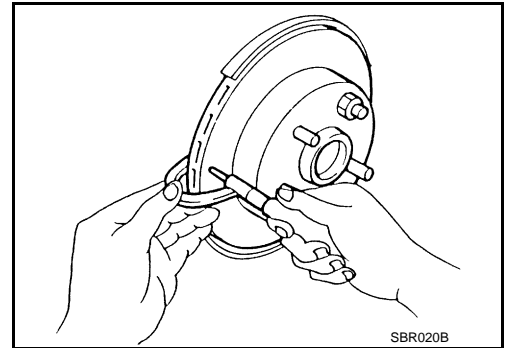

ADJUSTMENT

Burnish contact surfaces between disc rotors and pads according to the following procedure after refinishing or replacing disc rotor, or if a soft pedal occurs at very low mileage.

CAUTION:

- **Be careful of vehicle speed because the brake does not operate firmly/securely until pad and disc rotor are securely fitted.**
 - **Only perform this procedure under safe road and traffic conditions. Use extreme caution.**
1. Drive vehicle on straight, flat road.
 2. Depress brake pedal with the power to stop vehicle within 3 to 5 seconds until the vehicle stops.
 3. Drive without depressing brake for a few minutes to cool the brake.
 4. Repeat steps 1 to 3 until pad and disc rotor are securely fitted.

REAR DRUM BRAKE

< PERIODIC MAINTENANCE >

REAR DRUM BRAKE BRAKE LINING

BRAKE LINING : Inspection

INFOID:000000009949209

INSPECTION OF BRAKE LINING

1. Remove plug from back plate. Refer to [BR-39, "Exploded View"](#).
2. Check brake lining wear thickness (A) from an inspection hole on back plate. Check using a scale if necessary.

A : Refer to [BR-43, "Rear Drum Brake"](#).

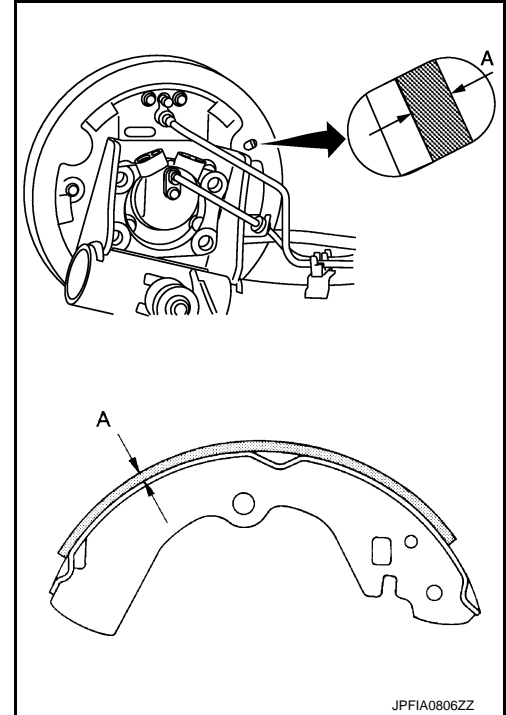

BRAKE DRUM

BRAKE DRUM : Inspection

INFOID:000000009949210

APPEARANCE

Check surface of brake drum for uneven wear, cracks and serious damage. Replace it if necessary. Refer to [BR-39, "Exploded View"](#).

INSPECTION OF BRAKE DRUM INNER DIAMETER

Check inner diameter (B) of the brake drum.

B : Refer to [BR-43, "Rear Drum Brake"](#).

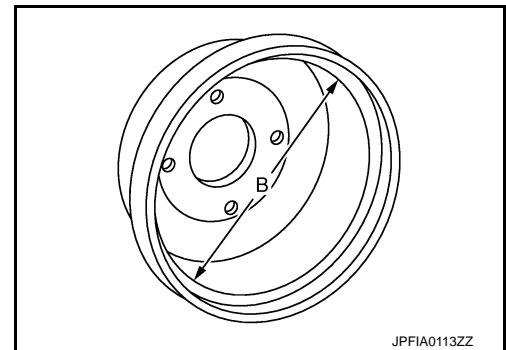

BRAKE PEDAL

< REMOVAL AND INSTALLATION >

REMOVAL AND INSTALLATION

BRAKE PEDAL

Exploded View

INFOID:000000009949211

WITH ASCD

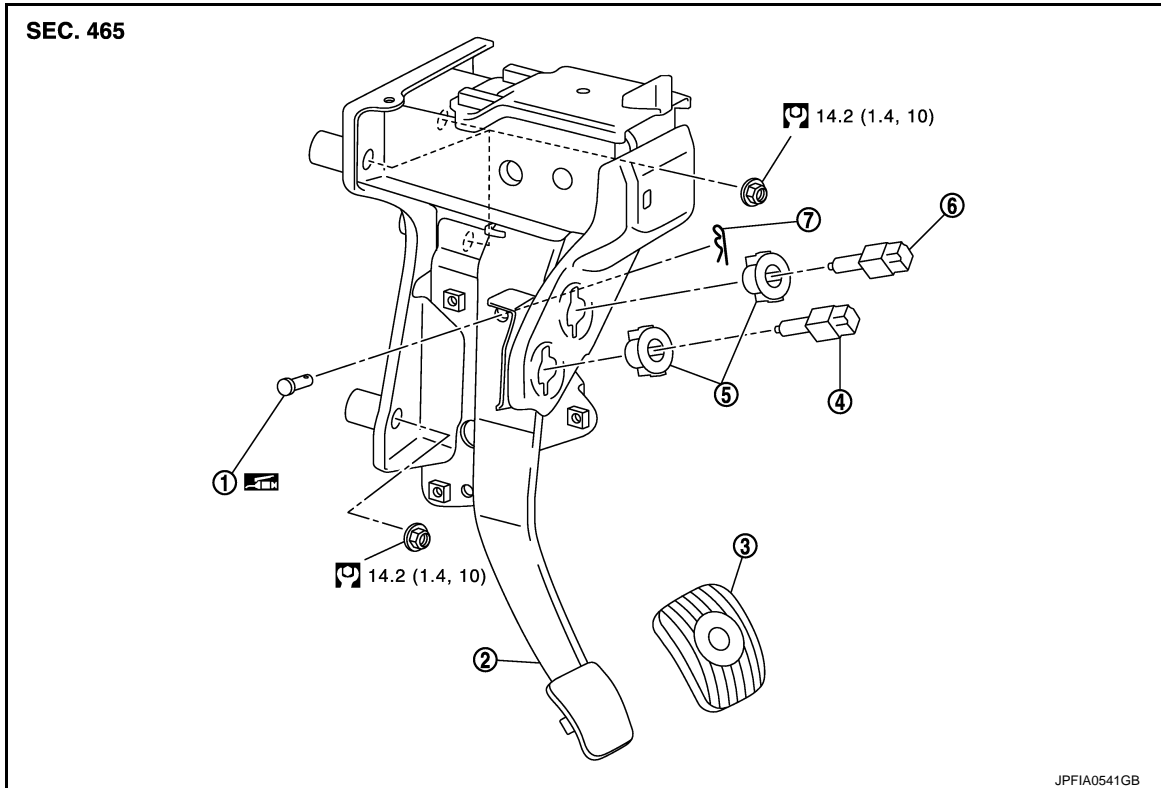

- | | | |
|----------------------|-------------------------|---------------------|
| 1. Clevis pin | 2. Brake pedal assembly | 3. Brake pedal pad |
| 4. ASCD brake switch | 5. Clip | 6. Stop lamp switch |
| 7. Snap pin | | |

: Apply multi-purpose grease.

Refer to [GI-4, "Components"](#) for symbols not described on the above.

WITHOUT ASCD

A
B
C
D
E
BR
G
H
I
J
K
L
M
N
O
P

BRAKE PEDAL

< REMOVAL AND INSTALLATION >

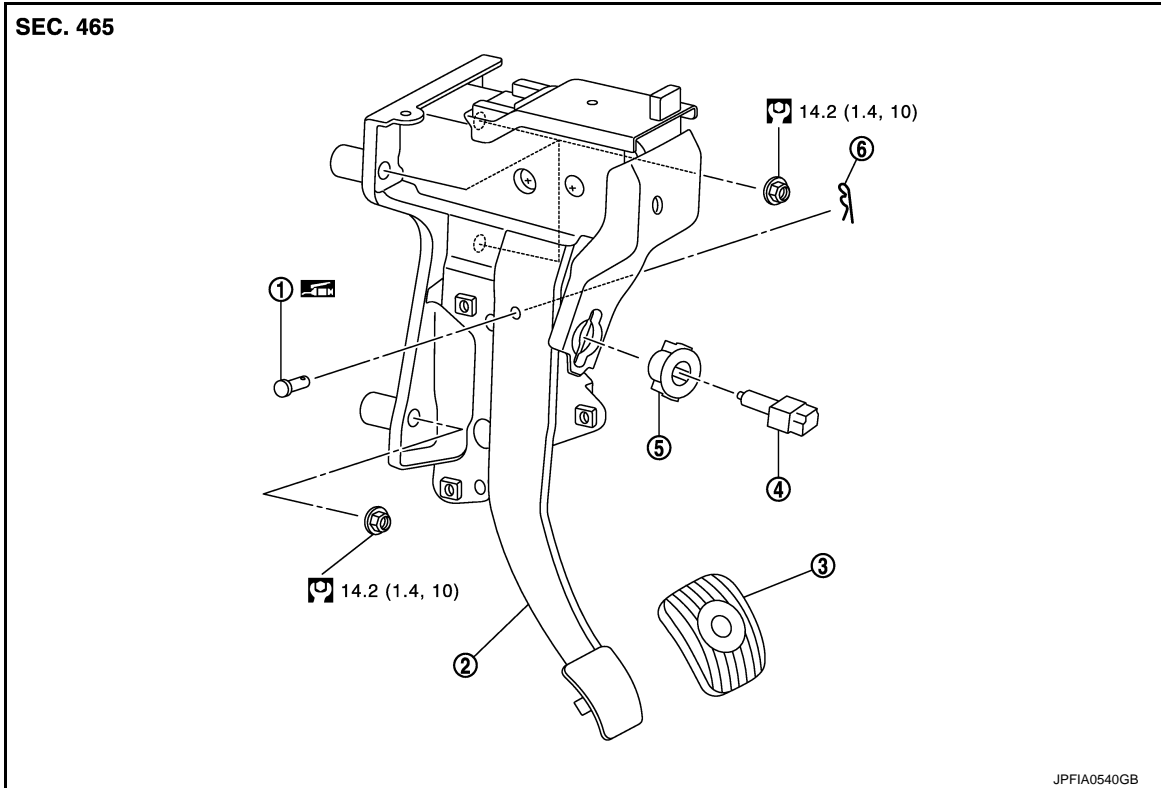

- | | | |
|---------------------|-------------------------|--------------------|
| 1. Clevis pin | 2. Brake pedal assembly | 3. Brake pedal pad |
| 4. Stop lamp switch | 5. Clip | 6. Snap pin |

: Apply multi-purpose grease.

Refer to [GI-4. "Components"](#) for symbols not described on the above.

Removal and Installation

INFOID:000000009949212

REMOVAL

1. Remove instrument lower panel LH. Refer to [IP-13. "Exploded View"](#).
2. Remove knee protector. Refer to [ST-11. "Removal and Installation"](#).
3. Disconnect the stop lamp switch and ASCD brake switch (with ASCD) harness connectors.
4. Disconnect the accelerator pedal harness connector and clip.
5. Remove snap pin and clevis pin from clevis.
6. Remove the brake pedal assembly.
7. Remove accelerator pedal from brake pedal assembly. Refer to [ACC-3. "Exploded View"](#).

INSTALLATION

Note the following, and install in the reverse order of removal.

- Apply the multi-purpose grease to the clevis pin and the mating faces. (Not necessary if grease has been already applied)

NOTE:

The clevis pin may be inserted in either direction.

Inspection and Adjustment

INFOID:000000009949213

INSPECTION AFTER REMOVAL

- Check for the following items and replace the brake pedal assembly if necessary.

BRAKE PEDAL

< REMOVAL AND INSTALLATION >

- Check the brake pedal upper rivet (made by aluminum) (A) for deformation.
- Check the brake pedal for bend, damage, and cracks on the welded parts.
- Check the lapping length (X) of sub-bracket (B) and slide plate (C).

Standard

X : 6.5 mm (0.256 in) or more

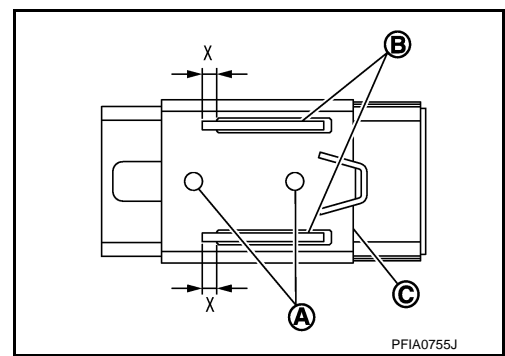

- Check clevis pin and plastic stopper (A) for damage and deformation. If any is found, replace clevis pin.

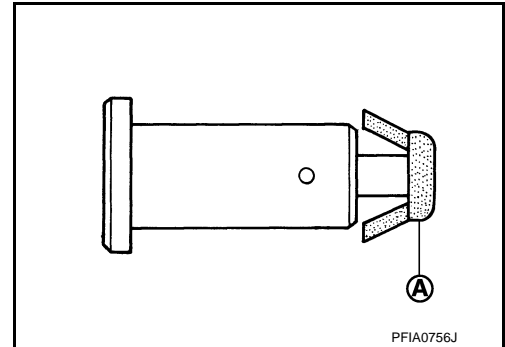

ADJUSTMENT AFTER INSTALLATION

- Adjust each item of brake pedal after installing the brake pedal assembly to the vehicle. Refer to [BR-7. "Inspection and Adjustment"](#).
- Perform the release position learning of the accelerator pedal. Refer to [EC-19. "ACCELERATOR PEDAL RELEASED POSITION LEARNING : Special Repair Requirement"](#).

A
B
C
D
E
BR
G
H
I
J
K
L
M
N
O
P

BRAKE PIPING

< REMOVAL AND INSTALLATION >

BRAKE PIPING

FRONT

FRONT : Exploded View

INFOID:000000009949214

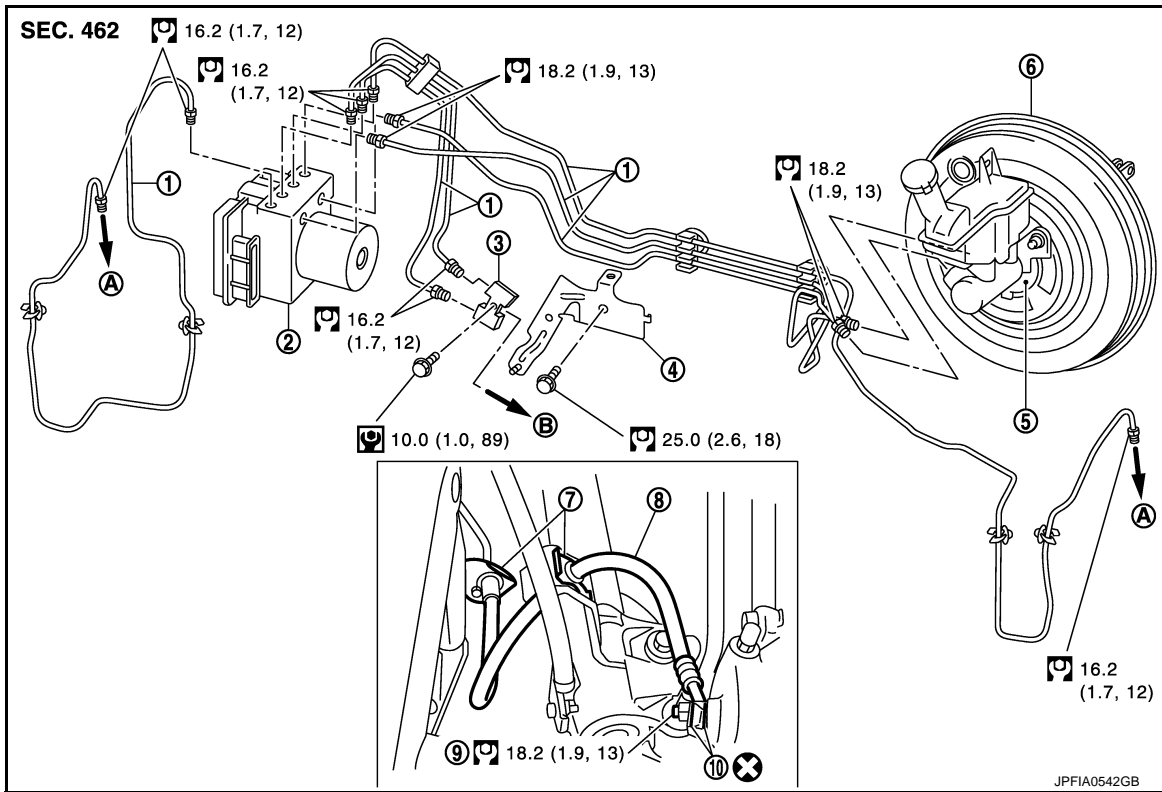

- | | | |
|------------------------|--|------------------|
| 1. Brake tube | 2. ABS actuator and electric unit (control unit) | 3. Connector |
| 4. Connector bracket | 5. Master cylinder | 6. Brake booster |
| 7. Lock plate | 8. Brake hose | 9. Union bolt |
| 10. Copper washer | | |
| A. To front brake hose | B. To rear brake tube | |

Refer to [GI-4. "Components"](#) for symbols in the figure.

BRAKE PIPING

< REMOVAL AND INSTALLATION >

FRONT : Hydraulic Piping

INFOID:000000009949215

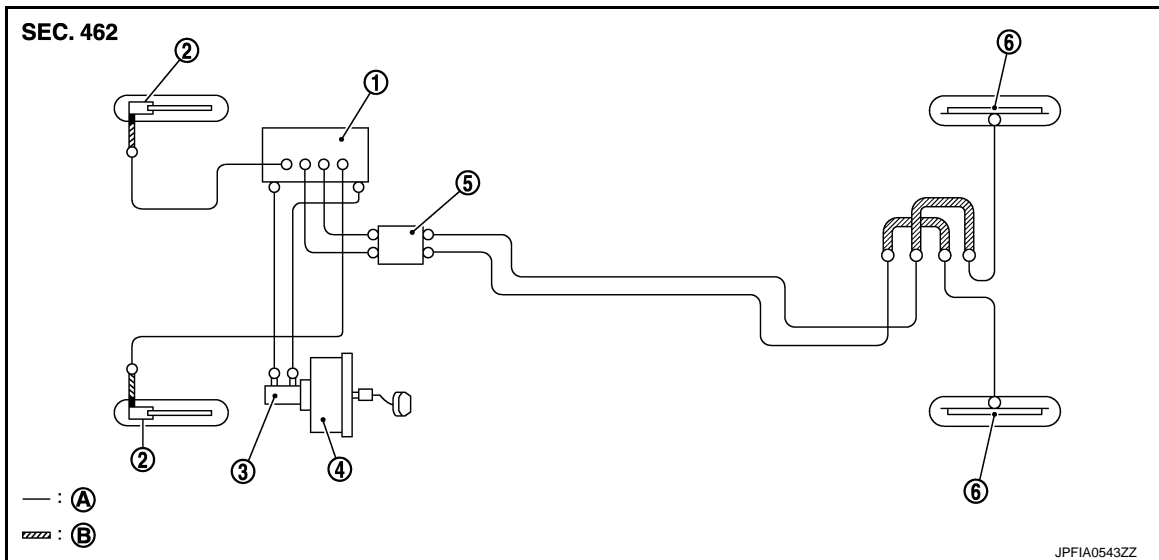

- | | | |
|--|---------------------|--------------------|
| 1. ABS actuator and electric unit (control unit) | 2. Front disc brake | 3. Master cylinder |
| 4. Brake booster | 5. Connector | 6. Rear drum brake |
| A. Brake tube | B. Brake hose | |

- : Flare nut
- : Union bolt

FRONT : Removal and Installation

INFOID:000000009949216

REMOVAL

CAUTION:

Never spill or splash brake fluid on painted surfaces. Brake fluid may seriously damage paint. Wipe it off immediately and wash with water if it gets on a painted surface.

1. Remove tires with power tool.
2. Drain brake fluid. Refer to [BR-10, "Draining"](#).
3. Loosen the flare nut with a flare nut wrench and separate the brake tube from the hose, and remove the brake tube.

CAUTION:

- **Never scratch the flare nut and the brake tube.**
- **Never bend sharply, twist or strongly pull out the brake hoses and tubes.**
- **Cover open end of brake tubes and hoses when disconnecting to prevent entrance of dirt.**

4. Remove the union bolt and copper washers, and remove the brake hose from the brake caliper assembly.
5. Remove the lock plate and remove the brake hose.

INSTALLATION

CAUTION:

- **Never spill or splash brake fluid on painted surfaces. Brake fluid may seriously damage paint. Wipe it off immediately and wash with water if it gets on a painted surface.**
- **Never allow foreign matter (e.g. dust) and oils other than brake fluid to enter the reservoir tank.**

1. Assemble the union bolt and the copper washer to the brake hose.

CAUTION:

Never reuse the copper washer.

BRAKE PIPING

< REMOVAL AND INSTALLATION >

- Align the brake hose pin to the projection (A) of the brake caliper assembly and tighten the union bolt (1) to the specified torque.
- Install the brake tube to the brake hose, temporarily tighten the flare nut by hand until it does not rotate further, and fix the brake hose to the bracket with the lock plate.

CAUTION:

Check that all brake hoses and brake tubes are not twisted and bent.

- Tighten the flare nut to the specified torque with a flare nut crow-foot and a torque wrench.

CAUTION:

Never scratch the flare nut and the brake tube.

- Refill with new brake fluid and perform the air bleeding. Refer to [BR-11. "Bleeding Brake System"](#).

CAUTION:

Never reuse drained brake fluid.

- Install tires.

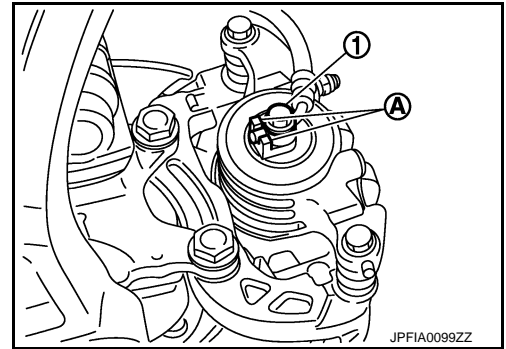

FRONT : Inspection

INFOID:000000009949217

INSPECTION AFTER INSTALLATION

- Check the brake hoses and tubes for the following: no scratches; no twist and deformation; no interference with other components when steering the steering wheel; no looseness at connections.
- Depress the brake pedal with a force of 785 N (80 kg, 176 lb) and hold down the pedal for approximately 5 seconds with the engine running. Check for any fluid leakage.

CAUTION:

Retighten the applicable connection to the specified torque and repair any abnormal (damaged, worn or deformed) part if any brake fluid leakage is present.

REAR

REAR : Exploded View

INFOID:000000009949218

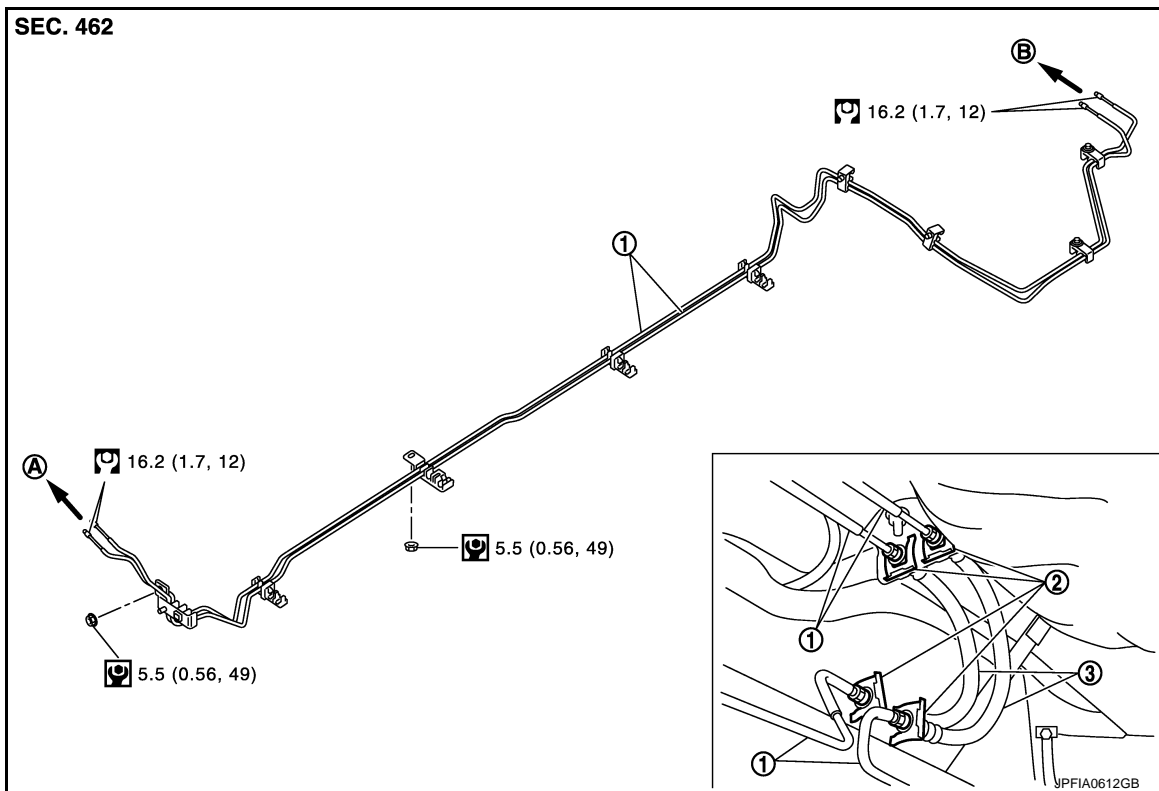

BRAKE PIPING

< REMOVAL AND INSTALLATION >

- | | | |
|-----------------|-----------------------|---------------|
| 1. Brake tube | 2. Lock plate | 3. Brake hose |
| A. To connector | B. To rear brake hose | |

Refer to [GI-4, "Components"](#) for symbols in the figure.

REAR : Hydraulic Piping

INFOID:000000009949219

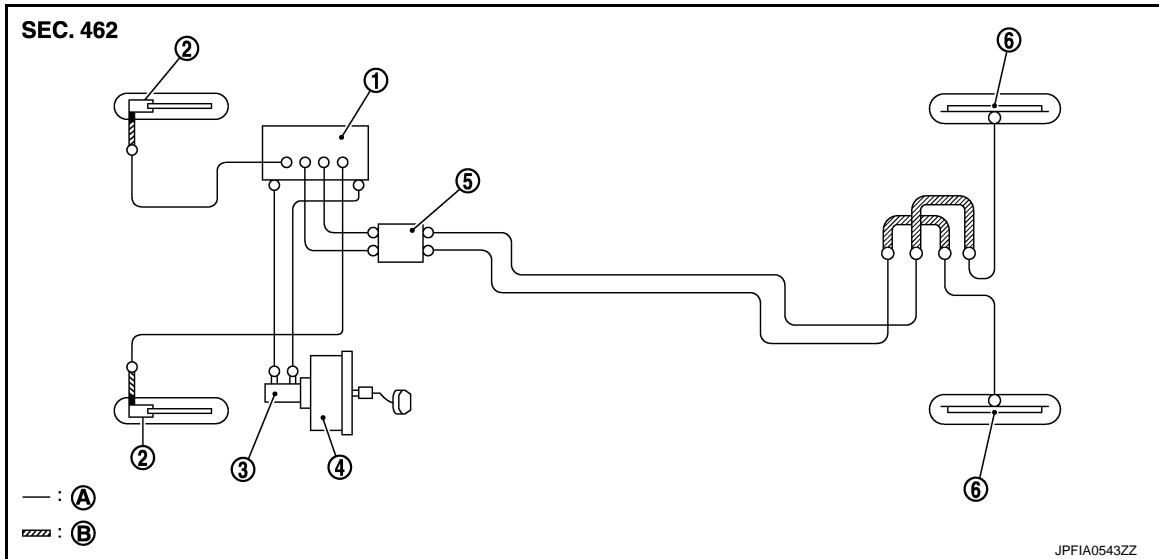

- | | | |
|--|---------------------|--------------------|
| 1. ABS actuator and electric unit (control unit) | 2. Front disc brake | 3. Master cylinder |
| 4. Brake booster | 5. Connector | 6. Rear drum brake |
| A. Brake tube | B. Brake hose | |

- : Flare nut
■ : Union bolt

REAR : Removal and Installation

INFOID:000000009949220

REMOVAL

CAUTION:

Never spill or splash brake fluid on painted surfaces. Brake fluid may seriously damage paint. Wipe it off immediately and wash with water if it gets on a painted surface.

1. Remove tires with power tool.
2. Drain brake fluid. Refer to [BR-10, "Draining"](#).
3. Loosen the flare nut with a flare nut wrench and separate the brake tube from the brake hose.

CAUTION:

- Never scratch the flare nut and the brake tube.
- Never sharply bend, twist or strongly pull the brake hoses and tubes.
- Cover the open end of brake tubes and hoses when disconnecting to prevent entrance of dirt.

4. Remove the lock plate and remove the brake hose from the vehicle.

INSTALLATION

CAUTION:

- Never spill or splash brake fluid on painted surfaces. Brake fluid may seriously damage paint. Wipe it off immediately and wash with water if it gets on a painted surface.
- Never allow foreign matter (e.g. dust) and oils other than brake fluid to enter the reservoir tank.

1. Connect the hose to the brake tube, temporarily tighten the flare nut by hand until it does not rotate further, and fix the brake hose to the bracket with the lock plate.

CAUTION:

Check that the brake hoses and tubes are not twisted and bent.

BRAKE PIPING

< REMOVAL AND INSTALLATION >

2. Tighten the flare nut to the specified torque with a flare nut crowfoot and torque wrench.
CAUTION:
Never scratch the flare nut and the brake tube.
3. Refill with new brake fluid and perform the air bleeding. Refer to [BR-11. "Bleeding Brake System"](#).
CAUTION:
Never reuse drained brake fluid.
4. Install tires.

REAR : Inspection

INFOID:000000009949221

INSPECTION AFTER INSTALLATION

1. Check the brake hoses and tubes for the following: no scratches; no twist and deformation; no looseness at connections.
2. Depress the brake pedal with a force of 785 N (80kg, 176 lb) and hold down the pedal for approximately 5 seconds with the engine running. Check for any fluid leakage.
CAUTION:
Retighten the applicable connection to the specified torque and repair any abnormal (damaged, worn or deformed) part if any brake fluid leakage is present.

BRAKE MASTER CYLINDER

< REMOVAL AND INSTALLATION >

BRAKE MASTER CYLINDER

Exploded View

INFOID:000000009949222

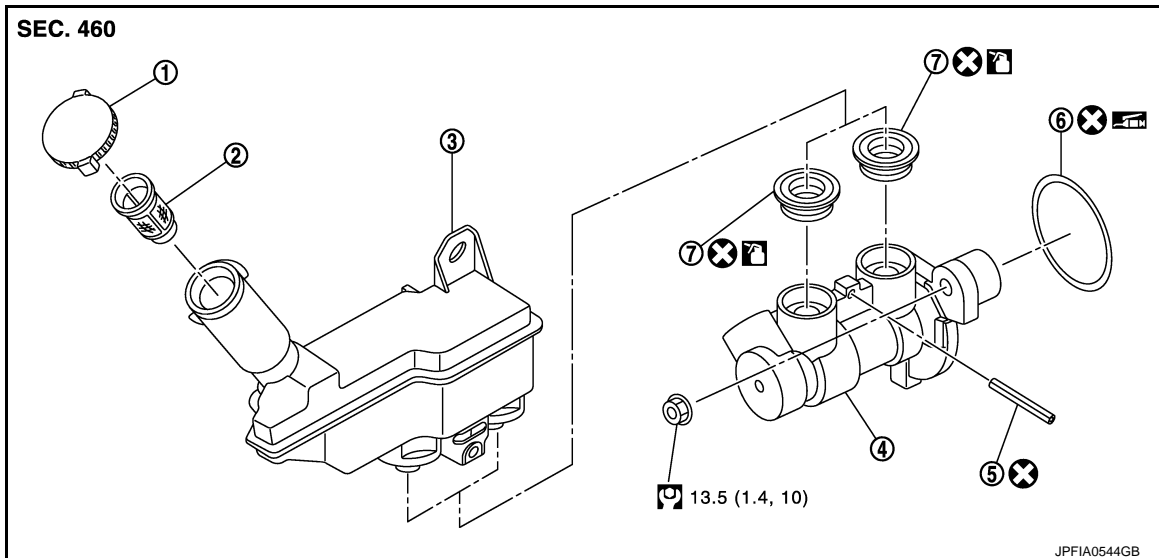

- | | | |
|------------------|-----------------|-------------------|
| 1. Reservoir cap | 2. Oil strainer | 3. Reservoir tank |
| 4. Cylinder body | 5. Pin | 6. O-ring |
| 7. Grommet | | |

: Apply PBC (Poly Butyl Cuprysil) grease or silicone-based grease.

: Apply brake fluid.

Refer to [GI-4, "Components"](#) for symbols not described on the above.

Removal and Installation

INFOID:000000009949223

REMOVAL

CAUTION:

- Never spill or splash brake fluid on painted surfaces. Brake fluid may seriously damage paint. Wipe it off immediately and wash with water if it gets on a painted surface.
- Depress the brake pedal several times to release the vacuum pressure from the brake booster. Then remove the master cylinder assembly.

1. Remove cowl top cover and extension cowl top. Refer to [EXT-19, "Exploded View"](#).
2. Remove air duct and air cleaner case. Refer to [EM-24, "Exploded View"](#).
3. Drain brake fluid. Refer to [BR-10, "Draining"](#).
4. Disconnect the brake fluid level switch harness connector.
5. Remove the brake tube from between ABS actuator and electric unit (control unit) and master cylinder assembly with a flare nut wrench.

CAUTION:

Never scratch the flare nut and the brake tube.

6. Remove the master cylinder assembly.

CAUTION:

- Never deform or bend the brake tubes.
- Never depress the brake pedal after the master cylinder assembly is removed.
- The piston of the master cylinder assembly is exposed. Never damage it when removing the master cylinder.
- The piston may drop off when pulled out strongly. Never hold the piston. Hold the cylinder body when handling the master cylinder assembly.

INSTALLATION

CAUTION:

BRAKE MASTER CYLINDER

< REMOVAL AND INSTALLATION >

Never spill or splash brake fluid on painted surfaces. Brake fluid may seriously damage paint. Wipe it off immediately and wash with water if it gets on a painted surface.

Note the following, and install in the reverse order of removal.

- Never reuse the O-ring.
- Never depress the brake pedal after the master cylinder assembly is removed.
- Apply silicone grease to the brake booster [see (A) in the figure] when installing the master cylinder assembly to the brake booster.
- The piston of the master cylinder assembly is exposed. Never damage it when handling the master cylinder and check that no dirt and dust are present on the piston before installation. Clean it with new brake fluid if necessary.
- The piston may drop off when pulled strongly. Never hold the piston. Hold the cylinder body when handling the master cylinder assembly.
- Never deform or bend the brake tubes.
- Temporarily tighten the brake tube flare nut to the master cylinder assembly by hand. Then tighten it to the specified torque with a flare nut crowfoot and torque wrench. Refer to [BR-20, "FRONT : Exploded View"](#).

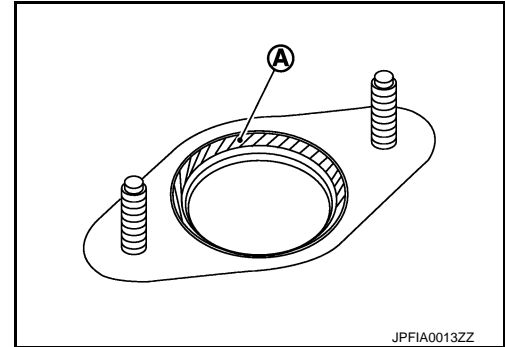

CAUTION:

Never scratch the flare nut and the brake tube.

- Never allow foreign matter (e.g. dust) and oils other than brake fluid to enter the reservoir tank.
- After installation, perform the air bleeding. Refer to [BR-11, "Bleeding Brake System"](#)

CAUTION:

Never reuse drained brake fluid.

- Adjust each item of brake pedal after installing the brake pedal assembly to the vehicle. Refer to [BR-7, "Inspection and Adjustment"](#).

Disassembly and Assembly

INFOID:000000009949224

DISASSEMBLY

CAUTION:

- **Never disassemble the cylinder body.**
- **Remove the reservoir tank only when necessary.**
- **Never drop the removed parts. The parts must not be reused if they are dropped.**

1. Fix the master cylinder assembly to a vise.

CAUTION:

- **Always set copper plates or cloth between vise grips when fixing the cylinder body to a vise.**
- **Never overtighten the vise.**

2. Remove the reservoir tank mounting pin with a pin punch [4 mm (0.157 in)].
3. Remove master cylinder from vise.
4. Remove the reservoir tank and grommet from the cylinder body.

ASSEMBLY

CAUTION:

- **Never use mineral oils such as kerosene or gasoline and rubber grease during the cleaning and assembly process.**
- **Never drop the when installing. The parts must not be reused if they are dropped.**
- **Never allow foreign matter (e.g. dust) and oils other than brake fluid to enter the reservoir tank.**

1. Apply new brake fluid to the grommet and install it to the cylinder body.

CAUTION:

Never reuse the grommets.

2. Install the reservoir tank to the cylinder body.
3. Fix the cylinder body to a vise.

CAUTION:

- **Place the reservoir tank with the chamfered pin hole facing up.**
- **Always set copper plates or cloth between vise grips when fixing the cylinder body to a vise.**
- **Never overtighten the vise.**

BRAKE MASTER CYLINDER

< REMOVAL AND INSTALLATION >

4. Tilt the reservoir tank so that a mounting pin can be inserted. Insert a mounting pin. Return the reservoir tank to the horizontal position. Insert another mounting pin into the pin hole on the opposite side in the same manner after the mounting pin passes through the cylinder body pin hole.

CAUTION:

Never reuse the mounting pin.

Inspection

INFOID:000000009949225

INSPECTION BEFORE REMOVAL

Check the brake fluid level switch. Refer to [BRC-69, "Component Inspection"](#).

INSPECTION AFTER INSTALLATION

Check the following items and replace if necessary.

- Check the master cylinder for deformation, twist, contact with other parts or looseness of connection.
- Check for fluid leakage from connection. Refer to [BR-22, "FRONT : Inspection"](#).

CAUTION:

If the fluid leakage is present, retighten to the specified torque. Replace if necessary.

A
B
C
D
E
G
H
I
J
K
L
M
N
O
P

BR

BRAKE BOOSTER

< REMOVAL AND INSTALLATION >

BRAKE BOOSTER

Exploded View

INFOID:000000009949226

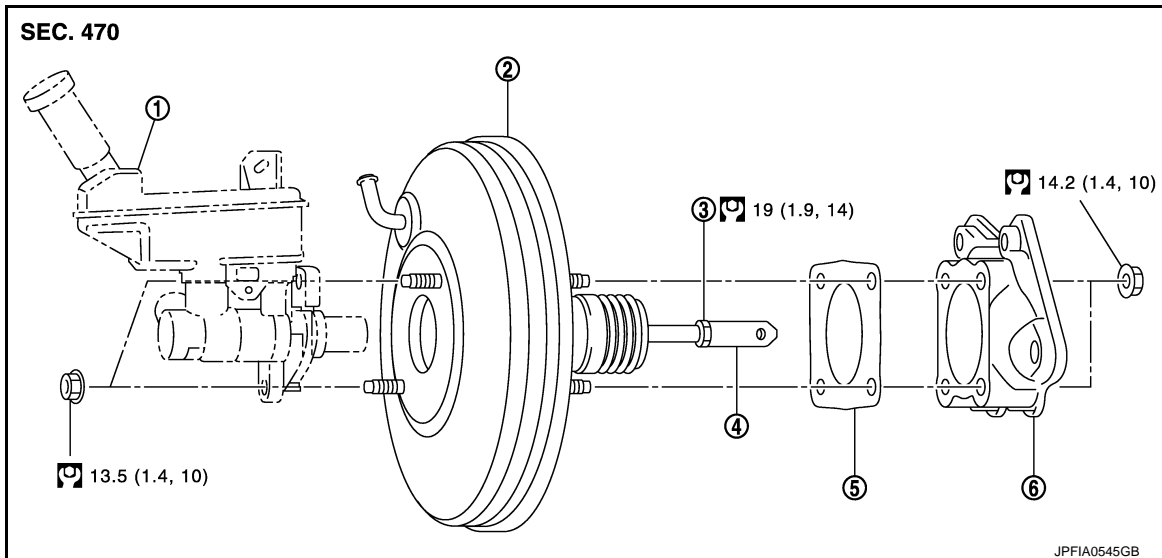

- | | | |
|-----------------------------|------------------|-------------|
| 1. Master cylinder assembly | 2. Brake booster | 3. Lock nut |
| 4. Clevis | 5. Gasket | 6. Spacer |

Refer to [GI-4, "Components"](#) for symbols in the figure.

Removal and installation

INFOID:000000009949227

REMOVAL

CAUTION:

Never spill or splash brake fluid on painted surfaces. Brake fluid may seriously damage paint. Wipe it off immediately and wash with water if it gets on a painted surface.

1. Remove cowl top cover and cowl top extension. Refer to [EXT-19, "Exploded View"](#).
2. Remove air duct and air cleaner case. Refer to [EM-24, "Exploded View"](#).
3. Drain brake fluid. Refer to [BR-10, "Draining"](#).
4. Separate the brake fluid level switch harness connector.
5. Remove the brake tube from between ABS actuator and electric unit (control unit) and master cylinder assembly with a flare nut wrench.

CAUTION:

Never scratch the flare nut and the brake tube.

6. Remove brake master cylinder assembly. Refer to [BR-25, "Exploded View"](#).
7. Remove vacuum hose from brake booster. Refer to [BR-31, "Exploded View"](#).
8. Remove snap pin (1) and clevis pin (2). Refer to [BR-17, "Exploded View"](#).
9. Remove nuts on brake booster and brake pedal assembly. Refer to [BR-17, "Exploded View"](#).
10. Remove brake booster from dash panel in engine room side.

CAUTION:

Never deform or bend the brake tubes.

NOTE:

If removing brake booster is difficult, remove clevis from brake booster.

11. Remove the spacer from brake booster.

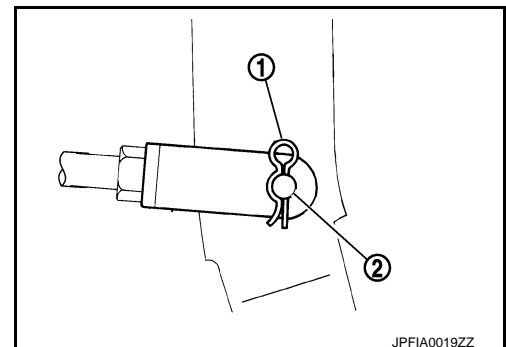

INSTALLATION

CAUTION:

BRAKE BOOSTER

< REMOVAL AND INSTALLATION >

Never spill or splash brake fluid on painted surfaces. Brake fluid may seriously damage paint. Wipe it off immediately and wash with water if it gets on a painted surface.

Note the following, and install in the reverse order of removal.

- Be careful not to damage brake booster stud bolt threads. If brake booster is tilted during installation, the dash panel may damage the threads.
- Never deform or bend the brake tubes.
- Always use a new gasket between the brake booster and the dash panel.
- Replace the clevis pin if it is damaged. Refer to [BR-18, "Inspection and Adjustment"](#).
- Never allow foreign matter (e.g. dust) and oils other than brake fluid to enter the reservoir tank.
- After installation, perform the air bleeding. Refer to [BR-11, "Bleeding Brake System"](#).

CAUTION:

Never reuse drained brake fluid.

- Check each item of brake pedal. Adjust it if the measurement value is not the standard. Refer to [BR-7, "Inspection and Adjustment"](#).

Inspection and Adjustment

INFOID:000000009949228

INSPECTION BEFORE REMOVAL

Air Tight

CAUTION:

Check the air tight condition when the master cylinder and the brake booster is installed.

1. With a handy vacuum pump, apply vacuum pressure of -66.7 kPa (-500 mmHg, -19.70 inHg) to the brake booster.
2. If the air tight condition cannot be maintained, perform the following operation.
 - a. Check the no dirt and dust are present on the brake booster and brake master cylinder mating faces. Clean it if necessary.
 - b. Check the O-ring on the master cylinder. If anything is found, replace the O-ring.
 - c. Check the air tight condition again. If the condition still cannot be maintained, replace the brake booster.

INSPECTION AFTER REMOVAL

Input Rod Length Inspection

1. Loosen the lock nut (1) and adjust the input rod (2) to the specified length (A).

A : Refer to [BR-43, "Brake Booster"](#).

2. Tighten the lock nut to the specified torque.

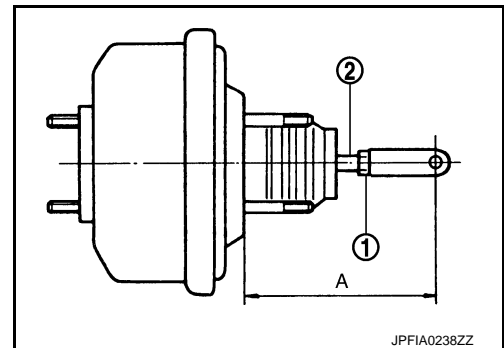

INSPECTION AFTER INSTALLATION

Operation

Depress the brake pedal several times at 5-second intervals with the engine stopped. Start the engine with the brake pedal fully depressed. Check that the clearance between brake pedal and dash lower pane decreases.

Air Tight

1. Run the engine for 1 minute to apply vacuum to the brake booster, and stop the engine. Then depress the brake pedal several times at 5-second intervals until the accumulated vacuum is released to atmospheric pressure. Check that the clearance between brake pedal and dash lower panel gradually increases each time the brake pedal is depressed when performing this operation.
2. Depress the brake pedal with the engine running. Then stop the engine while holding down the brake pedal. Check that the brake pedal stroke does not change after holding down the brake pedal for 30 seconds or more.

ADJUSTMENT AFTER INSTALLATION

BRAKE BOOSTER

< REMOVAL AND INSTALLATION >

Perform the brake pedal adjustment after installing the brake pedal assembly. Refer to [BR-7. "Inspection and Adjustment"](#).

VACUUM LINES

< REMOVAL AND INSTALLATION >

VACUUM LINES

Exploded View

INFOID:000000009949229

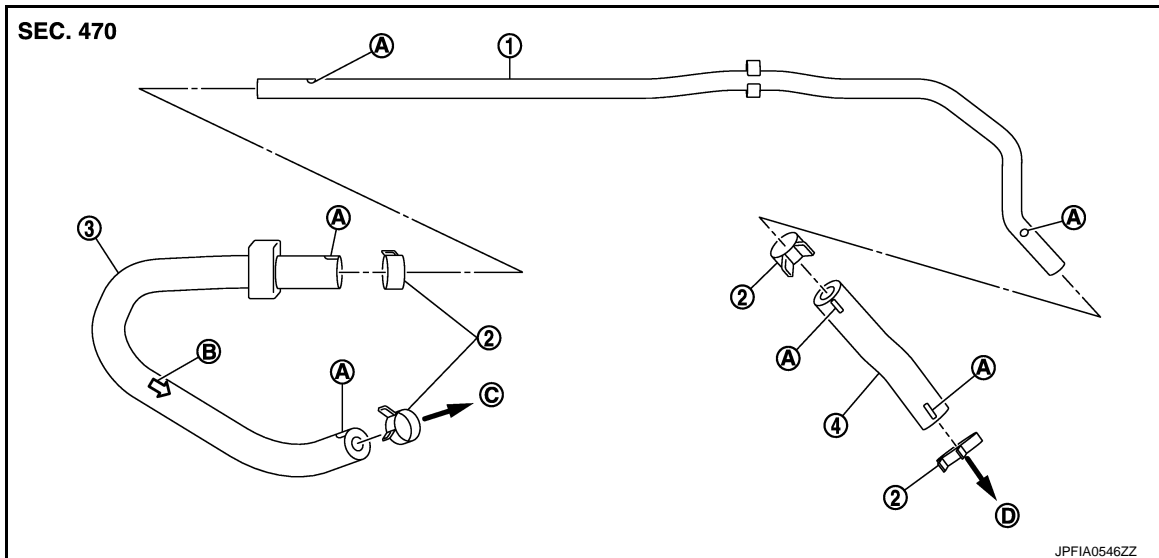

- | | | |
|---------------------|--------------------------------------|---------------------------------------|
| 1. Vacuum piping | 2. Clamp | 3. Vacuum hose (built-in check valve) |
| 4. Vacuum hose | | |
| A. Paint mark | B. Stamp indicating engine direction | C. To intake manifold |
| D. To brake booster | | |

Removal and Installation

INFOID:000000009949230

REMOVAL

1. Remove the air duct. Refer to [EM-24, "Exploded View"](#).
2. Remove the vacuum hose and vacuum piping.

INSTALLATION

Note the following, install in the reverse order of removal.

- Because vacuum hose contains a check valve, it must be installed in the correct position. Refer to the stamp to confirm correct installation. Brake booster will not operate normally if the hose is installed in the wrong direction.
- When installing vacuum hose, insert it until its tip reaches the back-end of length (A) or further as shown in the figure.

A : 24 mm (0.95 in) or more

- Face the paint marks of vacuum hose and vacuum piping (brake hose side) to vehicle front side to assemble.

CAUTION:

Never use lubricating oil during assembly.

- Face the paint marks of vacuum hose (built-in check valve) and vacuum piping (intake manifold side) to the upward to assemble.

CAUTION:

Never use lubricating oil during assembly.

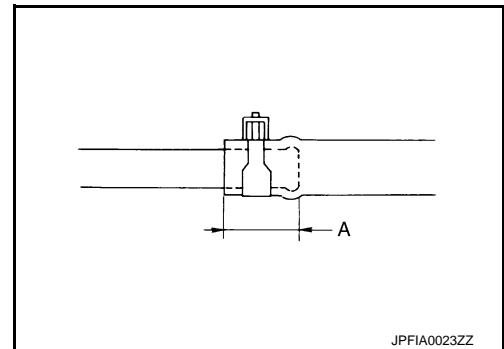

Inspection

INFOID:000000009949231

INSPECTION AFTER REMOVAL

Appearance

Check for correct assembly, damage and deterioration.

VACUUM LINES

< REMOVAL AND INSTALLATION >

Check Valve Airtightness

- Use a handy vacuum pump (A) to check.

When connected to the booster side (B):

Vacuum should decrease within 1.3 kPa (9.8 mm-Hg, 0.38 inHg) for 15 seconds under a vacuum of –66.7 kPa (–500 mmHg, –19.69 inHg).

When connected to the engine side (C):

Vacuum should not exist.

- Replace vacuum hose assembly if vacuum hose and check valve are malfunctioning.

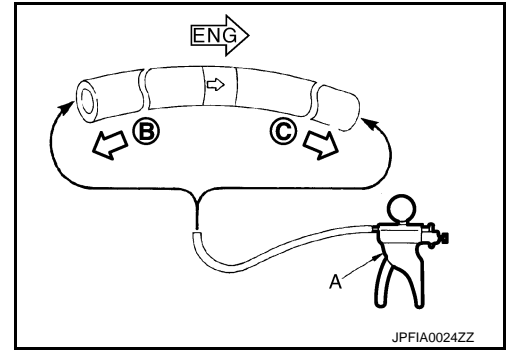

FRONT DISC BRAKE

< REMOVAL AND INSTALLATION >

FRONT DISC BRAKE

BRAKE PAD

BRAKE PAD : Exploded View

INFOID:000000009949232

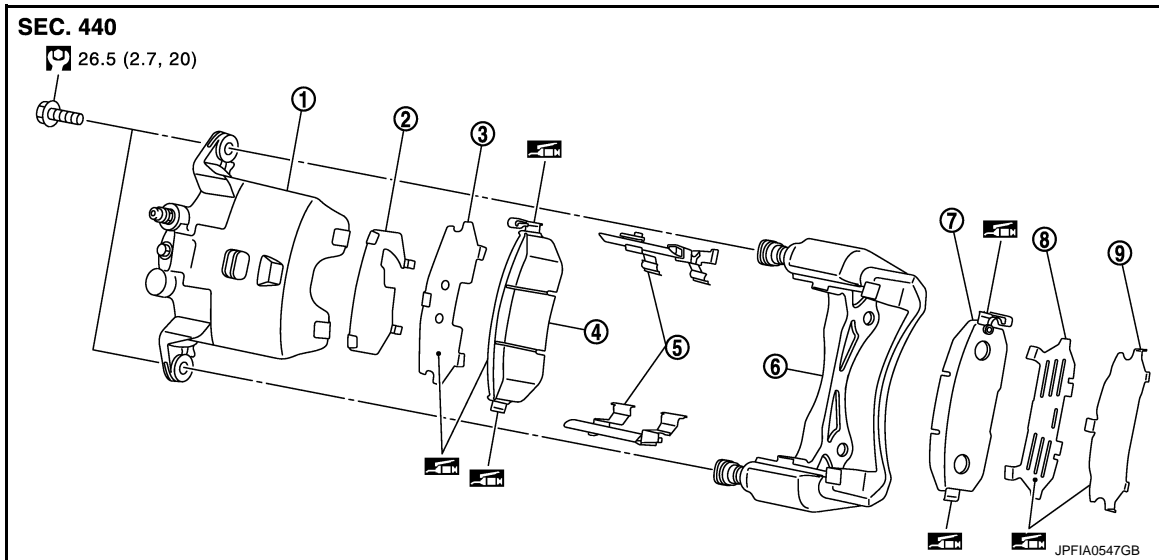

- | | | |
|-------------------------------------|---------------------|---------------------|
| 1. Cylinder body | 2. Inner shim cover | 3. Inner shim |
| 4. Inner pad (with pad wear sensor) | 5. Pad retainer | 6. Torque member |
| 7. Outer pad (with pad wear sensor) | 8. Outer shim | 9. Outer shim cover |

Apply PBC (Poly Butyl Cuprysil) grease or silicone-based grease.

Refer to [GI-4, "Components"](#) for symbols not described on the above.

BRAKE PAD : Removal and Installation

INFOID:000000009949233

REMOVAL

WARNING:

Since dust covering the front brake has an affect on human body, the dust must be removed with a dust collector. Never splatter the dust with an air blow gun.

CAUTION:

- Never depress the brake pedal while removing the brake pads because the piston may pop out.
- Never spill or splash brake fluid on the disc rotor.

1. Remove tires with power tool.
2. Remove lower sliding pin bolt.
3. Suspend the cylinder body with suitable wire so that the brake hose will not stretch. Then remove the brake pads, shims, shim covers and pad retainers from the torque member.

CAUTION:

- Never deform the pad retainer when removing the pad retainer from the torque member.
- Never damage the piston boot.
- Never drop the brake pads, shims, and the shim covers.
- Remember each position of the removed brake pads.

INSTALLATION

WARNING:

Since dust covering the front brake has an affect on human body, the dust must be removed with a dust collector. Never splatter the dust with an air blow gun.

CAUTION:

- Never depress the brake pedal while removing the brake pads or the cylinder body because the piston may pop out.
- Never spill or splash brake fluid on the disc rotor.

FRONT DISC BRAKE

< REMOVAL AND INSTALLATION >

1. Install the pad retainers to the torque member if the pad retainers has been removed.
CAUTION:
 - **Securely assemble the pad retainers so that it will not be lifted up from the torque member.**
 - **Never deform the pad retainers.**
2. Apply PBC (Poly Butyl Cuprysil) grease or silicone-based grease to the mating faces between the inner shim and the inner pad, and install them to the inner pad.
CAUTION:
Always replace the shim together with the shim cover when replacing the brake pad.
3. Apply PBC (Poly Butyl Cuprysil) grease or silicone-based grease to the mating faces between the outer shim and the outer shim cover, and install them to the outer pad.
CAUTION:
Always replace the shim together with the shim cover when replacing the brake pad.
4. Apply PBC (Poly Butyl Cuprysil) grease or silicone-based grease to the mating faces between the brake pads and the pad retainers, and Install the brake pads to the torque member.
5. Install cylinder body to torque member.
CAUTION:
 - **Never damage the piston boot.**
 - **When replacing brake pad with new one, check a brake fluid level in the reservoir tank because brake fluid returns to master cylinder reservoir tank when pressing piston in.****NOTE:**
Use a disc brake piston tool to easily press piston.
6. Install the lower sliding pin bolt and tighten it to the specified torque.
7. Depress the brake pedal several times to check that no drag feel is present for the front disc brake. Refer to [BR-34, "BRAKE PAD : Inspection"](#).
8. Install tires.

BRAKE PAD : Inspection

INFOID:000000009949234

INSPECTION AFTER REMOVAL

Replace the shims and the shim covers if rust is excessively attached.

INSPECTION AFTER INSTALLATION

1. Check a drag of front disc brake. If any drag is found, follow the procedure described below.
2. Remove brake pads. Refer to [BR-33, "BRAKE PAD : Exploded View"](#).
3. Press the pistons. Refer to [BR-33, "BRAKE PAD : Removal and Installation"](#).
4. Install brake pads. Refer to [BR-33, "BRAKE PAD : Exploded View"](#).
5. Depress the brake pedal several times.
6. Check a drag of front disc brake again. If any drag is found, disassemble the cylinder body. Refer to [BR-36, "BRAKE CALIPER ASSEMBLY : Disassembly and Assembly"](#)
7. Burnish contact surfaces brake pads and disc rotor after refinishing or replacing brake pads, or if a soft pedal occurs at very low mileage. Refer to [BR-14, "BRAKE PAD : Inspection and Adjustment"](#).

BRAKE CALIPER ASSEMBLY

BRAKE CALIPER ASSEMBLY : Exploded View

INFOID:000000009949235

REMOVAL

FRONT DISC BRAKE

< REMOVAL AND INSTALLATION >

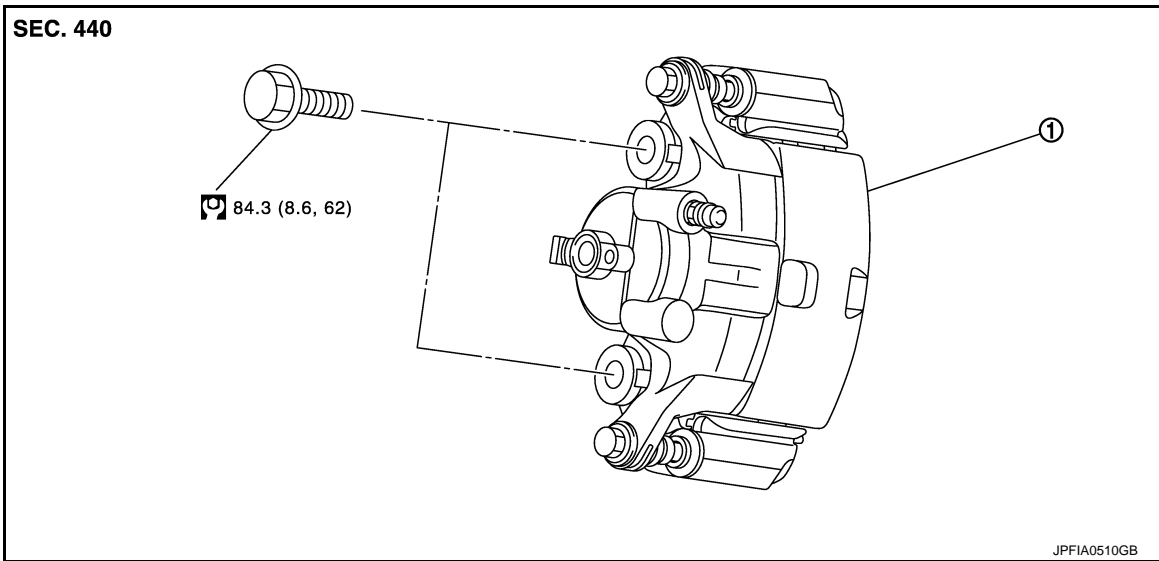

1. Brake caliper assembly

Refer to [GI-4, "Components"](#) for symbols in the figure.

DISASSEMBLY

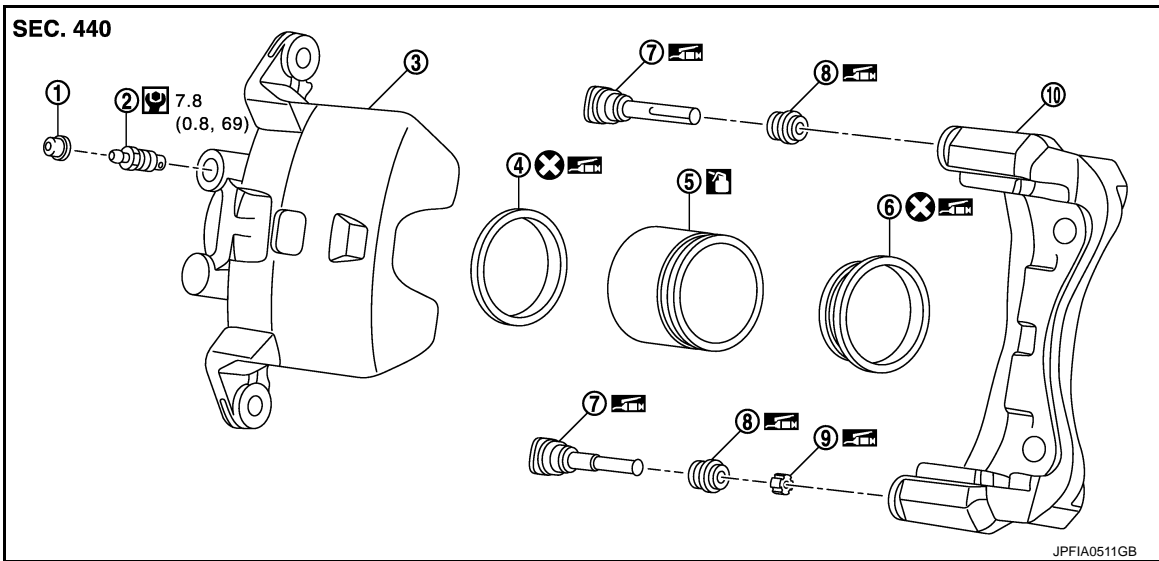

- | | | |
|-------------------|---------------------|------------------|
| 1. Cap | 2. Bleeder valve | 3. Cylinder body |
| 4. Piston seal | 5. Piston | 6. Piston boot |
| 7. Sliding pin | 8. Sliding pin boot | 9. Bushing |
| 10. Torque member | | |

: Apply rubber grease.

: Apply brake fluid.

Refer to [GI-4, "Components"](#) for symbols not described on the above.

BRAKE CALIPER ASSEMBLY : Removal and Installation

INFOID:000000009949236

REMOVAL

WARNING:

Since dust covering the front brake has an affect on human body, the dust must be removed with a dust collector. Never splatter the dust with an air blow gun.

FRONT DISC BRAKE

< REMOVAL AND INSTALLATION >

CAUTION:

Never spill or splash brake fluid on painted surfaces. Brake fluid may seriously damage paint. Wipe it out immediately and wash with water if it gets on a protect surface.

1. Remove tires with power tool.
2. Fix the disc rotor using wheel nuts.
3. Drain brake fluid. Refer to [BR-10, "Draining"](#).

CAUTION:

Never spill or splash brake fluid on the disc rotor.

4. Remove union bolt and copper washer, and disconnect brake hose from caliper assembly. Refer to [BR-20, "FRONT : Exploded View"](#).

CAUTION:

Never depress the brake pedal. Brake fluid may splash while removing the brake hose.

5. Remove torque member mounting bolts, and remove brake caliper assembly.

CAUTION:

Never drop brake pad and caliper assembly.

6. Remove disc rotor.

CAUTION:

- Put matching marks on the wheel hub and bearing assembly and the disc rotor before removing the disc rotor.
- Never drop disc rotor.

INSTALLATION

WARNING:

Since dust covering the front brake has an affect on human body, the dust must be removed with a dust collector. Never splatter the dust with an air blow gun.

CAUTION:

- Never depress the brake pedal. Brake fluid may splash while removing the brake hose.
- Never spill or splash brake fluid on painted surfaces. Brake fluid may seriously damage paint. Wipe it out immediately and wash with water if it gets on a protect surface.
- Never allow foreign matter (e.g. dust) and oils other than brake fluid to enter the reservoir tank.

1. Install disc rotor.

CAUTION:

Align the matching marks that have been made during removal when reusing the disc rotor.

2. Install the brake caliper assembly to the steering knuckle and tighten the torque member mounting bolts to the specified torque.

CAUTION:

Never spill or splash any grease and moisture on the brake caliper assembly mounting face, threads, mounting bolts and washers. Wipe out any grease and moisture.

3. Install brake hose and copper washers to brake caliper assembly, and tighten union bolts to the specified torque. Refer to [BR-20, "FRONT : Exploded View"](#).

CAUTION:

Never reuse copper washer.

4. Refill with new brake fluid and perform the air bleeding. Refer to [BR-11, "Bleeding Brake System"](#).

CAUTION:

- Never reuse drained brake fluid.
- Never spill or splash brake fluid on the disc rotor.

5. Check a drag of front disc brake. If any drag is found, refer to [BR-38, "BRAKE CALIPER ASSEMBLY : Inspection"](#).

6. Install tires.

BRAKE CALIPER ASSEMBLY : Disassembly and Assembly

INFOID:000000009949237

DISASSEMBLY

NOTE:

Never remove the torque member, brake pad and pad retainers when disassembling and assembling the cylinder body.

1. Remove the sliding pin bolt, and remove the cylinder body from the torque member. Refer to [BR-33, "BRAKE PAD : Exploded View"](#).

FRONT DISC BRAKE

< REMOVAL AND INSTALLATION >

CAUTION:

Fix the brake pad at suitable tape so that the brake pad will not drop.

2. Remove sliding pins and sliding pin boots from torque member.
3. Remove bushing from sliding pin.
4. Place a wooden block as shown in the figure, and blow air from union bolt mounting hole to remove pistons and piston boots.

CAUTION:

Never get fingers caught in the pistons.

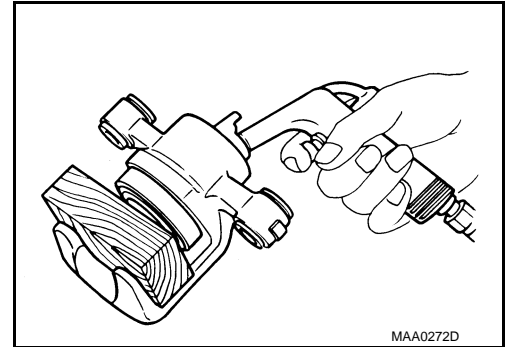

5. Remove piston seal from cylinder body using suitable tool.

CAUTION:

Be careful not to damage a cylinder inner wall.

6. Remove bleeder valve and cap.

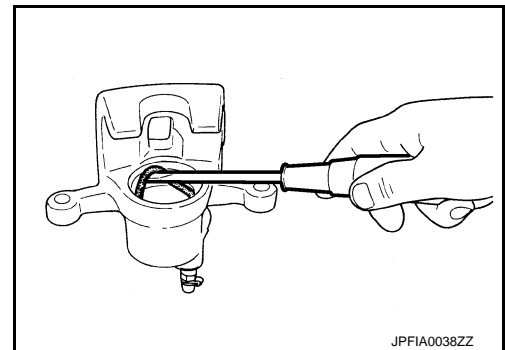

ASSEMBLY

1. Install bleeder valve and cap.
2. Apply rubber grease to piston seals (1), and install them to cylinder body.

CAUTION:

Never reuse piston seals.

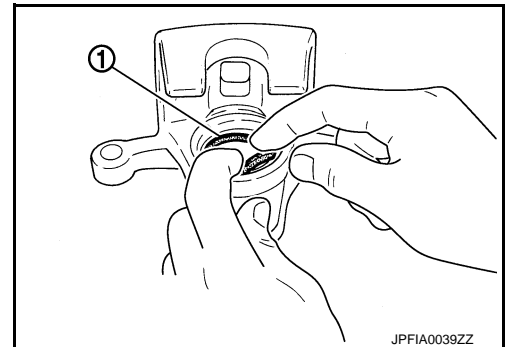

3. Apply rubber grease to piston boots (1). Cover the piston (2) end with piston boot, and then install cylinder side lip on piston boot securely into a groove on cylinder body.

CAUTION:

Never reuse piston boots.

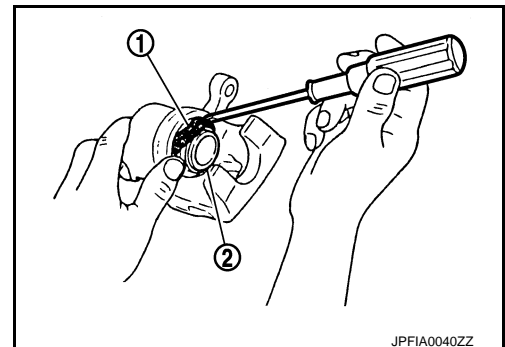

A
B
C
D
E
BR
G
H
I
J
K
L
M
N
O
P

FRONT DISC BRAKE

< REMOVAL AND INSTALLATION >

4. Apply brake fluid to pistons (1). Push piston into cylinder body by hand and push piston boot (2) piston-side lip into the piston groove.

CAUTION:

Press the pistons evenly and vary the pressing point to prevent cylinder inner wall from being rubbed.

5. Apply rubber grease to bushing, and install bushing to sliding pin.
6. Apply rubber grease to sliding pins and sliding boots, and install sliding pins and sliding pin boots to torque member.
7. Install the cylinder body to tighten cylinder body mounting bolts to the specified torque.

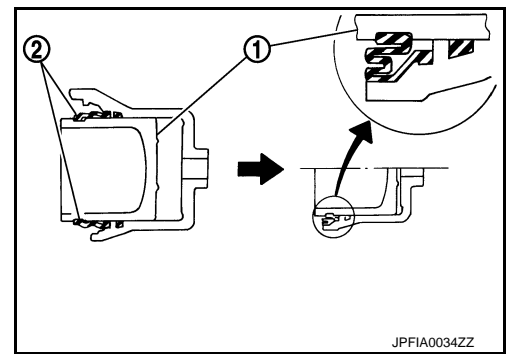

BRAKE CALIPER ASSEMBLY : Inspection

INFOID:000000009949238

INSPECTION AFTER DISASSEMBLY

Check the following items and replace if necessary.

Cylinder Body

Check the inner wall of the cylinder for rust, wear, cracks or damage.

CAUTION:

Always clean with new brake fluid. Never clean with mineral oil such as gasoline and light oil.

Torque Member

Check the torque member for rust, wear, cracks or damage.

Pistons

Check the surface of the piston for rust, wear, cracks or damage.

CAUTION:

A piston sliding surface is plated. Never polish with sandpaper.

Sliding Pin and Sliding Pin Boot

Check the sliding pins and sliding boots for rust, wear, cracks or damage.

INSPECTION AFTER INSTALLATION

1. Check a drag of front disc brake. If any drag is found, follow the procedure described below.
2. Remove brake pads. Refer to [BR-33, "BRAKE PAD : Exploded View"](#).
3. Press the pistons. Refer to [BR-33, "BRAKE PAD : Removal and Installation"](#).
4. Install brake pads. Refer to [BR-33, "BRAKE PAD : Exploded View"](#).
5. Depress the brake pedal several times.
6. Check a drag of front disc brake again. If any drag is found, disassemble the cylinder body. Refer to [BR-36, "BRAKE CALIPER ASSEMBLY : Disassembly and Assembly"](#).
7. Burnish contact surface between disc rotor and brake pads after refinishing or replacing disc rotor, or if a soft pedal occurs at very low mileage. Refer to [BR-14, "DISC ROTOR : Inspection and Adjustment"](#).

REAR DRUM BRAKE

< REMOVAL AND INSTALLATION >

REAR DRUM BRAKE

Exploded View

INFOID:000000009949239

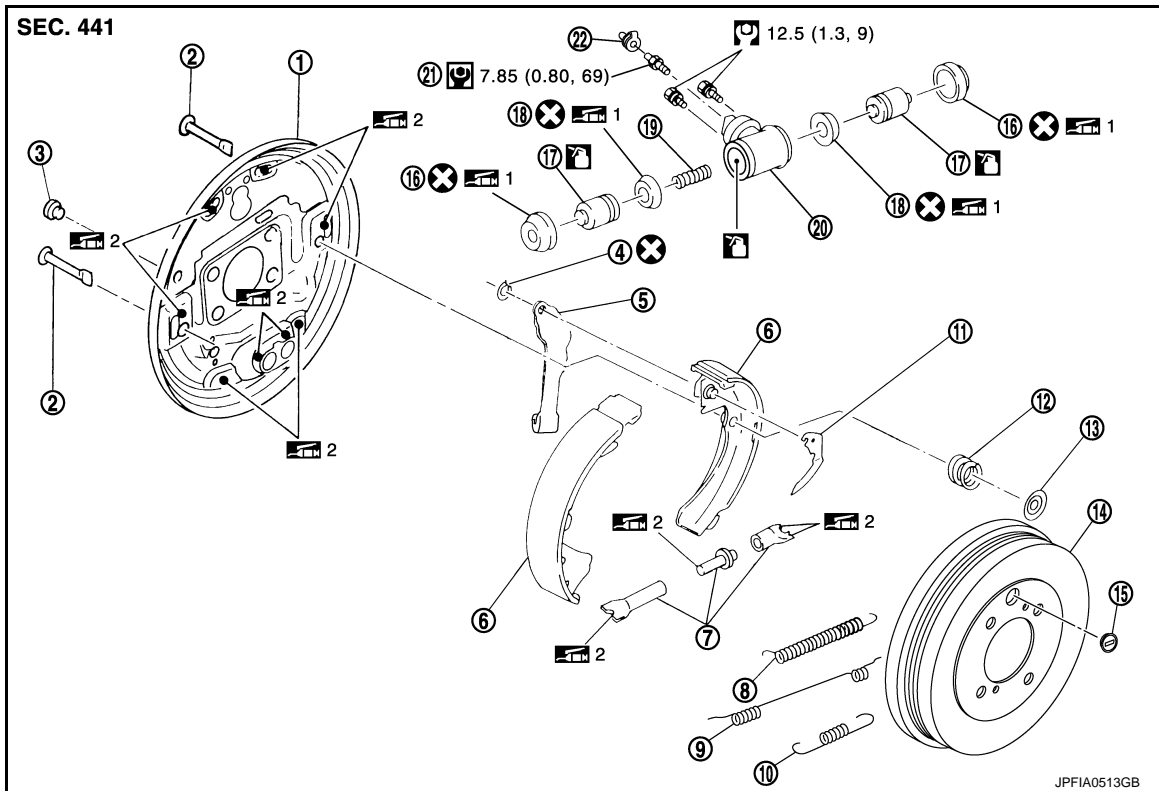

- | | | |
|--------------------------------|--------------------|-------------------------------|
| 1. Back plate | 2. Shoe hold pin | 3. Plug |
| 4. Retainer ring | 5. Operating lever | 6. Brake shoe |
| 7. Adjuster | 8. Adjuster spring | 9. Return spring (upper side) |
| 10. Return spring (lower side) | 11. Adjuster lever | 12. Spring |
| 13. Retainer | 14. Brake drum | 15. Plug |
| 16. Boot | 17. Piston | 18. Piston cup |
| 19. Spring | 20. Wheel cylinder | 21. Bleed valve |
| 22. Cap | | |

1: Apply polyglycol ether based lubricant.

2: Apply PBC (Poly Butyl Cuprysil) grease or silicone-based grease.

: Apply brake fluid

Refer to [GI-4. "Components"](#) for symbols not described on the above.

Removal and Installation

INFOID:000000009949240

REMOVAL

WARNING:

Since dust covering the rear brake has an affect on human body, the dust must be removed with a dust collector. Never splatter the dust with an air blow gun.

CAUTION:

- Never depress the brake pedal while removing the brake pads drum.
- Never drop the removed parts.

1. Remove tires with power tool.
2. Perform drain the brake fluid when remove or disassemble the wheel cylinder. Refer to [BR-10. "Draining"](#).

REAR DRUM BRAKE

< REMOVAL AND INSTALLATION >

3. Remove the brake drum with the parking brake lever. If brake drum is difficult to the brake drum, remove it with the following procedure.
 - a. Remove the plug from brake drum.
 - b. Pull the adjuster lever (2) from the plug hole of brake drum (1) using a suitable wire (A), rotate the adjuster (3) in the direction (←) using a suitable tool (B), and then compress the expanded brake shoe.
4. Press and rotate the retainer, and then remove the retainer, spring and shoe hold pin.

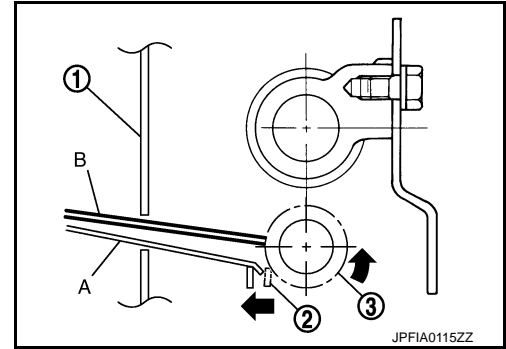

5. Remove the brake shoe assembly (brake shoe, each spring, adjuster and adjuster lever).

CAUTION:

Never damage the boot of the wheel cylinder.

6. Remove the parking brake cable from operating lever.

CAUTION:

Never bend sharply the parking brake lever.

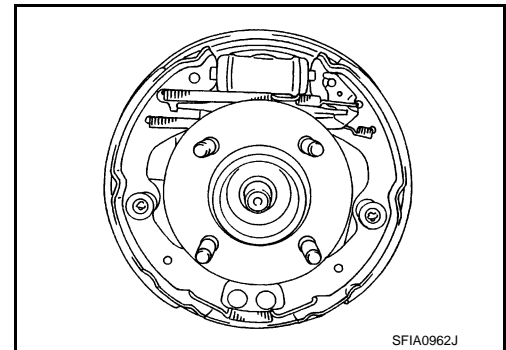

7. Disassemble the brake shoe assembly (brake shoe, each spring, adjuster and adjuster lever).

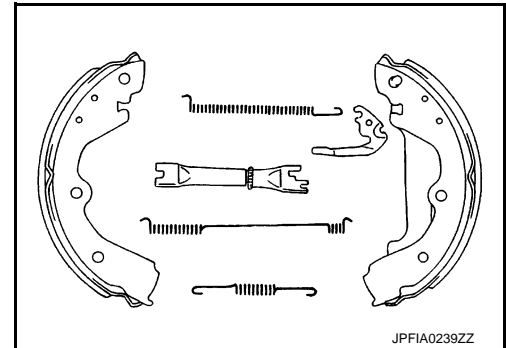

8. Open the joint (A) of retainer ring (1) and remove the retainer ring to remove the operating lever (2) from the brake shoe pin (3).
9. Separate the brake tube from the wheel cylinder.
10. Remove the wheel cylinder from back plate.

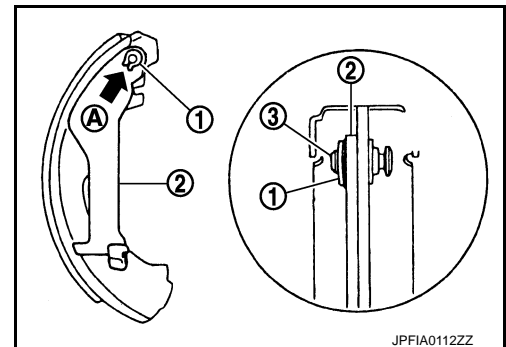

INSTALLATION

WARNING:

Since dust covering the rear brake has an affect on human body, the dust must be removed with a dust collector. Never splatter the dust with an air blow gun.

CAUTION:

- Never depress the brake pedal while removing the brake drum.
- Never spill or splash brake fluid on the brake drum.

Note the following, and install in the reverse of removal.

REAR DRUM BRAKE

< REMOVAL AND INSTALLATION >

- After installing the retainer ring, close the joint of retainer ring until securely closed.
- When disassembled adjuster, confirm the difference between left and right wheel for assemble.

Adjuster	Direction
Left side	Left screw
Right side	Right screw

- Apply PBC (Poly Butyl Cuprysil) silicone-based grease to the adjuster screw.
- Apply PBC (Poly Butyl Cuprysil) silicone-based grease to the mating faces between the adjuster and brake shoe.
- Apply PBC (Poly Butyl Cuprysil) silicone-based grease to the mating faces between the back plate and brake shoe.
- Shorten adjuster by rotating it.
- Install the brake shoe assembly so that it does damage the wheel cylinder.
- Check the component parts of brake shoe assembly are installed properly.
- Check the brake shoe sliding surface and brake drum inner surface for grease. Wipe it out any adheres to the surfaces.
- Perform the air bleeding when removed or disassembled the wheel cylinder. Refer to [BR-11. "Bleeding Brake System"](#).
- Never allow foreign matter (e.g. dust) and oils other than brake fluid to enter the reservoir tank.
- Adjust the brake shoe (parking brake lever stroke) after install and air bleeding. Refer to [PB-3. "Inspection and Adjustment"](#).

Disassembly and Assembly

INFOID:000000009949241

DISASSEMBLY

1. Remove the boot from wheel cylinder. Refer to [BR-39. "Exploded View"](#).
2. Remove the piston, piston cup and spring from wheel cylinder.
CAUTION:
Pull the piston out from the wheel cylinder to prevent the wheel cylinder inner wall from being damaged.
3. Remove boot and piston cup from piston.

ASSEMBLY

1. Apply polyglycol ether based lubricant to the piston cup (1) and boot (2), and install them to piston (3).
CAUTION:
 - **Never mistake the direction.**
 - **Never reuse piston cup and boot.**
2. Apply brake fluid to piston and wheel cylinder inner wall, and install spring and piston to wheel cylinder.
CAUTION:
Never damage the wheel cylinder inner wall.
3. Install the boot to wheel cylinder. Refer to [BR-39. "Exploded View"](#).

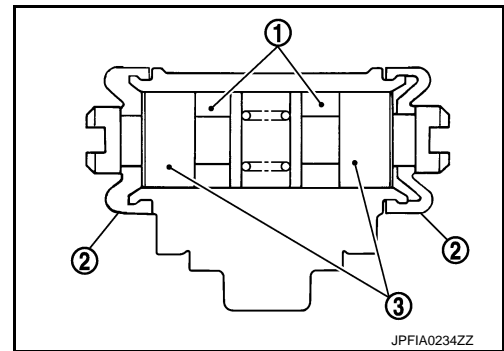

Inspection and Adjustment

INFOID:000000009949242

INSPECTION AFTER REMOVAL

Check the following items and replace if necessary.

- Check the brake lining for excessive wear, damage, and peeling.
- Check the brake shoe sliding surface for excessive wear and damage.
- Check each spring for settling, excessive wear, damage, and rust.
- Check the adjuster for smoothness, and check it for excessive wear, damage, and rust.
- Check the back plate for damage, cracks, and deformation.
- Check the wheel cylinder for cracks, damage, and leakage of brake fluid.
- Visually check the brake drum for excessive wear, cracks, and damage with a pair of vernier calipers.
- Check the drum brake component parts for excessive wear, damage, and rust.

INSPECTION AFTER DISASSEMBLY

REAR DRUM BRAKE

< REMOVAL AND INSTALLATION >

Check the following items and replace if necessary.

- Check the wheel cylinder inner wall for excessive wear, cracks, and damage.
- Check the piston for excessive wear and damage.

INSPECTION AFTER ASSEMBLY

Check that the piston moves smoothly.

INSPECTION AFTER INSTALLATION

1. Check that the component parts of drum brake assembly are installed properly.
2. Rotate the brake drum and check that there is no drag. Perform the following procedure if necessary.
 - a. Remove the brake shoe. Refer to [BR-39, "Exploded View"](#).
 - b. Push the piston.
CAUTION:
Push both side of the piston simultaneously.
 - c. Install the brake shoe. Refer to [BR-39, "Exploded View"](#).
 - d. Operate the brake pedal with a force of 196 N (20 kg, 44 lb) for 10 strokes or more.
 - e. Check a drag of rear disc brake again. If any drag is found, disassemble the wheel cylinder. Refer to [BR-41, "Disassembly and Assembly"](#).

ADJUSTMENT AFTER INSTALLATION

Adjust the brake shoe (parking brake lever stroke). Refer to [PB-3, "Inspection and Adjustment"](#).

SERVICE DATA AND SPECIFICATIONS (SDS)

< SERVICE DATA AND SPECIFICATIONS (SDS)

SERVICE DATA AND SPECIFICATIONS (SDS)

SERVICE DATA AND SPECIFICATIONS (SDS)

General Specifications

INFOID:0000000009949243

Unit: mm (in)

Front brake	Cylinder bore diameter	57.2 (2.252)
	Pad length × width × thickness	118.6 × 46.0 × 9.5 (4.67 × 1.811 × 0.374)
	Rotor outer diameter × thickness	280 × 24.0 (11.02 × 0.945)
Rear brake	Cylinder bore diameter	19.05 (0.750)
	Lining length × width × thickness	218.6 × 35.0 × 4.0 (8.61 × 1.378 × 0.157)
	Drum inner diameter	228.6 (9.00)
Master cylinder	Cylinder bore diameter	23.81 (15/16)
Control valve	Valve type	Electric brake force distribution
Brake booster	Diaphragm diameter	254 (10.00)
Recommended brake fluid		Refer to MA-10, "Fluids and Lubricants"

Brake Pedal

INFOID:0000000009949244

Unit: mm (in)

Item		Standard
Brake pedal height	M/T	162.3 – 172.3 (6.39 – 6.78)
	CVT	172.4 – 182.4 (6.79 – 7.18)
Clearance among the brake pedal lever and the stop lamp switch threaded end		0.74 – 1.96 (0.0291 – 0.0772)
Clearance among the brake pedal bracket and the ASCD brake switch threaded end (with ASCD)		0.74 – 1.96 (0.0291 – 0.0772)
Brake pedal play		3 – 11 (0.12 – 0.43)
Depressed brake pedal height [Depressing 490 N (50 kg, 110 lb) while turning the engine ON]	M/T	80 (3.15) or more
	CVT	85 (3.35) or more

Brake Booster

INFOID:0000000009949245

Unit: mm (in)

Item	Standard
Input rod length	158.5 – 159.5 (6.24 – 6.28)

Front Disc Brake

INFOID:0000000009949246

Unit: mm (in)

Item		Limit
Brake pad	Wear thickness	2.0 (0.079)
	Wear thickness	22.0 (0.866)
Disc rotor	Thickness variation (measured at 8 positions)	0.015 (0.0006)
	Runout (with it attached to the vehicle)	0.035 (0.0014)

Rear Drum Brake

INFOID:0000000009949247

Unit: mm (in)

Item		Limit
Brake lining	Wear thickness	1.5 (0.059)
Brake drum	Wear inner diameter	230.0 (9.06)