

SECTION CO

ENGINE COOLING SYSTEM

CONTENTS

SYSTEM DESCRIPTION	2	REMOVAL AND INSTALLATION	14	A
DESCRIPTION	2	RADIATOR	14	
Engine Cooling System	2	Exploded View	14	G
Engine Cooling System Schematic	3	Removal and Installation	14	
SYMPTOM DIAGNOSIS	4	Inspection	16	
OVERHEATING CAUSE ANALYSIS	4	COOLING FAN	17	H
Troubleshooting Chart	4	Exploded View	17	
PRECAUTION	6	Removal and Installation	17	
PRECAUTIONS	6	Disassembly and Assembly	18	I
Precautions for Removing of Battery Terminal	6	Inspection	18	
Precaution for Supplemental Restraint System (SRS) "AIR BAG" and "SEAT BELT PRE-TENSIONER"	6	WATER PUMP	19	J
PREPARATION	7	Exploded View	19	
PREPARATION	7	Removal and Installation	19	K
Commercial Service Tools	7	Inspection	19	
PERIODIC MAINTENANCE	8	THERMOSTAT	21	L
ENGINE COOLANT	8	Exploded View	21	
Inspection	8	Removal and Installation	21	
Draining	8	Inspection	22	M
Refilling	9	WATER OUTLET	23	
Flushing	10	Exploded View	23	
RADIATOR	12	Removal and Installation	23	N
RADIATOR CAP	12	Inspection	24	
RADIATOR CAP : Inspection	12	SERVICE DATA AND SPECIFICATIONS (SDS)	25	O
RADIATOR	12	SERVICE DATA AND SPECIFICATIONS (SDS)	25	
RADIATOR : Inspection	12	Periodical Maintenance Specification	25	P
		Radiator	25	
		Thermostat	25	
		Water Control Valve	25	

DESCRIPTION

< SYSTEM DESCRIPTION >

SYSTEM DESCRIPTION

DESCRIPTION

Engine Cooling System

INFOID:000000009950388

M/T models

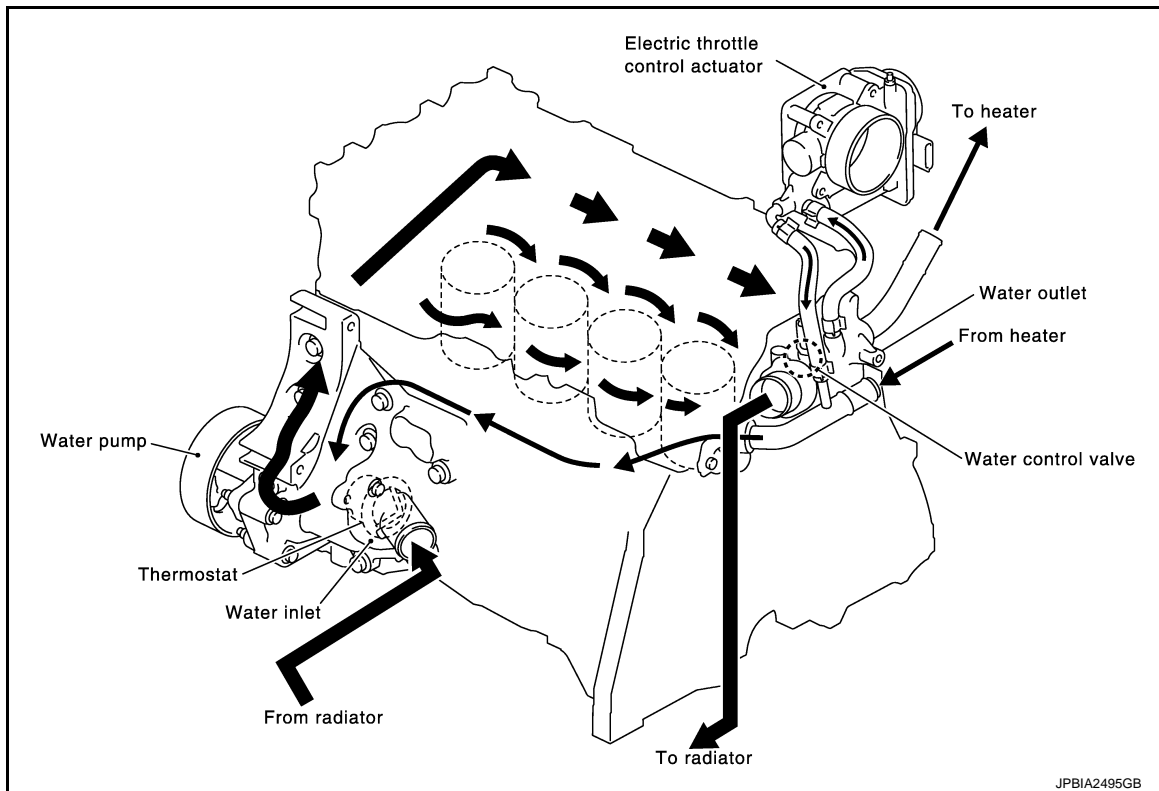

CVT models

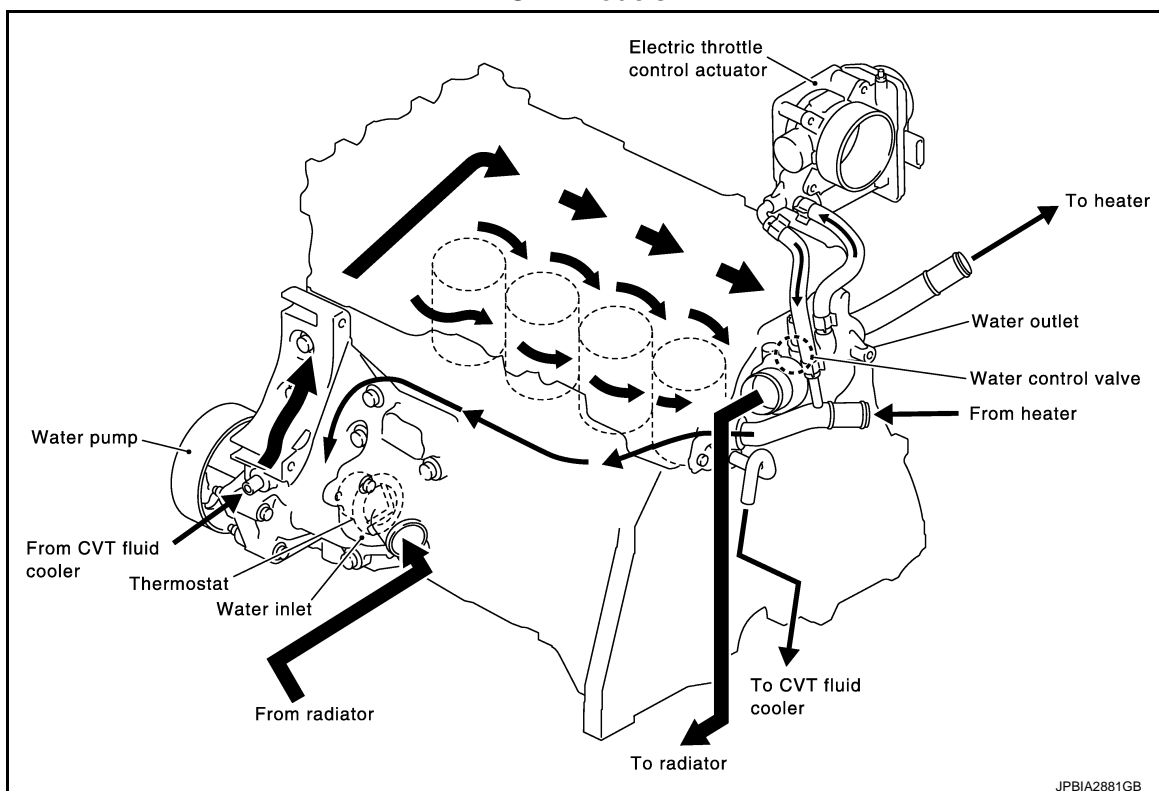

DESCRIPTION

< SYSTEM DESCRIPTION >

Engine Cooling System Schematic

INFOID:000000009950389

A

CO

C

D

E

F

G

H

I

J

K

L

M

N

O

P

M/T models

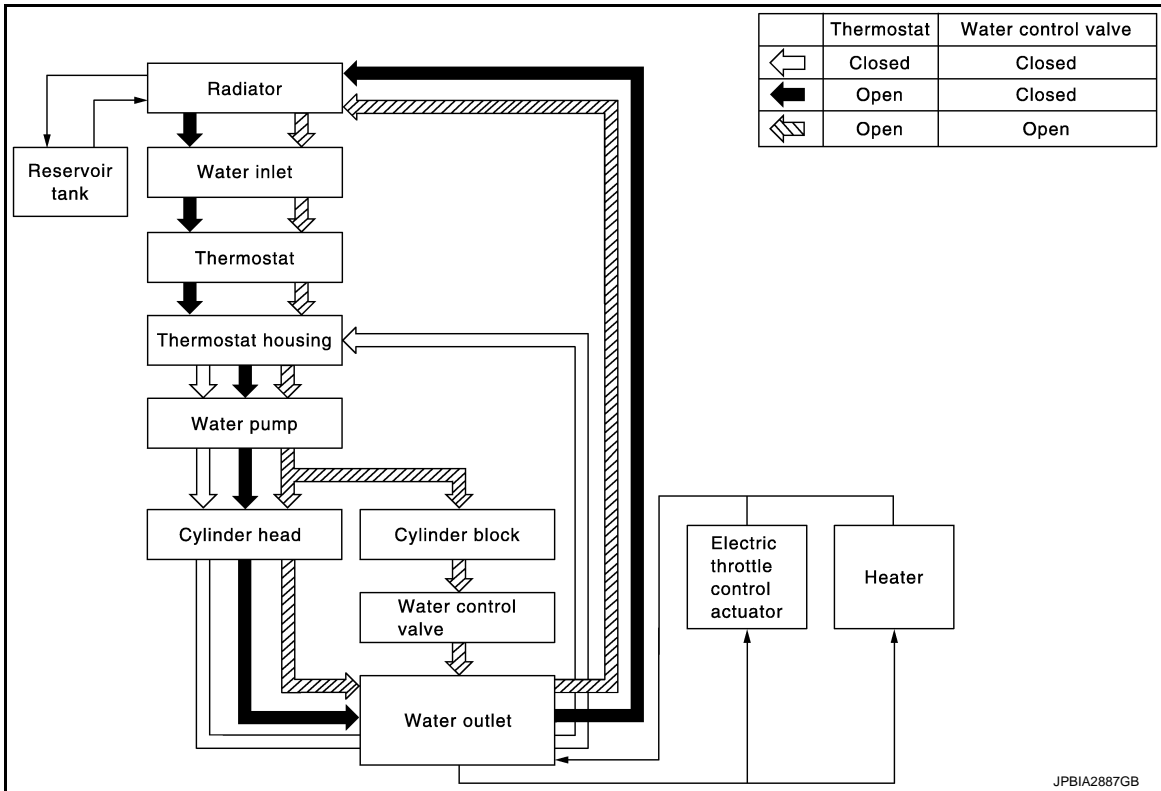

CVT models

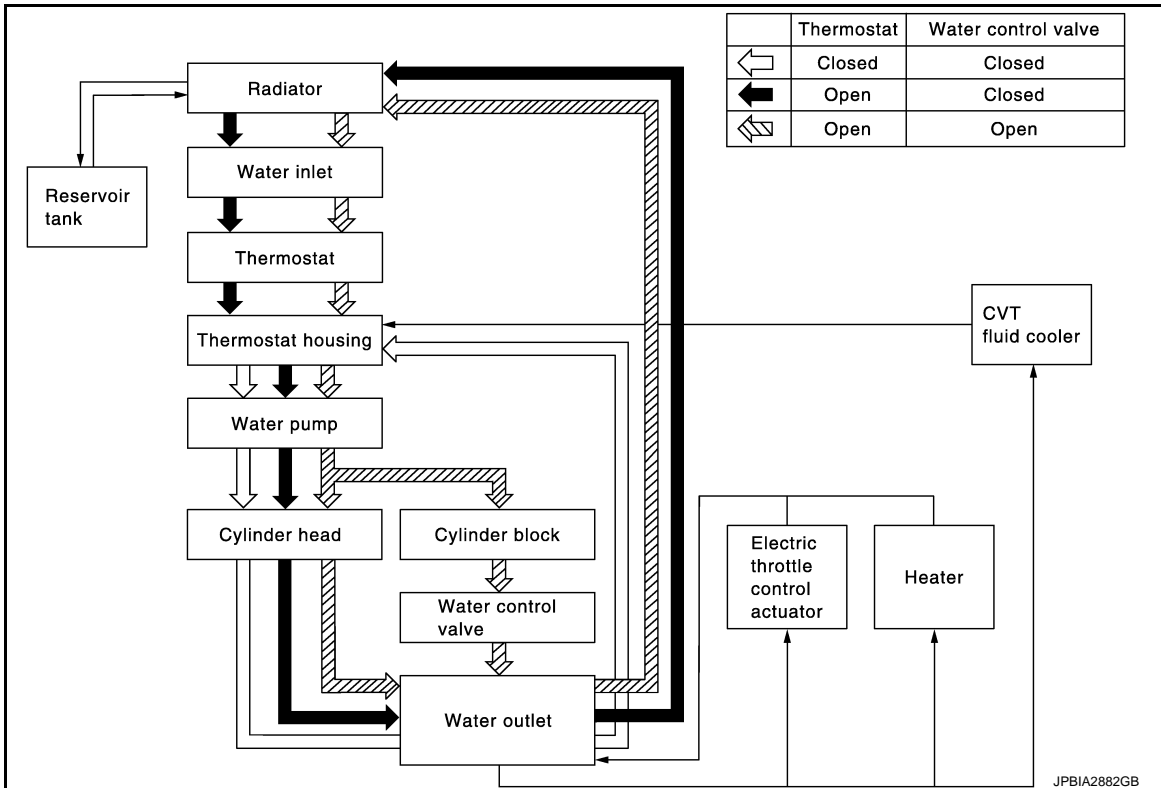

OVERHEATING CAUSE ANALYSIS

< SYMPTOM DIAGNOSIS >

SYMPTOM DIAGNOSIS

OVERHEATING CAUSE ANALYSIS

Troubleshooting Chart

INFOID:000000009950390

		Symptom	Check items		
Cooling system parts malfunction	Poor heat transfer	Water pump malfunction	Worn or loose drive belt	—	
		Thermostat and water control valve stuck closed	—		
		Damaged fins	Dust contamination or paper clogging		
			Physical damage		
		Clogged radiator cooling tube	Excess foreign material (rust, dirt, sand, etc.)		
	Reduced air flow	Cooling fan does not operate	Fan assembly	—	
		High resistance to fan rotation			
		Damaged fan blades			
		Damaged radiator shroud	—	—	
		Improper engine coolant mixture ratio	—	—	
		Poor engine coolant quality	—	Engine coolant viscosity	—
	Insufficient engine coolant	Engine coolant leakage	Cooling hose	Loose clamp	
				Cracked hose	
			Water pump	Poor sealing	
			Radiator cap	Loose	
Poor sealing					
Radiator		O-ring for damage, deterioration or improper fitting			
		Cracked radiator tank			
		Cracked radiator core			
	Reservoir tank	Cracked reservoir tank			
Overflowing reservoir tank	Exhaust gas leakage into cooling system	Cylinder head deterioration			
		Cylinder head gasket deterioration			

OVERHEATING CAUSE ANALYSIS

< SYMPTOM DIAGNOSIS >

	Symptom		Check items			
Except cooling system parts malfunction	—	Overload on engine	Abusive driving	High engine rpm under no load	A	
				Driving in low gear for extended time	CO	
				Driving at extremely high speed		
				Power train system malfunction		C
				Installed improper size wheels and tires	—	D
				Dragging brakes		
			Improper ignition timing		E	
	Blocked or restricted air flow	Blocked bumper	—			E
		Blocked radiator grille	Installed car brassiere			F
			Mud contamination or paper clogging		—	
		Blocked radiator	—			
		Blocked condenser				G
	Installed large fog lamp	Blocked air flow				

A
CO
C
D
E
F
G
H
I
J
K
L
M
N
O
P

PRECAUTIONS

< PRECAUTION >

PRECAUTION

PRECAUTIONS

Precautions for Removing of Battery Terminal

INFOID:000000010191330

- When removing the 12V battery terminal, turn OFF the ignition switch and wait at least 30 seconds.

NOTE:

ECU may be active for several tens of seconds after the ignition switch is turned OFF. If the battery terminal is removed before ECU stops, then a DTC detection error or ECU data corruption may occur.

- For vehicles with the 2-batteries, be sure to connect the main battery and the sub battery before turning ON the ignition switch.

NOTE:

If the ignition switch is turned ON with any one of the terminals of main battery and sub battery disconnected, then DTC may be detected.

- After installing the 12V battery, always check "Self Diagnosis Result" of all ECUs and erase DTC.

NOTE:

The removal of 12V battery may cause a DTC detection error.

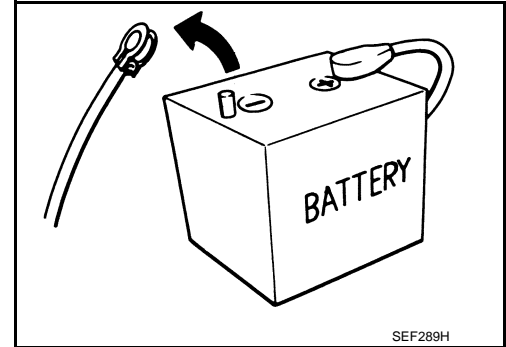

Precaution for Supplemental Restraint System (SRS) "AIR BAG" and "SEAT BELT PRE-TENSIONER"

INFOID:000000010191331

The Supplemental Restraint System such as "AIR BAG" and "SEAT BELT PRE-TENSIONER", used along with a front seat belt, helps to reduce the risk or severity of injury to the driver and front passenger for certain types of collision. This system includes seat belt switch inputs and dual stage front air bag modules. The SRS system uses the seat belt switches to determine the front air bag deployment, and may only deploy one front air bag, depending on the severity of a collision and whether the front occupants are belted or unbelted. Information necessary to service the system safely is included in the "SRS AIR BAG" and "SEAT BELT" of this Service Manual.

WARNING:

Always observe the following items for preventing accidental activation.

- To avoid rendering the SRS inoperative, which could increase the risk of personal injury or death in the event of a collision that would result in air bag inflation, all maintenance must be performed by an authorized NISSAN/INFINITI dealer.
- Improper maintenance, including incorrect removal and installation of the SRS, can lead to personal injury caused by unintentional activation of the system. For removal of Spiral Cable and Air Bag Module, see "SRS AIR BAG".
- Never use electrical test equipment on any circuit related to the SRS unless instructed to in this Service Manual. SRS wiring harnesses can be identified by yellow and/or orange harnesses or harness connectors.

PRECAUTIONS WHEN USING POWER TOOLS (AIR OR ELECTRIC) AND HAMMERS

WARNING:

Always observe the following items for preventing accidental activation.

- When working near the Air Bag Diagnosis Sensor Unit or other Air Bag System sensors with the ignition ON or engine running, never use air or electric power tools or strike near the sensor(s) with a hammer. Heavy vibration could activate the sensor(s) and deploy the air bag(s), possibly causing serious injury.
- When using air or electric power tools or hammers, always switch the ignition OFF, disconnect the battery, and wait at least 3 minutes before performing any service.

PREPARATION

< PREPARATION >

PREPARATION

PREPARATION

Commercial Service Tools

INFOID:000000009950393

A

CO

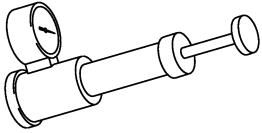
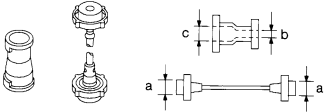
Tool name	Description
<p>Radiator cap tester</p>  <p>PBIC1982E</p>	<p>Checking radiator and radiator cap</p>
<p>Radiator cap tester adapter</p>  <p>S-NT564</p>	<p>Adapting radiator cap tester to radiator cap and radiator filler neck</p> <p>a: 28 (1.10) dia. b: 31.4 (1.236) dia. c: 41.3 (1.626) dia. Unit: mm (in)</p>

C

D

E

F

G

H

I

J

K

L

M

N

O

P

ENGINE COOLANT

< PERIODIC MAINTENANCE >

PERIODIC MAINTENANCE

ENGINE COOLANT

Inspection

INFOID:000000009950394

LEVEL

- Check that the reservoir tank engine coolant level is within the "MIN" to "MAX" when the engine is cool.

A : MAX

B : MIN

- Adjust the engine coolant level if necessary.

CAUTION:

Refill Genuine NISSAN Long Life Antifreeze/Coolant (blue) or equivalent in its quality mixed with water (distilled or demineralized). Refer to [MA-10, "Fluids and Lubricants"](#).

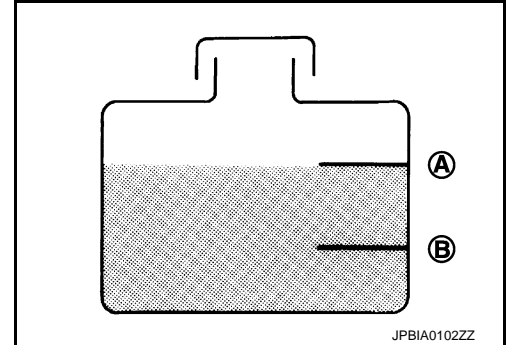

LEAKAGE

- To check for leakage, apply pressure to the cooling system with the radiator cap tester (commercial service tool) (A) and the radiator cap tester adapter (commercial service tool) (B).

Testing pressure: Refer to [CO-25, "Radiator"](#).

WARNING:

Never remove radiator cap when engine is hot. Serious burns may occur from high-pressure engine coolant escaping from engine cooling system.

CAUTION:

Higher test pressure than specified may cause radiator damage.

NOTE:

In a case that engine coolant decreases, replenish radiator with engine coolant.

- If anything is found, repair or replace damaged parts.

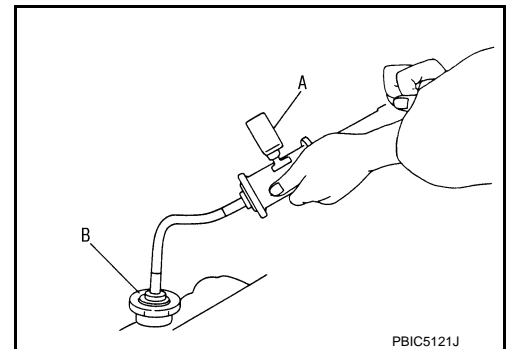

Draining

INFOID:000000009950395

WARNING:

- Never remove radiator cap when engine is hot. Serious burns may occur from high-pressure engine coolant escaping from radiator.
- Wrap a thick cloth around the radiator cap. Slowly turn it a quarter of a turn to release built-up pressure. Then turn it all the way.

1. Remove engine under cover.
2. Open radiator drain plug (A) at the bottom of radiator, and then remove radiator cap.

← : Vehicle front

CAUTION:

Perform this step when engine is cold.

- When draining all of engine coolant in the system, open water drain plugs on cylinder block. Refer to [EM-87, "Disassembly and Assembly"](#).

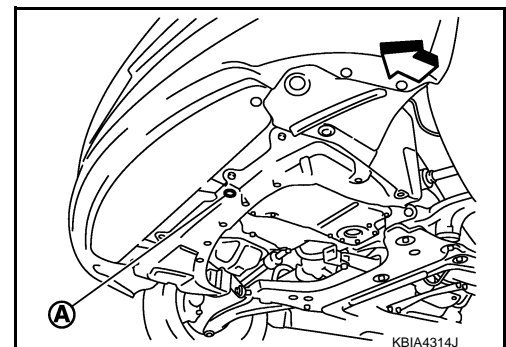

3. Remove reservoir tank if necessary, and drain engine coolant and clean reservoir tank before installing. Refer to [CO-14, "Exploded View"](#).

ENGINE COOLANT

< PERIODIC MAINTENANCE >

4. Check drained engine coolant for contaminants such as rust, corrosion or discoloration. If contaminated, flush the engine cooling system. Refer to [CO-10, "Flushing"](#).

Refilling

INFOID:000000009950396

CAUTION:

- Do not reuse O-rings.
- Do not put additive such as waterleak preventive, since it may cause cooling waterway clogging.
- When refilling use Genuine NISSAN Long Life Antifreeze/Coolant (blue) or equivalent in its quality mixed with water (distilled or demineralized). Refer to [MA-10, "Fluids and Lubricants"](#).

1. Install reservoir tank if removed and radiator drain plug.

CAUTION:

Be sure to clean drain plug and install with new O-ring.

Radiator drain plug : Refer to [CO-14, "Exploded View"](#).

- If water drain plugs on cylinder block are removed, close and tighten them. Refer to [EM-87, "Disassembly and Assembly"](#).
2. Check that each hose clamp has been firmly tightened.
 3. Remove air duct (between air cleaner case and electric throttle control actuator). Refer to [EM-24, "Exploded View"](#).
 4. Disconnect heater hose (1) at position (←) in the figure.

← : Vehicle front

- Enhance heater hose as high as possible.

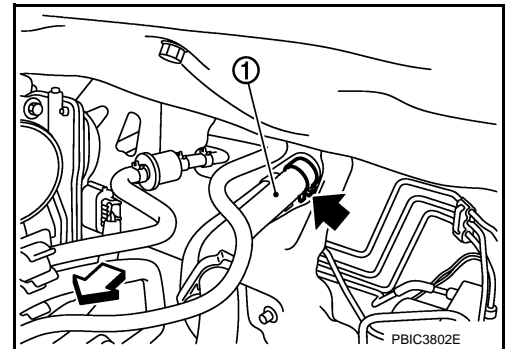

5. Fill radiator (1) to specified level.

CAUTION:

Never adhere the engine coolant to electronic equipments (alternator etc.).

- Pour coolant slowly of less than 2 ℓ (2-1/8 US qt, 1-3/4 Imp qt) a minute to allow air in system to escape.
- When engine coolant overflows disconnected heater hose, connect heater hose, and continue filling the engine cooling system.

Engine coolant capacity

(With reservoir tank at "MAX" level)

Refer to [CO-25, "Periodical Maintenance Specification"](#).

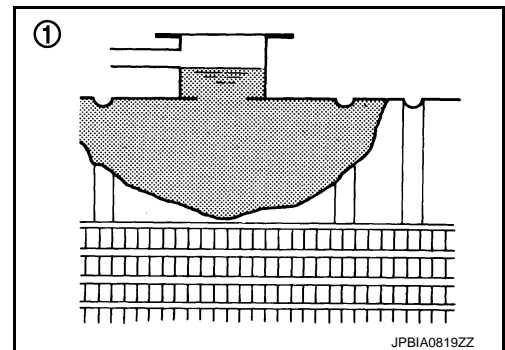

6. Refill reservoir tank to "MAX" level line with engine coolant.

A : MAX

B : MIN

Reservoir tank engine coolant capacity
(At "MAX" level)

Refer to [CO-25, "Periodical Maintenance Specification"](#).

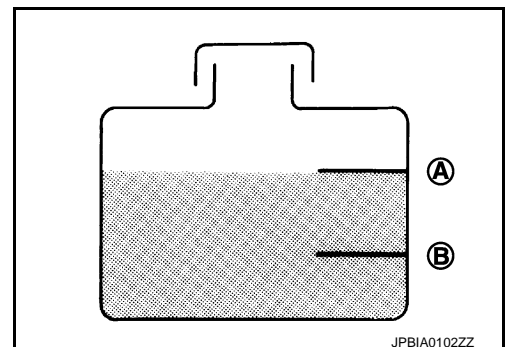

ENGINE COOLANT

< PERIODIC MAINTENANCE >

7. Install air duct (between air cleaner case and electric throttle control actuator). Refer to [EM-24. "Exploded View"](#).
8. Install radiator cap.
9. Warm up engine until opening thermostat. Standard for warming-up time is approximately 10 minutes at 3,000 rpm.
 - Check thermostat opening condition by touching radiator hose (lower) to see a flow of warm water.**CAUTION:**
Watch water temperature gauge so as not to overheat engine.
10. Stop the engine and cool down to less than approximately 50°C (122°F).
 - Cool down using fan to reduce the time.
 - If necessary, refill radiator up to filler neck with engine coolant.**CAUTION:**
Never adhere the engine coolant to electronic equipments (alternator etc.).
11. Refill reservoir tank to "MAX" level line with engine coolant.
12. Repeat steps 5 through 10 two or more times with radiator cap installed until engine coolant level no longer drops.
13. Check cooling system for leakage with engine running.
14. Warm up the engine, and check for sound of engine coolant flow while running engine from idle up to 3,000 rpm with heater temperature controller set at several position between "COOL" and "WARM".
 - Sound may be noticeable at heater unit.
15. Repeat step 14 three times.
16. If sound is heard, bleed air from cooling system by repeating step 5 through 10 until reservoir tank level no longer drops.

Flushing

INFOID:000000009950397

1. Install reservoir tank if removed and radiator drain plug.
CAUTION:
Be sure to clean drain plug and install with new O-ring.

Radiator drain plug : Refer to [CO-14. "Exploded View"](#).

- If water drain plugs on cylinder block are removed, close and tighten them. Refer to [EM-87. "Disassembly and Assembly"](#).
2. Remove air duct (between air cleaner case and electric throttle control actuator). Refer to [EM-24. "Exploded View"](#).
 3. Disconnect heater hose (1) at position (↔) in the figure.

↔ : Vehicle front

- Enhance heater as high as possible.

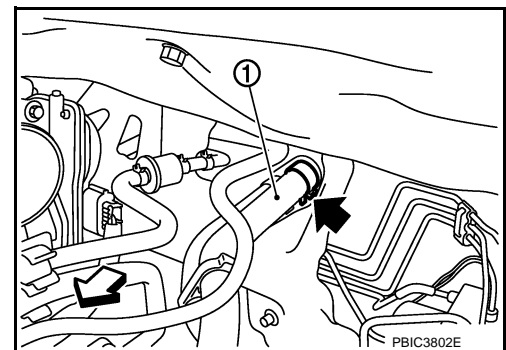

4. Fill radiator and reservoir tank with water and reinstall radiator cap.
 - When engine coolant over flows disconnected heater hose, connect heater hose, and continue filling the engine coolant.
5. Install air duct (between air cleaner case and electric throttle control actuator). Refer to [EM-24. "Exploded View"](#).
6. Run the engine and warm it up to normal operating temperature.
7. Rev the engine two or three times under no-load.
8. Stop the engine and wait until it cools down.
9. Drain water from the system. Refer to [CO-8. "Draining"](#).

ENGINE COOLANT

< PERIODIC MAINTENANCE >

10. Repeat steps 1 through 9 until clear water begins to drain from radiator.

A

CO

C

D

E

F

G

H

I

J

K

L

M

N

O

P

RADIATOR

< PERIODIC MAINTENANCE >

RADIATOR

RADIATOR CAP

RADIATOR CAP : Inspection

INFOID:000000009950398

- Check valve seat (A) of radiator cap.

B : Metal plunger

- Check that valve seat is swollen to the extent that the edge of the plunger cannot be seen when watching it vertically from the top.
- Check that valve seat has no soil and damage.

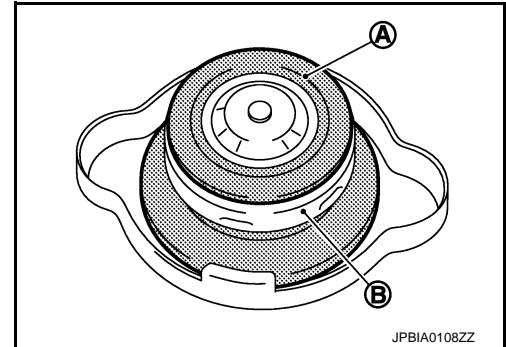

- Pull negative-pressure valve to open it, and that it close completely when released.
- Check that there is no dirt or damage on the valve seat of radiator cap negative-pressure valve.
- Check that there are no unusualness in the opening and closing conditions of negative-pressure valve.

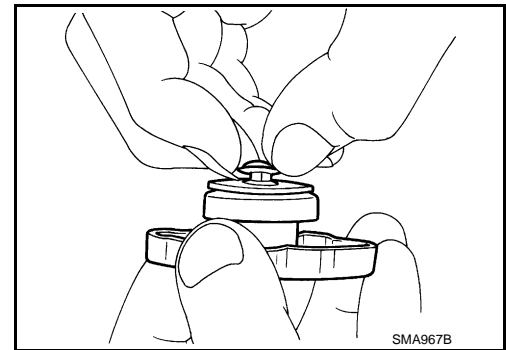

- Check radiator cap relief pressure.

Standard and Limit : Refer to [CO-25, "Radiator"](#).

- When connecting radiator cap to the radiator cap tester (commercial service tool) (A) and the radiator cap tester adapter (commercial service tool) (B), apply engine coolant to the cap seal surface.

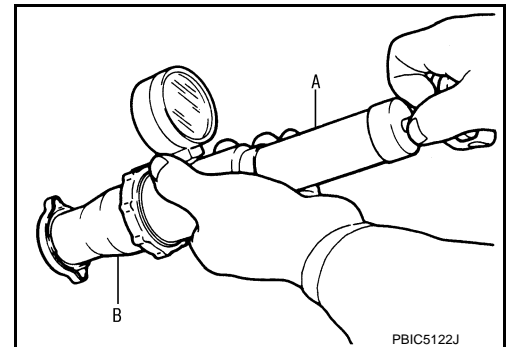

- Replace radiator cap if there is an unusualness related to the above three.

CAUTION:

When installing radiator cap, thoroughly wipe out the radiator filler neck to remove any waxy residue or foreign material.

RADIATOR

RADIATOR : Inspection

INFOID:000000009950399

Check radiator for mud or clogging. If necessary, clean radiator as follows.

CAUTION:

- **Be careful not to bend or damage radiator fins.**
 - **When radiator is cleaned without removal, remove all surrounding parts such as radiator cooling fan assembly and horns. Then tape harness and harness connectors to prevent water from entering.**
1. Apply water by hose to the back side of the radiator core vertically downward.
 2. Apply water again to all radiator core surfaces once per minute.
 3. Stop washing if any stains no longer flow out from radiator.

RADIATOR

< PERIODIC MAINTENANCE >

4. Blow air into the back side of radiator core vertically downward.
 - Use compressed air lower than 490 kPa (5 kg/cm², 71 psi) and keep distance more than 30 cm (11.81 in).
5. Blow air again into all the radiator core surfaces once per minute until no water sprays out.

A

CO

C

D

E

F

G

H

I

J

K

L

M

N

O

P

RADIATOR

< REMOVAL AND INSTALLATION >

REMOVAL AND INSTALLATION

RADIATOR

Exploded View

INFOID:000000009950400

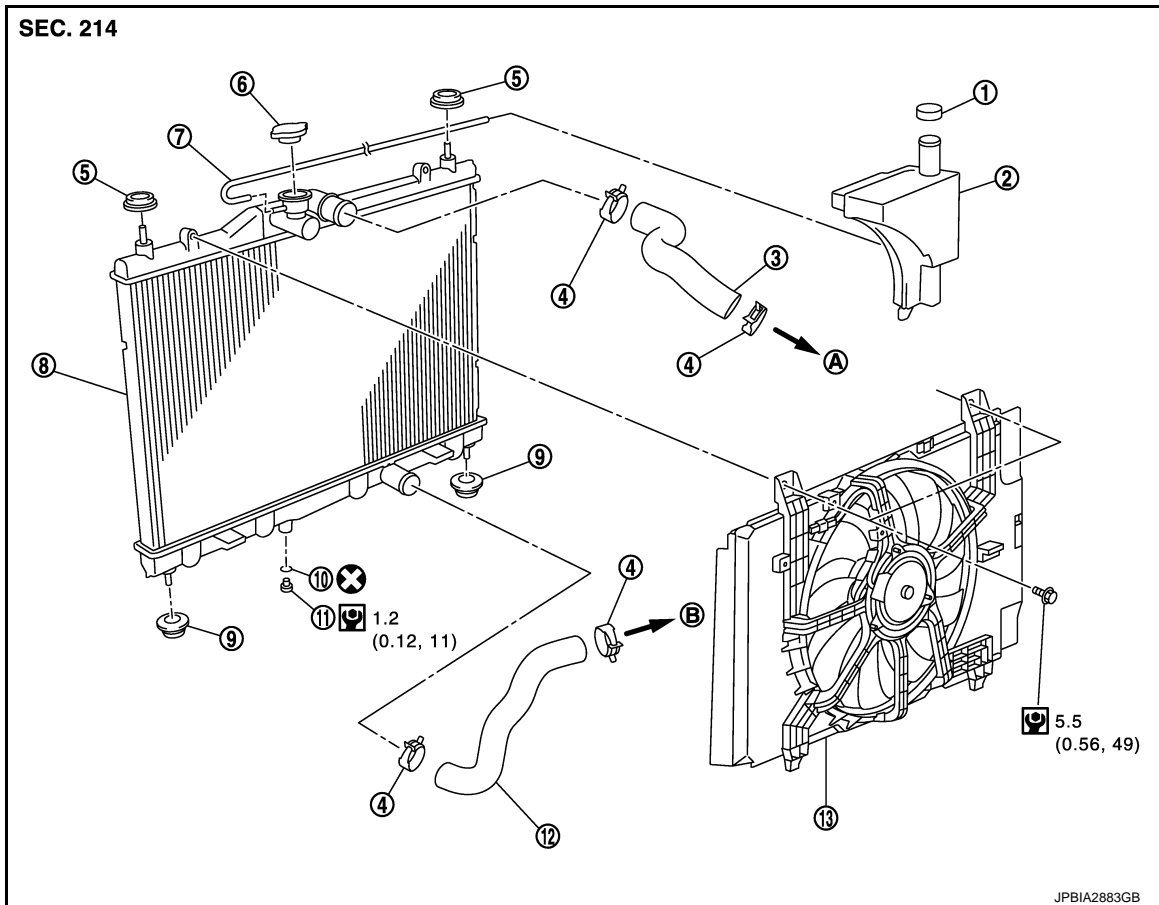

JPBIA2883GB

- | | | |
|--------------------------|----------------------------|----------------------------|
| 1. Reservoir tank cap | 2. Reservoir tank | 3. Radiator hose (upper) |
| 4. Clamp | 5. Mounting rubber (upper) | 6. Radiator cap |
| 7. Reservoir tank hose | 8. Radiator | 9. Mounting rubber (lower) |
| 10. O-ring | 11. Drain plug | 12. Radiator hose (lower) |
| 13. Cooling fan assembly | | |
- A. To water outlet B. To water inlet

⊗ : Always replace after every disassembly.

⊙ : N·m (kg-m, in-lb)

Removal and Installation

INFOID:000000009950401

REMOVAL

WARNING:

- Never remove radiator cap when engine is hot. Serious burns may occur from high-pressure engine coolant escaping from engine cooling system.
- Wrap a thick cloth around the radiator cap. Slowly turn it a quarter of a turn to release built-up pressure. Then turn it all the way.

NOTE:

When removing components such as hoses, tubes/lines, etc., cap or plug openings to prevent fluid from spilling.

1. Drain engine coolant from radiator. Refer to [CO-8. "Draining"](#).

RADIATOR

< REMOVAL AND INSTALLATION >

CAUTION:

- Perform this step when the engine is cold.
- Never spill engine coolant on drive belt.

2. Remove air duct (inlet) and resonator assembly. Refer to [EM-24, "Exploded View"](#).
3. Remove reservoir tank as follows:
 - a. Disconnect reservoir tank hose.
 - b. Release the tab (A) in the direction shown by the arrow (←).
 - c. Lift up and remove the reservoir tank with tab released.

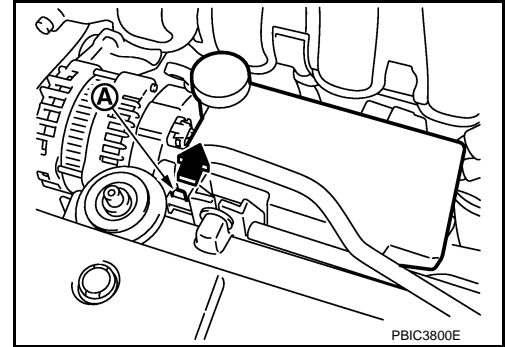

4. Remove radiator hose (upper and lower).
5. Disconnect harness connector from fan motor, and move harness aside.
6. Remove cooling fan assembly.

CAUTION:

Be careful not to damage or scratch the radiator core.

7. Remove the following parts:
 - Front grille assembly: Refer to [EXT-17, "Exploded View"](#).
 - Front bumper fascia assembly: Refer to [EXT-11, "Exploded View"](#).
 - Front combination lamp assembly (RH and LH): Refer to [EXL-191, "Exploded View"](#).
8. Remove radiator core support (upper). Refer to [DLK-186, "Exploded View"](#) (WITH INTELLIGENT KEY STSTEM) or [DLK-339, "Exploded View"](#) (WITHOUT INTELLIGENT KEY STSTEM).
9. Pull up and remove the radiator assembly (1).

2 : Condenser assembly

← : Vehicle front

CAUTION:

Be careful not to damage radiator core and condenser assembly core.

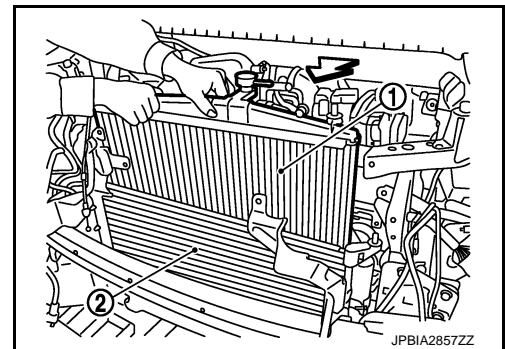

INSTALLATION

CAUTION:

Do not reuse O-rings.

Note the following, and install in the reverse order of removal.

NOTE:

- Insert the radiator hose (1) all the way to the stopper (2) or by 33 mm (1.30 in) (hose without a stopper).

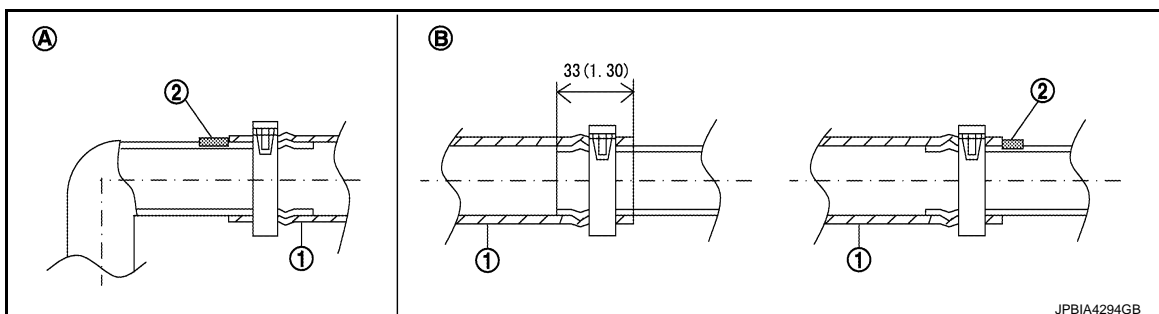

RADIATOR

< REMOVAL AND INSTALLATION >

Unit mm (in)

A. Radiator side

B. Engine side

- For the orientation of the hose clamp pawl, refer to the figure.

Radiator hose	Hose end	Paint mark	Position of hose clamp*
Radiator hose (upper)	Radiator side	Upper	A
	Engine side	Upper	B
Radiator hose (lower)	Radiator side	Lower	C
	Engine side	Upper	D

*Refer to the illustrations for the specific position each hose clamp tab.

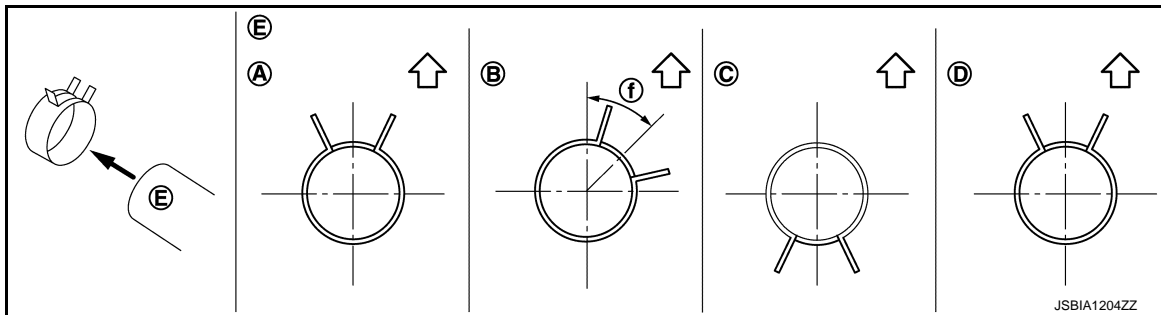

E. View E

f. 45°

↖ : Vehicle upper

- The angle (b) created by the hose clamp pawl and the specified line (A) must be within $\pm 30^\circ$ as shown in the figure.

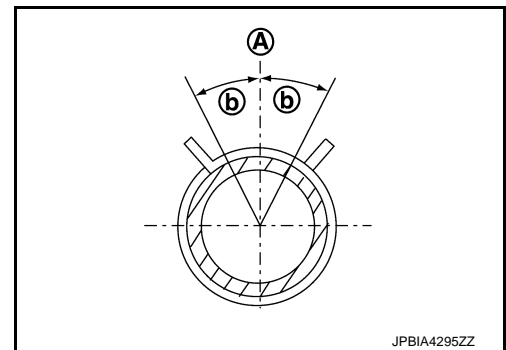

- To install hose clamps (1), check that the dimension (A) from the end of the paint mark (2) on the radiator hose to the hose clamp is within the reference value.

Dimension "A"

3 mm (0.12 in)

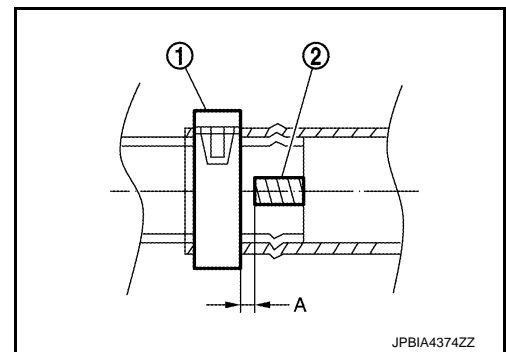

Inspection

INFOID:000000009950402

INSPECTION AFTER INSTALLATION

- Check for leakage of engine coolant using the radiator cap tester adapter (commercial service tool) and the radiator cap tester (commercial service tool). Refer to [CO-8. "Inspection"](#).
- Start and warm up the engine. Check visually that there is no leakage of engine coolant.

COOLING FAN

< REMOVAL AND INSTALLATION >

COOLING FAN

Exploded View

INFOID:000000009950403

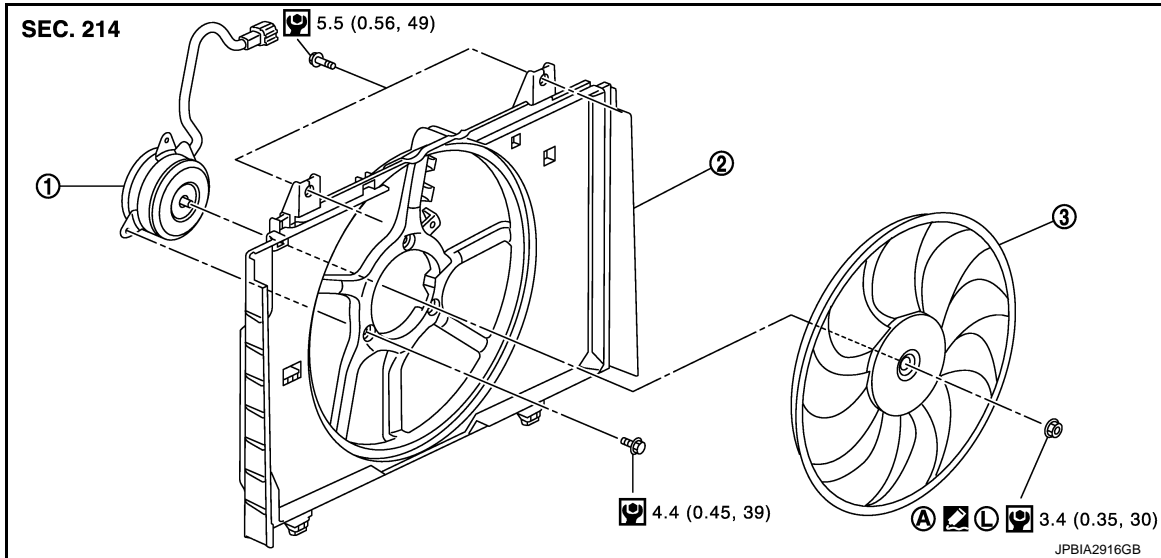

1. Fan motor
 2. Fan shroud
 3. Cooling fan

A. Apply on fan motor shaft

: Apply genuine high strength thread locking sealant or equivalent.

: N-m (kg-m, in-lb)

Removal and Installation

INFOID:000000009950404

REMOVAL

1. Drain engine coolant from radiator. Refer to [CO-8, "Draining"](#).

CAUTION:

- Perform this step engine is cold.
- Never spill engine coolant on drive belt.

2. Remove air duct (inlet) and resonator assembly. Refer to [EM-24, "Exploded View"](#).
3. Remove reservoir tank as follows:
 - a. Disconnect reservoir tank hose.
 - b. Release the tab (A) in the direction shown by the arrow ().
 - c. Lift up and remove the reservoir tank with the tab released.

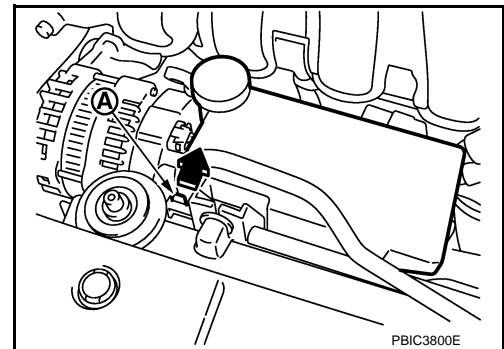

4. Remove radiator hose (upper). Refer to [CO-14, "Exploded View"](#).
5. Disconnect harness connector from fan motor, and move harness to aside.
6. Remove cooling fan assembly.

CAUTION:

COOLING FAN

< REMOVAL AND INSTALLATION >

Be careful not to damage or scratch on radiator core when removing.

INSTALLATION

Note the following, and install in the reverse order of removal.

CAUTION:

Only use genuine parts for fan shroud mounting bolt and observe the specified torque (to prevent radiator from being damaged).

NOTE:

Cooling fan is controlled by ECM. For details, refer to [EC-74. "System Diagram"](#).

Disassembly and Assembly

INFOID:000000009950405

DISASSEMBLY

1. Remove cooling fan mounting nut, and then remove the cooling fan.
2. Remove fan motor.

ASSEMBLY

Note the following, and assemble in the reverse order of disassembly.

- Apply genuine high strength thread locking sealant on fan motor shaft.

Inspection

INFOID:000000009950406

INSPECTION AFTER DISASSEMBLY

Cooling Fan

Inspect cooling fan for crack or unusual bend.

- If anything is found, replace cooling fan.

WATER PUMP

< REMOVAL AND INSTALLATION >

WATER PUMP

Exploded View

INFOID:000000009950407

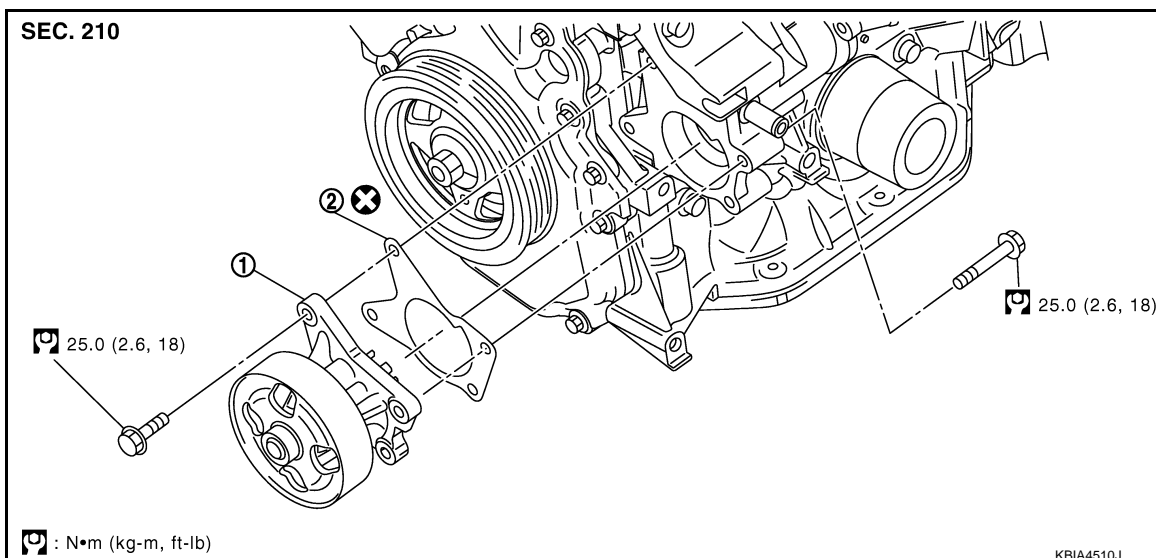

- 1. Water pump
- 2. Gasket

⊗ : Always replace after every disassembly.

Removal and Installation

INFOID:000000009950408

REMOVAL

1. Drain engine coolant from radiator. Refer to [CO-8, "Draining"](#).
CAUTION:
 - Perform this step when the engine is cold.
 - Never spill engine coolant on drive belt.
2. Remove front fender protector (RH). Refer to [EXT-21, "FENDER PROTECTOR : Exploded View"](#).
3. Remove drive belt. Refer to [EM-13, "Removal and Installation"](#).
4. Remove water pump.
 - Engine coolant leakage from cylinder block, so have a receptacle ready below.**CAUTION:**
 - Handle water pump vane so that it does not contact any other parts.
 - Water pump cannot be disassembled and should be replaced as a unit.

INSTALLATION

Install in the reverse order of removal.

Inspection

INFOID:000000009950409

INSPECTION AFTER REMOVAL

- Check visually that there is no significant dirt or rusting on water pump body and vane (A).
- Check that there is no looseness in vane shaft, and that it turns smoothly when rotated by hand.
- Replace water pump, if necessary.

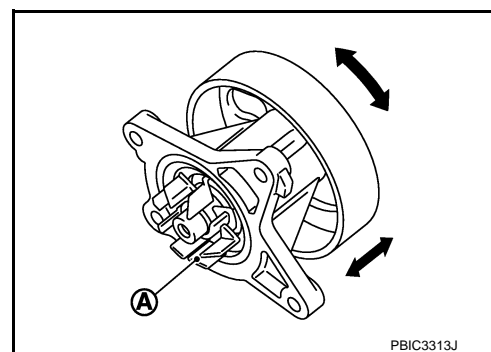

WATER PUMP

< REMOVAL AND INSTALLATION >

INSPECTION AFTER INSTALLATION

- Check for leakage of engine coolant using the radiator cap tester adapter (commercial service tool) and the radiator cap tester (commercial service tool). Refer to [CO-8, "Inspection"](#).
- Start and warm up the engine. Check visually that there is no leakage of engine coolant.

THERMOSTAT

< REMOVAL AND INSTALLATION >

THERMOSTAT

Exploded View

INFOID:000000009950410

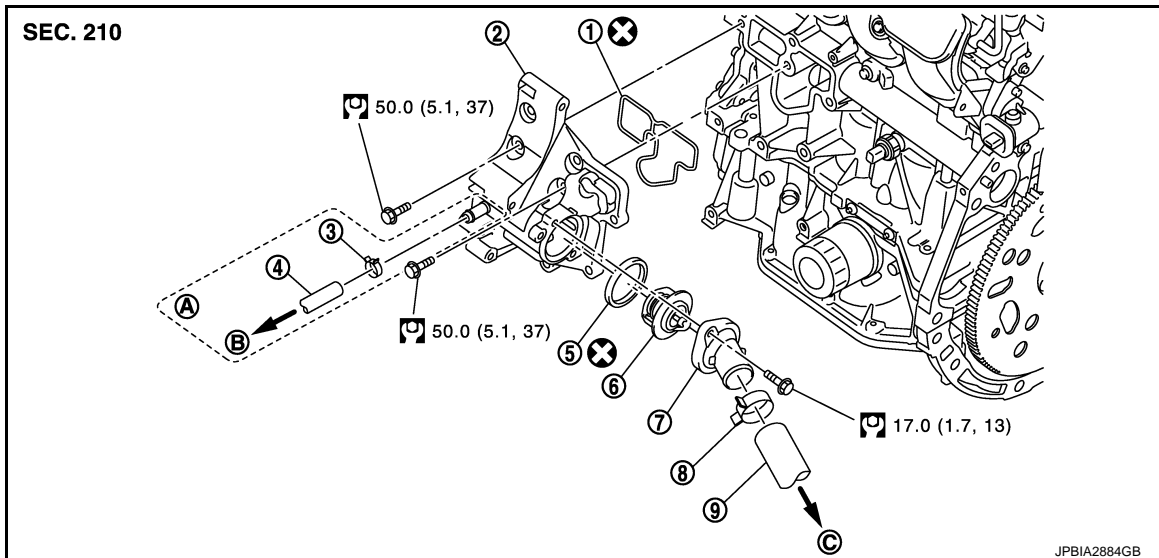

- | | | |
|----------------|------------------------|--------------------------|
| 1. Gasket | 2. Thermostat housing | 3. Clamp |
| 4. Water hose | 5. Rubber ring | 6. Thermostat |
| 7. Water inlet | 8. Clamp | 9. Radiator hose (lower) |
| A. CVT models | B. To CVT fluid cooler | C. To radiator |

⊗ : Always replace after every disassembly.

Ⓜ : N·m (kg·m, ft·lb)

Removal and Installation

INFOID:000000009950411

REMOVAL

1. Drain engine coolant from radiator. Refer to [CO-8. "Draining"](#).
CAUTION:
Perform this step when engine is cold.
2. Remove air duct (inlet) and resonator assembly. Refer to [EM-24. "Exploded View"](#).
3. Add paint mark, then disconnect radiator hose (lower) from water inlet. Refer to [CO-14. "Exploded View"](#).
4. Remove water inlet and thermostat.
 - Engine coolant leakage from cylinder block, so have a receptacle ready below.
5. Remove thermostat housing with the following procedure:
 - a. Remove A/C compressor with A/C piping connected, and temporarily fasten it on vehicle with a rope. Refer to [HA-31. "Exploded View"](#).
 - b. Remove water pump. Refer to [CO-19. "Exploded View"](#).
 - c. Remove alternator. Refer to [CHG-30. "Exploded View"](#).

INSTALLATION

Note the following, and install in the reverse order of removal.

Thermostat

THERMOSTAT

< REMOVAL AND INSTALLATION >

- Install thermostat with making rubber ring (1) groove fit to thermostat flange (A) with the whole circumference.

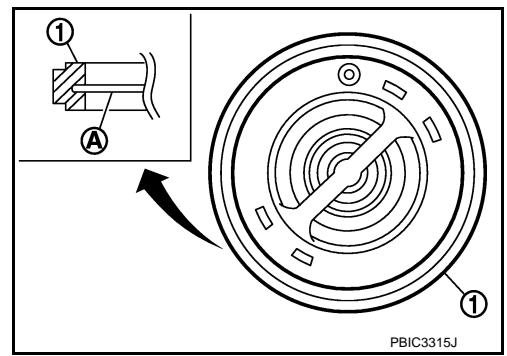

- Install thermostat (1) with jiggle valve (A) facing upwards.

2 : Thermostat housing

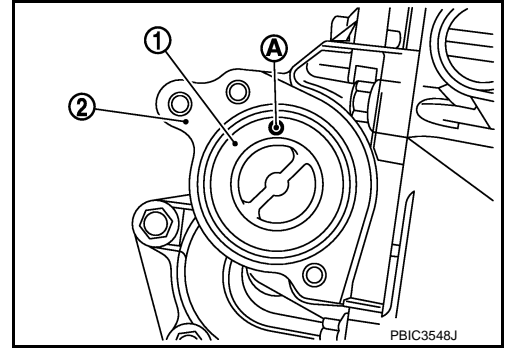

Inspection

INFOID:000000009950412

INSPECTION AFTER REMOVAL

Thermostat

- Place a thread (A) so that it is caught in the valves of thermostat (1). Immerse fully in a container (B) filled with water. Heat while stirring.
- The valve opening temperature is the temperature at which the valve opens and falls from the thread.
- Continue heating. Check the full open valve lift amount.
- After checking the maximum valve lift amount, lower the water temperature and check the valve closing temperature.

Standard: Refer to [CO-25. "Thermostat"](#).

- If out of the standard, replace thermostat.

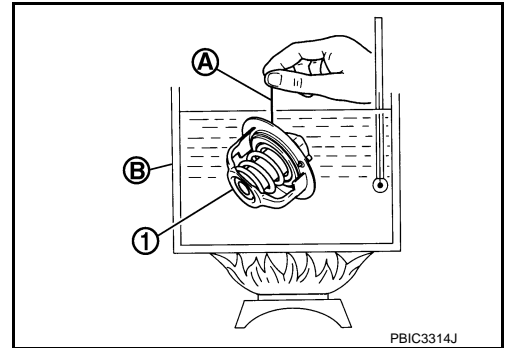

INSPECTION AFTER INSTALLATION

- Check for leakage of engine coolant using the radiator cap tester adapter (commercial service tool) and the radiator cap tester (commercial service tool). Refer to [CO-8. "Inspection"](#).
- Start and warm up the engine. Check visually that there is no leakage of engine coolant.

WATER OUTLET

< REMOVAL AND INSTALLATION >

WATER OUTLET

Exploded View

INFOID:000000009950413

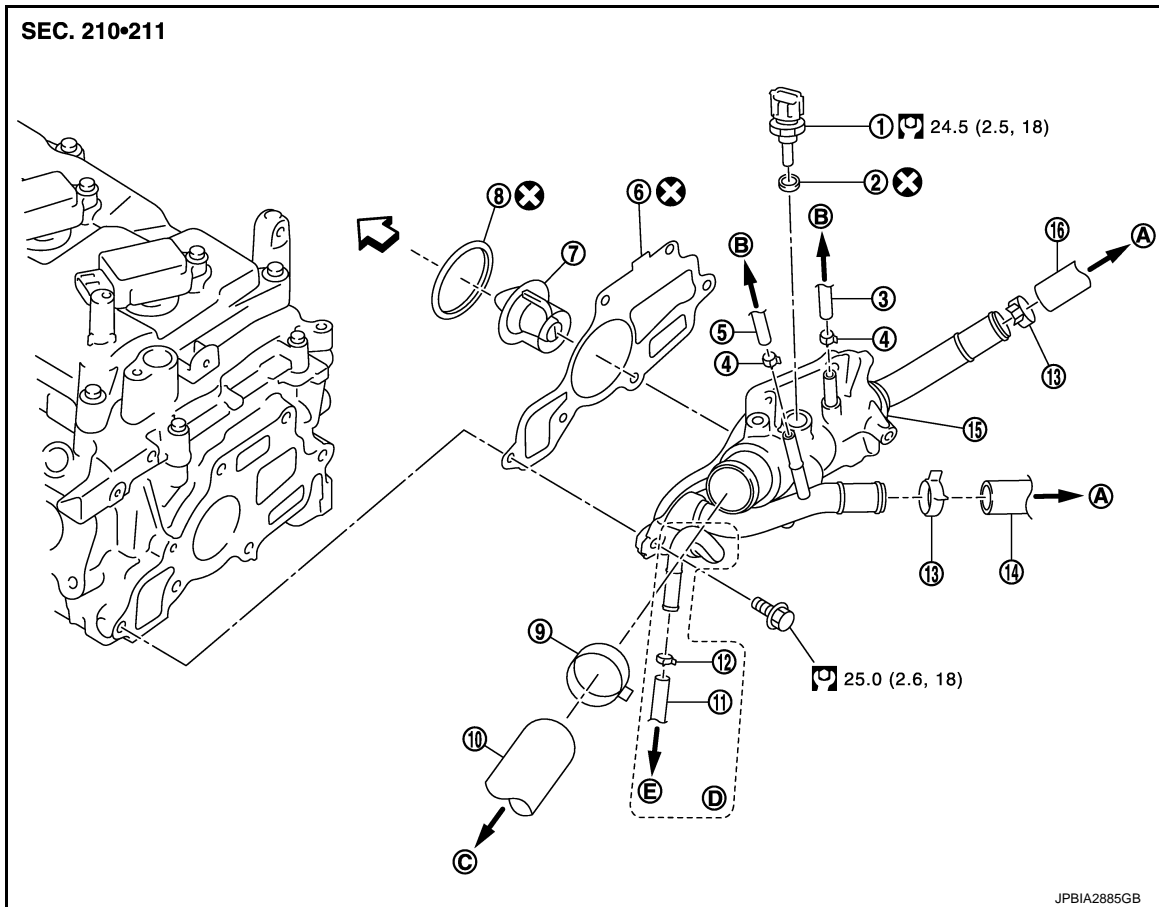

- | | | |
|--------------------------------------|-----------------|------------------|
| 1. Engine coolant temperature sensor | 2. Washer | 3. Water hose |
| 4. Clamp | 5. Water hose | 6. Gasket |
| 7. Water control valve | 8. Rubber ring | 9. Clamp |
| 10. Radiator hose (upper) | 11. Water hose | 12. Clamp |
| 13. Clamp | 14. Heater hose | 15. Water outlet |
| 16. Heater hose | | |
- A. To heater
 B. To electric throttle control actuator
 C. To radiator
 D. CVT models
 E. To CVT fluid cooler

↶ : Engine front

⊗ : Always replace after every disassembly.

⊞ : N·m (kg·m, ft·lb)

Removal and Installation

INFOID:000000009950414

REMOVAL

1. Drain engine coolant from radiator. Refer to [CO-8, "Draining"](#).
CAUTION:
 - Perform this step when engine is cold.
 - Never spill engine coolant on drive belt.
2. Remove air duct (inlet) and resonator assembly and each air ducts. Refer to [EM-24, "Exploded View"](#).
3. Disconnect radiator hose (upper). Refer to [CO-14, "Exploded View"](#).

WATER OUTLET

< REMOVAL AND INSTALLATION >

4. Disconnect harness connector from engine coolant temperature sensor.
5. Remove water hoses.
6. Remove heater hoses.
7. Remove water outlet.
8. Remove engine coolant temperature sensor from water outlet, if necessary.

INSTALLATION

Note the following, and install in the reverse order of removal.

- Install water control valve with making rubber ring (1) groove fit to water control valve flange (A) with the whole circumference.

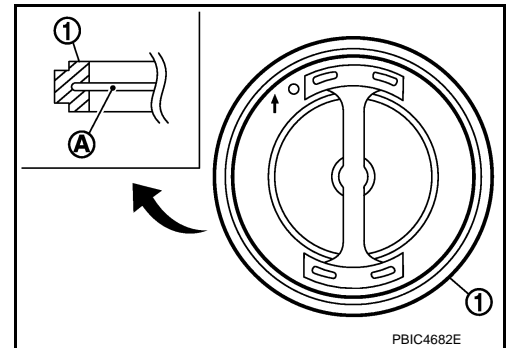

- Install water control valve (2) with the arrow (A) facing up and the frame center part (B) facing upwards.

1 : Water outlet

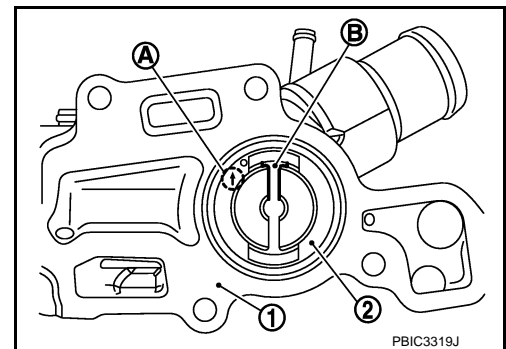

INFOID:000000009950415

Inspection

INSPECTION AFTER REMOVAL

Water Control Valve

- Place a thread (A) so that it is caught in the valves of water control valve (1). Immerse fully in a container (B) filled with water. Heat while stirring.
- The valve opening temperature is the temperature at which the valve opens and falls from the thread.
- Continue heating. Check the continuous valve lifting toward maximum valve lift.

NOTE:

- The maximum valve lift amount standard temperature for water control valve is the reference value.
- After checking the maximum valve lift amount, lower the water temperature and check the valve closing temperature.

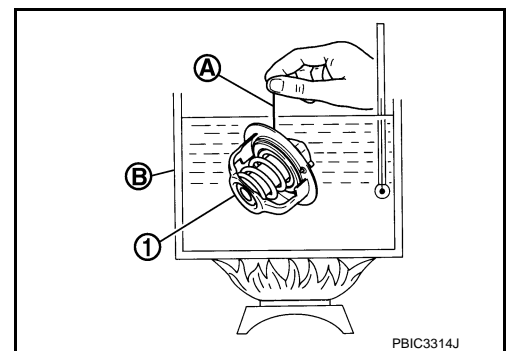

Standard: Refer to [CO-25, "Water Control Valve"](#).

- If out of the standard, replace water control valve.

INSPECTION AFTER INSTALLATION

- Check for leakage of engine coolant using the radiator cap tester adapter (commercial service tool) and the radiator cap tester (commercial service tool). Refer to [CO-8, "Inspection"](#).
- Start and warm up the engine. Check visually that there is no leakage of engine coolant.

SERVICE DATA AND SPECIFICATIONS (SDS)

< SERVICE DATA AND SPECIFICATIONS (SDS)

SERVICE DATA AND SPECIFICATIONS (SDS)

SERVICE DATA AND SPECIFICATIONS (SDS)

Periodical Maintenance Specification

INFOID:000000009950416

ENGINE COOLANT CAPACITY (APPROXIMATE)

Unit: ℓ (US qt, Imp qt)

Engine coolant capacity (With reservoir tank at "MAX" level)	CVT models	7.1 (7-1/2, 6-1/4)
	M/T models	6.8 (7-1/4, 6)
Reservoir tank engine coolant capacity (At "MAX" level)		0.7 (3/4, 5/8)

Radiator

INFOID:000000009950417

Unit: kPa (kg/cm², psi)

Cap relief pressure	Standard	78 - 98 (0.8 - 1.0, 11 - 14)
	Limit	59 (0.6, 9)
Leakage testing pressure		98 (1.0, 14)

Thermostat

INFOID:000000009950418

Standard

Valve opening temperature	80.5 - 83.5°C (177 - 182°F)
Maximum valve lift	8.0 mm/95°C (0.315 in/203°F)
Valve closing temperature	77°C (171°F)

Water Control Valve

INFOID:000000009950419

Standard

Valve opening temperature	93.5 - 96.5°C (200 - 206°F)
Maximum valve lift	8.0 mm/108°C (0.315 in/226°F)
Valve closing temperature	90°C (194°F)

A
CO
C
D
E
F
G
H
I
J
K
L
M
N
O
P