

# SECTION **PWC**

## POWER WINDOW CONTROL SYSTEM

A  
B  
C  
D  
E  
F  
G  
H  
I  
J  
L  
M  
N  
O  
P

### CONTENTS

<p><b>BASIC INSPECTION</b> ..... 4</p> <p><b>DIAGNOSIS AND REPAIR WORK FLOW</b> ..... 4</p> <p style="padding-left: 20px;">WorkFlow .....4</p> <p><b>INSPECTION AND ADJUSTMENT</b> ..... 5</p> <p><b>ADDITIONAL SERVICE WHEN REMOVING BATTERY NEGATIVE TERMINAL</b> .....5</p> <p style="padding-left: 20px;">ADDITIONAL SERVICE WHEN REMOVING BATTERY NEGATIVE TERMINAL : Description .....5</p> <p style="padding-left: 20px;">ADDITIONAL SERVICE WHEN REMOVING BATTERY NEGATIVE TERMINAL : Special Repair Requirement .....5</p> <p><b>ADDITIONAL SERVICE WHEN REPLACING CONTROL UNIT</b> .....5</p> <p style="padding-left: 20px;">ADDITIONAL SERVICE WHEN REPLACING CONTROL UNIT : Description .....5</p> <p style="padding-left: 20px;">ADDITIONAL SERVICE WHEN REPLACING CONTROL UNIT : Special Repair Requirement .....6</p> <p><b>SYSTEM DESCRIPTION</b> ..... 7</p> <p><b>POWER WINDOW SYSTEM</b> ..... 7</p> <p style="padding-left: 20px;">System Diagram .....7</p> <p style="padding-left: 20px;">System Description .....7</p> <p style="padding-left: 20px;">Component Parts Location .....9</p> <p style="padding-left: 20px;">Component Description .....9</p> <p><b>DIAGNOSIS SYSTEM (BCM) (WITH INTELLIGENT KEY SYSTEM)</b> .....11</p> <p><b>COMMON ITEM</b> .....11</p> <p style="padding-left: 20px;">COMMON ITEM : CONSULT Function (BCM - COMMON ITEM) ..... 11</p> <p><b>RETAIND PWR</b> .....12</p> <p style="padding-left: 20px;">RETAIND PWR : CONSULT Function (BCM - RETAINED PWR) ..... 12</p> <p><b>DIAGNOSIS SYSTEM (BCM) (WITHOUT INTELLIGENT KEY SYSTEM)</b> .....14</p>	<p><b>COMMON ITEM</b> .....14</p> <p style="padding-left: 20px;">COMMON ITEM : CONSULT Function (BCM - COMMON ITEM) .....14</p> <p><b>RETAIND PWR</b> .....14</p> <p style="padding-left: 20px;">RETAIND PWR : CONSULT Function (BCM - RETAINED PWR) .....14</p> <p><b>DTC/CIRCUIT DIAGNOSIS</b> ..... 16</p> <p><b>POWER SUPPLY AND GROUND CIRCUIT</b> ....16</p> <p><b>POWER WINDOW MAIN SWITCH</b> .....16</p> <p style="padding-left: 20px;">POWER WINDOW MAIN SWITCH : Diagnosis Procedure .....16</p> <p><b>FRONT POWER WINDOW SWITCH (PASSENGER SIDE)</b> .....17</p> <p style="padding-left: 20px;">FRONT POWER WINDOW SWITCH (PASSENGER SIDE) : Diagnosis Procedure .....17</p> <p><b>REAR POWER WINDOW SWITCH</b> .....17</p> <p style="padding-left: 20px;">REAR POWER WINDOW SWITCH : Diagnosis Procedure .....17</p> <p><b>FRONT POWER WINDOW SWITCH (PASSENGER SIDE)</b> .....19</p> <p style="padding-left: 20px;">Description .....19</p> <p style="padding-left: 20px;">Component Function Check .....19</p> <p style="padding-left: 20px;">Diagnosis Procedure .....19</p> <p style="padding-left: 20px;">Component Inspection .....20</p> <p><b>REAR POWER WINDOW SWITCH</b> .....21</p> <p style="padding-left: 20px;">Description .....21</p> <p style="padding-left: 20px;">Component Function Check .....21</p> <p style="padding-left: 20px;">Diagnosis Procedure .....21</p> <p style="padding-left: 20px;">Component Inspection .....22</p> <p><b>POWER WINDOW MOTOR</b> .....23</p> <p><b>DRIVER SIDE</b> .....23</p> <p style="padding-left: 20px;">DRIVER SIDE : Description .....23</p> <p style="padding-left: 20px;">DRIVER SIDE : Component Function Check .....23</p>
--	---



DRIVER SIDE : Diagnosis Procedure .....	23	<b>FRONT PASSENGER SIDE POWER WINDOW DOES NOT OPERATE .....</b>	<b>103</b>
<b>PASSENGER SIDE .....</b>	<b>24</b>	<b>WITH BOTH POWER WINDOW MAIN SWITCH AND FRONT PASSENGER SIDE POWER WINDOW SWITCH .....</b>	<b>103</b>
PASSENGER SIDE : Description .....	24	WITH BOTH POWER WINDOW MAIN SWITCH AND FRONT PASSENGER SIDE POWER WINDOW SWITCH : Diagnosis Procedure .....	103
PASSENGER SIDE : Component Function Check .....	24	<b>WITH FRONT POWER WINDOW SWITCH ONLY .</b>	<b>103</b>
PASSENGER SIDE : Diagnosis Procedure .....	24	WITH FRONT POWER WINDOW SWITCH ONLY : Diagnosis Procedure .....	103
<b>REAR LH .....</b>	<b>25</b>	<b>REAR LH SIDE POWER WINDOW DOES NOT OPERATE .....</b>	<b>104</b>
REAR LH : Description .....	25	<b>WITH BOTH POWER WINDOW MAIN SWITCH AND REAR POWER WINDOW SWITCH LH .....</b>	<b>104</b>
REAR LH : Component Function Check .....	25	WITH BOTH POWER WINDOW MAIN SWITCH AND REAR POWER WINDOW SWITCH LH : Diagnosis Procedure .....	104
REAR LH : Diagnosis Procedure .....	25	<b>WITH REAR POWER WINDOW SWITCH LH ONLY .....</b>	<b>104</b>
<b>REAR RH .....</b>	<b>26</b>	WITH REAR POWER WINDOW SWITCH LH ONLY : Diagnosis Procedure .....	104
REAR RH : Description .....	26	<b>REAR RH SIDE POWER WINDOW DOES NOT OPERATE .....</b>	<b>105</b>
REAR RH : Component Function Check .....	26	<b>WITH BOTH POWER WINDOW MAIN SWITCH AND REAR POWER WINDOW SWITCH RH .....</b>	<b>105</b>
REAR RH : Diagnosis Procedure .....	26	WITH BOTH POWER WINDOW MAIN SWITCH AND REAR POWER WINDOW SWITCH RH : Diagnosis Procedure .....	105
<b>ENCODER CIRCUIT .....</b>	<b>28</b>	<b>WITH REAR POWER WINDOW SWITCH RH ONLY .....</b>	<b>105</b>
Description .....	28	WITH REAR POWER WINDOW SWITCH RH ONLY : Diagnosis Procedure .....	105
Component Function Check .....	28	<b>ANTI-PINCH SYSTEM DOES NOT OPERATE NORMALLY (DRIVER SIDE) .....</b>	<b>106</b>
Diagnosis Procedure .....	28	Diagnosis Procedure .....	106
<b>ECU DIAGNOSIS INFORMATION .....</b>	<b>31</b>	<b>POWER WINDOW RETAINED POWER OPERATION DOES NOT OPERATE PROPERLY .....</b>	<b>107</b>
<b>BCM (BODY CONTROL MODULE) .....</b>	<b>31</b>	Diagnosis Procedure .....	107
<b>WITH INTELLIGENT KEY .....</b>	<b>31</b>	<b>AUTO OPERATION DOES NOT OPERATE BUT MANUAL OPERATE NORMALLY (DRIVER SIDE) .....</b>	<b>108</b>
WITH INTELLIGENT KEY : Reference Value .....	31	Diagnosis Procedure .....	108
WITH INTELLIGENT KEY : Wiring Diagram - BCM - .....	51	<b>POWER WINDOW LOCK SWITCH DOES NOT FUNCTION .....</b>	<b>109</b>
WITH INTELLIGENT KEY : Fail-safe .....	62	Diagnosis Procedure .....	109
WITH INTELLIGENT KEY : DTC Inspection Priority Chart .....	63	<b>PRECAUTION .....</b>	<b>110</b>
WITH INTELLIGENT KEY : DTC Index .....	64		
<b>WITHOUT INTELLIGENT KEY .....</b>	<b>66</b>		
WITHOUT INTELLIGENT KEY : Reference Value..	66		
WITHOUT INTELLIGENT KEY : Wiring Diagram - BCM - .....	80		
WITHOUT INTELLIGENT KEY : Fail-safe .....	88		
WITHOUT INTELLIGENT KEY : DTC Inspection Priority Chart .....	89		
WITHOUT INTELLIGENT KEY : DTC Index .....	89		
<b>POWER WINDOW MAIN SWITCH .....</b>	<b>91</b>		
Reference Value .....	91		
Wiring Diagram - POWER WINDOW CONTROL SYSTEM - .....	93		
Fail Safe .....	99		
<b>SYMPTOM DIAGNOSIS .....</b>	<b>101</b>		
<b>NONE OF THE POWER WINDOWS CAN BE OPERATED USING ANY SWITCH .....</b>	<b>101</b>		
Diagnosis Procedure .....	101		
<b>DRIVER SIDE POWER WINDOW DOES NOT OPERATE .....</b>	<b>102</b>		
Diagnosis Procedure .....	102		

<b>PRECAUTIONS</b> .....	<b>110</b>	<b>PREPARATION</b> .....	<b>111</b>	
Precaution for Supplemental Restraint System (SRS) "AIR BAG" and "SEAT BELT PRE-TEN- SIONER" .....	110	Commercial Service Tools .....	111	A
Precautions for Removing of Battery Terminal ....	110	<b>REMOVAL AND INSTALLATION</b> .....	<b>112</b>	
<b>PREPARATION</b> .....	<b>111</b>	<b>POWER WINDOW MAIN SWITCH</b> .....	<b>112</b>	B
		Removal and Installation .....	112	

C

D

E

F

G

H

I

J

**PWC**

L

M

N

O

P

# DIAGNOSIS AND REPAIR WORK FLOW

< BASIC INSPECTION >

## BASIC INSPECTION

### DIAGNOSIS AND REPAIR WORK FLOW

WorkFlow

INFOID:000000009950844

DETAILED FLOW

#### 1.OBTAIN INFORMATION ABOUT SYMPTOM

---

Interview the customer to obtain the malfunction information (conditions and environment when the malfunction occurred) as much as possible when the customer brings the vehicle in.

>> GO TO 2.

#### 2.REPRODUCE THE MALFUNCTION INFORMATION

---

Check the malfunction on the vehicle that the customer describes.  
Inspect the relation of the symptoms and the condition when the symptoms occur.

>> GO TO 3.

#### 3.IDENTIFY THE MALFUNCTIONING SYSTEM WITH "SYMPTOM DIAGNOSIS"

---

Use "Symptom diagnosis" from the symptom inspection result in step 2 and then identify where to start performing the diagnosis based on possible causes and symptoms.

>> GO TO 4.

#### 4.IDENTIFY THE MALFUNCTIONING PARTS WITH "COMPONENT DIAGNOSIS"

---

Perform the diagnosis with "Component diagnosis" of the applicable system.

>> GO TO 5.

#### 5.REPAIR OR REPLACE THE MALFUNCTIONING PARTS

---

Repair or replace the specified malfunctioning parts.

>> GO TO 6.

#### 6.FINAL CHECK

---

Check that malfunctions are not reproduced when obtaining the malfunction information from the customer, referring to the symptom inspection result in step 2.

Are the malfunctions corrected?

YES >> INSPECTION END

NO >> GO TO 3.

# INSPECTION AND ADJUSTMENT

< BASIC INSPECTION >

## INSPECTION AND ADJUSTMENT

### ADDITIONAL SERVICE WHEN REMOVING BATTERY NEGATIVE TERMINAL

#### ADDITIONAL SERVICE WHEN REMOVING BATTERY NEGATIVE TERMINAL : Description

INFOID:000000009950845

If any of the following work has been done Initial setting is necessary.

- Power supply to the power window main switch or power window motor is cut off by the removal of battery terminal or the battery fuse is blown.
- Disconnection and connection of power window main switch harness connector.
- Removal and installation of motor from regulator assembly.
- Operation of regulator assembly as an independent unit.
- Removal and installation of glass.
- Removal and installation of door glass run.

#### NOTE:

The following specified operations can not be performed under the non-initialized condition.

- Auto-up operation
- Anti-pinch function
- Retained power operation

Refer to [PWC-5, "ADDITIONAL SERVICE WHEN REMOVING BATTERY NEGATIVE TERMINAL : Special Repair Requirement"](#).

#### ADDITIONAL SERVICE WHEN REMOVING BATTERY NEGATIVE TERMINAL : Special Repair Requirement

INFOID:000000009950846

#### INITIALIZATION PROCEDURE

1. Disconnect battery minus terminal or power window main switch connector. Reconnect it after a minute or more.
2. Turn ignition switch ON.
3. Operate power window switch to fully open the window. (This operation is unnecessary if the window is already fully open)
4. Continue pulling the power window switch UP (AUTO-UP operation). Even after glass stops at fully closed position, keep pulling the switch for 2 seconds or more.
5. Initializing procedure is completely.
6. Inspect anti-pinch function.

#### CHECK ANTI-PINCH FUNCTION

1. Fully open the door window.
  2. Place a piece of wood near fully closed position.
  3. Close door glass completely with AUTO-UP.
- Check that glass lowers for approximately 150 mm (5.9 in) without pinching piece of wood and stops.
  - Check that glass does not rise when operating the power window main switch while lowering.

#### CAUTION:

- Perform initial setting when auto-up operation or anti-pinch function does not operate normally.
- Check that AUTO-UP operates before inspection when system initialization is performed.
- Do not check with hands and other body parts because they may be pinched. Do not get pinched.
- It may switch to fail-safe mode if open/close operation is performed continuously without full close. Perform initial setting in that situation. Refer to [PWC-99, "Fail Safe"](#)
- Finish initial setting. Otherwise, next operation cannot be done.

1. Auto-up operation
2. Anti-pinch function
3. Retained power operation

#### ADDITIONAL SERVICE WHEN REPLACING CONTROL UNIT

#### ADDITIONAL SERVICE WHEN REPLACING CONTROL UNIT : Description

INFOID:000000009950847

Refer to [PWC-5, "ADDITIONAL SERVICE WHEN REMOVING BATTERY NEGATIVE TERMINAL : Description"](#).

A  
B  
C  
D  
E  
F  
G  
H  
I  
J  
L  
M  
N  
O  
P

PWC

## INSPECTION AND ADJUSTMENT

< BASIC INSPECTION >

ADDITIONAL SERVICE WHEN REPLACING CONTROL UNIT : Special Repair Requirement

---

INFOID:000000009950848

Refer to [PWC-5, "ADDITIONAL SERVICE WHEN REMOVING BATTERY NEGATIVE TERMINAL : Special Repair Requirement"](#) for initialization procedure and check anti-pinch function.

# POWER WINDOW SYSTEM

< SYSTEM DESCRIPTION >

## SYSTEM DESCRIPTION

### POWER WINDOW SYSTEM

#### System Diagram

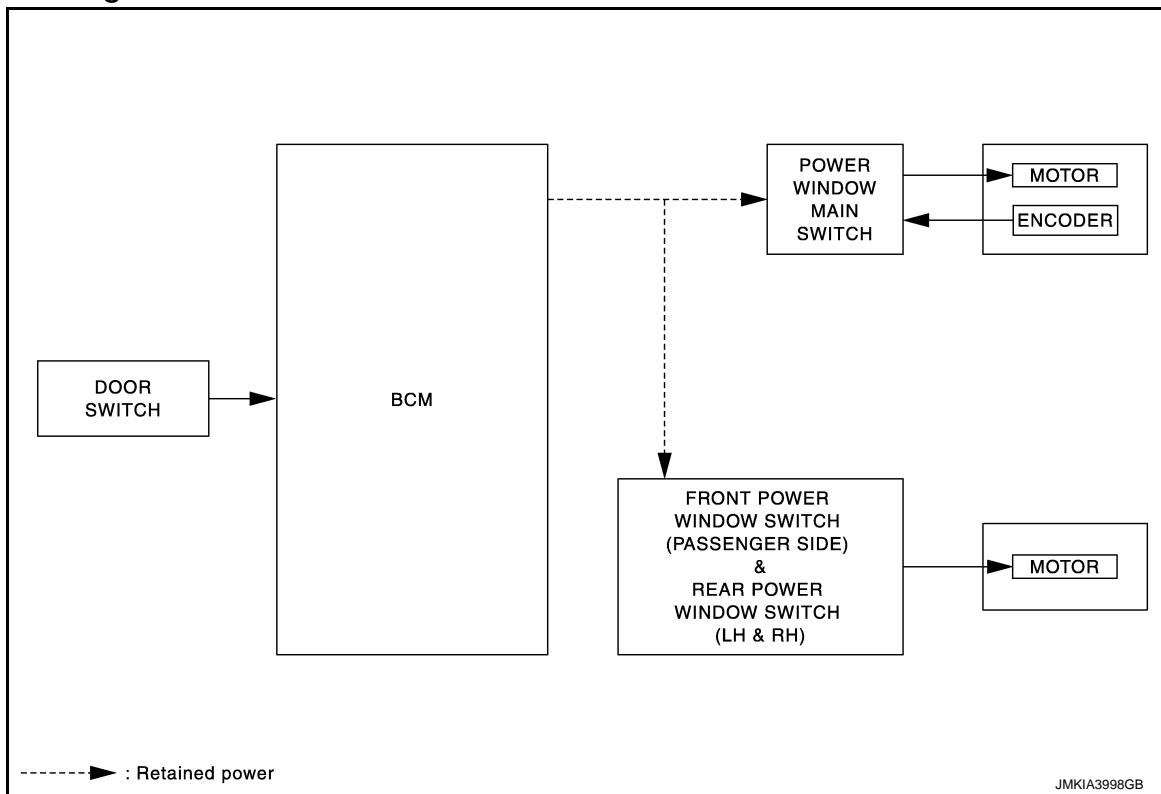

#### System Description

INFOID:0000000009950850

- Power window system is activated by power window switch when ignition switch turns ON, or during the retained power operation after ignition switch turns OFF.
- Power window main switch opens/closes all door glass.
- Front and rear power window switch opens/closes the corresponding door glass.
- AUTO UP/DOWN operation can be performed when power window main switch turns to AUTO.
- Power window lock switch can lock all power windows other than driver seat.
- If door glass receives resistance that is the specified value or more while power window of driver seat is in AUTO-UP operation, power window of driver seat operates in the reverse direction.

#### POWER WINDOW AUTO-OPERATION (FRONT DRIVER SIDE)

- AUTO UP/DOWN operation can be performed when power window main switch turns to AUTO.
- Encoder continues detecting the movement of power window motor and transmits to power window switch as the encoder pulse signal while power window motor is operating.
- Power window switch reads the changes of encoder signal and stops AUTO operation when door glass is at fully opened/closed position.
- Power window motor is operable in case encoder is malfunctioning.

#### RETAINED POWER OPERATION

Retained power operation is an additional power supply function that enables power window system to operate for 45 seconds even when ignition switch is turned OFF.

#### Retained Power Cancel Conditions

- Front door CLOSE (door switch OFF) → OPEN (door switch ON).
- When ignition switch is ON again.
- When timer time passes (45 seconds).

#### POWER WINDOW LOCK

A  
B  
C  
D  
E  
F  
G  
H  
I  
J  
L  
M  
N  
O  
P

PWC

# POWER WINDOW SYSTEM

## < SYSTEM DESCRIPTION >

---

Ground circuit inside power window main switch shuts off when power window lock switch is ON. This inhibits each power window switch operation except the power window main switch.

### ANTI-PINCH SYSTEM (FRONT DRIVER SIDE)

- Pinch foreign material in the door glass during AUTO-UP operation, and it is the anti-pinch function that lowers the door glass 150 mm (5.9 in) when detected.
- Encoder continues detecting the movement of front power window motor (driver side) and transmits to power window main switch as the encoder pulse signal while front power window motor (driver side) is operating.
- Resistance is applied to the front power window motor (driver side) rotation that changes the frequency of encoder pulse signal if foreign material is trapped in the door glass.
- Power window main switch controls to lower the window glass for 150 mm (5.9 in) after it detects encoder pulse signal frequency change.

#### Operation Condition

When front door glass (driver side) AUTO-UP operation is performed (anti-pinch function does not operate just before the door glass closes and is fully closed).

#### **NOTE:**

Depending on environment and driving conditions, if a similar impact or load is applied to the door glass, it may lower.



# POWER WINDOW SYSTEM

< SYSTEM DESCRIPTION >

## Component Parts Location

INFOID:000000009950851

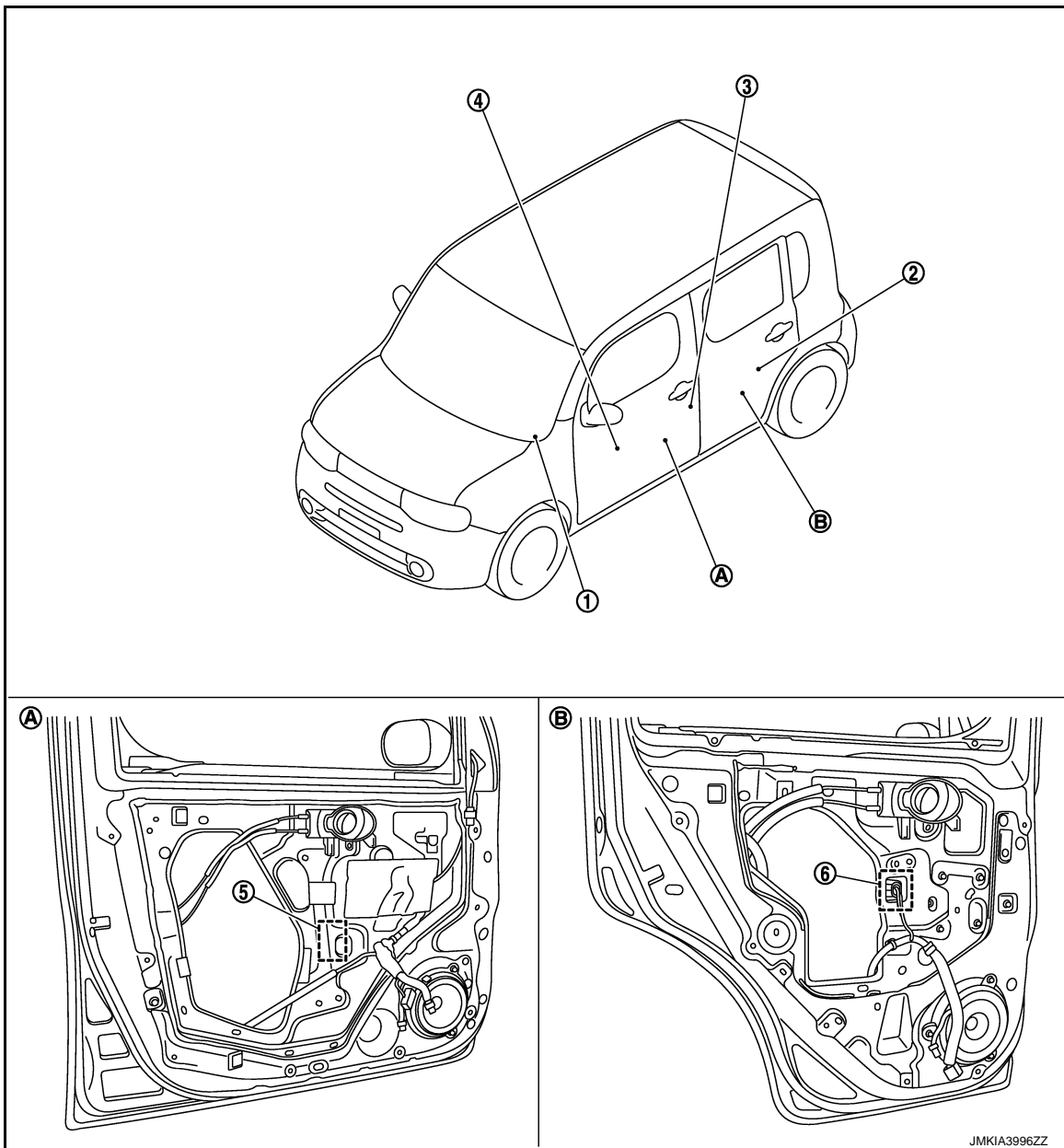

- |   |   |                                    |
|---|---|------------------------------------|
| 1. BCM Refer to <a href="#">BCS-10, "Component Parts Location"</a> (With Intelligent Key) or <a href="#">BCS-95, "Component Parts Location"</a> (Without Intelligent Key) | 2. Rear power window switch LH            | 3. Front door switch (driver side) |
| 4. Power window main switch   | 5. Front power window motor (driver side) | 6. Rear power window motor LH      |
| A. View with front door finisher removed.   | B. View with rear door finisher removed.  |                                    |

## Component Description

INFOID:000000009950852

Component parts	Description
BCM	<ul style="list-style-type: none"> <li>Supplies power supply to power window switch.</li> <li>Controls retained power.</li> </ul>
Power window main switch	<ul style="list-style-type: none"> <li>Directly controls all power window motor of all doors.</li> <li>Controls anti-pinch operation of power window.</li> </ul>

A  
B  
C  
D  
E  
F  
G  
H  
I  
J  
K  
L  
M  
N  
O  
P

PWC

# POWER WINDOW SYSTEM

## < SYSTEM DESCRIPTION >

Component parts	Description
Front power window switch (passenger side)	Controls power window motor of front passenger side door.
Rear power window switch (LH & RH)	Controls power window motor of rear door (LH & RH).
Front power window motor (driver side)	<ul style="list-style-type: none"><li>• Integrates the encoder and power window motor.</li><li>• Operates with signals from power window main switch.</li><li>• Transmits front power window motor (driver side) rotation as a pulse signal to power window main switch.</li></ul>
Front power window motor (passenger side)	Operates with signals from power window main switch and front power window switch (passenger side).
Rear power window motor (LH & RH)	Operates with signals from power window main switch and rear power window switch (LH & RH).
Encoder	Detects condition of the front power window motor (driver side) operation and transmits to power window main switch as pulse signal.
Front door switch	Detects door open/close condition and transmits to BCM.

# DIAGNOSIS SYSTEM (BCM) (WITH INTELLIGENT KEY SYSTEM)

< SYSTEM DESCRIPTION >

## DIAGNOSIS SYSTEM (BCM) (WITH INTELLIGENT KEY SYSTEM) COMMON ITEM

COMMON ITEM : CONSULT Function (BCM - COMMON ITEM)

INFOID:0000000010229661

### APPLICATION ITEM

CONSULT performs the following functions via CAN communication with BCM.

Diagnosis mode	Function Description
Work Support	Changes the setting for each system function.
Self Diagnostic Result	Displays the diagnosis results judged by BCM.
CAN Diag Support Monitor	Monitors the reception status of CAN communication viewed from BCM.
Data Monitor	The BCM input/output signals are displayed.
Active Test	The signals used to activate each device are forcibly supplied from BCM.
Ecu Identification	The BCM part number is displayed.
Configuration	<ul style="list-style-type: none"> <li>Read and save the vehicle specification.</li> <li>Write the vehicle specification when replacing BCM.</li> </ul>

### SYSTEM APPLICATION

BCM can perform the following functions for each system.

#### NOTE:

It can perform the diagnosis modes except the following for all sub system selection items.

×: Applicable item

System	Sub system selection item	Diagnosis mode		
		Work Support	Data Monitor	Active Test
Door lock	DOOR LOCK	×	×	×
Rear window defogger	REAR DEFOGGER		×	×
Warning chime	BUZZER		×	×
Interior room lamp timer	INT LAMP	×	×	×
Exterior lamp	HEAD LAMP	×	×	×
Wiper and washer	WIPER	×	×	×
Turn signal and hazard warning lamps	FLASHER	×	×	×
Automatic air conditioner	AIR CONDITONER		×	
<ul style="list-style-type: none"> <li>Intelligent Key system</li> <li>Engine start system</li> </ul>	INTELLIGENT KEY	×	×	×
Combination switch	COMB SW		×	
Body control system	BCM	×		
NVIS - NATS	IMMU	×	×	×
Interior room lamp battery saver	BATTERY SAVER	×	×	×
Back door	TRUNK		×	
Vehicle security system	THEFT ALM	×	×	×
RAP system	RETAINED PWR		×	
Signal buffer system	SIGNAL BUFFER		×	×
TPMS	TPMS (AIR PRESSURE MONITOR)	×	×	×

### FREEZE FRAME DATA (FFD)

The BCM records the following vehicle condition at the time a particular DTC is detected, and displays on CONSULT.

# DIAGNOSIS SYSTEM (BCM) (WITH INTELLIGENT KEY SYSTEM)

## < SYSTEM DESCRIPTION >

CONSULT screen item	Indication/Unit	Description	
Vehicle Speed	km/h	Vehicle speed of the moment a particular DTC is detected	
Odo/Trip Meter	km	Total mileage (Odometer value) of the moment a particular DTC is detected	
Vehicle Condition	SLEEP>LOCK	Power position status of the moment a particular DTC is detected	While turning BCM status from low power consumption mode to normal mode (Power supply position is "LOCK"*)
	SLEEP>OFF		While turning BCM status from low power consumption mode to normal mode (Power supply position is "OFF".)
	LOCK>ACC		While turning power supply position from "LOCK"* to "ACC"
	ACC>ON		While turning power supply position from "ACC" to "IGN"
	RUN>ACC		While turning power supply position from "RUN" to "ACC" (Vehicle is stopping and selector lever is except P position.)
	CRANK>RUN		While turning power supply position from "CRANKING" to "RUN" (From cranking up the engine to run it)
	RUN>URGENT		While turning power supply position from "RUN" to "ACC" (Emergency stop operation)
	ACC>OFF		While turning power supply position from "ACC" to "OFF"
	OFF>LOCK		While turning power supply position from "OFF" to "LOCK"*
	OFF>ACC		While turning power supply position from "OFF" to "ACC"
	ON>CRANK		While turning power supply position from "IGN" to "CRANKING"
	OFF>SLEEP		While turning BCM status from normal mode (Power supply position is "OFF".) to low power consumption mode
	LOCK>SLEEP		While turning BCM status from normal mode (Power supply position is "LOCK"*) to low power consumption mode
	LOCK		Power supply position is "LOCK"*
	OFF		Power supply position is "OFF" (Ignition switch OFF)
	ACC		Power supply position is "ACC" (Ignition switch ACC)
	ON		Power supply position is "IGN" (Ignition switch ON with engine stopped)
	ENGINE RUN		Power supply position is "RUN" (Ignition switch ON with engine running)
CRANKING	Power supply position is "CRANKING" (At engine cranking)		
IGN Counter	0 - 39	The number of times that ignition switch is turned ON after DTC is detected <ul style="list-style-type: none"> <li>• The number is 0 when a malfunction is detected now.</li> <li>• The number increases like 1 → 2 → 3...38 → 39 after returning to the normal condition whenever ignition switch OFF → ON.</li> <li>• The number is fixed to 39 until the self-diagnosis results are erased if it is over 39.</li> </ul>	

### NOTE:

\*: Power position shifts to "LOCK" from "OFF", when ignition switch is in the OFF position, selector lever is in the P position (CVT models), and any of the following conditions are met.

- Closing door
- Opening door
- Door is locked using door request switch
- Door is locked using Intelligent Key

The power position shifts to "ACC" when the push-button ignition switch (push switch) is pushed at "LOCK".

## RETAINED PWR

### RETAINED PWR : CONSULT Function (BCM - RETAINED PWR)

INFOID:000000010229662

### DATA MONITOR

#### NOTE:

The following table includes information (items) inapplicable to this vehicle. For information (items) applicable to this vehicle, refer to CONSULT display items.

# DIAGNOSIS SYSTEM (BCM) (WITH INTELLIGENT KEY SYSTEM)

## < SYSTEM DESCRIPTION >

Monitor Item	Description
DOOR SW-DR	Indicates [ON/OFF] condition of driver side door switch.
DOOR SW-AS	Indicates [ON/OFF] condition of passenger side door switch.

A

B

C

D

E

F

G

H

I

J

PWC

L

M

N

O

P

## DIAGNOSIS SYSTEM (BCM) (WITHOUT INTELLIGENT KEY SYSTEM)

< SYSTEM DESCRIPTION >

### DIAGNOSIS SYSTEM (BCM) (WITHOUT INTELLIGENT KEY SYSTEM) COMMON ITEM

COMMON ITEM : CONSULT Function (BCM - COMMON ITEM)

INFOID:000000010229663

#### APPLICATION ITEM

CONSULT performs the following functions via CAN communication with BCM.

Diagnosis mode	Function Description
Work Support	Changes the setting for each system function.
Self Diagnostic Result	Displays the diagnosis results judged by BCM.
CAN Diag Support Monitor	Monitors the reception status of CAN communication viewed from BCM.
Data Monitor	The BCM input/output signals are displayed.
Active Test	The signals used to activate each device are forcibly supplied from BCM.
Ecu Identification	The BCM part number is displayed.
Configuration	<ul style="list-style-type: none"> <li>Read and save the vehicle specification.</li> <li>Write the vehicle specification when replacing BCM.</li> </ul>

#### SYSTEM APPLICATION

BCM can perform the following functions for each system.

##### NOTE:

It can perform the diagnosis modes except the following for all sub system selection items.

×: Applicable item

System	Sub system selection item	Diagnosis mode		
		Work Support	Data Monitor	Active Test
Door lock	DOOR LOCK	×	×	×
Rear window defogger	REAR DEFOGGER		×	×
Warning chime	BUZZER		×	×
Interior room lamp control	INT LAMP	×	×	×
Remote keyless entry system	MULTI REMOTE ENT	×	×	×
Exterior lamp	HEAD LAMP	×	×	×
Wiper and washer	WIPER	×	×	×
Turn signal and hazard warning lamps	FLASHER		×	×
Manual air conditioner	AIR CONDITONER		×	×
Combination switch	COMB SW		×	
Body control system	BCM	×		
NVIS - NATS	IMMU	×	×	×
Interior room lamp battery saver	BATTERY SAVER	×	×	×
Back door	TRUNK		×	
Vehicle security system	THEFT ALM	×	×	×
RAP system	RETAINED PWR		×	×
Signal buffer system	SIGNAL BUFFER		×	×
TPMS	TPMS (AIR PRESSURE MONITOR)	×	×	×
Panic alarm system	PANIC ALARM			×

#### RETAINED PWR

RETAINED PWR : CONSULT Function (BCM - RETAINED PWR)

INFOID:000000010229664

#### DATA MONITOR

##### NOTE:

# DIAGNOSIS SYSTEM (BCM) (WITHOUT INTELLIGENT KEY SYSTEM)

## < SYSTEM DESCRIPTION >

The following table includes information (items) inapplicable to this vehicle. For information (items) applicable to this vehicle, refer to CONSULT display items.

Monitor Item	Description
DOOR SW-DR	Indicates [ON/OFF] condition of driver side door switch.
DOOR SW-AS	Indicates [ON/OFF] condition of passenger side door switch.

A

B

C

D

E

F

G

H

I

J

PWC

L

M

N

O

P

# POWER SUPPLY AND GROUND CIRCUIT

< DTC/CIRCUIT DIAGNOSIS >

## DTC/CIRCUIT DIAGNOSIS

### POWER SUPPLY AND GROUND CIRCUIT

#### POWER WINDOW MAIN SWITCH

#### POWER WINDOW MAIN SWITCH : Diagnosis Procedure

INFOID:000000009950857

#### 1. CHECK POWER SUPPLY CIRCUIT

1. Turn ignition OFF.
2. Disconnect power window main switch connector.
3. Turn ignition switch ON.
4. Check voltage between power window main switch harness connector and ground.

(+)		(-)	Voltage (V) (Approx.)
Power window main switch			
Connector	Terminal	Ground	Battery voltage
D5	10		
D6	19		

Is the inspection result normal?

- YES >> GO TO 2.  
NO >> GO TO 3.

#### 2. CHECK GROUND CIRCUIT

1. Turn ignition switch OFF.
2. Check continuity between power window main switch harness connector and ground.

Power window main switch		Ground	Continuity
Connector	Terminal		
D6	17		Existed

Is the inspection result normal?

- YES >> INSPECTION END  
NO >> Repair or replace harness.

#### 3. CHECK HARNESS CONTINUITY

1. Turn ignition switch OFF.
2. Disconnect BCM connector.
3. Check continuity between BCM harness connector and power window main switch harness connector.

BCM		Power window main switch		Continuity
Connector	Terminal	Connector	Terminal	
M67: Without Intelligent Key M70: With Intelligent Key	68	D5	10	Existed
	69	D6	19	

4. Check continuity between BCM harness connector and ground.

BCM		Ground	Continuity
Connector	Terminal		
M67: Without Intelligent Key M70: With Intelligent Key	68		Not existed
	69		

Is the inspection result normal?

- YES >> Replace BCM. Refer to [BCS-88. "Removal and Installation"](#) (With Intelligent Key). Refer [BCS-155. "Removal and Installation"](#) (Without Intelligent Key).  
NO >> Repair or replace harness.



# POWER SUPPLY AND GROUND CIRCUIT

< DTC/CIRCUIT DIAGNOSIS >

## FRONT POWER WINDOW SWITCH (PASSENGER SIDE)

### FRONT POWER WINDOW SWITCH (PASSENGER SIDE) : Diagnosis Procedure

INFOID:000000009950858

#### 1. CHECK POWER SUPPLY CIRCUIT

1. Turn ignition switch OFF.
2. Disconnect front power window switch (passenger side) connector.
3. Turn ignition switch ON.
4. Check voltage between front power window switch (passenger side) harness connector and ground.

(+)		(-)	Voltage (V) (Approx.)
Connector	Terminal		
D25	8	Ground	Battery voltage

Is the inspection result normal?

- YES >> INSPECTION END  
NO >> GO TO 2.

#### 2. CHECK HARNESS CONTINUITY

1. Turn ignition switch OFF.
2. Disconnect BCM connector.
3. Check continuity between BCM harness connector and front power window switch (passenger side) harness connector.

BCM		Front power window switch (passenger side)		Continuity
Connector	Terminal	Connector	Terminal	
M67: Without Intelligent Key M70: With Intelligent Key	68	D25	8	Existed

4. Check continuity between BCM harness connector and ground.

BCM		Ground	Continuity
Connector	Terminal		
M67: Without Intelligent Key M70: With Intelligent Key	68		Not existed

Is the inspection result normal?

- YES >> Replace BCM. Refer to [BCS-88, "Removal and Installation"](#) (With Intelligent Key). Refer to [BCS-155, "Removal and Installation"](#) (Without Intelligent Key).  
NO >> Repair or replace harness.

## REAR POWER WINDOW SWITCH

### REAR POWER WINDOW SWITCH : Diagnosis Procedure

INFOID:000000009950859

#### 1. CHECK POWER SUPPLY CIRCUIT

1. Turn ignition switch OFF.
2. Disconnect rear power window switch connector.
3. Turn ignition switch ON.
4. Check voltage between rear power window switch harness connector and ground.

# POWER SUPPLY AND GROUND CIRCUIT

## < DTC/CIRCUIT DIAGNOSIS >

(+)		Terminal	(-)	Voltage (V) (Approx.)
Rear power window switch				
Connector				
LH	D63	1	Ground	Battery voltage
RH	D43			

Is the inspection result normal?

YES >> INSPECTION END

NO >> GO TO 2.

## 2. CHECK HARNESS CONTINUITY

1. Turn ignition switch OFF.
2. Disconnect BCM connector.
3. Check continuity between BCM harness connector and rear power window switch harness connector.

BCM		Rear power window switch		Continuity
Connector	Terminal	Connector	Terminal	
M67: Without Intelligent Key M70: With Intelligent Key	68	LH	D63	1
		RH	D43	

4. Check continuity between BCM harness connector and ground.

BCM		Ground	Continuity
Connector	Terminal		
M67: Without Intelligent Key M70: With Intelligent Key	68		Not existed

Is the inspection result normal?

YES >> Replace BCM. Refer to [BCS-88, "Removal and Installation"](#) (With Intelligent Key). Refer to [BCS-155, "Removal and Installation"](#) (Without Intelligent Key).

NO >> Repair or replace harness.

# FRONT POWER WINDOW SWITCH (PASSENGER SIDE)

< DTC/CIRCUIT DIAGNOSIS >

## FRONT POWER WINDOW SWITCH (PASSENGER SIDE)

### Description

INFOID:000000009950860

Front power window motor (passenger side) will be operated if front power window switch (passenger side) is operated.

### Component Function Check

INFOID:000000009950861

#### 1. CHECK FRONT POWER WINDOW SWITCH (PASSENGER SIDE) FUNCTION

Check front power window motor (passenger side) operation with front power window switch (passenger side).

Is the inspection result normal?

- YES >> Front power window switch (passenger side) is OK.
- NO >> Refer to [PWC-19, "Diagnosis Procedure"](#).

### Diagnosis Procedure

INFOID:000000009950862

#### 1. CHECK FRONT POWER WINDOW SWITCH (PASSENGER SIDE) INPUT SIGNAL

1. Turn ignition switch OFF.
2. Disconnect front power window switch (passenger side) connector.
3. Turn ignition switch ON.
4. Check voltage between front power window switch (passenger side) harness connector and ground.

(+)		(-)	Condition	Voltage (V) (Approx.)
Connector	Terminal			
D25	12	Ground	UP	Battery voltage
			DOWN	0
	11		UP	0
			DOWN	Battery voltage

Is the inspection result normal?

- YES >> GO TO 2.
- NO >> GO TO 3.

#### 2. CHECK FRONT POWER WINDOW SWITCH (PASSENGER SIDE)

Check front power window switch (passenger side).

Refer to [PWC-20, "Component Inspection"](#).

Is the inspection result normal?

- YES >> GO TO 4.
- NO >> Replace front power window switch (passenger side). Refer to [PWC-112, "Removal and Installation"](#).

#### 3. CHECK FRONT WINDOW SWITCH (PASSENGER SIDE) CIRCUIT

1. Turn ignition switch OFF.
2. Disconnect power window main switch connector.
3. Check continuity between power window main switch harness connector and front power window switch (passenger side) harness connector.

Power window main switch		Front power window switch (passenger side)		Continuity
Connector	Terminal	Connector	Terminal	
D5	16	D25	12	Existed
	12		11	

4. Check continuity between power window main switch harness connector and ground.

A  
B  
C  
D  
E  
F  
G  
H  
I  
J  
L  
M  
N  
O  
P

PWC

# FRONT POWER WINDOW SWITCH (PASSENGER SIDE)

## < DTC/CIRCUIT DIAGNOSIS >

Power window main switch		Ground	Continuity
Connector	Terminal		
D5	16		
	12		

Is the inspection result normal?

YES >> Replace power window main switch. Refer to [PWC-112, "Removal and Installation"](#).

NO >> Repair or replace harness.

### 4.CHECK INTERMITTENT INCIDENT

Refer to [GI-40, "Intermittent Incident"](#).

>> INSPECTION END

## Component Inspection

INFOID:000000009950863

### 1.CHECK FRONT POWER WINDOW SWITCH (PASSENGER SIDE)

1. Turn ignition OFF.
2. Disconnect front power window switch (passenger side) connector.
3. Check front power window switch (passenger side).

Front power window switch (passenger side)		Front power window switch condition	Continuity
Terminal			
8	7	UP	Existed
11	6		
11	6	NEUTRAL	
12	7		
8	6	DOWN	
12	7		

Is the inspection result normal?

YES >> INSPECTION END

NO >> Replace front power window switch (passenger side). Refer to [PWC-112, "Removal and Installation"](#).

# REAR POWER WINDOW SWITCH

< DTC/CIRCUIT DIAGNOSIS >

## REAR POWER WINDOW SWITCH

### Description

INFOID:000000009950864

Rear power window motor will be operated if rear power window switch is operated.

### Component Function Check

INFOID:000000009950865

#### 1. CHECK REAR POWER WINDOW SWITCH FUNCTION

Check rear power window motor operation with rear power window switch.

Is the inspection result normal?

- YES >> Rear power window switch is OK.
- NO >> Refer to [PWC-21, "Diagnosis Procedure"](#).

### Diagnosis Procedure

INFOID:000000009950866

#### 1. CHECK REAR POWER WINDOW SWITCH INPUT SIGNAL

1. Turn ignition switch OFF.
2. Disconnect rear power window switch connector.
3. Turn ignition switch ON.
4. Check voltage between rear power window switch harness connector and ground.

(+)		(-)	Condition	Voltage (V) (Approx.)	
Rear power window switch					
Connector	Terminal				
LH: D63	2	Ground	Power window main switch: LH	UP	Battery voltage
				DOWN	0
	3		UP	0	
			DOWN	Battery voltage	
RH: D43	2		Power window main switch: RH	UP	Battery voltage
				DOWN	0
	3			UP	0
				DOWN	Battery voltage

Is the inspection result normal?

- YES >> GO TO 2.
- NO >> GO TO 3.

#### 2. CHECK REAR POWER WINDOW SWITCH

Check rear power window switch.

Refer to [PWC-22, "Component Inspection"](#).

Is the inspection result normal?

- YES >> GO TO 4.
- NO >> Replace rear power window switch. Refer to [PWC-112, "Removal and Installation"](#).

#### 3. CHECK REAR POWER WINDOW SWITCH CIRCUIT

1. Turn ignition switch OFF.
2. Disconnect power window main switch connector.
3. Check continuity between power window main switch harness connector and rear power window switch harness connector.

# REAR POWER WINDOW SWITCH

## < DTC/CIRCUIT DIAGNOSIS >

Power window main switch		Rear power window switch			Continuity
Connector	Terminal	Connector		Terminal	
D5	1	LH	D63	2	Existed
	3			3	
	5	RH	D43	3	
	7			2	

4. Check continuity between power window main switch harness connector and ground.

Power window main switch		Ground	Continuity
Connector	Terminal		
D5	1		Not existed
	3		
	5		
	7		

Is the inspection result normal?

YES >> Replace power window main switch. Refer to [PWC-112, "Removal and Installation"](#).

NO >> Repair or replace harness.

### 4.CHECK INTERMITTENT INCIDENT

Refer to [GI-40, "Intermittent Incident"](#).

>> INSPECTION END

## Component Inspection

INFOID:000000009950867

### 1.CHECK REAR POWER WINDOW SWITCH

- Turn ignition switch OFF.
- Disconnect rear power window switch connector.
- Check rear power window switch.

Rear power window switch		Rear power window switch condition	Continuity
Terminal			
1	5	UP	Existed
3	4		
3	4	NEUTRAL	
2	5		
1	4	DOWN	
2	5		

Is the inspection result normal?

YES >> INSPECTION END

NO >> Replace rear power window switch. Refer to [PWC-112, "Removal and Installation"](#).

# POWER WINDOW MOTOR

< DTC/CIRCUIT DIAGNOSIS >

## POWER WINDOW MOTOR DRIVER SIDE

### DRIVER SIDE : Description

INFOID:000000009950868

Door glass moves UP/DOWN by receiving the signal from power window main switch.

### DRIVER SIDE : Component Function Check

INFOID:000000009950869

#### 1. CHECK FRONT POWER WINDOW MOTOR (DRIVER SIDE) OPERATION

Check front power window motor (driver side) operation with power window main switch.

Is the inspection result normal?

- YES >> Front power window motor (driver side) is OK.  
 NO >> Refer to [PWC-23. "DRIVER SIDE : Diagnosis Procedure"](#).

### DRIVER SIDE : Diagnosis Procedure

INFOID:000000009950870

#### 1. CHECK POWER WINDOW MOTOR (DRIVER SIDE) INPUT SIGNAL

1. Turn ignition switch OFF.
2. Disconnect front power window motor (driver side) connector.
3. Turn ignition switch ON.
4. Check voltage between power window motor (driver side) harness connector and ground.

(+)		(-)	Condition	Voltage (V) (Approx.)
Connector	Terminal			
D7	1	Ground	Power window main switch UP	Battery voltage
			Power window main switch DOWN	0
	3		Power window main switch UP	0
			Power window main switch DOWN	Battery voltage

Is the inspection result normal?

- YES >> Replace power window motor (driver side). Refer to [GW-21. "Removal and Installation"](#).  
 NO >> GO TO 2.

#### 2. CHECK POWER WINDOW MOTOR CIRCUIT

1. Turn ignition switch OFF.
2. Disconnect power window main switch connector.
3. Check continuity between power window main switch harness connector and front power window motor (driver side) harness connector.

Power window main switch		Front power window motor (driver side)		Continuity
Connector	Terminal	Connector	Terminal	
D5	8	D7	1	Existed
	11		3	

4. Check continuity between power window main switch harness connector and ground.

Power window main switch		Ground	Continuity
Connector	Terminal		
D5	8		Not existed
	11		

Is the inspection result normal?

- YES >> Replace power window main switch. Refer to [PWC-112. "Removal and Installation"](#).  
 NO >> Repair or replace harness.

A  
B  
C  
D  
E  
F  
G  
H  
I  
J  
L  
M  
N  
O  
P

PWC

# POWER WINDOW MOTOR

< DTC/CIRCUIT DIAGNOSIS >

## PASSENGER SIDE

### PASSENGER SIDE : Description

INFOID:000000009950871

Door glass moves UP/DOWN by receiving the signal from power window main switch or front power window switch (passenger side).

### PASSENGER SIDE : Component Function Check

INFOID:000000009950872

#### 1. CHECK FRONT POWER WINDOW MOTOR (PASSENGER SIDE) OPERATION

Check front power window motor (passenger side) operation with power window main switch or front power window switch (passenger side).

Is the inspection result normal?

- YES >> Power window motor (passenger side) is OK.  
 NO >> Refer to [PWC-24. "PASSENGER SIDE : Diagnosis Procedure"](#).

### PASSENGER SIDE : Diagnosis Procedure

INFOID:000000009950873

#### 1. CHECK FRONT POWER WINDOW MOTOR (PASSENGER SIDE) INPUT SIGNAL

1. Turn ignition switch OFF.
2. Disconnect front power window motor (passenger side) connector.
3. Turn ignition switch ON.
4. Check voltage between front power window motor (passenger side) harness connector and ground.

(+)		(-)	Condition	Voltage (V) (Approx.)
Connector	Terminal			
D27	2	Ground	UP	Battery voltage
			DOWN	0
	1		UP	0
			DOWN	Battery voltage

Is the inspection result normal?

- YES >> Replace front power window motor (passenger side). Refer to [GW-21. "Removal and Installation"](#).  
 NO >> GO TO 2.

#### 2. CHECK FRONT POWER WINDOW MOTOR (PASSENGER SIDE) CIRCUIT

1. Turn ignition switch OFF.
2. Disconnect front power window switch (passenger side) connector.
3. Check continuity between front power window switch (passenger side) harness connector and front power window motor (passenger side) harness connector.

Front power window switch (passenger side)		Front power window motor (passenger side)		Continuity
Connector	Terminal	Connector	Terminal	
D25	6	D27	1	Existed
	7		2	

4. Check continuity between front power window switch (passenger side) harness connector and ground.

Front power window switch (passenger side)		Ground	Continuity
Connector	Terminal		
D25	6		Not existed
	7		

Is the inspection result normal?

- YES >> Replace front power window switch (passenger side). [PWC-112. "Removal and Installation"](#).



# POWER WINDOW MOTOR

## < DTC/CIRCUIT DIAGNOSIS >

NO >> Repair or replace harness.

### REAR LH

#### REAR LH : Description

INFOID:000000009950874

Door glass moves UP/DOWN by receiving the signal from power window main switch or rear power window switch LH.

#### REAR LH : Component Function Check

INFOID:000000009950875

#### 1.CHECK REAR POWER WINDOW MOTOR LH OPERATION

Check rear power window motor LH operation with power window main switch or rear power window switch LH.

Is the inspection result normal?

YES >> Rear power window motor LH is OK.

NO >> Refer to [PWC-25. "REAR LH : Diagnosis Procedure"](#)

#### REAR LH : Diagnosis Procedure

INFOID:000000009950876

#### 1.CHECK REAR POWER WINDOW MOTOR LH INPUT SIGNAL

1. Turn ignition switch OFF.
2. Disconnect rear power window motor LH connector.
3. Turn ignition switch ON.
4. Check voltage between rear power window motor LH harness connector and ground.

(+)		(-)	Condition	Voltage (V) (Approx.)
Connector	Terminal			
D67	1	Ground	UP	Battery voltage
			DOWN	0
	2		UP	0
			DOWN	Battery voltage

Is the inspection result normal?

YES >> Replace rear power window motor LH. Refer to [GW-25. "Removal and Installation"](#).

NO >> GO TO 2.

#### 2.CHECK REAR POWER WINDOW MOTOR LH CIRCUIT

1. Turn ignition switch OFF.
2. Disconnect rear power window switch LH connector.
3. Check continuity between rear power window switch LH harness connector and rear power window motor LH harness connector.

Rear power window switch LH		Rear power window motor LH		Continuity
Connector	Terminal	Connector	Terminal	
D63	4	D67	2	Existed
	5		1	

4. Check continuity between rear power window switch LH connector and ground.

Rear power window switch LH		Ground	Continuity
Connector	Terminal		
D63	4		Not existed
	5		

Is the inspection result normal?

A  
B  
C  
D  
E  
F  
G  
H  
I  
J  
L  
M  
N  
O  
P

PWC

# POWER WINDOW MOTOR

## < DTC/CIRCUIT DIAGNOSIS >

- YES >> Replace rear power window switch LH. Refer to [PWC-112. "Removal and Installation"](#).  
 NO >> Repair or replace harness.

## REAR RH

### REAR RH : Description

INFOID:000000009950877

Door glass moves UP/DOWN by receiving the signal from power window main switch or rear power window switch RH.

### REAR RH : Component Function Check

INFOID:000000009950878

#### 1. CHECK REAR POWER WINDOW MOTOR RH OPERATION

Check rear power window motor RH operation with power window main switch or rear power window switch RH.

##### Is the inspection result normal?

- YES >> Rear power window motor RH is OK.  
 NO >> Refer to [PWC-26. "REAR RH : Diagnosis Procedure"](#).

### REAR RH : Diagnosis Procedure

INFOID:000000009950879

#### 1. CHECK REAR POWER WINDOW MOTOR RH INPUT SIGNAL

- Turn ignition switch OFF.
- Disconnect rear power window motor RH connector.
- Turn ignition switch ON.
- Check voltage between rear power window motor RH harness connector and ground.

(+)		(-)	Condition	Voltage (V) (Approx.)
Connector	Terminal			
D47	1	Ground	UP	Battery voltage
			DOWN	0
	2		UP	0
			DOWN	Battery voltage

##### Is the inspection result normal?

- YES >> Replace rear power window motor RH. Refer to [GW-25. "Removal and Installation"](#).  
 NO >> GO TO 2.

#### 2. CHECK REAR POWER WINDOW MOTOR RH CIRCUIT

- Turn ignition switch OFF.
- Disconnect rear power window switch RH connector.
- Check continuity between rear power window switch RH harness connector and rear power window motor RH harness connector.

Rear power window switch RH		Rear power window motor RH		Continuity
Connector	Terminal	Connector	Terminal	
D43	4	D47	2	Existed
	5		1	

- Check continuity between rear power window switch RH harness connector and ground.

Rear power window switch RH		Ground	Continuity
Connector	Terminal		
D43	4		Not existed
	5		

##### Is the inspection result normal?

# POWER WINDOW MOTOR

## < DTC/CIRCUIT DIAGNOSIS >

---

YES >> Replace rear power window switch RH. Refer to [PWC-112. "Removal and Installation"](#).  
NO >> Repair or replace harness.

A  
B  
C  
D  
E  
F  
G  
H  
I  
J  
PWC  
L  
M  
N  
O  
P

# ENCODER CIRCUIT

< DTC/CIRCUIT DIAGNOSIS >

## ENCODER CIRCUIT

### Description

INFOID:000000009950880

Detects condition of the front power window motor (driver side) operation and transmits to power window main switch as pulse signal.

### Component Function Check

INFOID:000000009950881

#### 1. CHECK ENCODER OPERATION

Check front driver side door glass perform AUTO open/close operation normally when power window main switch.

Is the inspection result normal?

- YES >> Encoder operation is OK.
- NO >> Refer to [PWC-28. "Diagnosis Procedure"](#)

### Diagnosis Procedure

INFOID:000000009950882

#### Encoder Circuit Check

#### 1. CHECK ENCODER OPERATION

1. Turn ignition switch ON.
2. Check signal between power window main switch harness connector and ground with oscilloscope.

(+)		(-)	Signal (Reference value)
Power window main switch			
Connector	Terminal	Ground	Refer to following signal
D5	9		
	13		

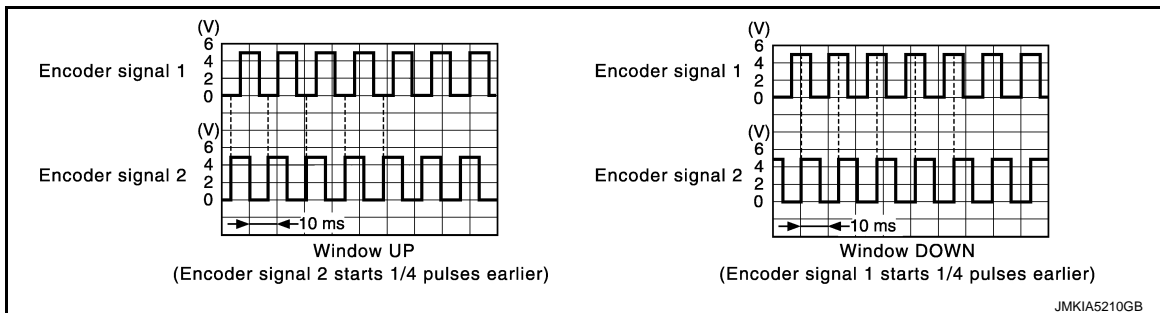

Is the inspection result normal?

- YES >> GO TO 7.
- NO >> GO TO 2.

#### 2. CHECK ENCODER SIGNAL CIRCUIT

1. Turn ignition switch OFF.
2. Disconnect power window main switch connector and front power window motor (driver side) connector.
3. Check continuity between power window main switch harness connector and front power window motor (driver side) harness connector.

Power window main switch		Front power window motor (driver side)		Continuity
Connector	Terminal	Connector	Terminal	
D5	9	D7	6	Existed
	13		5	

4. Check continuity between power window main switch harness connector and ground.

# ENCODER CIRCUIT

## < DTC/CIRCUIT DIAGNOSIS >

Power window main switch		Ground	Continuity
Connector	Terminal		Not existed
D5	9		
	13		

Is the inspection result normal?

YES >> GO TO 3.

NO >> Repair or replace harness.

### 3.CHECK ENCODER POWER SUPPLY CIRCUIT

1. Connect power window main switch connector.
2. Turn ignition switch ON.
3. Check voltage between front power window motor (driver side) harness connector and ground.

(+)		(-)	Voltage (V) (Approx.)
Front power window motor (driver side)			
Connector	Terminal		
D7	2	Ground	Battery voltage

Is the inspection result normal?

YES >> GO TO 4.

NO >> GO TO 5.

### 4.CHECK GROUND CIRCUIT

1. Turn ignition switch OFF.
2. Check continuity between front power window motor (driver side) harness connector and ground.

Front power window motor (driver side)		Ground	Continuity
Connector	Terminal		Existed
D7	4		

Is the inspection result normal?

YES >> GO TO 7.

NO >> GO TO 6.

### 5.CHECK HARNESS CONTINUITY 1

1. Turn ignition switch OFF.
2. Check continuity between power window main switch harness connector and front power window motor (driver side) harness connector.

Power window main switch		Front power window motor (driver side)		Continuity
Connector	Terminal	Connector	Terminal	
D5	15	D7	2	Existed

3. Check continuity between power window main switch harness connector and ground.

Power window main switch		Ground	Continuity
Connector	Terminal		Not existed
D5	15		

Is the inspection result normal?

YES >> Replace power window main switch. Refer to [PWC-112, "Removal and Installation"](#).

NO >> Repair or replace harness.

### 6.CHECK HARNESS CONTINUITY 2

1. Disconnect power window main switch connector.

A  
B  
C  
D  
E  
F  
G  
H  
I  
J  
L  
M  
N  
O  
P

PWC

## ENCODER CIRCUIT

### < DTC/CIRCUIT DIAGNOSIS >

2. Check continuity between power window main switch harness connector and front power window motor (driver side) harness connector.

Power window main switch		Front power window motor (driver side)		Continuity
Connector	Terminal	Connector	Terminal	
D5	2	D7	4	Existed

Is the inspection result normal?

- YES >> Replace power window main switch. Refer to [PWC-112, "Removal and Installation"](#).  
NO >> Repair or replace harness.

### 7. CHECK INTERMITTENT INCIDENT

Refer to [GI-40, "Intermittent Incident"](#).

>> INSPECTION END

## BCM (BODY CONTROL MODULE)

< ECU DIAGNOSIS INFORMATION >

### ECU DIAGNOSIS INFORMATION

BCM (BODY CONTROL MODULE)

WITH INTELLIGENT KEY

WITH INTELLIGENT KEY : Reference Value

INFOID:000000010230391

VALUES ON THE DIAGNOSIS TOOL

**NOTE:**

The following table includes information (items) inapplicable to this vehicle. For information (items) applicable to this vehicle, refer to CONSULT display items.

CONSULT MONITOR ITEM

Monitor Item	Condition	Value/Status
FR WIPER HI	Other than front wiper switch HI	Off
	Front wiper switch HI	On
FR WIPER LOW	Other than front wiper switch LO	Off
	Front wiper switch LO	On
FR WASHER SW	Front washer switch OFF	Off
	Front washer switch ON	On
FR WIPER INT	Other than front wiper switch INT	Off
	Front wiper switch INT	On
FR WIPER STOP	Front wiper is not in STOP position	Off
	Front wiper is in STOP position	On
INT VOLUME	Wiper intermittent dial is in a dial position 1 - 7	Wiper intermittent dial position
RR WIPER ON	Other than rear wiper switch ON	Off
	Rear wiper switch ON	On
RR WIPER INT	Other than rear wiper switch INT	Off
	Rear wiper switch INT	On
RR WASHER SW	Rear washer switch OFF	Off
	Rear washer switch ON	On
RR WIPER STOP	Rear wiper is in STOP position	Off
	Rear wiper is not in STOP position	On
TURN SIGNAL R	Other than turn signal switch RH	Off
	Turn signal switch RH	On
TURN SIGNAL L	Other than turn signal switch LH	Off
	Turn signal switch LH	On
TAIL LAMP SW	Other than lighting switch 1ST and 2ND	Off
	Lighting switch 1ST or 2ND	On
HI BEAM SW	Other than lighting switch HI	Off
	Lighting switch HI	On
HEAD LAMP SW 1	Other than lighting switch 2ND	Off
	Lighting switch 2ND	On
HEAD LAMP SW 2	Other than lighting switch 2ND	Off
	Lighting switch 2ND	On
PASSING SW	Other than lighting switch PASS	Off
	Lighting switch PASS	On

A  
B  
C  
D  
E  
F  
G  
H  
I  
J  
L  
M  
N  
O  
P

PWC

## BCM (BODY CONTROL MODULE)

### < ECU DIAGNOSIS INFORMATION >

Monitor Item	Condition	Value/Status
AUTO LIGHT SW	Other than lighting switch AUTO	Off
	Lighting switch AUTO	On
FR FOG SW	Front fog lamp switch OFF	Off
	Front fog lamp switch ON	On
DOOR SW-DR	Driver door closed	Off
	Driver door opened	On
DOOR SW-AS	Passenger door closed	Off
	Passenger door opened	On
DOOR SW-RR	Rear RH door closed	Off
	Rear RH door opened	On
DOOR SW-RL	Rear LH door closed	Off
	Rear LH door opened	On
DOOR SW-BK	Back door closed	Off
	Back door opened	On
CDL LOCK SW	Other than power door lock switch LOCK	Off
	Power door lock switch LOCK	On
CDL UNLOCK SW	Other than power door lock switch UNLOCK	Off
	Power door lock switch UNLOCK	On
KEY CYL LK-SW	Other than driver door key cylinder LOCK position	Off
	Driver door key cylinder LOCK position	On
KEY CYL UN-SW	Other than driver door key cylinder UNLOCK position	Off
	Driver door key cylinder UNLOCK position	On
HAZARD SW	Hazard switch is OFF	Off
	Hazard switch is ON	On
REAR DEF SW	Rear window defogger switch OFF	Off
	Rear window defogger switch ON	On
TR/BD OPEN SW	<b>NOTE:</b> The item is indicated, but not monitored.	Off
TRNK/HAT MNTR	<b>NOTE:</b> The item is indicated, but not monitored.	Off
FAN ON SIG	Blower fan OFF	Off
	Blower fan ON	On
AIR COND SW	Air conditioner OFF (A/C switch indicator OFF)	Off
	Air conditioner ON (A/C switch indicator ON)	On
RKE-LOCK	LOCK button of the key is not pressed	Off
	LOCK button of the key is pressed	On
RKE-UNLOCK	UNLOCK button of the key is not pressed	Off
	UNLOCK button of the key is pressed	On
RKE-TR/BD	BACK DOOR OPEN button of the key is not pressed	Off
	BACK DOOR OPEN button of the key is pressed	On
RKE-PANIC	PANIC button of the key is not pressed	Off
	PANIC button of the key is pressed	On
RKE-MODE CHG	LOCK/UNLOCK button of the key is not pressed and held simultaneously	Off
	LOCK/UNLOCK button of the key is pressed and held simultaneously	On



## BCM (BODY CONTROL MODULE)

### < ECU DIAGNOSIS INFORMATION >

Monitor Item	Condition	Value/Status	
OPTI SEN (DTCT)	Bright outside of the vehicle	Close to 5 V	A
	Dark outside of the vehicle	Close to 0 V	
OPTI SEN (FILT)	Bright outside of the vehicle (Lighting switch AUTO)	Close to 5 V	B
	Dark outside of the vehicle (Lighting switch AUTO)	Close to 1.50 V	
OPTICAL SENSOR	<b>NOTE:</b> The item is indicated, but not monitored.	Off	C
RAIN SENSOR	<b>NOTE:</b> The item is indicated, but not monitored.	Off	
REQ SW -DR	Driver door request switch is not pressed	Off	D
	Driver door request switch is pressed	On	
REQ SW -AS	Passenger door request switch is not pressed	Off	E
	Passenger door request switch is pressed	On	
REQ SW -RR	<b>NOTE:</b> The item is indicated, but not monitored.	Off	F
REQ SW -RL	<b>NOTE:</b> The item is indicated, but not monitored.	Off	
REQ SW -BD/TR	Back door request switch is not pressed	Off	G
	Back door request switch is pressed	On	
PUSH SW	Push-button ignition switch (push switch) is not pressed	Off	H
	Push-button ignition switch (push switch) is pressed	On	
CLUCH SW	The clutch pedal is not depressed.	Off	I
	The clutch pedal is depressed	On	
BRAKE SW 1	The brake pedal is not depressed	Off	J
	The brake pedal is depressed	On	
BRAKE SW 2	The brake pedal is depressed when No. 9 fuse is blown	Off	
	The brake pedal is not depressed when No. 9 fuse is blown, or No. 9 fuse is normal	On	
DETE/CANCL SW	Selector lever in P position	Off	PWC
	Selector lever in any position other than P	On	
SFT PN/N SW	Selector lever in any position other than P and N	Off	L
	Selector lever in P or N position	On	
S/L -LOCK	<b>NOTE:</b> The item is indicated, but not monitored.	Off	M
S/L -UNLOCK	<b>NOTE:</b> The item is indicated, but not monitored.	Off	
S/L RELAY-F/B	<b>NOTE:</b> The item is indicated, but not monitored.	Off	N
UNLK SEN -DR	Driver door is locked	Off	O
	Driver door is unlocked	On	
PUSH SW -IPDM	Push-button ignition switch (push-switch) is not pressed	Off	P
	Push-button ignition switch (push-switch) is pressed	On	
IGN RLY1 -F/B	Ignition switch in OFF or ACC position	Off	
	Ignition switch in ON position	On	
DETE SW -IPDM	Selector lever in any position other than P	Off	
	Selector lever in P position	On	
SFT PN -IPDM	Selector lever in any position other than P and N	Off	
	Selector lever in P or N position	On	

## BCM (BODY CONTROL MODULE)

### < ECU DIAGNOSIS INFORMATION >

Monitor Item	Condition	Value/Status
SFT P -MET	Selector lever in any position other than P	Off
	Selector lever in P position	On
SFT N -MET	Selector lever in any position other than N	Off
	Selector lever in N position	On
ENGINE STATE	Engine stopped	Stop
	While the engine stalls	Stall
	At engine cranking	Crank
	Engine running	Run
S/L LOCK-IPDM	<b>NOTE:</b> The item is indicated, but not monitored.	Off
S/L UNLK-IPDM	<b>NOTE:</b> The item is indicated, but not monitored.	Off
S/L RELAY-REQ	<b>NOTE:</b> The item is indicated, but not monitored.	Off
VEH SPEED 1	While driving	Equivalent to speedometer reading
VEH SPEED 2	While driving	Equivalent to speedometer reading
DOOR STAT-DR	Driver door is locked	LOCK
	Wait with selective UNLOCK operation (5 seconds)	READY
	Driver door is unlocked	UNLOCK
DOOR STAT-AS	Passenger door is locked	LOCK
	Wait with selective UNLOCK operation (5 seconds)	READY
	Passenger door is unlocked	UNLOCK
ID OK FLAG	Driver side door is open after ignition switch is turned OFF (Selector lever is in the P position except for M/T models)	Reset
	Ignition switch ON	Set
PRMT ENG STRT	The engine start is prohibited	Reset
	The engine start is permitted	Set
PRMT RKE STRT	<b>NOTE:</b> The item is indicated, but not monitored.	Reset
RKE OPE COUN1	During the operation of the key	Operation frequency of the key
RKE OPE COUN2	<b>NOTE:</b> The item is indicated, but not monitored.	—
CONFIRM ID ALL	The key ID that the key slot receives is not recognized by any key ID registered to BCM.	Yet
	The key ID that the key slot receives is recognized by any key ID registered to BCM.	Done
CONFIRM ID4	The key ID that the key slot receives is not recognized by the fourth key ID registered to BCM.	Yet
	The key ID that the key slot receives is recognized by the fourth key ID registered to BCM.	Done
CONFIRM ID3	The key ID that the key slot receives is not recognized by the third key ID registered to BCM.	Yet
	The key ID that the key slot receives is recognized by the third key ID registered to BCM.	Done

## BCM (BODY CONTROL MODULE)

### < ECU DIAGNOSIS INFORMATION >

Monitor Item	Condition	Value/Status	
CONFIRM ID2	The key ID that the key slot receives is not recognized by the second key ID registered to BCM.	Yet	A
	The key ID that the key slot receives is recognized by the second key ID registered to BCM.	Done	B
CONFIRM ID1	The key ID that the key slot receives is not recognized by the first key ID registered to BCM.	Yet	C
	The key ID that the key slot receives is recognized by the first key ID registered to BCM.	Done	
NOT REGISTERED	BCM detects registered key ID, or BCM does not detect key ID.	ID OK	D
	BCM detects non-registration key ID.	ID NG	
TP 4	The ID of fourth key is not registered to BCM	Yet	E
	The ID of fourth key is registered to BCM	Done	
TP 3	The ID of third key is not registered to BCM	Yet	F
	The ID of third key is registered to BCM	Done	
TP 2	The ID of second key is not registered to BCM	Yet	G
	The ID of second key is registered to BCM	Done	
TP 1	The ID of first key is not registered to BCM	Yet	H
	The ID of first key is registered to BCM	Done	
AIR PRESS FL	Ignition switch ON (Only when the signal from the transmitter is received)	Air pressure of front LH tire	I
AIR PRESS FR	Ignition switch ON (Only when the signal from the transmitter is received)	Air pressure of front RH tire	J
AIR PRESS RR	Ignition switch ON (Only when the signal from the transmitter is received)	Air pressure of rear RH tire	
AIR PRESS RL	Ignition switch ON (Only when the signal from the transmitter is received)	Air pressure of rear LH tire	
ID REGST FL1	ID of front LH tire transmitter is registered	Done	
	ID of front LH tire transmitter is not registered	Yet	
ID REGST FR1	ID of front RH tire transmitter is registered	Done	PWC
	ID of front RH tire transmitter is not registered	Yet	
ID REGST RR1	ID of rear RH tire transmitter is registered	Done	L
	ID of rear RH tire transmitter is not registered	Yet	
ID REGST RL1	ID of rear LH tire transmitter is registered	Done	M
	ID of rear LH tire transmitter is not registered	Yet	
WARNING LAMP	Tire pressure indicator OFF	Off	N
	Tire pressure indicator ON	On	
BUZZER	Tire pressure warning alarm is not sounding	Off	O
	Tire pressure warning alarm is sounding	On	P

# BCM (BODY CONTROL MODULE)

< ECU DIAGNOSIS INFORMATION >

## TERMINAL LAYOUT

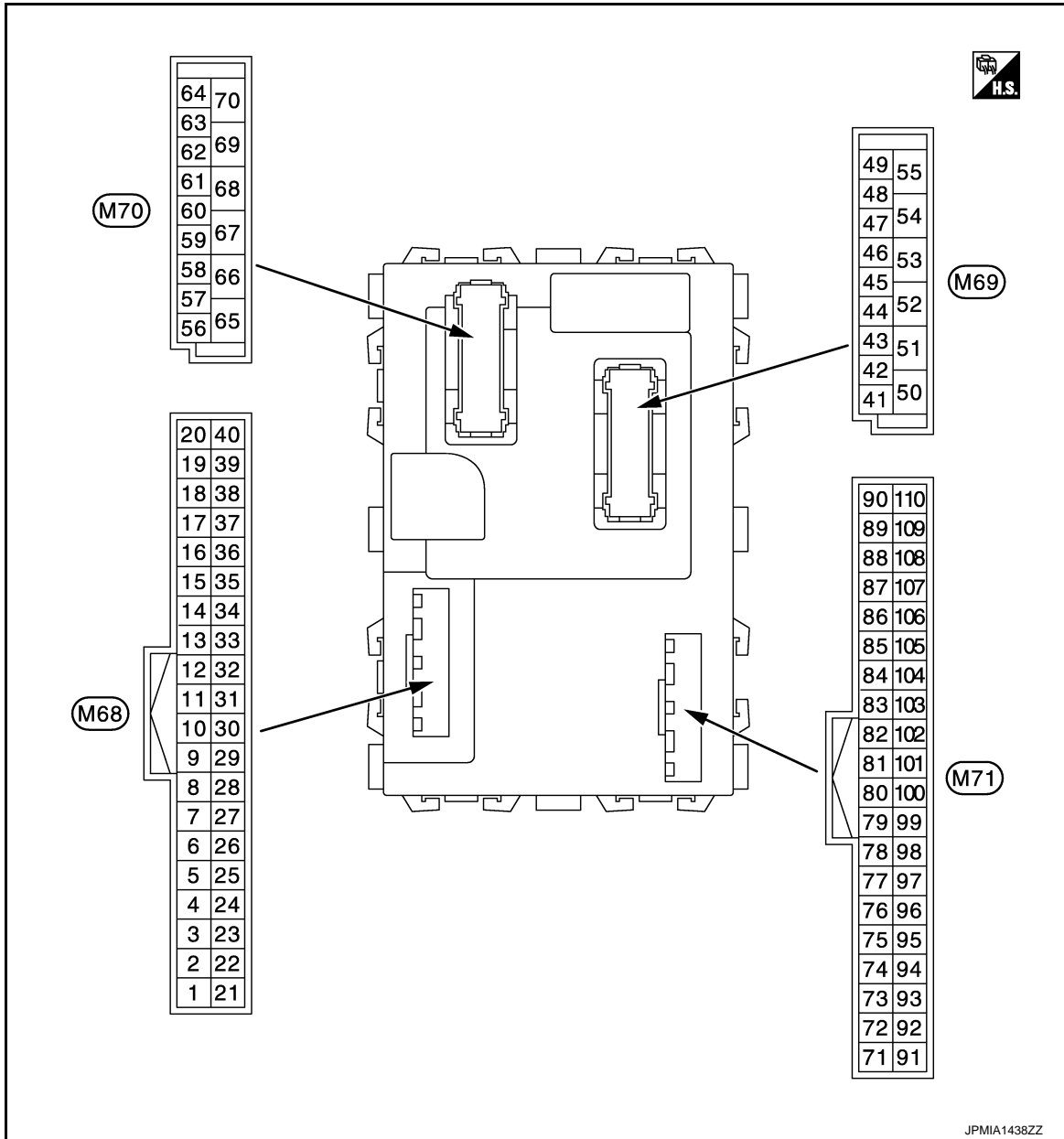

**NOTE:**

- Connector color
- M68, M70: Black
- M69, M71: White

**PHYSICAL VALUES**

# BCM (BODY CONTROL MODULE)

< ECU DIAGNOSIS INFORMATION >

Terminal No. (Wire color)		Description		Condition	Value (Approx.)	
+	-	Signal name	Input/ Output			
2 (BR/W)	Ground	Combination switch INPUT 5	Input	Combination switch (Wiper intermit- tent dial 4)	All switch OFF	0 V
					Turn signal switch RH	
					Lighting switch HI	
					Lighting switch 1ST	
					Lighting switch 2ND	
3 (GR)	Ground	Combination switch INPUT 4	Input	Combination switch (Wiper intermit- tent dial 4)	All switch OFF	0 V
					Turn signal switch LH	
					Lighting switch PASS	
					Lighting switch 2ND	
					Front fog lamp switch ON	
4 (L/Y)	Ground	Combination switch INPUT 3	Input	Combination switch (Wiper intermit- tent dial 4)	All switch OFF	0 V
					Front wiper switch LO	
					Front wiper switch MIST	
					Front wiper switch INT	
					Lighting switch AUTO	

A  
B  
C  
D  
E  
F  
G  
H  
I  
J  
L  
M  
N  
O  
P

PWC

# BCM (BODY CONTROL MODULE)

## < ECU DIAGNOSIS INFORMATION >

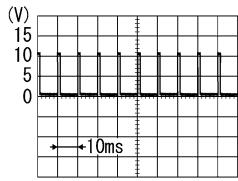
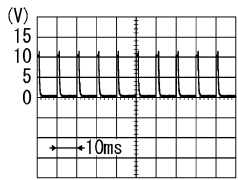
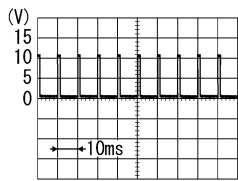
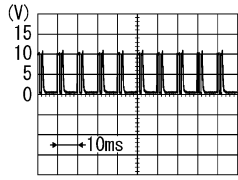
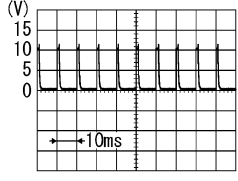
Terminal No. (Wire color)		Description		Condition	Value (Approx.)	
+	-	Signal name	Input/ Output			
5 (G)	Ground	Combination switch INPUT 2	Input	Combination switch	All switch OFF (Wiper intermittent dial 4)	0 V
					Front washer switch (Wiper intermittent dial 4)	
					Rear washer ON (Wiper intermittent dial 4)	
					Any of the condition below with all switch OFF <ul style="list-style-type: none"> <li>• Wiper intermittent dial 1</li> <li>• Wiper intermittent dial 5</li> <li>• Wiper intermittent dial 6</li> </ul>	
Rear wiper switch ON (Wiper intermittent dial 4)		0.8 V				
6 (L/R)	Ground	Combination switch INPUT 1	Input	Combination switch	All switch OFF (Wiper intermittent dial 4)	0 V
					Front wiper switch HI (Wiper intermittent dial 4)	
					Rear wiper switch INT (Wiper intermittent dial 4)	
					Wiper intermittent dial 3 (All switch OFF)	
					Any of the condition below with all switch OFF <ul style="list-style-type: none"> <li>• Wiper intermittent dial 1</li> <li>• Wiper intermittent dial 2</li> </ul>	
Any of the condition below with all switch OFF <ul style="list-style-type: none"> <li>• Wiper intermittent dial 6</li> <li>• Wiper intermittent dial 7</li> </ul>		0.8 V				

# BCM (BODY CONTROL MODULE)

## < ECU DIAGNOSIS INFORMATION >

Terminal No. (Wire color)		Description		Condition	Value (Approx.)
+	-	Signal name	Input/ Output		
7 (W/R)	Ground	Door key cylinder switch UNLOCK	Input	Door key cylinder switch	NEUTRAL position
				UNLOCK position	8.0 - 8.5 V
8 (W/B)	Ground	Door key cylinder switch LOCK	Input	Door key cylinder switch	NEUTRAL position
				LOCK position	0 V
9 (R)	Ground	Stop lamp switch 1	Input	Stop lamp switch	OFF (Brake pedal is not depressed)
				ON (Brake pedal is de- pressed)	Battery voltage
12 (GR)	Ground	Door lock and unlock switch LOCK	Input	Door lock and unlock switch	NEUTRAL position
				LOCK position	0 V
13 (BR)	Ground	Door lock and unlock switch UNLOCK	Input	Door lock and unlock switch	NEUTRAL position
				UNLOCK position	0 V
14 (L/G)	Ground	Optical sensor	Input	Ignition switch ON	When bright outside of the vehicle
				When dark outside of the vehicle	Close to 0 V
15 (W/L)	Ground	Rear window defog- ger switch	Input	Rear window defogger switch	Not pressed
				Pressed	0 V
17 (R/G)	Ground	Optical sensor pow- er supply	Output	Ignition switch	OFF, ACC
				ON	5 V

A  
B  
C  
D  
E  
F  
G  
H  
I  
J  
L  
M  
N  
O  
P

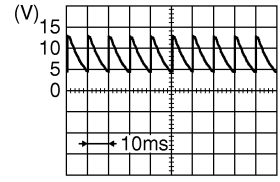

JPMIA0587GB  
8.0 - 8.5 V

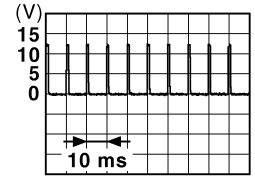

JPMIA0012GB  
1.0 - 1.5 V

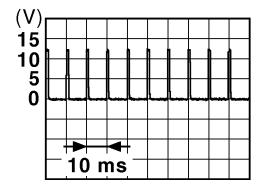

JPMIA0012GB  
1.0 - 1.5 V

PWC

# BCM (BODY CONTROL MODULE)

## < ECU DIAGNOSIS INFORMATION >

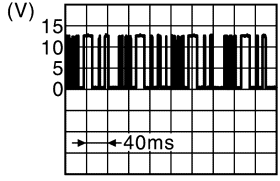
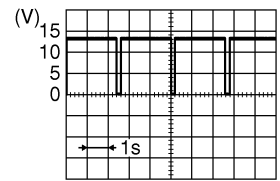
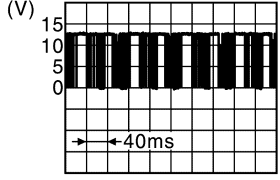
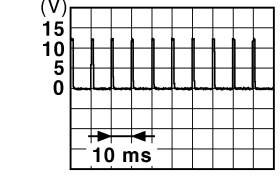
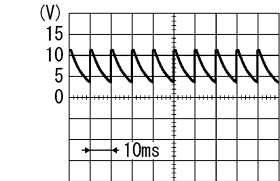
Terminal No. (Wire color)		Description		Condition	Value (Approx.)
+	-	Signal name	Input/ Output		
18 (V)	Ground	Sensor ground	Input	Ignition switch ON	0 V
21 (P/L)	Ground	NATS antenna amp.	Input/ Output	Intelligent Key: Intelligent Key battery is re- moved	Brake pedal: Depressed <b>NOTE:</b> Waveform varies each time when brake pedal is depressed  <small>JMKIA6232JP</small>
				Brake pedal: Not de- pressed	12 V
23 (R/Y)	Ground	Security indicator lamp	Output	ON	0 V
				Security indica- tor	Blinking (Ignition switch OFF)  <small>JPMIA0590GB</small>
25 (LG)	Ground	NATS antenna amp.	Input/ Output	During waiting	Brake pedal: Depressed <b>NOTE:</b> Waveform varies each time when brake pedal is depressed  <small>JMKIA6233JP</small>
				Brake pedal: Not de- pressed	12 V
27 (O)	Ground	A/C ON	Input	A/C	OFF (A/C switch indicator: OFF)  <small>JPMIA0012GB</small>
				1.0 - 1.5 V	
28 (G/W)	Ground	Blower fan switch	Input	Fan switch	Blower fan switch OFF
				Blower fan switch ON  <small>PKIB4960J</small>	
					7.0 - 8.0 V



# BCM (BODY CONTROL MODULE)

## < ECU DIAGNOSIS INFORMATION >

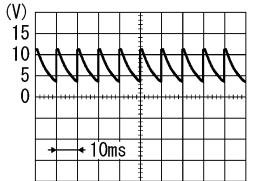
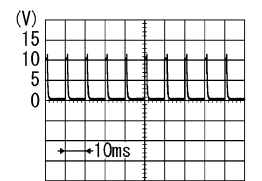
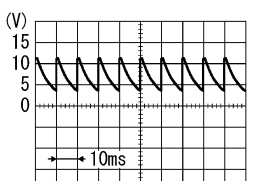
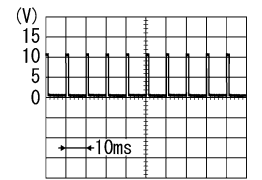
Terminal No. (Wire color)		Description		Condition	Value (Approx.)	
+	-	Signal name	Input/ Output			
29 (L/W)	Ground	Hazard switch	Input	Hazard switch	OFF ON	12 V 0 V
				31 (G/B)	Ground	Front door lock assembly driver side (Unlock sensor)
UNLOCK status (Unlock sensor switch ON)	0 V					
32 (LG)	Ground	Combination switch OUTPUT 5	Output	Combination switch	All switch OFF (Wiper intermittent dial 4)	 7.0 - 8.0 V
					Front fog lamp switch ON (Wiper intermittent dial 4)	 1.0 V
					Rear wiper switch ON (Wiper intermittent dial 4)	
Any of the condition below with all switch OFF						
<ul style="list-style-type: none"> <li>Wiper intermittent dial 1</li> <li>Wiper intermittent dial 2</li> <li>Wiper intermittent dial 6</li> <li>Wiper intermittent dial 7</li> </ul>						
33 (Y/L)	Ground	Combination switch OUTPUT 4	Output	Combination switch	All switch OFF (Wiper intermittent dial 4)	 7.0 - 8.0 V
					Lighting switch 1ST (Wiper intermittent dial 4)	 1.2 V
					Lighting switch AUTO (Wiper intermittent dial 4)	
					Rear wiper switch INT (Wiper intermittent dial 4)	
Any of the condition below with all switch OFF						
<ul style="list-style-type: none"> <li>Wiper intermittent dial 1</li> <li>Wiper intermittent dial 5</li> <li>Wiper intermittent dial 6</li> </ul>						

A  
B  
C  
D  
E  
F  
G  
H  
I  
J  
L  
M  
N  
O  
P

PWC

# BCM (BODY CONTROL MODULE)

## < ECU DIAGNOSIS INFORMATION >

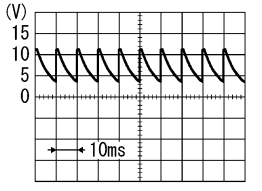
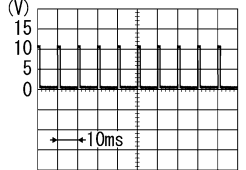
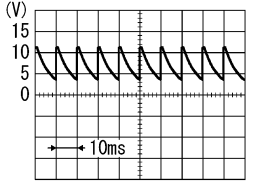
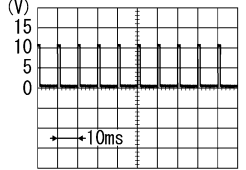
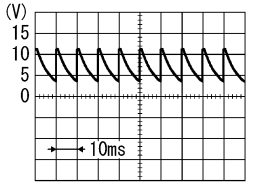
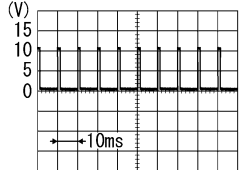
Terminal No. (Wire color)		Description		Condition	Value (Approx.)	
+	-	Signal name	Input/ Output			
34 (W)	Ground	Combination switch OUTPUT 3	Output	Combination switch	All switch OFF (Wiper intermittent dial 4)	 <p style="text-align: right;">PKIB4960J</p> <p style="text-align: center;">7.0 - 8.0 V</p>
					Lighting switch 2ND (Wiper intermittent dial 4)	 <p style="text-align: right;">PKIB4958J</p> <p style="text-align: center;">1.2 V</p>
					Lighting switch HI (Wiper intermittent dial 4)	
					Rear washer switch ON (Wiper intermittent dial 4)	
Any of the condition below with all switch OFF						
<ul style="list-style-type: none"> <li>• Wiper intermittent dial 1</li> <li>• Wiper intermittent dial 2</li> <li>• Wiper intermittent dial 3</li> </ul>						
35 (R/L)	Ground	Combination switch OUTPUT 2	Output	Combination switch (Wiper intermit- tent dial 4)	All switch OFF	 <p style="text-align: right;">PKIB4960J</p> <p style="text-align: center;">7.0 - 8.0 V</p>
					Lighting switch 2ND	 <p style="text-align: right;">PKIB4958J</p> <p style="text-align: center;">1.2 V</p>
					Lighting switch PASS	
					Front wiper switch INT	
Front wiper switch HI						
36 (L/O)	Ground	Combination switch OUTPUT 1	Output	Combination switch (Wiper intermit- tent dial 4)	All switch OFF	 <p style="text-align: right;">PKIB4960J</p> <p style="text-align: center;">7.0 - 8.0 V</p>
					Turn signal switch RH	 <p style="text-align: right;">PKIB4958J</p> <p style="text-align: center;">1.2 V</p>
					Turn signal switch LH	
					Front wiper switch LO (Front wiper switch MIST)	
Front washer switch ON						

# BCM (BODY CONTROL MODULE)

## < ECU DIAGNOSIS INFORMATION >

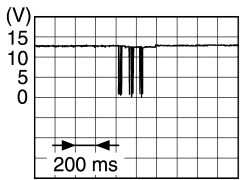
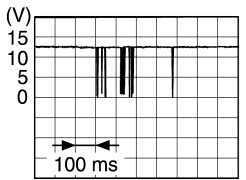
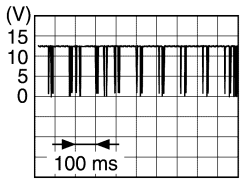
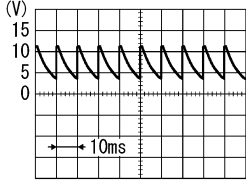
Terminal No. (Wire color)		Description		Condition		Value (Approx.)
+	-	Signal name	Input/ Output			
37 (G/O)	Ground	Selector lever P position switch	Input	Selector lever	P position	0 V
					Any position other than P	12 V
38 (G/Y)	Ground	Receiver communication	Input/ Output	Ignition switch OFF (Remote keyless entry communication)	Waiting	12 V
					When operating either button on Intelligent Key	 <small>JMMIA0572GB</small>
				Ignition switch ON (TPMS communication)	Waiting	 <small>JMMIA0573GB</small>
					When receiving signal from tire pressure sensor	 <small>JMMIA0574GB</small>
39 (L)	Ground	CAN-H	Input/ Output	—	—	
40 (P)	Ground	CAN-L	Input/ Output	—	—	
43 (W)	Ground	Back door switch	Input	Back door switch	OFF (When back door closed)	 <small>PKIB4960J</small> 9.5 - 10.0 V
					ON (When back door opened)	0 V
44 (LG)	Ground	Rear wiper stop position	Input	Ignition switch ON	Rear wiper stop position	12 V
					Any position other than rear wiper stop position	0 V

A  
B  
C  
D  
E  
F  
G  
H  
I  
J  
L  
M  
N  
O  
P

PWC

# BCM (BODY CONTROL MODULE)

## < ECU DIAGNOSIS INFORMATION >

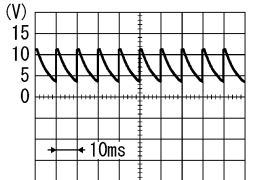
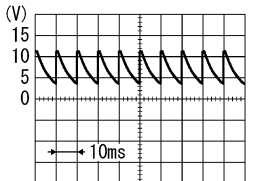
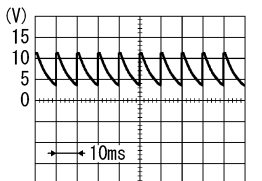
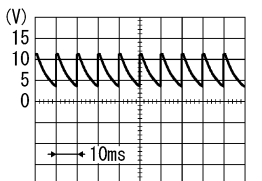
Terminal No. (Wire color)		Description		Condition	Value (Approx.)	
+	-	Signal name	Input/ Output			
45 (SB)	Ground	Passenger door switch	Input	Passenger door switch	OFF (When passenger door closed)	 <small>PKIB4960J</small> 7.0 - 8.0 V
				Passenger door switch	ON (When passenger door opened)	0 V
46 (GR/L)	Ground	Rear RH door switch	Input	Rear RH door switch	OFF (When rear RH door closed)	 <small>PKIB4960J</small> 7.0 - 8.0 V
				Rear RH door switch	ON (When rear RH door opened)	0 V
47 (BR/Y)	Ground	Driver door switch	Input	Driver door switch	OFF (When driver door closed)	 <small>PKIB4960J</small> 7.0 - 8.0 V
				Driver door switch	ON (When driver door opened)	0 V
48 (W/G)	Ground	Rear LH door switch	Input	Rear LH door switch	OFF (When rear LH door closed)	 <small>PKIB4960J</small> 7.0 - 8.0 V
				Rear LH door switch	ON (When rear door LH opened)	0 V
50 (R/W)	Ground	Back door lock actuator relay control	Output	Back door	LOCK (Actuator is activated)	0 V
					Back door	Other than LOCK (Actuator is not activated)
51 (W)	Ground	Back door request switch	Input	Back door request switch	ON (Pressed)	0 V
					Back door request switch	OFF (Not pressed)
54 (LG)	Ground	Rear wiper	Output	Rear wiper	OFF (Stopped)	0 V
					Rear wiper	ON (Activated)

# BCM (BODY CONTROL MODULE)

## < ECU DIAGNOSIS INFORMATION >

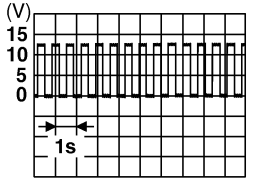
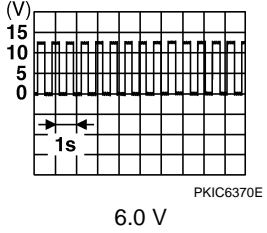
Terminal No. (Wire color)		Description		Condition		Value (Approx.)
		Signal name	Input/ Output			
+	-					
55 (G)	Ground	Rear door UNLOCK	Output	Rear door	UNLOCK (Actuator is activated)	12 V
					Other than UNLOCK (Actuator is not activated)	0 V
56 (L)	Ground	Interior room lamp power supply	Output		Interior room lamp battery saver is activated. (Cuts the interior room lamp power supply)	0 V
					Interior room lamp battery saver is not activated. (Outputs the interior room lamp power supply)	12 V
57 (Y)	Ground	Battery power supply	Input	Ignition switch OFF		Battery voltage
59 (G)	Ground	Passenger door UNLOCK	Output	Passenger door	UNLOCK (Actuator is activated)	12 V
					Other than UNLOCK (Actuator is not activated)	0 V
60 (W/B)	Ground	Turn signal LH	Output	Ignition switch ON	Turn signal switch OFF	0 V
					Turn signal switch LH	 <p style="text-align: center;">6.0 V</p>
61 (W/L)	Ground	Turn signal RH	Output	Ignition switch ON	Turn signal switch OFF	0 V
					Turn signal switch RH	 <p style="text-align: center;">6.0 V</p>
63 (BR)	Ground	Interior room lamp control signal	Output	Interior room lamp	OFF	12 V
					ON	0 V
65 (V)	Ground	All doors LOCK	Output	All doors	LOCK (Actuator is activated)	12 V
					Other than LOCK (Actuator is not activated)	0 V
66 (L/B)	Ground	Driver door UNLOCK	Output	Driver door	UNLOCK (Actuator is activated)	12 V
					Other than UNLOCK (Actuator is not activated)	0 V
67 (B)	Ground	Ground	Output	Ignition switch ON		0 V
68 (L)	Ground	P/W power supply (IGN)	Output	Ignition switch ON		12 V
69 (P)	Ground	P/W power supply (BAT)	Output	Ignition switch OFF		12 V

A  
B  
C  
D  
E  
F  
G  
H  
I  
J  
L  
M  
N  
O  
P

PWC

# BCM (BODY CONTROL MODULE)

## < ECU DIAGNOSIS INFORMATION >

Terminal No. (Wire color)		Description		Condition	Value (Approx.)	
+	-	Signal name	Input/ Output			
70 (Y)	Ground	Battery power supply	Input	Ignition switch OFF	Battery voltage	
72 (SB)	Ground	A/C indicator	Output	A/C indicator	OFF	12 V
					ON	0 V
75 (SB)	Ground	Driver door request switch	Input	Driver door request switch	ON (Pressed)	0 V
					OFF (Not pressed)	12 V
76 (L/O)	Ground	Push-button ignition switch (push switch)	Input	Push-button ignition switch (push switch)	Pressed	0 V
					Not pressed	12 V
78 (LG)	Ground	Driver door antenna (+)	Output	When the driver door request switch is operated with ignition switch ON	When Intelligent Key is not in the antenna detection area (The distance between Intelligent Key and antenna: Approx. 2 m)	<p style="text-align: right; font-size: small;">JMKIA5954GB</p>
					When Intelligent Key is in the antenna detection area (The distance between Intelligent Key and antenna: 80 cm or less)	<p style="text-align: right; font-size: small;">JMKIA5955GB</p>
79 (V)	Ground	Driver door antenna (-)	Output	When the driver door request switch is operated with ignition switch ON	When Intelligent Key is not in the antenna detection area (The distance between Intelligent Key and antenna: Approx. 2 m)	<p style="text-align: right; font-size: small;">JMKIA5954GB</p>
					When Intelligent Key is in the antenna detection area (The distance between Intelligent Key and antenna: 80 cm or less)	<p style="text-align: right; font-size: small;">JMKIA5955GB</p>

# BCM (BODY CONTROL MODULE)

## < ECU DIAGNOSIS INFORMATION >

Terminal No. (Wire color)		Description		Condition	Value (Approx.)
+	-	Signal name	Input/ Output		
80 (BR/Y)	Ground	Passenger door antenna (+)	Output	When Intelligent Key is not in the antenna detection area (The distance between Intelligent Key and antenna: Approx. 2 m)	<p style="text-align: right; font-size: small;">JMKIA5954GB</p>
				When the passenger door request switch is operated with ignition switch ON	<p style="text-align: right; font-size: small;">JMKIA5955GB</p>
81 (L/Y)	Ground	Passenger door antenna (-)	Output	When Intelligent Key is not in the antenna detection area (The distance between Intelligent Key and antenna: Approx. 2 m)	<p style="text-align: right; font-size: small;">JMKIA5954GB</p>
				When the passenger door request switch is operated with ignition switch ON	<p style="text-align: right; font-size: small;">JMKIA5955GB</p>
82 (W/B)	Ground	Back door antenna (+)	Output	When Intelligent Key is not in the antenna detection area (The distance between Intelligent Key and antenna: Approx. 2 m)	<p style="text-align: right; font-size: small;">JMKIA5954GB</p>
				When the back door request switch is operated with ignition switch ON	<p style="text-align: right; font-size: small;">JMKIA5955GB</p>

A  
B  
C  
D  
E  
F  
G  
H  
I  
J  
L  
M  
N  
O  
P

PWC

# BCM (BODY CONTROL MODULE)

## < ECU DIAGNOSIS INFORMATION >

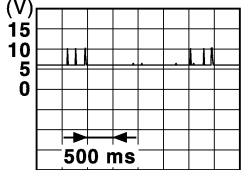
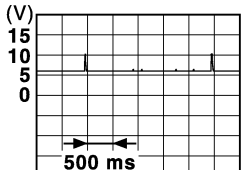
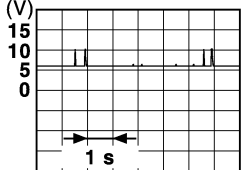
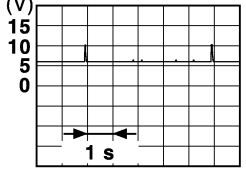
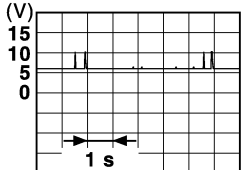
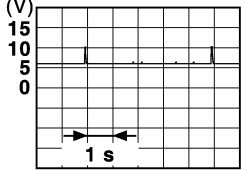
Terminal No. (Wire color)		Description		Condition	Value (Approx.)
+	-	Signal name	Input/ Output		
83 (B/W)	Ground	Back door antenna (-)	Output	When the back door request switch is operated with ignition switch ON	<p>When Intelligent Key is not in the antenna detection area (The distance between Intelligent Key and antenna: Approx. 2 m)</p>  <p style="text-align: right; font-size: small;">JMKIA5954GB</p>
				When Intelligent Key is in the antenna detection area (The distance between Intelligent Key and antenna: 80 cm or less)	 <p style="text-align: right; font-size: small;">JMKIA5955GB</p>
84 (Y/G)	Ground	Room antenna (+) (Instrument center)	Output	Ignition switch ON	<p>When Intelligent Key is not in the antenna detection area</p>  <p style="text-align: right; font-size: small;">JMKIA5951GB</p>
				When Intelligent Key is in the antenna detection area	 <p style="text-align: right; font-size: small;">JMKIA3839GB</p>
85 (Y/L)	Ground	Room antenna (-) (Instrument center)	Output	Ignition switch ON	<p>When Intelligent Key is not in the antenna detection area</p>  <p style="text-align: right; font-size: small;">JMKIA5951GB</p>
				When Intelligent Key is in the antenna detection area	 <p style="text-align: right; font-size: small;">JMKIA3839GB</p>



# BCM (BODY CONTROL MODULE)

## < ECU DIAGNOSIS INFORMATION >

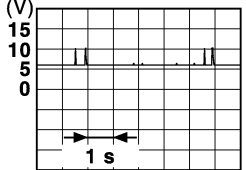
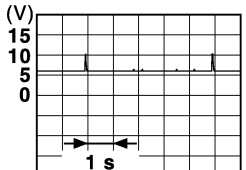
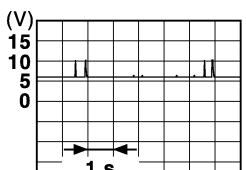
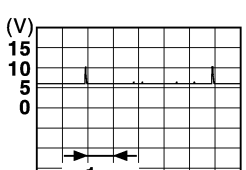
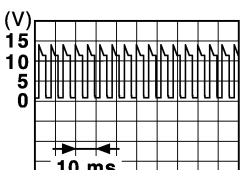
Terminal No. (Wire color)		Description		Condition	Value (Approx.)
+	-	Signal name	Input/ Output		
86 (P)	Ground	Luggage room antenna (+)	Output	Ignition switch ON	When Intelligent Key is not in the antenna detection area  <small>JMKIA5951GB</small>
				Ignition switch ON	When Intelligent Key is in the antenna detection area  <small>JMKIA3839GB</small>
87 (L)	Ground	Luggage room antenna (-)	Output	Ignition switch ON	When Intelligent Key is not in the antenna detection area  <small>JMKIA5951GB</small>
				Ignition switch ON	When Intelligent Key is in the antenna detection area  <small>JMKIA3839GB</small>
90 (W/L)	Ground	Push-button ignition switch illumination	Output	Push-button ignition switch illumination	ON 12 V OFF 0 V
91 (Y)	Ground	ACC/ON indicator lamp	Output	Ignition switch	OFF Battery voltage ACC or ON 0.5 V
				Ignition switch	OFF 0 V
92 (BR/R)	Ground	Push-button ignition switch illumination ground	Output	Tail lamp	ON  <b>NOTE:</b> When the illumination brightening/dimming level is in the neutral position  <small>JPMIA1554GB</small> 6.0 - 7.0 V

A  
B  
C  
D  
E  
F  
G  
H  
I  
J  
L  
M  
N  
O  
P

PWC

# BCM (BODY CONTROL MODULE)

## < ECU DIAGNOSIS INFORMATION >

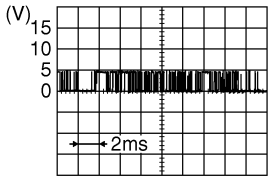
Terminal No. (Wire color)		Description		Condition		Value (Approx.)
+	-	Signal name	Input/ Output			
93 (GR/W)	Ground	Intelligent Key warn- ing buzzer	Output	Intelligent Key warning buzzer	Sounding	0 V
					Not sounding	12 V
96 (BR/W)	Ground	ACC relay control	Output	Ignition switch	OFF	0 V
					ACC or ON	12 V
97 (L/R)	Ground	Starter relay control	Output	Ignition switch ON	When selector lever is in P or N position	Battery voltage
					When selector lever is not in P or N position	0 V
98 (BR)	Ground	Ignition relay (IPDM E/R) control	Output	Ignition switch	OFF or ACC	12 V
					ON	0 V
99 (W/R)	Ground	Ignition relay control	Output	Ignition switch	OFF or ACC	0 V
					ON	12 V
100 (G)	Ground	Passenger door re- quest switch	Input	Passenger door request switch	ON (Pressed)	0 V
					OFF (Not pressed)	12 V
102 (G)	Ground	Selector lever P/N position	Input	Selector lever	P or N position	Battery voltage
					Except P and N positions	0 V
103 (G/Y)	Ground	Front defroster switch	Input	Ignition switch ON	A/C mode defroster ON position	0 V
					Other than A/C mode de- froster ON position	 <p style="text-align: right; font-size: small;">JPMIA0589GB 8.0 - 9.0 V</p>
104 (Y/R)	Ground	CVT shift selector (detention switch) power supply	Output	Ignition switch ON		12 V
105 (B/O)	Ground	Stop lamp switch 2	Input	Ignition switch OFF		Battery voltage
106 (Y/B)	Ground	Blower fan motor re- lay control	Output	Ignition switch	OFF or ACC	0 V
					ON	12 V

# BCM (BODY CONTROL MODULE)

< ECU DIAGNOSIS INFORMATION >

## WITH INTELLIGENT KEY : Wiring Diagram - BCM -

INFOID:0000000110230392

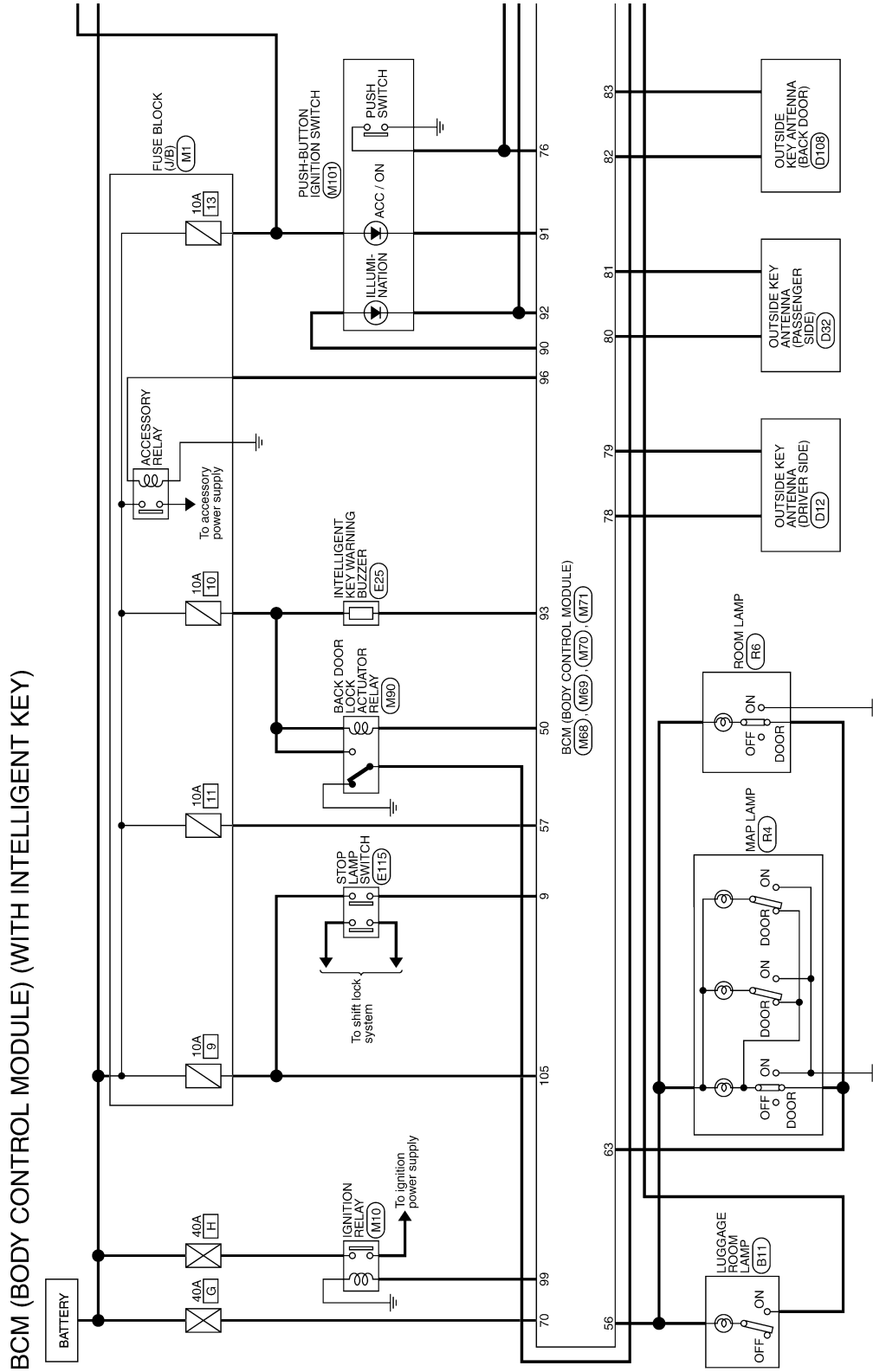

A  
B  
C  
D  
E  
F  
G  
H  
I  
J  
K  
L  
M  
N  
O  
P

PWC

2013/09/19

JRMWE7712GB

# BCM (BODY CONTROL MODULE)

< ECU DIAGNOSIS INFORMATION >

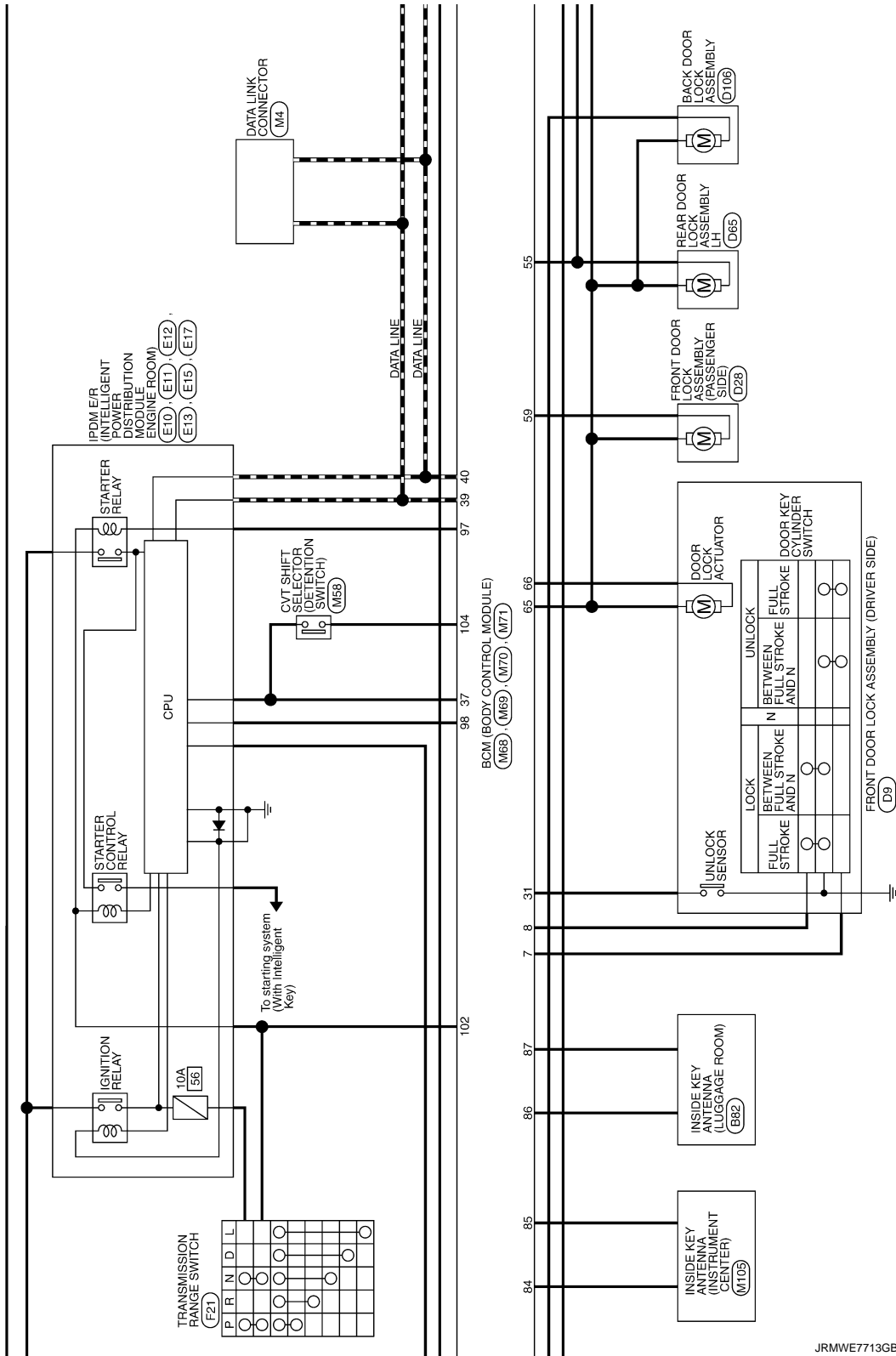

JRMWE7713GB

# BCM (BODY CONTROL MODULE)

< ECU DIAGNOSIS INFORMATION >

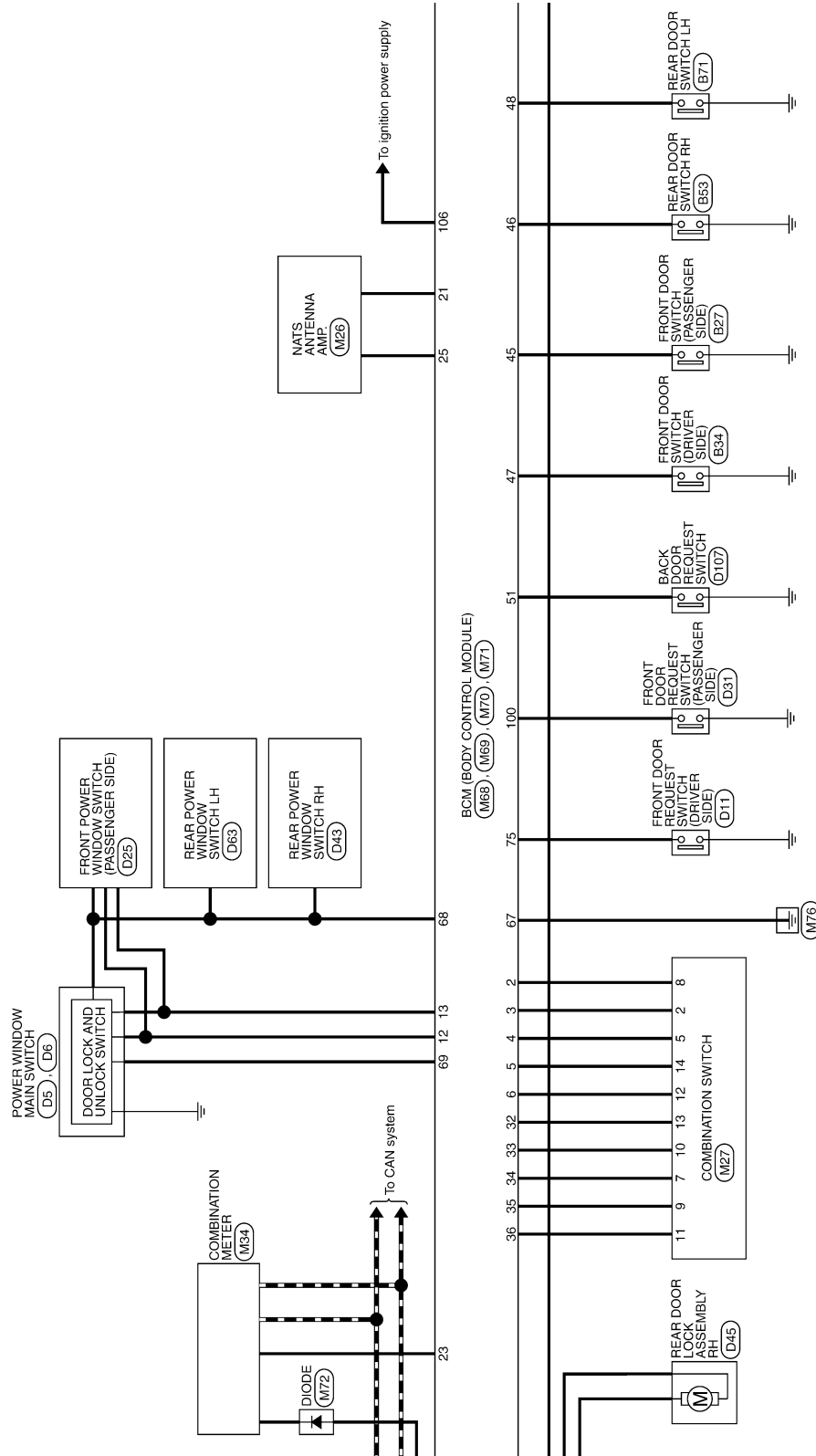

JRMWE7714GB

A  
B  
C  
D  
E  
F  
G  
H  
I  
J  
L  
M  
N  
O  
P

PWC

# BCM (BODY CONTROL MODULE)



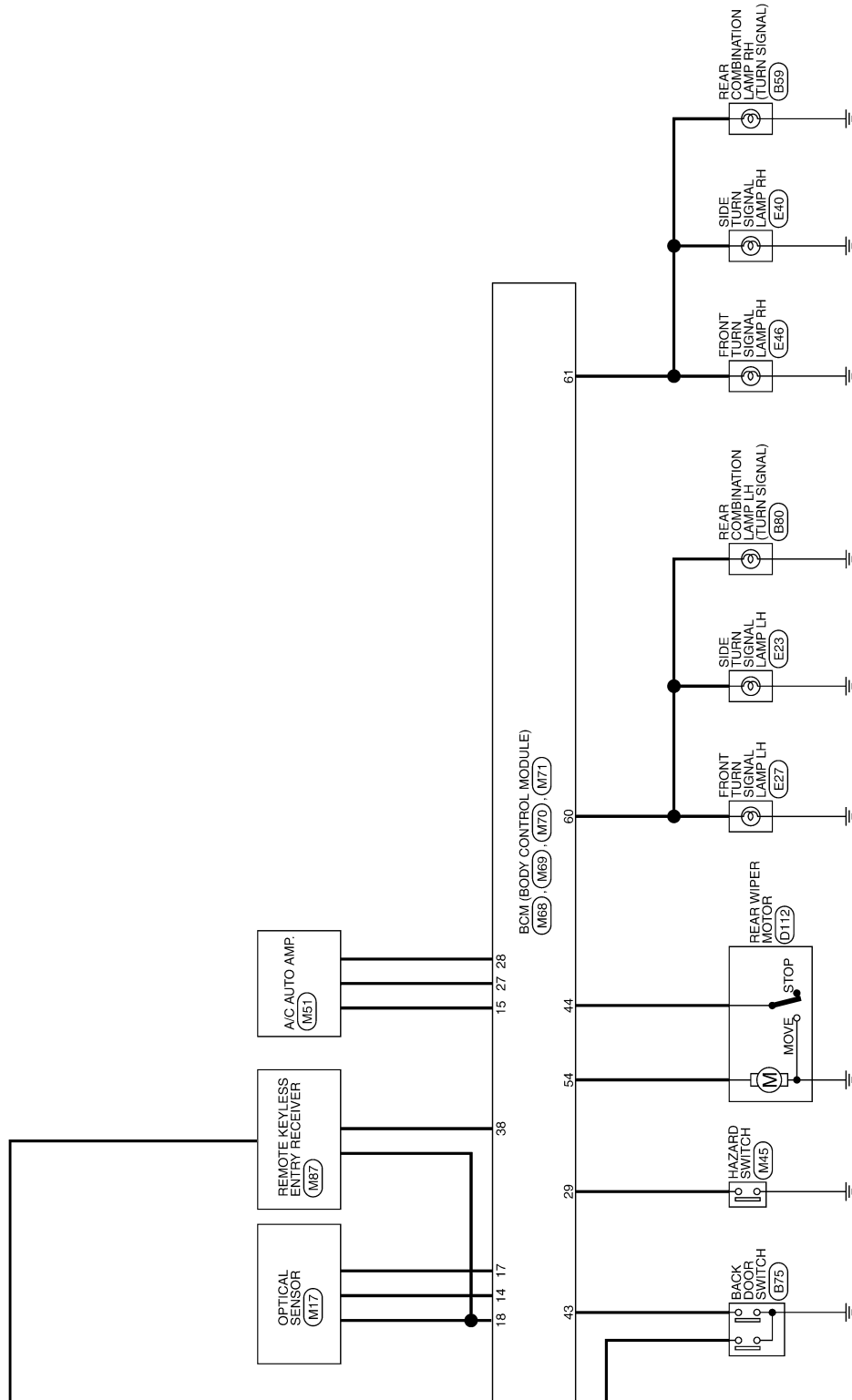





< ECU DIAGNOSIS INFORMATION >



JRMWE7715GB

# BCM (BODY CONTROL MODULE)

< ECU DIAGNOSIS INFORMATION >

BCM (BODY CONTROL MODULE) (WITH INTELLIGENT KEY)		
Connector No.	B11	
Connector Name	LUGGAGE ROOM LAMP	
Connector Type	CJ04FW	
Terminal No.	1	Y
Wire	3	L
Signal Name [Specification]		
Connector No.	B27	
Connector Name	FRONT DOOR SWITCH (PASSENGER SIDE)	
Connector Type	TH04FW-NH	
Terminal No.	1	Y
Wire	3	L
Signal Name [Specification]		
Connector No.	B53	
Connector Name	REAR DOOR SWITCH RH	
Connector Type	TH04FW-NH	
Terminal No.	3	LG
Wire	3	LG
Signal Name [Specification]		
Connector No.	B59	
Connector Name	REAR COMBINATION LAMP RH	
Connector Type	RS06FB-FR	
Terminal No.	1	Y
Wire	3	LG
Signal Name [Specification]		
Connector No.	B71	
Connector Name	REAR DOOR SWITCH LH	
Connector Type	TH04FW-NH	
Terminal No.	1	Y
Wire	3	B
Signal Name [Specification]		
Connector No.	B75	
Connector Name	BACK DOOR SWITCH	
Connector Type	TH04FW-NH	
Terminal No.	2	L
Wire	3	W
Signal Name [Specification]		
Connector No.	B80	
Connector Name	REAR COMBINATION LAMP LH	
Connector Type	RS06FB-FR	
Terminal No.	1	Y
Wire	3	B
Signal Name [Specification]		
Connector No.	B82	
Connector Name	INSIDE KEY ANTENNA (LUGGAGE ROOM)	
Connector Type	IK02FL	
Terminal No.	1	R
Wire	2	G
Signal Name [Specification]		













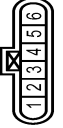

A  
B  
C  
D  
E  
F  
G  
H  
I  
J  
L  
M  
N  
O  
P

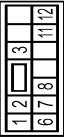

JRMWE7818GB

# BCM (BODY CONTROL MODULE)

< ECU DIAGNOSIS INFORMATION >













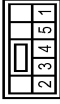

BCM (BODY CONTROL MODULE) (WITH INTELLIGENT KEY)																																																																	
<table border="1"> <tr><td>Connector No.</td><td>D5</td></tr> <tr><td>Connector Name</td><td>POWER WINDOW MAIN SWITCH</td></tr> <tr><td>Connector Type</td><td>NS16FW-CS</td></tr> </table>  	Connector No.	D5	Connector Name	POWER WINDOW MAIN SWITCH	Connector Type	NS16FW-CS	<table border="1"> <tr><td>Terminal No.</td><td>Wire</td><td>Signal Name [Specification]</td></tr> <tr><td>1</td><td>R</td><td>-</td></tr> <tr><td>2</td><td>LG</td><td>-</td></tr> <tr><td>3</td><td>O</td><td>-</td></tr> <tr><td>4</td><td>Y</td><td>-</td></tr> <tr><td>5</td><td>V</td><td>-</td></tr> <tr><td>6</td><td>LG</td><td>-</td></tr> <tr><td>7</td><td>BR</td><td>-</td></tr> <tr><td>8</td><td>V</td><td>-</td></tr> <tr><td>9</td><td>L</td><td>-</td></tr> <tr><td>10</td><td>GR</td><td>-</td></tr> <tr><td>11</td><td>SB</td><td>-</td></tr> <tr><td>12</td><td>W</td><td>-</td></tr> <tr><td>13</td><td>G</td><td>-</td></tr> <tr><td>14</td><td>W</td><td>-</td></tr> <tr><td>15</td><td>G</td><td>-</td></tr> <tr><td>16</td><td>W</td><td>-</td></tr> </table>	Terminal No.	Wire	Signal Name [Specification]	1	R	-	2	LG	-	3	O	-	4	Y	-	5	V	-	6	LG	-	7	BR	-	8	V	-	9	L	-	10	GR	-	11	SB	-	12	W	-	13	G	-	14	W	-	15	G	-	16	W	-	<table border="1"> <tr><td>Connector No.</td><td>D6</td></tr> <tr><td>Connector Name</td><td>POWER WINDOW MAIN SWITCH</td></tr> <tr><td>Connector Type</td><td>NS03FW-CS</td></tr> </table>  	Connector No.	D6	Connector Name	POWER WINDOW MAIN SWITCH	Connector Type	NS03FW-CS
Connector No.	D5																																																																
Connector Name	POWER WINDOW MAIN SWITCH																																																																
Connector Type	NS16FW-CS																																																																
Terminal No.	Wire	Signal Name [Specification]																																																															
1	R	-																																																															
2	LG	-																																																															
3	O	-																																																															
4	Y	-																																																															
5	V	-																																																															
6	LG	-																																																															
7	BR	-																																																															
8	V	-																																																															
9	L	-																																																															
10	GR	-																																																															
11	SB	-																																																															
12	W	-																																																															
13	G	-																																																															
14	W	-																																																															
15	G	-																																																															
16	W	-																																																															
Connector No.	D6																																																																
Connector Name	POWER WINDOW MAIN SWITCH																																																																
Connector Type	NS03FW-CS																																																																
<table border="1"> <tr><td>Connector No.</td><td>D9</td></tr> <tr><td>Connector Name</td><td>FRONT DOOR LOCK ASSEMBLY (DRIVER SIDE)</td></tr> <tr><td>Connector Type</td><td>ED0FFGY-RS</td></tr> </table>  	Connector No.	D9	Connector Name	FRONT DOOR LOCK ASSEMBLY (DRIVER SIDE)	Connector Type	ED0FFGY-RS	<table border="1"> <tr><td>Terminal No.</td><td>Wire</td><td>Signal Name [Specification]</td></tr> <tr><td>1</td><td>V</td><td>-</td></tr> <tr><td>2</td><td>SB</td><td>-</td></tr> <tr><td>3</td><td>G</td><td>-</td></tr> <tr><td>4</td><td>B</td><td>-</td></tr> <tr><td>5</td><td>L</td><td>-</td></tr> <tr><td>6</td><td>W</td><td>-</td></tr> </table>	Terminal No.	Wire	Signal Name [Specification]	1	V	-	2	SB	-	3	G	-	4	B	-	5	L	-	6	W	-	<table border="1"> <tr><td>Connector No.</td><td>D11</td></tr> <tr><td>Connector Name</td><td>FRONT DOOR REQUEST SWITCH (DRIVER SIDE)</td></tr> <tr><td>Connector Type</td><td>RK02FGY</td></tr> </table>  	Connector No.	D11	Connector Name	FRONT DOOR REQUEST SWITCH (DRIVER SIDE)	Connector Type	RK02FGY																														
Connector No.	D9																																																																
Connector Name	FRONT DOOR LOCK ASSEMBLY (DRIVER SIDE)																																																																
Connector Type	ED0FFGY-RS																																																																
Terminal No.	Wire	Signal Name [Specification]																																																															
1	V	-																																																															
2	SB	-																																																															
3	G	-																																																															
4	B	-																																																															
5	L	-																																																															
6	W	-																																																															
Connector No.	D11																																																																
Connector Name	FRONT DOOR REQUEST SWITCH (DRIVER SIDE)																																																																
Connector Type	RK02FGY																																																																
<table border="1"> <tr><td>Connector No.</td><td>D12</td></tr> <tr><td>Connector Name</td><td>OUTSIDE KEY ANTENNA (DRIVER SIDE)</td></tr> <tr><td>Connector Type</td><td>RK02MGY</td></tr> </table>  	Connector No.	D12	Connector Name	OUTSIDE KEY ANTENNA (DRIVER SIDE)	Connector Type	RK02MGY	<table border="1"> <tr><td>Terminal No.</td><td>Wire</td><td>Signal Name [Specification]</td></tr> <tr><td>1</td><td>P</td><td>-</td></tr> <tr><td>2</td><td>V</td><td>-</td></tr> </table>	Terminal No.	Wire	Signal Name [Specification]	1	P	-	2	V	-	<table border="1"> <tr><td>Connector No.</td><td>D25</td></tr> <tr><td>Connector Name</td><td>FRONT POWER WINDOW SWITCH (PASSENGER SIDE)</td></tr> <tr><td>Connector Type</td><td>NS12FM-CS</td></tr> </table>  	Connector No.	D25	Connector Name	FRONT POWER WINDOW SWITCH (PASSENGER SIDE)	Connector Type	NS12FM-CS																																										
Connector No.	D12																																																																
Connector Name	OUTSIDE KEY ANTENNA (DRIVER SIDE)																																																																
Connector Type	RK02MGY																																																																
Terminal No.	Wire	Signal Name [Specification]																																																															
1	P	-																																																															
2	V	-																																																															
Connector No.	D25																																																																
Connector Name	FRONT POWER WINDOW SWITCH (PASSENGER SIDE)																																																																
Connector Type	NS12FM-CS																																																																
<table border="1"> <tr><td>Connector No.</td><td>D28</td></tr> <tr><td>Connector Name</td><td>FRONT DOOR LOCK ASSEMBLY (PASSENGER SIDE)</td></tr> <tr><td>Connector Type</td><td>ED0FFGY-RS</td></tr> </table>  	Connector No.	D28	Connector Name	FRONT DOOR LOCK ASSEMBLY (PASSENGER SIDE)	Connector Type	ED0FFGY-RS	<table border="1"> <tr><td>Terminal No.</td><td>Wire</td><td>Signal Name [Specification]</td></tr> <tr><td>5</td><td>V</td><td>-</td></tr> <tr><td>6</td><td>Y</td><td>-</td></tr> </table>	Terminal No.	Wire	Signal Name [Specification]	5	V	-	6	Y	-	<table border="1"> <tr><td>Connector No.</td><td>D31</td></tr> <tr><td>Connector Name</td><td>FRONT DOOR REQUEST SWITCH (PASSENGER SIDE)</td></tr> <tr><td>Connector Type</td><td>RK02FGY</td></tr> </table>  	Connector No.	D31	Connector Name	FRONT DOOR REQUEST SWITCH (PASSENGER SIDE)	Connector Type	RK02FGY																																										
Connector No.	D28																																																																
Connector Name	FRONT DOOR LOCK ASSEMBLY (PASSENGER SIDE)																																																																
Connector Type	ED0FFGY-RS																																																																
Terminal No.	Wire	Signal Name [Specification]																																																															
5	V	-																																																															
6	Y	-																																																															
Connector No.	D31																																																																
Connector Name	FRONT DOOR REQUEST SWITCH (PASSENGER SIDE)																																																																
Connector Type	RK02FGY																																																																
<table border="1"> <tr><td>Terminal No.</td><td>Wire</td><td>Signal Name [Specification]</td></tr> <tr><td>1</td><td>GR</td><td>-</td></tr> <tr><td>2</td><td>BR</td><td>-</td></tr> <tr><td>3</td><td>B</td><td>-</td></tr> <tr><td>6</td><td>Y</td><td>-</td></tr> <tr><td>7</td><td>R</td><td>-</td></tr> <tr><td>8</td><td>L</td><td>-</td></tr> <tr><td>11</td><td>SB</td><td>-</td></tr> <tr><td>12</td><td>W</td><td>-</td></tr> </table>	Terminal No.	Wire	Signal Name [Specification]	1	GR	-	2	BR	-	3	B	-	6	Y	-	7	R	-	8	L	-	11	SB	-	12	W	-	<table border="1"> <tr><td>Terminal No.</td><td>Wire</td><td>Signal Name [Specification]</td></tr> <tr><td>1</td><td>B</td><td>-</td></tr> <tr><td>2</td><td>LG</td><td>-</td></tr> </table>	Terminal No.	Wire	Signal Name [Specification]	1	B	-	2	LG	-	<table border="1"> <tr><td>Terminal No.</td><td>Wire</td><td>Signal Name [Specification]</td></tr> <tr><td>1</td><td>GR</td><td>-</td></tr> <tr><td>2</td><td>BR</td><td>-</td></tr> <tr><td>3</td><td>B</td><td>-</td></tr> <tr><td>6</td><td>Y</td><td>-</td></tr> <tr><td>7</td><td>R</td><td>-</td></tr> <tr><td>8</td><td>L</td><td>-</td></tr> <tr><td>11</td><td>SB</td><td>-</td></tr> <tr><td>12</td><td>W</td><td>-</td></tr> </table>	Terminal No.	Wire	Signal Name [Specification]	1	GR	-	2	BR	-	3	B	-	6	Y	-	7	R	-	8	L	-	11	SB	-	12	W	-
Terminal No.	Wire	Signal Name [Specification]																																																															
1	GR	-																																																															
2	BR	-																																																															
3	B	-																																																															
6	Y	-																																																															
7	R	-																																																															
8	L	-																																																															
11	SB	-																																																															
12	W	-																																																															
Terminal No.	Wire	Signal Name [Specification]																																																															
1	B	-																																																															
2	LG	-																																																															
Terminal No.	Wire	Signal Name [Specification]																																																															
1	GR	-																																																															
2	BR	-																																																															
3	B	-																																																															
6	Y	-																																																															
7	R	-																																																															
8	L	-																																																															
11	SB	-																																																															
12	W	-																																																															
<table border="1"> <tr><td>Terminal No.</td><td>Wire</td><td>Signal Name [Specification]</td></tr> <tr><td>17</td><td>B</td><td>-</td></tr> <tr><td>18</td><td>GR</td><td>-</td></tr> <tr><td>19</td><td>P</td><td>-</td></tr> </table>	Terminal No.	Wire	Signal Name [Specification]	17	B	-	18	GR	-	19	P	-																																																					
Terminal No.	Wire	Signal Name [Specification]																																																															
17	B	-																																																															
18	GR	-																																																															
19	P	-																																																															

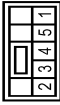
JRMWE7819GB

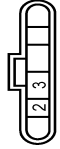

# BCM (BODY CONTROL MODULE)

< ECU DIAGNOSIS INFORMATION >



















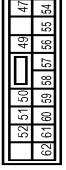



BCM (BODY CONTROL MODULE) (WITH INTELLIGENT KEY)																																																			
<table border="1"> <tr><td>Connector No.</td><td>D32</td></tr> <tr><td>Connector Name</td><td>OUTSIDE KEY ANTENNA (PASSENGER SIDE)</td></tr> <tr><td>Connector Type</td><td>RK02MGY</td></tr> </table>  	Connector No.	D32	Connector Name	OUTSIDE KEY ANTENNA (PASSENGER SIDE)	Connector Type	RK02MGY	<table border="1"> <tr><td>Terminal No.</td><td>1</td><td>2</td></tr> <tr><td>Color</td><td>P</td><td>V</td></tr> <tr><td>Wire</td><td></td><td></td></tr> <tr><td>Signal Name [Specification]</td><td></td><td></td></tr> </table>	Terminal No.	1	2	Color	P	V	Wire			Signal Name [Specification]			<table border="1"> <tr><td>Connector No.</td><td>D43</td></tr> <tr><td>Connector Name</td><td>REAR POWER WINDOW SWITCH RH</td></tr> <tr><td>Connector Type</td><td>NS08FM-CS</td></tr> </table>  	Connector No.	D43	Connector Name	REAR POWER WINDOW SWITCH RH	Connector Type	NS08FM-CS	<table border="1"> <tr><td>Terminal No.</td><td>1</td><td>2</td><td>3</td><td>4</td><td>5</td></tr> <tr><td>Color</td><td>L</td><td>BR</td><td>O</td><td>G</td><td>R</td></tr> <tr><td>Wire</td><td></td><td></td><td></td><td></td><td></td></tr> <tr><td>Signal Name [Specification]</td><td></td><td></td><td></td><td></td><td></td></tr> </table>	Terminal No.	1	2	3	4	5	Color	L	BR	O	G	R	Wire						Signal Name [Specification]					
Connector No.	D32																																																		
Connector Name	OUTSIDE KEY ANTENNA (PASSENGER SIDE)																																																		
Connector Type	RK02MGY																																																		
Terminal No.	1	2																																																	
Color	P	V																																																	
Wire																																																			
Signal Name [Specification]																																																			
Connector No.	D43																																																		
Connector Name	REAR POWER WINDOW SWITCH RH																																																		
Connector Type	NS08FM-CS																																																		
Terminal No.	1	2	3	4	5																																														
Color	L	BR	O	G	R																																														
Wire																																																			
Signal Name [Specification]																																																			
<table border="1"> <tr><td>Connector No.</td><td>D45</td></tr> <tr><td>Connector Name</td><td>REAR DOOR LOCK ASSEMBLY RH</td></tr> <tr><td>Connector Type</td><td>ED0FCY-RS</td></tr> </table>  	Connector No.	D45	Connector Name	REAR DOOR LOCK ASSEMBLY RH	Connector Type	ED0FCY-RS	<table border="1"> <tr><td>Terminal No.</td><td>5</td><td>6</td></tr> <tr><td>Color</td><td>W</td><td>P</td></tr> <tr><td>Wire</td><td></td><td></td></tr> <tr><td>Signal Name [Specification]</td><td></td><td></td></tr> </table>	Terminal No.	5	6	Color	W	P	Wire			Signal Name [Specification]			<table border="1"> <tr><td>Connector No.</td><td>D63</td></tr> <tr><td>Connector Name</td><td>REAR POWER WINDOW SWITCH LH</td></tr> <tr><td>Connector Type</td><td>NS08FM-CS</td></tr> </table>  	Connector No.	D63	Connector Name	REAR POWER WINDOW SWITCH LH	Connector Type	NS08FM-CS	<table border="1"> <tr><td>Terminal No.</td><td>1</td><td>2</td><td>3</td><td>4</td><td>5</td></tr> <tr><td>Color</td><td>L</td><td>BR</td><td>O</td><td>G</td><td>R</td></tr> <tr><td>Wire</td><td></td><td></td><td></td><td></td><td></td></tr> <tr><td>Signal Name [Specification]</td><td></td><td></td><td></td><td></td><td></td></tr> </table>	Terminal No.	1	2	3	4	5	Color	L	BR	O	G	R	Wire						Signal Name [Specification]					
Connector No.	D45																																																		
Connector Name	REAR DOOR LOCK ASSEMBLY RH																																																		
Connector Type	ED0FCY-RS																																																		
Terminal No.	5	6																																																	
Color	W	P																																																	
Wire																																																			
Signal Name [Specification]																																																			
Connector No.	D63																																																		
Connector Name	REAR POWER WINDOW SWITCH LH																																																		
Connector Type	NS08FM-CS																																																		
Terminal No.	1	2	3	4	5																																														
Color	L	BR	O	G	R																																														
Wire																																																			
Signal Name [Specification]																																																			
<table border="1"> <tr><td>Connector No.</td><td>D65</td></tr> <tr><td>Connector Name</td><td>REAR DOOR LOCK ASSEMBLY LH</td></tr> <tr><td>Connector Type</td><td>ED0FCY-RS</td></tr> </table>  	Connector No.	D65	Connector Name	REAR DOOR LOCK ASSEMBLY LH	Connector Type	ED0FCY-RS	<table border="1"> <tr><td>Terminal No.</td><td>1</td><td>2</td></tr> <tr><td>Color</td><td>V</td><td>G</td></tr> <tr><td>Wire</td><td></td><td></td></tr> <tr><td>Signal Name [Specification]</td><td></td><td></td></tr> </table>	Terminal No.	1	2	Color	V	G	Wire			Signal Name [Specification]			<table border="1"> <tr><td>Connector No.</td><td>D106</td></tr> <tr><td>Connector Name</td><td>BACK DOOR LOCK ASSEMBLY</td></tr> <tr><td>Connector Type</td><td>FEA04FB-FHA2-LC</td></tr> </table>  	Connector No.	D106	Connector Name	BACK DOOR LOCK ASSEMBLY	Connector Type	FEA04FB-FHA2-LC	<table border="1"> <tr><td>Terminal No.</td><td>2</td><td>3</td></tr> <tr><td>Color</td><td>GR</td><td>Y</td></tr> <tr><td>Wire</td><td></td><td></td></tr> <tr><td>Signal Name [Specification]</td><td></td><td></td></tr> </table>	Terminal No.	2	3	Color	GR	Y	Wire			Signal Name [Specification]														
Connector No.	D65																																																		
Connector Name	REAR DOOR LOCK ASSEMBLY LH																																																		
Connector Type	ED0FCY-RS																																																		
Terminal No.	1	2																																																	
Color	V	G																																																	
Wire																																																			
Signal Name [Specification]																																																			
Connector No.	D106																																																		
Connector Name	BACK DOOR LOCK ASSEMBLY																																																		
Connector Type	FEA04FB-FHA2-LC																																																		
Terminal No.	2	3																																																	
Color	GR	Y																																																	
Wire																																																			
Signal Name [Specification]																																																			
<table border="1"> <tr><td>Connector No.</td><td>D107</td></tr> <tr><td>Connector Name</td><td>BACK DOOR REQUEST SWITCH</td></tr> <tr><td>Connector Type</td><td>RK02FGY</td></tr> </table>  	Connector No.	D107	Connector Name	BACK DOOR REQUEST SWITCH	Connector Type	RK02FGY	<table border="1"> <tr><td>Terminal No.</td><td>1</td><td>2</td></tr> <tr><td>Color</td><td>W</td><td>B</td></tr> <tr><td>Wire</td><td></td><td></td></tr> <tr><td>Signal Name [Specification]</td><td></td><td></td></tr> </table>	Terminal No.	1	2	Color	W	B	Wire			Signal Name [Specification]			<table border="1"> <tr><td>Connector No.</td><td>D108</td></tr> <tr><td>Connector Name</td><td>OUTSIDE KEY ANTENNA (BACK DOOR)</td></tr> <tr><td>Connector Type</td><td>RK02MGY</td></tr> </table>  	Connector No.	D108	Connector Name	OUTSIDE KEY ANTENNA (BACK DOOR)	Connector Type	RK02MGY	<table border="1"> <tr><td>Terminal No.</td><td>1</td><td>2</td></tr> <tr><td>Color</td><td>BR</td><td>R</td></tr> <tr><td>Wire</td><td></td><td></td></tr> <tr><td>Signal Name [Specification]</td><td></td><td></td></tr> </table>	Terminal No.	1	2	Color	BR	R	Wire			Signal Name [Specification]														
Connector No.	D107																																																		
Connector Name	BACK DOOR REQUEST SWITCH																																																		
Connector Type	RK02FGY																																																		
Terminal No.	1	2																																																	
Color	W	B																																																	
Wire																																																			
Signal Name [Specification]																																																			
Connector No.	D108																																																		
Connector Name	OUTSIDE KEY ANTENNA (BACK DOOR)																																																		
Connector Type	RK02MGY																																																		
Terminal No.	1	2																																																	
Color	BR	R																																																	
Wire																																																			
Signal Name [Specification]																																																			

A  
B  
C  
D  
E  
F  
G  
H  
I  
J  
L  
M  
N  
O  
P

PWC

# BCM (BODY CONTROL MODULE)

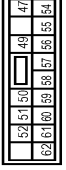













< ECU DIAGNOSIS INFORMATION >

BCM (BODY CONTROL MODULE) (WITH INTELLIGENT KEY)		BCM (BODY CONTROL MODULE) (WITH INTELLIGENT KEY)		BCM (BODY CONTROL MODULE) (WITH INTELLIGENT KEY)		BCM (BODY CONTROL MODULE) (WITH INTELLIGENT KEY)		BCM (BODY CONTROL MODULE) (WITH INTELLIGENT KEY)		BCM (BODY CONTROL MODULE) (WITH INTELLIGENT KEY)	
Connector No.	D112	Connector No.	E11	Connector No.	E13	Connector No.	E15	Connector No.	E17	Connector No.	E23
Connector Name	REAR WIPER MOTOR	Connector Name	FROM INTELLIGENT POWER DISTRIBUTION MODULE (ENGINE ROOM)	Connector Name	FROM INTELLIGENT POWER DISTRIBUTION MODULE (ENGINE ROOM)	Connector Name	FROM INTELLIGENT POWER DISTRIBUTION MODULE (ENGINE ROOM)	Connector Name	FROM INTELLIGENT POWER DISTRIBUTION MODULE (ENGINE ROOM)	Connector Name	SIDE TURN SIGNAL LAMP LH
Connector Type	CJ04FM-TV	Connector Type	M06FELC	Connector Type	TH12FM-NH	Connector Type	NS16FM-CS	Connector Type	TH10FB-NH	Connector Type	STL02FW
											
											
Terminal No.	1	Terminal No.	9	Terminal No.	24	Terminal No.	47	Terminal No.	66	Terminal No.	1
Wire	P	Wire	BAW	Wire	G	Wire	BR	Wire	W	Wire	L
Signal Name [Specification]	-	Signal Name [Specification]	L	Signal Name [Specification]	-	Signal Name [Specification]	-	Signal Name [Specification]	-	Signal Name [Specification]	-
Terminal No.	3	Terminal No.	10	Terminal No.	25	Terminal No.	49	Terminal No.	64	Terminal No.	2
Wire	BR	Wire	L	Wire	Y	Wire	W	Wire	R	Wire	L
Signal Name [Specification]	-	Signal Name [Specification]	-	Signal Name [Specification]	-	Signal Name [Specification]	-	Signal Name [Specification]	-	Signal Name [Specification]	-
Terminal No.	4	Terminal No.	13	Terminal No.	26	Terminal No.	50	Terminal No.	68	Terminal No.	2
Wire	LG	Wire	W	Wire	P	Wire	GR	Wire	L	Wire	BR
Signal Name [Specification]	-	Signal Name [Specification]	-	Signal Name [Specification]	-	Signal Name [Specification]	-	Signal Name [Specification]	-	Signal Name [Specification]	-
Connector No.	E10	Connector No.	E12	Connector No.	E16	Connector No.	E18	Connector No.	E20	Connector No.	E24
Connector Name	FROM INTELLIGENT POWER DISTRIBUTION MODULE (ENGINE ROOM)	Connector Name	FROM INTELLIGENT POWER DISTRIBUTION MODULE (ENGINE ROOM)	Connector Name	FROM INTELLIGENT POWER DISTRIBUTION MODULE (ENGINE ROOM)	Connector Name	FROM INTELLIGENT POWER DISTRIBUTION MODULE (ENGINE ROOM)	Connector Name	FROM INTELLIGENT POWER DISTRIBUTION MODULE (ENGINE ROOM)	Connector Name	FROM INTELLIGENT POWER DISTRIBUTION MODULE (ENGINE ROOM)
Connector Type	M06FW-LC	Connector Type	NS08FBCS	Connector Type	NS08FBCS	Connector Type	NS16FM-CS	Connector Type	NS16FM-CS	Connector Type	NS16FM-CS
											
											
Terminal No.	3	Terminal No.	18	Terminal No.	52	Terminal No.	62	Terminal No.	62	Terminal No.	62
Wire	BR	Wire	Y	Wire	Y	Wire	BR	Wire	BR	Wire	BR
Signal Name [Specification]	-	Signal Name [Specification]	-	Signal Name [Specification]	-	Signal Name [Specification]	-	Signal Name [Specification]	-	Signal Name [Specification]	-
Terminal No.	4	Terminal No.	19	Terminal No.	51	Terminal No.	61	Terminal No.	61	Terminal No.	61
Wire	P	Wire	BAW	Wire	R	Wire	BR	Wire	BR	Wire	BR
Signal Name [Specification]	-	Signal Name [Specification]	-	Signal Name [Specification]	-	Signal Name [Specification]	-	Signal Name [Specification]	-	Signal Name [Specification]	-
Terminal No.	5	Terminal No.	21	Terminal No.	54	Terminal No.	63	Terminal No.	63	Terminal No.	63
Wire	LG	Wire	W	Wire	GR	Wire	BR	Wire	BR	Wire	BR
Signal Name [Specification]	-	Signal Name [Specification]	-	Signal Name [Specification]	-	Signal Name [Specification]	-	Signal Name [Specification]	-	Signal Name [Specification]	-
Terminal No.	6	Terminal No.	22	Terminal No.	55	Terminal No.	64	Terminal No.	64	Terminal No.	64
Wire	SB	Wire	V	Wire	P	Wire	BR	Wire	BR	Wire	BR
Signal Name [Specification]	-	Signal Name [Specification]	-	Signal Name [Specification]	-	Signal Name [Specification]	-	Signal Name [Specification]	-	Signal Name [Specification]	-
Terminal No.	7	Terminal No.	22	Terminal No.	56	Terminal No.	65	Terminal No.	65	Terminal No.	65
Wire	Y	Wire	V	Wire	SB	Wire	BR	Wire	BR	Wire	BR
Signal Name [Specification]	-	Signal Name [Specification]	-	Signal Name [Specification]	-	Signal Name [Specification]	-	Signal Name [Specification]	-	Signal Name [Specification]	-
Terminal No.	8	Terminal No.	22	Terminal No.	57	Terminal No.	66	Terminal No.	66	Terminal No.	66
Wire	V	Wire	V	Wire	G	Wire	BR	Wire	BR	Wire	BR
Signal Name [Specification]	-	Signal Name [Specification]	-	Signal Name [Specification]	-	Signal Name [Specification]	-	Signal Name [Specification]	-	Signal Name [Specification]	-
Terminal No.		Terminal No.	38	Terminal No.	58	Terminal No.	67	Terminal No.	67	Terminal No.	67
Wire		Wire	LG	Wire	G	Wire	BR	Wire	BR	Wire	BR
Signal Name [Specification]		Signal Name [Specification]	- [With M/T]	Signal Name [Specification]	-	Signal Name [Specification]	-	Signal Name [Specification]	-	Signal Name [Specification]	-
			- [With CVT]								

JRMWE7821GB

# BCM (BODY CONTROL MODULE)

< ECU DIAGNOSIS INFORMATION >

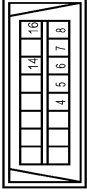
BCM (BODY CONTROL MODULE) (WITH INTELLIGENT KEY)																																																																																																										
<table border="1"> <tr><td>Connector No.</td><td>E25</td></tr> <tr><td>Connector Name</td><td>INTELLIGENT KEY WARNING BUZZER</td></tr> <tr><td>Connector Type</td><td>RK03FBR</td></tr> </table>  	Connector No.	E25	Connector Name	INTELLIGENT KEY WARNING BUZZER	Connector Type	RK03FBR	<table border="1"> <tr><td>Terminal No.</td><td>1</td><td>2</td><td>3</td></tr> <tr><td>Color</td><td>V</td><td>W</td><td>P</td></tr> <tr><td>Wire</td><td>-</td><td>-</td><td>-</td></tr> <tr><td>Signal Name [Specification]</td><td>-</td><td>-</td><td>-</td></tr> </table>	Terminal No.	1	2	3	Color	V	W	P	Wire	-	-	-	Signal Name [Specification]	-	-	-	<table border="1"> <tr><td>Connector No.</td><td>E27</td></tr> <tr><td>Connector Name</td><td>FRONT TURN SIGNAL LAMP LH</td></tr> <tr><td>Connector Type</td><td>RS02FB</td></tr> </table>  	Connector No.	E27	Connector Name	FRONT TURN SIGNAL LAMP LH	Connector Type	RS02FB																																																																												
Connector No.	E25																																																																																																									
Connector Name	INTELLIGENT KEY WARNING BUZZER																																																																																																									
Connector Type	RK03FBR																																																																																																									
Terminal No.	1	2	3																																																																																																							
Color	V	W	P																																																																																																							
Wire	-	-	-																																																																																																							
Signal Name [Specification]	-	-	-																																																																																																							
Connector No.	E27																																																																																																									
Connector Name	FRONT TURN SIGNAL LAMP LH																																																																																																									
Connector Type	RS02FB																																																																																																									
<table border="1"> <tr><td>Connector No.</td><td>E40</td></tr> <tr><td>Connector Name</td><td>SIDE TURN SIGNAL LAMP RH</td></tr> <tr><td>Connector Type</td><td>STL02FW</td></tr> </table>  	Connector No.	E40	Connector Name	SIDE TURN SIGNAL LAMP RH	Connector Type	STL02FW	<table border="1"> <tr><td>Terminal No.</td><td>1</td><td>2</td></tr> <tr><td>Color</td><td>W</td><td>BY</td></tr> <tr><td>Wire</td><td>-</td><td>-</td></tr> <tr><td>Signal Name [Specification]</td><td>-</td><td>-</td></tr> </table>	Terminal No.	1	2	Color	W	BY	Wire	-	-	Signal Name [Specification]	-	-	<table border="1"> <tr><td>Connector No.</td><td>E46</td></tr> <tr><td>Connector Name</td><td>FRONT TURN SIGNAL LAMP RH</td></tr> <tr><td>Connector Type</td><td>RS02FB</td></tr> </table>  	Connector No.	E46	Connector Name	FRONT TURN SIGNAL LAMP RH	Connector Type	RS02FB																																																																																
Connector No.	E40																																																																																																									
Connector Name	SIDE TURN SIGNAL LAMP RH																																																																																																									
Connector Type	STL02FW																																																																																																									
Terminal No.	1	2																																																																																																								
Color	W	BY																																																																																																								
Wire	-	-																																																																																																								
Signal Name [Specification]	-	-																																																																																																								
Connector No.	E46																																																																																																									
Connector Name	FRONT TURN SIGNAL LAMP RH																																																																																																									
Connector Type	RS02FB																																																																																																									
<table border="1"> <tr><td>Connector No.</td><td>E115</td></tr> <tr><td>Connector Name</td><td>STOP LAMP SWITCH</td></tr> <tr><td>Connector Type</td><td>M04FW-LC</td></tr> </table>  	Connector No.	E115	Connector Name	STOP LAMP SWITCH	Connector Type	M04FW-LC	<table border="1"> <tr><td>Terminal No.</td><td>1</td><td>2</td><td>3</td><td>4</td></tr> <tr><td>Color</td><td>V</td><td>W</td><td>O</td><td>G</td></tr> <tr><td>Wire</td><td>-</td><td>-</td><td>-</td><td>-</td></tr> <tr><td>Signal Name [Specification]</td><td>-</td><td>-</td><td>-</td><td>-</td></tr> </table>	Terminal No.	1	2	3	4	Color	V	W	O	G	Wire	-	-	-	-	Signal Name [Specification]	-	-	-	-	<table border="1"> <tr><td>Connector No.</td><td>E21</td></tr> <tr><td>Connector Name</td><td>TRANSMISSION RANGE SWITCH</td></tr> <tr><td>Connector Type</td><td>RK08FG</td></tr> </table>  	Connector No.	E21	Connector Name	TRANSMISSION RANGE SWITCH	Connector Type	RK08FG																																																																								
Connector No.	E115																																																																																																									
Connector Name	STOP LAMP SWITCH																																																																																																									
Connector Type	M04FW-LC																																																																																																									
Terminal No.	1	2	3	4																																																																																																						
Color	V	W	O	G																																																																																																						
Wire	-	-	-	-																																																																																																						
Signal Name [Specification]	-	-	-	-																																																																																																						
Connector No.	E21																																																																																																									
Connector Name	TRANSMISSION RANGE SWITCH																																																																																																									
Connector Type	RK08FG																																																																																																									
<table border="1"> <tr><td>Connector No.</td><td>M1</td></tr> <tr><td>Connector Name</td><td>FUSE BLOCK (JIB)</td></tr> <tr><td>Connector Type</td><td>24311-ED000</td></tr> </table>  	Connector No.	M1	Connector Name	FUSE BLOCK (JIB)	Connector Type	24311-ED000	<table border="1"> <tr><td>Terminal No.</td><td>1</td></tr> <tr><td>Color</td><td>W</td></tr> <tr><td>Wire</td><td>-</td></tr> <tr><td>Signal Name [Specification]</td><td>-</td></tr> </table>	Terminal No.	1	Color	W	Wire	-	Signal Name [Specification]	-	<table border="1"> <tr><td>Connector No.</td><td>M4</td></tr> <tr><td>Connector Name</td><td>DATA LINK CONNECTOR</td></tr> <tr><td>Connector Type</td><td>BDT6FW</td></tr> </table>  	Connector No.	M4	Connector Name	DATA LINK CONNECTOR	Connector Type	BDT6FW																																																																																				
Connector No.	M1																																																																																																									
Connector Name	FUSE BLOCK (JIB)																																																																																																									
Connector Type	24311-ED000																																																																																																									
Terminal No.	1																																																																																																									
Color	W																																																																																																									
Wire	-																																																																																																									
Signal Name [Specification]	-																																																																																																									
Connector No.	M4																																																																																																									
Connector Name	DATA LINK CONNECTOR																																																																																																									
Connector Type	BDT6FW																																																																																																									
<table border="1"> <tr><td>Terminal No.</td><td>1</td><td>2</td><td>3</td><td>4</td><td>5</td><td>6</td><td>7</td><td>8</td></tr> <tr><td>Color</td><td>B</td><td>B</td><td>L</td><td>O</td><td>P</td><td>LG/R</td><td>-</td><td>-</td></tr> <tr><td>Wire</td><td>-</td><td>-</td><td>-</td><td>-</td><td>-</td><td>-</td><td>-</td><td>-</td></tr> <tr><td>Signal Name [Specification]</td><td>-</td><td>-</td><td>-</td><td>-</td><td>-</td><td>-</td><td>-</td><td>-</td></tr> </table>	Terminal No.	1	2	3	4	5	6	7	8	Color	B	B	L	O	P	LG/R	-	-	Wire	-	-	-	-	-	-	-	-	Signal Name [Specification]	-	-	-	-	-	-	-	-	<table border="1"> <tr><td>Terminal No.</td><td>1</td><td>2</td><td>3</td><td>4</td><td>5</td><td>6</td><td>7</td><td>8</td></tr> <tr><td>Color</td><td>R</td><td>W</td><td>R</td><td>GR</td><td>SB</td><td>W</td><td>Y</td><td>G</td></tr> <tr><td>Wire</td><td>-</td><td>-</td><td>-</td><td>-</td><td>-</td><td>-</td><td>-</td><td>-</td></tr> <tr><td>Signal Name [Specification]</td><td>-</td><td>-</td><td>-</td><td>-</td><td>-</td><td>-</td><td>-</td><td>-</td></tr> </table>	Terminal No.	1	2	3	4	5	6	7	8	Color	R	W	R	GR	SB	W	Y	G	Wire	-	-	-	-	-	-	-	-	Signal Name [Specification]	-	-	-	-	-	-	-	-	<table border="1"> <tr><td>Terminal No.</td><td>4</td><td>5</td><td>6</td><td>7</td><td>8</td><td>14</td><td>16</td></tr> <tr><td>Color</td><td>B</td><td>B</td><td>L</td><td>GR/R</td><td>O</td><td>P</td><td>LG/R</td></tr> <tr><td>Wire</td><td>-</td><td>-</td><td>-</td><td>-</td><td>-</td><td>-</td><td>-</td></tr> <tr><td>Signal Name [Specification]</td><td>-</td><td>-</td><td>-</td><td>-</td><td>-</td><td>-</td><td>-</td></tr> </table>	Terminal No.	4	5	6	7	8	14	16	Color	B	B	L	GR/R	O	P	LG/R	Wire	-	-	-	-	-	-	-	Signal Name [Specification]	-	-	-	-	-	-	-
Terminal No.	1	2	3	4	5	6	7	8																																																																																																		
Color	B	B	L	O	P	LG/R	-	-																																																																																																		
Wire	-	-	-	-	-	-	-	-																																																																																																		
Signal Name [Specification]	-	-	-	-	-	-	-	-																																																																																																		
Terminal No.	1	2	3	4	5	6	7	8																																																																																																		
Color	R	W	R	GR	SB	W	Y	G																																																																																																		
Wire	-	-	-	-	-	-	-	-																																																																																																		
Signal Name [Specification]	-	-	-	-	-	-	-	-																																																																																																		
Terminal No.	4	5	6	7	8	14	16																																																																																																			
Color	B	B	L	GR/R	O	P	LG/R																																																																																																			
Wire	-	-	-	-	-	-	-																																																																																																			
Signal Name [Specification]	-	-	-	-	-	-	-																																																																																																			

A  
B  
C  
D  
E  
F  
G  
H  
I  
J  
L  
M  
N  
O  
P

PWC

JRMWE7822GB

# BCM (BODY CONTROL MODULE)

< ECU DIAGNOSIS INFORMATION >

**BCM (BODY CONTROL MODULE) (WITH INTELLIGENT KEY)**

Connector No. M10  
 Connector Name IGNITION RELAY  
 Connector Type MS02FL-M2-LC

Terminal No.	Color Of Wire	Signal Name [Specification]
1	B	-
2	W/B	-
3	W/B	-
5	L	-

Connector No. M17  
 Connector Name OPTICAL SENSOR  
 Connector Type TK03FW

Terminal No.	Color Of Wire	Signal Name [Specification]
1	B	-
2	W/B	-
3	L	-

Connector No. M110  
 Connector Name HAZARD SWITCH  
 Connector Type TK04FV

Terminal No.	Color Of Wire	Signal Name [Specification]
1	B	-
2	L/W	-
3	W	-
4	B/R	-

Connector No. M126  
 Connector Name NATS ANTENNA AMP.  
 Connector Type TH04FW-NH

Terminal No.	Color Of Wire	Signal Name [Specification]
1	Y	BAT
2	P/L	CLK
3	B	GND (Without Intelligent Key)
4	L/G	DATA (With Intelligent Key)
4	B	GND (With Intelligent Key)
4	L/G	DATA (Without Intelligent Key)

Connector No. M134  
 Connector Name COMBINATION METER  
 Connector Type TH06FW-NH

Terminal No.	Color Of Wire	Signal Name [Specification]
1	L	CANH
2	P	CANH
3	V	VEHICLE SPEED SIGNAL (2-PULSE)
4	L	VEHICLE SPEED SIGNAL (4-PULSE)
4	V/R	VEHICLE SPEED SIGNAL (8 PULSE (With NAVI))
6	B/R/Y	FUEL LEVEL SENSOR SIGNAL
7	R/G	AIR BAG SIGNAL
8	P	OVERDRIVE CONTROL SWITCH SIGNAL
9	O	SEAT BELT Buckle Switch Signal (Driver Side)
10	S/B	PARKING BRAKE SWITCH SIGNAL
11	G/R	BRAKE FLUID LEVEL SWITCH SIGNAL
13	B/R	ILLUMINATION CONTROL SIGNAL
15	L/Y	ACC POWER SUPPLY
18	R/Y	SECURITY SIGNAL
19	P/W	AMBIENT SENSOR SIGNAL
20	R/W	AMBIENT SENSOR GROUND
21	B	GROUND
22	B	GROUND
23	B	GROUND
24	P/U	FUEL LEVEL SENSOR GROUND
25	B	VDC GROUND
27	L/G/R	BATTERY POWER SUPPLY
28	GR	IGNITION SIGNAL
29	BR	PASSENGER SEAT BELT WARNING SIGNAL
31	R	A/C AUTO AMP. CONNECTION RECOGNITION SIGNAL
35	BR	ENGINE COOLANT TEMPERATURE SIGNAL
38	GR	ALTERNATOR SIGNAL

Connector No. M145  
 Connector Name HAZARD SWITCH  
 Connector Type TK04FV

Terminal No.	Color Of Wire	Signal Name [Specification]
1	B	-
2	L/W	-
3	W	-
4	B/R	-

Connector No. M151  
 Connector Name A/C AUTO AMP.  
 Connector Type TK16FSY

Terminal No.	Color Of Wire	Signal Name [Specification]
21	BR	WATER TEMPERATURE SIGNAL
22	P/W	AMBIENT SENSOR SIGNAL
23	O	INTAKE SENSOR SIGNAL
24	G	IN-VEHICLE SENSOR SIGNAL
25	P	SUNLOAD SENSOR SIGNAL
26	S/B	INTAKE DOOR MOTOR PBR F/B SIGNAL
27	R	REAR WINDOW DEFROGGER F/B SIGNAL
29	GR	MODE DRIVE SIGNAL 4
30	W	MODE DRIVE SIGNAL 3
31	Y	MODE DRIVE SIGNAL 2
32	V	MODE DRIVE SIGNAL 1
33	W/L	REAR WINDOW DEFROGGER ON SIGNAL
34	Y/G	A/C COIL SIGNAL
35	G/W	BLOWER FAN ON SIGNAL
36	G/R	POWER TRANSISTOR CONTROL SIGNAL

Connector No. M157  
 Connector Name COMBINATION SWITCH  
 Connector Type TH06FW-NH

Terminal No.	Color Of Wire	Signal Name [Specification]
1	O/B	WASHER (RR)
2	GR	OUTPUT 4
3	R/G	WASHER (FR)
4	W	IGN
5	L/Y	OUTPUT 3
6	B	GROUND
7	W	INPUT 3
8	B/W	OUTPUT 5
9	R/L	INPUT 5
10	Y/L	INPUT 2
11	L/O	INPUT 1
12	L/R	OUTPUT 1
13	L/G	INPUT 5
14	G	OUTPUT 2

JRMWE7823GB

# BCM (BODY CONTROL MODULE)

< ECU DIAGNOSIS INFORMATION >

BCM (BODY CONTROL MODULE) (WITH INTELLIGENT KEY)		M70	
Connector No.	Signal Name (Specification)	Terminal No.	Wire
17	OPTICAL SENSOR POWER SUPPLY	56	L
18	SENSOR GND	57	Y
21	NATS ANTENNA AMP.	58	G
23	SECURITY INDICATOR LAMP	59	G
25	NATS ANTENNA AMP.	60	W/B
27	A/C SW	61	W/L
28	BLOWER FAN SW	63	BR
29	HAZARD SW	65	V
31	DR DOOR UNLOCK SENSOR	66	L/B
32	COMBI SW OUTPUT 5	67	B
33	COMBI SW OUTPUT 4	68	L
34	COMBI SW OUTPUT 3	69	P
35	COMBI SW OUTPUT 2	70	Y
36	COMBI SW OUTPUT 1		
37	SHIF P		
38	RECEIVER COMM		
39	CANH		
40	CANL		

M71		M72	
Connector No.	Signal Name (Specification)	Terminal No.	Wire
56	INTERIOR ROOM LAMP POWER SUPPLY	83	B/W
57	BAT (FUSE)	84	Y/G
58	PASSENGER DOOR UNLOCK OUTPUT	85	Y/L
59	TURN SIGNAL LH OUTPUT	86	P
60	TURN SIGNAL RH OUTPUT	87	L
61	ROOM LAMP TIMER CONTROL	88	W/L
63	ALL DOOR LOCK OUTPUT	89	L/R
65	GROUND	90	W
66	POWER WINDOW POWER SUPPLY (IGN)	92	BR/V
68	BAT (F/L)	93	GR/W
69	BAT (R/L)	96	BR/W
70	BAT (F/L)	97	L/R

M69		M71	
Connector No.	Signal Name (Specification)	Terminal No.	Wire
43	REAR WIPER STOP POSITION	72	SB
44	PASSENGER DOOR SW	75	SB
45	REAR RH DOOR SW	76	L/O
46	DRIVER DOOR SW	78	LG
47	REAR LH DOOR SW	79	V
48	BK DR LOCK ACT RELAY CONT	80	BR/V
50	REAR WIPER OUTPUT	81	L/Y
51	REAR DOOR UNLOCK OUTPUT	82	W/B

M68		M71	
Connector No.	Signal Name (Specification)	Terminal No.	Wire
2	COMBI SW INPUT 5	1	BR
3	COMBI SW INPUT 4	2	BR/V
4	COMBI SW INPUT 3		
5	COMBI SW INPUT 2		
6	COMBI SW INPUT 1		
7	KEY CYL UNLOCK SW		
8	STOP LAMP SW/1		
9	CENTRAL DOOR LOCK SW		
12	CENTRAL DOOR UNLOCK SW		
13	OPTICAL SENSOR		
14	REAR WINDOW DEFROGGER SW		
15			

M68		M71	
Connector No.	Signal Name (Specification)	Terminal No.	Wire
1	BACK DOOR ANT-ROOM ANT+	1	BR
2	ROOM ANT-	2	BR/V
3	ROOM ANT+		
4	LUGGAGE ROOM ANT+		
5	LUGGAGE ROOM ANT-		
6	PUSH-BUTTON IGNITION SW ILL POWER		
7	ACCION IND		
8	PUSH-BUTTON IGNITION SW ILL GND		
9	L-KEY WARN BUZZER		
10	ACC RELAY CONT		
11	STARTER RELAY CONT		
12	IGN RELAY CONT		
13	IGN RELAY CONT		
14	PASSENGER DOOR REQUELST SW		
15	SHIF N/P		
16	FR DISELECTOR SW		
17	C/V T SHIF SELECTOR FOWER SUPPLY		
18	STOP LAMP SW/2		
19	BLOWER FAN MOTOR RELAY CONT		

JRMWE7824GB

A  
B  
C  
D  
E  
F  
G  
H  
I  
J  
K  
L  
M  
N  
O  
P



# BCM (BODY CONTROL MODULE)

< ECU DIAGNOSIS INFORMATION >

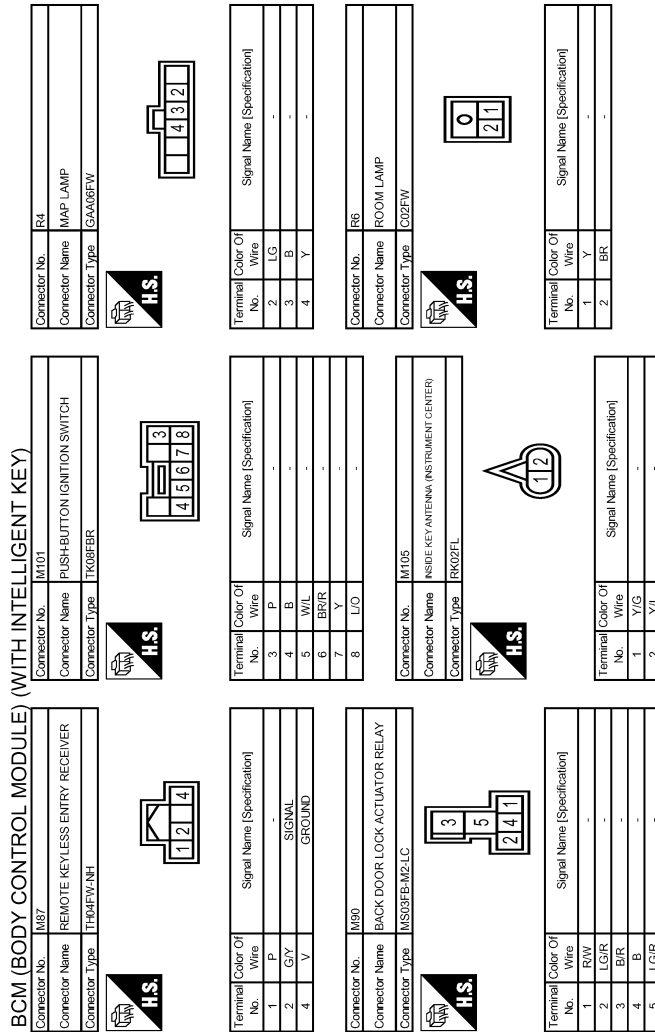

JRMWE7825GB

INFOID:0000000010230393

**WITH INTELLIGENT KEY : Fail-safe**

**FAIL-SAFE CONTROL BY DTC**

BCM performs fail-safe control when any DTC are detected.

## BCM (BODY CONTROL MODULE)

### < ECU DIAGNOSIS INFORMATION >

Display contents of CONSULT	Fail-safe	Cancellation
B2192: ID DISCORD BCM-ECM	Inhibit engine cranking	Erase DTC
B2193: CHAIN OF BCM-ECM	Inhibit engine cranking	Erase DTC
B2195: ANTI-SCANNING	Inhibit engine cranking	Ignition switch ON → OFF
B2198: NATS ANTENNA AMP	Inhibit engine cranking	Erase DTC
B2608: STARTER RELAY	Inhibit engine cranking	500 ms after the following signal communication status becomes consistent <ul style="list-style-type: none"> <li>• Starter relay control signal</li> <li>• Starter relay status signal (CAN)</li> </ul>
B260F: ENG STATE SIG LOST	Inhibit engine cranking	When any of the following conditions are fulfilled <ul style="list-style-type: none"> <li>• Power position changes to ACC</li> <li>• Receives engine status signal (CAN)</li> </ul>
B26F1: IGN RELAY OFF	Inhibit engine cranking	When the following conditions are fulfilled <ul style="list-style-type: none"> <li>• Ignition switch ON signal (CAN: Transmitted from BCM): ON</li> <li>• Ignition switch ON signal (CAN: Transmitted from IPDM E/R): ON</li> </ul>
B26F2: IGN RELAY ON	Inhibit engine cranking	When the following conditions are fulfilled <ul style="list-style-type: none"> <li>• Ignition switch ON signal (CAN: Transmitted from BCM): OFF</li> <li>• Ignition switch ON signal (CAN: Transmitted from IPDM E/R): OFF</li> </ul>
B26F3: START CONT RLY ON	Inhibit engine cranking	When the following conditions are fulfilled <ul style="list-style-type: none"> <li>• Starter control relay signal (CAN: Transmitted from BCM): OFF</li> <li>• Starter control relay signal (CAN: Transmitted from IPDM E/R): OFF</li> </ul>
B26F4: START CONT RLY OFF	Inhibit engine cranking	When the following conditions are fulfilled <ul style="list-style-type: none"> <li>• Starter control relay signal (CAN: Transmitted from BCM): ON</li> <li>• Starter control relay signal (CAN: Transmitted from IPDM E/R): ON</li> </ul>
B26F7: BCM	Inhibit engine cranking by Intelligent Key system	When room antenna and luggage room antenna functions normally

### REAR WIPER MOTOR PROTECTION

BCM detects the rear wiper stopping position according to the rear wiper stop position signal. When the rear wiper stop position signal does not change for more than 5 seconds while driving the rear wiper, BCM stops power supply to protect the rear wiper motor.

Condition of cancellation

1. More than 1 minute is passed after the rear wiper stop.
2. Turn rear wiper switch OFF.
3. Operate the rear wiper switch or rear washer switch.

### FAIL-SAFE CONTROL OF COMBINATION SWITCH READING FUNCTION CAUSED BY LOW POWER SUPPLY VOLTAGE

If voltage of battery power supply lower, BCM maintains combination switch reading to the status when input voltage is less than approximately 9 V.

#### **NOTE:**

When voltage of battery power supply is approximately 9 V or more, combination switch reading function returns to normal operation.

### WITH INTELLIGENT KEY : DTC Inspection Priority Chart

INFOID:0000000010230394

If some DTCs are displayed at the same time, perform inspections one by one based on the following priority chart.

Priority	DTC
1	B2562: LOW VOLTAGE
2	<ul style="list-style-type: none"> <li>• U1000: CAN COMM CIRCUIT</li> <li>• U1010: CONTROL UNIT (CAN)</li> </ul>

# BCM (BODY CONTROL MODULE)

## < ECU DIAGNOSIS INFORMATION >

Priority	DTC
3	<ul style="list-style-type: none"> <li>• B2192: ID DISCORD BCM-ECM</li> <li>• B2193: CHAIN OF BCM-ECM</li> <li>• B2195: ANTI-SCANNING</li> <li>• B2198: NATS ANTENNA AMP</li> </ul>
4	<ul style="list-style-type: none"> <li>• B2555: STOP LAMP</li> <li>• B2556: PUSH-BTN IGN SW</li> <li>• B2557: VEHICLE SPEED</li> <li>• B2601: SHIFT POSITION</li> <li>• B2602: SHIFT POSITION</li> <li>• B2603: SHIFT POSI STATUS</li> <li>• B2604: PNP/CLUTCH SW</li> <li>• B2605: PNP/CLUTCH SW</li> <li>• B2608: STARTER RELAY</li> <li>• B260F: ENG STATE SIG LOST</li> <li>• B2614: BCM</li> <li>• B2615: BCM</li> <li>• B2616: BCM</li> <li>• B2618: BCM</li> <li>• B261A: PUSH-BTN IGN SW</li> <li>• B26F1: IGN RELAY OFF</li> <li>• B26F2: IGN RELAY ON</li> <li>• B26F3: START CONT RLY ON</li> <li>• B26F4: START CONT RLY OFF</li> <li>• B26F6: BCM</li> <li>• B26F7: BCM</li> <li>• B26F8: BCM</li> <li>• B26FC: KEY REGISTRATION</li> <li>• C1729: VHCL SPEED SIG ERR</li> <li>• U0415: VEHICLE SPEED</li> </ul>
5	<ul style="list-style-type: none"> <li>• C1704: LOW PRESSURE FL</li> <li>• C1705: LOW PRESSURE FR</li> <li>• C1706: LOW PRESSURE RR</li> <li>• C1707: LOW PRESSURE RL</li> <li>• C1708: [NO DATA] FL</li> <li>• C1709: [NO DATA] FR</li> <li>• C1710: [NO DATA] RR</li> <li>• C1711: [NO DATA] RL</li> <li>• C1716: [PRESSDATA ERR] FL</li> <li>• C1717: [PRESSDATA ERR] FR</li> <li>• C1718: [PRESSDATA ERR] RR</li> <li>• C1719: [PRESSDATA ERR] RL</li> </ul>
6	<ul style="list-style-type: none"> <li>• B2621: INSIDE ANTENNA</li> <li>• B2622: INSIDE ANTENNA</li> </ul>
7	<ul style="list-style-type: none"> <li>• B2626: OUTSIDE ANTENNA</li> <li>• B2627: OUTSIDE ANTENNA</li> <li>• B2628: OUTSIDE ANTENNA</li> </ul>

### WITH INTELLIGENT KEY : DTC Index

INFOID:000000010230395

**NOTE:**

The details of time display are as follows.

- CRNT: A malfunction is detected now.
- PAST: A malfunction was detected in the past.

IGN counter is displayed on Freeze Frame Data. For details of Freeze Frame Data, refer to [PWC-11, "COMMON ITEM : CONSULT Function \(BCM - COMMON ITEM\)"](#).



# BCM (BODY CONTROL MODULE)

## < ECU DIAGNOSIS INFORMATION >

CONSULT display	Fail-safe	Freeze Frame Data •Vehicle Speed •Odo/Trip Meter •Vehicle Condition	Intelligent Key warning lamp ON	Tire pressure monitor warning lamp ON	Reference page
No DTC is detected. further testing may be required.	—	—	—	—	—
U1000: CAN COMM	—	—	—	—	<a href="#">BCS-40</a>
U1010: CONTROL UNIT (CAN)	—	—	—	—	<a href="#">BCS-41</a>
U0415: VEHICLE SPEED	—	—	×	—	<a href="#">BCS-42</a>
B2192: ID DISCORD BCM-ECM	×	—	—	—	<a href="#">SEC-38</a>
B2193: CHAIN OF BCM-ECM	×	—	—	—	<a href="#">SEC-40</a>
B2195: ANTI-SCANNING	×	—	—	—	<a href="#">SEC-41</a>
B2198: NATS ANTENNA AMP	×	—	—	—	<a href="#">SEC-42</a>
B2555: STOP LAMP	—	×	×	—	<a href="#">SEC-46</a>
B2556: PUSH-BTN IGN SW	—	×	×	—	<a href="#">SEC-48</a>
B2557: VEHICLE SPEED	—	×	×	—	<a href="#">SEC-50</a>
B2562: LOW VOLTAGE	—	×	—	—	<a href="#">BCS-43</a>
B2601: SHIFT POSITION	—	×	×	—	<a href="#">SEC-51</a>
B2602: SHIFT POSITION	—	×	×	—	<a href="#">SEC-54</a>
B2603: SHIFT POSI STATUS	—	×	×	—	<a href="#">SEC-57</a>
B2604: PNP/CLUTCH SW	—	×	×	—	<a href="#">SEC-62</a>
B2605: PNP/CLUTCH SW	—	×	×	—	<a href="#">SEC-65</a>
B2608: STARTER RELAY	×	×	×	—	<a href="#">SEC-67</a>
B260F: ENG STATE SIG LOST	×	×	×	—	<a href="#">SEC-69</a>
B2614: BCM	—	×	×	—	<a href="#">PCS-77</a>
B2615: BCM	—	×	×	—	<a href="#">PCS-80</a>
B2616: BCM	—	×	×	—	<a href="#">PCS-83</a>
B2618: BCM	—	×	×	—	<a href="#">PCS-86</a>
B261A: PUSH-BTN IGN SW	—	×	×	—	<a href="#">PCS-87</a>
B2621: INSIDE ANTENNA	—	×	—	—	<a href="#">DLK-44</a>
B2622: INSIDE ANTENNA	—	×	—	—	<a href="#">DLK-46</a>
B2626: OUTSIDE ANTENNA	—	×	—	—	<a href="#">DLK-50</a>
B2627: OUTSIDE ANTENNA	—	×	—	—	<a href="#">DLK-48</a>
B2628: OUTSIDE ANTENNA	—	×	—	—	<a href="#">DLK-52</a>
B26F1: IGN RELAY OFF	×	×	×	—	<a href="#">PCS-89</a>
B26F2: IGN RELAY ON	×	×	×	—	<a href="#">PCS-91</a>
B26F3: START CONT RLY ON	×	×	×	—	<a href="#">SEC-70</a>
B26F4: START CONT RLY OFF	×	×	×	—	<a href="#">SEC-71</a>
B26F6: BCM	—	×	×	—	<a href="#">PCS-93</a>
B26F7: BCM	×	×	×	—	<a href="#">SEC-73</a>
B26F8: BCM	—	×	×	—	<a href="#">SEC-74</a>
B26FC: KEY REGISTRATION	—	×	×	—	<a href="#">SEC-75</a>

A

B

C

D

E

F

G

H

I

J

PWC

L

M

N

O

P

# BCM (BODY CONTROL MODULE)

## < ECU DIAGNOSIS INFORMATION >

CONSULT display	Fail-safe	Freeze Frame Data •Vehicle Speed •Odo/Trip Meter •Vehicle Condition	Intelligent Key warning lamp ON	Tire pressure monitor warning lamp ON	Reference page
C1704: LOW PRESSURE FL	—	—	—	×	<a href="#">WT-26</a>
C1705: LOW PRESSURE FR	—	—	—	×	
C1706: LOW PRESSURE RR	—	—	—	×	
C1707: LOW PRESSURE RL	—	—	—	×	
C1708: [NO DATA] FL	—	—	—	×	<a href="#">WT-28</a>
C1709: [NO DATA] FR	—	—	—	×	
C1710: [NO DATA] RR	—	—	—	×	
C1711: [NO DATA] RL	—	—	—	×	
C1716: [PRESSDATA ERR] FL	—	—	—	×	<a href="#">WT-31</a>
C1717: [PRESSDATA ERR] FR	—	—	—	×	
C1718: [PRESSDATA ERR] RR	—	—	—	×	
C1719: [PRESSDATA ERR] RL	—	—	—	×	
C1729: VHCL SPEED SIG ERR	—	—	—	×	<a href="#">WT-33</a>

### WITHOUT INTELLIGENT KEY

### WITHOUT INTELLIGENT KEY : Reference Value

INFOID:0000000010230397

### VALUES ON THE DIAGNOSIS TOOL

#### NOTE:

The following table includes information (items) inapplicable to this vehicle. For information (items) applicable to this vehicle, refer to CONSULT display items.

Monitor Item	Condition	Value/Status
IGN ON SW	Ignition switch OFF or ACC	Off
	Ignition switch ON	On
KEY ON SW	Mechanical key is removed from key cylinder	Off
	Mechanical key is inserted to key cylinder	On
CDL LOCK SW	Door lock/unlock switch does not operate	Off
	Press door lock/unlock switch to the lock side	On
CDL UNLOCK SW	Door lock/unlock switch does not operate	Off
	Press door lock/unlock switch to the unlock side	On
DOOR SW-DR	Driver's door closed	Off
	Driver's door opened	On
DOOR SW-AS	Passenger door closed	Off
	Passenger door opened	On
DOOR SW-RR	Rear RH door closed	Off
	Rear RH door opened	On
DOOR SW-RL	Rear LH door closed	Off
	Rear LH door opened	On
BACK DOOR SW	Back door closed	Off
	Back door opened	On
LOCK STATUS	<b>NOTE:</b> The item is indicated, but not monitored.	Off

## BCM (BODY CONTROL MODULE)

### < ECU DIAGNOSIS INFORMATION >

Monitor Item	Condition	Value/Status
ACC ON SW	Ignition switch OFF	Off
	Ignition switch ACC or ON	On
KEYLESS LOCK	"LOCK" button of key fob is not pressed	Off
	"LOCK" button of key fob is pressed	On
KEYLESS UNLOCK	"UNLOCK" button of key fob is not pressed	Off
	"UNLOCK" button of key fob is pressed	On
SHOCK SENSOR	<b>NOTE:</b> The item is indicated, but not monitored.	NORMAL
KEY CYL LK-SW	Other than driver door key cylinder LOCK position	Off
	Driver door key cylinder LOCK position	On
KEY CYL UN-SW	Other than driver door key cylinder UNLOCK position	Off
	Driver door key cylinder UNLOCK position	On
VEHICLE SPEED	While driving	Equivalent to speedometer reading
REAR DEF SW	Rear window defogger switch OFF	Off
	Rear window defogger switch ON	On
REVERSE SW CAN	<b>NOTE:</b> The item is indicated, but not used.	Off
		On
TAIL LAMP SW	Lighting switch OFF	Off
	Lighting switch 1ST	On
FR FOG SW	<b>NOTE:</b> The item is indicated, but not monitored.	Off
BUCKLE SW	The seat belt (driver side) is fastened. [Seat belt switch (driver side) OFF]	Off
	The seat belt (driver side) is unfastened. [Seat belt switch (driver side) ON]	On
TRNK/HAT MNTR	<b>NOTE:</b> The item is indicated, but not monitored.	Off
KYLS TRNK/HAT	<b>NOTE:</b> The item is indicated, but not monitored.	Off
KEYLESS PANIC	PANIC button of key fob is not pressed	Off
	PANIC button of key fob is pressed	On
HI BEAM SW	Lighting switch OFF	Off
	Lighting switch HI	On
HEAD LAMP SW 1	Lighting switch OFF	Off
	Lighting switch 2ND	On
HEAD LAMP SW 2	Lighting switch OFF	Off
	Lighting switch 2ND	On
AUTO LIGHT SW	<b>NOTE:</b> The item is indicated, but not monitored.	Off
PASSING SW	Other than lighting switch PASS	Off
	Lighting switch PASS	On
RR FOG SW	<b>NOTE:</b> The item is indicated, but not monitored.	Off
TURN SIGNAL R	Turn signal switch OFF	Off
	Turn signal switch RH	On
TURN SIGNAL L	Turn signal switch OFF	Off
	Turn signal switch LH	On

A  
B  
C  
D  
E  
F  
G  
H  
I  
J  
PWC  
L  
M  
N  
O  
P

## BCM (BODY CONTROL MODULE)

### < ECU DIAGNOSIS INFORMATION >

Monitor Item	Condition	Value/Status
PKB SW	Parking brake switch is OFF	Off
	Parking brake switch is ON	On
ENGINE RUN	Engine stopped	Off
	Engine running	On
OPTI SEN (DTCT)	<b>NOTE:</b> The item is indicated, but not monitored.	Close to 5 V
OPTI SEN (FILT)	<b>NOTE:</b> The item is indicated, but not monitored.	Close to 5 V
LIG SEN COND	<b>NOTE:</b> The item is indicated, but not monitored.	OFF
IGN SW CAN	Ignition switch OFF or ACC	Off
	Ignition switch ON	On
FR WIPER HI	Front wiper switch OFF	Off
	Front wiper switch HI	On
FR WIPER LOW	Front wiper switch OFF	Off
	Front wiper switch LO	On
FR WIPER INT	Front wiper switch OFF	Off
	Front wiper switch INT	On
FR WASHER SW	Front washer switch OFF	Off
	Front washer switch ON	On
INT VOLUME	Wiper intermittent dial is in a dial position 1 - 7	1 - 7
FR WIPER STOP	Any position other than front wiper stop position	Off
	Front wiper stop position	On
RR WIPER ON	Rear wiper switch OFF	Off
	Rear wiper switch ON	On
RR WIPER INT	Rear wiper switch OFF	Off
	Rear wiper switch INT	On
RR WASHER SW	Rear washer switch OFF	Off
	Rear washer switch ON	On
RR WIPER STOP	Rear wiper stop position	Off
	Other than rear wiper stop position	On
RAIN SENSOR	<b>NOTE:</b> The item is indicated, but not monitored.	Off
HAZARD SW	Hazard switch OFF	Off
	Hazard switch ON	On
FAN ON SIG	Blower control dial OFF	Off
	Other than blower control dial OFF	On
AIR COND SW	A/C switch OFF	Off
	A/C switch ON	On
THERMO AMP	Ignition switch ON	Off
	Evaporator is extremely low temperature	On
FR DEF SW	Other than A/C mode defroster ON position	Off
	A/C mode defroster ON position	On
KEYLESS TRUNK	<b>NOTE:</b> The item is indicated, but not monitored.	Off

## BCM (BODY CONTROL MODULE)

### < ECU DIAGNOSIS INFORMATION >

Monitor Item	Condition	Value/Status	
TRNK OPNR SW	<b>NOTE:</b> The item is indicated, but not monitored.	Off	A
TRNK OPN MNTR	<b>NOTE:</b> The item is indicated, but not monitored.	Off	B
HOOD SW	Close the hood	Off	C
	Open the hood	On	
TRANSPONDER	Other than the ignition switch is ON by key registered to BCM.	Off	D
	The ignition switch is ON by key registered to BCM.	On	
INTELLI KEY	<b>NOTE:</b> The item is indicated, but not used.	Off	E
AUTO RELOCK	<b>NOTE:</b> The item is indicated, but not monitored.	Off	F
OIL PRESS SW	<ul style="list-style-type: none"> <li>• Ignition switch OFF or ACC</li> <li>• Engine running</li> </ul>	Off	F
	Ignition switch ON	On	
BRAKE SW	Brake pedal is not depressed	Off	G
	Brake pedal is depressed	On	

A  
B  
C  
D  
E  
F  
G  
H  
I  
J  
L  
M  
N  
O  
P

PWC

# BCM (BODY CONTROL MODULE)

< ECU DIAGNOSIS INFORMATION >

## TERMINAL LAYOUT

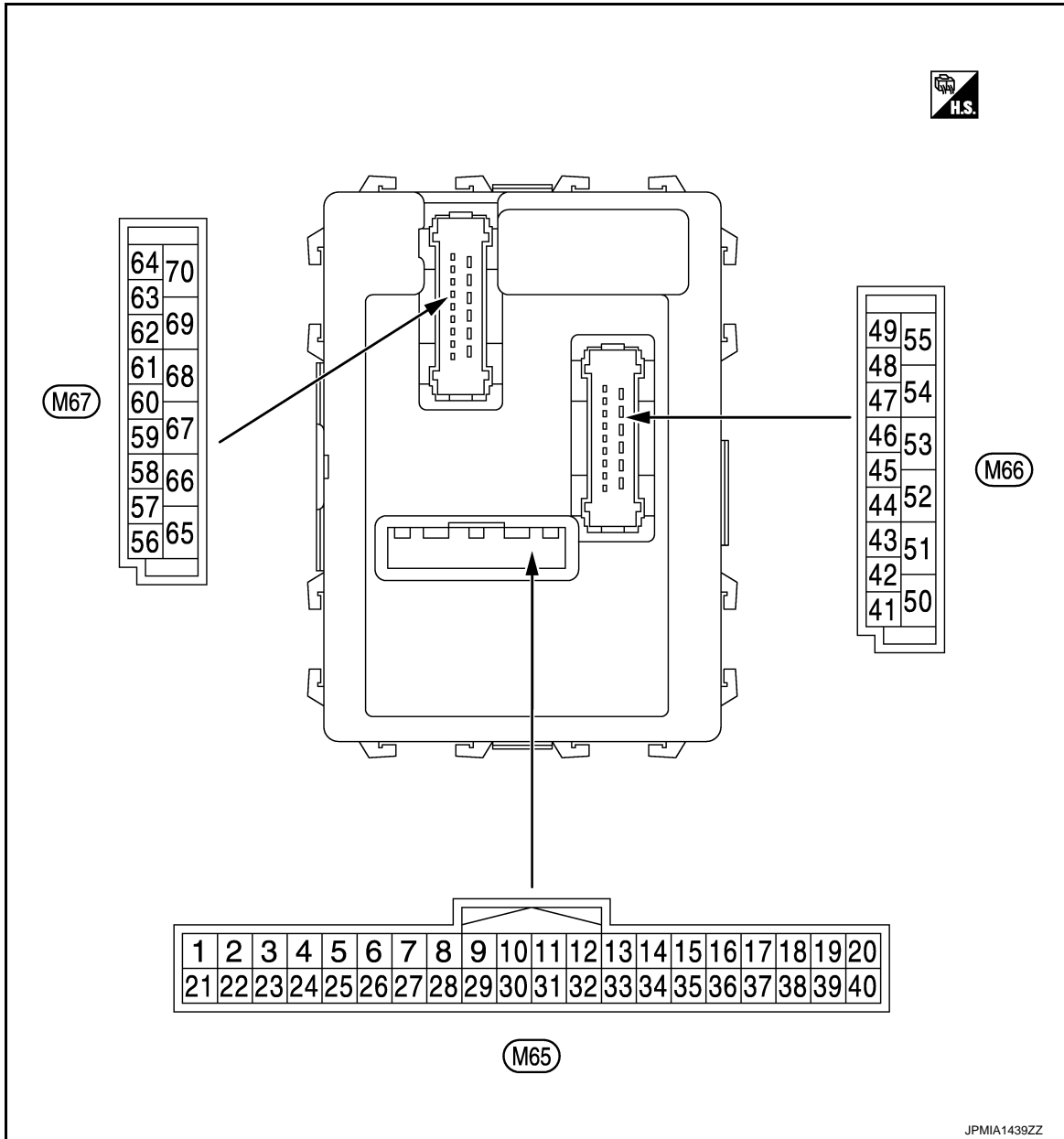

# BCM (BODY CONTROL MODULE)

< ECU DIAGNOSIS INFORMATION >

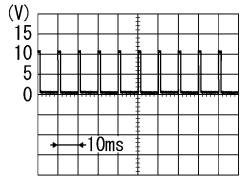
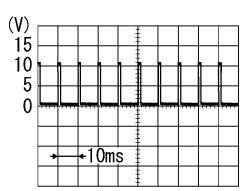
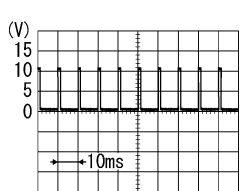
Terminal No. (Wire color)		Description		Condition	Value (Approx.)	
+	-	Signal name	Input/ Output			
2 (BR/W)	Ground	Combination switch INPUT 5	Input	Combination switch (Wiper intermit- tent dial 4)	All switch OFF	0 V
					Turn signal switch RH	
					Lighting switch HI	
					Lighting switch 1ST	
					Lighting switch 2ND	
3 (GR)	Ground	Combination switch INPUT 4	Input	Combination switch (Wiper intermit- tent dial 4)	All switch OFF	0 V
					Turn signal switch LH	
					Lighting switch PASS	
					Lighting switch 2ND	
4 (L/Y)	Ground	Combination switch INPUT 3	Input	Combination switch (Wiper intermit- tent dial 4)	All switch OFF	0 V
					Front wiper switch LO	
					Front wiper switch MIST	
					Front wiper switch INT	

A  
B  
C  
D  
E  
F  
G  
H  
I  
J  
PWC  
L  
M  
N  
O  
P

# BCM (BODY CONTROL MODULE)

## < ECU DIAGNOSIS INFORMATION >

Terminal No. (Wire color)		Description		Condition	Value (Approx.)	
+	-	Signal name	Input/ Output			
5 (G)	Ground	Combination switch INPUT 2	Input	Combination switch	All switch OFF (Wiper intermittent dial 4)	0 V
					Front washer switch (Wiper intermittent dial 4)	
					Rear washer switch ON (Wiper intermittent dial 4)	
					Any of the condition below with all switch OFF <ul style="list-style-type: none"> <li>• Wiper intermittent dial 1</li> <li>• Wiper intermittent dial 5</li> <li>• Wiper intermittent dial 6</li> </ul>	
Rear wiper switch ON (Wiper intermittent dial 4)		0.8 V				
6 (L/R)	Ground	Combination switch INPUT 1	Input	Combination switch	All switch OFF (Wiper intermittent dial 4)	0 V
					Front wiper switch HI (Wiper intermittent dial 4)	
					Rear wiper switch INT (Wiper intermittent dial 4)	
					Wiper intermittent dial 3 (All switch OFF)	
					Any of the condition below with all switch OFF <ul style="list-style-type: none"> <li>• Wiper intermittent dial 1</li> <li>• Wiper intermittent dial 2</li> </ul>	
Any of the condition below with all switch OFF <ul style="list-style-type: none"> <li>• Wiper intermittent dial 6</li> <li>• Wiper intermittent dial 7</li> </ul>		0.8 V				



# BCM (BODY CONTROL MODULE)

## < ECU DIAGNOSIS INFORMATION >

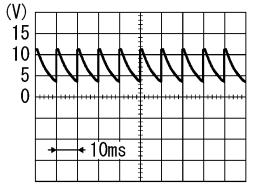
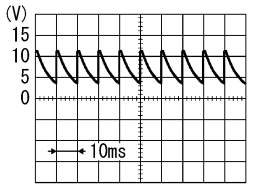
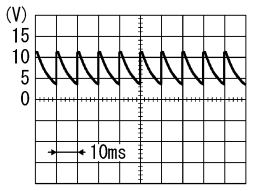
Terminal No. (Wire color)		Description		Condition	Value (Approx.)	
+	-	Signal name	Input/ Output			
7 (W/R)	Ground	Door key cylinder switch UNLOCK	Input	Door key cylinder switch	NEUTRAL position	 <p style="text-align: center;">7.0 - 8.0 V</p>
					UNLOCK position	
8 (W/B)	Ground	Door key cylinder switch LOCK	Input	Door key cylinder switch	NEUTRAL position	12 V
					LOCK position	0 V
9 (R)	Ground	Stop lamp switch	Input	Stop lamp switch	OFF (Brake pedal is not depressed)	0 V
					ON (Brake pedal is de- pressed)	Battery voltage
10 (W/L)	Ground	Rear window defog- ger switch	Input	Rear window defogger switch	OFF (Not pressed)	12 V
					ON (Pressed)	0 V
11 (L/Y)	Ground	Ignition switch ACC	Input	Ignition switch OFF		0 V
				Ignition switch ACC or ON		Battery voltage
12 (SB)	Ground	Passenger door switch	Input	Passenger door switch	OFF (When passenger door closed)	 <p style="text-align: center;">7.0 - 8.0 V</p>
					ON (When passenger door opened)	
13 (GR/L)	Ground	Rear RH door switch	Input	Rear RH door switch	OFF (When rear RH door closed)	 <p style="text-align: center;">7.0 - 8.0 V</p>
					ON (When rear RH door opened)	
18 (V)	Ground	Receiver ground	Input	Ignition switch ON		0 V

A  
B  
C  
D  
E  
F  
G  
H  
I  
J  
L  
M  
N  
O  
P

PWC

# BCM (BODY CONTROL MODULE)

## < ECU DIAGNOSIS INFORMATION >

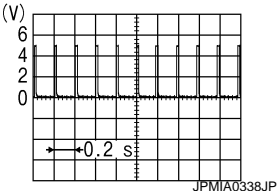
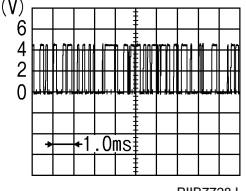
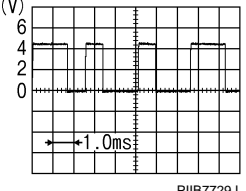
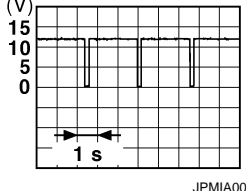
Terminal No. (Wire color)		Description		Condition	Value (Approx.)
+	-	Signal name	Input/ Output		
19 (BR)	Ground	Remote keyless entry receiver power supply	Input	Ignition switch OFF	0 V
				Remove mechanical key from ignition key cylinder (Any door opened)	5 V
				Remove mechanical key from ignition key cylinder (Any door closed)	 <p style="text-align: right; font-size: small;">JPMA0338JP</p>
20 (G/Y)	Ground	Remote keyless entry receiver communication	Input	Ignition switch OFF	0 V
				Waiting	 <p style="text-align: right; font-size: small;">PIIB7728J</p>
				Signal receiving	 <p style="text-align: right; font-size: small;">PIIB7729J</p>
21 (P/L)	Ground	NATS antenna amp.	Input/ Output	Just after inserting ignition key in key cylinder	Pointer of tester should move
				Other than above	0 V
23 (R/Y)	Ground	Security indicator	Input	Security indicator	0 V
				ON	0 V
				Blinking (Ignition switch OFF)	 <p style="text-align: right; font-size: small;">JPMA0014GB</p>
				OFF	12 V
25 (LG)	Ground	NATS antenna amp.	Input/ Output	Just after inserting ignition key in key cylinder	Pointer of tester should move
				Other than above	0 V
26 (GR)	Ground	Thermo control amp.	Input	Ignition switch ON	0 V
				Evaporator is extremely low temperature	12 V

# BCM (BODY CONTROL MODULE)

## < ECU DIAGNOSIS INFORMATION >

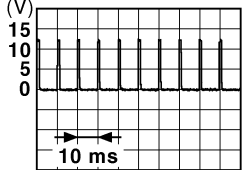
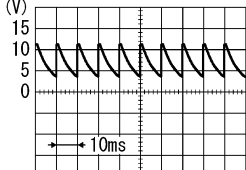
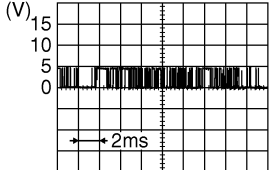
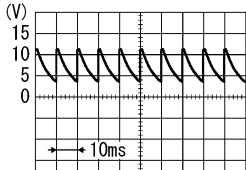
Terminal No. (Wire color)		Description		Condition	Value (Approx.)	
+	-	Signal name	Input/ Output			
27 (Y/G)	Ground	A/C switch	Input	A/C switch	 <p style="text-align: right; font-size: small;">JPMIA0012GB</p> <p style="text-align: center;">1.0 - 1.5 V</p>	
				A/C switch	OFF	0 V
28 (G/W)	Ground	Blower fan switch	Input	Fan switch	 <p style="text-align: right; font-size: small;">PKIB4960J</p> <p style="text-align: center;">7.0 - 8.0 V</p>	
				Fan switch	Blower fan switch ON	0 V
29 (L/W)	Ground	Hazard switch	Input	Hazard switch	OFF	Battery voltage
				Hazard switch	ON	0 V
31 (G/Y)	Ground	Front defroster switch	Input	Ignition switch ON	A/C mode defroster ON position	0 V
				Ignition switch ON	Other than A/C mode defroster ON position	 <p style="text-align: right; font-size: small;">JPMIA0589GB</p> <p style="text-align: center;">8.0 - 9.0 V</p>
32 (LG)	Ground	Combination switch OUTPUT 5	Output	Combination switch	All switch OFF (Wiper intermittent dial 4)	 <p style="text-align: right; font-size: small;">PKIB4960J</p> <p style="text-align: center;">7.0 - 8.0 V</p>
				Combination switch	Rear wiper switch ON (Wiper intermittent dial 4)	Any of the condition below with all switch OFF

A  
B  
C  
D  
E  
F  
G  
H  
I  
J  
L  
M  
N  
O  
P



# BCM (BODY CONTROL MODULE)

## < ECU DIAGNOSIS INFORMATION >

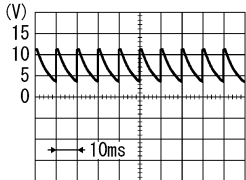
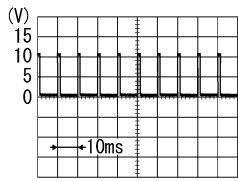
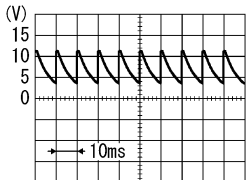
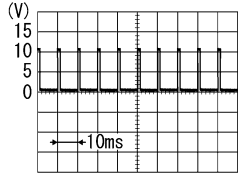
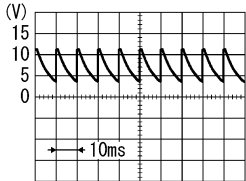
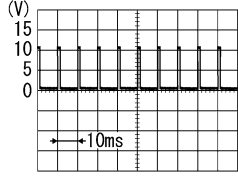
Terminal No. (Wire color)		Description		Condition	Value (Approx.)	
		Signal name	Input/ Output			
+	-					
33 (Y/L)	Ground	Combination switch OUTPUT 4	Output	Combination switch	All switch OFF (Wiper intermittent dial 4)	 <p style="text-align: right; font-size: small;">PKIB4960J</p> <p style="text-align: center;">7.0 - 8.0 V</p>
					Lighting switch 1ST (Wiper intermittent dial 4)	 <p style="text-align: right; font-size: small;">PKIB4958J</p> <p style="text-align: center;">1.2 V</p>
					Rear wiper switch INT (Wiper intermittent dial 4)	
					Any of the condition below with all switch OFF <ul style="list-style-type: none"> <li>• Wiper intermittent dial 1</li> <li>• Wiper intermittent dial 5</li> <li>• Wiper intermittent dial 6</li> </ul>	
34 (W)	Ground	Combination switch OUTPUT 3	Output	Combination switch	All switch OFF (Wiper intermittent dial 4)	 <p style="text-align: right; font-size: small;">PKIB4960J</p> <p style="text-align: center;">7.0 - 8.0 V</p>
					Lighting switch 2ND (Wiper intermittent dial 4)	 <p style="text-align: right; font-size: small;">PKIB4958J</p> <p style="text-align: center;">1.2 V</p>
					Lighting switch HI (Wiper intermittent dial 4)	
					Rear washer switch ON (Wiper intermittent dial 4)	
Any of the condition below with all switch OFF <ul style="list-style-type: none"> <li>• Wiper intermittent dial 1</li> <li>• Wiper intermittent dial 2</li> <li>• Wiper intermittent dial 3</li> </ul>						
35 (R/L)	Ground	Combination switch OUTPUT 2	Output	Combination switch (Wiper intermit- tent dial 4)	All switch OFF	 <p style="text-align: right; font-size: small;">PKIB4960J</p> <p style="text-align: center;">7.0 - 8.0 V</p>
					Lighting switch 2ND	 <p style="text-align: right; font-size: small;">PKIB4958J</p> <p style="text-align: center;">1.2 V</p>
					Lighting switch PASS	
					Front wiper switch INT	
Front wiper switch HI						

# BCM (BODY CONTROL MODULE)

## < ECU DIAGNOSIS INFORMATION >

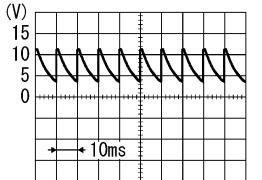
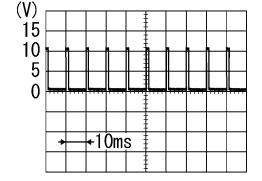
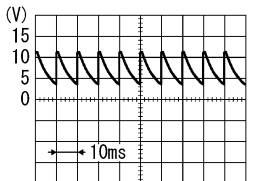
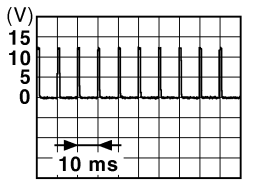
Terminal No. (Wire color)		Description		Condition	Value (Approx.)	
+	-	Signal name	Input/ Output			
36 (L/O)	Ground	Combination switch OUTPUT 1	Output	Combination switch (Wiper intermit- tent dial 4)	All switch OFF	 <p style="text-align: right; font-size: small;">PKIB4960J</p> <p style="text-align: center;">7.0 - 8.0 V</p>
					Turn signal switch RH	 <p style="text-align: right; font-size: small;">PKIB4958J</p> <p style="text-align: center;">1.2 V</p>
					Turn signal switch LH	
					Front wiper switch LO (Front wiper switch MIST)	
				Front washer switch ON		
37 (R/W)	Ground	Key switch	Input	Insert mechanical key into ignition key cylinder	Battery voltage	
				Remove mechanical key from ignition key cylinder	0 V	
38 (O)	Ground	Ignition switch ON	Input	Ignition switch OFF or ACC	0 V	
				Ignition switch ON	Battery voltage	
39 (L)	Ground	CAN-H	Input/ Output	—	—	
40 (P)	Ground	CAN-L	Input/ Output	—	—	
43 (W)	Ground	Back door switch	Input	Back door switch	OFF (When back door closed)	 <p style="text-align: right; font-size: small;">PKIB4960J</p> <p style="text-align: center;">7.0 - 8.0 V</p>
					ON (When back door opened)	0 V
44 (LG)	Ground	Rear wiper stop po- sition	Input	Ignition switch ON	Rear wiper stop position	12 V
					Any position other than rear wiper stop position	0 V
45 (GR)	Ground	Door lock and unlock switch LOCK	Input	Door lock and unlock switch	NEUTRAL position	 <p style="text-align: right; font-size: small;">JPMIA0012GB</p> <p style="text-align: center;">1.0 - 1.5 V</p>
					LOCK position	0 V

A  
B  
C  
D  
E  
F  
G  
H  
I  
J  
L  
M  
N  
O  
P

PWC

# BCM (BODY CONTROL MODULE)

## < ECU DIAGNOSIS INFORMATION >

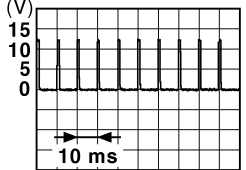
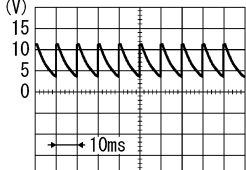
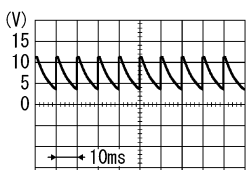
Terminal No. (Wire color)		Description		Condition		Value (Approx.)
+	-	Signal name	Input/ Output			
46 (BR)	Ground	Door lock and unlock switch UNLOCK	Input	Door lock and unlock switch	NEUTRAL position	 <small>JPMIA0012GB</small> 1.0 - 1.5 V
					UNLOCK position	0 V
47 (BR/Y)	Ground	Driver door switch	Input	Driver door switch	OFF (When driver door closed)	 <small>PKIB4960J</small> 7.0 - 8.0 V
					ON (When driver door opened)	0 V
48 (W/G)	Ground	Rear LH door switch	Input	Rear LH door switch	OFF (When rear LH door closed)	 <small>PKIB4960J</small> 7.0 - 8.0 V
					ON (When rear LH door opened)	0 V
50 (SB)	Ground	A/C indicator	Output	A/C indicator	OFF	12 V
					ON	0 V
54 (LG)	Ground	Rear wiper	Output	Ignition switch ON	Rear wiper switch OFF	0 V
					Rear wiper switch ON	12 V
56 (L)	Ground	Interior room lamp power supply	Output	Interior room lamp battery saver is activated. (Cuts the interior room lamp power supply)		0 V
				Interior room lamp battery saver is not activated. (Outputs the interior room lamp power supply)		12 V
57 (Y)	Ground	Battery power supply	Input	Ignition switch OFF		Battery voltage
59 (L/B)	Ground	Driver door UNLOCK	Output	Driver door	UNLOCK (Actuator is activated)	12 V
					Other than UNLOCK (Actuator is not activated)	0 V

# BCM (BODY CONTROL MODULE)

## < ECU DIAGNOSIS INFORMATION >

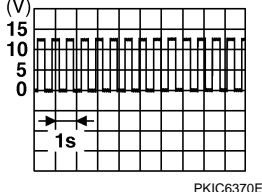
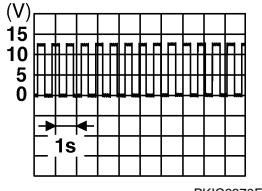
Terminal No. (Wire color)		Description		Condition	Value (Approx.)
+	-	Signal name	Input/ Output		
60 (W/B)	Ground	Turn signal LH	Output	Ignition switch ON	Turn signal switch OFF 0 V
				Turn signal switch LH	
61 (W/L)	Ground	Turn signal RH	Output	Ignition switch ON	Turn signal switch OFF 0 V
				Turn signal switch RH	
63 (BR)	Ground	Interior room lamp control signal	Output	Interior room lamp	OFF 12 V
				ON	0 V
65 (V)	Ground	All doors LOCK	Output	All doors	LOCK (Actuator is activat- ed) 12 V
				Other than LOCK (Actua- tor is not activated)	0 V
66 (G)	Ground	Passenger door and rear door UNLOCK	Output	Passenger door and rear door	UNLOCK (Actuator is acti- vated) 12 V
				Other than UNLOCK (Ac- tuator is not activated)	0 V
67 (B)	Ground	Ground	Output	Ignition switch ON	0 V
68 (L)	Ground	P/W power supply (IGN)	Output	Ignition switch ON	12 V
69 (P)	Ground	P/W power supply (BAT)	Output	Ignition switch OFF	12 V
70 (Y)	Ground	Battery power sup- ply	Input	Ignition switch OFF	Battery voltage

A  
B  
C  
D  
E  
F  
G  
H  
I  
J  
PWC  
L  
M  
N  
O  
P

# BCM (BODY CONTROL MODULE)

< ECU DIAGNOSIS INFORMATION >

## WITHOUT INTELLIGENT KEY : Wiring Diagram - BCM -

INFOID:0000000110230398

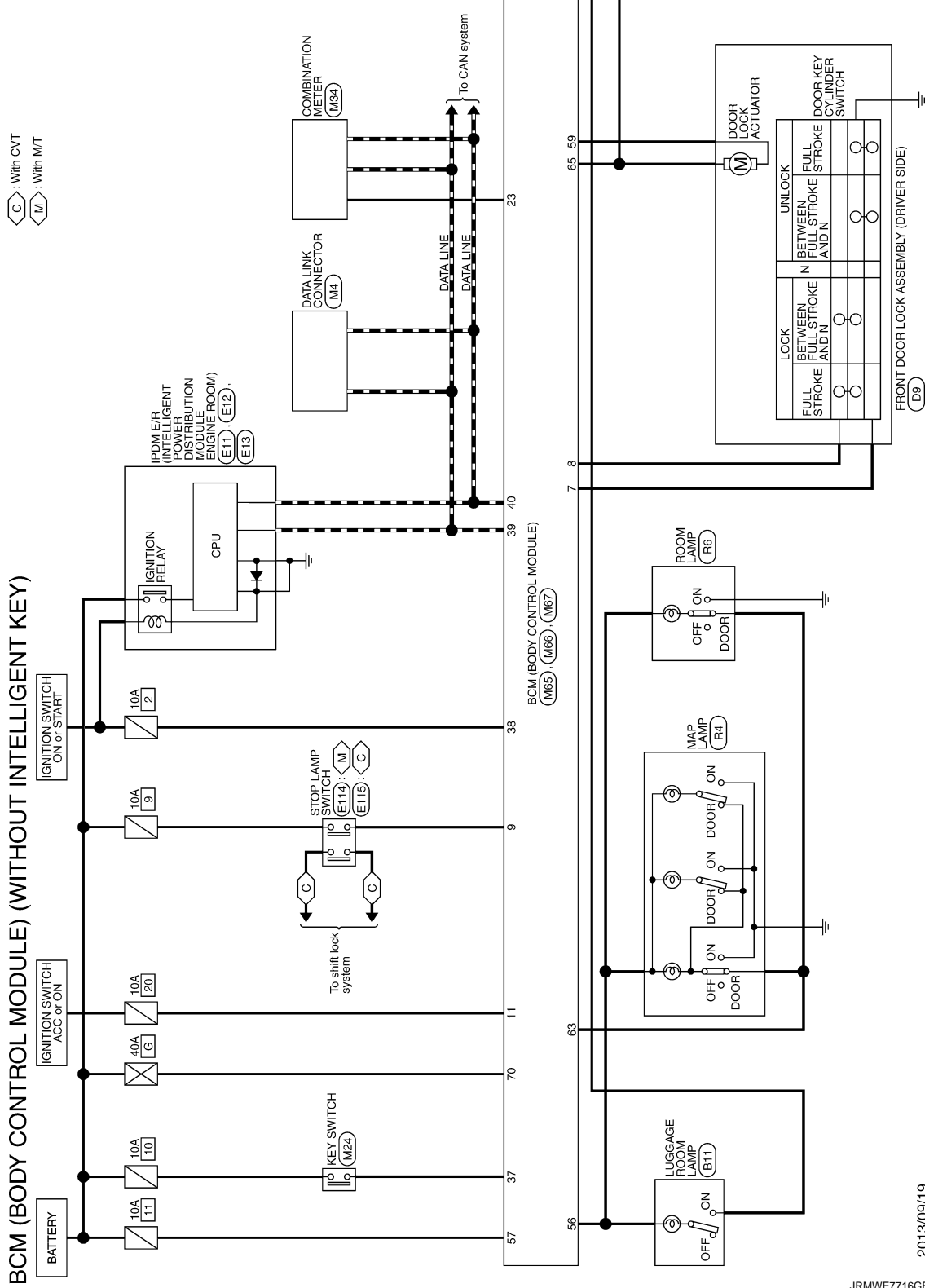

2013/09/19

JRMWE7716GB



# BCM (BODY CONTROL MODULE)

< ECU DIAGNOSIS INFORMATION >

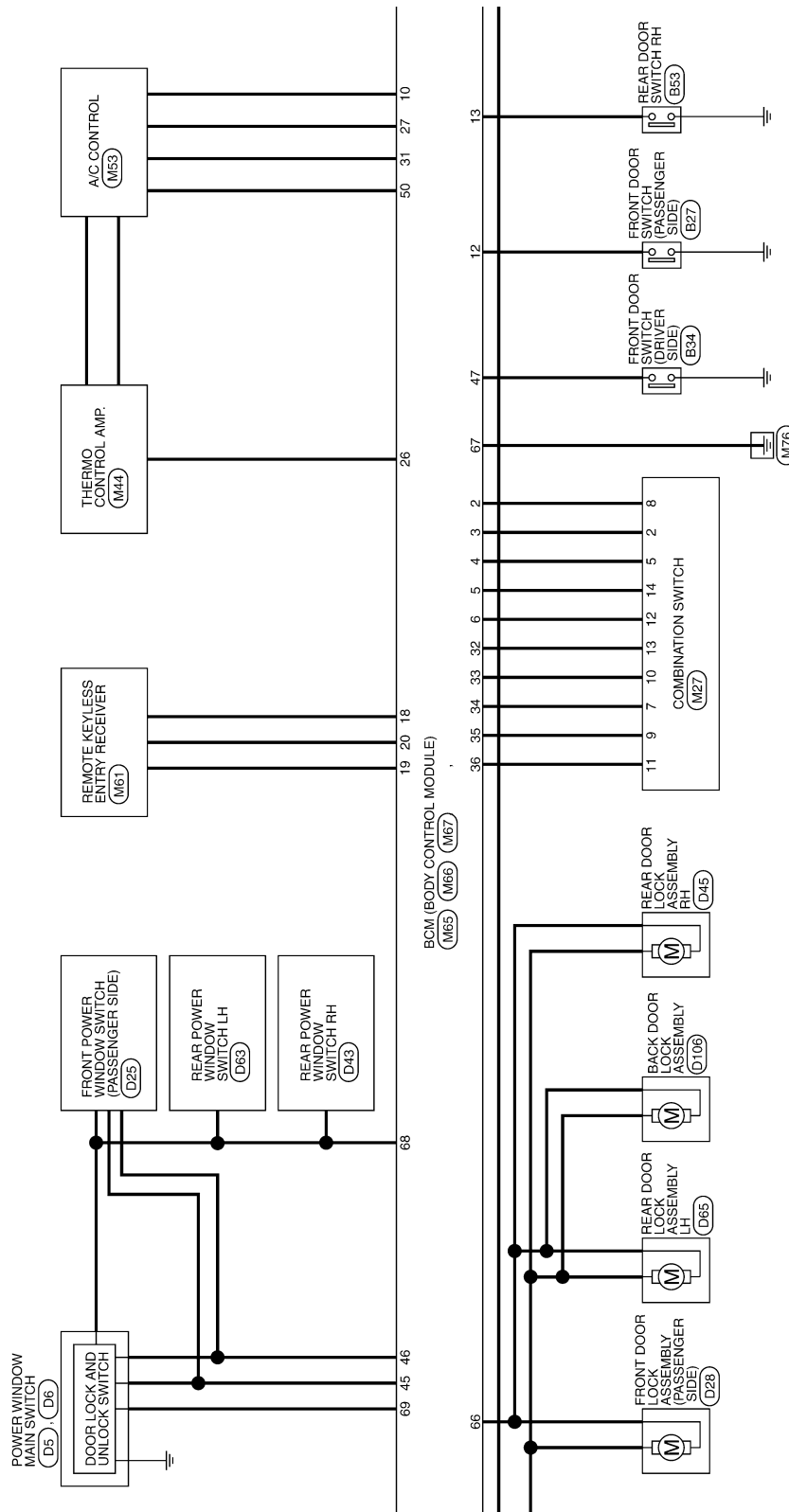

JRMWE7717GB

A  
B  
C  
D  
E  
F  
G  
H  
I  
J  
L  
M  
N  
O  
P

PWC

# BCM (BODY CONTROL MODULE)

< ECU DIAGNOSIS INFORMATION >

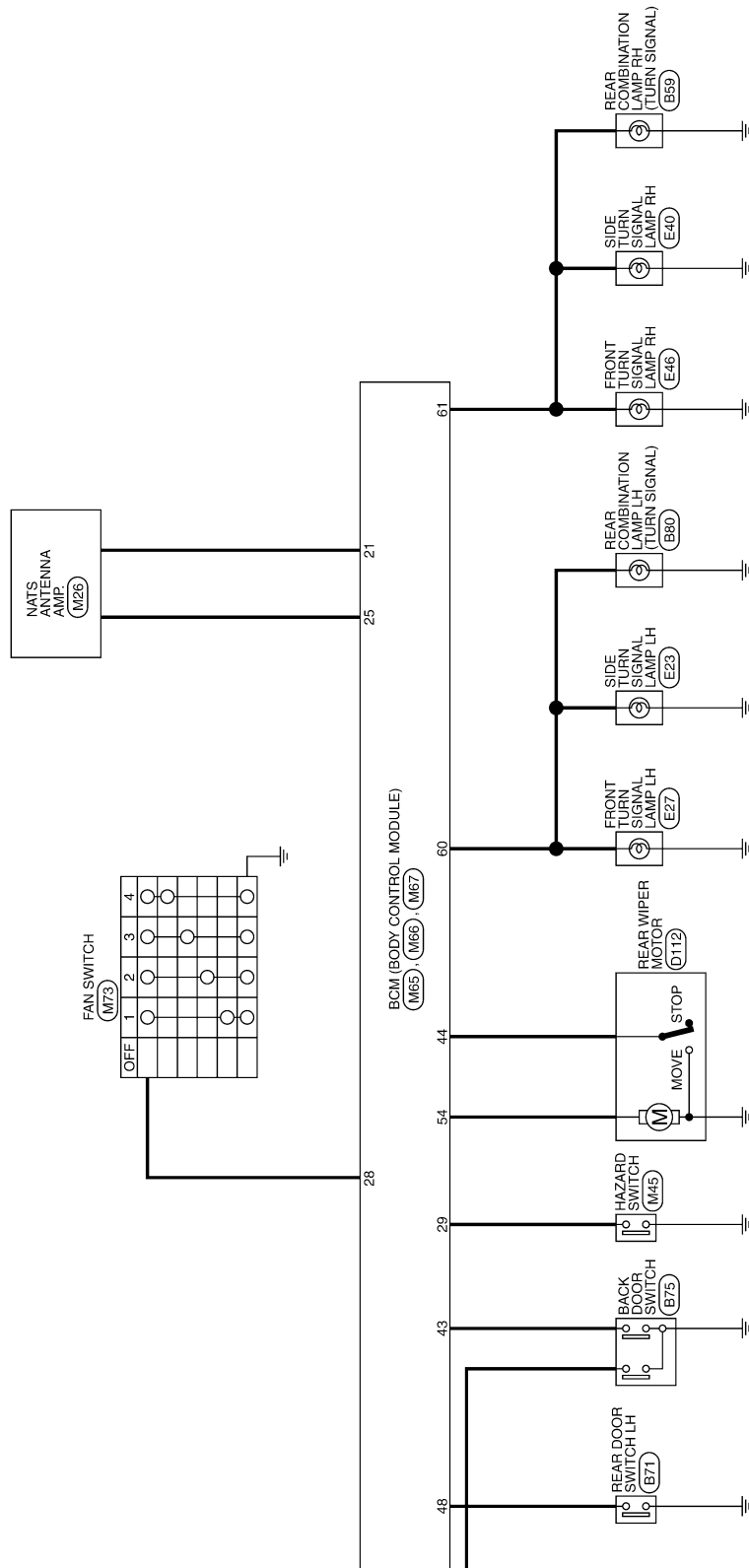



JRMWE7718GB

# BCM (BODY CONTROL MODULE)

< ECU DIAGNOSIS INFORMATION >



**BCM (BODY CONTROL MODULE)**

Connector No.	B11
Connector Name	LUGGAGE ROOM LAMP
Connector Type	CJ04FW

Terminal No.	Color Of Wire	Signal Name [Specification]
1	Y	-
3	L	-



Connector No.	B27
Connector Name	FRONT DOOR SWITCH (PASSENGER SIDE)
Connector Type	TH04FW-NH

Terminal No.	Color Of Wire	Signal Name [Specification]
1	Y	-
3	L	-



**BCM (WITHOUT INTELLIGENT KEY)**

Connector No.	B34
Connector Name	FRONT DOOR SWITCH (DRIVER SIDE)
Connector Type	TH04FW-NH



Terminal No.	Color Of Wire	Signal Name [Specification]
1	Y	-
3	B	-
4	W	-
5	R	-
6	V	-

Connector No.	B71
Connector Name	REAR DOOR SWITCH-LH
Connector Type	TH04FW-NH



Terminal No.	Color Of Wire	Signal Name [Specification]
1	Y	-
3	B	-
4	W	-
5	R	-
6	V	-

Connector No.	B53
Connector Name	REAR DOOR SWITCH-RH
Connector Type	TH04FW-NH



Terminal No.	Color Of Wire	Signal Name [Specification]
3	LG	-

Connector No.	B59
Connector Name	REAR COMBINATION LAMP RH
Connector Type	RS06FB-FR



Terminal No.	Color Of Wire	Signal Name [Specification]
3	LG	-

Connector No.	B80
Connector Name	REAR COMBINATION LAMP LH
Connector Type	RS06FB-FR

Terminal No.	Color Of Wire	Signal Name [Specification]
1	Y	-
3	B	-
4	B	-
5	R	-
6	GR	-

Connector No.	B75
Connector Name	BACK DOOR SWITCH
Connector Type	TH04FW-NH

Terminal No.	Color Of Wire	Signal Name [Specification]
2	L	-
3	W	-

Connector No.	B5
Connector Name	POWER WINDOW MAIN SWITCH
Connector Type	NS16FW-CS



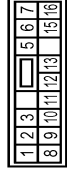









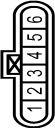

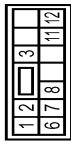
Terminal No.	Color Of Wire	Signal Name [Specification]
1	R	-
2	LG	-
3	O	-
5	Y	-
6	V	-
7	LG	-
8	BR	-
9	V	-
10	L	-
11	GR	-
12	SB	-
13	W	-
15	G	-
16	W	-

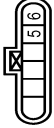
A  
B  
C  
D  
E  
F  
G  
H  
I  
J  
L  
M  
N  
O  
P

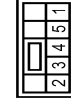
PWC

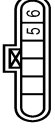
# BCM (BODY CONTROL MODULE)

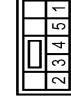





< ECU DIAGNOSIS INFORMATION >

BCM (BODY CONTROL MODULE) (WITHOUT INTELLIGENT KEY)		
Connector No.	D6	
Connector Name	POWER WINDOW MAIN SWITCH	
Connector Type	NS08FM-CS	
 		
Terminal Color Of No.	Wire	Signal Name [Specification]
17	B	-
18	GR	-
19	P	-
Connector No.	D9	
Connector Name	FRONT DOOR LOCK ASSEMBLY (DRIVER SIDE)	
Connector Type	E06F-GY-RS	
 		
Terminal Color Of No.	Wire	Signal Name [Specification]
1	V	-
2	SB	-
3	G	-
4	B	-
5	L	-
6	W	-
Connector No.	D25	
Connector Name	FRONT POWER WINDOW SWITCH (PASSENGER SIDE)	
Connector Type	NS12FM-CS	
 		
Terminal Color Of No.	Wire	Signal Name [Specification]
1	GR	-
2	BR	-
3	B	-
6	Y	-
7	R	-
8	L	-
11	SB	-
12	W	-
Connector No.	D28	
Connector Name	FRONT DOOR LOCK ASSEMBLY (PASSENGER SIDE)	
Connector Type	E06F-GY-RS	
 		
Terminal Color Of No.	Wire	Signal Name [Specification]
5	V	-
6	Y	-
Connector No.	D43	
Connector Name	REAR POWER WINDOW SWITCH RH	
Connector Type	NS08FM-CS	
 		
Terminal Color Of No.	Wire	Signal Name [Specification]
1	L	-
2	BR	-
3	O	-
4	G	-
5	R	-
Connector No.	D45	
Connector Name	REAR DOOR LOCK ASSEMBLY RH	
Connector Type	E06F-GY-RS	
 		
Terminal Color Of No.	Wire	Signal Name [Specification]
5	W	-
6	P	-
Connector No.	D63	
Connector Name	REAR POWER WINDOW SWITCH LH	
Connector Type	NS08FM-CS	
 		
Terminal Color Of No.	Wire	Signal Name [Specification]
1	L	-
2	BR	-
3	O	-
4	G	-
5	R	-
Connector No.	D65	
Connector Name	REAR DOOR LOCK ASSEMBLY LH	
Connector Type	E06F-GY-RS	
 		
Terminal Color Of No.	Wire	Signal Name [Specification]
1	V	-
2	G	-

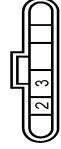
JRMWE7827GB

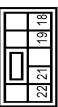
# BCM (BODY CONTROL MODULE)

< ECU DIAGNOSIS INFORMATION >

BCM (BODY CONTROL MODULE) (WITHOUT INTELLIGENT KEY)																																								
<table border="1"> <tr><td>Connector No.</td><td>D106</td></tr> <tr><td>Connector Name</td><td>BACK DOOR LOCK ASSEMBLY</td></tr> <tr><td>Connector Type</td><td>FEA04FB-FH2-LC</td></tr> </table> 	Connector No.	D106	Connector Name	BACK DOOR LOCK ASSEMBLY	Connector Type	FEA04FB-FH2-LC	<table border="1"> <tr><td>Terminal No.</td><td>2</td><td>3</td></tr> <tr><td>Color</td><td>GR</td><td>Y</td></tr> <tr><td>Wire</td><td>-</td><td>-</td></tr> </table>	Terminal No.	2	3	Color	GR	Y	Wire	-	-	<table border="1"> <tr><td>Signal Name [Specification]</td><td>-</td></tr> </table>	Signal Name [Specification]	-																					
Connector No.	D106																																							
Connector Name	BACK DOOR LOCK ASSEMBLY																																							
Connector Type	FEA04FB-FH2-LC																																							
Terminal No.	2	3																																						
Color	GR	Y																																						
Wire	-	-																																						
Signal Name [Specification]	-																																							
<table border="1"> <tr><td>Connector No.</td><td>D112</td></tr> <tr><td>Connector Name</td><td>REAR WIPER MOTOR</td></tr> <tr><td>Connector Type</td><td>CJ04FM-TV</td></tr> </table> 	Connector No.	D112	Connector Name	REAR WIPER MOTOR	Connector Type	CJ04FM-TV	<table border="1"> <tr><td>Terminal No.</td><td>1</td><td>3</td><td>4</td></tr> <tr><td>Color</td><td>P</td><td>BR</td><td>LG</td></tr> <tr><td>Wire</td><td>-</td><td>-</td><td>-</td></tr> </table>	Terminal No.	1	3	4	Color	P	BR	LG	Wire	-	-	-	<table border="1"> <tr><td>Signal Name [Specification]</td><td>-</td></tr> </table>	Signal Name [Specification]	-																		
Connector No.	D112																																							
Connector Name	REAR WIPER MOTOR																																							
Connector Type	CJ04FM-TV																																							
Terminal No.	1	3	4																																					
Color	P	BR	LG																																					
Wire	-	-	-																																					
Signal Name [Specification]	-																																							
<table border="1"> <tr><td>Connector No.</td><td>E11</td></tr> <tr><td>Connector Name</td><td>POWER INTELLIGENT POWER DISTRIBUTION MODULE (ENGINE ROOM)</td></tr> <tr><td>Connector Type</td><td>M06FELC</td></tr> </table> 	Connector No.	E11	Connector Name	POWER INTELLIGENT POWER DISTRIBUTION MODULE (ENGINE ROOM)	Connector Type	M06FELC	<table border="1"> <tr><td>Terminal No.</td><td>9</td><td>10</td><td>13</td></tr> <tr><td>Color</td><td>BTW</td><td>W</td><td>-</td></tr> <tr><td>Wire</td><td>-</td><td>-</td><td>-</td></tr> </table>	Terminal No.	9	10	13	Color	BTW	W	-	Wire	-	-	-	<table border="1"> <tr><td>Signal Name [Specification]</td><td>-</td></tr> </table>	Signal Name [Specification]	-																		
Connector No.	E11																																							
Connector Name	POWER INTELLIGENT POWER DISTRIBUTION MODULE (ENGINE ROOM)																																							
Connector Type	M06FELC																																							
Terminal No.	9	10	13																																					
Color	BTW	W	-																																					
Wire	-	-	-																																					
Signal Name [Specification]	-																																							
<table border="1"> <tr><td>Connector No.</td><td>E12</td></tr> <tr><td>Connector Name</td><td>POWER INTELLIGENT POWER DISTRIBUTION MODULE (ENGINE ROOM)</td></tr> <tr><td>Connector Type</td><td>NS08FBCS</td></tr> </table> 	Connector No.	E12	Connector Name	POWER INTELLIGENT POWER DISTRIBUTION MODULE (ENGINE ROOM)	Connector Type	NS08FBCS	<table border="1"> <tr><td>Terminal No.</td><td>18</td><td>19</td><td>21</td><td>22</td></tr> <tr><td>Color</td><td>Y</td><td>BTW</td><td>W</td><td>V</td></tr> <tr><td>Wire</td><td>-</td><td>-</td><td>-</td><td>-</td></tr> </table>	Terminal No.	18	19	21	22	Color	Y	BTW	W	V	Wire	-	-	-	-	<table border="1"> <tr><td>Signal Name [Specification]</td><td>-</td></tr> </table>	Signal Name [Specification]	-															
Connector No.	E12																																							
Connector Name	POWER INTELLIGENT POWER DISTRIBUTION MODULE (ENGINE ROOM)																																							
Connector Type	NS08FBCS																																							
Terminal No.	18	19	21	22																																				
Color	Y	BTW	W	V																																				
Wire	-	-	-	-																																				
Signal Name [Specification]	-																																							
<table border="1"> <tr><td>Connector No.</td><td>E13</td></tr> <tr><td>Connector Name</td><td>POWER INTELLIGENT POWER DISTRIBUTION MODULE (ENGINE ROOM)</td></tr> <tr><td>Connector Type</td><td>TH12FM-NH</td></tr> </table> 	Connector No.	E13	Connector Name	POWER INTELLIGENT POWER DISTRIBUTION MODULE (ENGINE ROOM)	Connector Type	TH12FM-NH	<table border="1"> <tr><td>Terminal No.</td><td>24</td><td>25</td><td>26</td><td>27</td><td>28</td><td>30</td><td>31</td><td>33</td><td>34</td></tr> <tr><td>Color</td><td>G</td><td>Y</td><td>P</td><td>L</td><td>P</td><td>SB</td><td>W</td><td>O</td><td>R</td></tr> <tr><td>Wire</td><td>-</td><td>-</td><td>-</td><td>-</td><td>-</td><td>-</td><td>-</td><td>-</td><td>-</td></tr> </table>	Terminal No.	24	25	26	27	28	30	31	33	34	Color	G	Y	P	L	P	SB	W	O	R	Wire	-	-	-	-	-	-	-	-	-	<table border="1"> <tr><td>Signal Name [Specification]</td><td>-</td></tr> </table>	Signal Name [Specification]	-
Connector No.	E13																																							
Connector Name	POWER INTELLIGENT POWER DISTRIBUTION MODULE (ENGINE ROOM)																																							
Connector Type	TH12FM-NH																																							
Terminal No.	24	25	26	27	28	30	31	33	34																															
Color	G	Y	P	L	P	SB	W	O	R																															
Wire	-	-	-	-	-	-	-	-	-																															
Signal Name [Specification]	-																																							
<table border="1"> <tr><td>Connector No.</td><td>E23</td></tr> <tr><td>Connector Name</td><td>SIDE TURN SIGNAL LAMP LH</td></tr> <tr><td>Connector Type</td><td>STL02FW</td></tr> </table> 	Connector No.	E23	Connector Name	SIDE TURN SIGNAL LAMP LH	Connector Type	STL02FW	<table border="1"> <tr><td>Terminal No.</td><td>1</td><td>2</td></tr> <tr><td>Color</td><td>W</td><td>BY</td></tr> <tr><td>Wire</td><td>-</td><td>-</td></tr> </table>	Terminal No.	1	2	Color	W	BY	Wire	-	-	<table border="1"> <tr><td>Signal Name [Specification]</td><td>-</td></tr> </table>	Signal Name [Specification]	-																					
Connector No.	E23																																							
Connector Name	SIDE TURN SIGNAL LAMP LH																																							
Connector Type	STL02FW																																							
Terminal No.	1	2																																						
Color	W	BY																																						
Wire	-	-																																						
Signal Name [Specification]	-																																							
<table border="1"> <tr><td>Connector No.</td><td>E27</td></tr> <tr><td>Connector Name</td><td>FRONT TURN SIGNAL LAMP LH</td></tr> <tr><td>Connector Type</td><td>RS02FB</td></tr> </table> 	Connector No.	E27	Connector Name	FRONT TURN SIGNAL LAMP LH	Connector Type	RS02FB	<table border="1"> <tr><td>Terminal No.</td><td>1</td><td>2</td></tr> <tr><td>Color</td><td>L</td><td>BTW</td></tr> <tr><td>Wire</td><td>-</td><td>-</td></tr> </table>	Terminal No.	1	2	Color	L	BTW	Wire	-	-	<table border="1"> <tr><td>Signal Name [Specification]</td><td>-</td></tr> </table>	Signal Name [Specification]	-																					
Connector No.	E27																																							
Connector Name	FRONT TURN SIGNAL LAMP LH																																							
Connector Type	RS02FB																																							
Terminal No.	1	2																																						
Color	L	BTW																																						
Wire	-	-																																						
Signal Name [Specification]	-																																							
<table border="1"> <tr><td>Connector No.</td><td>E40</td></tr> <tr><td>Connector Name</td><td>SIDE TURN SIGNAL LAMP RH</td></tr> <tr><td>Connector Type</td><td>STL02FW</td></tr> </table> 	Connector No.	E40	Connector Name	SIDE TURN SIGNAL LAMP RH	Connector Type	STL02FW	<table border="1"> <tr><td>Terminal No.</td><td>1</td><td>2</td></tr> <tr><td>Color</td><td>W</td><td>BY</td></tr> <tr><td>Wire</td><td>-</td><td>-</td></tr> </table>	Terminal No.	1	2	Color	W	BY	Wire	-	-	<table border="1"> <tr><td>Signal Name [Specification]</td><td>-</td></tr> </table>	Signal Name [Specification]	-																					
Connector No.	E40																																							
Connector Name	SIDE TURN SIGNAL LAMP RH																																							
Connector Type	STL02FW																																							
Terminal No.	1	2																																						
Color	W	BY																																						
Wire	-	-																																						
Signal Name [Specification]	-																																							

A  
B  
C  
D  
E  
F  
G  
H  
I  
J  
L  
M  
N  
O  
P



PWC

# BCM (BODY CONTROL MODULE)

< ECU DIAGNOSIS INFORMATION >



**BCM (BODY CONTROL MODULE) (WITHOUT INTELLIGENT KEY)**

Connector No. E146  
 Connector Name FRONT TURN SIGNAL LAMP RH  
 Connector Type RS02FB



Terminal No.	Color Of Wire	Signal Name [Specification]
1	W	-
2	BY	-

Connector No. E114  
 Connector Name STOP LAMP SWITCH  
 Connector Type M02PE-LC

Terminal No.	Color Of Wire	Signal Name [Specification]
1	W	-
2	BY	-

Connector No. E115  
 Connector Name STOP LAMP SWITCH  
 Connector Type M04FW-LC



Terminal No.	Color Of Wire	Signal Name [Specification]
1	V	-
2	W	-
3	O	-
4	G	-

Connector No. M4  
 Connector Name DATA LINK CONNECTOR  
 Connector Type BD16FW

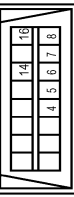

Terminal No.	Color Of Wire	Signal Name [Specification]
4	B	-
5	B	-
6	L	-
7	GR/R	-
8	O	-
14	P	-
16	LG/R	-

Connector No. M24  
 Connector Name KEY SWITCH  
 Connector Type TK06MGY



Terminal No.	Color Of Wire	Signal Name [Specification]
1	RW	-
2	LG/R	-

Connector No. M26  
 Connector Name NATS ANTENNA AMP.  
 Connector Type TH04FW-NH



Terminal No.	Color Of Wire	Signal Name [Specification]
1	Y	BAT
2	P/L	CLK
3	B	GND [Without Intelligent Key]
3	LG	DATA [With Intelligent Key]
4	B	GND [With Intelligent Key]
4	LG	DATA [Without Intelligent Key]

Connector No. M27  
 Connector Name COMBINATION SWITCH  
 Connector Type TH04FW-NH

Terminal No.	Color Of Wire	Signal Name [Specification]
1	O/B	WASHER (RR)
2	GR	OUTPUT 4
3	RG	WASHER (FR)
4	W	IGN
6	LY	OUTPUT 3
6	B	GROUND
7	V	INPUT 3
8	BRW	OUTPUT 5
9	R/L	INPUT 2
10	Y/L	INPUT 4
11	L/O	INPUT 1
12	L/R	OUTPUT 1
13	LG	INPUT 5
14	G	OUTPUT 2

Connector No. M34  
 Connector Name COMBINATION METER  
 Connector Type TH04FW-NH

Terminal No.	Color Of Wire	Signal Name [Specification]
1	L	CANH
2	P	CANL
3	V	VEHICLE SPEED SIGNAL (2-PULSE)
4	L	VEHICLE SPEED SIGNAL (8-PULSE) [Immo/NWV]
4	VR	VEHICLE SPEED SIGNAL (8-PULSE) [With NWV]
6	BRY	FUEL LEVEL SENSOR SIGNAL

JRMWE7829GB

# BCM (BODY CONTROL MODULE)

< ECU DIAGNOSIS INFORMATION >

## BCM (BODY CONTROL MODULE) (WITHOUT INTELLIGENT KEY)

Connector No.	Signal Name	Terminal No.	Wire
7	AIR BAG SIGNAL		
8	OVERDRIVE CONTROL SWITCH SIGNAL		
9	SEAT BELT BUCKLE SWITCH SIGNAL (DRIVER SIDE)		
10	PARKING BRAKE SWITCH SIGNAL		
11	BRAKE FLUID LEVEL SWITCH SIGNAL		
13	ILLUMINATION CONTROL SIGNAL		
15	ACC POWER SUPPLY		
18	SECURITY SIGNAL		
19	AMBIENT SENSOR SIGNAL		
20	AMBIENT SENSOR GROUND		
21	GROUND		
22	GROUND		
23	GROUND		
24	FUEL LEVEL SENSOR GROUND		
25	VDC GROUND		
27	BATTERY POWER SUPPLY		
28	IGNITION SIGNAL		
29	PASSENGER SEAT BELT WARNING SIGNAL		
31	AC AUTO AMP CONNECTOR (ELECTOR) SIGNAL		
35	ENGINE COOLANT TEMPERATURE SIGNAL		
38	ALTERNATOR SIGNAL		

Connector No.	M44
Connector Name	THERMO CONTROL AMP.
Connector Type	SUBFW



Terminal No.	Color Of Wire	Signal Name [Specification]
1	Y	-
2	GR	-
3	B	-
4	V	-
5	BW	-

Connector No.	M45
Connector Name	HAZARD SWITCH
Connector Type	TK04FW



Terminal No.	Color Of Wire	Signal Name [Specification]
1	B	-
2	LW	-
3	W	-
4	BR	-

Connector No.	M53
Connector Name	AC CONTROL
Connector Type	THH6FW-NH



Terminal No.	Color Of Wire	Signal Name [Specification]
1	W	-
4	R	-
5	W/L	-
6	G/Y	-
8	G	-
9	BR	-
10	BW	-
11	V	-
12	Y/R	-
13	SB	-
14	Y	-
15	B	-
16	L	-

Connector No.	M61
Connector Name	REMOTE KEYLESS ENTRY RECEIVER
Connector Type	TK04FW



Terminal No.	Color Of Wire	Signal Name [Specification]
1	V	-
2	G/Y	-
4	BR	-

Connector No.	M65
Connector Name	BCM (BODY CONTROL MODULE)
Connector Type	TH40FW-NH

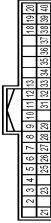

Terminal No.	Color Of Wire	Signal Name [Specification]
2	BR/W	COMBI SW INPUT 5
3	GR	COMBI SW INPUT 4
4	L/Y	COMBI SW INPUT 3
5	G	COMBI SW INPUT 2
6	L/R	COMBI SW INPUT 1
7	W/R	KEY CYL LOCK SW
8	W/B	KEY CYL LOCK SW
9	R	STOP LAMP SW
10	W/L	REAR WINDOW DEFOGGER SW
11	L/Y	ACC POWER SUPPLY
12	SB	PASSENGER DOOR SW
13	GB/L	REAR RH DOOR SW
14	V	RECEIVER SENSOR GND
15	BR	KEYLESS ENTRY RECEIVER POWER SUPPLY
16	G/Y	KEYLESS ENTRY RECEIVER COMM
17	P/L	NAIS ANTENNA AMP.
18	RY	SECURITY INDICATOR LAMP

Terminal No.	Color Of Wire	Signal Name [Specification]
25	LG	NAIS ANTENNA AMP.
26	GR	THERMO CONTROL AMP.
27	Y/G	A/C SW
28	GW	BLOWER FAN SW
29	L/W	HAZARD SW
31	G/Y	FR DEFROSTER SW
32	LG	COMBI SW OUTPUT 5
33	Y/L	COMBI SW OUTPUT 4
34	W	COMBI SW OUTPUT 3
35	R/L	COMBI SW OUTPUT 2
36	L/O	COMBI SW OUTPUT 1
37	RAW	KEY SWITCH
38	O	IGNITION POWER SUPPLY
39	L	CANH
40	P	CANL

Connector No.	M66
Connector Name	BCM (BODY CONTROL MODULE)
Connector Type	FE409FW-FH46-SA

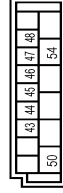

Terminal No.	Color Of Wire	Signal Name [Specification]
43	W	BACK DOOR SW
44	LG	REAR WIPER STOP POSITION
45	GR	CENTRAL DOOR LOCK SW
46	BR	CENTRAL DOOR UNLOCK SW
47	BRY	DRIVER DOOR SW
48	W/G	REAR LH DOOR SW
50	SB	A/C INDICATOR OUTPUT
54	LG	REAR WIPER OUTPUT

A  
B  
C  
D  
E  
F  
G  
H  
I  
J  
K  
L  
M  
N  
O  
P

PWC

# BCM (BODY CONTROL MODULE)

< ECU DIAGNOSIS INFORMATION >

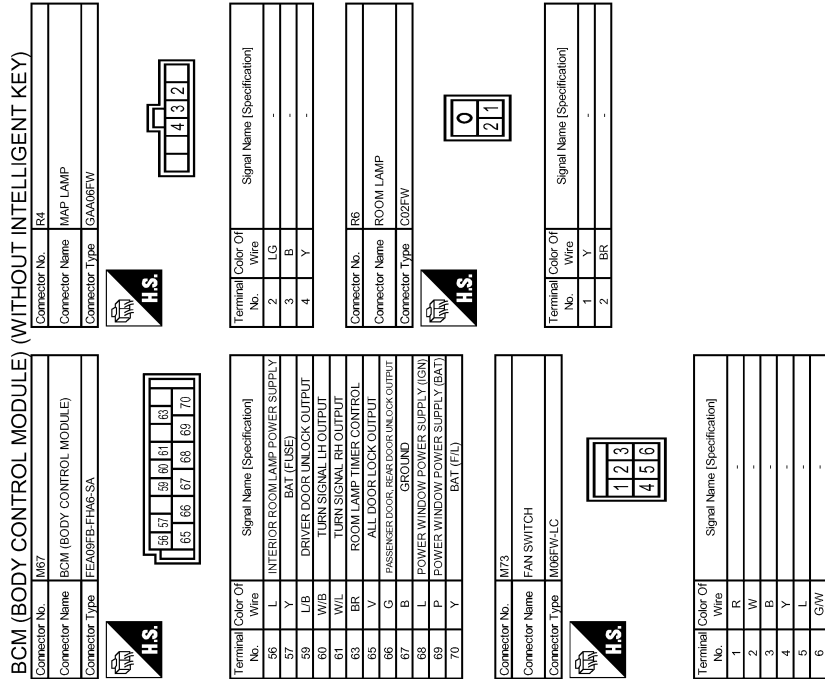

## WITHOUT INTELLIGENT KEY : Fail-safe

**FAIL-SAFE CONTROL BY DTC**  
 BCM performs fail-safe control when any DTC are detected.

JRMWE7831GB  
 INFOID:0000000010230399



# BCM (BODY CONTROL MODULE)

## < ECU DIAGNOSIS INFORMATION >

Display contents of CONSULT	Fail-safe	Cancellation
B2190: NATS ANTENNA AMP	Inhibit engine cranking	Erase DTC
B2191: DIFFERENCE OF KEY	Inhibit engine cranking	Erase DTC
B2192: ID DISCORD BCM-ECM	Inhibit engine cranking	Erase DTC
B2193: CHAIN OF BCM-ECM	Inhibit engine cranking	Erase DTC
B2195: ANTI SCANNING	Inhibit engine cranking	Ignition switch ON → OFF

### REAR WIPER MOTOR PROTECTION

BCM detects the rear wiper stopping position according to the rear wiper auto stop signal.

When the rear wiper auto stop signal does not change more than 5 seconds while driving the rear wiper, BCM stops power supply to protect the rear wiper motor.

Condition of cancellation

1. Pass more than 1 minute after the rear wiper stop.
2. Turn rear wiper switch OFF.
3. Operate the rear wiper switch or rear washer switch.

### WITHOUT INTELLIGENT KEY : DTC Inspection Priority Chart

INFOID:0000000010230400

If some DTCs are displayed at the same time, perform inspections one by one based on the following priority chart.

Priority	DTC
1	<ul style="list-style-type: none"> <li>• U1000: CAN COMM</li> <li>• U1010: CONTROL UNIT (CAN)</li> </ul>
2	<ul style="list-style-type: none"> <li>• B2190: NATS ANTENNA AMP</li> <li>• B2191: DIFFERENCE OF KEY</li> <li>• B2192: ID DISCORD BCM-ECM</li> <li>• B2193: CHAIN OF BCM-ECM</li> <li>• B2195: ANTI SCANNING</li> </ul>
3	C1735: IGN CIRCUIT OPEN
4	<ul style="list-style-type: none"> <li>• C1704: LOW PRESSURE FL</li> <li>• C1705: LOW PRESSURE FR</li> <li>• C1706: LOW PRESSURE RR</li> <li>• C1707: LOW PRESSURE RL</li> <li>• C1708: [NO DATA] FL</li> <li>• C1709: [NO DATA] FR</li> <li>• C1710: [NO DATA] RR</li> <li>• C1711: [NO DATA] RL</li> <li>• C1716: [PRESSDATA ERR] FL</li> <li>• C1717: [PRESSDATA ERR] FR</li> <li>• C1718: [PRESSDATA ERR] RR</li> <li>• C1719: [PRESSDATA ERR] RL</li> <li>• C1729: VHCL SPEED SIG ERR</li> </ul>

PWC

### WITHOUT INTELLIGENT KEY : DTC Index

INFOID:0000000010230401

#### NOTE:

Details of time display

- CRNT: Displays when there is a malfunction now or after returning to the normal condition until turning ignition switch OFF → ON again.
- 1 - 39: Displayed if any previous malfunction is present when current condition is normal. It increases like 1 → 2 → 3...38 → 39 after returning to the normal condition whenever ignition switch OFF → ON. The counter remains at 39 even if the number of cycles exceeds it. It is counted from 1 again when turning ignition switch OFF → ON after returning to the normal condition if the malfunction is detected again.

## BCM (BODY CONTROL MODULE)

< ECU DIAGNOSIS INFORMATION >

CONSULT display	Fail-safe	Tire pressure monitor warn- ing lamp ON	Reference
U1000: CAN COMM	—	—	<a href="#">BCS-120</a>
U1010: CONTROL UNIT (CAN)	—	—	<a href="#">BCS-121</a>
B2190: NATS ANTENNA AMP	×	—	<a href="#">SEC-197</a>
B2191: DIFFERENCE OF KEY	×	—	<a href="#">SEC-200</a>
B2192: ID DISCORD BCM-ECM	×	—	<a href="#">SEC-201</a>
B2193: CHAIN OF BCM-ECM	×	—	<a href="#">SEC-202</a>
B2195: ANTI SCANNING	×	—	<a href="#">SEC-203</a>
C1704: LOW PRESSURE FL	—	×	<a href="#">WT-26</a>
C1705: LOW PRESSURE FR	—	×	
C1706: LOW PRESSURE RR	—	×	
C1707: LOW PRESSURE RL	—	×	
C1708: [NO DATA] FL	—	×	<a href="#">WT-28</a>
C1709: [NO DATA] FR	—	×	
C1710: [NO DATA] RR	—	×	
C1711: [NO DATA] RL	—	×	
C1716: [PRESS DATA ERR] FL	—	×	<a href="#">WT-31</a>
C1717: [PRESS DATA ERR] FR	—	×	
C1718: [PRESS DATA ERR] RR	—	×	
C1719: [PRESS DATA ERR] RL	—	×	
C1729: VHCL SPEED SIG ERR	—	×	<a href="#">WT-33</a>
C1735: IGN CIRCUIT OPEN	—	—	<a href="#">BCS-122</a>

# POWER WINDOW MAIN SWITCH

< ECU DIAGNOSIS INFORMATION >

## POWER WINDOW MAIN SWITCH

Reference Value

INFOID:000000009950893

### TERMINAL LAYOUT

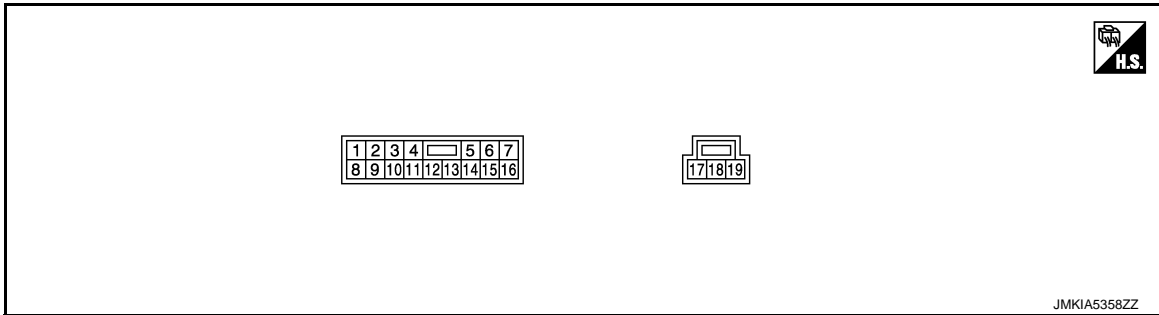

### PHYSICAL VALUES

Terminal No. (Wire color)		Description		Condition	Voltage [V] (Approx.)
+	-	Signal name	Input/ Output		
1 (R)	Ground	Rear power window motor LH UP signal	Output	When rear LH switch in power window main switch is in UP operation.	Battery voltage
2 (LG)	Ground	Encoder ground	—	—	0
3 (O)	Ground	Rear power window motor LH DOWN signal	Output	When rear LH switch in power window main switch is in DOWN operation.	Battery voltage
5 (Y)	Ground	Rear power window motor RH DOWN signal	Output	When rear RH switch in power window main switch is in DOWN operation.	Battery voltage
7 (LG)	Ground	Rear power window motor RH UP signal	Output	When rear RH switch in power window main switch is in UP operation.	Battery voltage
8 (BR)	Ground	Front power window motor (driver side) UP signal	Output	When front LH switch in power window main switch is in UP operation.	Battery voltage
9 (V)	Ground	Encoder pulse signal 2	Input	When front power window motor (driver side) operates.	 JMKIA0070GB
10 (L)	Ground	Ignition switch power supply	Input	Ignition switch ON	Battery voltage
				Other than above	0
11 (GR)	Ground	Front power window motor (driver side) DOWN signal	Output	When front LH switch in power window main switch is in DOWN operation.	Battery voltage
12 (SB)	Ground	Front power window motor (passenger side) DOWN signal	Output	When front RH switch in power window main switch is in DOWN operation.	Battery voltage

# POWER WINDOW MAIN SWITCH

## < ECU DIAGNOSIS INFORMATION >

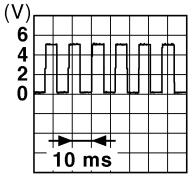
Terminal No. (Wire color)		Description		Condition	Voltage [V] (Approx.)
+	-	Signal name	Input/ Output		
13 (W)	Ground	Encoder pulse signal 1	Input	When front power window motor (driver side) operates.	 <p style="text-align: right; font-size: small;">JMKIA0070GB</p>
15 (G)	Ground	Encoder power supply	Output	Ignition switch ON.	Battery voltage
16 (W)	Ground	Front power window motor (passenger side) UP signal	Output	When front RH switch in power window main switch is in UP operation.	Battery voltage
17 (B)	Ground	Ground	—	—	0
19 (P)	Ground	Battery power supply	Input	Ignition switch OFF	Battery voltage

# POWER WINDOW MAIN SWITCH

< ECU DIAGNOSIS INFORMATION >

## Wiring Diagram - POWER WINDOW CONTROL SYSTEM -

INFOID:0000000009950894

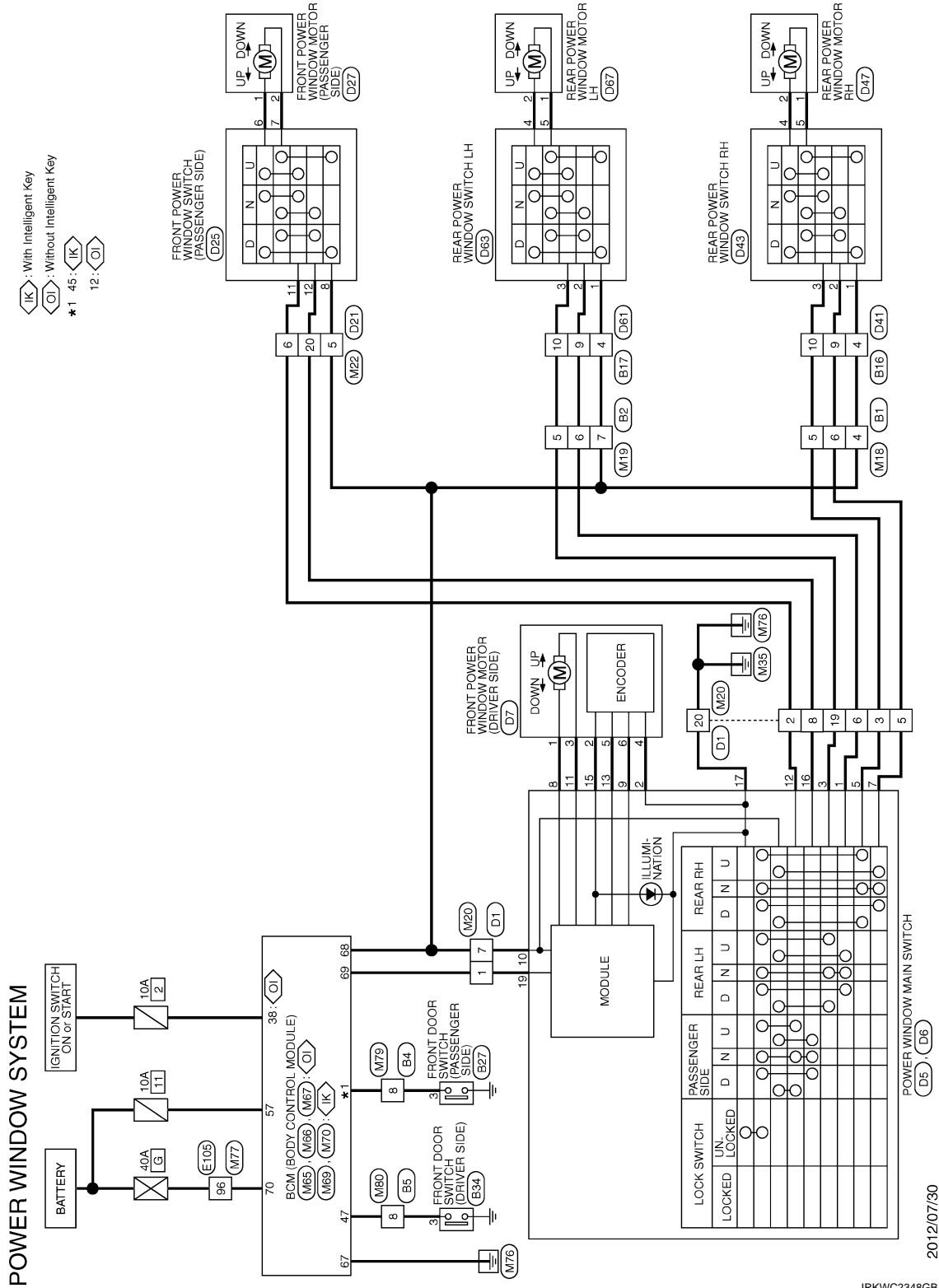

A  
B  
C  
D  
E  
F  
G  
H  
I  
J  
L  
M  
N  
O  
P

PWC

# POWER WINDOW MAIN SWITCH

< ECU DIAGNOSIS INFORMATION >

## POWER WINDOW SYSTEM

Connector No.	B1
Connector Name	WIRE TO WIRE
Connector Type	NS16MV-CS



Terminal No.	Color Of Wire	Signal Name [Specification]
1	G	-
3	V	-
4	L	-
5	Y	-
6	W	-
7	LG	-
10	W	-
11	G	-
12	V	-
13	BR	-
15	R	-
16	GR	-

Connector No.	B2
Connector Name	WIRE TO WIRE
Connector Type	NS16MV-CS



Terminal No.	Color Of Wire	Signal Name [Specification]
1	V	-
5	O	-
6	R	-
7	L	-
8	G	-
9	G	-
10	V	-

11	P	-
12	LG	-
14	R	-
15	Y	-
16	B	-

Connector No.	B4
Connector Name	WIRE TO WIRE
Connector Type	TH24MV-NH



Terminal No.	Color Of Wire	Signal Name [Specification]
1	W	-
2	V	-
3	O	-
4	P	-
5	W	-
8	SB	-
9	GR	-
10	SB	-
11	G	-
12	SB	-
13	L	-
15	R	-
16	GR	-
17	BR	-
18	L	-
20	LG	-
22	Y	-
23	BR	-
24	O	-

Connector No.	B5
Connector Name	WIRE TO WIRE
Connector Type	TH16MV-NH



Terminal No.	Color Of Wire	Signal Name [Specification]
1	V	-
2	GR	-
5	V	-
6	W	-
8	LG	-
9	R	-
11	O	-
13	GR	-
14	P	-
16	W	-

Connector No.	B16
Connector Name	WIRE TO WIRE
Connector Type	NS10FM-CS

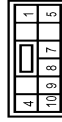

Terminal No.	Color Of Wire	Signal Name [Specification]
1	V	-
4	L	-
5	G	-
7	GR	-
8	LG	-
9	W	-
10	Y	-

Connector No.	B17
Connector Name	WIRE TO WIRE
Connector Type	NS10FM-CS

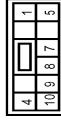

Terminal No.	Color Of Wire	Signal Name [Specification]
1	V	-
4	L	-
5	G	-
7	V	-
8	V	-
9	R	-
10	O	-

Connector No.	B27
Connector Name	FRONT DOOR SWITCH (PASSENGER SIDE)
Connector Type	TH04FW-NH



Terminal No.	Color Of Wire	Signal Name [Specification]
3	SB	-

JRKWC9361GB

# POWER WINDOW MAIN SWITCH

< ECU DIAGNOSIS INFORMATION >

## POWER WINDOW SYSTEM

Connector No.	B34
Connector Name	FRONT DOOR SWITCH (DRIVER SIDE)
Connector Type	TH04FW-NH



Terminal No.	Color Of Wire	Signal Name [Specification]
3	LG	-

Connector No.	D1
Connector Name	WIRE TO WIRE
Connector Type	NH10FW-CS10

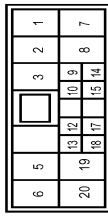

Terminal No.	Color Of Wire	Signal Name [Specification]
1	P	-
2	SB	-
3	Y	-
5	LG	-
6	R	-
7	L	-
8	W	-
9	BR	-
10	P	-
12	GR	-
13	W	-
14	G	-
15	V	-
17	R	-
18	L	-
19	O	-
20	B	-

Connector No.	D5
Connector Name	POWER WINDOW MAIN SWITCH
Connector Type	NS16FW-CS

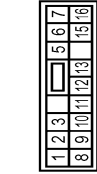

Terminal No.	Color Of Wire	Signal Name [Specification]
1	R	-
2	LG	-
3	O	-
5	V	-
6	V	-
7	LG	-
8	BR	-
9	V	-
10	L	-
11	GR	-
12	SB	-
13	W	-
15	G	-
16	W	-

Connector No.	D6
Connector Name	POWER WINDOW MAIN SWITCH
Connector Type	NS03FW-CS



Terminal No.	Color Of Wire	Signal Name [Specification]
17	B	-
18	GR	-
19	P	-

Connector No.	D7
Connector Name	FRONT POWER WINDOW MOTOR (DRIVER SIDE)
Connector Type	RS06FG



Terminal No.	Color Of Wire	Signal Name [Specification]
1	BR	-
2	G	-
3	GR	-
4	LG	-
5	W	-
6	V	-

Connector No.	D21
Connector Name	WIRE TO WIRE
Connector Type	NH10FW-CS10

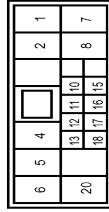

Terminal No.	Color Of Wire	Signal Name [Specification]
1	G	-
2	Y	-
4	B	-
5	L	-
6	SB	-
7	R	-
8	V	-
10	W	-
11	L	-
12	LG	-
13	P	-
15	G	-
16	GR	-
17	BR	-

18	V
20	W

Connector No.	D25
Connector Name	FRONT POWER WINDOW SWITCH (PASSENGER SIDE)
Connector Type	NS12FW-CS

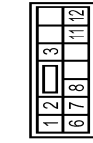

Terminal No.	Color Of Wire	Signal Name [Specification]
1	GR	-
2	BR	-
3	B	-
6	Y	-
7	R	-
8	L	-
11	SB	-
12	W	-

Connector No.	D27
Connector Name	FRONT POWER WINDOW MOTOR (PASSENGER SIDE)
Connector Type	RS06FG



Terminal No.	Color Of Wire	Signal Name [Specification]
1	Y	-
2	R	-

A  
B  
C  
D  
E  
F  
G  
H  
I  
J  
L  
M  
N  
O  
P

PWC

JRKWC9362GB

# POWER WINDOW MAIN SWITCH

< ECU DIAGNOSIS INFORMATION >

## POWER WINDOW SYSTEM

Connector No.	D41
Connector Name	WIRE TO WIRE
Connector Type	NS10MW-CS

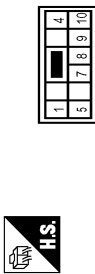

Terminal No.	Color Of Wire	Signal Name [Specification]
1	W	-
2	L	-
3	P	-
4	GR	-
5	LG	-
6	BR	-
7	O	-
8	O	-
9	O	-
10	O	-

Connector No.	D43
Connector Name	REAR POWER WINDOW SWITCH RH
Connector Type	NS08PW-CS

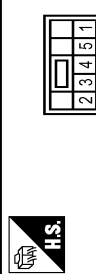

Terminal No.	Color Of Wire	Signal Name [Specification]
1	L	-
2	BR	-
3	O	-
4	G	-
5	R	-

Connector No.	D47
Connector Name	REAR POWER WINDOW MOTOR RH
Connector Type	RS08FG



Terminal No.	Color Of Wire	Signal Name [Specification]
1	R	-
2	G	-

Connector No.	D61
Connector Name	WIRE TO WIRE
Connector Type	NS10MW-CS

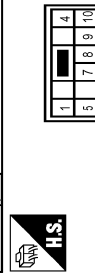

Terminal No.	Color Of Wire	Signal Name [Specification]
1	V	-
4	L	-
5	G	-
7	GR	-
8	LG	-
9	BR	-
10	O	-

Connector No.	D63
Connector Name	REAR POWER WINDOW SWITCH LH
Connector Type	NS08PW-CS



Terminal No.	Color Of Wire	Signal Name [Specification]
1	L	-
2	BR	-
3	O	-
4	G	-
5	R	-

Connector No.	D67
Connector Name	REAR POWER WINDOW MOTOR LH
Connector Type	RS08FG



Terminal No.	Color Of Wire	Signal Name [Specification]
1	R	-
2	G	-

Connector No.	E105
Connector Name	WIRE TO WIRE
Connector Type	TH80MW-CS16-TM4

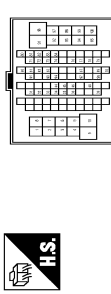

Terminal No.	Color Of Wire	Signal Name [Specification]
1	V	-
2	W	-
3	SB	-
4	G	-
5	P	-
6	L	- [With NAVI]
7	Y	- [Without NAVI]
8	O	-
9	W	-
10	SB	-
11	V	-
12	R	-
13	GR	-
14	P	-
15	Y	-
16	BR	-
17	SB	-
18	R	-
19	V	-
20	SB	-
21	V	-
22	R	-
23	GR	-
24	P	-
25	Y	-
26	BR	-
27	SB	-
28	R	-
29	V	-
30	SB	-
31	V	-
32	R	-
33	GR	-
34	P	-
35	Y	-
36	BR	-
37	SB	-
38	R	-
39	SB	-
40	R	-
41	V	-
42	V	-
43	P	-
44	R	-
45	V	-
46	P	-
47	L	-
48	L	-
49	B	- [With M/T]
50	B	- [With CVT]
51	BR	-
52	SB	-
53	SB	-
54	O	- [With M/T]
55	W	- [With CVT]
56	LG	-
57	L	-
58	O	-
59	O	-
60	O	-
61	G	-
62	W	-
63	L	-
64	L	-
65	GR	- [With CVT]
66	V	- [With M/T]
67	V	-
68	P	-

JRKWC9363GB



# POWER WINDOW MAIN SWITCH

< ECU DIAGNOSIS INFORMATION >

## POWER WINDOW SYSTEM

70	SHIELD	-	-
71	GR	-	-
72	LG	-	-
73	P	-	-
74	V	-	-
76	Y	-	-
77	LG	-	-
78	O	-	-
79	G	-	-
80	P	-	-
81	L	-	-
82	W	-	-
83	BR	-	-
84	B	-	-
91	W	-	-
92	Y	-	-
93	R	-	-
95	V	-	-
96	LG	-	-
97	R	-	-
98	SB	-	-
99	G	-	-
100	P	-	-

Connector No.	M18
Connector Name	WIRE TO WIRE
Connector Type	NS16FW-CS



7	6	5	4	3	1	
16	15	14	13	12	11	10

Terminal No.	Color Of Wire	Signal Name [Specification]
1	GR	-
3	L/W	-
4	L	-
5	Y	-
7	L/B	-
9	LG	-
10	W/L	-
11	G	-
12	V	-
13	L	-

15	L	R
16	GR	-

Connector No.	M19
Connector Name	WIRE TO WIRE
Connector Type	NS16FW-CS



7	6	5	1				
16	15	14	12	11	10	9	8

Terminal No.	Color Of Wire	Signal Name [Specification]
1	V	-
5	L/R	-
6	R	-
7	L	-
8	R/B	-
9	G	-
10	V	-
11	L/W	-
12	LG	-
14	R	-
15	Y/R	-
16	B/R	-

Connector No.	M20
Connector Name	WIRE TO WIRE
Connector Type	NH10MW-CS10



1	2	3	5	6			
7	8	9	10	12	13	19	20
14	15	17	18				

Terminal No.	Color Of Wire	Signal Name [Specification]
1	L/W	-
2	W/R	-
3	Y	-
5	L/B	-

6	R	-
7	L	-
8	Y/R	-
9	SB	-
10	LG	-
12	GR	-
13	W/B	-
14	G/B	-
15	V	-
17	BR	-
18	W/R	-
19	L/R	-
20	B	-

Connector No.	M22
Connector Name	WIRE TO WIRE
Connector Type	NH10MW-CS10



1	2	4	5	6		
7	8	10	11	12	13	20
15	16	17	18			

Terminal No.	Color Of Wire	Signal Name [Specification]
1	G	-
2	G	-
4	B	-
5	L	-
6	W/R	-
7	R	-
8	V	-
10	LG	-
11	R	-
12	G	-
13	B/Y	-
15	G/B	-
16	GR	-
17	BR	-
18	L/Y	-
20	Y/R	-

Connector No.	M65
Connector Name	BCM (BODY CONTROL MODULE)
Connector Type	TH40FV-NH



2	3	4	5	6	7	8	9	10	11	12	13	14	15	16	17	18	19	20
---	---	---	---	---	---	---	---	----	----	----	----	----	----	----	----	----	----	----

Terminal No.	Color Of Wire	Signal Name [Specification]
2	BR/W	COMBI SW IN/PLT 5
3	GR	COMBI SW IN/PLT 4
4	L/Y	COMBI SW IN/PLT 3
5	G	COMBI SW IN/PLT 2
6	L/R	COMBI SW IN/PLT 1
7	W/R	KEY CYL UNLOCK SW
8	W/B	KEY CYL LOCK SW
9	R	STOP LAMP SW
10	W/L	REAR WINDOW DEFROGGER SW
11	L/Y	ACC POWER SUPPLY
12	SB	PASSENGER DOOR SW
13	GR/L	REAR RH DOOR SW
18	V	RECEIVER / SENSOR GND
19	BR	KEYLESS ENTRY RECEIVER POWER SUPPLY
20	G/Y	KEYLESS ENTRY RECEIVER COMM
21	P/L	NATS ANTENNA AMP.
23	R/Y	SECURITY INDICATOR LAMP
25	LG	NATS ANTENNA AMP.
26	GR	THERMO CONTROL AMP.
27	Y/G	A/C SW
28	G/W	BLOWER FAN SW
29	L/W	HAZARD SW
31	G/Y	FR DEFROSTER SW
32	LG	COMBI SW OUTPUT 5
33	Y/L	COMBI SW OUTPUT 4
34	W	COMBI SW OUTPUT 3
35	R/L	COMBI SW OUTPUT 2
36	L/O	COMBI SW OUTPUT 1
37	R/W	KEY SWITCH
38	O	IGNITION POWER SUPPLY
39	L	CAN/H
40	P	CAN/L

A  
B  
C  
D  
E  
F  
G  
H  
I  
J  
L  
M  
N  
O  
P

PWC

# POWER WINDOW MAIN SWITCH

< ECU DIAGNOSIS INFORMATION >

## POWER WINDOW SYSTEM

Connector No.	M66
Connector Name	BCM (BODY CONTROL MODULE)
Connector Type	FEA09FW-FHAG-SA



Terminal No.	Color Of Wire	Signal Name [Specification]
43	W	BACK DOOR SW
44	LG	REAR WIPER STOP POSITION
45	GR	CENTRAL DOOR LOCK SW
46	BR	CENTRAL DOOR UNLOCK SW
47	BR/Y	DRIVER DOOR SW
48	W/G	REAR LH DOOR SW
50	BR	A/C INDICATOR OUTPUT
54	LG	REAR WIPER OUTPUT

Connector No.	M67
Connector Name	BCM (BODY CONTROL MODULE)
Connector Type	FEA09FB-FHAG-SA



Terminal No.	Color Of Wire	Signal Name [Specification]
56	L	INTERIOR ROOM LAMP POWER SUPPLY
57	Y	INTERIOR ROOM LAMP POWER SUPPLY BAT (FUSE)
59	L/B	DRIVER DOOR UNLOCK OUTPUT
60	W/B	TURN SIGNAL LH OUTPUT
61	W/L	TURN SIGNAL RH OUTPUT
63	BR	ROOM LAMP TIMER CONTROL
65	V	ALL DOOR LOCK OUTPUT
66	G	PASSENGER DOOR LOCK UNLOCK OUTPUT
67	B	GROUND
68	L	POWER WINDOW POWER SUPPLY (GS)
69	P	POWER WINDOW POWER SUPPLY (BAT)
70	Y	BAT (FL)

Connector No.	M69
Connector Name	BCM (BODY CONTROL MODULE)
Connector Type	FEA09FB-FHAG-SA



Terminal No.	Color Of Wire	Signal Name [Specification]
43	W	BACK DOOR SW
44	LG	REAR WIPER STOP POSITION
45	SB	PASSENGER DOOR SW
46	GR/L	REAR RH DOOR SW
47	BR/Y	DRIVER DOOR SW
48	W/G	REAR LH DOOR SW
50	BR	BK DR LOCK AGT RELAY CONT
51	W	BACK DOOR REQUEST SW
54	LG	REAR WIPER OUTPUT
55	G	REAR DOOR UNLOCK OUTPUT

Connector No.	M70
Connector Name	BCM (BODY CONTROL MODULE)
Connector Type	FEA09FW-FHAG-SA



Terminal No.	Color Of Wire	Signal Name [Specification]
56	L	INTERIOR ROOM LAMP POWER SUPPLY
57	Y	INTERIOR ROOM LAMP POWER SUPPLY BAT (FUSE)
59	G	PASSENGER DOOR UNLOCK OUTPUT
60	W/B	TURN SIGNAL LH OUTPUT
61	W/L	TURN SIGNAL RH OUTPUT
63	BR	ROOM LAMP TIMER CONTROL
65	V	ALL DOOR LOCK OUTPUT
66	L/B	DRIVER DOOR UNLOCK OUTPUT
67	B	GROUND
68	L	POWER WINDOW POWER SUPPLY (GS)

69	P	POWER WINDOW POWER SUPPLY (BAT)
70	Y	BAT (FL)

Connector No.	M77
Connector Name	WIRE TO WIRE
Connector Type	TH80FW-CS16-TM4



Terminal No.	Color Of Wire	Signal Name [Specification]
1	R/O	-
2	BR	-
3	GR	-
4	G/B	-
5	L	-
6	L	-
7	W/R	-
8	GW	-
9	Y/L	-
10	W	-
31	GR/L	-
32	L/B	-
33	R/Y	-
34	SB	-
35	BR	-
36	G	-
39	L/R	-
44	G/O	-
45	LG/R	-
46	GR/W	-
48	L/O	-
51	B/W	-
54	O	-
57	GR	-
59	V	-
60	R/W	-
61	P/W	-
62	W/L	-
63	W/B	-
67	YR	-
69	LG	-

Connector No.	M79
Connector Name	WIRE TO WIRE
Connector Type	TH24FW-NH

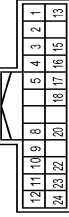

Terminal No.	Color Of Wire	Signal Name [Specification]
1	W/G	-
2	L/Y	-
3	R	-
4	P/B	-
5	W	-
8	SB	-
9	L/G	-
10	GR/B	-
11	G/B	-
12	GR	-

# POWER WINDOW MAIN SWITCH

< ECU DIAGNOSIS INFORMATION >

A  
B  
C  
D  
E  
F  
G  
H  
I  
J  
L  
M  
N  
O  
P

PWC

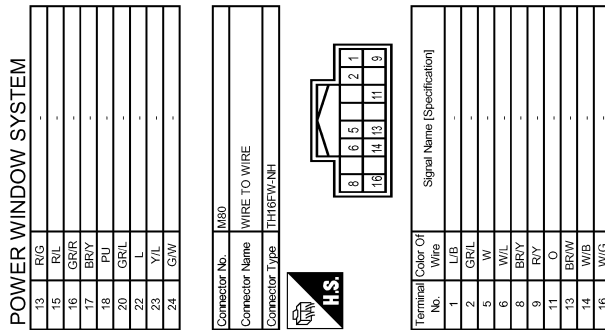

## Fail Safe

### FAIL-SAFE CONTROL

Switches to fail-safe control when malfunction is detected in encoder signal that detects up/down speed and direction of door glass. Switches to fail-safe control when error beyond regulation value is detected between the fully closed position and the actual position of the glass.

JRKWC9366GB

INFOID:000000009950895

# POWER WINDOW MAIN SWITCH

## < ECU DIAGNOSIS INFORMATION >

Error	Error condition
Pulse sensor malfunction	When only one side of pulse signal is being detected for more than the specified value.
Both pulse sensors malfunction	When both pulse signals have not been detected for more than the specified value during glass open/close operation.
Pulse direction malfunction	When the pulse signal that is detected during glass open/close operation detects the opposite condition of power window motor operating direction.
Glass recognition position malfunction 1	When it detects the error between glass fully closed position in power window switch memory and actual fully closed position during glass open/close operation is more than the specified value.
Glass recognition position malfunction 2	When it detects pulse count more than the value of glass full stroke during glass open/close operation.
Malfunction of not yet updated closed position of glass	When glass open/close operation is continuously performed without fully closing more than the specified value (approximately 10 strokes).

It changes to condition before initialization and the following functions do not operate when switched to fail-safe control.

- Auto-up operation
- Anti-pinch function

Perform initial operation to recover when switched to fail-safe mode. However, it switches back to fail-safe control when malfunction is found in power window main switch or front power window motor (driver side).

# NONE OF THE POWER WINDOWS CAN BE OPERATED USING ANY SWITCH

< SYMPTOM DIAGNOSIS >

## SYMPTOM DIAGNOSIS

NONE OF THE POWER WINDOWS CAN BE OPERATED USING ANY SWITCH

### Diagnosis Procedure

INFOID:000000009950896

#### 1. CHECK BCM POWER SUPPLY AND GROUND CIRCUIT

Check BCM power supply and ground circuit. Refer to the following.

- With Intelligent Key: Refer to [BCS-44, "Diagnosis Procedure"](#).
- Without Intelligent Key: Refer to [BCS-123, "Diagnosis Procedure"](#).

Is the inspection result normal?

YES >> GO TO 2.

NO >> Repair or replace the malfunctioning parts.

#### 2. CONFIRM THE OPERATION

Confirm the operation again.

Is the result normal?

YES >> Check intermittent incident. Refer to [GI-40, "Intermittent Incident"](#).

NO >> GO TO 1.

A  
B  
C  
D  
E  
F  
G  
H  
I  
J  
L  
M  
N  
O  
P

PWC

# DRIVER SIDE POWER WINDOW DOES NOT OPERATE

< SYMPTOM DIAGNOSIS >

---

## DRIVER SIDE POWER WINDOW DOES NOT OPERATE

### Diagnosis Procedure

INFOID:000000009950897

#### 1. CHECK POWER WINDOW MAIN SWITCH POWER SUPPLY AND GROUND CIRCUIT

---

Check power window main switch power supply and ground circuit

Refer to [PWC-16, "POWER WINDOW MAIN SWITCH : Diagnosis Procedure"](#).

Is the inspection result normal?

YES >> GO TO 2.

NO >> Repair or replace the malfunctioning parts.

#### 2. CHECK FRONT POWER WINDOW MOTOR (DRIVER SIDE)

---

Check power window motor.

Refer to [PWC-23, "DRIVER SIDE : Component Function Check"](#).

Is the inspection result normal?

YES >> GO TO 3.

NO >> Repair or replace the malfunctioning parts.

#### 3. CONFIRM THE OPERATION

---

Confirm the operation again.

Is the result normal?

YES >> Check intermittent incident. Refer to [GI-40, "Intermittent Incident"](#).

NO >> GO TO 1.

# FRONT PASSENGER SIDE POWER WINDOW DOES NOT OPERATE

< SYMPTOM DIAGNOSIS >

## FRONT PASSENGER SIDE POWER WINDOW DOES NOT OPERATE WITH BOTH POWER WINDOW MAIN SWITCH AND FRONT PASSENGER SIDE POWER WINDOW SWITCH

WITH BOTH POWER WINDOW MAIN SWITCH AND FRONT PASSENGER SIDE  
POWER WINDOW SWITCH : Diagnosis Procedure

INFOID:000000009950898

### 1. CHECK FRONT POWER WINDOW SWITCH (PASSENGER SIDE)

Check front power window switch (passenger side).  
Refer to [PWC-19, "Component Function Check"](#).

Is the inspection result normal?

YES >> GO TO 2.

NO >> Repair or replace the malfunctioning parts

### 2. CHECK FRONT POWER WINDOW MOTOR (PASSENGER SIDE)

Check front power window motor (passenger side).  
Refer to [PWC-24, "PASSENGER SIDE : Component Function Check"](#).

Is the inspection result normal?

YES >> GO TO 3.

NO >> Repair or replace the malfunctioning parts.

### 3. CONFIRM THE OPERATION

Confirm the operation again.

Is the result normal?

YES >> Check intermittent incident. Refer to [GI-40, "Intermittent Incident"](#).

NO >> GO TO 1.

## WITH FRONT POWER WINDOW SWITCH ONLY

WITH FRONT POWER WINDOW SWITCH ONLY : Diagnosis Procedure

INFOID:000000009950899

### 1. CHECK FRONT POWER WINDOW SWITCH (PASSENGER SIDE) POWER SUPPLY AND GROUND CIRCUIT

Check front power window switch (passenger side) power supply and ground circuit.  
Refer to [PWC-17, "FRONT POWER WINDOW SWITCH \(PASSENGER SIDE\) : Diagnosis Procedure"](#).

Is the inspection result normal?

YES >> GO TO 2.

NO >> Repair or replace the malfunctioning parts.

### 2. CHECK FRONT POWER WINDOW SWITCH (PASSENGER SIDE)

Check front power window switch (passenger side).  
Refer to [PWC-19, "Component Function Check"](#).

Is the inspection result normal?

YES >> GO TO 3.

NO >> Repair or replace the malfunctioning parts

### 3. CONFIRM THE OPERATION

Confirm the operation again.

Is the result normal?

YES >> Check intermittent incident. Refer to [GI-40, "Intermittent Incident"](#).

NO >> GO TO 1.

A  
B  
C  
D  
E  
F  
G  
H  
I  
J  
L  
M  
N  
O  
P

PWC

## REAR LH SIDE POWER WINDOW DOES NOT OPERATE

< SYMPTOM DIAGNOSIS >

---

### REAR LH SIDE POWER WINDOW DOES NOT OPERATE WITH BOTH POWER WINDOW MAIN SWITCH AND REAR POWER WINDOW SWITCH LH

WITH BOTH POWER WINDOW MAIN SWITCH AND REAR POWER WINDOW  
SWITCH LH : Diagnosis Procedure

INFOID:000000009950901

#### 1.CHECK REAR POWER WINDOW SWITCH

Check rear power window switch.

Refer to [PWC-21, "Component Function Check"](#).

Is the inspection result normal?

YES >> GO TO 2.

NO >> Repair or replace the malfunctioning parts.

#### 2.CHECK REAR POWER WINDOW MOTOR LH

Check rear power window motor LH.

Refer to [PWC-25, "REAR LH : Component Function Check"](#).

Is the inspection result normal?

YES >> GO TO 3.

NO >> Repair or replace the malfunctioning parts.

#### 3.CONFIRM THE OPERATION

Confirm the operation again.

Is the result normal?

YES >> Check intermittent incident. Refer to [GI-40, "Intermittent Incident"](#).

NO >> GO TO 1.

### WITH REAR POWER WINDOW SWITCH LH ONLY

WITH REAR POWER WINDOW SWITCH LH ONLY : Diagnosis Procedure

INFOID:000000009950901

#### 1.CHECK REAR POWER WINDOW SWITCH POWER SUPPLY AND GROUND CIRCUIT

Check rear power window switch power supply and ground circuit.

Refer to [PWC-17, "REAR POWER WINDOW SWITCH : Diagnosis Procedure"](#).

Is the inspection result normal?

YES >> GO TO 2.

NO >> Repair or replace the malfunctioning parts.

#### 2.CHECK REAR POWER WINDOW SWITCH

Check rear power window switch.

Refer to [PWC-21, "Component Function Check"](#).

Is the inspection result normal?

YES >> GO TO 3.

NO >> Repair or replace the malfunctioning parts.

#### 3.CONFIRM THE OPERATION

Confirm the operation again.

Is the result normal?

YES >> Check intermittent incident. Refer to [GI-40, "Intermittent Incident"](#).

NO >> GO TO 1.



# REAR RH SIDE POWER WINDOW DOES NOT OPERATE

< SYMPTOM DIAGNOSIS >

REAR RH SIDE POWER WINDOW DOES NOT OPERATE  
WITH BOTH POWER WINDOW MAIN SWITCH AND REAR POWER WINDOW SWITCH RH

WITH BOTH POWER WINDOW MAIN SWITCH AND REAR POWER WINDOW SWITCH RH : Diagnosis Procedure

INFOID:000000009950902

## 1.CHECK REAR POWER WINDOW SWITCH

Check rear power window switch.  
Refer to [PWC-21, "Component Function Check"](#).

Is the inspection result normal?

- YES >> GO TO 2.
- NO >> Repair or replace the malfunctioning parts.

## 2.CHECK REAR POWER WINDOW MOTOR RH

Check rear power window motor RH.  
Refer to [PWC-26, "REAR RH : Component Function Check"](#).

Is the inspection result normal?

- YES >> GO TO 3.
- NO >> Repair or replace the malfunctioning parts.

## 3.CONFIRM THE OPERATION

Confirm the operation again.

Is the result normal?

- YES >> Check intermittent incident. Refer to [GI-40, "Intermittent Incident"](#).
- NO >> GO TO 1.

WITH REAR POWER WINDOW SWITCH RH ONLY

WITH REAR POWER WINDOW SWITCH RH ONLY : Diagnosis Procedure

INFOID:000000009950903

## 1.CHECK REAR POWER WINDOW SWITCH POWER SUPPLY AND GROUND CIRCUIT

Check rear power window switch power supply and ground circuit.  
Refer to [PWC-17, "REAR POWER WINDOW SWITCH : Diagnosis Procedure"](#).

Is the inspection result normal?

- YES >> GO TO 2.
- NO >> Repair or replace the malfunctioning parts.

## 2.CHECK REAR POWER WINDOW SWITCH

Check rear power window switch.  
Refer to [PWC-21, "Component Function Check"](#).

Is the inspection result normal?

- YES >> GO TO 3.
- NO >> Repair or replace the malfunctioning parts.

## 3.CONFIRM THE OPERATION

Confirm the operation again.

Is the result normal?

- YES >> Check intermittent incident. Refer to [GI-40, "Intermittent Incident"](#).
- NO >> GO TO 1.

A  
B  
C  
D  
E  
F  
G  
H  
I  
J  
L  
M  
N  
O  
P

PWC

## ANTI-PINCH SYSTEM DOES NOT OPERATE NORMALLY (DRIVER SIDE)

< SYMPTOM DIAGNOSIS >

### ANTI-PINCH SYSTEM DOES NOT OPERATE NORMALLY (DRIVER SIDE)

---

#### Diagnosis Procedure

INFOID:000000009950904

#### 1. CHECK POWER WINDOW AUTO OPERATION

---

Check AUTO operation when anti-pinch function does not operate.

Is the inspection result normal?

YES >> GO TO 2.

NO >> Refer to [PWC-108, "Diagnosis Procedure"](#).

#### 2. CONFIRM THE OPERATION

---

Confirm the operation again.

Is the result normal?

YES >> Check intermittent incident. Refer to [GI-40, "Intermittent Incident"](#).

NO >> GO TO 1.

# POWER WINDOW RETAINED POWER OPERATION DOES NOT OPERATE PROPERLY

< SYMPTOM DIAGNOSIS >

## POWER WINDOW RETAINED POWER OPERATION DOES NOT OPERATE PROPERLY

### Diagnosis Procedure

INFOID:000000009950905

#### 1. CHECK FRONT DOOR SWITCH

Check front door switch. Refer to the following.

- With Intelligent Key: Refer to [DLK-55, "Component Function Check"](#).
- Without Intelligent Key: Refer to [DLK-249, "Component Function Check"](#).

Is the inspection result normal?

YES >> GO TO 2.

NO >> Repair or replace the malfunctioning parts.

#### 2. CONFIRM THE OPERATION

Confirm the operation again.

Is the result normal?

YES >> Check intermittent incident. Refer to [GI-40, "Intermittent Incident"](#).

NO >> GO TO 1.

A  
B  
C  
D  
E  
F  
G  
H  
I  
J  
L  
M  
N  
O  
P

PWC

# AUTO OPERATION DOES NOT OPERATE BUT MANUAL OPERATE NORMALLY (DRIVER SIDE)

< SYMPTOM DIAGNOSIS >

## AUTO OPERATION DOES NOT OPERATE BUT MANUAL OPERATE NORMALLY (DRIVER SIDE)

### Diagnosis Procedure

INFOID:000000009950906

#### 1.PERFORM INITIALIZATION PROCEDURE

Initialization procedure is executed and operation is confirmed.

Refer to [PWC-5, "ADDITIONAL SERVICE WHEN REMOVING BATTERY NEGATIVE TERMINAL : Special Repair Requirement"](#).

Is the inspection result normal?

YES >> INSPECTION END  
NO >> GO TO 2.

#### 2.CHECK ENCODER

Check encoder.

Refer to [PWC-28, "Component Function Check"](#).

Is the inspection result normal?

YES >> GO TO 3.  
NO >> Repair or replace the malfunctioning parts.

#### 3.REPLACE POWER WINDOW MAIN SWITCH

Replace power window main switch.

Refer to [PWC-112, "Removal and Installation"](#).

Is the inspection result normal?

YES >> INSPECTION END  
NO >> GO TO 4.

#### 4.CONFIRM THE OPERATION

Confirm the operation again.

Is the result normal?

YES >> Check intermittent incident. Refer to [GI-40, "Intermittent Incident"](#).  
NO >> GO TO 1.

# POWER WINDOW LOCK SWITCH DOES NOT FUNCTION

< SYMPTOM DIAGNOSIS >

---

## POWER WINDOW LOCK SWITCH DOES NOT FUNCTION

Diagnosis Procedure

INFOID:000000009950907

### 1. REPLACE POWER WINDOW MAIN SWITCH

---

Replace power window main switch.

>> Refer to [PWC-112. "Removal and Installation"](#).

A  
B  
C  
D  
E  
F  
G  
H  
I  
J  
L  
M  
N  
O  
P

PWC

# PRECAUTIONS

< PRECAUTION >

## PRECAUTION

### PRECAUTIONS

#### Precaution for Supplemental Restraint System (SRS) "AIR BAG" and "SEAT BELT PRE-TENSIONER"

INFOID:000000010229559

The Supplemental Restraint System such as "AIR BAG" and "SEAT BELT PRE-TENSIONER", used along with a front seat belt, helps to reduce the risk or severity of injury to the driver and front passenger for certain types of collision. This system includes seat belt switch inputs and dual stage front air bag modules. The SRS system uses the seat belt switches to determine the front air bag deployment, and may only deploy one front air bag, depending on the severity of a collision and whether the front occupants are belted or unbelted. Information necessary to service the system safely is included in the "SRS AIR BAG" and "SEAT BELT" of this Service Manual.

#### **WARNING:**

Always observe the following items for preventing accidental activation.

- To avoid rendering the SRS inoperative, which could increase the risk of personal injury or death in the event of a collision that would result in air bag inflation, all maintenance must be performed by an authorized NISSAN/INFINITI dealer.
- Improper maintenance, including incorrect removal and installation of the SRS, can lead to personal injury caused by unintentional activation of the system. For removal of Spiral Cable and Air Bag Module, see "SRS AIR BAG".
- Never use electrical test equipment on any circuit related to the SRS unless instructed to in this Service Manual. SRS wiring harnesses can be identified by yellow and/or orange harnesses or harness connectors.

#### PRECAUTIONS WHEN USING POWER TOOLS (AIR OR ELECTRIC) AND HAMMERS

#### **WARNING:**

Always observe the following items for preventing accidental activation.

- When working near the Air Bag Diagnosis Sensor Unit or other Air Bag System sensors with the ignition ON or engine running, never use air or electric power tools or strike near the sensor(s) with a hammer. Heavy vibration could activate the sensor(s) and deploy the air bag(s), possibly causing serious injury.
- When using air or electric power tools or hammers, always switch the ignition OFF, disconnect the battery, and wait at least 3 minutes before performing any service.

#### Precautions for Removing of Battery Terminal

INFOID:000000010229627

- When removing the 12V battery terminal, turn OFF the ignition switch and wait at least 30 seconds.

#### **NOTE:**

ECU may be active for several tens of seconds after the ignition switch is turned OFF. If the battery terminal is removed before ECU stops, then a DTC detection error or ECU data corruption may occur.

- For vehicles with the 2-batteries, be sure to connect the main battery and the sub battery before turning ON the ignition switch.

#### **NOTE:**

If the ignition switch is turned ON with any one of the terminals of main battery and sub battery disconnected, then DTC may be detected.

- After installing the 12V battery, always check "Self Diagnosis Result" of all ECUs and erase DTC.

#### **NOTE:**

The removal of 12V battery may cause a DTC detection error.

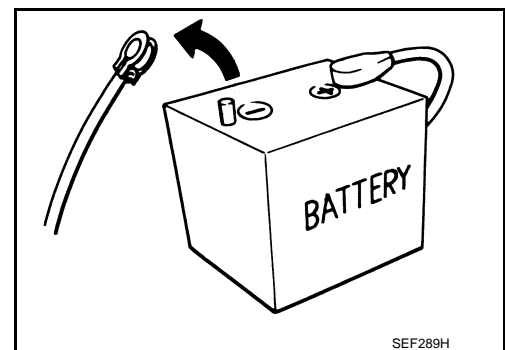

# PREPARATION

< PREPARATION >

## PREPARATION

### PREPARATION

#### Commercial Service Tools

INFOID:000000009950909

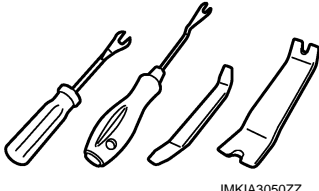
Tool name	Description
Remover tool  JMKIA3050ZZ	Removes the clips, pawls and metal clips

A  
B  
C  
D  
E  
F  
G  
H  
I  
J  
L  
M  
N  
O  
P

PWC

# POWER WINDOW MAIN SWITCH

< REMOVAL AND INSTALLATION >

## REMOVAL AND INSTALLATION

### POWER WINDOW MAIN SWITCH

#### Removal and Installation

INFOID:000000009950910

#### REMOVAL

1. Remove the power window main switch finisher (2). Refer to [INT-12. "Removal and Installation"](#).
2. Power window main switch (1) is removed from power window main switch finisher (2) using remover tool (A) etc.

 : Pawl

#### CAUTION:

**Never fold the pawl of power window main switch finisher.**

#### NOTE:

The same procedure is also performed for front power window switch (passenger side) and rear power window switch (LH & RH).

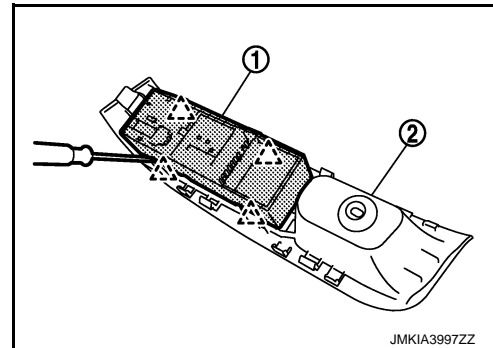

#### INSTALLATION

Install in the reverse order of removal.

#### NOTE:

Power window main switch is exchanged or is detached it is necessary to do the initialization procedure.

Refer to [PWC-5. "ADDITIONAL SERVICE WHEN REMOVING BATTERY NEGATIVE TERMINAL : Special Repair Requirement"](#).