

SECTION **RSU**
 REAR SUSPENSION

A
 B
 C
 D
 E
 F
 G
 H
 I
 J
 K
 L
 M
 N
 O
 P

RSU

CONTENTS

SYMPTOM DIAGNOSIS	2	REMOVAL AND INSTALLATION	7	F
NOISE, VIBRATION AND HARSHNESS (NVH) TROUBLESHOOTING	2	REAR SHOCK ABSORBER	7	G
NVH Troubleshooting Chart	2	Exploded View	7	
PRECAUTION	3	Removal and Installation	7	
PRECAUTIONS	3	Inspection	8	H
Precautions for Suspension	3	Disposal	8	
Precautions for Removing of Battery Terminal	3	COIL SPRING	9	I
PREPARATION	4	Exploded View	9	
PREPARATION	4	Removal and Installation	9	J
Commercial Service Tool	4	Inspection	9	
PERIODIC MAINTENANCE	5	REAR SUSPENSION BEAM	11	K
REAR SUSPENSION ASSEMBLY	5	Exploded View	11	
Inspection	5	Removal and Installation	11	L
WHEEL ALIGNMENT	6	Inspection	12	
Inspection	6	SERVICE DATA AND SPECIFICATIONS (SDS)	13	M
		SERVICE DATA AND SPECIFICATIONS (SDS)	13	N
		Wheel Alignment	13	O
		Wheelarch Height	13	P

NOISE, VIBRATION AND HARSHNESS (NVH) TROUBLESHOOTING

< SYMPTOM DIAGNOSIS >

SYMPTOM DIAGNOSIS

NOISE, VIBRATION AND HARSHNESS (NVH) TROUBLESHOOTING

NVH Troubleshooting Chart

INFOID:000000009948838

Use chart below to find the cause of the symptom. If necessary, repair or replace these parts.

Reference		RSU-7, RSU-9, RSU-11	RSU-7	—	—	—	RSU-7, RSU-9, RSU-11	RSU-6	NVH in RAX and RSU sections	NVH in WT section	NVH in WT section	NVH in BR section	
Possible cause and SUSPECTED PARTS		Improper installation, looseness	Shock absorber deformation, damage or deflection	Bushing or mounting deterioration	Parts interference	Spring fatigue	Suspension looseness	Incorrect wheel alignment	REAR AXLE AND REAR SUSPENSION	TIRE	ROAD WHEEL	BRAKE	
Symptom	REAR SUSPENSION	Noise	x	x	x	x	x		x	x	x	x	
		Shake	x	x	x	x		x	x	x	x	x	
		Vibration	x	x	x	x	x			x	x		
		Shimmy	x	x	x	x			x	x	x	x	x
		Judder	x	x	x					x	x	x	x
		Poor quality ride or handling	x	x	x	x	x		x	x	x	x	

x: Applicable

PRECAUTIONS

< PRECAUTION >

PRECAUTION

PRECAUTIONS

Precautions for Suspension

INFOID:000000009948839

- When installing rubber bushings, the final tightening must be carried out under unladen conditions with tires on ground. Spilled oil might shorten the life of rubber bushings. Be sure to wipe off any spilled oil.
- Unladen conditions mean that fuel, engine coolant and lubricant are full. Spare tire, jack, hand tools and mats are in designated positions.
- After servicing suspension parts, be sure to check wheel alignment.
- Self-lock nuts are not reusable. Always use new ones when installing. Since new self-lock nuts are pre-oiled, tighten as they are.

Precautions for Removing of Battery Terminal

INFOID:000000010085533

- When removing the 12V battery terminal, turn OFF the ignition switch and wait at least 30 seconds.

NOTE:

ECU may be active for several tens of seconds after the ignition switch is turned OFF. If the battery terminal is removed before ECU stops, then a DTC detection error or ECU data corruption may occur.

- For vehicles with the 2-batteries, be sure to connect the main battery and the sub battery before turning ON the ignition switch.

NOTE:

If the ignition switch is turned ON with any one of the terminals of main battery and sub battery disconnected, then DTC may be detected.

- After installing the 12V battery, always check "Self Diagnosis Result" of all ECUs and erase DTC.

NOTE:

The removal of 12V battery may cause a DTC detection error.

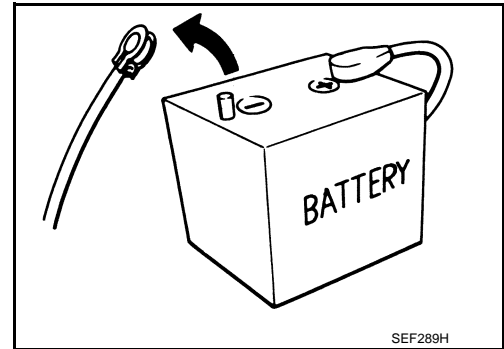

A
B
C
D
RSU
F
G
H
I
J
K
L
M
N
O
P

PREPARATION

< PREPARATION >

PREPARATION

PREPARATION

Commercial Service Tool

INFOID:000000009948840

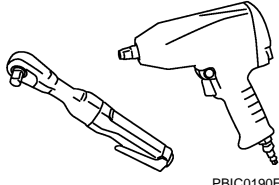
Tool name	Description
Power tool  PBIC0190E	Loosening bolts and nuts

REAR SUSPENSION ASSEMBLY

< PERIODIC MAINTENANCE >

PERIODIC MAINTENANCE

REAR SUSPENSION ASSEMBLY

Inspection

INFOID:000000009948841

COMPONENT PART

Check the mounting conditions (looseness, backlash) of each component and component conditions (wear, damage) are normal.

SHOCK ABSORBER ASSEMBLY

Check for oil leakage, damage, and replace if necessary.

A

B

C

D

RSU

F

G

H

I

J

K

L

M

N

O

P

WHEEL ALIGNMENT

< PERIODIC MAINTENANCE >

WHEEL ALIGNMENT

Inspection

INFOID:000000009948842

DESCRIPTION

- Camber, toe-in inclination angles cannot be adjusted.
- If camber, toe-in inclination angle is outside the standard, check front suspension parts for wear and damage. Replace suspect parts if a malfunction is detected.
- Measure wheel alignment under unladen conditions.

NOTE:

“Unladen conditions” means that fuel, engine coolant, and lubricant are full. Spare tire, jack, hand tools and mats are in designated positions.

PRELIMINARY CHECK

Check the following:

- Tires for improper air pressure and wear. Refer to [WT-54, "Tire Air Pressure"](#).
- Road wheels for runout.
- Wheel bearing axial end play. Refer to [RAX-5, "Inspection"](#).
- Shock absorber operation.
- Each mounting point of axle and suspension for looseness and deformation.
- Each of rear suspension beam and shock absorber for cracks, deformation, and other damage.
- Vehicle height (posture).

GENERAL INFORMATION AND RECOMMENDATIONS

- A four-wheel thrust alignment should be performed.
- This type of alignment is recommended for any NISSAN/INFINITI vehicle.
- The four-wheel “thrust” process helps ensure that the vehicle is properly aligned and the steering wheel is centered.
- The alignment rack itself should be capable of accepting any NISSAN/INFINITI vehicle.
- The rack should be checked to ensure that it is level.
- Check the machine is properly calibrated.
- Your alignment equipment should be regularly calibrated in order to give correct information.
- Check with the manufacturer of your specific equipment for their recommended Service/Calibration Schedule.

ALIGNMENT PROCESS

IMPORTANT:

Use only the alignment specifications listed in this Service Manual.

- When displaying the alignment settings, many alignment machines use “indicators”: (Green/red, plus or minus, Go/No Go). **Never use these indicators.**
- The alignment specifications programmed into your machine that operate these indicators may not be correct.
- This may result in an ERROR.
- Most camera-type alignment machines are equipped with both “Rolling Compensation” method and optional “Jacking Compensation” method to “compensate” the alignment targets or head units. “Rolling Compensation” is the preferred method.
- If using the “Rolling Compensation” method, after installing the alignment targets or head units, push or pull on the rear wheel to move the vehicle. **Do not push or pull on the vehicle body.**
- If using the “Jacking Compensation” method, after installing the alignment targets or head units, raise the vehicle and rotate the wheels 1/2 turn both ways.

NOTE:

- Do not use the “Rolling Compensation” method if you are using sensor-type alignment equipment.
- Follow all instructions for the alignment machine you're using for more information.

REAR SHOCK ABSORBER

< REMOVAL AND INSTALLATION >

REMOVAL AND INSTALLATION

REAR SHOCK ABSORBER

Exploded View

INFOID:000000009948843

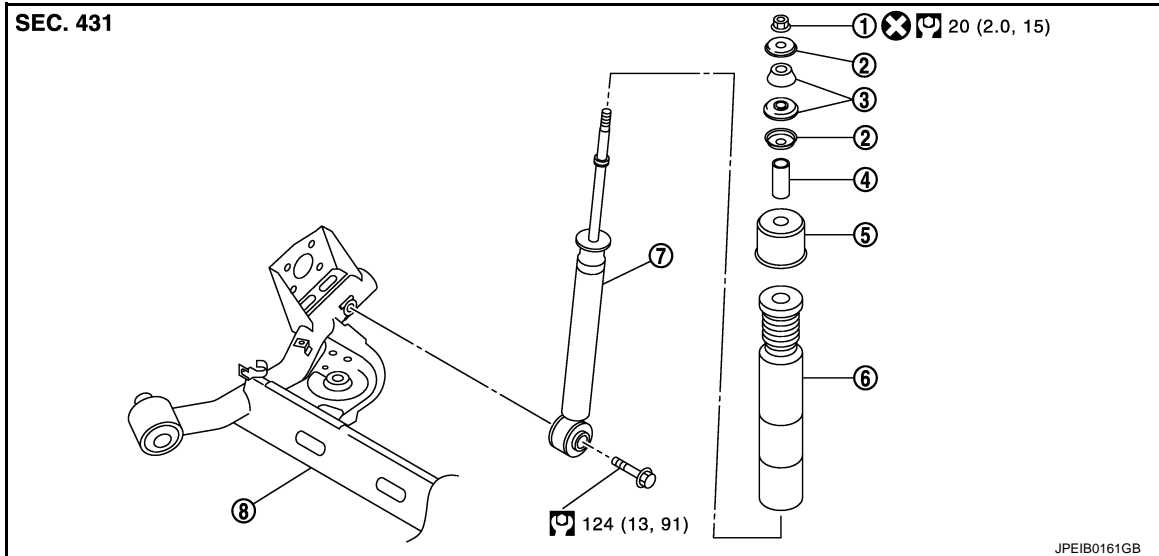

- | | | |
|------------------------|-------------------------|-----------------|
| 1. Piston rod lock nut | 2. Washer | 3. Bushing |
| 4. Distance tube | 5. Bound bumper cover | 6. Bound bumper |
| 7. Shock absorber | 8. Rear suspension beam | |

Refer to [GI-4, "Components"](#) for symbols in the figure.

Removal and Installation

INFOID:000000009948844

REMOVAL

1. Remove tires with power tool. Refer to [WT-46, "Exploded View"](#).
2. Set suitable jack under rear suspension beam.
CAUTION:
Check the stable condition when using a jack.
3. Remove shock absorber mounting bolt (lower side) with power tool.
4. Remove luggage lid from luggage side finisher. Refer to [INT-24, "Exploded View"](#).
5. Remove shock absorber mounting nut (upper side), and then remove washer and bushing.
6. Remove shock absorber assembly.

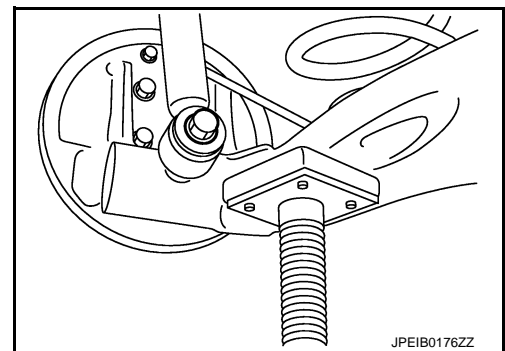

INSTALLATION

Note the following, and install in the reverse order of removal.

- Perform final tightening of bolts and nuts at the shock absorber lower side (rubber bushing), under unladen conditions with tires on level ground.

REAR SHOCK ABSORBER

< REMOVAL AND INSTALLATION >

- Install projection surely into the hole on the vehicle side as shown in the figure, when installing bushing.
- Hold a head of shock absorber piston rod nut to have it rotate, then tighten piston rod lock nut with a standard tightening torque value.

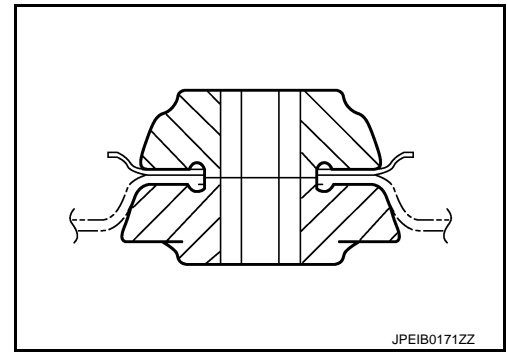

INFOID:000000009948845

Inspection

INSPECTION AFTER REMOVAL

Shock Absorber

Check the following items, and replace the part if necessary.

- Shock absorber for deformation, cracks, and other damage.
- Piston rod for damage, uneven wear, and distortion.

Bound Bumper, Bushing

Check for cracks and damage. Replace it if necessary.

Washer, Bound Bumper Cover, Distance Tube

- Check for cracks and damage. Replace it if necessary.

INSPECTION AFTER INSTALLATION

1. Check wheel alignment. Refer to [RSU-6, "Inspection"](#).
2. Adjust neutral position of steering angle sensor. Refer to [BRC-9, "Special Repair Requirement"](#).

Disposal

INFOID:000000009948846

1. Set shock absorber horizontally to the ground with the piston rod fully extracted.
2. Drill 2 – 3 mm (0.08 – 0.12 in) hole at the position (●) from top as shown in the figure to release gas gradually.

CAUTION:

- Wear eye protection (safety glasses).
- Wear gloves.
- Be careful with metal chips or oil blown out by the compressed gas.

NOTE:

- Drill vertically in this direction (←).
- Directly to the outer tube avoiding brackets.
- The gas is clear, colorless, odorless, and harmless.

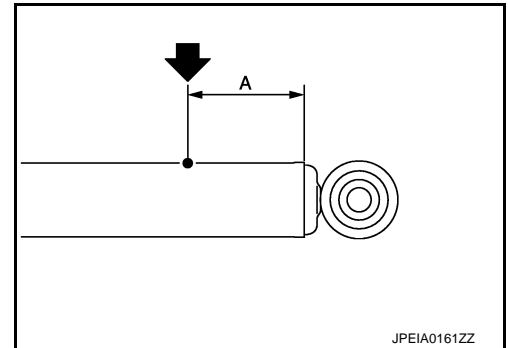

A : 20 – 30 mm (0.79 – 1.18 in)

3. Position the drilled hole downward and drain oil by moving the piston rod several times.

CAUTION:

Dispose of drained oil according to the law and local regulations.

COIL SPRING

< REMOVAL AND INSTALLATION >

COIL SPRING

Exploded View

INFOID:000000009948847

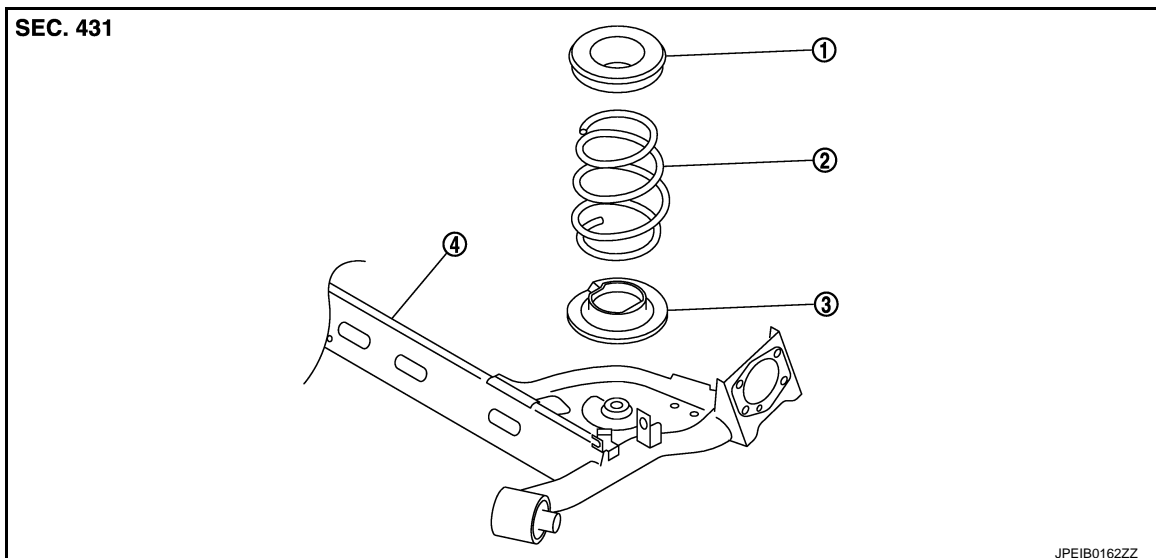

1. Upper rubber seat
2. Coil spring
3. Lower rubber seat
4. Rear suspension beam

Removal and Installation

INFOID:000000009948848

REMOVAL

1. Remove tires with power tool. Refer to [WT-46, "Exploded View"](#).
2. Set jack under rear suspension beam.
CAUTION:
Check the stable condition when using a jack.
3. Remove right and left rear shock absorber mounting bolts (lower side). Refer to [RSU-7, "Exploded View"](#).
4. Slowly lower jack, then remove upper rubber seat, coil spring and lower rubber seat from rear suspension beam.
CAUTION:
Check the stable condition when using a jack.

INSTALLATION

Note the following, and install in the reverse order of removal.

- Install the lower rubber seat a projection (A) is attached as rear suspension beam mounting hole (B).
- Match up lower rubber seat indentions and rear suspension beam grooves and attach.

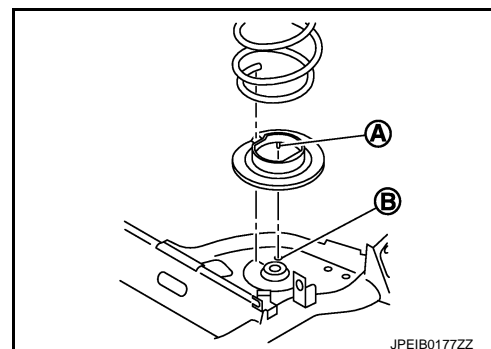

Inspection

INFOID:000000009948849

INSPECTION AFTER REMOVAL

Check rubber seat and coil spring for deformation, crack, and damage. Replace it if necessary.

COIL SPRING

< REMOVAL AND INSTALLATION >

INSPECTION AFTER INSTALLATION

1. Check wheel alignment. Refer to [RSU-6, "Inspection"](#).
2. Adjust neutral position of steering angle sensor. Refer to [BRC-9, "Special Repair Requirement"](#).

REAR SUSPENSION BEAM

< REMOVAL AND INSTALLATION >

REAR SUSPENSION BEAM

Exploded View

INFOID:000000009948850

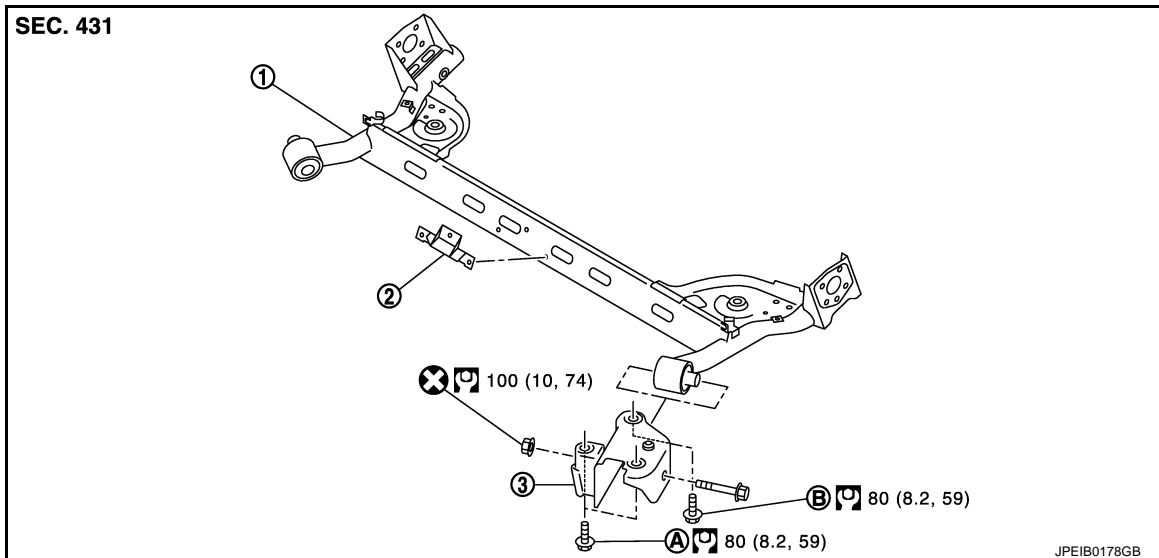

- | | | |
|-------------------------|-------------------------|--------------------------------|
| 1. Rear suspension beam | 2. Brake tube protector | 3. Rear suspension arm bracket |
| A. Flange bolt | B. Except flange bolt | |

Refer to [GI-4, "Components"](#) for symbols in the figure.

Removal and Installation

INFOID:000000009948851

REMOVAL

1. Remove tires with power tool. Refer to [WT-46, "Exploded View"](#).
2. Drain brake fluid. Refer to [BR-10, "Draining"](#).
3. Remove parking brake cable and brake drum from rear suspension beam. Refer to [PB-4, "Exploded View"](#), [BR-39, "Exploded View"](#).
4. Remove wheel sensor and sensor harness. Refer to [BRC-111, "REAR WHEEL SENSOR : Exploded View"](#).
5. Set suitable jack under rear suspension beam.
CAUTION:
Check the stable condition when using a jack.
6. Remove shock absorber mounting bolts (lower side). Refer to [RSU-7, "Exploded View"](#).
7. Remove coil springs. Refer to [RSU-9, "Exploded View"](#).
8. Separate brake hose and brake tube. Refer to [BR-22, "REAR : Exploded View"](#).
9. Remove suspension arm bracket mounting bolts.
10. Slowly lower jack, remove suspension arm bracket and rear suspension beam from vehicle body.
CAUTION:
Check the stable condition when using a jack.
11. Remove wheel hub and bearing assembly. Refer to [RAX-6, "Exploded View"](#).
12. Remove drum brake assembly. Refer to [BR-39, "Exploded View"](#).
13. Remove suspension arm bracket from rear suspension beam.
14. Remove brake tube protector from rear suspension beam.

INSTALLATION

Note the following, and install in the reverse order of removal.

- Perform final tightening of rear suspension beam installation position (rubber bushing), under unladen conditions with tires on level ground.
- Refill with new brake fluid and perform the air bleeding. Refer to [BR-10, "Refilling"](#).

REAR SUSPENSION BEAM

< REMOVAL AND INSTALLATION >

Inspection

INFOID:000000009948852

INSPECTION AFTER REMOVAL

Check rear suspension beam and rear suspension beam bracket for deformation, cracks or damage. Replace the part if necessary.

INSPECTION AFTER INSTALLATION

1. Check wheel sensor harness for proper connection. Refer to [BRC-111, "REAR WHEEL SENSOR : Exploded View"](#).
2. Adjust parking brake. Refer to [PB-3, "Inspection and Adjustment"](#).
3. Check wheel alignment. Refer to [RSU-6, "Inspection"](#).
4. Adjust neutral position of steering angle sensor. Refer to [BRC-9, "Special Repair Requirement"](#).

SERVICE DATA AND SPECIFICATIONS (SDS)

< SERVICE DATA AND SPECIFICATIONS (SDS)

SERVICE DATA AND SPECIFICATIONS (SDS)

SERVICE DATA AND SPECIFICATIONS (SDS)

Wheel Alignment

INFOID:000000009948853

Item		Standard	
Camber Degree minute (Decimal degree)	Minimum	-2° 00' (-2.01°)	
	Nominal	-1° 31' (-1.51°)	
	Maximum	-1° 01' (-1.01°)	
Toe-in	Total toe-in Distance	Minimum	Out 1.0 mm (Out 0.039 in)
		Nominal	In 3.0 mm (In 0.118 in)
		Maximum	In 7.0 mm (In 0.275 in)
	Total toe-angle Degree minute (Decimal degree)	Minimum	Out 0° 06' (Out 0.10°)
		Nominal	In 0° 17' (In 0.28°)
		Maximum	In 0° 39' (In 0.65°)

Measure value under unladen* conditions.

*: Fuel, engine coolant and lubricant are full. Spare tire, jack, hand tools and mats are in designated positions.

Wheelarch Height

INFOID:000000009948854

Item	Standard	
Tire size	195/60R15	195/55R16
Front (Hf)	679 mm (26.73 in)	684 mm (26.93 in)
Rear (Hr)		683 mm (26.89 in)

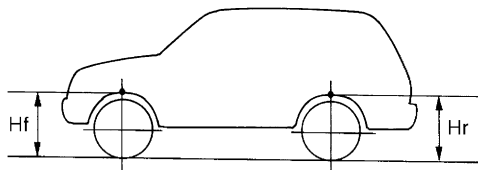

SFA746B

Measure value under unladen* conditions.

*: Fuel, engine coolant and lubricant are full. Spare tire, jack, hand tools and mats are in designated positions.