

SECTION **SB**
SEAT BELT

A
B
C
D
E
F
G
SB
I
J
K
L
M
N
O
P

CONTENTS

PRECAUTION	2	SEAT BELT BUCKLE	7
PRECAUTIONS	2	SEAT BELT BUCKLE : Inspection	7
Precaution for Supplemental Restraint System (SRS) "AIR BAG" and "SEAT BELT PRE-TEN- SIONER"	2	SEAT BELT BUCKLE : Exploded View	8
Precautions for Removing of Battery Terminal	2	SEAT BELT BUCKLE : Removal and Installation.....	8
Precaution for Seat Belt Service	2	REAR SEAT BELT	9
REMOVAL AND INSTALLATION	4	SEAT BELT RETRACTOR	9
FRONT SEAT BELT	4	SEAT BELT RETRACTOR : Inspection	9
SEAT BELT RETRACTOR	4	SEAT BELT RETRACTOR : Exploded View	11
SEAT BELT RETRACTOR : Inspection	4	SEAT BELT RETRACTOR : Removal and Instal- lation	11
SEAT BELT RETRACTOR : Exploded View	6	SEAT BELT BUCKLE	12
SEAT BELT RETRACTOR : Removal and Instal- lation	7	SEAT BELT BUCKLE : Inspection	12
		SEAT BELT BUCKLE : Exploded View	13
		SEAT BELT BUCKLE : Removal and Installation.....	13

PRECAUTIONS

< PRECAUTION >

PRECAUTION

PRECAUTIONS

Precaution for Supplemental Restraint System (SRS) "AIR BAG" and "SEAT BELT PRE-TENSIONER"

INFOID:000000009945626

The Supplemental Restraint System such as "AIR BAG" and "SEAT BELT PRE-TENSIONER", used along with a front seat belt, helps to reduce the risk or severity of injury to the driver and front passenger for certain types of collision. This system includes seat belt switch inputs and dual stage front air bag modules. The SRS system uses the seat belt switches to determine the front air bag deployment, and may only deploy one front air bag, depending on the severity of a collision and whether the front occupants are belted or unbelted. Information necessary to service the system safely is included in the "SRS AIR BAG" and "SEAT BELT" of this Service Manual.

WARNING:

Always observe the following items for preventing accidental activation.

- To avoid rendering the SRS inoperative, which could increase the risk of personal injury or death in the event of a collision that would result in air bag inflation, all maintenance must be performed by an authorized NISSAN/INFINITI dealer.
- Improper maintenance, including incorrect removal and installation of the SRS, can lead to personal injury caused by unintentional activation of the system. For removal of Spiral Cable and Air Bag Module, see "SRS AIR BAG".
- Never use electrical test equipment on any circuit related to the SRS unless instructed to in this Service Manual. SRS wiring harnesses can be identified by yellow and/or orange harnesses or harness connectors.

PRECAUTIONS WHEN USING POWER TOOLS (AIR OR ELECTRIC) AND HAMMERS

WARNING:

Always observe the following items for preventing accidental activation.

- When working near the Air Bag Diagnosis Sensor Unit or other Air Bag System sensors with the ignition ON or engine running, never use air or electric power tools or strike near the sensor(s) with a hammer. Heavy vibration could activate the sensor(s) and deploy the air bag(s), possibly causing serious injury.
- When using air or electric power tools or hammers, always switch the ignition OFF, disconnect the battery, and wait at least 3 minutes before performing any service.

Precautions for Removing of Battery Terminal

INFOID:000000010137657

- When removing the 12V battery terminal, turn OFF the ignition switch and wait at least 30 seconds.

NOTE:

ECU may be active for several tens of seconds after the ignition switch is turned OFF. If the battery terminal is removed before ECU stops, then a DTC detection error or ECU data corruption may occur.

- For vehicles with the 2-batteries, be sure to connect the main battery and the sub battery before turning ON the ignition switch.

NOTE:

If the ignition switch is turned ON with any one of the terminals of main battery and sub battery disconnected, then DTC may be detected.

- After installing the 12V battery, always check "Self Diagnosis Result" of all ECUs and erase DTC.

NOTE:

The removal of 12V battery may cause a DTC detection error.

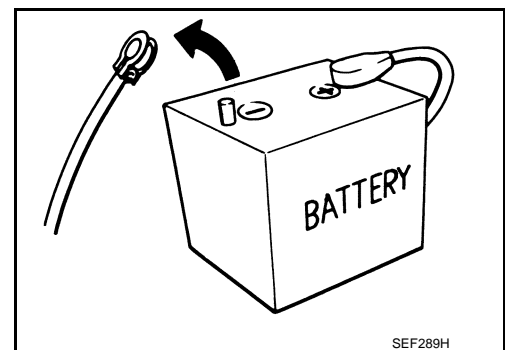

Precaution for Seat Belt Service

INFOID:000000009945627

CAUTION:

- Before removing the front seat belt pre-tensioner assembly, turn the ignition switch off, disconnect battery negative terminal and wait at least 3 minutes.
- Do not use electrical test equipment for front seat belt pre-tensioner connector.

PRECAUTIONS

< PRECAUTION >

- After replacing or reinstalling front seat belt pre-tensioner assembly, or reconnecting front seat belt pre-tensioner connector, check the system function. Refer to [SRC-18, "Diagnosis Description"](#).
- Do not use disassembled buckle or seat belt assembly.
- Replace anchor bolts if they are deformed or worn out.
- Never oil tongue and buckle.
- If any component of seat belt assembly is questionable, do not repair. Replace the entire seat belt assembly.
- If webbing is cut, frayed or damaged, replace seat belt assembly.
- When replacing seat belt assembly, use a genuine NISSAN seat belt assembly.

AFTER A COLLISION

WARNING:

Inspect all seat belt assemblies including retractors and attached hardware after any collision. NISSAN recommends that all seat belt assemblies in use during a collision be replaced unless the collision was minor and the belts show no damage and continue to operate properly. Failure to do so could result in serious personal injury in an accident. Seat belt assemblies not in use during a collision should also be replaced if either damage or improper operation is noted. Seat belt pre-tensioners should be replaced even if the seat belts are not in use during a frontal collision in which the air bags are deployed.

Replace any seat belt assembly (including anchor bolts) if:

- The seat belt was in use at the time of a collision (except for minor collisions and the belts, retractors and buckles show no damage and continue to operate properly).
- The seat belt was damaged in an accident (i.e. torn webbing, bent retractor or guide).
- The seat belt attaching point was damaged in an accident. Inspect the seat belt attaching area for damage or distortion and repair as necessary before installing a new seat belt assembly.
- Anchor bolts are deformed or worn out.
- The front seat belt pre-tensioner should be replaced even if the seat belts are not in use during the collision in which the air bags are deployed.

A

B

C

D

E

F

G

SB

I

J

K

L

M

N

O

P

FRONT SEAT BELT

< REMOVAL AND INSTALLATION >

REMOVAL AND INSTALLATION

FRONT SEAT BELT

SEAT BELT RETRACTOR

SEAT BELT RETRACTOR : Inspection

INFOID:000000009945628

AFTER A COLLISION

WARNING:

Inspect all seat belt assemblies including retractors and attached hardware after any collision. NISSAN/INFINITI recommends that all seat belt assemblies in use during a collision be replaced unless the collision was minor and the belts show no damage and continue to operate properly. Failure to do so could result in serious personal injury in an accident. Seat belt assemblies not in use during a collision should also be replaced if either damage or improper operation was noted. Seat belt pre-tensioners should be replaced even if the seat belts were not in use during a frontal collision in which the air bags were deployed.

Replace any seat belt assembly (including anchor bolts) if:

- The seat belt is in use at the time of a collision (except for minor collisions and the belts, retractors and buckles show no damage and continue to operate properly).
- The seat belt is damaged in an accident (i.e. torn webbing, bent retractor or guide, etc.).
- The seat belt attaching point is damaged in an accident. Inspect the seat belt attaching area for damage or distortion and repair if necessary before installing a new seat belt assembly.
- Anchor bolts are deformed or worn out.
- The seat belt pre-tensioners must be replaced even if the seat belts were not in use during the collision in which the air bags were deployed.

PRELIMINARY CHECKS

1. Check the seat belt warning lamp for proper operation as per the following:
 - a. Turn ignition switch ON. The seat belt warning lamp should illuminate.
 - b. Fasten driver seat belt. The seat belt warning lamp should turn OFF.
2. If the air bag warning lamp is blinking, perform self-diagnosis with CONSULT and air bag warning lamp. Refer to [SRC-18, "Diagnosis Description"](#).
3. Check that the seat belt retractor, seat belt anchor and buckle bolts are tightened firmly.
4. Check the shoulder seat belt guide and shoulder belt height adjuster for front seats. Check that guide swivels freely and that webbing lays flat and does not bind in guide. Check that height adjuster operates properly and holds securely.
5. Check retractor operation:
 - a. Fully extend the seat belt webbing and check for twists, tears or other damage.
 - b. Allow the seat belt to retract. Check that webbing returns smoothly and completely into the retractor. If the seat belt does not return smoothly, wipe the inside of the loops with a clean paper cloth. Dirt build-up in the loops of the upper anchors can cause the seat belts to retract slowly.
 - c. Fasten the seat belt. Check that seat belt returns smoothly and completely to the retractor. If the webbing does not return smoothly, the cause may be an accumulation of dust or dirt. Use the "SEAT BELT TAPE SET" and perform the following steps.

Inspect the front seat belt shoulder anchor

1. Pull the seat belt out to a length of 500 mm (19.69 in) or more.
 2. Fix the seat belt at the center pillar webbing opening with a clip or other device.
 3. Pass a thin wire through the shoulder anchor webbing opening. Hold both ends of the wire and pull it tightly while moving it up and down several times along the webbing opening surface to remove dirt stuck there.
 4. Any dirt that cannot be removed with the wire can be removed by cleaning the opening with a clean cloth.
 5. Apply tape at the point where the webbing contacts the shoulder anchor webbing opening.

NOTE:
Apply the tape so that there is no slack or wrinkling.
 6. Remove the clip fixing the seat belt and check that the webbing returns smoothly.
6. Repeat steps above if necessary to check the other seat belts.

FRONT SEAT BELT

< REMOVAL AND INSTALLATION >

SEAT BELT RETRACTOR ON-VEHICLE CHECK

Emergency Locking Retractors (ELR) and Automatic Locking Retractors (ALR)

NOTE:

All seat belt retractors are Emergency Locking Retractors (ELR) type. In an emergency (sudden stop) the retractor will lock and prevent the webbing from extending any further. All 3-point type seat belt retractors except the driver seat belt also have an Automatic Locking Retractors (ALR) mode. The ALR mode (also called child restraint mode) is used when installing child seats. The ALR mode is activated when the seat belt is fully extended. When the webbing is then retracted partially, the ALR mode automatically locks the seat belt in a specific position so the webbing cannot be extended any further. To cancel the ALR mode, allow the seat belt to fully wind back into the retractor.

Check the seat belt retractors with the following test(s) to determine if a retractor assembly is operating properly.

ELR Function Stationary Check

Grasp the shoulder webbing and pull forward quickly. The retractor should lock and prevent the belt from extending further.

ALR Function Stationary Check

1. Pull out the entire length of seat belt from retractor until a click is heard.
2. Retract the webbing partially. A clicking noise should be heard as the webbing retracts indicating that the retractor is in the Automatic Locking Retractors (ALR) mode.
3. Grasp the seat belt and try to pull out the retractor. The webbing must lock and not extend any further. If it does not operate normally, replace the retractor assembly.
4. Allow the entire length of the webbing to retract to cancel the automatic locking mode.

ELR Function Moving Check

WARNING:

Perform the following test in a safe, open area clear of other vehicles and obstructions (for example, a large, empty parking lot). Road surface must be paved and dry. Never perform the following test on wet or gravel roads or on public streets and highways. This could result in an accident and serious personal injury. The driver and passenger must be prepared to brace themselves in the event that the retractor does not lock.

1. Fasten driver seat belt. Buckle a passenger into the seat for the belt that is to be tested.
2. Proceed to the designated safe area.
3. Drive the vehicle at approximately 16 km/h (10 MPH). Notify any passengers of a pending sudden stop and the driver and passenger must be prepared to brace themselves in the event that the retractor does not lock. Apply brakes firmly and make a very hard stop.

During stopping, seat belts should lock and not be extended. If the seat belt retractor assembly does not lock, perform the retractor off-vehicle check.

SEAT BELT RETRACTOR OFF-VEHICLE CHECK

1. Remove the front seat belt retractor. Refer to [SB-7, "SEAT BELT RETRACTOR : Removal and Installation"](#).
2. Slowly pull out webbing while tilting the retractor assembly forward from the mounted position without twisting the retractor assembly as shown in the figure.
 - The webbing can be pulled out when the angle (A) is 12 degrees or less.
 - The webbing cannot be pulled out when the angle (B) is 13 degrees or more.

A and B : Tilting angles

← : Vehicle front

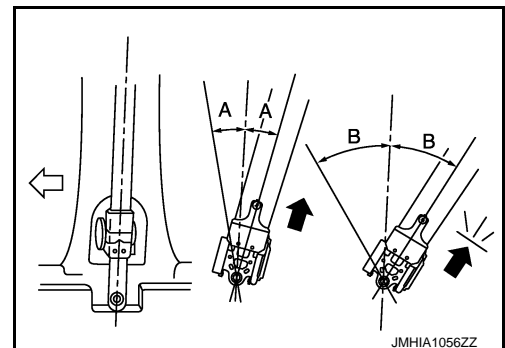

3. Replace the seat belt assembly if it does not operate normally.

FRONT SEAT BELT

< REMOVAL AND INSTALLATION >

SEAT BELT RETRACTOR : Exploded View

INFOID:000000009945629

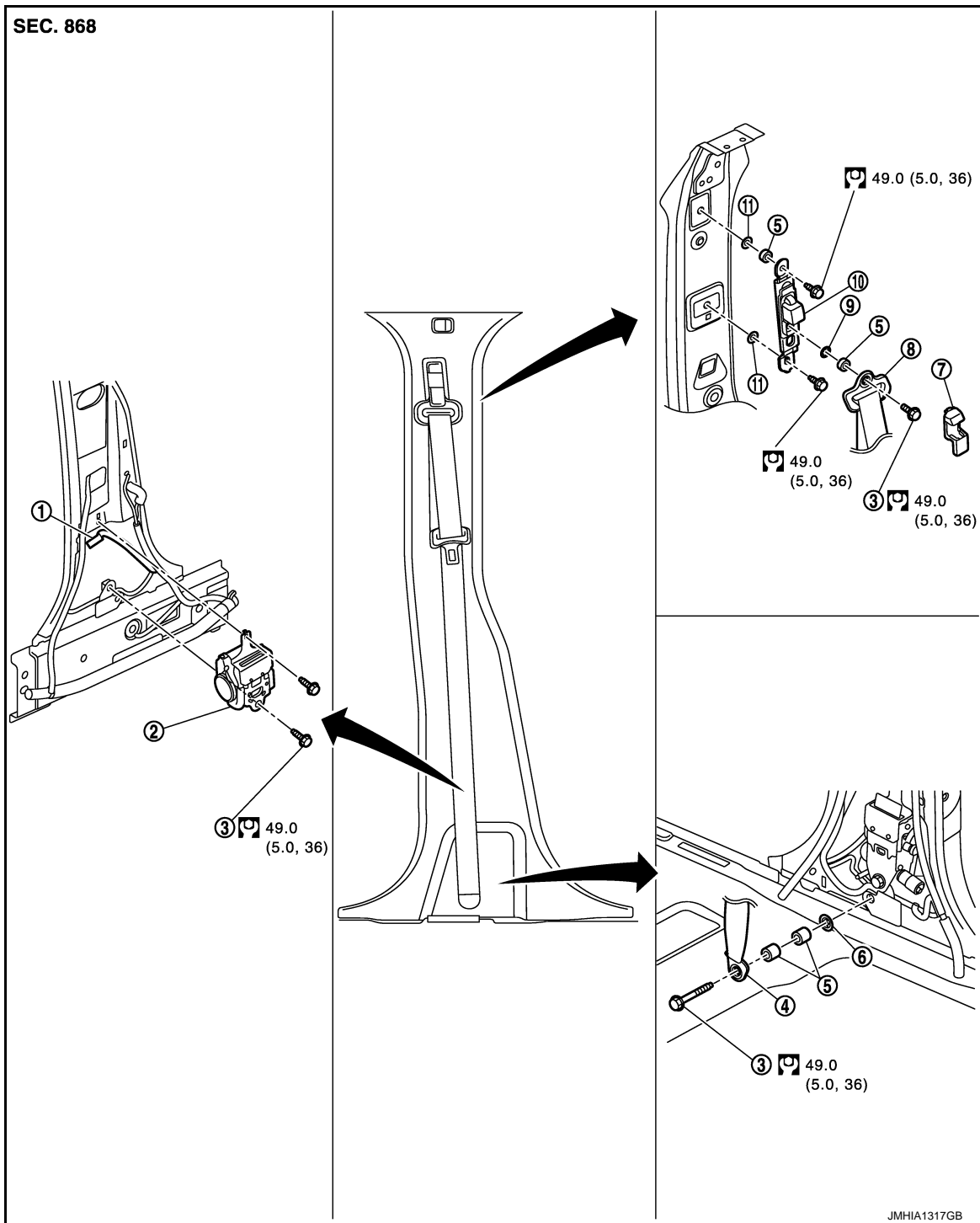

- | | | |
|--------------------------------------|--------------------------------------|---------------------|
| 1. Seat belt pre-tensioner connector | 2. Seat belt pre-tensioner retractor | 3. Anchor bolt |
| 4. Outer anchor | 5. Spacer | 6. Locking washer |
| 7. Adjuster cover | 8. Shoulder anchor | 9. Retaining washer |
| 10. Seat belt adjuster | 11. Fiber washer | |

 : N·m (kg-m, ft-lb)

JMHIA1317GB

FRONT SEAT BELT

< REMOVAL AND INSTALLATION >

SEAT BELT RETRACTOR : Removal and Installation

INFOID:000000009945630

REMOVAL

CAUTION:

Before servicing SRS, turn the ignition switch OFF, disconnect battery negative terminal and wait at least 3 minutes.

REMOVAL

1. Remove shoulder anchor.
 - Remove shoulder anchor cover.
 - Remove fixing anchor bolt of the shoulder anchor.
2. Remove outer anchor mounting bolt.
3. Remove seat belt pre-tensioner retractor.
 - Remove center pillar lower finisher. Refer to [INT-16. "Removal and Installation"](#).
 - Disconnect the seat belt pre-tensioner connector.

CAUTION:

- For installing/removing seat belt pre-tensioner connector, insert thin screwdriver wrapped in tape into notch, lift lock and remove connector.
- Install connector with lock raised, and push lock into connector.
- After installing the connector, check that the lock is pushed securely into it.

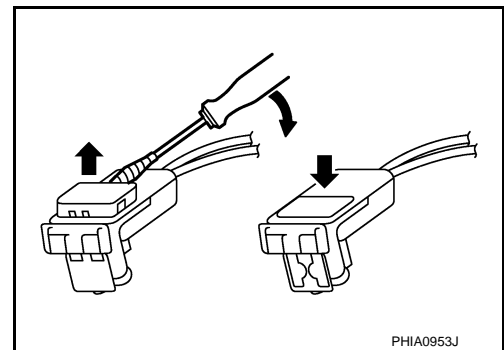

- Remove the fixing bolt and anchor bolt of the seat belt pre-tensioner retractor.
4. Remove the seat belt adjuster.
 - Remove the fixing bolts of the seat belt adjuster.

INSTALLATION

Install in the reverse order of removal.

SEAT BELT BUCKLE

SEAT BELT BUCKLE : Inspection

INFOID:000000009945631

AFTER A COLLISION

WARNING:

Inspect all seat belt assemblies including retractors and attached hardware after any collision. NISSAN/INFINITI recommends that all seat belt assemblies in use during a collision be replaced unless the collision was minor and the belts show no damage and continue to operate properly. Failure to do so could result in serious personal injury in an accident. Seat belt assemblies not in use during a collision should also be replaced if either damage or improper operation was noted. Seat belt pre-tensioners should be replaced even if the seat belts were not in use during a frontal collision in which the air bags were deployed.

Replace any seat belt assembly (including anchor bolts) if:

- The seat belt is in use at the time of a collision (except for minor collisions and the belts, retractors and buckles show no damage and continue to operate properly).
- The seat belt is damaged in an accident (i.e. torn webbing, bent retractor or guide, etc.).
- The seat belt attaching point is damaged in an accident. Inspect the seat belt attaching area for damage or distortion and repair if necessary before installing a new seat belt assembly.
- Anchor bolts are deformed or worn out.
- The seat belt pre-tensioner must be replaced even if the seat belts were not in use during the collision in which the air bags were deployed.

PRELIMINARY CHECKS

1. Check the seat belt warning lamp for proper operation as per the following:

FRONT SEAT BELT

< REMOVAL AND INSTALLATION >

- a. Turn ignition switch ON. The seat belt warning lamp should illuminate.
- b. Fasten driver seat belt. The seat belt warning lamp should turn OFF.
2. If the air bag warning lamp is blinking, perform self-diagnosis using CONSULT and air bag warning lamp. Refer to [SRC-18. "Diagnosis Description"](#).
3. Check that the seat belt retractor, seat belt anchor and buckle bolts are tightened firmly.
4. Repeat steps above if necessary to check the other seat belts.

SEAT BELT BUCKLE : Exploded View

INFOID:000000009945632

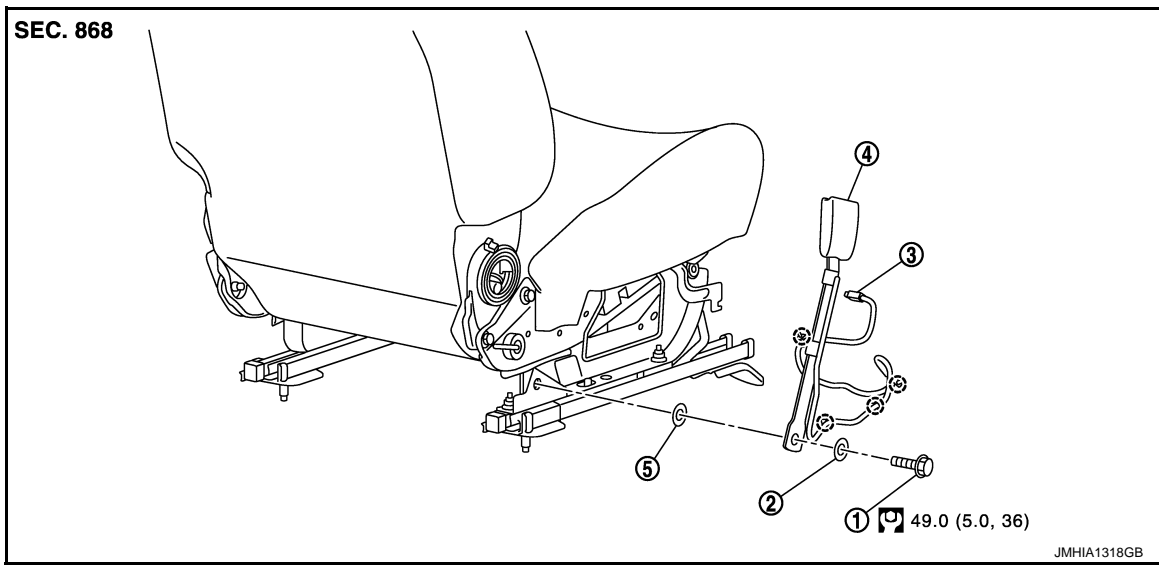

- | | | |
|---------------------|---------------------|---------------------------------------|
| 1. Anchor bolt | 2. Wave washer | 3. Seat belt buckle harness connector |
| 4. Seat belt buckle | 5. Retaining washer | |

○ : Clip

⊕ : N·m (kg-m, ft-lb)

SEAT BELT BUCKLE : Removal and Installation

INFOID:000000009945633

REMOVAL

Remove the seat belt buckle.

- Remove the front seat from vehicle. Refer to [SE-14. "Removal and Installation"](#). (for ease of tool operation in narrow space.)
- Remove seat cushion inner finisher. Refer to [SE-12. "Exploded View"](#).
- Remove the seat belt buckle harness connector and harness clamp.
- Remove the fixing anchor bolt of the seat belt buckle.

INSTALLATION

Install in the reverse order of removal.

REAR SEAT BELT

< REMOVAL AND INSTALLATION >

REAR SEAT BELT

SEAT BELT RETRACTOR

SEAT BELT RETRACTOR : Inspection

INFOID:000000009945634

AFTER A COLLISION

WARNING:

Inspect all seat belt assemblies including retractors and attached hardware after any collision. NISSAN/INFINITI recommends that all seat belt assemblies in use during a collision be replaced unless the collision was minor and the belts show no damage and continue to operate properly. Failure to do so could result in serious personal injury in an accident. Seat belt assemblies not in use during a collision should also be replaced if either damage or improper operation was noted. Seat belt pre-tensioners should be replaced even if the seat belts were not in use during a frontal collision in which the air bags were deployed.

Replace any seat belt assembly (including anchor bolts) if:

- The seat belt is in use at the time of a collision (except for minor collisions and the belts, retractors and buckles show no damage and continue to operate properly).
- The seat belt is damaged in an accident (i.e. torn webbing, bent retractor or guide, etc.).
- The seat belt attaching point is damaged in an accident. Inspect the seat belt attaching area for damage or distortion and repair if necessary before installing a new seat belt assembly.
- Anchor bolts are deformed or worn out.
- The seat belt pre-tensioners must be replaced even if the seat belts were not in use during the collision in which the air bags were deployed.

PRELIMINARY CHECKS

1. Check that the seat belt retractor, seat belt anchor and buckle bolts are tightened firmly.
2. Check retractor operation:
 - a. Fully extend the seat belt webbing and check for twists, tears or other damage.
 - b. Allow the seat belt to retract. Check that webbing returns smoothly and completely into the retractor. If the seat belt does not return smoothly, wipe the inside of the loops with a clean paper cloth. Dirt build-up in the loops of that upper anchors can cause the seat belts to retract slowly.
 - c. Fasten the seat belt. Check that seat belt returns smoothly and completely to the retractor. If the webbing does not return smoothly, the cause may be an accumulation of dust or dirt. Use the "SEAT BELT TAPE SET" and perform the following steps.
3. Repeat steps above if necessary to check the other seat belts.

SEAT BELT RETRACTOR ON-VEHICLE CHECK

Emergency Locking Retractors (ELR) and Automatic Locking Retractors (ALR)

NOTE:

All seat belt retractors are Emergency Locking Retractors (ELR) type. In an emergency (sudden stop) the retractor will lock and prevent the webbing from extending any further. All 3-point type seat belt retractors except the driver seat belt also have an Automatic Locking Retractors (ALR) mode. The ALR mode (also called child restraint mode) is used when installing child seats. The ALR mode is activated when the seat belt is fully extended. When the webbing is then retracted partially, the ALR mode automatically locks the seat belt in a specific position so the webbing cannot be extended any further. To cancel the ALR mode, allow the seat belt to fully wind back into the retractor.

Check the seat belt retractors with the following test(s) to determine if a retractor assembly is operating properly.

ELR Function Stationary Check

Grasp the shoulder webbing and pull forward quickly. The retractor should lock and prevent the belt from extending further.

ALR Function Stationary Check

1. Pull out the entire length of seat belt from retractor until a click is heard.
2. Retract the webbing partially. A clicking noise should be heard as the webbing retracts indicating that the retractor is in the Automatic Locking Retractors (ALR) mode.

REAR SEAT BELT

< REMOVAL AND INSTALLATION >

3. Grasp the seat belt and try to pull out the retractor. The webbing must lock and not extend any further. If it does not operate normally, replace the retractor assembly.
4. Allow the entire length of the webbing to retract to cancel the automatic locking mode.

ELR Function Moving Check

WARNING:

Perform the following test in a safe, open area clear of other vehicles and obstructions (for example, a large, empty parking lot). Road surface must be paved and dry. Never perform the following test on wet or gravel roads or on public streets and highways. This could result in an accident and serious personal injury. The driver and passenger must be prepared to brace themselves in the event that the retractor does not lock.

1. Fasten driver seat belt. Buckle a passenger into the seat for the belt that is to be tested.
2. Proceed to the designated safe area.
3. Drive the vehicle at approximately 16 km/h (10 MPH). Notify any passengers of a pending sudden stop and the driver and passenger must be prepared to brace themselves in the event that the retractor does not lock. Apply brakes firmly and make a very hard stop.

During stopping, seat belts should lock and not be extended. If the seat belt retractor assembly does not lock, perform the retractor off-vehicle check.

SEAT BELT RETRACTOR OFF-VEHICLE CHECK

1. Remove the rear seat belt retractor. Refer to [SB-11, "SEAT BELT RETRACTOR : Removal and Installation"](#).
2. Slowly pull out webbing while tilting the retractor assembly forward from the mounted position without twisting the retractor assembly as shown in the figure.

a. Outer seat belt retractor

- The webbing can be pulled out when the angle (A) is 12 degrees or less.
- The webbing cannot be pulled out when the angle (B) is 13 degrees or more.

A and B : Tilting angles

← : Vehicle front

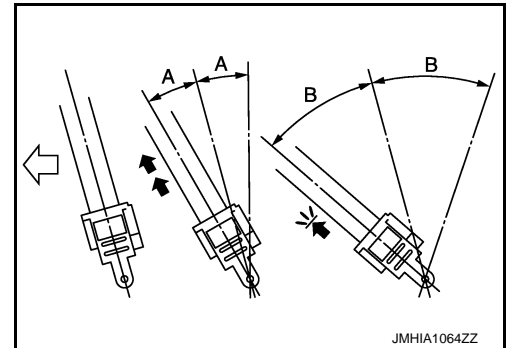

b. Center seat belt retractor

- The webbing can be pulled out when the angle (A) is 12 degrees or less.
- The webbing cannot be pulled out when the angle (B) is 13 degrees or more.

A and B : Tilting angles

← : Vehicle front

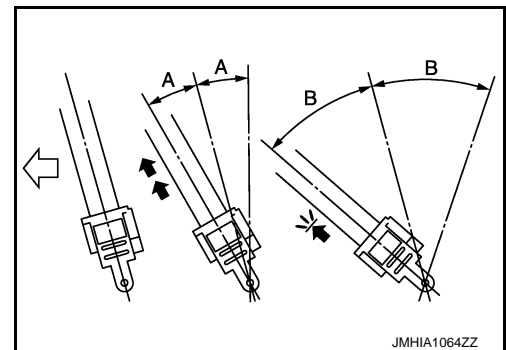

3. Replace the seat belt assembly if it does not operate normally.

REAR SEAT BELT

< REMOVAL AND INSTALLATION >

SEAT BELT RETRACTOR : Exploded View

INFOID:000000009945635

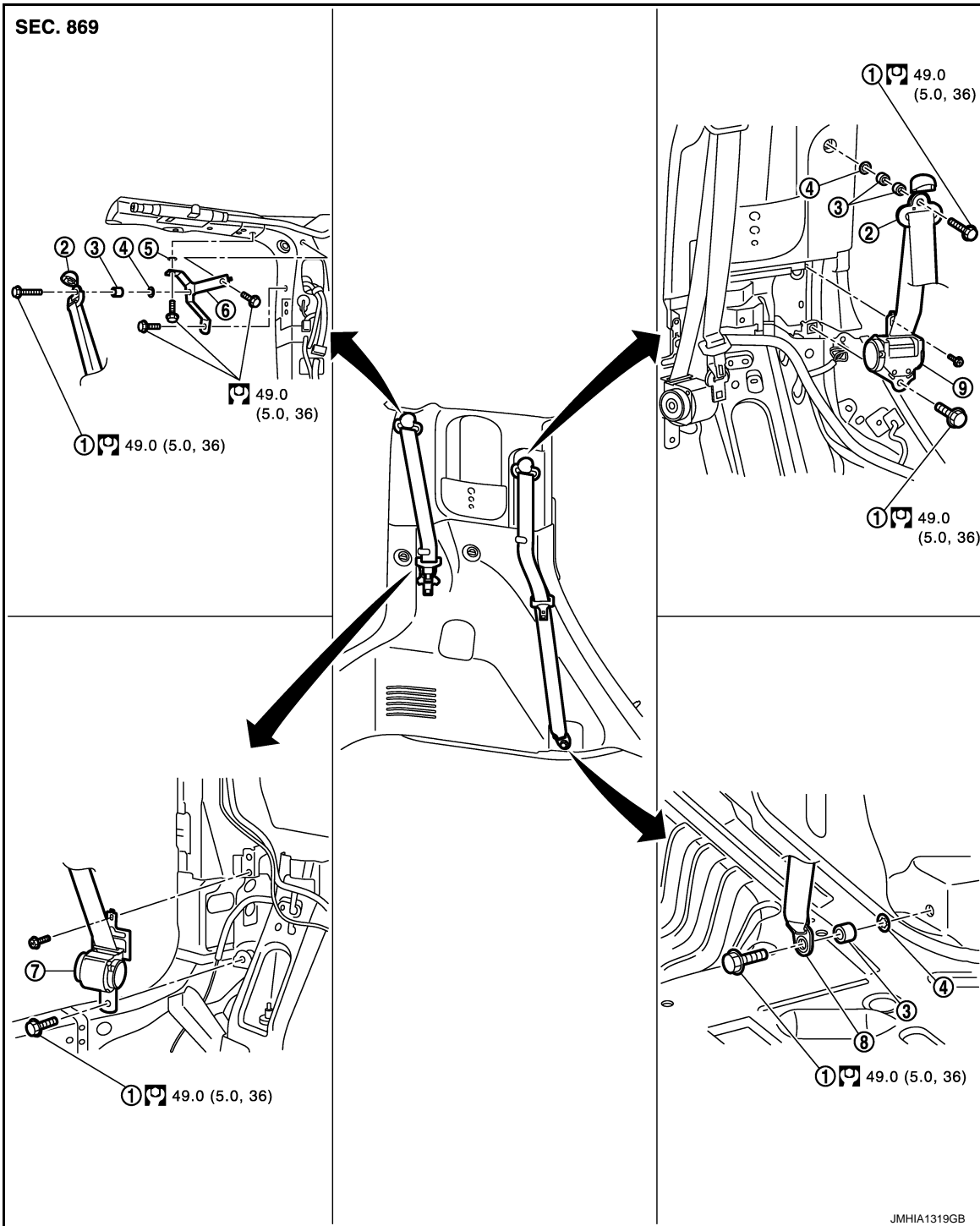

- | | | |
|-------------------------------|--------------------|------------------------------|
| 1. Anchor bolt | 2. Shoulder anchor | 3. Spacer |
| 4. Locking washer | 5. Fiber washer | 6. Center seat belt buckle |
| 7. Center seat belt retractor | 8. Outer anchor | 9. Outer seat belt retractor |

: N·m (kg·m, ft·lb)

SEAT BELT RETRACTOR : Removal and Installation

INFOID:000000009945636

REMOVAL

A
B
C
D
E
F
G
SB
I
J
K
L
M
N
O
P

REAR SEAT BELT

< REMOVAL AND INSTALLATION >

OUTER SEAT BELT RETRACTOR

1. Remove the outer anchor.
 - Slide the rear seat assembly to front most position.
 - Remove the outer anchor fixing anchor bolt.
2. Remove the shoulder anchor bolt.
3. Remove the outer seat belt retractor.
 - Remove the luggage side lower finisher. Refer to [INT-24, "Removal and Installation"](#).
 - Remove the outer seat belt anchor bolt.

CENTER SEAT BELT RETRACTOR

1. Remove shoulder anchor bolt.
2. Remove center seat belt retractor.
 - Slide rear seat assembly to front most position.
 - Remove luggage side lower finisher LH. Refer to [INT-24, "Removal and Installation"](#).
 - Remove center seat belt retractor mounting bolt.

INSTALLATION

Install in the reverse order of removal.

SEAT BELT BUCKLE

SEAT BELT BUCKLE : Inspection

INFOID:000000009945637

AFTER A COLLISION

WARNING:

Inspect all seat belt assemblies including retractors and attached hardware after any collision. NISSAN/INFINITI recommends that all seat belt assemblies in use during a collision be replaced unless the collision was minor and the belts show no damage and continue to operate properly. Failure to do so could result in serious personal injury in an accident. Seat belt assemblies not in use during a collision should also be replaced if either damage or improper operation was noted. Seat belt pre-tensioners should be replaced even if the seat belts were not in use during a frontal collision in which the air bags were deployed.

Replace any seat belt assembly (including anchor bolts) if:

- The seat belt is in use at the time of a collision (except for minor collisions and the belts, retractors and buckles show no damage and continue to operate properly).
- The seat belt is damaged in an accident. (i.e. torn webbing, bent retractor or guide, etc.)
- The seat belt attaching point is damaged in an accident. Inspect the seat belt attaching area for damage or distortion and repair if necessary before installing a new seat belt assembly.
- Anchor bolts are deformed or worn out.
- The seat belt pre-tensioner must be replaced even if the seat belts were not in use during the collision in which the air bags are deployed.

PRELIMINARY CHECKS

1. Check that the seat belt retractor, seat belt anchor and buckle bolts are tightened firmly.
2. Repeat step above if necessary to check the other seat belts.

REAR SEAT BELT

< REMOVAL AND INSTALLATION >

SEAT BELT BUCKLE : Exploded View

INFOID:000000009945638

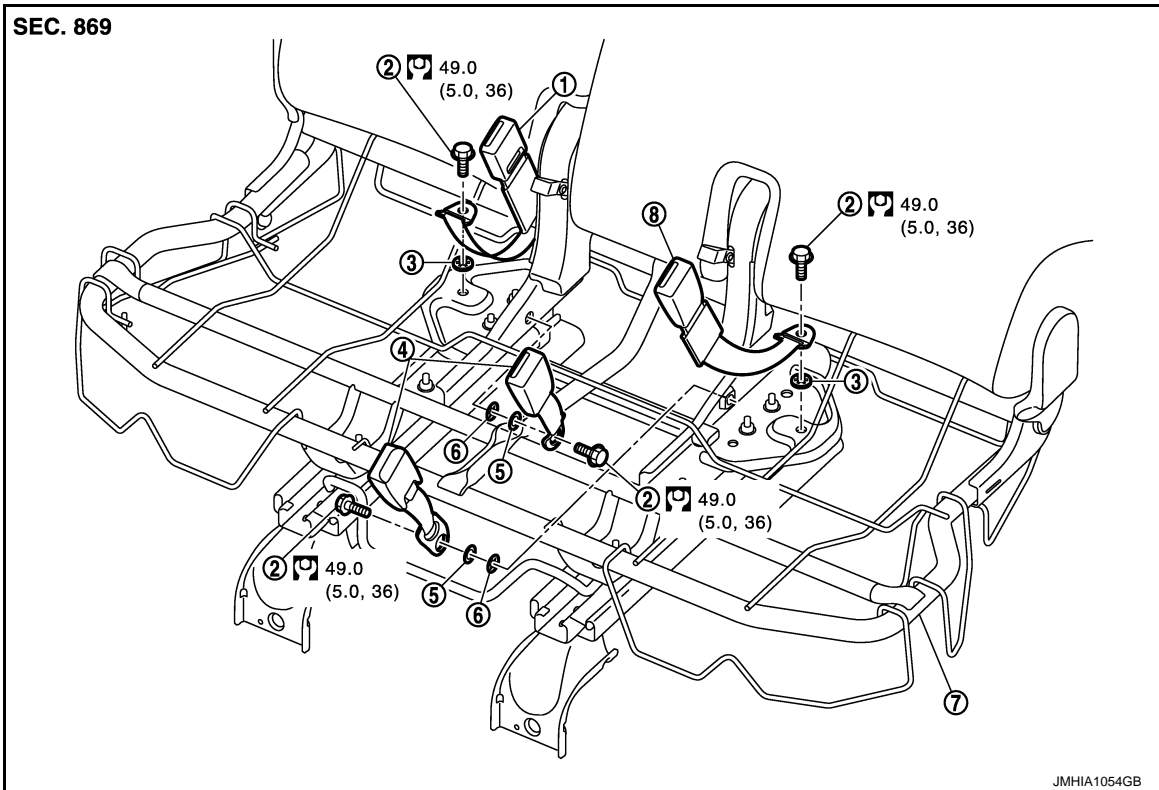

- | | | |
|--------------------------------------|----------------------------|-------------------|
| 1. Center seat belt connector buckle | 2. Anchor bolt | 3. Fiber washer |
| 4. Outer seat belt buckle | 5. Washer | 6. Locking washer |
| 7. Rear seat cushion frame | 8. Center seat belt buckle | |

 : N·m (kg·m, ft·lb)

SEAT BELT BUCKLE : Removal and Installation

INFOID:000000009945639

REMOVAL

Remove the center and outer seat belt buckle.

- Remove the rear seat cushion. Refer to [SE-17. "Exploded View"](#).
- Remove the seat belt anchor bolt.

INSTALLATION

Install in the reverse order of removal.