

SECTION **FAX**  
FRONT AXLE

A  
B  
C

FAX

CONTENTS

E

**2WD**

**SYMPTOM DIAGNOSIS** ..... 3

**NOISE, VIBRATION AND HARSHNESS (NVH) TROUBLESHOOTING** ..... 3  
NVH Troubleshooting Chart .....3

**PREPARATION** ..... 4

**PREPARATION** ..... 4  
Commercial Service Tool .....4

**ON-VEHICLE MAINTENANCE** ..... 5

**FRONT WHEEL HUB AND KNUCKLE** ..... 5  
Inspection .....5

**ON-VEHICLE REPAIR** ..... 6

**FRONT WHEEL HUB AND KNUCKLE** ..... 6  
Exploded View .....6  
Removal and Installation .....6  
Inspection .....7

**SERVICE DATA AND SPECIFICATIONS (SDS)** ..... 8

**SERVICE DATA AND SPECIFICATIONS (SDS)** ..... 8  
Wheel Bearing .....8

**AWD**

**SYMPTOM DIAGNOSIS** ..... 9

**NOISE, VIBRATION AND HARSHNESS (NVH) TROUBLESHOOTING** ..... 9  
NVH Troubleshooting Chart .....9

**PRECAUTION** .....10

**PRECAUTIONS** .....10

Precaution for Supplemental Restraint System (SRS) "AIR BAG" and "SEAT BELT PRE-TENSIONER" .....10

Precaution Necessary for Steering Wheel Rotation after Battery Disconnect .....10

Precautions for Drive Shaft .....10

**PREPARATION** .....12

**PREPARATION** .....12  
Special Service Tool .....12  
Commercial Service Tool .....13

**ON-VEHICLE MAINTENANCE** .....14

**FRONT WHEEL HUB AND KNUCKLE** .....14  
Inspection .....14

**FRONT DRIVE SHAFT** .....15  
Inspection .....15

**ON-VEHICLE REPAIR** .....16

**FRONT WHEEL HUB AND KNUCKLE** .....16  
Exploded View .....16  
Removal and Installation .....16  
Inspection .....17

**FRONT DRIVE SHAFT BOOT** .....18  
Exploded View .....18

**WHEEL SIDE** .....19  
WHEEL SIDE : Removal and Installation .....19

**FINAL DRIVE SIDE** .....22  
FINAL DRIVE SIDE : Removal and Installation .....22  
Inspection .....22

**FRONT DRIVE SHAFT** .....23  
Exploded View .....23

**LEFT SIDE** .....24  
LEFT SIDE : Removal and Installation .....24

F

G

H

I

J

K

L

M

N

O

P

---

|  |    |
|--|----|
| <b>RIGHT SIDE</b> .....                        | 24 |
| RIGHT SIDE : Removal and Installation .....    | 24 |
| <b>WHEEL SIDE</b> .....                        | 25 |
| WHEEL SIDE : Disassembly and Assembly .....    | 25 |
| <b>FINAL DRIVE SIDE</b> .....                  | 27 |
| FINAL DRIVE SIDE : Disassembly and Assembly... | 27 |
| Inspection .....                               | 30 |

---

|  |    |
|--|----|
| <b>SERVICE DATA AND SPECIFICATIONS (SDS)</b> ..... | 32 |
|--|----|

|  |    |
|--|----|
| <b>SERVICE DATA AND SPECIFICATIONS (SDS)</b> ..... | 32 |
| Wheel Bearing .....                                | 32 |
| Drive Shaft .....                                  | 32 |

# NOISE, VIBRATION AND HARSHNESS (NVH) TROUBLESHOOTING

< SYMPTOM DIAGNOSIS >

[2WD]

## SYMPTOM DIAGNOSIS

### NOISE, VIBRATION AND HARSHNESS (NVH) TROUBLESHOOTING

#### NVH Troubleshooting Chart

INFOID:000000003138922

Use chart below to help you find the cause of the symptom. If necessary, repair or replace these parts.

| Reference page                     |            | <a href="#">FAX-6</a>            | —                  | <a href="#">FAX-5</a> | NVH in FAX and FSU sections     | NVH in WT section | NVH in WT section | Refer to DRIVE SHAFT in this chart. | NVH in BR section | NVH in ST section |
|------------------------------------|------------|----------------------------------|--------------------|-----------------------|---------------------------------|-------------------|-------------------|-------------------------------------|-------------------|-------------------|
| Possible cause and SUSPECTED PARTS |            | Improper installation, looseness | Parts interference | Wheel bearing damage  | FRONT AXLE AND FRONT SUSPENSION | TIRE              | ROAD WHEEL        | DRIVE SHAFT                         | BRAKE             | STEERING          |
| Symptom                            | FRONT AXLE | Noise                            | x                  | x                     | x                               | x                 | x                 | x                                   | x                 | x                 |
|                                    |            | Shake                            | x                  | x                     | x                               | x                 | x                 | x                                   | x                 | x                 |
|                                    |            | Vibration                        | x                  | x                     | x                               | x                 |                   | x                                   |                   | x                 |
|                                    |            | Shimmy                           | x                  | x                     |                                 | x                 | x                 |                                     | x                 | x                 |
|                                    |            | Judder                           | x                  |                       |                                 | x                 | x                 |                                     | x                 | x                 |
|                                    |            | Poor quality ride or handling    | x                  | x                     |                                 | x                 | x                 |                                     |                   |                   |

x: Applicable

A  
B  
C  
E  
F  
G  
H  
I  
J  
K  
L  
M  
N  
O  
P

FAX

# PREPARATION

< PREPARATION >

[2WD]

## PREPARATION

### PREPARATION

#### Commercial Service Tool

INFOID:000000003138923

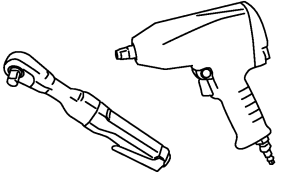
| Tool name  | Description   |
|--|---|
| <p data-bbox="162 415 272 441">Power tool</p>  <p data-bbox="846 632 919 646">PBIC0190E</p> | <p data-bbox="1008 415 1260 441">Loosening bolts and nuts</p> |

# FRONT WHEEL HUB AND KNUCKLE

< ON-VEHICLE MAINTENANCE >

[2WD]

## ON-VEHICLE MAINTENANCE

### FRONT WHEEL HUB AND KNUCKLE

#### Inspection

INFOID:000000003138924

#### MOUNTING INSPECTION

Make sure that the mounting conditions (looseness, backlash) of each component and component conditions (wear, damage) are normal.

#### WHEEL BEARING INSPECTION

- Move wheel hub and bearing assembly in the axial direction by hand. Make sure there is no looseness of wheel bearing.

#### Standard

**Axial end play** : Refer to [FAX-8, "Wheel Bearing"](#).

- Rotate wheel hub and make sure that is no unusual noise or other irregular conditions. If there is any of irregular conditions, replace wheel hub and bearing assembly.

A  
B  
C  
FAX  
E  
F  
G  
H  
I  
J  
K  
L  
M  
N  
O  
P

# FRONT WHEEL HUB AND KNUCKLE

< ON-VEHICLE REPAIR >

[2WD]

## ON-VEHICLE REPAIR

### FRONT WHEEL HUB AND KNUCKLE

#### Exploded View

INFOID:000000003138925

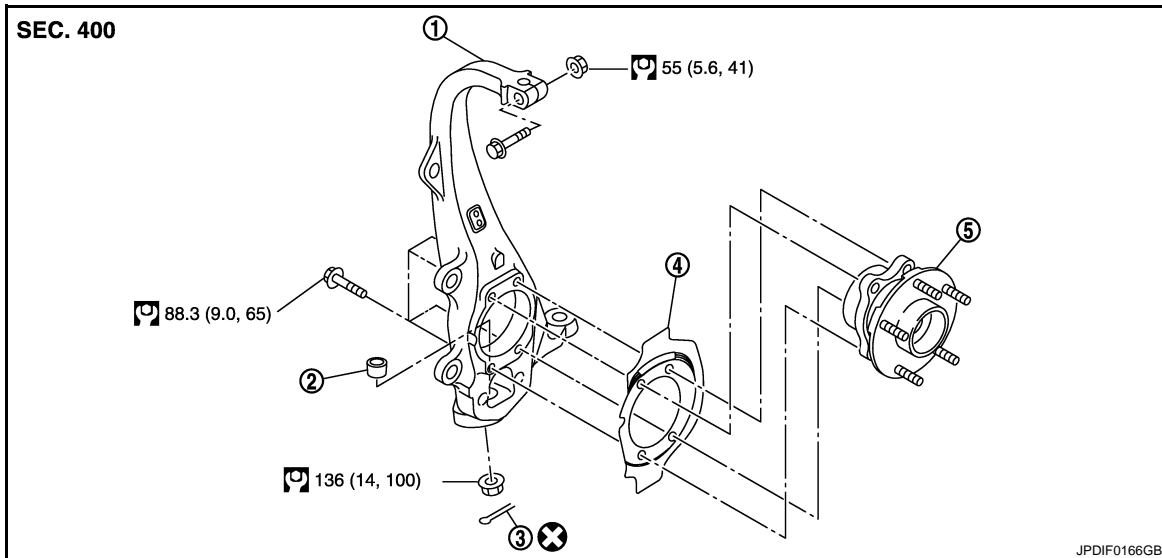

- |                     |                                   |               |
|---------------------|-----------------------------------|---------------|
| 1. Steering knuckle | 2. Ball seat                      | 3. Cotter pin |
| 4. Splash guard     | 5. Wheel hub and bearing assembly |               |

Refer to [GI-4, "Components"](#) for symbols in the figure.

#### Removal and Installation

INFOID:000000003138926

##### REMOVAL

1. Remove tires with power tool.
2. Remove wheel sensor and sensor harness. Refer to [BRC-107, "FRONT WHEEL SENSOR : Exploded View"](#).  
**CAUTION:**  
**Never pull on wheel sensor harness.**
3. Remove brake hose bracket. Refer to [BR-20, "FRONT : Exploded View"](#).
4. Remove caliper assembly with power tool. Hang caliper assembly in a place where it will not interfere with work. Refer to [BR-35, "BRAKE CALIPER ASSEMBLY : Removal and Installation"](#).  
**CAUTION:**  
**Never depress brake pedal while brake caliper is removed.**
5. Remove disc rotor. Refer to [BR-34, "BRAKE CALIPER ASSEMBLY : Exploded View"](#).
6. Remove wheel hub and bearing assembly, and then remove splash guard.
7. Remove steering outer socket. Refer to [ST-25, "2WD : Exploded View"](#).
8. Remove cotter pin of transverse link and steering knuckle, and then loosen nut.
9. Separate steering knuckle from upper link.
10. Separate steering knuckle from transverse link so as not to damage ball joint boot using the ball joint remover, and remove steering knuckle.  
**CAUTION:**  
**Temporarily tighten the nut to prevent damage to threads and to prevent the ball joint remover from suddenly coming off.**

##### INSTALLATION

Note the following, and install in the reverse order of the removal.

- Perform the final tightening of each of parts under unladen conditions, which were removed when removing wheel hub and bearing assembly and steering knuckle.

# FRONT WHEEL HUB AND KNUCKLE

[2WD]

< ON-VEHICLE REPAIR >

- Never reuse cotter pin.

## Inspection

INFOID:000000003138927

A

## INSPECTION AFTER REMOVAL

Check components for deformation, cracks, and other damage. Replace it if necessary.

B

### Ball Joint Inspection

Check boots of transverse link and steering outer socket ball joint for breakage, axial play, and torque. Refer to [FSU-13. "Inspection"](#) and [ST-33. "2WD : Inspection"](#).

C

## INSPECTION AFTER INSTALLATION

1. Check wheel sensor harness for proper connection. Refer to [BRC-107. "FRONT WHEEL SENSOR : Exploded View"](#).
2. Check the wheel alignment. Refer to [FSU-8. "Inspection"](#).
3. Adjust neutral position of steering angle sensor. Refer to [BRC-8. "ADJUSTMENT OF STEERING ANGLE SENSOR NEUTRAL POSITION : Special Repair Requirement"](#).

FAX

E

F

G

H

I

J

K

L

M

N

O

P

# SERVICE DATA AND SPECIFICATIONS (SDS)

< SERVICE DATA AND SPECIFICATIONS (SDS)

[2WD]

## SERVICE DATA AND SPECIFICATIONS (SDS)

### SERVICE DATA AND SPECIFICATIONS (SDS)

#### Wheel Bearing

INFOID:000000003138928

| Item           | Standard                   |
|----------------|----------------------------|
| Axial end play | 0.05 mm (0.002 in) or less |



# NOISE, VIBRATION AND HARSHNESS (NVH) TROUBLESHOOTING

< SYMPTOM DIAGNOSIS >

[AWD]

## SYMPTOM DIAGNOSIS

### NOISE, VIBRATION AND HARSHNESS (NVH) TROUBLESHOOTING

#### NVH Troubleshooting Chart

INFOID:000000003138929

Use chart below to help you find the cause of the symptom. If necessary, repair or replace these parts.

| Reference page                     |             |                               | —                     | <a href="#">FAX-30</a>   | —         | <a href="#">FAX-16</a>           | —                  | <a href="#">FAX-14</a> | NVH in FAX and FSU sections     | Refer to Front axle in this chart. | NVH in WT section | NVH in WT section | Refer to DRIVE SHAFT in this chart. | NVH in BR section | NVH in ST section |   |
|------------------------------------|-------------|-------------------------------|-----------------------|--------------------------|-----------|----------------------------------|--------------------|------------------------|---------------------------------|------------------------------------|-------------------|-------------------|-------------------------------------|-------------------|-------------------|---|
| Possible cause and SUSPECTED PARTS |             |                               | Excessive joint angle | Joint sliding resistance | Imbalance | Improper installation, looseness | Parts interference | Wheel bearing damage   | FRONT AXLE AND FRONT SUSPENSION | FRONT AXLE                         | TIRE              | ROAD WHEEL        | DRIVE SHAFT                         | BRAKE             | STEERING          |   |
| Symptom                            | DRIVE SHAFT | Noise                         | x                     | x                        |           |                                  |                    | x                      | x                               | x                                  | x                 | x                 |                                     | x                 | x                 |   |
|                                    |             | Shake                         | x                     |                          | x         |                                  |                    |                        | x                               | x                                  | x                 | x                 |                                     | x                 | x                 |   |
|                                    | FRONT AXLE  | Noise                         |                       |                          |           | x                                | x                  | x                      | x                               |                                    | x                 | x                 | x                                   | x                 | x                 | x |
|                                    |             | Shake                         |                       |                          |           | x                                | x                  | x                      | x                               |                                    | x                 | x                 | x                                   | x                 | x                 | x |
|                                    |             | Vibration                     |                       |                          |           | x                                | x                  | x                      | x                               |                                    | x                 |                   |                                     | x                 |                   | x |
|                                    |             | Shimmy                        |                       |                          |           | x                                | x                  |                        | x                               |                                    | x                 | x                 |                                     |                   | x                 | x |
|                                    |             | Judder                        |                       |                          |           | x                                |                    |                        | x                               |                                    | x                 | x                 |                                     |                   | x                 | x |
|                                    |             | Poor quality ride or handling |                       |                          |           | x                                | x                  |                        | x                               |                                    | x                 | x                 |                                     |                   |                   |   |

x: Applicable

A  
B  
C  
E  
F  
G  
H  
I  
J  
K  
L  
M  
N  
O  
P

FAX

## PRECAUTION

### PRECAUTIONS

#### Precaution for Supplemental Restraint System (SRS) "AIR BAG" and "SEAT BELT PRE-TENSIONER"

INFOID:000000003138930

The Supplemental Restraint System such as "AIR BAG" and "SEAT BELT PRE-TENSIONER", used along with a front seat belt, helps to reduce the risk or severity of injury to the driver and front passenger for certain types of collision. This system includes seat belt switch inputs and dual stage front air bag modules. The SRS system uses the seat belt switches to determine the front air bag deployment, and may only deploy one front air bag, depending on the severity of a collision and whether the front occupants are belted or unbelted. Information necessary to service the system safely is included in the "SRS AIRBAG" and "SEAT BELT" of this Service Manual.

**WARNING:**

- To avoid rendering the SRS inoperative, which could increase the risk of personal injury or death in the event of a collision which would result in air bag inflation, all maintenance must be performed by an authorized NISSAN/INFINITI dealer.
- Improper maintenance, including incorrect removal and installation of the SRS, can lead to personal injury caused by unintentional activation of the system. For removal of Spiral Cable and Air Bag Module, see the "SRS AIRBAG".
- Do not use electrical test equipment on any circuit related to the SRS unless instructed to in this Service Manual. SRS wiring harnesses can be identified by yellow and/or orange harnesses or harness connectors.

#### Precaution Necessary for Steering Wheel Rotation after Battery Disconnect

INFOID:000000003138931

**NOTE:**

- Before removing and installing any control units, first turn the push-button ignition switch to the LOCK position, then disconnect both battery cables.
- After finishing work, confirm that all control unit connectors are connected properly, then re-connect both battery cables.
- Always use CONSULT-III to perform self-diagnosis as a part of each function inspection after finishing work. If a DTC is detected, perform trouble diagnosis according to self-diagnosis results.

This vehicle is equipped with a push-button ignition switch and a steering lock unit.

If the battery is disconnected or discharged, the steering wheel will lock and cannot be turned.

If turning the steering wheel is required with the battery disconnected or discharged, follow the procedure below before starting the repair operation.

#### OPERATION PROCEDURE

1. Connect both battery cables.
 

**NOTE:**  
Supply power using jumper cables if battery is discharged.
2. Carry the Intelligent Key or insert it to the key slot and turn the push-button ignition switch to ACC position. (At this time, the steering lock will be released.)
3. Disconnect both battery cables. The steering lock will remain released with both battery cables disconnected and the steering wheel can be turned.
4. Perform the necessary repair operation.
5. When the repair work is completed, re-connect both battery cables. With the brake pedal released, turn the push-button ignition switch from ACC position to ON position, then to LOCK position. (The steering wheel will lock when the push-button ignition switch is turned to LOCK position.)
6. Perform self-diagnosis check of all control units using CONSULT-III.

#### Precautions for Drive Shaft

INFOID:000000003138933

**CAUTION:**

Observe the following precautions when disassembling and assembling drive shaft.

- Joint sub-assembly does not disassemble because it is non-overhaul parts.
- Perform work in a location which is as dust-free as possible.

## PRECAUTIONS

< PRECAUTION >

[AWD]

- Before disassembling and assembling, clean the outside of parts.
- Prevention of the entry of foreign objects must be taken into account during disassembly of the service location.
- Disassembled parts must be carefully reassembled in the correct order. If work is interrupted, a clean cover must be placed over parts.
- Paper waste must be used. Fabric shop cloths must not be used because of the danger of lint adhering to parts.
- Disassembled parts (except for rubber parts) should be cleaned with kerosene which shall be removed by blowing with air or wiping with paper waste.

A  
B  
C

FAX

E  
F  
G  
H  
I  
J  
K  
L  
M  
N  
O  
P

# PREPARATION

< PREPARATION >

[AWD]

## PREPARATION

### PREPARATION

#### Special Service Tool

INFOID:000000003138934

The actual shapes of Kent-Moore tools may differ from those of special service tools illustrated here.

| Tool number<br>(Kent-Moore No.)<br>Tool name                                       | Description                 |
|--|-----------------------------|
| KV40107300<br>( - )<br>Boot band crimping tool                                     | Installing boot band        |
| KV40107500<br>( - )<br>Drive shaft attachment                                      | Removing drive shaft        |
| KV38107900<br>( - )<br>Protector<br>a: 32 mm (1.26 in) dia.                        | Installing drive shaft      |
| KV38100500<br>( - )<br>Drift<br>a: 80 mm (3.15 in) dia.<br>b: 60 mm (2.36 in) dia. | Installing drive shaft plug |
| KV38102200<br>( - )<br>Drift<br>a: 90 mm (3.54 in) dia.<br>b: 31 mm (1.22 in) dia. | Installing drive shaft plug |

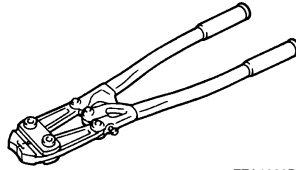

ZZA1229D

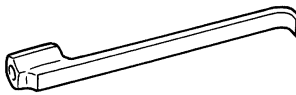

ZZA1230D

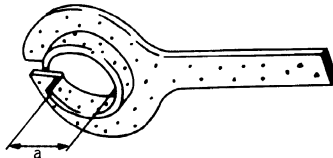

PDIA1183J

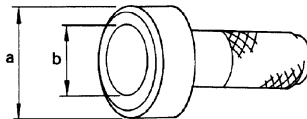

ZZA0701D

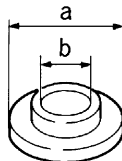

ZZA0920D

# PREPARATION

< PREPARATION >

[AWD]

## Commercial Service Tool

INFOID:000000003138935

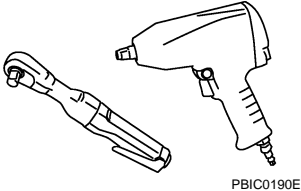
| Tool name  | Description   |
|--|---|
| <p data-bbox="164 287 277 315">Power tool</p>  <p data-bbox="850 506 922 525">PBIC0190E</p> | <p data-bbox="1008 287 1263 317">Loosening bolts and nuts</p> |

A

B

C

FAX

E

F

G

H

I

J

K

L

M

N

O

P

## ON-VEHICLE MAINTENANCE

### FRONT WHEEL HUB AND KNUCKLE

#### Inspection

INFOID:000000003138936

#### MOUNTING INSPECTION

Make sure that the mounting conditions (looseness, backlash) of each component and component conditions (wear, damage) are normal.

#### WHEEL BEARING INSPECTION

- Move wheel hub and bearing assembly in the axial direction by hand. Make sure there is no looseness of wheel bearing.

#### Standard

**Axial end play** : Refer to [FAX-32, "Wheel Bearing"](#).

- Rotate wheel hub and make sure that is no unusual noise or other irregular conditions. If there is any of irregular conditions, replace wheel hub and bearing assembly.

# FRONT DRIVE SHAFT

< ON-VEHICLE MAINTENANCE >

[AWD]

## FRONT DRIVE SHAFT

### Inspection

INFOID:000000003138937

- Check drive shaft mounting point and joint for looseness and other damage.
- Check boot for cracks and other damage.

**CAUTION:**

**Replace entire drive shaft assembly when noise or vibration occur from drive shaft.**

A

B

C

FAX

E

F

G

H

I

J

K

L

M

N

O

P

# FRONT WHEEL HUB AND KNUCKLE

< ON-VEHICLE REPAIR >

[AWD]

## ON-VEHICLE REPAIR

### FRONT WHEEL HUB AND KNUCKLE

#### Exploded View

INFOID:000000003138938

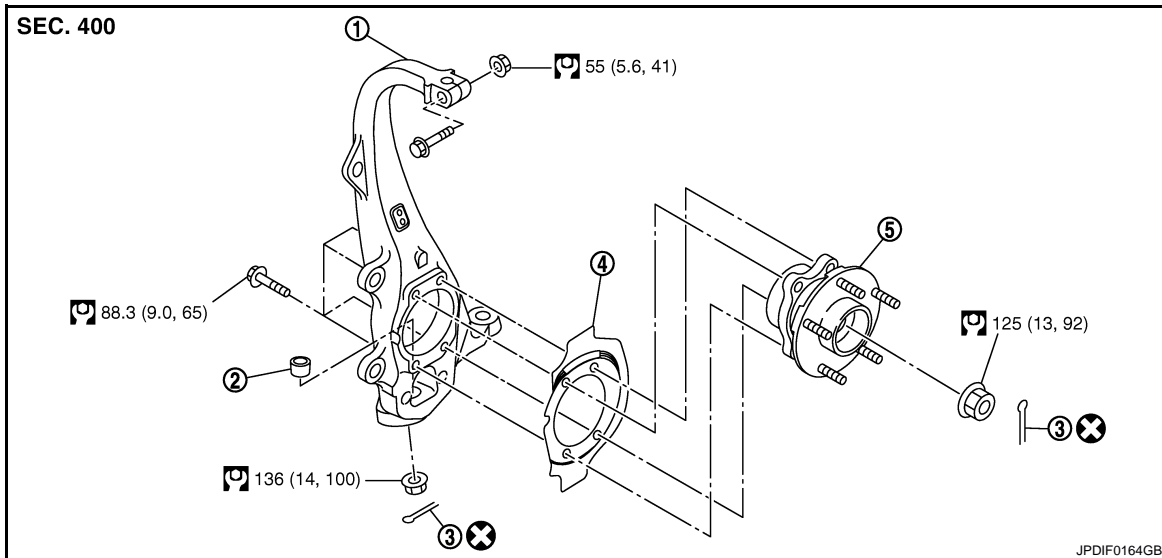

- |                     |                                   |               |
|---------------------|-----------------------------------|---------------|
| 1. Steering knuckle | 2. Ball seat                      | 3. Cotter pin |
| 4. Splash guard     | 5. Wheel hub and bearing assembly |               |

Refer to [GI-4, "Components"](#) for symbols in the figure.

#### Removal and Installation

INFOID:000000003138939

##### REMOVAL

1. Remove tires with power tool.
2. Remove wheel sensor and sensor harness. Refer to [BRC-107, "FRONT WHEEL SENSOR : Exploded View"](#).  
**CAUTION:**  
**Never pull on wheel sensor harness.**
3. Remove brake hose bracket. Refer to [BR-20, "FRONT : Exploded View"](#).
4. Remove caliper assembly mounting bolts with power tool. Hang caliper assembly in a place where it will not interfere with work. Refer to [BR-34, "BRAKE CALIPER ASSEMBLY : Exploded View"](#).  
**CAUTION:**  
**Never depress brake pedal while brake caliper is removed.**
5. Remove disc rotor. Refer to [BR-35, "BRAKE CALIPER ASSEMBLY : Removal and Installation"](#).
6. Remove cotter pin, and then loosen hub lock nut with power tool.
7. Patch hub lock nut with a piece of wood. Hammer the wood to disengage wheel hub and bearing assembly from drive shaft.  
**CAUTION:**
  - Never place drive shaft joint at an extreme angle. Also be careful not to overextend slide joint.
  - Never allow drive shaft to hang down without support for or joint sub-assembly, shaft and the other parts.**NOTE:**  
Use suitable puller, if wheel hub and bearing assembly and drive shaft cannot be separated even after performing the above procedure.
8. Remove wheel hub lock nut.
9. Remove wheel hub and bearing assembly, and then remove splash guard.

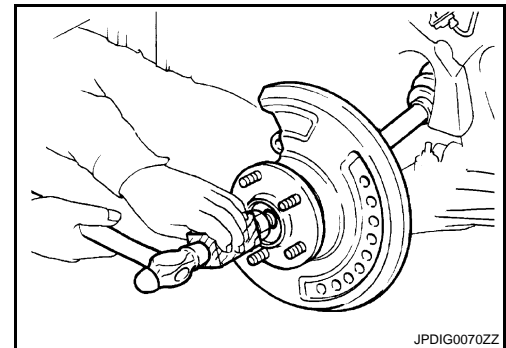



# FRONT WHEEL HUB AND KNUCKLE

[AWD]

< ON-VEHICLE REPAIR >

10. Remove steering outer socket. Refer to [ST-34, "AWD : Exploded View"](#).
11. Remove cotter pin of transverse link and steering knuckle, and then loosen nut.
12. Separate steering knuckle from upper link.
13. Separate steering knuckle link from transverse so as not to damage ball joint boot using the ball joint remover, and remove steering knuckle.

**CAUTION:**

**Temporarily tighten the nut to prevent damage to threads and to prevent the ball joint remover from suddenly coming off.**

## INSTALLATION

Note the following, and install in the reverse order of the removal.

- Perform the final tightening of each of parts under unladen conditions, which were removed when removing wheel hub and bearing assembly and steering knuckle.
- Never reuse cotter pin.

## Inspection

INFOID:000000003138940

## INSPECTION AFTER REMOVAL

Check components for deformation, cracks, and other damage. Replace it if necessary.

### Ball Joint Inspection

Check boots of transverse link and steering outer socket ball joint for breakage, axial play, and torque. Refer to [FSU-32, "Inspection"](#) and [ST-43, "AWD : Inspection"](#).

## INSPECTION AFTER INSTALLATION

1. Check wheel sensor harness for proper connection. Refer to [BRC-107, "FRONT WHEEL SENSOR : Exploded View"](#).
2. Check the wheel alignment. Refer to [FSU-8, "Inspection"](#).
3. Adjust neutral position of steering angle sensor. Refer to [BRC-8, "ADJUSTMENT OF STEERING ANGLE SENSOR NEUTRAL POSITION : Special Repair Requirement"](#).

# FRONT DRIVE SHAFT BOOT

< ON-VEHICLE REPAIR >

[AWD]

## FRONT DRIVE SHAFT BOOT

Exploded View

INFOID:000000003138941

LEFT SIDE

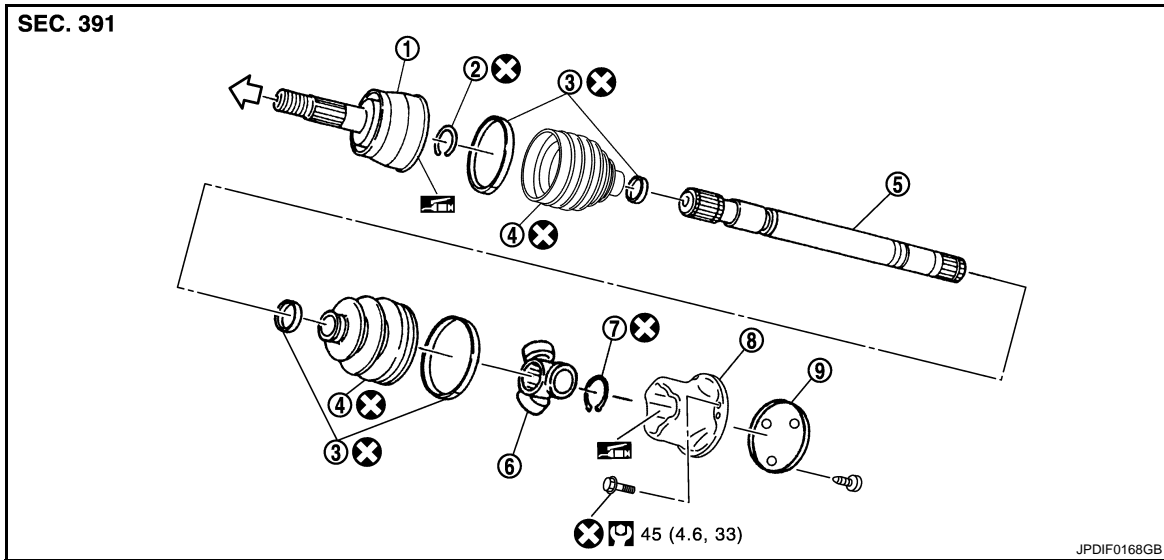

- |                       |                  |                    |
|-----------------------|------------------|--------------------|
| 1. Joint sub-assembly | 2. Circular clip | 3. Boot band       |
| 4. Boot               | 5. Shaft         | 6. Spider assembly |
| 7. Snap ring          | 8. Housing       | 9. Plug            |

⇐: Wheel side

: NISSAN genuine grease or an equivalent.

Refer to [GI-4, "Components"](#) for symbols not described on the above.

RIGHT SIDE

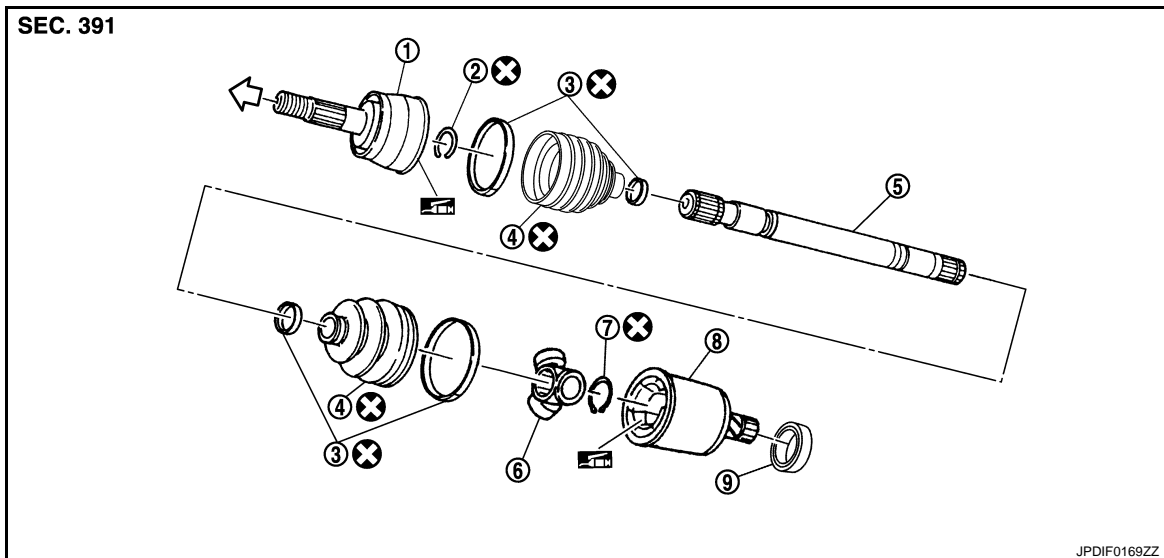

- |                       |                  |                    |
|-----------------------|------------------|--------------------|
| 1. Joint sub-assembly | 2. Circular clip | 3. Boot band       |
| 4. Boot               | 5. Shaft         | 6. Spider assembly |
| 7. Snap ring          | 8. Housing       | 9. Dust shield     |

⇐: Wheel side

# FRONT DRIVE SHAFT BOOT

< ON-VEHICLE REPAIR >

[AWD]

 NISSAN genuine grease or an equivalent.

Refer to [GI-4, "Components"](#) for symbols not described on the above.

## WHEEL SIDE

### WHEEL SIDE : Removal and Installation

INFOID:000000003573811

#### REMOVAL

1. Remove tires with power tool.
2. Remove wheel sensor and sensor harness. Refer to [BRC-107, "FRONT WHEEL SENSOR : Exploded View"](#).

**CAUTION:**

**Never pull on wheel sensor harness.**

3. Remove brake hose bracket. Refer to [BR-20, "FRONT : Exploded View"](#).
4. Remove caliper assembly mounting bolts with power tool. Hang caliper assembly in a place where it will not interfere with work. Refer to [BR-34, "BRAKE CALIPER ASSEMBLY : Exploded View"](#).

**CAUTION:**

**Never depress brake pedal while brake caliper is removed.**

5. Remove disc rotor. Refer to [BR-35, "BRAKE CALIPER ASSEMBLY : Removal and Installation"](#).

6. Remove cotter pin, and then loosen hub lock nut with a power tool. Refer to [FAX-16, "Exploded View"](#).

7. Patch hub lock nut with a piece of wood. Hammer the wood to disengage wheel hub and bearing assembly from drive shaft.

**CAUTION:**

- **Never place drive shaft joint at an extreme angle. Also be careful not to overextend slide joint.**
- **Never allow drive shaft to hang down without support for joint sub-assembly, shaft and the other parts.**

**NOTE:**

Use suitable puller if wheel hub and bearing assembly and drive shaft cannot be separated even after performing the above procedure.

8. Remove wheel hub lock nut.
9. Remove steering outer socket. Refer to [ST-34, "AWD : Exploded View"](#).
10. Remove cotter pin of transverse link and steering knuckle, and then loosen nut. Refer to [FAX-16, "Exploded View"](#).

11. Separate steering knuckle from transverse link so as not to damage ball joint boot using the ball joint remover.

**CAUTION:**

**Temporarily tighten the nut to prevent damage to threads and to prevent the ball joint remover from suddenly coming off.**

12. Remove drive shaft from wheel hub and bearing assembly.
13. Remove boot bands, and then remove boot from joint sub-assembly.

14. Screw drive shaft puller (A) 30 mm (1.18 in) or more into the thread of joint sub-assembly, and pull joint sub-assembly with a sliding hammer (B) from shaft.

**CAUTION:**

- **Align a sliding hammer and drive shaft and remove them by pulling firmly and uniformly.**
- **If joint sub-assembly cannot be pulled out, try after removing drive shaft from vehicle.**

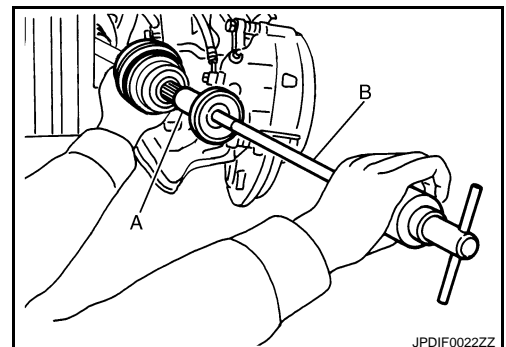
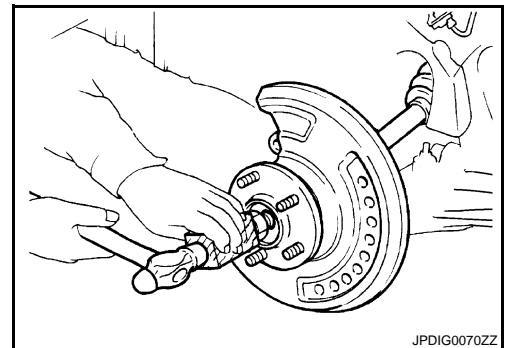

# FRONT DRIVE SHAFT BOOT

[AWD]

## < ON-VEHICLE REPAIR >

15. Remove circular clip (1) from shaft.
16. Remove boot from shaft.

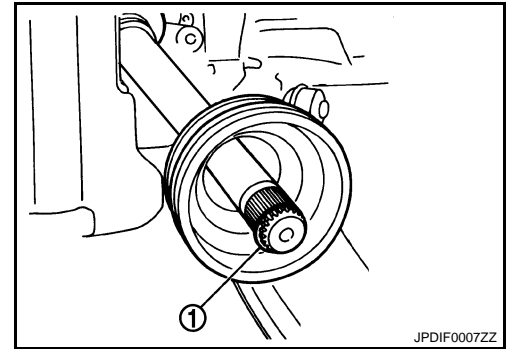

## INSTALLATION

1. Clean the old grease on joint sub-assembly with paper waste.
2. Fill serration slot joint sub-assembly (1) with NISSAN genuine grease or equivalent until the serration slot and ball groove become full to the brim.

**CAUTION:**

After applying grease, use a shop cloth to wipe off old grease that has oozed out.

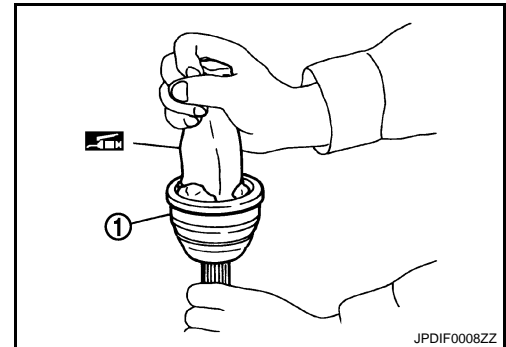

3. Wrap serration on shaft with tape (A) to protect the boot from damage. Install boot and boot bands to shaft.

**CAUTION:**

Never reuse boot and boot band.

4. Remove the tape wrapped around the serration on shaft.

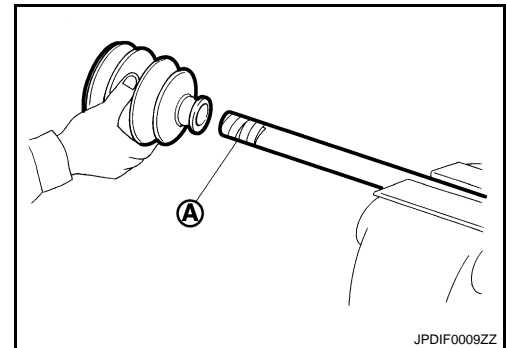

5. Position circular clip (1) on groove at the shaft edge.

**CAUTION:**

Never reuse circular clip.

**NOTE:**

Drive joint inserter is recommended when installing circular clip.

6. Align both center axes of the shaft edge and joint sub-assembly. Then assemble shaft with circular clip joint sub-assembly.

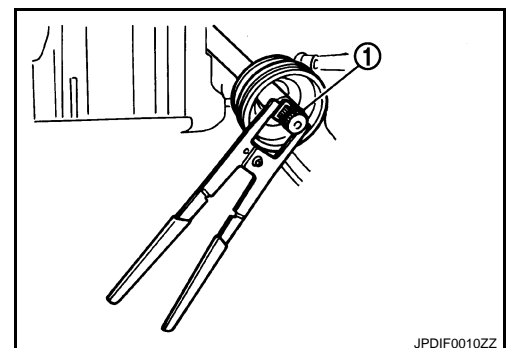

# FRONT DRIVE SHAFT BOOT

[AWD]

< ON-VEHICLE REPAIR >

7. Install joint sub-assembly (1) to shaft using plastic hammer.

**CAUTION:**

**Confirm that joint sub-assembly is correctly engaged while rotating drive shaft.**

8. Fill serration slot joint sub-assembly with NISSAN genuine grease or equivalent until the serration slot and ball groove become full to the brim.

**Standard**

**Grease amount** : Refer to [FAX-32, "Drive Shaft"](#).

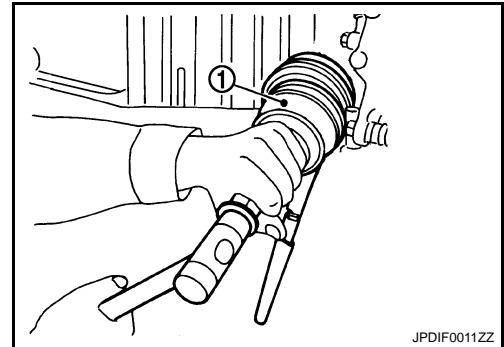

9. Install the boot securely into grooves (indicated by "\*" marks) shown in the figure.

**CAUTION:**

**If grease adheres to the boot mounting surface (indicated by "\*" mark) on the shaft or joint sub-assembly, boot may come off. Remove all grease from the surface.**

10. To prevent from the deformation of the boot, adjust the boot installation length (L) to the specified value shown below by inserting the suitable tool into inside of the boot from the large diameter side of the boot and discharging the inside air.

**Standard**

**L** : Refer to [FAX-32, "Drive Shaft"](#).

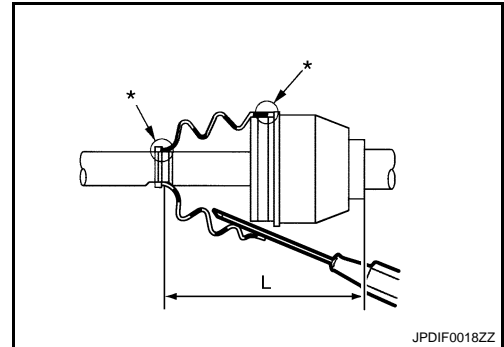

**CAUTION:**

- If the boot mounting length is outside the standard, it may cause breakage in the boot.
- Be careful not to touch the inside of the boot with a tip of tool.

11. Secure the ends of the boot with boot bands using the boot band crimping tool (A) [SST: KV40107300 ( - )].

**CAUTION:**

**Never reuse boot band.**

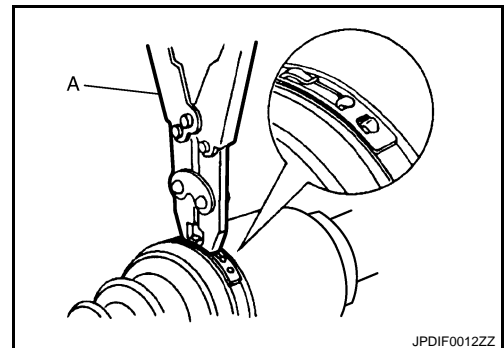

**NOTE:**

Secure boot band so that dimension (M) meets the specification as shown in the figure.

**M** : 2.0 – 3.0 mm (0.079 – 0.118 in)

12. Secure joint sub-assembly and shaft, and then make sure that they are in the correct position when rotating boot. Install them with boot band when boot installation positions become incorrect.

**CAUTION:**

**Never reuse boot band.**

13. Insert drive shaft to wheel hub and bearing assembly, and then temporarily tighten hub lock nut.

**CAUTION:**

- The drive shaft is press-fit. When assembling the shaft, never press it, but pull it until fully seated by tightening the hub lock nut.

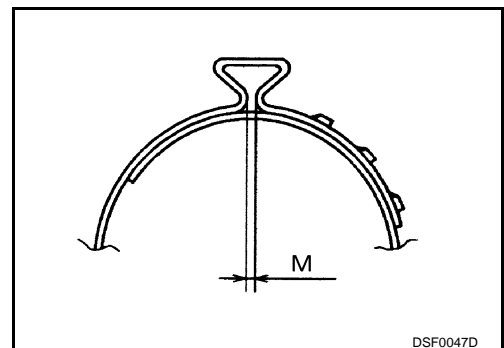

# FRONT DRIVE SHAFT BOOT

< ON-VEHICLE REPAIR >

[AWD]

- Check that anticorrosive oil is applied to the thread of the drive shaft. If not, apply appropriate oil such as engine oil.
  - If sufficient oil is not applied to the thread of the drive shaft, the hub lock nut may be seized and the tightening torque reaches the specified limit prematurely. It may cause looseness or abnormal noises.
14. Install steering knuckle. Refer to [FAX-16, "Exploded View"](#).
  15. Install steering outer socket to steering knuckle. Refer to [ST-34, "AWD : Exploded View"](#).
  16. Tighten the hub lock nut to the specified torque, and install cotter pin. Refer to [FAX-16, "Exploded View"](#).  
**CAUTION:**
    - Never reuse cotter pin.
    - Bend it at the root sufficiently to prevent any looseness.
  17. Install disc rotor. Refer to [BR-35, "BRAKE CALIPER ASSEMBLY : Removal and Installation"](#).
  18. Install caliper assembly to steering knuckle. Refer to [BR-34, "BRAKE CALIPER ASSEMBLY : Exploded View"](#).
  19. Install brake hose bracket to steering knuckle. Refer to [BR-20, "FRONT : Exploded View"](#).
  20. Install wheel sensor to steering knuckle. Refer to [BRC-107, "FRONT WHEEL SENSOR : Exploded View"](#).

## FINAL DRIVE SIDE

### FINAL DRIVE SIDE : Removal and Installation

INFOID:000000003573812

#### NOTE:

Remove boot after removing drive shaft. Refer to [FAX-24, "LEFT SIDE : Removal and Installation"](#) (left side), [FAX-24, "RIGHT SIDE : Removal and Installation"](#) (right side).

### Inspection

INFOID:000000003573826

#### INSPECTION AFTER REMOVAL

- Move joint up/down, left/right, and in the axial directions. Check for motion that is not smooth and for significant looseness.
- Check boot for cracks, damage, and leakage of grease.
- Disassemble drive shaft and exchange malfunctioning part if there is a non-standard condition.

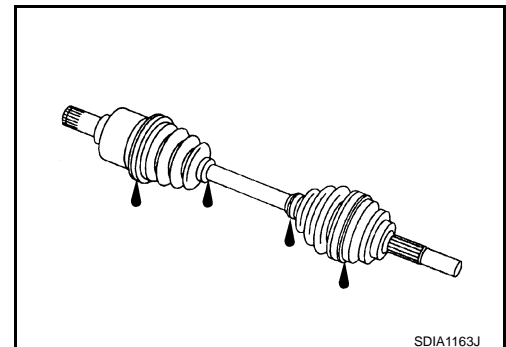

# FRONT DRIVE SHAFT

< ON-VEHICLE REPAIR >

[AWD]

## FRONT DRIVE SHAFT

Exploded View

INFOID:000000003138943

LEFT SIDE

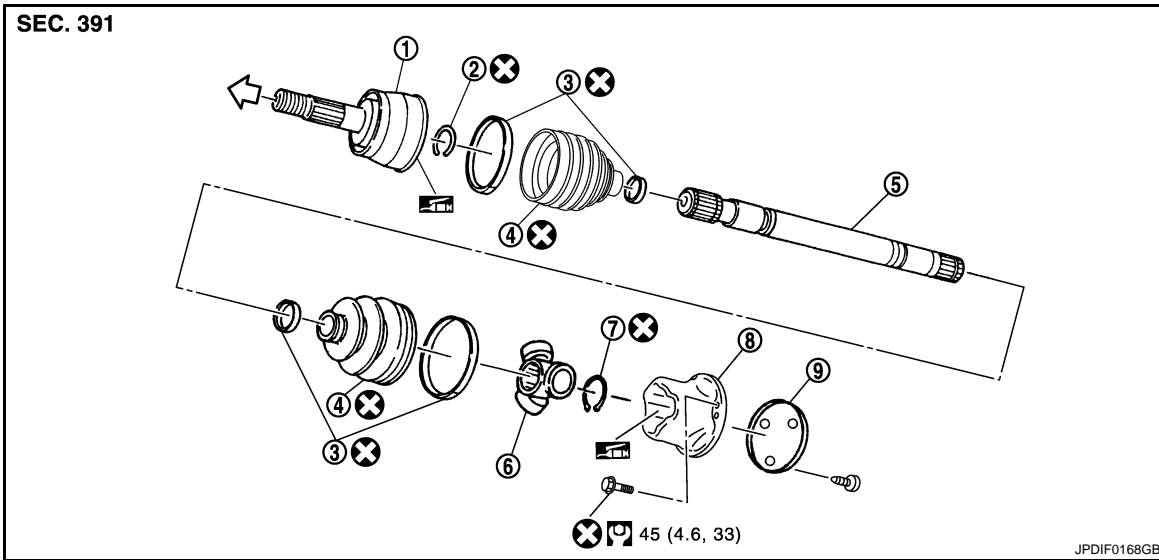

- |                       |                  |                    |
|-----------------------|------------------|--------------------|
| 1. Joint sub-assembly | 2. Circular clip | 3. Boot band       |
| 4. Boot               | 5. Shaft         | 6. Spider assembly |
| 7. Snap ring          | 8. Housing       | 9. Plug            |

⇐ Wheel side

: NISSAN genuine grease or an equivalent.

Refer to [GI-4. "Components"](#) for symbols not described on the above.

RIGHT SIDE

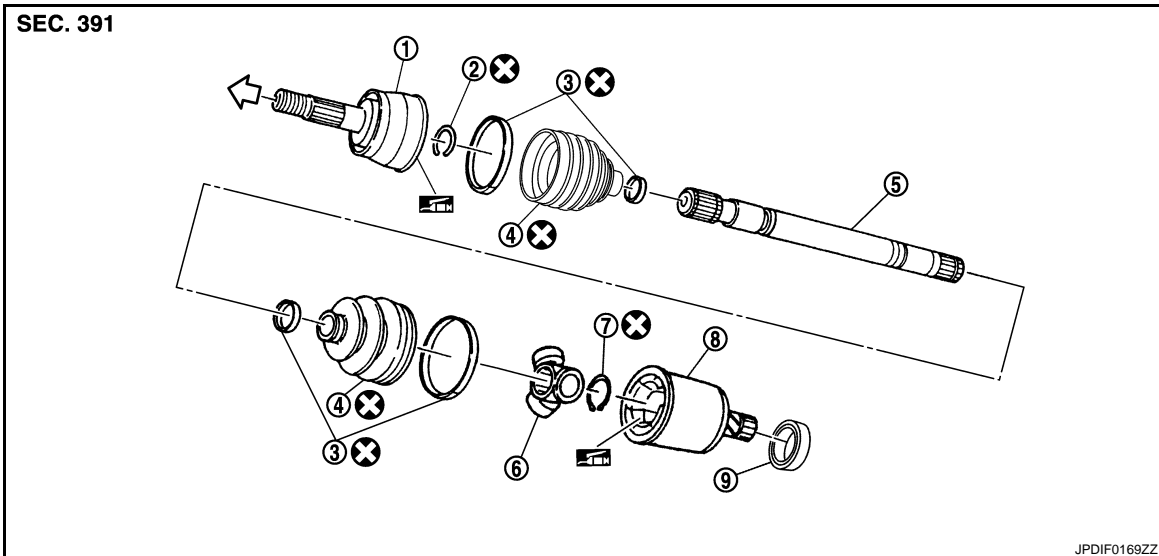

- |                       |                  |                    |
|-----------------------|------------------|--------------------|
| 1. Joint sub-assembly | 2. Circular clip | 3. Boot band       |
| 4. Boot               | 5. Shaft         | 6. Spider assembly |
| 7. Snap ring          | 8. Housing       | 9. Dust shield     |

⇐ Wheel side

A  
B  
C  
FAX  
E  
F  
G  
H  
I  
J  
K  
L  
M  
N  
O  
P

# FRONT DRIVE SHAFT

< ON-VEHICLE REPAIR >

[AWD]

 NISSAN genuine grease or an equivalent.

Refer to [GI-4, "Components"](#) for symbols not described on the above.

## LEFT SIDE

### LEFT SIDE : Removal and Installation

INFOID:000000003138944

#### REMOVAL

1. Remove tires with power tool.
2. Remove wheel sensor and sensor harness. Refer to [BRC-107, "FRONT WHEEL SENSOR : Exploded View"](#).  
**CAUTION:**  
**Never pull on wheel sensor harness.**
3. Remove brake hose bracket. Refer to [BR-20, "FRONT : Exploded View"](#).
4. Remove caliper assembly mounting bolts with power tool. Hang caliper assembly in a place where it will not interfere with work. Refer to [BR-34, "BRAKE CALIPER ASSEMBLY : Exploded View"](#).  
**CAUTION:**  
**Never depress brake pedal while brake caliper is removed.**
5. Remove disc rotor. Refer to [BR-35, "BRAKE CALIPER ASSEMBLY : Removal and Installation"](#).
6. Remove cotter pin, and then loosen hub lock nut with a power tool. Refer to [FAX-16, "Exploded View"](#).
7. Patch hub lock nut with a piece of wood. Hammer the wood to disengage wheel hub and bearing assembly from drive shaft.  
**CAUTION:**
  - **Never place drive shaft joint at an extreme angle. Also be careful not to overextend slide joint.**
  - **Never allow drive shaft to hang down without support for joint sub-assembly, shaft and the other parts.****NOTE:**  
Use suitable puller if wheel hub and drive shaft cannot be separated even after performing the above procedure.
8. Remove wheel hub lock nut.
9. Remove steering outer socket. Refer to [ST-34, "AWD : Exploded View"](#).
10. Separate upper link from steering knuckle. Refer to [FAX-16, "Exploded View"](#).
11. Remove drive shaft from wheel hub and bearing assembly.
12. Remove shock absorber from vehicle with power tool. Refer to [FSU-28, "Exploded View"](#).
13. Remove mounting bolts, and then remove drive shaft from vehicle.

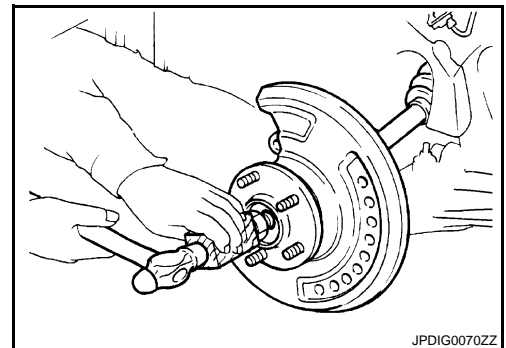

#### INSTALLATION

Install in the reverse order of removal.

## RIGHT SIDE

### RIGHT SIDE : Removal and Installation

INFOID:000000003759868

#### REMOVAL

1. Remove tires with power tool.
2. Remove wheel sensor and sensor harness. Refer to [BRC-107, "FRONT WHEEL SENSOR : Exploded View"](#).  
**CAUTION:**  
**Never pull on wheel sensor harness.**
3. Remove brake hose bracket. Refer to [BR-20, "FRONT : Exploded View"](#).
4. Remove caliper assembly mounting bolts with power tool. Hang caliper assembly in a place where it will not interfere with work. Refer to [BR-34, "BRAKE CALIPER ASSEMBLY : Exploded View"](#).  
**CAUTION:**  
**Never depress brake pedal while brake caliper is removed.**



# FRONT DRIVE SHAFT

[AWD]

## < ON-VEHICLE REPAIR >

- Remove disc rotor. Refer to [BR-35, "BRAKE CALIPER ASSEMBLY : Removal and Installation"](#).
- Remove cotter pin, and then loosen hub lock nut with a power tool.
- Patch hub lock nut with a piece of wood. Hammer the wood to disengage wheel hub and bearing assembly from drive shaft.  
**CAUTION:**
  - Never place drive shaft joint at an extreme angle. Also be careful not to overextend slide joint.
  - Never allow drive shaft to hang down without support for joint sub-assembly, shaft and the other parts.

### NOTE:

Use suitable puller if wheel hub and drive shaft cannot be separated even after performing the above procedure.

- Remove wheel hub lock nut.
- Remove steering outer socket. Refer to [ST-34, "AWD : Exploded View"](#).
- Separate upper link from vehicle. Refer to [FAX-16, "Exploded View"](#).
- Remove drive shaft from wheel hub and bearing assembly.
- Remove shock absorber from transverse link with power tool. Refer to [FSU-28, "Exploded View"](#).

- Remove drive shaft from front final drive using the drive shaft attachment (A) [SST:KV40107500 ( - )] and a sliding hammer (B) while inserting tip of the drive shaft attachment between housing and front final drive.

### CAUTION:

Never place drive shaft joint at an extreme angle when removing drive shaft. Also be careful not to overextend slide joint.

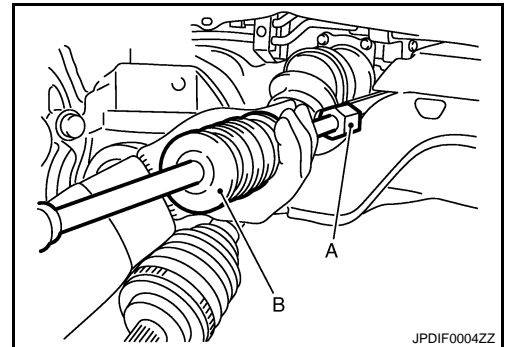
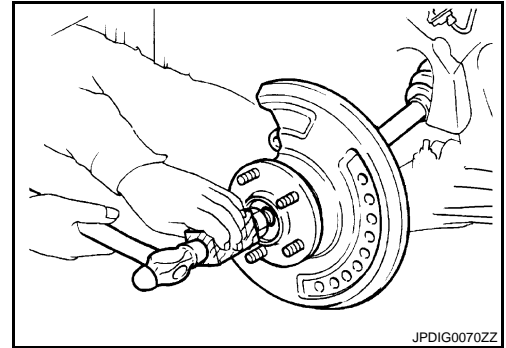

## INSTALLATION

Note the following, and install in the reverse order of removal.

### CAUTION:

Always replace final drive oil seal with new one when installing drive shaft. Refer to [DLN-45, "Exploded View"](#).

- Place the protector (A) [SST:KV38107900 ( - )] onto final drive to prevent damage to the oil seal while inserting drive shaft. Slide drive shaft sliding joint and tap with a hammer to install securely.

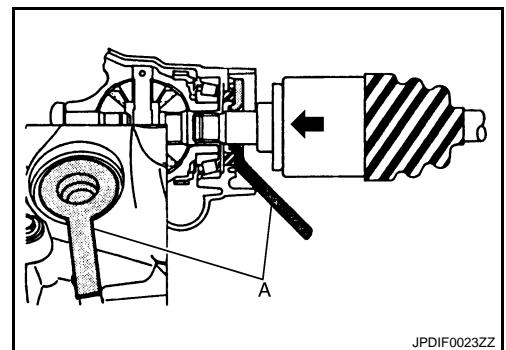

## WHEEL SIDE

### WHEEL SIDE : Disassembly and Assembly

INFOID:000000003573813

#### DISASSEMBLY

- Fix shaft with a vise.  
**CAUTION:**  
Protect shaft when fixing with a vise using aluminum or copper plates.
- Remove boot bands, and then remove boot from joint sub-assembly.

A  
B  
C  
FAX  
E  
F  
G  
H  
I  
J  
K  
L  
M  
N  
O  
P

# FRONT DRIVE SHAFT

[AWD]

## < ON-VEHICLE REPAIR >

3. Screw drive shaft puller (A) 30 mm (1.18 in) or more into the thread of joint sub-assembly, and pull joint sub-assembly with a sliding hammer (B) from shaft.

**CAUTION:**

- If joint sub-assembly cannot be removed after five or more unsuccessful attempts, replace shaft and joint sub-assembly as a set.
- Align sliding hammer and drive shaft and remove them by pulling directory.

4. Remove circular clip from shaft.
5. Remove boot from shaft.
6. Clean old grease on joint sub-assembly with paper waste while rotating ball cage.

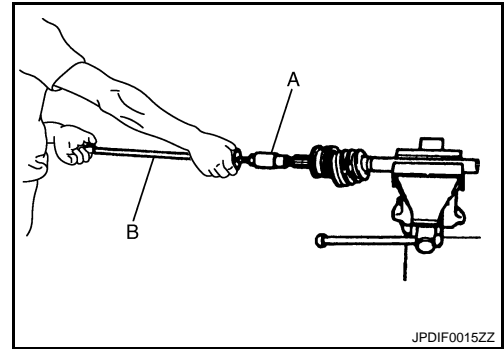

## ASSEMBLY

1. Clean the old grease on joint sub-assembly with paper waste.
2. Fill serration slot joint sub-assembly (1) with NISSAN genuine grease or equivalent until the serration slot and ball groove become full to the brim.

**CAUTION:**

After applying grease, use a shop cloth to wipe off old grease that has oozed out.

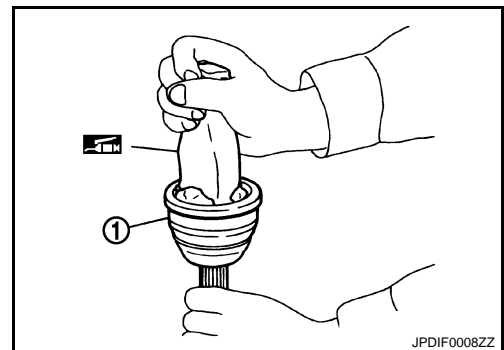

3. Wrap serration on shaft with tape (A) to protect the boot from damage. Install boot and boot bands to shaft.

**CAUTION:**

Never reuse boot and boot band.

4. Remove the tape wrapped around the serration on shaft.
5. Position circular clip on groove at the shaft edge.

**CAUTION:**

Never reuse circular clip.

**NOTE:**

Drive joint inserter is recommended when installing circular clip.

6. Align both center axles of the shaft edge and joint sub-assembly. Then assemble shaft with circular clip joint sub-assembly.

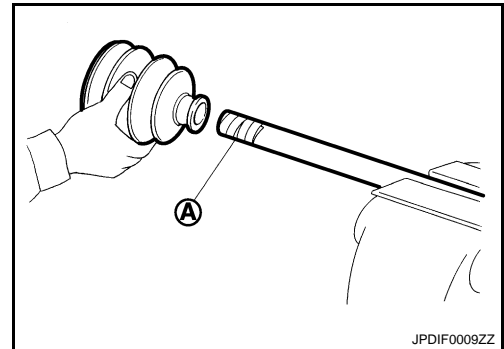

7. Install joint sub-assembly (1) to shaft using plastic hammer.

**CAUTION:**

Confirm that joint sub-assembly is correctly engaged while rotating drive shaft.

8. Apply the balance of the specified amount of grease into the boot inside from large diameter side of boot.

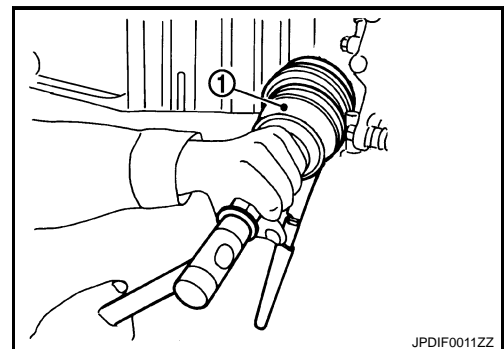

**Standard**

**Grease amount** : Refer to [FAX-32, "Drive Shaft"](#).

# FRONT DRIVE SHAFT

[AWD]

## < ON-VEHICLE REPAIR >

9. Install the boot securely into grooves (indicated by "\*" marks) shown in the figure.

**CAUTION:**

If grease adheres to the boot mounting surface (indicated by "\*" mark) on the shaft or joint sub-assembly, boot may come off. Remove all grease from the surface.

10. To prevent from the deformation of the boot, adjust the boot installation length (L) to the specified value shown below by inserting the suitable tool into inside of the boot from the large diameter side of the boot and discharging the inside air.

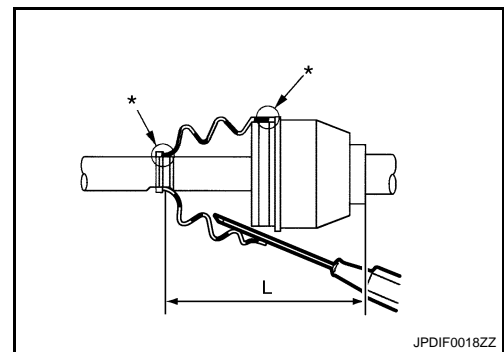

**Standard**

**L**

: Refer to [FAX-32, "Drive Shaft"](#).

**CAUTION:**

- If the boot mounting length is outside the standard, it may cause breakage in the boot.
- Be careful not to touch the inside of the boot with a tip of tool.

11. Secure the ends of the boot with boot bands using the boot band crimping tool (A) [SST: KV40107300 ( - )].

**CAUTION:**

Never reuse boot band.

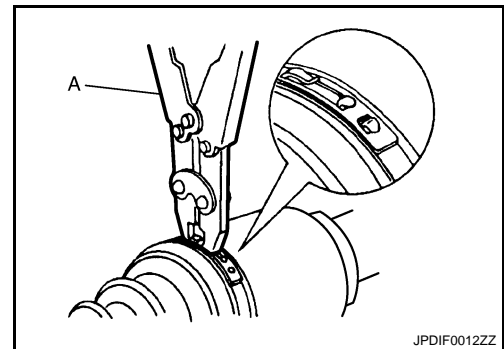

**NOTE:**

Secure boot band so that dimension (M) meets the specification as shown in the figure.

**M**

: 2.0 – 3.0 mm (0.079 – 0.118 in)

12. Secure joint sub-assembly and shaft, and then make sure that they are in the correct position when rotating boot. Install them with boot band when boot installation positions become incorrect.

**CAUTION:**

Never reuse boot band.

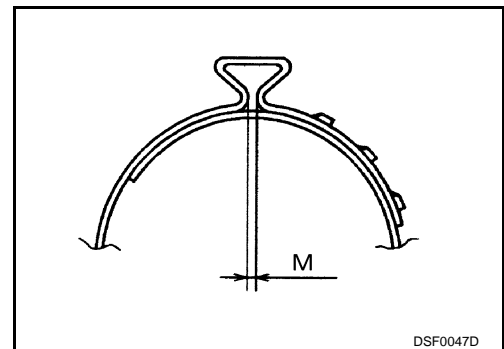

## FINAL DRIVE SIDE

### FINAL DRIVE SIDE : Disassembly and Assembly

INFOID:000000003573814

#### DISASSEMBLY

1. Fix shaft with a vise.

**CAUTION:**

Protect shaft when fixing with a vise using aluminum or copper plates.

2. Remove boot bands, and then remove boot from housing.  
3. If plug needs to be removed, move boot to wheel side, and take it out with a plastic hammer. (Left side)  
4. Put matching marks on housing and shaft, and then pull out housing from shaft.

**CAUTION:**

Use paint or similar substance for matching marks. Never scratch the surfaces.

# FRONT DRIVE SHAFT

[AWD]

## < ON-VEHICLE REPAIR >

- Put matching marks (A) on the spider assembly and shaft.

**CAUTION:**

**Use paint or similar substance for matching marks. Never scratch the surfaces.**

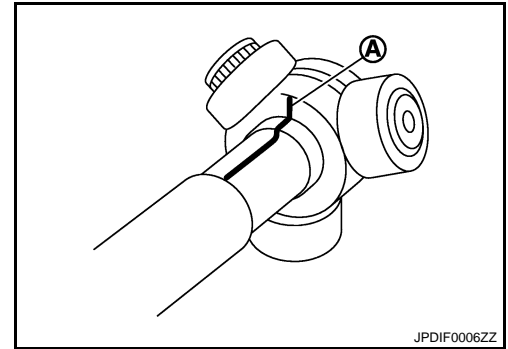

- Remove snap ring (1), and then remove spider assembly from the shaft.
- Remove boot from the shaft.
- Remove plug from housing. (Left side)
- Remove dust shield from housing. (Right side)

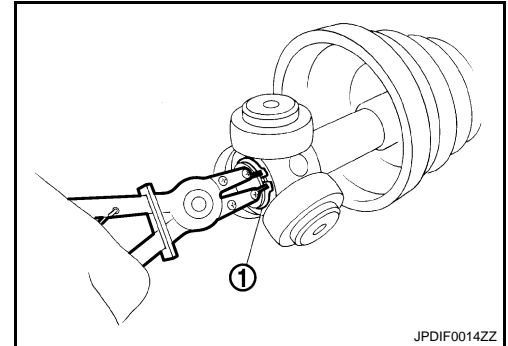

## ASSEMBLY

- Clean old grease on housing with paper waste.
- Plug (1) has been removed. Install a plug to housing (2) with a screw. (Left side)
- Install dust shield to housing. (Right side)

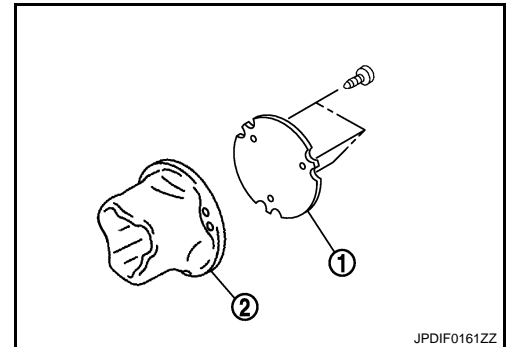

- Wrap serration on shaft with tape (A) to protect boot from damage. Install boot and boot bands to shaft.  
**CAUTION:**  
**Never reuse boot and boot band.**
- Remove the tape wrapped around the serration on shaft.

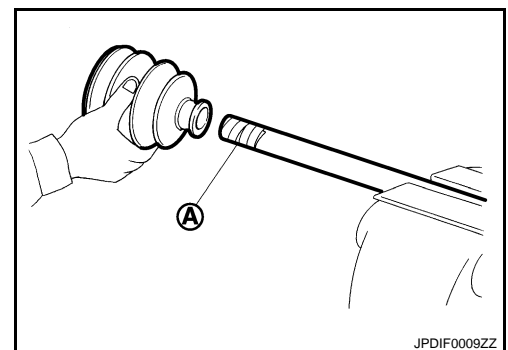

# FRONT DRIVE SHAFT

[AWD]

## < ON-VEHICLE REPAIR >

6. Install the spider assembly (1), align it with the matching marks (A) on the shaft (2) during the removal, and direct the serration mounting surface (B) to the shaft.

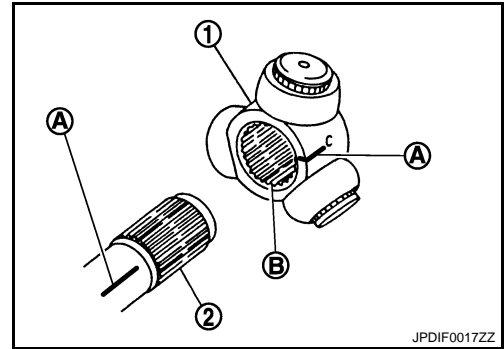

7. Secure spider assembly onto shaft with snap ring (1).  
**CAUTION:**  
**Never reuse snap ring.**
8. Apply the appropriate amount of grease to spider assembly and sliding surface.
9. Assemble the housing onto spider assembly, and apply the balance of the specified amount grease.

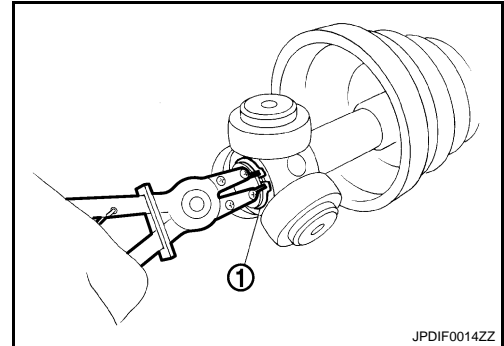

### Standard

Grease amount : Refer to [FAX-32, "Drive Shaft"](#).

10. Align matching marks painted when housing was removed.
11. Install the boot securely into grooves (indicated by "\*" marks) shown in the figure.

### CAUTION:

If grease adheres to the boot mounting surface (indicated by "\*" mark) on shaft or housing, boot may come off. Remove all grease from the surface.

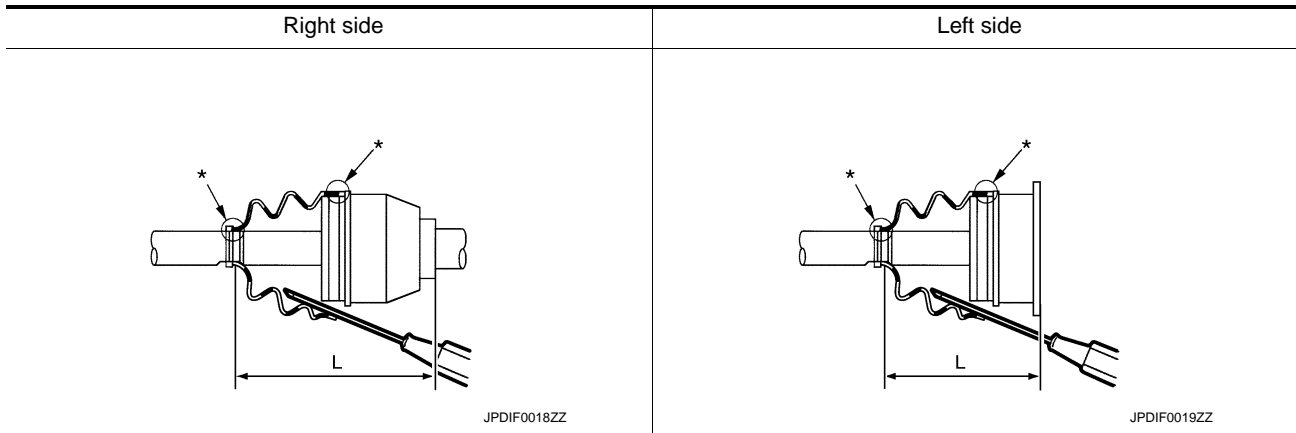

12. To prevent from deformation of the boot, adjust the boot installation length (L) to the value shown below by inserting the suitable tool into the inside of boot from the large diameter side of boot and discharging inside air.

### Standard

L : Refer to [FAX-32, "Drive Shaft"](#).

### CAUTION:

- If the boot installation length is outside the standard, it may cause breakage in boot.
- Be careful not to touch the inside of the boot with the tip of tool.

13. Install boot bands securely.

### CAUTION:

Never reuse boot band.

# FRONT DRIVE SHAFT

[AWD]

## < ON-VEHICLE REPAIR >

- a. For one-touch clamp band (left side)
  - i. Install boot bands securely as shown in the figure.

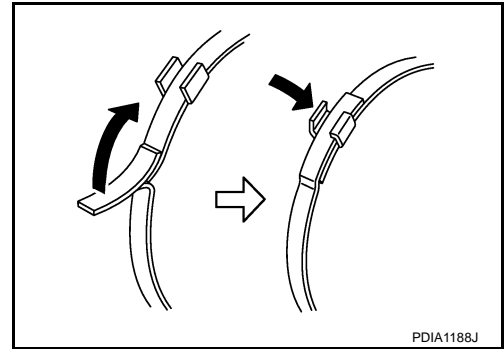

- b. For low profile type band (right side)
  - i. Put boot band in the groove on drive shaft boot. Then fit pawls (←) into holes to temporary installation.  
**NOTE:**  
For the large diameter side, fit projection (A) and guide slit (B) at first.

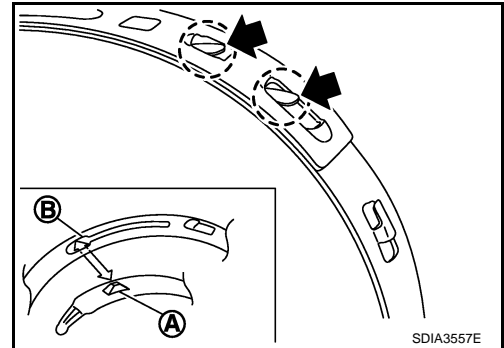

- ii. Pinch projection on the band with suitable pliers to tighten band.
  - iii. Insert tip of band below end of the pawl.
14. Secure housing and shaft, and then make sure that they are in the correct position when rotating boot. Install them with boot band when the mounting positions become incorrect.
15. Install dust cover to housing. (right side)

**CAUTION:**

**Never reuse dust cover.**

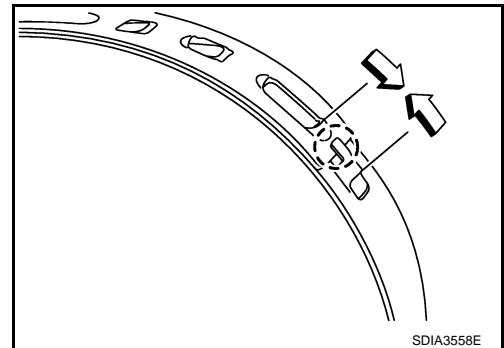

## Inspection

INFOID:000000003138946

### INSPECTION AFTER REMOVAL

- Move joint up/down, left/right, and in the axial directions. Check for motion that is not smooth and for significant looseness.
- Check boot for cracks, damage, and leakage of grease.
- Disassemble drive shaft and exchange malfunctioning part if there is a non-standard condition.

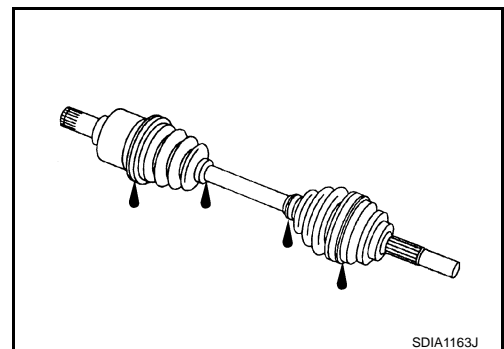

### INSPECTION AFTER DISASSEMBLY

#### Shaft

Check shaft for runout, cracks, or other damage. Replace it if necessary.

#### Joint Sub-Assembly (Wheel Side)

# FRONT DRIVE SHAFT

[AWD]

< ON-VEHICLE REPAIR >

Check the following items, replace the parts if necessary.

- Joint sub-assembly for rough rotation and excessive axial looseness.
  - The inside of the joint sub-assembly for entry of foreign material.
  - Joint sub-assembly for compression scars, cracks, and fractures inside of joint sub-assembly.
- Replace joint sub-assembly if there are any non-standard conditions of components.

Housing and Spider assembly (Final Drive side)

Replace housing and spider assembly if there is scratching or wear of housing roller contact surface or spider roller contact surface.

**NOTE:**

Housing and spider assembly are used in a set.

A

B

C

FAX

E

F

G

H

I

J

K

L

M

N

O

P

## SERVICE DATA AND SPECIFICATIONS (SDS)

< SERVICE DATA AND SPECIFICATIONS (SDS)

[AWD]

# SERVICE DATA AND SPECIFICATIONS (SDS)

## SERVICE DATA AND SPECIFICATIONS (SDS)

### Wheel Bearing

INFOID:000000003138947

| Item           | Standard                   |
|----------------|----------------------------|
| Axial end play | 0.05 mm (0.002 in) or less |

### Drive Shaft

INFOID:000000003138948

| Item                   | Left side        | Right side                  |
|------------------------|------------------|-----------------------------|
| Grease quantity        | Wheel side       | 77 – 97 g (2.72 – 3.42 oz)  |
|                        | Final drive side | 95 – 105 g (3.36 – 3.70 oz) |
| Boots installed length | Wheel side       | 136 mm (5.35 in)            |
|                        | Final drive side | 152 mm (5.98 in)            |