

SECTION **DEF**
DEFOGGER

A
 B
 C
 D
 E
 F
 G
 H
 I
 J
 K
DEF
 M
 N
 O
 P

CONTENTS

BASIC INSPECTION	3	Diagnosis Procedure	13
DIAGNOSIS AND REPAIR WORKFLOW	3	Component Inspection	15
Work Flow	3	DOOR MIRROR DEFOGGER	16
SYSTEM DESCRIPTION	4	Description	16
REAR WINDOW DEFOGGER SYSTEM	4	Component Function Check	16
System Diagram	4	Diagnosis Procedure	16
System Description	4	DRIVER SIDE DOOR MIRROR DEFOGGER ...	17
Component Parts Location	5	Description	17
Component Description	5	Component Function Check	17
DIAGNOSIS SYSTEM (BCM)	7	Diagnosis Procedure	17
COMMON ITEM	7	PASSENGER SIDE DOOR MIRROR DEFOGGER	19
COMMON ITEM : CONSULT-III Function (BCM -		Description	19
COMMON ITEM)	7	Component Function Check	19
REAR WINDOW DEFOGGER	8	Diagnosis Procedure	19
REAR WINDOW DEFOGGER : CONSULT-III		REAR WINDOW DEFOGGER SYSTEM	21
Function (BCM - REAR DEFOGGER)	8	Wiring Diagram - DEFOGGER SYSTEM -	21
DTC/CIRCUIT DIAGNOSIS	9	ECU DIAGNOSIS INFORMATION	28
POWER SUPPLY AND GROUND CIRCUIT	9	BCM (BODY CONTROL MODULE)	28
Diagnosis Procedure	9	Reference Value	28
REAR WINDOW DEFOGGER SWITCH	10	Wiring Diagram - BCM -	52
Description	10	Fail-safe	58
Component Function Check	10	DTC Inspection Priority Chart	60
Diagnosis Procedure	10	DTC Index	61
REAR WINDOW DEFOGGER RELAY	11	SYMPTOM DIAGNOSIS	64
Description	11	REAR WINDOW DEFOGGER DOES NOT	
Component Function Check	11	OPERATE	64
Diagnosis Procedure	11	Diagnosis Procedure	64
Component Inspection	12	REAR WINDOW DEFOGGER AND DOOR	
REAR WINDOW DEFOGGER	13	MIRROR DEFOGGER DO NOT OPERATE.	65
Description	13	Diagnosis Procedure	65
Component Function Check	13		

REAR WINDOW DEFOGGER DOES NOT OPERATE BUT BOTH DOOR MIRROR DEFOGGERS OPERATE.	66	Diagnosis Procedure	66	REAR WINDOW DEFOGGER INDICATOR DOES NOT ILLUMINATE	69
Diagnosis Procedure	66			Diagnosis Procedure	69
DOOR MIRROR DEFOGGER DOES NOT OPERATE	67	PRECAUTION	70	PRECAUTIONS	70
BOTH SIDES	67	Precaution for Supplemental Restraint System (SRS) "AIR BAG" and "SEAT BELT PRE-TENSIONER"	70	REMOVAL AND INSTALLATION	71
BOTH SIDES : Diagnosis Procedure	67			FILAMENT	71
DRIVER SIDE	67			Inspection and Repair	71
DRIVER SIDE : Diagnosis Procedure	67				
PASSENGER SIDE	67				
PASSENGER SIDE : Diagnosis Procedure	67				
ON IS NOT DISPLAYED WHEN PRESSING REAR WINDOW DEFOGGER SWITCH BUT IT IS OPERATED	68				

DIAGNOSIS AND REPAIR WORKFLOW

< BASIC INSPECTION >

BASIC INSPECTION

DIAGNOSIS AND REPAIR WORKFLOW

Work Flow

INFOID:000000005172669

DETAILED FLOW

1.OBTAIN INFORMATION ABOUT SYMPTOM

Interview the customer to obtain the malfunction information (conditions and environment when the malfunction occurred) as much as possible when the customer brings the vehicle in.

>> GO TO 2.

2.CHECK DTC

Perform self diagnosis with CONSULT-III

Is any DTC detected?

YES >> Refer to [BCS-79. "DTC Index"](#).

NO >> GO TO 3.

3.REPRODUCE THE MALFUNCTION INFORMATION

Check the malfunction on the vehicle that the customer describes.

Inspect the relation of the symptoms and the condition when the symptoms occur.

>> GO TO 4.

4.IDENTIFY THE MALFUNCTIONING SYSTEM WITH "SYMPTOM DIAGNOSIS"

Use "Symptom diagnosis" from the symptom inspection result in step 3. Then identify where to start performing the diagnosis based on possible causes and symptoms.

>> GO TO 5.

5.IDENTIFY MALFUNCTIONING PARTS WITH "COMPONENT DIAGNOSIS"

Perform the diagnosis with "Component diagnosis" of the applicable system.

>> GO TO 6.

6.REPAIR OR REPLACE THE MALFUNCTIONING PARTS

Repair or replace the specified malfunctioning parts.

>> GO TO 7.

7.FINAL CHECK

Check that malfunctions are not reproduced when obtaining the malfunction information from the customer, referring to the symptom inspection result in step 3.

Are all malfunctions corrected?

YES >> INSPECTION END

NO >> GO TO 4.

A
B
C
D
E
F
G
H
I
J
K
DEF
M
N
O
P

REAR WINDOW DEFOGGER SYSTEM

< SYSTEM DESCRIPTION >

SYSTEM DESCRIPTION

REAR WINDOW DEFOGGER SYSTEM

System Diagram

INFOID:000000005172670

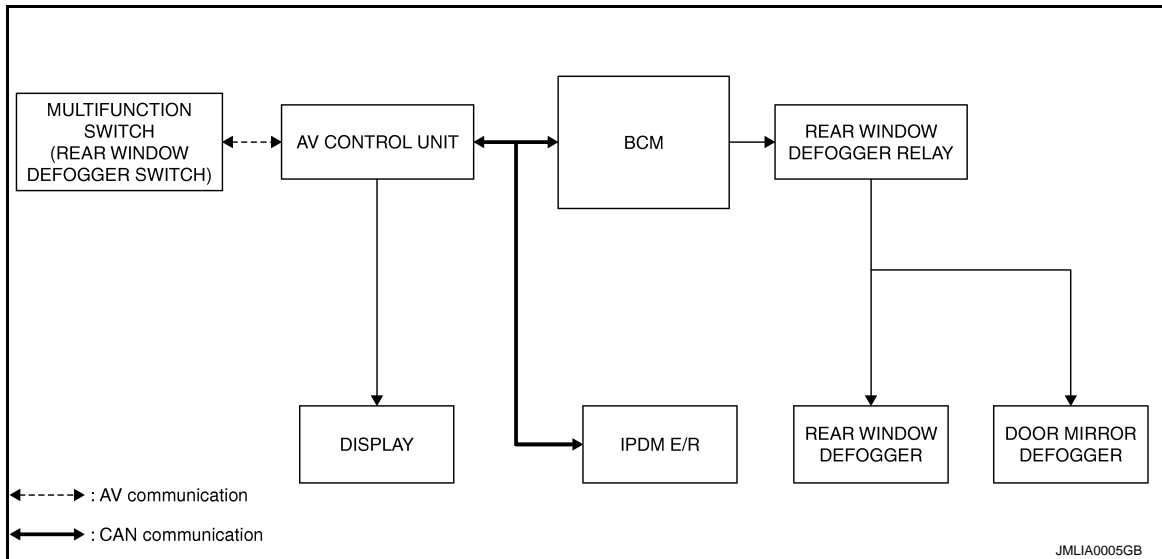

System Description

INFOID:000000005172671

Operation Description

- Turn rear window defogger switch ON when the ignition switch is turned ON. Then multifunction switch (rear window defogger switch) transmits rear window defogger switch signal to AV control unit via AV communication. AV control unit transmits rear window defogger switch signal to BCM via CAN communication.
- BCM turns rear window defogger relay ON and transmits rear window defogger control signal to IPDM E/R via CAN communication when rear window defogger switch signal is received.
- Rear window defogger and door mirror defogger (with mirror defogger) are supplied with power and operate when rear window defogger relay turns ON.
- IPDM E/R transmits rear window defogger control signal to AV control unit via CAN communication.
- AV control unit transmit rear defogger indicator signal to multifunction switch (rear window defogger switch) via AV communication then rear window defogger indicator is illuminated.

Timer function

- BCM turns rear window defogger relay ON for approximately 15 minutes when rear window defogger switch is turned ON. It makes rear window defogger and door mirror defogger (with mirror defogger) operate.
- Timer is canceled after pressing rear window defogger switch again during timer operation. Then BCM turns rear window defogger relay OFF. The same reaction also occurs during timer operation, if the ignition switch is turned OFF.

REAR WINDOW DEFOGGER SYSTEM

< SYSTEM DESCRIPTION >

Component Parts Location

INFOID:000000005172672

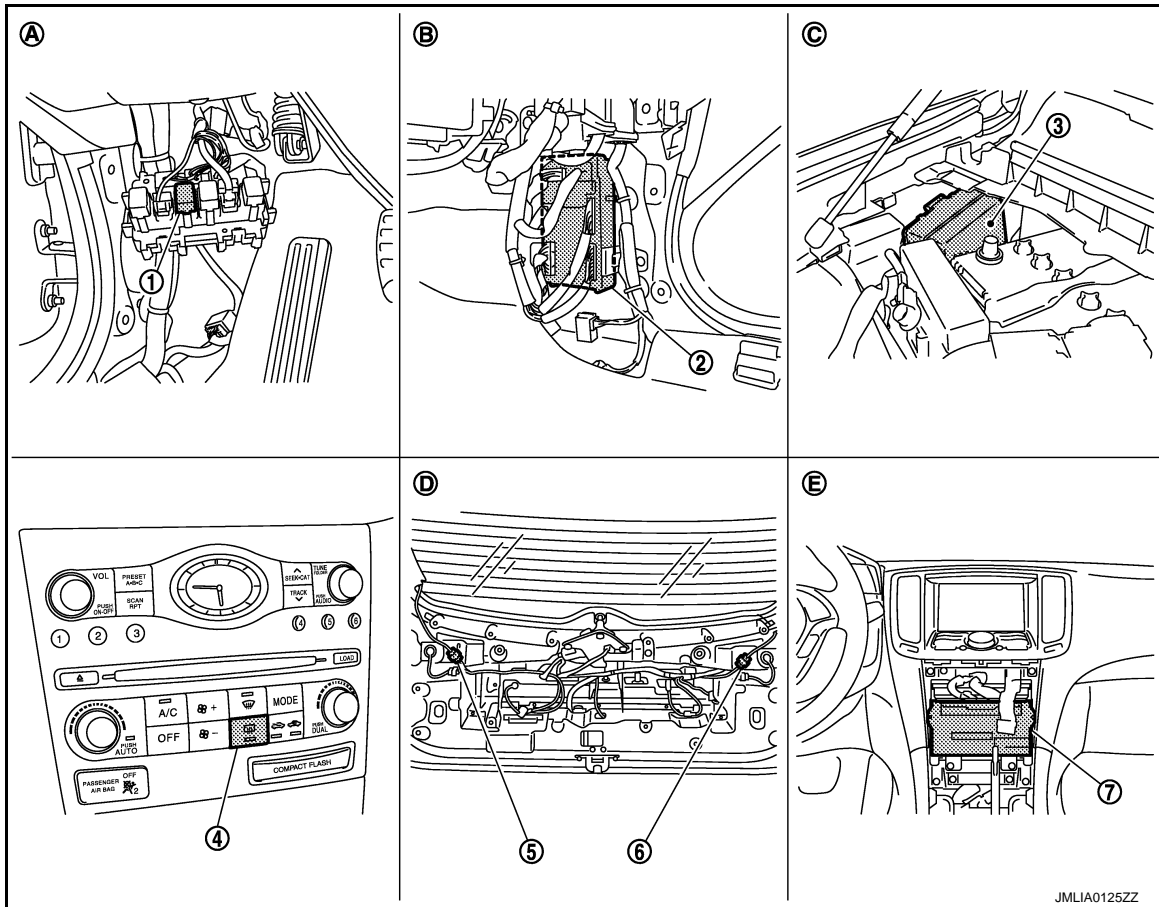

- | | | |
|---|--|--|
| 1. Rear window defogger relay (built-in relay box) | 2. BCM M118, M119, M122, M123 | 3. IPDM E/R E6 |
| 4. Rear window defogger switch (built-in multifunction switch M72) | 5. Rear window defogger connector D108 | 6. Rear window defogger connector D120 |
| 7. AV control unit
• With NAVI M87, M88
• Without NAVI M83, M85 | | |
| A. Dash side lower (driver side) | B. Dash side lower (passenger side) | C. Engine room dash panel (RH) |
| D. Behind back door finisher | E. Behind cluster lid C | |

Component Description

INFOID:000000005172673

Item	Function
BCM	<ul style="list-style-type: none"> Operates the rear window defogger with the operation of rear window defogger switch. Performs the timer control of rear window defogger.
Rear window defogger relay	<ul style="list-style-type: none"> Operates the rear window defogger and the door mirror defogger with the control signal from BCM.
IPDM E/R	<ul style="list-style-type: none"> Transmit rear window defogger control signal to AV control unit via CAN communication.
Multifunction switch (Rear window defogger switch)	<ul style="list-style-type: none"> The rear window defogger switch is installed. Turns the indicator lamp ON when detecting the operation of rear window defogger.
AV control unit	<ul style="list-style-type: none"> Displays the rear window defogger ON to the display when detecting the operation of rear window defogger.

REAR WINDOW DEFOGGER SYSTEM

< SYSTEM DESCRIPTION >

Rear window defogger	<ul style="list-style-type: none">• Heats the heating wire with the power supply from the rear window defogger relay to prevent the rear window from fogging up.
Door mirror defogger*	<ul style="list-style-type: none">• Heats the heating wire with the power supply from the rear window defogger relay to prevent the door mirror from fogging up.

*: With mirror defogger

DIAGNOSIS SYSTEM (BCM)

< SYSTEM DESCRIPTION >

DIAGNOSIS SYSTEM (BCM)

COMMON ITEM

COMMON ITEM : CONSULT-III Function (BCM - COMMON ITEM)

INFOID:000000005172674

APPLICATION ITEM

CONSULT-III performs the following functions via CAN communication with BCM.

Diagnosis mode	Function Description
Work Support	Changes the setting for each system function.
Self Diagnostic Result	Displays the diagnosis results judged by BCM.
CAN Diag Support Monitor	Monitors the reception status of CAN communication viewed from BCM. Refer to CONSULT-III operation manual.
Data Monitor	The BCM input/output signals are displayed.
Active Test	The signals used to activate each device are forcibly supplied from BCM.
Ecu Identification	The BCM part number is displayed.
Configuration	This function is not used even though it is displayed.

SYSTEM APPLICATION

BCM can perform the following functions for each system.

NOTE:

It can perform the diagnosis modes except the following for all sub system selection items.

×: Applicable item

System	Sub system selection item	Diagnosis mode		
		Work Support	Data Monitor	Active Test
Door lock	DOOR LOCK	×	×	×
Rear window defogger	REAR DEFOGGER		×	×
Warning chime	BUZZER		×	×
Interior room lamp timer	INT LAMP	×	×	×
Exterior lamp	HEAD LAMP	×	×	×
Wiper and washer	WIPER	×	×	×
Turn signal and hazard warning lamps	FLASHER	×	×	×
—	AIR CONDITIONER*		×	
Intelligent Key system	INTELLIGENT KEY	×	×	×
Combination switch	COMB SW		×	
Body control system	BCM	×		
IVIS - NATS	IMMU		×	×
Interior room lamp battery saver	BATTERY SAVER	×	×	×
Trunk open	TRUNK		×	
Vehicle security system	THEFT ALM	×	×	×
RAP system	RETAINED PWR		×	
Signal buffer system	SIGNAL BUFFER		×	×
TPMS	TPMS (AIR PRESSURE MONITOR)	×	×	×

*: This item is displayed, but is not used.

FREEZE FRAME DATA (FFD) AND IGN COUNTER

Freeze Frame Data

The BCM records the following condition at the moment a particular DTC is detected.

- Vehicle Speed
- Odo/Trip Meter

DIAGNOSIS SYSTEM (BCM)

< SYSTEM DESCRIPTION >

- Vehicle Condition (BCM detected condition)

CONSULT screen terms	Description
SLEEP>LOCK	While turning BCM status from low power consumption mode to normal mode (Power supply position is "LOCK")
SLEEP>OFF	While turning BCM status from low power consumption mode to normal mode (Power supply position is "OFF".)
LOCK>ACC	While turning power supply position from "LOCK" to "ACC"
ACC>ON	While turning power supply position from "ACC" to "IGN"
RUN>ACC	While turning power supply position from "RUN" to "ACC" (Vehicle is stopping and selector lever is except P position.)
CRANK>RUN	While turning power supply position from "CRANKING" to "RUN" (From cranking up the engine to run it)
RUN>URGENT	While turning power supply position from "RUN" to "ACC" (Emergency stop operation)
ACC>OFF	While turning power supply position from "ACC" to "OFF"
OFF>LOCK	While turning power supply position from "OFF" to "LOCK"
OFF>ACC	While turning power supply position from "OFF" to "ACC"
ON>CRANK	While turning power supply position from "IGN" to "CRANKING"
OFF>SLEEP	While turning BCM status from normal mode (Power supply position is "OFF".) to low power consumption mode
LOCK>SLEEP	While turning BCM status from normal mode (Power supply position is "LOCK".) to low power consumption mode
LOCK	Power supply position is "LOCK" (Ignition switch OFF with steering is locked.)
OFF	Power supply position is "OFF" (Ignition switch OFF with steering is unlocked.)
ACC	Power supply position is "ACC" (Ignition switch ACC)
ON	Power supply position is "IGN" (Ignition switch ON with engine stopped)
ENGINE RUN	Power supply position is "RUN" (Ignition switch ON with engine running)
CRANKING	Power supply position is "CRANKING" (At engine cranking)

IGN Counter

IGN counter indicates the number of times that ignition switch is turned ON after DTC is detected.

- The number is 0 when a malfunction is detected now.
- The number increases like 1 → 2 → 3...38 → 39 after returning to the normal condition whenever ignition switch OFF → ON.
- The number is fixed to 39 until the self-diagnosis results are erased if it is over 39.

REAR WINDOW DEFOGGER

REAR WINDOW DEFOGGER : CONSULT-III Function (BCM - REAR DEFOGGER)

INFOID:000000005172675

Data monitor

Monitor Item	Description
REAR DEF SW	This is displayed even when it is not equipped.
PUSH SW	Indicates [ON/OFF] condition of push switch.

ACTIVE TEST

Test Item	Description
REAR DEFOGGER	This test is able to check rear window defogger operation. Rear window defogger operates when "ON" on CONSULT-III screen is touched.

POWER SUPPLY AND GROUND CIRCUIT

< DTC/CIRCUIT DIAGNOSIS >

DTC/CIRCUIT DIAGNOSIS

POWER SUPPLY AND GROUND CIRCUIT

Diagnosis Procedure

INFOID:000000005172676

1. CHECK FUSE AND FUSIBLE LINK

Check that the following fuse and fusible link are not blown.

Terminal No.	Signal name	Fuse and fusible link No.
1	Battery power supply	K
11		10

Is the fuse blown?

YES >> Replace the blown fuse or fusible link after repairing the affected circuit if a fuse or fusible link is blown.

NO >> GO TO 2.

2. CHECK POWER SUPPLY CIRCUIT

1. Turn ignition switch OFF.
2. Disconnect BCM connectors.
3. Check voltage between BCM harness connector and ground.

(+)		(-)	Voltage (V) (Approx.)
BCM			
Connector	Terminal	Ground	Battery voltage
M118	1		
M119	11		

Is the inspection result normal?

YES >> GO TO 3.

NO >> Repair harness or connector.

3. CHECK GROUND CIRCUIT

Check continuity between BCM harness connector and ground.

BCM		Ground	Continuity
Connector	Terminal		
M119	13		Existed

Is the inspection result normal?

YES >> INSPECTION END

NO >> Repair harness or connector.

REAR WINDOW DEFOGGER SWITCH

< DTC/CIRCUIT DIAGNOSIS >

REAR WINDOW DEFOGGER SWITCH

Description

INFOID:000000005172677

- The rear window defogger is operated by turning the rear window defogger switch ON.
- The indicator lamp in the rear window defogger illuminates when the rear window defogger is operating.

Component Function Check

INFOID:000000005172678

1. CHECK REAR WINDOW DEFOGGER SWITCH FUNCTION

Check that the indicator lamp of rear window defogger illuminates when rear window defogger switch ON.

Is the inspection result normal?

- YES >> Rear window defogger switch function is OK.
NO >> Refer to [DEF-10, "Diagnosis Procedure"](#)

Diagnosis Procedure

INFOID:000000005172679

1. CHECK MULTIFUNCTION SWITCH (REAR WINDOW DEFOGGER SWITCH)

Does multifunction switch operate normally?

- Base audio without navigation system. Refer to [AV-22, "On Board Diagnosis Function"](#).
- Bose audio without navigation system. Refer to [AV-165, "On Board Diagnosis Function"](#).
- Bose audio with navigation system. Refer to [AV-367, "On Board Diagnosis Function"](#).

Is the inspection result normal?

- YES >> INSPECTION END
NO >> Replace multifunction switch (rear window defogger switch). Refer to [AV-138, "Removal and Installation"](#) (Base audio without navigation system), [AV-333, "Removal and Installation"](#) (Bose audio without navigation system) or [AV-536, "Removal and Installation"](#) (Bose audio with navigation system).

REAR WINDOW DEFOGGER RELAY

< DTC/CIRCUIT DIAGNOSIS >

REAR WINDOW DEFOGGER RELAY

Description

INFOID:000000005172680

Power is supplied to the rear window defogger with BCM control.

Component Function Check

INFOID:000000005172681

1.CHECK REAR WINDOW DEFOGGER RELAY POWER SUPPLY CIRCUIT

1. Perform Active Test ("REAR DEFOGGER") with CONSULT-III.
2. Touch "ON".
3. Check that the rear window heating wire is getting warmer.

Is the inspection result normal?

- YES >> Rear window defogger relay power supply circuit is OK.
NO >> Refer to [DEF-11. "Diagnosis Procedure"](#)

Diagnosis Procedure

INFOID:000000005172682

1.CHECK FUSE

1. Turn ignition switch OFF.
2. Check 10A fuse [No.3, located in fuse block (J/B)].

Is the inspection result normal?

- YES >> GO TO 2.
NO >> Replace the blown fuse after repairing the affected circuit if a fuse is blown.

2.CHECK REAR WINDOW DEFOGGER CIRCUIT 1

1. Turn ignition switch ON.
2. Check voltage between BCM harness connector and ground.

(+)		(-)	Condition	Voltage (V) (Approx.)
BCM				
Connector	Terminal			
M123	151	Ground	Rear window defogger switch: ON	0
			Rear window defogger switch: OFF	Battery voltage

Is the inspection result normal?

- YES >> Rear window defogger power supply circuit is OK.
NO >> GO TO 3.

3.CHECK REAR WINDOW DEFOGGER CIRCUIT 2

1. Turn ignition switch OFF.
2. Disconnect BCM connector and fuse block (J/B).
3. Check continuity between BCM harness connector and fuse block (J/B) harness connector.

BCM		Fuse block (J/B)		Continuity
Connector	Terminal	Connector	Terminal	
M123	151	M2	4B	Existed

Is the inspection result normal?

- YES >> GO TO 4.
NO >> Repair or replace harness.

4.CHECK REAR WINDOW DEFOGGER RELAY

1. Disconnect rear window defogger relay,
2. Check rear window defogger relay.
Refer to [DEF-12. "Component Inspection"](#)

Is the inspection result normal?

A
B
C
D
E
F
G
H
I
J
K
DEF
M
N
O
P

REAR WINDOW DEFOGGER RELAY

< DTC/CIRCUIT DIAGNOSIS >

- YES >> GO TO 5.
 NO >> Replace rear window defogger relay.

5. CHECK FUSE BLOCK (J/B)

1. Install the rear window defogger relay.
2. Turn ignition switch ON.
3. Check voltage between fuse block (J/B) connector (fuse block side) and ground.

(+)		(-)	Voltage (V) (Approx.)
Fuse block (J/B)			
Connector	Terminal		
M2	4B	Ground	Battery voltage

Is the inspection result normal?

- YES >> GO TO 6.
 NO >> Replace fuse block (J/B).

6. CHECK INTERMITTENT INCIDENT

Check intermittent incident.
 Refer to [GI-37, "Intermittent Incident"](#)

>> INSPECTION END.

Component Inspection

INFOID:000000005172683

1. CHECK REAR WINDOW DEFOGGER RELAY

1. Turn ignition switch OFF.
2. Disconnect rear window defogger relay.
3. Check rear window defogger relay.

Rear window defogger relay		Condition	Continuity
Terminal			
3	5	12 V direct current supply between terminals 1 and 2.	Existed
		No current supply	Not existed

Is the inspection result normal?

- YES >> INSPECTION END.
 NO >> Replace rear window defogger relay.

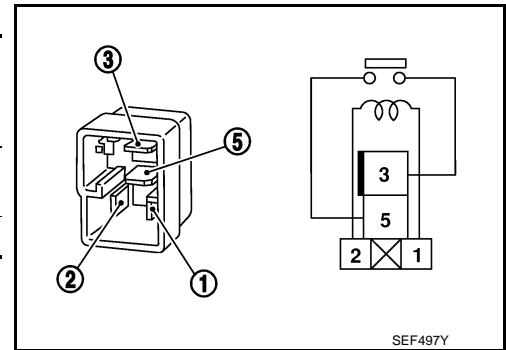

REAR WINDOW DEFOGGER

< DTC/CIRCUIT DIAGNOSIS >

REAR WINDOW DEFOGGER

Description

INFOID:000000005172684

Heats the heating wire with the power supply from the rear window defogger relay to prevent the rear window from fogging up.

Component Function Check

INFOID:000000005172685

1.CHECK REAR WINDOW DEFOGGER

1. Perform Active Test ("REAR DEFOGGER") with CONSULT-III.
2. Touch "ON".
3. Check that the rear window heating wire is getting warmer.

Is the inspection result normal?

- YES >> Rear window defogger is OK.
NO >> Refer to [DEF-13. "Diagnosis Procedure"](#)

Diagnosis Procedure

INFOID:000000005172686

1.CHECK FUSE

1. Turn ignition switch OFF.
2. Check the following.
 - 20A fuse [No.14, located in fuse block (J/B)]
 - 20A fuse [No.15, located in fuse block (J/B)]

Is the inspection result normal?

- YES >> GO TO 2.
NO >> Replace the blown fuse after repairing the affected circuit if a fuse is blown.

2.CHECK POWER SUPPLY CIRCUIT

1. Turn ignition switch ON.
2. Check voltage between rear window defogger harness connector and ground.

(+)		(-)	Condition	Voltage (V) (Approx.)
Connector	Terminal			
D108	1	Ground	Rear window defogger switch: ON	Battery voltage
			Rear window defogger switch: OFF	0

Is the inspection result normal?

- YES >> GO TO 3.
NO >> GO TO 4.

3.CHECK GROUND CIRCUIT

1. Turn ignition switch OFF.
2. Disconnect rear window defogger connector.
3. Check continuity between rear window defogger harness connector and ground.

Rear window defogger		Ground	Continuity
Connector	Terminal		
D120	2		Existed

Is the inspection result normal?

- YES >> GO TO 9.
NO >> Repair or replace harness between rear window defogger and ground.

4.CHECK REAR WINDOW DEFOGGER CIRCUIT 1

REAR WINDOW DEFOGGER

< DTC/CIRCUIT DIAGNOSIS >

1. Turn ignition switch OFF.
2. Disconnect condenser connector.
3. Check continuity between condenser harness connector and rear window defogger harness connector.

Condenser		Rear window defogger		Continuity
Connector	Terminal	Connector	Terminal	
D104	2	D108	1	Existed

Is the inspection result normal?

YES >> GO TO 5.

NO >> Repair or replace harness between condenser and rear window defogger.

5.CHECK REAR WINDOW DEFOGGER CIRCUIT 2

1. Disconnect fuse block (J/B) connector.
2. Check continuity between fuse block (J/B) harness connector and condenser harness connector.

Fuse block (J/B)		Condenser		Continuity
Connector	Terminal	Connector	Terminal	
B6	10G	D105	1	Existed
	11G			

Is the inspection result normal?

YES >> GO TO 6.

NO >> Repair or replace harness between fuse block (J/B) and condenser.

6.CHECK FUSE BLOCK (J/B)

1. Turn ignition switch ON.
2. Check voltage between fuse block (J/B) (fuse block side) and ground.

(+)		(-)	Condition	Voltage (V) (Approx.)
Fuse block (J/B)				
Connector	Terminal			
B6	10G	Ground	Rear window defogger switch: ON	Battery voltage
			Rear window defogger switch: OFF	0
	11G		Rear window defogger switch: ON	Battery voltage
			Rear window defogger switch: OFF	0

Is the inspection result normal?

YES >> GO TO 7.

NO >> GO TO 8.

7.CHECK CONDENSER

Check condenser. Refer to [DEF-15, "Component Inspection"](#)

Is the inspection result normal?

YES >> GO TO 10.

NO >> Replace condenser.

8.CHECK REAR WINDOW DEFOGGER RELAY

Check rear window defogger relay. Refer to [DEF-12, "Component Inspection"](#)

Is the inspection result normal?

YES >> Replace fuse block (J/B)

NO >> Replace rear window defogger relay.

9.CHECK FILAMENT

Check the filament for damage or blown.

Refer to [DEF-71, "Inspection and Repair"](#)

Is the inspection result normal?

REAR WINDOW DEFOGGER

< DTC/CIRCUIT DIAGNOSIS >

YES >> GO TO 10.
NO >> Repair filament.

10.CHECK INTERMITTENT INCIDENT

Check intermittent incident.
Refer to [GI-37. "Intermittent Incident"](#)

>> INSPECTION END

Component Inspection

INFOID:000000005172687

1.CHECK CONDENSER

1. Check continuity between condenser connector and ground part of condenser.

Condenser		Ground part of condenser	Continuity
Connector	Terminal		
D105	1		Not existed
D104	2		

2. Check condenser terminals.

Condenser				Continuity
Connector	Terminal	Connector	Terminal	
D105	1	D104	2	Existed

Is the inspection result normal?

YES >> INSPECTION END
NO >> Repair condenser.

A
B
C
D
E
F
G
H
I
J
K
M
N
O
P

DEF

DOOR MIRROR DEFOGGER

< DTC/CIRCUIT DIAGNOSIS >

DOOR MIRROR DEFOGGER

Description

INFOID:000000005172688

Power is supplied to the door mirror defogger with BCM control.

Component Function Check

INFOID:000000005172689

1.CHECK DOOR MIRROR DEFOGGER

1. Perform Active Test ("REAR DEFOGGER") with CONSULT-III.
2. Touch "ON".
3. Check that both side door mirror glass is getting warmer.

Is the inspection result normal?

- YES >> Door mirror defogger is OK.
NO >> Refer to [DEF-16. "Diagnosis Procedure"](#)

Diagnosis Procedure

INFOID:000000005172690

1.CHECK FUSE

1. Turn ignition switch OFF.
2. Check 10A fuse [No.13, located in fuse block (J/B)].

Is the inspection result normal?

- YES >> GO TO 2.
NO >> Replace the blown fuse after repairing the affected circuit if a fuse is blown.

2.CHECK FUSE BLOCK (J/B)

1. Disconnect fuse block (J/B) connector.
2. Turn ignition switch ON.
3. Check voltage between fuse block (J/B) connector (fuse block side) and ground.

(+)		(-)	Condition	Voltage (V) (Approx.)
Fuse block (J/B)				
Connector	Terminal			
M3	9C	Ground	Rear window defogger switch: ON	Battery voltage
			Rear window defogger switch: OFF	0
	10C		Rear window defogger switch: ON	Battery voltage
			Rear window defogger switch: OFF	0

Is the inspection result normal?

- YES >> GO TO 3.
NO >> Replace fuse block (J/B).

3.CHECK INTERMITTENT INCIDENT

Check intermittent incident.

Refer to [GI-37. "Intermittent Incident"](#).

>> INSPECTION END

DRIVER SIDE DOOR MIRROR DEFOGGER

< DTC/CIRCUIT DIAGNOSIS >

DRIVER SIDE DOOR MIRROR DEFOGGER

Description

INFOID:000000005172691

Heats the heating wire with the power supply from the rear window defogger relay to prevent the door mirror from fogging up.

Component Function Check

INFOID:000000005172692

1.CHECK DRIVER SIDE DOOR MIRROR DEFOGGER

1. Perform Active Test ("REAR DEFOGGER") with CONSULT-III.
2. Touch "ON".
3. Check that the driver side door mirror glass is getting warmer.

Is the inspection result normal?

- YES >> Driver side door mirror defogger is OK.
NO >> Refer to [DEF-17, "Diagnosis Procedure"](#)

Diagnosis Procedure

INFOID:000000005172693

1.CHECK POWER SUPPLY CIRCUIT

1. Turn ignition switch OFF.
2. Disconnect door mirror (driver side) connector.
3. Turn ignition switch ON.
4. Check voltage between door mirror (driver side) harness connector and ground.

(+)		(-)	Condition	Voltage (V) (Approx.)
Connector	Terminal			
D3	7	Ground	Rear window defogger switch: ON	Battery voltage
			Rear window defogger switch: OFF	0

Is the inspection result normal?

- YES >> GO TO 4.
NO >> GO TO 2.

2.CHECK DRIVER SIDE DOOR MIRROR DEFOGGER CIRCUIT

1. Turn ignition switch OFF.
2. Disconnect fuse block (J/B) connector.
3. Check continuity between fuse block (J/B) harness connector and door mirror (driver side) harness connector.

Fuse block (J/B)		Door mirror (driver side)		Continuity
Connector	Terminal	Connector	Terminal	
M3	10C	D3	7	Existed

Is the inspection result normal?

- YES >> GO TO 3.
NO >> Repair or replace harness between fuse block (J/B) and door mirror (driver side).

3.CHECK FUSE BLOCK (J/B) OUTPUT SIGNAL

1. Turn ignition switch ON.
2. Check voltage between fuse block (J/B) harness connector and ground.

DRIVER SIDE DOOR MIRROR DEFOGGER

< DTC/CIRCUIT DIAGNOSIS >

(+)		(-)	Condition	Voltage (V) (Approx.)
Fuse block (J/B)				
Connector	Terminal			
M3	10C	Ground	Rear window defogger switch: ON	Battery voltage
			Rear window defogger switch: OFF	0

Is the inspection result normal?

YES >> GO TO 5.

NO >> Replace fuse block (J/B).

4. CHECK GROUND CIRCUIT

1. Turn ignition switch OFF.
2. Check continuity between door mirror (driver side) harness connector and ground.

Door mirror (driver side)		Ground	Continuity
Connector	Terminal		
D3	19		

Is the inspection result normal?

YES >> Replace door mirror glass (driver side). Refer to [MIR-116, "GLASS MIRROR : Disassembly and Assembly"](#).

NO >> Repair or replace harness between door mirror (driver side) and ground.

5. CHECK INTERMITTENT INCIDENT

Check intermittent incident.

Refer to [GI-37, "Intermittent Incident"](#)

>> INSPECTION END

PASSENGER SIDE DOOR MIRROR DEFOGGER

< DTC/CIRCUIT DIAGNOSIS >

PASSENGER SIDE DOOR MIRROR DEFOGGER

Description

INFOID:000000005172694

Heats the heating wire with the power supply from the rear window defogger relay to prevent the door mirror from fogging up.

Component Function Check

INFOID:000000005172695

1.CHECK PASSENGER SIDE DOOR MIRROR DEFOGGER

1. Perform Active Test ("REAR DEFOGGER") with CONSULT-III.
2. Touch "ON".
3. Check that the passenger side door mirror glass is getting warmer.

Is the inspection result normal?

- YES >> Passenger side door mirror defogger is OK.
NO >> Refer to [DEF-19, "Diagnosis Procedure"](#)

Diagnosis Procedure

INFOID:000000005172696

1.CHECK POWER SUPPLY CIRCUIT

1. Turn ignition switch OFF.
2. Disconnect door mirror (passenger side) connector.
3. Turn ignition switch ON.
4. Check voltage between door mirror (passenger side) harness connector and ground.

(+)		(-)	Condition	Voltage (V) (Approx.)
Connector	Terminal			
D33	7	Ground	Rear window defogger switch: ON	Battery voltage
			Rear window defogger switch: OFF	0

Is the inspection result normal?

- YES >> GO TO 4.
NO >> GO TO 2.

2.CHECK PASSENGER SIDE DOOR MIRROR DEFOGGER CIRCUIT

1. Turn ignition switch OFF.
2. Disconnect fuse block (J/B) connector.
3. Check continuity between fuse block (J/B) harness connector and door mirror (passenger side) harness connector.

Fuse block (J/B)		Door mirror (passenger side)		Continuity
Connector	Terminal	Connector	Terminal	
M3	9C	D33	7	Existed

Is the inspection result normal?

- YES >> GO TO 3.
NO >> Repair or replace harness between fuse block (J/B) and door mirror (passenger side).

3.CHECK FUSE BLOCK (J/B) OUTPUT SIGNAL

1. Turn ignition switch ON.
2. Check voltage between fuse block (J/B) harness connector and ground.

PASSENGER SIDE DOOR MIRROR DEFOGGER

< DTC/CIRCUIT DIAGNOSIS >

(+)		(-)	Condition	Voltage (V) (Approx.)
Fuse block (J/B)				
Connector	Terminal			
M3	9C	Ground	Rear window defogger switch: ON	Battery voltage
			Rear window defogger switch: OFF	0

Is the inspection result normal?

YES >> GO TO 5.

NO >> Replace fuse block (J/B).

4. CHECK GROUND CIRCUIT

1. Turn ignition switch OFF.
2. Check continuity between door mirror (passenger side) harness connector and ground.

Door mirror (passenger side)		Ground	Continuity
Connector	Terminal		
D33	19		Existed

Is the inspection result normal?

YES >> Replace door mirror glass (passenger side). Refer to [MIR-116. "GLASS MIRROR : Disassembly and Assembly"](#).

NO >> Repair or replace harness between door mirror (passenger side) and ground.

5. CHECK INTERMITTENT INCIDENT

Check intermittent incident.

Refer to [GI-37. "Intermittent Incident"](#)

>> INSPECTION END

REAR WINDOW DEFOGGER SYSTEM

< DTC/CIRCUIT DIAGNOSIS >

REAR WINDOW DEFOGGER SYSTEM

Wiring Diagram - DEFOGGER SYSTEM -

INFOID:000000005172697

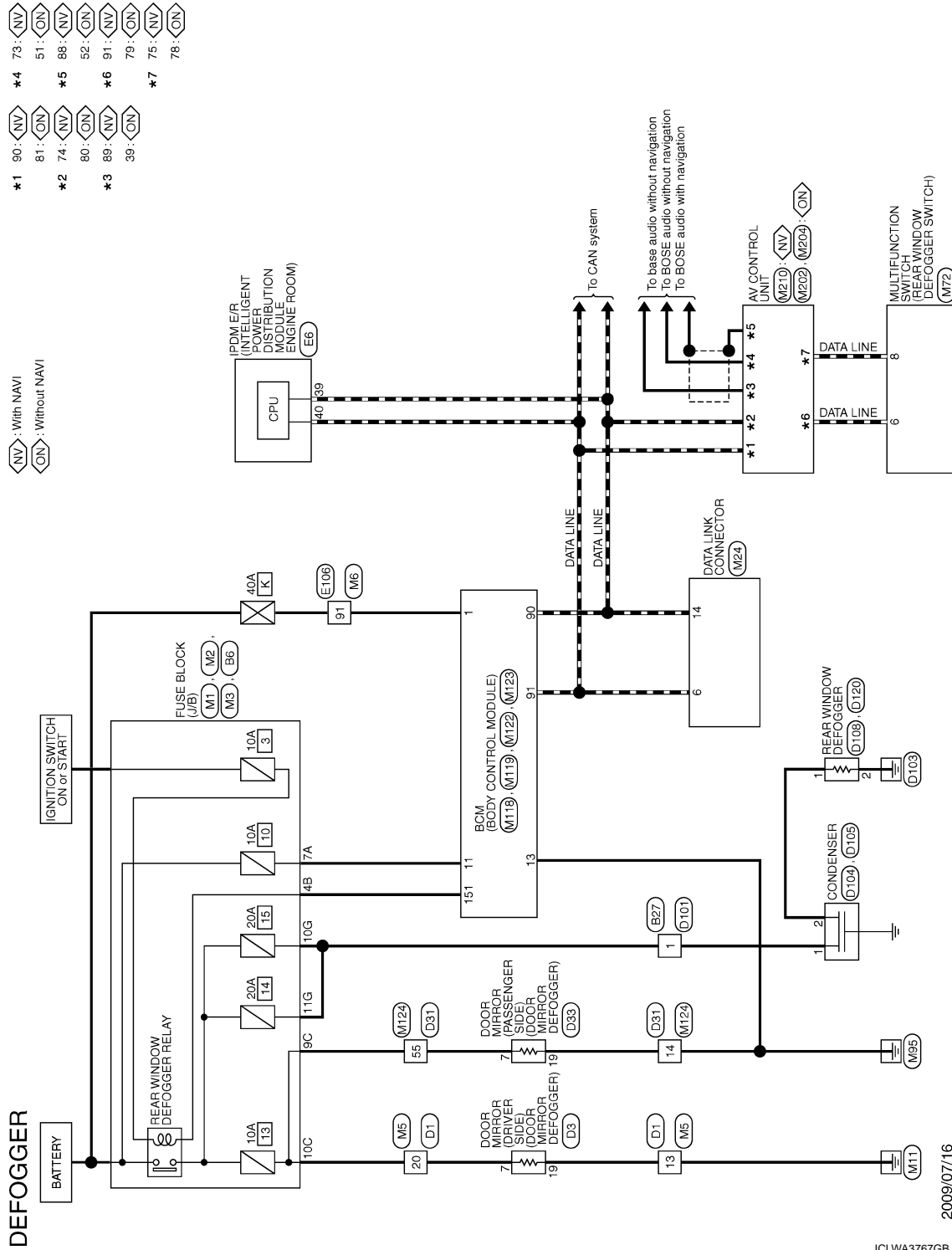

- *1 90: <NV> 73: <NV>
- *2 81: <ON> 51: <ON>
- *3 80: <ON> 88: <NV>
- *4 89: <NV> 52: <ON>
- *5 39: <ON> 91: <NV>
- *6 75: <NV> 79: <ON>
- *7 78: <ON>

<NV>: With NAVI
<ON>: Without NAVI

A
B
C
D
E
F
G
H
I
J
K
M
N
O
P

REAR WINDOW DEFOGGER SYSTEM

< DTC/CIRCUIT DIAGNOSIS >

DEFOGGER

Connector No.	B16
Connector Name	FUSE BLOCK (J/B)
Connector Type	HS12FBR-CS



1	2	3	4	5	6	7	8	9	10	11	12	13	14	15	16	17	18	19	20	21	22	23	24	25	26	27	28	29	30	31	32	33	34	35	36	37	38	39	40
5G	4G	3G	2G	1G	6G	7G	8G	9G	10G	11G	12G	13G	14G	15G	16G	17G	18G	19G	20G	21G	22G	23G	24G	25G	26G	27G	28G	29G	30G	31G	32G	33G	34G	35G	36G	37G	38G	39G	40G

Terminal No.	Color of Wire	Signal Name [Specification]
4G	R	-
5G	LG	-
10G	W	-
11G	W	-
12G	GR	-

Connector No. B27

Connector Name WIRE TO WIRE

Connector Type M00BMW-LC



1	2	3
4	5	6

Terminal No.	Color of Wire	Signal Name [Specification]
1	R	-
2	G	-
3	B	-
4	SB	-
5	L	-
6	B	-

Connector No.	D1
Connector Name	WIRE TO WIRE
Connector Type	TH40PW-CS15



1	2	3	4	5	6	7	8	9	10	11	12	13	14	15	16	17	18	19	20	21	22	23	24	25	26	27	28	29	30	31	32	33	34	35	36	37	38	39	40					
16	14	13	12	11	10	9	8	7	6	5	4	3	2	1	15	14	13	12	11	10	9	8	7	6	5	4	3	2	1	15	14	13	12	11	10	9	8	7	6	5	4	3	2	1

Terminal No.	Color of Wire	Signal Name [Specification]
3	V	-
4	W	-
5	L	-
6	O	-
7	GR	-
8	W	-
9	O	-
10	BR	-
11	P	-
12	LG	-
13	B	-
14	Y	-
15	W	-
16	R	-
17	W	-
18	G	-
19	Y	-
20	W	-
21	O	-
22	P	-
23	BR	-
24	V	-
25	GR	-
26	Y	-
27	B	-
28	SHIELD	-
29	LG	-
30	G	-
31	W	-
32	G	-
33	L	-
34	SB	-
35	R	-
36	LG	-
37	R	-
38	P	-
39	O	-
40	BR	-

41	L	-
42	GR	- [With automatic drive positioner]
43	BR	- [Without automatic drive positioner]
43	O	- [With automatic drive positioner]
44	W	- [Without automatic drive positioner]
44	GR	- [With automatic drive positioner]
45	Y	- [Without automatic drive positioner]
45	G	- [With automatic drive positioner]
46	G	- [Without automatic drive positioner]
46	V	- [With automatic drive positioner]
49	GR	- [Without automatic drive positioner]
50	B	-
52	R	-
53	SB	-
54	O	-
55	Y	-

Connector No. D3

Connector Name DOOR MIRROR (DRIVER SIDE)

Connector Type TH24MW-NH



1	2	3	4	5	6	7	8	9	10	11	12	13	14	15	16	17	18	19	20	21	22	23	24	
12	11	10	9	8	7	6	5	4	3	2	1	11	10	9	8	7	6	5	4	3	2	1	11	10

Terminal No.	Color of Wire	Signal Name [Specification]
2	O	-
3	B	SIDE CAMERA LH COMM
5	Y	SIDE CAMERA LH IMAGE SIGNAL
6	R	SIDE CAMERA LH POWER SUPPLY
7	W	-
10	G	-
11	P	-
12	O	-
14	LG	-
17	G	SIDE CAMERA LH IMAGE GND
18	W	SIDE CAMERA LH GND
19	B	-
21	GR	-
22	BR	-
23	Y	-
24	V	-

Connector No.	D31
Connector Name	WIRE TO WIRE
Connector Type	TH40PW-CS15



1	2	3	4	5	6	7	8	9	10	11	12	13	14	15	16	17	18	19	20	21	22	23	24	25	26	27	28	29	30	31	32	33	34	35	36	37	38	39	40					
18	14	13	12	11	10	9	8	7	6	5	4	3	2	1	18	14	13	12	11	10	9	8	7	6	5	4	3	2	1	18	14	13	12	11	10	9	8	7	6	5	4	3	2	1

Terminal No.	Color of Wire	Signal Name [Specification]
7	R	-
8	BR	-
9	V	-
12	P	-
13	LG	-
14	B	-
15	W	-
18	R	-
19	Y	-
20	B	- [With BOSE audio]
20	R	- [Without BOSE audio]
21	G	- [With BOSE audio]
21	BR	- [Without BOSE audio]
22	V	-
23	P	-
24	W	-
23	SB	-
26	R	-
29	SHIELD	-
30	W	-
31	LG	-
32	BR	-
33	O	-
34	GR	-
35	G	-
43	Y	-
44	V	-
45	P	-
46	W	-
52	G	-
53	GR	-
54	O	-
55	L	-

REAR WINDOW DEFOGGER SYSTEM

< DTC/CIRCUIT DIAGNOSIS >

DEFOGGER

Connector No.	D33
Connector Name	DOOR MIRROR (PASSENGER SIDE)
Connector Type	TH34MW-NH

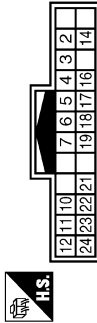

Connector No.	D104
Connector Name	CONDENSER
Connector Type	PD1FB-A



Connector No.	D120
Connector Name	REAR WINDOW DEFOGGER
Connector Type	IM02MB-P-LC



Terminal No.	Color of Wire	Signal Name [Specification]
3	W	SIDE CAMERA RH COMM
4	LG	SIDE CAMERA RH IMAGE SIGNAL
5	B	SIDE CAMERA RH POWER SUPPLY
6	R	-
7	L	-
10	G	-
11	GR	-
12	O	-
16	BR	-
17	G	SIDE CAMERA RH IMAGE GND
18	Y	SIDE CAMERA RH GND
19	B	-
21	P	-
22	Y	-
23	W	-
24	V	-

Connector No.	D101
Connector Name	WIRE TO WIRE
Connector Type	IM06FW-LC

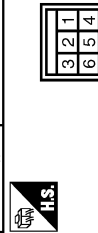

Terminal No.	2	Color of Wire	Y	Signal Name [Specification]	-
--------------	---	---------------	---	-----------------------------	---

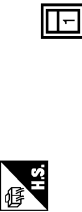

Terminal No.	2	Color of Wire	B	Signal Name [Specification]	-
--------------	---	---------------	---	-----------------------------	---

Connector No.	E6
Connector Name	POWER INTELLIGENT POWER DISTRIBUTION MODULE (ENGINE ROOM)
Connector Type	TH08FW-NH

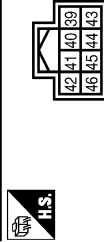

Terminal No.	1	Color of Wire	R	Signal Name [Specification]	-
--------------	---	---------------	---	-----------------------------	---

Connector No.	D108
Connector Name	REAR WINDOW DEFOGGER
Connector Type	IM02MB-P-LC

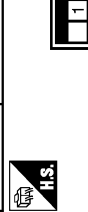

Terminal No.	Color of Wire	Signal Name [Specification]
39	P	-
40	L	-
41	B/W	-
42	Y	-
43	SB	-
44	BR	-
45	G	-
46	R	-

Terminal No.	Color of Wire	Signal Name [Specification]
1	R	-
2	G	-
3	B	-
4	Y	-
5	V	-
6	B	-

JCLWA3769GB

A
B
C
D
E
F
G
H
I
J
K
DEF
M
N
O
P

REAR WINDOW DEFOGGER SYSTEM

< DTC/CIRCUIT DIAGNOSIS >

DEFOGGER

Connector No.	E106
Connector Name	WIRE TO WIRE
Connector Type	TH00PW-CS16-1M4

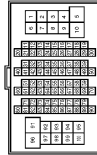

Terminal No.	Color of Wire	Signal Name [Specification]
1	R	
2	W	
3	B	
4	GR	
5	GR	
8	Y	
9	BR	
10	O	
11	SB	
12	O	
13	L	
14	R	
15	P	
16	V	
17	SB	
18	V	
20	O	
21	L	
22	V	
23	G	
24	P	
25	Y	
26	V	
27	W	
28	G	
31	O	
32	W	
33	B	
34	R	
35	G	
36	SHIELD	
37	V	
38	BR	
39	O	
41	W	
42	G	
43	BR	
45	W	

49	L	
50	P	
51	L	
52	L	
53	O	
54	P	
56	BR	
57	BR	
59	W	
60	LG	
61	G	
62	SB	
63	W	
64	B	
65	G	
66	R	
67	SHIELD	
68	Y	
69	LG	
70	W	
71	R	
72	Y	
73	B	
74	BR	
74	L	
75	G	
75	W	
76	W	
76	Y	
77	R	
77	P	
78	L	
78	BR	
79	Y	
79	L	
80	SB	
81	R	
82	SB	
83	O	
84	G	
85	L	
86	P	
87	V	
89	GR	
90	SHIELD	
91	W	
93	Y	
93	V	
94	LG	
95	O	
95	G	
96	P	
97	R	

98	SHIELD
99	L
100	P



Connector No.	M1
Connector Name	FUSE BLOCK (J/B)
Connector Type	NS06PW-M2



Terminal No.	Color of Wire	Signal Name [Specification]
1A	GR	
2A	G	
3A	L	
4A	P	
5A	V	
6A	Y	
7A	R	
8A	L	

Connector No.	M3
Connector Name	FUSE BLOCK (J/B)
Connector Type	NS12PW-CS

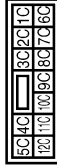

Terminal No.	Color of Wire	Signal Name [Specification]
6C	R	
7C	B	
9C	O	
10C	L	
11C	R	
12C	O	

Connector No.	M2
Connector Name	FUSE BLOCK (J/B)
Connector Type	NS10PW-CS



Terminal No.	Color of Wire	Signal Name [Specification]
3B	P	
4B	G	
5B	O	
6B	Y	
7B	P	
8B	R	
9B	SB	

JCLWA3770GB

REAR WINDOW DEFOGGER SYSTEM

< DTC/CIRCUIT DIAGNOSIS >

DEFOGGER

Connector No.	M5
Connector Name	WIRE TO WIRE
Connector Type	TH80MW-CS1.5

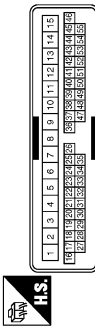

Terminal No.	Color of Wire	Signal Name [Specification]
3	BR	-
4	P	-
5	L	-
6	R	-
7	R	-
8	W	-
9	G	-
10	L	-
11	G	-
12	V	-
13	B	-
14	Y	-
15	W	-
16	R	-
17	B	-
18	G	-
19	Y	-
20	L	-
21	LG	-
22	L	-
23	G	-
24	Y	-
25	GR	-
26	R	-
27	W	-
28	SHIELD	-
29	Y	-
30	Y	-
31	R	-
32	BR	-
33	SB	-
34	Y	-
35	P	-
36	LG	-
37	BR	-
38	P	-
39	O	-
40	SB	-

41	L	-
42	R	-
43	BR	-
44	V	-
45	G	-
46	SB	- [With automatic drive positioner]
46	V	- [Without automatic drive positioner]
49	P	-
50	B	-
52	R	-
53	V	-
54	LG	-
55	SB	-

Connector No.	M6
Connector Name	WIRE TO WIRE
Connector Type	TH80MW-CS1F-TM4

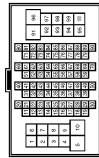

Terminal No.	Color of Wire	Signal Name [Specification]
1	W	-
2	R	-
3	B	-
4	SHIELD	-
5	G	-
8	Y	-
9	BR	-
10	R	-
11	BR	-
12	O	-
13	L	-
14	R	-
15	P	-
16	V	-
17	SB	-
18	V	-
20	O	-
21	L	-
22	W	-
23	P	-
24	BR	-
25	Y	-
26	V	-

27	G	-
28	G	-
31	L	-
32	G	-
33	B	-
34	W	-
35	R	-
36	SHIELD	-
37	V	-
38	O	-
39	BR	-
41	W	-
42	O	-
43	O	-
45	W	-
49	L	-
50	P	-
51	BR	-
52	L	-
53	P	-
54	Y	-
56	BR	-
57	G	-
59	W	-
60	L	-
61	G	-
62	SB	-
63	G	-
64	B	-
65	W	-
66	R	-
67	SHIELD	-
68	Y	-
69	GR	-
70	LG	-
71	LG	-
72	Y	-
73	SB	-
74	BR	-
74	L	-
75	G	-
76	W	-
76	G	-
76	GR	-
77	R	-
77	P	-
78	L	-
78	R	-
79	Y	-
79	W	-
80	SB	-
81	SB	-
82	SB	-

83	V	-
84	G	-
85	L	-
86	P	-
87	W	-
89	GR	-
90	SHIELD	-
91	W	-
92	Y	-
93	BR	-
94	P	-
95	GR	-
96	W	-
97	L	-
98	SHIELD	-
99	V	-
100	SB	-

Connector No.	M24
Connector Name	DATA LINK CONNECTOR
Connector Type	BD16FW

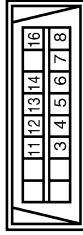

Terminal No.	Color of Wire	Signal Name [Specification]
3	G	-
4	B	-
5	B	-
6	L	-
7	V	-
8	G	-
11	R	-
14	P	-
16	Y	-

JCLWA3771GB

A
B
C
D
E
F
G
H
I
J
K
DEF
M
N
O
P

REAR WINDOW DEFOGGER SYSTEM

< DTC/CIRCUIT DIAGNOSIS >

DEFOGGER

Connector No.	M72
Connector Name	MULTIFUNCTION SWITCH
Connector Type	TH10FW-NH

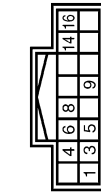

Terminal No.	Color of Wire	Signal Name [Specification]
1	B	GND
2	V	ACC
3	R	ILL
4	R	ILL CONT
5	Y	AV COMM (H)
6	LG	AV COMM (L)
7	V	SW GND
8	V	DISK EJECT SIGNAL
9	B	HAZARD ON
14	Y	HAZARD ON
16	G	HAZARD ON

Connector No.	M118
Connector Name	BCM (BODY CONTROL MODULE)
Connector Type	M03PE-LC



Terminal No.	Color of Wire	Signal Name [Specification]
1	W	BAT (7/L)
2	W	POWER WINDOW POWER SUPPLY (BAT)
3	Y	POWER WINDOW POWER SUPPLY (PAF)

Connector No.	M119
Connector Name	BCM (BODY CONTROL MODULE)
Connector Type	NS10FW-CS

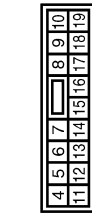

Terminal No.	Color of Wire	Signal Name [Specification]
4	LG	INTERIOR ROOM LAMP POWER SUPPLY
5	L	PASSENGER DOOR UNLOCK OUTPUT
7	Y	STEP LAMP OUTPUT
8	V	ALL DOOR FUEL LID LOCK OUTPUT
9	G	DRIVER DOOR FUEL LID UNLOCK OUTPUT
10	BR	REAR DOOR UNLOCK OUTPUT
11	R	BAT (FUSE)
13	B	GND
14	W	PUSH-BUTTON IGNITION SW ILL GND
15	Y	ACC IND
17	W	TURN SIGNAL RH (FRONT)
18	O	TURN SIGNAL LH (FRONT)
19	V	ROOM LAMP-TIMER CONTROL

Connector No.	M122
Connector Name	BCM (BODY CONTROL MODULE)
Connector Type	TH40FB-NH

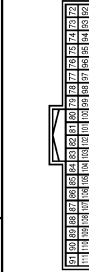

Terminal No.	Color of Wire	Signal Name [Specification]
72	R	ROOM ANT2-
73	G	ROOM ANT2+
74	SB	PASSENGER DOOR ANT-
75	GR	PASSENGER DOOR ANT+
76	V	DRIVER DOOR ANT-
77	LG	DRIVER DOOR ANT+
78	Y	ROOM ANT1-
79	BR	ROOM ANT1+
80	GR	NATS ANT AMP

81	W	NATS ANT AMP
82	R	IGN RELAY (F/B) CONT
83	Y	KEYLESS ENTRY RECEIVER COMM
87	BR	COMBI SW INPUT 5
88	V	COMBI SW INPUT 3
89	BR	PUSH SW
90	P	CAN-L
91	L	CAN-H
92	LG	KEY SLOT ILL
93	V	IGN IND
94	Y	PUDDLE LAMP CONT
95	O	A/T SHIFT SELECTOR POWER SUPPLY
96	GR	A/T SHIFT SELECTOR POWER SUPPLY
97	L	S/L CONDITION 1
98	P	S/L CONDITION 2
99	R	SHIFT P
100	G	PASSENGER DOOR REQUEST SW
101	SB	DRIVER DOOR REQUEST SW
102	O	BLOWER FAN MOTOR RELAY CONT
103	LG	KEYLESS ENTRY RECEIVER POWER SUPPLY
106	W	S/L UNIT POWER SUPPLY
107	LG	COMBI SW INPUT 1
108	R	COMBI SW INPUT 4
109	Y	COMBI SW INPUT 2
110	G	HAZARD SW
111	Y	S/L UNIT COMM

Connector No.	M123
Connector Name	BCM (BODY CONTROL MODULE)
Connector Type	TH40FG-NH

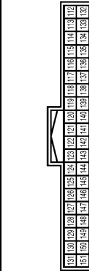

Terminal No.	Color of Wire	Signal Name [Specification]
113	P	OPTICAL SENSOR
116	SB	STOP LAMP SW 1
118	P	STOP LAMP SW 2
119	SB	DR DOOR UNLOCK SENSOR
121	BR	KEY SLOT SW
123	W	IGN F/B
124	LG	PASSENGER DOOR SW
132	BR	POWER WINDOW SW COMM
133	W	PUSH-BUTTON IGNITION SW ILL POWER
134	GR	LOCK IND

137	O	RECEIVER/SENSOR GND
138	Y	RECEIVER/SENSOR POWER SUPPLY
139	L	TIRE PRESSURE RECEIVER COMM
140	GR	SHIFT N/P
141	G	SECURITY INDICATOR OUTPUT
142	O	COMBI SW OUTPUT 5
143	P	COMBI SW OUTPUT 1
144	G	COMBI SW OUTPUT 2
145	L	COMBI SW OUTPUT 3
146	SB	COMBI SW OUTPUT 4
149	W	TIRE PRESS WARNING CHECK SW
150	LG	DRIVER DOOR SW
151	G	REAR WINDOW DEFOGGER RELAY CONT

REAR WINDOW DEFOGGER SYSTEM

< DTC/CIRCUIT DIAGNOSIS >

DEFOGGER

Connector No.	M124
Connector Name	WIRE TO WIRE
Connector Type	TH40MF-C315

1	2	3	4	5	6	7	8	9	10	11	12	13	14	15
81	82	83	84	85	86	87	88	89	90	91	92	93	94	95



Terminal No.	Color of Wire	Signal Name [Specification]
7	Y	-
8	LG	-
9	Y	-
12	L	-
13	V	-
14	B	-
15	W	-
18	R	-
19	B	-
20	Y	- [With BOSE audio]
20	W	- [Without BOSE audio]
21	G	- [With BOSE audio]
21	L	- [Without BOSE audio]
22	SB	-
23	GR	-
24	G	-
25	Y	-
26	R	-
29	SHIELD	-
30	W	-
31	LG	-
32	G	-
33	BR	-
34	V	-
35	G	-
43	L	-
44	Y	-
45	R	-
46	W	-
52	R	-
53	G	-
54	W	-
55	O	-

Connector No.	M202
Connector Name	AV CONTROL UNIT
Connector Type	TH42FW-NH

36	37	38	39	40	41	42	43	44	45	46	47
48	49	50	51	52	53	54	55	56	57	58	59



Terminal No.	Color of Wire	Signal Name [Specification]
36	O	SIGNAL VCC
37	LG	SIGNAL GND
38	R	HP
39	BR	COMM (DISP->CONT)
40	B	RGB AREA (YS) SIGNAL
41	SHIELD	SHIELD
42	W	RGB SYNC
43	G	RGB (RRED) SIGNAL
44	L	RGB (GREEN) SIGNAL
45	P	RGB (BLUE) SIGNAL
46	V	COMPOSITE IMAGE SIGNAL GND
47	SB	COMPOSITE IMAGE SIGNAL
48	V	INVERTER VCC
49	BR	INVERTER GND
50	G	VP
51	Y	COMM (CONT->DISP)
52	SHIELD	SHIELD
57	SHIELD	SHIELD
58	SHIELD	SHIELD

Connector No.	M204
Connector Name	AV CONTROL UNIT
Connector Type	TH43FW-NH

61	62	63	64	65	66	67	68	69	70	71	72	73	74	75	76	77	78	79	80	81	82	83	84	85	86	87	88	89	90	91	92
----	----	----	----	----	----	----	----	----	----	----	----	----	----	----	----	----	----	----	----	----	----	----	----	----	----	----	----	----	----	----	----



Terminal No.	Color of Wire	Signal Name [Specification]
76	P	AV COMM (L) [With base audio and hands-free phone]
76	B	AV COMM (L) [With base audio without hands-free phone]
76	Y	AV COMM (L) [With BOSE audio]

Terminal No.	Color of Wire	Signal Name [Specification]
77	G	AV COMM (H) [Except for base audio and hands-free phone]
77	L	AV COMM (H) [With base audio and hands-free phone]
78	B	AV COMM (L)
79	G	AV COMM (H)
80	P	CAN-L
81	L	CAN-H
82	B	SW GND
86	SHIELD	SHIELD
87	L	TEL VOICE SIGNAL (+)
88	P	TEL VOICE SIGNAL (-)
92	R	VEHICLE SPEED SIGNAL (8-PULSE)
93	V	PARKING BRAKE SIGNAL
94	O	REVERSE SIGNAL
95	G	IGNITION SIGNAL
96	Y	DISK EJECT SIGNAL
102	B	AUX SOUND SIGNAL GND
103	W	AUX SOUND SIGNAL LH (+)
104	R	AUX SOUND SIGNAL RH (+)

Connector No.	M210
Connector Name	AV CONTROL UNIT
Connector Type	TH432FW-NH



61	62	63	64	65	66	67	68	69	70	71	72	73	74	75	76	77	78	79	80	81	82	83	84	85	86	87	88	89	90	91	92
----	----	----	----	----	----	----	----	----	----	----	----	----	----	----	----	----	----	----	----	----	----	----	----	----	----	----	----	----	----	----	----

Terminal No.	Color of Wire	Signal Name [Specification]
65	V	PARKING BRAKE SIGNAL
67	G	COMPOSITE IMAGE SIGNAL GND
68	R	COMPOSITE IMAGE SIGNAL
71	SHIELD	MICROPHONE SHIELD
72	R	MICROPHONE VCC
73	R	COMM (CONT->DISP)
74	P	CAN-L
75	B	AV COMM (L)
76	Y	AV COMM (L)
79	R	ILLUMINATION
80	G	IGNITION SIGNAL
81	O	REVERSE SIGNAL
82	R	VEHICLE SPEED SIGNAL (8-PULSE)
83	SHIELD	SHIELD
87	G	MICROPHONE SIGNAL
88	SHIELD	SHIELD
89	G	COMM (DISP->CONT)
90	L	CAN-H

91	G	AV COMM (H)
92	G	AV COMM (H)

A
B
C
D
E
F
G
H
I
J
K
L
M
N
O
P

DEF

JCLWA3773GB

BCM (BODY CONTROL MODULE)

< ECU DIAGNOSIS INFORMATION >

ECU DIAGNOSIS INFORMATION

BCM (BODY CONTROL MODULE)

Reference Value

INFOID:00000000557261

VALUES ON THE DIAGNOSIS TOOL

CONSULT-III MONITOR ITEM

Monitor Item	Condition	Value/Status
FR WIPER HI	Other than front wiper switch HI	Off
	Front wiper switch HI	On
FR WIPER LOW	Other than front wiper switch LO	Off
	Front wiper switch LO	On
FR WASHER SW	Front washer switch OFF	Off
	Front washer switch ON	On
FR WIPER INT	Other than front wiper switch INT	Off
	Front wiper switch INT	On
FR WIPER STOP	Front wiper is not in STOP position	Off
	Front wiper is in STOP position	On
INT VOLUME	Wiper intermittent dial is in a dial position 1 - 7	Wiper intermittent dial position
RR WIPER ON	Other than rear wiper switch ON	Off
	Rear wiper switch ON	On
RR WIPER INT	Other than rear wiper switch INT	Off
	Rear wiper switch INT	On
RR WASHER SW	Rear washer switch OFF	Off
	Rear washer switch ON	On
RR WIPER STOP	Rear wiper is in STOP position	Off
	Rear wiper is not in STOP position	On
TURN SIGNAL R	Other than turn signal switch RH	Off
	Turn signal switch RH	On
TURN SIGNAL L	Other than turn signal switch LH	Off
	Turn signal switch LH	On
TAIL LAMP SW	Other than lighting switch 1ST and 2ND	Off
	Lighting switch 1ST or 2ND	On
HI BEAM SW	Other than lighting switch HI	Off
	Lighting switch HI	On
HEAD LAMP SW 1	Other than lighting switch 2ND	Off
	Lighting switch 2ND	On
HEAD LAMP SW 2	Other than lighting switch 2ND	Off
	Lighting switch 2ND	On
PASSING SW	Other than lighting switch PASS	Off
	Lighting switch PASS	On
AUTO LIGHT SW	Other than lighting switch AUTO	Off
	Lighting switch AUTO	On
FR FOG SW	Front fog lamp switch OFF	Off
	Front fog lamp switch ON	On

BCM (BODY CONTROL MODULE)

< ECU DIAGNOSIS INFORMATION >

Monitor Item	Condition	Value/Status	
RR FOG SW	NOTE: The item is indicated, but not monitored.	Off	A
DOOR SW-DR	Driver door closed	Off	B
	Driver door opened	On	
DOOR SW-AS	Passenger door closed	Off	C
	Passenger door opened	On	
DOOR SW-RR	Rear RH door closed	Off	D
	Rear RH door opened	On	
DOOR SW-RL	Rear LH door closed	Off	D
	Rear LH door opened	On	
DOOR SW-BK	Back door closed	Off	E
	Back door opened	On	
CDL LOCK SW	Other than power door lock switch LOCK	Off	F
	Power door lock switch LOCK	On	
CDL UNLOCK SW	Other than power door lock switch UNLOCK	Off	G
	Power door lock switch UNLOCK	On	
KEY CYL LK-SW	Other than driver door key cylinder LOCK position	Off	H
	Driver door key cylinder LOCK position	On	
KEY CYL UN-SW	Other than driver door key cylinder UNLOCK position	Off	H
	Driver door key cylinder UNLOCK position	On	
KEY CYL SW-TR	NOTE: The item is indicated, but not monitored.	Off	I
HAZARD SW	Hazard switch is OFF	Off	J
	Hazard switch is ON	On	
REAR DEF SW	NOTE: The item is indicated, but not monitored.	Off	K
TR CANCEL SW	NOTE: The item is indicated, but not monitored.	Off	K
TR/BD OPEN SW	Back door opener switch OFF	Off	DEF
	While the back door opener switch is turned ON	On	
TRNK/HAT MNTR	NOTE: The item is indicated, but not monitored.	Off	M
RKE-LOCK	LOCK button of the key is not pressed	Off	M
	LOCK button of the key is pressed	On	
RKE-UNLOCK	UNLOCK button of the key is not pressed	Off	N
	UNLOCK button of the key is pressed	On	
RKE-TR/BD	NOTE: The item is indicated, but not monitored.	Off	O
RKE-PANIC	PANIC button of the key is not pressed	Off	O
	PANIC button of the key is pressed	On	
RKE-P/W OPEN	UNLOCK button of the key is not pressed	Off	P
	UNLOCK button of the key is pressed and held	On	
RKE-MODE CHG	LOCK/UNLOCK button of the key is not pressed and held simultaneously	Off	P
	LOCK/UNLOCK button of the key is pressed and held simultaneously	On	

BCM (BODY CONTROL MODULE)

< ECU DIAGNOSIS INFORMATION >

Monitor Item	Condition	Value/Status
OPTICAL SENSOR	Bright outside of the vehicle	Close to 5 V
	Dark outside of the vehicle	Close to 0 V
REQ SW -DR	Driver door request switch is not pressed	Off
	Driver door request switch is pressed	On
REQ SW -AS	Passenger door request switch is not pressed	Off
	Passenger door request switch is pressed	On
REQ SW -RR	NOTE: The item is indicated, but not monitored.	Off
REQ SW -RL	NOTE: The item is indicated, but not monitored.	Off
REQ SW -BD/TR	Back door request switch is not pressed	Off
	Back door request switch is pressed	On
PUSH SW	Push-button ignition switch (push switch) is not pressed	Off
	Push-button ignition switch (push switch) is pressed	On
IGN RLY2 -F/B	Ignition switch in OFF or ACC position	Off
	Ignition switch in ON position	On
ACC RLY -F/B	NOTE: The item is indicated, but not monitored.	Off
CLUCH SW	NOTE: The item is indicated, but not monitored.	Off
BRAKE SW 1	The brake pedal is depressed when No. 7 fuse is blown	Off
	The brake pedal is not depressed when No. 7 fuse is blown, or No. 7 fuse is normal	On
BRAKE SW 2	The brake pedal is not depressed	Off
	The brake pedal is depressed	On
DETE/CANCL SW	Selector lever in P position	Off
	Selector lever in any position other than P	On
SFT PN/N SW	Selector lever in any position other than P and N	Off
	Selector lever in P or N position	On
S/L -LOCK	Steering is unlocked	Off
	Steering is locked	On
S/L -UNLOCK	Steering is locked	Off
	Steering is unlocked	On
S/L RELAY-F/B	Ignition switch in OFF or ACC position	Off
	Ignition switch in ON position	On
UNLK SEN -DR	Driver door is unlocked	Off
	Driver door is locked	On
PUSH SW -IPDM	Push-button ignition switch (push-switch) is not pressed	Off
	Push-button ignition switch (push-switch) is pressed	On
IGN RLY1 -F/B	Ignition switch in OFF or ACC position	Off
	Ignition switch in ON position	On
DETE SW -IPDM	Selector lever in any position other than P	Off
	Selector lever in P position	On
SFT PN -IPDM	Selector lever in any position other than P and N	Off
	Selector lever in P or N position	On

BCM (BODY CONTROL MODULE)

< ECU DIAGNOSIS INFORMATION >

Monitor Item	Condition	Value/Status	
SFT P -MET	Selector lever in any position other than P	Off	A
	Selector lever in P position	On	
SFT N -MET	Selector lever in any position other than N	Off	B
	Selector lever in N position	On	
ENGINE STATE	Engine stopped	Stop	
	While the engine stalls	Stall	C
	At engine cranking	Crank	
	Engine running	Run	D
S/L LOCK-IPDM	Steering is unlocked	Off	
	Steering is locked	On	
S/L UNLK-IPDM	Steering is locked	Off	E
	Steering is unlocked	On	
S/L RELAY-REQ	Steering lock system is not the LOCK condition and the changing condition from LOCK to UNLOCK.	Off	F
	Steering lock system is the LOCK condition or the changing condition from LOCK to UNLOCK.	On	
VEH SPEED 1	While driving	Equivalent to speedometer reading	G
VEH SPEED 2	While driving	Equivalent to speedometer reading	
DOOR STAT-DR	Driver door is locked	LOCK	H
	Wait with selective UNLOCK operation (5 seconds)	READY	
	Driver door is unlocked	UNLOCK	
DOOR STAT-AS	Passenger door is locked	LOCK	I
	Wait with selective UNLOCK operation (5 seconds)	READY	
	Passenger door is unlocked	UNLOCK	J
ID OK FLAG	Steering is locked	Reset	
	Steering is unlocked	Set	
PRMT ENG STRT	The engine start is prohibited	Reset	K
	The engine start is permitted	Set	
PRMT RKE STRT	NOTE: The item is indicated, but not monitored.	Reset	DEF
KEY SW -SLOT	The key is not inserted into key slot	Off	
	The key is inserted into key slot	On	M
RKE OPE COUN1	During the operation of the key	Operation frequency of the key	
RKE OPE COUN2	NOTE: The item is indicated, but not monitored.	—	N
CONFIRM ID ALL	The key ID that the key slot receives does not accord with any key ID registered to BCM.	Yet	
	The key ID that the key slot receives accords with any key ID registered to BCM.	Done	O
CONFIRM ID4	The key ID that the key slot receives does not accord with the fourth key ID registered to BCM.	Yet	
	The key ID that the key slot receives accords with the fourth key ID registered to BCM.	Done	P
CONFIRM ID3	The key ID that the key slot receives does not accord with the third key ID registered to BCM.	Yet	
	The key ID that the key slot receives accords with the third key ID registered to BCM.	Done	

BCM (BODY CONTROL MODULE)

< ECU DIAGNOSIS INFORMATION >

Monitor Item	Condition	Value/Status
CONFIRM ID2	The key ID that the key slot receives does not accord with the second key ID registered to BCM.	Yet
	The key ID that the key slot receives accords with the second key ID registered to BCM.	Done
CONFIRM ID1	The key ID that the key slot receives does not accord with the first key ID registered to BCM.	Yet
	The key ID that the key slot receives accords with the first key ID registered to BCM.	Done
TP 4	The ID of fourth key is not registered to BCM	Yet
	The ID of fourth key is registered to BCM	Done
TP 3	The ID of third key is not registered to BCM	Yet
	The ID of third key is registered to BCM	Done
TP 2	The ID of second key is not registered to BCM	Yet
	The ID of second key is registered to BCM	Done
TP 1	The ID of first key is not registered to BCM	Yet
	The ID of first key is registered to BCM	Done
AIR PRESS FL	Ignition switch ON (Only when the signal from the transmitter is received)	Air pressure of front LH tire
AIR PRESS FR	Ignition switch ON (Only when the signal from the transmitter is received)	Air pressure of front RH tire
AIR PRESS RR	Ignition switch ON (Only when the signal from the transmitter is received)	Air pressure of rear RH tire
AIR PRESS RL	Ignition switch ON (Only when the signal from the transmitter is received)	Air pressure of rear LH tire
ID REGST FL1	ID of front LH tire transmitter is registered	Done
	ID of front LH tire transmitter is not registered	Yet
ID REGST FR1	ID of front RH tire transmitter is registered	Done
	ID of front RH tire transmitter is not registered	Yet
ID REGST RR1	ID of rear RH tire transmitter is registered	Done
	ID of rear RH tire transmitter is not registered	Yet
ID REGST RL1	ID of rear LH tire transmitter is registered	Done
	ID of rear LH tire transmitter is not registered	Yet
WARNING LAMP	Tire pressure indicator OFF	Off
	Tire pressure indicator ON	On
BUZZER	Tire pressure warning alarm is not sounding	Off
	Tire pressure warning alarm is sounding	On

BCM (BODY CONTROL MODULE)

< ECU DIAGNOSIS INFORMATION >

TERMINAL LAYOUT

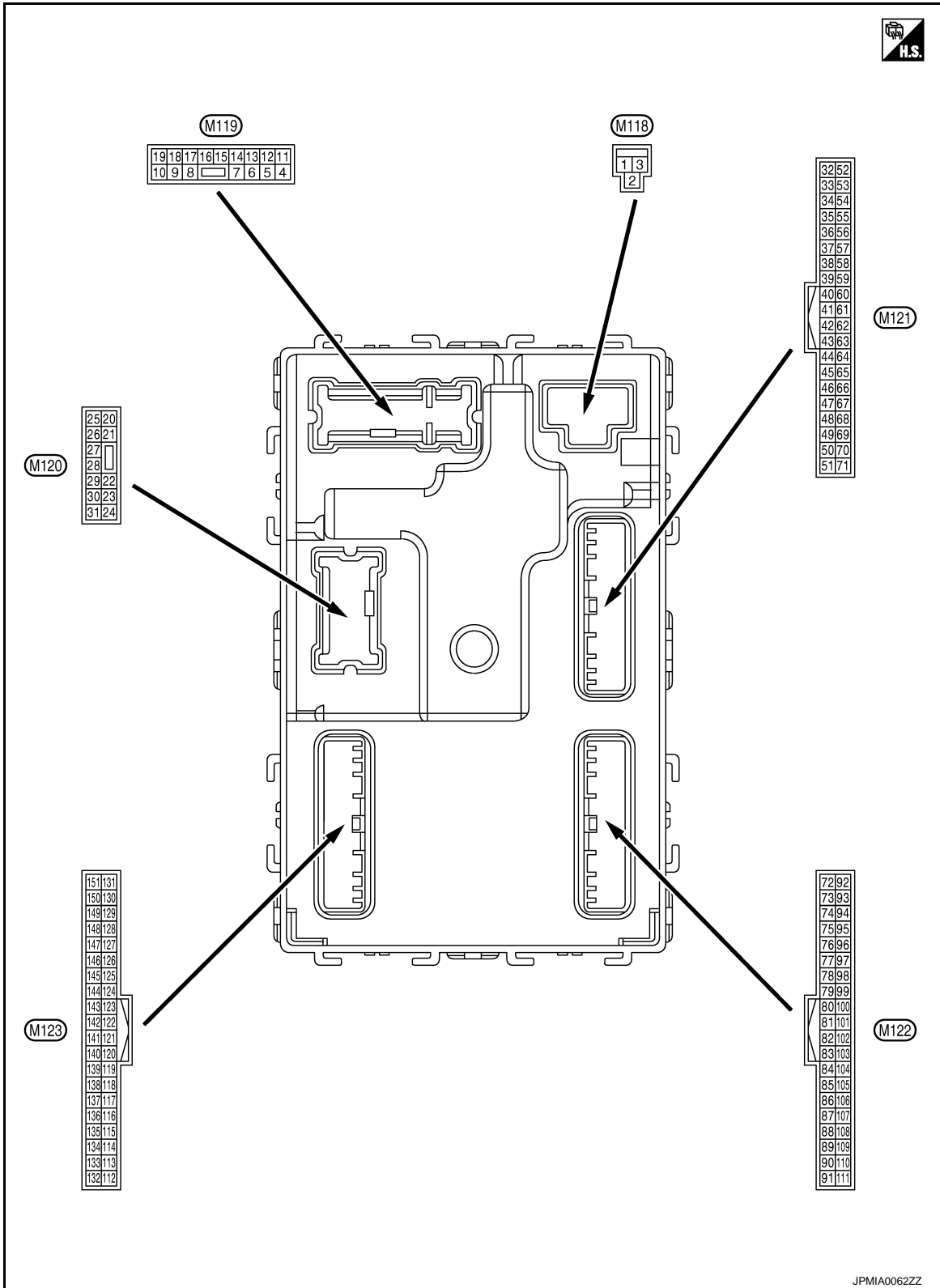

A
B
C
D
E
F
G
H
I
J
K
DEF
M
N
O
P

PHYSICAL VALUES

BCM (BODY CONTROL MODULE)

< ECU DIAGNOSIS INFORMATION >

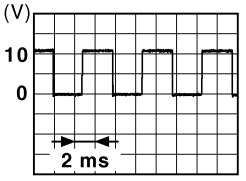
Terminal No. (Wire color)		Description		Condition		Value (Approx.)
		Signal name	Input/ Output			
+	-					
1 (W)	Ground	Battery power supply	Input	Ignition switch OFF		Battery voltage
2 (W)	Ground	P/W power supply (BAT)	Output	Ignition switch OFF		Battery voltage
3 (Y)	Ground	P/W power supply (RAP)	Output	Ignition switch ON		Battery voltage
4 (LG)	Ground	Interior room lamp power supply	Output	Interior room lamp battery saver is activated. (Cuts the interior room lamp power supply)		0 V
				Interior room lamp battery saver is not activated. (Outputs the interior room lamp power supply)		Battery voltage
5 (L)	Ground	Passenger door UN- LOCK	Output	Passenger door	UNLOCK (Actuator is activated)	Battery voltage
					Other than UNLOCK (Actuator is not activated)	0 V
7 (Y)	Ground	Step lamp	Output	Step lamp	ON	0 V
					OFF	Battery voltage
8 (V)	Ground	All doors, fuel lid LOCK	Output	All doors	LOCK (Actuator is activated)	Battery voltage
					Other than LOCK (Actuator is not activated)	0 V
9 (G)	Ground	Driver door, fuel lid UNLOCK	Output	Driver door	UNLOCK (Actuator is activated)	Battery voltage
					Other than UNLOCK (Actuator is not activated)	0 V
10 (BR)	Ground	Rear RH door and rear LH door UN- LOCK	Output	Rear RH door and rear LH door	UNLOCK (Actuator is activated)	Battery voltage
					Other than UNLOCK (Actuator is not activated)	0 V
11 (R)	Ground	Battery power supply	Input	Ignition switch OFF		Battery voltage
13 (B)	Ground	Ground	—	Ignition switch ON		0 V
14 (W)	Ground	Push-button ignition switch illumination ground	Output	Tail lamp	OFF	0 V
					ON	<p>NOTE: When the illumination brightening/dimming level is in the neutral position</p>  <p style="text-align: right; font-size: small;">JSNIA0010GB</p>
15 (Y)	Ground	ACC indicator lamp	Output	Ignition switch	OFF or ON	Battery voltage
					ACC	0 V

BCM (BODY CONTROL MODULE)

< ECU DIAGNOSIS INFORMATION >

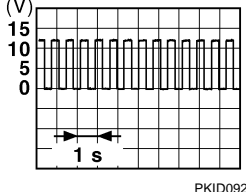
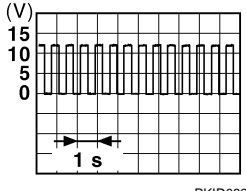
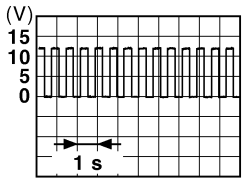
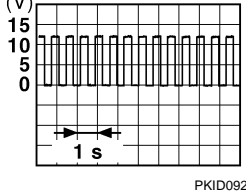
Terminal No. (Wire color)		Description		Condition	Value (Approx.)
+	-	Signal name	Input/ Output		
17 (W)	Ground	Turn signal RH (Front)	Output	Ignition switch ON	Turn signal switch OFF 0 V
				Turn signal switch RH	 6.5 V
18 (O)	Ground	Turn signal LH (Front)	Output	Ignition switch ON	Turn signal switch OFF 0 V
				Turn signal switch LH	 6.5 V
19 (V)	Ground	Room lamp timer control	Output	Interior room lamp	OFF Battery voltage
				ON	0 V
20 (V)	Ground	Turn signal RH (Rear)	Output	Ignition switch ON	Turn signal switch OFF 0 V
				Turn signal switch RH	 6.5 V
23 (G)	Ground	Back door open	Output	Back door	OPEN (Back door opener actuator is activated) Battery voltage
				Other than OPEN (Back door opener actuator is not activated)	0 V
25 (G)	Ground	Turn signal LH (Rear)	Output	Ignition switch ON	Turn signal switch OFF 0 V
				Turn signal switch LH	 6.5 V
26 (G)	Ground	Rear wiper	Output	Rear wiper	OFF (Stopped) 0 V
				ON (Operated)	Battery voltage

BCM (BODY CONTROL MODULE)

< ECU DIAGNOSIS INFORMATION >

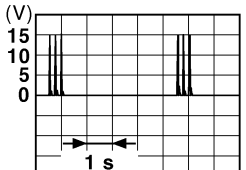
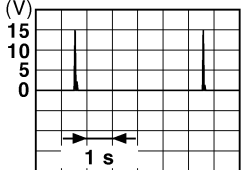
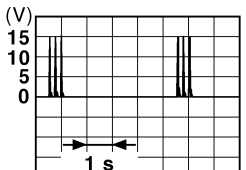
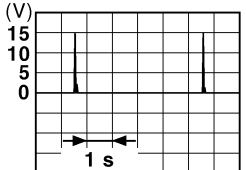
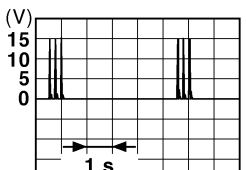
Terminal No. (Wire color)		Description		Condition	Value (Approx.)
+	-	Signal name	Input/ Output		
34 (SB)	Ground	Luggage room antenna (-)	Output		
				When Intelligent Key is not in the passenger compartment	 <p style="text-align: right; font-size: small;">JMKIA0063GB</p>
35 (V)	Ground	Luggage room antenna (+)	Output	Ignition switch OFF	 <p style="text-align: right; font-size: small;">JMKIA0062GB</p>
				When Intelligent Key is not in the passenger compartment	 <p style="text-align: right; font-size: small;">JMKIA0063GB</p>
38 (B)	Ground	Back door antenna (-)	Output	When the back door opener request switch is operated with ignition switch OFF	 <p style="text-align: right; font-size: small;">JMKIA0062GB</p>
				When Intelligent Key is not in the antenna detection area	 <p style="text-align: right; font-size: small;">JMKIA0063GB</p>

BCM (BODY CONTROL MODULE)

< ECU DIAGNOSIS INFORMATION >

Terminal No. (Wire color)		Description		Condition	Value (Approx.)
+	-	Signal name	Input/ Output		
39 (W)	Ground	Back door antenna (+)	Output	When Intelligent Key is in the antenna detection area	
				When Intelligent Key is not in the antenna detection area	
47 (Y)	Ground	Ignition relay (IPDM E/R) control	Output	Ignition switch	OFF or ACC Battery voltage
				ON	0 V
52 (SB)	Ground	Starter relay control	Output	Ignition switch ON	When selector lever is in P or N position Battery voltage
				When selector lever is not in P or N position	0 V
61 (W)	Ground	Back door opener re- quest switch	Input	Back door opener request switch	ON (Pressed) 0 V
				OFF (Not pressed)	
64 (V)	Ground	Intelligent Key warn- ing buzzer (Engine room)	Output	Intelligent Key warning buzzer (Engine room)	Sounding 0 V
				Not sounding	Battery voltage
65 (O)	Ground	Rear wiper stop posi- tion	Input	Rear wiper	In stop position
				Not in stop position	
					0 V

A
B
C
D
E
F
G
H
I
J
K
DEF
M
N
O
P

BCM (BODY CONTROL MODULE)

< ECU DIAGNOSIS INFORMATION >

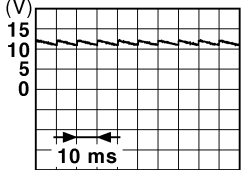
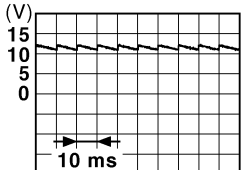
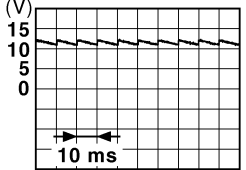
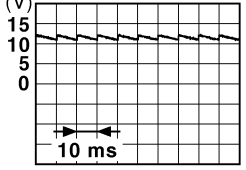
Terminal No. (Wire color)		Description		Condition	Value (Approx.)	
+	-	Signal name	Input/ Output			
66 (R)	Ground	Back door switch	Input	Back door switch	OFF (Door close)	 <small>JPMIA0011GB</small> 11.8 V
					ON (Door open)	0 V
67 (GR)	Ground	Back door opener switch	Input	Back door opener switch	Pressed	0 V
					Not pressed	 <small>JPMIA0011GB</small> 11.8 V
68 (BR)	Ground	Rear RH door switch	Input	Rear RH door switch	OFF (Door close)	 <small>JPMIA0011GB</small> 11.8 V
					ON (Door open)	0 V
69 (R)	Ground	Rear LH door switch	Input	Rear LH door switch	OFF (Door close)	 <small>JPMIA0011GB</small> 11.8 V
					ON (Door open)	0 V

BCM (BODY CONTROL MODULE)

< ECU DIAGNOSIS INFORMATION >

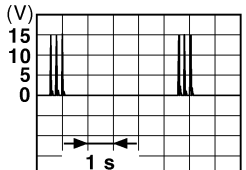
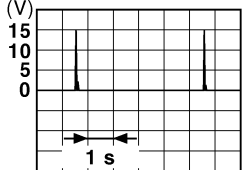
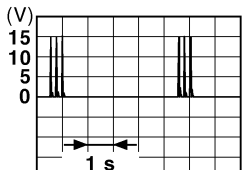
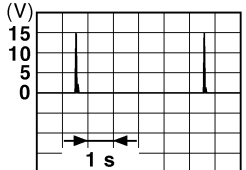
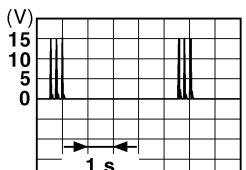
Terminal No. (Wire color)		Description		Condition	Value (Approx.)
+	-	Signal name	Input/ Output		
72 (R)	Ground	Room antenna 2 (-) (Center console)	Output		
				When Intelligent Key is not in the passenger compart- ment	 <p style="text-align: right; font-size: small;">JMKIA0063GB</p>
73 (G)	Ground	Room antenna 2 (+) (Center console)	Output	Ignition switch OFF	 <p style="text-align: right; font-size: small;">JMKIA0062GB</p>
				When Intelligent Key is not in the passenger compart- ment	 <p style="text-align: right; font-size: small;">JMKIA0063GB</p>
74 (SB)	Ground	Passenger door an- tenna (-)	Output	When the pas- senger door re- quest switch is operated with ig- nition switch OFF	 <p style="text-align: right; font-size: small;">JMKIA0062GB</p>
				When Intelligent Key is not in the antenna detection area	 <p style="text-align: right; font-size: small;">JMKIA0063GB</p>

A
B
C
D
E
F
G
H
I
J
K
DEF
M
N
O
P



BCM (BODY CONTROL MODULE)

< ECU DIAGNOSIS INFORMATION >

Terminal No. (Wire color)		Description		Condition	Value (Approx.)
+	-	Signal name	Input/ Output		
75 (GR)	Ground	Passenger door antenna (+)	Output	When Intelligent Key is in the antenna detection area	<p style="text-align: right; font-size: small;">JMKIA0062GB</p>
				When Intelligent Key is not in the antenna detection area	<p style="text-align: right; font-size: small;">JMKIA0063GB</p>
76 (V)	Ground	Driver door antenna (-)	Output	When Intelligent Key is in the antenna detection area	<p style="text-align: right; font-size: small;">JMKIA0062GB</p>
				When Intelligent Key is not in the antenna detection area	<p style="text-align: right; font-size: small;">JMKIA0063GB</p>
77 (LG)	Ground	Driver door antenna (+)	Output	When Intelligent Key is in the antenna detection area	<p style="text-align: right; font-size: small;">JMKIA0062GB</p>
				When Intelligent Key is not in the antenna detection area	<p style="text-align: right; font-size: small;">JMKIA0063GB</p>

BCM (BODY CONTROL MODULE)

< ECU DIAGNOSIS INFORMATION >

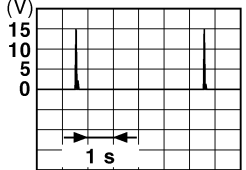
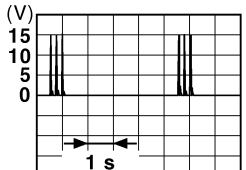
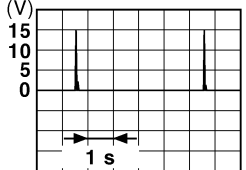
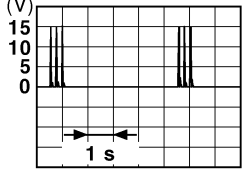



Terminal No. (Wire color)		Description		Condition	Value (Approx.)	
+	-	Signal name	Input/ Output			
78 (Y)	Ground	Room antenna 1 (-) (Instrument panel)	Output	Ignition switch OFF	 <p style="text-align: right; font-size: small;">JMKIA0062GB</p>	
				Ignition switch OFF	 <p style="text-align: right; font-size: small;">JMKIA0063GB</p>	
79 (BR)	Ground	Room antenna 1 (+) (Instrument panel)	Output	Ignition switch OFF	 <p style="text-align: right; font-size: small;">JMKIA0062GB</p>	
				Ignition switch OFF	 <p style="text-align: right; font-size: small;">JMKIA0063GB</p>	
80 (GR)	Ground	NATS antenna amp.	Input/ Output	During waiting	Ignition switch is pressed while inserting the key into the key slot. Just after pressing ignition switch. Pointer of tester should move.	
81 (W)	Ground	NATS antenna amp.	Input/ Output	During waiting	Ignition switch is pressed while inserting the key into the key slot. Just after pressing ignition switch. Pointer of tester should move.	
82 (R)	Ground	Ignition relay [Fuse block (J/B)] control	Output	Ignition switch	OFF or ACC	0 V
				ON	Battery voltage	

A
B
C
D
E
F
G
H
I
J
K
DEF
M
N
O
P

DEF

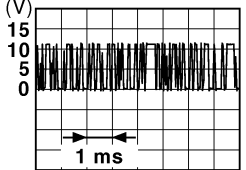
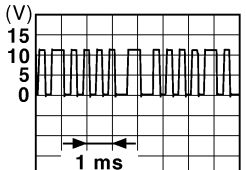

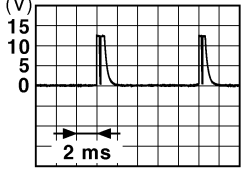
BCM (BODY CONTROL MODULE)

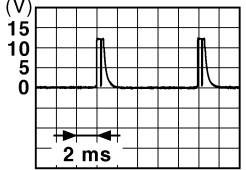
< ECU DIAGNOSIS INFORMATION >

Terminal No. (Wire color)		Description		Condition	Value (Approx.)
+	-	Signal name	Input/ Output		
83 (Y)	Ground	Remote keyless entry receiver communication	Input/ Output	During waiting	 <p style="text-align: right; font-size: small;">JMKIA0064GB</p>
				When operating either button on the key	 <p style="text-align: right; font-size: small;">JMKIA0065GB</p>
87 (BR)	Ground	Combination switch INPUT 5	Input	Combination switch	All switches OFF (Wiper intermittent dial 4)  <p style="text-align: right; font-size: small;">JPMIA0041GB</p> <p style="text-align: center;">1.4 V</p>
					Front fog lamp switch ON (Wiper intermittent dial 4)  <p style="text-align: right; font-size: small;">JPMIA0037GB</p> <p style="text-align: center;">1.3 V</p>
					Rear wiper switch ON (Wiper intermittent dial 4)  <p style="text-align: right; font-size: small;">JPMIA0039GB</p> <p style="text-align: center;">1.3 V</p>
					Any of the conditions below with all switches OFF <ul style="list-style-type: none"> • Wiper intermittent dial 1 • Wiper intermittent dial 2 • Wiper intermittent dial 6 • Wiper intermittent dial 7  <p style="text-align: right; font-size: small;">JPMIA0040GB</p> <p style="text-align: center;">1.3 V</p>

BCM (BODY CONTROL MODULE)

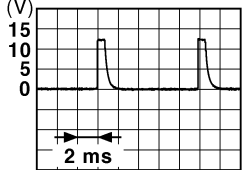
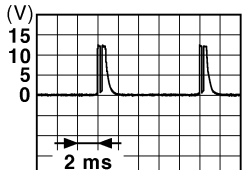
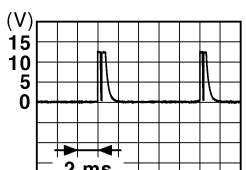
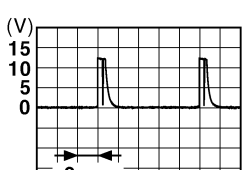
< ECU DIAGNOSIS INFORMATION >

Terminal No. (Wire color)		Description		Condition	Value (Approx.)	
+	-	Signal name	Input/ Output			
88 (V)	Ground	Combination switch INPUT 3	Input	Combination switch	All switches OFF (Wiper intermittent dial 4)	 <p style="text-align: right;">1.4 V</p>
					Lighting switch HI (Wiper intermittent dial 4)	 <p style="text-align: right;">1.3 V</p>
					Lighting switch 2ND (Wiper intermittent dial 4)	 <p style="text-align: right;">1.3 V</p>
					Rear washer switch ON (Wiper intermittent dial 4)	 <p style="text-align: right;">1.3 V</p>
					Any of the conditions below with all switches OFF	 <p style="text-align: right;">1.3 V</p>
89 (BR)	Ground	Push-button ignition switch (Push switch)	Input	Push-button igni- tion switch (push switch)	Pressed	0 V
				Not pressed	Battery voltage	
90 (P)	Ground	CAN-L	Input/ Output	—	—	
91 (L)	Ground	CAN-H	Input/ Output	—	—	

A
B
C
D
E
F
G
H
I
J
K
DEF
M
N
O
P

BCM (BODY CONTROL MODULE)

< ECU DIAGNOSIS INFORMATION >

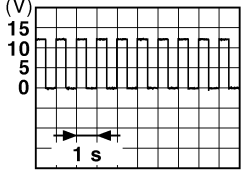
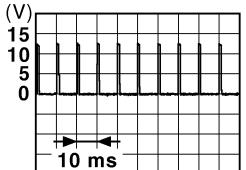
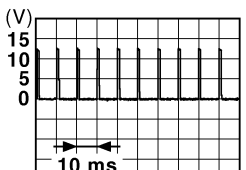
Terminal No. (Wire color)		Description		Condition	Value (Approx.)	
+	-	Signal name	Input/ Output			
92 (LG)	Ground	Key slot illumination	Output	Key slot illumination	OFF	Battery voltage
					Blinking	 <p style="text-align: center;">6.5 V</p>
93 (V)	Ground	ON indicator lamp	Output	Ignition switch	OFF or ACC	Battery voltage
					ON	0 V
94 (Y)	Ground	Puddle lamp control	Output	Puddle lamp	OFF	Battery voltage
					ON	0 V
95 (O)	Ground	ACC relay control	Output	Ignition switch	OFF	0 V
					ACC or ON	Battery voltage
96 (GR)	Ground	A/T shift selector (Detention switch) power supply	Output	—	Battery voltage	
97 (L)	Ground	Steering lock condition No. 1	Input	Steering lock	LOCK status	0 V
					UNLOCK status	Battery voltage
98 (P)	Ground	Steering lock condition No. 2	Input	Steering lock	LOCK status	Battery voltage
					UNLOCK status	0 V
99 (R)	Ground	Selector lever P position switch	Input	Selector lever	P position	0 V
					Any position other than P	Battery voltage
100 (G)	Ground	Passenger door request switch	Input	Passenger door request switch	ON (Pressed)	0 V
					OFF (Not pressed)	 <p style="text-align: center;">1.0 V</p>
101 (SB)	Ground	Driver door request switch	Input	Driver door request switch	ON (Pressed)	0 V
					OFF (Not pressed)	 <p style="text-align: center;">1.0 V</p>
102 (O)	Ground	Blower fan motor relay control	Output	Ignition switch	OFF or ACC	0 V
					ON	Battery voltage

BCM (BODY CONTROL MODULE)

< ECU DIAGNOSIS INFORMATION >

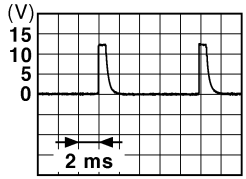
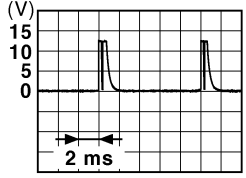
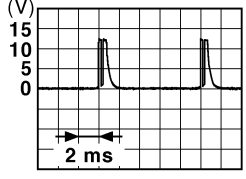
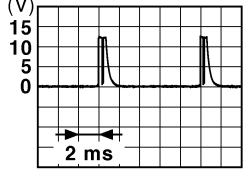
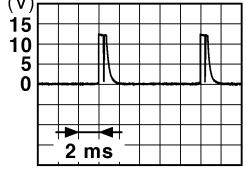
Terminal No. (Wire color)		Description		Condition	Value (Approx.)	
		Signal name	Input/ Output			
+	-					
103 (LG)	Ground	Remote keyless entry receiver power supply	Output	Ignition switch OFF	Battery voltage	
106 (W)	Ground	Steering lock unit power supply	Output	Ignition switch	OFF or ACC	
					ON	0 V
107 (LG)	Ground	Combination switch INPUT 1	Input	Combination switch (Wiper intermittent dial 4)	All switches OFF	 <p style="text-align: center;">1.4 V</p>
					Turn signal switch LH	 <p style="text-align: center;">1.3 V</p>
					Turn signal switch RH	 <p style="text-align: center;">1.3 V</p>
					Front wiper switch LO	 <p style="text-align: center;">1.3 V</p>
					Front washer switch ON	 <p style="text-align: center;">1.3 V</p>

A
B
C
D
E
F
G
H
I
J
K
DEF
M
N
O
P



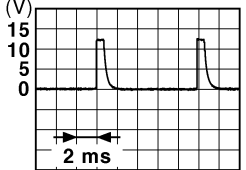
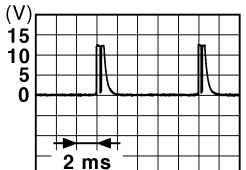
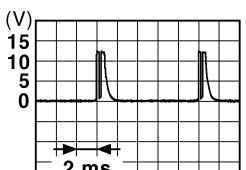
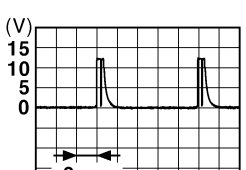
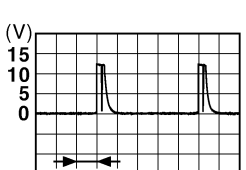

BCM (BODY CONTROL MODULE)

< ECU DIAGNOSIS INFORMATION >

Terminal No. (Wire color)		Description		Condition	Value (Approx.)	
		Signal name	Input/ Output			
+	-					
108 (R)	Ground	Combination switch INPUT 4	Input	Combination switch	All switches OFF (Wiper intermittent dial 4)	 <p style="text-align: right; font-size: small;">JPMA0041GB</p> <p style="text-align: center;">1.4 V</p>
					Lighting switch AUTO (Wiper intermittent dial 4)	 <p style="text-align: right; font-size: small;">JPMA0038GB</p> <p style="text-align: center;">1.3 V</p>
					Lighting switch 1ST (Wiper intermittent dial 4)	 <p style="text-align: right; font-size: small;">JPMA0036GB</p> <p style="text-align: center;">1.3 V</p>
					Rear wiper switch INT (Wiper intermittent dial 4)	 <p style="text-align: right; font-size: small;">JPMA0040GB</p> <p style="text-align: center;">1.3 V</p>
					Any of the conditions below with all switches OFF	<ul style="list-style-type: none"> • Wiper intermittent dial 1 • Wiper intermittent dial 5 • Wiper intermittent dial 6  <p style="text-align: right; font-size: small;">JPMA0039GB</p> <p style="text-align: center;">1.3 V</p>

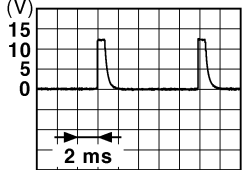
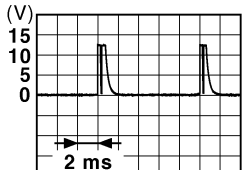
BCM (BODY CONTROL MODULE)

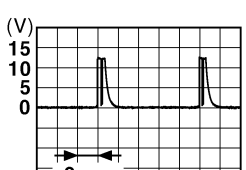
< ECU DIAGNOSIS INFORMATION >

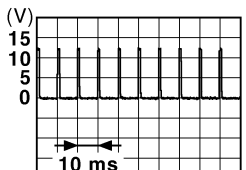
Terminal No. (Wire color)		Description		Condition	Value (Approx.)	
+	-	Signal name	Input/ Output			
109 (Y)	Ground	Combination switch INPUT 2	Input	Combination switch (Wiper intermit- tent dial 4)	All switches OFF	 <p style="text-align: right;">1.4 V</p>
					Lighting switch PASS	 <p style="text-align: right;">1.3 V</p>
					Lighting switch 2ND	 <p style="text-align: right;">1.3 V</p>
					Front wiper switch INT	 <p style="text-align: right;">1.3 V</p>
					Front wiper switch HI	 <p style="text-align: right;">1.3 V</p>
					ON	0 V
110 (G)	Ground	Hazard switch	Input	Hazard switch	 <p style="text-align: right;">1.1 V</p>	
				OFF		

A
B
C
D
E
F
G
H
I
J
K
DEF
M
N
O
P



BCM (BODY CONTROL MODULE)

< ECU DIAGNOSIS INFORMATION >

Terminal No. (Wire color)		Description		Condition	Value (Approx.)	
+	-	Signal name	Input/ Output			
111 (Y)	Ground	Steering lock unit communication	Input/ Output	Steering lock	LOCK status	Battery voltage
				LOCK or UNLOCK	<p style="text-align: right; font-size: small;">JMKIA0066GB</p>	
				For 15 seconds after UN- LOCK	Battery voltage	
				15 seconds or later after UNLOCK	0 V	
113 (P)	Ground	Optical sensor	Input	Ignition switch ON	When bright outside of the vehicle	Close to 5 V
				When dark outside of the vehicle	Close to 0 V	
116 (SB)	Ground	Stop lamp switch 1	Input	—	Battery voltage	
118 (P)	Ground	Stop lamp switch 2 (Without ICC)	Input	Stop lamp switch	OFF (Brake pedal is not depressed)	0 V
					ON (Brake pedal is de- pressed)	Battery voltage
		Stop lamp switch 2 (With ICC)		Stop lamp switch OFF (Brake pedal is not de- pressed) and ICC brake hold relay OFF	0 V	
				Stop lamp switch ON (Brake pedal is de- pressed) or ICC brake hold relay ON	Battery voltage	
119 (SB)	Ground	Front door lock as- sembly driver side (Unlock sensor)	Input	Driver door	LOCK status (Unlock sensor switch OFF)	<p style="text-align: right; font-size: small;">JPMIA0012GB</p>
					UNLOCK status (Unlock switch sensor ON)	0 V
					1.1 V	
121 (BR)	Ground	Key slot switch	Input	When the key is inserted into key slot	Battery voltage	
				When the key is not inserted into key slot	0 V	
123 (W)	Ground	IGN feedback	Input	Ignition switch	OFF or ACC	0 V
				ON	Battery voltage	

BCM (BODY CONTROL MODULE)

< ECU DIAGNOSIS INFORMATION >

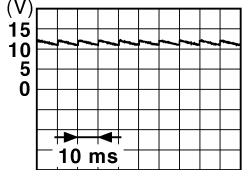
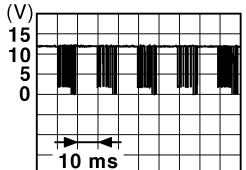
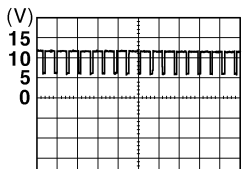
Terminal No. (Wire color)		Description		Condition		Value (Approx.)
+	-	Signal name	Input/ Output			
124 (LG)	Ground	Passenger door switch	Input	Passenger door switch	OFF (Door close)	 <p style="text-align: right; font-size: small;">JPMIA0011GB</p> <p style="text-align: center;">11.8 V</p>
					ON (Door open)	0 V
132 (BR)	Ground	Power window switch communication	Input/ Output	Ignition switch ON	 <p style="text-align: right; font-size: small;">JPMIA0013GB</p> <p style="text-align: center;">10.2 V</p>	
					Ignition switch OFF or ACC	Battery voltage
133 (W)	Ground	Push-button ignition switch illumination	Output	Push-button igni- tion switch illumina- tion	ON (Tail lamps OFF)	9.5 V
					ON (Tail lamps ON)	<p style="text-align: center;">NOTE: The pulse width of this wave is varied by the illumination bright- ening/dimming level.</p>  <p style="text-align: right; font-size: small;">JPMIA0159GB</p>
134 (GR)	Ground	LOCK indicator lamp	Output	LOCK indicator lamp	OFF	Battery voltage
					ON	0 V
137 (O)	Ground	Receiver and sensor ground	Input	Ignition switch ON	0 V	
138 (Y)	Ground	Receiver and sensor power supply	Output	Ignition switch	OFF	0 V
					ACC or ON	5.0 V

A
B
C
D
E
F
G
H
I
J
K
DEF
M
N
O
P

DEF

BCM (BODY CONTROL MODULE)

< ECU DIAGNOSIS INFORMATION >

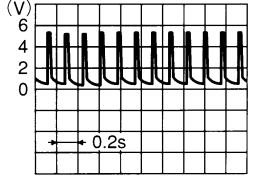
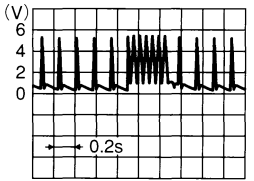
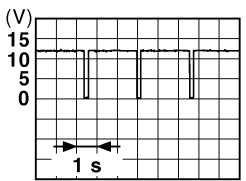
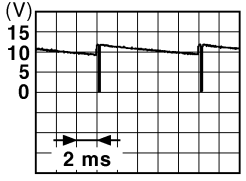
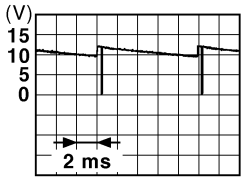
Terminal No. (Wire color)		Description		Condition	Value (Approx.)
+	-	Signal name	Input/ Output		
139 (L)	Ground	Tire pressure receiver communication	Input/ Output	Ignition switch ON	Standby state  OCC3881D
				When receiving the signal from the transmitter  OCC3880D	
140 (GR)	Ground	Selector lever P/N position	Input	Selector lever	P or N position Battery voltage
				Except P and N positions	0 V
141 (G)	Ground	Security indicator	Output	Security indicator	ON 0 V
				Blinking  JPMA0014GB 11.3 V	
				OFF Battery voltage	
142 (O)	Ground	Combination switch OUTPUT 5	Output	Combination switch (Wiper intermittent dial 4)	All switches OFF 0 V
				Turn signal switch RH  JPMA0031GB 10.7 V	
					Lighting switch 1ST
					Lighting switch HI
143 (P)	Ground	Combination switch OUTPUT 1	Output	Combination switch	All switches OFF (Wiper intermittent dial 4) 0 V
				Any of the conditions below with all switches OFF • Wiper intermittent dial 1 • Wiper intermittent dial 2 • Wiper intermittent dial 3 • Wiper intermittent dial 6 • Wiper intermittent dial 7  JPMA0032GB 10.7 V	
					Rear wiper switch INT (Wiper intermittent dial 4)
					Front wiper switch HI (Wiper intermittent dial 4)

BCM (BODY CONTROL MODULE)

< ECU DIAGNOSIS INFORMATION >

Terminal No. (Wire color)		Description		Condition	Value (Approx.)	
+	-	Signal name	Input/ Output			
144 (G)	Ground	Combination switch OUTPUT 2	Output	Combination switch	All switches OFF (Wiper intermittent dial 4)	0 V
					Front washer switch ON (Wiper intermittent dial 4)	
					Rear wiper switch ON (Wiper intermittent dial 4)	
					Rear washer switch ON (Wiper intermittent dial 4)	
					Any of the conditions below with all switches OFF <ul style="list-style-type: none"> • Wiper intermittent dial 1 • Wiper intermittent dial 5 • Wiper intermittent dial 6 	
145 (L)	Ground	Combination switch OUTPUT 3	Output	Combination switch (Wiper intermit- tent dial 4)	All switches OFF	0 V
					Front wiper switch INT	
					Front wiper switch LO	
					Lighting switch AUTO	
146 (SB)	Ground	Combination switch OUTPUT 4	Output	Combination switch (Wiper intermit- tent dial 4)	All switches OFF	0 V
					Front fog lamp switch ON	
					Lighting switch 2ND	
					Lighting switch PASS	
					Turn signal switch LH	
149 (W)	Ground	Tire pressure warn- ing check switch	Input	Ignition switch ON		11.8 V
						11.8 V
150 (LG)	Ground	Driver door switch	Input	Driver door switch	OFF (Door close)	11.8 V
					ON (Door open)	0 V
151 (G)	Ground	Rear window defog- ger relay control	Output	Rear window de- fogger	Active	0 V
					Not activated	Battery voltage

DEF

BCM (BODY CONTROL MODULE)

< ECU DIAGNOSIS INFORMATION >

Wiring Diagram - BCM -

INFOID:00000000557262

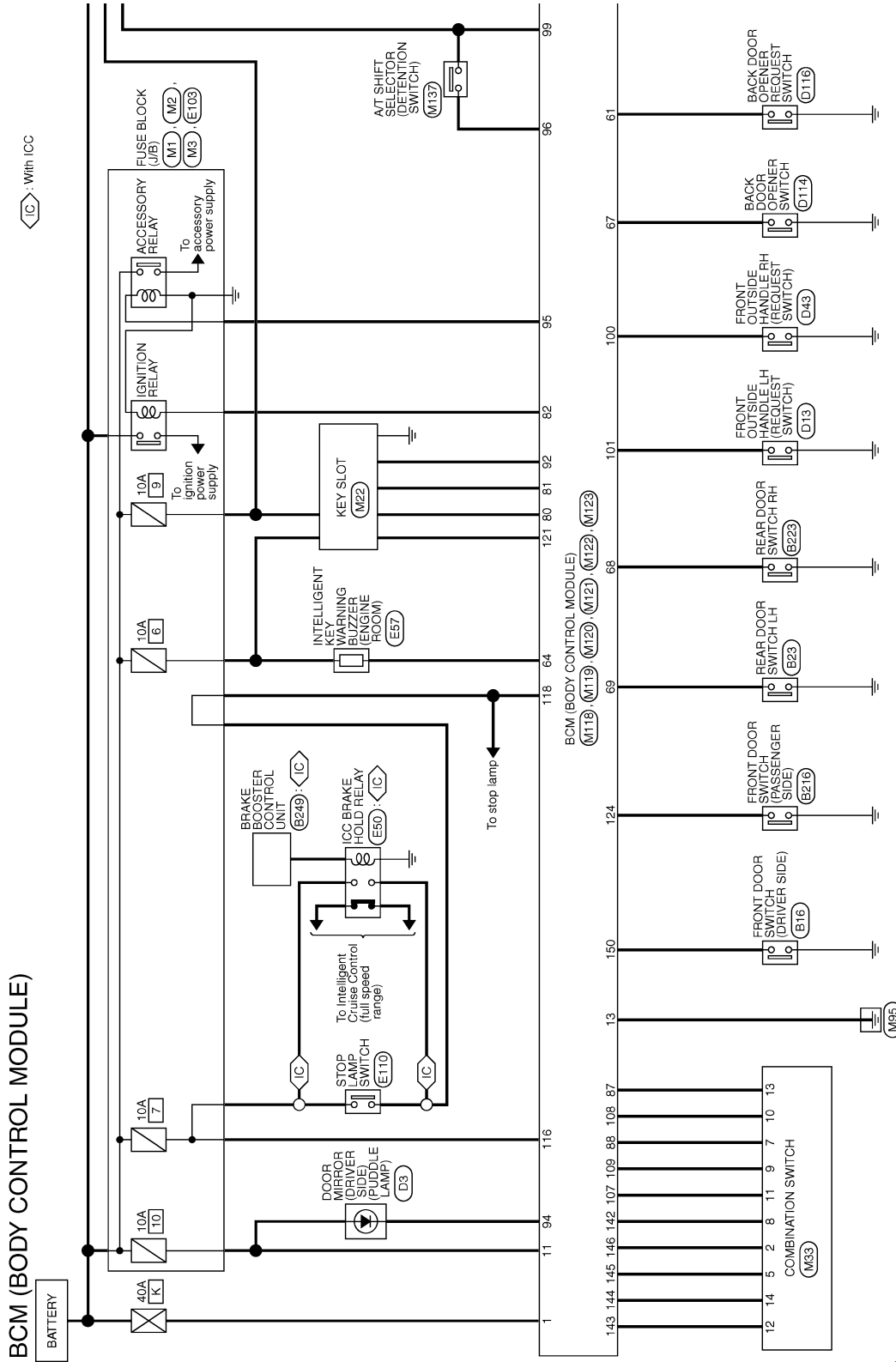

2009/07/16

JCMWA4820GB

BCM (BODY CONTROL MODULE)

< ECU DIAGNOSIS INFORMATION >

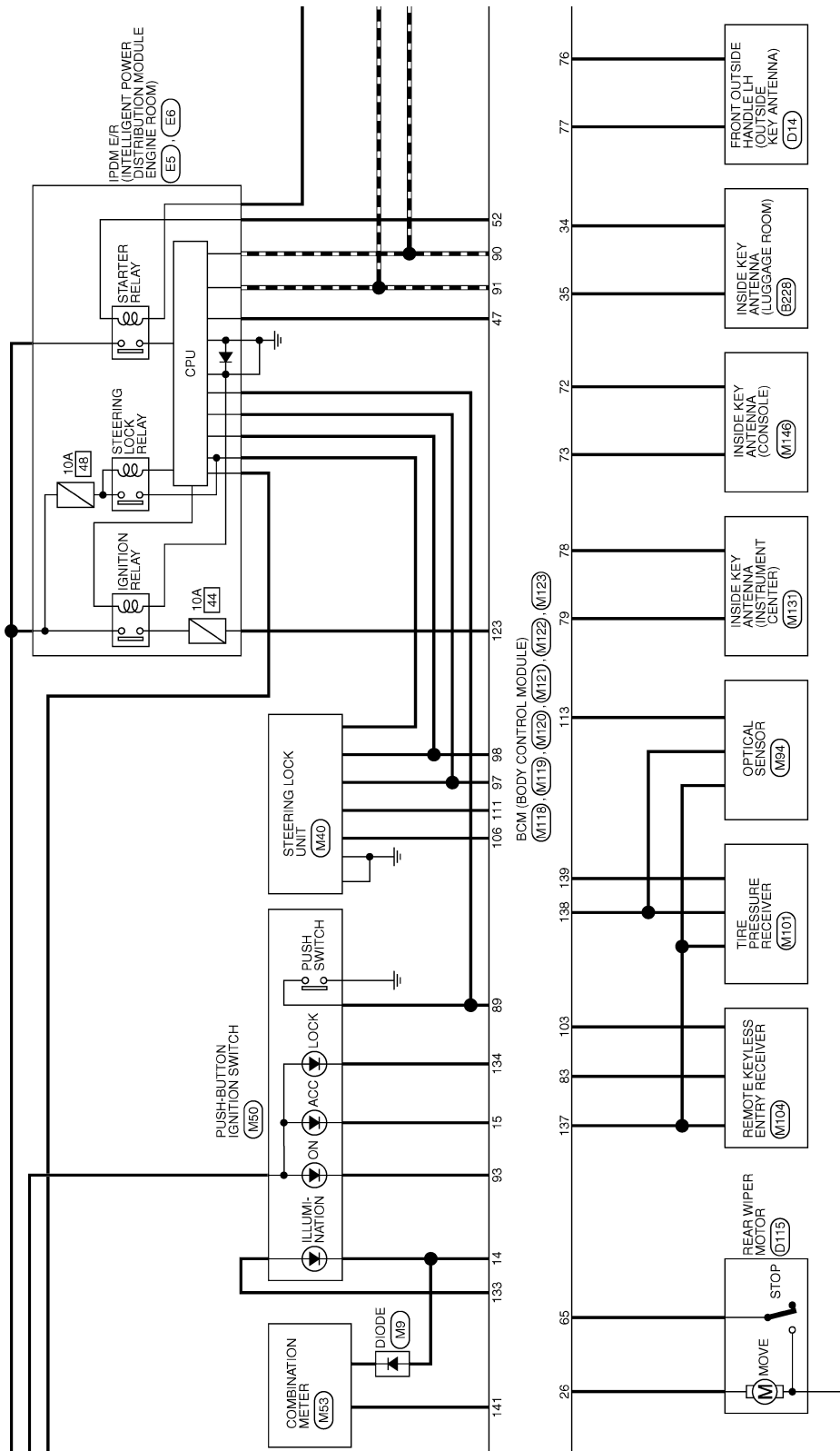

JCMWA4821GB

A
B
C
D
E
F
G
H
I
J
K
DEF
M
N
O
P

BCM (BODY CONTROL MODULE)

< ECU DIAGNOSIS INFORMATION >

- ◊ RF ◊ With sunroof
- ◊ PM ◊ With automatic drive positioner
- ◊ OP ◊ Without automatic drive positioner

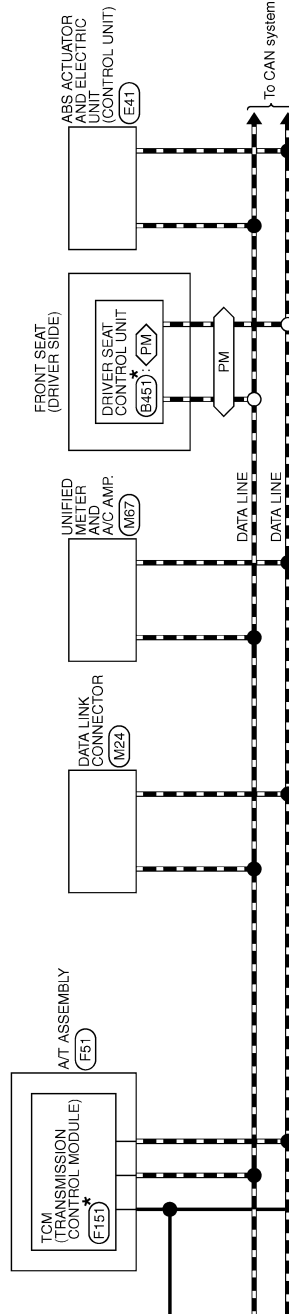

BCM (BODY CONTROL MODULE)
 (M11B) (M119) (M120) (M121) (M122) (M123)

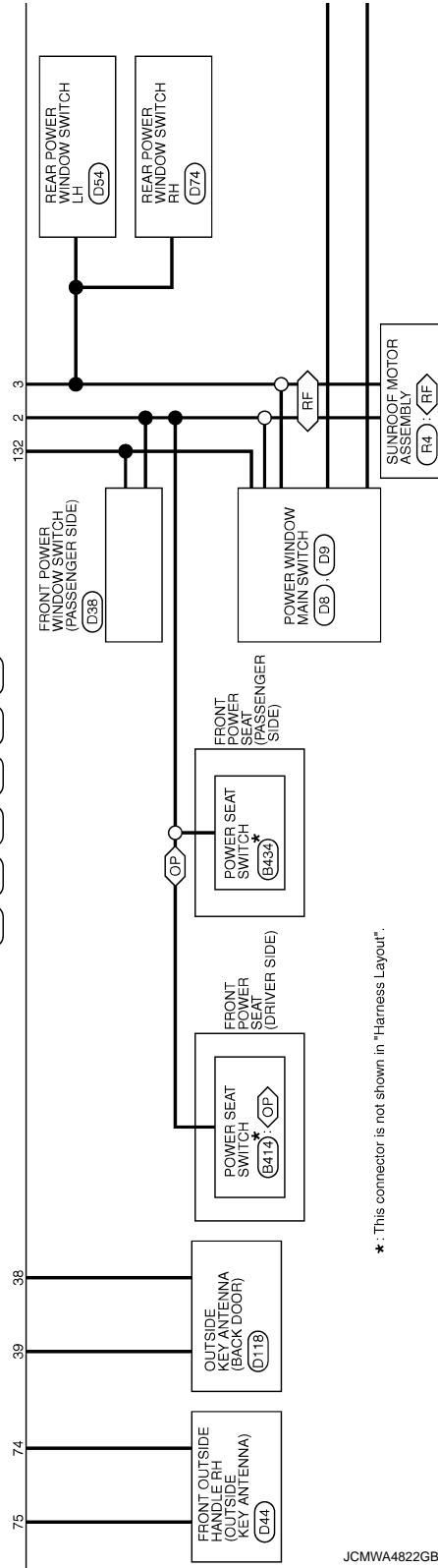

* : This connector is not shown in "Harness Layout".

JCMWA4822GB

BCM (BODY CONTROL MODULE)

< ECU DIAGNOSIS INFORMATION >

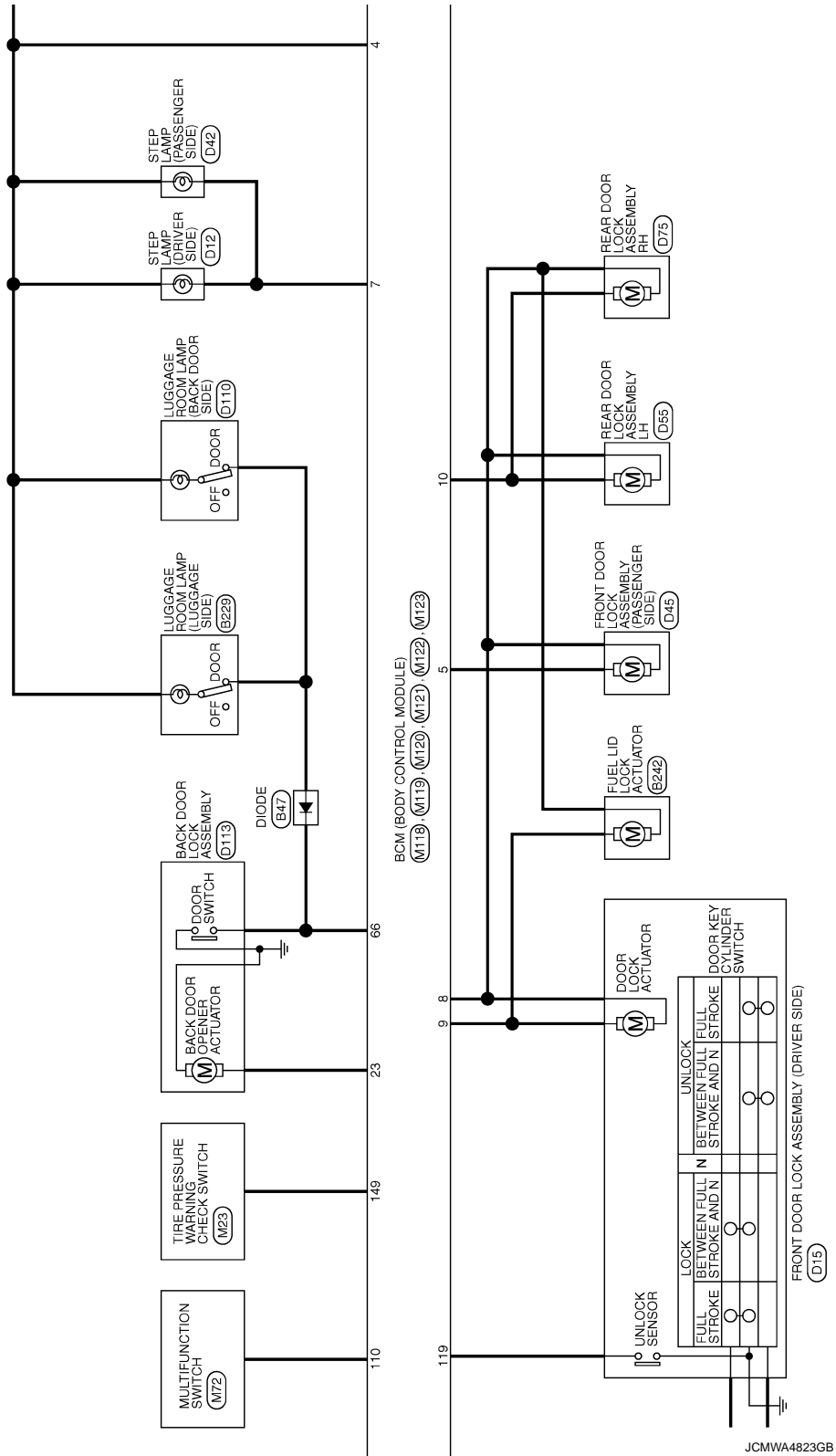

A
B
C
D
E
F
G
H
I
J
K
DEF
M
N
O
P

BCM (BODY CONTROL MODULE)

< ECU DIAGNOSIS INFORMATION >

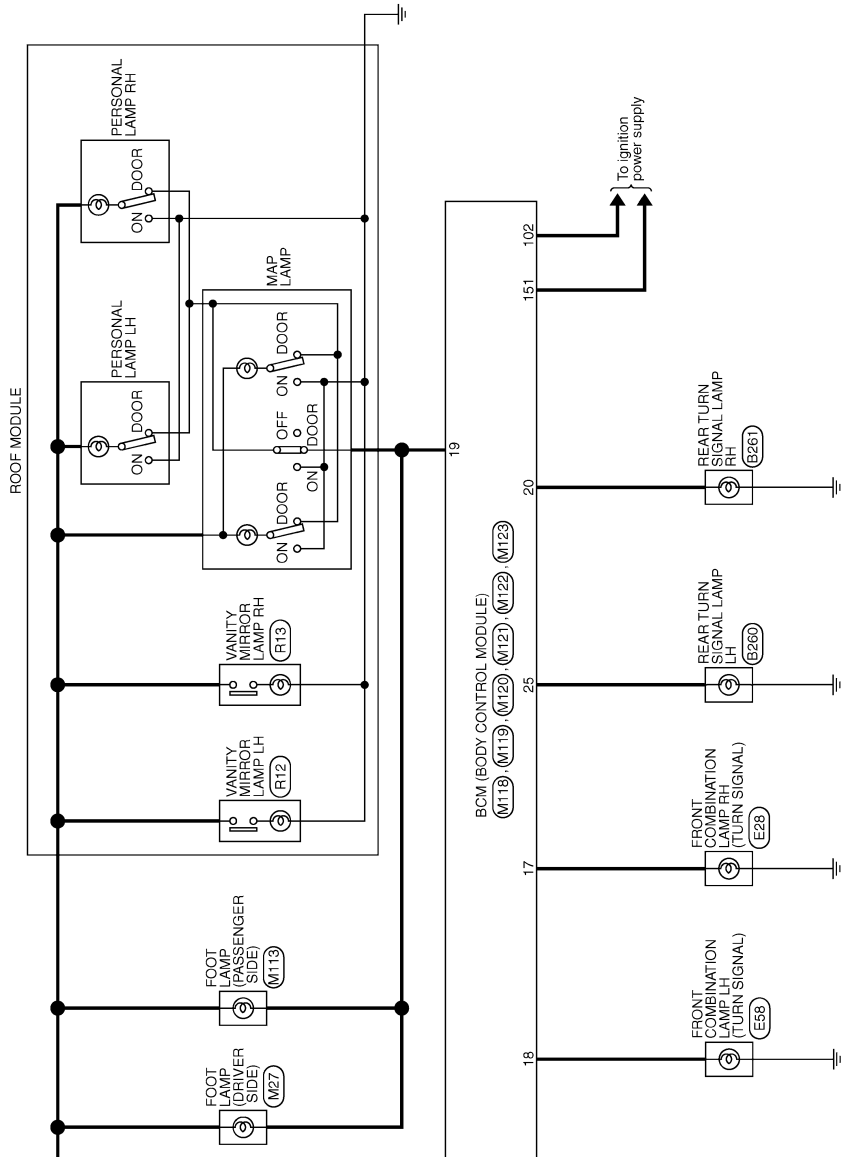

JCMWA4824GB

BCM (BODY CONTROL MODULE)

< ECU DIAGNOSIS INFORMATION >

BCM (BODY CONTROL MODULE)

Connector No.	M33
Connector Name	COMBINATION SWITCH
Connector Type	TH18FW-NH

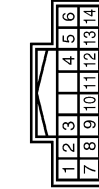

Terminal No.	Color of Wire	Signal Name [Specification]
1	P	FR WASHER(-)
2	SB	OUTPUT 4
3	GR	FR WASHER(+)
4	G	IGN
5	L	OUTPUT 3
6	B	GND
7	V	INPUT 3
8	O	OUTPUT 5
9	Y	INPUT 2
10	R	INPUT 4
11	LG	INPUT 1
12	P	OUTPUT 1
13	BR	INPUT 5
14	G	OUTPUT 2

Connector No.	M18
Connector Name	BCM (BODY CONTROL MODULE)
Connector Type	M08PF-LC



Terminal No.	Color of Wire	Signal Name [Specification]
1	W	BAT (F/L)
2	W	POWER WINDOW POWER SUPPLY (BAT)
3	Y	POWER WINDOW POWER SUPPLY (BAP)

Connector No.	M119
Connector Name	BCM (BODY CONTROL MODULE)
Connector Type	NS18FW-CS

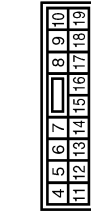

Terminal No.	Color of Wire	Signal Name [Specification]
4	LG	INTERIOR ROOM LAMP POWER SUPPLY
5	L	PASSENGER DOOR UNLOCK OUTPUT
6	V	STEP LAMP OUTPUT
7	Y	ALL DOOR FUEL LID LOCK OUTPUT
8	G	DRIVER DOOR FUEL LID UNLOCK OUTPUT
9	G	REAR DOOR UNLOCK OUTPUT
10	BR	BAT (FUSE)
11	R	GND
12	B	PUSH-BUTTON IGNITION SW ILL GND
13	O	ACC IND
14	W	ACC IND
15	Y	TURN SIGNAL RH (FRONT)
16	W	TURN SIGNAL LH (FRONT)
17	W	TURN SIGNAL LH (FRONT)
18	O	ROOM LAMP TIMER CONTROL
19	V	ROOM LAMP TIMER CONTROL

Connector No.	M120
Connector Name	BCM (BODY CONTROL MODULE)
Connector Type	NS12FW-CS

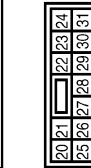

Terminal No.	Color of Wire	Signal Name [Specification]
20	V	TURN SIGNAL RH (REAR)
21	G	BACK DOOR OPEN OUTPUT
22	G	TURN SIGNAL LH (REAR)
23	G	REAR WIPER OUTPUT
24	G	
25	G	
26	G	

Connector No.	M121
Connector Name	BCM (BODY CONTROL MODULE)
Connector Type	TH40FGY-NH

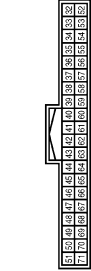

Terminal No.	Color of Wire	Signal Name [Specification]
34	SB	LUGGAGE ROOM ANT-
35	V	LUGGAGE ROOM ANT+
36	B	BACK DOOR ANT-
37	W	BACK DOOR ANT+
38	W	IGN RELAY (PDM E/R) CONT
39	W	STARTER RELAY CONT
40	Y	BACK DOOR OPERNER REQUEST SW
41	Y	L-KEY WARN BUZZER (ENG ROOM)
42	SB	REAR WIPER STOP POSITION
43	W	BACK DOOR SW
44	W	BACK DOOR SW
45	W	BACK DOOR OPERNER SW
46	W	REAR RH DOOR SW
47	W	REAR LH DOOR SW
48	W	
49	W	
50	W	
51	W	
52	W	
53	W	
54	W	
55	W	
56	W	
57	W	
58	W	
59	W	

Connector No.	M122
Connector Name	BCM (BODY CONTROL MODULE)
Connector Type	TH40FB-NH

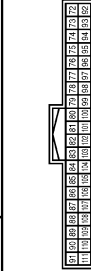

Terminal No.	Color of Wire	Signal Name [Specification]
72	R	ROOM ANTIZ-
73	G	ROOM ANTIZ+
74	SB	PASSENGER DOOR ANT-
75	GR	PASSENGER DOOR ANT+
76	V	DRIVER DOOR ANT-
77	LG	DRIVER DOOR ANT+
78	Y	ROOM ANTI-
79	BR	ROOM ANTI+
80	GR	NATS ANT LAMP

81	W	NATS ANT AMP
82	R	IGN RELAY (F/B) CONT
83	Y	KEYLESS ENTRY RECEIVER COMM
87	BR	COMBI SW INPUT 5
88	V	COMBI SW INPUT 3
89	BR	PUSH SW
90	P	CAN-L
91	L	CAN-H
92	LG	KEY SLOT ILL
93	V	ON IND
94	Y	PUDDLE LAMP CONT
95	O	ACC RELAY CONT
96	GR	A/T SHIF SELECTOR POWER SUPPLY
97	L	S/L CONDITION 1
98	P	S/L CONDITION 2
99	R	SHIF P
100	G	PASSENGER DOOR REQUEST SW
101	SB	DRIVER DOOR REQUEST SW
102	O	BLOWER FAN MOTOR RELAY CONT
103	LG	KEYLESS ENTRY RECEIVER POWER SUPPLY
106	W	S/L UNIT POWER SUPPLY
107	LG	COMBI SW INPUT 1
108	R	COMBI SW INPUT 2
109	Y	COMBI SW INPUT 4
110	G	HAZARD SW
111	Y	S/L UNIT COMM

A B C D E F G H I J K M N O P

DEF

JCMWA4825GB

BCM (BODY CONTROL MODULE)

< ECU DIAGNOSIS INFORMATION >

BCM (BODY CONTROL MODULE)

Connector No.	M123
Connector Name	BCM (BODY CONTROL MODULE)
Connector Type	TH40FG-14H



Terminal No.	Color of Wire	Signal Name (Specification)
113	P	OPTICAL SENSOR
116	SB	STOP LAMP SW 1
118	P	STOP LAMP SW 2
119	SB	DR DOOR UNLOCK SENSOR
121	BR	KEY SLOT SW
123	W	IGN F/B
124	LG	PASSENGER DOOR SW
132	BR	POWER WINDOW SW COMM
133	W	PUSH-BUTTON IGNITION SW ILL POWER
134	GR	LOCK IND
137	O	RECEIVER/SENSOR GND
138	Y	RECEIVER/SENSOR POWER SUPPLY
139	L	TIRE PRESSURE RECEIVER COMM
140	GR	SHIFT N/P
141	G	SECURITY INDICATOR OUTPUT
142	O	COMBI SW OUTPUT 5
143	P	COMBI SW OUTPUT 1
144	G	COMBI SW OUTPUT 2
145	L	COMBI SW OUTPUT 3
146	SB	COMBI SW OUTPUT 4
149	W	TIRE PRESS WARNING CHECK SW
150	LG	DRIVER DOOR SW
151	G	REAR WINDOW DEFOGGER RELAY CONT

JCMWA4826GB

Fail-safe

INFOID:00000000557263

FAIL-SAFE CONTROL BY DTC

BCM performs fail-safe control when any DTC are detected.

BCM (BODY CONTROL MODULE)

< ECU DIAGNOSIS INFORMATION >

Display contents of CONSULT	Fail-safe	Cancellation
B2013: ID DISCORD BCM-S/L	Inhibit engine cranking	Erase DTC
B2014: CHAIN OF S/L-BCM	Inhibit engine cranking	Erase DTC
B2190: NATS ANTENNA AMP	Inhibit engine cranking	Erase DTC
B2191: DIFFERENCE OF KEY	Inhibit engine cranking	Erase DTC
B2192: ID DISCORD BCM-ECM	Inhibit engine cranking	Erase DTC
B2193: CHAIN OF BCM-ECM	Inhibit engine cranking	Erase DTC
B2195: ANTI SCANNING	Inhibit engine cranking	Ignition switch ON → OFF
B2557: VEHICLE SPEED	Inhibit steering lock	When normal vehicle speed signals are received from ABS actuator and electric unit (control unit) for 500 ms
B2560: STARTER CONT RELAY	Inhibit engine cranking	500 ms after the following CAN signal communication status becomes consistent <ul style="list-style-type: none"> • Starter control relay signal • Starter relay status signal
B2601: SHIFT POSITION	Inhibit steering lock	500 ms after the following signal reception status becomes consistent <ul style="list-style-type: none"> • Selector lever P position switch signal • P range signal (CAN)
B2602: SHIFT POSITION	Inhibit steering lock	5 seconds after the following BCM recognition conditions are fulfilled <ul style="list-style-type: none"> • Ignition switch is in the ON position • Selector lever P position switch signal: Except P position (battery voltage) • Vehicle speed: 4 km/h (2.5 MPH) or more
B2603: SHIFT POSI STATUS	Inhibit steering lock	500 ms after the following BCM recognition conditions are fulfilled <ul style="list-style-type: none"> • Ignition switch is in the ON position • Selector lever P position switch signal: Except P position (battery voltage) • Selector lever P/N position signal: Except P and N positions (0 V)
B2604: PNP SW	Inhibit steering lock	500 ms after any of the following BCM recognition conditions are fulfilled <ul style="list-style-type: none"> • Status 1 <ul style="list-style-type: none"> - Ignition switch is in the ON position - Selector lever P/N position signal: P and N position (battery voltage) - P range signal or N range signal (CAN): ON • Status 2 <ul style="list-style-type: none"> - Ignition switch is in the ON position - Selector lever P/N position signal: Except P and N positions (0 V) - P range signal and N range signal (CAN): OFF
B2605: PNP SW	Inhibit steering lock	500 ms after any of the following BCM recognition conditions are fulfilled <ul style="list-style-type: none"> • Ignition switch is in the ON position <ul style="list-style-type: none"> - Power position: IGN - Selector lever P/N position signal: Except P and N positions (0 V) - Interlock/PNP switch signal (CAN): OFF • Status 2 <ul style="list-style-type: none"> - Ignition switch is in the ON position - Selector lever P/N position signal: P or N position (battery voltage) - PNP switch signal (CAN): ON
B2606: S/L RELAY	Inhibit engine cranking	500 ms after the following CAN signal communication status becomes consistent <ul style="list-style-type: none"> • Steering lock relay signal (Request signal) • Steering lock relay signal (Condition signal)

A
B
C
D
E
F
G
H
I
J
K
DEF
M
N
O
P

BCM (BODY CONTROL MODULE)

< ECU DIAGNOSIS INFORMATION >

Display contents of CONSULT	Fail-safe	Cancellation
B2607: S/L RELAY	Inhibit engine cranking	500 ms after the following CAN signal communication status becomes consistent <ul style="list-style-type: none"> Steering lock relay signal (Request signal) Steering lock relay signal (Condition signal)
B2608: STARTER RELAY	Inhibit engine cranking	500 ms after the following signal communication status becomes consistent <ul style="list-style-type: none"> Starter motor relay control signal Starter relay status signal (CAN)
B2609: S/L STATUS	<ul style="list-style-type: none"> Inhibit engine cranking Inhibit steering lock 	When the following steering lock conditions agree <ul style="list-style-type: none"> BCM steering lock control status Steering lock condition No. 1 signal status Steering lock condition No. 2 signal status
B260A: IGNITION RELAY	Inhibit engine cranking	500 ms after the following conditions are fulfilled <ul style="list-style-type: none"> IGN relay (IPDM E/R) control signal: OFF (Battery voltage) Ignition ON signal (CAN to IPDM E/R): OFF (Request signal) Ignition ON signal (CAN from IPDM E/R): OFF (Condition signal)
B260F: ENG STATE SIG LOST	Maintains the power supply position attained at the time of DTC detection	When any of the following conditions are fulfilled <ul style="list-style-type: none"> Power position changes to ACC Receives engine status signal (CAN)
B2612: S/L STATUS	<ul style="list-style-type: none"> Inhibit engine cranking Inhibit steering lock 	When any of the following conditions are fulfilled <ul style="list-style-type: none"> Steering lock unit status signal (CAN) is received normally The BCM steering lock control status matches the steering lock status recognized by the steering lock unit status signal (CAN from IPDM E/R)
B2617: STARTER RELAY CIRC	Inhibit engine cranking	1 second after the starter motor relay control inside BCM becomes normal
B2618: BCM	Inhibit engine cranking	1 second after the ignition relay (IPDM E/R) control inside BCM becomes normal
B2619: BCM	Inhibit engine cranking	1 second after the steering lock unit power supply output control inside BCM becomes normal
B261E: VEHICLE TYPE	Inhibit engine cranking	BCM initialization
B26E9: S/L STATUS	<ul style="list-style-type: none"> Inhibit engine cranking Inhibit steering lock 	When BCM transmits the LOCK request signal to steering lock unit, and receives LOCK response signal from steering lock unit, the following conditions are fulfilled <ul style="list-style-type: none"> Steering condition No. 1 signal: LOCK (0 V) Steering condition No. 2 signal: LOCK (Battery voltage)

HIGH FLASHER OPERATION

BCM detects the turn signal lamp circuit status by the current value.

BCM increases the turn signal lamp blinking speed if the bulb or harness open is detected with the turn signal lamp operating.

NOTE:

The blinking speed is normal while activating the hazard warning lamp.

REAR WIPER MOTOR PROTECTION

BCM detects the rear wiper stopping position according to the rear wiper stop position signal.

When the rear wiper stop position signal does not change for more than 5 seconds while driving the rear wiper, BCM stops power supply to protect the rear wiper motor.

Condition of cancellation

1. More than 1 minute is passed after the rear wiper stops.
2. Turn rear wiper switch OFF.
3. Operate the rear wiper switch or rear washer switch.

DTC Inspection Priority Chart

INFOID:000000005577264

If some DTCs are displayed at the same time, perform inspections one by one based on the following priority chart.

BCM (BODY CONTROL MODULE)

< ECU DIAGNOSIS INFORMATION >

Priority	DTC	A
1	B2562: LOW VOLTAGE	A
2	<ul style="list-style-type: none"> • U1000: CAN COMM CIRCUIT • U1010: CONTROL UNIT (CAN) 	B
3	<ul style="list-style-type: none"> • B2190: NATS ANTENNA AMP • B2191: DIFFERENCE OF KEY • B2192: ID DISCORD BCM-ECM • B2193: CHAIN OF BCM-ECM • B2195: ANTI SCANNING 	C
4	<ul style="list-style-type: none"> • B2013: ID DISCORD BCM-S/L • B2014: CHAIN OF S/L-BCM • B2553: IGNITION RELAY • B2555: STOP LAMP • B2556: PUSH-BTN IGN SW • B2557: VEHICLE SPEED • B2560: STARTER CONT RELAY • B2601: SHIFT POSITION • B2602: SHIFT POSITION • B2603: SHIFT POSI STATUS • B2604: PNP SW • B2605: PNP SW • B2606: S/L RELAY • B2607: S/L RELAY • B2608: STARTER RELAY • B2609: S/L STATUS • B260A: IGNITION RELAY • B260B: STEERING LOCK UNIT • B260C: STEERING LOCK UNIT • B260D: STEERING LOCK UNIT • B260F: ENG STATE SIG LOST • B2612: S/L STATUS • B2614: ACC RELAY CIRC • B2615: BLOWER RELAY CIRC • B2616: IGN RELAY CIRC • B2617: STARTER RELAY CIRC • B2618: BCM • B2619: BCM • B261A: PUSH-BTN IGN SW • B261E: VEHICLE TYPE • B26E9: S/L STATUS • B26EA: KEY REGISTRATION • C1729: VHCL SPEED SIG ERR • U0415: VEHICLE SPEED SIG 	D E F G H I J K
5	<ul style="list-style-type: none"> • C1704: LOW PRESSURE FL • C1705: LOW PRESSURE FR • C1706: LOW PRESSURE RR • C1707: LOW PRESSURE RL • C1708: [NO DATA] FL • C1709: [NO DATA] FR • C1710: [NO DATA] RR • C1711: [NO DATA] RL • C1716: [PRESSDATA ERR] FL • C1717: [PRESSDATA ERR] FR • C1718: [PRESSDATA ERR] RR • C1719: [PRESSDATA ERR] RL • C1734: CONTROL UNIT 	M N O P
6	<ul style="list-style-type: none"> • B2621: INSIDE ANTENNA • B2622: INSIDE ANTENNA • B2623: INSIDE ANTENNA 	DEF

DTC Index

INFOID:00000000577265

NOTE:

BCM (BODY CONTROL MODULE)

< ECU DIAGNOSIS INFORMATION >

The details of time display are as follows.

- CRNT: A malfunction is detected now.
- PAST: A malfunction was detected in the past.

IGN counter is displayed on Freeze Frame Data. For details of Freeze Frame Data, refer to [BCS-16. "COMMON ITEM : CONSULT-III Function \(BCM - COMMON ITEM\)"](#).

CONSULT display	Fail-safe	Freeze Frame Data •Vehicle Speed •Odo/Trip Meter •Vehicle Condition	Intelligent Key warning lamp ON	Tire pressure monitor warning lamp ON	Reference page
No DTC is detected. further testing may be required.	—	—	—	—	—
U1000: CAN COMM CIRCUIT	—	—	—	—	BCS-37
U1010: CONTROL UNIT (CAN)	—	—	—	—	BCS-38
U0415: VEHICLE SPEED SIG	—	—	—	—	BCS-39
B2013: ID DISCORD BCM-S/L	×	×	—	—	SEC-48
B2014: CHAIN OF S/L-BCM	×	×	—	—	SEC-49
B2190: NATS ANTENNA AMP	×	—	—	—	SEC-41
B2191: DIFFERENCE OF KEY	×	—	—	—	SEC-44
B2192: ID DISCORD BCM-ECM	×	—	—	—	SEC-45
B2193: CHAIN OF BCM-ECM	×	—	—	—	SEC-46
B2195: ANTI SCANNING	×	—	—	—	SEC-47
B2553: IGNITION RELAY	—	×	—	—	PCS-49
B2555: STOP LAMP	—	×	—	—	SEC-52
B2556: PUSH-BTN IGN SW	—	×	×	—	SEC-54
B2557: VEHICLE SPEED	×	×	×	—	SEC-56
B2560: STARTER CONT RELAY	×	×	×	—	SEC-57
B2562: LOW VOLTAGE	—	×	—	—	BCS-40
B2601: SHIFT POSITION	×	×	×	—	SEC-58
B2602: SHIFT POSITION	×	×	×	—	SEC-61
B2603: SHIFT POSI STATUS	×	×	×	—	SEC-63
B2604: PNP SW	×	×	×	—	SEC-66
B2605: PNP SW	×	×	×	—	SEC-68
B2606: S/L RELAY	×	×	×	—	SEC-70
B2607: S/L RELAY	×	×	×	—	SEC-71
B2608: STARTER RELAY	×	×	×	—	SEC-73
B2609: S/L STATUS	×	×	×	—	SEC-75
B260A: IGNITION RELAY	×	×	×	—	PCS-51
B260B: STEERING LOCK UNIT	—	×	×	—	SEC-79
B260C: STEERING LOCK UNIT	—	×	×	—	SEC-80
B260D: STEERING LOCK UNIT	—	×	×	—	SEC-81
B260F: ENG STATE SIG LOST	×	×	×	—	SEC-82
B2612: S/L STATUS	×	×	×	—	SEC-86
B2614: ACC RELAY CIRC	—	×	×	—	PCS-53
B2615: BLOWER RELAY CIRC	—	×	×	—	PCS-56
B2616: IGN RELAY CIRC	—	×	×	—	PCS-59

BCM (BODY CONTROL MODULE)

< ECU DIAGNOSIS INFORMATION >

CONSULT display	Fail-safe	Freeze Frame Data •Vehicle Speed •Odo/Trip Meter •Vehicle Condition	Intelligent Key warning lamp ON	Tire pressure monitor warning lamp ON	Reference page	
B2617: STARTER RELAY CIRC	×	×	×	—	SEC-90	A
B2618: BCM	×	×	×	—	PCS-62	B
B2619: BCM	×	×	×	—	SEC-92	C
B261A: PUSH-BTN IGN SW	—	×	×	—	SEC-93	
B261E: VEHICLE TYPE	×	×	× (Turn ON for 15 seconds)	—	SEC-96	D
B2621: INSIDE ANTENNA	—	×	—	—	DLK-59	
B2622: INSIDE ANTENNA	—	×	—	—	DLK-61	E
B2623: INSIDE ANTENNA	—	×	—	—	DLK-63	
B26E1: ENG STATE NO RES	×	×	×	—	SEC-83	F
B26E9: S/L STATUS	×	×	× (Turn ON for 15 seconds)	—	SEC-84	
B26EA: KEY REGISTRATION	—	×	× (Turn ON for 15 seconds)	—	SEC-85	G
C1704: LOW PRESSURE FL	—	—	—	×	WT-25	
C1705: LOW PRESSURE FR	—	—	—	×		H
C1706: LOW PRESSURE RR	—	—	—	×		
C1707: LOW PRESSURE RL	—	—	—	×		
C1708: [NO DATA] FL	—	—	—	×	WT-27	I
C1709: [NO DATA] FR	—	—	—	×		
C1710: [NO DATA] RR	—	—	—	×		J
C1711: [NO DATA] RL	—	—	—	×		
C1716: [PRESSDATA ERR] FL	—	—	—	×	WT-30	
C1717: [PRESSDATA ERR] FR	—	—	—	×		K
C1718: [PRESSDATA ERR] RR	—	—	—	×		
C1719: [PRESSDATA ERR] RL	—	—	—	×		
C1729: VHCL SPEED SIG ERR	—	—	—	×	WT-32	DEF
C1734: CONTROL UNIT	—	—	—	×	WT-34	

REAR WINDOW DEFOGGER DOES NOT OPERATE

< SYMPTOM DIAGNOSIS >

SYMPTOM DIAGNOSIS

REAR WINDOW DEFOGGER DOES NOT OPERATE

Diagnosis Procedure

INFOID:000000005172703

1. CHECK POWER SUPPLY AND GROUND CIRCUIT

Check power supply and ground circuit.
Refer to [DEF-9, "Diagnosis Procedure"](#).

Is the inspection result normal?

- YES >> GO TO 2.
- NO >> Repair or replace the malfunctioning parts.

2. CHECK REAR WINDOW DEFOGGER SWITCH

Check rear window defogger switch.
Refer to [DEF-10, "Component Function Check"](#).

Is the inspection result normal?

- YES >> GO TO 3.
- NO >> Repair or replace the malfunctioning parts.

3. CHECK REAR WINDOW DEFOGGER RELAY

Check rear window defogger relay.
Refer to [DEF-11, "Component Function Check"](#).

Is the inspection result normal?

- YES >> GO TO 4.
- NO >> Repair or replace the malfunctioning parts.

4. CHECK REAR WINDOW DEFOGGER

Check rear window defogger.
Refer to [DEF-13, "Component Function Check"](#).

Is the inspection result normal?

- YES >> GO TO 5.
- NO >> Repair or replace the malfunctioning parts.

5. CONFIRM THE OPERATION

Confirm the operation again.

Is the inspection result normal?

- YES >> Check intermittent incident. Refer to [GI-37, "Intermittent Incident"](#).
- NO >> GO TO 1.

REAR WINDOW DEFOGGER AND DOOR MIRROR DEFOGGER DO NOT OPERATE.

< SYMPTOM DIAGNOSIS >

REAR WINDOW DEFOGGER AND DOOR MIRROR DEFOGGER DO NOT OPERATE.

Diagnosis Procedure

INFOID:000000005172704

1. CHECK POWER SUPPLY AND GROUND CIRCUIT

Check power supply and ground circuit.
Refer to [DEF-9, "Diagnosis Procedure"](#).

Is the inspection result normal?

YES >> GO TO 2.

NO >> Repair or replace the malfunctioning parts.

2. CHECK REAR WINDOW DEFOGGER SWITCH

Check rear window defogger switch.
Refer to [DEF-10, "Component Function Check"](#).

Is the inspection result normal?

YES >> GO TO 3.

NO >> Repair or replace the malfunctioning parts.

3. CHECK REAR WINDOW DEFOGGER RELAY

Check rear window defogger relay.
Refer to [DEF-11, "Component Function Check"](#).

Is the inspection result normal?

YES >> GO TO 4.

NO >> Repair or replace the malfunctioning parts.

4. CONFIRM THE OPERATION

Confirm the operation again.

Is the inspection result normal?

YES >> Check intermittent incident. Refer to [GI-37, "Intermittent Incident"](#).

NO >> GO TO 1.

A
B
C
D
E
F
G
H
I
J
K
M
N
O
P

DEF

REAR WINDOW DEFOGGER DOES NOT OPERATE BUT BOTH DOOR MIRROR DEFOGGER OPERATE.

< SYMPTOM DIAGNOSIS >

REAR WINDOW DEFOGGER DOES NOT OPERATE BUT BOTH DOOR MIRROR DEFOGGER OPERATE.

Diagnosis Procedure

INFOID:000000005172705

1. CHECK REAR WINDOW DEFOGGER

Check rear window defogger.

Refer to [DEF-13, "Component Function Check"](#).

Is the inspection result normal?

YES >> GO TO 2.

NO >> Repair or replace the malfunctioning parts.

2. CONFIRM THE OPERATION

Confirm the operation again

Is the inspection result normal?

YES >> Check intermittent incident. Refer to [GI-37, "Intermittent Incident"](#).

NO >> GO TO 1.

DOOR MIRROR DEFOGGER DOES NOT OPERATE

< SYMPTOM DIAGNOSIS >

DOOR MIRROR DEFOGGER DOES NOT OPERATE BOTH SIDES

BOTH SIDES : Diagnosis Procedure

INFOID:000000005172706

1.CHECK DOOR MIRROR DEFOGGER

Check door mirror defogger.

Refer to [DEF-16, "Component Function Check"](#).

Is the inspection result normal?

YES >> GO TO 2.

NO >> Repair or replace the malfunctioning parts.

2.CONFIRM THE OPERATION

Confirm the operation again.

Is the inspection result normal?

YES >> Check intermittent incident. Refer to [GI-37, "Intermittent Incident"](#).

NO >> GO TO 1.

DRIVER SIDE

DRIVER SIDE : Diagnosis Procedure

INFOID:000000005172707

1.CHECK DRIVER SIDE DOOR MIRROR DEFOGGER

Check driver side door mirror defogger.

Refer to [DEF-17, "Component Function Check"](#).

Is the inspection result normal?

YES >> GO TO 2.

NO >> Repair or replace the malfunctioning parts.

2.CONFIRM THE OPERATION

Confirm the operation again.

Is the inspection result normal?

YES >> Check intermittent incident. Refer to [GI-37, "Intermittent Incident"](#).

NO >> GO TO 1.

PASSENGER SIDE

PASSENGER SIDE : Diagnosis Procedure

INFOID:000000005172708

1.CHECK PASSENGER SIDE DOOR MIRROR DEFOGGER.

Check passenger side door mirror defogger.

Refer to [DEF-19, "Component Function Check"](#).

Is the inspection result normal?

YES >> GO TO 2.

NO >> Repair or replace the malfunctioning parts.

2.CONFIRM THE OPERATION

Confirm the operation again.

Is the inspection result normal?

YES >> Check intermittent incident. Refer to [GI-37, "Intermittent Incident"](#).

NO >> GO TO 1.

A
B
C
D
E
F
G
H
I
J
K
M
N
O
P

DEF

ON IS NOT DISPLAYED WHEN PRESSING REAR WINDOW DEFOGGER SWITCH BUT IT IS OPERATED

< SYMPTOM DIAGNOSIS >

ON IS NOT DISPLAYED WHEN PRESSING REAR WINDOW DEFOGGER SWITCH BUT IT IS OPERATED

Diagnosis Procedure

INFOID:000000005172709

1. CHECK AV CONTROL UNIT FUNCTION

Check that the AV control unit is operating normally.

- Base audio without navigation system. Refer to [AV-71, "Work Flow"](#).
- Bose audio without navigation system. Refer to [AV-234, "Work Flow \(Multi AV\)"](#).
- Bose audio with navigation system. Refer to [AV-429, "Work Flow \(Multi AV\)"](#).

Is the inspection result normal?

YES >> GO TO 2.

NO >> Repair or replace the malfunctioning parts.

2. CONFIRM THE OPERATION

Confirm the operation again.

Is the inspection result normal?

YES >> Check intermittent incident. Refer to [GI-37, "Intermittent Incident"](#).

NO >> GO TO 1.

REAR WINDOW DEFOGGER INDICATOR DOES NOT ILLUMINATE

< SYMPTOM DIAGNOSIS >

REAR WINDOW DEFOGGER INDICATOR DOES NOT ILLUMINATE

Diagnosis Procedure

INFOID:000000005172710

1. CHECK MULTIFUNCTION SWITCH (REAR WINDOW DEFOGGER SWITCH)

Check rear window defogger operate.

Is the inspection result normal?

- YES >> Replace multifunction switch (rear window defogger switch). Refer to [AV-138, "Removal and Installation"](#) (Base audio without navigation system), [AV-333, "Removal and Installation"](#) (Bose audio without navigation system) or [AV-536, "Removal and Installation"](#) (Bose audio with navigation system).
- NO >> Check rear window defogger system. Refer to [DEF-3, "Work Flow"](#)

A
B
C
D
E
F
G
H
I
J
K
DEF
M
N
O
P

DEF

PRECAUTIONS

< PRECAUTION >

PRECAUTION

PRECAUTIONS

Precaution for Supplemental Restraint System (SRS) "AIR BAG" and "SEAT BELT PRE-TENSIONER"

INFOID:000000005172711

The Supplemental Restraint System such as "AIR BAG" and "SEAT BELT PRE-TENSIONER", used along with a front seat belt, helps to reduce the risk or severity of injury to the driver and front passenger for certain types of collision. This system includes seat belt switch inputs and dual stage front air bag modules. The SRS system uses the seat belt switches to determine the front air bag deployment, and may only deploy one front air bag, depending on the severity of a collision and whether the front occupants are belted or unbelted. Information necessary to service the system safely is included in the "SRS AIR BAG" and "SEAT BELT" of this Service Manual.

WARNING:

- To avoid rendering the SRS inoperative, which could increase the risk of personal injury or death in the event of a collision which would result in air bag inflation, all maintenance must be performed by an authorized NISSAN/INFINITI dealer.
- Improper maintenance, including incorrect removal and installation of the SRS, can lead to personal injury caused by unintentional activation of the system. For removal of Spiral Cable and Air Bag Module, see the "SRS AIR BAG".
- Do not use electrical test equipment on any circuit related to the SRS unless instructed to in this Service Manual. SRS wiring harnesses can be identified by yellow and/or orange harnesses or harness connectors.

PRECAUTIONS WHEN USING POWER TOOLS (AIR OR ELECTRIC) AND HAMMERS

WARNING:

- When working near the Air Bag Diagnosis Sensor Unit or other Air Bag System sensors with the ignition ON or engine running, DO NOT use air or electric power tools or strike near the sensor(s) with a hammer. Heavy vibration could activate the sensor(s) and deploy the air bag(s), possibly causing serious injury.
- When using air or electric power tools or hammers, always switch the ignition OFF, disconnect the battery, and wait at least 3 minutes before performing any service.

FILAMENT

< REMOVAL AND INSTALLATION >

REMOVAL AND INSTALLATION

FILAMENT

Inspection and Repair

INFOID:000000005172712

INSPECTION

1. When measuring voltage, wrap tin foil around the top of the negative probe. Then press the foil against the wire with your finger.

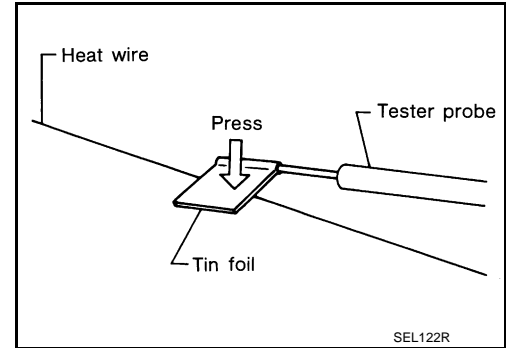

2. Attach probe circuit tester (in Volt range) to middle portion of each filament.

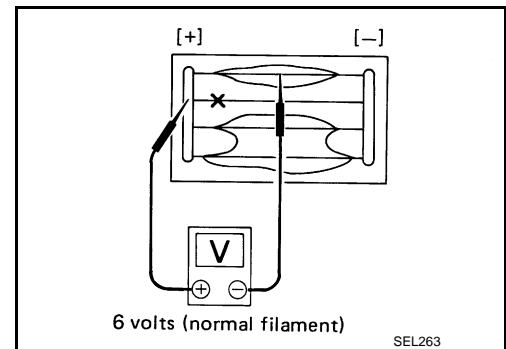

3. If a filament is burned out, circuit tester registers 0 or battery voltage.
4. To locate burned out point, move probe to left and right along filament. Test needle will swing abruptly when probe passes the point.

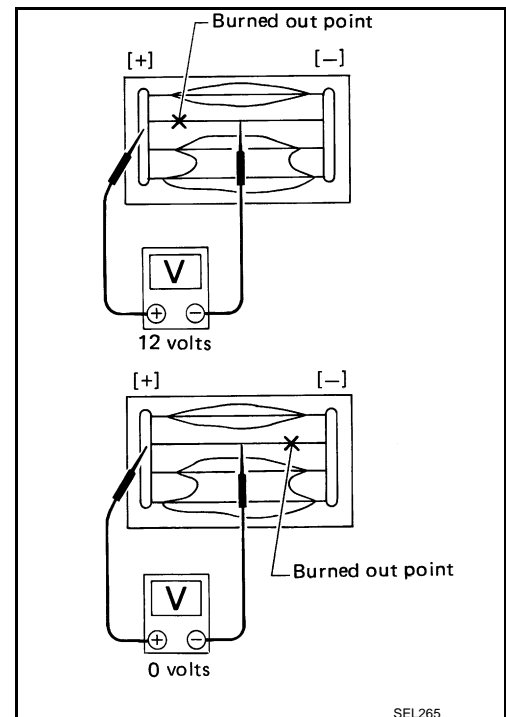

REPAIR

REPAIR EQUIPMENT

- Conductive silver composition (Dupont No. 4817 or equivalent)

A
B
C
D
E
F
G
H
I
J
K
DEF
M
N
O
P

FILAMENT

< REMOVAL AND INSTALLATION >

- Ruler 30 cm (11.8 in) long
- Drawing pen
- Heat gun
- Alcohol
- Cloth

REPAIRING PROCEDURE

1. Wipe broken heat wire and its surrounding area clean with a cloth dampened in alcohol.
2. Apply a small amount of conductive silver composition to tip of drawing pen. Shake silver composition container before use.
3. Place ruler on glass along broken line. Deposit conductive silver composition on break with drawing pen. Slightly overlap existing heat wire on both sides [preferably 5 mm (0.20 in)] of the break.

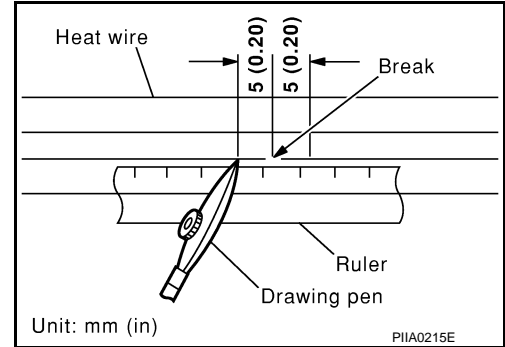

4. After repair has been completed, check repaired wire for continuity. This check should be conducted 10 minutes after silver composition is deposited. Do not touch repaired area while test is being conducted.

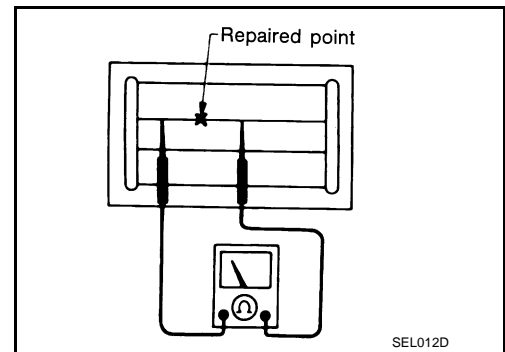

5. Apply a constant stream of hot air directly to the repaired area for approximately 20 minutes with a heat gun. A minimum distance of 3 cm (1.2 in) should be kept between repaired area and hot air outlet. If a heat gun is not available, let the repaired area dry for 24 hours.

