

SECTION **FAX**
FRONT AXLE

A
B
C

FAX

CONTENTS

E

2WD	NVH Troubleshooting Chart10	F
SYMPTOM DIAGNOSIS 3	PRECAUTION11	
NOISE, VIBRATION AND HARSHNESS (NVH) TROUBLESHOOTING 3	PRECAUTIONS11	G
NVH Troubleshooting Chart3	Caution for Supplemental Restraint System (SRS) "AIR BAG" and "SEAT BELT PRE-TENSIONER"11	H
PRECAUTION 4	Caution Necessary for Steering Wheel Rotation after Battery Disconnect11	I
PRECAUTIONS 4	Precautions for Drive Shaft12	
Caution Necessary for Steering Wheel Rotation after Battery Disconnect4	PREPARATION13	
PREPARATION 5	PREPARATION13	J
PREPARATION 5	Special Service Tool13	
Commercial Service Tool5	Commercial Service Tools13	
PERIODIC MAINTENANCE 6	PERIODIC MAINTENANCE15	K
FRONT WHEEL HUB AND KNUCKLE 6	FRONT WHEEL HUB AND KNUCKLE15	L
Inspection6	Inspection15	
REMOVAL AND INSTALLATION 7	FRONT DRIVE SHAFT16	
FRONT WHEEL HUB AND KNUCKLE 7	Inspection16	M
Exploded View7	REMOVAL AND INSTALLATION17	
Removal and Installation7	FRONT WHEEL HUB AND KNUCKLE17	N
Inspection8	Exploded View17	
SERVICE DATA AND SPECIFICATIONS (SDS) 9	Removal and Installation17	
SERVICE DATA AND SPECIFICATIONS (SDS) 9	Inspection18	O
Wheel Bearing9	FRONT DRIVE SHAFT BOOT19	
AWD	Exploded View19	P
SYMPTOM DIAGNOSIS10	WHEEL SIDE20	
NOISE, VIBRATION AND HARSHNESS (NVH) TROUBLESHOOTING10	WHEEL SIDE : Removal and Installation20	
	FINAL DRIVE SIDE23	
	FINAL DRIVE SIDE : Removal and Installation23	
	Inspection23	

FRONT DRIVE SHAFT	24	FINAL DRIVE SIDE	28
Exploded View	24	FINAL DRIVE SIDE : Disassembly and Assembly...	28
LEFT SIDE	25	Inspection	31
LEFT SIDE : Removal and Installation	25	SERVICE DATA AND SPECIFICATIONS	
RIGHT SIDE	25	(SDS)	32
RIGHT SIDE : Removal and Installation	25	SERVICE DATA AND SPECIFICATIONS	
WHEEL SIDE	26	(SDS)	32
WHEEL SIDE : Disassembly and Assembly	26	Wheel Bearing	32
		Drive Shaft	32

NOISE, VIBRATION AND HARSHNESS (NVH) TROUBLESHOOTING

< SYMPTOM DIAGNOSIS >

[2WD]

SYMPTOM DIAGNOSIS

NOISE, VIBRATION AND HARSHNESS (NVH) TROUBLESHOOTING

NVH Troubleshooting Chart

INFOID:000000004343089

Use chart below to find the cause of the symptom. If necessary, repair or replace these parts.

Reference page		FAX-7	—	FAX-6	NVH in FAX and FSU sections	NVH in WT section	NVH in WT section	NVH in BR section	NVH in ST section	
Possible cause and SUSPECTED PARTS		Improper installation, looseness	Parts interference	Wheel bearing damage	FRONT AXLE AND FRONT SUSPENSION	TIRE	ROAD WHEEL	BRAKE	STEERING	
Symptom	FRONT AXLE	Noise	x	x	x	x	x	x	x	
		Shake	x	x	x	x	x	x	x	
		Vibration	x	x	x	x	x			x
		Shimmy	x	x		x	x	x	x	x
		Judder	x			x	x	x	x	x
		Poor quality ride or handling	x	x		x	x	x		

x: Applicable

A
B
C
E
F
G
H
I
J
K
L
M
N
O
P

FAX

PRECAUTION

PRECAUTIONS

Precaution Necessary for Steering Wheel Rotation after Battery Disconnect

INFOID:000000004894527

NOTE:

- Before removing and installing any control units, first turn the push-button ignition switch to the LOCK position, then disconnect both battery cables.
- After finishing work, confirm that all control unit connectors are connected properly, then re-connect both battery cables.
- Always use CONSULT-III to perform self-diagnosis as a part of each function inspection after finishing work. If a DTC is detected, perform trouble diagnosis according to self-diagnosis results.

For vehicle with steering lock unit, if the battery is disconnected or discharged, the steering wheel will lock and cannot be turned.

If turning the steering wheel is required with the battery disconnected or discharged, follow the operation procedure below before starting the repair operation.

OPERATION PROCEDURE

1. Connect both battery cables.

NOTE:

Supply power using jumper cables if battery is discharged.

2. Turn the push-button ignition switch to ACC position.
(At this time, the steering lock will be released.)
3. Disconnect both battery cables. The steering lock will remain released with both battery cables disconnected and the steering wheel can be turned.
4. Perform the necessary repair operation.
5. When the repair work is completed, re-connect both battery cables. With the brake pedal released, turn the push-button ignition switch from ACC position to ON position, then to LOCK position. (The steering wheel will lock when the push-button ignition switch is turned to LOCK position.)
6. Perform self-diagnosis check of all control units using CONSULT-III.

PREPARATION

< PREPARATION >

[2WD]

PREPARATION

PREPARATION

Commercial Service Tool

INFOID:000000004894523

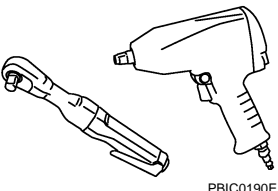
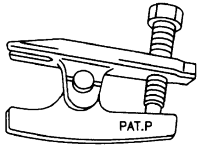
Tool name	Description
<p>Power tool</p>  <p>PBIC0190E</p>	<p>Loosening bolts and nuts</p>
<p>Ball joint remover</p>  <p>PAT.P</p> <p>NT146</p>	<p>Removing ball joint for steering knuckle</p>

A

B

C

FAX

E

F

G

H

I

J

K

L

M

N

O

P

PERIODIC MAINTENANCE

FRONT WHEEL HUB AND KNUCKLE

Inspection

INFOID:000000004343091

MOUNTING INSPECTION

Make sure that the mounting conditions (looseness, backlash) of each component and component conditions (wear, damage) are normal.

WHEEL BEARING INSPECTION

- Move wheel hub and bearing assembly in the axial direction by hand. Make sure there is no looseness of wheel bearing.

Standard

Axial end play : Refer to [FAX-9, "Wheel Bearing"](#).

- Rotate wheel hub and bearing assembly and make sure that is no unusual noise or other irregular conditions. If there is any of irregular conditions, replace wheel hub and bearing assembly.

FRONT WHEEL HUB AND KNUCKLE

< REMOVAL AND INSTALLATION >

[2WD]

REMOVAL AND INSTALLATION

FRONT WHEEL HUB AND KNUCKLE

Exploded View

INFOID:000000004343092

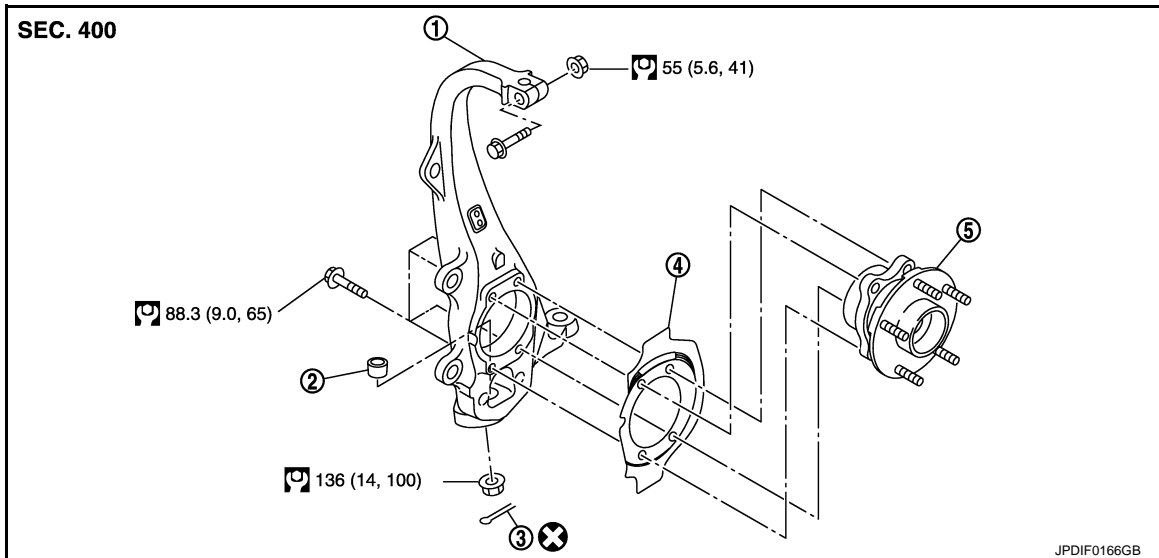

- | | | |
|---------------------|-----------------------------------|---------------|
| 1. Steering knuckle | 2. Ball seat | 3. Cotter pin |
| 4. Splash guard | 5. Wheel hub and bearing assembly | |

Refer to [GI-4, "Components"](#) for symbols in the figure.

Removal and Installation

INFOID:000000004343093

REMOVAL

1. Remove tires with power tool.
2. Remove wheel sensor and sensor harness. Refer to [BRC-108, "FRONT WHEEL SENSOR : Exploded View"](#).
CAUTION:
Never pull on wheel sensor harness.
3. Remove brake hose bracket. Refer to [BR-20, "FRONT : Exploded View"](#).
4. Remove caliper assembly. Hang caliper assembly in a place where it will not interfere with work. Refer to [BR-34, "BRAKE CALIPER ASSEMBLY : Exploded View"](#).
CAUTION:
Never depress brake pedal while brake caliper is removed.
5. Remove disc rotor. Refer to [BR-35, "BRAKE CALIPER ASSEMBLY : Removal and Installation"](#).
6. Remove wheel hub and bearing assembly, and then remove splash guard.
7. Remove steering outer socket. Refer to [ST-24, "2WD : Exploded View"](#).
8. Remove cotter pin of transverse link and steering knuckle, and then loosen nut.
9. Separate steering knuckle from upper link.
10. Separate steering knuckle from transverse link so as not to damage ball joint boot using the ball joint remover (commercial service tool), and remove steering knuckle.
CAUTION:
Temporarily tighten the nut to prevent damage to threads and to prevent the ball joint remover from suddenly coming off.

INSTALLATION

Note the following, and install in the reverse order of the removal.

- Perform the final tightening of each of parts under unladen conditions, which were removed when removing wheel hub and bearing assembly and steering knuckle.

FRONT WHEEL HUB AND KNUCKLE

< REMOVAL AND INSTALLATION >

[2WD]

- Never reuse cotter pin.

Inspection

INFOID:000000004343094

INSPECTION AFTER REMOVAL

Check components for deformation, cracks, and other damage. Replace it if necessary.

Ball Joint Inspection

Check boots of transverse link and steering outer socket ball joint for breakage, axial play, and torque. Refer to [FSU-13. "Inspection"](#) and [ST-32. "2WD : Inspection"](#).

INSPECTION AFTER INSTALLATION

1. Check wheel sensor harness for proper connection. Refer to [BRC-108. "FRONT WHEEL SENSOR : Exploded View"](#).
2. Check the wheel alignment. Refer to [FSU-8. "Inspection"](#).
3. Adjust neutral position of steering angle sensor. Refer to [BRC-9. "ADJUSTMENT OF STEERING ANGLE SENSOR NEUTRAL POSITION : Special Repair Requirement"](#).

SERVICE DATA AND SPECIFICATIONS (SDS)

< SERVICE DATA AND SPECIFICATIONS (SDS)

[2WD]

SERVICE DATA AND SPECIFICATIONS (SDS)

SERVICE DATA AND SPECIFICATIONS (SDS)

Wheel Bearing

INFOID:000000004343095

Item	Standard
Axial end play	0.05 mm (0.002 in) or less

A

B

C

FAX

E

F

G

H

I

J

K

L

M

N

O

P

NOISE, VIBRATION AND HARSHNESS (NVH) TROUBLESHOOTING

< SYMPTOM DIAGNOSIS >

[AWD]

SYMPTOM DIAGNOSIS

NOISE, VIBRATION AND HARSHNESS (NVH) TROUBLESHOOTING

NVH Troubleshooting Chart

INFOID:000000004343096

Use chart below to find the cause of the symptom. If necessary, repair or replace these parts.

Reference page															
		—	FAX-31	—	FAX-17	—	FAX-15	NVH in FAX and FSU sections	Refer to Front axle in this chart.	NVH in WT section	NVH in WT section	Refer to DRIVE SHAFT in this chart.	NVH in BR section	NVH in ST section	
Possible cause and SUSPECTED PARTS															
		Excessive joint angle	Joint sliding resistance	Imbalance	Improper installation, looseness	Parts interference	Wheel bearing damage	FRONT AXLE AND FRONT SUSPENSION	FRONT AXLE	TIRE	ROAD WHEEL	DRIVE SHAFT	BRAKE	STEERING	
Symptom	DRIVE SHAFT	Noise	x	x			x	x	x	x	x		x	x	
		Shake	x		x		x	x	x	x	x		x	x	
	FRONT AXLE	Noise				x	x	x	x		x	x	x	x	x
		Shake				x	x	x	x		x	x	x	x	x
		Vibration				x	x	x	x		x		x		x
		Shimmy				x	x		x		x	x		x	x
		Judder				x			x		x	x		x	x
		Poor quality ride or handling				x	x		x		x	x			

x: Applicable

PRECAUTION

PRECAUTIONS

Precaution for Supplemental Restraint System (SRS) "AIR BAG" and "SEAT BELT PRE-TENSIONER"

INFOID:000000004894525

The Supplemental Restraint System such as "AIR BAG" and "SEAT BELT PRE-TENSIONER", used along with a front seat belt, helps to reduce the risk or severity of injury to the driver and front passenger for certain types of collision. This system includes seat belt switch inputs and dual stage front air bag modules. The SRS system uses the seat belt switches to determine the front air bag deployment, and may only deploy one front air bag, depending on the severity of a collision and whether the front occupants are belted or unbelted. Information necessary to service the system safely is included in the "SRS AIR BAG" and "SEAT BELT" of this Service Manual.

WARNING:

- To avoid rendering the SRS inoperative, which could increase the risk of personal injury or death in the event of a collision that would result in air bag inflation, all maintenance must be performed by an authorized NISSAN/INFINITI dealer.
- Improper maintenance, including incorrect removal and installation of the SRS, can lead to personal injury caused by unintentional activation of the system. For removal of Spiral Cable and Air Bag Module, see the "SRS AIR BAG".
- Do not use electrical test equipment on any circuit related to the SRS unless instructed to in this Service Manual. SRS wiring harnesses can be identified by yellow and/or orange harnesses or harness connectors.

PRECAUTIONS WHEN USING POWER TOOLS (AIR OR ELECTRIC) AND HAMMERS

WARNING:

- When working near the Air Bag Diagnosis Sensor Unit or other Air Bag System sensors with the ignition ON or engine running, DO NOT use air or electric power tools or strike near the sensor(s) with a hammer. Heavy vibration could activate the sensor(s) and deploy the air bag(s), possibly causing serious injury.
- When using air or electric power tools or hammers, always switch the ignition OFF, disconnect the battery, and wait at least 3 minutes before performing any service.

Precaution Necessary for Steering Wheel Rotation after Battery Disconnect

INFOID:000000004894526

NOTE:

- Before removing and installing any control units, first turn the push-button ignition switch to the LOCK position, then disconnect both battery cables.
- After finishing work, confirm that all control unit connectors are connected properly, then re-connect both battery cables.
- Always use CONSULT-III to perform self-diagnosis as a part of each function inspection after finishing work. If a DTC is detected, perform trouble diagnosis according to self-diagnosis results.

For vehicle with steering lock unit, if the battery is disconnected or discharged, the steering wheel will lock and cannot be turned.

If turning the steering wheel is required with the battery disconnected or discharged, follow the operation procedure below before starting the repair operation.

OPERATION PROCEDURE

1. Connect both battery cables.
 - NOTE:**
Supply power using jumper cables if battery is discharged.
2. Turn the push-button ignition switch to ACC position.
(At this time, the steering lock will be released.)
3. Disconnect both battery cables. The steering lock will remain released with both battery cables disconnected and the steering wheel can be turned.
4. Perform the necessary repair operation.

A
B
C
E
F
G
H
I
J
K
L
M
N
O
P

FAX

PRECAUTIONS

[AWD]

< PRECAUTION >

5. When the repair work is completed, re-connect both battery cables. With the brake pedal released, turn the push-button ignition switch from ACC position to ON position, then to LOCK position. (The steering wheel will lock when the push-button ignition switch is turned to LOCK position.)
6. Perform self-diagnosis check of all control units using CONSULT-III.

Precautions for Drive Shaft

INFOID:000000004343099

- Observe the following precautions when disassembling and assembling drive shaft.
 - Never disassemble joint sub-assembly because it is non-overhaul parts.
 - Perform work in a location which is as dust-free as possible.
 - Clean the parts, before disassembling and assembling.
 - Prevent the entry of foreign objects during disassembly of the service location.
 - Reassemble disassembled parts carefully in the correct order. If work is interrupted, a clean cover must be placed over parts.
 - Use paper waste. Fabric shop cloths must not be used because of the danger of lint adhering to parts.
 - Clean disassembled parts (except for rubber parts) with kerosene which shall be removed by blowing with air or wiping with paper waste.

PREPARATION

< PREPARATION >

[AWD]

PREPARATION

PREPARATION

Special Service Tool

INFOID:000000004343100

The actual shapes of Kent-Moore tools may differ from those of special service tools illustrated here.

Tool number (Kent-Moore No.) Tool name	Description
KV40107300 (-) Boot band crimping tool	Installing boot band
KV40107500 (-) Drive shaft attachment	Removing drive shaft
KV38107900 (-) Protector a: 32 mm (1.26 in) dia.	Installing drive shaft

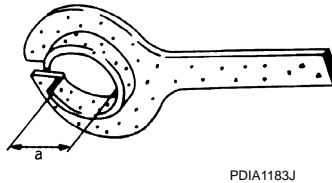
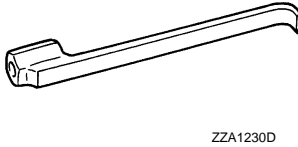
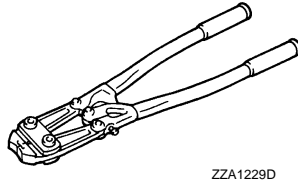

Commercial Service Tools

INFOID:000000004894524

Tool name	Description
Power tool	Loosening bolts and nuts
Ball joint remover	Removing ball joint for steering knuckle

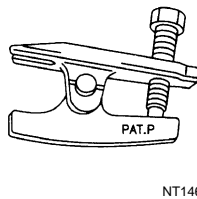
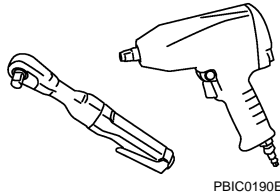

PREPARATION

< PREPARATION >

[AWD]

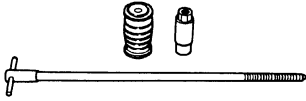
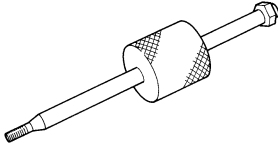
Tool name	Description
<p data-bbox="191 197 362 222">Drive shaft puller</p>  <p data-bbox="826 415 914 432">JPDIG0152ZZ</p>	<p data-bbox="1000 197 1386 222">Remove drive shaft joint sub assembly</p>
<p data-bbox="191 449 350 474">Sliding hammer</p>  <p data-bbox="826 665 894 682">ZZA0023D</p>	<p data-bbox="1000 449 1195 474">Remove drive shaft</p>

FRONT WHEEL HUB AND KNUCKLE

< PERIODIC MAINTENANCE >

[AWD]

PERIODIC MAINTENANCE

FRONT WHEEL HUB AND KNUCKLE

Inspection

INFOID:000000004343102

MOUNTING INSPECTION

Make sure that the mounting conditions (looseness, backlash) of each component and component conditions (wear, damage) are normal.

WHEEL BEARING INSPECTION

- Move wheel hub and bearing assembly in the axial direction by hand. Make sure there is no looseness of wheel bearing.

Standard

Axial end play : Refer to [FAX-32, "Wheel Bearing"](#).

- Rotate wheel hub and bearing assembly and make sure that is no unusual noise or other irregular conditions. If there is any of irregular conditions, replace wheel hub and bearing assembly.

A
B
C
FAX
E
F
G
H
I
J
K
L
M
N
O
P

FRONT DRIVE SHAFT

< PERIODIC MAINTENANCE >

[AWD]

FRONT DRIVE SHAFT

Inspection

INFOID:000000004343103

- Check drive shaft mounting point and joint for looseness and other damage.
- Check boot for cracks and other damage.

CAUTION:

Replace entire drive shaft assembly when noise or vibration occurs from drive shaft.

FRONT WHEEL HUB AND KNUCKLE

< REMOVAL AND INSTALLATION >

[AWD]

REMOVAL AND INSTALLATION

FRONT WHEEL HUB AND KNUCKLE

Exploded View

INFOID:000000004343104

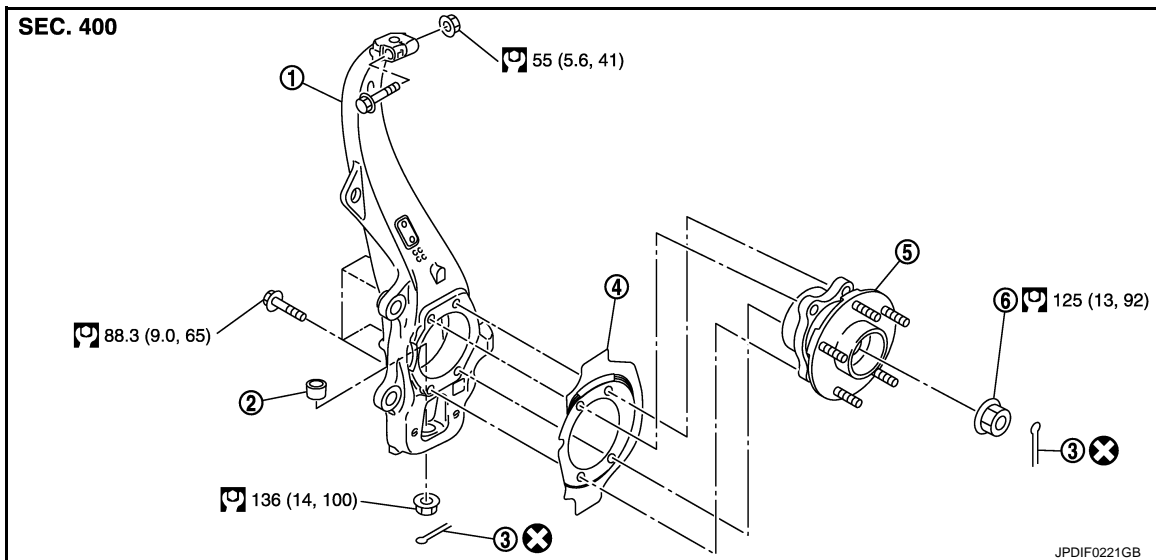

- | | | |
|---------------------|-----------------------------------|-----------------------|
| 1. Steering knuckle | 2. Ball seat | 3. Cotter pin |
| 4. Splash guard | 5. Wheel hub and bearing assembly | 6. Wheel hub lock nut |

Refer to [GI-4, "Components"](#) for symbols in the figure.

Removal and Installation

INFOID:000000004343105

REMOVAL

1. Remove tires with power tool.
2. Remove wheel sensor and sensor harness. Refer to [BRC-108, "FRONT WHEEL SENSOR : Exploded View"](#).
CAUTION:
Never pull on wheel sensor harness.
3. Remove brake hose bracket. Refer to [BR-20, "FRONT : Exploded View"](#).
4. Remove caliper assembly. Hang caliper assembly in a place where it will not interfere with work. Refer to [BR-34, "BRAKE CALIPER ASSEMBLY : Exploded View"](#).
CAUTION:
Never depress brake pedal while brake caliper is removed.
5. Remove disc rotor. Refer to [BR-35, "BRAKE CALIPER ASSEMBLY : Removal and Installation"](#).
6. Remove cotter pin, and then loosen wheel hub lock nut with power tool.
7. Patch wheel hub lock nut with a piece of wood. Hammer the wood to disengage wheel hub and bearing assembly from drive shaft.
CAUTION:
 - **Never place drive shaft joint at an extreme angle. Also be careful not to overextend slide joint.**
 - **Never allow drive shaft to hang down without support for or joint sub-assembly, shaft and the other parts.****NOTE:**
Use suitable puller, if wheel hub and bearing assembly and drive shaft cannot be separated even after performing the above procedure.
8. Remove wheel hub lock nut.

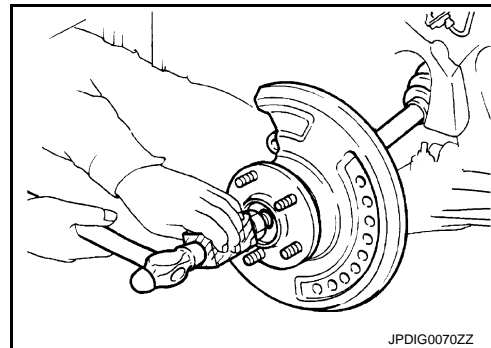

FRONT WHEEL HUB AND KNUCKLE

[AWD]

< REMOVAL AND INSTALLATION >

9. Remove wheel hub and bearing assembly, and then remove splash guard.
10. Remove steering outer socket. Refer to [ST-33, "AWD : Exploded View"](#).
11. Remove cotter pin of transverse link and steering knuckle, and then loosen nut.
12. Separate steering knuckle from upper link.
13. Separate steering knuckle link from transverse so as not to damage ball joint boot using the ball joint remover (commercial service tool), and remove steering knuckle.

CAUTION:

Temporarily tighten the nut to prevent damage to threads and to prevent the ball joint remover from suddenly coming off.

INSTALLATION

Note the following, and install in the reverse order of the removal.

- Perform the final tightening of each of parts under unladen conditions, which were removed when removing wheel hub and bearing assembly and steering knuckle.
- Never reuse cotter pin.

Inspection

INFOID:000000004343106

INSPECTION AFTER REMOVAL

Check components for deformation, cracks, and other damage. Replace it if necessary.

Ball Joint Inspection

Check boots of transverse link and steering outer socket ball joint for breakage, axial play, and torque. Refer to [FSU-32, "Inspection"](#) and [ST-42, "AWD : Inspection"](#).

INSPECTION AFTER INSTALLATION

1. Check wheel sensor harness for proper connection. Refer to [BRC-108, "FRONT WHEEL SENSOR : Exploded View"](#).
2. Check the wheel alignment. Refer to [FSU-8, "Inspection"](#).
3. Adjust neutral position of steering angle sensor. Refer to [BRC-9, "ADJUSTMENT OF STEERING ANGLE SENSOR NEUTRAL POSITION : Special Repair Requirement"](#).

FRONT DRIVE SHAFT BOOT

< REMOVAL AND INSTALLATION >

[AWD]

FRONT DRIVE SHAFT BOOT

Exploded View

INFOID:000000004343107

LEFT SIDE

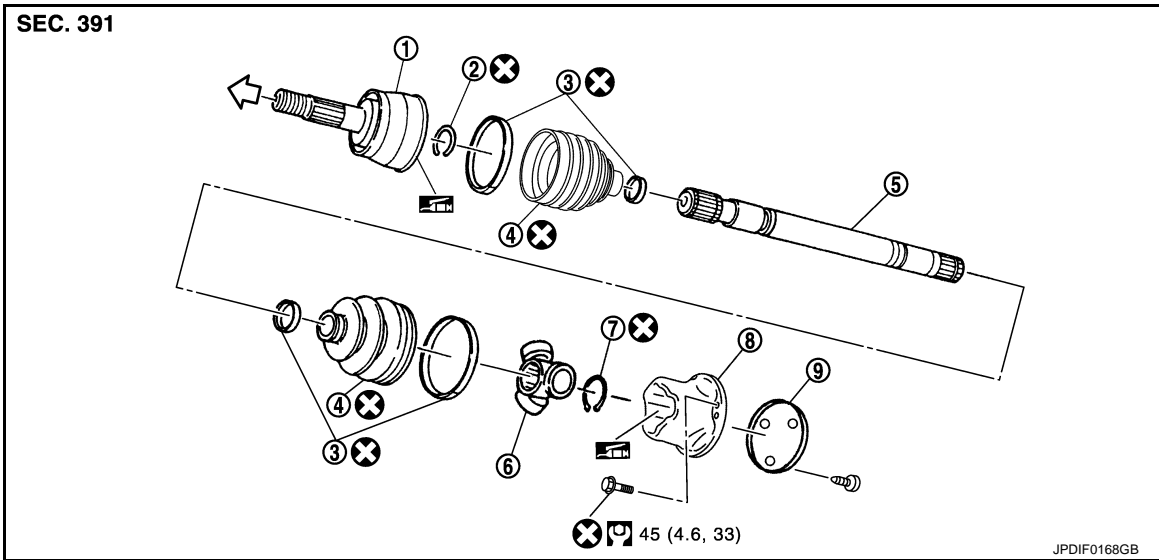

- | | | |
|-----------------------|------------------|--------------------|
| 1. Joint sub-assembly | 2. Circular clip | 3. Boot band |
| 4. Boot | 5. Shaft | 6. Spider assembly |
| 7. Snap ring | 8. Housing | 9. Plug |

←: Wheel side

NISSAN genuine grease or an equivalent.

Refer to [GI-4. "Components"](#) for symbols not described on the above.

RIGHT SIDE

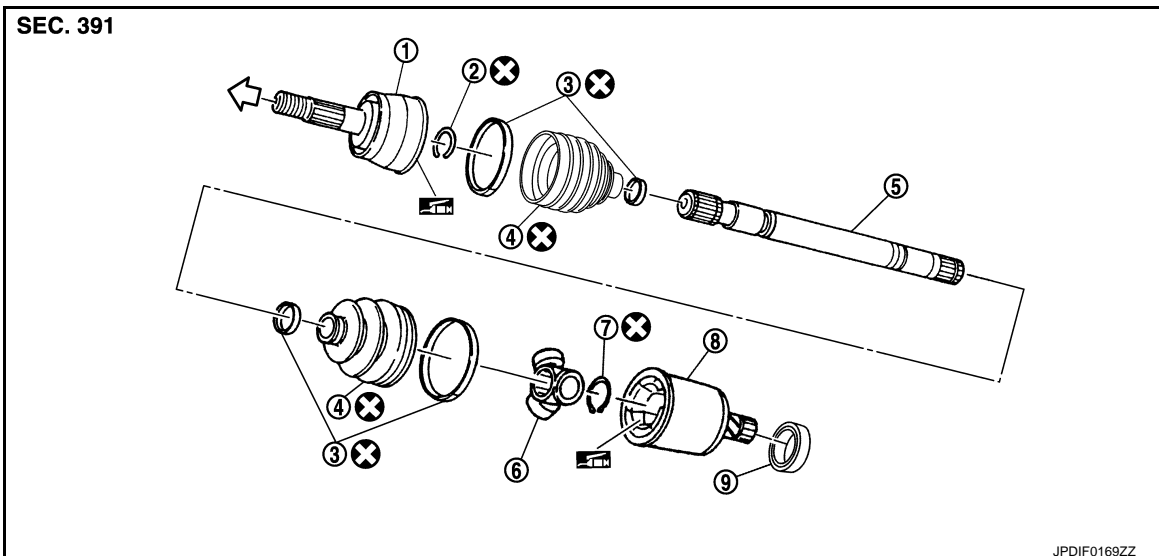

- | | | |
|-----------------------|------------------|--------------------|
| 1. Joint sub-assembly | 2. Circular clip | 3. Boot band |
| 4. Boot | 5. Shaft | 6. Spider assembly |
| 7. Snap ring | 8. Housing | 9. Dust shield |

←: Wheel side

A
B
C
FAX
E
F
G
H
I
J
K
L
M
N
O
P

FRONT DRIVE SHAFT BOOT

< REMOVAL AND INSTALLATION >

[AWD]

: NISSAN genuine grease or an equivalent.

Refer to [GI-4, "Components"](#) for symbols not described on the above.

WHEEL SIDE

WHEEL SIDE : Removal and Installation

INFOID:000000004343108

REMOVAL

1. Remove tires with power tool.
2. Remove wheel sensor and sensor harness. Refer to [BRC-108, "FRONT WHEEL SENSOR : Exploded View"](#).

CAUTION:

Never pull on wheel sensor harness.

3. Remove brake hose bracket. Refer to [BR-20, "FRONT : Exploded View"](#).
4. Remove caliper assembly. Hang caliper assembly in a place where it will not interfere with work. Refer to [BR-34, "BRAKE CALIPER ASSEMBLY : Exploded View"](#).

CAUTION:

Never depress brake pedal while brake caliper is removed.

5. Remove disc rotor. Refer to [BR-35, "BRAKE CALIPER ASSEMBLY : Removal and Installation"](#).
6. Remove cotter pin, and then loosen wheel hub lock nut with a power tool. Refer to [FAX-17, "Exploded View"](#).
7. Patch wheel hub lock nut with a piece of wood. Hammer the wood to disengage wheel hub and bearing assembly from drive shaft.

CAUTION:

- **Never place drive shaft joint at an extreme angle. Also be careful not to overextend slide joint.**
- **Never allow drive shaft to hang down without support for joint sub-assembly, shaft and the other parts.**

NOTE:

Use suitable puller if wheel hub and bearing assembly and drive shaft cannot be separated even after performing the above procedure.

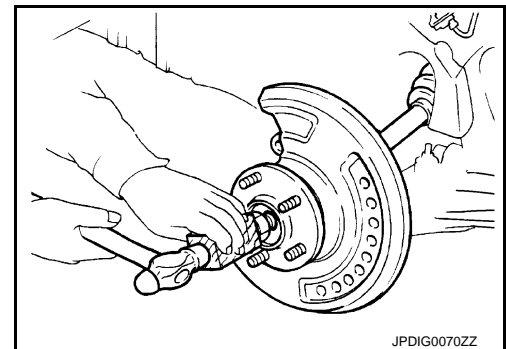

8. Remove wheel hub lock nut.
9. Remove steering outer socket. Refer to [ST-33, "AWD : Exploded View"](#).
10. Remove cotter pin of transverse link and steering knuckle, and then loosen nut. Refer to [FAX-17, "Exploded View"](#).

11. Separate steering knuckle from transverse link so as not to damage ball joint boot using the ball joint remover.

CAUTION:

Temporarily tighten the nut to prevent damage to threads and to prevent the ball joint remover from suddenly coming off.

12. Remove drive shaft from wheel hub and bearing assembly.
13. Remove boot bands, and then remove boot from joint sub-assembly.
14. Screw drive shaft puller (A) (commercial service tool) 30 mm (1.18 in) or more into the thread of joint sub-assembly, and remove joint sub-assembly from shaft.

CAUTION:

- **Align a sliding hammer and drive shaft and remove them by pulling firmly and uniformly.**
- **If joint sub-assembly cannot be pulled out, try after removing drive shaft from vehicle.**

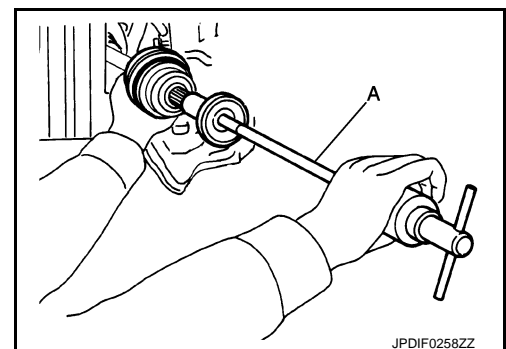

FRONT DRIVE SHAFT BOOT

[AWD]

< REMOVAL AND INSTALLATION >

15. Remove circular clip (1) from shaft.
16. Remove boot from shaft.

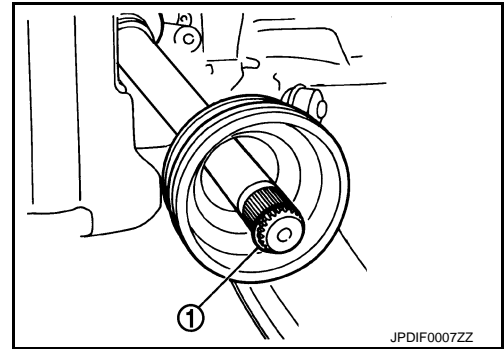

INSTALLATION

1. Clean the old grease on joint sub-assembly with paper waste.
2. Fill serration slot joint sub-assembly (1) with NISSAN genuine grease or equivalent until the serration slot and ball groove become full to the brim.

CAUTION:

After applying grease, use a paper waste to wipe off old grease that has oozed out.

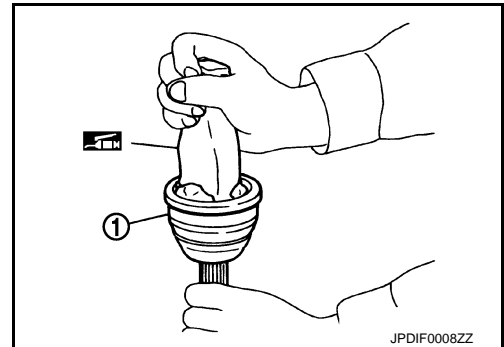

3. Install boot and boot bands to shaft.

CAUTION:

- Wrap serration on shaft with tape (A) to protect the boot from damage.
- Never reuse boot and boot band.

4. Remove the tape wrapped around the serration on shaft.

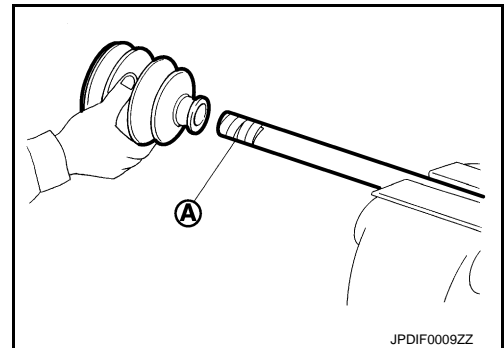

5. Position circular clip (1) on groove at the shaft edge.

CAUTION:

Never reuse circular clip.

NOTE:

Drive joint inserter is recommended when installing circular clip.

6. Align both center axes of the shaft edge and joint sub-assembly.

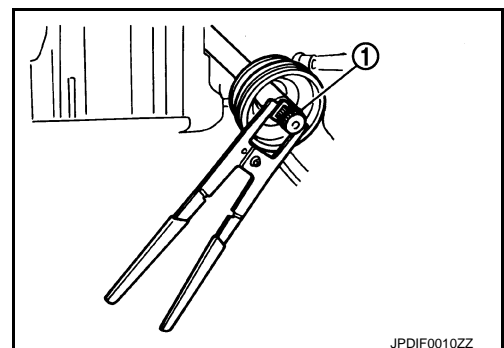

A
B
C
FAX
E
F
G
H
I
J
K
L
M
N
O
P

FRONT DRIVE SHAFT BOOT

[AWD]

< REMOVAL AND INSTALLATION >

7. Install joint sub-assembly (1) to shaft using plastic hammer.

CAUTION:

Confirm that joint sub-assembly is correctly engaged while rotating drive shaft.

8. Fill serration slot joint sub-assembly with NISSAN genuine grease or equivalent until the serration slot and ball groove become full to the brim.

Standard

Grease amount : Refer to [FAX-32, "Drive Shaft"](#).

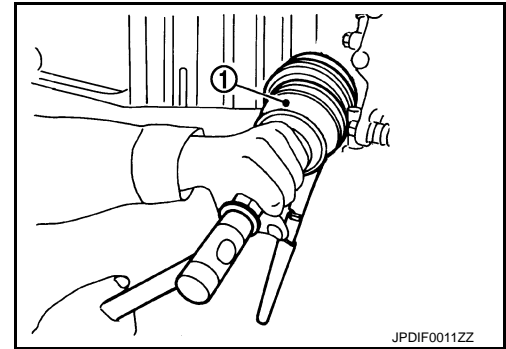

9. Install the boot securely into grooves (indicated by "*" marks) shown in the figure.

CAUTION:

If grease adheres to the boot mounting surface (indicated by "*" mark) on the shaft or joint sub-assembly, boot may come off. Remove all grease from the surface.

10. To prevent the deformation of the boot, adjust the boot installation length (L) to the specified value shown below by inserting the suitable tool into inside of the boot from the large diameter side of the boot and discharging the inside air.

Standard

L : Refer to [FAX-32, "Drive Shaft"](#).

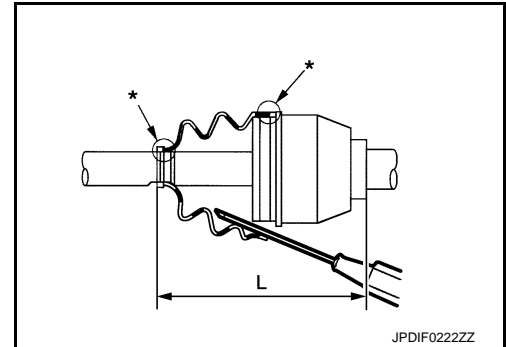

CAUTION:

- If the boot installation length is outside the standard, it may cause breakage of boot.
- Be careful not to touch the inside of the boot with a tip of tool.

11. Secure the ends of the boot with boot bands using the boot band crimping tool (A) [SST: KV40107300 (-)].

CAUTION:

Never reuse boot band.

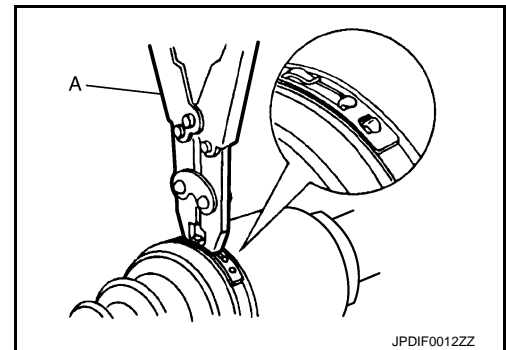

NOTE:

Secure boot band so that dimension (M) meets the specification as shown in the figure.

M : 2.0 – 3.0 mm (0.079 – 0.118 in)

12. Secure joint sub-assembly and shaft, and then make sure that they are in the correct position when rotating boot. Install them with boot band when boot installation positions become incorrect.

CAUTION:

Never reuse boot band.

13. Insert drive shaft to wheel hub and bearing assembly, and then temporarily tighten wheel hub lock nut.

CAUTION:

- The drive shaft is press-fit. When assembling the shaft, never press it, but pull it until fully seated by tightening the wheel hub lock nut.

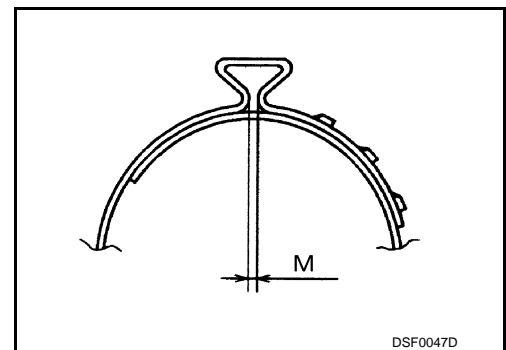

FRONT DRIVE SHAFT BOOT

[AWD]

< REMOVAL AND INSTALLATION >

- Check that anticorrosive oil is applied to the thread of the drive shaft. If not, apply appropriate oil such as engine oil.
 - If sufficient oil is not applied to the thread of the drive shaft, the wheel hub lock nut may be seized and the tightening torque reaches the specified limit prematurely. It may cause looseness or abnormal noises.
14. Install steering outer socket to steering knuckle. Refer to [ST-33, "AWD : Exploded View"](#).
15. Tighten the wheel hub lock nut to the specified torque, and install cotter pin. Refer to [FAX-17, "Exploded View"](#).
- CAUTION:**
- Never reuse cotter pin.
 - Bend it at the root sufficiently to prevent any looseness.
16. Install disc rotor. Refer to [BR-35, "BRAKE CALIPER ASSEMBLY : Removal and Installation"](#).
17. Install caliper assembly to steering knuckle. Refer to [BR-34, "BRAKE CALIPER ASSEMBLY : Exploded View"](#).
18. Install brake hose bracket to steering knuckle. Refer to [BR-20, "FRONT : Exploded View"](#).
19. Install wheel sensor to steering knuckle. Refer to [BRC-108, "FRONT WHEEL SENSOR : Exploded View"](#).

FINAL DRIVE SIDE

FINAL DRIVE SIDE : Removal and Installation

INFOID:000000004343109

NOTE:

Remove boot after removing drive shaft. Refer to [FAX-25, "LEFT SIDE : Removal and Installation"](#) (left side), [FAX-25, "RIGHT SIDE : Removal and Installation"](#) (right side).

Inspection

INFOID:000000004343110

INSPECTION AFTER REMOVAL

- Move joint up/down, left/right, and in the axial directions. Check for motion that is not smooth and for significant looseness.
- Check boot for cracks, damage, and leakage of grease.
- Disassemble drive shaft and exchange malfunctioning part if there is a non-standard condition.

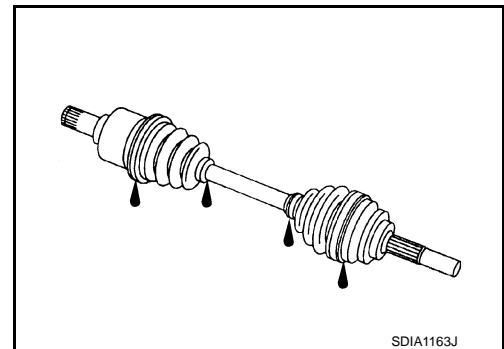

FRONT DRIVE SHAFT

< REMOVAL AND INSTALLATION >

[AWD]

FRONT DRIVE SHAFT

Exploded View

INFOID:000000004932986

LEFT SIDE

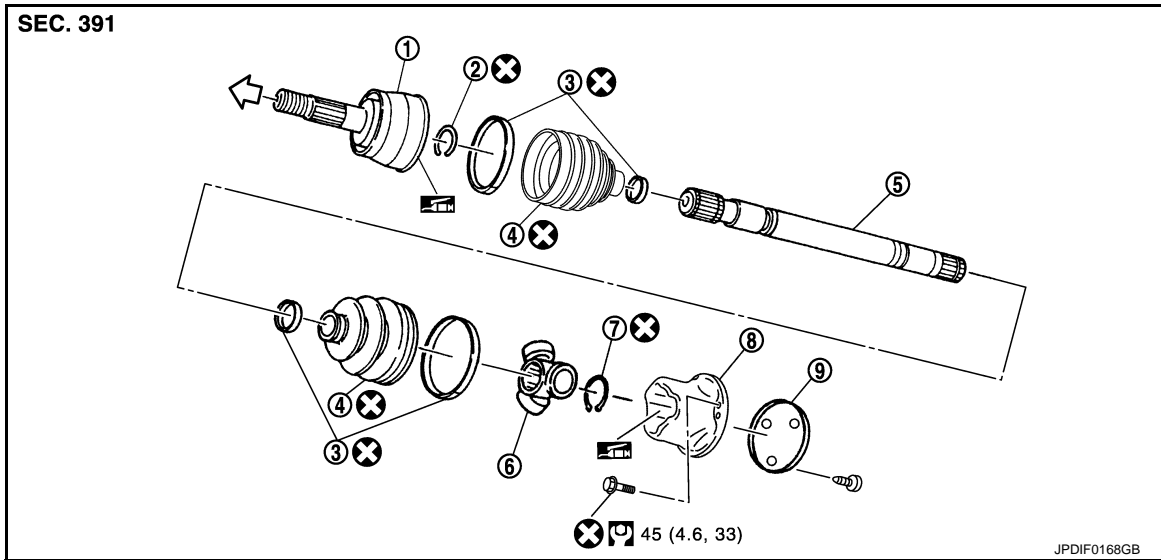

- | | | |
|-----------------------|------------------|--------------------|
| 1. Joint sub-assembly | 2. Circular clip | 3. Boot band |
| 4. Boot | 5. Shaft | 6. Spider assembly |
| 7. Snap ring | 8. Housing | 9. Plug |

↔: Wheel side

: NISSAN genuine grease or an equivalent.

Refer to [GI-4, "Components"](#) for symbols not described on the above.

RIGHT SIDE

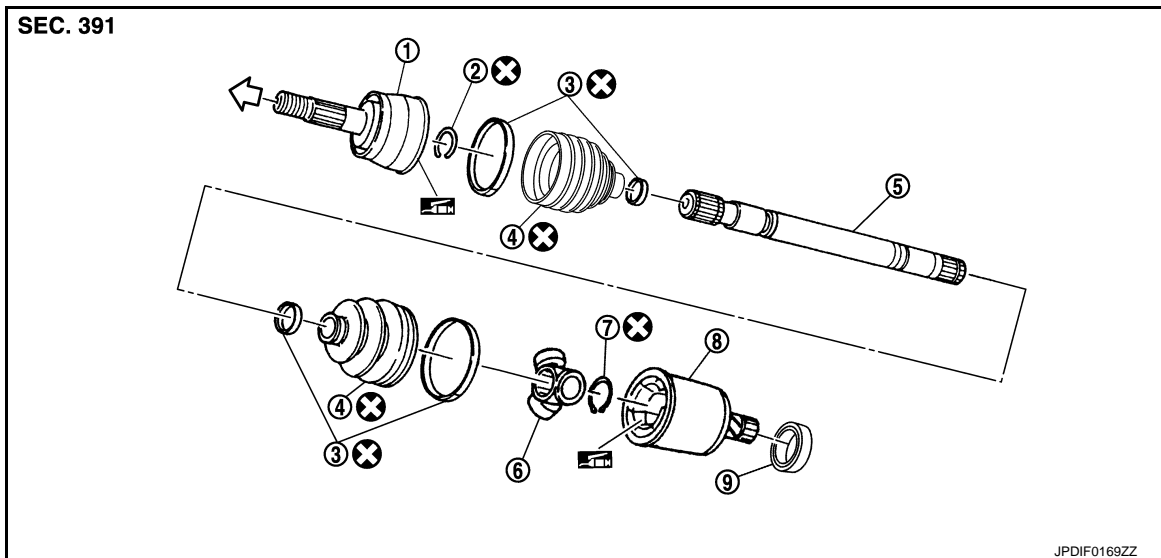

- | | | |
|-----------------------|------------------|--------------------|
| 1. Joint sub-assembly | 2. Circular clip | 3. Boot band |
| 4. Boot | 5. Shaft | 6. Spider assembly |
| 7. Snap ring | 8. Housing ring | 9. Dust shield |

↔: Wheel side

FRONT DRIVE SHAFT

< REMOVAL AND INSTALLATION >

[AWD]

: NISSAN genuine grease or an equivalent.

Refer to [GI-4, "Components"](#) for symbols not described on the above.

LEFT SIDE

LEFT SIDE : Removal and Installation

INFOID:000000004343112

REMOVAL

1. Remove tires with power tool.
2. Remove wheel sensor and sensor harness. Refer to [BRC-108, "FRONT WHEEL SENSOR : Exploded View"](#).
CAUTION:
Never pull on wheel sensor harness.
3. Remove brake hose bracket. Refer to [BR-20, "FRONT : Exploded View"](#).
4. Remove caliper assembly. Hang caliper assembly in a place where it will not interfere with work. Refer to [BR-34, "BRAKE CALIPER ASSEMBLY : Exploded View"](#).
CAUTION:
Never depress brake pedal while brake caliper is removed.
5. Remove disc rotor. Refer to [BR-35, "BRAKE CALIPER ASSEMBLY : Removal and Installation"](#).
6. Remove cotter pin, and then loosen wheel hub lock nut with a power tool. Refer to [FAX-17, "Exploded View"](#).
7. Patch wheel hub lock nut with a piece of wood. Hammer the wood to disengage wheel hub and bearing assembly from drive shaft.
CAUTION:
 - **Never place drive shaft joint at an extreme angle. Also be careful not to overextend slide joint.**
 - **Never allow drive shaft to hang down without support for joint sub-assembly, shaft and the other parts.****NOTE:**
Use suitable puller if wheel hub and bearing assembly and drive shaft cannot be separated even after performing the above procedure.
8. Remove wheel hub lock nut.
9. Remove steering outer socket. Refer to [ST-33, "AWD : Exploded View"](#).
10. Remove drive shaft from wheel hub and bearing assembly.
11. Remove mounting bolts, and then remove drive shaft from vehicle.

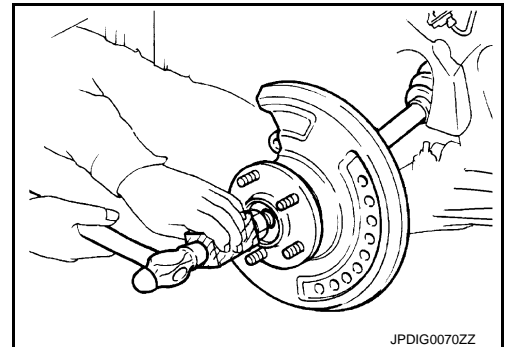

INSTALLATION

Install in the reverse order of removal.

RIGHT SIDE

RIGHT SIDE : Removal and Installation

INFOID:000000004343113

REMOVAL

1. Remove tires with power tool.
2. Remove wheel sensor and sensor harness. Refer to [BRC-108, "FRONT WHEEL SENSOR : Exploded View"](#).
CAUTION:
Never pull on wheel sensor harness.
3. Remove brake hose bracket. Refer to [BR-20, "FRONT : Exploded View"](#).
4. Remove caliper assembly. Hang caliper assembly in a place where it will not interfere with work. Refer to [BR-34, "BRAKE CALIPER ASSEMBLY : Exploded View"](#).
CAUTION:
Never depress brake pedal while brake caliper is removed.
5. Remove disc rotor. Refer to [BR-35, "BRAKE CALIPER ASSEMBLY : Removal and Installation"](#).

A

B

C

FAX

E

F

G

H

I

J

K

L

M

N

O

P

FRONT DRIVE SHAFT

[AWD]

< REMOVAL AND INSTALLATION >

6. Remove cotter pin, and then loosen wheel hub lock nut with a power tool. Refer to [FAX-17. "Exploded View"](#).
7. Patch wheel hub lock nut with a piece of wood. Hammer the wood to disengage wheel hub and bearing assembly from drive shaft.

CAUTION:

- Never place drive shaft joint at an extreme angle. Also be careful not to overextend slide joint.
- Never allow drive shaft to hang down without support for joint sub-assembly, shaft and the other parts.

NOTE:

Use suitable puller if wheel hub and bearing assembly and drive shaft cannot be separated even after performing the above procedure.

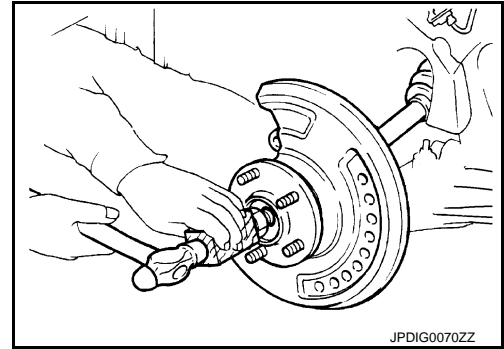

8. Remove wheel hub lock nut.
9. Remove steering outer socket. Refer to [ST-33. "AWD : Exploded View"](#).
10. Remove drive shaft from wheel hub and bearing assembly.

11. Remove drive shaft from front final drive using the drive shaft attachment (A) [SST:KV40107500 (-)] and a sliding hammer (B) (commercial service tool) while inserting tip of the drive shaft attachment between housing and front final drive.

CAUTION:

Never place drive shaft joint at an extreme angle when removing drive shaft. Also be careful not to overextend slide joint.

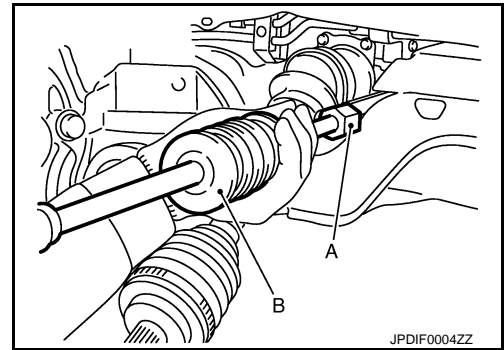

INSTALLATION

Note the following, and install in the reverse order of removal.

CAUTION:

Always replace final drive oil seal with new one when installing drive shaft. Refer to [DLN-46. "Exploded View"](#).

- Place the protector (A) [SST:KV38107900 (-)] onto final drive to prevent damage to the oil seal while inserting drive shaft. Slide drive shaft sliding joint and tap with a hammer to install securely.

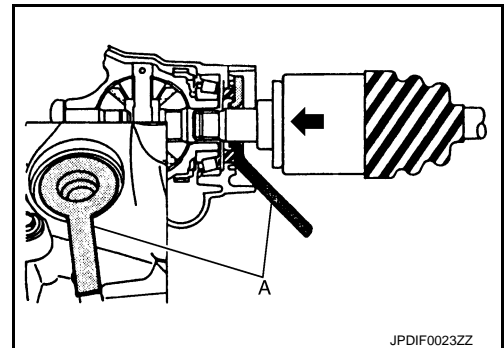

WHEEL SIDE

WHEEL SIDE : Disassembly and Assembly

INFOID:000000004343114

DISASSEMBLY

1. Fix shaft with a vise.

CAUTION:

Protect shaft when fixing with a vise using aluminum or copper plates.

2. Remove boot bands, and then remove boot from joint sub-assembly.

FRONT DRIVE SHAFT

[AWD]

< REMOVAL AND INSTALLATION >

3. Screw drive shaft puller (A) (commercial service tool) 30 mm (1.18 in) or more into the thread of joint sub-assembly, and remove joint sub-assembly from shaft.

CAUTION:

- If joint sub-assembly cannot be removed after five or more unsuccessful attempts, replace shaft and joint sub-assembly as a set.
- Align sliding hammer and drive shaft and remove them by pulling directory.

4. Remove circular clip from shaft.
5. Remove boot from shaft.
6. Clean old grease on joint sub-assembly with paper waste while rotating ball cage.

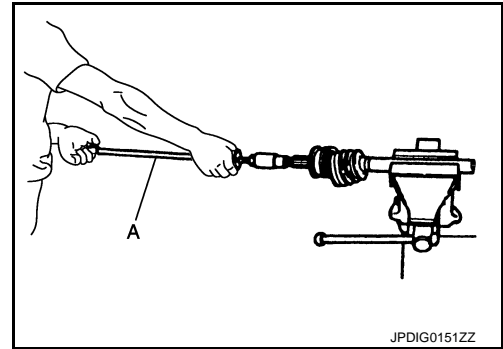

ASSEMBLY

1. Clean the old grease on joint sub-assembly with paper waste.
2. Fill serration slot joint sub-assembly (1) with NISSAN genuine grease or equivalent until the serration slot and ball groove become full to the brim.

CAUTION:

After applying grease, use a paper waste to wipe off old grease that has oozed out.

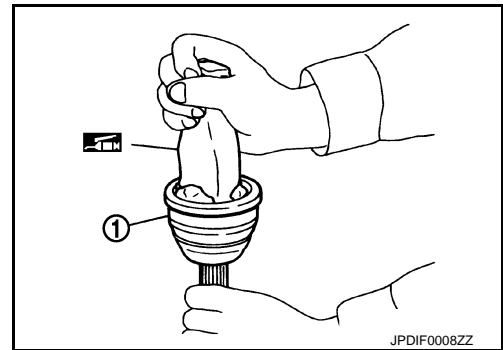

3. Install boot and boot bands to shaft.
CAUTION:
 - Wrap serration on shaft with tape (A) to protect the boot from damage.
 - Never reuse boot and boot band.

4. Remove the tape wrapped around the serration on shaft.
5. Position circular clip on groove at the shaft edge.

CAUTION:

Never reuse circular clip.

NOTE:

Drive joint inserter is recommended when installing circular clip.

6. Align both center axles of the shaft edge and joint sub-assembly. Then assemble shaft with circular clip joint sub-assembly.

7. Install joint sub-assembly (1) to shaft using plastic hammer.

CAUTION:

Confirm that joint sub-assembly is correctly engaged while rotating drive shaft.

8. Apply the balance of the specified amount of grease into the boot inside from large diameter side of boot.

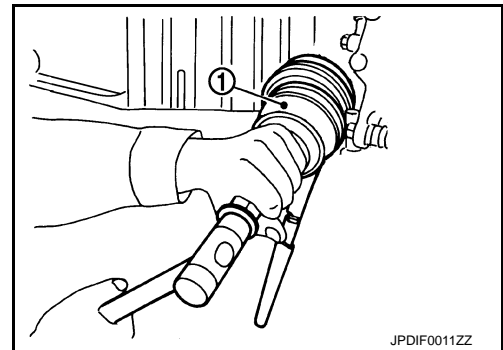
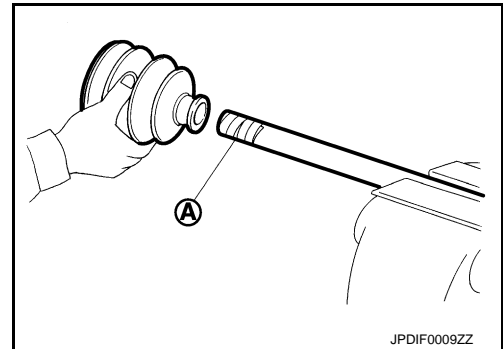

Standard

Grease amount : Refer to [FAX-32, "Drive Shaft"](#).

FRONT DRIVE SHAFT

[AWD]

< REMOVAL AND INSTALLATION >

9. Install the boot securely into grooves (indicated by "*" marks) shown in the figure.

CAUTION:

If grease adheres to the boot mounting surface (indicated by "*" mark) on the shaft or joint sub-assembly, boot may come off. Remove all grease from the surface.

10. To prevent the deformation of the boot, adjust the boot installation length (L) to the specified value shown below by inserting the suitable tool into inside of the boot from the large diameter side of the boot and discharging the inside air.

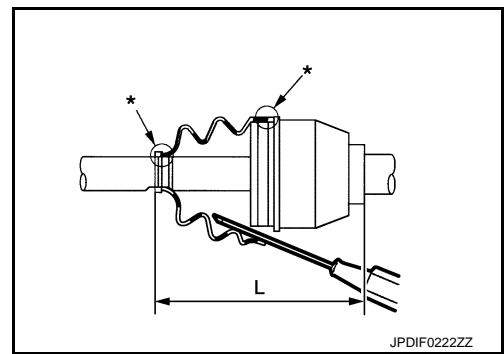

Standard

L : Refer to [FAX-32, "Drive Shaft"](#).

CAUTION:

- If the boot installation length is outside the standard, it may cause breakage of the boot.
- Be careful not to touch the inside of the boot with a tip of tool.

11. Secure the ends of the boot with boot bands using the boot band crimping tool (A) [SST: KV40107300 (-)].

CAUTION:

Never reuse boot band.

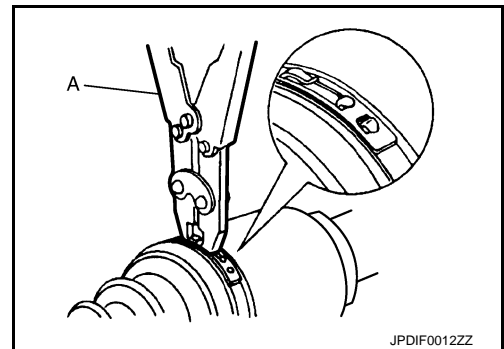

NOTE:

Secure boot band so that dimension (M) meets the specification as shown in the figure.

M : **2.0 – 3.0 mm (0.079 – 0.118 in)**

12. Secure joint sub-assembly and shaft, and then make sure that they are in the correct position when rotating boot. Install them with boot band when boot installation positions become incorrect.

CAUTION:

Never reuse boot band.

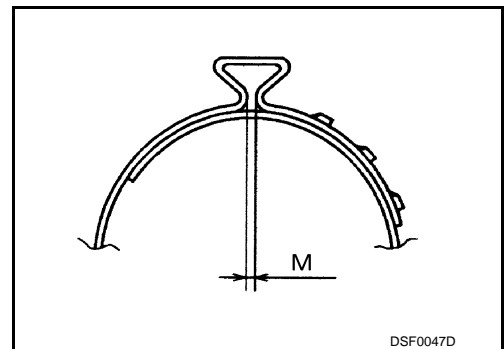

FINAL DRIVE SIDE

FINAL DRIVE SIDE : Disassembly and Assembly

INFOID:000000004343115

DISASSEMBLY

1. Fix shaft with a vise.

CAUTION:

Protect shaft when fixing with a vise using aluminum or copper plates.

2. Remove boot bands, and then remove boot from housing.
3. Put matching marks on housing and shaft, and then pull out housing from shaft.

CAUTION:

Use paint or similar substance for matching marks. Never scratch the surfaces.

FRONT DRIVE SHAFT

[AWD]

< REMOVAL AND INSTALLATION >

- Put matching marks (A) on the spider assembly and shaft.

CAUTION:

Use paint or similar substance for matching marks. Never scratch the surfaces.

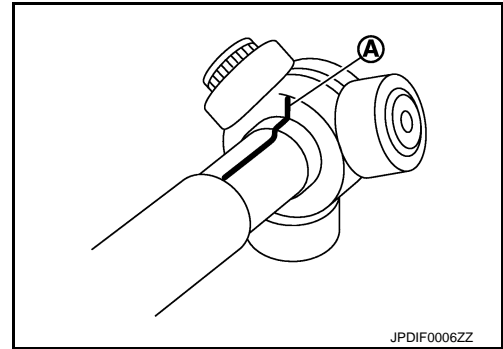

- Remove snap ring (1), and then remove spider assembly from the shaft.
- Remove boot from the shaft.
- Remove plug from housing. (Left side)
- Remove dust shield from housing. (Right side)

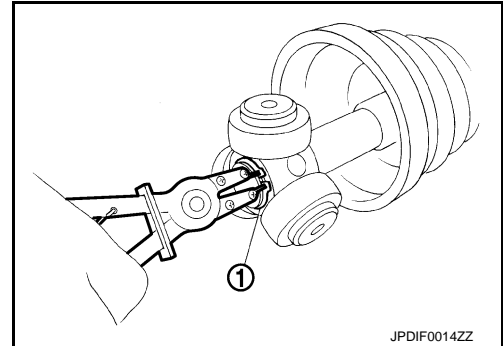

ASSEMBLY

- Clean old grease on housing with paper waste.
- Plug (1) has been removed. Install a plug to housing (2) with a screw. (Left side)
- Install dust shield to housing. (Right side)

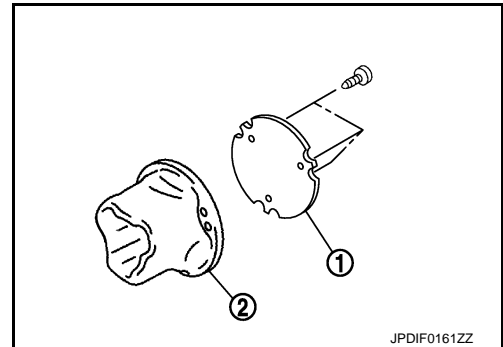

- Wrap serration on shaft with tape (A) to protect boot from damage. Install boot and boot bands to shaft.
CAUTION:
Never reuse boot and boot band.
- Remove the tape wrapped around the serration on shaft.

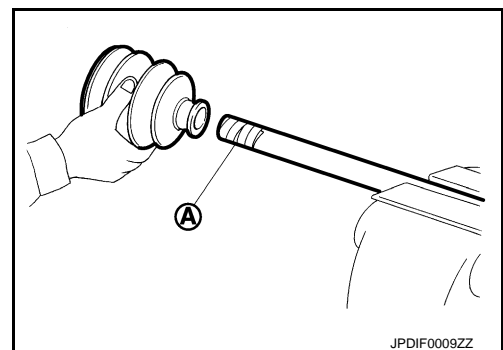

A
B
C
FAX
E
F
G
H
I
J
K
L
M
N
O
P

FRONT DRIVE SHAFT

[AWD]

< REMOVAL AND INSTALLATION >

6. Install the spider assembly (1), align it with the matching marks (A) on the shaft (2) during the removal, and direct the serration mounting surface (B) to the shaft.

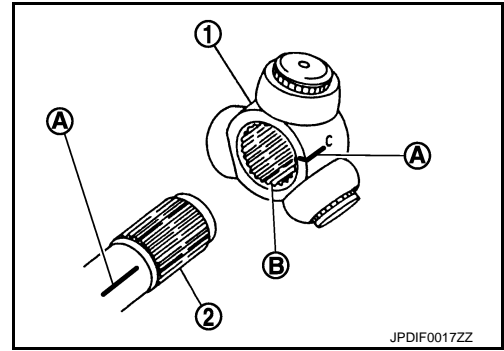

7. Secure spider assembly onto shaft with snap ring (1).
CAUTION:
Never reuse snap ring.
8. Apply the appropriate amount of grease to spider assembly and sliding surface.
9. Assemble the housing onto spider assembly, and apply the balance of the specified amount grease.

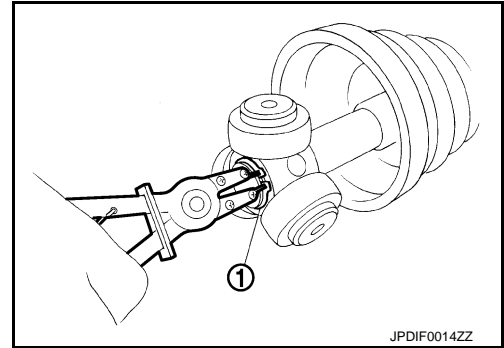

Standard

Grease amount : Refer to [FAX-32, "Drive Shaft"](#).

10. Align matching marks painted when housing was removed.
11. Install the boot securely into grooves (indicated by "*" marks) shown in the figure.

CAUTION:

If grease adheres to the boot mounting surface (indicated by "*" mark) on shaft or housing, boot may come off. Remove all grease from the surface.

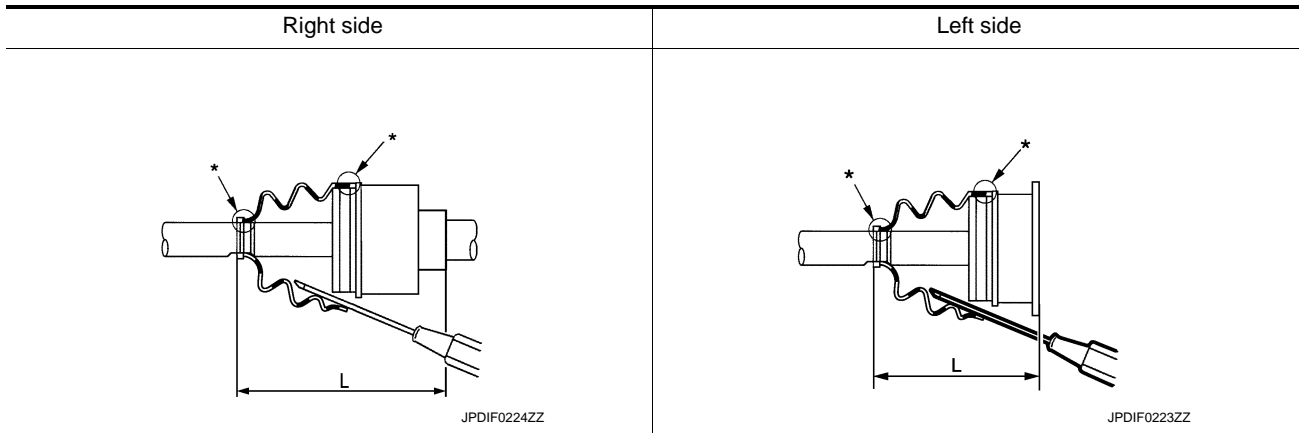

12. To prevent the deformation of the boot, adjust the boot installation length (L) to the value shown below by inserting the suitable tool into the inside of boot from the large diameter side of boot and discharging inside air.

Standard

L : Refer to [FAX-32, "Drive Shaft"](#).

CAUTION:

- If the boot installation length is outside the standard, it may cause breakage of the boot.
- Be careful not to touch the inside of the boot with the tip of tool.

13. Install boot bands securely.

CAUTION:

Never reuse boot band.

FRONT DRIVE SHAFT

[AWD]

< REMOVAL AND INSTALLATION >

- a. Put boot band in the groove on drive shaft boot. Then fit pawls (←) into holes to temporary installation.

NOTE:

For the large diameter side, fit projection (A) and guide slit (B) at first.

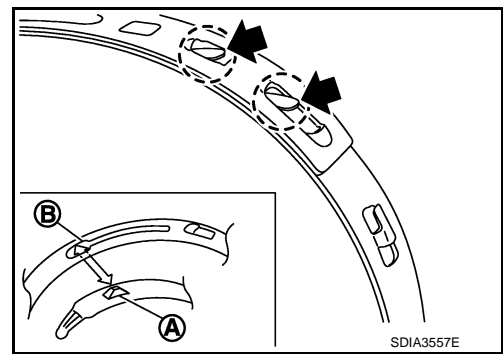

- b. Pinch projection on the band with suitable pliers to tighten band.
c. Insert tip of band below end of the pawl.
14. Secure housing and shaft, and then make sure that they are in the correct position when rotating boot. Install them with boot band when the mounting positions become incorrect.

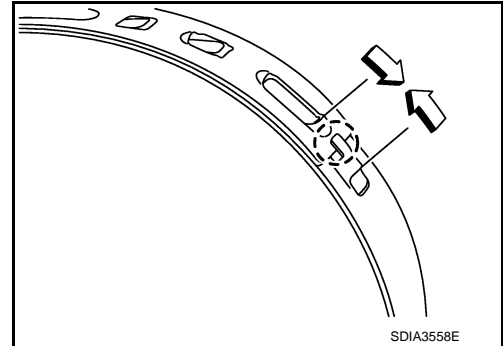

Inspection

INFOID:000000004343116

INSPECTION AFTER REMOVAL

- Move joint up/down, left/right, and in the axial directions. Check for motion that is not smooth and for significant looseness.
- Check boot for cracks, damage, and leakage of grease.
- Disassemble drive shaft and exchange malfunctioning part if there is a non-standard condition.

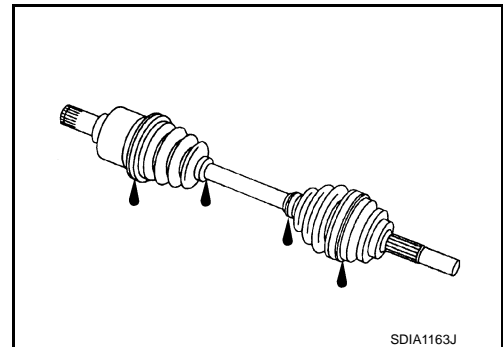

INSPECTION AFTER DISASSEMBLY

Shaft

Check shaft for runout, cracks, or other damage. Replace it if necessary.

Joint Sub-Assembly (Wheel Side)

Check the following items, replace the parts if necessary.

- Joint sub-assembly for rough rotation and excessive axial looseness.
 - The inside of the joint sub-assembly for entry of foreign material.
 - Joint sub-assembly for compression scars, cracks, and fractures inside of joint sub-assembly.
- Replace joint sub-assembly if there are any non-standard conditions of components.

Housing and Spider assembly (Final Drive side)

Replace housing and spider assembly if there is scratching or wear of housing roller contact surface or spider roller contact surface.

NOTE:

Housing and spider assembly are used in a set.

A

B

C

FAX

E

F

G

H

I

J

K

L

M

N

O

P

SERVICE DATA AND SPECIFICATIONS (SDS)

< SERVICE DATA AND SPECIFICATIONS (SDS)

[AWD]

SERVICE DATA AND SPECIFICATIONS (SDS)

SERVICE DATA AND SPECIFICATIONS (SDS)

Wheel Bearing

INFOID:000000004343117

Item	Standard
Axial end play	0.05 mm (0.002 in) or less

Drive Shaft

INFOID:000000004343118

Item	Left side		Right side	
	Wheel side	Final drive side	Wheel side	Final drive side
Grease quantity	Wheel side	77 – 97 g (2.72 – 3.42 oz)		
	Final drive side	95 – 105 g (3.36 – 3.70 oz)	113 – 123 g (3.99 – 4.33 oz)	
Boots installed length	Wheel side	136 mm (5.35 in)		
	Final drive side	152 mm (5.98 in)	158.6 mm (6.24 in)	