

SECTION **RSU**
 REAR SUSPENSION

A
B
C
D

RSU

CONTENTS

SYMPTOM DIAGNOSIS	2	Disposal	11	F
NOISE, VIBRATION AND HARSHNESS (NVH) TROUBLESHOOTING	2	SUSPENSION ARM	12	G
NVH Troubleshooting Chart	2	Exploded View	12	
PRECAUTION	3	Removal and Installation	12	
PRECAUTIONS	3	Inspection	12	
Precautions for Suspension	3	RADIUS ROD	14	H
PREPARATION	4	Exploded View	14	
PREPARATION	4	Removal and Installation	14	
Special Service Tool	4	Inspection	14	I
Commercial Service Tool	4	FRONT LOWER LINK	15	J
PERIODIC MAINTENANCE	5	Exploded View	15	
REAR SUSPENSION ASSEMBLY	5	Removal and Installation	15	
Inspection	5	Inspection	15	
WHEEL ALIGNMENT	6	REAR STABILIZER	16	K
Inspection	6	Exploded View	16	
Adjustment	6	Removal and Installation	16	
REMOVAL AND INSTALLATION	8	Inspection	16	L
REAR LOWER LINK & COIL SPRING	8	UNIT REMOVAL AND INSTALLATION	17	M
Exploded View	8	REAR SUSPENSION MEMBER	17	
Removal and Installation	8	Exploded View	17	
Inspection	9	Removal and Installation	17	
REAR SHOCK ABSORBER	10	Inspection	18	N
Exploded View	10	SERVICE DATA AND SPECIFICATIONS (SDS)	19	O
Removal and Installation	10	SERVICE DATA AND SPECIFICATIONS (SDS)	19	
Disassembly and Assembly	10	Wheel Alignment	19	
Inspection	11	Ball Joint	19	P
		Wheelarch Height	19	

NOISE, VIBRATION AND HARSHNESS (NVH) TROUBLESHOOTING

< SYMPTOM DIAGNOSIS >

SYMPTOM DIAGNOSIS

NOISE, VIBRATION AND HARSHNESS (NVH) TROUBLESHOOTING

NVH Troubleshooting Chart

INFOID:000000004347313

Use chart below to find the cause of the symptom. If necessary, repair or replace these parts.

Symptom		Possible cause and SUSPECTED PARTS		Reference page													
				RSU-8, RSU-10, RSU-12, RSU-14, RSU-15, RSU-16, RSU-17	RSU-11	—	—	—	RSU-8, RSU-10, RSU-12, RSU-14, RSU-15, RSU-16, RSU-17	RSU-16	NVH in DLN section.	NVH in DLN section.	NVH in RAX and RSU sections.	NVH in WT section.	NVH in WT section.	NVH in RAX section.	NVH in BR section.
REAR SUSPENSION	Noise	x	x	x	x	x	x			x	x	x	x	x	x	x	x
	Shake	x	x	x	x		x			x		x	x	x	x	x	x
	Vibration	x	x	x	x	x				x		x		x			x
	Shimmy	x	x	x	x			x				x	x	x		x	x
	Judder	x	x	x								x	x	x		x	x
	Poor quality ride or handling	x	x	x	x	x		x	x			x	x	x			

x: Applicable

PRECAUTIONS

< PRECAUTION >

PRECAUTION

PRECAUTIONS

Precautions for Suspension

INFOID:000000004347314

- When installing rubber bushings, the final tightening must be carried out under unladen conditions with tires on ground. Spilled oil might shorten the life of rubber bushings. Be sure to wipe off any spilled oil.
- Unladen conditions mean that fuel, engine coolant and lubricant are full. Spare tire, jack, hand tools and mats are in designated positions.
- After servicing suspension parts, be sure to check wheel alignment.
- Self-lock nuts are not reusable. Always use new ones when installing. Since new self-lock nuts are pre-oiled, tighten as they are.

A

B

C

D

RSU

F

G

H

I

J

K

L

M

N

O

P

PREPARATION

< PREPARATION >

PREPARATION

PREPARATION

Special Service Tool

INFOID:000000004347315

The actual shapes of Kent-Moore tools may differ from those of special service tools illustrated here.

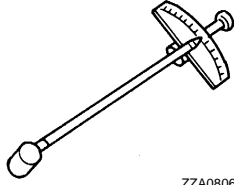
Tool number (Kent-Moore No.) Tool name	Description
ST3127S000 (J-25765-A) Preload gauge  ZZA0806D	Measuring rotating torque of ball joint

Commercial Service Tool

INFOID:000000004347316

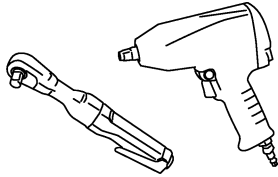
Tool name	Description
Power tool  PBIC0190E	Loosening bolts and nuts

REAR SUSPENSION ASSEMBLY

< PERIODIC MAINTENANCE >

PERIODIC MAINTENANCE

REAR SUSPENSION ASSEMBLY

Inspection

INFOID:000000004347317

MOUNTING INSPECTION

Make sure the mounting conditions (looseness, backlash) of each component and component conditions (wear, damage) are normal.

BALL JOINT AXIAL END PLAY

1. Place an iron bar or equivalent between lower link or upper link and axle housing.
2. Measure axial end play by playing it up and down.

Standard

Axial end play : Refer to [RSU-19, "Ball Joint"](#).

CAUTION:

- Never depress brake pedal when measuring.
- Never perform with tires on level ground.
- Be careful not to damage ball joint boot. never damage the installation position by applying excessive force.

SHOCK ABSORBER

Check for oil leakage and damage. Replace it if necessary.

A
B
C
D
E
F
G
H
I
J
K
L
M
N
O
P

RSU

WHEEL ALIGNMENT

< PERIODIC MAINTENANCE >

WHEEL ALIGNMENT

Inspection

INFOID:000000004347318

DESCRIPTION

Measure wheel alignment under unladen conditions.

NOTE:

"Unladen conditions" means that fuel, engine coolant, and lubricant are full. Spare tire, jack, hand tools and mats are in designated positions.

PRELIMINARY CHECK

Check the following:

- Tires for improper air pressure and wear.
- Road wheels for runout. Refer to [WT-99, "Inspection"](#).
- Wheel bearing axial end play. Refer to [RAX-6, "Inspection"](#).
- Ball joint axial end play of suspension arm. Refer to [RSU-19, "Ball Joint"](#).
- Shock absorber operation.
- Each mounting point of axle and suspension for looseness and deformation.
- Each of front lower link, rear lower link, radius rod, rear suspension member, suspension arm and shock absorber for cracks, deformation, and other damage.
- Vehicle height (posture).

GENERAL INFORMATION AND RECOMMENDATIONS

- A four-wheel thrust alignment should be performed.
- This type of alignment is recommended for any NISSAN/INFINITI vehicle.
- The four-wheel "thrust" process helps ensure that the vehicle is properly aligned and the steering wheel is centered.
- The alignment rack itself should be capable of accepting any NISSAN/INFINITI vehicle.
- The rack should be checked to ensure that it is level.
- Make sure the machine is properly calibrated.
- Your alignment equipment should be regularly calibrated in order to give correct information.
- Check with the manufacturer of your specific equipment for their recommended Service/Calibration Schedule.

ALIGNMENT PROCESS

IMPORTANT:

Use only the alignment specifications listed in this Service Manual.

- When displaying the alignment settings, many alignment machines use "indicators": (Green/red, plus or minus, Go/No Go). **Never not use these indicators.**
- The alignment specifications programmed into your machine that operate these indicators may not be correct.
- This may result in an ERROR.
- Some newer alignment machines are equipped with an optional "Rolling Compensation" method to "compensate" the sensors (alignment targets or head units). **Never use this "Rolling Compensation" method.**
- Use the "Jacking Compensation Method". After installing the alignment targets or head units, raise the vehicle and rotate the wheels 1/2 turn both ways.
- See Instructions in the alignment machine you're using for more information on this.

Adjustment

INFOID:000000004347319

CAMBER

WHEEL ALIGNMENT

< PERIODIC MAINTENANCE >

- If camber is exceeds the standard value, adjust with adjusting bolt (1) in front lower link (2).

Standard

Camber: Refer to [RSU-19, "Wheel Alignment"](#).

CAUTION:

After adjusting camber, be sure to check toe-in.

- If camber is not still within the specification, inspect and replace any damaged or worn suspension parts.

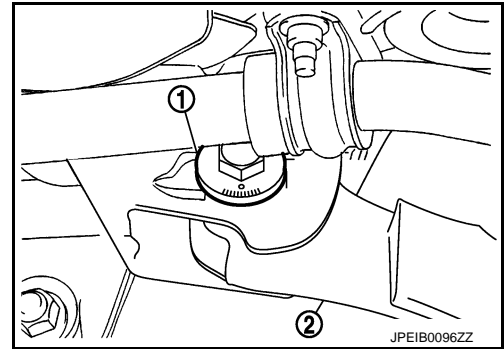

TOE-IN

- If toe-in is exceeds the standard value, adjust with adjusting bolt (1) in rear lower link (2).

Standard

Toe-In: Refer to [RSU-19, "Wheel Alignment"](#).

CAUTION:

Be sure to adjust equally on right and left side with adjusting bolt.

- If toe-in is not still within the specification, inspect and replace any damaged or worn suspension parts.

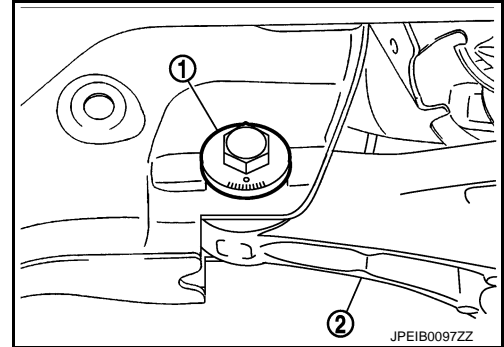

A
B
C
D
E
F
G
H
I
J
K
L
M
N
O
P

RSU

REAR LOWER LINK & COIL SPRING

< REMOVAL AND INSTALLATION >

REMOVAL AND INSTALLATION

REAR LOWER LINK & COIL SPRING

Exploded View

INFOID:000000004347320

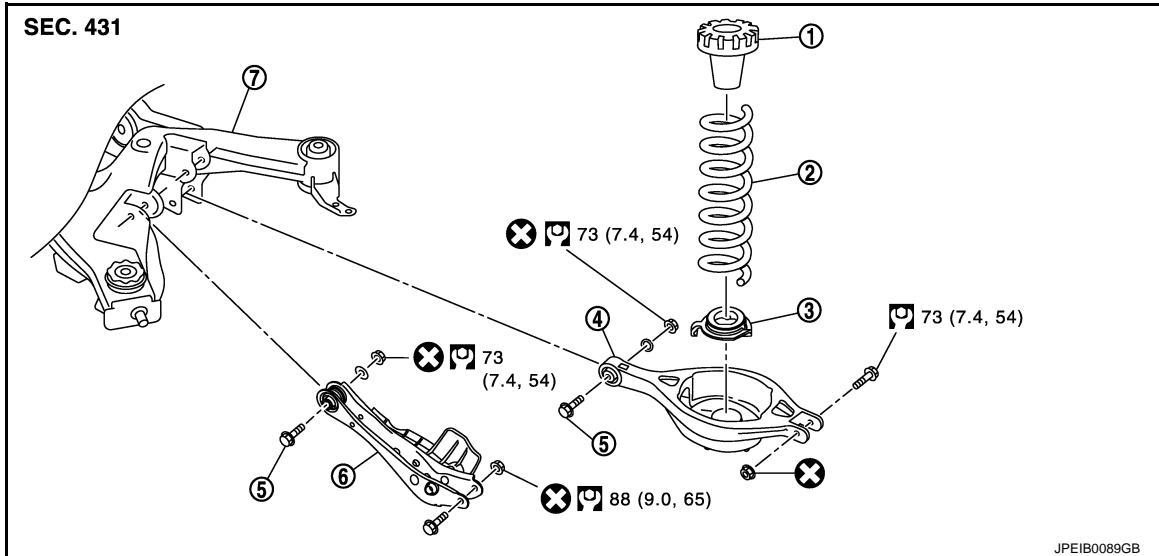

- | | | |
|---------------------------|-------------------|---------------------|
| 1. Upper seat | 2. Coil spring | 3. Rubber seat |
| 4. Rear lower link | 5. Adjusting bolt | 6. Front lower link |
| 7. Rear suspension member | | |

Refer to [GI-4, "Components"](#) for symbols in the figure.

Removal and Installation

INFOID:000000004347321

REMOVAL

1. Remove tires with power tool.
2. Set suitable jack under rear lower link to relieve the coil spring tension.
3. Loosen rear lower link mounting nuts (rear suspension member side), and remove rear lower link mounting bolts and nuts (axle housing side).
4. Slowly lower jack, then remove upper seat, coil spring and rubber sheet from rear lower link.
5. Remove rear lower link mounting nuts and adjusting bolts (rear suspension member side), and remove rear lower link.

INSTALLATION

Note the following, and install in the reverse order of removal.

- Match up rubber seat indentions and rear lower link grooves and attach.
- Install coil spring by aligning the lower end of the large diameter side to the step (A) between the rubber seat (1) and the rear lower link (2).

CAUTION:

Make sure spring is not up side down.

- Perform the final tightening of rear suspension member and axle installation position (rubber bushing) under unladen condition with tires on level ground.

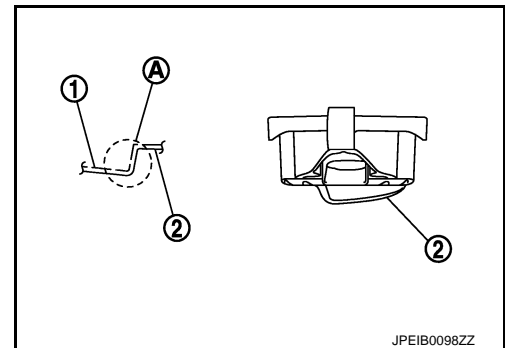

REAR LOWER LINK & COIL SPRING

< REMOVAL AND INSTALLATION >

Inspection

INFOID:000000004347322

INSPECTION AFTER REMOVAL

Check rear lower link, bushing and coil spring for deformation, crack, and damage. Replace it if necessary.

INSPECTION AFTER INSTALLATION

1. Check wheel alignment. Refer to [RSU-6, "Inspection"](#).
2. Adjust neutral position of steering angle sensor. Refer to [BRC-9, "ADJUSTMENT OF STEERING ANGLE SENSOR NEUTRAL POSITION : Special Repair Requirement"](#).

A

B

C

D

RSU

F

G

H

I

J

K

L

M

N

O

P

REAR SHOCK ABSORBER

< REMOVAL AND INSTALLATION >

REAR SHOCK ABSORBER

Exploded View

INFOID:000000004347323

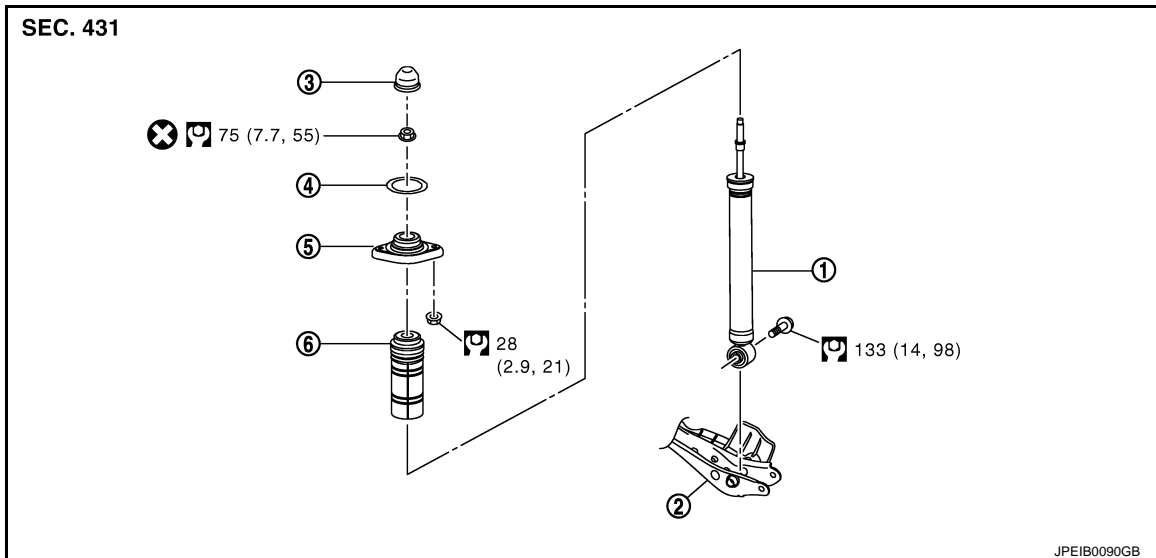

- | | | |
|-------------------|------------------------------------|-----------------------|
| 1. Shock absorber | 2. Front lower link | 3. Cap |
| 4. Mounting seal | 5. Shock absorber mounting bracket | 6. Bound bumper cover |

Refer to [GI-4, "Components"](#) for symbols in the figure.

Removal and Installation

INFOID:000000004347324

REMOVAL

1. Remove tires with power tool.
2. Set suitable jack under axle assembly to relieve the coil spring tension.
3. Remove shock absorber. (Lower side).
4. Gradually lower the jack to remove it from rear lower link.
5. Remove shock absorber assembly mounting nuts (upper side) (←), and then remove shock absorber assembly.

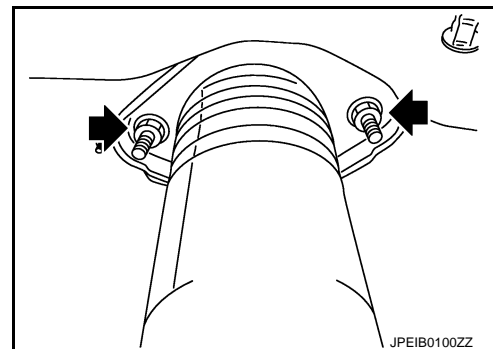

INSTALLATION

Note the following, and install in the reverse order of removal.

- Perform final tightening of bolts and nuts at the shock absorber lower side (rubber bushing), under unladen conditions with tires on level ground.

Disassembly and Assembly

INFOID:000000004347325

DISASSEMBLY

CAUTION:

Never damage shock absorber piston rod when removing components from shock absorber.

1. Remove cap from mounting bracket.

REAR SHOCK ABSORBER

< REMOVAL AND INSTALLATION >

2. Remove mounting seal.
3. Wrap a shop cloth around lower side of shock absorber and fix it with a vise.

CAUTION:

Never set the cylindrical part of shock absorber with a vise.

4. Secure the piston rod tip so that piston rod does not turn, and remove piston rod lock nut.
5. Remove mounting seal, mounting bracket and bound bumper cover from shock absorber.

ASSEMBLY

Install in the reverse order of disassembly.

Inspection

INFOID:000000004347326

INSPECTION AFTER REMOVAL

Check the following items, and replace the parts if necessary.

- Shock absorber assembly for deformation, cracks, damage.
- Welded and sealed areas for oil leakage.

INSPECTION AFTER DISASSEMBLY

Bound Bumper and Bushing

Check bound bumper cover and bushing for cracks and damage. Replace it if necessary.

Shock Absorber

Check the following items, and replace the part if necessary.

- Shock absorber for deformation, cracks, and other damage.
- Piston rod for damage, uneven wear, and distortion.

Mounting Seal

Check mounting seal for cracks and damage. Replace it if necessary.

INSPECTION AFTER ASSEMBLY

Make sure piston rod on shock absorber is not damaged when attaching components to shock absorber.

INSPECTION AFTER INSTALLATION

1. Check wheel alignment. Refer to [RSU-6, "Inspection"](#).
2. Adjust neutral position of steering angle sensor. Refer to [BRC-9, "ADJUSTMENT OF STEERING ANGLE SENSOR NEUTRAL POSITION : Special Repair Requirement"](#).

Disposal

INFOID:000000004914851

1. Set shock absorber horizontally with the piston rod fully extended.
2. Drill 2 – 3 mm (0.08 – 0.12 in) hole at the position (●) from top as shown in the figure to release gas gradually.

NOTE:

- Drill vertically in this direction (←).
- Directly to the outer tube avoiding brackets.

A : 20 – 30 mm (0.79 – 1.18 in)

3. Position the drilled hole downward and drain oil by moving the piston rod several times.

CAUTION:

- **Wear eye protection (safety glasses).**
- **Wear gloves.**
- **Be careful with metal chips or oil blown out by the compressed gas.**
- **Dispose of drained oil according to the law and local regulations.**

NOTE:

The gas is clear, colorless, odorless, and harmless.

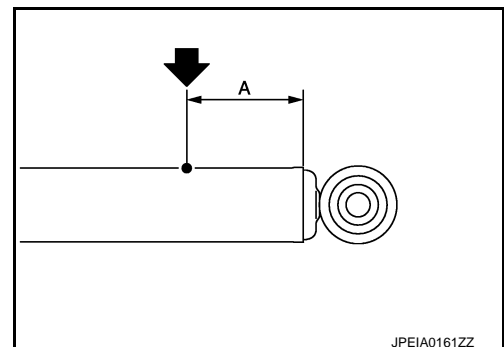

SUSPENSION ARM

< REMOVAL AND INSTALLATION >

SUSPENSION ARM

Exploded View

INFOID:000000004347327

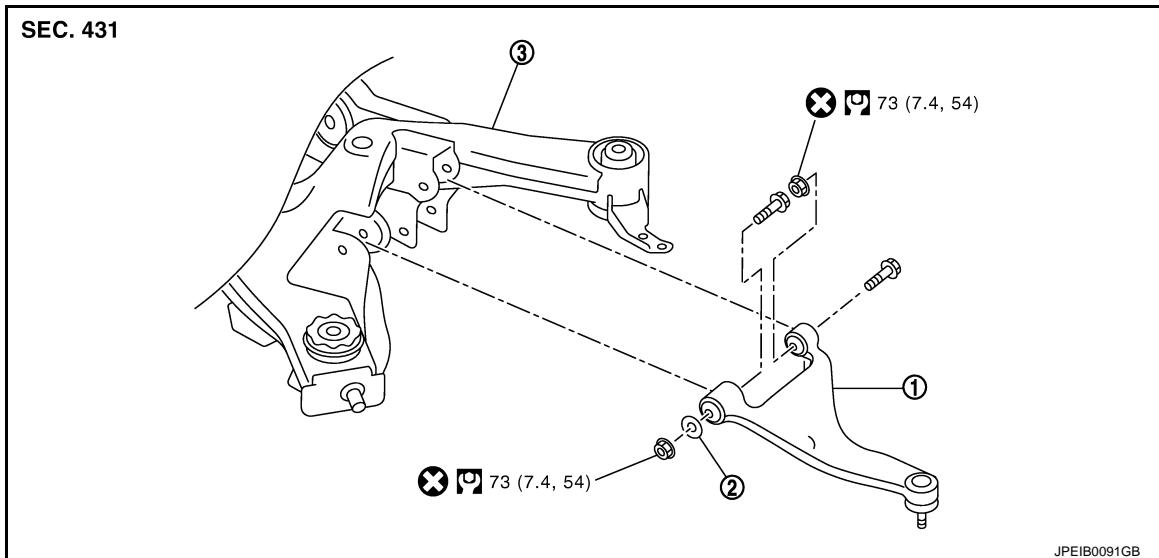

1. Suspension arm
2. Stopper rubber
3. Rear suspension member

Refer to [GI-4, "Components"](#) for symbols in the figure.

Removal and Installation

INFOID:000000004347328

REMOVAL

1. Remove tires with power tool.
2. Remove radius rod. Refer to [RSU-14, "Exploded View"](#).
3. Remove caliper assembly. Hang torque member in a place where it will not interfere with work. Refer to [BR-40, "BRAKE CALIPER ASSEMBLY : Exploded View"](#).
4. Set suitable jack under axle assembly to relieve the coil spring tension.
5. Remove stabilizer connecting rod. Refer to [RSU-16, "Exploded View"](#).
6. Remove drive shaft. Refer to [RAX-11, "Exploded View"](#).
7. Remove height sensor (with xenon head lamp). Refer to [EXL-202, "Exploded View"](#).
8. Remove cotter pin of suspension arm ball joint, and loosen nut. Refer to [RAX-8, "Exploded View"](#).
9. Remove suspension arm mounting bolts and nuts (rear suspension member side).
10. Use the ball joint remover to remove suspension arm from axle housing. Be careful not to damage ball joint boot.
CAUTION:
Tighten temporarily mounting nut to prevent damage to threads and to prevent ball joint remover from coming off.
11. Remove suspension arm.
12. Remove stabilizer connecting rod mounting bracket. Refer to [RSU-16, "Exploded View"](#).

INSTALLATION

Note the following and, install in the reverse order of removal.

- Perform final tightening of rear suspension member installation position (rubber bussing), under unladen conditions with tires on level ground.
- Never reuse cotter pin.

Inspection

INFOID:000000004347329

INSPECTION AFTER REMOVAL

SUSPENSION ARM

< REMOVAL AND INSTALLATION >

Appearance

Check the following items, and replace the part if necessary.

- Suspension arm and bushing for deformation, cracks or damage.
- Boot of ball joint for cracks or damage, and also for grease leakage.

Ball Joint Inspection

Manually move ball stud at least ten times by hand to check for smooth movement.

Swing Torque Inspection

1. Move the ball stud at least ten times by hand to check for smooth movement.
2. Hook spring balance (A) at cotter pin mounting hole. Confirm spring balance measurement value is within specifications when ball stud begins moving.

Standard

Swing torque : Refer to [RSU-19, "Ball Joint"](#).

- If swing torque exceeds the standard range, replace suspension arm assembly.

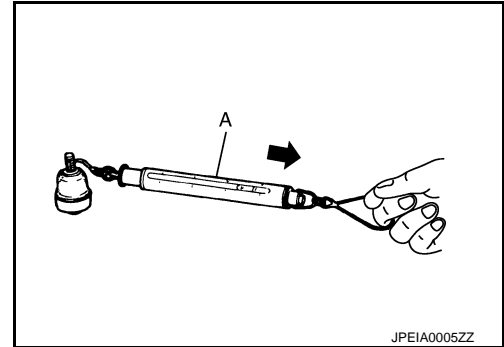

Rotating Torque Inspection

1. Move the ball stud at least ten times by hand to check for smooth movement.
2. Attach the mounting nut to ball stud. Make sure that rotating torque is within the specifications with a preload gauge (A) [SST: ST3127S000 (J-25765-A)].

Standard

Rotating torque : Refer to [RSU-19, "Ball Joint"](#).

- If rotating torque exceeds the standard range, replace suspension arm assembly.

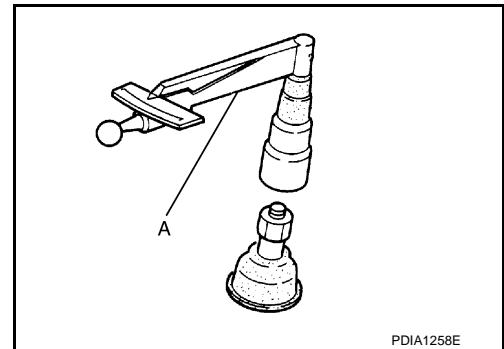

Axial End Play Inspection

1. Move the ball stud at least ten times by hand to check for smooth movement.
2. Move tip of ball stud in axial direction to check for looseness.

Standard

Axial end play : Refer to [RSU-19, "Ball Joint"](#).

- If axial end play exceeds the standard range, replace suspension arm assembly.

INSPECTION AFTER INSTALLATION

1. Check wheel alignment. Refer to [RSU-6, "Inspection"](#).
2. Adjust neutral position of height sensor (with xenon head lamp). Refer to [EXL-9, "ADDITIONAL SERVICE WHEN REPLACING CONTROL UNIT \(HEIGHT SENSOR\) : Special Repair Requirement"](#).
3. Adjust neutral position of steering angle sensor. Refer to [BRC-9, "ADJUSTMENT OF STEERING ANGLE SENSOR NEUTRAL POSITION : Special Repair Requirement"](#).

RADIUS ROD

< REMOVAL AND INSTALLATION >

RADIUS ROD

Exploded View

INFOID:000000004347330

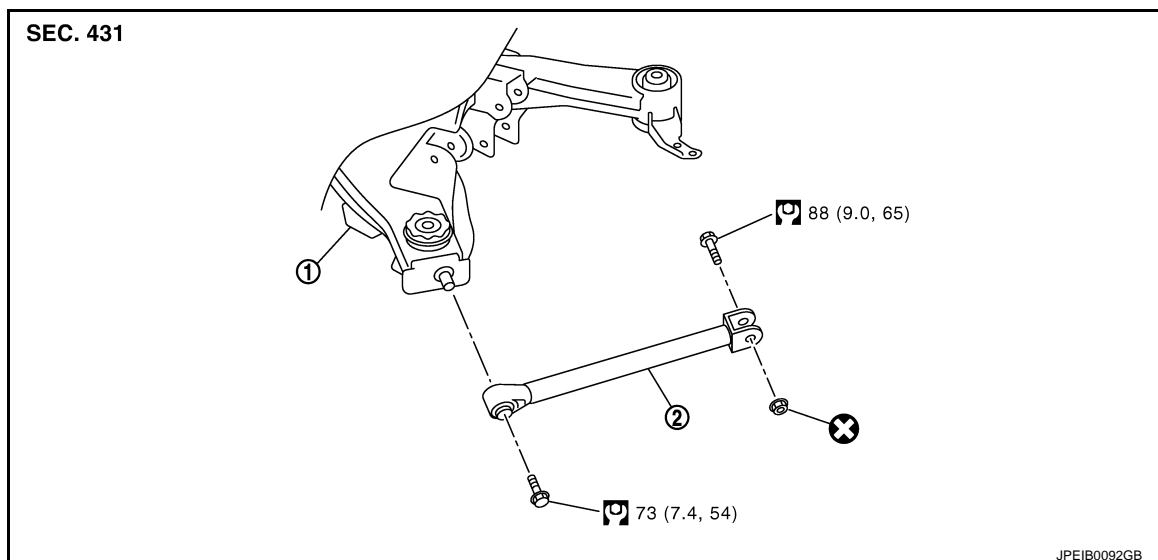

1. Rear suspension member
2. Radius rod

Refer to [GI-4. "Components"](#) for symbols in the figure.

Removal and Installation

INFOID:000000004347331

REMOVAL

1. Remove tires with power tool.
2. Remove radius rod mounting bolt and nut (axle housing side).
3. Remove radius rod mounting bolt (rear suspension member side), and remove radius rod.

INSTALLATION

Note the following, and install in the reverse order of removal.

- Perform final tightening of rear suspension member and axle installation position (rubber bushing), under unladen conditions with tires on level ground.

Inspection

INFOID:000000004347332

INSPECTION AFTER REMOVAL

Check radius rod and bushing for any deformation, cracks, or damage. Replace it if necessary.

INSPECTION AFTER INSTALLATION

1. Check wheel alignment. Refer to [RSU-6. "Inspection"](#).
2. Adjust neutral position of steering angle sensor. Refer to [BRC-9. "ADJUSTMENT OF STEERING ANGLE SENSOR NEUTRAL POSITION : Special Repair Requirement"](#).

FRONT LOWER LINK

< REMOVAL AND INSTALLATION >

FRONT LOWER LINK

Exploded View

INFOID:000000004347333

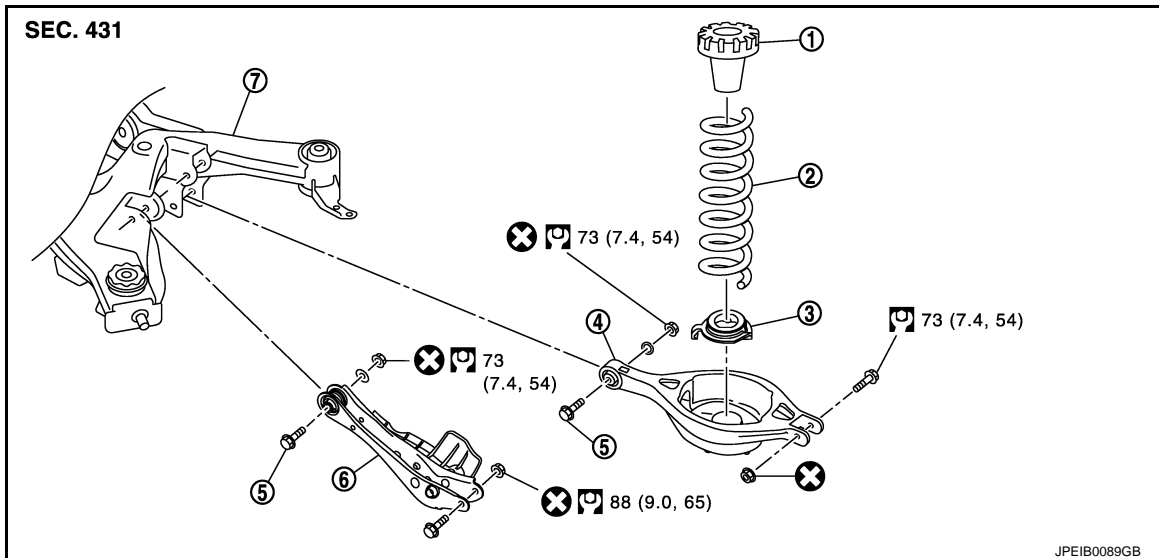

- | | | |
|---------------------------|-------------------|---------------------|
| 1. Upper seat | 2. Coil spring | 3. Rubber seat |
| 4. Rear lower link | 5. Adjusting bolt | 6. Front lower link |
| 7. Rear suspension member | | |

Refer to [GI-4, "Components"](#) for symbols in the figure.

Removal and Installation

INFOID:000000004347334

REMOVAL

1. Remove tires with power tool.
2. Set suitable jack under axle assembly to relieve the coil spring tension.
3. Remove shock absorber mounting bolts (lower side). Refer to [RSU-10, "Exploded View"](#).
4. Remove front lower link mounting bolts and nuts (rear suspension member side).
5. Remove front lower link mounting bolts and nuts (axle housing side), and remove front lower link.

INSTALLATION

Note the following, and install in the reverse order of removal.

- Perform final tightening of rear suspension member and axle installation position (rubber bushing), under unladen conditions with tires on level ground.

Inspection

INFOID:000000004347335

INSPECTION AFTER REMOVAL

Check front lower link and bushing for any deformation, cracks, or damage. Replace it if necessary.

INSPECTION AFTER INSTALLATION

1. Check wheel alignment. Refer to [RSU-6, "Inspection"](#).
2. Adjust neutral position of steering angle sensor. Refer to [BRC-9, "ADJUSTMENT OF STEERING ANGLE SENSOR NEUTRAL POSITION : Special Repair Requirement"](#).

REAR STABILIZER

< REMOVAL AND INSTALLATION >

REAR STABILIZER

Exploded View

INFOID:000000004347336

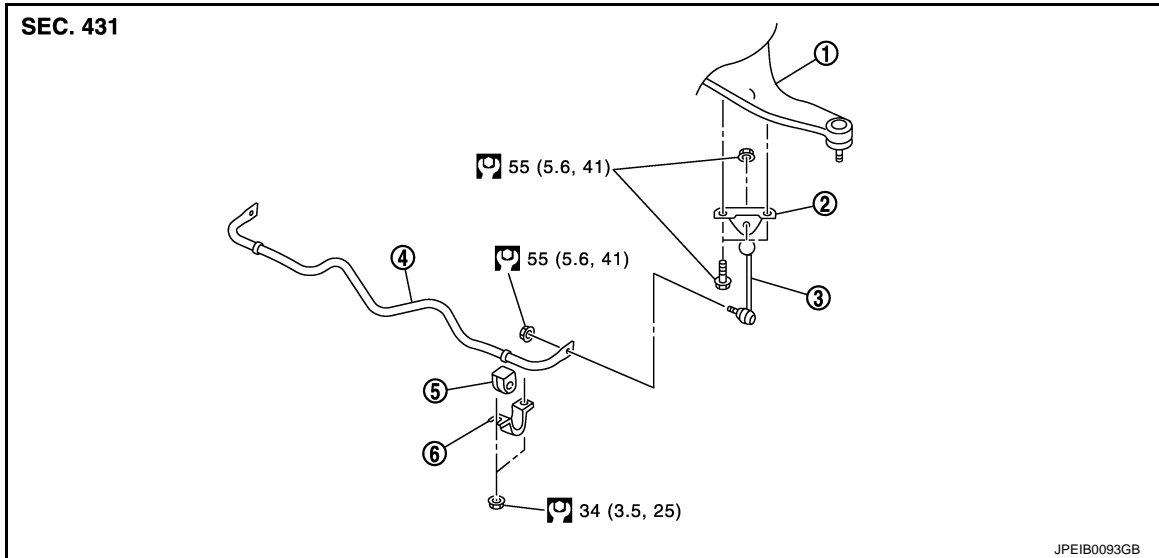

- | | | |
|-------------------|---|------------------------------|
| 1. Suspension arm | 2. Stabilizer connecting rod mounting bracket | 3. Stabilizer connecting rod |
| 4. Stabilizer bar | 5. Stabilizer bushing | 6. Stabilizer clamp |

Refer to [GI-4, "Components"](#) for symbols in the figure.

Removal and Installation

INFOID:000000004347337

REMOVAL

1. Remove center muffler. Refer to [EX-5, "Exploded View"](#).
2. Remove under cover.
3. Remove stabilizer connecting rod mounting nuts (lower side), and remove stabilizer connecting rods from stabilizer bar.
4. Remove stabilizer connecting rod mounting nuts (upper side), and remove stabilizer connecting rods from stabilizer connecting rod mounting brackets.
5. Remove mounting nuts on stabilizer clamps and remove stabilizer bar.
6. Remove stabilizer connecting rod mounting brackets.

INSTALLATION

Note the following, and install in the reverse order of removal.

- Tighten the mounting nut to the specified torque while holding a hexagonal part of stabilizer connecting rod side.

Inspection

INFOID:000000004347338

INSPECTION AFTER REMOVAL

Check stabilizer bar, stabilizer connecting rod, stabilizer bushing and stabilizer clamp for deformation, cracks or damage. Replace it if necessary.

REAR SUSPENSION MEMBER

< UNIT REMOVAL AND INSTALLATION >

UNIT REMOVAL AND INSTALLATION

REAR SUSPENSION MEMBER

Exploded View

INFOID:000000004347339

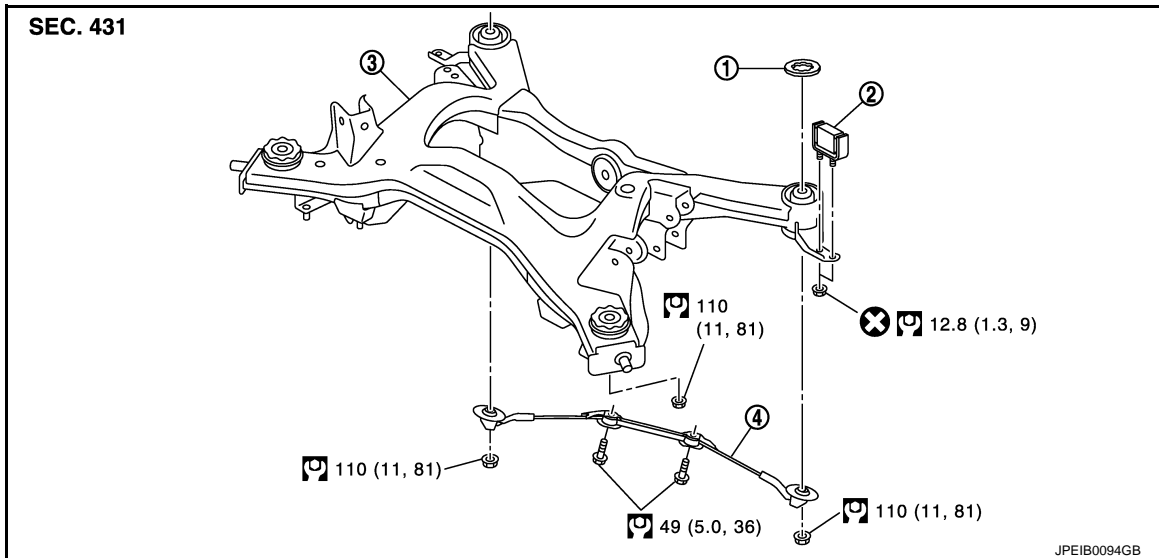

1. Mount stopper
2. Dynamic damper
3. Rear suspension member
4. Pin stay

Refer to [GI-4, "Components"](#) for symbols in the figure.

Removal and Installation

INFOID:000000004347340

REMOVAL

1. Remove tires with power tool.
2. Remove radius rod. Refer to [RSU-14, "Exploded View"](#).
3. Remove caliper assemblies. Hang caliper assembly in a place where it will not interfere with work. Refer to [BR-40, "BRAKE CALIPER ASSEMBLY : Exploded View"](#).
CAUTION:
Avoid depressing brake pedal while brake caliper is removed.
4. Remove disc rotors. Refer to [BR-41, "BRAKE CALIPER ASSEMBLY : Removal and Installation"](#).
5. Remove wheel sensors and sensor harness from rear suspension member and suspension arms. Refer to [BRC-109, "REAR WHEEL SENSOR : Exploded View"](#).
6. Remove height sensor harness from rear suspension member (with xenon head lamp). Refer to [EXL-202, "Exploded View"](#).
7. Remove center muffler. Refer to [EX-5, "Exploded View"](#).
8. Remove stabilizer bar. Refer to [RSU-16, "Exploded View"](#).
9. Remove drive shafts. Refer to [RAX-11, "Exploded View"](#).
10. Remove propeller shaft. Refer to [DLN-82, "Exploded View"](#) (2WD), [DLN-91, "Exploded View"](#) (AWD).
11. Remove final drive. Refer to [DLN-161, "2WD : Exploded View"](#) (2WD), [DLN-162, "AWD : Exploded View"](#) (AWD).
12. Remove parking brake cable mounting bolts and separate parking brake cable from vehicle and rear suspension member. Refer to [PB-7, "Exploded View"](#).
13. Remove shock absorber mounting bolts (lower side). Refer to [RSU-10, "Exploded View"](#).
14. Remove rear lower links and coil springs. Refer to [RSU-8, "Exploded View"](#).
15. Remove under cover.
16. Set suitable jack under rear suspension member.

REAR SUSPENSION MEMBER

< UNIT REMOVAL AND INSTALLATION >

17. Remove pin stay.
18. Remove rear suspension member mounting nuts.
19. Slowly lower jack, then remove rear suspension member, suspension arms, front lower links, wheel hub and housings from vehicle as a unit.
20. Remove mounting bolts and nuts, then remove suspension arms, front lower links, wheel hub and housings from rear suspension member. Refer to [RSU-12, "Exploded View"](#), [RSU-15, "Exploded View"](#), [RAX-8, "Exploded View"](#)

INSTALLATION

Note the following, and install in the reverse order of the removal.

- Perform the final tightening of each of parts under unladen conditions, which were removed when removing rear suspension assembly.
- Check wheel sensor harness for proper connection. Refer to [BRC-109, "REAR WHEEL SENSOR : Exploded View"](#).
- Never reuse cotter pin.

Inspection

INFOID:000000004347341

INSPECTION AFTER REMOVAL

Check rear suspension member for deformation, cracks, or any other damage. Replace if necessary.

INSPECTION AFTER INSTALLATION

1. Adjust parking brake operation (stroke). Refer to [PB-3, "Inspection and Adjustment"](#).
2. Check wheel alignment. Refer to [RSU-6, "Inspection"](#).
3. Adjust neutral position of height sensor (with xenon head lamp). Refer to [EXL-9, "ADDITIONAL SERVICE WHEN REPLACING CONTROL UNIT \(HEIGHT SENSOR\) : Special Repair Requirement"](#).
4. Adjust neutral position of steering angle sensor. Refer to [BRC-9, "ADJUSTMENT OF STEERING ANGLE SENSOR NEUTRAL POSITION : Special Repair Requirement"](#).

SERVICE DATA AND SPECIFICATIONS (SDS)

< SERVICE DATA AND SPECIFICATIONS (SDS)

SERVICE DATA AND SPECIFICATIONS (SDS)

SERVICE DATA AND SPECIFICATIONS (SDS)

Wheel Alignment

INFOID:0000000004347342

Item		Standard	
Camber Degree minute (Decimal degree)	Minimum	-1° 05' (-1.08°)	
	Nominal	-0° 35' (-0.58°)	
	Maximum	-0° 05' (-0.09°)	
Toe-in	Total toe-in Distance	Minimum	0 mm (0 in)
		Nominal	In 2.9 mm (0.114 in)
		Maximum	In 5.8 mm (0.228 in)
	Toe angle (left wheel or right wheel) Degree minute (Decimal degree)	Minimum	0° 00' (0.00°)
		Nominal	In 0° 07' (0.12°)
		Maximum	In 0° 14' (0.23°)

Measure value under unladen* conditions.

*: Fuel, engine coolant and lubricant are full. Spare tire, jack, hand tools and mats are in designated positions.

Ball Joint

INFOID:0000000004347343

Item	Standard
Swing torque	0.5 – 3.4 N·m (0.06 – 0.34 kg-m, 5 – 30 in-lb)
Measurement on spring balance (cotter pinhole position)	8.1 – 54.8 N (0.83 – 5.59 kg, 1.83 – 12.31 lb)
Rotating torque	0.5 – 3.4 N·m (0.06 – 0.34 kg-m, 5 – 30 in-lb)
Axial end play	0 mm (0 in)

Wheelarch Height

INFOID:0000000004347344

Item	Standard			
	2WD		AWD	
Axle type				
Tire size	225/60R17	225/55R18	225/60R17	225/55R18
Front (Hf)	745 mm (29.33 in)	750 mm (29.53 in)	742 mm (29.21 in)	747 mm (29.41 in)
Rear (Hr)	757 mm (29.80 in)	762 mm (30.00 in)	757 mm (29.80 in)	762 mm (30.00 in)

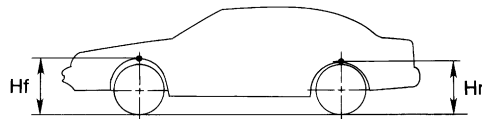

SFA818A

Measure value under unladen* conditions.

*: Fuel, engine coolant and lubricant are full. Spare tire, jack, hand tools and mats are in designated positions.