

A
B
C

TM

SECTION

TRANSAXLE & TRANSMISSION

TM

CONTENTS

5AT: RE5R05A		
BASIC INSPECTION	Description	46
DIAGNOSIS AND REPAIR WORK FLOW	DTC Logic	46
Work Flow	Diagnosis Procedure	46
Diagnostic Work Sheet	P0700 TRANSMISSION CONTROL	48
SYSTEM DESCRIPTION	Description	48
A/T CONTROL SYSTEM	DTC Logic	48
System Diagram	Diagnosis Procedure	48
System Description	P0705 TRANSMISSION RANGE SWITCH A ...	49
Component Parts Location	Description	49
Component Description	DTC Logic	49
SHIFT MECHANISM	Diagnosis Procedure	49
Cross-Sectional View	P0717 INPUT SPEED SENSOR A	51
System Diagram	Description	51
System Description	DTC Logic	51
Component Parts Location	Diagnosis Procedure	51
Component Description	P0720 OUTPUT SPEED SENSOR	52
SHIFT LOCK SYSTEM	Description	52
System Description	DTC Logic	52
Component Parts Location	Diagnosis Procedure	53
Component Description	P0725 ENGINE SPEED	55
ON BOARD DIAGNOSTIC (OBD) SYSTEM	Description	55
Diagnosis Description	DTC Logic	55
DIAGNOSIS SYSTEM (TCM)	Diagnosis Procedure	55
Diagnosis Description	P0731 1GR INCORRECT RATIO	57
CONSULT-III Function (TRANSMISSION)	Description	57
DTC/CIRCUIT DIAGNOSIS	DTC Logic	57
U1000 CAN COMM CIRCUIT	Diagnosis Procedure	58
Description	P0732 2GR INCORRECT RATIO	59
DTC Logic	Description	59
Diagnosis Procedure	DTC Logic	59
P0615 STARTER RELAY	Diagnosis Procedure	60
	P0733 3GR INCORRECT RATIO	61
	Description	61
	DTC Logic	61

E

F

G

H

I

J

K

L

M

N

O

P

Diagnosis Procedure	62	Diagnosis Procedure	77
P0734 4GR INCORRECT RATIO	63	P1757 FRONT BRAKE SOLENOID	78
Description	63	Description	78
DTC Logic	63	DTC Logic	78
Diagnosis Procedure	64	Diagnosis Procedure	78
P0735 5GR INCORRECT RATIO	65	P1762 DIRECT CLUTCH SOLENOID	79
Description	65	Description	79
DTC Logic	65	DTC Logic	79
Diagnosis Procedure	66	Diagnosis Procedure	79
P0740 TORQUE CONVERTER	67	P1767 HIGH AND LOW REVERSE CLUTCH	
Description	67	SOLENOID	80
DTC Logic	67	Description	80
Diagnosis Procedure	67	DTC Logic	80
P0744 TORQUE CONVERTER	68	Diagnosis Procedure	80
Description	68	P1772 LOW COAST BRAKE SOLENOID	81
DTC Logic	68	Description	81
Diagnosis Procedure	68	DTC Logic	81
P0745 PRESSURE CONTROL SOLENOID A... 69		Diagnosis Procedure	81
Description	69	P1774 LOW COAST BRAKE SOLENOID	82
DTC Logic	69	Description	82
Diagnosis Procedure	69	DTC Logic	82
P1705 TP SENSOR	70	Diagnosis Procedure	82
Description	70	P1815 M-MODE SWITCH	84
DTC Logic	70	Description	84
Diagnosis Procedure	70	DTC Logic	84
P1710 TRANSMISSION FLUID TEMPERA-		Diagnosis Procedure	84
TURE SENSOR	71	Component Inspection (Manual Mode Switch)	86
Description	71	MAIN POWER SUPPLY AND GROUND CIR-	
DTC Logic	71	CUIT	88
Diagnosis Procedure	71	Description	88
Component Inspection (A/T fluid temperature sen-		Diagnosis Procedure	88
sor 1)	73	SHIFT POSITION INDICATOR CIRCUIT	90
Component Inspection (A/T fluid temperature sen-		Description	90
sor 2)	73	Component Function Check	90
P1721 VEHICLE SPEED SIGNAL	74	Diagnosis Procedure	90
Description	74	SHIFT LOCK SYSTEM	91
DTC Logic	74	Description	91
Diagnosis Procedure	74	Wiring Diagram - A/T SHIFT LOCK SYSTEM -	91
P1730 INTERLOCK	75	Component Function Check	92
Description	75	Diagnosis Procedure	93
DTC Logic	75	Component Inspection (Shift lock solenoid)	94
Judgment of Interlock	75	Component Inspection (Stop lamp switch)	94
Diagnosis Procedure	75	SELECTOR LEVER POSITION INDICATOR ... 96	
P1731 1ST ENGINE BRAKING	76	Description	96
Description	76	Component Function Check	96
DTC Logic	76	Diagnosis Procedure	96
Diagnosis Procedure	76	Component Inspection	99
P1752 INPUT CLUTCH SOLENOID	77	ECU DIAGNOSIS INFORMATION	101
Description	77	TCM	101
DTC Logic	77		

Reference Value	101	2WD	157	
Wiring Diagram - A/T CONTROL SYSTEM -	104	2WD : Exploded View	157	A
Fail-Safe	108	2WD : Removal and Installation	158	
DTC Inspection Priority Chart	110	2WD : Inspection	159	
DTC Index	110	AWD	159	B
SYMPTOM DIAGNOSIS	112	AWD : Exploded View	160	
SYSTEM SYMPTOM	112	AWD : Removal and Installation	161	C
Symptom Table	112	AWD : Inspection	162	
PRECAUTION	137	CONTROL ROD	163	TM
PRECAUTIONS	137	Exploded View	163	
Precaution for Supplemental Restraint System (SRS) "AIR BAG" and "SEAT BELT PRE-TEN- SIONER"	137	Removal and Installation	163	
On Board Diagnosis (OBD) System of A/T and En- gine	137	Inspection and Adjustment	163	
General Precautions	138	CONTROL VALVE WITH TCM	165	E
Service Notice or Precaution	138	Exploded View	165	
PREPARATION	140	Removal and Installation	165	F
PREPARATION	140	Inspection	170	
Special Service Tool	140	A/T FLUID TEMPERATURE SENSOR 2	171	G
Commercial Service Tool	141	Exploded View	171	
PERIODIC MAINTENANCE	142	Removal and Installation	171	
A/T FLUID	142	Inspection	173	H
Changing	142	PARKING COMPONENTS	174	
Adjustment	143	2WD	174	I
A/T FLUID COOLER	145	2WD : Exploded View	174	
Cleaning	145	2WD : Removal and Installation	174	
Inspection	147	2WD : Inspection	178	J
STALL TEST	148	REAR OIL SEAL	180	
Inspection and Judgment	148	2WD	180	K
LINE PRESSURE TEST	149	2WD : Exploded View	180	
Inspection and Judgment	149	2WD : Removal and Installation	180	
ROAD TEST	151	2WD : Inspection and Adjustment	181	L
Description	151	AWD	181	
Check Before Engine Is Started	151	AWD : Exploded View	181	
Check at Idle	151	AWD : Removal and Installation	181	
Cruise Test - Part 1	152	AWD : Inspection and Adjustment	182	M
Cruise Test - Part 2	153	OUTPUT SPEED SENSOR	183	
Cruise Test - Part 3	153	2WD	183	N
A/T POSITION	155	2WD : Exploded View	183	
2WD	155	2WD : Removal and Installation	183	
2WD : Inspection and Adjustment	155	2WD : Inspection and Adjustment	187	O
AWD	155	AIR BREATHING HOSE	188	
AWD : Inspection and Adjustment	155	2WD	188	P
REMOVAL AND INSTALLATION	157	2WD : Exploded View	188	
A/T SHIFT SELECTOR	157	2WD : Removal and Installation	188	
		AWD	189	
		AWD : Exploded View	189	
		AWD : Removal and Installation	189	
		A/T FLUID COOLER TUBE	191	

2WD	191	FRONT CARRIER, INPUT CLUTCH, REAR	
2WD : Exploded View	191	INTERNAL GEAR	258
2WD : Removal and Installation	191	Exploded View	258
2WD : Inspection and Adjustment	192	Disassembly	259
AWD	192	Assembly	260
AWD : Exploded View	193	Inspection	262
AWD : Removal and Installation	193	MID SUN GEAR, REAR SUN GEAR, HIGH	
AWD : Inspection and Adjustment	194	AND LOW REVERSE CLUTCH HUB	263
UNIT REMOVAL AND INSTALLATION ...	195	Exploded View	263
TRANSMISSION ASSEMBLY	195	Disassembly	263
2WD	195	Assembly	265
2WD : Exploded View	195	Inspection	267
2WD : Removal and Installation	195	HIGH AND LOW REVERSE CLUTCH	268
2WD : Inspection and Adjustment	197	Exploded View	268
AWD	197	Disassembly	268
AWD : Exploded View	198	Assembly	268
AWD : Removal and Installation	198	Inspection	269
AWD : Inspection and Adjustment	200	DIRECT CLUTCH	270
UNIT DISASSEMBLY AND ASSEMBLY ..	201	Exploded View	270
TRANSMISSION ASSEMBLY	201	Disassembly	270
Exploded View	201	Assembly	270
Oil Channel	208	Inspection	271
Location of Adjusting Shims, Needle Bearings,		SERVICE DATA AND SPECIFICATIONS	
Thrust Washers and Snap Rings	210	(SDS)	272
Disassembly	211	SERVICE DATA AND SPECIFICATIONS	
Assembly	229	(SDS)	272
Inspection	252	General Specification	272
OIL PUMP	253	Vehicle Speed at Which Gear Shifting Occurs ...	272
Exploded View	253	Vehicle Speed at Which Lock-up Occurs/Releas-	
Disassembly	253	es	272
Assembly	254	Stall Speed	272
FRONT SUN GEAR, 3RD ONE-WAY		Line Pressure	273
CLUTCH	256	Input Speed Sensor	273
Exploded View	256	Output Speed Sensor	273
Disassembly	256	Reverse Brake	273
Assembly	257	Total End Play	273
Inspection	257	Torque Converter	273

BASIC INSPECTION

DIAGNOSIS AND REPAIR WORK FLOW

Work Flow

INFOID:000000004342863

INTRODUCTION

The TCM receives a signal from the output speed sensor, accelerator pedal position sensor (throttle position sensor) or transmission range switch. Then provides shift control or lock-up control via A/T solenoid valves.

The TCM also communicates with the ECM by means of a signal transmitted from sensing elements used with the OBD-related parts of the A/T system for malfunction-diagnostic purposes. The TCM is capable of diagnosing malfunctioning parts while the ECM can store malfunctions in its memory.

Input and output signals must always be correct and stable in the operation of the A/T system. The A/T system must be in good operating condition and be free of valve seizure, solenoid valve malfunction, etc.

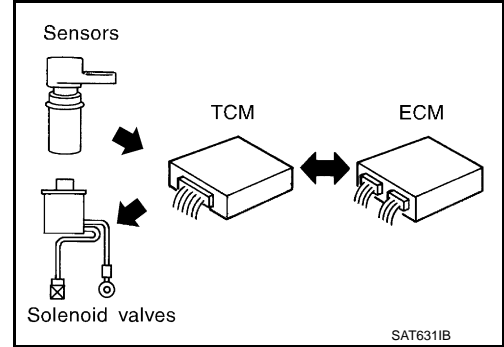

It is much more difficult to diagnose an error that occurs intermittently rather than continuously. Most intermittent errors are caused by poor electric connections or improper wiring. In this case, careful checking of suspected circuits may help prevent the replacement of good parts.

A visual check may not find the cause of the errors. A road test with CONSULT-III (or GST) or a circuit tester connected should be performed. Follow the "DETAILED FLOW".

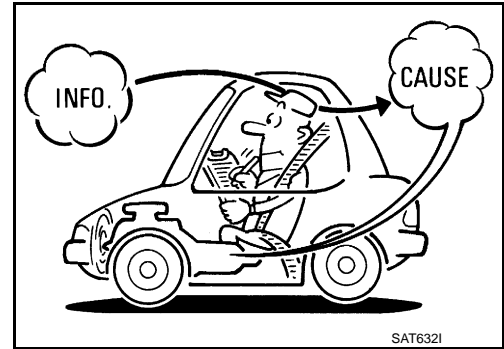

Before undertaking actual checks, take a few minutes to talk with the customer who has the driveability complaint. The customer can supply good information about such errors, especially intermittent ones. Find out what symptoms are present and under what conditions they occur. A "Diagnostic work sheet" as shown in the example (Refer to [TM-6](#)) should be used.

Start your diagnosis by looking for "conventional" errors first. This will help troubleshoot driveability errors on an electronically controlled engine vehicle.

Also check related Service bulletins.

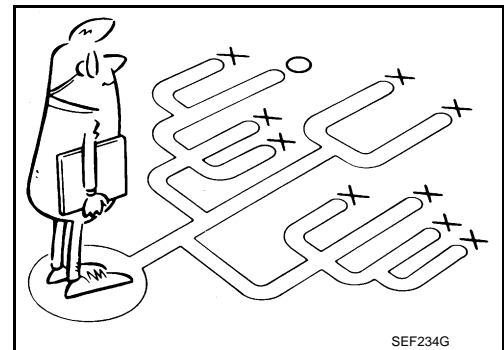

DETAILED FLOW

1. COLLECT THE INFORMATION FROM THE CUSTOMER

Get the detailed information from the customer about the symptom (the condition and the environment when the incident/malfunction occurred) using diagnosis worksheet. Refer to [TM-6, "Diagnostic Work Sheet"](#).

>> GO TO 2.

2. CHECK SYMPTOM 1

Check the following items based on the information obtained from the customer.

- Fail-safe. Refer to [TM-108, "Fail-Safe"](#).
- A/T fluid leakage.
- Stall test. Refer to [TM-148, "Inspection and Judgment"](#).
- Line pressure test. Refer to [TM-149, "Inspection and Judgment"](#).

DIAGNOSIS AND REPAIR WORK FLOW

< BASIC INSPECTION >

[5AT: RE5R05A]

>> GO TO 3.

3. CHECK DTC

1. Check DTC.
2. Perform the following procedure if DTC is detected.
 - Record DTC.
 - Erase DTC. Refer to [TM-36. "Diagnosis Description"](#).

Is any DTC detected?

YES >> GO TO 4.

NO >> GO TO 6.

4. PERFORM DIAGNOSTIC PROCEDURE

Perform "Diagnosis Procedure" for the displayed DTC.

>> GO TO 5.

5. PERFORM DTC CONFIRMATION PROCEDURE

Perform "DTC CONFIRMATION PROCEDURE" for the displayed DTC.

Is any DTC detected?

YES >> GO TO 4.

NO >> GO TO 6.

6. CHECK SYMPTOM 2

Try to confirm the symptom described by the customer.

Is any malfunction present?

YES >> GO TO 7.

NO >> INSPECTION END

7. ROAD TEST

Perform "ROAD TEST". Refer to [TM-151. "Description"](#).

>> GO TO 8.

8. CHECK SYMPTOM 3

Try to confirm the symptom described by the customer.

Is any malfunction present?

YES >> GO TO 2.

NO >> INSPECTION END

Diagnostic Work Sheet

INFOID:000000004342864

INFORMATION FROM CUSTOMER

KEY POINTS

- **WHAT**..... Vehicle and A/T model
- **WHEN**..... Date, Frequencies
- **WHERE**..... Road conditions
- **HOW**..... Operating conditions, Symptoms

Customer name MR/MS	Model and Year	VIN
Trans. Model	Engine	Mileage
Malfunction Date	Manuf. Date	In Service Date
Frequency	<input type="checkbox"/> Continuous <input type="checkbox"/> Intermittent (times a day)	

DIAGNOSIS AND REPAIR WORK FLOW

< BASIC INSPECTION >

[5AT: RE5R05A]

Symptoms	<input type="checkbox"/> Vehicle does not move. (<input type="checkbox"/> Any position <input type="checkbox"/> Particular position)	
	<input type="checkbox"/> No up-shift (<input type="checkbox"/> 1st → 2nd <input type="checkbox"/> 2nd → 3rd <input type="checkbox"/> 3rd → 4th <input type="checkbox"/> 4th → 5th)	
	<input type="checkbox"/> No down-shift (<input type="checkbox"/> 5th → 4th <input type="checkbox"/> 4th → 3rd <input type="checkbox"/> 3rd → 2nd <input type="checkbox"/> 2nd → 1st)	
	<input type="checkbox"/> Lock-up malfunction	
	<input type="checkbox"/> Shift point too high or too low.	
	<input type="checkbox"/> Shift shock or slip (<input type="checkbox"/> N → D <input type="checkbox"/> N → R <input type="checkbox"/> Lock-up <input type="checkbox"/> Any drive position)	
	<input type="checkbox"/> Noise or vibration	
	<input type="checkbox"/> No kick down	
	<input type="checkbox"/> No pattern select	
<input type="checkbox"/> Others ()		
A/T CHECK indicator lamp	<input type="checkbox"/> Continuously lit	<input type="checkbox"/> Not lit
Malfunction indicator lamp (MIL)	<input type="checkbox"/> Continuously lit	<input type="checkbox"/> Not lit

DIAGNOSTIC WORK SHEET

1	<input type="checkbox"/> Read the item on cautions concerning fail-safe and understand the customer's complaint.		TM-108	
2	<input type="checkbox"/> A/T fluid inspection, stall test and line pressure test		TM-148	
		<input type="checkbox"/> A/T fluid leakage		
		<input type="checkbox"/> Stall test		
		<table border="1" style="width: 100%; border-collapse: collapse;"> <tr> <td style="width: 50%; vertical-align: top;"> <input type="checkbox"/> Torque converter one-way clutch <input type="checkbox"/> Front brake <input type="checkbox"/> High and low reverse clutch <input type="checkbox"/> Low coast brake <input type="checkbox"/> Forward brake <input type="checkbox"/> Reverse brake <input type="checkbox"/> Forward one-way clutch </td> <td style="width: 50%; vertical-align: top;"> <input type="checkbox"/> 1st one-way clutch <input type="checkbox"/> 3rd one-way clutch <input type="checkbox"/> Engine <input type="checkbox"/> Line pressure low <input type="checkbox"/> Except for input clutch and direct clutch, clutches and brakes OK </td> </tr> </table>		<input type="checkbox"/> Torque converter one-way clutch <input type="checkbox"/> Front brake <input type="checkbox"/> High and low reverse clutch <input type="checkbox"/> Low coast brake <input type="checkbox"/> Forward brake <input type="checkbox"/> Reverse brake <input type="checkbox"/> Forward one-way clutch
<input type="checkbox"/> Torque converter one-way clutch <input type="checkbox"/> Front brake <input type="checkbox"/> High and low reverse clutch <input type="checkbox"/> Low coast brake <input type="checkbox"/> Forward brake <input type="checkbox"/> Reverse brake <input type="checkbox"/> Forward one-way clutch	<input type="checkbox"/> 1st one-way clutch <input type="checkbox"/> 3rd one-way clutch <input type="checkbox"/> Engine <input type="checkbox"/> Line pressure low <input type="checkbox"/> Except for input clutch and direct clutch, clutches and brakes OK			
<input type="checkbox"/> Line pressure test - Suspected part:		TM-149		
3	<input type="checkbox"/> Perform self-diagnosis. — Check detected items to repair or replace malfunctioning part.		TM-40	
4	<input type="checkbox"/> Perform road test.			
	4-1	<input type="checkbox"/> Check before engine is started		
	4-2	<input type="checkbox"/> Check at idle		
	4-3	Cruise test		<input type="checkbox"/> Part 1
				<input type="checkbox"/> Part 2
				<input type="checkbox"/> Part 3
<input type="checkbox"/> Check malfunction phenomena to repair or replace malfunctioning part after completing all road tests. Refer to TM-112, "Symptom Table" .				
5	<input type="checkbox"/> Drive vehicle to check that the malfunction phenomenon has been resolved.			
6	<input type="checkbox"/> Erase the results of the self-diagnosis from the TCM and the ECM.		EC-104, TM-36	

SYSTEM DESCRIPTION

A/T CONTROL SYSTEM

System Diagram

INFOID:000000004342865

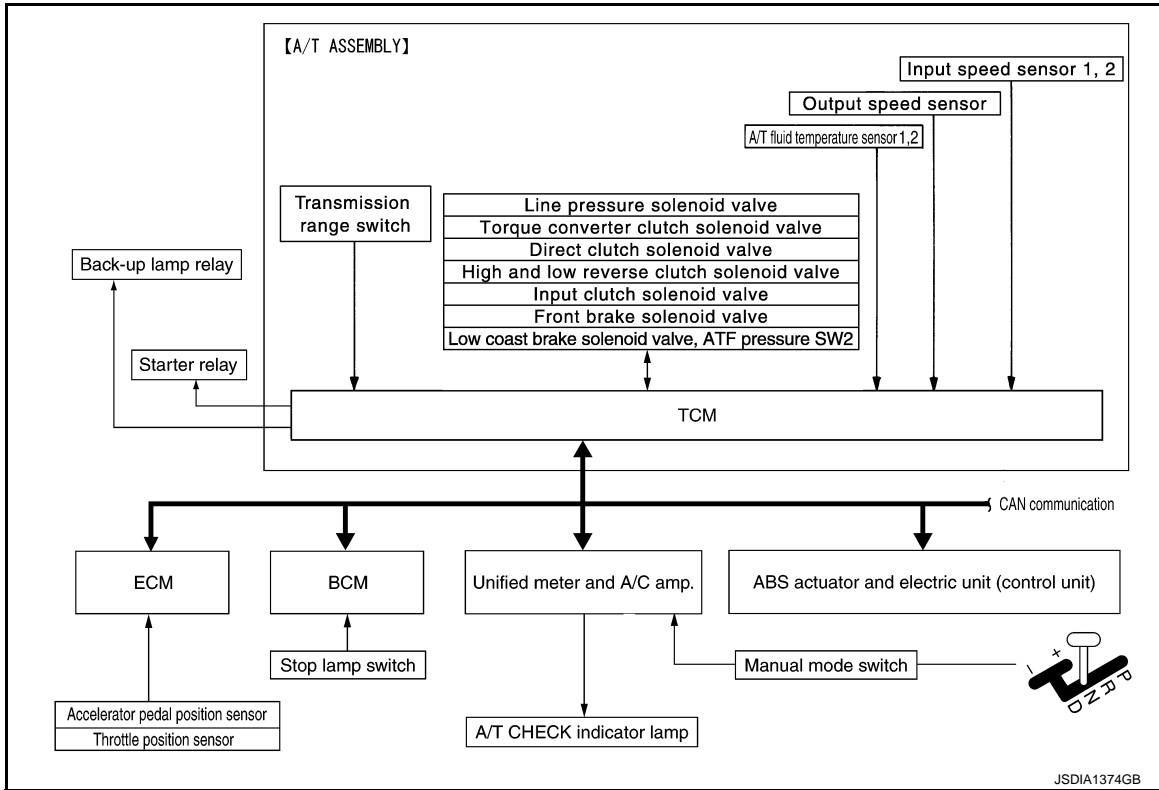

JSDIA1374GB

System Description

INFOID:000000004342866

The A/T senses vehicle operating conditions through various sensors or signals. It always controls the optimum shift position and reduces shifting and lock-up shocks.

TCM FUNCTION

The function of the TCM is to:

- Receive input signals transmitted from various switches and sensors.
- Determine required line pressure, shifting point, lock-up operation, engine brake operation, etc.
- Transmit required output signals to the respective solenoids.

SENSORS (or SIGNALS)		TCM		ACTUATORS
Transmission range switch Accelerator pedal position signal Closed throttle position signal Wide open throttle position signal Engine speed signal A/T fluid temperature sensor Output speed sensor Vehicle speed signal Manual mode switch signal Stop lamp switch signal Input speed sensor ATF pressure switch	⇒	Shift control Line pressure control Lock-up control Engine brake control Timing control Fail-safe control Self-diagnosis CONSULT-III communication line Duet-EA control CAN system	⇒	Input clutch solenoid valve Direct clutch solenoid valve Front brake solenoid valve High and low reverse clutch solenoid valve Low coast brake solenoid valve Torque converter clutch solenoid valve Line pressure solenoid valve A/T CHECK indicator lamp Back-up lamp relay Starter relay

Input/Output Signal of TCM

A/T CONTROL SYSTEM

< SYSTEM DESCRIPTION >

[5AT: RE5R05A]

Control item		Line pressure control	Vehicle speed control	Shift control	Lock-up control	Engine brake control	Fail-safe function *3	Self-diagnostics function
Input	Accelerator pedal position signal *5	X	X	X	X	X	X	X
	Output speed sensor	X	X	X	X	X	X	X
	Vehicle speed signal *1, *5						X	
	Closed throttle position signal *5		X *2	X	X		X	X *4
	Wide open throttle position signal *5						X	X *4
	Input speed sensor 1		X		X	X	X	X
	Input speed sensor 2 (for 4th speed only)		X		X	X	X	X
	Engine speed signals *5	X	X	X	X	X	X	X
	Stop lamp switch signal *5		X	X	X			X *4
	A/T fluid temperature sensors 1, 2	X	X	X	X		X	X
	ASCD or ICC sensor integrated unit	Operation signal *5		X	X	X		
Overdrive cancel signal *5			X					
Output	Direct clutch solenoid		X	X			X	X
	Input clutch solenoid		X	X			X	X
	High and low reverse clutch solenoid		X	X			X	X
	Front brake solenoid		X	X			X	X
	Low coast brake solenoid (ATF pressure switch 2)		X	X		X	X	X
	Line pressure solenoid	X	X	X	X	X	X	X
	TCC solenoid				X		X	X
	A/T CHECK indicator lamp *6							X *4
	Starter relay						X	X

*1: Spare for output speed sensor

*2: Spare for accelerator pedal position signal

*3: If these input and output signals are different, the TCM triggers the fail-safe function.

*4: Used as a condition for starting self-diagnostics; if self-diagnostics are not started, it is judged that there is some kind of error.

*5: Input by CAN communications.

*6: Output by CAN communications.

CAN COMMUNICATION

CAN (Controller Area Network) is a serial communication line for real-time application. It is an on-vehicle multiplex communication line with high data communication speed and excellent error detection ability. Many electronic control units are equipped onto a vehicle, and each control unit shares information and links with other control units during operation (not independently). In CAN communication, control units are connected with 2 communication lines (CAN-H line, CAN-L line) allowing a high rate of information transmission with less wiring. Each control unit transmits/receives data but selectively reads required data only. Refer to [LAN-26, "CAN Communication Signal Chart"](#).

LINE PRESSURE CONTROL

- When an input torque signal equivalent to the engine drive force is transmitted from the ECM to the TCM, the TCM controls the line pressure solenoid valve.

A/T CONTROL SYSTEM

< SYSTEM DESCRIPTION >

[5AT: RE5R05A]

- This line pressure solenoid controls the pressure regulator valve as the signal pressure and adjusts the pressure of the operating oil discharged from the oil pump to the line pressure most appropriate to the driving state.

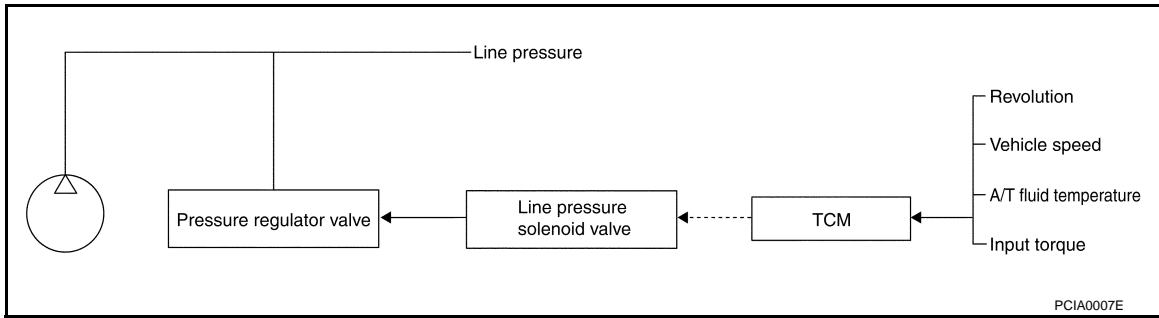

Line Pressure Control is Based On The TCM Line Pressure Characteristic Pattern

- The TCM has stored in memory a number of patterns for the optimum line pressure characteristic for the driving state.
- In order to obtain the most appropriate line pressure characteristic to meet the current driving state, the TCM controls the line pressure solenoid current value and thus controls the line pressure.

Normal Control

- Each clutch is adjusted to the necessary pressure to match the engine drive force.

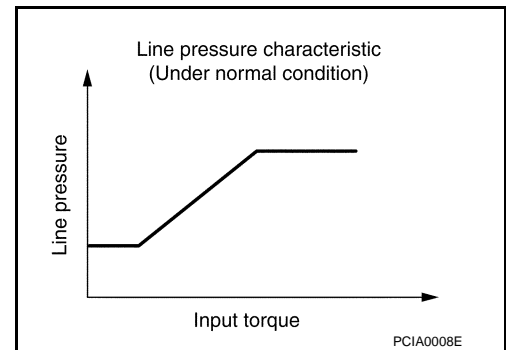

Back-up Control (Engine Brake)

- When the select operation is performed during driving and the A/T is shifted down, the line pressure is set according to the vehicle speed.

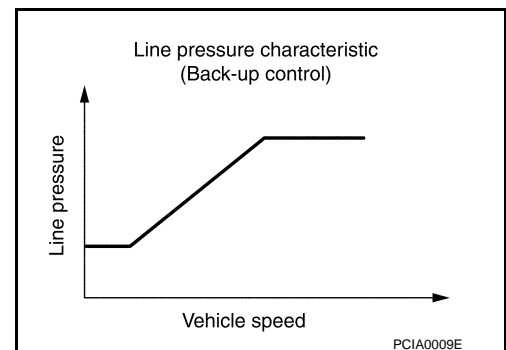

During Shift Change

A/T CONTROL SYSTEM

[5AT: RE5R05A]

< SYSTEM DESCRIPTION >

- The necessary and adequate line pressure for shift change is set. For this reason, line pressure pattern setting corresponds to input torque and gearshift selection. Also, line pressure characteristic corresponds to engine speed, during engine brake operation.

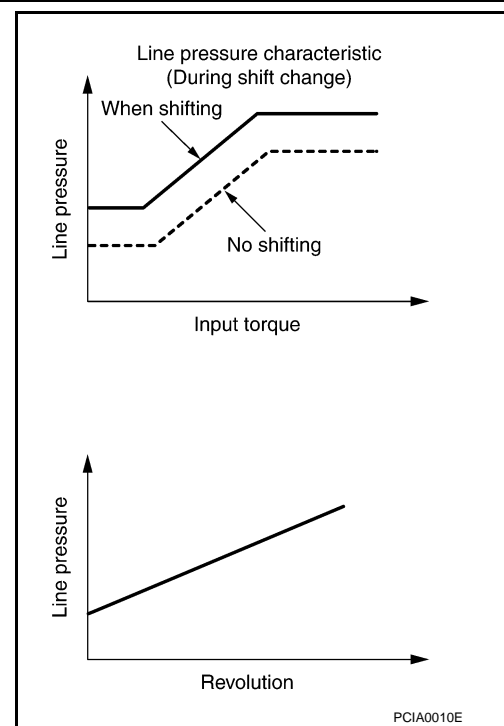

At Low Fluid Temperature

- When the A/T fluid temperature drops below the prescribed temperature, in order to speed up the action of each friction element, the line pressure is set higher than the normal line pressure characteristic.

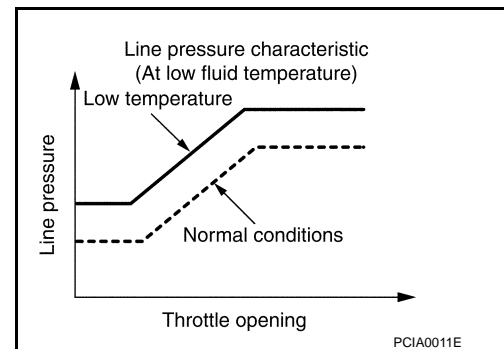

SHIFT CONTROL

The clutch pressure control solenoid is controlled by the signals from the switches and sensors. Thus, the clutch pressure is adjusted to be appropriate to the engine load state and vehicle driving state. It becomes possible to finely control the clutch hydraulic pressure with high precision and a smoother shift change characteristic is attained.

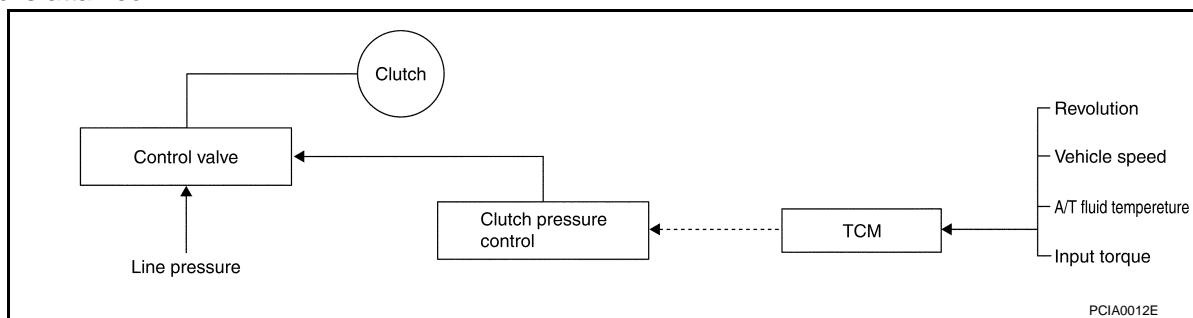

Shift Change

The clutch is controlled with the optimum timing and oil pressure by the engine speed, engine torque information, etc.

Shift Change System Diagram

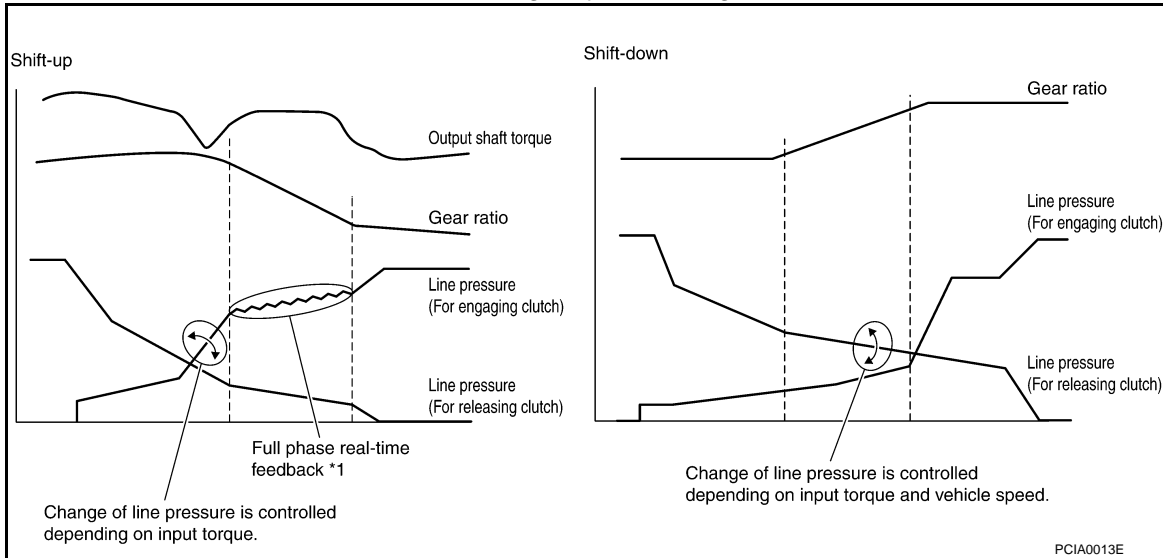

*1: Full phase real-time feedback control monitors movement of gear ratio at gear change, and controls oil pressure in real-time to achieve the best gear ratio.

Blipping Control

This system makes transmission clutch engage readily by controlling (synchronizing) engine revolution according to the (calculation of) engine revolution after shifting down.

- “BLIPPING CONTROL” functions.
 - When downshifting by accelerator pedal depression at “D” position.
 - When downshifting under the manual mode.
- TCM selects “BLIPPING CONTROL” or “NORMAL SHIFT CONTROL” according to the gear position, the selector lever position, the engine torque and the speed when accelerating by pedal depression.
- Revolution control demand signal is transmitted from TCM to ECM under “BLIPPING CONTROL”.
- TCM synchronizes engine revolution according to the revolution control demand signal.

Shift Change System Diagram

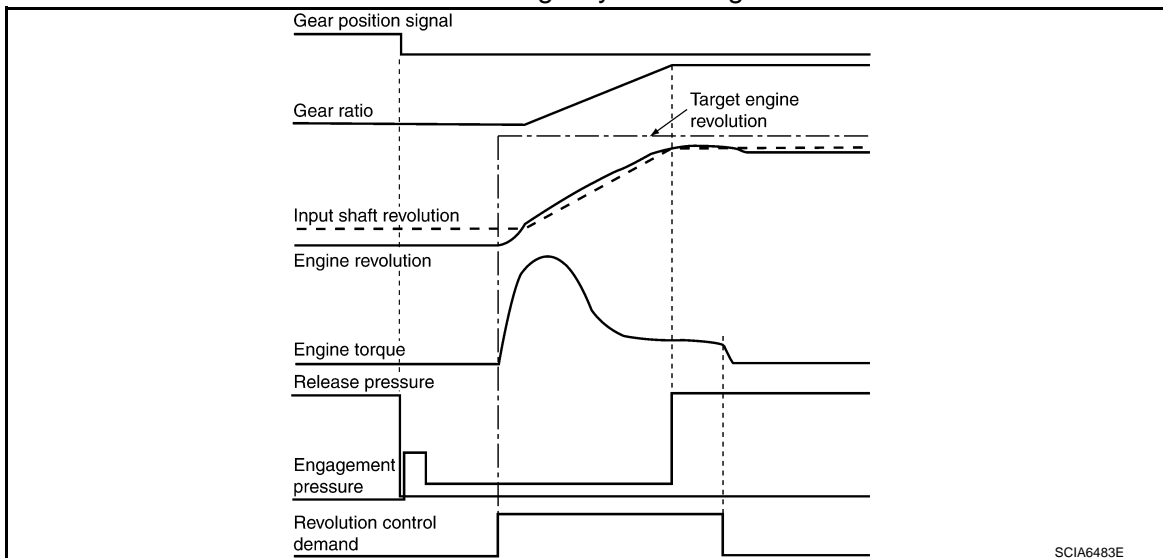

ASC (Adoptive Shift Control)

ASC automatically shifts or hold at the 2GR, 3GR or 4GR on certain roads (up/down slope and curve) and driving condition.

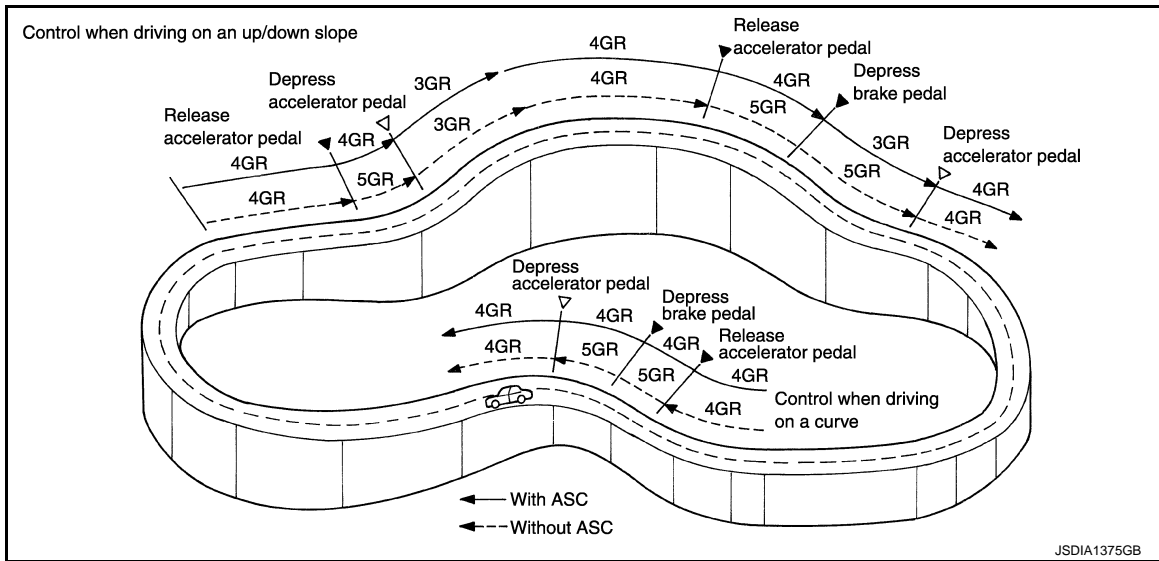

When Driving On an Up/Down Slope

- ASC judges up/down slope according to engine torque data transmitted from the ECM and vehicle speed. Fixing at 3GR or 4GR on an up-slope prevents shift hunting and controls the vehicle to gain optimum driving force. On a down-slope, automatic shift-down to the 3GR or 4GR controls to gain optimum engine brake.

When Driving On a Curve

- TCM receives the lateral G sensor signal from the ABS actuator control unit. It locks to 3GR or 4GR position in moderate cornering or to the 2GR position in sharp cornering based on this signal. This prevents any upshift and kickdown during cornering, maintaining smooth vehicle travel.

DS Mode

- Changes to the shift schedule that mainly utilizes the high engine speed zone when ASC is active.
- DS mode can be switched according to the following method.
 - When the selector lever is in the "D" position, shifting the selector lever to manual shift gate enables switching to DS mode.
 - When in DS mode, shifting the selector lever to the main gate enables to cancel DS mode.

LOCK-UP CONTROL

The torque converter clutch piston in the torque converter is engaged to eliminate torque converter slip to increase power transmission efficiency.

The torque converter clutch control valve operation is controlled by the torque converter clutch solenoid valve, which is controlled by a signal from TCM, and the torque converter clutch control valve engages or releases the torque converter clutch piston.

Lock-up operation condition table

Selector lever	"D" position			"M" position		
	5	4	3	5	4	3
Lock-up	×	—	—	×	×	×
Slip lock-up	×	×	×	—	—	—

Torque Converter Clutch Control Valve Control

Lock-up control system diagram

A/T CONTROL SYSTEM

< SYSTEM DESCRIPTION >

[5AT: RE5R05A]

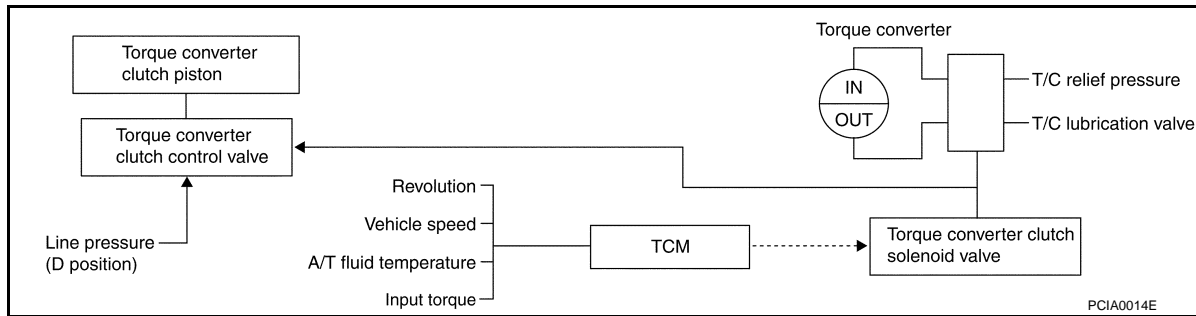

Lock-up Released

- In the lock-up released state, the torque converter clutch control valve is set into the unlocked state by the torque converter clutch solenoid and the lock-up apply pressure is drained. In this way, the torque converter clutch piston is not coupled.

Lock-up Applied

- In the lock-up applied state, the torque converter clutch control valve is set into the locked state by the torque converter clutch solenoid and lock-up apply pressure is generated. In this way, the torque converter clutch piston is pressed and coupled.

Smooth Lock-up Control

When shifting from the lock-up released state to the lock-up applied state, the current output to the torque converter clutch solenoid is controlled with the TCM. In this way, when shifting to the lock-up applied state, the torque converter clutch is temporarily set to the half-clutched state to reduce the shock.

Half-clutched State

- The current output from the TCM to the torque converter clutch solenoid is varied to steadily increase the torque converter clutch solenoid pressure. In this way, the lock-up apply pressure gradually rises and while the torque converter clutch piston is put into half-clutched states, the torque converter clutch piston operating pressure is increased and the coupling is completed smoothly.

Slip Lock-up Control

- In the slip region, the torque converter clutch solenoid current is controlled with the TCM to put it into the half-clutched state. This absorbs the engine torque fluctuation and lock-up operates from low speed. This raises the fuel efficiency for 3GR, 4GR and 5GR at both low speed and when the accelerator has a low degree of opening.

ENGINE BRAKE CONTROL

- The forward one-way clutch transmits the drive force from the engine to the rear wheels. But the reverse drive from the rear wheels is not transmitted to the engine because the one-way clutch is idling. Therefore, the low coast brake solenoid is operated to prevent the forward one-way clutch from idling and the engine brake is operated in the same manner as conventionally.

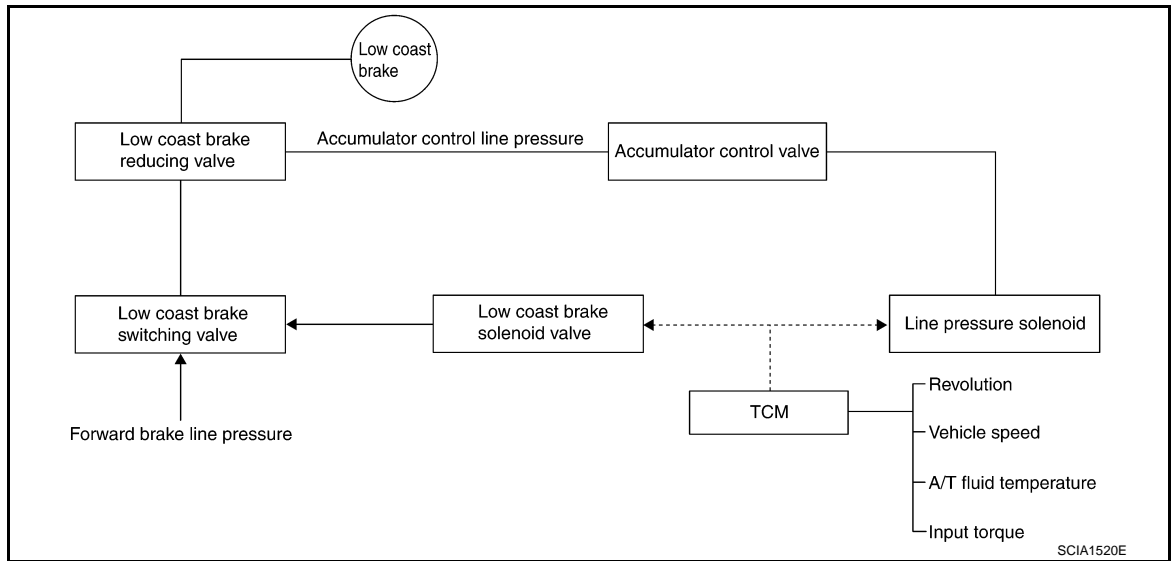

- The operation of the low coast brake solenoid switches the low coast brake switching valve and controls the coupling and releasing of the low coast brake.
The low coast brake reducing valve controls the low coast brake coupling force.

A
B
C
TM
E
F
G
H
I
J
K
L
M
N
O
P

Component Parts Location

INFOID:000000004342867

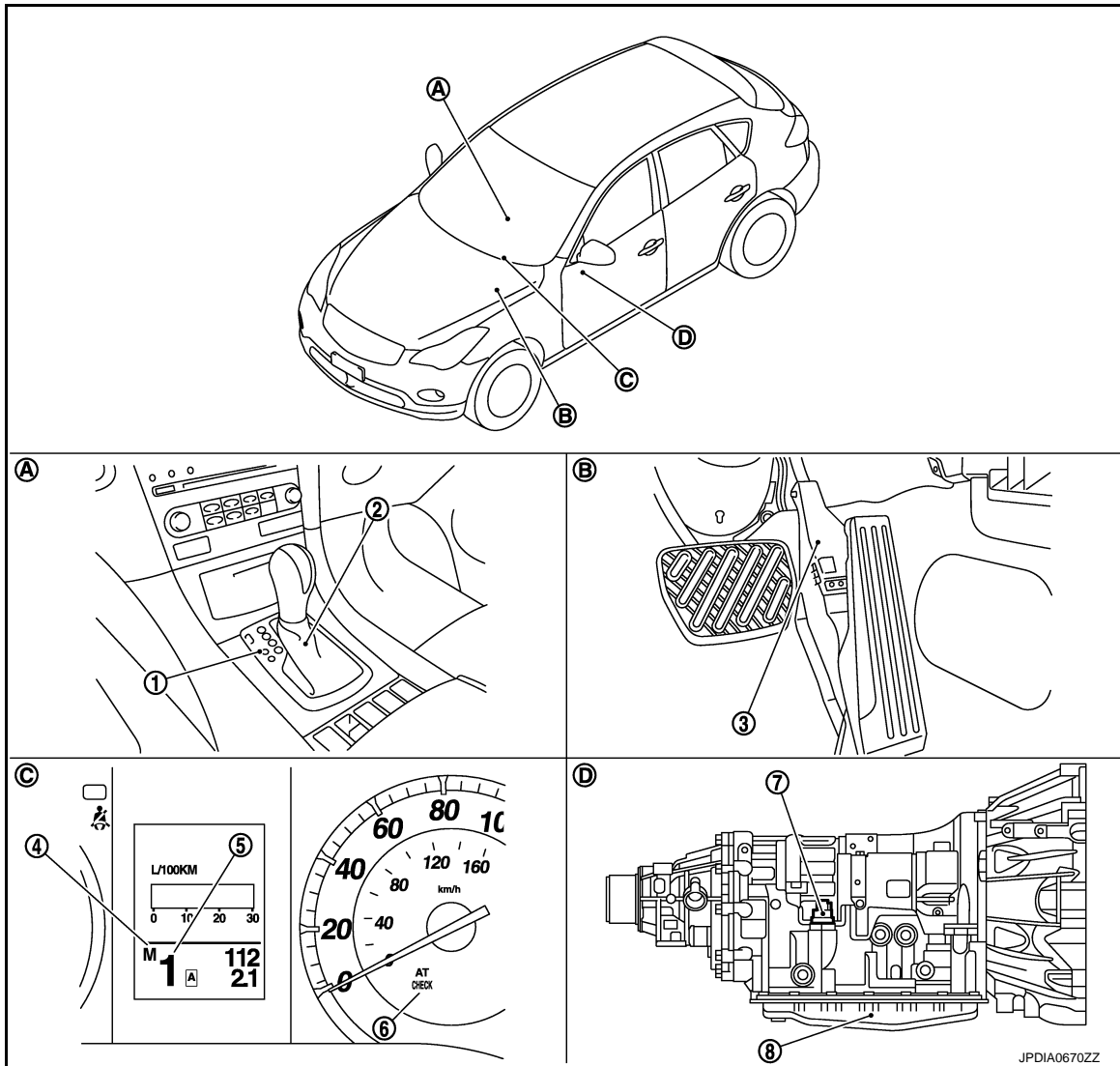

- | | | |
|--------------------------------------|--------------------------------|--------------------------------------|
| 1. Selector lever position indicator | 2. A/T shift selector assembly | 3. Accelerator pedal position sensor |
| 4. Manual mode indicator | 5. Shift position indicator | 6. A/T CHECK indicator lamp |
| 7. A/T assembly connector | 8. Control valve with TCM* | |
| A. Center console | B. Accelerator pedal | C. Combination meter |
| D. A/T assembly | | |

*: Control valve with TCM is included in A/T assembly.

NOTE:

- The following components are included in A/T shift selector assembly (2).
 - Manual mode select switch
 - Manual mode position select switch
 - Shift position switch
- The following components are included in control valve with TCM* (8).
 - TCM
 - Input speed sensor 1, 2
 - Output speed sensor
 - A/T fluid temperature sensor 1, 2
 - Transmission range switch
 - Line pressure solenoid valve
 - Torque converter clutch solenoid valve
 - Direct clutch solenoid valve

A/T CONTROL SYSTEM

< SYSTEM DESCRIPTION >

[5AT: RE5R05A]

- High and low reverse clutch solenoid valve
- Input clutch solenoid valve
- Front brake solenoid valve
- Low coast brake solenoid valve
- ATF pressure switch 2

Component Description

INFOID:000000004342868

Name	Function
TCM	TM-48, "Description"
Transmission range switch	TM-49, "Description"
Output speed sensor	TM-52, "Description"
Input speed sensor 1	TM-51, "Description"
Input speed sensor 2	
A/T fluid temperature sensor 1	TM-71, "Description"
A/T fluid temperature sensor 2	
Input clutch solenoid valve	TM-77, "Description"
Front brake solenoid valve	TM-78, "Description"
Direct clutch solenoid valve	TM-79, "Description"
High and low reverse clutch solenoid valve	TM-80, "Description"
Low coast brake solenoid valve	TM-81, "Description"
ATF pressure switch 2 (LC/B)	Detects any malfunction in the low coast brake hydraulic pressure. When it detects any malfunction, it puts the system into fail-safe mode.
Torque converter regulator valve	In order to prevent the pressure supplied to the torque converter from being excessive, the line pressure is adjusted to the optimum pressure (torque converter operating pressure).
Pressure regulator valve Pressure regulator plug Pressure regulator sleeve	Adjusts the oil discharged from the oil pump to the optimum pressure (line pressure) for the driving state.
Front brake control valve	When the front brake is coupled, adjusts the line pressure to the optimum pressure (front brake pressure) and supplies it to the front brake. (In 1GR, 2GR, 3GR, and 5GR, adjusts the clutch pressure.)
Accumulator control valve	Adjusts the pressure (accumulator control pressure) acting on the accumulator piston and low coast reducing valve to the pressure appropriate to the driving state.
Pilot valve A	Adjusts the line pressure and produces the constant pressure (pilot pressure) required for line pressure control, shift change control, and lock-up control.
Pilot valve B	Adjusts the line pressure and produces the constant pressure (pilot pressure) required for shift change control.
Low coast brake switching valve	During engine braking, supplies the line pressure to the low coast brake reducing valve.
Low coast brake reducing valve	When the low coast brake is coupled, adjusts the line pressure to the optimum pressure (low coast brake pressure) and supplies it to the low coast brake.
N-R accumulator	Produces the stabilizing pressure for when N-R is selected.
Direct clutch piston switching valve	Operates in 4GR and switches the direct clutch coupling capacity.
High and low reverse clutch control valve	When the high and low reverse clutch is coupled, adjusts the line pressure to the optimum pressure (high and low reverse clutch pressure) and supplies it to the high and low reverse clutch. (In 1GR, 3GR, 4GR and 5GR, adjusts the clutch pressure.)
Input clutch control valve	When the input clutch is coupled, adjusts the line pressure to the optimum pressure (input clutch pressure) and supplies it to the input clutch. (In 4GR and 5GR, adjusts the clutch pressure.)
Direct clutch control valve	When the direct clutch is coupled, adjusts the line pressure to the optimum pressure (direct clutch pressure) and supplies it to the direct clutch. (In 2GR, 3GR, and 4GR, adjusts the clutch pressure.)

A/T CONTROL SYSTEM

< SYSTEM DESCRIPTION >

[5AT: RE5R05A]

Name	Function
TCC control valve TCC control plug TCC control sleeve	Switches the lock-up to operating or released. Also, by performing the lock-up operation transiently, lock-up smoothly.
Torque converter lubrication valve	Operates during lock-up to switch the torque converter, cooling, and lubrication system oil passage.
Cool by-pass valve	Allows excess oil to bypass cooler circuit without being fed into it.
Line pressure relief valve	Discharges excess oil from line pressure circuit.
N-D accumulator	Produces the stabilizing pressure for when N-D is selected.
Manual valve	Transmits line pressure to each circuit according to the select position. The circuits to which the line pressure is not transmitted drain.
Accelerator pedal position sensor	TM-70, "Description"
Throttle position sensor	
Manual mode switch	TM-84, "Description"
Starter relay	TM-46, "Description"

SHIFT MECHANISM

< SYSTEM DESCRIPTION >

[5AT: RE5R05A]

SHIFT MECHANISM

Cross-Sectional View

INFOID:000000004342869

2WD MODELS

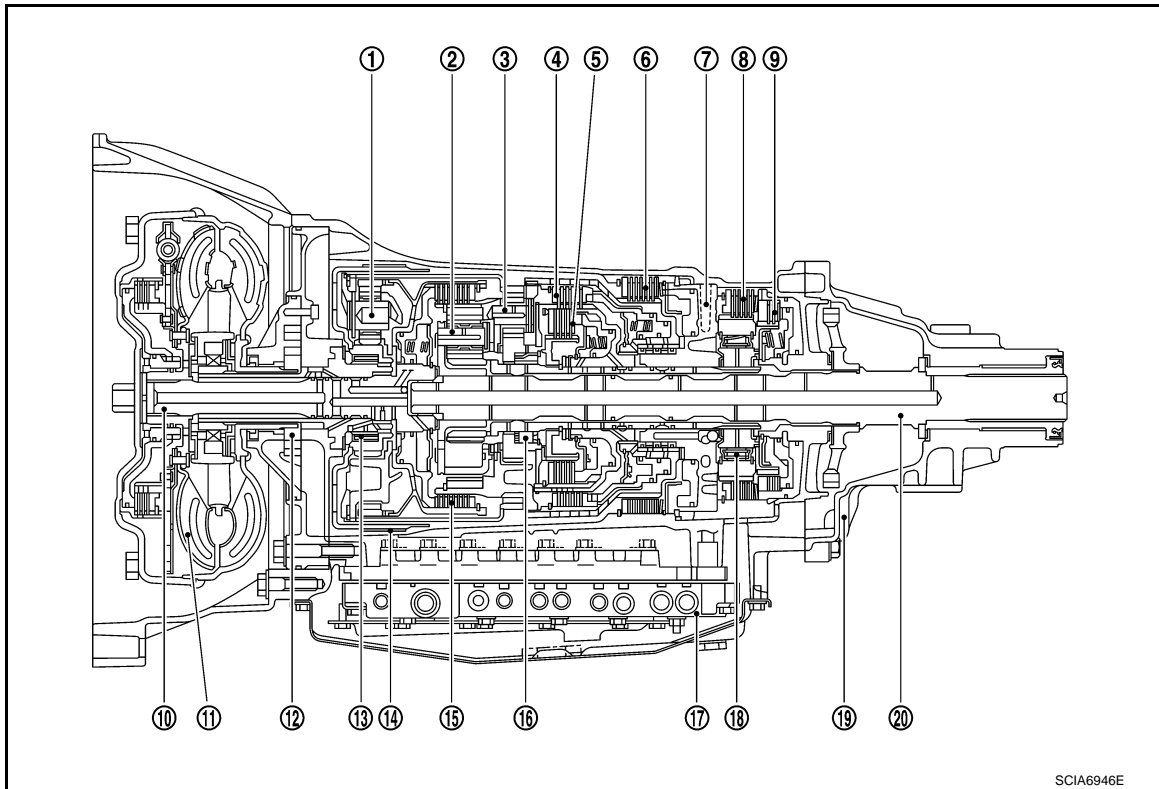

- | | | |
|-------------------------|--------------------------------|----------------------------|
| 1. Front planetary gear | 2. Mid planetary gear | 3. Rear planetary gear |
| 4. Direct clutch | 5. High and low reverse clutch | 6. Reverse brake |
| 7. Drum support | 8. Forward brake | 9. Low coast brake |
| 10. Input shaft | 11. Torque converter | 12. Oil pump |
| 13. 3rd one-way clutch | 14. Front brake | 15. Input clutch |
| 16. 1st one-way clutch | 17. Control valve with TCM | 18. Forward one-way clutch |
| 19. Rear extension | 20. Output shaft | |

AWD MODELS

A
B
C
TM
E
F
G
H
I
J
K
L
M
N
O
P

SHIFT MECHANISM

< SYSTEM DESCRIPTION >

[5AT: RE5R05A]

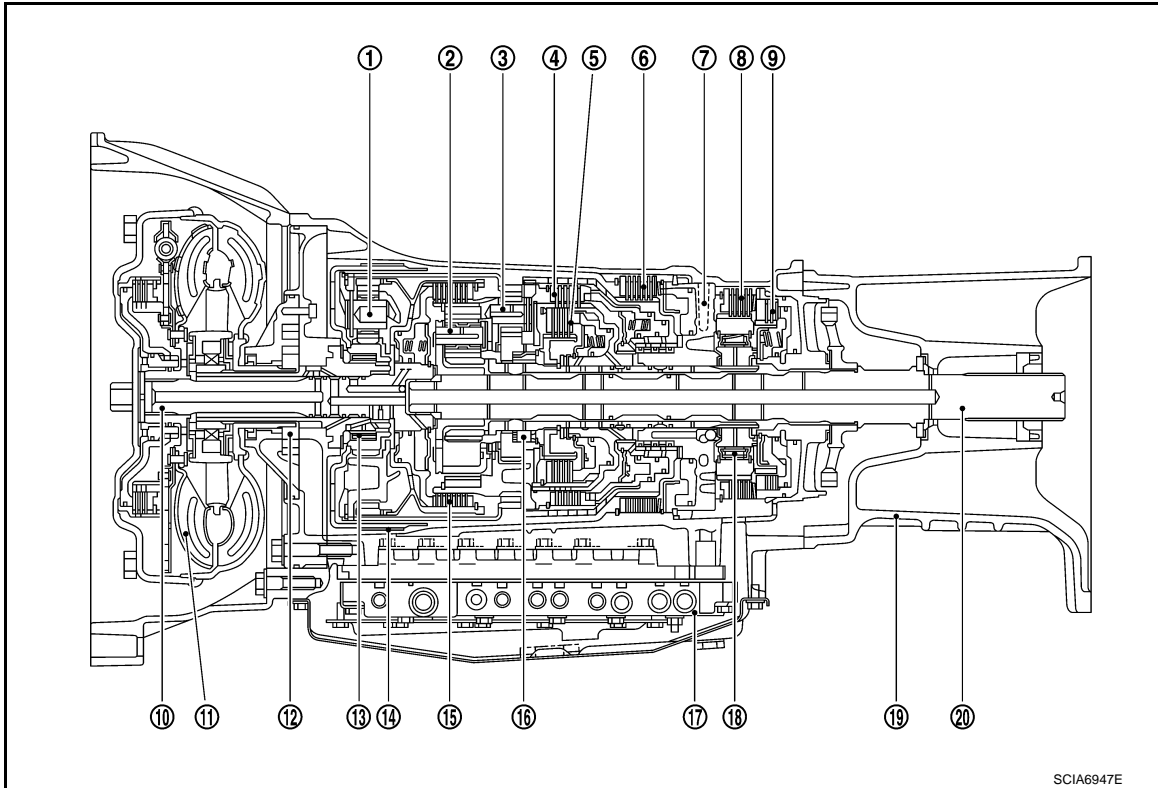

SCIA6947E

- | | | |
|-------------------------|--------------------------------|----------------------------|
| 1. Front planetary gear | 2. Mid planetary gear | 3. Rear planetary gear |
| 4. Direct clutch | 5. High and low reverse clutch | 6. Reverse brake |
| 7. Drum support | 8. Forward brake | 9. Low coast brake |
| 10. Input shaft | 11. Torque converter | 12. Oil pump |
| 13. 3rd one-way clutch | 14. Front brake | 15. Input clutch |
| 16. 1st one-way clutch | 17. Control valve with TCM | 18. Forward one-way clutch |
| 19. Adapter case | 20. Output shaft | |

System Diagram

INFOID:000000004342870

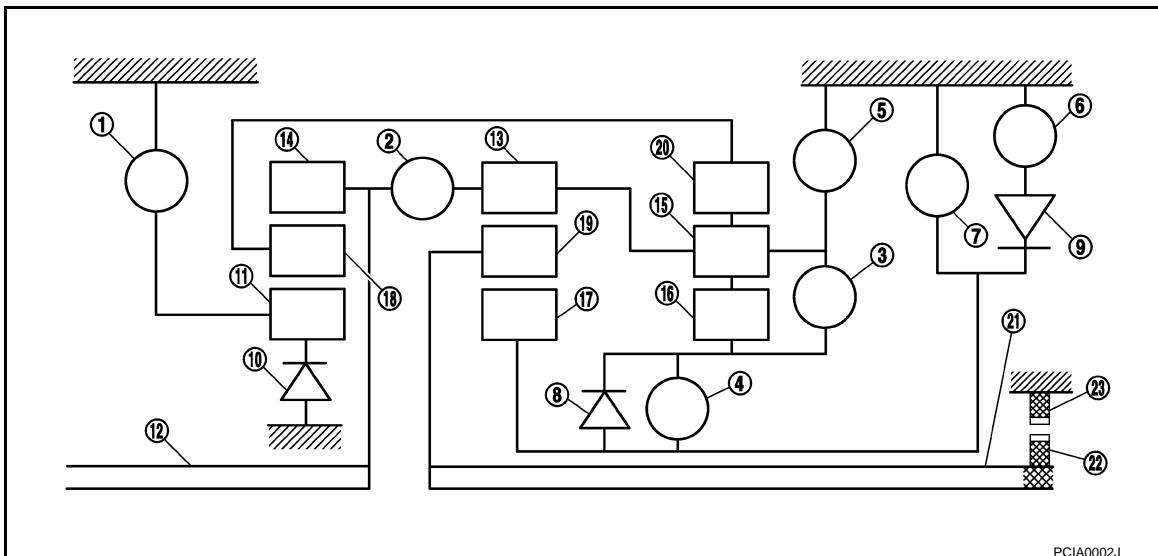

PCIA0002J

- | | | |
|--------------------------------|------------------|------------------|
| 1. Front brake | 2. Input clutch | 3. Direct clutch |
| 4. High and low reverse clutch | 5. Reverse brake | 6. Forward brake |

SHIFT MECHANISM

< SYSTEM DESCRIPTION >

[5AT: RE5R05A]

- | | | |
|------------------------|-------------------------|---------------------------|
| 7. Low coast brake | 8. 1st one-way clutch | 9. Forward one-way clutch |
| 10. 3rd one-way clutch | 11. Front sun gear | 12. Input shaft |
| 13. Mid internal gear | 14. Front internal gear | 15. Rear carrier |
| 16. Rear sun gear | 17. Mid sun gear | 18. Front carrier |
| 19. Mid carrier | 20. Rear internal gear | 21. Output shaft |
| 22. Parking gear | 23. Parking pawl | |

A

B

System Description

INFOID:000000004342871

C

DESCRIPTION

With the use of 3 sets of planetary gears, A/T enables 5-speed transmission for forward and 1-speed transmission for backward, depending on the combination of 3 sets of multiple-disc clutches, 3 sets of multiple-disc brakes, a brake band, and 3 sets of one-way clutches.

TM

CLUTCH AND BAND CHART

E

F

G

H

I

J

K

L

M

N

O

P

SHIFT MECHANISM

< SYSTEM DESCRIPTION >

[5AT: RE5R05A]

Shift position	I/C	HLR/C	D/C	R/B	FR/B	LC/B	Fwd/B	1st OWC	Fwd OWC	3rd OWC	Remarks
P		△			△						PARK POSITION
R		○		○	○			◎		◎	REVERSE POSITION
N		△			△						NEUTRAL POSITION
D,DS	1 st		△*		△	△**	○	◎	◎	◎	Automatic shift 1→2→3→4→5
	2 nd			○	△		○		◎	◎	
	3 rd		○	○	○		△	◇		◎	
	4 th	○	○	○			△	◇			
	5 th	○	○		○		△	◇		◇	
M5	5 th	○	○		○		△	◇		◇	Locks* (held stationary) in 5GR
M4	4 th	○	○	○			△	◇			Locks* (held stationary) in 4GR
M3	3 rd		○	○	○		△	◇		◎	Locks* (held stationary) in 3GR
M2	2 nd			○	○	○	○		◎	◎	Locks* (held stationary) in 2GR
M1	1 st		○		○	○	○	◎	◎	◎	Locks* (held stationary) in 1GR

- * : Down shift automatically according to the vehicle speed.
- – Operates
 - ◎ – Operates during “progressive” acceleration.
 - ◇ – Operates and affects power transmission while coasting.
 - △ – Line pressure is applied but does not affect power transmission.
 - △* – Operates under conditions shown in illustration ①.
 - △** – Operates under conditions shown in illustration ②. Delay control is applied during D(4,3,2,1) → N shift

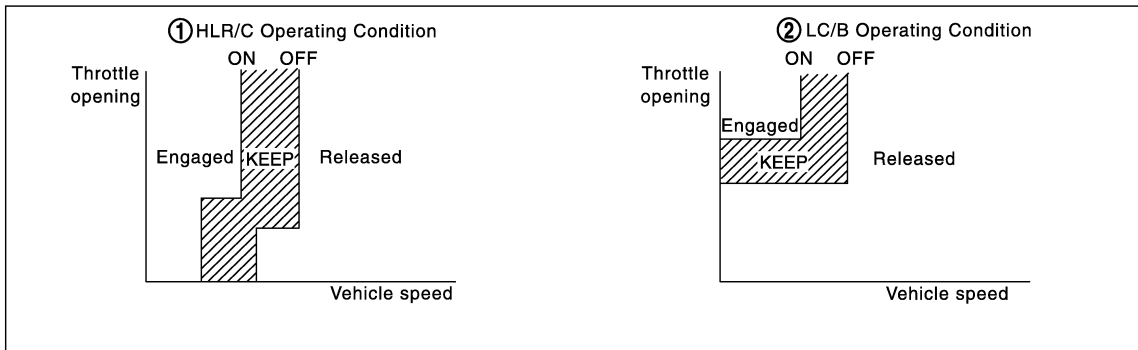

JSDIA1376GB

POWER TRANSMISSION

“N” Position

Since both the forward brake and the reverse brake are released, torque from the input shaft drive is not transmitted to the output shaft.

“P” Position

SHIFT MECHANISM

< SYSTEM DESCRIPTION >

[5AT: RE5R05A]

- The same as for the “N” position, both the forward brake and the reverse brake are released, so torque from the input shaft drive is not transmitted to the output shaft.
- The parking pawl linked with the selector lever meshes with the parking gear and fastens the output shaft mechanically.

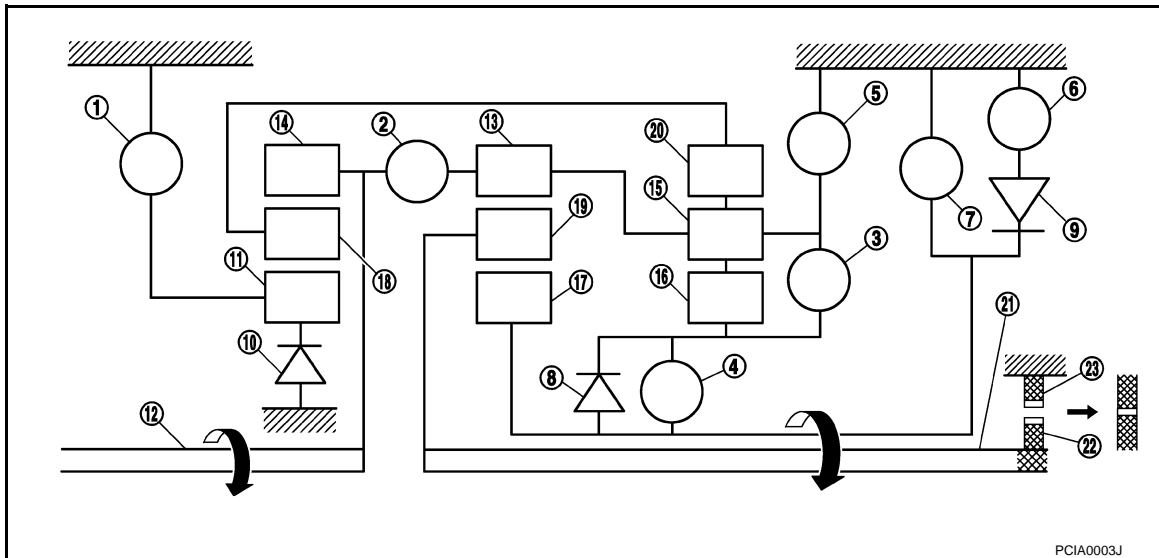

- | | | |
|--------------------------------|-------------------------|---------------------------|
| 1. Front brake | 2. Input clutch | 3. Direct clutch |
| 4. High and low reverse clutch | 5. Reverse brake | 6. Forward brake |
| 7. Low coast brake | 8. 1st one-way clutch | 9. Forward one-way clutch |
| 10. 3rd one-way clutch | 11. Front sun gear | 12. Input shaft |
| 13. Mid internal gear | 14. Front internal gear | 15. Rear carrier |
| 16. Rear sun gear | 17. Mid sun gear | 18. Front carrier |
| 19. Mid carrier | 20. Rear internal gear | 21. Output shaft |
| 22. Parking gear | 23. Parking pawl | |

“D1” and “DS1” Positions

- The forward brake and the forward one-way clutch regulate reverse rotation of the mid sun gear.
- The 1st one-way clutch regulates reverse rotation of the rear sun gear.
- The 3rd one-way clutch regulates reverse rotation of the front sun gear.
- During deceleration, the mid sun gear turns forward, so the forward one-way clutch idles and the engine brake is not activated.

SHIFT MECHANISM

< SYSTEM DESCRIPTION >

[5AT: RE5R05A]

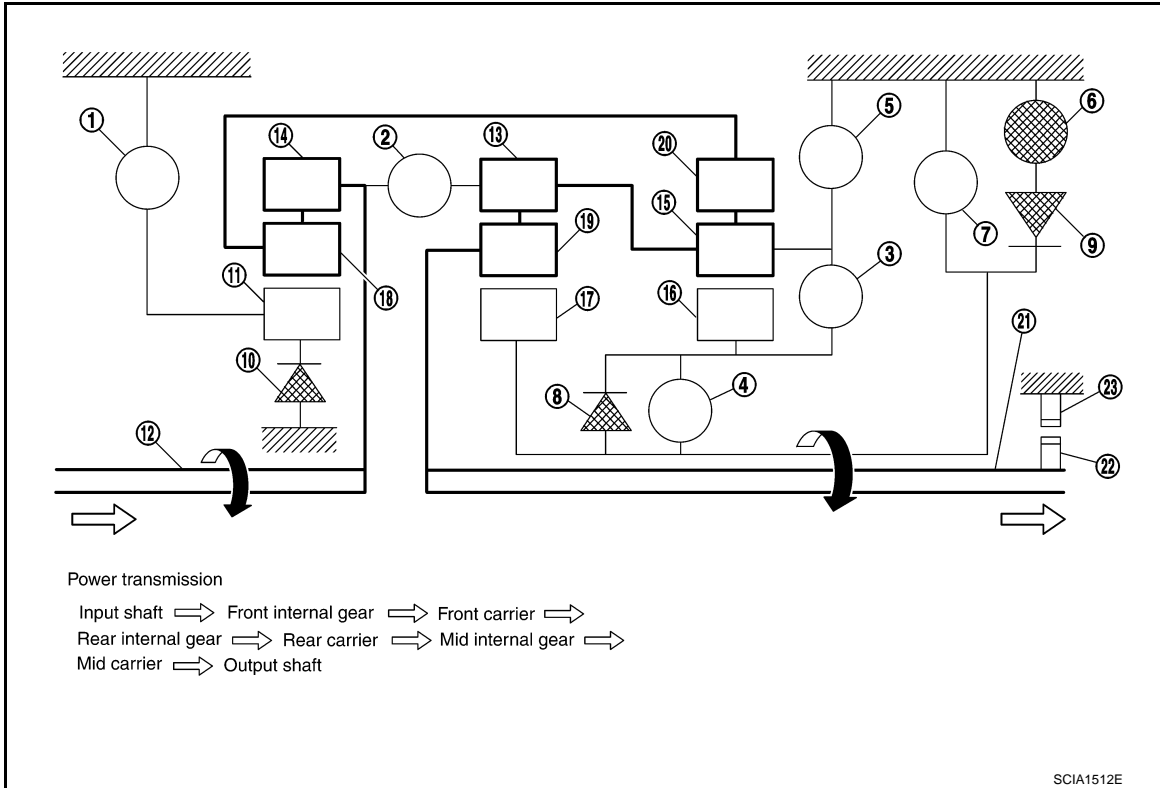

- | | | |
|--------------------------------|-------------------------|---------------------------|
| 1. Front brake | 2. Input clutch | 3. Direct clutch |
| 4. High and low reverse clutch | 5. Reverse brake | 6. Forward brake |
| 7. Low coast brake | 8. 1st one-way clutch | 9. Forward one-way clutch |
| 10. 3rd one-way clutch | 11. Front sun gear | 12. Input shaft |
| 13. Mid internal gear | 14. Front internal gear | 15. Rear carrier |
| 16. Rear sun gear | 17. Mid sun gear | 18. Front carrier |
| 19. Mid carrier | 20. Rear internal gear | 21. Output shaft |
| 22. Parking gear | 23. Parking pawl | |

"M1" Position

- The front brake fastens the front sun gear.
- The forward brake and the forward one-way clutch regulate reverse rotation of the mid sun gear.
- High and low reverse clutch connects the rear sun gear and the mid sun gear.
- The low coast brake fastens the mid sun gear.
- During deceleration, the low coast brake regulates forward rotation of the mid sun gear and the engine brake functions.

SHIFT MECHANISM

< SYSTEM DESCRIPTION >

[5AT: RE5R05A]

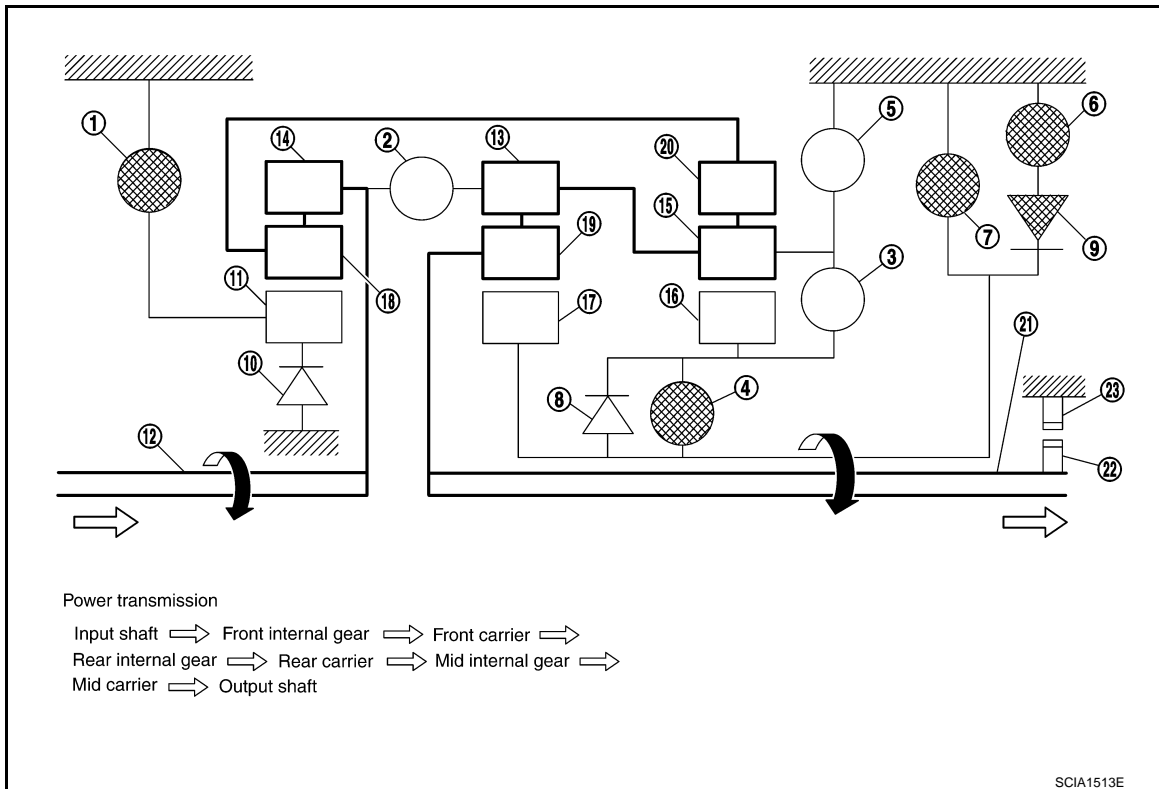

- | | | |
|--------------------------------|-------------------------|---------------------------|
| 1. Front brake | 2. Input clutch | 3. Direct clutch |
| 4. High and low reverse clutch | 5. Reverse brake | 6. Forward brake |
| 7. Low coast brake | 8. 1st one-way clutch | 9. Forward one-way clutch |
| 10. 3rd one-way clutch | 11. Front sun gear | 12. Input shaft |
| 13. Mid internal gear | 14. Front internal gear | 15. Rear carrier |
| 16. Rear sun gear | 17. Mid sun gear | 18. Front carrier |
| 19. Mid carrier | 20. Rear internal gear | 21. Output shaft |
| 22. Parking gear | 23. Parking pawl | |

“D2” and “DS2” Positions

- The forward brake and the forward one-way clutch regulate reverse rotation of the mid sun gear.
- The 3rd one-way clutch regulates reverse rotation of the front sun gear.
- The direct clutch is coupled, and the rear carrier and rear sun gear are connected.
- During deceleration, the mid sun gear turns forward, so the forward one-way clutch idles and engine brake is not activated.

SHIFT MECHANISM

< SYSTEM DESCRIPTION >

[5AT: RE5R05A]

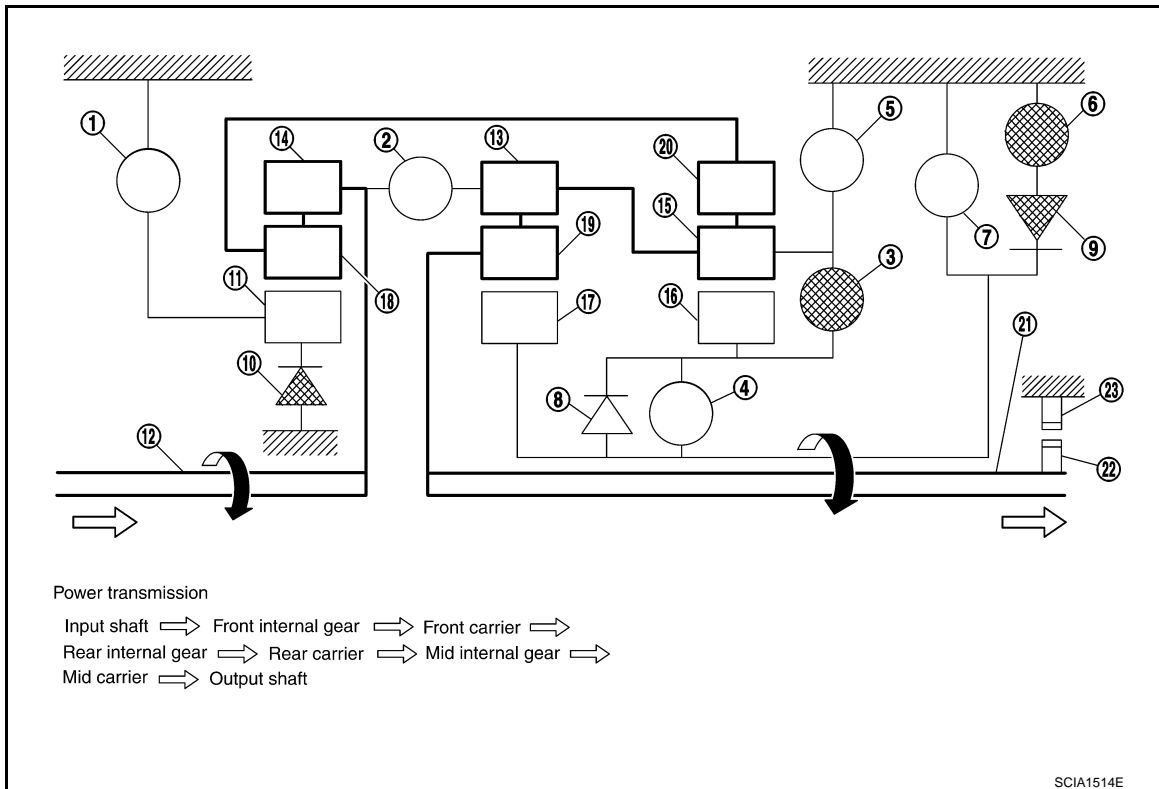

- | | | |
|--------------------------------|-------------------------|---------------------------|
| 1. Front brake | 2. Input clutch | 3. Direct clutch |
| 4. High and low reverse clutch | 5. Reverse brake | 6. Forward brake |
| 7. Low coast brake | 8. 1st one-way clutch | 9. Forward one-way clutch |
| 10. 3rd one-way clutch | 11. Front sun gear | 12. Input shaft |
| 13. Mid internal gear | 14. Front internal gear | 15. Rear carrier |
| 16. Rear sun gear | 17. Mid sun gear | 18. Front carrier |
| 19. Mid carrier | 20. Rear internal gear | 21. Output shaft |
| 22. Parking gear | 23. Parking pawl | |

"M2" Position

- The front brake fastens the front sun gear.
- The forward brake and the forward one-way clutch regulate reverse rotation of the mid sun gear.
- The direct clutch is coupled, and the rear carrier and rear sun gear are connected.
- The low coast brake fastens the mid sun gear.
- During deceleration, the low coast brake regulates forward rotation of the mid sun gear and the engine brake functions.

SHIFT MECHANISM

< SYSTEM DESCRIPTION >

[5AT: RE5R05A]

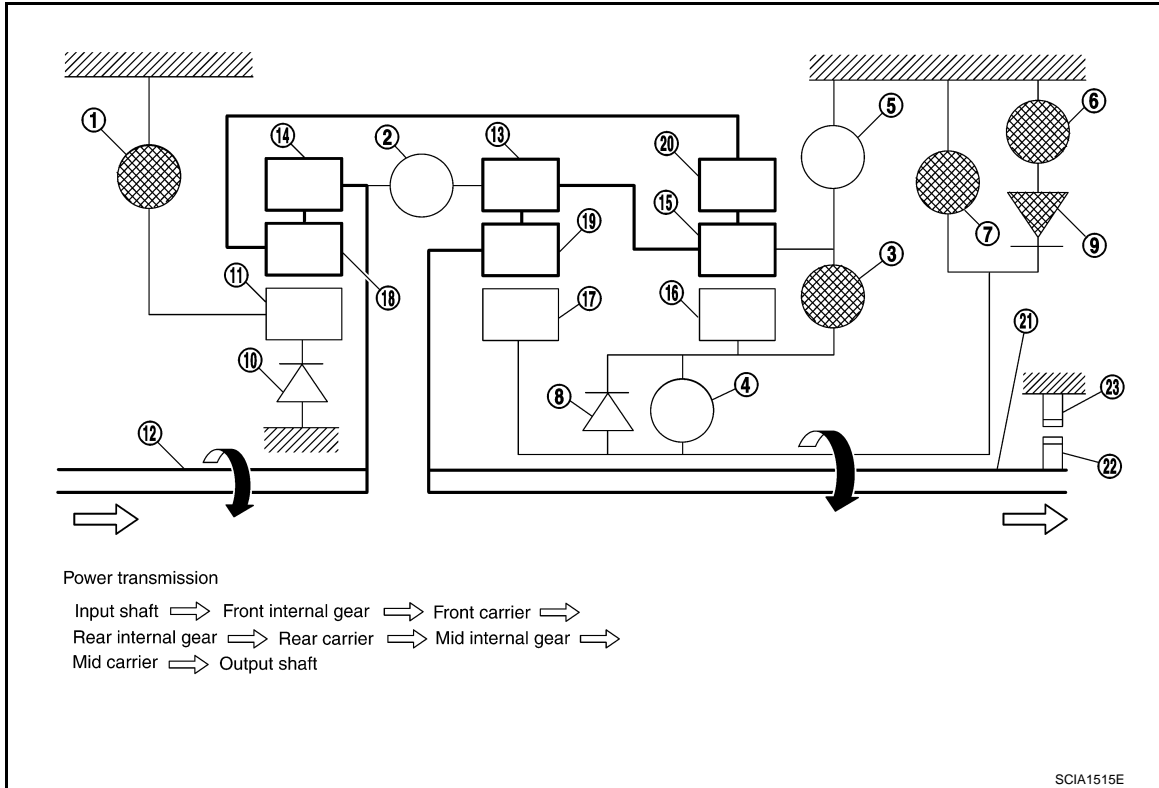

- | | | |
|--------------------------------|-------------------------|---------------------------|
| 1. Front brake | 2. Input clutch | 3. Direct clutch |
| 4. High and low reverse clutch | 5. Reverse brake | 6. Forward brake |
| 7. Low coast brake | 8. 1st one-way clutch | 9. Forward one-way clutch |
| 10. 3rd one-way clutch | 11. Front sun gear | 12. Input shaft |
| 13. Mid internal gear | 14. Front internal gear | 15. Rear carrier |
| 16. Rear sun gear | 17. Mid sun gear | 18. Front carrier |
| 19. Mid carrier | 20. Rear internal gear | 21. Output shaft |
| 22. Parking gear | 23. Parking pawl | |

“D3”, “DS3” and “M3” Positions

- The front brake fastens the front sun gear.
- The direct clutch is coupled, and the rear carrier and rear sun gear are connected.
- The high and low reverse clutch is coupled, and the mid sun gear and rear sun gear are connected.

A
B
C
TM
E
F
G
H
I
J
K
L
M
N
O
P

SHIFT MECHANISM

< SYSTEM DESCRIPTION >

[5AT: RE5R05A]

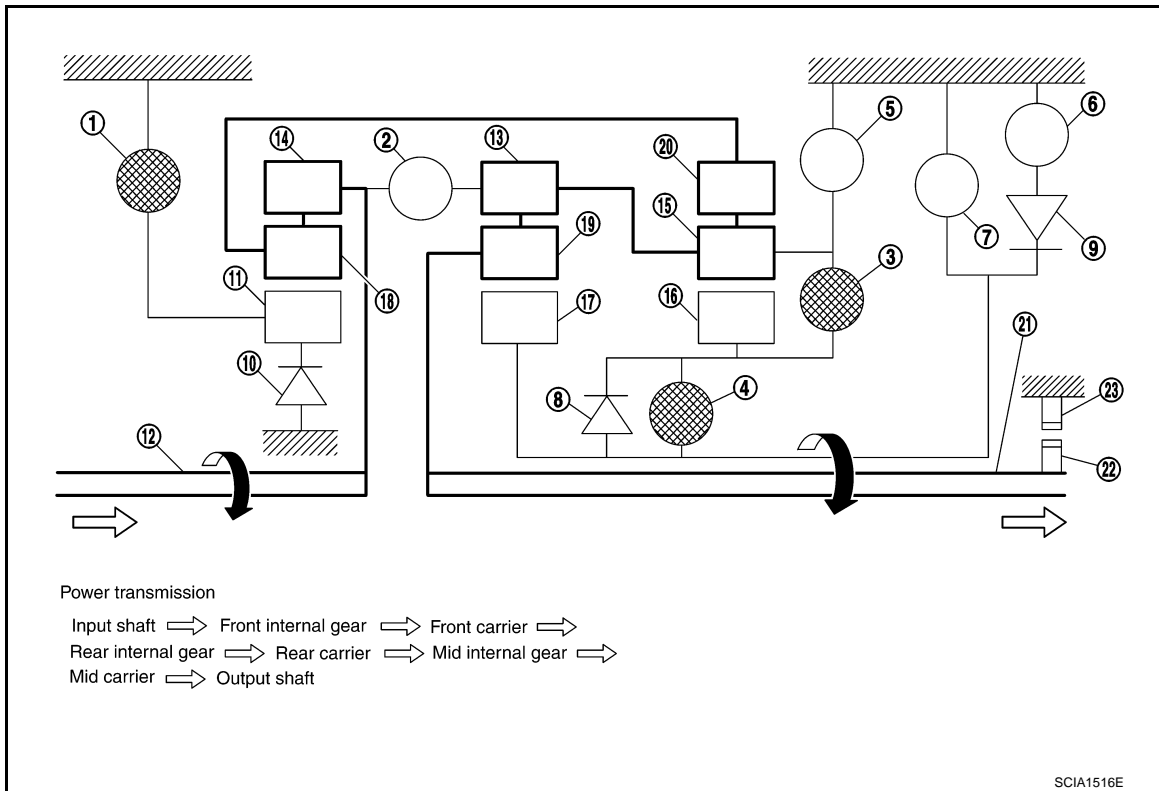

- | | | |
|--------------------------------|-------------------------|---------------------------|
| 1. Front brake | 2. Input clutch | 3. Direct clutch |
| 4. High and low reverse clutch | 5. Reverse brake | 6. Forward brake |
| 7. Low coast brake | 8. 1st one-way clutch | 9. Forward one-way clutch |
| 10. 3rd one-way clutch | 11. Front sun gear | 12. Input shaft |
| 13. Mid internal gear | 14. Front internal gear | 15. Rear carrier |
| 16. Rear sun gear | 17. Mid sun gear | 18. Front carrier |
| 19. Mid carrier | 20. Rear internal gear | 21. Output shaft |
| 22. Parking gear | 23. Parking pawl | |

“D4”, “DS4” and “M4” Positions

- The direct clutch is coupled, and the rear carrier and rear sun gear are connected.
- The high and low reverse clutch is coupled, and the mid sun gear and rear sun gear are connected.
- The input clutch is coupled, and the front internal gear and mid internal gear are connected.
- The drive power is conveyed to the front internal gear, mid internal gear, and rear carrier and the three planetary gears rotate forward as one unit.

SHIFT MECHANISM

< SYSTEM DESCRIPTION >

[5AT: RE5R05A]

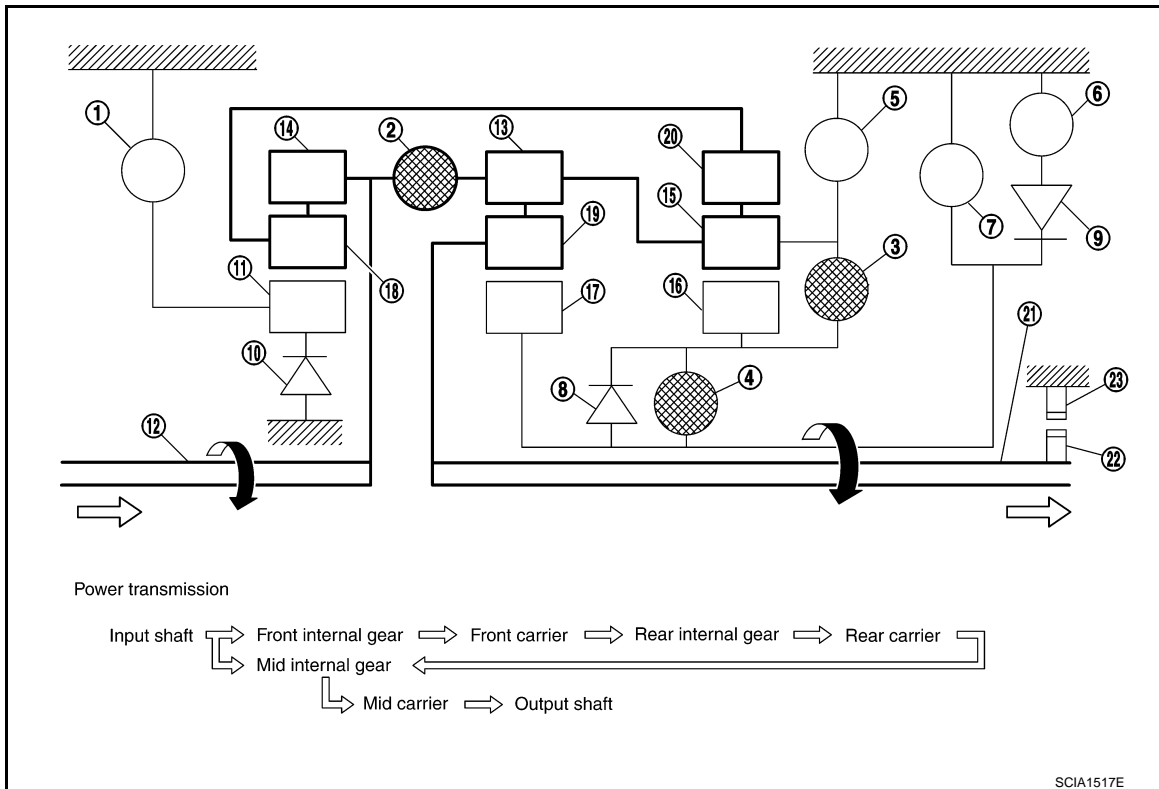

- | | | |
|--------------------------------|-------------------------|---------------------------|
| 1. Front brake | 2. Input clutch | 3. Direct clutch |
| 4. High and low reverse clutch | 5. Reverse brake | 6. Forward brake |
| 7. Low coast brake | 8. 1st one-way clutch | 9. Forward one-way clutch |
| 10. 3rd one-way clutch | 11. Front sun gear | 12. Input shaft |
| 13. Mid internal gear | 14. Front internal gear | 15. Rear carrier |
| 16. Rear sun gear | 17. Mid sun gear | 18. Front carrier |
| 19. Mid carrier | 20. Rear internal gear | 21. Output shaft |
| 22. Parking gear | 23. Parking pawl | |

"D5", "DS5" and "M5" Positions

- The front brake fastens the front sun gear.
- The input clutch is coupled, and the front internal gear and mid internal gear are connected.
- The high and low reverse clutch is coupled, and the mid sun gear and rear sun gear are connected.

A
B
C
TM
E
F
G
H
I
J
K
L
M
N
O
P

SHIFT MECHANISM

< SYSTEM DESCRIPTION >

[5AT: RE5R05A]

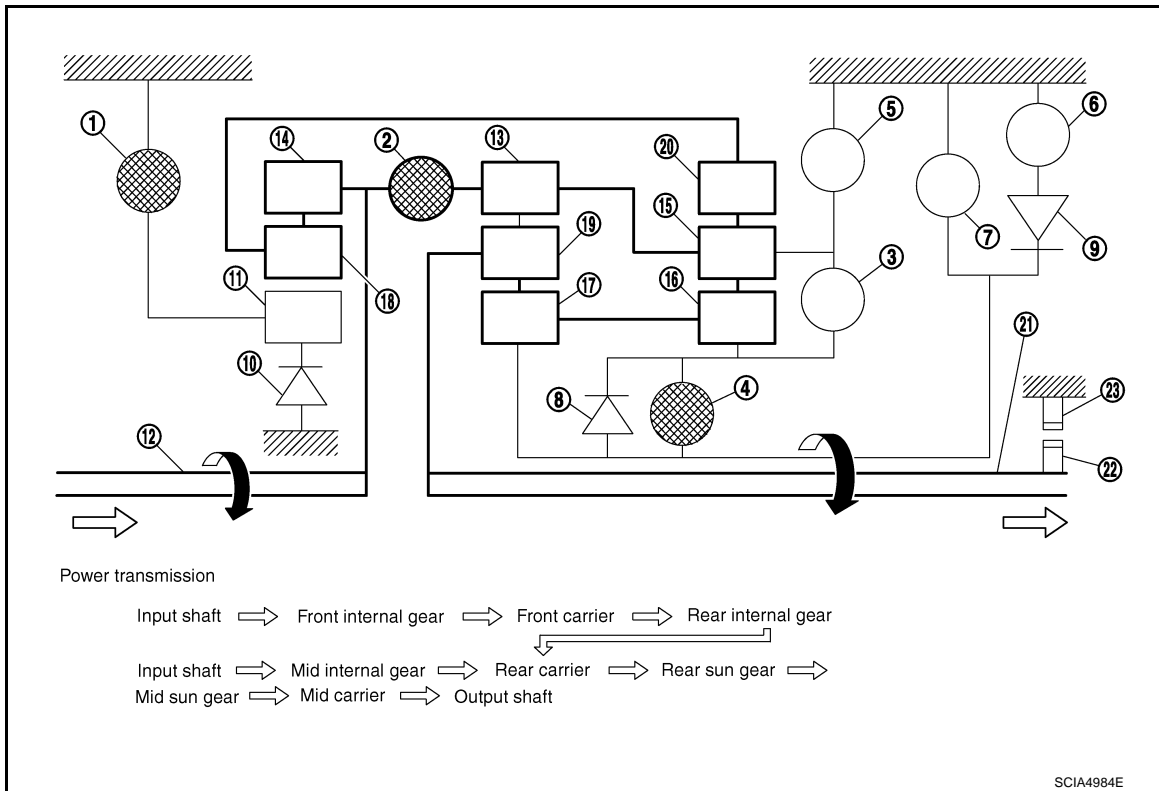

- | | | |
|--------------------------------|-------------------------|---------------------------|
| 1. Front brake | 2. Input clutch | 3. Direct clutch |
| 4. High and low reverse clutch | 5. Reverse brake | 6. Forward brake |
| 7. Low coast brake | 8. 1st one-way clutch | 9. Forward one-way clutch |
| 10. 3rd one-way clutch | 11. Front sun gear | 12. Input shaft |
| 13. Mid internal gear | 14. Front internal gear | 15. Rear carrier |
| 16. Rear sun gear | 17. Mid sun gear | 18. Front carrier |
| 19. Mid carrier | 20. Rear internal gear | 21. Output shaft |
| 22. Parking gear | 23. Parking pawl | |

"R" Position

- The front brake fastens the front sun gear.
- The high and low reverse clutch is coupled, and the mid sun gear and rear sun gear are connected.
- The reverse brake fastens the rear carrier.

SHIFT MECHANISM

< SYSTEM DESCRIPTION >

[5AT: RE5R05A]

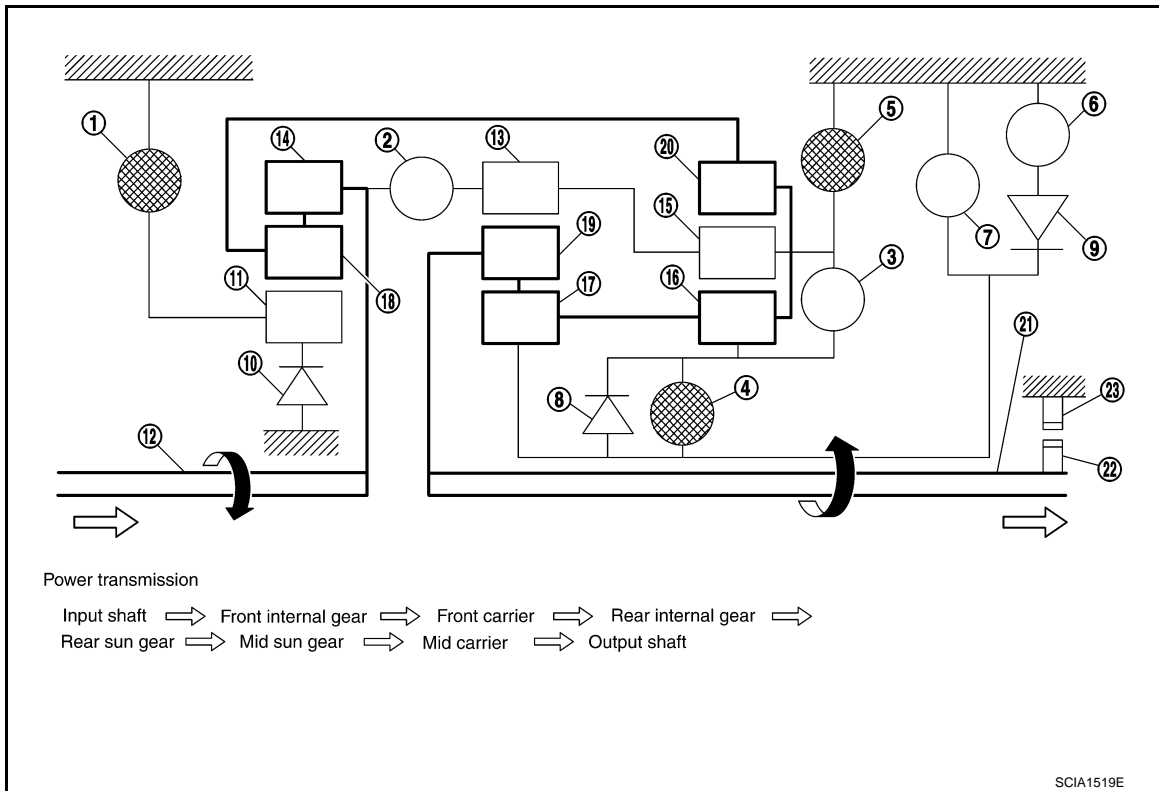

- | | | |
|--------------------------------|-------------------------|---------------------------|
| 1. Front brake | 2. Input clutch | 3. Direct clutch |
| 4. High and low reverse clutch | 5. Reverse brake | 6. Forward brake |
| 7. Low coast brake | 8. 1st one-way clutch | 9. Forward one-way clutch |
| 10. 3rd one-way clutch | 11. Front sun gear | 12. Input shaft |
| 13. Mid internal gear | 14. Front internal gear | 15. Rear carrier |
| 16. Rear sun gear | 17. Mid sun gear | 18. Front carrier |
| 19. Mid carrier | 20. Rear internal gear | 21. Output shaft |
| 22. Parking gear | 23. Parking pawl | |

A
B
C
TM
E
F
G
H
I
J
K
L
M
N
O
P

SHIFT MECHANISM

< SYSTEM DESCRIPTION >

[5AT: RE5R05A]

Component Parts Location

INFOID:000000004342872

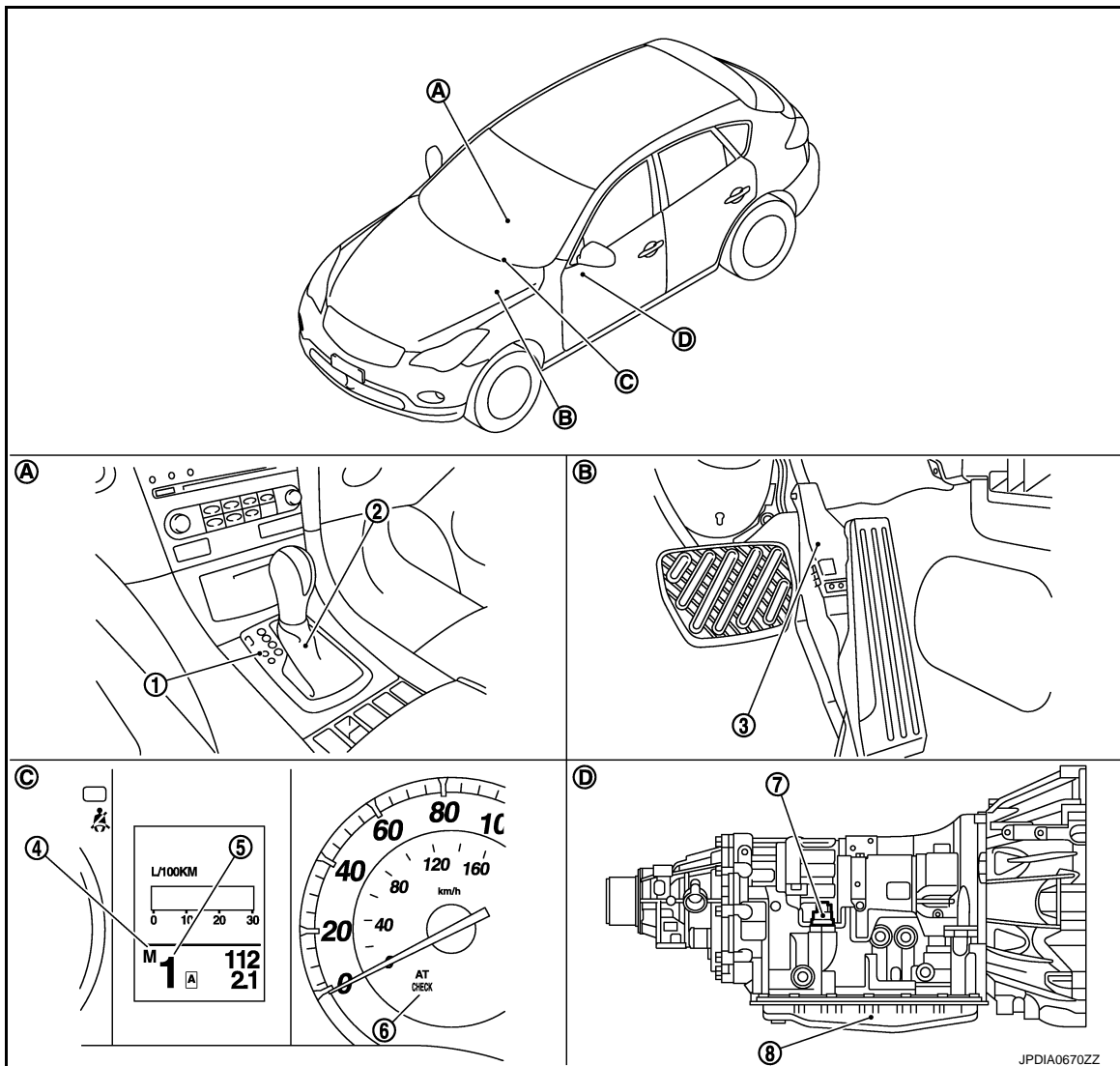

- | | | |
|--------------------------------------|--------------------------------|--------------------------------------|
| 1. Selector lever position indicator | 2. A/T shift selector assembly | 3. Accelerator pedal position sensor |
| 4. Manual mode indicator | 5. Shift position indicator | 6. A/T CHECK indicator lamp |
| 7. A/T assembly harness connector | 8. Control valve with TCM* | |
| A. Center console | B. Accelerator pedal | C. Combination meter |
| D. A/T assembly | | |

*: Control valve with TCM is included in A/T assembly.

NOTE:

- The following components are included in A/T shift selector assembly (2).
 - Manual mode select switch
 - Manual mode position select switch
 - Shift position switch
- The following components are included in control valve with TCM* (8).
 - TCM
 - Input speed sensor 1, 2
 - Output speed sensor
 - A/T fluid temperature sensor 1, 2
 - Transmission range switch
 - Line pressure solenoid valve
 - Torque converter clutch solenoid valve
 - Direct clutch solenoid valve

SHIFT MECHANISM

< SYSTEM DESCRIPTION >

[5AT: RE5R05A]

- High and low reverse clutch solenoid valve
- Input clutch solenoid valve
- Front brake solenoid valve
- Low coast brake solenoid valve
- ATF pressure switch 2

Component Description

INFOID:000000004342873

Name of the Part (Abbreviation)	Function
Front brake (FR/B)	Fastens the front sun gear.
Input clutch (I/C)	Connects the input shaft, the front internal gear and the mid internal gear.
Direct clutch (D/C)	Connects the rear carrier and the rear sun gear.
High and low reverse clutch (HLR/C)	Connects the mid sun gear and the rear sun gear.
Reverse brake (R/B)	Fastens the rear carrier.
Forward brake (Fwd/B)	Fastens the mid sun gear.
Low coast brake (LC/B)	Fastens the mid sun gear.
1st one-way clutch (1st OWC)	Allows the rear sun gear to turn freely forward relative to the mid sun gear but fastens it for reverse rotation.
Forward one-way clutch (Fwd OWC)	Allows the mid sun gear to turn freely in the forward direction but fastens it for reverse rotation.
3rd one-way clutch (3rd OWC)	Allows the front sun gear to turn freely in the forward direction but fastens it for reverse rotation.
Torque converter	Amplifies driving force the engine, and transmits it to transmission input shaft.
Oil pump	Driven by the engine, oil pump supplies oil to torque converter, control valve assembly, and each lubricating system.

A
B
C
TM
E
F
G
H
I
J
K
L
M
N
O
P

SHIFT LOCK SYSTEM

< SYSTEM DESCRIPTION >

[5AT: RE5R05A]

SHIFT LOCK SYSTEM

System Description

INFOID:000000004342874

The selector lever cannot be shifted from the “P” position unless the brake pedal is depressed while the ignition switch is ON.

The shift lock is unlocked by the shift lock unit that is activated when the ignition switch is ON and the stop lamp switch is turned ON (brake pedal is depressed).

Therefore, the shift lock unit receives no ON signal and the shift lock remains locked if the above conditions are not fulfilled. (However, a shift operation is allowed if the shift lock release button is pressed.)

SHIFT LOCK OPERATION AT “P” POSITION

When Brake Pedal Is Not Depressed (No Shift Operation Allowed)

The shift lock solenoid (A) inside the shift lock unit is not energized if the brake pedal is not depressed while the ignition switch is ON.

The lock plate (B) lowers according to the downward movement of the position pin (C) when the selector button (D) is pressed, and presses only slider B (E) into the shift lock unit. Slider A (F) located below the lock plate prevents the downward movement of the lock plate with the spring force. The selector lever cannot be shifted from the “P” position for this reason.

However, slider A is forcibly pressed into the shift lock unit, allowing the selector lever to shift if the shift lock release button is pressed.

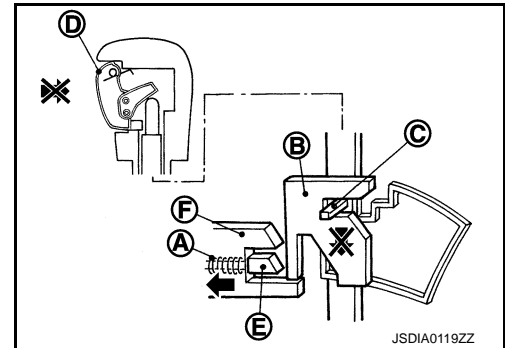

When Brake Pedal Is Depressed (Shift Operation Allowed)

The shift lock solenoid (A) inside the shift lock unit is energized and the relative positions of sliders A (B) and B (C) are maintained when the brake pedal is depressed while the ignition switch is ON.

The lock plate (D) lowers according to the downward movement of the position pin (E), thrusting away sliders A and B, when the selector button (F) is pressed.

The position pin lowers to the position that allows shift operation for this reason. As a result, the selector lever can be shifted out of the P position.

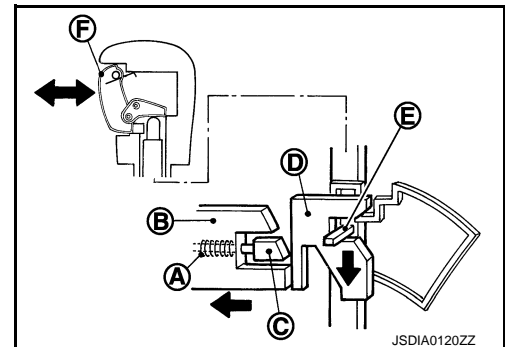

OPERATION AT OTHER THAN “P” POSITION

The shift lock function will not operate at any position other than “P” because the lock plate (A) is only set for the “P” position. Accordingly, the selector lever can be shifted to any position regardless of the brake operation.

The position pin (B) enters the “P” position thrusting away the lock plate when the selector lever is shifted to the “P” position. Then, the shift mechanism is locked when the selector button (C) is released.

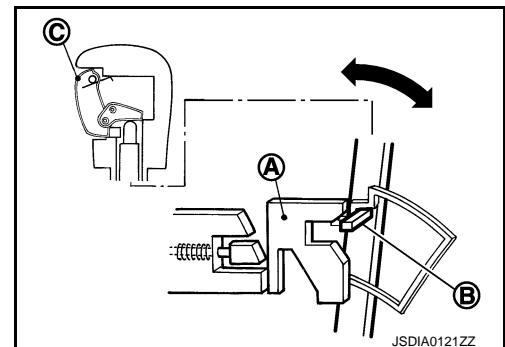

“P” POSITION RETAINING MECHANISM (IGNITION SWITCH LOCK)

When ignition switch is not in the ON position, power is not applied to the shift lock solenoid in the shift lock unit. This causes shift lock state, and then “P” position is retained.

When an actuating system in the shift lock unit has a malfunction, selector lever is unable to operate from the “P” position even when pressing the brake pedal with the ignition switch ON. However, when pressing the shift lock release button, slider A is forcibly pressed into the shift lock unit. This allows shift lock to be released and selector lever enables the select operation from the “P” position.

CAUTION:

Do not use the shift lock release button except when the select lever is inoperative even when pressing the brake pedal with the ignition switch ON.

SHIFT LOCK SYSTEM

< SYSTEM DESCRIPTION >

[5AT: RE5R05A]

Component Parts Location

INFOID:000000004342875

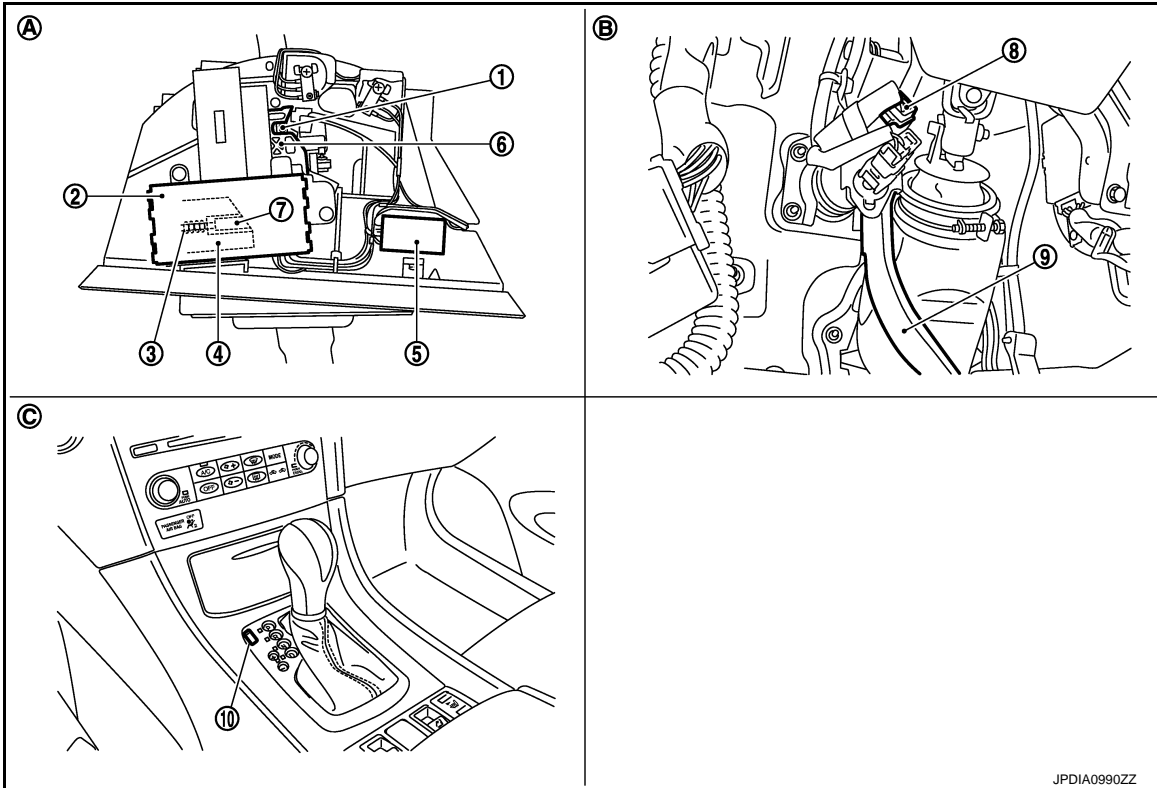

- | | | |
|--------------------------------|---------------------------------|------------------------|
| 1. Position pin | 2. Shift lock unit | 3. Shift lock solenoid |
| 4. Slider A | 5. A/T shift selector connector | 6. Lock plate |
| 7. Slider B | 8. Stop lamp switch | 9. Brake pedal |
| 10. Shift lock cover * | | |
| A. A/T shift selector assembly | B. Brake pedal, upper | C. Center console |

*: Shift lock release button becomes operative by removing shift lock cover.

Component Description

INFOID:000000004342876

Component		Function
A/T shift selector assembly	Shift lock unit	Shift lock solenoid Activated by the ignition switch and stop lamp signals, it holds the relative positions of sliders A and B.
		Lock plate The lock plate restricts the position pin stroke by selector button operation according to the shift lock unit status.
		Shift lock release button Pressing the shift lock release button cancels the shift lock forcibly.
	Position pin	The position pin, linking with the selector button, restricts the selector lever movement.
Stop lamp switch		Depressing the brake pedal turns ON the stop lamp switch and energizes the shift lock relay.

ON BOARD DIAGNOSTIC (OBD) SYSTEM

Diagnosis Description

INFOID:000000004342877

DESCRIPTION

The A/T system has two self-diagnostic systems.

The first is the emission-related on board diagnostic system (OBD-II) performed by the TCM in combination with the ECM. The malfunction is indicated by the MIL (malfunction indicator lamp) and is stored as a DTC in the ECM memory but not the TCM memory.

The second is the TCM original self-diagnosis indicated by the A/T CHECK indicator lamp. The malfunction is stored in the TCM memory. The detected items are overlapped with OBD-II self-diagnostic items. For detail, refer to [TM-40. "CONSULT-III Function \(TRANSMISSION\)"](#).

OBD-II FUNCTION

The ECM provides emission-related on board diagnostic (OBD-II) functions for the A/T system. One function is to receive a signal from the TCM used with OBD-related parts of the A/T system. The signal is transmitted to the ECM when a malfunction occurs in the corresponding OBD-related part. The other function is to indicate a diagnostic result by means of the MIL (malfunction indicator lamp) on the instrument panel. Sensors, switches and solenoid valves are used as sensing elements.

The MIL automatically illuminates in "One or Two Trip Detection Logic" when a malfunction is sensed in relation to A/T system parts.

ONE OR TWO TRIP DETECTION LOGIC OF OBD-II

One Trip Detection Logic

If a malfunction is sensed during the first test drive, the MIL illuminates and the ECM memory stores the malfunction as a DTC. The TCM is not provided with such a memory function.

Two Trip Detection Logic

When a malfunction is sensed during the first test drive, it is stored in the ECM memory as a 1st trip DTC (diagnostic trouble code) or 1st trip freeze frame data. At this point, the MIL does not illuminate. — 1st trip
If the same malfunction as that experienced during the first test drive is sensed during the second test drive, the MIL will illuminate. — 2nd trip

The "trip" in the "One or Two Trip Detection Logic" means a driving mode in which self-diagnosis is performed during vehicle operation.

OBD-II DIAGNOSTIC TROUBLE (DTC)

How to Read DTC and 1st Trip DTC

DTC and 1st trip DTC can be read by the following methods.

( **With CONSULT-III** or ( **GST**) CONSULT-III or GST (Generic Scan Tool) Examples: P0705, P0720 etc.

These DTC are prescribed by SAE J2012.

(CONSULT-III also displays the malfunctioning component or system.)

- **1st trip DTC No. is the same as DTC No.**
- **Output of the diagnostic trouble code indicates that the indicated circuit has a malfunction. However, in case of the Mode II and GST, they do not indicate whether the malfunction is still occurring or occurred in the past and returned to normal.**
CONSULT-III can identify them as shown below, therefore, CONSULT-III (if available) is recommended.

Freeze Frame Data and 1st Trip Freeze Frame Data

The ECM has a memory function, which stores the driving condition such as fuel system status, calculated load value, engine coolant temperature, short term fuel trim, long term fuel trim, engine speed and vehicle speed at the moment the ECM detects a malfunction.

Data which are stored in the ECM memory, along with the 1st trip DTC, are called 1st trip freeze frame data, and the data, stored together with the DTC data, are called freeze frame data and displayed on CONSULT-III or GST. The 1st trip freeze frame data can only be displayed on the CONSULT-III screen, not on the GST. For detail, refer to [EC-117. "CONSULT-III Function"](#).

Only one set of freeze frame data (either 1st trip freeze frame data or freeze frame data) can be stored in the ECM. 1st trip freeze frame data is stored in the ECM memory along with the 1st trip DTC. There is no priority for 1st trip freeze frame data and it is updated each time a different 1st trip DTC is detected. However, once freeze frame data (2nd trip detection/MIL on) is stored in the ECM memory, 1st trip freeze frame data is no

ON BOARD DIAGNOSTIC (OBD) SYSTEM

< SYSTEM DESCRIPTION >

[5AT: RE5R05A]

longer stored. Remember, only one set of freeze frame data can be stored in the ECM. The ECM has the following priorities to update the data.

Priority	Items	
1	Freeze frame data	Misfire — DTC: P0300 - P0306 Fuel Injection System Function — DTC: P0171, P0172, P0174, P0175
2		Except the above items (Includes A/T related items)
3	1st trip freeze frame data	

Both 1st trip freeze frame data and freeze frame data (along with the DTC) are cleared when the ECM memory is erased.

How to Erase DTC

The diagnostic trouble code can be erased by CONSULT-III, GST or ECM DIAGNOSTIC TEST MODE as described following.

- **If the battery cable is disconnected from the terminal, the DTC will be lost within 24 hours.**
- **When you erase the DTC, using CONSULT-III or GST is easier and quicker than switching the mode selector on the ECM.**

The following emission-related diagnostic information is cleared from the ECM memory when erasing DTC related to OBD-II. For details, refer to [EC-534, "DTC Index"](#).

- **Diagnostic trouble codes (DTC)**
- **1st trip diagnostic trouble codes (1st trip DTC)**
- **Freeze frame data**
- **1st trip freeze frame data**
- **System readiness test (SRT) codes**
- **Test values**

How to Erase DTC (With CONSULT-III)

1. The emission related diagnostic information in the TCM and ECM can be erased by selecting "All Erase" in the "Description" of "FINAL CHECK" mode with CONSULT-III.

How to Erase DTC (With GST)

1. If the ignition switch stays ON after repair work, be sure to turn ignition switch OFF once. Wait at least 10 seconds and then turn it ON (engine stopped) again.
2. Perform "Erase Self-diagnosis". Refer to [TM-39, "Diagnosis Description"](#).
3. Perform "How to Erase DTC (WITH GST)". Refer to [EC-104, "Diagnosis Description"](#).

How to Erase DTC (No tools)

1. If the ignition switch stays ON after repair work, be sure to turn ignition switch OFF once. Wait at least 10 seconds and then turn it ON (engine stopped) again.
2. Perform "Erase Self-diagnosis". Refer to [TM-39, "Diagnosis Description"](#).
3. Perform "How to Erase DTC (No tools)". Refer to [EC-104, "Diagnosis Description"](#).

OBD-II SELF-DIAGNOSTIC PROCEDURE (WITH GST)

Refer to [EC-126, "Diagnosis Tool Function"](#).

OBD-II SELF-DIAGNOSTIC PROCEDURE (NO TOOLS)

Refer to "MALFUNCTION INDICATOR LAMP (MIL)". Refer to [EC-104, "Diagnosis Description"](#).

MALFUNCTION INDICATOR LAMP (MIL)

Description

ON BOARD DIAGNOSTIC (OBD) SYSTEM

< SYSTEM DESCRIPTION >

[5AT: RE5R05A]

- The MIL is located on the combination meters.
1. The MIL will light up when the ignition switch is turned ON without the engine running. This is a bulb check. If the MIL does not light up, refer to [EC-482. "Component Function Check"](#).
 2. When the engine is started, the MIL should go off. If the MIL remains on, the on board diagnostic system has detected engine system malfunction.

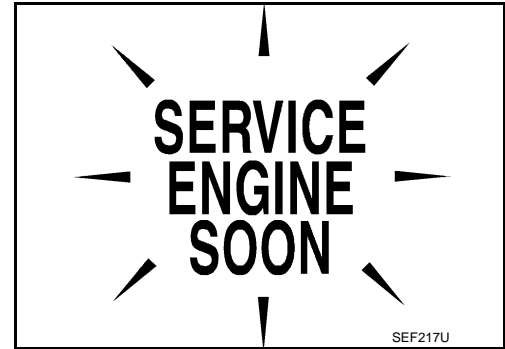

DIAGNOSIS SYSTEM (TCM)

Diagnosis Description

INFOID:000000004342878

 TCM SELF-DIAGNOSTIC PROCEDURE (NO TOOLS)

Description

As a method for locating the suspected circuit, when the self-diagnostics start signal is input, the memory for the malfunction location is output and the A/T CHECK indicator lamp flashes to display the corresponding DTC.

Operation Procedure

1. Start the engine with selector lever in "P" position. Warm engine to normal operating temperature.
2. Turn ignition switch ON and OFF at least twice, then leave it in the OFF position.
3. Wait 10 seconds.
4. Turn ignition switch ON. (Do not start the engine.)
5. Check A/T CHECK indicator lamp comes on for about 2 seconds.

CAUTION:

If A/T CHECK indicator lamp does not come on, refer to [TM-112. "Symptom Table"](#).

6. Turn ignition switch OFF.
7. Keep pressing shift lock release button.
8. Shift the selector lever from "P" to "D" position.
9. Release accelerator pedal. (Set the closed throttle position signal ON.)
10. Depress brake pedal. (Stop lamp switch signal ON.)
11. Turn ignition switch ON. (Do not start the engine.)
12. Wait 3 seconds.
13. Shift the selector lever to the manual shift gate side. (Manual mode signal ON.)
14. Release brake pedal. (Stop lamp switch signal OFF.)
15. Shift the selector lever to "D" position. (Manual mode signal OFF.)
16. Depress brake pedal. (Stop lamp switch signal ON.)
17. Release brake pedal. (Stop lamp switch signal OFF.)
18. Depress accelerator pedal fully and release it.
19. Check A/T CHECK indicator lamp. Refer to "Judgment Self-diagnosis Code".

CAUTION:

If the system does not go into self-diagnosis, refer to [TM-112. "Symptom Table"](#).

Judgment Self-diagnosis Code

DIAGNOSIS SYSTEM (TCM)

< SYSTEM DESCRIPTION >

[5AT: RE5R05A]

If there is a malfunction, the lamp lights up for the time corresponding to the suspect circuit.

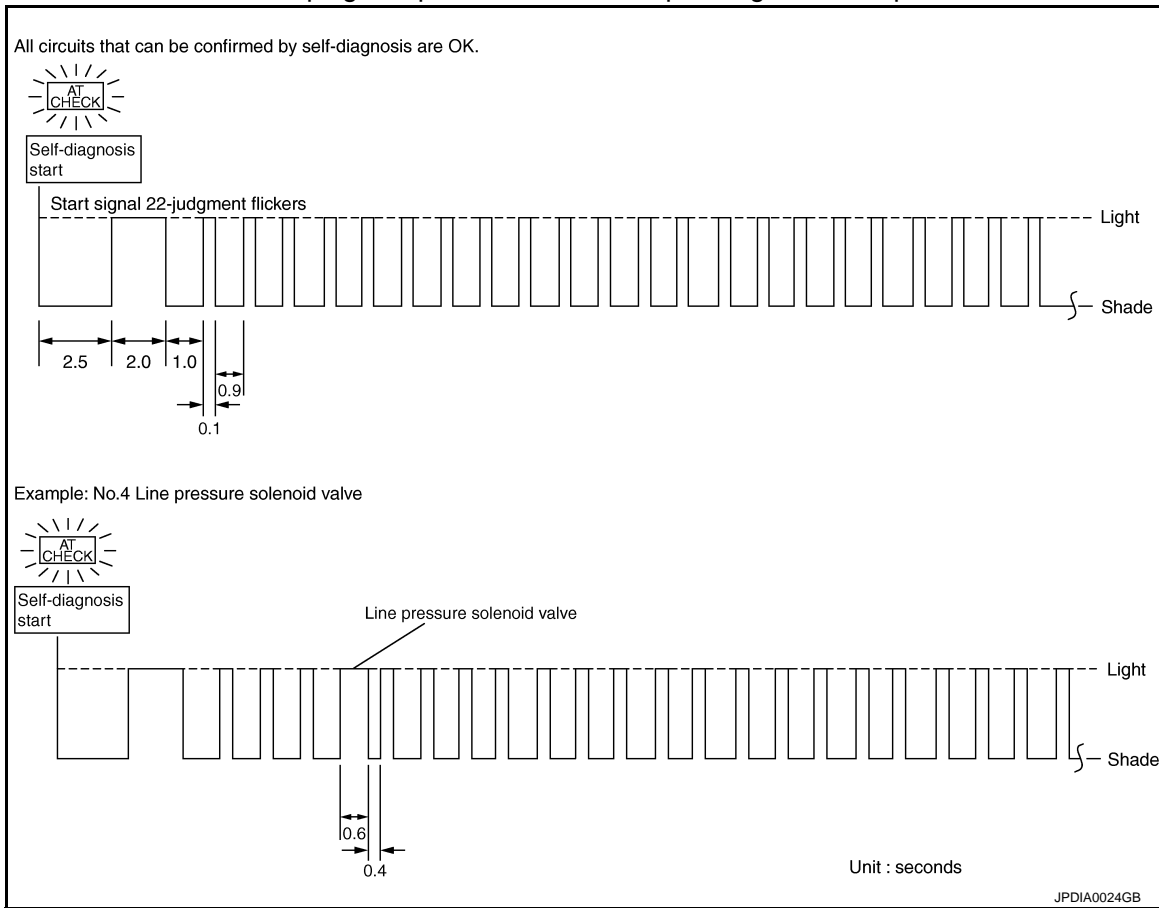

No.	Malfunctioning item	No.	Malfunctioning item
1	Output speed sensor TM-52	12	Interlock TM-75
2	Direct clutch solenoid TM-79	13	1st engine braking TM-76
3	Torque converter TM-67, TM-68	14	Starter relay TM-46
4	Line pressure solenoid TM-69	15	Accelerator pedal position sensor TM-70
5	Input clutch solenoid TM-77	16	Engine speed TM-55
6	Front brake solenoid TM-78	17	CAN communication line TM-45
7	Low coast brake solenoid valve TM-81, TM-82	18	1GR incorrect ratio TM-57
8	High and low reverse clutch solenoid TM-80	19	2GR incorrect ratio TM-59
9	Transmission range switch TM-49	20	3GR incorrect ratio TM-61
10	A/T fluid temperature sensor TM-71	21	4GR incorrect ratio TM-63
11	Input speed sensor TM-51	22	5GR incorrect ratio TM-65

Erase Self-diagnosis

In order to make it easier to find the cause of hard-to-duplicate malfunctions, malfunction information is stored into the control unit as necessary during use by the user. This memory is not erased no matter how many times the ignition switch is turned ON and OFF.

However, this information is erased by turning ignition switch OFF after performing self-diagnostics or by erasing the memory using the CONSULT-III.

CONSULT-III Function (TRANSMISSION)

INFOID:000000004342879

CONSULT-III APPLICATION ITEMS

DIAGNOSIS SYSTEM (TCM)

< SYSTEM DESCRIPTION >

[5AT: RE5R05A]

Diagnostic test mode	Function
Self Diagnostic Results	Retrieve DTC from ECU and display diagnostic items.
Data Monitor	Monitor the input/output signal of the control unit in real time.
CAN Diagnosis	This mode displays a network diagnosis result about CAN by a diagram.
CAN Diagnostic Support Monitor	It monitors the status of CAN communication.
DTC & SRT confirmation	The status of system monitoring tests and the self-diagnosis status/result can be confirmed.
ECU Identification	Display the ECU identification number (part number etc.) of the selected system.
Function Test*	This mode can show results of self-diagnosis of ECU with either "OK" or "NG". For engine, more practical tests regarding sensors/switches and/or actuators are available.

*: Although "Function Test" is selectable, do not use its.

SELF DIAGNOSTIC RESULTS

Refer to [TM-110. "DTC Index"](#).

DATA MONITOR

X: Standard, —: Not applicable, ▼: Option

Monitored item (Unit)	Monitor Item Selection			Remarks
	ECU IN- PUT SIG- NALS	MAIN SIG- NALS	SELEC- TION FROM ITEM	
VHCL/S SE-A/T (km/h or mph)	X	X	▼	Output speed sensor
VHCL/S SE-MTR (km/h or mph)	X	—	▼	—
ACCELE POSI (0.0/8)	X	—	▼	Accelerator pedal position signal
THROTTLE POSI (0.0/8)	X	X	▼	Degree of opening for accelerator recognized by the TCM. For fail-safe operation, the specific value used for control is displayed.
CLSD THL POS (On/Off)	X	—	▼	Signal input with CAN communications.
W/O THL POS (On/Off)	X	—	▼	
GEAR	—	X	▼	Gear position recognized by the TCM updated after gear-shifting.
ENGINE SPEED (rpm)	X	X	▼	—
INPUT SPEED (rpm)	X	X	▼	—
OUTPUT REV (rpm)	X	X	▼	—
GEAR RATIO	—	X	▼	—
TC SLIP SPEED (rpm)	—	X	▼	Difference between engine speed and torque converter input shaft speed.
F SUN GR REV (rpm)	—	—	▼	—
F CARR GR REV (rpm)	—	—	▼	—
ATF TEMP SE 1 (V)	X	—	▼	—
ATF TEMP SE 2 (V)	X	—	▼	—
ATF TEMP 1 (°C or °F)	—	X	▼	Temperature of A/T fluid in the oil pan.
ATF TEMP 2 (°C or °F)	—	X	▼	Temperature of A/T fluid at the exit of torque converter.
BATTERY VOLT (V)	X	—	▼	—

DIAGNOSIS SYSTEM (TCM)

< SYSTEM DESCRIPTION >

[5AT: RE5R05A]

Monitored item (Unit)	Monitor Item Selection			Remarks
	ECU INPUT SIGNALS	MAIN SIGNALS	SELECTION FROM ITEM	
ATF PRES SW 1 (On/Off)	X	X	▼	—
ATF PRES SW 2 (On/Off)	X	X	▼	(For LC/B solenoid)
ATF PRES SW 3 (On/Off)	X	X	▼	—
ATF PRES SW 5 (On/Off)	X	X	▼	—
ATF PRES SW 6 (On/Off)	X	X	▼	—
RANGE SW 1 (On/Off)	X	—	▼	—
RANGE SW 2 (On/Off)	X	—	▼	—
RANGE SW 3 (On/Off)	X	—	▼	—
RANGE SW 4 (On/Off)	X	—	▼	—
SLCT LVR POSI	—	X	▼	Selector lever position is recognized by the TCM. For fail-safe operation, the specific value used for control is displayed.
MANU MODE SW (On/Off)	X	—	▼	—
NON M-MODE SW (On/Off)	X	—	▼	—
UP SW LEVER (On/Off)	X	—	▼	—
DOWN SW LEVER (On/Off)	X	—	▼	—
SFT UP ST SW (On/Off)	—	—	▼	Not mounted but displayed.
SFT DWN ST SW (On/Off)	—	—	▼	
ABS SIGNAL (On/Off)	—	—	▼	—
ACC OD CUT (On/Off)	—	—	▼	Intelligent cruise control (ICC) system.
ACC SIGNAL (On/Off)	—	—	▼	
TCS GR/P KEEP (On/Off)	—	—	▼	—
TCS SIGNAL 2 (On/Off)	—	—	▼	—
TCS SIGNAL 1 (On/Off)	—	—	▼	—
TCC SOLENOID (A)	—	X	▼	—
LINE PRES SOL (A)	—	X	▼	—
I/C SOLENOID (A)	—	X	▼	—
FR/B SOLENOID (A)	—	X	▼	—
D/C SOLENOID (A)	—	X	▼	—
HLR/C SOL (A)	—	X	▼	—
ON OFF SOL (On/Off)	—	—	▼	LC/B solenoid
TCC SOL MON (A)	—	—	▼	—
L/P SOL MON (A)	—	—	▼	—
I/C SOL MON (A)	—	—	▼	—
FR/B SOL MON (A)	—	—	▼	—
D/C SOL MON (A)	—	—	▼	—

DIAGNOSIS SYSTEM (TCM)

< SYSTEM DESCRIPTION >

[5AT: RE5R05A]

Monitored item (Unit)	Monitor Item Selection			Remarks	
	ECU IN-PUT SIG-NALS	MAIN SIG-NALS	SELEC-TION FROM ITEM		
HLR/C SOL MON (A)	—	—	▼	—	A
ON OFF SOL MON (On/Off)	—	—	▼	LC/B solenoid	B
P POSI IND (On/Off)	—	—	▼	—	C
R POSI IND (On/Off)	—	—	▼	—	TM
N POSI IND (On/Off)	—	—	▼	—	
D POSI IND (On/Off)	—	—	▼	—	
4TH POSI IND (On/Off)	—	—	▼	—	E
3RD POSI IND (On/Off)	—	—	▼	—	
2ND POSI IND (On/Off)	—	—	▼	—	F
1ST POSI IND (On/Off)	—	—	▼	—	
MANU MODE IND (On/Off)	—	—	▼	—	G
POWER M LAMP (On/Off)	—	—	▼	Not mounted but displayed.	
F-SAFE IND/L (On/Off)	—	—	▼	—	H
ATF WARN LAMP (On/Off)	—	—	▼	Not mounted but displayed.	
BACK-UP LAMP (On/Off)	—	—	▼	—	I
STARTER RELAY (On/Off)	—	—	▼	—	
RANGE SW 3M (On/Off)	—	—	▼	—	J
C/V CLB ID1	—	—	▼	—	
C/V CLB ID2	—	—	▼	—	K
C/V CLB ID3	—	—	▼	—	
UNIT CLB ID1	—	—	▼	—	
UNIT CLB ID2	—	—	▼	—	L
UNIT CLB ID3	—	—	▼	—	
TRGT GR RATIO	—	—	▼	—	M
TRGT PRES TCC (kPa, kg/cm ² or psi)	—	—	▼	—	
TRGT PRES L/P (kPa, kg/cm ² or psi)	—	—	▼	—	N
TRGT PRES I/C (kPa, kg/cm ² or psi)	—	—	▼	—	
TRGT PRE FR/B (kPa, kg/cm ² or psi)	—	—	▼	—	O
TRGT PRES D/C (kPa, kg/cm ² or psi)	—	—	▼	—	
TRG PRE HLR/C (kPa, kg/cm ² or psi)	—	—	▼	—	P
SHIFT PATTERN	—	—	▼	—	
DRV CST JUDGE	—	—	▼	—	
START RLY MON	—	—	▼	—	
NEXT GR POSI	—	—	▼	—	
SHIFT MODE	—	—	▼	—	

DIAGNOSIS SYSTEM (TCM)

< SYSTEM DESCRIPTION >

[5AT: RE5R05A]

Monitored item (Unit)	Monitor Item Selection			Remarks
	ECU IN-PUT SIG-NALS	MAIN SIG-NALS	SELEC-TION FROM ITEM	
MANU GR POSI	—	—	▼	—
VEHICLE SPEED (km/h or mph)	—	X	▼	Vehicle speed recognized by the TCM.
1 POSITION SW (On/Off)	X	—	▼	Not mounted but displayed.
OD CONT SW (On/Off)	X	—	▼	
HOLD SW (On/Off)	X	—	▼	
BRAKESW (On/Off)	X	—	▼	Stop lamp switch
POWERSHIFT SW (On/Off)	X	—	▼	Not mounted but displayed.
ASCD-OD CUT (On/Off)	—	—	▼	—
ASCD-CRUISE (On/Off)	—	—	▼	—
DS RANGE (On/Off)	X	—	▼	—

DTC & SRT CONFIRMATION

Operation Procedure

1. Touch "DTC & SRT confirmation" in "TRANSMISSION".
2. Touch select item menu.
3. Touch "START".
4. Perform driving test according to "DTC CONFIRMATION PROCEDURE" in "COMPONENT DIAGNOSIS FOR DTC".
 - When testing conditions are satisfied, CONSULT-III screen changes from "OUT OF CONDITION" to "TESTING".
5. Stop the vehicle.
 - If "NG" appears on the screen, malfunction may exit.
6. Perform test drive to check gear shift feeling in accordance with instructions displayed.
7. Touch "YES" or "NO".
8. CONSULT-III procedure is ended.
 - If "NG" appears on the screen, malfunction may exit.

Item name	Description	Check item
1ST GR FNCTN P0731	Following items for "1GR function ratio" can be confirmed. <ul style="list-style-type: none"> • Self-diagnosis status (whether the diagnosis is being performed or not) • Self-diagnostic results (OK or NG) 	<ul style="list-style-type: none"> • Input clutch solenoid valve • Front brake solenoid valve • Direct clutch solenoid valve • High and low reverse clutch solenoid valve • Each clutch and brake • Hydraulic control circuit
2ND GR FNCTN P0732	Following items for "2GR function ratio" can be confirmed. <ul style="list-style-type: none"> • Self-diagnosis status (whether the diagnosis is being performed or not) • Self-diagnostic results (OK or NG) 	
3RD GR FNCTN P0733	Following items for "3GR function ratio" can be confirmed. <ul style="list-style-type: none"> • Self-diagnosis status (whether the diagnosis is being performed or not) • Self-diagnostic results (OK or NG) 	
4TH GR FNCTN P0734	Following items for "4GR function ratio" can be confirmed. <ul style="list-style-type: none"> • Self-diagnosis status (whether the diagnosis is being performed or not) • Self-diagnostic results (OK or NG) 	
5TH GR FNCTN P0735	Following items for "5GR function ratio" can be confirmed. <ul style="list-style-type: none"> • Self-diagnosis status (whether the diagnosis is being performed or not) • Self-diagnostic results (OK or NG) 	

U1000 CAN COMM CIRCUIT

< DTC/CIRCUIT DIAGNOSIS >

[5AT: RE5R05A]

DTC/CIRCUIT DIAGNOSIS

U1000 CAN COMM CIRCUIT

Description

INFOID:000000004342880

CAN (Controller Area Network) is a serial communication line for real-time application. It is an on-vehicle multiplex communication line with high data communication speed and excellent malfunction detection ability. Many electronic control units are equipped onto a vehicle, and each control unit shares information and links with other control units during operation (not independently). In CAN communication, control units are connected with 2 communication lines (CAN-H line, CAN-L line) allowing a high rate of information transmission with less wiring. Each control unit transmits/receives data but selectively reads required data only.

DTC Logic

INFOID:000000004342881

DTC DETECTION LOGIC

DTC	Item (CONSULT-III screen terms)	A/T CHECK indicator lamp judgment flicker	Diagnostic item is de- tected when...	Possible cause
U1000	CAN COMM CIRCUIT	17th	TCM is not transmitting or receiving CAN com- munication signal for 2 seconds or more.	<ul style="list-style-type: none">• Harness or connectors (CAN communication line is open or short- ed.)• TCM

DTC CONFIRMATION PROCEDURE

NOTE:

If "DTC CONFIRMATION PROCEDURE" has been previously performed, always turn ignition switch OFF. Then wait at least 10 seconds before performing the next test.

1. CHECK DTC DETECTION

With CONSULT-III

1. Start the engine.
2. Run engine for at least 6 consecutive seconds at idle speed.
3. Perform "Self Diagnostic Results" in "TRANSMISSION".

With GST

Follow the procedure "With CONSULT-III"

Is "U1000" detected?

YES >> Go to [TM-45. "Diagnosis Procedure"](#).

NO >> Check intermittent incident. Refer to [GI-40. "Intermittent Incident"](#).

Diagnosis Procedure

INFOID:000000004342882

Go to [LAN-17. "Trouble Diagnosis Flow Chart"](#).

P0615 STARTER RELAY

< DTC/CIRCUIT DIAGNOSIS >

[5AT: RE5R05A]

P0615 STARTER RELAY

Description

INFOID:000000004342883

TCM prohibits cranking other than at "P" or "N" position.

DTC Logic

INFOID:000000004342884

DTC DETECTION LOGIC

DTC	Item (CONSULT-III screen terms)	A/T CHECK indicator lamp judgment flicker	Diagnostic item is detected when...	Possible cause
P0615	STARTER RELAY	14th	If this signal is ON other than in "P" or "N" position, this is judged to be a malfunction. (And if it is OFF in "P" or "N" position, this too is judged to be a malfunction.)	<ul style="list-style-type: none"> • Harness or connectors (Starter relay and TCM circuit is open or shorted.) • Starter relay circuit

DTC CONFIRMATION PROCEDURE

NOTE:

If "DTC CONFIRMATION PROCEDURE" has been previously performed, always turn ignition switch OFF. Then wait at least 10 seconds before performing the next test.

1. CHECK DTC DETECTION

Ⓟ With CONSULT-III

1. Shift the selector lever in "P" or "N" position.
2. Turn ignition switch ON and wait for at least 2 seconds.
3. Perform "Self Diagnostic Results" in "TRANSMISSION".

Is "P0615" detected?

YES >> Go to [TM-46, "Diagnosis Procedure"](#).

NO >> Check intermittent incident. Refer to [GI-40, "Intermittent Incident"](#).

Diagnosis Procedure

INFOID:000000004342885

1. CHECK STARTER RELAY SIGNAL

1. Turn ignition switch ON.
2. Check voltage between IPDM E/R connector terminal and ground.

IPDM E/R connector		Ground	Condition	Voltage (Approx.)
Connector	Terminal			
E5	30	Ground	Selector lever in "P" and "N" positions.	Battery voltage
			Selector lever in other positions.	0 V

Is the inspection result normal?

YES >> Check starter relay circuit. Refer to [STR-9, "Wiring Diagram - STARTING SYSTEM -"](#).

NO >> GO TO 2.

2. CHECK HARNESS BETWEEN A/T ASSEMBLY AND IPDM E/R (PART 1)

1. Turn ignition switch OFF.
2. Disconnect A/T assembly connector and IPDM E/R connector.
3. Check continuity between A/T assembly vehicle side harness connector terminal and IPDM E/R vehicle side harness connector terminal.

P0615 STARTER RELAY

< DTC/CIRCUIT DIAGNOSIS >

[5AT: RE5R05A]

A/T assembly vehicle side harness connector		IPDM E/R vehicle side harness connector		Continuity
Connector	Terminal	Connector	Terminal	
F51	9	E5	30	Existed

Is the inspection result normal?

YES >> GO TO 3.

NO >> Repair or replace damaged parts.

3. CHECK HARNESS BETWEEN A/T ASSEMBLY AND IPDM E/R (PART 2)

Check continuity between A/T assembly vehicle side harness connector terminal and ground.

A/T assembly vehicle side harness connector		Ground	Continuity
Connector	Terminal		
F51	9		Not existed

Is the inspection result normal?

YES >> GO TO 4.

NO >> Repair or replace damaged parts.

4. DETECT MALFUNCTIONING ITEM (PART 1)

Check the following.

- Check terminals of A/T assembly connector and IPDM E/R connector for damage.
- Check connector for loose connection.

Is the inspection result normal?

YES >> GO TO 5.

NO >> Repair or replace damaged parts.

5. CHECK TERMINAL CORD ASSEMBLY

1. Remove control valve with TCM. Refer to [TM-165, "Exploded View"](#).
2. Disconnect TCM connector.
3. Check continuity between A/T assembly harness connector terminal and TCM connector terminal.

A/T assembly harness connector		TCM connector		Continuity
Connector	Terminal	Connector	Terminal	
F51	9	F151	8	Existed

Is the inspection result normal?

YES >> GO TO 6.

NO >> Repair or replace damaged parts.

6. DETECT MALFUNCTIONING ITEM (PART 2)

Check the following.

- Check terminals of TCM connector and harness cladding for damage.
- Check connector for loose connection.

Is the inspection result normal?

YES >> Replace the control valve with TCM. Refer to [TM-165, "Exploded View"](#)

NO >> Repair or replace damaged parts.

P0700 TRANSMISSION CONTROL

< DTC/CIRCUIT DIAGNOSIS >

[5AT: RE5R05A]

P0700 TRANSMISSION CONTROL

Description

INFOID:000000004342886

The TCM consists of a microcomputer and connectors for signal input and output and for power supply. The TCM controls the A/T.

DTC Logic

INFOID:000000004342887

DTC DETECTION LOGIC

DTC	Item (CONSULT-III screen terms)	A/T CHECK indicator lamp judgment flicker	Diagnostic item is detect- ed when...	Possible cause
P0700	TRANSMISSION CON- TROL	—	TCM is malfunctioning.	TCM

DTC CONFIRMATION PROCEDURE

NOTE:

If “DTC CONFIRMATION PROCEDURE” has been previously performed, always turn ignition switch OFF. Then wait at least 10 seconds before performing the next test.

1. CHECK DTC DETECTION

④ With CONSULT-III

1. Start the engine.
2. Run engine for at least 2 consecutive seconds at idle speed.
3. Perform “Self Diagnostic Results” in “TRANSMISSION”.

④ With GST

Follow the procedure “With CONSULT-III”.

Is “P0700” detected?

- YES >> Go to [TM-48, "Diagnosis Procedure"](#).
- NO >> Check intermittent incident. Refer to [GI-40, "Intermittent Incident"](#).

Diagnosis Procedure

INFOID:000000004342888

1. CHECK DTC

④ With CONSULT-III

1. Turn ignition switch ON.
2. Perform “Self Diagnostic Results” in “TRANSMISSION”.
3. Touch “Erase”.
4. Turn ignition switch OFF and wait for at least 10 seconds.
5. Check the DTC again. Refer to [TM-48, "DTC Logic"](#)

Is “P0700” detected again?

- YES >> Replace the control valve with TCM. Refer to [TM-165, "Exploded View"](#).
- NO >> Check intermittent incident. Refer to [GI-40, "Intermittent Incident"](#).

P0705 TRANSMISSION RANGE SWITCH A

< DTC/CIRCUIT DIAGNOSIS >

[5AT: RE5R05A]

P0705 TRANSMISSION RANGE SWITCH A

Description

INFOID:000000004342889

The transmission range switch detects the selector lever position and transmits a signal to the TCM.

DTC Logic

INFOID:000000004342890

DTC DETECTION LOGIC

DTC	Item (CONSULT-III screen terms)	A/T CHECK indicator lamp judgment flicker	Diagnostic item is de- tected when...	Possible cause
P0705	T/M RANGE SWITCH A	9th	<ul style="list-style-type: none">Transmission range switch 1 – 4 signals input with impossible pattern.“P” position is detected from “N” position without any other position being detected in between.	<ul style="list-style-type: none">Harness or connectors (Transmission range switches 1, 2, 3, 4 and TCM circuit is open or shorted.)Transmission range switches 1, 2, 3 and 4

DTC CONFIRMATION PROCEDURE

CAUTION:

Always drive vehicle at a safe speed.

NOTE:

If “DTC CONFIRMATION PROCEDURE” has been previously performed, always turn ignition switch OFF. Then wait at least 10 seconds before performing the next test.

1. CHECK DTC DETECTION

With CONSULT-III

- Start the engine.
- Select “Data Monitor” in “TRANSMISSION”.
- Drive vehicle and maintain the following conditions for least 2 consecutive seconds.

ACCELE POSI : More than 1.0/8

With GST

Follow the procedure “With CONSULT-III”.

Is “P0705” detected?

YES >> Go to [TM-49, "Diagnosis Procedure"](#).

NO >> Check intermittent incident. Refer to [GI-40, "Intermittent Incident"](#).

Diagnosis Procedure

INFOID:000000004342891

1. CHECK TCM POWER SUPPLY AND GROUND CIRCUIT

Check TCM power supply and ground circuit. Refer to [TM-88, "Diagnosis Procedure"](#).

Is the inspection result normal?

YES >> GO TO 2.

NO >> Repair or replace damaged parts.

2. CHECK SUB-HARNESS

- Remove control valve with TCM. Refer to [TM-165, "Exploded View"](#).
- Disconnect transmission range switch connector and TCM connector.
- Check continuity between transmission range switch connector terminals and TCM connector terminals.

P0705 TRANSMISSION RANGE SWITCH A

< DTC/CIRCUIT DIAGNOSIS >

[5AT: RE5R05A]

Transmission range switch connector		TCM connector		Continuity
Connector	Terminal	Connector	Terminal	
F154	1	F152	13	Existed
	2		11	
	3		12	
	5		14	

Is the inspection result normal?

YES >> GO TO 3.

NO >> Repair or replace damaged parts.

3.DETECT MALFUNCTIONING ITEM

Check the following.

- Check terminals of transmission range switch connector and TCM connector, and harness cladding for damage.
- Check connector for loose connection.

Is the inspection result normal?

YES >> Replace the control valve with TCM. Refer to [TM-165. "Exploded View"](#).

NO >> Repair or replace damaged parts.

P0717 INPUT SPEED SENSOR A

< DTC/CIRCUIT DIAGNOSIS >

[5AT: RE5R05A]

P0717 INPUT SPEED SENSOR A

Description

INFOID:000000004342892

The input speed sensor detects input shaft rpm (revolutions per minute). It is located on the input side of the A/T. Monitors revolution of sensor 1 and sensor 2 for non-standard conditions.

DTC Logic

INFOID:000000004342893

DTC DETECTION LOGIC

DTC	Item (CONSULT-III screen terms)	A/T CHECK indicator lamp judgment flicker	Diagnostic item is detected when...	Possible cause
P0717	INPUT SPEED SENSOR A	11th	<ul style="list-style-type: none"> TCM does not receive the proper voltage signal from the sensor. TCM detects an irregularity only at position of 4GR for input speed sensor 2. 	<ul style="list-style-type: none"> Harness or connectors (Sensor circuit is open or shorted.) Input speed sensor 1 and/or 2

DTC CONFIRMATION PROCEDURE

CAUTION:

Always drive vehicle at a safe speed.

NOTE:

If "DTC CONFIRMATION PROCEDURE" has been previously performed, always turn ignition switch OFF. Then wait at least 10 seconds before performing the next test.

1. CHECK DTC DETECTION

With CONSULT-III

- Start the engine.
- Select "Data Monitor" in "TRANSMISSION".
- Drive vehicle and maintain the following conditions for at least 5 consecutive seconds.

VHCL/S SE-A/T : 40 km/h (25 MPH) or more

ACCELE POSI : More than 0.5/8

ENGINE SPEED : 1,500 rpm or more

SLCT LVR POSI : "D" position

GEAR (Input speed sensor 1) : "4" or "5" position

GEAR (Input speed sensor 2) : All positions

Driving location : Driving the vehicle uphill (increased engine load) will help maintain the driving conditions required for this test.

With GST

Follow the procedure "With CONSULT-III".

Is "P0717" detected?

YES >> Go to [TM-51, "Diagnosis Procedure"](#).

NO >> Check intermittent incident. Refer to [GI-40, "Intermittent Incident"](#).

Diagnosis Procedure

INFOID:000000004342894

1. CHECK TCM POWER SUPPLY AND GROUND CIRCUIT

Check TCM power supply and ground circuit. Refer to [TM-88, "Diagnosis Procedure"](#).

Is the inspection result normal?

YES >> Replace the control valve with TCM. Refer to [TM-165, "Exploded View"](#).

NO >> Repair or replace damaged parts.

P0720 OUTPUT SPEED SENSOR

< DTC/CIRCUIT DIAGNOSIS >

[5AT: RE5R05A]

P0720 OUTPUT SPEED SENSOR

Description

INFOID:000000004342895

The output speed sensor detects the revolution of the parking gear and emits a pulse signal. The pulse signal is transmitted to the TCM which converts it into vehicle speed.

DTC Logic

INFOID:000000004342896

DTC DETECTION LOGIC

DTC	Item (CONSULT-III screen terms)	A/T CHECK indicator lamp judgment flicker	Diagnostic item is de- tected when...	Possible cause
P0720	OUTPUT SPEED SEN- SOR	1st	<ul style="list-style-type: none">• Signal from output speed sensor not input due to cut line or the like.• Unexpected signal input during running.• After ignition switch is turned ON, unexpected signal input from vehicle speed signal before the vehicle starts moving.	<ul style="list-style-type: none">• Harness or connectors (Sensor circuit is open or shorted.)• Output speed sensor• Vehicle speed signal

DTC CONFIRMATION PROCEDURE

CAUTION:

- Always drive vehicle at a safe speed.
- Be careful not to rev engine into the red zone on the tachometer.

NOTE:

If "DTC CONFIRMATION PROCEDURE" has been previously performed, always turn ignition switch OFF. Then wait at least 10 seconds before performing the next test.

1. CHECK OUTPUT SPEED SENSOR AND VEHICLE SPEED SIGNAL

With CONSULT-III

1. Start the engine.
2. Select "Data Monitor" in "TRANSMISSION".
3. Drive vehicle and check for an increase of "VHCL/S SE-A/T" value in response to "VHCL/S SE-MTR" value.

VHCL/S SE-A/T : Approximately matches the speedometer reading.

VHCL/S SE-MTR : Approximately matches the speedometer reading.

Are "VHCL/S SE-A/T" and "VHCL/S SE-MTR" values correct?

YES >> GO TO 2.

NO >> Go to [TM-53, "Diagnosis Procedure"](#).

2. CHECK DTC DETECTION 1

With CONSULT-III

1. Select "Data Monitor" in "TRANSMISSION".
2. Drive vehicle and maintain the following conditions for at least 5 consecutive seconds.

VHCL/S SE-A/T : 30 km/h (19 MPH) or more

ACCELE POSI : More than 1.0/8

SLCT LVR POSI : "D" position

Drive location : Driving the vehicle uphill (increased engine load) will help maintain the driving conditions required for this test.

With GST

Follow the procedure "With CONSULT-III".

P0720 OUTPUT SPEED SENSOR

< DTC/CIRCUIT DIAGNOSIS >

[5AT: RE5R05A]

Is "P0720" detected?

- YES >> Go to [TM-53, "Diagnosis Procedure"](#).
- NO >> GO TO 3.

3.CHECK DTC DETECTION 2

With CONSULT-III

1. Select "Data Monitor" in "TRANSMISSION".
2. Drive vehicle and maintain the following conditions for at least 5 consecutive seconds.

- ACCELE POSI** : More than 1.0/8
- ENGINE SPEED** : 3,500 rpm or more
- SLCT LVR POSI** : "D" position
- Drive location** : Driving the vehicle uphill (increased engine load) will help maintain the driving conditions required for this test.

With GST

Follow the procedure "With CONSULT-III".

Is "P0720" detected?

- YES >> Go to [TM-53, "Diagnosis Procedure"](#).
- NO >> Check intermittent incident. Refer to [GI-40, "Intermittent Incident"](#).

Diagnosis Procedure

INFOID:000000004342897

1.CHECK TCM POWER SUPPLY AND GROUND CIRCUIT

Check TCM power supply and ground circuit. Refer to [TM-88, "Diagnosis Procedure"](#).

Is the inspection result normal?

- YES >> GO TO 2.
- NO >> Repair or replace damaged parts.

2.CHECK SUB-HARNESS

1. Remove control valve with TCM. Refer to [TM-165, "Exploded View"](#).
2. Disconnect transmission range switch connector and TCM connector.
3. Check continuity between transmission range switch connector terminals and TCM connector terminals.

Transmission range switch connector		TCM connector		Continuity
Connector	Terminal	Connector	Terminal	
F154	8	F152	20	Existed
	9		17	
	10		16	

Is the inspection result normal?

- YES >> GO TO 3.
- NO >> Repair or replace damaged parts.

3.DETECT MALFUNCTIONING ITEM

Check the following.

- Check terminals of transmission range switch connector and TCM connector, and harness cladding for damage.
- Check connector for loose connection.

Is the inspection result normal?

- YES >> GO TO 4.
- NO >> Repair or replace damaged parts.

4.REPLACE THE OUTPUT SPEED SENSOR AND CHECK DTC

1. Replace the output speed sensor. Refer to [TM-183, "2WD : Exploded View"](#) (2WD) or [TM-201, "Exploded View"](#), [TM-211, "Disassembly"](#) (AWD).
2. Reinstall any parts removed.
3. Perform "DTC CONFIRMATION PROCEDURE". Refer to [TM-52, "DTC Logic"](#).

P0720 OUTPUT SPEED SENSOR

< DTC/CIRCUIT DIAGNOSIS >

[5AT: RE5R05A]

Is the inspection result normal?

YES >> INSPECTION END

NO >> Replace the control valve with TCM. Refer to [TM-165. "Exploded View"](#).

P0725 ENGINE SPEED

< DTC/CIRCUIT DIAGNOSIS >

[5AT: RE5R05A]

P0725 ENGINE SPEED

Description

INFOID:000000004342898

The engine speed signal is transmitted from the ECM to the TCM with CAN communication line.

DTC Logic

INFOID:000000004342899

DTC DETECTION LOGIC

DTC	Item (CONSULT-III screen terms)	A/T CHECK indicator lamp judgment flicker	Diagnostic item is detected when...	Possible cause
P0725	ENGINE SPEED	16th	TCM does not receive the CAN communication signal from the ECM.	Harness or connectors (ECM to TCM circuit is open or shorted.)

DTC CONFIRMATION PROCEDURE

CAUTION:

Always drive vehicle at a safe speed.

NOTE:

If "DTC CONFIRMATION PROCEDURE" has been previously performed, always turn ignition switch OFF. Then wait at least 10 seconds before performing the next test.

1. CHECK DTC DETECTION

With CONSULT-III

- Start the engine.
- Select "Data Monitor" in "TRANSMISSION".
- Drive vehicle and maintain the following conditions for at least 10 consecutive seconds.

VHCL/S SE-A/T : 10 km/h (6 MPH) or more

ACCELE POSI : More than 1.0/8

SLCT LVR POSI : "D" position

Is "P0725" detected?

YES >> Go to [TM-55, "Diagnosis Procedure"](#).

NO >> Check intermittent incident. Refer to [GI-40, "Intermittent Incident"](#).

Diagnosis Procedure

INFOID:000000004342900

1. CHECK DTC OF ECM

With CONSULT-III

- Turn ignition switch ON.
- Perform "Self Diagnostic Results" in "ENGINE".

Is the inspection result normal?

YES >> GO TO 2.

NO >> Check DTC detected item. Refer to [EC-534, "DTC Index"](#).

2. CHECK DTC OF TCM

With CONSULT-III

Perform "Self Diagnostic Results" in "TRANSMISSION".

Is any DTC other than "P0725" detected?

YES >> Check DTC detected item. Refer to [TM-110, "DTC Index"](#).

NO >> GO TO 3.

3. CHECK THE IGNITION SIGNAL CIRCUIT

With CONSULT-III

- Start the engine.
- Select "Data Monitor" in "TRANSMISSION".

P0725 ENGINE SPEED

< DTC/CIRCUIT DIAGNOSIS >

[5AT: RE5R05A]

3. Check for engine speed change corresponding to "ACCELE POSI" while monitoring "ENGINE SPEED".

Item name	Condition	Value
ENGINE SPEED	Engine running	Closely matches the tachometer reading.
ACCELE POSI	Released accelerator pedal.	0.0/8
	Fully depressed accelerator pedal	8.0/8

Is the inspection result normal?

YES >> GO TO 4.

NO >> Check ignition signal circuit. Refer to [EC-476, "Description"](#).

4. CHECK TCM POWER SUPPLY AND GROUND CIRCUIT

Check TCM power supply and ground circuit. Refer to [TM-88, "Diagnosis Procedure"](#).

Is the inspection result normal?

YES >> Replace the control valve with TCM. Refer to [TM-165, "Exploded View"](#).

NO >> Repair or replace damaged parts.

P0731 1GR INCORRECT RATIO

< DTC/CIRCUIT DIAGNOSIS >

[5AT: RE5R05A]

P0731 1GR INCORRECT RATIO

Description

INFOID:000000004342901

This malfunction is detected when the A/T does not shift into 1GR position as instructed by TCM. This is not only caused by electrical malfunction (circuits open or shorted) but by mechanical malfunction such as control valve sticking, improper solenoid valve operation, etc.

DTC Logic

INFOID:000000004342902

DTC DETECTION LOGIC

DTC	Item (CONSULT-III screen terms)	A/T CHECK indicator lamp judgment flicker	Diagnostic item is de- tected when...	Possible cause
P0731	1GR INCORRECT RA- TIO	18th	TCM detects any incon- sistency in the actual gear ratio.	<ul style="list-style-type: none"> • Input clutch solenoid valve • Front brake solenoid valve • Direct clutch solenoid valve • High and low reverse clutch solenoid valve • Each clutch and brake • Hydraulic control circuit

DTC CONFIRMATION PROCEDURE

CAUTION:

Always drive vehicle at a safe speed.

NOTE:

If "DTC CONFIRMATION PROCEDURE" has been previously performed, always turn ignition switch OFF. Then wait at least 10 seconds before performing the next test.

1. CHECK ATF TEMPERATURE

With CONSULT-III

1. Start the engine.
2. Select "Data Monitor" in "TRANSMISSION".
3. Check ATF temperature is in the following range.

ATF TEMP 1 : 20°C (68°F) – 140°C (284°F)

With GST

1. Start the engine.
2. Drive vehicle for approximately 5 minutes in urban areas, GO TO 2.

Is ATF temperature within specified range?

YES >> GO TO 2.

NO >> Drive vehicle to warm ATF or stop engine to cool ATF.

2. CHECK SYMPTOM 1

With CONSULT-III

1. Select "DTC & SRT confirmation" in "TRANSMISSION".
2. Select "1ST GR FNCTN P0731".
3. Drive vehicle and maintain the following conditions.

MANU MODE SW : ON

GEAR : "1" position

ACCELE POSI : 0.6/8 or more

VEHICLE SPEED : 10 km/h (6 MPH) or more

P0731 1GR INCORRECT RATIO

< DTC/CIRCUIT DIAGNOSIS >

[5AT: RE5R05A]

ENGINE SPEED : INPUT SPEED – 50 rpm or more
INPUT SPEED : 300 rpm or more

4. Keep the current driving status for at least 5 consecutive seconds if CONSULT-III screen changes from “OUT OF CONDITION” to “TESTING”.

CAUTION:

When “TESTING” is not indicated on CONSULT-III for a long time, check “Self Diagnostic Results” mode for “TRANSMISSION”. When a DTC other than “P0731” is detected, check the DTC. Refer to [TM-110, "DTC Index"](#).

 **With GST**

1. Drive vehicle and maintain the following conditions for at least 5 consecutive seconds.

Manual mode switch : ON
Gear position : “1” position
Accelerator opening : 0.6/8 or more
Vehicle speed : 10 km/h (6 MPH) or more

2. Check DTC.

Is “STOP VEHICLE” or “COMPLETED RESULT NG” displayed? / Is “P0731” detected?

- YES-1 >> “STOP VEHICLE”: GO TO 3.
YES-2 >> “COMPLETED RESULT NG”: Go to [TM-58, "Diagnosis Procedure"](#).
YES-3 >> “P0731” is detected: Go to [TM-58, "Diagnosis Procedure"](#).
NO >> Check intermittent incident. Refer to [GI-40, "Intermittent Incident"](#).

3. CHECK SYMPTOM 2

 **With CONSULT-III**

1. Stop vehicle.
2. Drive vehicle in “D” position allowing it to shift from 1GR to 5GR and check shift timing and shift shock.

Is the inspection result normal?

- YES >> Check intermittent incident. Refer to [GI-40, "Intermittent Incident"](#).
NO >> Confirm malfunction phenomena by “ROAD TEST” to repair malfunctioning part. Refer to [TM-151, "Description"](#).

Diagnosis Procedure

INFOID:000000004342903

1. CHECK TCM POWER SUPPLY AND GROUND CIRCUIT

Check TCM power supply and ground circuit. Refer to [TM-88, "Diagnosis Procedure"](#).

Is the inspection result normal?

- YES >> GO TO 2.
NO >> Repair or replace damaged parts.

2. REPLACE CONTROL VALVE WITH TCM

1. Replace control valve with TCM. Refer to [TM-165, "Exploded View"](#).
2. Perform “DTC CONFIRMATION PROCEDURE”. Refer to [TM-57, "DTC Logic"](#).

Is the inspection result normal?

- YES >> INSPECTION END
NO >> Confirm malfunction phenomena by “ROAD TEST” to repair malfunctioning part. Refer to [TM-151, "Description"](#).

P0732 2GR INCORRECT RATIO

< DTC/CIRCUIT DIAGNOSIS >

[5AT: RE5R05A]

P0732 2GR INCORRECT RATIO

Description

INFOID:000000004342904

This malfunction is detected when the A/T does not shift into 2GR position as instructed by TCM. This is not only caused by electrical malfunction (circuits open or shorted) but by mechanical malfunction such as control valve sticking, improper solenoid valve operation, etc.

DTC Logic

INFOID:000000004342905

DTC DETECTION LOGIC

DTC	Item (CONSULT-III screen terms)	A/T CHECK indicator lamp judgment flicker	Diagnostic item is de- tected when...	Possible cause
P0732	2GR INCORRECT RA- TIO	19th	TCM detects any incon- sistency in the actual gear ratio.	<ul style="list-style-type: none"> • Input clutch solenoid valve • Front brake solenoid valve • Direct clutch solenoid valve • High and low reverse clutch solenoid valve • Each clutch and brake • Hydraulic control circuit

DTC CONFIRMATION PROCEDURE

CAUTION:

Always drive vehicle at a safe speed.

NOTE:

If "DTC CONFIRMATION PROCEDURE" has been previously performed, always turn ignition switch OFF. Then wait at least 10 seconds before performing the next test.

1. CHECK ATF TEMPERATURE

With CONSULT-III

1. Start the engine.
2. Select "Data Monitor" in "TRANSMISSION".
3. Check ATF temperature is in the following range.

ATF TEMP 1 : 20°C (68°F) – 140°C (284°F)

With GST

1. Start the engine.
2. Drive vehicle for approximately 5 minutes in urban areas, GO TO 2.

Is ATF temperature within specified range?

YES >> GO TO 2.

NO >> Drive vehicle to warm ATF or stop engine to cool ATF.

2. CHECK SYMPTOM 1

With CONSULT-III

1. Select "DTC & SRT confirmation" in "TRANSMISSION".
2. Select "2ND GR FNCTN P0732".
3. Drive vehicle and maintain the following conditions.

MANU MODE SW : ON

GEAR : "2" position

ACCELE POSI : 0.6/8 or more

VEHICLE SPEED : 10 km/h (6 MPH) or more

P0732 2GR INCORRECT RATIO

< DTC/CIRCUIT DIAGNOSIS >

[5AT: RE5R05A]

ENGINE SPEED : INPUT SPEED – 50 rpm or more
INPUT SPEED : 300 rpm or more

4. Keep the current driving status for at least 5 consecutive seconds if CONSULT-III screen changes from “OUT OF CONDITION” to “TESTING”.

CAUTION:

When “TESTING” is not indicated on CONSULT-III for a long time, check “Self Diagnostic Results” mode for “TRANSMISSION”. When a DTC other than “P0732” is detected, check the DTC. Refer to [TM-110, "DTC Index"](#).

 **With GST**

1. Drive vehicle and maintain the following conditions for at least 5 consecutive seconds.

Manual mode switch : ON
Gear position : “2” position
Accelerator opening : 0.6/8 or more
Vehicle speed : 10 km/h (6 MPH) or more

2. Check DTC.

Is “STOP VEHICLE” or “COMPLETED RESULT NG” displayed? / Is “P0732” detected?

- YES-1 >> “STOP VEHICLE”: GO TO 3.
YES-2 >> “COMPLETED RESULT NG”: Go to [TM-60, "Diagnosis Procedure"](#).
YES-3 >> “P0732” is detected: Go to [TM-60, "Diagnosis Procedure"](#).
NO >> Check intermittent incident. Refer to [GI-40, "Intermittent Incident"](#).

3.CHECK SYMPTOM 2

 **With CONSULT-III**

1. Stop vehicle.
2. Drive vehicle in “D” position allowing it to shift from 1GR to 5GR and check shift timing and shift shock.

Is the inspection result normal?

- YES >> Check intermittent incident. Refer to [GI-40, "Intermittent Incident"](#).
NO >> Confirm malfunction phenomena by “ROAD TEST” to repair malfunctioning part. Refer to [TM-151, "Description"](#).

Diagnosis Procedure

INFOID:000000004342906

1.CHECK TCM POWER SUPPLY AND GROUND CIRCUIT

Check TCM power supply and ground circuit. Refer to [TM-88, "Diagnosis Procedure"](#).

Is the inspection result normal?

- YES >> GO TO 2.
NO >> Repair or replace damaged parts.

2.REPLACE CONTROL VALVE WITH TCM

1. Replace control valve with TCM. Refer to [TM-165, "Exploded View"](#).
2. Perform “DTC CONFIRMATION PROCEDURE”. Refer to [TM-59, "DTC Logic"](#).

Is the inspection result normal?

- YES >> INSPECTION END
NO >> Confirm malfunction phenomena by “ROAD TEST” to repair malfunctioning part. Refer to [TM-151, "Description"](#).

P0733 3GR INCORRECT RATIO

< DTC/CIRCUIT DIAGNOSIS >

[5AT: RE5R05A]

P0733 3GR INCORRECT RATIO

Description

INFOID:000000004342907

This malfunction is detected when the A/T does not shift into 3GR position as instructed by TCM. This is not only caused by electrical malfunction (circuits open or shorted) but by mechanical malfunction such as control valve sticking, improper solenoid valve operation, etc.

DTC Logic

INFOID:000000004342908

DTC DETECTION LOGIC

DTC	Item (CONSULT-III screen terms)	A/T CHECK indicator lamp judgment flicker	Diagnostic item is detected when...	Possible cause
P0733	3GR INCORRECT RATIO	20th	TCM detects any inconsistency in the actual gear ratio.	<ul style="list-style-type: none"> Input clutch solenoid valve Front brake solenoid valve Direct clutch solenoid valve High and low reverse clutch solenoid valve Each clutch and brake Hydraulic control circuit

DTC CONFIRMATION PROCEDURE

CAUTION:

Always drive vehicle at a safe speed.

NOTE:

If "DTC CONFIRMATION PROCEDURE" has been previously performed, always turn ignition switch OFF. Then wait at least 10 seconds before performing the next test.

1. CHECK ATF TEMPERATURE

With CONSULT-III

- Start the engine.
- Select "Data Monitor" in "TRANSMISSION".
- Check ATF temperature is in the following range.

ATF TEMP 1 : 20°C (68°F) – 140°C (284°F)

With GST

- Start the engine.
- Drive vehicle for approximately 5 minutes in urban areas, GO TO 2.

Is ATF temperature within specified range?

YES >> GO TO 2.

NO >> Drive vehicle to warm ATF or stop engine to cool ATF.

2. CHECK SYMPTOM 1

With CONSULT-III

- Select "DTC & SRT confirmation" in "TRANSMISSION".
- Select "3RD GR FNCTN P0733".
- Drive vehicle and maintain the following conditions.

MANU MODE SW : ON

GEAR : "3" position

ACCELE POSI : 0.6/8 or more

VEHICLE SPEED : 10 km/h (6 MPH) or more

P0733 3GR INCORRECT RATIO

< DTC/CIRCUIT DIAGNOSIS >

[5AT: RE5R05A]

ENGINE SPEED : INPUT SPEED – 50 rpm or more
INPUT SPEED : 300 rpm or more

4. Keep the current driving status for at least 5 consecutive seconds if CONSULT-III screen changes from “OUT OF CONDITION” to “TESTING”.

CAUTION:

When “TESTING” is not indicated on CONSULT-III for a long time, check “Self Diagnostic Results” mode for “TRANSMISSION”. When a DTC other than “P0733” is detected, check the DTC. Refer to [TM-110, "DTC Index"](#).

 **With GST**

1. Drive vehicle and maintain the following conditions for at least 5 consecutive seconds.

Manual mode switch : ON
Gear position : “3” position
Accelerator opening : 0.6/8 or more
Vehicle speed : 10 km/h (6 MPH) or more

2. Check DTC.

Is “STOP VEHICLE” or “COMPLETED RESULT NG” displayed? / Is “P0733” detected?

- YES-1 >> “STOP VEHICLE”: GO TO 3.
YES-2 >> “COMPLETED RESULT NG”: Go to [TM-62, "Diagnosis Procedure"](#).
YES-3 >> “P0733” is detected: Go to [TM-62, "Diagnosis Procedure"](#).
NO >> Check intermittent incident. Refer to [GI-40, "Intermittent Incident"](#).

3.CHECK SYMPTOM 2

 **With CONSULT-III**

1. Stop vehicle.
2. Drive vehicle in “D” position allowing it to shift from 1GR to 5GR and check shift timing and shift shock.

Is the inspection result normal?

- YES >> Check intermittent incident. Refer to [GI-40, "Intermittent Incident"](#).
NO >> Confirm malfunction phenomena by “ROAD TEST” to repair malfunctioning part. Refer to [TM-151, "Description"](#).

Diagnosis Procedure

INFOID:000000004342909

1.CHECK TCM POWER SUPPLY AND GROUND CIRCUIT

Check TCM power supply and ground circuit. Refer to [TM-88, "Diagnosis Procedure"](#).

Is the inspection result normal?

- YES >> GO TO 2.
NO >> Repair or replace damaged parts.

2.REPLACE CONTROL VALVE WITH TCM

1. Replace control valve with TCM. Refer to [TM-165, "Exploded View"](#).
2. Perform “DTC CONFIRMATION PROCEDURE”. Refer to [TM-61, "DTC Logic"](#).

Is the inspection result normal?

- YES >> INSPECTION END
NO >> Confirm malfunction phenomena by “ROAD TEST” to repair malfunctioning part. Refer to [TM-151, "Description"](#).

P0734 4GR INCORRECT RATIO

< DTC/CIRCUIT DIAGNOSIS >

[5AT: RE5R05A]

P0734 4GR INCORRECT RATIO

Description

INFOID:000000004342910

This malfunction is detected when the A/T does not shift into 4GR position as instructed by TCM. This is not only caused by electrical malfunction (circuits open or shorted) but by mechanical malfunction such as control valve sticking, improper solenoid valve operation, etc.

DTC Logic

INFOID:000000004342911

DTC DETECTION LOGIC

DTC	Item (CONSULT-III screen terms)	A/T CHECK indicator lamp judgment flicker	Diagnostic item is de- tected when...	Possible cause
P0734	4GR INCORRECT RA- TIO	21st	TCM detects any incon- sistency in the actual gear ratio.	<ul style="list-style-type: none"> • Input clutch solenoid valve • Front brake solenoid valve • Direct clutch solenoid valve • High and low reverse clutch solenoid valve • Each clutch and brake • Hydraulic control circuit

DTC CONFIRMATION PROCEDURE

CAUTION:

Always drive vehicle at a safe speed.

NOTE:

If "DTC CONFIRMATION PROCEDURE" has been previously performed, always turn ignition switch OFF. Then wait at least 10 seconds before performing the next test.

1. CHECK ATF TEMPERATURE

With CONSULT-III

1. Start the engine.
2. Select "Data Monitor" in "TRANSMISSION".
3. Check ATF temperature is in the following range.

ATF TEMP 1 : 20°C (68°F) – 140°C (284°F)

With GST

1. Start the engine.
2. Drive vehicle for approximately 5 minutes in urban areas, GO TO 2.

Is ATF temperature within specified range?

YES >> GO TO 2.

NO >> Drive vehicle to warm ATF or stop engine to cool ATF.

2. CHECK SYMPTOM 1

With CONSULT-III

1. Select "DTC & SRT confirmation" in "TRANSMISSION".
2. Select "4TH GR FNCTN P0734".
3. Drive vehicle and maintain the following conditions.

MANU MODE SW : ON

GEAR : "4" position

ACCELE POSI : 0.6/8 or more

VEHICLE SPEED : 10 km/h (6 MPH) or more

P0734 4GR INCORRECT RATIO

< DTC/CIRCUIT DIAGNOSIS >

[5AT: RE5R05A]

ENGINE SPEED : INPUT SPEED – 50 rpm or more
INPUT SPEED : 300 rpm or more

- Keep the current driving status for at least 5 consecutive seconds if CONSULT-III screen changes from “OUT OF CONDITION” to “TESTING”.

CAUTION:

When “TESTING” is not indicated on CONSULT-III for a long time, check “Self Diagnostic Results” mode for “TRANSMISSION”. When a DTC other than “P0734” is detected, check the DTC. Refer to [TM-110, "DTC Index"](#).

 **With GST**

- Drive vehicle and maintain the following conditions for at least 5 consecutive seconds.

Manual mode switch : ON
Gear position : “4” position
Accelerator opening : 0.6/8 or more
Vehicle speed : 10 km/h (6 MPH) or more

- Check DTC.

Is “STOP VEHICLE” or “COMPLETED RESULT NG” displayed? / Is “P0734” detected?

- YES-1 >> “STOP VEHICLE”: GO TO 3.
YES-2 >> “COMPLETED RESULT NG”: Go to [TM-64, "Diagnosis Procedure"](#).
YES-3 >> “P0734” is detected: Go to [TM-64, "Diagnosis Procedure"](#).
NO >> Check intermittent incident. Refer to [GI-40, "Intermittent Incident"](#).

3.CHECK SYMPTOM 2

 **With CONSULT-III**

- Stop vehicle.
- Drive vehicle in “D” position allowing it to shift from 1GR to 5GR and check shift timing and shift shock.

Is the inspection result normal?

- YES >> Check intermittent incident. Refer to [GI-40, "Intermittent Incident"](#).
NO >> Confirm malfunction phenomena by “ROAD TEST” to repair malfunctioning part. Refer to [TM-151, "Description"](#).

Diagnosis Procedure

INFOID:000000004342912

1.CHECK TCM POWER SUPPLY AND GROUND CIRCUIT

Check TCM power supply and ground circuit. Refer to [TM-88, "Diagnosis Procedure"](#).

Is the inspection result normal?

- YES >> GO TO 2.
NO >> Repair or replace damaged parts.

2.REPLACE CONTROL VALVE WITH TCM

- Replace control valve with TCM. Refer to [TM-165, "Exploded View"](#).
- Perform “DTC CONFIRMATION PROCEDURE”. Refer to [TM-63, "DTC Logic"](#).

Is the inspection result normal?

- YES >> INSPECTION END
NO >> Confirm malfunction phenomena by “ROAD TEST” to repair malfunctioning part. Refer to [TM-151, "Description"](#).

P0735 5GR INCORRECT RATIO

< DTC/CIRCUIT DIAGNOSIS >

[5AT: RE5R05A]

P0735 5GR INCORRECT RATIO

Description

INFOID:000000004342913

This malfunction is detected when the A/T does not shift into 5GR position as instructed by TCM. This is not only caused by electrical malfunction (circuits open or shorted) but by mechanical malfunction such as control valve sticking, improper solenoid valve operation, etc.

DTC Logic

INFOID:000000004342914

DTC DETECTION LOGIC

DTC	Item (CONSULT-III screen terms)	A/T CHECK indicator lamp judgment flicker	Diagnostic item is de- tected when...	Possible cause
P0735	5GR INCORRECT RA- TIO	22nd	TCM detects any incon- sistency in the actual gear ratio.	<ul style="list-style-type: none"> • Input clutch solenoid valve • Front brake solenoid valve • Direct clutch solenoid valve • High and low reverse clutch solenoid valve • Each clutch and brake • Hydraulic control circuit

DTC CONFIRMATION PROCEDURE

CAUTION:

Always drive vehicle at a safe speed.

NOTE:

If "DTC CONFIRMATION PROCEDURE" has been previously performed, always turn ignition switch OFF. Then wait at least 10 seconds before performing the next test.

1. CHECK ATF TEMPERATURE

With CONSULT-III

1. Start the engine.
2. Select "Data Monitor" in "TRANSMISSION".
3. Check ATF temperature is in the following range.

ATF TEMP 1 : 20°C (68°F) – 140°C (284°F)

With GST

1. Start the engine.
2. Drive vehicle for approximately 5 minutes in urban areas, GO TO 2.

Is ATF temperature within specified range?

YES >> GO TO 2.

NO >> Drive vehicle to warm ATF or stop engine to cool ATF.

2. CHECK SYMPTOM 1

With CONSULT-III

1. Select "DTC & SRT confirmation" in "TRANSMISSION".
2. Select "5TH GR FNCTN P0735".
3. Drive vehicle and maintain the following conditions.

MANU MODE SW : ON

GEAR : "5" position

ACCELE POSI : 0.6/8 or more

VEHICLE SPEED : 10 km/h (6 MPH) or more

P0735 5GR INCORRECT RATIO

< DTC/CIRCUIT DIAGNOSIS >

[5AT: RE5R05A]

ENGINE SPEED : INPUT SPEED – 50 rpm or more
INPUT SPEED : 300 rpm or more

4. Keep the current driving status for at least 5 consecutive seconds if CONSULT-III screen changes from “OUT OF CONDITION” to “TESTING”.

CAUTION:

When “TESTING” is not indicated on CONSULT-III for a long time, check “Self Diagnostic Results” mode for “TRANSMISSION”. When a DTC other than “P0735” is detected, check the DTC. Refer to [TM-110, "DTC Index"](#).

 **With GST**

1. Drive vehicle and maintain the following conditions for at least 5 consecutive seconds.

Manual mode switch : ON
Gear position : “5” position
Accelerator opening : 0.6/8 or more
Vehicle speed : 10 km/h (6 MPH) or more

2. Check DTC.

Is “STOP VEHICLE” or “COMPLETED RESULT NG” displayed? / Is “P0735” detected?

- YES-1 >> “STOP VEHICLE”: GO TO 3.
YES-2 >> “COMPLETED RESULT NG”: Go to [TM-66, "Diagnosis Procedure"](#).
YES-3 >> “P0735” is detected: Go to [TM-66, "Diagnosis Procedure"](#).
NO >> Check intermittent incident. Refer to [GI-40, "Intermittent Incident"](#).

3.CHECK SYMPTOM 2

 **With CONSULT-III**

1. Stop vehicle.
2. Drive vehicle in “D” position allowing it to shift from 1GR to 5GR and check shift timing and shift shock.

Is the inspection result normal?

- YES >> Check intermittent incident. Refer to [GI-40, "Intermittent Incident"](#).
NO >> Confirm malfunction phenomena by “ROAD TEST” to repair malfunctioning part. Refer to [TM-151, "Description"](#).

Diagnosis Procedure

INFOID:000000004342915

1.CHECK TCM POWER SUPPLY AND GROUND CIRCUIT

Check TCM power supply and ground circuit. Refer to [TM-88, "Diagnosis Procedure"](#).

Is the inspection result normal?

- YES >> GO TO 2.
NO >> Repair or replace damaged parts.

2.REPLACE CONTROL VALVE WITH TCM

1. Replace control valve with TCM. Refer to [TM-165, "Exploded View"](#)
2. Perform “DTC CONFIRMATION PROCEDURE”. Refer to [TM-65, "DTC Logic"](#).

Is the inspection result normal?

- YES >> INSPECTION END.
NO >> Confirm malfunction phenomena by “ROAD TEST” to repair malfunctioning part. Refer to [TM-151, "Description"](#).

P0740 TORQUE CONVERTER

< DTC/CIRCUIT DIAGNOSIS >

[5AT: RE5R05A]

P0740 TORQUE CONVERTER

Description

INFOID:000000004342916

- The torque converter clutch solenoid valve is activated, with the gear in D3, D4, D5, M3, M4 and M5 by the TCM in response to signals transmitted from the output speed sensor and accelerator pedal position sensor (throttle position sensor). Torque converter clutch piston operation will then be controlled.
- Lock-up operation, however, is prohibited when A/T fluid temperature is too low.
- When the accelerator pedal is depressed (less than 1.0/8) in lock-up condition, the engine speed should not change abruptly. If there is a big jump in engine speed, there is no lock-up.

DTC Logic

INFOID:000000004342917

DTC DETECTION LOGIC

DTC	Item (CONSULT-III screen terms)	A/T CHECK indicator lamp judgment flicker	Diagnostic item is detected when...	Possible cause
P0740	TORQUE CONVERTER	3rd	Normal voltage not applied to solenoid due to cut line, short, or the like.	<ul style="list-style-type: none">• Harness or connectors (Solenoid circuit is open or shorted.)• Torque converter clutch solenoid valve

DTC CONFIRMATION PROCEDURE

CAUTION:

Always drive vehicle at a safe speed.

NOTE:

If "DTC CONFIRMATION PROCEDURE" has been previously performed, always turn ignition switch OFF. Then wait at least 10 seconds before performing the next test.

1. CHECK DTC DETECTION

With CONSULT-III

1. Start the engine.
2. Select "Data Monitor" in "TRANSMISSION".
3. Drive vehicle and maintain the following conditions for at least 5 consecutive seconds.

VHCL/S SE-A/T : 80 km/h (50 MPH) or more

ACCELE POSI : 0.5/8 – 1.0/8

SLCT LVR POSI : "D" position

Drive location : Driving the vehicle uphill (increased engine load) will help maintain the driving conditions required for this test.

With GST

Follow the procedure "With CONSULT-III".

Is "P0740" detected?

YES >> Go to [TM-67, "Diagnosis Procedure"](#).

NO >> Check intermittent incident. Refer to [GI-40, "Intermittent Incident"](#).

Diagnosis Procedure

INFOID:000000004342918

1. CHECK TCM POWER SUPPLY AND GROUND CIRCUIT

Check TCM power supply and ground circuit. Refer to [TM-88, "Diagnosis Procedure"](#).

Is the inspection result normal?

YES >> Replace the control valve with TCM. Refer to [TM-165, "Exploded View"](#).

NO >> Repair or replace damaged parts.

P0744 TORQUE CONVERTER

< DTC/CIRCUIT DIAGNOSIS >

[5AT: RE5R05A]

P0744 TORQUE CONVERTER

Description

INFOID:000000004342919

This malfunction is detected when the A/T does not shift into 5GR position or the torque converter clutch does not lock-up as instructed by the TCM. This is not only caused by electrical malfunction (circuits open or shorted) but also by mechanical malfunction such as control valve sticking, improper solenoid valve operation, etc.

DTC Logic

INFOID:000000004342920

DTC DETECTION LOGIC

DTC	Item (CONSULT-III screen terms)	A/T CHECK indicator lamp judgment flicker	Diagnostic item is de- tected when...	Possible cause
P0744	TORQUE CONVERTER	3rd	<ul style="list-style-type: none">A/T cannot perform lock-up even if electrical circuit is good.TCM detects as irregular by comparing difference value with slip rotation.	<ul style="list-style-type: none">Harness or connectors (Sensor circuit is open or shorted.)Torque converter clutch solenoid valveHydraulic control circuit

DTC CONFIRMATION PROCEDURE

CAUTION:

Always drive vehicle at a safe speed.

NOTE:

If "DTC CONFIRMATION PROCEDURE" has been previously performed, always turn ignition switch OFF. Then wait at least 10 seconds before performing the next test.

1. CHECK DTC DETECTION

With CONSULT-III

- Start the engine.
- Select "Data Monitor" in "TRANSMISSION".
- Drive vehicle and maintain the following conditions for at least 30 consecutive seconds.

ACCELE POSI : More than 1.0/8

SLCT LVR POSI : "D" position

TCC SOLENOID : 0.4 – 0.6 A

VEHICLE SPEED : 80 km/h (50 MPH) or more

Driving location : Driving the vehicle uphill (increased engine load) will help maintain the driving conditions required for this test.

With GST

Follow the procedure "With CONSULT-III".

Is "P0744" detected?

YES >> Go to [TM-68, "Diagnosis Procedure"](#).

NO >> Check intermittent incident. Refer to [GI-40, "Intermittent Incident"](#).

Diagnosis Procedure

INFOID:000000004342921

1. CHECK TCM POWER SUPPLY AND GROUND CIRCUIT

Check TCM power supply and ground circuit. Refer to [TM-88, "Diagnosis Procedure"](#).

Is the inspection result normal?

OK >> Replace the control valve with TCM. Refer to [TM-165, "Exploded View"](#).

NG >> Repair or replace damaged parts.

P0745 PRESSURE CONTROL SOLENOID A

< DTC/CIRCUIT DIAGNOSIS >

[5AT: RE5R05A]

P0745 PRESSURE CONTROL SOLENOID A

Description

INFOID:000000004342922

The line pressure solenoid valve regulates the oil pump discharge pressure to suit the driving condition in response to a signal transmitted from the TCM.

DTC Logic

INFOID:000000004342923

DTC DETECTION LOGIC

DTC	Item (CONSULT-III screen terms)	A/T CHECK indicator lamp judgment flicker	Diagnostic item is de- tected when...	Possible cause
P0745	PC SOLENOID A	4th	<ul style="list-style-type: none">Normal voltage not applied to solenoid due to cut line, short, or the like.TCM detects as irregular by comparing target value with monitor value.	<ul style="list-style-type: none">Harness or connectors (Sensor circuit is open or shorted.)Line pressure solenoid valve

DTC CONFIRMATION PROCEDURE

NOTE:

If "DTC CONFIRMATION PROCEDURE" has been previously performed, always turn ignition switch OFF. Then wait at least 10 seconds before performing the next test.

1. CHECK DTC DETECTION

With CONSULT-III

- Start the engine and wait for at least 5 seconds.
- Select "Self Diagnostic Results" in "TRANSMISSION".

With GST

Follow the procedure "With CONSULT-III".

Is "P0745" detected?

- YES >> Go to [TM-69, "Diagnosis Procedure"](#).
NO >> Check intermittent incident. Refer to [GI-40, "Intermittent Incident"](#).

Diagnosis Procedure

INFOID:000000004342924

1. CHECK TCM POWER SUPPLY AND GROUND CIRCUIT

Check TCM power supply and ground circuit. Refer to [TM-88, "Diagnosis Procedure"](#).

Is the inspection result normal?

- YES >> Replace the control valve with TCM. Refer to [TM-165, "Exploded View"](#).
NO >> Repair or replace damaged parts.

P1705 TP SENSOR

< DTC/CIRCUIT DIAGNOSIS >

[5AT: RE5R05A]

P1705 TP SENSOR

Description

INFOID:000000004342925

Electric throttle control actuator consists of throttle control motor, accelerator pedal position sensor, throttle position sensor, etc. The actuator transmits a signal to the ECM, and ECM transmits signals to TCM with CAN communication.

DTC Logic

INFOID:000000004342926

DTC DETECTION LOGIC

DTC	Item (CONSULT-III screen terms)	A/T CHECK indicator lamp judgment flicker	Diagnostic item is de- tected when...	Possible cause
P1705	TP SENSOR	15th	TCM does not receive the proper accelerator pedal position signals (input by CAN communi- cation) from ECM.	Harness or connectors (Sensor circuit is open or shorted.)

DTC CONFIRMATION PROCEDURE

NOTE:

If "DTC CONFIRMATION PROCEDURE" has been previously performed, always turn ignition switch OFF. Then wait at least 10 seconds before performing the next test.

1.CHECK DTC DETECTION

With CONSULT-III

1. Start the engine and let it idle for 1 second.
2. Perform "Self Diagnostic Results" in "TRANSMISSION".

Is "P1705" detected?

- YES >> Go to [TM-70, "Diagnosis Procedure"](#).
NO >> Check intermittent incident. Refer to [GI-40, "Intermittent Incident"](#).

Diagnosis Procedure

INFOID:000000004342927

1.CHECK DTC OF ECM

With CONSULT-III

1. Turn ignition switch ON.
2. Perform "Self Diagnostic Results" in "ENGINE".

Is the inspection result normal?

- YES >> GO TO 2.
NO >> Check DTC detected item. Refer to [EC-534, "DTC Index"](#).

2.CHECK DTC OF TCM

With CONSULT-III

Perform "Self Diagnostic Results" in "TRANSMISSION".

Is any DTC other than "P1705" detected?

- YES >> Check DTC detected item. Refer to [TM-110, "DTC Index"](#).
NO >> GO TO 3.

3.CHECK TCM POWER SUPPLY AND GROUND CIRCUIT

Check TCM power supply and ground circuit. Refer to [TM-88, "Diagnosis Procedure"](#).

Is the inspection result normal?

- YES >> Replace the control valve with TCM. Refer to [TM-165, "Exploded View"](#).
NO >> Repair or replace damaged parts.

P1710 TRANSMISSION FLUID TEMPERATURE SENSOR

< DTC/CIRCUIT DIAGNOSIS >

[5AT: RE5R05A]

P1710 TRANSMISSION FLUID TEMPERATURE SENSOR

Description

INFOID:000000004342928

The A/T fluid temperature sensor detects the A/T fluid temperature and transmits a signal to the TCM.

DTC Logic

INFOID:000000004342929

DTC DETECTION LOGIC

DTC	Item (CONSULT-III screen terms)	A/T CHECK indicator lamp judgment flicker	Diagnostic item is detected when...	Possible cause
P1710	FLUID TEMP SENSOR	10th	While running, the A/T fluid temperature sensor signal voltage is excessively high or low.	<ul style="list-style-type: none"> Harness or connectors (Sensor circuit is open or shorted.) A/T fluid temperature sensors 1 and/or 2

DTC CONFIRMATION PROCEDURE

CAUTION:

Always drive vehicle at a safe speed.

NOTE:

If "DTC CONFIRMATION PROCEDURE" has been previously performed, always turn ignition switch OFF. Then wait at least 10 seconds before performing the next test.

1. CHECK DTC DETECTION

With CONSULT-III

- Start the engine.
- Select "Data Monitor" in "TRANSMISSION".
- Drive vehicle and maintain the following conditions for at least 10 minutes (total). (It is not necessary to maintain continuously.)

VHCL/S SE-A/T : 10 km/h (6 MPH) or more

ACCELE POSI : More than 1.0/8

SLCT LVR POSI : "D" position

With GST

Follow the procedure "With CONSULT-III".

Is "P1710" detected?

YES >> Go to [TM-71, "Diagnosis Procedure"](#).

NO >> Check intermittent incident. Refer to [GI-40, "Intermittent Incident"](#).

Diagnosis Procedure

INFOID:000000004342930

1. CHECK A/T FLUID TEMPERATURE SENSOR 1 SIGNAL

With CONSULT-III

- Start the engine.
- Select "Data Monitor" in "TRANSMISSION".
- Check "ATF TEMP SE 1" and "ATF TEMP SE 2" values.

Item name	Condition °C (°F)	Value (Approx.)
ATF TEMP SE 1	0 (32) – 20 (68) – 80 (176)	3.3 – 2.7 – 0.9 V
ATF TEMP SE 2	0 (32) – 20 (68) – 80 (176)	3.3 – 2.5 – 0.7 V

Which item is abnormal?

ATF TEMP SE 1 >> GO TO 2.

ATF TEMP SE 2 >> GO TO 5.

2. CHECK A/T FLUID TEMPERATURE SENSOR 1

P1710 TRANSMISSION FLUID TEMPERATURE SENSOR

< DTC/CIRCUIT DIAGNOSIS >

[5AT: RE5R05A]

1. Remove control valve with TCM. Refer to [TM-165, "Exploded View"](#).
2. Disconnect park/neutral position switch connector.
3. Check A/T fluid temperature sensor 1. Refer to [TM-73, "Component Inspection \(A/T fluid temperature sensor 1\)"](#).

Is the inspection result normal?

YES >> GO TO 3.

NO >> Repair or replace damaged parts. Refer to [TM-165, "Exploded View"](#).

3.CHECK SUB-HARNESS

1. Disconnect TCM connector.
2. Check continuity between transmission range switch connector terminals and TCM connector terminals.

Transmission range switch connector		TCM connector		Continuity
Connector	Terminal	Connector	Terminal	
F154	6	F152	19	Existed
	7		18	

Is the inspection result normal?

YES >> GO TO 4.

NO >> Repair or replace damaged parts.

4.DETECT MALFUNCTIONING ITEM

Check the following.

- Check terminals of transmission range switch connector and TCM connector and harness cladding for damage.
- Check connector for loose connection.

Is the inspection result normal?

YES >> GO TO 8.

NO >> Repair or replace damaged parts.

5.CHECK A/T FLUID TEMPERATURE SENSOR 2

1. Remove A/T fluid temperature sensor 2. Refer to [TM-171, "Exploded View"](#).
2. Check A/T fluid temperature sensor 2. Refer to [TM-73, "Component Inspection \(A/T fluid temperature sensor 2\)"](#).

Is the inspection result normal?

YES >> GO TO 6.

NO >> Repair or replace damaged parts. Refer to [TM-171, "Exploded View"](#).

6.CHECK TERMINAL CORD ASSEMBLY

1. Remove control valve with TCM. Refer to [TM-165, "Exploded View"](#).
2. Disconnect TCM connector.
3. Check continuity between A/T fluid temperature sensor 2 connector terminals and TCM connector terminals.

A/T fluid temperature sensor 2 connector		TCM connector		Continuity
Connector	Terminal	Connector	Terminal	
F156	1	F151	3	Existed
	2		5	

Is the inspection result normal?

YES >> GO TO 7.

NO >> Repair or replace damaged parts.

7.DETECT MALFUNCTIONING ITEM

Check the following.

- Check terminals of A/T fluid temperature sensor 2 connector and TCM connector, and harness cladding for damage.
- Check connector for loose connection.

P1710 TRANSMISSION FLUID TEMPERATURE SENSOR

< DTC/CIRCUIT DIAGNOSIS >

[5AT: RE5R05A]

Is the inspection result normal?

- YES >> GO TO 8.
- NO >> Repair or replace damaged parts.

8.CHECK TCM POWER SUPPLY AND GROUND CIRCUIT

Check TCM power supply and ground circuit. Refer to [TM-88. "Diagnosis Procedure"](#).

Is the inspection result normal?

- YES >> Replace the control valve with TCM. Refer to [TM-165. "Exploded View"](#).
- NO >> Repair or replace damaged parts.

Component Inspection (A/T fluid temperature sensor 1)

INFOID:000000004342931

1.CHECK A/T FLUID TEMPERATURE SENSOR 1

Check resistance between transmission range switch connector terminals.

Transmission range switch connector			Temperature °C (°F)	Resistance (Approx.)
Connector	Terminal			
F154	6	7	0 (32)	15 kΩ
			20 (68)	6.5 kΩ
			80 (176)	0.9 kΩ

Is the inspection result normal?

- YES >> INSPECTION END
- NO >> Replace control valve with TCM. Refer to [TM-165. "Exploded View"](#).

Component Inspection (A/T fluid temperature sensor 2)

INFOID:000000004342932

1.CHECK A/T FLUID TEMPERATURE SENSOR 2

Check resistance between A/T fluid temperature sensor 2 connector terminals.

A/T fluid temperature sensor 2 connector			Temperature °C (°F)	Resistance (Approx.)
Connector	Terminal			
F156	1	2	0 (32)	10 kΩ
			20 (68)	4 kΩ
			80 (176)	0.5 kΩ

Is the inspection result normal?

- YES >> INSPECTION END
- NO >> Replace the A/T fluid temperature sensor 2. Refer to [TM-171. "Exploded View"](#).

P1721 VEHICLE SPEED SIGNAL

< DTC/CIRCUIT DIAGNOSIS >

[5AT: RE5R05A]

P1721 VEHICLE SPEED SIGNAL

Description

INFOID:000000004342933

The vehicle speed signal is transmitted from unified meter and A/C amp. to TCM by CAN communication line. The signal functions as an auxiliary device to the output speed sensor when it is malfunctioning. The TCM will then use the vehicle speed signal.

DTC Logic

INFOID:000000004342934

DTC DETECTION LOGIC

DTC	Item (CONSULT-III screen terms)	A/T CHECK indicator lamp judgment flicker	Diagnostic item is detected when...	Possible cause
P1721	VEHICLE SPEED SIGNAL	—	<ul style="list-style-type: none">Signal (CAN communication) from vehicle speed signal not input due to cut line or the like.Unexpected signal input during running.	Harness or connectors (Sensor circuit is open or shorted.)

DTC CONFIRMATION PROCEDURE

CAUTION:

Always drive vehicle at a safe speed.

NOTE:

If "DTC CONFIRMATION PROCEDURE" has been previously performed, always turn ignition switch OFF. Then wait at least 10 seconds before performing the next test.

1. CHECK DTC DETECTION

④ With CONSULT-III

1. Start the engine.
2. Select "Data Monitor" in "TRANSMISSION".
3. Drive vehicle and maintain the following conditions for at least 5 consecutive seconds.

VHCL/S SE-MTR : 30 km/h (19 MPH) or more

ACCELE POSI : 1.0/8 or less

Is "P1721" detected?

YES >> Go to [TM-74, "Diagnosis Procedure"](#).

NO >> Check intermittent incident. Refer to [GI-40, "Intermittent Incident"](#).

Diagnosis Procedure

INFOID:000000004342935

1. CHECK DTC OF UNIFIED METER AND A/C AMP.

④ With CONSULT-III

Perform "Self Diagnostic Results" in "METER/M&A".

Is the inspection result normal?

YES >> GO TO 2.

NO >> Check DTC detected item. Refer to [MWI-100, "DTC Index"](#).

2. CHECK TCM POWER SUPPLY AND GROUND CIRCUIT

Check TCM power supply and ground circuit. Refer to [TM-88, "Diagnosis Procedure"](#).

Is the inspection result normal?

YES >> Replace the control valve with TCM. Refer to [TM-165, "Exploded View"](#).

NO >> Repair or replace damaged parts.

P1730 INTERLOCK

< DTC/CIRCUIT DIAGNOSIS >

[5AT: RE5R05A]

P1730 INTERLOCK

Description

INFOID:000000004342936

Fail-safe function to detect interlock conditions.

DTC Logic

INFOID:000000004342937

DTC DETECTION LOGIC

DTC	Item (CONSULT-III screen terms)	A/T CHECK indicator lamp judgment flicker	Diagnostic item is de- tected when...	Possible cause
P1730	INTERLOCK	12th	Except during shift change, the gear posi- tion and ATF pressure switch states are moni- tored and comparative judgment made.	<ul style="list-style-type: none">• Harness or connectors (Solenoid and switch circuit is open or short- ed.)• Low coast brake sole- noid valve• ATF pressure switch 2

NOTE:

When the vehicle is driven fixed in 2GR, a input speed sensor malfunction is displayed, but this is not a input speed sensor malfunction.

DTC CONFIRMATION PROCEDURE

NOTE:

If "DTC CONFIRMATION PROCEDURE" has been previously performed, always turn ignition switch OFF. Then wait at least 10 seconds before performing the next test.

1. CHECK DTC DETECTION

With CONSULT-III

1. Start the engine.
2. Select "Data Monitor" in "TRANSMISSION".
3. Drive vehicle and maintain the following conditions for at least 2 consecutive seconds.

SLCT LVR POSI : "D" position

With GST

Follow the procedure "With CONSULT-III".

Is "P1730" detected?

- YES >> Go to [TM-75. "Diagnosis Procedure"](#).
NO >> Check intermittent incident. Refer to [GI-40. "Intermittent Incident"](#).

Judgment of Interlock

INFOID:000000004342938

Refer to [TM-108. "Fail-Safe"](#).

Diagnosis Procedure

INFOID:000000004342939

1. CHECK TCM POWER SUPPLY AND GROUND CIRCUIT

Check TCM power supply and ground circuit. Refer to [TM-88. "Diagnosis Procedure"](#).

Is the inspection result normal?

- YES >> Replace the control valve with TCM. Refer to [TM-165. "Exploded View"](#).
NO >> Repair or replace damaged parts.

P1731 1ST ENGINE BRAKING

< DTC/CIRCUIT DIAGNOSIS >

[5AT: RE5R05A]

P1731 1ST ENGINE BRAKING

Description

INFOID:000000004342940

Fail-safe function to prevent sudden decrease in speed by engine brake other than at M1 position.

DTC Logic

INFOID:000000004342941

DTC DETECTION LOGIC

DTC	Item (CONSULT-III screen terms)	A/T CHECK indicator lamp judgment flicker	Diagnostic item is de- tected when...	Possible cause
P1731	1ST E/BRAKING	13th	ATF pressure switch 2 and solenoid current is monitor and if a pattern is detected having engine braking 1GR other than in the M1 position, a mal- function is detected.	<ul style="list-style-type: none">• Harness or connectors (Sensor circuit is open or shorted.)• Low coast brake sole- noid valve• ATF pressure switch 2

DTC CONFIRMATION PROCEDURE

NOTE:

If "DTC CONFIRMATION PROCEDURE" has been previously performed, always turn ignition switch OFF. Then wait at least 10 seconds before performing the next test.

1. CHECK DTC DETECTION

With CONSULT-III

1. Start the engine.
2. Select "Data Monitor" in "TRANSMISSION".
3. Drive vehicle and maintain the following conditions for at least 2 consecutive seconds.

ENGINE SPEED : 1,200 rpm

GEAR : "1" position

MANU MODE SW : ON

Is "P1731" detected?

YES >> Go to [TM-76, "Diagnosis Procedure"](#).

NO >> Check intermittent incident. Refer to [GI-40, "Intermittent Incident"](#).

Diagnosis Procedure

INFOID:000000004342942

1. CHECK TCM POWER SUPPLY AND GROUND CIRCUIT

Check TCM power supply and ground circuit. Refer to [TM-88, "Diagnosis Procedure"](#).

Is the inspection result normal?

YES >> Replace the control valve with TCM. Refer to [TM-165, "Exploded View"](#).

NO >> Repair or replace damaged parts.

P1752 INPUT CLUTCH SOLENOID

< DTC/CIRCUIT DIAGNOSIS >

[5AT: RE5R05A]

P1752 INPUT CLUTCH SOLENOID

Description

INFOID:000000004342943

- The Input clutch solenoid valve is controlled by the TCM in response to signals transmitted from the transmission range switch, output speed sensor and accelerator pedal position sensor (throttle position sensor). Gears will then be shifted to the optimum position.
- The Input clutch solenoid valve controls the input clutch control valve in response to a signal transmitted from the TCM.

DTC Logic

INFOID:000000004342944

DTC DETECTION LOGIC

DTC	Item (CONSULT-III screen terms)	A/T CHECK indicator lamp judgment flicker	Diagnostic item is detected when...	Possible cause
P1752	INPUT CLUTCH SOLENOID	5th	<ul style="list-style-type: none">• Normal voltage not applied to solenoid due to cut line, short, or the like.• TCM detects as irregular by comparing target value with monitor value.	<ul style="list-style-type: none">• Harness or connectors (Solenoid circuit is open or shorted.)• Input clutch solenoid valve

DTC CONFIRMATION PROCEDURE

CAUTION:

Always drive vehicle at a safe speed.

NOTE:

If "DTC CONFIRMATION PROCEDURE" has been previously performed, always turn ignition switch OFF. Then wait at least 10 seconds before performing the next test.

1. CHECK DTC DETECTION

With CONSULT-III

1. Start the engine.
2. Select "Data Monitor" in "TRANSMISSION".
3. Drive vehicle and maintain the following conditions for at least 5 consecutive seconds.

ACCELE POSI : 1.5/8 – 2.0/8

GEAR : "3" → "4" (I/C ON/OFF)

SLCT LVR POSI : "D" position

Driving location : Driving the vehicle uphill (increased engine load) will help maintain the driving conditions required for this test.

With GST

Follow the procedure "With CONSULT-III".

Is "P1752" detected?

YES >> Go to [TM-77, "Diagnosis Procedure"](#).

NO >> Check intermittent incident. Refer to [GI-40, "Intermittent Incident"](#).

Diagnosis Procedure

INFOID:000000004342945

1. CHECK TCM POWER SUPPLY AND GROUND CIRCUIT

Check TCM power supply and ground circuit. Refer to [TM-88, "Diagnosis Procedure"](#).

Is the inspection result normal?

YES >> Replace the control valve with TCM. Refer to [TM-165, "Exploded View"](#).

NO >> Repair or replace damaged parts.

P1757 FRONT BRAKE SOLENOID

< DTC/CIRCUIT DIAGNOSIS >

[5AT: RE5R05A]

P1757 FRONT BRAKE SOLENOID

Description

INFOID:000000004342946

- The front brake solenoid valve is controlled by the TCM in response to signals transmitted from the transmission range switch, output speed sensor and accelerator pedal position sensor (throttle position sensor). Gears will then be shifted to the optimum position.
- The front brake solenoid valve controls the front brake control valve in response to a signal transmitted from the TCM.

DTC Logic

INFOID:000000004342947

DTC DETECTION LOGIC

DTC	Item (CONSULT-III screen terms)	A/T CHECK indicator lamp judgment flicker	Diagnostic item is de- tected when...	Possible cause
P1757	FR BRAKE SOLENOID	6th	<ul style="list-style-type: none">• Normal voltage not applied to solenoid due to cut line, short, or the like.• TCM detects as irregular by comparing target value with monitor value.	<ul style="list-style-type: none">• Harness or connectors (Solenoid circuit is open or shorted.)• Front brake solenoid valve

DTC CONFIRMATION PROCEDURE

CAUTION:

Always drive vehicle at a safe speed.

NOTE:

If "DTC CONFIRMATION PROCEDURE" has been previously performed, always turn ignition switch OFF. Then wait at least 10 seconds before performing the next test.

1. CHECK DTC DETECTION

With CONSULT-III

1. Start the engine.
2. Select "Data Monitor" in "TRANSMISSION".
3. Drive vehicle and maintain the following conditions for at least 5 consecutive seconds.

ACCELE POSI : 1.5/8 – 2.0/8

GEAR : "3" → "4" (FR/B ON/OFF)

SLCT LVR POSI : "D" position

Drive location : Driving the vehicle uphill (increased engine load) will help maintain the driving conditions required for this test.

With GST

Follow the procedure "With CONSULT-III".

Is "P1757" detected?

YES >> Go to [TM-78, "Diagnosis Procedure"](#).

NO >> Check intermittent incident. Refer to [GI-40, "Intermittent Incident"](#).

Diagnosis Procedure

INFOID:000000004342948

1. CHECK TCM POWER SUPPLY AND GROUND CIRCUIT

Check TCM power supply and ground circuit. Refer to [TM-88, "Diagnosis Procedure"](#).

Is the inspection result normal?

YES >> Replace the control valve with TCM. Refer to [TM-165, "Exploded View"](#).

NO >> Repair or replace damaged parts.

P1762 DIRECT CLUTCH SOLENOID

< DTC/CIRCUIT DIAGNOSIS >

[5AT: RE5R05A]

P1762 DIRECT CLUTCH SOLENOID

Description

INFOID:000000004342949

- The direct clutch solenoid valve is controlled by the TCM in response to signals transmitted from the transmission range switch, output speed sensor and accelerator pedal position sensor (throttle position sensor). Gears will then be shifted to the optimum position.
- The direct clutch solenoid valve controls the direct clutch control valve in response to a signal transmitted from the TCM.

DTC Logic

INFOID:000000004342950

DTC DETECTION LOGIC

DTC	Item (CONSULT-III screen terms)	A/T CHECK indicator lamp judgment flicker	Diagnostic item is detected when...	Possible cause
P1762	DRCT CLUTCH SOLENOID	2nd	<ul style="list-style-type: none"> • Normal voltage not applied to solenoid due to cut line, short, or the like. • TCM detects as irregular by comparing target value with monitor value. 	<ul style="list-style-type: none"> • Harness or connectors (Solenoid circuit is open or shorted.) • Direct clutch solenoid valve

DTC CONFIRMATION PROCEDURE

CAUTION:

Always drive vehicle at a safe speed.

NOTE:

If "DTC CONFIRMATION PROCEDURE" has been previously performed, always turn ignition switch OFF. Then wait at least 10 seconds before performing the next test.

1. CHECK DTC DETECTION

With CONSULT-III

1. Start the engine.
2. Select "Data Monitor" in "TRANSMISSION".
3. Drive vehicle and maintain the following conditions for at least 5 consecutive seconds.

ACCELE POSI : 1.5/8 – 2.0/8

GEAR : "1" → "2" (D/C ON/OFF)

SLCT LVR POSI : "D" position

Driving location : Driving the vehicle uphill (increased engine load) will help maintain the driving conditions required for this test.

With GST

Follow the procedure "With CONSULT-III".

Is "P1762" detected?

YES >> Go to [TM-79, "Diagnosis Procedure"](#).

NO >> Check intermittent incident. Refer to [GI-40, "Intermittent Incident"](#).

Diagnosis Procedure

INFOID:000000004342951

1. CHECK TCM POWER SUPPLY AND GROUND CIRCUIT

Check TCM power supply and ground circuit. Refer to [TM-88, "Diagnosis Procedure"](#).

Is the inspection result normal?

YES >> Replace the control valve with TCM. Refer to [TM-165, "Exploded View"](#).

NO >> Repair or replace damaged parts.

P1767 HIGH AND LOW REVERSE CLUTCH SOLENOID

< DTC/CIRCUIT DIAGNOSIS >

[5AT: RE5R05A]

P1767 HIGH AND LOW REVERSE CLUTCH SOLENOID

Description

INFOID:000000004342952

- The high and low reverse clutch solenoid valve is controlled by the TCM in response to signals transmitted from the transmission range switch, output speed sensor and accelerator pedal position sensor (throttle position sensor). Gears will then be shifted to the optimum position.
- The high and low reverse clutch solenoid valve controls the high and low reverse clutch control valve in response to a signal transmitted from the TCM.

DTC Logic

INFOID:000000004342953

DTC DETECTION LOGIC

DTC	Item (CONSULT-III screen terms)	A/T CHECK indicator lamp judgment flicker	Diagnostic item is detected when...	Possible cause
P1767	HLR CLUTCH SOLENOID	8th	<ul style="list-style-type: none">• Normal voltage not applied to solenoid due to cut line, short, or the like.• TCM detects as irregular by comparing target value with monitor value.	<ul style="list-style-type: none">• Harness or connectors (Solenoid circuit is open or shorted.)• High and low reverse clutch solenoid valve

DTC CONFIRMATION PROCEDURE

CAUTION:

Always drive vehicle at a safe speed.

NOTE:

If "DTC CONFIRMATION PROCEDURE" has been previously performed, always turn ignition switch OFF. Then wait at least 10 seconds before performing the next test.

1. CHECK DTC DETECTION

With CONSULT-III

1. Start the engine.
2. Select "Data Monitor" in "TRANSMISSION".
3. Drive vehicle and maintain the following conditions for at least 5 consecutive seconds.

ACCELE POSI : 1.5/8 – 2.0/8

GEAR : "2" → "3" (HLR/C ON/OFF)

SLCT LVR POSI : "D" position

Driving location : Driving the vehicle uphill (increased engine load) will help maintain the driving conditions required for this test.

With GST

Follow the procedure "With CONSULT-III".

Is "P1767" detected?

YES >> Go to [TM-80, "Diagnosis Procedure"](#).

NO >> Check intermittent incident. Refer to [GI-40, "Intermittent Incident"](#).

Diagnosis Procedure

INFOID:000000004342954

1. CHECK TCM POWER SUPPLY AND GROUND CIRCUIT

Check TCM power supply and ground circuit. Refer to [TM-88, "Diagnosis Procedure"](#).

Is the inspection result normal?

YES >> Replace the control valve with TCM. Refer to [TM-165, "Exploded View"](#).

NO >> Repair or replace damaged parts.

P1772 LOW COAST BRAKE SOLENOID

< DTC/CIRCUIT DIAGNOSIS >

[5AT: RE5R05A]

P1772 LOW COAST BRAKE SOLENOID

Description

INFOID:000000004342955

- The low coast brake solenoid valve is turned ON or OFF by the TCM in response to signals transmitted from the transmission range switch, output speed sensor and accelerator pedal position sensor (throttle position sensor). Gears will then be shifted to the optimum position.
- The low coast brake solenoid valve controls the low coast brake switching valve in response to a signal transmitted from the TCM.

DTC Logic

INFOID:000000004342956

DTC DETECTION LOGIC

DTC	Item (CONSULT-III screen terms)	A/T CHECK indicator lamp judgment flicker	Diagnostic item is detected when...	Possible cause
P1772	L C BRAKE SOLENOID	7th	Normal voltage not applied to solenoid due to cut line, short, or the like.	<ul style="list-style-type: none"> • Harness or connectors (Solenoid circuit is open or shorted.) • Low coast brake solenoid valve

DTC CONFIRMATION PROCEDURE

CAUTION:

Always drive vehicle at a safe speed.

NOTE:

If "DTC CONFIRMATION PROCEDURE" has been previously performed, always turn ignition switch OFF. Then wait at least 10 seconds before performing the next test.

1. CHECK DTC DETECTION

With CONSULT-III

1. Start the engine.
2. Select "Data Monitor" in "TRANSMISSION".
3. Drive vehicle and maintain the following conditions for at least 5 consecutive seconds.

GEAR : "1" or "2" (LC/B ON/OFF)

MANU MODE SW : ON

With GST

Follow the procedure "With CONSULT-III".

Is "P1772" detected?

YES >> Go to [TM-81, "Diagnosis Procedure"](#).

NO >> Check intermittent incident. Refer to [GI-40, "Intermittent Incident"](#).

Diagnosis Procedure

INFOID:000000004342957

1. CHECK TCM POWER SUPPLY AND GROUND CIRCUIT

Check TCM power supply and ground circuit. Refer to [TM-88, "Diagnosis Procedure"](#).

Is the inspection result normal?

YES >> Replace the control valve with TCM. Refer to [TM-165, "Exploded View"](#).

NO >> Repair or replace damaged parts.

P1774 LOW COAST BRAKE SOLENOID

< DTC/CIRCUIT DIAGNOSIS >

[5AT: RE5R05A]

P1774 LOW COAST BRAKE SOLENOID

Description

INFOID:000000004342958

- Low coast brake solenoid valve is turned ON or OFF by the TCM in response to signals transmitted from the transmission range switch, output speed sensor and accelerator pedal position sensor (throttle position sensor). Gears will then be shifted to the optimum position.
- This is not only caused by electrical malfunction (circuits open or shorted) but also by mechanical malfunction such as control valve sticking, improper solenoid valve operation.

DTC Logic

INFOID:000000004342959

DTC DETECTION LOGIC

DTC	Item (CONSULT-III screen terms)	A/T CHECK indicator lamp judgment flicker	Diagnostic item is de- tected when...	Possible cause
P1774	L C BRAKE SOLENOID	7th	<ul style="list-style-type: none">• TCM detects an im- proper voltage drop when it tries to operate the solenoid valve.• Condition of ATF pres- sure switch 2 is differ- ent from monitor value, and relation be- tween gear position and actual gear ratio is irregular.	<ul style="list-style-type: none">• Harness or connectors (Solenoid and switch circuit is open or short- ed.)• Low coast brake sole- noid valve• ATF pressure switch 2

DTC CONFIRMATION PROCEDURE

CAUTION:

Always drive vehicle at a safe speed.

NOTE:

If "DTC CONFIRMATION PROCEDURE" has been previously performed, always turn ignition switch OFF. Then wait at least 10 seconds before performing the next test.

1. CHECK DTC DETECTION

Ⓜ With CONSULT-III

1. Start the engine.
2. Select "Data Monitor" in "TRANSMISSION".
3. Drive vehicle and maintain the following conditions.

GEAR : "1" or "2" (LC/B ON/OFF)

MANU MODE SW : ON

4. Stop vehicle and perform step 3 again.
5. Stop vehicle.
6. Turn ignition switch OFF, then perform step 1 to 4 again.

Ⓜ With GST

Follow the procedure "With CONSULT-III".

Is "P1774" detected?

YES >> Go to [TM-82, "Diagnosis Procedure"](#).

NO >> Check intermittent incident. Refer to [GI-40, "Intermittent Incident"](#).

Diagnosis Procedure

INFOID:000000004342960

1. CHECK TCM POWER SUPPLY AND GROUND CIRCUIT

Check TCM power supply and ground circuit. Refer to [TM-88, "Diagnosis Procedure"](#).

Is the inspection result normal?

YES >> Replace the control valve with TCM. Refer to [TM-165, "Exploded View"](#).

P1774 LOW COAST BRAKE SOLENOID

< DTC/CIRCUIT DIAGNOSIS >

[5AT: RE5R05A]

NO >> Repair or replace damaged parts.

A

B

C

TM

E

F

G

H

I

J

K

L

M

N

O

P

P1815 M-MODE SWITCH

< DTC/CIRCUIT DIAGNOSIS >

[5AT: RE5R05A]

P1815 M-MODE SWITCH

Description

INFOID:000000004342961

Manual mode switch is installed in control device assembly. It transmits manual mode switch, shift up and shift down switch signals to unified meter and A/C amp. Then unified meter and A/C amp. transmits signals to TCM with CAN communication.

TCM transmits the switch signals to unified meter and A/C amp. by CAN communication line. Then manual mode switch position is indicated on the A/T indicator. For inspection, refer to [TM-90](#).

DTC Logic

INFOID:000000004342962

DTC DETECTION LOGIC

DTC	Item (CONSULT-III screen terms)	A/T CHECK indicator lamp judgment flicker	Diagnostic item is detect- ed when...	Possible cause
P1815	M-MODE SWITCH	—	TCM monitors manual mode, non manual mode, up or down switch signal, and detects as irregular when impossible input pattern occurs 2 second or more.	<ul style="list-style-type: none">• Harness or connectors (These switches circuit is open or shorted.)• Manual mode select switch (Into A/T shift selector)• Manual mode position select switch (Into A/T shift selector)

DTC CONFIRMATION PROCEDURE

CAUTION:

Always drive vehicle at a safe speed.

NOTE:

If "DTC CONFIRMATION PROCEDURE" has been previously performed, always turn ignition switch OFF. Then wait at least 10 seconds before performing the next test.

1. CHECK DTC DETECTION

With CONSULT-III

1. Start the engine.
2. Select "Data Monitor" in "TRANSMISSION".
3. Drive vehicle and maintain the following conditions for at least 2 consecutive seconds.

MANU MODE SW : ON

Is "P1815" detected?

YES >> Go to [TM-84, "Diagnosis Procedure"](#).

NO >> Check intermittent incident. Refer to [GI-40, "Intermittent Incident"](#).

Diagnosis Procedure

INFOID:000000004342963

1. CHECK MANUAL MODE SWITCH CIRCUIT

1. Turn ignition switch OFF.
2. Disconnect A/T shift selector connector.
3. Turn ignition switch ON.
4. Check voltage between A/T shift selector vehicle side harness connector terminals.

P1815 M-MODE SWITCH

< DTC/CIRCUIT DIAGNOSIS >

[5AT: RE5R05A]

A/T shift selector vehicle side harness connector		Terminal	Voltage (Approx.)
Connector	+		
M137	1	4	Battery voltage
	2		
	3		
	5		

Is the inspection result normal?

- YES >> GO TO 2.
- NO >> GO TO 4.

2.CHECK MANUAL MODE SWITCH

Check manual mode switch. Refer to [TM-86. "Component Inspection \(Manual Mode Switch\)"](#).

Is the inspection result normal?

- YES >> GO TO 3.
- NO >> Repair or replace damaged parts.

3.CHECK MALFUNCTIONING ITEM

Check the following.

- Check terminals of A/T shift selector harness connector and harness cladding for damage.
- Check connector for loose connection.

Is the inspection result normal?

- YES >> GO TO 8.
- NO >> Repair or replace damaged parts.

4.CHECK GROUND CIRCUIT

Check continuity between A/T shift selector vehicle side harness connector terminal and ground.

A/T shift selector vehicle side harness connector		Ground	Continuity
Connector	Terminal		
M137	4		Existed

Is the inspection result normal?

- YES >> GO TO 5.
- NO >> Repair or replace damaged parts.

5.CHECK HARNESS BETWEEN A/T SHIFT SELECTOR AND UNIFIED METER AND A/C AMP. (PART 1)

1. Turn ignition switch OFF.
2. Disconnect unified meter and A/C amp. connector.
3. Check continuity between A/T shift selector vehicle side harness connector terminals and unified meter and A/C amp. vehicle side harness connector terminals.

A/T shift selector vehicle side harness connector		Unified meter and A/C amp. vehicle side harness connector		Continuity
Connector	Terminal	Connector	Terminal	
M137	1	M66	10	Existed
	2		25	
	3		5	
	5		11	

Is the inspection result normal?

- YES >> GO TO 6.
- NO >> Repair or replace damaged parts.

6.CHECK HARNESS BETWEEN A/T SHIFT SELECTOR AND UNIFIED METER AND A/C AMP. (PART 2)

P1815 M-MODE SWITCH

< DTC/CIRCUIT DIAGNOSIS >

[5AT: RE5R05A]

Check continuity between A/T shift selector vehicle side harness connector terminals and ground.

A/T shift selector vehicle side harness connector		Ground	Continuity
Connector	Terminal		
M137	1	Ground	Not existed
	2		
	3		
	5		

Is the inspection result normal?

- YES >> GO TO 7.
- NO >> Repair or replace damaged parts.

7.CHECK MALFUNCTIONING ITEM

Check the following.

- Check terminals of unified meter and A/C amp. connector for damage.
- Check connector for loose connection.

Is the inspection result normal?

- YES >> GO TO 8.
- NO >> Repair or replace damaged parts.

8.CHECK UNIFIED METER AND A/C AMP.

1. Reconnect all the connectors.
2. Turn ignition switch ON.
3. Select "M RANGE SW", "NM RANGE SW", "AT SFT UP SW" and "AT SFT DWN SW" in "Data Monitor" in "METER/M&A", and check the On/Off operations of each monitor item. Refer to [MWI-84. "Reference Value"](#).

Is the inspection result normal?

- YES >> GO TO 9.
- NO >> Replace unified meter and A/C amp. Refer to [MWI-126. "Exploded View"](#).

9.CHECK TCM POWER SUPPLY AND GROUND CIRCUIT

Check TCM power supply and ground circuit. Refer to [TM-88. "Diagnosis Procedure"](#).

Is the inspection result normal?

- YES >> Replace the control valve with TCM. Refer to [TM-165. "Exploded View"](#).
- NO >> Repair or replace damaged parts.

Component Inspection (Manual Mode Switch)

INFOID:000000004342964

1.CHECK MANUAL MODE SWITCH

Check continuity between terminals.

A/T shift selector harness connector		Condition	Continuity
Connector	Terminal		
M137	1	Selector lever is shifted to manual shift gate side	Existed
		Other than the above	Not existed
	2	Selector lever is shifted to – side	Existed
		Other than the above	Not existed
	3	Selector lever is shifted to + side	Existed
		Other than the above	Not existed
	5	Selector lever is shifted to "D" position	Existed
		Other than the above	Not existed

Is the inspection result normal?

- YES >> INSPECTION END

P1815 M-MODE SWITCH

< DTC/CIRCUIT DIAGNOSIS >

[5AT: RE5R05A]

NO >> Repair or replace damaged parts. Refer to [TM-157, "2WD : Exploded View"](#) (2WD), [TM-160, "AWD : Exploded View"](#) (AWD).

A

B

C

TM

E

F

G

H

I

J

K

L

M

N

O

P

MAIN POWER SUPPLY AND GROUND CIRCUIT

< DTC/CIRCUIT DIAGNOSIS >

[5AT: RE5R05A]

MAIN POWER SUPPLY AND GROUND CIRCUIT

Description

INFOID:000000004342965

Supply power to TCM.

Diagnosis Procedure

INFOID:000000004342966

1. CHECK TCM POWER SOURCE CIRCUIT

1. Turn ignition switch OFF.
2. Disconnect A/T assembly connector.
3. Check voltage between A/T assembly vehicle side harness connector terminals and ground.

A/T assembly vehicle side harness connector		Ground	Condition	Voltage (Approx.)
Connector	Terminal		Always	Battery voltage
F51	1		Turn ignition switch ON	Battery voltage
	2		Turn ignition switch OFF	
	6			

Is the inspection result normal?

YES >> GO TO 2.

NO >> Check the following. If NG, repair or replace damaged parts.

- Harness for short or open between battery and A/T assembly vehicle side harness connector terminals 1, 2.
- Harness for short or open between ignition switch and A/T assembly vehicle side harness connector terminal 6.
- 10A fuse (No. 36, located in the fuse, fusible link and relay box)
- 10A fuse (No. 43, located in the IPDM E/R)
- Push-button ignition switch. Refer to [PG-53, "Wiring Diagram - IGNITION POWER SUPPLY -"](#).

2. CHECK TCM GROUND CIRCUIT

Check continuity between A/T assembly vehicle side harness connector terminals and ground.

A/T assembly vehicle side harness connector		Ground	Continuity
Connector	Terminal		Existed
F51	5		Existed
	10		

Is the inspection result normal?

YES >> GO TO 3.

NO >> Repair or replace damaged parts.

3. DETECT MALFUNCTIONING ITEM (PART 1)

Check the following.

- Check terminals of A/T assembly connector for damage.
- Check connector for loose connection.

Is the inspection result normal?

YES >> GO TO 4.

NO >> Repair or replace damaged parts.

4. CHECK TERMINAL CORD ASSEMBLY

1. Remove control valve with TCM. Refer to [TM-165, "Exploded View"](#).
2. Disconnect TCM connector.
3. Check continuity between A/T assembly connector terminals and TCM connector terminals.

MAIN POWER SUPPLY AND GROUND CIRCUIT

< DTC/CIRCUIT DIAGNOSIS >

[5AT: RE5R05A]

A/T assembly connector		TCM connector		Continuity
Connector	Terminal	Connector	Terminal	
F51	1	F151	9	Existed
	2		10	
	6		4	
	5	F153	21	
	10		22	

Is the inspection result normal?

YES >> GO TO 5.

NO >> Repair or replace damaged parts.

5. DETECT MALFUNCTIONING ITEM (PART 2)

Check the following.

- Check terminals of TCM connector and harness cladding for damage.
- Check connector for loose connection.

Is the inspection result normal?

YES >> INSPECTION END

NO >> Repair or replace damaged parts.

A
B
C
TM
E
F
G
H
I
J
K
L
M
N
O
P

SHIFT POSITION INDICATOR CIRCUIT

< DTC/CIRCUIT DIAGNOSIS >

[5AT: RE5R05A]

SHIFT POSITION INDICATOR CIRCUIT

Description

INFOID:000000004342967

TCM transmit the switch signals to unified meter and A/C amp. by CAN communication line. Then manual mode switch position is indicated on the shift position indicator.

Component Function Check

INFOID:000000004342968

1. CHECK A/T INDICATOR

1. Start the engine.
2. Check the actual selector lever position ("P", "R", "N", "D" and "DS") and the indication of the shift position indicator mutually coincide.
3. Drive vehicle in the manual mode, and confirm that the actual gear position and the meter's indication of the position mutually coincide when the selector lever is shifted to the "UP (+ side)" or "DOWN (- side)" side (1GR ⇔ 5GR).

Is the inspection result normal?

- YES >> INSPECTION END
NO >> Go to [TM-90, "Diagnosis Procedure"](#).

Diagnosis Procedure

INFOID:000000004342969

1. CHECK INPUT SIGNALS

Ⓟ With CONSULT-III

1. Start the engine.
2. Select "SLCT LVR POSI" in "Data Monitor" in "TRANSMISSION" and read out the value.
3. Check the actual selector lever position ("P", "R", "N", "D" and "DS") and the indication of the shift position indicator mutually coincide. Refer to [TM-101, "Reference Value"](#).
4. Drive vehicle in the manual mode, and confirm that the actual gear position and the meter's indication of the position mutually coincide when the selector lever is shifted to the "UP (+ side)" or "DOWN (- side)" side (1GR ⇔ 5GR).

Is the inspection result normal?

- YES >> INSPECTION END
- NO-1 >> The actual gear position does not change, or shifting into the manual mode is not possible (no gear shifting in the manual mode possible). Or the shift position indicator is not indicated.
- Check manual mode switch. Refer to [TM-86, "Component Inspection \(Manual Mode Switch\)"](#).
 - Check A/T main system (Fail-safe function actuated).
 - Perform "Self Diagnostic Results" in "TRANSMISSION". Refer to [TM-110, "DTC Index"](#).
- NO-2 >> The actual gear position changes, but the shift position indicator is not indicated.
- Perform "Self Diagnostic Results" in "TRANSMISSION". Refer to [TM-110, "DTC Index"](#).
- NO-3 >> The actual gear position and the indication on the shift position indicator do not coincide.
- Perform "Self Diagnostic Results" in "TRANSMISSION". Refer to [TM-110, "DTC Index"](#).
- NO-4 >> Only a specific position or positions is/are not indicated on the shift position indicator.
- Replace the unified meter and A/C amp. Refer to [MWI-126, "Exploded View"](#).

SHIFT LOCK SYSTEM

< DTC/CIRCUIT DIAGNOSIS >

[5AT: RE5R05A]

SHIFT LOCK SYSTEM

Description

INFOID:0000000004342970

Refer to [TM-34, "System Description"](#).

Wiring Diagram - A/T SHIFT LOCK SYSTEM -

INFOID:0000000004342971

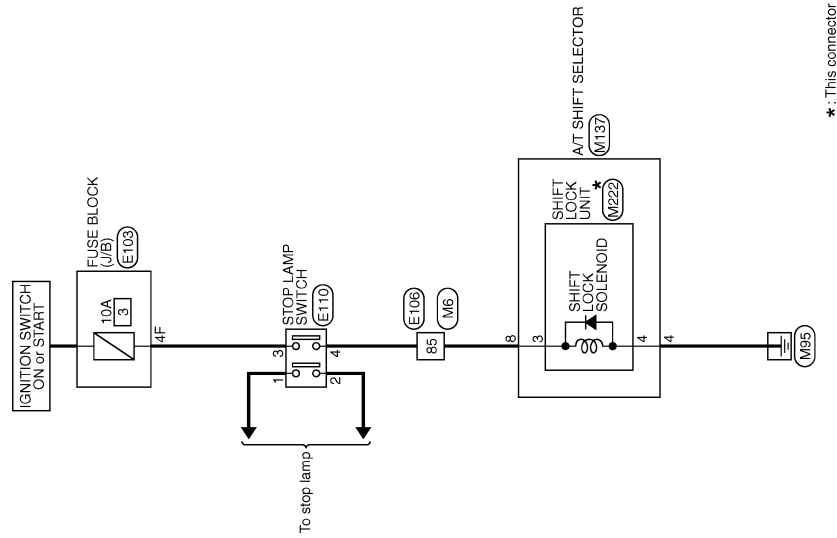

*: This connector is not shown in "Harness Layout".

A/T SHIFT LOCK SYSTEM

A
B
C
TM
E
F
G
H
I
J
K
L
M
N
O
P

A/T SHIFT LOCK SYSTEM

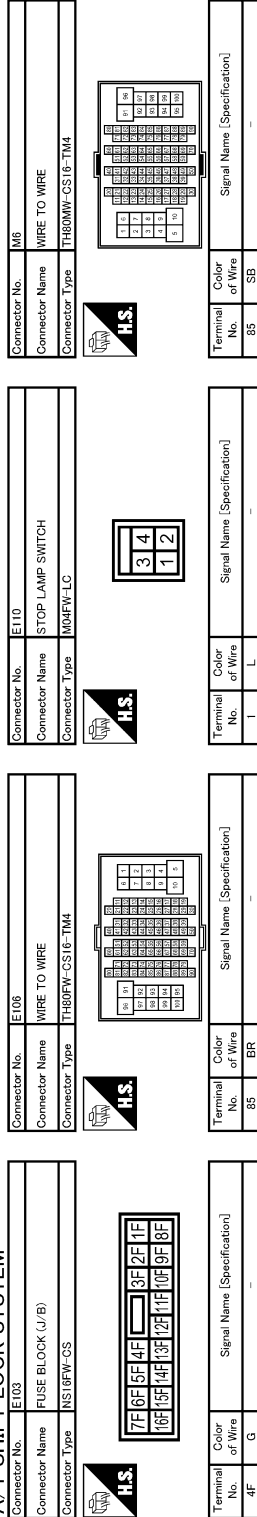

Component Function Check

1. CHECK A/T SHIFT LOCK OPERATION (PART 1)

1. Turn ignition switch ON.
2. Shift the selector lever to “P” position.
3. Attempt to shift the selector lever to any other position with the brake pedal released.

Can the selector lever be shifted to any other position?

JCDWA0359GB

INFOID:000000004507193

SHIFT LOCK SYSTEM

< DTC/CIRCUIT DIAGNOSIS >

[5AT: RE5R05A]

- YES >> Go to [TM-93, "Diagnosis Procedure"](#).
NO >> GO TO 2.

2.CHECK A/T SHIFT LOCK OPERATION (PART 2)

Attempt to shift the selector lever to any other position with the brake pedal depressed.

Can the selector lever be shifted to any other position?

- YES >> INSPECTION END
NO >> Go to [TM-93, "Diagnosis Procedure"](#).

Diagnosis Procedure

INFOID:000000004507192

1.CHECK SELECTOR LEVER POSITION

Check the selector lever position for damage. Refer to [TM-155, "2WD : Inspection and Adjustment"](#) (2WD), [TM-155, "AWD : Inspection and Adjustment"](#) (AWD).

Is the inspection result normal?

- YES >> GO TO 2.
NO >> Adjust control linkage. Refer to [TM-155, "2WD : Inspection and Adjustment"](#) (2WD), [TM-155, "AWD : Inspection and Adjustment"](#) (AWD).

2.CHECK POWER SOURCE

1. Disconnect stop lamp switch connector.
2. Turn ignition switch ON.
3. Check voltage between stop lamp switch vehicle side harness connector terminal and ground.

Stop lamp switch vehicle side harness connector		Ground	Condition	Voltage (Approx.)
Connector	Terminal			
E110	3	Depressed brake pedal	Battery voltage	
		Released brake pedal	0 V	

Is the inspection result normal?

- YES >> GO TO 3.
NO >> Check the following. If NG, repair or replace damaged parts.
- 10A fuse [No. 3, located in the fuse block (J/B)]
 - Harness for short to ground or open between battery and fuse block (J/B).
 - Harness for short to ground or open between fuse block (J/B) vehicle side harness connector terminal 4F and stop lamp switch vehicle side harness connector terminal 3.

3.CHECK STOP LAMP SWITCH

Check stop lamp switch. Refer to [TM-94, "Component Inspection \(Stop lamp switch\)"](#).

Is the inspection result normal?

- YES >> GO TO 4.
NO >> Replace damaged parts.

4.CHECK GROUND CIRCUIT

1. Disconnect A/T shift selector connector.
2. Check continuity between A/T shift selector vehicle side harness connector terminal and ground.

Stop lamp switch vehicle side harness connector		Ground	Continuity
Connector	Terminal		
M137	4	Existed	

Is the inspection result normal?

- YES >> GO TO 5.
NO >> Repair or replace damaged parts.

5.CHECK HARNESS BETWEEN STOP LAMP SWITCH AND A/T SHIFT SELECTOR (PART 1)

Check continuity between stop lamp switch vehicle side harness connector terminal and A/T shift selector vehicle side harness connector terminal.

SHIFT LOCK SYSTEM

< DTC/CIRCUIT DIAGNOSIS >

[5AT: RE5R05A]

Stop lamp switch vehicle side harness connector		A/T shift selector vehicle side harness connector		Continuity
Connector	Terminal	Connector	Terminal	
E110	4	M137	8	Existed

Is the inspection result normal?

- YES >> GO TO 6.
 NO >> Repair or replace damaged parts.

6. CHECK HARNESS BETWEEN STOP LAMP SWITCH AND A/T SHIFT SELECTOR (PART 2)

Check continuity between stop lamp switch vehicle side harness connector terminal and ground.

Stop lamp switch vehicle side harness connector		Ground	Continuity
Connector	Terminal		
E110	4		Not existed

Is the inspection result normal?

- YES >> GO TO 7.
 NO >> Repair or replace damaged parts.

7. CHECK SHIFT LOCK UNIT

1. Remove shift lock unit. Refer to [TM-157, "2WD : Exploded View"](#) (2WD), [TM-160, "AWD : Exploded View"](#) (AWD).
2. Check shift lock solenoid. Refer to [TM-94, "Component Inspection \(Shift lock solenoid\)"](#).

Is the inspection result normal?

- YES >> Check the following.
- Harness for short to ground or open between A/T shift selector connector terminal 8 and shift lock solenoid A/T shift selector side harness connector terminal 3.
 - Harness for open between A/T shift selector connector terminal 4 and shift lock solenoid A/T shift selector side harness connector terminal 4.
- NO >> Replace damaged parts.

Component Inspection (Shift lock solenoid)

INFOID:000000004507194

1. CHECK SHIFT LOCK SOLENOID

Apply voltage to terminals 3 and 4 of shift lock unit connector, and then check that shift lock solenoid is activated.

CAUTION:

Connect the fuse between the terminals when applying the voltage.

Shift lock unit connector			Condition	Status
Connector	Terminal			
		(+) (fuse)	(-)	
M222	3	4	Apply 12 V direct current between terminals 3 and 4.	Shift lock solenoid operates

Can the lock plate be moved up and down?

- YES >> INSPECTION END
 NO >> Replace shift lock unit. Refer to [TM-157, "2WD : Exploded View"](#) (2WD), [TM-160, "AWD : Exploded View"](#) (AWD).

Component Inspection (Stop lamp switch)

INFOID:000000004507195

1. CHECK STOP LAMP SWITCH

Check continuity between stop lamp switch connector terminals.

SHIFT LOCK SYSTEM

< DTC/CIRCUIT DIAGNOSIS >

[5AT: RE5R05A]

Stop lamp switch connector			Condition	Continuity
Connector	Terminal			
E110	3	4	Depressed brake pedal.	Existed
			Released brake pedal.	Not existed

Is the inspection result normal?

YES >> INSPECTION END

NO >> Replace stop lamp switch. Refer to [TM-157, "2WD : Exploded View"](#) (2WD), [TM-160, "AWD : Exploded View"](#) (AWD).

A
B
C
E
F
G
H
I
J
K
L
M
N
O
P

TM

SELECTOR LEVER POSITION INDICATOR

< DTC/CIRCUIT DIAGNOSIS >

[5AT: RE5R05A]

SELECTOR LEVER POSITION INDICATOR

Description

INFOID:000000004342977

Indicates selector lever position.

Component Function Check

INFOID:000000004342978

1.CHECK SELECTOR LEVER POSITION INDICATOR (STEP 1)

1. Turn ignition switch ON.
2. Check that each position indicator lamp of the selector lever position indicator turns on when shifting the selector lever from "P" to "M" position.

Is the inspection result normal?

- YES >> GO TO 2.
 NO >> Go to [TM-96. "Diagnosis Procedure"](#).

2.CHECK SELECTOR LEVER POSITION INDICATOR (STEP 2)

Check that the night illumination of the selector lever position indicator turns on when setting the lighting switch in 1st position.

Is the inspection result normal?

- YES >> INSPECTION END
 NO >> Go to [TM-96. "Diagnosis Procedure"](#).

Diagnosis Procedure

INFOID:000000004546561

1.CHECK MALFUNCTIONING ITEM

Which item is abnormal?

- Position indicator lamp>> GO TO 2.
 Illumination lamp>> GO TO 11.

2.CHECK POWER SOURCE

1. Turn ignition switch OFF.
2. Disconnect A/T shift selector connector.
3. Turn ignition switch ON.
4. Check voltage between A/T shift selector vehicle side harness connector terminals.

A/T shift selector vehicle side harness connector			Voltage (Approx.)
Connector	Terminal		
		+	-
M137	10	4	Battery voltage

Is the inspection result normal?

- YES >> GO TO 7.
 NO >> GO TO 3.

3.CHECK GROUND CIRCUIT

Check continuity between A/T shift selector vehicle side harness connector terminal and ground.

A/T shift selector vehicle side harness connector		Ground	Continuity
Connector	Terminal		
M137	4		Existed

Is the inspection result normal?

- YES >> GO TO 4.
 NO >> Repair or replace damaged parts.

SELECTOR LEVER POSITION INDICATOR

< DTC/CIRCUIT DIAGNOSIS >

[5AT: RE5R05A]

4. CHECK HARNESS BETWEEN A/T SHIFT SELECTOR AND BCM (PART 1)

1. Turn ignition switch OFF.
2. Disconnect BCM connector.
3. Check continuity between A/T shift selector vehicle side harness connector terminal and BCM vehicle side harness connector terminal.

A/T shift selector vehicle side harness connector		BCM vehicle side harness connector		Continuity
Connector	Terminal	Connector	Terminal	
M137	10	M122	96	Existed

Is the inspection result normal?

- YES >> GO TO 5.
 NO >> Repair or replace damaged parts.

5. CHECK HARNESS BETWEEN A/T SHIFT SELECTOR AND BCM (PART 2)

Check continuity between A/T shift selector vehicle side harness connector terminal and ground.

A/T shift selector harness connector		Ground	Continuity
Connector	Terminal		
M137	10		Not existed

Is the inspection result normal?

- YES >> GO TO 6.
 NO >> Repair or replace damaged parts.

6. CHECK MALFUNCTION ITEM

Check the following.

- Check terminals and harness of BCM harness connector and A/T shift selector harness connector for damage.
- Check connector for loose connection.

Is the inspection result normal?

- YES >> Check BCM input/output signal. Refer to [BCS-46. "Reference Value"](#).
 NO >> Repair or replace damaged parts.

7. CHECK SHIFT POSITION SWITCH

1. Disconnect shift position switch connector.
2. Check continuity between A/T shift selector harness connector terminals and shift position switch connector terminals.

A/T shift selector harness connector		Shift position switch connector		Condition	Continuity
Connector	Terminal	Connector	Terminal		
M137	4	M221	7	Selector lever in "D" position.	Existed
			2, 3, 4, 5, 6, 9, 10, 11		No existed
			9	Selector lever in "M" position.	Existed
			2, 3, 4, 5, 6, 7, 10, 11		No existed
	10		2, 6	Selector lever in "N" and "M" position.	Existed
			3, 4, 5, 7, 9, 10, 11		No existed
			3, 6	Selector lever in "D" position.	Existed
			2, 4, 5, 7, 9, 10, 11		No existed
			4, 6	Selector lever in "R" position.	Existed
			2, 3, 5, 7, 9, 10, 11		No existed
5, 6	Selector lever in "P" position.	Existed			
2, 3, 4, 7, 9, 10, 11		No existed			

Is the inspection result normal?

SELECTOR LEVER POSITION INDICATOR

< DTC/CIRCUIT DIAGNOSIS >

[5AT: RE5R05A]

YES >> GO TO 8.

NO >> Repair or replace damaged parts. Refer to [TM-157, "2WD : Exploded View"](#) (2WD), [TM-160, "AWD : Exploded View"](#) (AWD).

8. CHECK HARNESS BETWEEN SHIFT POSITION SWITCH AND SELECTOR LEVER POSITION INDICATOR (PART 1)

1. Disconnect selector lever position indicator connector.
2. Check continuity between shift position switch harness connector terminals and selector lever position indicator connector terminals.

Shift position switch harness connector		Selector lever position indicator harness connector		Continuity
Connector	Terminal	Connector	Terminal	
M221	2	M223	3	Existed
	3		4	
	4		5	
	5		7	
	6		6	
	7		8	
	9		2	

Is the inspection result normal?

YES >> GO TO 9.

NO >> Repair or replace damaged parts. Refer to [TM-157, "2WD : Exploded View"](#) (2WD), [TM-160, "AWD : Exploded View"](#) (AWD).

9. CHECK HARNESS BETWEEN SHIFT POSITION SWITCH AND SELECTOR LEVER POSITION INDICATOR (PART 2)

Check harness cladding between shift position switch connector and selector lever position indicator connector for damage.

Is the inspection result normal?

YES >> GO TO 10.

NO >> Repair or replace damaged parts. Refer to [TM-157, "2WD : Exploded View"](#) (2WD), [TM-160, "AWD : Exploded View"](#) (AWD).

10. CHECK SELECTOR LEVER POSITION INDICATOR

Check selector lever position indicator. Refer to [TM-99, "Component Inspection"](#).

Is the inspection result normal?

YES >> Check the following.

- Check terminals of A/T shift selector connector, shift position switch connector and selector lever position indicator connector for damage.
- Check connector for loose connection.

NO >> Replace damaged parts.

11. CHECK POWER SOURCE

1. Turn ignition switch OFF.
2. Disconnect A/T shift selector connector.
3. Turn ignition switch ON.
4. Check voltage between A/T shift selector vehicle side harness connector terminals.

A/T shift selector vehicle side harness connector			Condition	Voltage (Approx.)
Connector	Terminal			
	+	-		
M137	7	9	Lighting switch 1ST	Battery voltage

Is the inspection result normal?

YES >> GO TO 12.

NO >> Check illumination circuit. Refer to [INL-37, "Wiring Diagram - ILLUMINATION -"](#).

SELECTOR LEVER POSITION INDICATOR

< DTC/CIRCUIT DIAGNOSIS >

[5AT: RE5R05A]

12. CHECK SHIFT POSITION SWITCH

1. Disconnect shift position switch connector.
2. Check continuity between A/T shift selector harness connector terminals and shift position switch connector terminals.

A/T shift selector harness connector		Shift position switch connector		Continuity
Connector	Terminal	Connector	Terminal	
M137	7	M221	10	Existed
			2, 3, 4, 5, 6, 7, 9, 11	No existed
	9		11	Existed
			2, 3, 4, 5, 6, 7, 9, 10	No existed

Is the inspection result normal?

YES >> GO TO 13.

NO >> Repair or replace damaged parts. Refer to [TM-157, "2WD : Exploded View"](#) (2WD), [TM-160, "AWD : Exploded View"](#) (AWD).

13. CHECK HARNESS BETWEEN SHIFT POSITION SWITCH AND SELECTOR LEVER POSITION INDICATOR (PART 1)

1. Disconnect selector lever position indicator connector.
2. Check continuity between shift position switch harness connector terminals and selector lever position indicator connector terminals.

Shift position switch harness connector		Selector lever position indicator harness connector		Continuity
Connector	Terminal	Connector	Terminal	
M221	10	M223	1	Existed
	11		9	

Is the inspection result normal?

YES >> GO TO 14.

NO >> Repair or replace damaged parts. Refer to [TM-157, "2WD : Exploded View"](#) (2WD), [TM-160, "AWD : Exploded View"](#) (AWD).

14. CHECK HARNESS BETWEEN SHIFT POSITION SWITCH AND SELECTOR LEVER POSITION INDICATOR (PART 2)

Check harness cladding between shift position switch connector and selector lever position indicator connector for damage.

Is the inspection result normal?

YES >> GO TO 10.

NO >> Repair or replace damaged parts. Refer to [TM-157, "2WD : Exploded View"](#) (2WD), [TM-160, "AWD : Exploded View"](#) (AWD).

Component Inspection

INFOID:000000004342980

1. CHECK SELECTOR LEVER POSITION INDICATOR

Check that selector lever position indicator lamps turn on.

CAUTION:

Connect the fuse between the terminals when applying the voltage.

SELECTOR LEVER POSITION INDICATOR

< DTC/CIRCUIT DIAGNOSIS >

[5AT: RE5R05A]

Selector lever position indicator connector		Condition	Status	
Connector	Terminal			
	+ (fuse)			-
M223	3	8	Apply 12 V direct current between terminals 3 and 8. "N" position indicator lamp turns on.	
	4		Apply 12 V direct current between terminals 4 and 8. "D" position indicator lamp turns on.	
	5		Apply 12 V direct current between terminals 5 and 8. "R" position indicator lamp turns on.	
	7		Apply 12 V direct current between terminals 7 and 8. "P" position indicator lamp turns on.	
	6	2	Apply 12 V direct current between terminals 6 and 2. "M" mode indicator lamp turns on.	
	1	9	Apply 12 V direct current between terminals 1 and 9. Illumination lamp turns on.	

Is the inspection result normal?

YES >> INSPECTION END

NO >> Replace the selector lever position indicator. Refer to [TM-157, "2WD : Exploded View"](#) (2WD), [TM-160, "AWD : Exploded View"](#) (AWD).

ECU DIAGNOSIS INFORMATION

TCM

Reference Value

INFOID:000000004342981

VALUES ON DIAGNOSIS TOOL

NOTE:

- The CONSULT-III electrically displays shift timing and lock-up timing (that is, operation timing of each solenoid).
Check for time difference between actual shift timing and the CONSULT-III display. If the difference is noticeable, mechanical parts (except solenoids, sensors, etc.) may be malfunctioning. Check mechanical parts using applicable diagnostic procedures.
- Shift schedule (which implies gear position) displayed on CONSULT-III and that indicated in Service Manual may differ slightly. This occurs because of the following reasons:
 - Actual shift schedule has more or less tolerance or allowance
 - Shift schedule indicated in Service Manual refers to the point where shifts start
 - Gear position displayed on CONSULT-III indicates the point where shifts are completed
- Display of solenoid valves on CONSULT-III changes at the start of shifting, while gear position is displayed upon completion of shifting (which is computed by TCM).

CONSULT-III MONITOR ITEM

Item name	Condition	Value / Status (Approx.)
VHCL/S SE-A/T	During driving	Approximately matches the speedometer reading.
VHCL/S SE-MTR	During driving	Approximately matches the speedometer reading.
ACCELE POSI	Released accelerator pedal.	0.0/8
	Fully depressed accelerator pedal.	8.0/8
CLSD THL POS	Released accelerator pedal.	On
	Fully depressed accelerator pedal.	Off
W/O THL POS	Fully depressed accelerator pedal.	On
	Released accelerator pedal.	Off
BRAKE SW	Depressed brake pedal.	On
	Released brake pedal.	Off
GEAR	During driving	1, 2, 3, 4, 5
ENGINE SPEED	Engine running	Closely matches the tachometer reading.
INPUT SPEED	During driving (lock-up ON)	Approximately matches the engine speed.
ATF TEMP SE 1	0°C (32° F) – 20°C (68°F) – 80°C (176°F)	3.3 – 2.7 – 0.9 V
ATF TEMP SE 2	0°C (32° F) – 20°C (68°F) – 80°C (176°F)	3.3 – 2.5 – 0.7 V
ATF TEMP 1	Ignition switch ON	Temperature of ATF in the oil pan is indicated.
ATF PRES SW 2	Low coast brake engaged. Refer to TM-21 .	On
	Low coast brake disengaged. Refer to TM-21 .	Off

TCM

< ECU DIAGNOSIS INFORMATION >

[5AT: RE5R05A]

Item name	Condition	Value / Status (Approx.)
SLCT LVR POSI	Selector lever in "N" and "P" positions	N/P
	Selector lever in "R" position	R
	Selector lever in "D" position	D
	Selector lever in "M" position: 5GR	D
	Selector lever in "M" position: 4GR	4
	Selector lever in "M" position: 3GR	3
	Selector lever in "M" position: 2GR	2
	Selector lever in "M" position: 1GR	1
MANU MODE SW	Selector lever is shifted to manual shift gate side	On
	Other than the above	Off
NON M-MODE SW	Selector lever is shifted to manual shift gate side	Off
	Other than the above	On
UP SW LEVER	Selector lever is shifted to + side	On
	Other than the above	Off
DOWN SW LEVER	Selector lever is shifted to – side	On
	Other than the above	Off
TCC SOLENOID	Slip lock-up is active	0.2 – 0.4 A
	Lock-up is active	0.4 – 0.6 A
	Other than the above	0 – 0.05 A
LINE PRES SOL	During driving	0.2 – 0.6 A
FR/B SOLENOID	Front brake engaged. Refer to TM-21 .	0.6 – 0.8 A
	Front brake disengaged. Refer to TM-21 .	0 – 0.05 A
I/C SOLENOID	Input clutch disengaged. Refer to TM-21 .	0.6 – 0.8 A
	Input clutch engaged. Refer to TM-21 .	0 – 0.05 A
D/C SOLENOID	Direct clutch disengaged. Refer to TM-21 .	0.6 – 0.8 A
	Direct clutch engaged. Refer to TM-21 .	0 – 0.05 A
HLR/C SOL	High and low reverse clutch disengaged. Refer to TM-21 .	0.6 – 0.8 A
	High and low reverse clutch engaged. Refer to TM-21 .	0 – 0.05 A
ON OFF SOL	Low coast brake engaged. Refer to TM-21 .	On
	Low coast brake disengaged. Refer to TM-21 .	Off
STARTER RELAY	Selector lever in "N" and "P" positions.	On
	Selector lever in "R" and "D" positions.	Off
VEHICLE SPEED	During driving	Approximately matches the speedometer reading.

TERMINAL LAYOUT

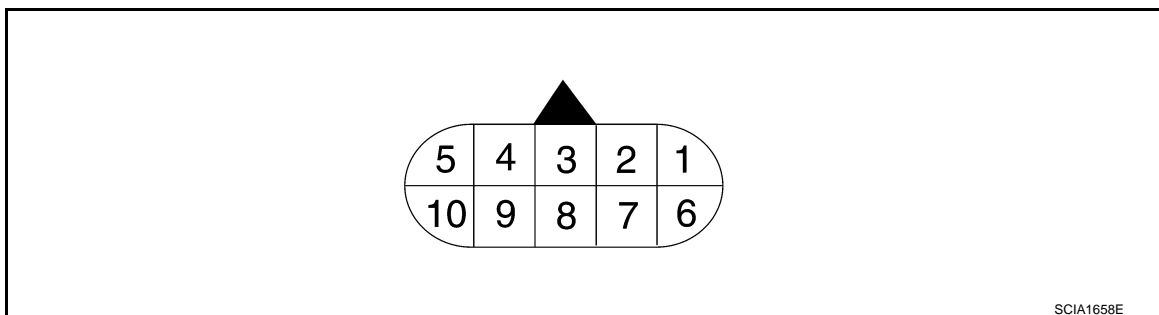

TCM

< ECU DIAGNOSIS INFORMATION >

[5AT: RE5R05A]

PHYSICAL VALUES

Terminal (Wire color)		Description		Condition	Value (Approx.)
+	-	Signal name	Input/ Output		
1 (BR)	Ground	Power supply (Memory back-up)	Input	Always	Battery voltage
2 (BR)	Ground	Power supply (Memory back-up)	Input	Always	Battery voltage
3 (L)	—	CAN-H	Input/ Output	—	—
4 (V)	—	K-line (CONSULT-III signal)	Input/ Output	—	—
5 (B)	Ground	Ground	Output	Always	0 V
6 (Y)	Ground	Power supply	Input	Ignition switch ON	Battery voltage
				Ignition switch OFF	0 V
7 (R)	Ground	Back-up lamp relay	Input	Ignition switch ON	Selector lever in "R" position.
					Selector lever in other positions.
8 (P)	—	CAN-L	Input/ Output	—	—
9 (GR)	Ground	Starter relay	Output	Ignition switch ON	Selector lever in "N" and "P" positions.
					Selector lever in other positions.
10 (B)	Ground	Ground	Output	Always	0 V

A
B
C
TM
E
F
G
H
I
J
K
L
M
N
O
P

Wiring Diagram - A/T CONTROL SYSTEM -

INFOID:000000004342982

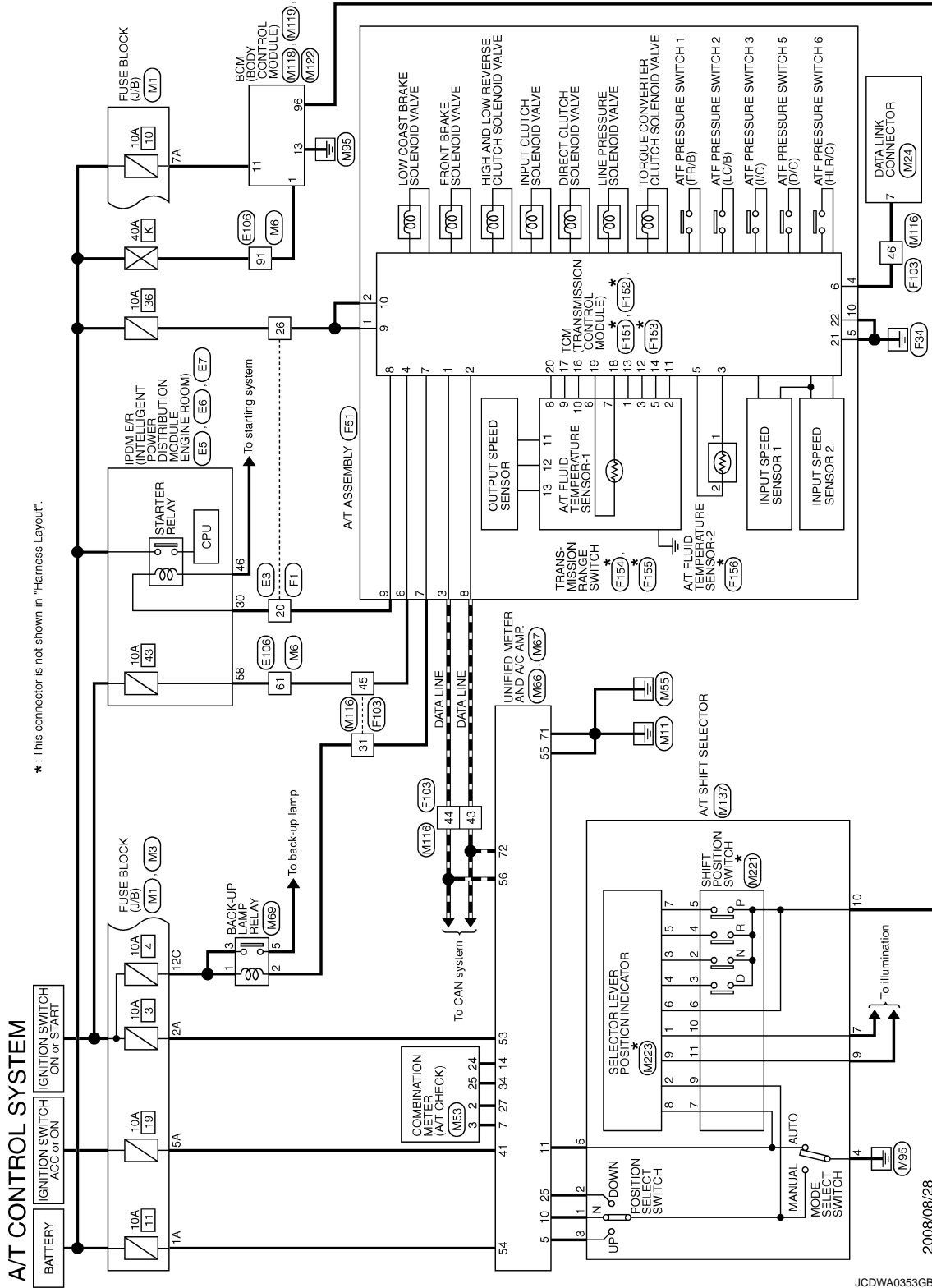

*: This connector is not shown in "Harness Layout".

A/T CONTROL SYSTEM

Connector No.	E3
Connector Name	WIRE TO WIRE
Connector Type	SAA38MB-RS10-SJZZ

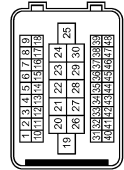

Terminal No.	Color of Wire	Signal Name [Specification]
20	GR	-
26	R	-

Connector No.	E5
Connector Name	EDM E/R (INTELLIGENT POWER DISTRIBUTION MODULE ENGINE ROOM)
Connector Type	TH20FW-CS12-M4-1V



Terminal No.	Color of Wire	Signal Name [Specification]
30	GR	-

Connector No.	E6
Connector Name	EDM E/R (INTELLIGENT POWER DISTRIBUTION MODULE ENGINE ROOM)
Connector Type	TR08FW-NH

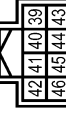

Terminal No.	Color of Wire	Signal Name [Specification]
46	R	-

Connector No.	E7
Connector Name	EDM E/R (INTELLIGENT POWER DISTRIBUTION MODULE ENGINE ROOM)
Connector Type	TH20FW-CS12-M4



Terminal No.	Color of Wire	Signal Name [Specification]
58	P	-

Connector No.	E108
Connector Name	WIRE TO WIRE
Connector Type	TH00FW-CS16-TM4

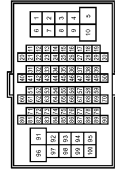

Terminal No.	Color of Wire	Signal Name [Specification]
61	P	-
91	W	-

Connector No.	F1
Connector Name	WIRE TO WIRE
Connector Type	SAA38FB-RS10-SJZZ

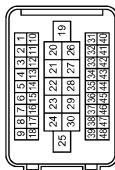

Terminal No.	Color of Wire	Signal Name [Specification]
20	GR	-
26	BR	-

Connector No.	F51
Connector Name	A/T ASSEMBLY
Connector Type	RK10FG-DGY

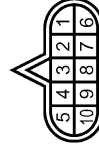

Terminal No.	Color of Wire	Signal Name [Specification]
1	BR	-
2	BR	-
3	L	-
4	V	-
5	B	-
6	V	-
7	R	-
8	P	-
9	GR	-
10	B	-

Connector No.	F103
Connector Name	WIRE TO WIRE
Connector Type	TR08FW-NS10

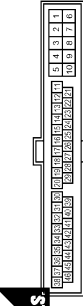

Terminal No.	Color of Wire	Signal Name [Specification]
31	R	-
43	P	-
44	L	-
45	Y	-
46	V	-

JCDWA0354GB

A
B
C
TM
E
F
G
H
I
J
K
L
M
N
O
P

A/T CONTROL SYSTEM

Connector No.	F154
Connector Name	TRANSMISSION RANGE SWITCH
Connector Type	SPI0FEGY

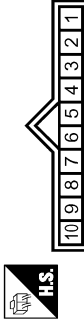

Terminal No.	Color of Wire	Signal Name [Specification]
1	BR	S1
2	W	S4
3	GR	S2
5	L	S3
6	G	-
7	O	-
8	Y	C1
9	R	C2
10	B	C3

Connector No.	F153
Connector Name	TCM (TRANSMISSION CONTROL MODULE)
Connector Type	SPO2F



Terminal No.	Color of Wire	Signal Name [Specification]
21	B	POWER GND-1
22	Y	POWER GND-2

Connector No.	F152
Connector Name	TCM (TRANSMISSION CONTROL MODULE)
Connector Type	SPI0FAG



Terminal No.	Color of Wire	Signal Name [Specification]
11	W	INH-SW4
12	GR	INH-SW2
13	BR	INH-SW1
14	L	INH-SW3
16	B	REV SEN GND
17	R	REV SEN VOUT
18	O	ATF SNS1-
19	G	ATF SNS1+
20	Y	REV SEN VIN

Connector No.	F151
Connector Name	TCM (TRANSMISSION CONTROL MODULE)
Connector Type	SPI0FEGY



Terminal No.	Color of Wire	Signal Name [Specification]
1	BR	CAN-H
2	L/Y	CAN-L
3	W/L	ATF SEN2-
4	R	VIGN
5	W/R	ATF SEN2+
6	L	K LINE
7	O	REV LAMP RLY
8	G	START RLY
9	W	STANDBY SUPPLY-1
10	GR	STANDBY SUPPLY-2

Connector No.	M3
Connector Name	FUSE BLOCK (J/B)
Connector Type	NS12FW-CS



Connector No.	M1
Connector Name	FUSE BLOCK (J/B)
Connector Type	NS68FW-M2



Connector No.	F156
Connector Name	A/T FLUID TEMPERATURE SENSOR-2
Connector Type	SPO2F



Terminal No.	Color of Wire	Signal Name [Specification]
12C	O	-

Terminal No.	Color of Wire	Signal Name [Specification]
1A	GR	-
2A	G	-
5A	V	-
7A	R	-

Terminal No.	Color of Wire	Signal Name [Specification]
1	W/L	-
2	W/R	-

Connector No.	F155
Connector Name	TRANSMISSION RANGE SWITCH
Connector Type	A03FW



Terminal No.	Color of Wire	Signal Name [Specification]
11	L	GND
12	W	VOUT
13	R	VCC

JCDWA0355GB

A/T CONTROL SYSTEM

Connector No.	M86
Connector Name	WIRE TO WIRE
Connector Type	TH38FW-NH

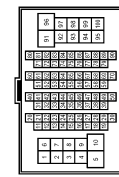

Terminal No.	Color of Wire	Signal Name [Specification]
61	BR	-
91	W	-

Connector No.	M24
Connector Name	DATA LINK CONNECTOR
Connector Type	BD1BFV

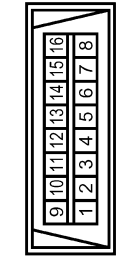

Terminal No.	Color of Wire	Signal Name [Specification]
7	V	-

Connector No.	M53
Connector Name	COMBINATION METER
Connector Type	TH46FW-NH

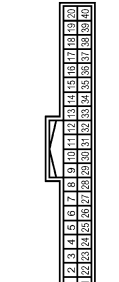

Terminal No.	Color of Wire	Signal Name [Specification]
2	LG	COMM (METER->AMP.)
3	GR	COMM (AMP->METER)
24	BR	COMM (LGD->AMP.)
25	Y	COMM (AMP->LGD)

Connector No.	M66
Connector Name	UNIFIED METER AND A/C AMP.
Connector Type	TH46FW-NH

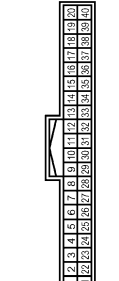

Terminal No.	Color of Wire	Signal Name [Specification]
5	L	SHIFT UP
7	GR	COMMUNICATION SIGNAL (AMP->METER)
10	W	MANUAL MODE
11	G	NOT MANUAL MODE
14	BR	COMMUNICATION SIGNAL (LGD->AMP.)
25	V	SHIFT DOWN
27	LG	COMMUNICATION SIGNAL (METER->AMP.)
34	Y	COMMUNICATION SIGNAL (AMP->LGD)

Connector No.	M87
Connector Name	UNIFIED METER AND A/C AMP.
Connector Type	TH32FW-NH

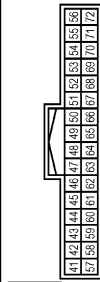

Terminal No.	Color of Wire	Signal Name [Specification]
41	V	ACC POWER SUPPLY
53	G	IGNITION POWER SUPPLY
54	Y	BATTERY POWER SUPPLY
55	B	GROUND
56	L	CAN-H
71	B	GROUND
72	P	CAN-L

Connector No.	M69
Connector Name	BACK-UP LAMP RELAY
Connector Type	MS2FL-M2-LC

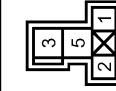

Terminal No.	Color of Wire	Signal Name [Specification]
1	R	-
2	W	-
3	LG	-
5	O	-

Connector No.	M116
Connector Name	WIRE TO WIRE
Connector Type	TK38MW-MS10

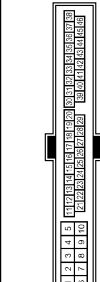

Terminal No.	Color of Wire	Signal Name [Specification]
31	W	-
43	P	-
44	L	-
45	BR	-
46	O	-

Connector No.	M118
Connector Name	BCM (BODY CONTROL MODULE)
Connector Type	MS2FB-LC



Terminal No.	Color of Wire	Signal Name [Specification]
1	W	BAT.(F/L)

A
B
C
TM
E
F
G
H
I
J
K
L
M
N
O
P

A/T CONTROL SYSTEM

Connector No.	M119
Connector Name	BCM (BODY CONTROL MODULE)
Connector Type	NSI (RFW-GS)



Terminal No.	Color of Wire	Signal Name [Specification]
11	R	BAT FUSE
13	B	GND

Connector No.	M122
Connector Name	BCM (BODY CONTROL MODULE)
Connector Type	TH40FB-NH

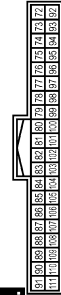

Terminal No.	Color of Wire	Signal Name [Specification]
96	GR	A/T-SHIFT SELECTOR POWER SUPPLY

Connector No.	M137
Connector Name	A/T-SHIFT SELECTOR
Connector Type	TH12FW-NH

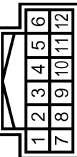

Terminal No.	Color of Wire	Signal Name [Specification]
1	W	-
2	V	-
3	L	-
4	B	-
5	G	-
7	R	-
9	B	-
10	GR	-

Connector No.	M221
Connector Name	SHIFT POSITION SWITCH
Connector Type	TH12FW

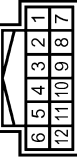

Terminal No.	Color of Wire	Signal Name [Specification]
2	L	N
3	BR	D
4	G	R
5	P	P
6	V	M
7	O	AT
9	Y	MT
10	R	ILL
11	B	GND

Connector No.	M223
Connector Name	SELECTOR LEVER POSITION INDICATOR
Connector Type	XARP-03V



Terminal No.	Color of Wire	Signal Name [Specification]
1	R	ILL
2	Y	MT
3	L	N
4	BR	D
5	G	R
6	V	M
7	P	P
8	O	AT
9	B	GND

JCDWA0357GB

INFOID:000000004342983

Fail-Safe

The TCM has an electrical fail-safe mode. This mode makes it possible to operate even if there is an error in a main electronic control input/output signal circuit.

In fail-safe mode, even if the selector lever is in "D" or "M" mode, the A/T is fixed in 2GR, 4GR and 5GR (depending on the breakdown position), so the customer should feel "slipping" or "poor acceleration".

Even when the electronic circuits are normal, under special conditions (for example, when slamming on the brake with the wheels spinning markedly and stopping the tire rotation), the A/T can go into fail-safe mode. If

this happens, switch OFF the ignition switch for 10 seconds. Then switch it ON again to return to the normal shift pattern. When the customer's vehicle has returned to normal, handle according to the "Work Flow" (Refer to [TM-5. "Work Flow"](#)).

FAIL-SAFE FUNCTION

If any malfunction occurs in a sensor or solenoid, this function controls the A/T to make driving possible.

Output Speed Sensor

Signals are input from two systems - from output speed sensor installed on the A/T and from unified meter and A/C amp. so normal driving is possible even if there is a malfunction in one of the systems. If output speed sensor has unusual cases, 5GR and manual mode are prohibited.

Accelerator Pedal Position Sensor

If there is a malfunction in one of the systems, the accelerator opening angle is controlled by ECM according to a pre-determined accelerator angle to make driving possible. If there are malfunctions in tow systems, the engine speed is fixed by ECM to a pre-determined engine speed to make driving possible.

Throttle Position Sensor

If there is a malfunction in one of the systems, the accelerator opening angle is controlled by ECM according to a pre-determined accelerator angle to make driving possible. If there are malfunctions in tow systems, the accelerator opening angle is controlled by the idle signal transmitted from the ECM which is based on input indicating either idle condition or off-idle condition (pre-determined accelerator opening) in order to make driving possible.

Transmission Range Switch

In the unlikely event that a malfunction signal enters the TCM, the position indicator is switched OFF, the starter relay is switched OFF (starter is disabled), the back-up lamp relay switched OFF (back-up lamp is OFF) and the position is fixed to the "D" position to make driving possible.

Starter Relay

The starter relay is switched OFF. (Starter is disabled.)

Interlock

- If there is an interlock judgment malfunction, the A/T is fixed in 2GR to make driving possible.

NOTE:

When the vehicle is driven fixed in 2GR, a input speed sensor malfunction is displayed, but this is not a input speed sensor malfunction.

- When interlock is detected at the 3GR or more, it is locked at the 2GR.

1st Engine Braking

When there is an A/T 1st engine brake judgment malfunction, the low coast brake solenoid is switched OFF to avoid the engine brake operation.

Line Pressure Solenoid

The solenoid is switched OFF and the line pressure is set to the maximum hydraulic pressure to make driving possible.

Torque Converter Clutch Solenoid

The solenoid is switched OFF to release the lock-up.

Low Coast Brake Solenoid

When a malfunction (electrical or functional) occurs, in order to make driving possible. If the solenoid is ON, the A/T is held in 2GR. If the solenoid is OFF, the A/T is held in 4GR. (Engine brake is not applied in 1GR and 2GR.)

Input Clutch Solenoid

If a malfunction (electrical or functional) occurs with the solenoid either ON or OFF, the A/T is held in 4GR to make driving possible.

Direct Clutch Solenoid

If a malfunction (electrical or functional) occurs with the solenoid either ON or OFF, the A/T is held in 4GR to make driving possible.

Front Brake Solenoid

If a malfunction (electrical or functional) occurs with the solenoid ON, in order to make driving possible. The A/T is held in 5GR. If the solenoid is OFF, the A/T is in 4GR.

High and Low Reverse Clutch Solenoid

TCM

< ECU DIAGNOSIS INFORMATION >

[5AT: RE5R05A]

If a (electrical or functional) malfunction occurs with the solenoid either ON or OFF, the A/T is held in 4GR to make driving possible.

Input Speed Sensor 1 or 2

The control is the same as if there were no input speed sensors, 5GR and manual mode are prohibited.

DTC Inspection Priority Chart

INFOID:000000004342984

If some DTCs are displayed at the same time, perform inspections one by one based on the following priority chart.

NOTE:

If DTC "U1000" is displayed with other DTC, first perform the trouble diagnosis for "DTC U1000 CAN COMM CIRCUIT". Refer to [TM-45, "Description"](#).

Priority	Detected items (DTC)
1	U1000 CAN COMM CIRCUIT
2	Except above

DTC Index

INFOID:000000004342985

NOTE:

If DTC "U1000" is displayed with other DTC, first perform the trouble diagnosis for "DTC U1000 CAN COMM CIRCUIT". Refer to [TM-45, "Description"](#).

DTC ²		Items (CONSULT-III screen terms)	Reference
MIL ¹ , "ENGINE" with CONSULT-III or GST	CONSULT-III only "TRANSMISSION"		
—	P0615	STARTER RELAY	TM-46
P0700	P0700	TORQUE CONVERTER	TM-48
P0705	P0705	T/M RANGE SWITCH A	TM-49
P0710	P1710	FLUID TEMP SENSOR	TM-71
P0717	P0717	INPUT SPEED SENSOR A	TM-51
P0720	P0720	OUTPUT SPEED SENSOR	TM-52
—	P0725	ENGINE SPEED	TM-55
P0731	P0731	1GR INCORRECT RATIO	TM-57
P0732	P0732	2GR INCORRECT RATIO	TM-59
P0733	P0733	3GR INCORRECT RATIO	TM-61
P0734	P0734	4GR INCORRECT RATIO	TM-63
P0735	P0735	5GR INCORRECT RATIO	TM-65
P0740	P0740	TORQUE CONVERTER	TM-67
P0744	P0744	TORQUE CONVERTER	TM-68
P0745	P0745	PC SOLENOID A	TM-69
—	P1705	TP SENSOR	TM-70
—	P1721	VEHICLE SPEED SIGNAL	TM-74
P1730	P1730	INTERLOCK	TM-75
—	P1731	1ST E/BRAKING	TM-76
P1752	P1752	INPUT CLUTCH SOLENOID	TM-77
P1757	P1757	FR BRAKE SOLENOID	TM-78
P1762	P1762	DRCT CLUTCH SOLENOID	TM-79
P1767	P1767	HLR CLUTCH SOLENOID	TM-80
P1772	P1772	L C BRAKE SOLENOID	TM-81

TCM

< ECU DIAGNOSIS INFORMATION >

[5AT: RE5R05A]

DTC*2		Items (CONSULT-III screen terms)	Reference
MIL*1, "ENGINE" with CONSULT-III or GST	CONSULT-III only "TRANSMIS- SION"		
P1774	P1774	L C BRAKE SOLENOID	TM-82
—	P1815	M-MODE SWITCH	TM-84
U1000	U1000	CAN COMM CIRCUIT	TM-45

*1: Refer to [TM-36. "Diagnosis Description"](#).

*2: These numbers are prescribed by SAE J2012.

A
B
C

E
F
G
H
I
J
K
L
M
N
O
P

TM

SYSTEM SYMPTOM

< SYMPTOM DIAGNOSIS >

[5AT: RE5R05A]

SYMPTOM DIAGNOSIS

SYSTEM SYMPTOM

Symptom Table

INFOID:000000004342986

The diagnostics item numbers show the sequence for inspection. Inspect in order from item 1.

No.	Item	Symptom	Condition	Diagnostic item	Reference
1	Shift Shock	Large shock. ("N" → "D" position)	ON vehicle	1. Engine idle speed	EC-17
				2. Engine speed signal	TM-55
				3. Accelerator pedal position sensor	TM-70
				4. A/T position	TM-155 (2WD), TM-155 (AWD)
				5. A/T fluid temperature sensor	TM-71
				6. Front brake solenoid valve	TM-78
				7. CAN communication line	TM-45
				8. A/T fluid leakage	—
				9. Line pressure test	TM-149
				10. Control valve with TCM	TM-165
			OFF vehicle	11. Forward brake (Parts behind drum support is impossible to perform inspection by disassembly. Refer to TM-19 , " Cross-Sectional View ").	TM-211
2		Shock is too large when changing D1 → D2 or M1 → M2.	ON vehicle	1. Accelerator pedal position sensor	TM-70
				2. A/T position	TM-155 (2WD), TM-155 (AWD)
				3. Direct clutch solenoid valve	TM-79
				4. CAN communication line	TM-45
				5. Engine speed signal	TM-55
				6. Input speed sensor	TM-51
				7. Output speed sensor and vehicle speed signal	TM-52 , TM-74
				8. A/T fluid leakage	—
				9. Control valve with TCM	TM-165
			OFF vehicle	10. Direct clutch	TM-270

SYSTEM SYMPTOM

< SYMPTOM DIAGNOSIS >

[5AT: RE5R05A]

No.	Item	Symptom	Condition	Diagnostic item	Reference
3		Shock is too large when changing D2→D3 or M2 → M3.	ON vehicle	1. Accelerator pedal position sensor	TM-70
				2. A/T position	TM-155 (2WD), TM-155 (AWD)
				3. High and low reverse clutch solenoid valve	TM-80
				4. CAN communication line	TM-45
				5. Engine speed signal	TM-55
				6. Input speed sensor	TM-51
				7. Output speed sensor and vehicle speed signal	TM-52 , TM-74
				8. A/T fluid leakage	—
				9. Control valve with TCM	TM-165
			OFF vehicle	10. High and low reverse clutch	TM-268
4	Shift Shock	Shock is too large when changing D3→D4 or M3 → M4.	ON vehicle	1. Accelerator pedal position sensor	TM-70
				2. A/T position	TM-155 (2WD), TM-155 (AWD)
				3. Input clutch solenoid valve	TM-77
				4. CAN communication line	TM-45
				5. Engine speed signal	TM-55
				6. Input speed sensor	TM-51
				7. Output speed sensor and vehicle speed signal	TM-52 , TM-74
				8. A/T fluid leakage	—
				9. Control valve with TCM	TM-165
			OFF vehicle	10. Input clutch	TM-258
5		Shock is too large when changing D4→D5 or M4 → M5.	ON vehicle	1. Accelerator pedal position sensor	TM-70
				2. A/T position	TM-155 (2WD), TM-155 (AWD)
				3. Front brake solenoid valve	TM-78
				4. CAN communication line	TM-45
				5. Engine speed signal	TM-55
				6. Input speed sensor	TM-51
				7. Output speed sensor and vehicle speed signal	TM-52 , TM-74
				8. A/T fluid leakage	—
				9. Control valve with TCM	TM-165
			OFF vehicle	10. Front brake (brake band)	TM-201
				11. Input clutch	TM-258

A
B
C
TM
E
F
G
H
I
J
K
L
M
N
O
P

SYSTEM SYMPTOM

< SYMPTOM DIAGNOSIS >

[5AT: RE5R05A]

No.	Item	Symptom	Condition	Diagnostic item	Reference
6	Shift Shock	Shock is too large for downshift when accelerator pedal is depressed.	ON vehicle	1. Accelerator pedal position sensor	TM-70
				2. A/T position	TM-155 (2WD), TM-155 (AWD)
				3. CAN communication line	TM-45
				4. Engine speed signal	TM-55
				5. Input speed sensor	TM-51
				6. Output speed sensor and vehicle speed signal	TM-52 , TM-74
				7. A/T fluid leakage	—
				8. Control valve with TCM	TM-165
			OFF vehicle	9. Front brake (brake band)	TM-201
				10. Input clutch	TM-258
				11. High and low reverse clutch	TM-268
				12. Direct clutch	TM-270
7	Shift Shock	Shock is too large for upshift when accelerator pedal is released.	ON vehicle	1. Accelerator pedal position sensor	TM-70
				2. A/T position	TM-155 (2WD), TM-155 (AWD)
				3. Engine speed signal	TM-55
				4. CAN communication line	TM-45
				5. Input speed sensor	TM-51
				6. Output speed sensor and vehicle speed signal	TM-52 , TM-74
				7. A/T fluid leakage	—
				8. Control valve with TCM	TM-165
			OFF vehicle	9. Front brake (brake band)	TM-201
				10. Input clutch	TM-258
				11. High and low reverse clutch	TM-268
				12. Direct clutch	TM-270

SYSTEM SYMPTOM

< SYMPTOM DIAGNOSIS >

[5AT: RE5R05A]

No.	Item	Symptom	Condition	Diagnostic item	Reference	
8	Shift Shock	Shock is too large for lock-up.	ON vehicle	1. Accelerator pedal position sensor	TM-70	
				2. A/T position	TM-155 (2WD), TM-155 (AWD)	
				3. Engine speed signal	TM-55	
				4. CAN communication line	TM-45	
				5. Input speed sensor	TM-51	
				6. Output speed sensor and vehicle speed signal	TM-52 , TM-74	
				7. Torque converter clutch solenoid valve	TM-67	
				8. A/T fluid leakage	—	
				9. Control valve with TCM	TM-165	
9		Shock is too large during engine brake.	ON vehicle	10. Torque converter	TM-252	
				OFF vehicle	1. Accelerator pedal position sensor	TM-70
					2. A/T position	TM-155 (2WD), TM-155 (AWD)
					3. CAN communication line	TM-45
					4. A/T fluid leakage	—
			5. Control valve with TCM		TM-165	
			OFF vehicle	6. Front brake (brake band)	TM-201	
				7. Input clutch	TM-258	
				8. High and low reverse clutch	TM-268	
9. Direct clutch	TM-270					

A
B
C
TM
E
F
G
H
I
J
K
L
M
N
O
P

SYSTEM SYMPTOM

< SYMPTOM DIAGNOSIS >

[5AT: RE5R05A]

No.	Item	Symptom	Condition	Diagnostic item	Reference
10		Gear does not change from D1 → D2 or from M1 → M2.	ON vehicle	1. A/T fluid leakage	—
				2. Output speed sensor and vehicle speed signal	TM-52 , TM-74
				3. Direct clutch solenoid valve	TM-79
				4. Line pressure test	TM-149
				5. CAN communication line	TM-45
				6. Control valve with TCM	TM-165
			OFF vehicle	7. Direct clutch	TM-270
11		Gear does not change from D2 → D3 or from M2 → M3.	ON vehicle	1. A/T fluid leakage	—
				2. Output speed sensor and vehicle speed signal	TM-52 , TM-74
				3. High and low reverse clutch solenoid valve	TM-80
				4. Line pressure test	TM-149
				5. CAN communication line	TM-45
				6. Control valve with TCM	TM-165
			OFF vehicle	7. High and low reverse clutch	TM-268
12	No Up Shift	Gear does not change from D3 → D4 or from M3 → M4.	ON vehicle	1. A/T fluid leakage	—
				2. Output speed sensor and vehicle speed signal	TM-52 , TM-74
				3. Input clutch solenoid valve	TM-77
				4. Front brake solenoid valve	TM-78
				5. Line pressure test	TM-149
				6. CAN communication line	TM-45
				7. Control valve with TCM	TM-165
OFF vehicle	8. Input clutch	TM-258			
13		Gear does not change from D4 → D5 or from M4 → M5.	ON vehicle	1. A/T fluid leakage	—
				2. Output speed sensor and vehicle speed signal	TM-52 , TM-74
				3. Front brake solenoid valve	TM-78
				4. Direct clutch solenoid valve	TM-79
				5. Input speed sensor	TM-51
				6. Line pressure test	TM-149
				7. CAN communication line	TM-45
				8. Control valve with TCM	TM-165
			OFF vehicle	9. Front brake (brake band)	TM-201
				10. Input clutch	TM-258

SYSTEM SYMPTOM

< SYMPTOM DIAGNOSIS >

[5AT: RE5R05A]

No.	Item	Symptom	Condition	Diagnostic item	Reference	
14	No Down Shift	In "D" or "M" position, does not downshift to 4GR.	ON vehicle	1. A/T fluid leakage	—	A
				2. Output speed sensor and vehicle speed signal	TM-52 , TM-74	B
				3. Front brake solenoid valve	TM-78	C
				4. Direct clutch solenoid valve	TM-79	TM
				5. CAN communication line	TM-45	
				6. Line pressure test	TM-149	
				7. Control valve with TCM	TM-165	
			OFF vehicle	8. Front brake (brake band)	TM-201	
				9. Input clutch	TM-258	
15	No Down Shift	In "D" or "M" position, does not downshift to 3GR.	ON vehicle	1. A/T fluid leakage	—	E
				2. Output speed sensor and vehicle speed signal	TM-52 , TM-74	F
				3. Input clutch solenoid valve	TM-77	G
				4. Front brake solenoid valve	TM-78	H
				5. CAN communication line	TM-45	
				6. Line pressure test	TM-149	
				7. Control valve with TCM	TM-165	
			OFF vehicle	8. Input clutch	TM-258	
16	No Down Shift	In "D" or "M" position, does not downshift to 2GR.	ON vehicle	1. A/T fluid leakage	—	I
				2. Output speed sensor and vehicle speed signal	TM-52 , TM-74	J
				3. High and low reverse clutch solenoid valve	TM-80	K
				4. CAN communication line	TM-45	
				5. Line pressure test	TM-149	
				6. Control valve with TCM	TM-165	
			OFF vehicle	7. High and low reverse clutch	TM-268	
17	No Down Shift	In "D" or "M" position, does not downshift to 1GR.	ON vehicle	1. A/T fluid leakage	—	L
				2. Output speed sensor and vehicle speed signal	TM-52 , TM-74	M
				3. Direct clutch solenoid valve	TM-79	N
				4. CAN communication line	TM-45	
				5. Line pressure test	TM-149	
				6. Control valve with TCM	TM-165	
			OFF vehicle	7. Direct clutch	TM-270	

SYSTEM SYMPTOM

< SYMPTOM DIAGNOSIS >

[5AT: RE5R05A]

No.	Item	Symptom	Condition	Diagnostic item	Reference
18	Slips/Will Not Engage	When "D" or "M" position, remains in 1GR.	ON vehicle	1. A/T fluid leakage	—
				2. Output speed sensor and vehicle speed signal	TM-52 , TM-74
				3. Direct clutch solenoid valve	TM-79
				4. Line pressure test	TM-149
				5. CAN communication line	TM-45
				6. Control valve with TCM	TM-165
			OFF vehicle	7. 3rd one-way clutch	TM-256
				8. 1st one-way clutch	TM-263
				9. Gear system	TM-201
				10. Reverse brake	TM-211
				11. Forward one-way clutch (Parts behind drum support is impossible to perform inspection by disassembly. Refer to TM-19 , " Cross-Sectional View ".)	TM-211
				12. Forward brake (Parts behind drum support is impossible to perform inspection by disassembly. Refer to TM-19 , " Cross-Sectional View ".)	TM-211
19		When "D" or "M" position, remains in 2GR.	ON vehicle	1. A/T fluid leakage	—
				2. Output speed sensor and vehicle speed signal	TM-52 , TM-74
				3. Low coast brake solenoid valve	TM-81
				4. Line pressure test	TM-149
				5. CAN communication line	TM-45
				6. Control valve with TCM	TM-165
			OFF vehicle	7. 3rd one-way clutch	TM-256
				8. Gear system	TM-201
				9. Direct clutch	TM-270
				10. Forward brake (Parts behind drum support is impossible to perform inspection by disassembly. Refer to TM-19 , " Cross-Sectional View ".)	TM-211

SYSTEM SYMPTOM

< SYMPTOM DIAGNOSIS >

[5AT: RE5R05A]

No.	Item	Symptom	Condition	Diagnostic item	Reference
20		When "D" or "M" position, remains in 3GR.	ON vehicle	1. A/T fluid leakage	—
				2. Output speed sensor and vehicle speed signal	TM-52 , TM-74
				3. Line pressure test	TM-149
				4. CAN communication line	TM-45
				5. Control valve with TCM	TM-165
			OFF vehicle	6. 3rd one-way clutch	TM-256
				7. Gear system	TM-201
				8. High and low reverse clutch	TM-268
				9. Forward one-way clutch (Parts behind drum support is impossible to perform inspection by disassembly. Refer to TM-19 , " Cross-Sectional View ".)	TM-211
				10. Forward brake (Parts behind drum support is impossible to perform inspection by disassembly. Refer to TM-19 , " Cross-Sectional View ".)	TM-211
21	Slips/Will Not Engage	When "D" or "M" position, remains in 4GR.	ON vehicle	1. A/T fluid leakage	—
				2. Output speed sensor and vehicle speed signal	TM-52 , TM-74
				3. Input clutch solenoid valve	TM-77
				4. Direct clutch solenoid valve	TM-79
				5. High and low reverse clutch solenoid valve	TM-80
				6. Low coast brake solenoid valve	TM-81
				7. Front brake solenoid valve	TM-78
				8. Line pressure test	TM-149
				9. CAN communication line	TM-45
				10. Control valve with TCM	TM-165
			OFF vehicle	11. Input clutch	TM-258
				12. Gear system	TM-201
				13. High and low reverse clutch	TM-268
				14. Direct clutch	TM-270
22		When "D" or "M" position, remains in 5GR.	ON vehicle	1. A/T fluid leakage	—
				2. Output speed sensor and vehicle speed signal	TM-52 , TM-74
				3. Front brake solenoid valve	TM-78
				4. Line pressure test	TM-149
				5. CAN communication line	TM-45
				6. Control valve with TCM	TM-165
			OFF vehicle	7. Front brake (brake band)	TM-201
				8. Input clutch	TM-258
				9. Gear system	TM-201
				10. High and low reverse clutch	TM-268

A
B
C
TM
E
F
G
H
I
J
K
L
M
N
O
P

SYSTEM SYMPTOM

< SYMPTOM DIAGNOSIS >

[5AT: RE5R05A]

No.	Item	Symptom	Condition	Diagnostic item	Reference				
23		Vehicle cannot take off from D1.	ON vehicle	1. A/T fluid leakage	—				
				2. Accelerator pedal position sensor	TM-70				
				3. Line pressure test	TM-149				
				4. CAN communication line	TM-45				
				5. Control valve with TCM	TM-165				
			OFF vehicle	6. Torque converter	TM-252				
				7. Oil pump assembly	TM-253				
				8. 3rd one-way clutch	TM-256				
				9. 1st one-way clutch	TM-263				
				10. Gear system	TM-201				
				11. Reverse brake	TM-211				
				12. Forward one-way clutch (Parts behind drum support is impossible to perform inspection by disassembly. Refer to TM-19 , " Cross-Sectional View ".)	TM-211				
				13. Forward brake (Parts behind drum support is impossible to perform inspection by disassembly. Refer to TM-19 , " Cross-Sectional View ".)	TM-211				
24	Slips/Will Not Engage	Does not lock-up.	ON vehicle	1. A/T fluid leakage	—				
				2. Line pressure test	TM-149				
				3. Engine speed signal	TM-55				
				4. Input speed sensor	TM-51				
				5. Torque converter clutch solenoid valve	TM-67				
				6. CAN communication line	TM-45				
				7. Control valve with TCM	TM-165				
			OFF vehicle	8. Torque converter	TM-252				
				9. Oil pump assembly	TM-253				
				25		Does not hold lock-up condition.	ON vehicle	1. A/T fluid leakage	—
								2. Line pressure test	TM-149
								3. Engine speed signal	TM-55
								4. Input speed sensor	TM-51
5. Torque converter clutch solenoid valve	TM-252								
6. CAN communication line	TM-45								
7. Control valve with TCM	TM-165								
OFF vehicle	8. Torque converter	TM-252							
	9. Oil pump assembly	TM-253							

SYSTEM SYMPTOM

< SYMPTOM DIAGNOSIS >

[5AT: RE5R05A]

No.	Item	Symptom	Condition	Diagnostic item	Reference
26		Lock-up is not released.	ON vehicle	1. A/T fluid leakage	—
				2. Line pressure test	TM-149
				3. Engine speed signal	TM-55
				4. Input speed sensor	TM-51
				5. Torque converter clutch solenoid valve	TM-67
				6. CAN communication line	TM-45
				7. Control valve with TCM	TM-165
			OFF vehicle	8. Torque converter	TM-252
				9. Oil pump assembly	TM-253
27	Slips/Will Not Engage	No shock at all or the clutch slips when vehicle changes speed D1 → D2 or M1 → M2.	ON vehicle	1. A/T fluid leakage	—
				2. Output speed sensor and vehicle speed signal	TM-52 , TM-74
				3. Direct clutch solenoid valve	TM-79
				4. CAN communication line	TM-45
				5. Line pressure test	TM-149
				6. Control valve with TCM	TM-165
			OFF vehicle	7. Torque converter	TM-252
				8. Oil pump assembly	TM-253
				9. 3rd one-way clutch	TM-256
				10. Gear system	TM-201
				11. Direct clutch	TM-270
				12. Forward brake (Parts behind drum support is impossible to perform inspection by disassembly. Refer to TM-19 , " Cross-Sectional View ".)	TM-211
28		No shock at all or the clutch slips when vehicle changes speed D2 → D3 or M2 → M3.	ON vehicle	1. A/T fluid leakage	—
				2. Output speed sensor and vehicle speed signal	TM-52 , TM-74
				3. High and low reverse clutch solenoid valve	TM-80
				4. CAN communication line	TM-45
				5. Line pressure test	TM-149
				6. Control valve with TCM	TM-165
			OFF vehicle	7. Torque converter	TM-252
				8. Oil pump assembly	TM-253
				9. 3rd one-way clutch	TM-256
				10. Gear system	TM-201
				11. High and low reverse clutch	TM-268
				12. Forward one-way clutch (Parts behind drum support is impossible to perform inspection by disassembly. Refer to TM-19 , " Cross-Sectional View ".)	TM-211
				13. Forward brake (Parts behind drum support is impossible to perform inspection by disassembly. Refer to TM-19 , " Cross-Sectional View ".)	TM-211

A
B
C
TM
E
F
G
H
I
J
K
L
M
N
O
P

SYSTEM SYMPTOM

< SYMPTOM DIAGNOSIS >

[5AT: RE5R05A]

No.	Item	Symptom	Condition	Diagnostic item	Reference
29		No shock at all or the clutch slips when vehicle changes speed D3 → D4 or M3 → M4.	ON vehicle	1. A/T fluid leakage	—
				2. Output speed sensor and vehicle speed signal	TM-52 , TM-74
				3. Input clutch solenoid valve	TM-77
				4. Front brake solenoid valve	TM-78
				5. CAN communication line	TM-45
				6. Line pressure test	TM-149
				7. Control valve with TCM	TM-165
			OFF vehicle	8. Torque converter	TM-252
				9. Oil pump assembly	TM-253
				10. Input clutch	TM-258
				11. Gear system	TM-201
				12. High and low reverse clutch	TM-268
				13. Direct clutch	TM-270
30	Slips/Will Not Engage	No shock at all or the clutch slips when vehicle changes speed D4 → D5 or M4 → M5.	ON vehicle	1. A/T fluid leakage	—
				2. Output speed sensor and vehicle speed signal	TM-52 , TM-74
				3. Front brake solenoid valve	TM-78
				4. Direct clutch solenoid valve	TM-79
				5. CAN communication line	TM-45
				6. Line pressure test	TM-149
				7. Control valve with TCM	TM-165
			OFF vehicle	8. Torque converter	TM-252
				9. Oil pump assembly	TM-253
				10. Front brake (brake band)	TM-201
				11. Input clutch	TM-258
				12. Gear system	TM-201
				13. High and low reverse clutch	TM-268
31		When accelerator pedal is depressed and speed is shifted to D5 → D4 or M5 → M4 the engine idles or the A/T slips.	ON vehicle	1. A/T fluid leakage	—
				2. Output speed sensor and vehicle speed signal	TM-52 , TM-74
				3. Front brake solenoid valve	TM-78
				4. Direct clutch solenoid valve	TM-79
				5. CAN communication line	TM-45
				6. Line pressure test	TM-149
				7. Control valve with TCM	TM-165
			OFF vehicle	8. Torque converter	TM-252
				9. Oil pump assembly	TM-253
				10. Input clutch	TM-258
				11. Gear system	TM-201
				12. High and low reverse clutch	TM-268
				13. Direct clutch	TM-270

SYSTEM SYMPTOM

< SYMPTOM DIAGNOSIS >

[5AT: RE5R05A]

No.	Item	Symptom	Condition	Diagnostic item	Reference
32	Slips/Will Not Engage	When accelerator pedal is depressed and speed is shifted to D4→ D3 or M4 → M3 the engine idles or the A/T slips.	ON vehicle	1. A/T fluid leakage	—
				2. Output speed sensor and vehicle speed signal	TM-52 , TM-74
				3. Input clutch solenoid valve	TM-77
				4. Front brake solenoid valve	TM-78
				5. CAN communication line	TM-45
				6. Line pressure test	TM-149
				7. Control valve with TCM	TM-165
			OFF vehicle	8. Torque converter	TM-252
				9. Oil pump assembly	TM-253
				10. 3rd one-way clutch	TM-256
				11. Gear system	TM-201
				12. High and low reverse clutch	TM-268
				13. Forward one-way clutch (Parts behind drum support is impossible to perform inspection by disassembly. Refer to TM-19 , " Cross-Sectional View ".)	TM-211
				14. Forward brake (Parts behind drum support is impossible to perform inspection by disassembly. Refer to TM-19 , " Cross-Sectional View ".)	TM-211
33		When accelerator pedal is depressed and speed is shifted to D3→ D2 or M3 → M2 the engine idles or the A/T slips.	ON vehicle	1. A/T fluid leakage	—
				2. Output speed sensor and vehicle speed signal	TM-52 , TM-74
				3. High and low reverse clutch solenoid valve	TM-80
				4. Direct clutch solenoid valve	TM-79
				5. CAN communication line	TM-45
				6. Line pressure test	TM-149
				7. Control valve with TCM	TM-165
			OFF vehicle	8. Torque converter	TM-252
				9. Oil pump assembly	TM-253
				10. 3rd one-way clutch	TM-256
				11. Gear system	TM-201
				12. Direct clutch	TM-270
				13. Forward brake (Parts behind drum support is impossible to perform inspection by disassembly. Refer to TM-19 , " Cross-Sectional View ".)	TM-211

A
B
C
TM
E
F
G
H
I
J
K
L
M
N
O
P

SYSTEM SYMPTOM

< SYMPTOM DIAGNOSIS >

[5AT: RE5R05A]

No.	Item	Symptom	Condition	Diagnostic item	Reference
34		When accelerator pedal is depressed and speed is shifted to D2→ D1 or M2 → M1 the engine idles or the A/T slips.	ON vehicle	1. A/T fluid leakage	—
				2. Output speed sensor and vehicle speed signal	TM-52 , TM-74
				3. Direct clutch solenoid valve	TM-79
				4. CAN communication line	TM-45
				5. Line pressure test	TM-149
				6. Control valve with TCM	TM-165
			OFF vehicle	7. Torque converter	TM-252
				8. Oil pump assembly	TM-253
				9. 3rd one-way clutch	TM-256
				10. 1st one-way clutch	TM-263
				11. Gear system	TM-201
				12. Reverse brake	TM-211
				13. Forward one-way clutch (Parts behind drum support is impossible to perform inspection by disassembly. Refer to TM-19 , " Cross-Sectional View ".)	TM-211
				14. Forward brake (Parts behind drum support is impossible to perform inspection by disassembly. Refer to TM-19 , " Cross-Sectional View ".)	TM-211
35	Slips/Will Not Engage	With selector lever in "D" position, acceleration is extremely poor.	ON vehicle	1. A/T fluid leakage	—
				2. Line pressure test	TM-149
				3. Accelerator pedal position sensor	TM-70
				4. CAN communication line	TM-45
				5. Transmission range switch	TM-49
				6. A/T position	TM-155 (2WD), TM-155 (AWD)
				7. Control valve with TCM	TM-165
			OFF vehicle	8. Torque converter	TM-252
				9. Oil pump assembly	TM-253
				10. 1st one-way clutch	TM-263
				11. Gear system	TM-201
				12. Reverse brake	TM-211
				13. Forward one-way clutch (Parts behind drum support is impossible to perform inspection by disassembly. Refer to TM-19 , " Cross-Sectional View ".)	TM-211
				14. Forward brake (Parts behind drum support is impossible to perform inspection by disassembly. Refer to TM-19 , " Cross-Sectional View ".)	TM-211

SYSTEM SYMPTOM

< SYMPTOM DIAGNOSIS >

[5AT: RE5R05A]

No.	Item	Symptom	Condition	Diagnostic item	Reference
36		With selector lever in "R" position, acceleration is extremely poor.	ON vehicle	1. A/T fluid leakage	—
				2. Line pressure test	TM-149
				3. Accelerator pedal position sensor	TM-70
				4. High and low reverse clutch solenoid valve	TM-80
				5. CAN communication line	TM-45
				6. Transmission range switch	TM-49
				7. A/T position	TM-155 (2WD), TM-155 (AWD)
				8. Control valve with TCM	TM-165
			OFF vehicle	9. Gear system	TM-201
				10. Output shaft	TM-211
				11. Reverse brake	TM-211
37	Slips/Will Not Engage	While starting off by accelerating in 1st, engine races or slippage occurs.	ON vehicle	1. A/T fluid leakage	—
				2. Line pressure test	TM-149
				3. Accelerator pedal position sensor	TM-70
				4. CAN communication line	TM-45
				5. Control valve with TCM	TM-165
			OFF vehicle	6. Torque converter	TM-252
				7. Oil pump assembly	TM-253
				8. 3rd one-way clutch	TM-256
				9. 1st one-way clutch	TM-263
				10. Gear system	TM-201
				11. Reverse brake	TM-211
				12. Forward one-way clutch (Parts behind drum support is impossible to perform inspection by disassembly. Refer to TM-19 , "Cross-Sectional View".)	TM-211
				13. Forward brake (Parts behind drum support is impossible to perform inspection by disassembly. Refer to TM-19 , "Cross-Sectional View".)	TM-211

A
B
C
TM
E
F
G
H
I
J
K
L
M
N
O
P

SYSTEM SYMPTOM

< SYMPTOM DIAGNOSIS >

[5AT: RE5R05A]

No.	Item	Symptom	Condition	Diagnostic item	Reference
38		While accelerating in 2nd, engine races or slippage occurs.	ON vehicle	1. A/T fluid leakage	—
				2. Line pressure test	TM-149
				3. Accelerator pedal position sensor	TM-70
				4. CAN communication line	TM-45
				5. Direct clutch solenoid valve	TM-79
				6. Control valve with TCM	TM-165
			OFF vehicle	7. Torque converter	TM-252
				8. Oil pump assembly	TM-253
				9. 3rd one-way clutch	TM-256
				10. Gear system	TM-201
				11. Direct clutch	TM-270
			12. Forward brake (Parts behind drum support is impossible to perform inspection by disassembly. Refer to TM-19 , " Cross-Sectional View ".)	TM-211	
39	Slips/Will Not Engage	While accelerating in 3rd, engine races or slippage occurs.	ON vehicle	1. A/T fluid leakage	—
				2. Line pressure test	TM-149
				3. Accelerator pedal position sensor	TM-70
				4. CAN communication line	TM-45
				5. High and low reverse clutch solenoid valve	TM-80
				6. Control valve with TCM	TM-165
			OFF vehicle	7. Torque converter	TM-252
				8. Oil pump assembly	TM-253
				9. 3rd one-way clutch	TM-256
				10. Gear system	TM-201
				11. High and low reverse clutch	TM-268
				12. Forward one-way clutch (Parts behind drum support is impossible to perform inspection by disassembly. Refer to TM-19 , " Cross-Sectional View ".)	TM-211
				13. Forward brake (Parts behind drum support is impossible to perform inspection by disassembly. Refer to TM-19 , " Cross-Sectional View ".)	TM-211
40		While accelerating in 4th, engine races or slippage occurs.	ON vehicle	1. A/T fluid leakage	—
				2. Line pressure test	TM-149
				3. Accelerator pedal position sensor	TM-70
				4. CAN communication line	TM-45
				5. Input clutch solenoid valve	TM-77
				6. Control valve with TCM	TM-165
			OFF vehicle	7. Torque converter	TM-252
				8. Oil pump assembly	TM-253
				9. Input clutch	TM-258
				10. Gear system	TM-201
				11. High and low reverse clutch	TM-268
				12. Direct clutch	TM-270

SYSTEM SYMPTOM

< SYMPTOM DIAGNOSIS >

[5AT: RE5R05A]

No.	Item	Symptom	Condition	Diagnostic item	Reference
41	Slips/Will Not Engage	While accelerating in 5th, engine races or slippage occurs.	ON vehicle	1. A/T fluid leakage	—
				2. Line pressure test	TM-149
				3. Accelerator pedal position sensor	TM-70
				4. CAN communication line	TM-45
				5. Front brake solenoid valve	TM-78
				6. Control valve with TCM	TM-165
			OFF vehicle	7. Torque converter	TM-252
				8. Oil pump assembly	TM-253
				9. Front brake (brake band)	TM-201
				10. Input clutch	TM-258
				11. Gear system	TM-201
				12. High and low reverse clutch	TM-268
42	Slips at lock-up.	Slips at lock-up.	ON vehicle	1. A/T fluid leakage	—
				2. Line pressure test	TM-149
				3. Engine speed signal	TM-55
				4. Input speed sensor	TM-51
				5. Torque converter clutch solenoid valve	TM-67
				6. CAN communication line	TM-45
				7. Control valve with TCM	TM-165
			OFF vehicle	8. Torque converter	TM-252
				9. Oil pump assembly	TM-253

A
B
C
TM
E
F
G
H
I
J
K
L
M
N
O
P

SYSTEM SYMPTOM

< SYMPTOM DIAGNOSIS >

[5AT: RE5R05A]

No.	Item	Symptom	Condition	Diagnostic item	Reference
43	Slips/Will Not Engage	No creep at all.	ON vehicle	1. A/T fluid leakage	—
				2. Line pressure test	TM-149
				3. Accelerator pedal position sensor	TM-70
				4. Direct clutch solenoid valve	TM-79
				5. Transmission range switch	TM-49
				6. CAN communication line	TM-45
				7. A/T position	TM-155 (2WD), TM-155 (AWD)
				8. Control valve with TCM	TM-165
			OFF vehicle	9. Torque converter	TM-252
				10. Oil pump assembly	TM-253
				11. 1st one-way clutch	TM-263
				12. Gear system	TM-201
				13. Reverse brake	TM-211
				14. Direct clutch	TM-270
				15. Forward one-way clutch (Parts behind drum support is impossible to perform inspection by disassembly. Refer to TM-19 , " Cross-Sectional View ".)	TM-211
				16. Forward brake (Parts behind drum support is impossible to perform inspection by disassembly. Refer to TM-19 , " Cross-Sectional View ".)	TM-211
44	Vehicle cannot run in all positions.	Vehicle cannot run in all positions.	ON vehicle	1. A/T fluid leakage	—
				2. Line pressure test	TM-149
				3. Transmission range switch	TM-49
				4. A/T position	TM-155 (2WD), TM-155 (AWD)
				5. Control valve with TCM	TM-165
			OFF vehicle	6. Oil pump assembly	TM-253
				7. Gear system	TM-201
				8. Output shaft	TM-211

SYSTEM SYMPTOM

< SYMPTOM DIAGNOSIS >

[5AT: RE5R05A]

No.	Item	Symptom	Condition	Diagnostic item	Reference
45	Slips/Will Not Engage	With selector lever in "D" position, driving is not possible.	ON vehicle	1. A/T fluid leakage	—
				2. Line pressure test	TM-149
				3. Transmission range switch	TM-49
				4. A/T position	TM-155 (2WD), TM-155 (AWD)
				5. Control valve with TCM	TM-165
			OFF vehicle	6. Torque converter	TM-252
				7. Oil pump assembly	TM-253
				8. 1st one-way clutch	TM-263
				9. Gear system	TM-201
				10. Reverse brake	TM-211
				11. Forward one-way clutch (Parts behind drum support is impossible to perform inspection by disassembly. Refer to TM-19 . "Cross-Sectional View".)	TM-211
				12. Forward brake (Parts behind drum support is impossible to perform inspection by disassembly. Refer to TM-19 . "Cross-Sectional View".)	TM-211
46		With selector lever in "R" position, driving is not possible.	ON vehicle	1. A/T fluid leakage	—
				2. Line pressure test	TM-149
				3. Transmission range switch	TM-49
				4. A/T position	TM-155 (2WD), TM-155 (AWD)
				5. Control valve with TCM	TM-165
			OFF vehicle	6. Gear system	TM-201
				7. Output shaft	TM-211
				8. Reverse brake	TM-211
47	Does Not Change	Does not change M5 → M4.	ON vehicle	1. Transmission range switch	TM-49
				2. A/T fluid leakage	—
				3. A/T position	TM-155 (2WD), TM-155 (AWD)
				4. Manual mode switch	TM-84
				5. CAN communication line	TM-45
				6. Control valve with TCM	TM-165
			OFF vehicle	7. Front brake (brake band)	TM-201

A
B
C
TM
E
F
G
H
I
J
K
L
M
N
O
P

SYSTEM SYMPTOM

< SYMPTOM DIAGNOSIS >

[5AT: RE5R05A]

No.	Item	Symptom	Condition	Diagnostic item	Reference
48	Does Not Change	Does not change M4 → M3.	ON vehicle	1. Transmission range switch	TM-49
				2. A/T fluid leakage	—
				3. A/T position	TM-155 (2WD), TM-155 (AWD)
				4. Manual mode switch	TM-84
				5. CAN communication line	TM-45
				6. Control valve with TCM	TM-165
			OFF vehicle	7. Front brake (brake band)	TM-201
				8. Input clutch	TM-258
49	Does Not Change	Does not change M3 → M2.	ON vehicle	1. Transmission range switch	TM-49
				2. A/T fluid leakage	—
				3. A/T position	TM-155 (2WD), TM-155 (AWD)
				4. Manual mode switch	TM-84
				5. CAN communication line	TM-45
				6. Control valve with TCM	TM-165
			OFF vehicle	7. Front brake (brake band)	TM-201
				8. Input clutch	TM-258
				9. High and low reverse clutch	TM-268
50	Does Not Change	Does not change M2 → M1.	ON vehicle	1. Transmission range switch	TM-49
				2. A/T fluid leakage	—
				3. A/T position	TM-155 (2WD), TM-155 (AWD)
				4. Manual mode switch	TM-84
				5. CAN communication line	TM-45
				6. Control valve with TCM	TM-165
			OFF vehicle	7. Input clutch	TM-258
				8. High and low reverse clutch	TM-268
				9. Direct clutch	TM-270
51	Does Not Change	Cannot be changed to manual mode.	ON vehicle	1. Manual mode switch	TM-84
				2. Input speed sensor	TM-51
				3. CAN communication line	TM-45

SYSTEM SYMPTOM

< SYMPTOM DIAGNOSIS >

[5AT: RE5R05A]

No.	Item	Symptom	Condition	Diagnostic item	Reference
52		Shift point is high in "D" position.	ON vehicle	1. Output speed sensor and vehicle speed signal	TM-52 , TM-74
				2. Accelerator pedal position sensor	TM-70
				3. CAN communication line	TM-45
				4. A/T fluid temperature sensor	TM-71
				5. Control valve with TCM	TM-165
53		Shift point is low in "D" position.	ON vehicle	1. Output speed sensor and vehicle speed signal	TM-52 , TM-74
				2. Accelerator pedal position sensor	TM-70
				3. CAN communication line	TM-45
				4. Control valve with TCM	TM-165
54	Others	Judder occurs during lock-up.	ON vehicle	1. A/T fluid leakage	—
				2. Engine speed signal	TM-55
				3. Input speed sensor	TM-51
				4. Output speed sensor and vehicle speed signal	TM-52 , TM-74
				5. Accelerator pedal position sensor	TM-70
				6. CAN communication line	TM-45
				7. Torque converter clutch solenoid valve	TM-67
				8. Control valve with TCM	TM-165
			OFF vehicle	9. Torque converter	TM-252
55		Strange noise in "R" position.	ON vehicle	1. A/T fluid leakage	—
				2. Engine speed signal	TM-55
				3. CAN communication line	TM-45
				4. Control valve with TCM	TM-165
			OFF vehicle	5. Torque converter	TM-252
				6. Oil pump assembly	TM-253
				7. Gear system	TM-201
				8. High and low reverse clutch	TM-268
				9. Reverse brake	TM-211
56		Strange noise in "N" position.	ON vehicle	1. A/T fluid leakage	—
				2. Engine speed signal	TM-55
				3. CAN communication line	TM-45
				4. Control valve with TCM	TM-165
			OFF vehicle	5. Torque converter	TM-252
				6. Oil pump assembly	TM-253
				7. Gear system	TM-201

A
B
C
TM
E
F
G
H
I
J
K
L
M
N
O
P

SYSTEM SYMPTOM

< SYMPTOM DIAGNOSIS >

[5AT: RE5R05A]

No.	Item	Symptom	Condition	Diagnostic item	Reference				
57		Strange noise in "D" position.	ON vehicle	1. A/T fluid leakage	—				
				2. Engine speed signal	TM-55				
				3. CAN communication line	TM-45				
				4. Control valve with TCM	TM-165				
			OFF vehicle	5. Torque converter	TM-252				
				6. Oil pump assembly	TM-253				
				7. Gear system	TM-201				
				8. Forward brake (Parts behind drum support is impossible to perform inspection by disassembly. Refer to TM-19 , "Cross-Sectional View".)	TM-211				
58	Others	Vehicle does not decelerate by engine brake.	ON vehicle	1. Transmission range switch	TM-49				
				2. A/T fluid leakage	—				
				3. A/T position	TM-155 (2WD), TM-155 (AWD)				
				4. Manual mode switch	TM-84				
				5. CAN communication line	TM-45				
				6. Control valve with TCM	TM-165				
			OFF vehicle	7. Input clutch	TM-258				
				8. High and low reverse clutch	TM-268				
				9. Direct clutch	TM-270				
				59		Engine brake does not work M5 → M4.	ON vehicle	1. Transmission range switch	TM-49
								2. A/T fluid leakage	—
								3. A/T position	TM-155 (2WD), TM-155 (AWD)
4. Manual mode switch	TM-84								
5. CAN communication line	TM-45								
6. Control valve with TCM	TM-165								
OFF vehicle	7. Front brake (brake band)	TM-201							
60		Engine brake does not work M4 → M3.	ON vehicle	1. Transmission range switch	TM-49				
				2. A/T fluid leakage	—				
				3. A/T position	TM-155 (2WD), TM-155 (AWD)				
				4. Manual mode switch	TM-84				
				5. CAN communication line	TM-45				
				6. Control valve with TCM	TM-165				
			OFF vehicle	7. Front brake (brake band)	TM-201				
			8. Input clutch	TM-258					

SYSTEM SYMPTOM

< SYMPTOM DIAGNOSIS >

[5AT: RE5R05A]

No.	Item	Symptom	Condition	Diagnostic item	Reference
61	Others	Engine brake does not work M3 → M2.	ON vehicle	1. Transmission range switch	TM-49
				2. A/T fluid leakage	—
				3. A/T position	TM-155 (2WD), TM-155 (AWD)
				4. Manual mode switch	TM-84
				5. CAN communication line	TM-45
				6. Control valve with TCM	TM-165
			OFF vehicle	7. Front brake (brake band)	TM-201
				8. Input clutch	TM-258
				9. High and low reverse clutch	TM-268
62	Others	Engine brake does not work M2 → M1.	ON vehicle	1. Transmission range switch	TM-49
				2. A/T fluid leakage	—
				3. A/T position	TM-155 (2WD), TM-155 (AWD)
				4. Manual mode switch	TM-84
				5. CAN communication line	TM-45
				6. Control valve with TCM	TM-165
			OFF vehicle	7. Input clutch	TM-258
				8. High and low reverse clutch	TM-268
				9. Direct clutch	TM-270
63	Others	Maximum speed low.	ON vehicle	1. A/T fluid leakage	—
				2. Line pressure test	TM-149
				3. Accelerator pedal position sensor	TM-70
				4. CAN communication line	TM-45
				5. Direct clutch solenoid valve	TM-79
				6. Control valve with TCM	TM-165
			OFF vehicle	7. Torque converter	TM-252
				8. Oil pump assembly	TM-253
				9. Input clutch	TM-258
				10. Gear system	TM-201
				11. High and low reverse clutch	TM-268
				12. Direct clutch	TM-270
				13. Forward one-way clutch (Parts behind drum support is impossible to perform inspection by disassembly. Refer to TM-19 , " Cross-Sectional View ".)	TM-211
				14. Forward brake (Parts behind drum support is impossible to perform inspection by disassembly. Refer to TM-19 , " Cross-Sectional View ".)	TM-211

A
B
C
TM
E
F
G
H
I
J
K
L
M
N
O
P

SYSTEM SYMPTOM

< SYMPTOM DIAGNOSIS >

[5AT: RE5R05A]

No.	Item	Symptom	Condition	Diagnostic item	Reference
64		Extremely large creep.	ON vehicle	1. Engine idle speed	EC-17
			OFF vehicle	2. CAN communication line	TM-45
65		With selector lever in "P" position, vehicle does not enter parking condition or, with selector lever in another position, parking condition is not cancelled.	ON vehicle	3. Torque converter	TM-252
			ON vehicle	1. Transmission range switch	TM-49
				2. A/T position	TM-155 (2WD), TM-155 (AWD)
OFF vehicle	3. Parking components	TM-174 (2WD), TM-201 (AWD)			
66	Others	Vehicle runs with A/T in "P" position.	ON vehicle	1. Transmission range switch	TM-49
				2. A/T fluid leakage	—
				3. A/T position	TM-155 (2WD), TM-155 (AWD)
				4. Control valve with TCM	TM-165
			OFF vehicle	5. Parking components	TM-174 (2WD), TM-201 (AWD)
				6. Gear system	TM-201
67	Others	Vehicle runs with A/T in "N" position.	ON vehicle	1. Transmission range switch	TM-49
				2. A/T fluid leakage	—
				3. A/T position	TM-155 (2WD), TM-155 (AWD)
				4. Control valve with TCM	TM-165
			OFF vehicle	5. Input clutch	TM-258
				6. Gear system	TM-201
				7. Direct clutch	TM-270
				8. Reverse brake	TM-211
				9. Forward one-way clutch (Parts behind drum support is impossible to perform inspection by disassembly. Refer to TM-19 , " Cross-Sectional View ".)	TM-211
				10. Forward brake (Parts behind drum support is impossible to perform inspection by disassembly. Refer to TM-19 , " Cross-Sectional View ".)	TM-211
68		Engine does not start in "N" or "P" position.	ON vehicle	1. Push-button ignition switch and starter	PG-53 , STR-9
				2. A/T position	TM-155 (2WD), TM-155 (AWD)
				3. Transmission range switch	TM-49

SYSTEM SYMPTOM

< SYMPTOM DIAGNOSIS >

[5AT: RE5R05A]

No.	Item	Symptom	Condition	Diagnostic item	Reference
69		Engine starts in positions other than "N" or "P".	ON vehicle	1. Push-button ignition switch and starter	PG-53 , STR-9
				2. A/T position	TM-155 (2WD), TM-155 (AWD)
				3. Transmission range switch	TM-49
70		Engine stall.	ON vehicle	1. A/T fluid leakage	—
				2. Engine speed signal	TM-55
				3. Input speed sensor	TM-51
				4. Torque converter clutch solenoid valve	TM-67
				5. CAN communication line	TM-45
			6. Control valve with TCM	TM-165	
			OFF vehicle	7. Torque converter	TM-252
71	Others	Engine stalls when selector lever shifted "N" → "D" or "R".	ON vehicle	1. A/T fluid leakage	—
				2. Engine speed signal	TM-55
				3. Input speed sensor	TM-51
				4. Torque converter clutch solenoid valve	TM-67
				5. CAN communication line	TM-45
			6. Control valve with TCM	TM-165	
72		Engine speed does not return to idle.	ON vehicle	1. A/T fluid leakage	—
				2. Direct clutch solenoid valve	TM-79
				3. Front brake solenoid valve	TM-78
				4. Accelerator pedal position sensor	TM-70
				5. Output speed sensor and vehicle speed signal	TM-52 , TM-74
				6. CAN communication line	TM-45
			7. Control valve with TCM	TM-165	
			OFF vehicle	8. Front brake (brake band)	TM-201
				9. Direct clutch	TM-270
73		A/T CHECK indicator lamp does not come on.	ON vehicle	1. CAN communication line	TM-45
				2. Combination meters	MWI-6
				3. Unified meter and A/C amp.	
				4. TCM power supply and ground	TM-88
74		Unable to perform self-diagnosis.	ON vehicle	1. CAN communication line	TM-45
				2. Transmission range switch	TM-49
				3. Manual mode switch	TM-84
				4. Closed throttle and wide open throttle position signal	EC-447
				5. Stop lamp switch signal	SEC-52

A
B
C
TM
E
F
G
H
I
J
K
L
M
N
O
P

SYSTEM SYMPTOM

< SYMPTOM DIAGNOSIS >

[5AT: RE5R05A]

No.	Item	Symptom	Condition	Diagnostic item	Reference
75		When brake pedal is depressed with ignition switch ON, selector lever cannot be shifted from "P" position to other position.	ON vehicle	1. Stop lamp switch	TM-91
				2. Shift lock relay	
				3. Shift lock solenoid	
76	Others	When brake pedal is not depressed with ignition switch ON, selector lever can be shifted from "P" position to other position.	ON vehicle	1. Stop lamp switch	TM-91
				2. ICC brake hold relay (with ICC)	
				3. ICC sensor integrated unit (with ICC)	
				4. Shift lock relay	
				5. Shift lock solenoid	

PRECAUTION

PRECAUTIONS

Precaution for Supplemental Restraint System (SRS) "AIR BAG" and "SEAT BELT PRE-TENSIONER"

INFOID:000000004924726

The Supplemental Restraint System such as "AIR BAG" and "SEAT BELT PRE-TENSIONER", used along with a front seat belt, helps to reduce the risk or severity of injury to the driver and front passenger for certain types of collision. This system includes seat belt switch inputs and dual stage front air bag modules. The SRS system uses the seat belt switches to determine the front air bag deployment, and may only deploy one front air bag, depending on the severity of a collision and whether the front occupants are belted or unbelted. Information necessary to service the system safely is included in the "SRS AIR BAG" and "SEAT BELT" of this Service Manual.

WARNING:

- To avoid rendering the SRS inoperative, which could increase the risk of personal injury or death in the event of a collision that would result in air bag inflation, all maintenance must be performed by an authorized NISSAN/INFINITI dealer.
- Improper maintenance, including incorrect removal and installation of the SRS, can lead to personal injury caused by unintentional activation of the system. For removal of Spiral Cable and Air Bag Module, see the "SRS AIR BAG".
- Do not use electrical test equipment on any circuit related to the SRS unless instructed to in this Service Manual. SRS wiring harnesses can be identified by yellow and/or orange harnesses or harness connectors.

PRECAUTIONS WHEN USING POWER TOOLS (AIR OR ELECTRIC) AND HAMMERS

WARNING:

- When working near the Air Bag Diagnosis Sensor Unit or other Air Bag System sensors with the ignition ON or engine running, DO NOT use air or electric power tools or strike near the sensor(s) with a hammer. Heavy vibration could activate the sensor(s) and deploy the air bag(s), possibly causing serious injury.
- When using air or electric power tools or hammers, always switch the ignition OFF, disconnect the battery, and wait at least 3 minutes before performing any service.

On Board Diagnosis (OBD) System of A/T and Engine

INFOID:000000004342988

The ECM has an on board diagnostic system. It will light up the malfunction indicator lamp (MIL) to warn the driver of a malfunction causing emission deterioration.

CAUTION:

- Be sure to turn the ignition switch OFF and disconnect the battery cable from the negative terminal before any repair or inspection work. The open/short circuit of related switches, sensors, solenoid valves, etc. will cause the MIL to light up.
- Be sure to connect and lock the connectors securely after work. A loose (unlocked) connector will cause the MIL to light up due to an open circuit. (Be sure the connector is free from water, grease, dirt, bent terminals, etc.)
- Be sure to route and secure the harnesses properly after work. Interference of the harness with a bracket, etc. may cause the MIL to light up due to a short circuit.
- Be sure to connect rubber tubes properly after work. A misconnected or disconnected rubber tube may cause the MIL to light up due to a malfunction of the EVAP system or fuel injection system, etc.
- Be sure to erase the unnecessary malfunction information (repairs completed) from the TCM and ECM before returning the vehicle to the customer.

A
B
C
TM
E
F
G
H
I
J
K
L
M
N
O
P

PRECAUTIONS

< PRECAUTION >

[5AT: RE5R05A]

General Precautions

INFOID:000000004342989

- Turn ignition switch OFF and disconnect the battery cable from the negative terminal before connecting or disconnecting the A/T assembly harness connector. Because battery voltage is applied to TCM even if ignition switch is turned OFF.

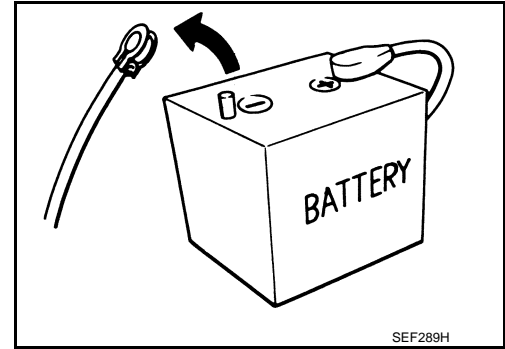

- Perform "DTC (Diagnostic Trouble Code) CONFIRMATION PROCEDURE" after performing each TROUBLE DIAGNOSIS. If the repair is completed DTC should not be displayed in the "DTC CONFIRMATION PROCEDURE".
- Always use the specified brand of ATF. Refer to [MA-10, "Fluids and Lubricants"](#).
- Use lint-free paper not cloth rags during work.
- Dispose of the waste oil using the methods prescribed by law, ordinance, etc. after replacing the ATF.
- Before proceeding with disassembly, thoroughly clean the outside of the transmission. It is important to prevent the internal parts from becoming contaminated by dirt or other foreign matter.
- Disassembly should be done in a clean work area.
- Use lint-free paper or towels for wiping parts clean. Common shop rags can leave fibers that could interfere with the operation of the transmission.
- Place disassembled parts in order for easier and proper assembly.
- All parts should be carefully cleaned with a general purpose, non-flammable solvent before inspection or reassembly.
- Gaskets, seals and O-rings should be replaced any time the A/T is disassembled.
- It is very important to perform functional tests whenever they are indicated.
- The valve body contains precision parts and requires extreme care when parts are removed and serviced. Place disassembled valve body parts in order for easier and proper assembly. Care will also prevent springs and small parts from becoming scattered or lost.
- Properly installed valves, sleeves, plugs, etc. will slide along bores in valve body under their own weight.
- Before assembly, apply a coat of recommended ATF to all parts. Apply petroleum jelly to protect O-rings and seals, or hold bearings and washers in place during assembly. Do not use grease.
- Extreme care should be taken to avoid damage to O-rings, seals and gaskets when assembling.
- Clean or replace ATF cooler if excessive foreign material is found in oil pan or clogging strainer. Refer to [TM-138, "Service Notice or Precaution"](#).
- Refill the transmission with new ATF after overhaul.
- When the A/T drain plug is removed, only some of the ATF is drained. Old ATF will remain in torque converter and ATF cooling system. Always follow the procedures under "Changing" and "Adjustment" when changing ATF. Refer to [TM-142, "Changing"](#), [TM-143, "Adjustment"](#).

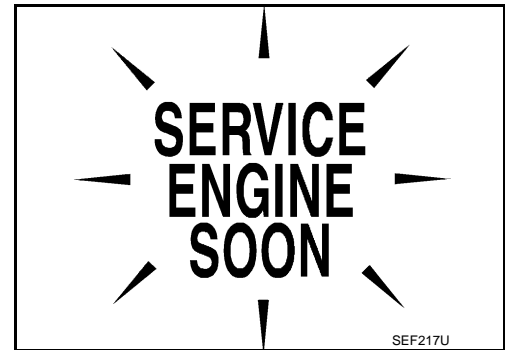

Service Notice or Precaution

INFOID:000000004342990

ATF COOLER SERVICE

If ATF contains frictional material (clutches, bands, etc.), or if an A/T is repaired, overhauled, or replaced, inspect and clean the A/T fluid cooler mounted in the radiator or replace the radiator. Flush cooler lines using cleaning solvent and compressed air after repair. For A/T fluid cooler cleaning procedure, refer to [TM-145, "Cleaning"](#). For radiator replacement, refer to [CO-12, "Exploded View"](#).

OBD-II SELF-DIAGNOSIS

- A/T self-diagnosis is performed by the TCM in combination with the ECM. The results can be read through the blinking pattern of the A/T CHECK indicator lamp or the malfunction indicator lamp (MIL). Refer to the

PRECAUTIONS

< PRECAUTION >

[5AT: RE5R05A]

table on "SELF-DIAGNOSTIC RESULTS" for the indicator used to display each self-diagnostic result. Refer to [TM-40, "CONSULT-III Function \(TRANSMISSION\)"](#).

- The self-diagnostic results indicated by the MIL are automatically stored in both the ECM and TCM memories.

Always perform the procedure on "How to Erase DTC" to complete the repair and avoid unnecessary blinking of the MIL. Refer to [TM-39, "Diagnosis Description"](#).

For details of OBD-II, refer to [EC-104, "Diagnosis Description"](#).

- **Certain systems and components, especially those related to OBD, may use the new style slide-locking type harness connector. For description and how to disconnect, refer to [PG-94, "Description"](#).**

A

B

C

TM

E

F

G

H

I

J

K

L

M

N

O

P

PREPARATION

< PREPARATION >

[5AT: RE5R05A]

PREPARATION

PREPARATION

Special Service Tool

INFOID:000000004342991

The actual shapes of Kent-Moore tools may differ from those of special service tools illustrated here.

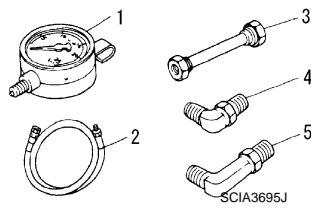
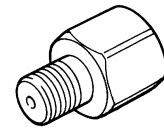
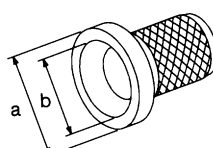
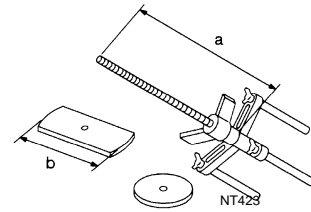
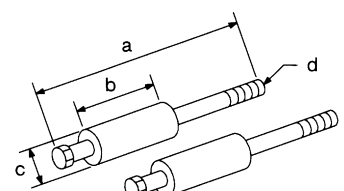
Tool number (Kent-Moore No.) Tool name	Description	
ST2505S001 (J-34301-C) Oil pressure gauge set 1. ST25051001 (—) Oil pressure gauge 2. ST25052000 (—) Hose 3. ST25053000 (—) Joint pipe 4. ST25054000 (—) Adapter 5. ST25055000 (—) Adapter	 <p style="text-align: center;">SCIA3695J</p>	Measuring line pressure
KV31103600 (J-45674) Joint pipe adapter (With ST25054000)	 <p style="text-align: center;">ZZA1227D</p>	Measuring line pressure
ST33400001 (J-26082) Drift a: 60 mm (2.36 in) dia. b: 47 mm (1.85 in) dia.	 <p style="text-align: center;">NT086</p>	<ul style="list-style-type: none"> • Installing rear oil seal (2WD) • Installing oil pump housing oil seal
KV31102400 (J-34285 and J-34285-87) Clutch spring compressor a: 320 mm (12.60 in) b: 174 mm (6.85 in)	 <p style="text-align: center;">NT428</p>	Installing reverse brake return spring retainer
ST25850000 (J-25721-A) Sliding hammer a: 179 mm (7.05 in) b: 70 mm (2.76 in) c: 40 mm (1.57 in) d: M12X1.75P	 <p style="text-align: center;">NT422</p>	Remove oil pump assembly

PREPARATION

< PREPARATION >

[5AT: RE5R05A]

Commercial Service Tool

INFOID:000000004342992

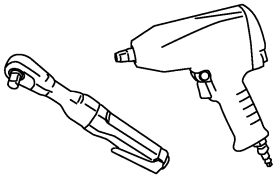
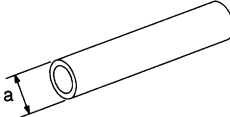
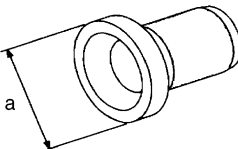
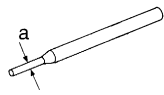
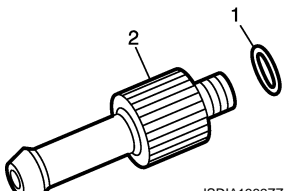
Tool number Tool name	Description
Power tool  <p style="text-align: right;">PBIC0190E</p>	Loosening bolts and nuts
Drift a: 22 mm (0.87 in) dia.  <p style="text-align: right;">NT083</p>	Installing manual shaft oil seals
Drift a: 64 mm (2.52 in) dia.  <p style="text-align: right;">SCIA5338E</p>	Installing rear oil seal (AWD)
Pin punch a: 4 mm (0.16 in) dia.  <p style="text-align: right;">NT410</p>	Remove retaining pin
<ol style="list-style-type: none"> 1. 315268E000* O-ring 2. 310811EA5A* Charging pipe  <p style="text-align: right;">JSDIA1332ZZ</p>	A/T fluid changing and adjustment

*: Always check with the Parts Department for the latest parts information.

A
B
C
TM
E
F
G
H
I
J
K
L
M
N
O
P

PERIODIC MAINTENANCE

A/T FLUID

Changing

INFOID:000000004495398

Recommended fluid and fluid capacity : Refer to [TM-272, "General Specification"](#).

CAUTION:

- If Genuine NISSAN Matic S ATF is not available, Genuine NISSAN Matic J ATF may also be used.
- Using ATF other than Genuine NISSAN Matic S ATF will cause deterioration in driveability and A/T durability, and may damage the A/T, which is not covered by the INFINITI new vehicle limited warranty.
- When filling ATF, be careful not to scatter heat generating parts such as exhaust.

1. Step 1

- Install the O-ring (315268E000) (A) to the charging pipe (310811EA5A) (B).

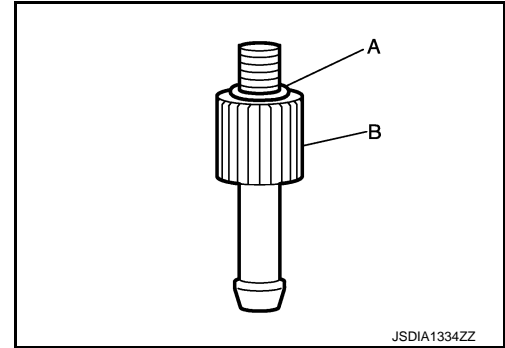

2. Step 2

- Use CONSULT-III to check that the ATF temperature is 40°C (104°F) or less.
- Lift up the vehicle.
- Remove the drain plug from the oil pan, and then drain the ATF.
- When the ATF starts to drip, temporarily tighten the drain plug to the oil pan.

NOTE:

Never replace drain plug and drain plug gasket with new ones yet.

- Remove overflow plug from oil pan.
- Install the charging pipe (A) to the overflow plug hole.

CAUTION:

Tighten the charging pipe by hand.

- Install the bucket pump hose (B) to the charging pipe.

CAUTION:

Insert the bucket pump hose all the way to the end of the charging pipe.

- Fill approximately 3 liters (3-1/8 US qt, 2-5/8 Imp qt) of the ATF.
- Remove the bucket pump hose to remove the charging pipe, and then temporarily tighten the overflow plug to the oil pan.

CAUTION:

Quickly perform the procedure to avoid ATF leakage from the oil pan.

- Lift down the vehicle.
- Start the engine and wait for approximately 3 minutes.
- Stop the engine.

3. Step 3

- Repeat "Step 2".

4. Final Step

- Use CONSULT-III to check that the ATF temperature is 40°C (104°F) or less.

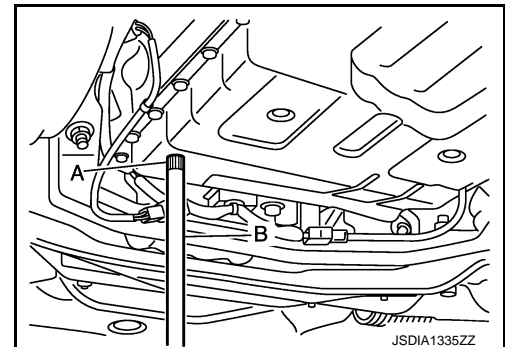

- b. Lift up the vehicle.
- c. Remove the drain plug from the oil pan, and then drain the ATF.
- d. When the ATF starts to drop, tighten the drain plug to the oil pan to the specified torque. Refer to [TM-165, "Exploded View"](#).
CAUTION:
Never reuse drain plug and drain plug gasket.
- e. Remove overflow plug from oil pan.
- f. Install the charging pipe (A) to the overflow plug hole.
CAUTION:
Tighten the charging pipe by hand.
- g. Install the bucket pump hose (B) to the charging pipe.
CAUTION:
Insert the bucket pump hose all the way to the end of the charging pipe.
- h. Fill approximately 3 liters (3-1/8 US qt, 2-5/8 Imp qt) of the ATF.
- i. Remove the bucket pump hose to remove the charging pipe, and then temporarily tighten the overflow plug to the oil pan.
CAUTION:
Quickly perform the procedure to avoid ATF leakage from the oil pan.
- j. Lift down the vehicle.
- k. Start the engine.
- l. Make the ATF temperature approximately 40°C (104°F).
NOTE:
The ATF level is greatly affected by the temperature. Always check the ATF temperature on "ATF TEMP 1" of "Data Monitor" using CONSULT-III.
- m. Park vehicle on level surface and set parking brake.
- n. Shift the selector lever through each gear position. Leave selector lever in "P" position.
- o. Lift up the vehicle when the ATF temperature reaches 40°C (104°F), and then remove the overflow plug from the oil pan.
- p. When the ATF starts to drop, tighten the overflow plug to the oil pan to the specified torque. Refer to [TM-165, "Exploded View"](#).
CAUTION:
Never reuse overflow plug.

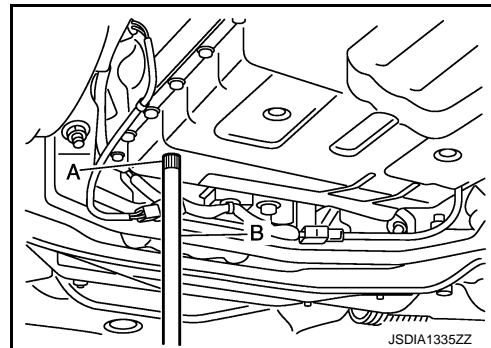

Adjustment

INFOID:000000004495399

Recommended fluid and fluid capacity : Refer to [TM-272, "General Specification"](#).

CAUTION:

- If Genuine NISSAN Matic S ATF is not available, Genuine NISSAN Matic J ATF may also be used.
- Using ATF other than Genuine NISSAN Matic S ATF will cause deterioration in driveability and A/T durability, and may damage the A/T, which is not covered by the INFINITI new vehicle limited warranty.
- When filling ATF, be careful not to scatter heat generating parts such as exhaust.
- Always maintain the ATF temperature within between 35°C (95°F) and 45°C (113°F) while checking with CONSULT-III when the ATF level adjustment is performed.

A/T FLUID

< PERIODIC MAINTENANCE >

[5AT: RE5R05A]

1. Install the O-ring (315268E000) (A) to the charging pipe (310811EA5A) (B).
2. Start the engine.
3. Make the ATF temperature approximately 40°C (104°F).

NOTE:

The ATF level is greatly affected by the temperature. Always check the ATF temperature on "ATF TEMP 1" of "Data Monitor" using CONSULT-III.

4. Park vehicle on level surface and set parking brake.
5. Shift the selector lever through each gear position. Leave selector lever in "P" position.
6. Lift up the vehicle.
7. Check the ATF leakage from transmission.
8. Remove overflow plug from oil pan.
9. Install the charging pipe (A) to the overflow plug hole.

CAUTION:

Tighten the charging pipe by hand.

10. Install the bucket pump hose (B) to the charging pipe.

CAUTION:

Insert the bucket pump hose all the way to the end of the charging pipe.

11. Fill approximately 0.5 liters (1/2 US qt, 1/2 Imp qt) of the ATF.
12. Check that the ATF leaks when removing the charging pipe and the bucket pump hose. If the ATF does not leak, refill the ATF.
13. When the ATF starts to drop, tighten the overflow plug to the oil pan to the specified torque. Refer to [TM-165, "Exploded View"](#).

CAUTION:

Never reuse overflow plug.

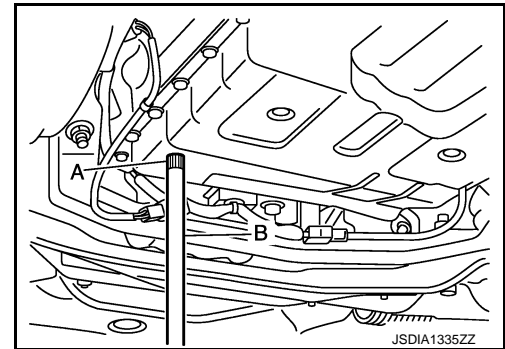
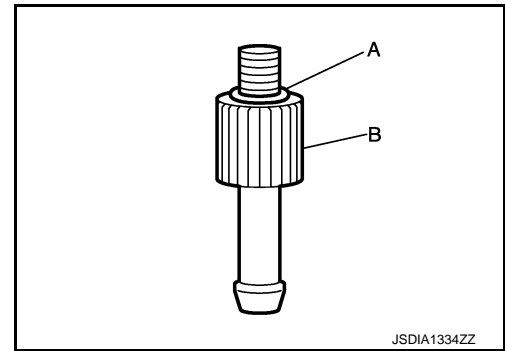

A/T FLUID COOLER

Cleaning

INFOID:000000004342995

Whenever an A/T is replaced, the A/T fluid cooler mounted in the radiator must be inspected and cleaned. Metal debris and friction material, if present, can become trapped in the A/T fluid cooler. This debris can contaminate the newly serviced A/T or, in severe cases, can block or restrict the flow of ATF. In either case, malfunction of the newly serviced A/T may result.

Debris, if present, may build up as ATF enters the cooler inlet. It will be necessary to back flush the cooler through the cooler outlet in order to flush out any built up debris.

CLEANING PROCEDURE

1. Position an oil pan under the A/T inlet and outlet cooler hoses.
2. Identify the inlet and outlet fluid cooler hoses.
3. Disconnect the A/T fluid cooler inlet and outlet rubber hoses from the steel cooler tubes or by-pass valve.

NOTE:

Replace the cooler hoses if rubber material from the hose remains on the tube fitting.

4. Allow any ATF that remains in the cooler hoses to drain into the oil pan.

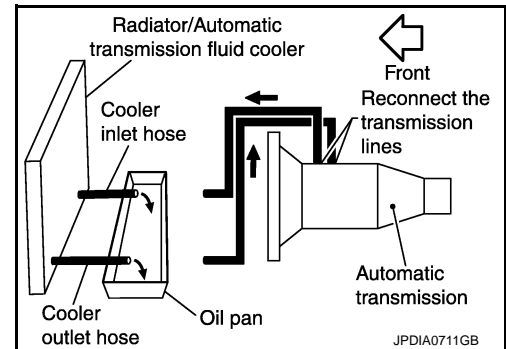

5. Insert the extension adapter hose of a can of Transmission Cooler Cleaner (Nissan P/N 999MP-AM006) into the cooler outlet hose.

CAUTION:

- Wear safety glasses and rubber gloves when spraying the Transmission Cooler Cleaner.
- Spray Transmission Cooler Cleaner only with adequate ventilation.
- Avoid contact with eyes and skin.
- Never breathe vapors or spray mist.

6. Hold the hose and can as high as possible and spray Transmission Cooler Cleaner in a continuous stream into the cooler outlet hose until ATF flows out of the cooler inlet hose for 5 seconds.

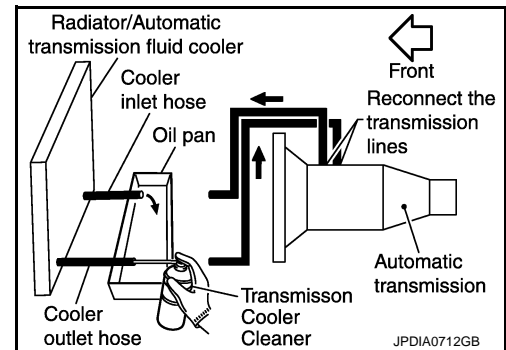

7. Insert the tip of an air gun into the end of the cooler outlet hose.
8. Wrap a shop rag around the air gun tip and of the cooler outlet hose.

9. Blow compressed air regulated to 5 to 9 kg/cm² (71 to 128 psi) through the cooler outlet hose for 10 seconds to force out any remaining ATF.

10. Repeat steps 5 through 9 three additional times.

11. Position an oil pan under the banjo bolts that connect the A/T fluid cooler steel lines to the A/T.

12. Remove the banjo bolts.

13. Flush each steel line from the cooler side back toward the A/T by spraying Transmission Cooler Cleaner in a continuous stream for 5 seconds.

14. Blow compressed air regulated to 5 to 9 kg/cm² (71 to 128 psi) through each steel line from the cooler side back toward the A/T for 10 seconds to force out any remaining ATF.

15. Ensure all debris is removed from the steel cooler lines.

16. Ensure all debris is removed from the banjo bolts and fittings.

17. Perform "DIAGNOSIS PROCEDURE".

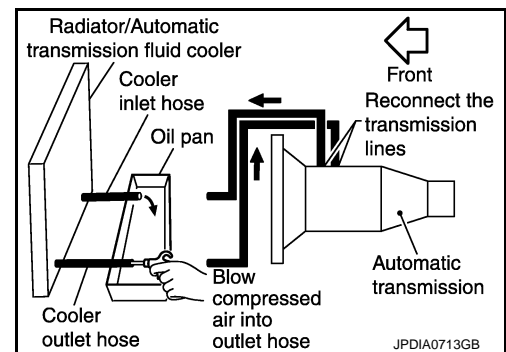

A/T FLUID COOLER

< PERIODIC MAINTENANCE >

[5AT: RE5R05A]

DIAGNOSIS PROCEDURE

NOTE:

Insufficient cleaning of the cooler inlet hose exterior may lead to inaccurate debris identification.

1. Position an oil pan under the A/T inlet and outlet cooler hoses.
2. Clean the exterior and tip of the cooler inlet hose.
3. Insert the extension adapter hose of a can of Transmission Cooler Cleaner (Nissan P/N 999MP-AM006) into the cooler outlet hose.

CAUTION:

- Wear safety glasses and rubber gloves when spraying the Transmission Cooler Cleaner.
- Spray Transmission Cooler Cleaner only with adequate ventilation.
- Avoid contact with eyes and skin.
- Never breathe vapors or spray mist.

4. Hold the hose and can as high as possible and spray Transmission Cooler Cleaner in a continuous stream into the cooler outlet hose until ATF flows out of the cooler inlet hose for 5 seconds.
5. Tie a common white, basket-type coffee filter to the end of the cooler inlet hose.

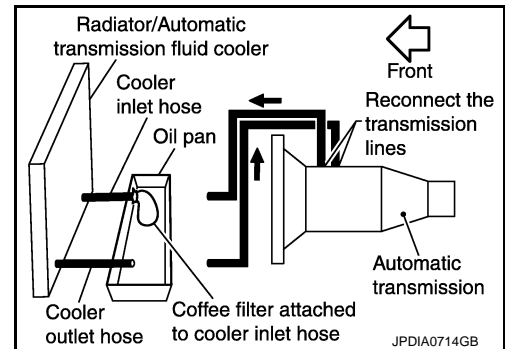
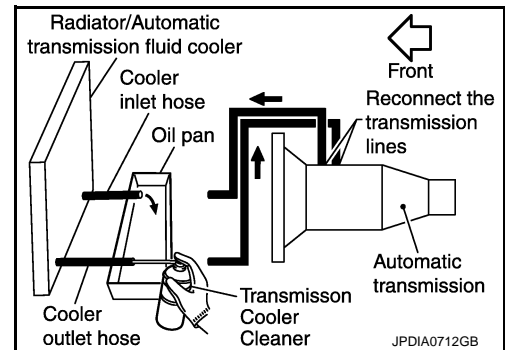

6. Insert the tip of an air gun into the end of the cooler outlet hose.
7. Wrap a shop rag around the air gun tip and end of cooler outlet hose.
8. Blow compressed air regulated to 5 to 9 kg/cm² (71 to 128 psi) through the cooler outlet hose to force any remaining ATF into the coffee filter.
9. Remove the coffee filter from the end of the cooler inlet hose.
10. Perform "INSPECTION PROCEDURE".

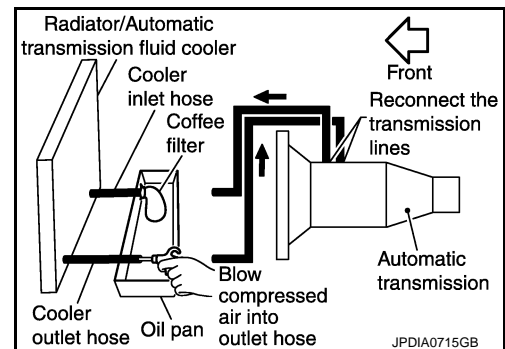

INSPECTION PROCEDURE

1. Inspect the coffee filter for debris.
 - a. If small metal debris less than 1 mm (0.040 in) in size or metal powder is found in the coffee filter, this is normal. If normal debris is found, the A/T fluid cooler/radiator can be re-used and the procedure is ended.

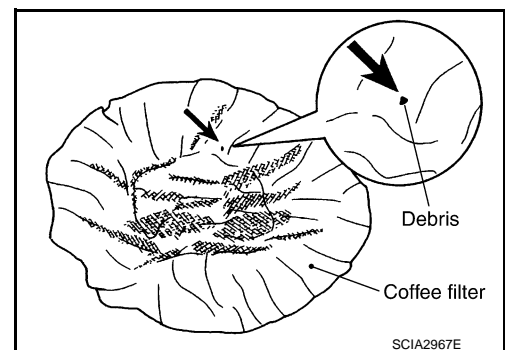

A/T FLUID COOLER

< PERIODIC MAINTENANCE >

[5AT: RE5R05A]

- b. If one or more pieces of debris are found that are over 1 mm (0.040 in) in size and/or peeled clutch facing material is found in the coffee filter, the A/T fluid cooler is not serviceable. The A/T fluid cooler/radiator must be replaced and the inspection procedure is ended. Refer to [CO-12, "Exploded View"](#).

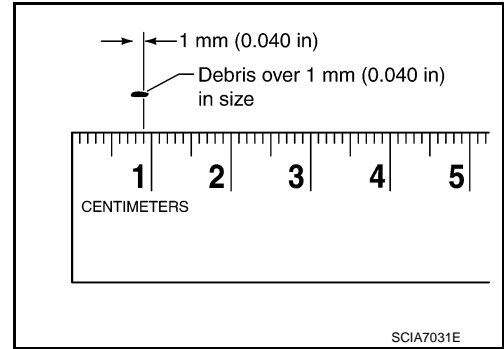

Inspection

INFOID:000000004342996

After performing all procedures, ensure that all remaining oil is cleaned from all components.

A
B
C
TM
E
F
G
H
I
J
K
L
M
N
O
P

STALL TEST

< PERIODIC MAINTENANCE >

[5AT: RE5R05A]

STALL TEST

Inspection and Judgment

INFOID:000000004342997

INSPECTION

1. Inspect the amount of engine oil. Replenish the engine oil if necessary.
2. Drive for about 10 minutes to warm up the vehicle so that the A/T fluid temperature is 50 to 80°C (122 to 176°F). Inspect the amount of ATF. Replenish if necessary.
3. Securely engage the parking brake so that the tires do not turn.
4. Start the engine, apply foot brake, and place selector lever in "D" position.
5. Gradually press down the accelerator pedal while holding down the foot brake.
6. Quickly read off the stall speed, then quickly remove your foot from the accelerator pedal.

CAUTION:

Do not hold down the accelerator pedal for more than 5 seconds during this test.

Stall speed : Refer to [TM-272, "Stall Speed"](#).

7. Shift the selector lever to the "N" position.
 8. Cool down the ATF.
- CAUTION:**
Run the engine at idle for at least 1 minute.
9. Repeat steps 5 through 8 with selector lever in "R" position.

JUDGMENT OF STALL TEST

	Selector lever position		Possible location of malfunction
	"D" and "M"	"R"	
Stall speed	H	O	<ul style="list-style-type: none"> • Forward brake • Forward one-way clutch • 1st one-way clutch • 3rd one-way clutch
	O	H	<ul style="list-style-type: none"> • Reverse brake
	L	L	<ul style="list-style-type: none"> • Engine and torque converter one-way clutch
	H	H	<ul style="list-style-type: none"> • Line pressure low

O: Stall speed within standard value position

H: Stall speed higher than standard value

L: Stall speed lower than standard value

Stall test standard value position

Does not shift-up "D" or "M" position 1 → 2	Slipping in 2GR, 3GR or 4GR	Direct clutch slippage
Does not shift-up "D" or "M" position 2 → 3	Slipping in 3GR, 4GR or 5GR	High and low reverse clutch slippage
Does not shift-up "D" or "M" position 3 → 4	Slipping in 4GR or 5GR	Input clutch slippage
Does not shift-up "D" or "M" position 4 → 5	Slipping in 5GR	Front brake slippage

LINE PRESSURE TEST

< PERIODIC MAINTENANCE >

[5AT: RE5R05A]

LINE PRESSURE TEST

Inspection and Judgment

INFOID:000000004342998

INSPECTION

Line Pressure Test Port

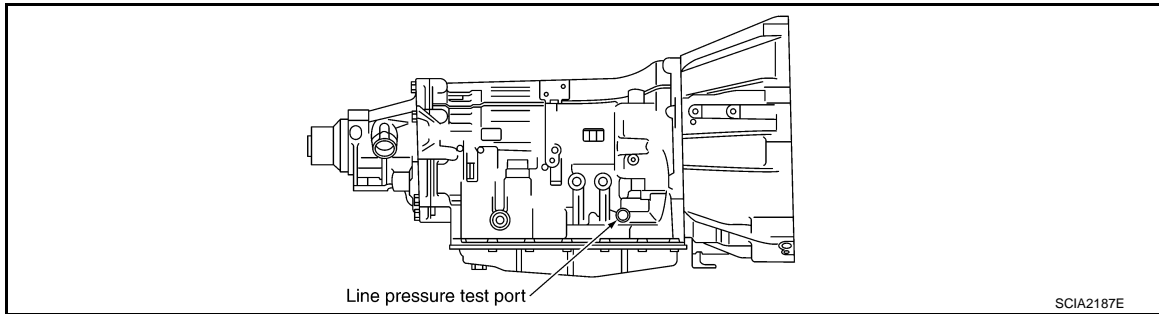

Line Pressure Test Procedure

1. Inspect the amount of engine oil and replenish if necessary.
2. Drive the car for about 10 minutes to warm it up so that the ATF reaches in range of 50 to 80°C (122 to 176°F). Then inspect the amount of ATF and replenish if necessary.

NOTE:

The A/T fluid temperature rises in range of 50 to 80°C (122 to 176°F) during 10 minutes of driving.

3. Remove the front propeller shaft from vehicle (with AWD models). Refer to [DLN-76](#).
4. After warming up remove the oil pressure detection plug and install the oil pressure gauge [SST: ST2505S001(J-34301-C)].

CAUTION:

When using the oil pressure gauge, be sure to use the O-ring attached to the oil pressure detection plug.

5. Securely engage the parking brake so that the tires do not turn.
6. Start the engine, then measure the line pressure at both idle and the stall speed.

CAUTION:

- Keep the brake pedal pressed all the way down during measurement.
- When measuring the line pressure at the stall speed, refer to [TM-148, "Inspection and Judgment"](#).

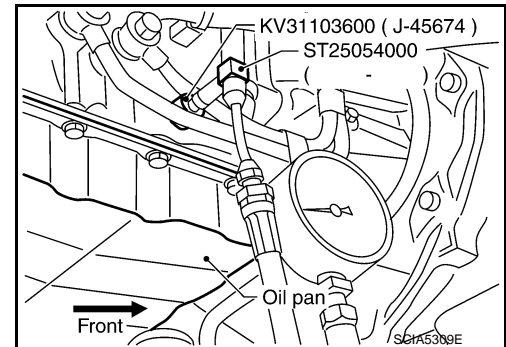

LINE PRESSURE : Refer to [TM-273, "Line Pressure"](#).

7. Install the oil pressure detection plug and tighten to the specified torque after the measurements are complete. Refer to [TM-201, "Exploded View"](#).

CAUTION:

- Never reuse O-ring.
- Apply ATF to O-ring.

JUDGMENT OF LINE PRESSURE TEST

LINE PRESSURE TEST

< PERIODIC MAINTENANCE >

[5AT: RE5R05A]

Judgment		Possible cause
Idle speed	Low for all positions ("P", "R", "N", "D", "M")	<p>Possible causes include malfunctions in the pressure supply system and low oil pump output.</p> <p>For example</p> <ul style="list-style-type: none"> • Oil pump wear • Pressure regulator valve or plug sticking or spring fatigue • Oil strainer ⇒ oil pump ⇒ pressure regulator valve passage oil leak • Engine idle speed too low
	Only low for a specific position	<p>Possible causes include an oil pressure leak in a passage or device related to the position after the pressure is distributed by the manual valve.</p>
	High	<p>Possible causes include a sensor malfunction or malfunction in the line pressure adjustment function.</p> <p>For example</p> <ul style="list-style-type: none"> • Accelerator pedal position signal malfunction • A/T fluid temperature sensor malfunction • Line pressure solenoid malfunction (sticking in OFF state, filter clog, cut line) • Pressure regulator valve or plug sticking
Stall speed	Oil pressure does not rise higher than the oil pressure for idle.	<p>Possible causes include a sensor malfunction or malfunction in the pressure adjustment function.</p> <p>For example</p> <ul style="list-style-type: none"> • Accelerator pedal position signal malfunction • TCM breakdown • Line pressure solenoid malfunction (shorting, sticking in ON state) • Pressure regulator valve or plug sticking • Pilot valve sticking or pilot filter clogged
	The pressure rises, but does not enter the standard position.	<p>Possible causes include malfunctions in the pressure supply system and malfunction in the pressure adjustment function.</p> <p>For example</p> <ul style="list-style-type: none"> • Accelerator pedal position signal malfunction • Line pressure solenoid malfunction (sticking, filter clog) • Pressure regulator valve or plug sticking • Pilot valve sticking or pilot filter clogged
	Only low for a specific position	<p>Possible causes include an oil pressure leak in a passage or device related to the position after the pressure is distributed by the manual valve.</p>

ROAD TEST

Description

INFOID:000000004342999

- The road test inspects overall performance of the A/T and analyzes possible malfunction causes.
- The road test is performed out in the following three stages.

1. [TM-151, "Check Before Engine Is Started"](#).
2. [TM-151, "Check at Idle"](#).
3. Cruise test
 - [TM-152, "Cruise Test - Part 1"](#)
 - [TM-153, "Cruise Test - Part 2"](#)
 - [TM-153, "Cruise Test - Part 3"](#)

CAUTION:**Always drive vehicle at a safe speed.**

- Check the test procedure and inspection items before beginning the road test.
- Test all inspection items until the symptom is uncovered. Diagnose NG items when all road tests are complete.

Check Before Engine Is Started

INFOID:000000004343000

1.CHECK A/T CHECK INDICATOR LAMP

1. Park vehicle on level surface.
2. Shift the selector lever to "P" position.
3. Turn ignition switch OFF and wait at least 10 seconds.
4. Turn ignition switch ON. (Do not start engine.)

Does A/T CHECK indicator lamp light up for about 2 seconds?

- YES >> Go to [TM-151, "Check at Idle"](#).
 NO >> Stop the road test and go to [TM-112, "Symptom Table"](#).

Check at Idle

INFOID:000000004343001

1.CHECK STARTING THE ENGINE

1. Park vehicle on level surface.
2. Shift the selector lever to "P" or "N" position.
3. Turn ignition switch OFF.
4. Start the engine.

Does the engine start?

- YES >> GO TO 2.
 NO >> Stop the road test and go to [TM-112, "Symptom Table"](#).

2.CHECK STARTING THE ENGINE

1. Turn ignition switch ON. (Do not start engine.)
2. Shift the selector lever to "D", "M" or "R" position.
3. Start the engine.

Does the engine start in any positions?

- YES >> Stop the road test and go to [TM-112, "Symptom Table"](#).
 NO >> GO TO 3.

3.CHECK "P" POSITION FUNCTIONS

1. Shift the selector lever to "P" position.
2. Turn ignition switch OFF.
3. Release the parking brake.
4. Push the vehicle forward or backward.
5. Engage the parking brake.

When you push the vehicle while disengaging the parking brake, does it move?

- YES >> Record the malfunction, GO TO 4.
 NO >> GO TO 4.

4.CHECK "N" POSITION FUNCTIONS

1. Start the engine.
2. Shift the selector lever to "N" position.
3. Release the parking brake.

Does vehicle move forward or backward?

- YES >> Record the malfunction, GO TO 5.
 NO >> GO TO 5.

5.CHECK SHIFT SHOCK

1. Engage the brake.
 2. Shift the selector lever to "D" position.
- When the A/T is shifted from "N" to "D", is there an excessive shock?

- YES >> Record the malfunction, GO TO 6.
 NO >> GO TO 6.

6.CHECK "R" POSITION FUNCTIONS

1. Shift the selector lever to "R" position.
2. Release the brake for 4 to 5 seconds.

Does the vehicle creep backward?

- YES >> GO TO 7.
 NO >> Record the malfunction, GO TO 7.

7.CHECK "D" POSITION FUNCTIONS

Inspect whether the vehicle creeps forward when the A/T is put into the "D" position.

Does the vehicle creep forward in the "D" position?

- YES >> Go to [TM-152, "Cruise Test - Part 1"](#).
 NO >> Record the malfunction and go to [TM-152, "Cruise Test - Part 1"](#).

Cruise Test - Part 1

INFOID:000000004343002

1.CHECK STARTING OUT FROM D1

1. Drive the vehicle for about 10 minutes to warm up the engine oil and ATF.
 Appropriate temperature for the ATF: 50 to 80°C (122 to 176°F)
2. Park the vehicle on a level surface.
3. Shift the selector lever to "D" position.
4. Press the accelerator pedal about half-way down to accelerate the vehicle.

Ⓟ With CONSULT-III

Read the value of "GEAR" in "Data Monitor" in "TRANSMISSION".

Starts from D1?

- YES >> GO TO 2.
 NO >> Record the malfunction, GO TO 2.

2.CHECK SHIFT-UP

Depress the accelerator pedal about half-way and inspect if the vehicle shifts up (D1→ D2→ D3→ D4→ D5) at the appropriate speed. Refer to [TM-272, "Vehicle Speed at Which Gear Shifting Occurs"](#).

Ⓟ With CONSULT-III

Read the value of "GEAR", "ACCELE POSI" and "VEHICLE SPEED" in "Data Monitor" in "TRANSMISSION".

Is the inspection result normal?

- YES >> GO TO 3.
 NO >> Record the malfunction, GO TO 3.

3.CHECK LOCK-UP

When releasing accelerator pedal (closed throttle position signal OFF) from D5, check lock-up from D5 to L/U. Refer to [TM-272, "Vehicle Speed at Which Lock-up Occurs/Releases"](#).

Ⓟ With CONSULT-III

Select "TCC SOLENOID" in "Data Monitor" in "TRANSMISSION". Refer to [TM-101, "Reference Value"](#).

ROAD TEST

< PERIODIC MAINTENANCE >

[5AT: RE5R05A]

Does it lock-up?

- YES >> GO TO 4.
NO >> Record the malfunction, GO TO 4.

4.CHECK LOCK-UP HOLD

Check hold lock-up.

With CONSULT-III

Select "TCC SOLENOID" in "Data Monitor" in "TRANSMISSION". Refer to [TM-101, "Reference Value"](#).

Does it maintain lock-up status?

- YES >> GO TO 5.
NO >> Record the malfunction, GO TO 5.

5.CHECK LOCK-UP RELEASE

Check lock-up cancellation by depressing brake pedal lightly to decelerate.

With CONSULT-III

Select "TCC SOLENOID" in "Data Monitor" in "TRANSMISSION". Refer to [TM-101, "Reference Value"](#).

Does lock-up cancel?

- YES >> GO TO 6.
NO >> Record the malfunction, GO TO 6.

6.CHECK SHIFT-DOWN D₅→ D₄

Decelerate by pressing lightly on the brake pedal.

With CONSULT-III

Read the value of "GEAR" and "ENGINE SPEED" in "Data Monitor" in "TRANSMISSION".

When the A/T shift-down D₅→ D₄, does the engine speed drop smoothly back to idle?

- YES >> 1. Stop the vehicle.
2. Go to [TM-153, "Cruise Test - Part 2"](#).
NO >> Record the malfunction and go to [TM-153, "Cruise Test - Part 2"](#).

Cruise Test - Part 2

INFOID:000000004343003

1.CHECK SHIFT-UP

Depress the accelerator pedal down all the way and inspect whether or not the A/T shifts up (D₁→ D₂→ D₃) at the correct speed. Refer to [TM-272, "Vehicle Speed at Which Gear Shifting Occurs"](#).

With CONSULT-III

Read the value of "GEAR", "ACCELE POSI" and "VEHICLE SPEED" in "Data Monitor" in "TRANSMISSION".

Is the inspection result normal?

- YES >> GO TO 2.
NO >> Record the malfunction, GO TO 2.

2.CHECK SHIFT-UP D₃→ D₄ AND ENGINE BRAKE

When the A/T changes speed D₃→ D₄, release the accelerator pedal.

With CONSULT-III

Read the value of "GEAR" in "Data Monitor" in "TRANSMISSION".

Does the A/T shift-up D₃→ D₄ and apply the engine brake?

- YES >> 1. Stop the vehicle.
2. Go to [TM-153, "Cruise Test - Part 3"](#).
NO >> Record the malfunction and go to [TM-153, "Cruise Test - Part 3"](#).

Cruise Test - Part 3

INFOID:000000004343004

1.MANUAL MODE FUNCTION

Shift the selector lever to manual mode from "D" position.

Does it switch to manual mode?

- YES >> GO TO 2.

NO >> Record the malfunction, GO TO 2.

2.CHECK SHIFT-DOWN

During manual mode driving, is downshift from M5 → M4 → M3 → M2 → M1 performed?

④ **With CONSULT-III**

Read the value of "GEAR" and "ENGINE SPEED" in "Data Monitor" in "TRANSMISSION".

Is the inspection result normal?

YES >> GO TO 3.

NO >> Record the malfunction, GO TO 3.

3.CHECK ENGINE BRAKE

Check engine brake.

Does engine braking effectively reduce speed in M1 position?

YES >> Check malfunction phenomena to repair or replace malfunctioning part. Refer to [TM-112. "Symptom Table"](#).

NO >> 1. Record the malfunction.
2. Check malfunction phenomena to repair or replace malfunctioning part. Refer to [TM-112. "Symptom Table"](#).

A/T POSITION

2WD

2WD : Inspection and Adjustment

INFOID:000000004343005

INSPECTION

1. Place selector lever in "P" position, and turn ignition switch ON (engine stop).
2. Check that selector lever can be shifted to other than "P" position when brake pedal is depressed. Also check that selector lever can be shifted from "P" position only when brake pedal is depressed.
3. Shift the selector lever and check for excessive effort, sticking, noise or rattle.
4. Confirm that the selector lever stops at each position by feeling the engagement when it is moved through all the positions. Check whether or not the actual position the selector lever matches the position shown by the shift position indicator and the A/T body.
5. The method of operating the lever to individual positions correctly is shown in the figure.
6. When selector button is pressed in "P", "R", or "N" position without applying forward/backward force to selector lever, check button operation for sticking.
7. Confirm that the back-up lamps illuminate only when lever is placed in the "R" position. Confirm that the back-up lamps does not illuminate when selector lever is pushed against "R" position in the "P" or "N" position.
8. Confirm that the engine can only be started with the selector lever in the "P" and "N" positions. (With selector lever in the "P" position, engine can be started even when selector lever is moved forward and backward.)
9. Make sure that A/T is locked completely in "P" position.
10. DS mode must be indicated on the combination meter when the selector lever is shifted to the manual shift gate. When the selector lever is shifted to the "+" or "-" side in the DS mode, manual mode should be indicated on the combination meter.
In addition, a set shift position must be changed when the selector lever is shifted to the "+" or "-" side in the manual mode. (Only while driving.)

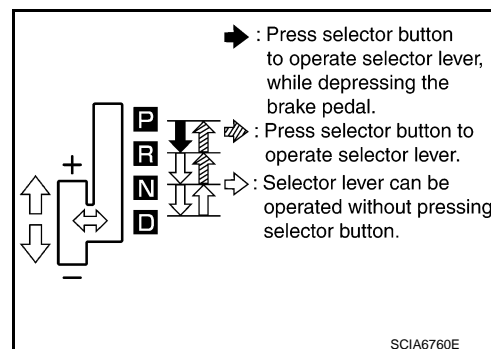

ADJUSTMENT

1. Loosen nut (1) of pivot pin (1).
2. Place transmission range switch and selector lever in "P" position.
3. While pressing lower lever (A) of A/T shift selector assembly toward rear of vehicle (in "P" position direction), tighten nut to specified torque. Refer to [TM-157](#). "2WD : Exploded View".

CAUTION:

Be careful not to touch the control rod while pressing lower lever of A/T shift selector assembly.

NOTE:

Press lower lever of A/T shift selector assembly with a force of approximately 9.8 N (approximately 1 kg, 2.2 lb).

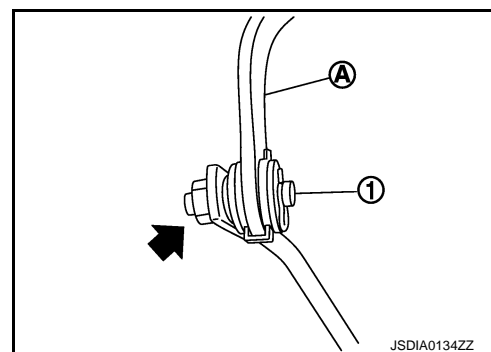

AWD

AWD : Inspection and Adjustment

INFOID:000000004343006

INSPECTION

1. Place selector lever in "P" position, and turn ignition switch ON (engine stop).
2. Check that selector lever can be shifted to other than "P" position when brake pedal is depressed. Also check that selector lever can be shifted from "P" position only when brake pedal is depressed.
3. Shift the selector lever and check for excessive effort, sticking, noise or rattle.

A/T POSITION

< PERIODIC MAINTENANCE >

[5AT: RE5R05A]

- Confirm that the selector lever stops at each position by feeling the engagement when it is moved through all the positions. Check whether or not the actual position the selector lever matches the position shown by the shift position indicator and the A/T body.
- The method of operating the lever to individual positions correctly is shown in the figure.
- When selector button is pressed in "P", "R", or "N" position without applying forward/backward force to selector lever, check button operation for sticking.
- Confirm that the back-up lamps illuminate only when lever is placed in the "R" position. Confirm that the back-up lamps do not illuminate when selector lever is pushed against "R" position in the "P" or "N" position.
- Confirm that the engine can only be started with the selector lever in the "P" and "N" positions. (With selector lever in the "P" position, engine can be started even when selector lever is moved forward and backward.)
- Make sure that A/T is locked completely in "P" position.
- DS mode must be indicated on the combination meter when the selector lever is shifted to the manual shift gate. When the selector lever is shifted to the "+" or "-" side in the DS mode, manual mode should be indicated on the combination meter.
In addition, a set shift position must be changed when the selector lever is shifted to the "+" or "-" side in the manual mode. (Only while driving.)

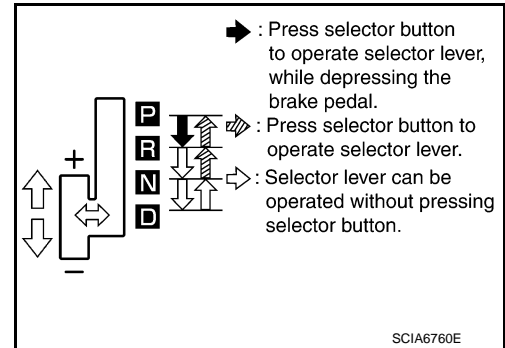

ADJUSTMENT

- Loosen nut (←) of pivot pin (1).
- Place transmission range switch and selector lever in "P" position.
- While pressing lower lever (A) of A/T shift selector assembly toward rear of vehicle (in "P" position direction), tighten nut to specified torque. Refer to [TM-160, "AWD : Exploded View"](#).

CAUTION:

Be careful not to touch the control rod while pressing lower lever of A/T shift selector assembly.

NOTE:

Press lower lever of shift selector assembly with a force of approximately 9.8 N (approximately 1 kg, 2.2 lb).

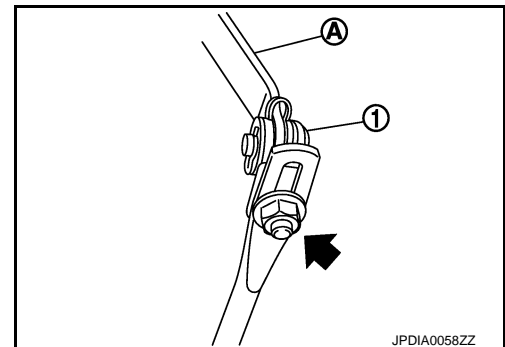

A/T SHIFT SELECTOR

< REMOVAL AND INSTALLATION >

[5AT: RE5R05A]

- | | | |
|------------------------|--------------------------------------|---------------------------------|
| 1. Selector lever knob | 2. Lock pin | 3. Console finisher |
| 4. Ashtray (front) | 5. Selector lever position indicator | 6. Harness connector |
| 7. Insert finisher | 8. Dust cover plate | 9. Dust cover |
| 10. Bracket | 11. Control rod | 12. Pivot pin |
| 13. Plain washer | 14. Collar | 15. Snap pin |
| 16. Insulator | 17. Shift lock unit | 18. A/T shift selector assembly |
| 19. Adapter | | |

 : Apply multi-purpose grease.

Refer to [GI-4, "Components"](#) for symbols not described on the above.

2WD : Removal and Installation

INFOID:000000004343008

REMOVAL

1. Remove control rod from A/T shift selector assembly.
2. Shift the selector lever to "N" position.
3. Remove knob cover (A) below selector lever downward.
4. Pull lock pin (1) out of selector lever knob (2).
5. Remove selector lever knob.
6. Remove console finisher assembly and center console assembly. Refer to [IP-23, "Exploded View"](#).
CAUTION:
when disconnecting selector lever position indicator connector from shift position switch, never twist or apply an excessive load to the connector.
7. Remove the rear ventilator duct 1 (with rear ventilation). Refer to [VTL-11, "Exploded View"](#).
8. Disconnect A/T shift selector harness connector and harness clips.
9. Remove A/T shift selector assembly mounting bolts.
10. Remove A/T shift selector assembly.
11. Remove selector lever position indicator from console finisher assembly.
 - a. Remove ashtray (front) (1) from console finisher assembly.

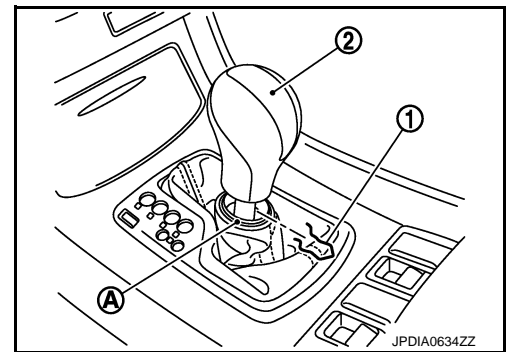

 : Screw

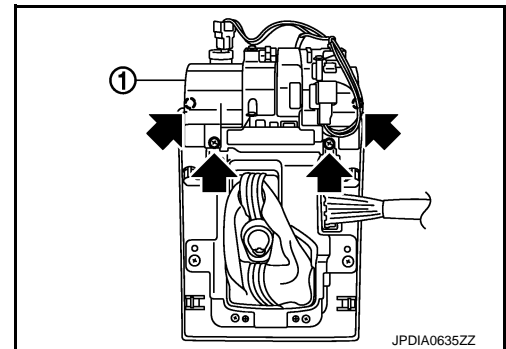

- b. Remove insert finisher (1) from console finisher assembly.

A : Screw (small)

B : Screw (large)

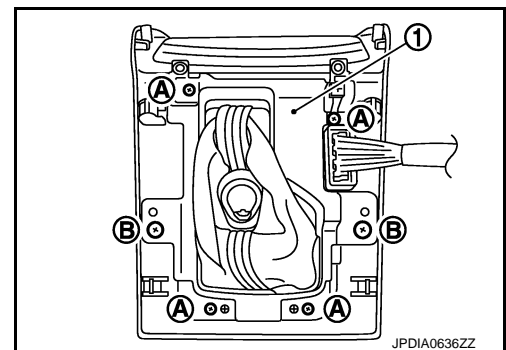

A/T SHIFT SELECTOR

< REMOVAL AND INSTALLATION >

[5AT: RE5R05A]

- c. Remove the selector lever position indicator (1).

← : Screw

12. Remove harness connector from selector lever position indicator.
13. Remove adapter from A/T shift selector assembly.
14. Remove dust cover and dust cover plate from A/T shift selector assembly.
15. Remove dust cover plate from dust cover.
16. Remove shift lock unit from A/T shift selector assembly.
17. Remove bracket from vehicle floor panel.

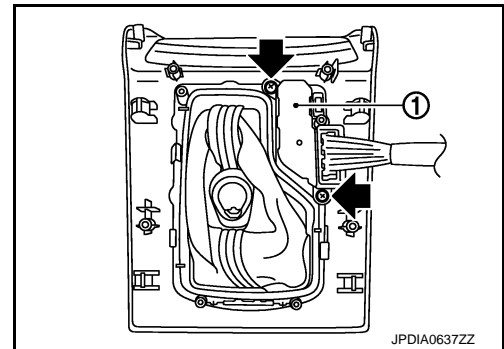

INSTALLATION

Note the following, and install in the reverse order of removal.

CAUTION:

Apply multi-purpose grease on the surface that the shift lock unit plate slides vertically.

- When installing control rod to A/T shift selector assembly, refer to "ADJUSTMENT". Refer to [TM-155. "2WD : Inspection and Adjustment"](#).

2WD : Inspection

INFOID:000000004343009

INSPECTION AFTER INSTALLATION

Check A/T positions. Refer to [TM-155. "2WD : Inspection and Adjustment"](#).

AWD

A
B
C
TM
E
F
G
H
I
J
K
L
M
N
O
P

A/T SHIFT SELECTOR

< REMOVAL AND INSTALLATION >

[5AT: RE5R05A]

- | | | |
|------------------|---------------------|---------------------------------|
| 13. Plain washer | 14. Collar | 15. Pivot pin |
| 16. Insulator | 17. Shift lock unit | 18. A/T shift selector assembly |
| 19. Adapter | | |

 : Apply multi-purpose grease.

Refer to [GI-4, "Components"](#) for symbols not described on the above.

AWD : Removal and Installation

INFOID:000000004343011

REMOVAL

1. Remove control rod from A/T shift selector assembly.
2. Shift the selector lever to "N" position.
3. Remove knob cover (A) below selector lever downward.
4. Pull lock pin (1) out of selector lever knob (2).
5. Remove selector lever knob.
6. Remove console finisher assembly and center console assembly. Refer to [IP-23, "Exploded View"](#).
CAUTION:
When disconnecting selector lever position indicator connector from shift position switch, never twist or apply an excessive load to the connector.
7. Remove the rear ventilator duct 1 (with rear ventilation). Refer to [VTL-11, "Exploded View"](#).
8. Disconnect A/T shift selector harness connector.
9. Remove harness clips from A/T shift selector assembly.
10. Shift the selector lever to "P" position.
11. Move passenger's seat to the end.
12. Remove A/T shift selector assembly mounting bolts.
13. Slightly lift the A/T shift selector assembly (1) and slide it rightward. Then pull it out in the diagonally right direction.

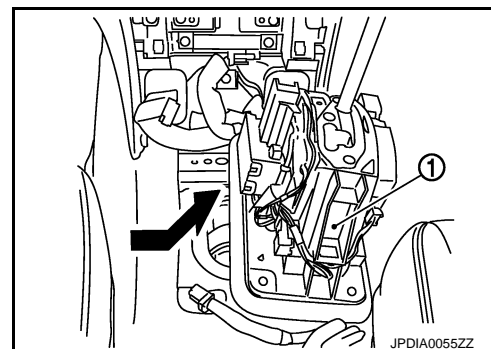
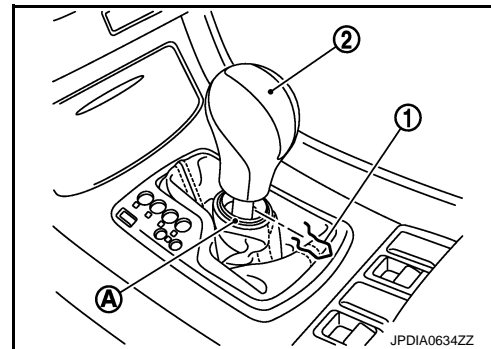

14. Remove selector lever position indicator from console finisher assembly.
 - a. Remove ashtray (front) (1) from console finisher assembly.

 : Screw

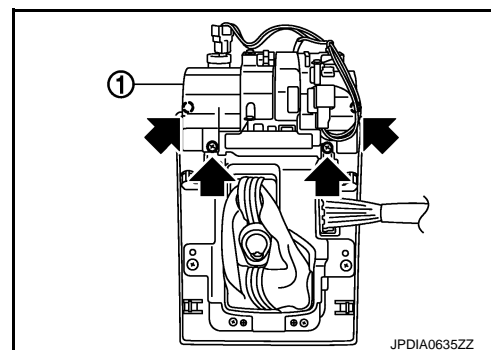

A
B
C
TM
E
F
G
H
I
J
K
L
M
N
O
P

A/T SHIFT SELECTOR

< REMOVAL AND INSTALLATION >

[5AT: RE5R05A]

b. Remove insert finisher (1) from console finisher assembly.

- A : Screw (small)
- B : Screw (large)

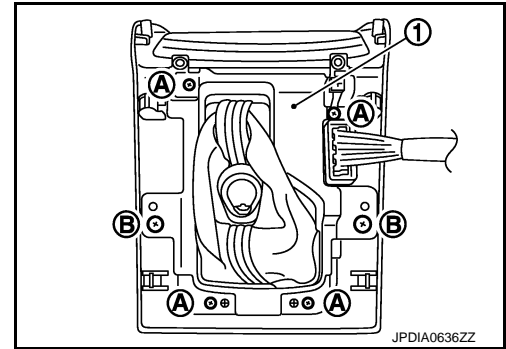

c. Remove the selector lever position indicator (1).

- ← : Screw

15. Remove adapter from A/T shift selector assembly.
16. Remove dust cover and dust cover plate from A/T shift selector assembly.
17. Remove dust cover plate from dust cover.
18. Remove shift lock unit from A/T shift selector assembly.
19. Remove bracket from vehicle floor panel.

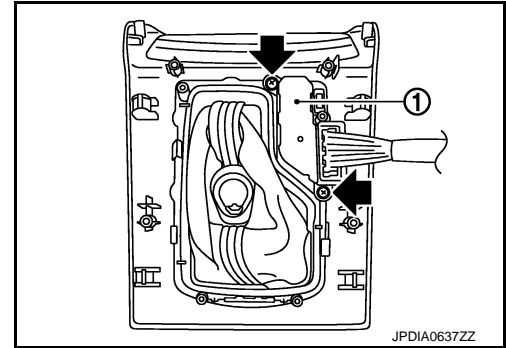

INSTALLATION

Note the following, and install in the reverse order of removal.

CAUTION:

- Apply multi-purpose grease on the pin surface (that slides after installing a collar) of pivot pin.
- Apply multi-purpose grease on the surface that the shift lock unit plate slides vertically.
- When installing control rod to A/T shift selector assembly, refer to "ADJUSTMENT". Refer to [TM-155, "AWD : Inspection and Adjustment"](#).

AWD : Inspection

INFOID:000000004343012

INSPECTION AFTER INSTALLATION

Check A/T positions. Refer to [TM-155, "AWD : Inspection and Adjustment"](#).

CONTROL ROD

< REMOVAL AND INSTALLATION >

[5AT: RE5R05A]

CONTROL ROD

Exploded View

INFOID:000000004343013

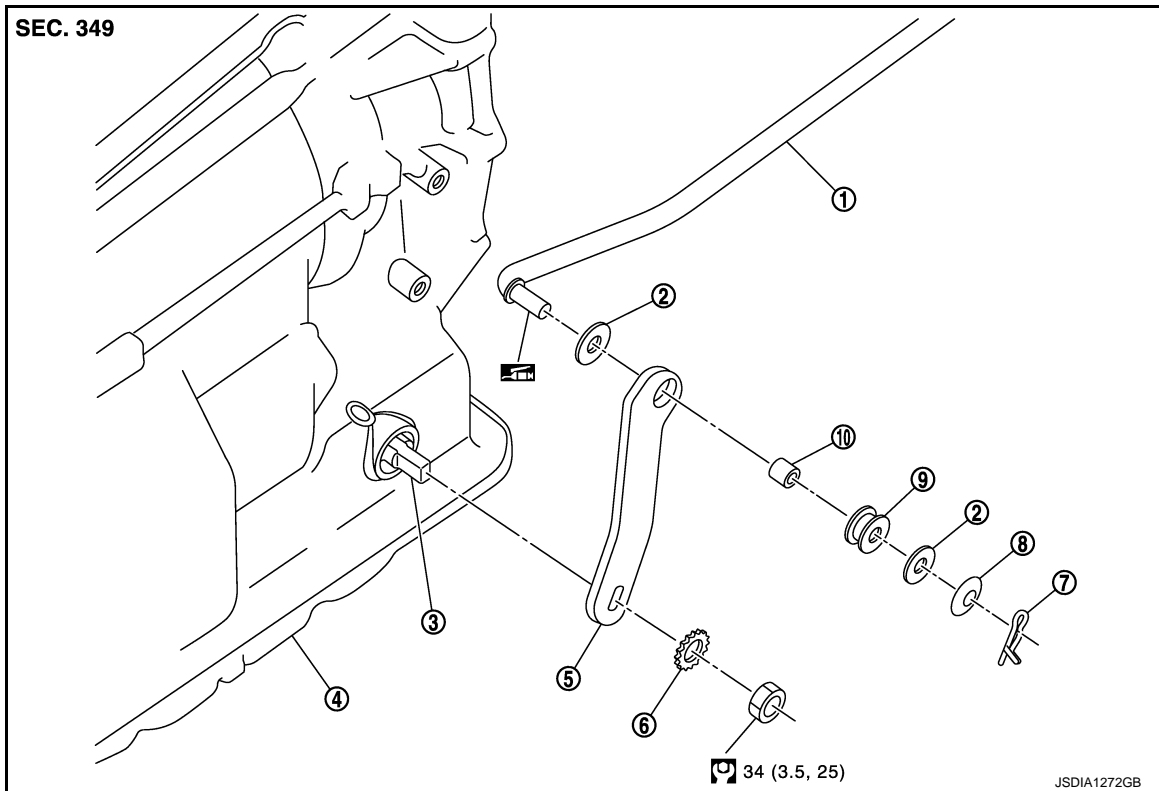

- | | | |
|-----------------|-------------------|-----------------|
| 1. Control rod | 2. Plain washer | 3. Manual shaft |
| 4. A/T assembly | 5. Manual lever | 6. Washer |
| 7. Snap pin | 8. Conical washer | 9. Insulator |
| 10. Collar | | |

 : Apply multi-purpose grease.

Refer to [GI-4. "Components"](#) for symbols not described on the above.

Removal and Installation

INFOID:000000004343014

REMOVAL

1. Remove control rod from A/T shift selector assembly. Refer to [TM-157. "2WD : Exploded View"](#) (2WD models), [TM-160. "AWD : Exploded View"](#) (AWD models).
2. Remove manual lever from A/T assembly.
3. Remove control rod from manual lever.

INSTALLATION

Note the following, and install in the reverse order of removal.

CAUTION:

Apply multi-purpose grease on the pin surface (that slides after installing collar) of the tip of the control rod.

- When installing control rod to A/T shift selector assembly, refer to "ADJUSTMENT". Refer to [TM-155. "2WD : Inspection and Adjustment"](#) (2WD models), [TM-155. "AWD : Inspection and Adjustment"](#) (AWD models).

Inspection and Adjustment

INFOID:000000004343015

ADJUSTMENT AFTER INSTALLATION

CONTROL ROD

< REMOVAL AND INSTALLATION >

[5AT: RE5R05A]

Adjust A/T position. Refer to [TM-155. "2WD : Inspection and Adjustment"](#) (2WD models), [TM-155. "AWD : Inspection and Adjustment"](#) (AWD models).

INSPECTION AFTER INSTALLATION

Check A/T positions. Refer to [TM-155. "2WD : Inspection and Adjustment"](#) (2WD models), [TM-155. "AWD : Inspection and Adjustment"](#) (AWD models).

CONTROL VALVE WITH TCM

< REMOVAL AND INSTALLATION >

[5AT: RE5R05A]

CONTROL VALVE WITH TCM

Exploded View

INFOID:000000004343016

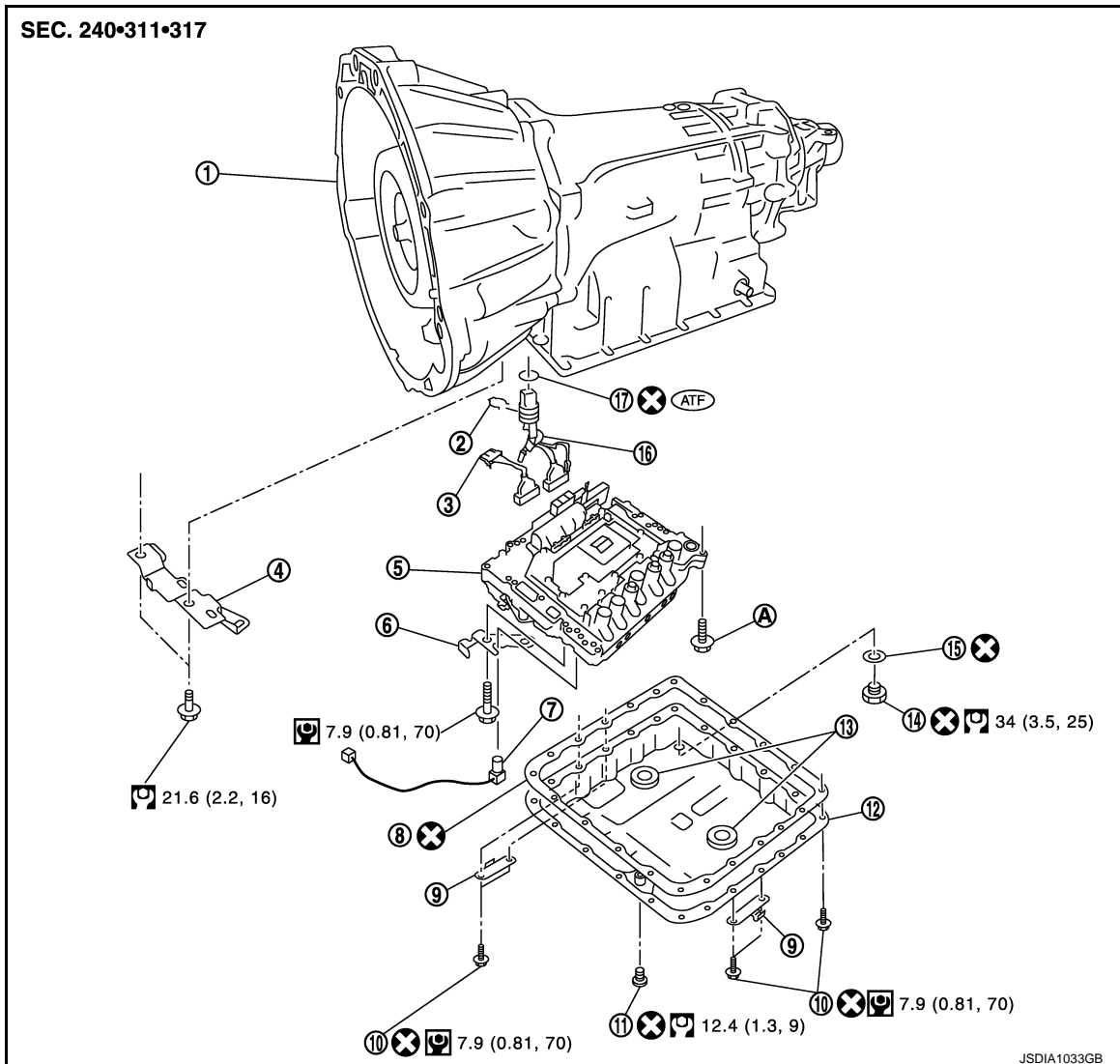

- | | | |
|-----------------------------------|---------------------------|-----------------------|
| 1. A/T | 2. Snap ring | 3. Sub-harness |
| 4. Bracket | 5. Control valve with TCM | 6. Bracket |
| 7. A/T fluid temperature sensor 2 | 8. Oil pan gasket | 9. Clip |
| 10. Oil pan mounting bolt | 11. Overflow plug | 12. Oil pan |
| 13. Magnet | 14. Drain plug | 15. Drain plug gasket |
| 16. Terminal cord assembly | 17. O-ring | |

A. For tightening torque, refer to "Installation".

Refer to [GI-4. "Components"](#) for symbols in the figure.

Removal and Installation

INFOID:000000004343017

REMOVAL

1. Disconnect the battery cable from the negative terminal.
2. Drain ATF through drain plug.
3. Remove exhaust mounting bracket. Refer to [EX-5. "Exploded View"](#).

CONTROL VALVE WITH TCM

< REMOVAL AND INSTALLATION >

[5AT: RE5R05A]

4. Disconnect heated oxygen sensor 2 connectors (A).

⇐ : Vehicle front

← : Bolt

5. Remove heated oxygen sensor 2 harness (B) from clips (1).
6. Remove bracket (2) from transmission assembly.
7. Disconnect A/T assembly connector.

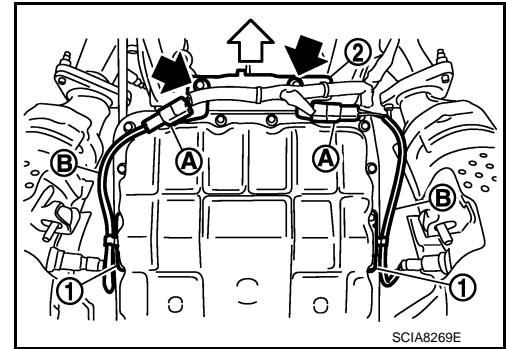

8. Remove snap ring (1) from A/T assembly connector (A).

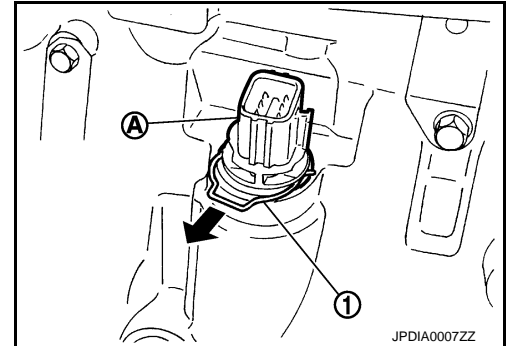

9. Push A/T assembly connector (A).

CAUTION:
Be careful not to damage connector.

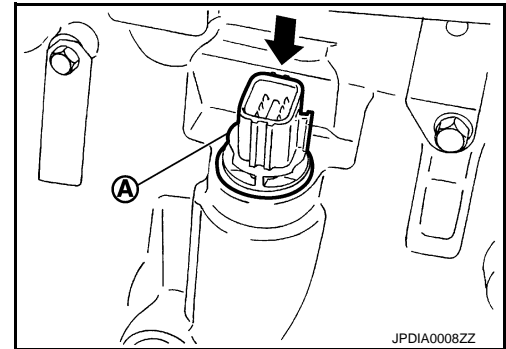

10. Remove clips (1).

11. Remove oil pan (2) and oil pan gasket.

⇐ : Vehicle front

← : Oil pan mounting bolt

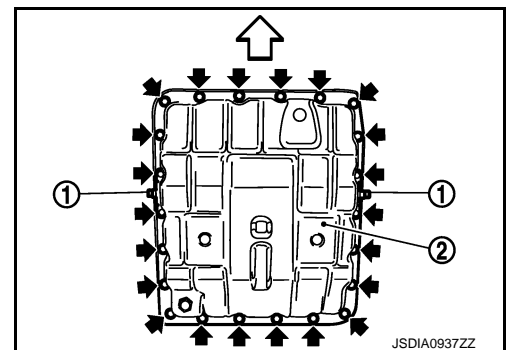

12. Remove magnets (1) from oil pan.

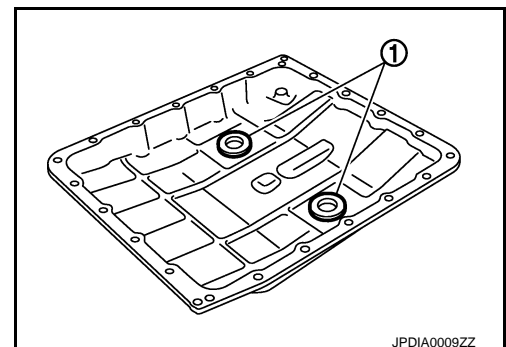

CONTROL VALVE WITH TCM

[5AT: RE5R05A]

< REMOVAL AND INSTALLATION >

13. Disconnect A/T fluid temperature sensor 2 connector (A).

CAUTION:

Be careful not to damage connector.

14. Disengage terminal clips (←).

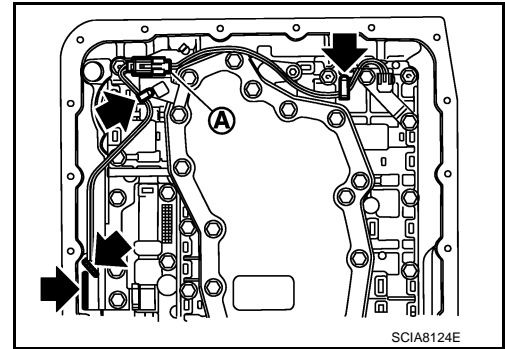

15. Disconnect output speed sensor connector (A).

CAUTION:

Be careful not to damage connector.

16. Disengage terminal clip (←).

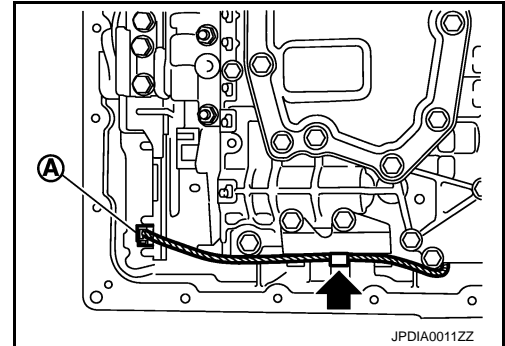

17. Remove bolts (A), (B) and (C) from control valve with TCM.

← : Vehicle front

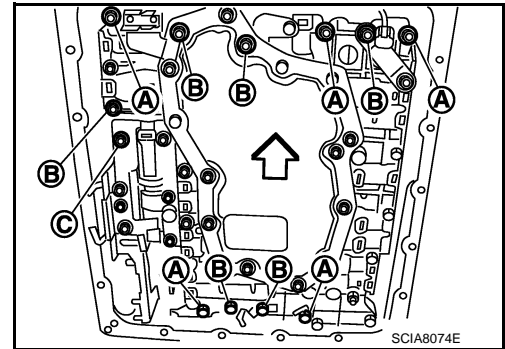

18. Remove control valve with TCM from transmission case.

CAUTION:

When removing, be careful with the manual valve (1) notch and manual plate (2) height. Remove it vertically.

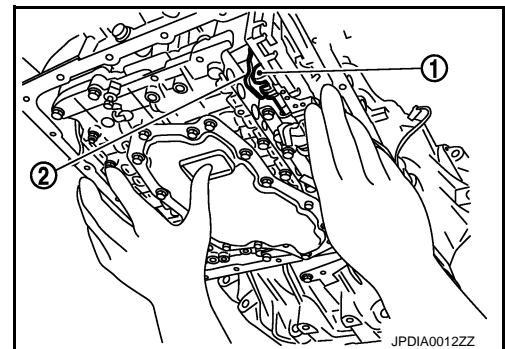

19. Remove A/T fluid temperature sensor 2 (1) with bracket (2) from control valve with TCM.

← : Bolt

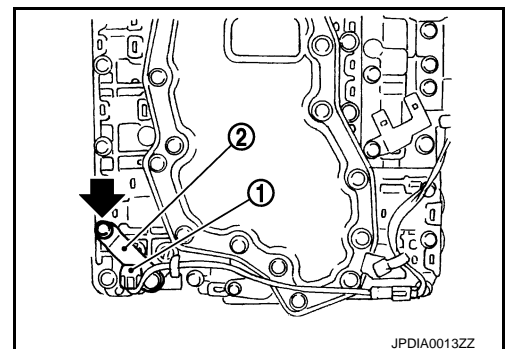

A
B
C
TM
E
F
G
H
I
J
K
L
M
N
O
P

CONTROL VALVE WITH TCM

< REMOVAL AND INSTALLATION >

[5AT: RE5R05A]

20. Remove bracket (1) from A/T fluid temperature sensor 2 (2).

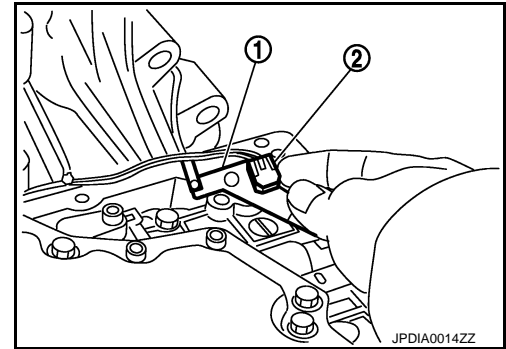

21. Remove O-ring (1) from A/T assembly connector (A).

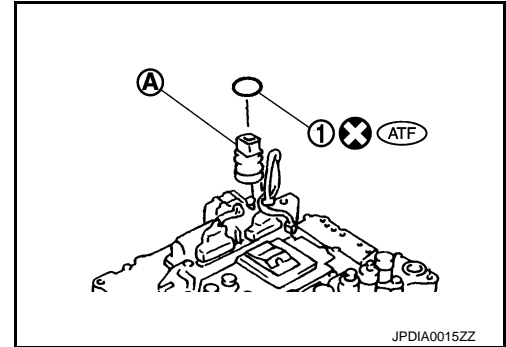

22. Disconnect TCM connectors (A) and (B).

CAUTION:
Be careful not to damage connectors.

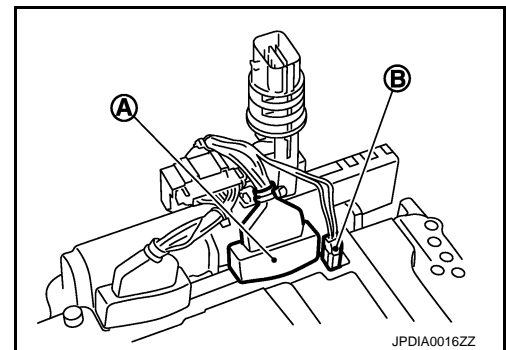

23. Remove A/T assembly connector (A) from control valve with TCM with flat-blade screwdriver (B).

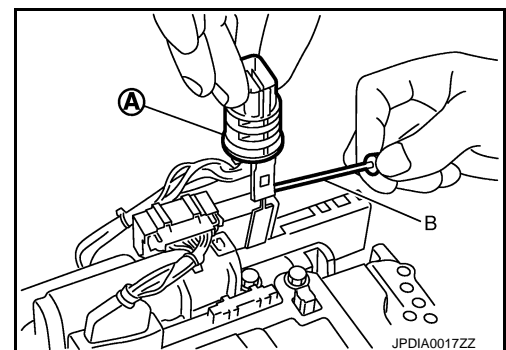

24. Disconnect TCM connector (A) and transmission range switch connector (B).

CAUTION:
Be careful not to damage connectors.

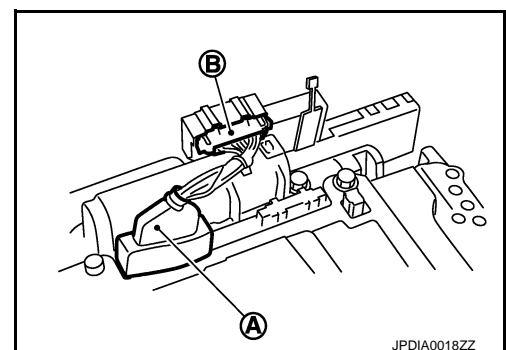

CONTROL VALVE WITH TCM

< REMOVAL AND INSTALLATION >

[5AT: RE5R05A]

INSTALLATION

Note the following, and install in the reverse order of removal.

CAUTION:

- Be careful not to damage connector when installing any connector.
- Never reuse drain plug and drain plug gasket.
- Never reuse O-ring.
- Apply ATF to O-ring.
- Adjust bolt hole of bracket to bolt hole of control valve with TCM when installing A/T fluid temperature sensor 2 (with bracket).
- Refer to the followings when installing control valve with TCM to transmission case.

CAUTION:

- Make sure that input speed sensor securely installs input speed sensor holes (B).

A : Brake band

- Hang down output speed sensor harness toward outside so as not to disturb installation of control valve with TCM.
- Adjust A/T assembly harness connector of control valve with TCM to terminal hole of transmission case.

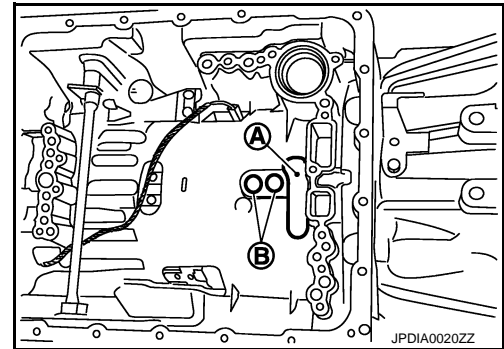

- Assemble it so that manual valve (1) cutout is engaged with manual plate (2) projection.

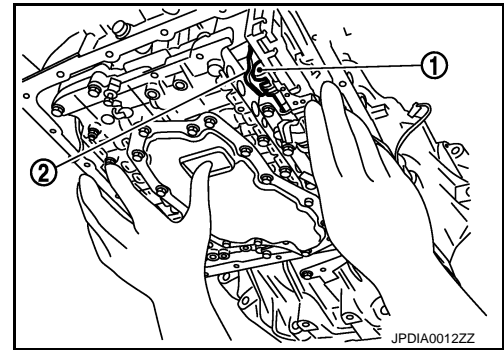

- Install bolts (A), (B) and (C) to control valve with TCM. Tighten bolt 1, 2 and 3 temporarily to prevent dislocation. After that tighten them in order (1 → 2 → 3), and then tighten other bolts. Tighten control valve with TCM bolts to the specified torque.

← : Vehicle front

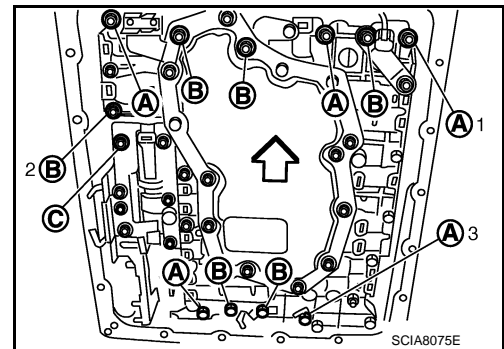

Bolt symbol	A	B	C
Number of bolts	5	6	1
Length mm (in)	42 (1.65)	55 (2.17)	40 (1.57)
Tightening torque N·m (kg·m, in·lb)	7.9 (0.81, 70)		With ATF applied 7.9 (0.81, 70)

CONTROL VALVE WITH TCM

< REMOVAL AND INSTALLATION >

[5AT: RE5R05A]

- Refer to the followings when installing oil pan (2) (with oil pan gasket) and clips (1) to transmission case.

↔ : Vehicle front

← : Oil pan mounting bolt

CAUTION:

- Never reuse oil pan gasket and oil pan mounting bolts.
 - Install oil pan gasket in the direction to align hole position.
 - Install it so that drain plug comes to the position as shown in the figure.
 - Be careful not to pinch harnesses.
 - Completely remove all moisture, oil and old gasket, etc. from oil pan mounting surface.
- Tighten oil pan mounting bolts to the specified torque in numerical order shown in the figure after temporarily tightening them. Tighten oil pan mounting bolts to the specified torque.

↔ : Vehicle front

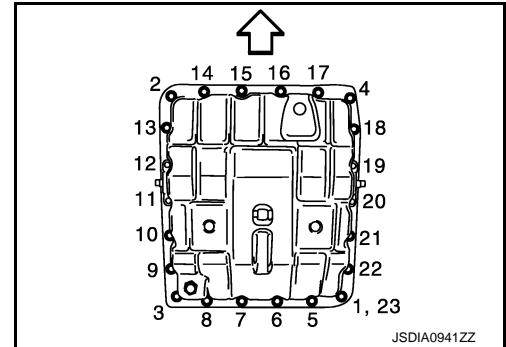
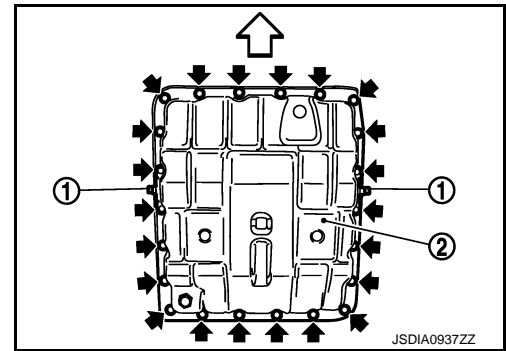

Inspection

INFOID:000000004343018

INSPECTION AFTER REMOVAL

Check foreign materials in oil pan to help determine causes of malfunction. If the ATF is very dark, smells burned, or contains foreign particles, the frictional material (clutches, band) may need replacement. A tacky film that will not wipe clean indicates varnish build up. Varnish can cause valves, servo, and clutches to stick and can inhibit pump pressure.

- If frictional material is detected, perform A/T fluid cooler cleaning. Refer to [TM-145, "Cleaning"](#).

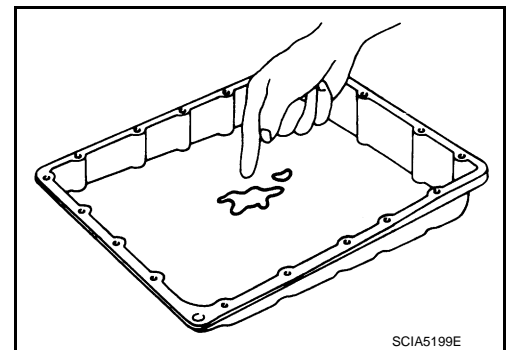

INSPECTION AFTER INSTALLATION

Check for A/T fluid leakage.

A/T FLUID TEMPERATURE SENSOR 2

< REMOVAL AND INSTALLATION >

[5AT: RE5R05A]

A/T FLUID TEMPERATURE SENSOR 2

Exploded View

INFOID:000000004343019

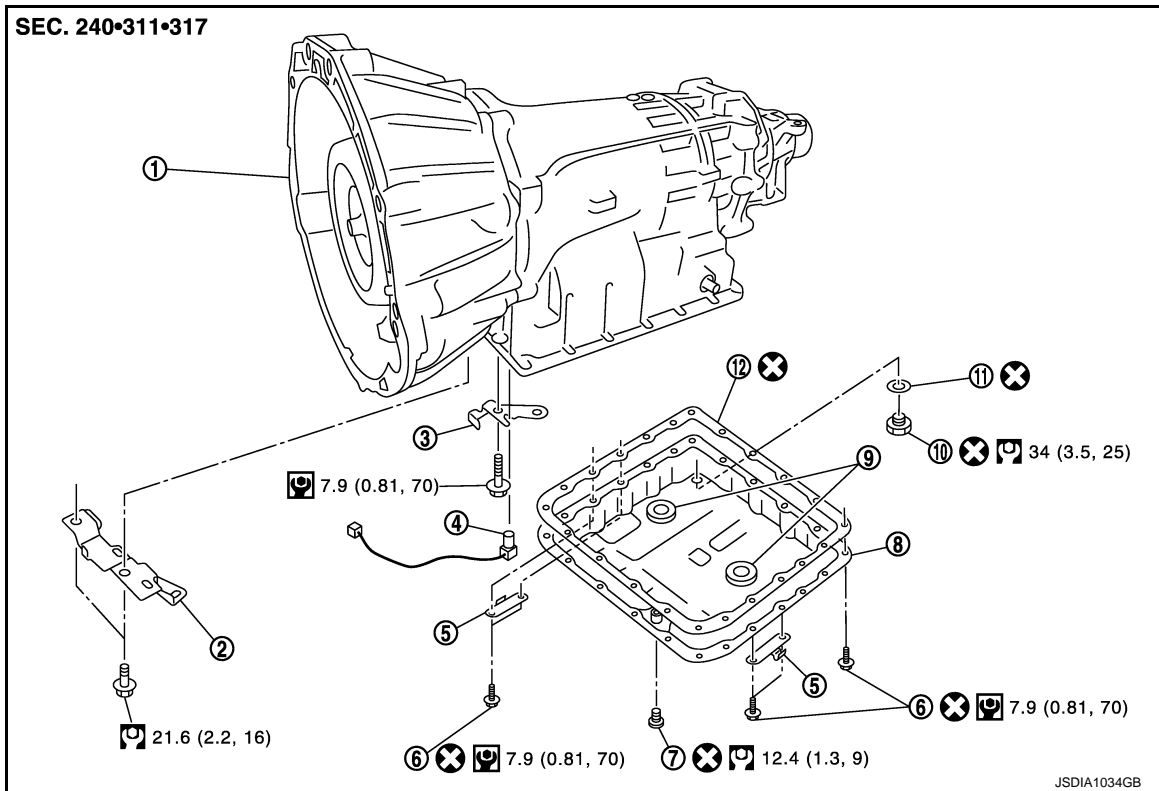

- | | | |
|-----------------------------------|-----------------------|--------------------------|
| 1. A/T | 2. Bracket | 3. Bracket |
| 4. A/T fluid temperature sensor 2 | 5. Clip | 6. Oil pan mounting bolt |
| 7. Overflow plug | 8. Oil pan | 9. Magnet |
| 10. Drain plug | 11. Drain plug gasket | 12. Oil pan gasket |

Refer to [GI-4. "Components"](#) for symbols in the figure.

Removal and Installation

INFOID:000000004343020

REMOVAL

1. Disconnect the battery cable from the negative terminal.
2. Drain ATF through drain plug.
3. Remove exhaust mounting bracket. Refer to [EX-5. "Exploded View"](#).
4. Disconnect heated oxygen sensor 2 connectors (A).

↔ : Vehicle front

← : Bolt

5. Remove heated oxygen sensor 2 harness (B) from clips (1).
6. Remove bracket (2) from transmission assembly.

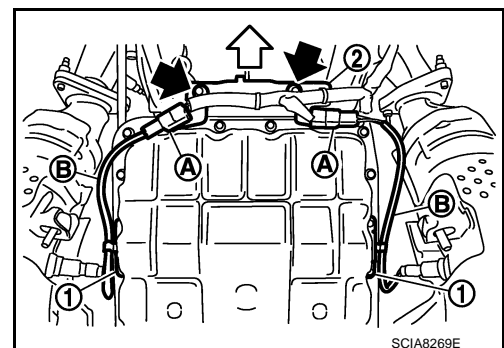

A/T FLUID TEMPERATURE SENSOR 2

< REMOVAL AND INSTALLATION >

[5AT: RE5R05A]

7. Remove clips (1).
8. Remove oil pan (2) and oil pan gasket.

↔ : Vehicle front

← : Oil pan mounting bolt

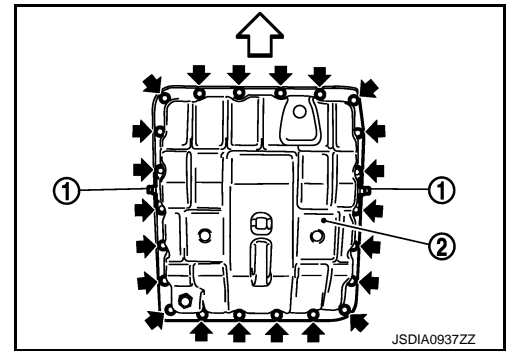

9. Remove magnets (1) from oil pan.

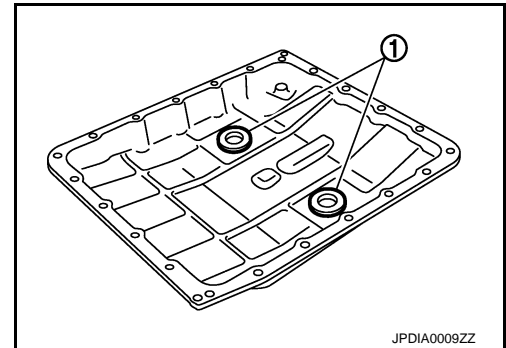

10. Disconnect A/T fluid temperature sensor 2 connector (A).

CAUTION:

Be careful not to damage connector.

11. Disengage terminal clip (←).

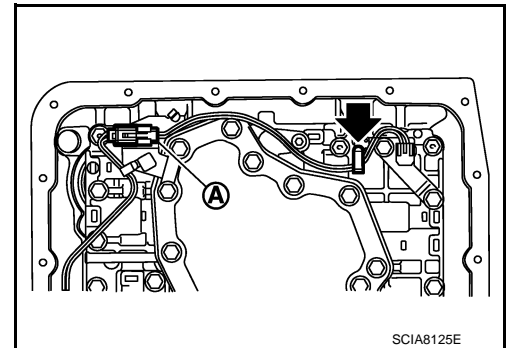

12. Remove A/T fluid temperature sensor 2 (1) with bracket (2) from control valve with TCM.

← : Bolt

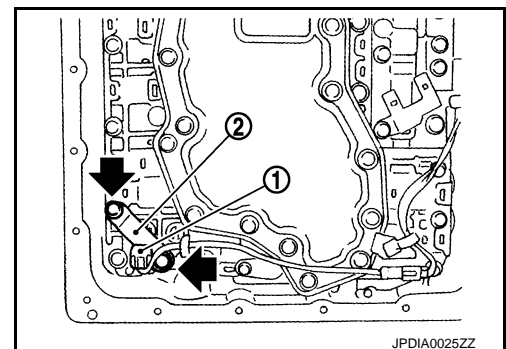

13. Remove bracket (1) from A/T fluid temperature sensor 2 (2).

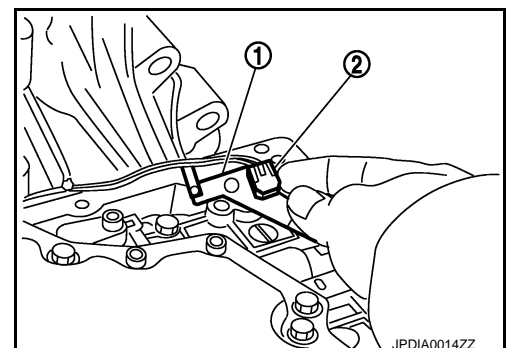

A/T FLUID TEMPERATURE SENSOR 2

< REMOVAL AND INSTALLATION >

[5AT: RE5R05A]

INSTALLATION

Note the following, and install in the reverse order of removal.

CAUTION:

- Be careful not to damage connector.
- Never reuse drain plug and drain plug gasket.
- Adjust bolt hole of bracket to bolt hole of control valve with TCM when installing A/T fluid temperature sensor 2 (with bracket).
- Refer to the following when installing oil pan (2) (with oil pan gasket) and clips (1) to transmission case.

⇐ : Vehicle front

⇐ : Oil pan mounting bolt

CAUTION:

- Never reuse oil pan gasket and oil pan mounting bolts.
 - Install oil pan gasket in the direction to align hole position.
 - Install it so that drain plug comes to the position as shown in the figure.
 - Be careful not to pinch harnesses.
 - Completely remove all moisture, oil and old gasket, etc. from oil pan mounting surface.
- Tighten oil pan mounting bolts to the specified torque in numerical order shown in the figure after temporarily tightening them. Tighten oil pan mounting bolts to the specified torque.

⇐ : Vehicle front

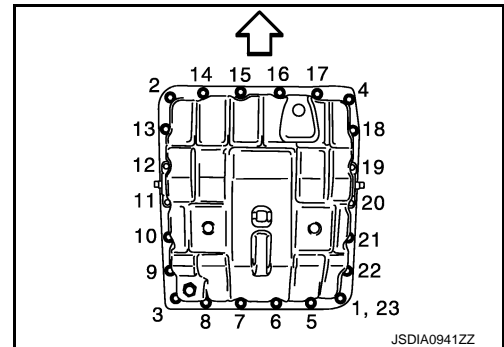
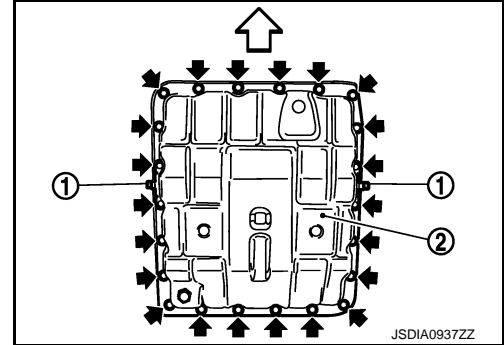

INFOID:000000004343021

Inspection

INSPECTION AFTER REMOVAL

Check foreign materials in oil pan to help determine causes of malfunction. If the ATF is very dark, smells burned, or contains foreign particles, the frictional material (clutches, band) may need replacement. A tacky film that will not wipe clean indicates varnish build up. Varnish can cause valves, servo, and clutches to stick and can inhibit pump pressure.

- If frictional material is detected, perform A/T fluid cooler cleaning. Refer to [TM-145, "Cleaning"](#).

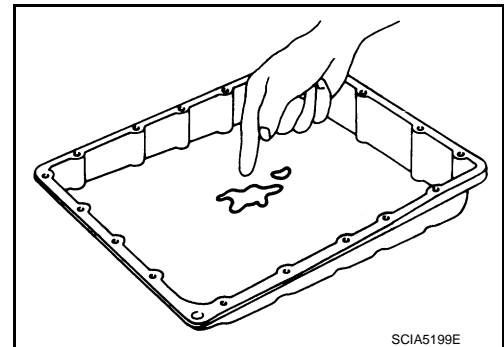

INSPECTION AFTER INSTALLATION

Check A/T fluid leakage.

PARKING COMPONENTS

< REMOVAL AND INSTALLATION >

[5AT: RE5R05A]

PARKING COMPONENTS

2WD

2WD : Exploded View

INFOID:000000004343022

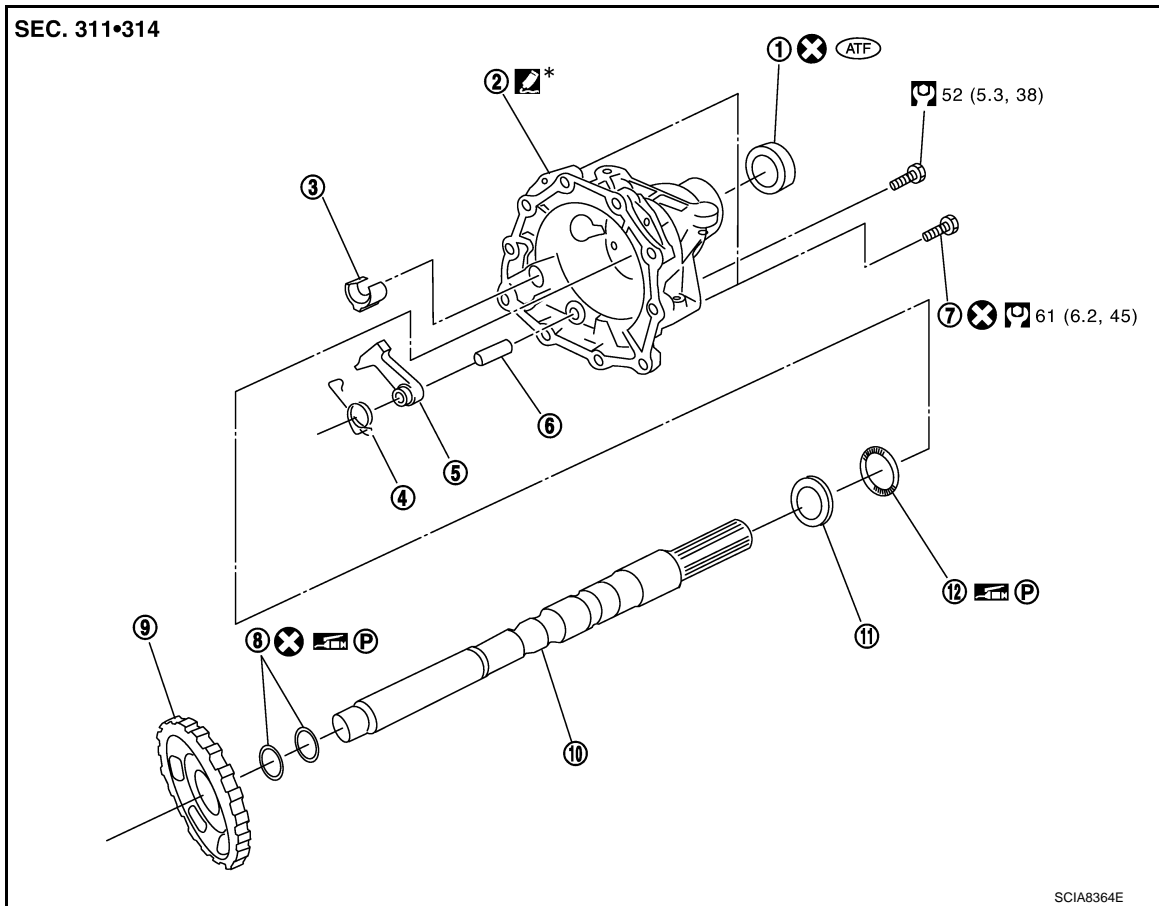

- | | | |
|----------------------|-------------------|-----------------------------|
| 1. Rear oil seal | 2. Rear extension | 3. Parking actuator support |
| 4. Return spring | 5. Parking pawl | 6. Pawl shaft |
| 7. Self-sealing bolt | 8. Seal ring | 9. Parking gear |
| 10. Output shaft | 11. Bearing race | 12. Needle bearing |

: Apply Genuine Anaerobic Liquid Gasket or equivalent. Refer to [GI-17, "Recommended Chemical Products and Sealants"](#).
Refer to [GI-4, "Components"](#) for symbols not described on the above.

2WD : Removal and Installation

INFOID:000000004343023

REMOVAL

1. Drain ATF through drain plug.
2. Remove exhaust front tube and center muffler with power tool. Refer to [EX-5, "Exploded View"](#).
3. Remove rear propeller shaft. Refer to [DLN-82, "Exploded View"](#).
4. Remove control rod. Refer to [TM-163, "Exploded View"](#).
5. Support A/T assembly with a transmission jack.
CAUTION:
When setting transmission jack, be careful not to allow it to collide against the drain plug.
6. Remove rear engine mounting member with power tool. Refer to [EM-79, "2WD : Exploded View"](#).
7. Remove engine mounting insulator (rear). Refer to [EM-79, "2WD : Exploded View"](#).

PARKING COMPONENTS

< REMOVAL AND INSTALLATION >

[5AT: RE5R05A]

8. Remove tightening bolts for rear extension assembly and transmission case.

1 : Self-sealing bolt

A : Bolt

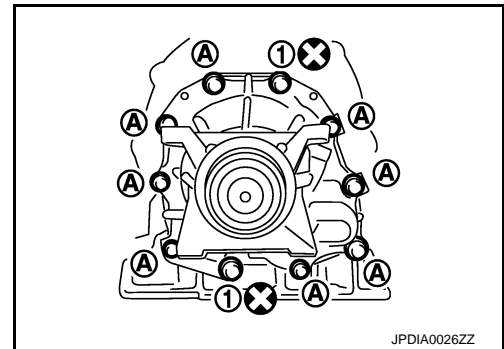

9. Tap rear extension assembly with a soft hammer (A).

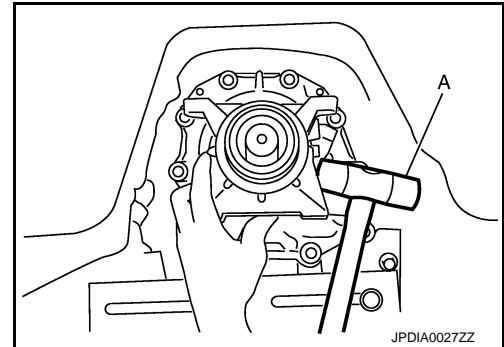

10. Remove rear extension assembly (with needle bearing) from transmission case.

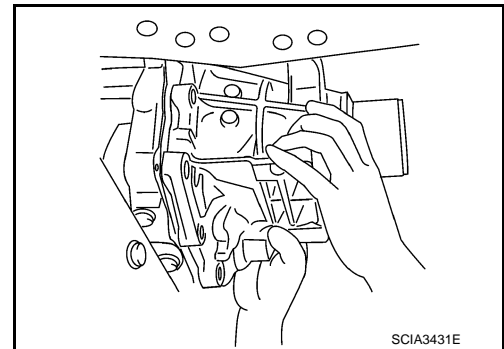

11. Remove bearing race (1) from output shaft (2).

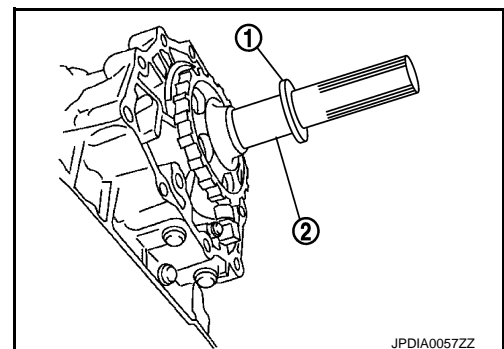

12. Remove output shaft (1) from transmission case by rotating left/right.

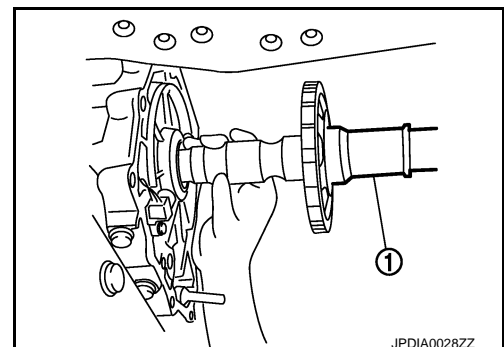

A
B
C
TM
E
F
G
H
I
J
K
L
M
N
O
P

PARKING COMPONENTS

< REMOVAL AND INSTALLATION >

[5AT: RE5R05A]

13. Remove parking gear (1) from output shaft (2).

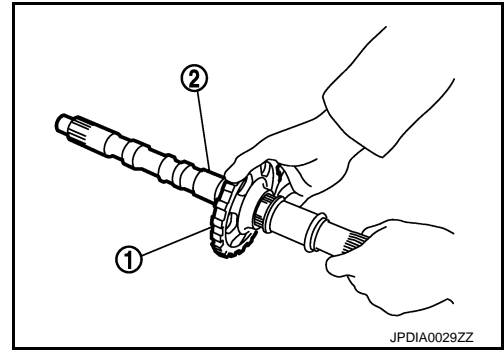

14. Remove seal rings (1) from output shaft.

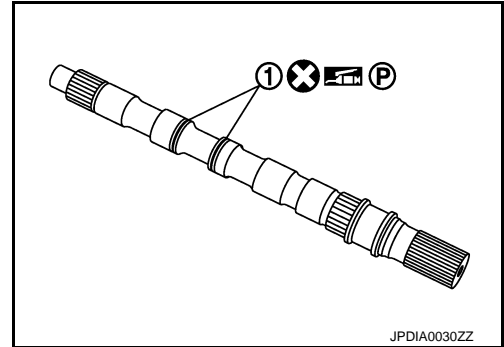

15. Remove needle bearing (1) from rear extension.

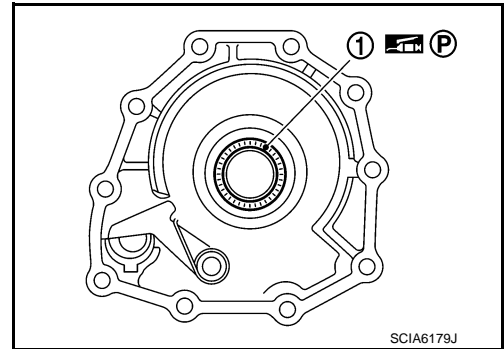

16. Remove parking actuator support (1) from rear extension.

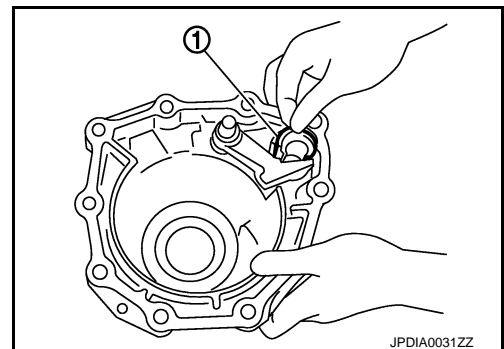

17. Remove parking pawl (with return spring) (1) and pawl shaft (2) from rear extension.

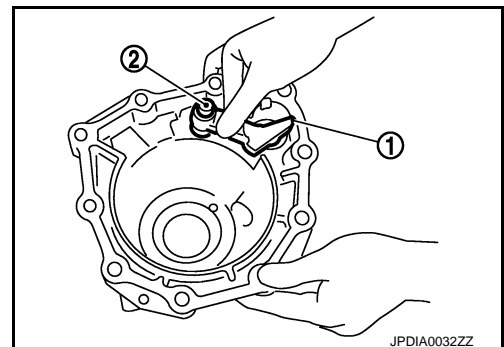

PARKING COMPONENTS

< REMOVAL AND INSTALLATION >

[5AT: RE5R05A]

18. Remove return spring (1) from parking pawl (2).

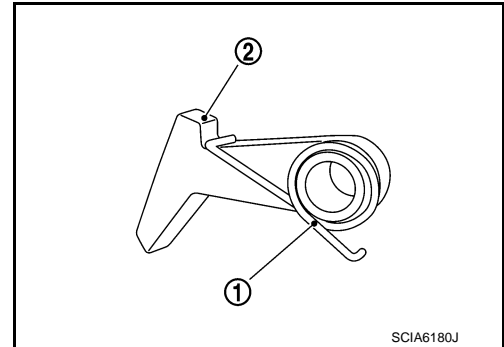

19. Remove rear oil seal (1) from rear extension with a flat-blade screwdriver (A).

CAUTION:

Be careful not to scratch rear extension.

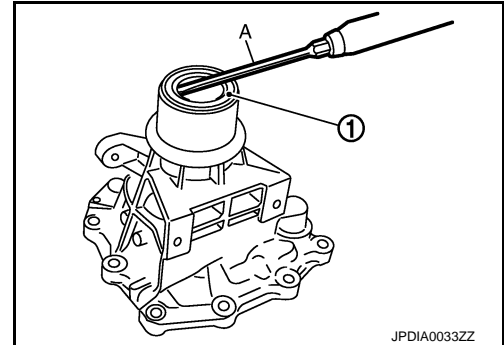

INSTALLATION

Note the following, and install in the reverse order of removal.

CAUTION:

- Never reuse seal rings and drain plug gasket.
- Apply petroleum jelly to needle bearing and seal rings.
- Insert the tip of parking rod between the parking pawl and the parking actuator support when assembling the rear extension assembly.
- As shown in the figure, use a drift [SST: ST33400001 (J-26082)] (A) to drive rear oil seal into the rear extension until it is flush.

CAUTION:

- Never reuse rear oil seal.
- Apply ATF to rear oil seal.

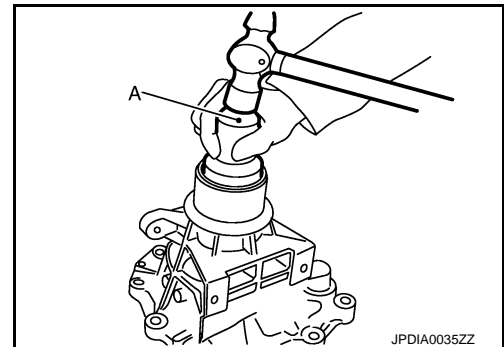

- Refer to the followings installing rear extension assembly.

A
B
C
TM
E
F
G
H
I
J
K
L
M
N
O
P

PARKING COMPONENTS

< REMOVAL AND INSTALLATION >

[5AT: RE5R05A]

- Apply recommended sealant (Genuine Anaerobic Liquid Gasket or equivalent. Refer to [GI-17, "Recommended Chemical Products and Sealants"](#).) to rear extension assembly as shown in the figure.

- A** : Start and finish point shall be in the center of two bolts.
- B** : 3 – 5 mm (0.12 – 0.20 in)
- Sealant width (C)** : 1.0 – 2.0 mm (0.04 – 0.08 in)
- Sealant height (C)** : 0.4 – 1.0 mm (0.016 – 0.04 in)

CAUTION:

Completely remove all moisture, oil and old sealant, etc. from the transmission case and rear extension assembly mounting surfaces.

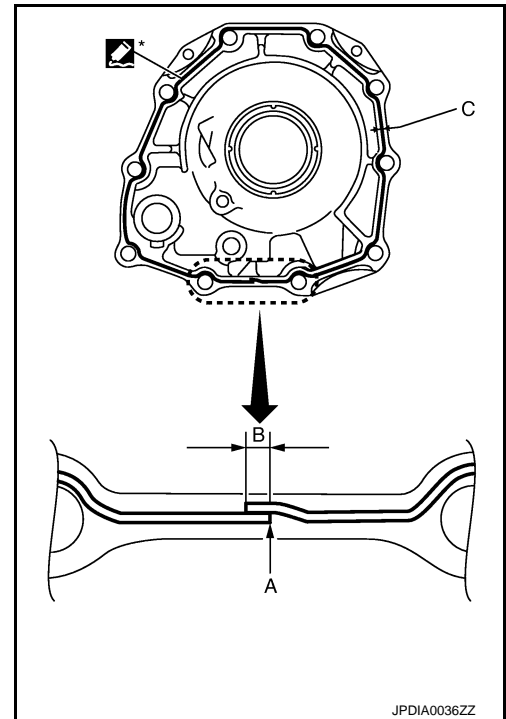

- Tighten rear extension assembly bolts to the specified torque.

- 1 : Self-sealing bolt
- A : Bolt

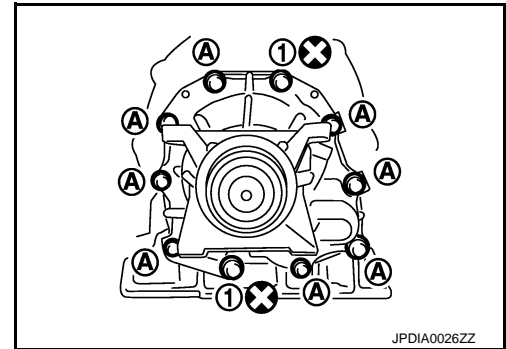

2WD : Inspection

INFOID:000000004343024

INSPECTION AFTER REMOVAL

PARKING COMPONENTS

< REMOVAL AND INSTALLATION >

[5AT: RE5R05A]

If the contact surface on parking actuator support (1), parking pawl (2) and etc. has excessive wear, abrasion, bend, or any other damage, replace the components.

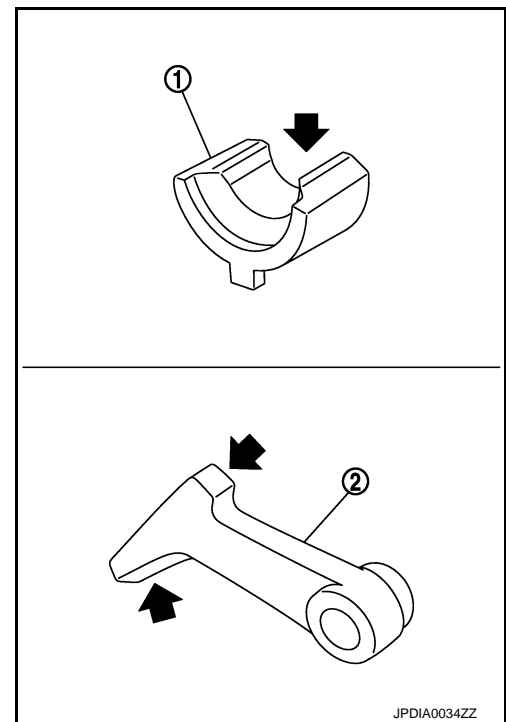

ADJUSTMENT AFTER INSTALLATION

Adjust A/T fluid level. Refer to [TM-143. "Adjustment"](#).

INSPECTION AFTER INSTALLATION

Check the following items.

- A/T fluid leakage.
- A/T position. Refer to [TM-155. "2WD : Inspection and Adjustment"](#).

A
B
C
TM
E
F
G
H
I
J
K
L
M
N
O
P

REAR OIL SEAL

< REMOVAL AND INSTALLATION >

[5AT: RE5R05A]

REAR OIL SEAL

2WD

2WD : Exploded View

INFOID:000000004343025

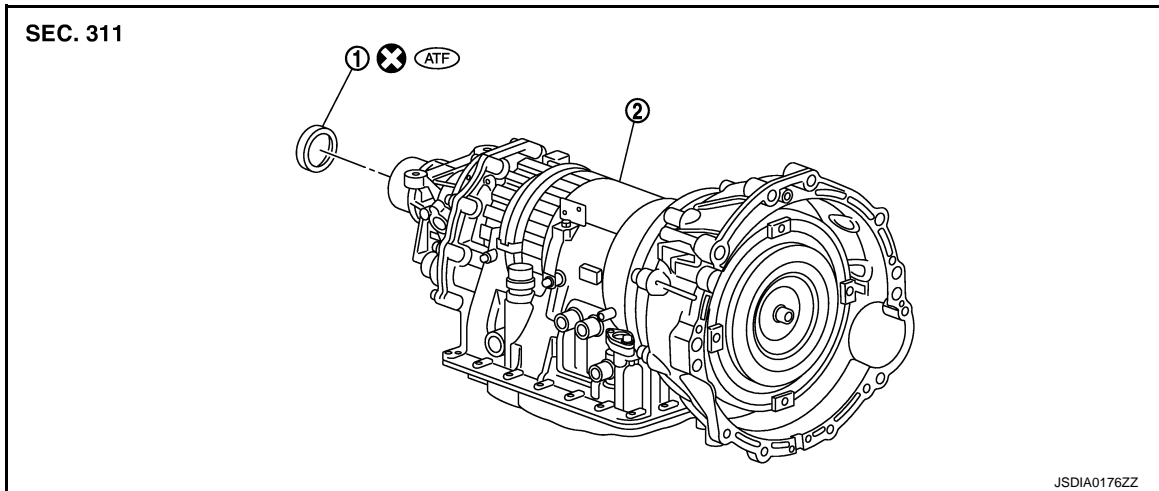

1. Rear oil seal
 2. A/T
- Refer to [GI-4, "Components"](#) for symbols in the figure.

2WD : Removal and Installation

INFOID:000000004343026

REMOVAL

1. Remove exhaust front tube and center muffler with power tool. Refer to [EX-5, "Exploded View"](#).
2. Remove rear propeller shaft. Refer to [DLN-82, "Exploded View"](#).
3. Remove rear oil seal (1) with a flat-bladed screwdriver (A).

CAUTION:
Be careful not to scratch rear extension assembly.

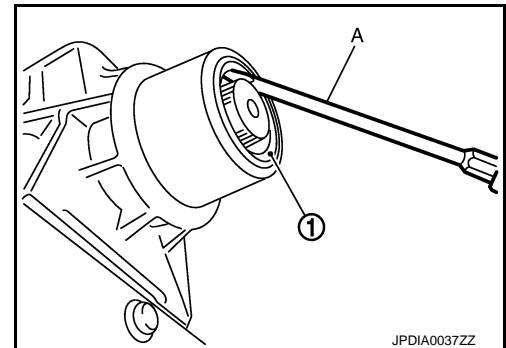

INSTALLATION

Note the following, and install in the reverse order of removal.

- As shown in the figure, use the drift [SST: ST33400001 (J-26082)] (A) to drive rear oil seal into rear extension assembly until it is flush.

- CAUTION:**
- Never reuse rear oil seal.
 - Apply ATF to rear oil seal.

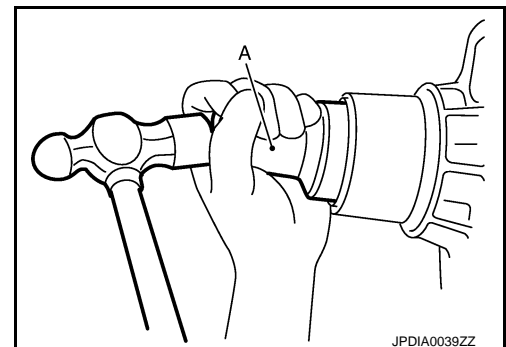

REAR OIL SEAL

< REMOVAL AND INSTALLATION >

[5AT: RE5R05A]

2WD : Inspection and Adjustment

INFOID:000000004343027

ADJUSTMENT AFTER INSTALLATION

Adjust A/T fluid level. Refer to [TM-143](#), "Adjustment".

INSPECTION AFTER INSTALLATION

Check A/T fluid leakage.

AWD

AWD : Exploded View

INFOID:000000004343028

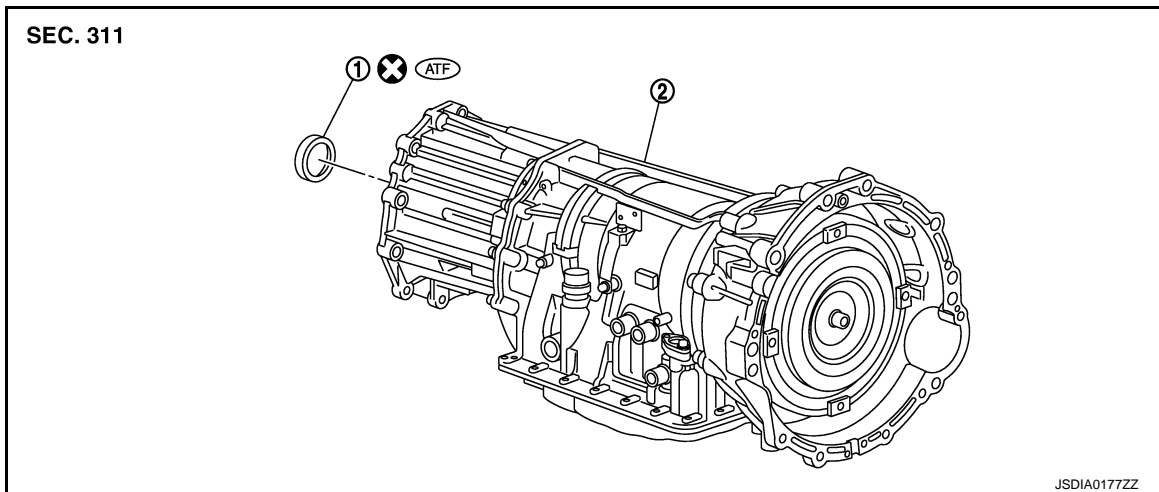

1. Rear oil seal
 2. A/T
- Refer to [GI-4](#), "Components" for symbols in the figure.

AWD : Removal and Installation

INFOID:000000004343029

REMOVAL

1. Remove exhaust front tube and center muffler with power tool. Refer to [EX-5](#), "Exploded View".
2. Remove rear propeller shaft. Refer to [DLN-91](#), "Exploded View".
3. Remove exhaust mounting bracket. Refer to [EX-5](#), "Exploded View".
4. Remove three way catalyst (right bank). Refer to [EX-5](#), "Exploded View".
5. Remove front propeller shaft. Refer to [DLN-76](#), "Exploded View".
6. Remove transfer assembly from A/T assembly. Refer to [DLN-51](#), "Exploded View".
7. Remove rear oil seal (1) with a flat-bladed screwdriver (A).

CAUTION:

Be careful not to scratch adapter case assembly.

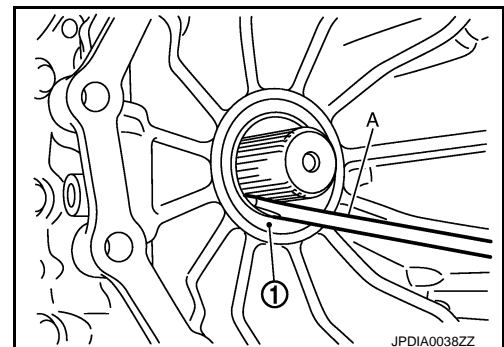

INSTALLATION

Note the following, and install in the reverse order of removal.

REAR OIL SEAL

< REMOVAL AND INSTALLATION >

[5AT: RE5R05A]

- As shown in the figure, use the drift [64 mm (2.52 in) dia. commercial service tool] (A) to drive rear oil seal into adapter case assembly until it is flush.

CAUTION:

- **Never reuse rear oil seal.**
- **Apply ATF to rear oil seal.**

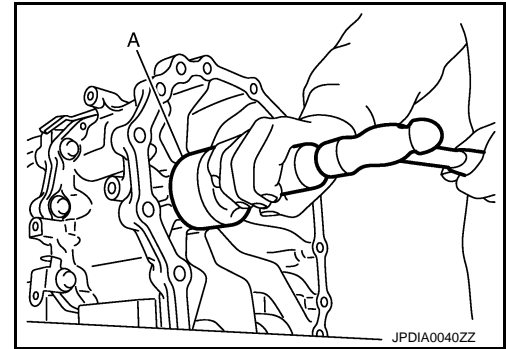

AWD : Inspection and Adjustment

INFOID:000000004343030

ADJUSTMENT AFTER INSTALLATION

Adjust A/T fluid level. Refer to [TM-143. "Adjustment"](#).

INSPECTION AFTER INSTALLATION

Check A/T fluid leakage.

OUTPUT SPEED SENSOR

< REMOVAL AND INSTALLATION >

[5AT: RE5R05A]

OUTPUT SPEED SENSOR

2WD

2WD : Exploded View

INFOID:000000004343031

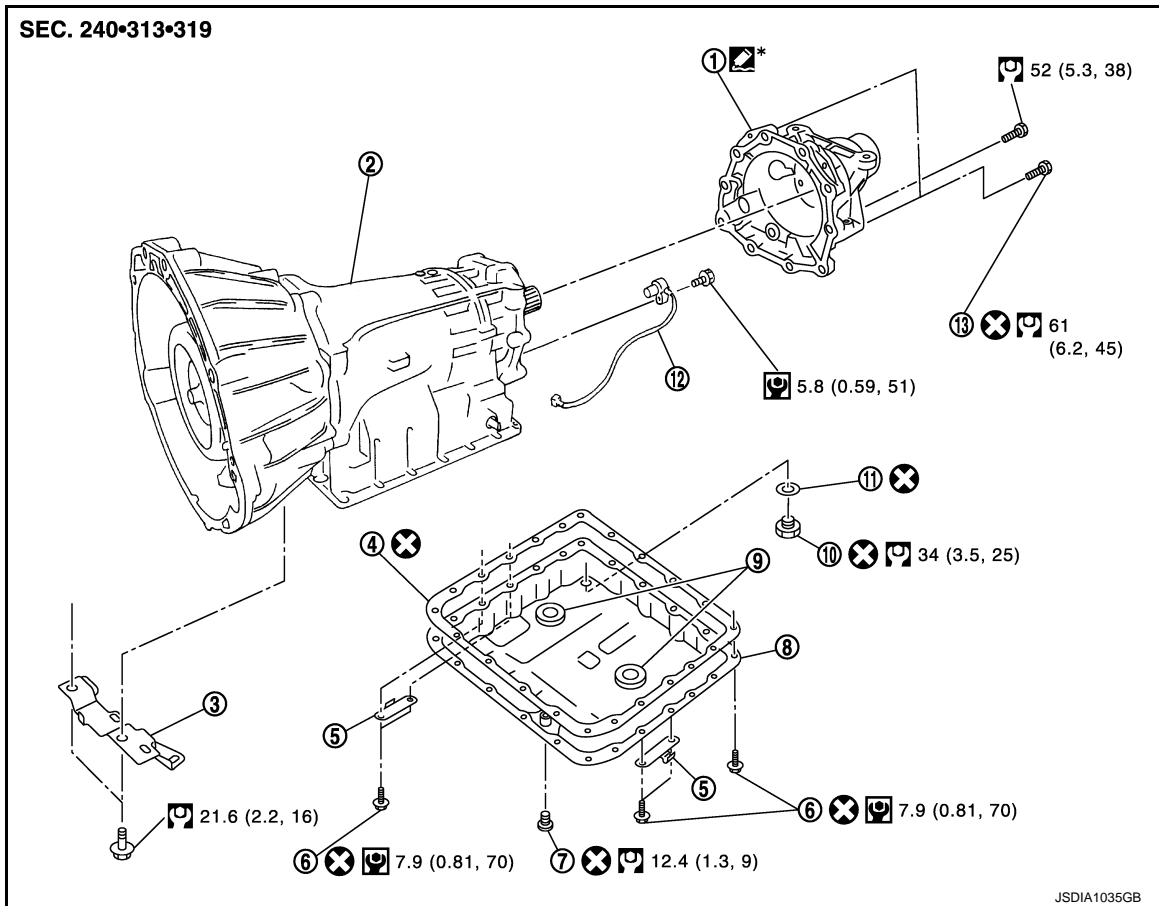

- | | | |
|-----------------------|-----------------------|--------------------------|
| 1. Rear extension | 2. A/T | 3. Bracket |
| 4. Oil pan gasket | 5. Clip | 6. Oil pan mounting bolt |
| 7. Overflow plug | 8. Oil pan | 9. Magnet |
| 10. Drain plug | 11. Drain plug gasket | 12. Output speed sensor |
| 13. Self-sealing bolt | | |

[Symbol]: Apply Genuine Anaerobic Liquid Gasket or equivalent. Refer to [GI-17, "Recommended Chemical Products and Sealants"](#).

Refer to [GI-4, "Components"](#) for symbols not described on the above.

2WD : Removal and Installation

INFOID:000000004343032

REMOVAL

1. Disconnect the battery cable from the negative terminal.
2. Drain ATF through drain plug.
3. Remove exhaust front tube and center muffler with power tool. Refer to [EX-5, "Exploded View"](#).
4. Remove rear propeller shaft. Refer to [DLN-82, "Exploded View"](#).
5. Remove control rod. Refer to [TM-163, "Exploded View"](#).
6. Remove exhaust mounting bracket. Refer to [EX-5, "Exploded View"](#).

OUTPUT SPEED SENSOR

< REMOVAL AND INSTALLATION >

[5AT: RE5R05A]

7. Disconnect heated oxygen sensor 2 connectors (A).

⇐ : Vehicle front

← : Bolt

8. Remove heated oxygen sensor 2 harness (B) from clips (1).
9. Remove bracket (2) from transmission assembly.

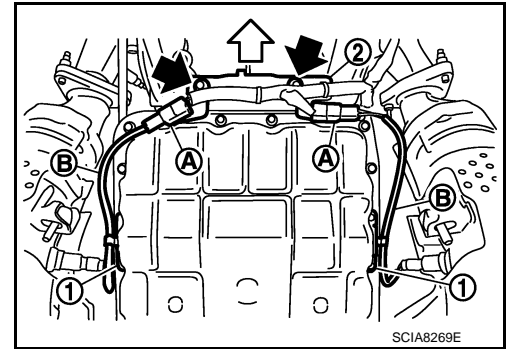

10. Remove clips (1).
11. Remove oil pan (2) and oil pan gasket.

⇐ : Vehicle front

← : Oil pan mounting bolt

12. Support A/T assembly with a transmission jack.

CAUTION:

When setting transmission jack, place wooden blocks to prevent from damaging control valve with TCM and transmission case.

13. Remove rear engine mounting member with power tool. Refer to [EM-79. "2WD : Exploded View"](#).
14. Remove engine mounting insulator (rear). Refer to [EM-79. "2WD : Exploded View"](#).
15. Remove tightening bolts for rear extension assembly and transmission case.

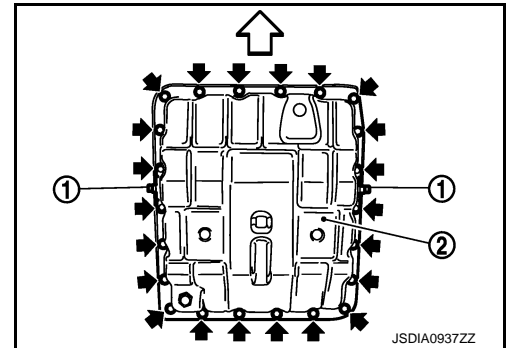

1 : Self-sealing bolt

A : Bolt

16. Tap rear extension assembly with a soft hammer (A).

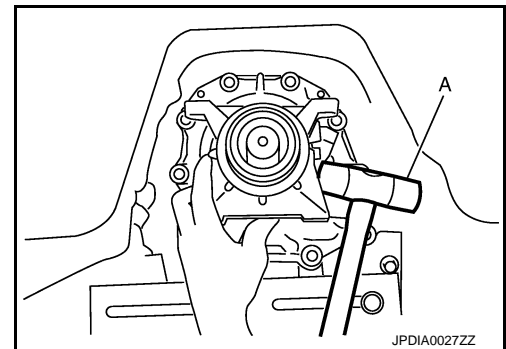
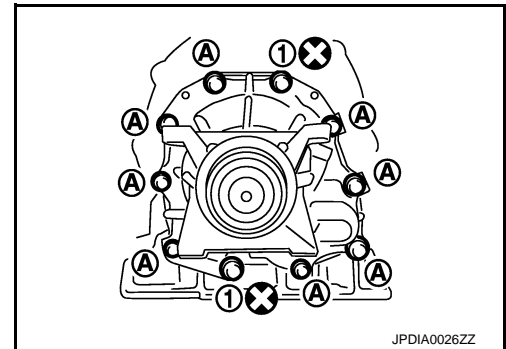

OUTPUT SPEED SENSOR

< REMOVAL AND INSTALLATION >

[5AT: RE5R05A]

17. Remove rear extension assembly (with needle bearing) from transmission case.

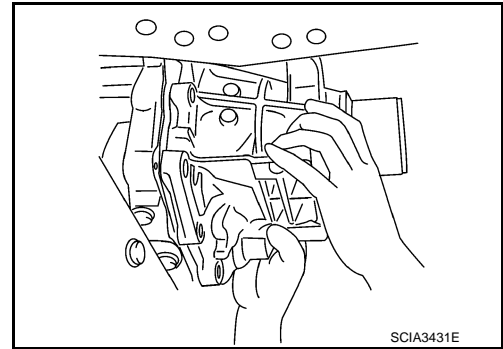

18. Disconnect output speed sensor connector (A).

CAUTION:

Be careful not to damage connector

19. Disengage terminal clip (←).

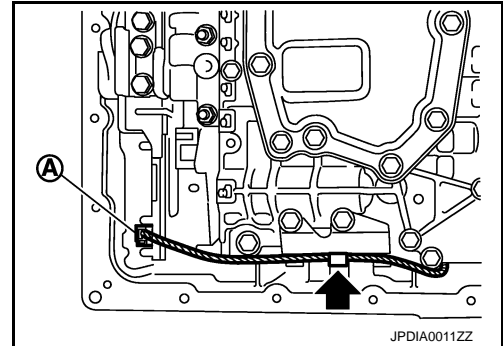

20. Remove output speed sensor (1) from transmission case.

← : Bolt

CAUTION:

- Never subject it to impact by dropping or hitting it.
- Never disassemble.
- Never allow metal filings, etc. to get on the sensor's front edge magnetic area.
- Never place in an area affected by magnetism.

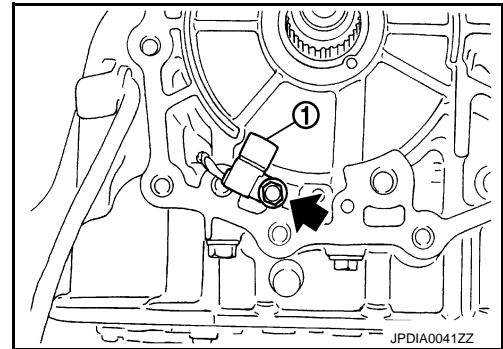

INSTALLATION

Note the following, and install in the reverse order removal.

CAUTION:

- Insert the tip of parking rod between the parking pole and the parking actuator support when assembling the rear extension assembly.
- Never reuse drain plug gasket.
- Refer to the followings when installing output speed sensor.

CAUTION:

- Never subject it to impact by dropping or hitting it.
- Never disassemble.
- Never allow metal filings, etc. to get on the sensor's front edge magnetic area.
- Never place in an area affected by magnetism.
- Refer to the followings when installing rear extension assembly.

A
B
C
TM
E
F
G
H
I
J
K
L
M
N
O
P

OUTPUT SPEED SENSOR

[5AT: RE5R05A]

< REMOVAL AND INSTALLATION >

- Apply recommended sealant (Genuine Anaerobic Liquid Gasket or equivalent. Refer to [GI-17, "Recommended Chemical Products and Sealants."](#)) to rear extension assembly as shown in the figure.

- A** : Start and finish point shall be in the center of two bolts.
- B** : 3 – 5 mm (0.12 – 0.20 in)
- Sealant width (C)** : 1.0 – 2.0 mm (0.04 – 0.08 in)
- Sealant height (C)** : 0.4 – 1.0 mm (0.016 – 0.04 in)

CAUTION:

Completely remove all moisture, oil and old sealant, etc. from transmission case and rear extension assembly mounting surfaces.

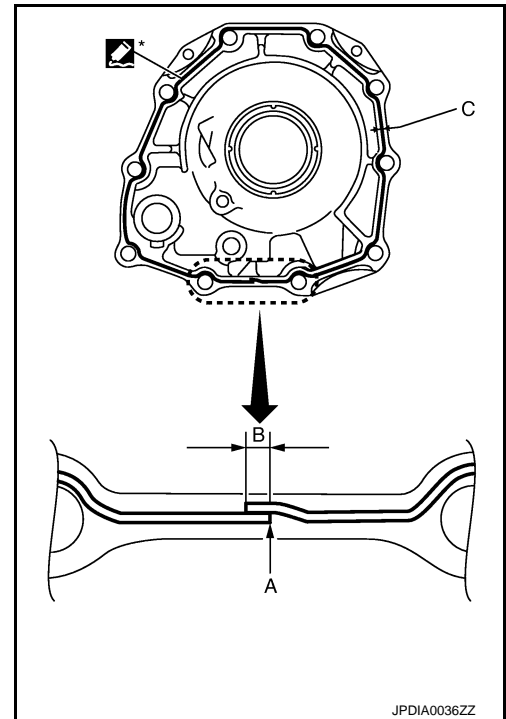

JPDIA0036ZZ

- Tighten rear extension assembly bolts to the specified torque.

- 1 : Self-searing bolt
A : Bolt

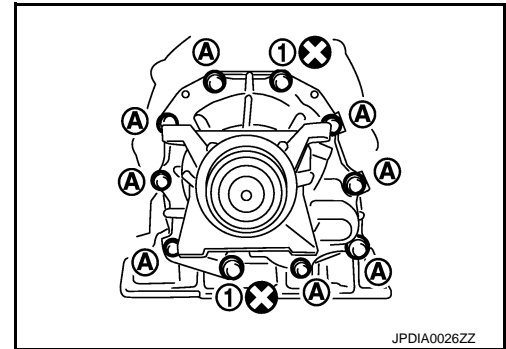

JPDIA0026ZZ

- Refer to the followings when installing oil pan (2) (with oil pan gasket) and clips (1) to transmission case.

- ⇐ : Vehicle front
← : Oil pan mounting bolt

CAUTION:

- Never reuse oil pan gasket and oil pan mounting gasket.
- Install oil pan gasket in the direction to align hole position.
- Install it so that drain plug comes to the position as shown in the figure.
- Be careful not to pinch harnesses.
- Completely remove all moisture, oil and old gasket, etc. from oil pan mounting surface.

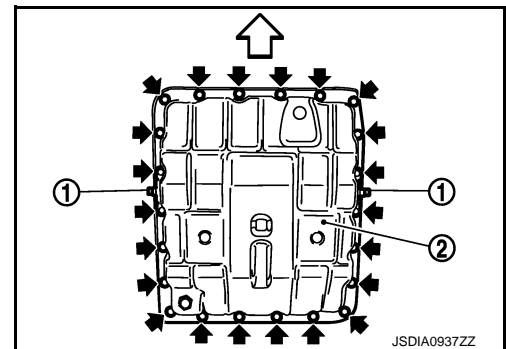

JSDIA0937ZZ

OUTPUT SPEED SENSOR

< REMOVAL AND INSTALLATION >

[5AT: RE5R05A]

- Tighten oil pan mounting bolts to the specified torque in numerical order shown in the figure after temporarily tightening them. Tighten necessary oil pan mounting bolts with specified torque.

← : Vehicle front

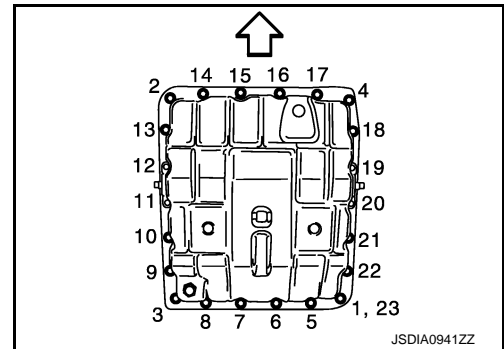

2WD : Inspection and Adjustment

INFOID:000000004343033

INSPECTION AFTER REMOVAL

Check foreign materials in oil pan to help determine causes of malfunction. If the ATF is very dark, smells burned, or contains foreign particles, the frictional material (clutches, band) may need replacement. A tacky film that will not wipe clean indicates varnish build up. Varnish can cause valves, servo, and clutches to stick and can inhibit pump pressure.

- If frictional material is detected, perform A/T fluid cooler cleaning. Refer to [TM-145, "Cleaning"](#).

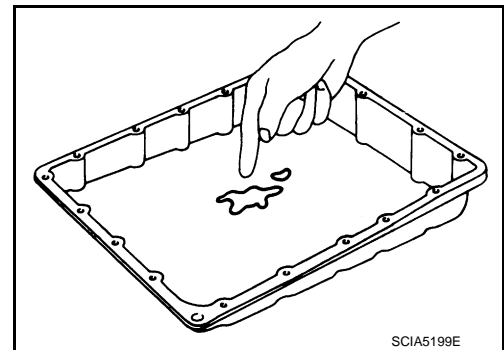

ADJUSTMENT AFTER INSTALLATION

Adjust A/T fluid level. Refer to [TM-143, "Adjustment"](#).

INSPECTION AFTER INSTALLATION

Check the following items.

- A/T fluid leakage.
- A/T position. Refer to [TM-155, "2WD : Inspection and Adjustment"](#).

AIR BREATHER HOSE

< REMOVAL AND INSTALLATION >

[5AT: RE5R05A]

AIR BREATHER HOSE

2WD

2WD : Exploded View

INFOID:000000004343034

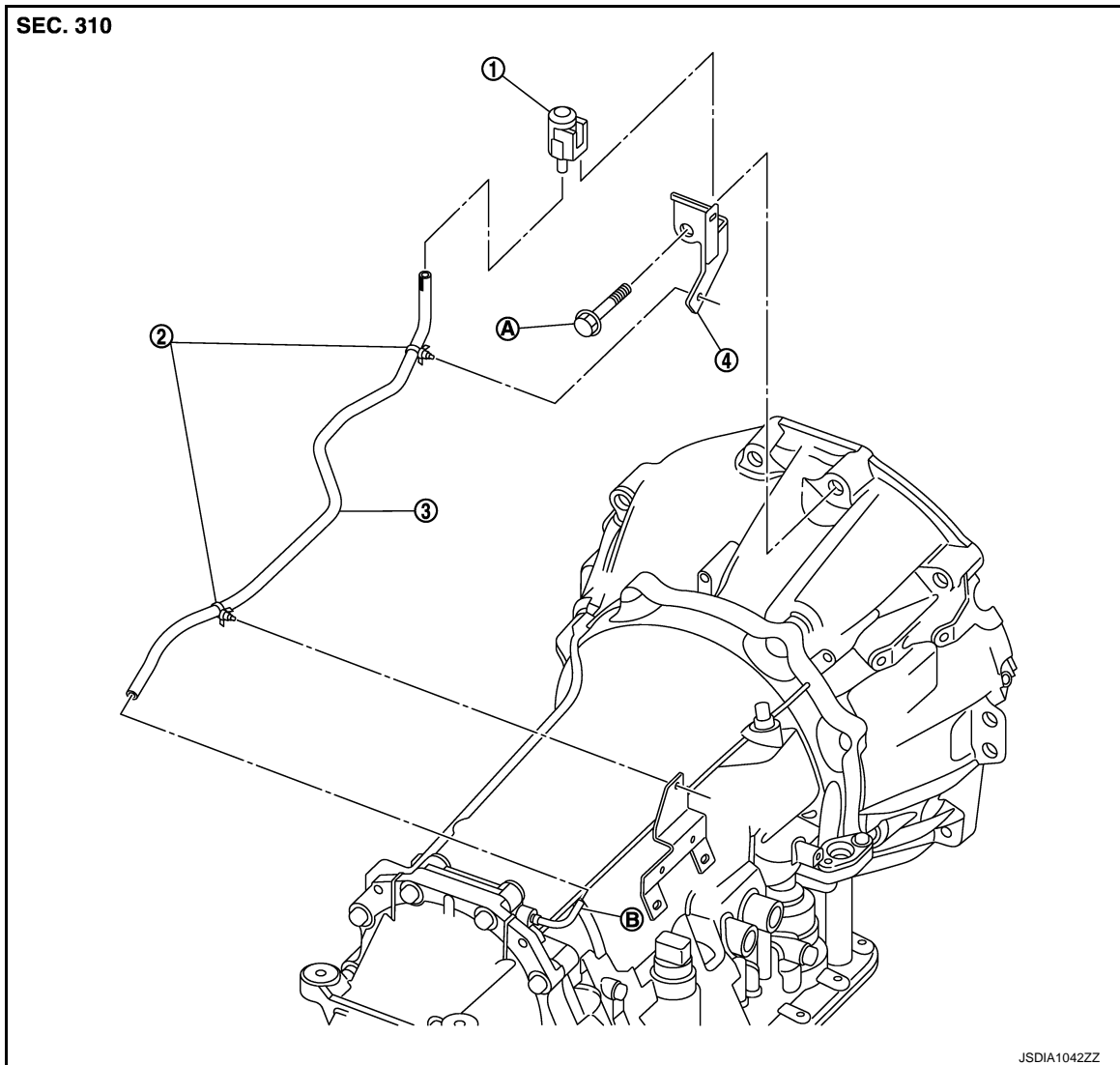

- | | | |
|---|---------|----------------------|
| 1. Air breather box | 2. Clip | 3. Air breather hose |
| 4. Bracket | | |
| A. For tightening torque, refer to TM-195, "2WD : Removal and Installation" . | | B. Air breather tube |

2WD : Removal and Installation

INFOID:000000004343035

REMOVAL

1. Remove air cleaner case (RH). Refer to [EM-27, "Exploded View"](#).
2. Remove exhaust front tube and center muffler with power tool. Refer to [EX-5, "Exploded View"](#).
3. Remove exhaust mounting bracket. Refer to [EX-5, "Exploded View"](#).
4. Remove three way catalyst (right bank). Refer to [EX-5, "Exploded View"](#).
5. Remove air breather hose.

INSTALLATION

Note the following, and install in the reverse order of removal.

CAUTION:

AIR BREATHER HOSE

< REMOVAL AND INSTALLATION >

[5AT: RE5R05A]

- When installing an air breather hose, be careful not to be crushed or blocked by folding or bending the hose.
- When inserting an air breather hose to the air breather tube, be sure to insert it fully until its end reaches the radius curve end.
- Ensure clips are securely installed to brackets when installing air breather hose to brackets.
- When inserting air breather hose to air breather box, be sure to insert it fully until its end reaches the stop.
- Install air breather hose to air breather box so that the paint mark is facing backward.

AWD

AWD : Exploded View

INFOID:000000004343036

A
B
C

TM

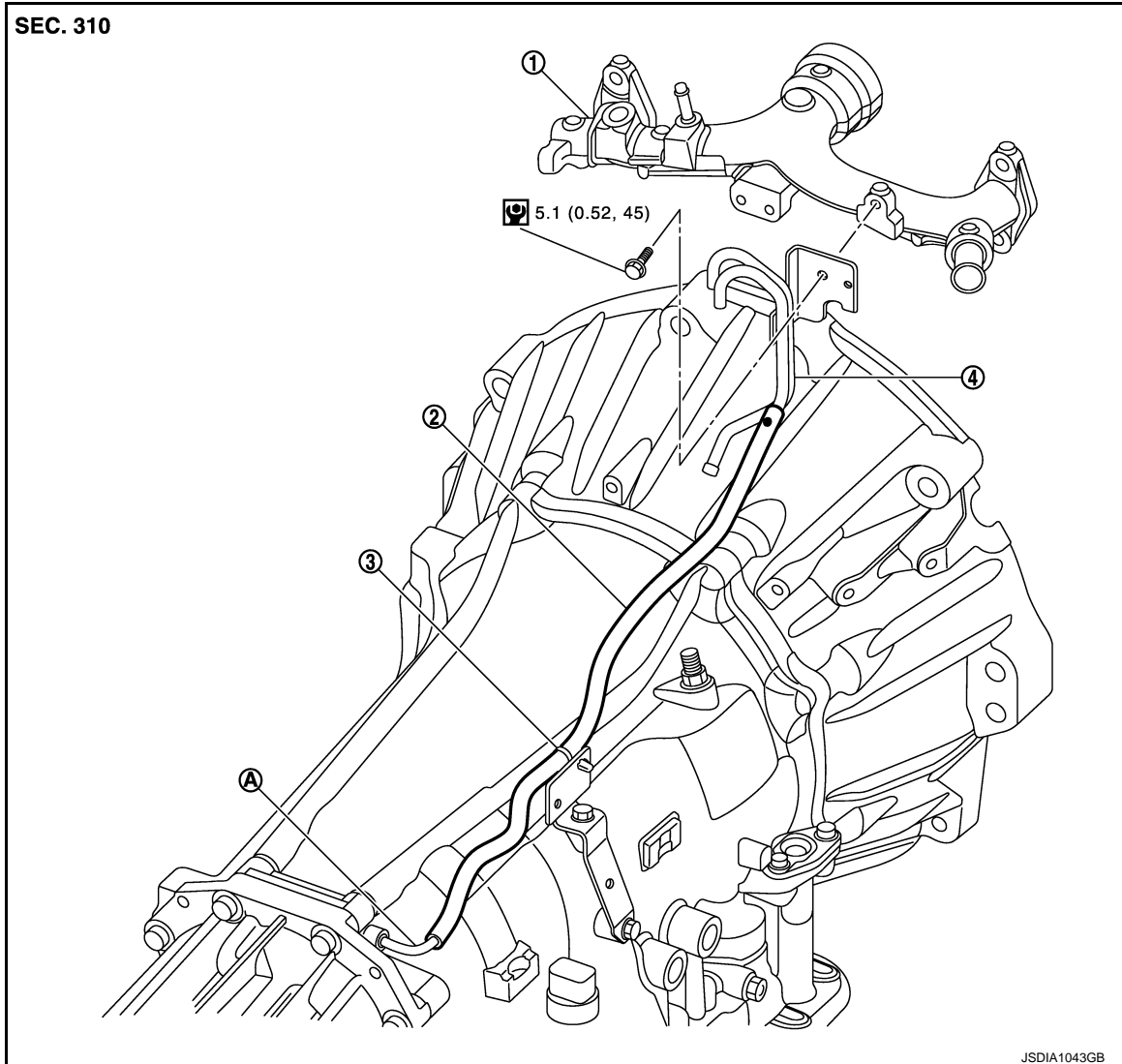

E
F
G
H
I
J
K
L
M
N
O
P

1. Water outlet (rear)
2. Air breather hose
3. Clip
4. Air breather vent
- A. Air breather tube

Refer to [GI-4, "Components"](#) for symbols in the figure.

AWD : Removal and Installation

INFOID:000000004343037

REMOVAL

1. Remove air cleaner case (RH). Refer to [EM-27, "Exploded View"](#).
2. Remove exhaust front tube and center muffler with power tool. Refer to [EX-5, "Exploded View"](#).

AIR BREATHER HOSE

< REMOVAL AND INSTALLATION >

[5AT: RE5R05A]

3. Remove exhaust mounting bracket. Refer to [EX-5, "Exploded View"](#).
4. Remove three way catalyst (right bank). Refer to [EX-5, "Exploded View"](#).
5. Remove air breather hose.

INSTALLATION

Note the following, and install in the reverse order of removal.

CAUTION:

- **When installing an air breather hose, be careful not to be crushed or blocked by folding or bending the hose.**
- **When inserting an air breather hose to the air breather tube, be sure to insert it fully until its end reaches the radius curve end.**
- **Ensure clip is securely installed to bracket when installing air breather hose to bracket.**
- **Install air breather hose to air breather vent so that the paint mark is facing upward.**

A/T FLUID COOLER TUBE

< REMOVAL AND INSTALLATION >

[5AT: RE5R05A]

A/T FLUID COOLER TUBE

2WD

2WD : Exploded View

INFOID:000000004343038

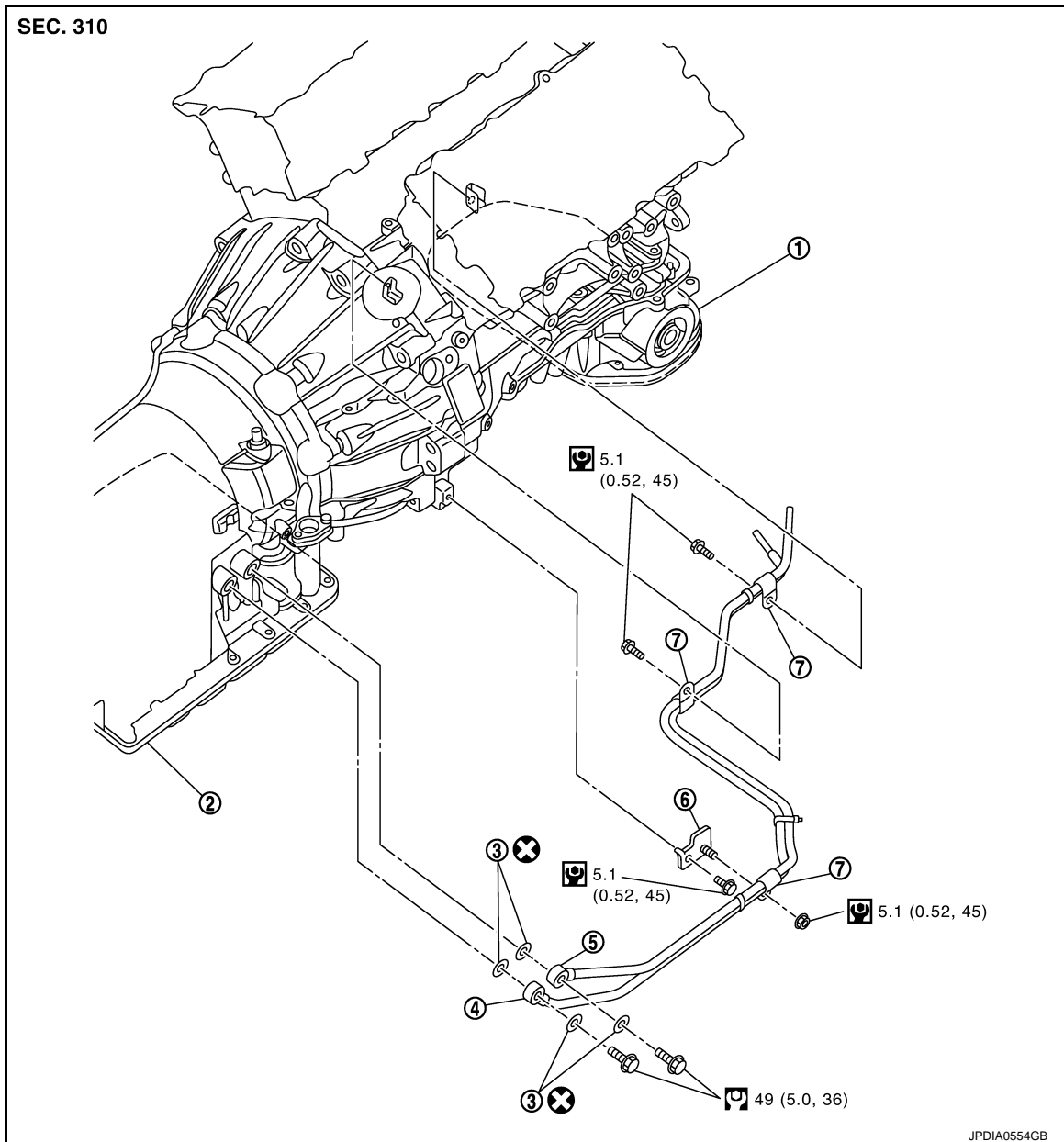

- | | | |
|--------------------------|--------------------------|------------------|
| 1. Engine assembly | 2. A/T assembly | 3. Copper washer |
| 4. A/T fluid cooler tube | 5. A/T fluid cooler tube | 6. Bracket |
| 7. Clip | | |

Refer to [GI-4, "Components"](#) for symbols in the figure.

2WD : Removal and Installation

INFOID:000000004343039

REMOVAL

1. Remove the engine lower cover with power tool. Refer to [EXT-31, "Exploded View"](#).
2. Remove the exhaust mounting bracket. Refer to [EX-5, "Exploded View"](#).
3. Remove the suspension member stay. Refer to [FSU-18, "Exploded View"](#).

A/T FLUID COOLER TUBE

[5AT: RE5R05A]

< REMOVAL AND INSTALLATION >

4. Pull out the A/T fluid cooler hose from the A/T fluid cooler tube. Refer to [CO-12, "Exploded View"](#)
5. Remove the A/T fluid cooler tube from the A/T assembly and engine assembly.
6. Remove the stabilizer bar. Refer to [FSU-17, "Exploded View"](#).
7. Loosen the lower mounting nuts for the engine mounting insulators (RH and LH). Refer to [EM-79, "2WD : Exploded View"](#).
8. Set a jack to the engine assembly and slightly lift the engine assembly.
CAUTION:
Never pull the harnesses, hoses, etc. excessively.
9. Remove the A/T fluid cooler tube from the vehicle.
CAUTION:
Be careful not to bend A/T fluid cooler tube.

INSTALLATION

Install in the reverse order of removal.

2WD : Inspection and Adjustment

INFOID:000000004343040

ADJUSTMENT AFTER INSTALLATION

Adjustment A/T fluid level. Refer to [TM-143, "Adjustment"](#).

INSPECTION AFTER INSTALLATION

Check A/T fluid leakage.

AWD

A/T FLUID COOLER TUBE

< REMOVAL AND INSTALLATION >

[5AT: RE5R05A]

AWD : Exploded View

INFOID:000000004343041

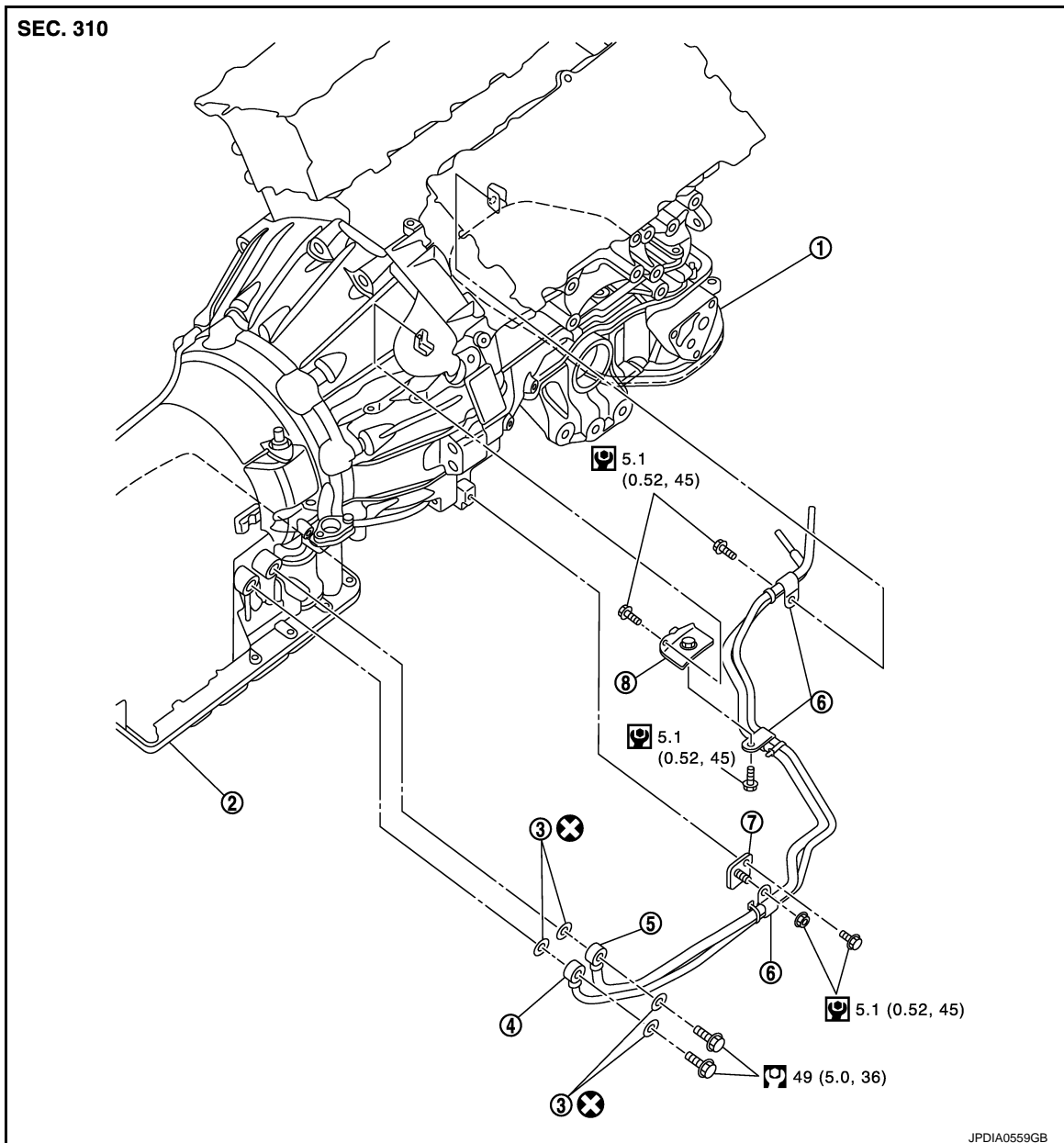

- | | | |
|--------------------------|--------------------------|------------------|
| 1. Engine assembly | 2. A/T assembly | 3. Copper washer |
| 4. A/T fluid cooler tube | 5. A/T fluid cooler tube | 6. Clip |
| 7. Bracket | 8. Bracket | |

Refer to [GI-4, "Components"](#) for symbols in the figure.

AWD : Removal and Installation

INFOID:000000004343042

REMOVAL

1. Remove the engine lower cover and front under cover with power tool. Refer to [EXT-31, "Exploded View"](#).
2. Remove the front suspension member. Refer to [FSU-37, "Exploded View"](#).
3. Remove exhaust front tube and center muffler with power tool. Refer to [EX-5, "Exploded View"](#).
4. Remove exhaust mounting bracket. Refer to [EX-5, "Exploded View"](#).
5. Remove the three way catalyst (right bank). Refer to [EX-5, "Exploded View"](#).
6. Remove front propeller shaft. Refer to [DLN-76, "Exploded View"](#).

A/T FLUID COOLER TUBE

[5AT: RE5R05A]

< REMOVAL AND INSTALLATION >

7. Pull out the A/T fluid cooler hose from the A/T fluid cooler tube. Refer to [CO-12. "Exploded View"](#).
8. Remove the A/T fluid cooler tube from the A/T assembly and engine assembly.

CAUTION:

Be careful not to bend A/T fluid cooler tube.

INSTALLATION

Install in the reverse order of removal.

AWD : Inspection and Adjustment

INFOID:000000004343043

ADJUSTMENT AFTER INSTALLATION

Adjustment A/T fluid level. Refer to [TM-143. "Adjustment"](#).

INSPECTION AFTER INSTALLATION

Check A/T fluid leakage.

TRANSMISSION ASSEMBLY

< UNIT REMOVAL AND INSTALLATION >

[5AT: RE5R05A]

UNIT REMOVAL AND INSTALLATION

TRANSMISSION ASSEMBLY

2WD

2WD : Exploded View

INFOID:000000004343044

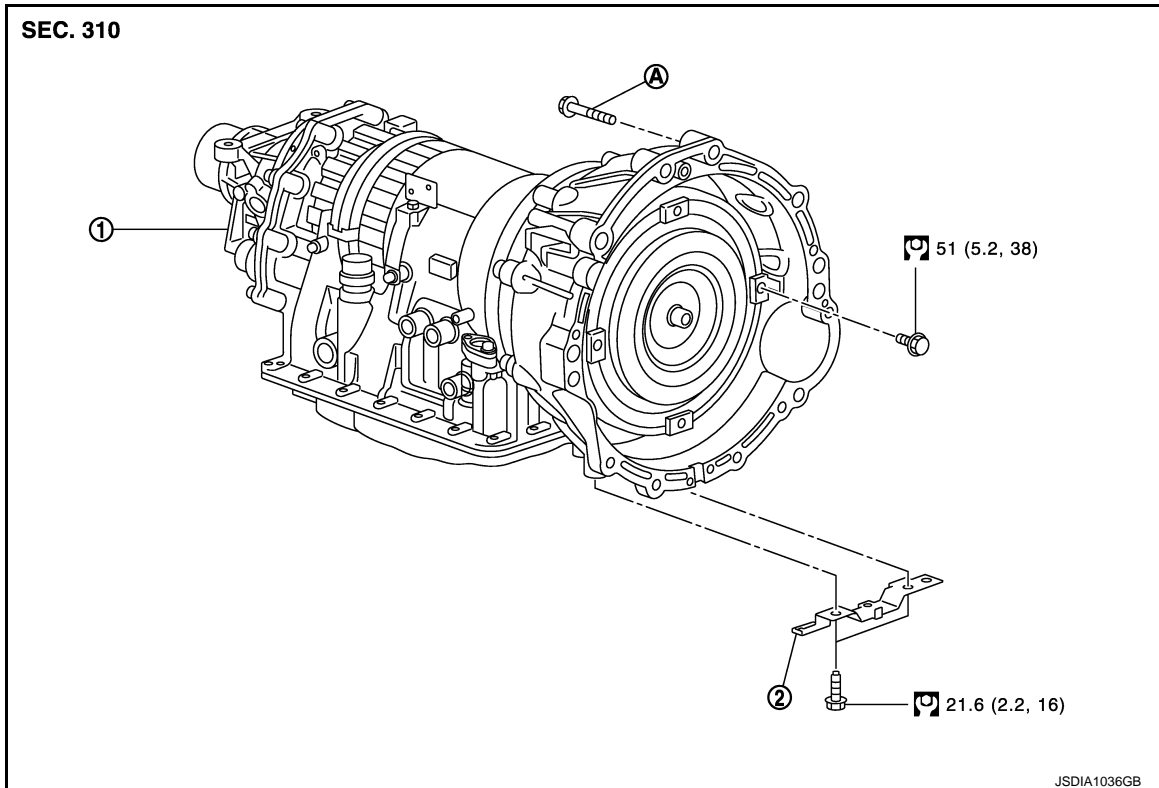

1. A/T assembly
 2. Bracket
- A. For tightening torque, refer to [TM-195, "2WD : Removal and Installation"](#).
Refer to [GI-4, "Components"](#) for symbols in the figure.

2WD : Removal and Installation

INFOID:000000004343045

REMOVAL

CAUTION:

- When removing the A/T assembly from engine, first remove the crankshaft position sensor (POS) from the A/T assembly.
- Be careful not to damage sensor edge.

1. Disconnect the battery cable from the negative terminal.
2. Remove air cleaner case (RH). Refer to [EM-27, "Exploded View"](#).
3. Remove engine lower cover with power tool. Refer to [EXT-31, "Exploded View"](#).
4. Remove exhaust front tube and center muffler with power tool. Refer to [EX-5, "Exploded View"](#).
5. Remove rear propeller shaft. Refer to [DLN-82, "Exploded View"](#).
6. Remove suspension member stay. Refer to [FSU-18, "Exploded View"](#).
7. Remove exhaust mounting bracket. Refer to [EX-5, "Exploded View"](#).

TRANSMISSION ASSEMBLY

< UNIT REMOVAL AND INSTALLATION >

[5AT: RE5R05A]

8. Disconnect heated oxygen sensor 2 connectors (A).

⇐ : Vehicle front

← : Bolt

9. Remove heated oxygen sensor 2 harness (B) from clips (1).
10. Remove bracket (2) from transmission assembly.
11. Remove control rod. Refer to [TM-163, "Exploded View"](#).
12. Remove crankshaft position sensor (POS) from A/T assembly. Refer to [EM-114, "Exploded View"](#).

CAUTION:

- Never subject it to impact by dropping or hitting it.
- Never disassemble.
- Never allow metal filings, etc. to get on the sensor's front edge magnetic area.
- Never place in an area affected by magnetism.

13. Remove starter motor. Refer to [STR-15, "Exploded View"](#).
14. Remove rear plate cover. Refer to [EM-43, "Exploded View \(2WD\)"](#).

15. Turn crankshaft, and remove the four tightening bolts for drive plate and torque converter.

CAUTION:

When turning the crankshaft, turn it clockwise as viewed from the front of the engine.

16. Support A/T assembly with a transmission jack.

CAUTION:

When setting the transmission jack, be careful not to allow it to collide against the drain plug.

17. Remove rear engine mounting member with power tool. Refer to [EM-79, "2WD : Exploded View"](#).

18. Remove engine mounting insulator (rear). Refer to [EM-79, "2WD : Exploded View"](#).

19. Disconnect A/T assembly connector and harness clips.

20. Remove air breather hose. Refer to [TM-188, "2WD : Exploded View"](#).

21. Disconnect fluid cooler tube from A/T assembly. Refer to [TM-191, "2WD : Exploded View"](#).

22. Remove bolts fixing A/T assembly to engine assembly with power tool.

23. Remove A/T assembly from vehicle.

CAUTION:

- Secure torque converter to prevent it from dropping.
- Secure A/T assembly to a transmission jack.

24. Remove dynamic damper. Refer to [EM-79, "2WD : Exploded View"](#).

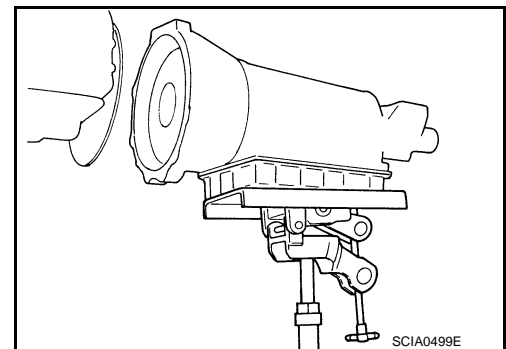
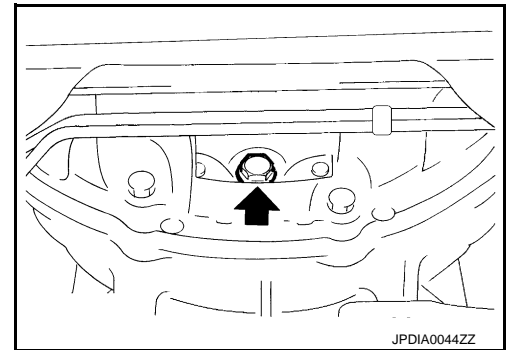
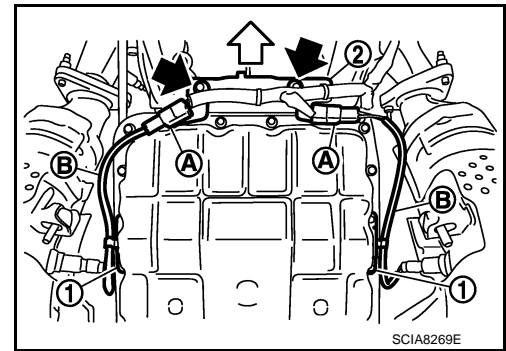

INSTALLATION

Note the following, and install in the reverse order of removal.

TRANSMISSION ASSEMBLY

< UNIT REMOVAL AND INSTALLATION >

[5AT: RE5R05A]

- When installing A/T assembly to the engine assembly, be sure to check dimension (A) to ensure it is within the reference value limit.

B : Scale
C : Straightedge

Dimension (A) : Refer to [TM-273, "Torque Converter"](#)

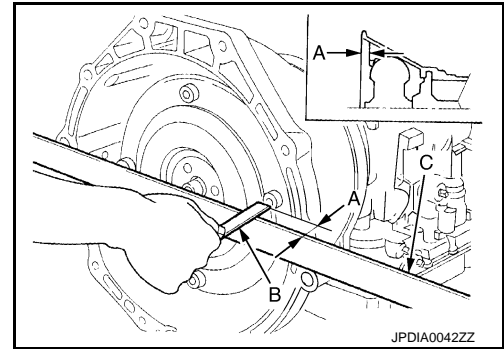

- When installing A/T assembly to the engine assembly, attach the fixing bolts in accordance with the following standard.

A : View from vehicle front
 ● : Transmission to engine
 ⊗ : Engine to transmission

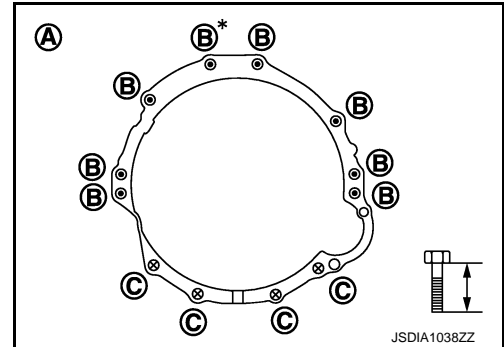

Bolt symbol	B	C
Number of bolts	8	4
Bolt length mm (in)	65 (2.56)	35 (1.38)
Tightening torque N·m (kg·m, ft·lb)	75 (7.7, 55)	46.6 (4.8, 34)

*: Tightening the bolt with bracket.

- Align the positions of tightening bolts for drive plate with those of the torque converter, and temporarily tighten the bolts. Then, tighten the bolts with the specified torque.

CAUTION:

- When turning crankshaft, turn it clockwise as viewed from the front of the engine.
- When tightening the tightening bolts for the torque converter after fixing the crankshaft pulley bolts, be sure to confirm the tightening torque of the crankshaft pulley mounting bolts. Refer to [EM-50, "Exploded View"](#).
- Rotate crankshaft several turns and check to be sure that A/T rotates freely without binding after converter is installed to drive plate.
- Install crankshaft position sensor (POS). Refer to [EM-114, "Exploded View"](#).

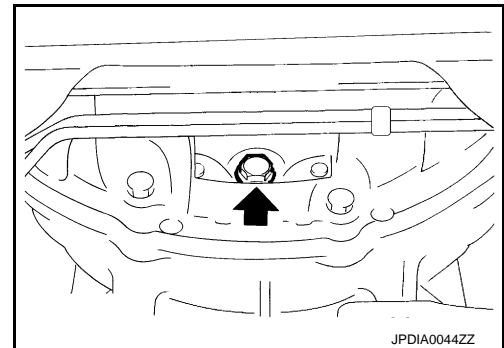

2WD : Inspection and Adjustment

INFOID:000000004343046

ADJUSTMENT AFTER INSTALLATION

Adjust A/T fluid level. Refer to [TM-143, "Adjustment"](#).

INSPECTION AFTER INSTALLATION

Check the following.

- A/T fluid leakage.
- A/T position. Refer to [TM-155, "2WD : Inspection and Adjustment"](#).

AWD

TRANSMISSION ASSEMBLY

< UNIT REMOVAL AND INSTALLATION >

[5AT: RE5R05A]

AWD : Exploded View

INFOID:000000004343047

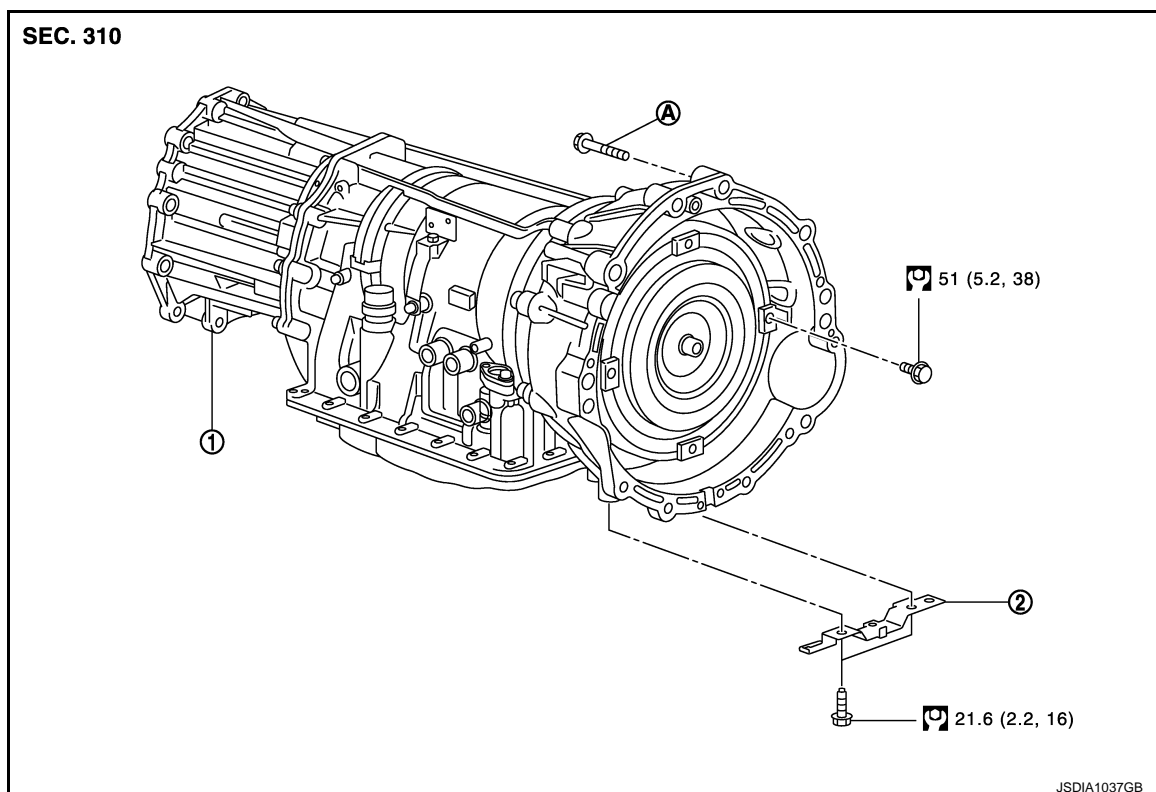

1. A/T assembly
2. Bracket

A. For tightening torque, Refer to [TM-195, "2WD : Removal and Installation"](#).

Refer to [GI-4, "Components"](#) for symbols in the figure.

AWD : Removal and Installation

INFOID:000000004343048

REMOVAL

CAUTION:

- When removing the A/T assembly from engine, first remove the crankshaft position sensor (POS) from the A/T assembly.

- Be careful not to damage sensor edge.

1. Disconnect the battery cable from the negative terminal.
2. Remove air cleaner case (RH). Refer to [EM-27, "Exploded View"](#).
3. Remove engine lower cover and front under cover with power tool. Refer to [EXT-31, "Exploded View"](#).
4. Remove exhaust front tube and center muffler and with power tool. Refer to [EX-5, "Exploded View"](#).
5. Remove rear propeller shaft. Refer to [DLN-91, "Exploded View"](#).
6. Remove front cross bar with power tool. Refer to [FSU-37, "Exploded View"](#).
7. Remove exhaust mounting bracket. Refer to [EX-5, "Exploded View"](#).

TRANSMISSION ASSEMBLY

< UNIT REMOVAL AND INSTALLATION >

[5AT: RE5R05A]

8. Disconnect heated oxygen sensor 2 connectors (A).

↔ : Vehicle front

← : Bolt

9. Remove heated oxygen sensor 2 harness (B) from clips (1).

10. Remove bracket (2) from transmission assembly.

11. Remove three way catalyst (right bank). Refer to [EX-5](#), "[Exploded View](#)".

12. Remove front propeller shaft. Refer to [DLN-76](#), "[Exploded View](#)".

13. Remove control rod. Refer to [TM-163](#), "[Exploded View](#)".

14. Remove crankshaft position sensor (POS) from A/T assembly. Refer to [EM-114](#), "[Exploded View](#)".

CAUTION:

- Never subject it to impact by dropping or hitting it.
- Never disassemble.
- Never allow metal filings, etc. to get on the sensor's front edge magnetic area.
- Never place in an area affected by magnetism.

15. Remove starter motor. Refer to [STR-15](#), "[Exploded View](#)".

16. Remove rear plate cover. Refer to [EM-44](#), "[Exploded View \(AWD\)](#)".

17. Turn crankshaft, and remove the four tightening bolts for drive plate and torque converter.

CAUTION:

When turning the crankshaft, turn it clockwise as viewed from the front of the engine.

18. Support A/T assembly with a transmission jack.

CAUTION:

When setting the transmission jack, be careful not to allow it to collide against the drain plug.

19. Remove rear engine mounting member with power tool. Refer to [EM-83](#), "[AWD : Exploded View](#)".

20. Remove engine mounting insulator (rear). Refer to [EM-83](#), "[AWD : Exploded View](#)".

21. Remove dynamic damper. Refer to [EM-83](#), "[AWD : Exploded View](#)".

22. Disconnect A/T assembly connector and harness clips.

23. Remove air breather hose. Refer to [TM-189](#), "[AWD : Exploded View](#)".

24. Disconnect fluid cooler tube from the A/T assembly. Refer to [TM-193](#), "[AWD : Exploded View](#)".

25. Remove bolts fixing A/T assembly to engine assembly with power tool.

26. Remove A/T assembly with transfer assembly from vehicle.

CAUTION:

- Secure torque converter to prevent it from dropping.
- Secure A/T assembly to a transmission jack.

27. Remove transfer assembly from A/T assembly with power tool. Refer to [DLN-51](#), "[Exploded View](#)".

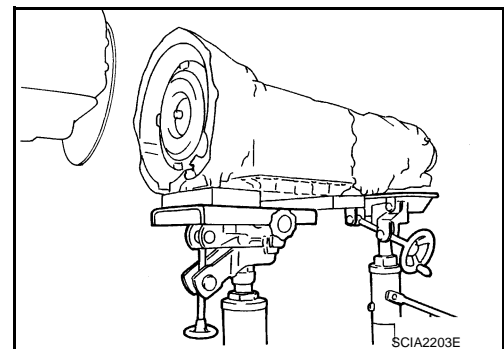
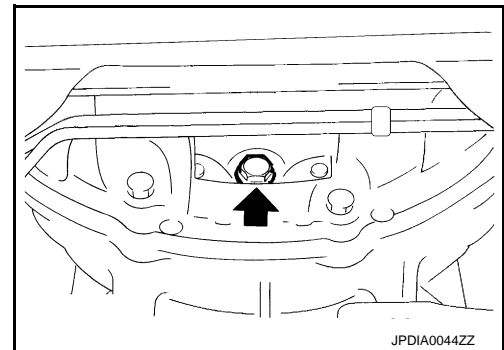
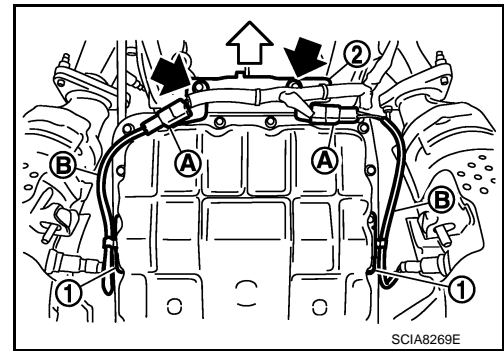

INSTALLATION

Note the following, and Install in the reverse order of removal.

TRANSMISSION ASSEMBLY

< UNIT REMOVAL AND INSTALLATION >

[5AT: RE5R05A]



- When installing A/T assembly to the engine assembly, be sure to check dimension (A) to ensure it is within the reference value limit.

B : Scale
C : Straightedge

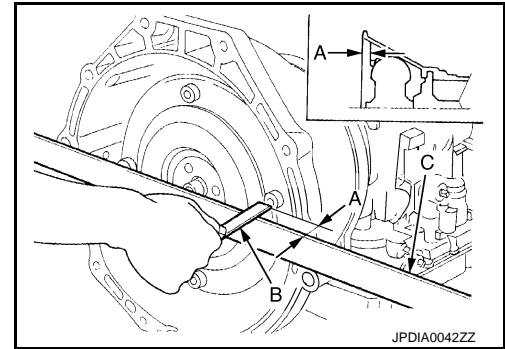
Dimension (A) : Refer to [TM-273, "Torque Converter"](#)



- When installing A/T assembly to the engine assembly, attach the fixing bolts in accordance with the following standard.

A : View from vehicle front
 : Transmission to engine
 : Engine to transmission

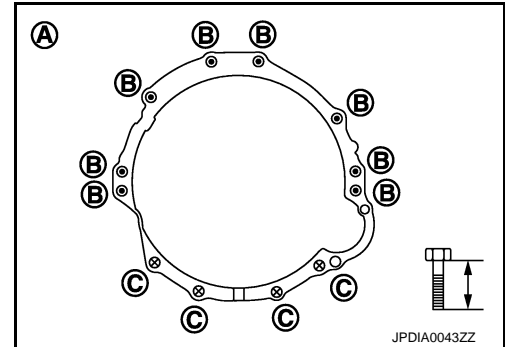

Bolt symbol	B	C
Number of bolts	8	4
Bolt length mm (in)	65 (2.56)	35 (1.38)
Tightening torque N·m (kg·m, ft·lb)	75 (7.7, 55)	46.6 (4.8, 34)

- Align the positions of tightening bolts for drive plate with those of the torque converter, and temporarily tighten the bolts. Then, tighten the bolts with the specified torque.

CAUTION:

- When turning crankshaft, turn it clockwise as viewed from the front of the engine.
- When tightening the tightening bolts for the torque converter after fixing the crankshaft pulley bolts, be sure to confirm the tightening torque of the crankshaft pulley mounting bolts. Refer to [EM-50, "Exploded View"](#).
- Rotate crankshaft several turns and check to be sure that A/T rotates freely without binding after converter is installed to drive plate.
- Install crankshaft position sensor (POS). Refer to [EM-114, "Exploded View"](#).

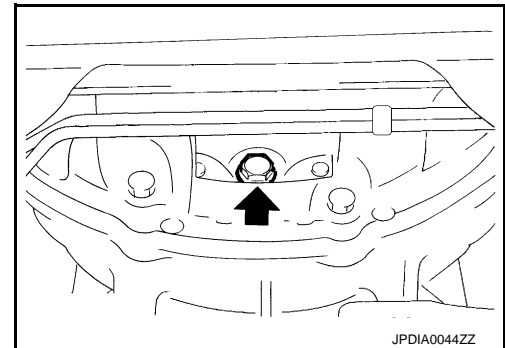

AWD : Inspection and Adjustment

INFOID:000000004343049

ADJUSTMENT AFTER INSTALLATION

Adjust A/T fluid level. Refer to [TM-143, "Adjustment"](#).

INSPECTION AFTER INSTALLATION

Check the following.

- A/T fluid leakage.
- A/T position. Refer to [TM-155, "AWD : Inspection and Adjustment"](#).

TRANSMISSION ASSEMBLY

< UNIT DISASSEMBLY AND ASSEMBLY >

[5AT: RE5R05A]

UNIT DISASSEMBLY AND ASSEMBLY

TRANSMISSION ASSEMBLY

Exploded View

INFOID:000000004343050

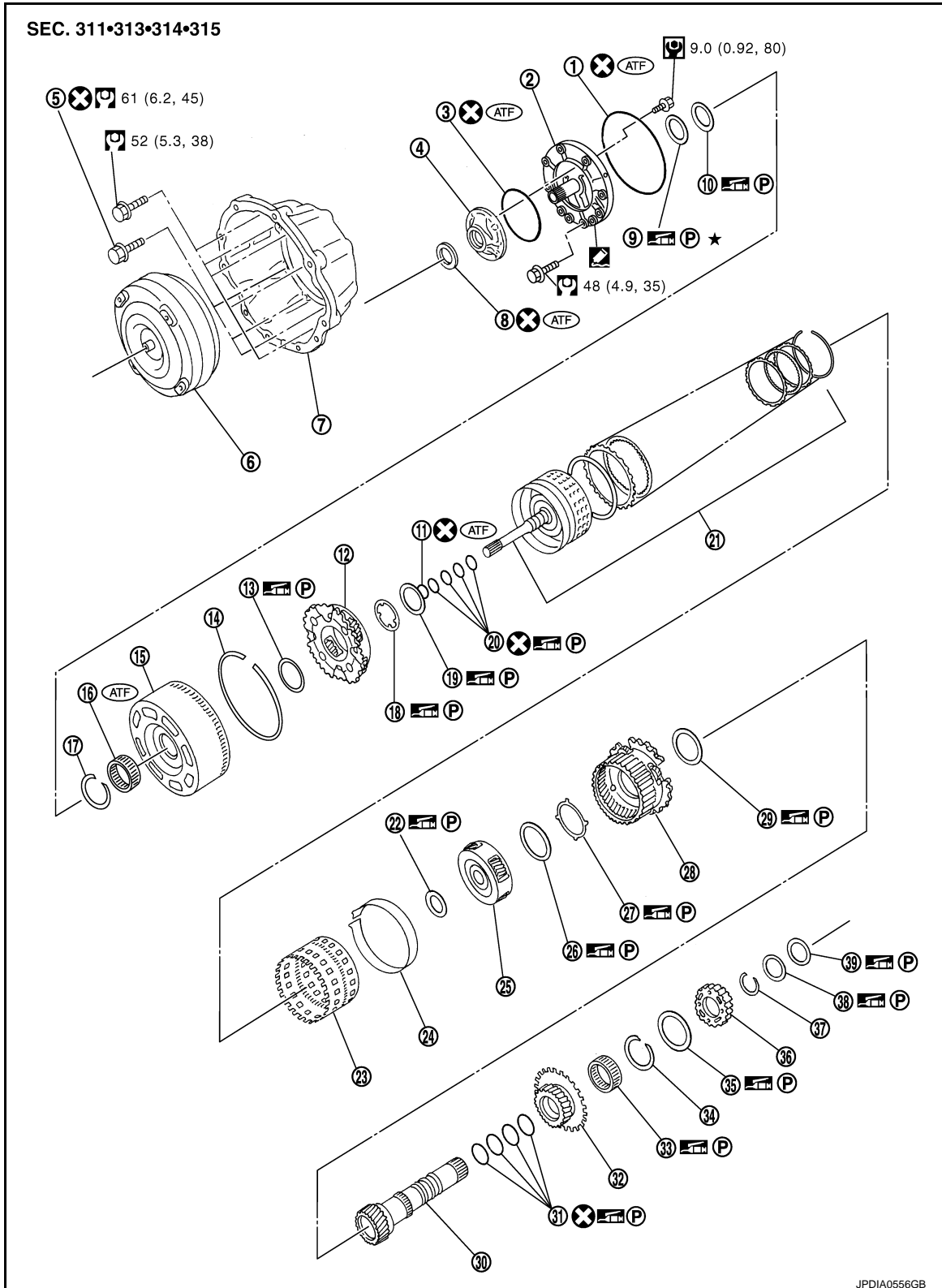

A
B
C
TM
E
F
G
H
I
J
K
L
M
N
O
P

TRANSMISSION ASSEMBLY

< UNIT DISASSEMBLY AND ASSEMBLY >

[5AT: RE5R05A]

- | | | |
|---------------------------|------------------------------|-------------------------------------|
| 1. O-ring | 2. Oil pump cover | 3. O-ring |
| 4. Oil pump housing | 5. Self-sealing bolt | 6. Torque converter |
| 7. Converter housing | 8. Oil pump housing oil seal | 9. Bearing race |
| 10. Needle bearing | 11. O-ring | 12. Front carrier assembly |
| 13. Needle bearing | 14. Snap ring | 15. Front sun gear |
| 16. 3rd one-way clutch | 17. Snap ring | 18. Bearing race |
| 19. Needle bearing | 20. Seal ring | 21. Input clutch assembly |
| 22. Needle bearing | 23. Rear internal gear | 24. Brake band |
| 25. Mid carrier assembly | 26. Needle bearing | 27. Bearing race |
| 28. Rear carrier assembly | 29. Needle bearing | 30. Mid sun gear |
| 31. Seal ring | 32. Rear sun gear | 33. 1st one-way clutch |
| 34. Snap ring | 35. Needle bearing | 36. High and low reverse clutch hub |
| 37. Snap ring | 38. Bearing race | 39. Needle bearing |

: Apply Genuine RTV silicone sealant or equivalent. Refer to [GI-17, "Recommended Chemical Products and Sealants"](#).

Refer to [GI-4, "Components"](#) for symbols not described on the above.

TRANSMISSION ASSEMBLY

< UNIT DISASSEMBLY AND ASSEMBLY >

[5AT: RE5R05A]

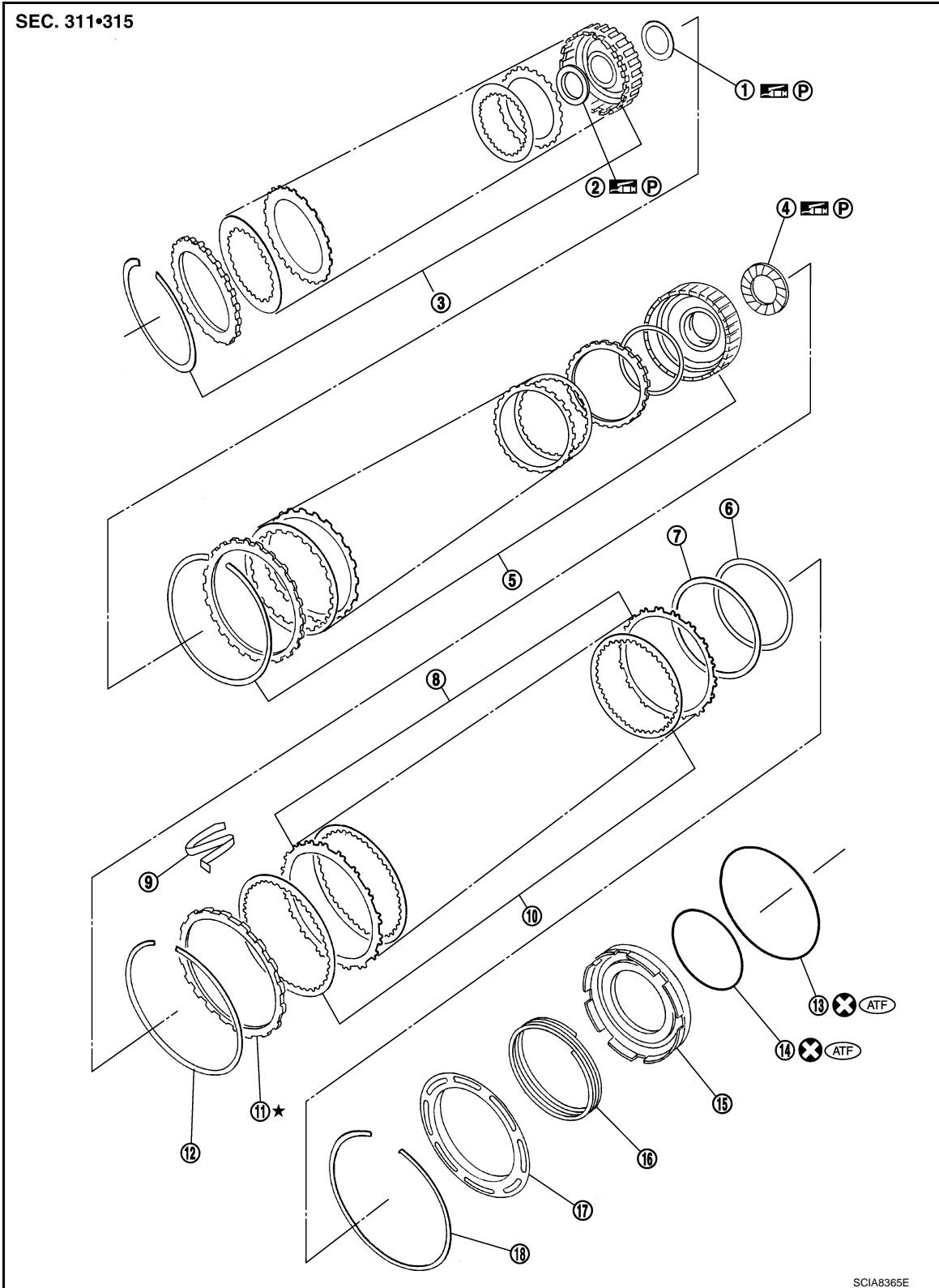

- | | | |
|-------------------------------|-----------------------------------|---|
| 1. Needle bearing | 2. Bearing race | 3. High and low reverse clutch assembly |
| 4. Needle bearing | 5. Direct clutch assembly | 6. Reverse brake dish plate |
| 7. Reverse brake dish plate | 8. Reverse brake driven plate | 9. N-spring |
| 10. Reverse brake drive plate | 11. Reverse brake retaining plate | 12. Snap ring |
| 13. D-ring | 14. D-ring | 15. Reverse brake piston |

A
B
C
TM
E
F
G
H
I
J
K
L
M
N
O
P

TRANSMISSION ASSEMBLY

< UNIT DISASSEMBLY AND ASSEMBLY >

[5AT: RE5R05A]

16. Return spring

17. Spring retainer

18. Snap ring

Refer to [GI-4, "Components"](#) for symbols in the figure.

2WD

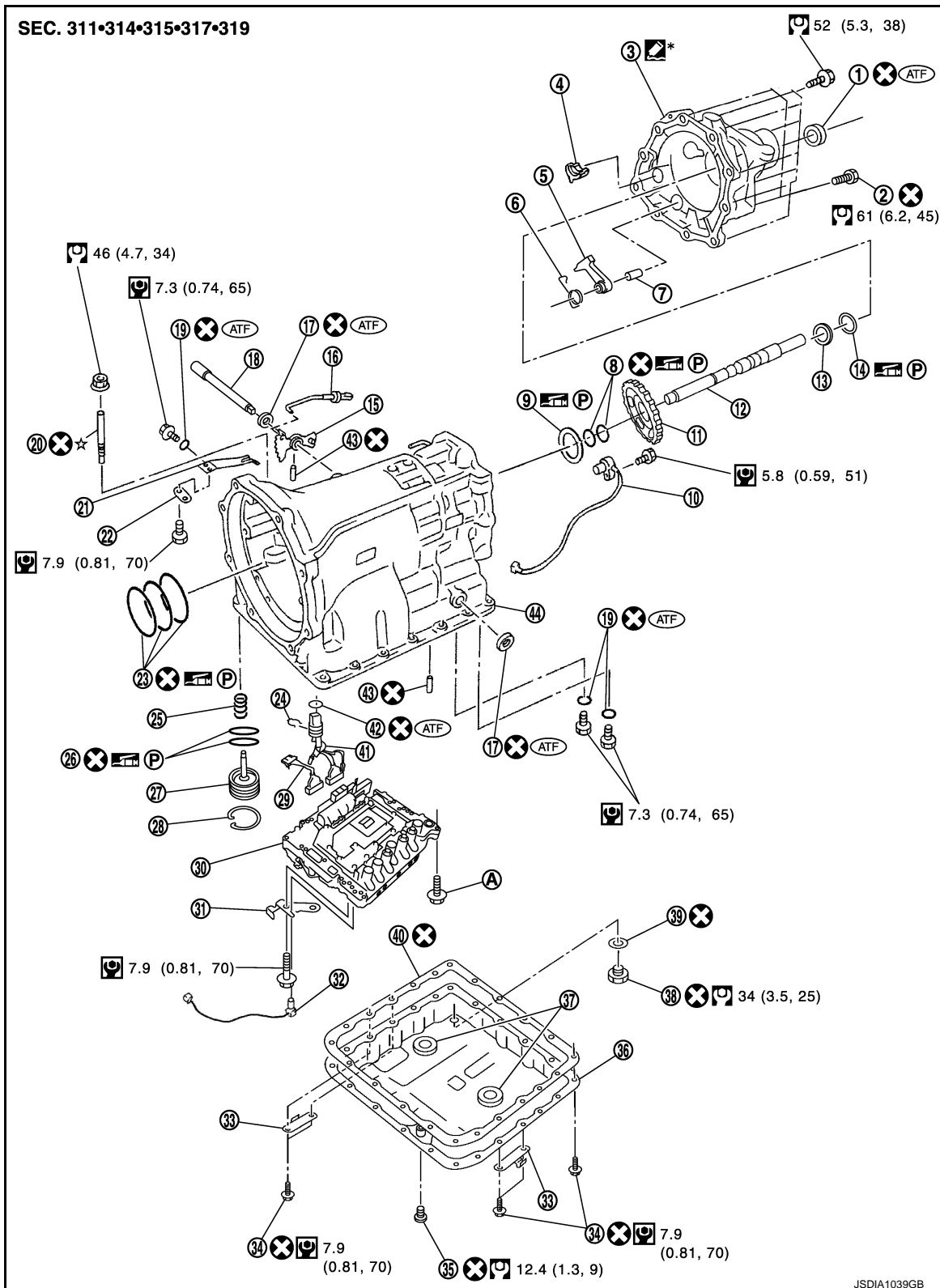

1. Rear oil seal

2. Self-sealing bolt

3. Rear extension

4. Parking actuator support

5. Parking pawl

6. Return spring

7. Pawl shaft

8. Seal ring

9. Needle bearing

10. Output speed sensor

11. Parking gear

12. Output shaft

TRANSMISSION ASSEMBLY

< UNIT DISASSEMBLY AND ASSEMBLY >

[5AT: RE5R05A]

- | | | |
|---------------------------|------------------------------------|----------------------------|
| 13. Bearing race | 14. Needle bearing | 15. Manual plate |
| 16. Parking rod | 17. Manual shaft oil seal | 18. Manual shaft |
| 19. O-ring | 20. Band servo anchor end pin | 21. Detent spring |
| 22. Spacer | 23. Seal ring | 24. Snap ring |
| 25. Return spring | 26. O-ring | 27. Servo assembly |
| 28. Snap ring | 29. Sub-harness | 30. Control valve with TCM |
| 31. Bracket | 32. A/T fluid temperature sensor 2 | 33. Clip |
| 34. Oil pan mounting bolt | 35. Overflow plug | 36. Oil pan |
| 37. Magnet | 38. Drain plug | 39. Drain plug gasket |
| 40. Oil pan gasket | 41. Terminal cord assembly | 42. O-ring |
| 43. Retaining pin | 44. Transmission case | |

A. For tightening torque, refer to [TM-229, "Assembly"](#).

: Apply Genuine Anaerobic Liquid Gasket or equivalent. Refer to [GI-17, "Recommended Chemical Products and Sealants"](#). Refer to [GI-4, "Components"](#) for symbols not described on the above.

A

B

C

TM

E

F

G

H

I

J

K

L

M

N

O

P

TRANSMISSION ASSEMBLY

< UNIT DISASSEMBLY AND ASSEMBLY >

[5AT: RE5R05A]

AWD

SEC. 313•314•315•316•317•319

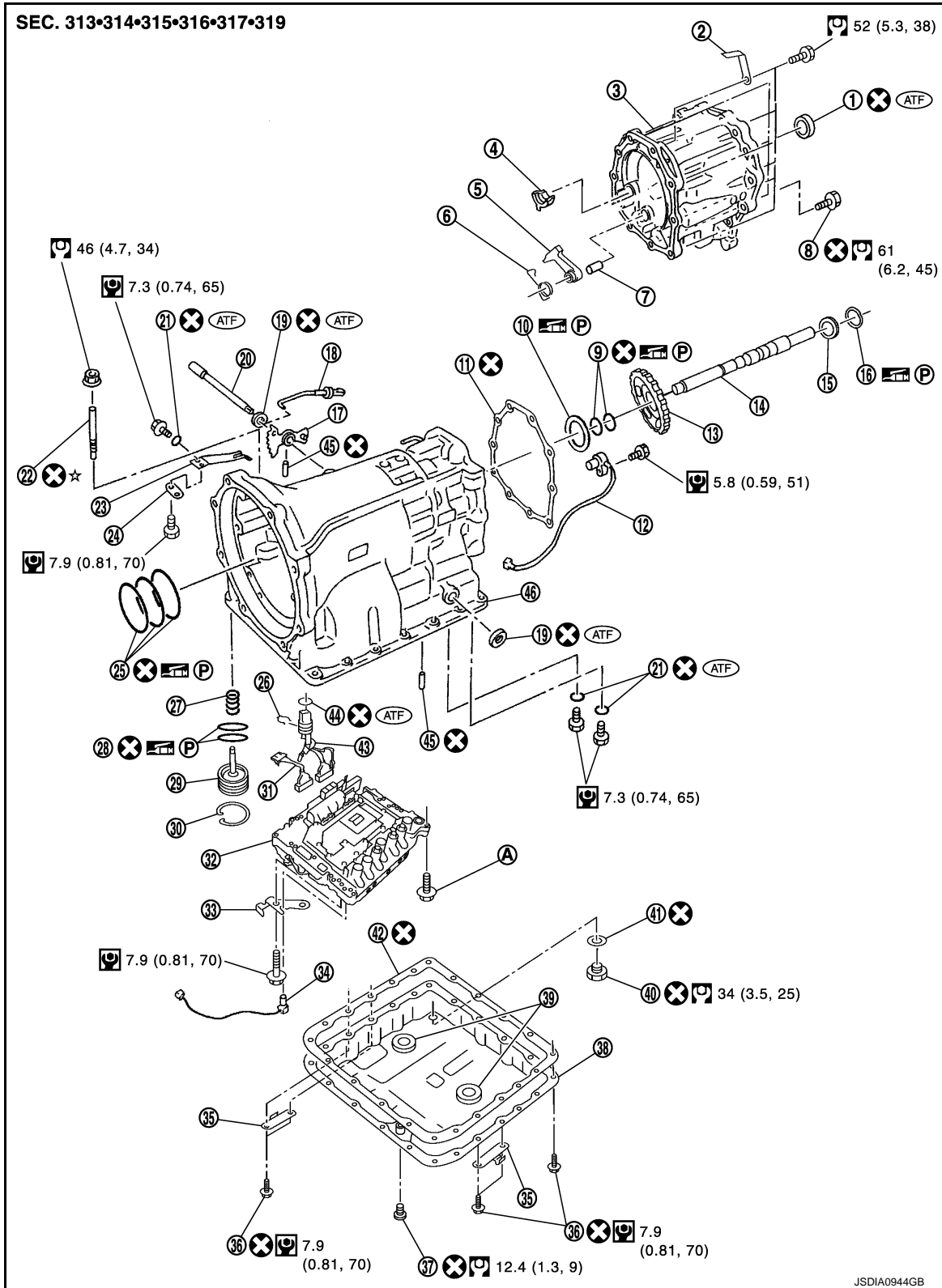

JSDIA0944GB

- | | | |
|-----------------------------|----------------------|-------------------------|
| 1. Rear oil seal | 2. Bracket | 3. Adapter case |
| 4. Parking actuator support | 5. Parking pawl | 6. Return spring |
| 7. Pawl shaft | 8. Self-sealing bolt | 9. Seal ring |
| 10. Needle bearing | 11. Gasket | 12. Output speed sensor |
| 13. Parking gear | 14. Output shaft | 15. Bearing race |
| 16. Needle bearing | 17. Manual plate | 18. Parking rod |

TRANSMISSION ASSEMBLY

< UNIT DISASSEMBLY AND ASSEMBLY >

[5AT: RE5R05A]

- | | | |
|------------------------------------|----------------------------|---------------------------|
| 19. Manual shaft oil seal | 20. Manual shaft | 21. O-ring |
| 22. Band servo anchor end pin | 23. Detent spring | 24. Spacer |
| 25. Seal ring | 26. Snap ring | 27. Return spring |
| 28. O-ring | 29. Servo assembly | 30. Snap ring |
| 31. Sub-harness | 32. Control valve with TCM | 33. Bracket |
| 34. A/T fluid temperature sensor 2 | 35. Clip | 36. Oil pan mounting bolt |
| 37. Overflow plug | 38. Oil pan | 39. Magnet |
| 40. Drain plug | 41. Drain plug gasket | 42. Oil pan gasket |
| 43. Terminal cord assembly | 44. O-ring | 45. Retaining pin |
| 46. Transmission case | | |

A. For tightening torque, refer to [TM-229, "Assembly"](#).

Refer to [GI-4, "Components"](#) for symbols in the figure.

A

B

C

TM

E

F

G

H

I

J

K

L

M

N

O

P

TRANSMISSION ASSEMBLY

< UNIT DISASSEMBLY AND ASSEMBLY >

[5AT: RE5R05A]

INFOID:000000004343051

Oil Channel

2WD

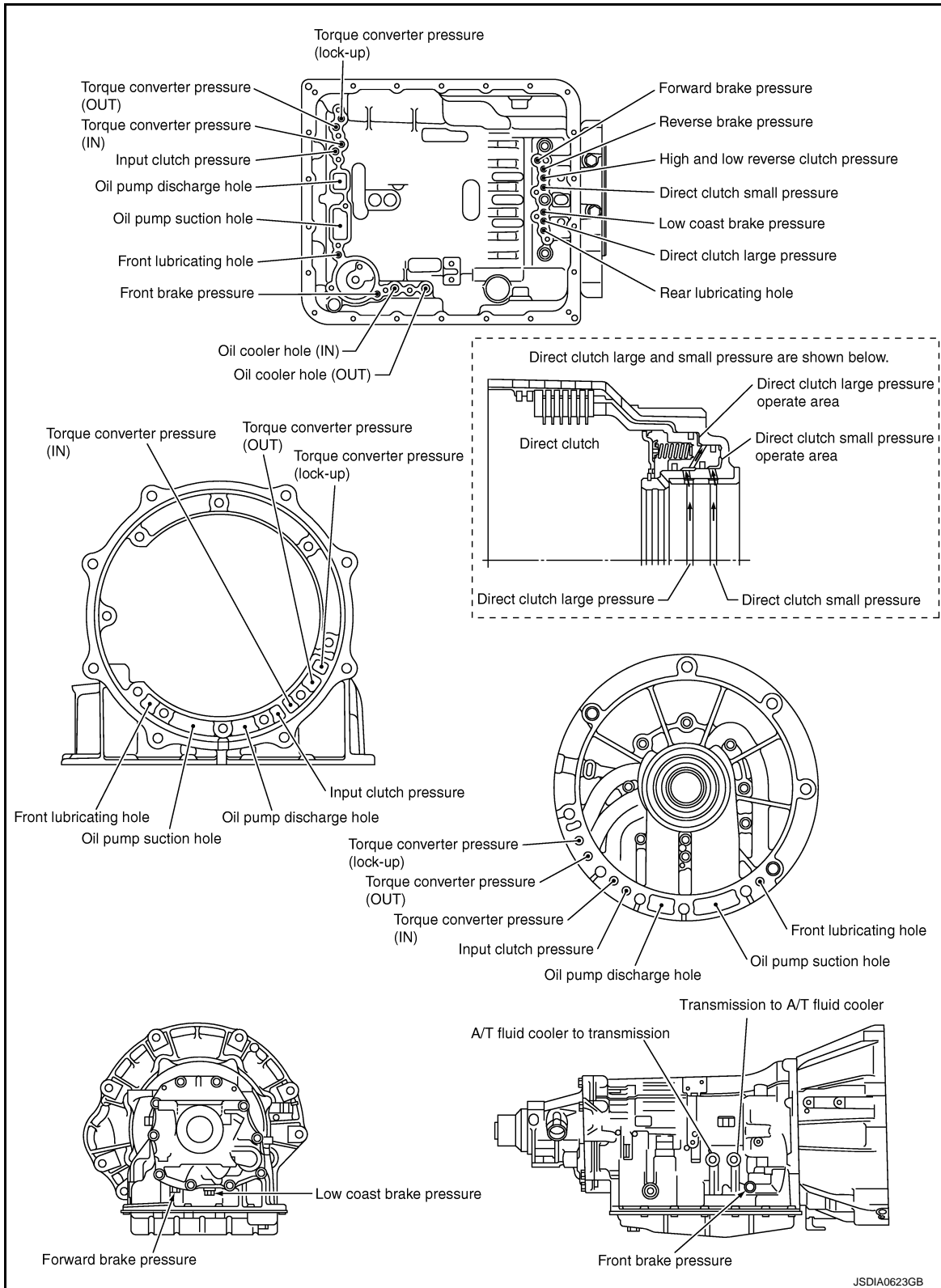

TRANSMISSION ASSEMBLY

< UNIT DISASSEMBLY AND ASSEMBLY >

[5AT: RE5R05A]

AWD

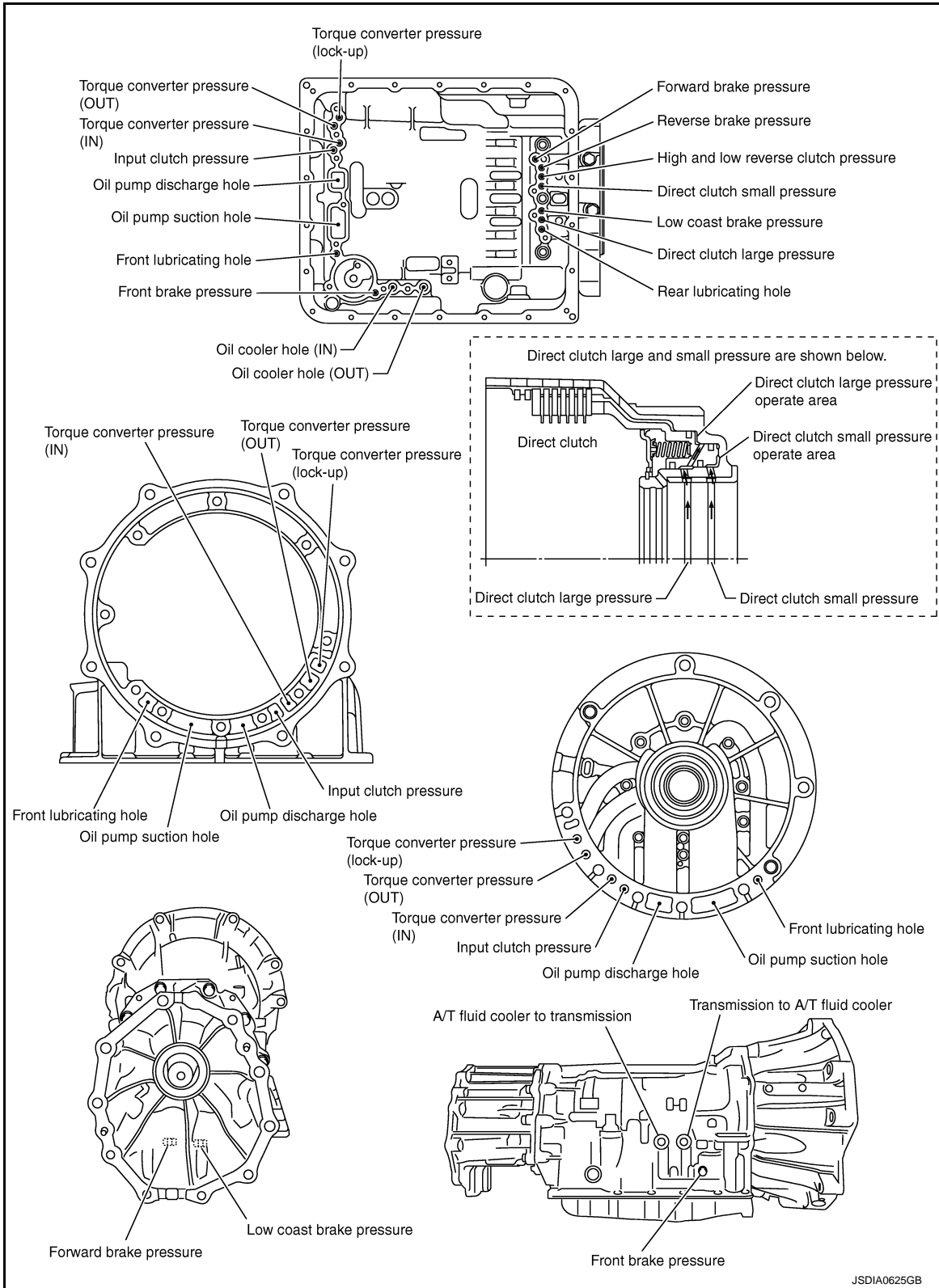

A
B
C
TM
E
F
G
H
I
J
K
L
M
N
O
P

TRANSMISSION ASSEMBLY

< UNIT DISASSEMBLY AND ASSEMBLY >

[5AT: RE5R05A]

Location of Adjusting Shims, Needle Bearings, Thrust Washers and Snap Rings

INFOID:000000004343052

2WD

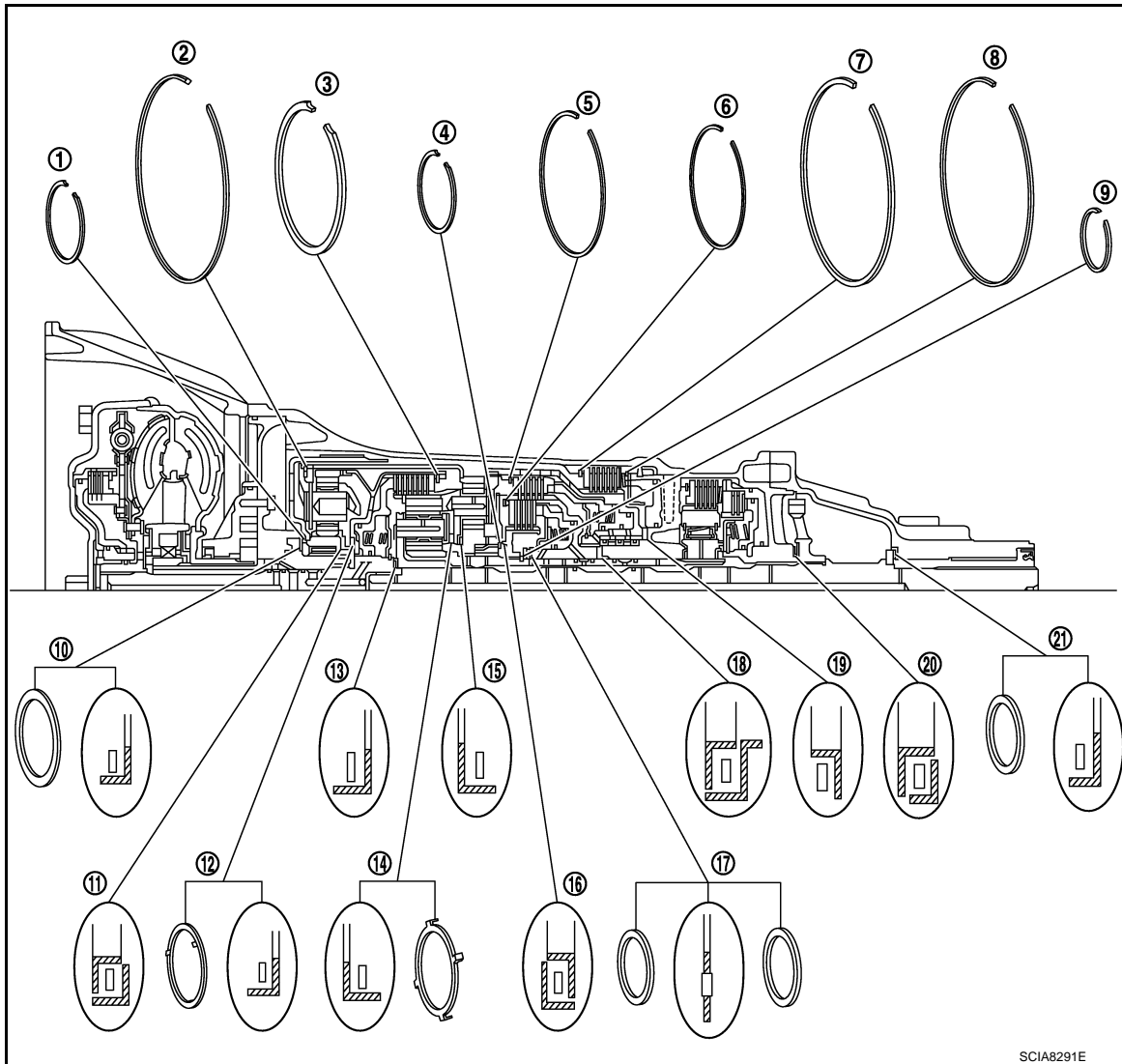

Snap ring		Needle bearing	
Item number	Outer diameter mm (in)	Item number	Outer diameter mm (in)
1	67.5 (2.657)	10	80 (3.149)
2	182.4 (7.181)	11	77 (3.031)
3	171.5 (6.751)	12	77 (3.031)
4	70.5 (2.776)	13	47 (1.850)
5	169 (6.653)	14	84 (3.307)
6	134.3 (5.287)	15	84 (3.307)
7	180.5 (7.106)	16	92 (3.622)
8	181 (7.125)	17	60 (2.362)
9	48.4 (1.906)	18	63 (2.480)
—	—	19	92 (3.622)
—	—	20	65 (2.559)
—	—	21	60 (2.362)

TRANSMISSION ASSEMBLY

< UNIT DISASSEMBLY AND ASSEMBLY >

[5AT: RE5R05A]

AWD

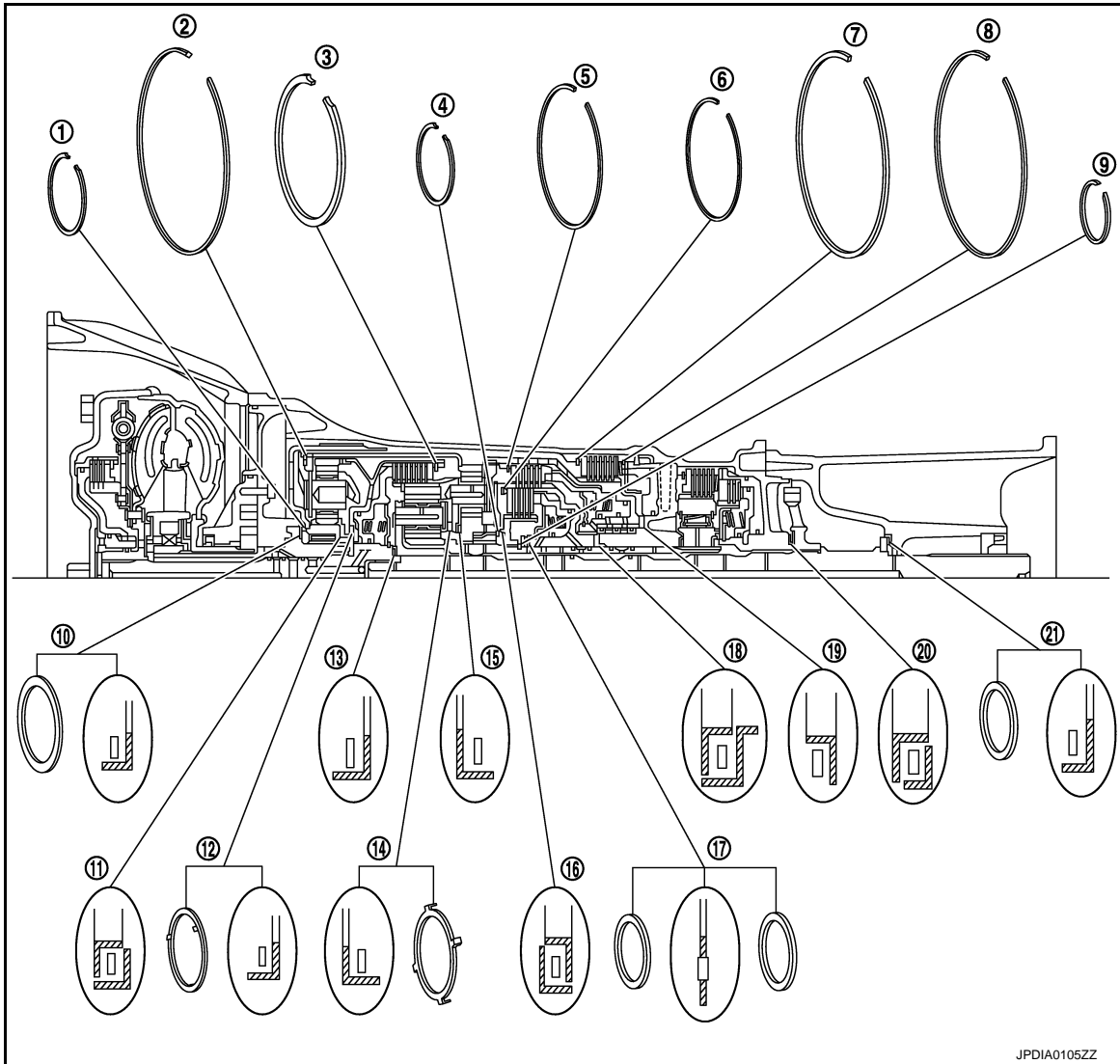

JPDIA0105ZZ

Snap ring		Needle bearing	
Item number	Outer diameter mm (in)	Item number	Outer diameter mm (in)
1	67.5 (2.657)	10	80 (3.149)
2	182.4 (7.181)	11	77 (3.031)
3	171.5 (6.751)	12	77 (3.031)
4	70.5 (2.776)	13	47 (1.850)
5	169 (6.653)	14	84 (3.307)
6	134.3 (5.287)	15	84 (3.307)
7	180.5 (7.106)	16	92 (3.622)
8	181 (7.125)	17	60 (2.362)
9	48.4 (1.906)	18	63 (2.480)
—	—	19	92 (3.622)
—	—	20	65 (2.559)
—	—	21	60 (2.362)

Disassembly

INFOID:000000004343053

CAUTION:

Do not disassemble parts behind Drum Support. Refer to [TM-19, "Cross-Sectional View"](#).

TRANSMISSION ASSEMBLY

< UNIT DISASSEMBLY AND ASSEMBLY >

[5AT: RE5R05A]

1. Drain ATF through drain plug.
2. Remove torque converter by holding it firmly and turning while pulling straight out.

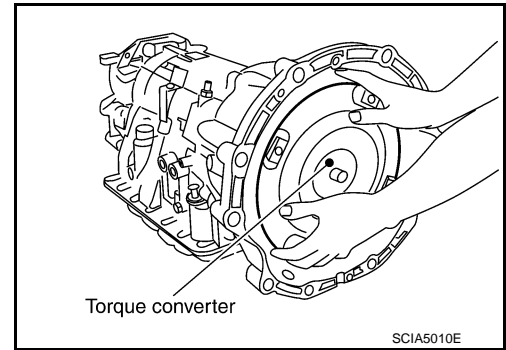

3. Remove tightening bolts (◀) for converter housing and transmission case.
4. Remove converter housing from transmission case.
CAUTION:
Be careful not to scratch converter housing.

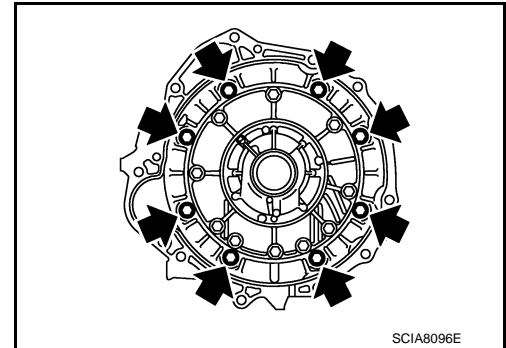

5. Remove O-ring from input clutch assembly.

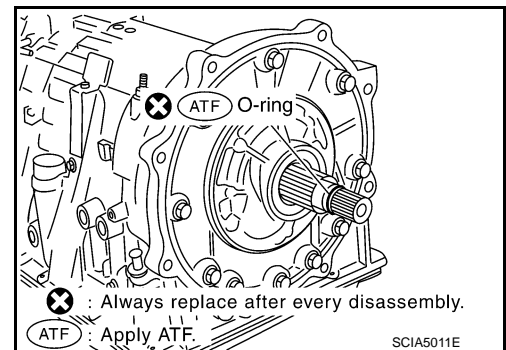

6. Remove tightening bolts for oil pump assembly and transmission case.

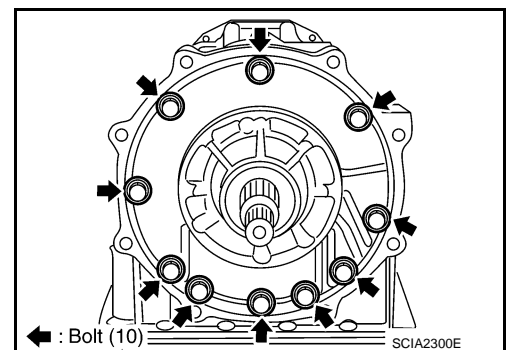

TRANSMISSION ASSEMBLY

< UNIT DISASSEMBLY AND ASSEMBLY >

[5AT: RE5R05A]

7. Attach the sliding hammers to oil pump assembly and extract it evenly from transmission case.

CAUTION:

- Fully tighten the sliding hammer screws.
- Make sure that bearing race is installed to the oil pump assembly edge surface.

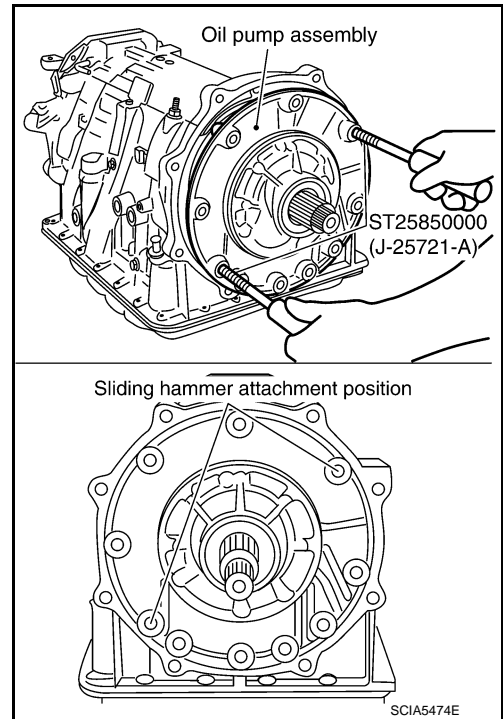

8. Remove O-ring from oil pump assembly.

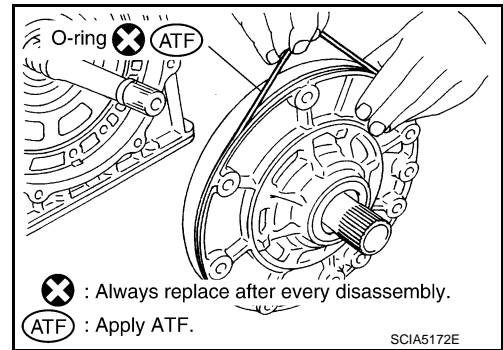

9. Remove bearing race from oil pump assembly.

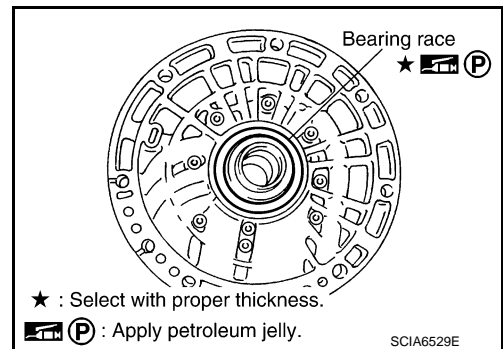

10. Remove needle bearing from front sun gear.

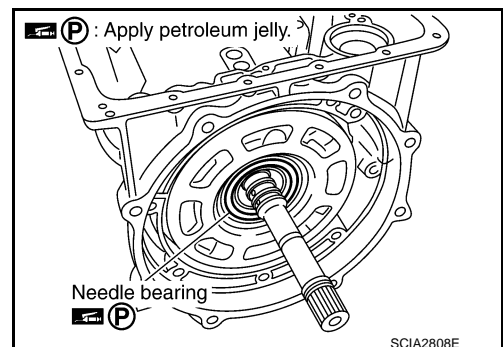

A
B
C
TM
E
F
G
H
I
J
K
L
M
N
O
P

TRANSMISSION ASSEMBLY

< UNIT DISASSEMBLY AND ASSEMBLY >

[5AT: RE5R05A]

11. Remove front sun gear assembly from front carrier assembly.

NOTE:

Remove front sun gear by rotating left/right.

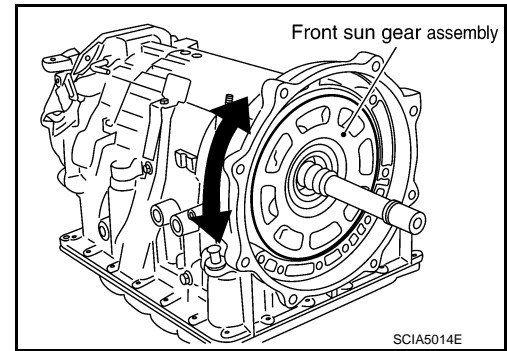

12. Remove seal rings from input clutch assembly.

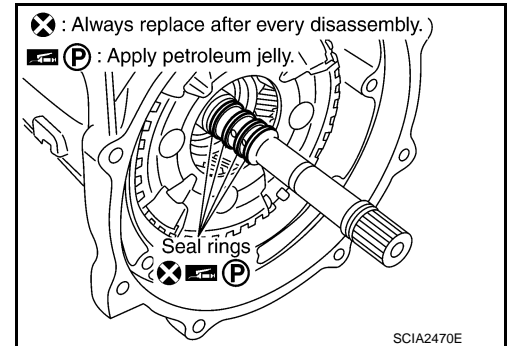

13. Remove front carrier assembly from rear carrier assembly. (With input clutch assembly and rear internal gear.)

CAUTION:

Be careful to remove it with needle bearing.

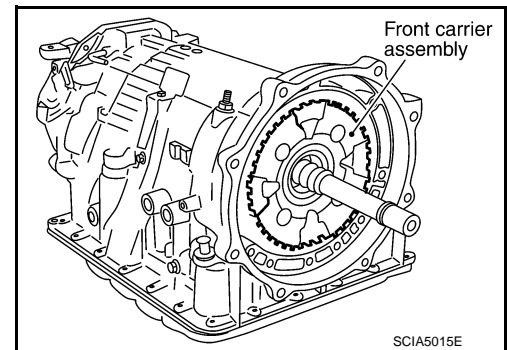

14. Loosen lock nut and remove band servo anchor end pin from transmission case.

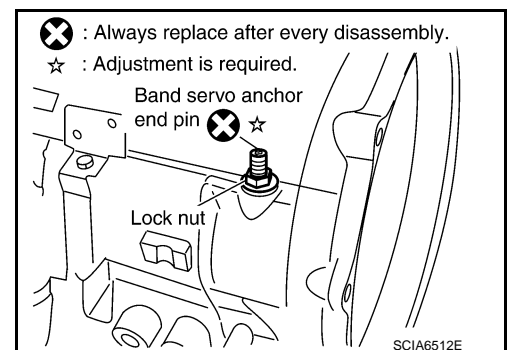

15. Remove brake band from transmission case.

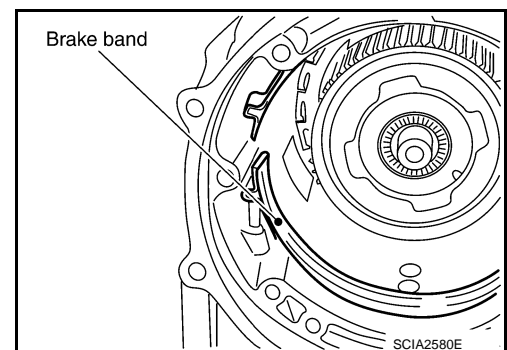

TRANSMISSION ASSEMBLY

< UNIT DISASSEMBLY AND ASSEMBLY >

[5AT: RE5R05A]

- To prevent brake linings from cracking or peeling, do not stretch the flexible band unnecessarily. When removing the brake band, always secure it with a clip as shown in the figure at right. Leave the clip in position after removing the brake band.
- Check brake band facing for damage, cracks, wear or burns.

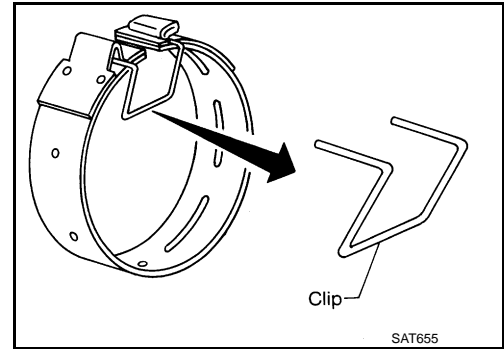

16. Remove mid carrier assembly and rear carrier assembly as a unit.

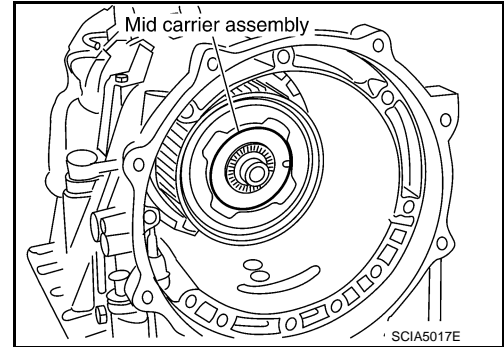

17. Remove mid carrier assembly from rear carrier assembly.

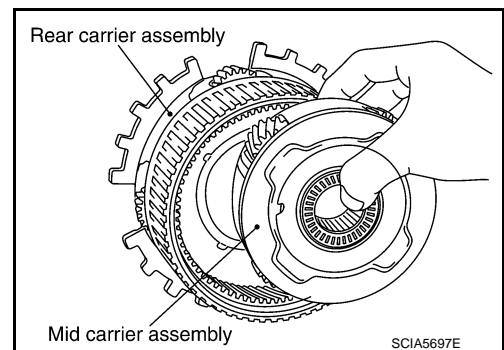

18. Remove needle bearing (front side) from mid carrier assembly.

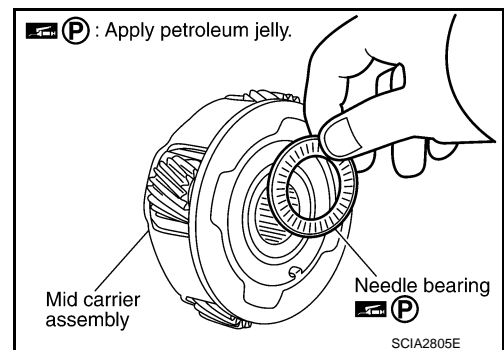

19. Remove needle bearing (rear side) from mid carrier assembly.

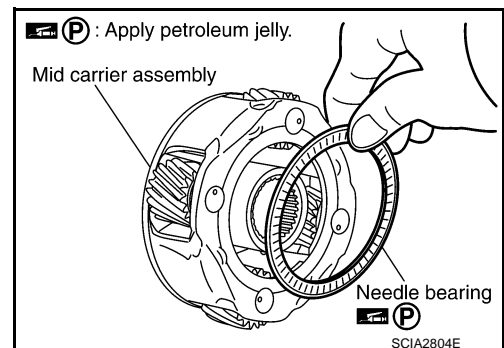

A
B
C
TM
E
F
G
H
I
J
K
L
M
N
O
P

TRANSMISSION ASSEMBLY

< UNIT DISASSEMBLY AND ASSEMBLY >

[5AT: RE5R05A]

20. Remove bearing race from rear carrier assembly.

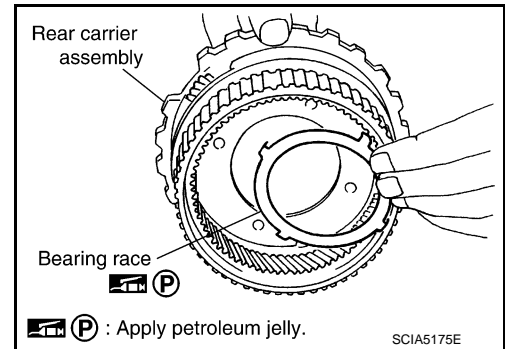

21. Remove needle bearing from rear carrier assembly.

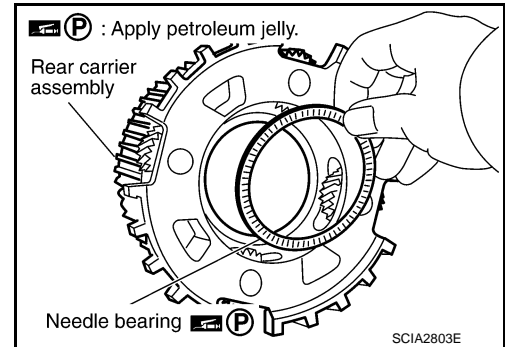

22. Remove mid sun gear assembly, rear sun gear assembly and high and low reverse clutch hub as a unit.

CAUTION:

Be careful to remove them with bearing race and needle bearing.

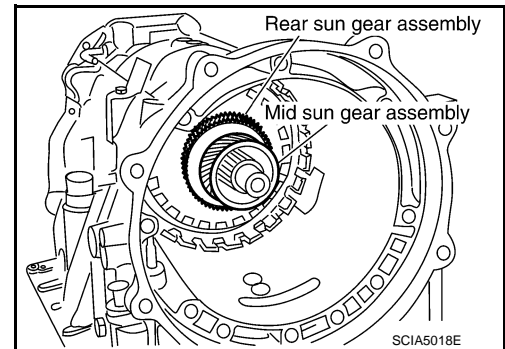

23. Remove high and low reverse clutch assembly from direct clutch assembly.

CAUTION:

Make sure that needle bearing is installed to the high and low reverse clutch assembly edge surface.

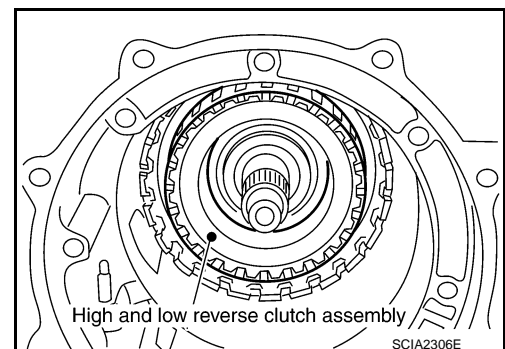

24. Remove direct clutch assembly from reverse brake.

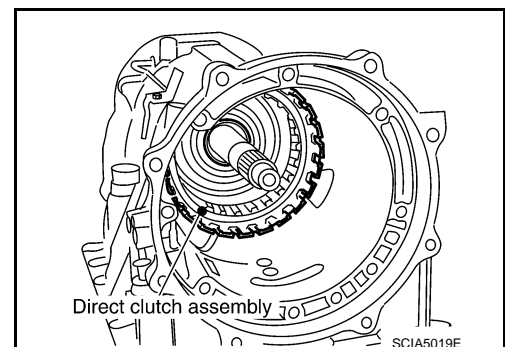

TRANSMISSION ASSEMBLY

< UNIT DISASSEMBLY AND ASSEMBLY >

[5AT: RE5R05A]

25. Remove needle bearing from drum support.

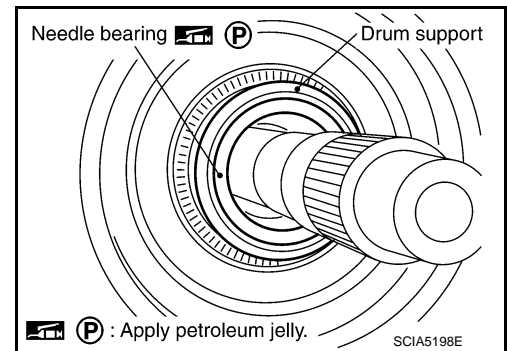

26. Remove snap ring (1) from A/T assembly connector (A).

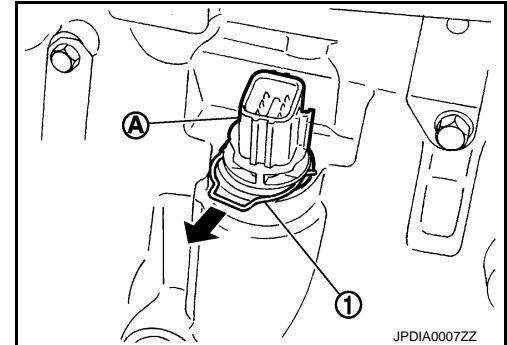

27. Push A/T assembly connector (A).

CAUTION:
Be careful not to damage connector.

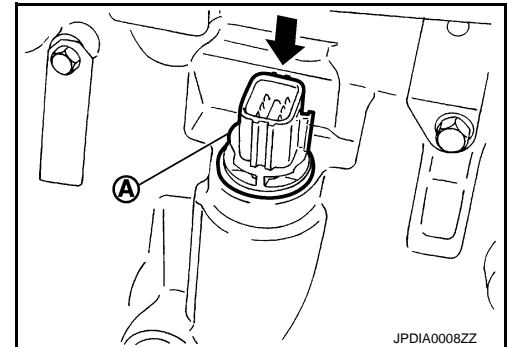

28. Remove clips (1).

↔ : Front

← : Oil pan mounting bolt

29. Remove oil pan (2) and oil pan gasket.

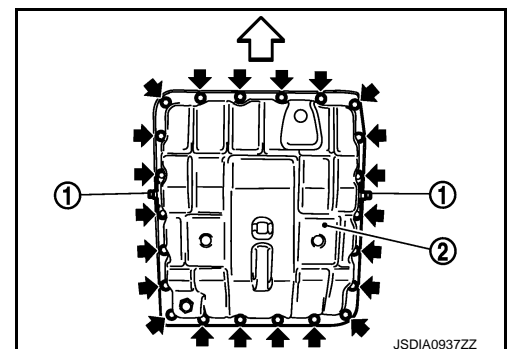

30. Remove magnets (1) from oil pan.

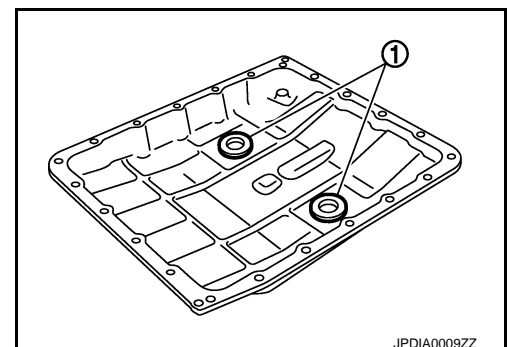

A
B
C
TM
E
F
G
H
I
J
K
L
M
N
O
P

TRANSMISSION ASSEMBLY

< UNIT DISASSEMBLY AND ASSEMBLY >

[5AT: RE5R05A]

31. Disconnect A/T fluid temperature sensor 2 connector (A).

CAUTION:

Be careful not to damage connector.

32. Disengage terminal clips (←).

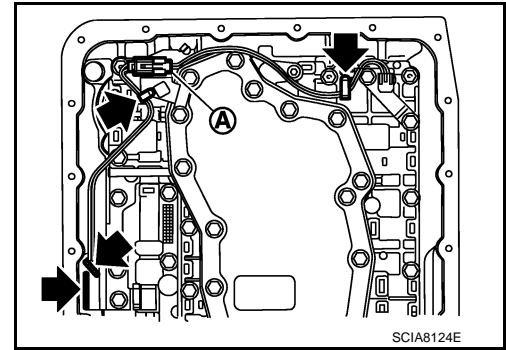

33. Disconnect output speed sensor connector (A).

CAUTION:

Be careful not to damage connector.

34. Disengage terminal clip (←).

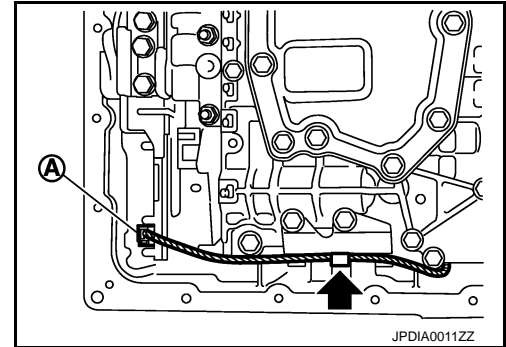

35. Remove bolts (A), (B) and (C) from control valve with TCM.

← : Front

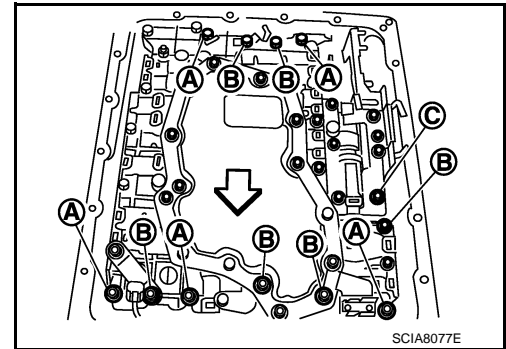

36. Remove control valve with TCM from transmission case.

CAUTION:

When removing, be careful with the manual valve notch and manual plate height. Remove it vertically.

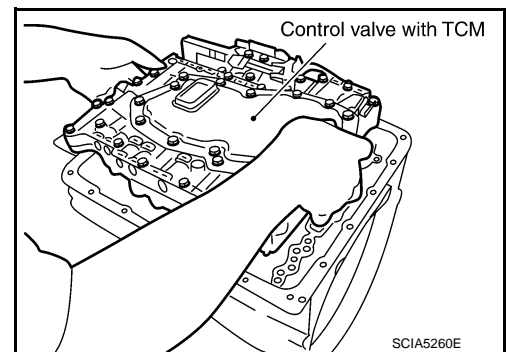

37. Remove A/T fluid temperature sensor 2 (1) with bracket (2) from control valve with TCM.

← : Bolt

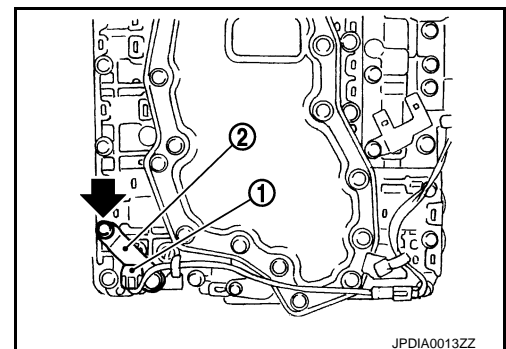

TRANSMISSION ASSEMBLY

< UNIT DISASSEMBLY AND ASSEMBLY >

[5AT: RE5R05A]

38. Remove bracket (1) from A/T fluid temperature sensor 2 (2).

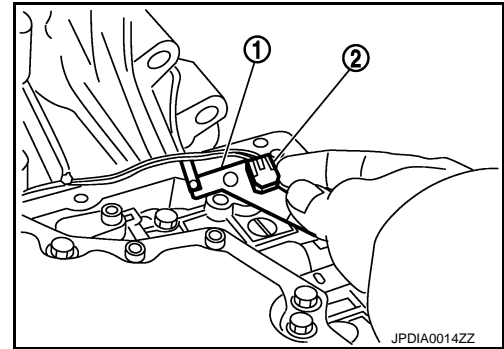

39. Remove O-ring (1) from A/T assembly connector (A).

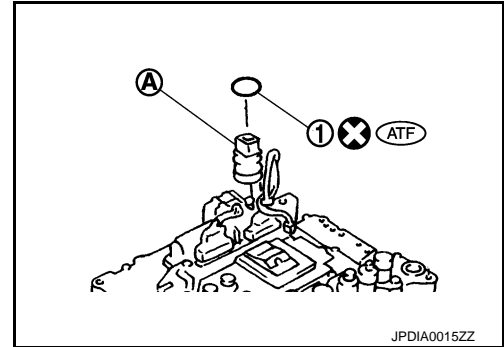

40. Disconnect TCM connectors (A) and (B).

CAUTION:

Be careful not to damage connectors.

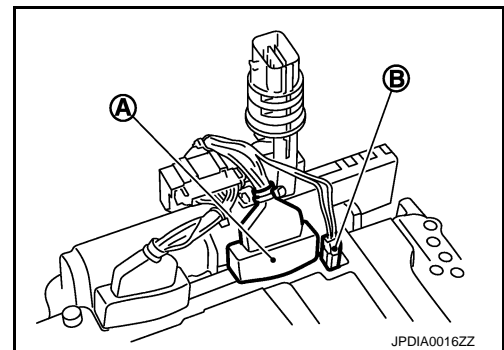

41. Remove A/T assembly connector (A) from control valve with TCM with a flat-bladed screwdriver (B).

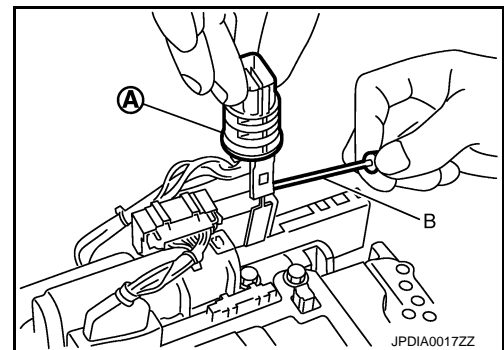

42. Disconnect TCM connector (A) and transmission range switch connector (B).

CAUTION:

Be careful not to damage connectors.

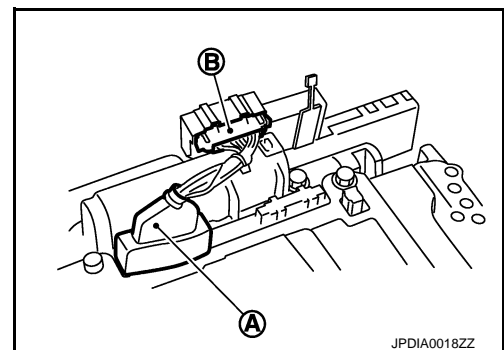

A
B
C
TM
E
F
G
H
I
J
K
L
M
N
O
P

TRANSMISSION ASSEMBLY

< UNIT DISASSEMBLY AND ASSEMBLY >

[5AT: RE5R05A]

43. Remove rear extension assembly (2WD) or adapter case assembly (AWD) according to the following procedures.

a. **2WD**

i. Remove tightening bolts for rear extension assembly and transmission case.

1 : Self-sealing bolt

A : Bolt

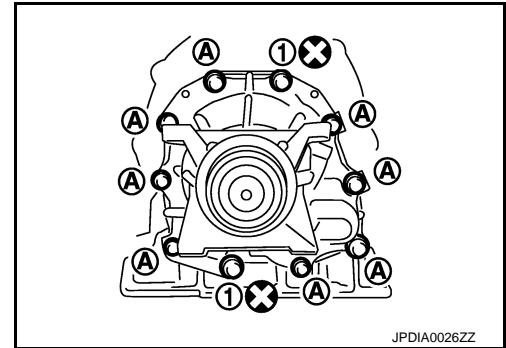

ii. Tap rear extension assembly with a soft hammer.

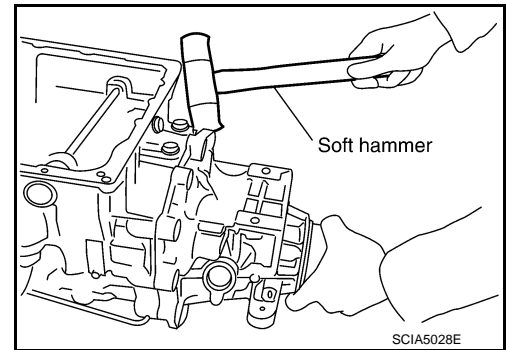

iii. Remove rear extension assembly from transmission case. (With needle bearing).

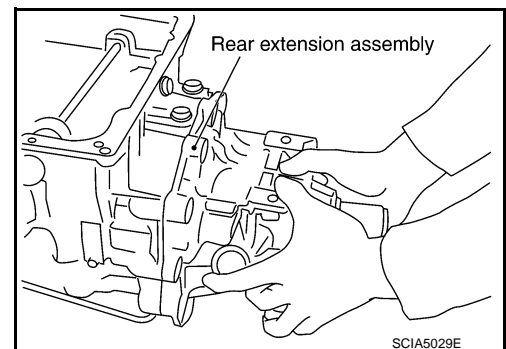

iv. Remove bearing race from output shaft.

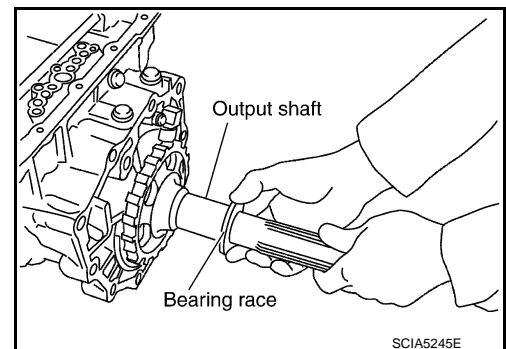

TRANSMISSION ASSEMBLY

< UNIT DISASSEMBLY AND ASSEMBLY >

[5AT: RE5R05A]

- v. Remove output shaft from transmission case by rotating left/right.

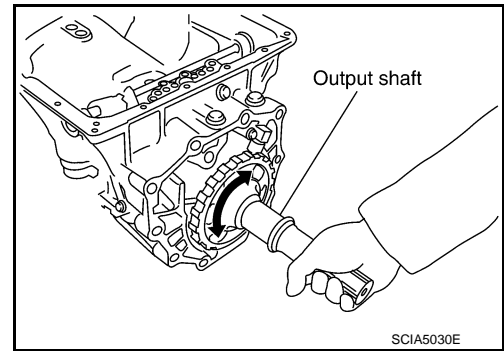

- vi. Remove parking gear (1) from output shaft (2).

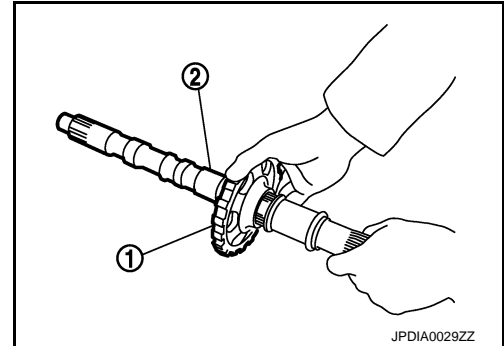

- vii. Remove seal rings (1) from output shaft.

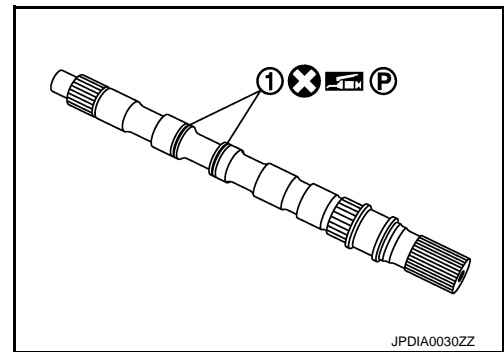

- b. AWD

A
B
C
TM
E
F
G
H
I
J
K
L
M
N
O
P

TRANSMISSION ASSEMBLY

< UNIT DISASSEMBLY AND ASSEMBLY >

[5AT: RE5R05A]

- i. Remove tightening bolts (1) for adapter case assembly and transmission case. [With bracket (2).]

3 : Self-sealing bolt

← : Bolt

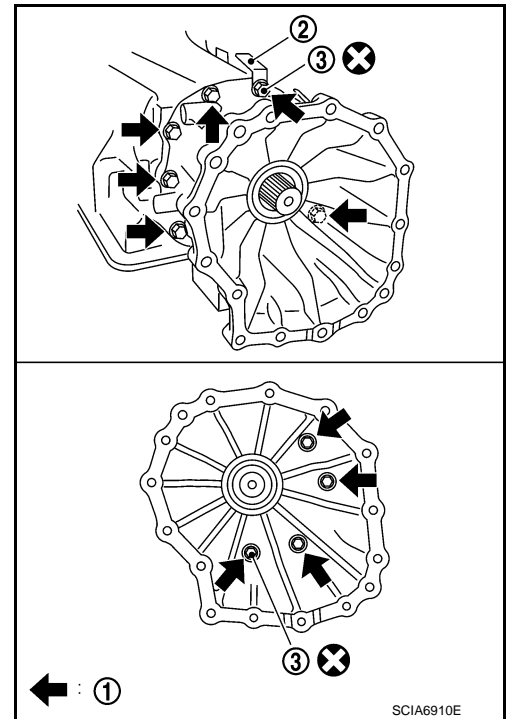

- ii. Tap adapter case assembly with a soft hammer.

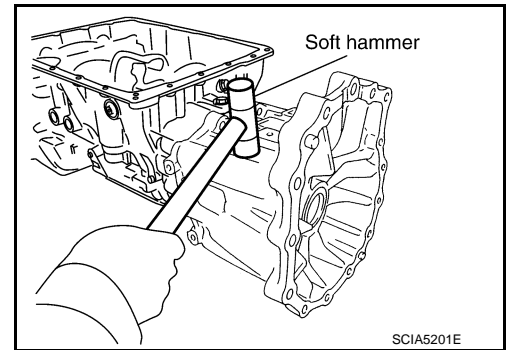

- iii. Remove adapter case assembly from transmission case. (With needle bearing)

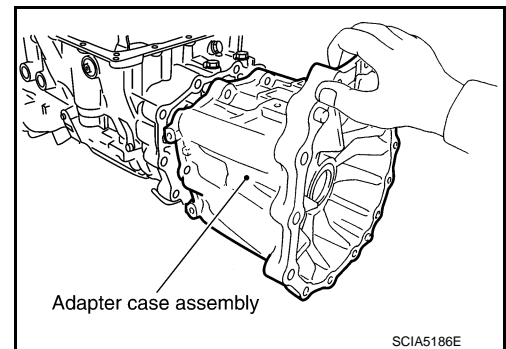

- iv. Remove gasket from transmission case.

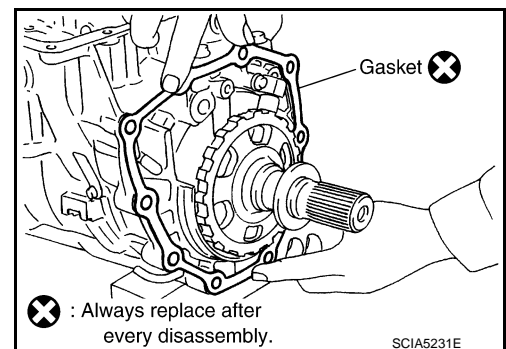

TRANSMISSION ASSEMBLY

< UNIT DISASSEMBLY AND ASSEMBLY >

[5AT: RE5R05A]

v. Remove bearing race from output shaft.

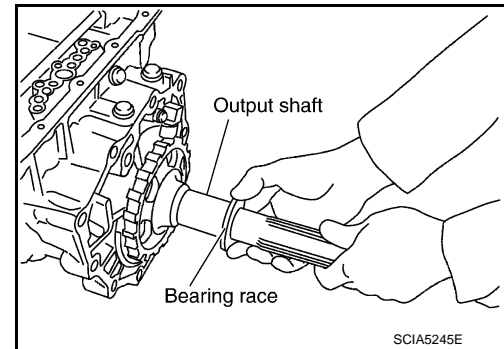

vi. Remove output shaft from transmission case by rotating left/right.

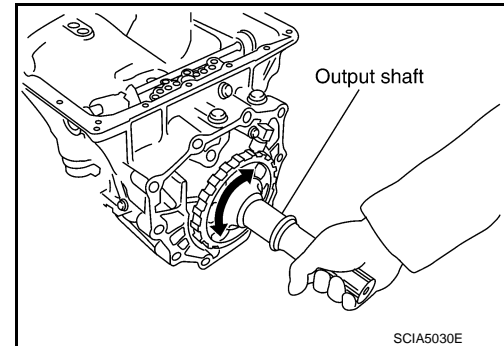

vii. Remove parking gear (1) from output shaft (2).

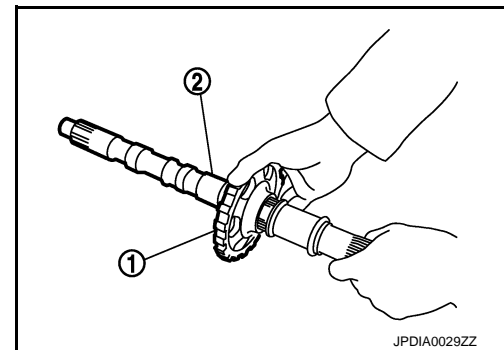

viii. Remove seal rings (1) from output shaft.

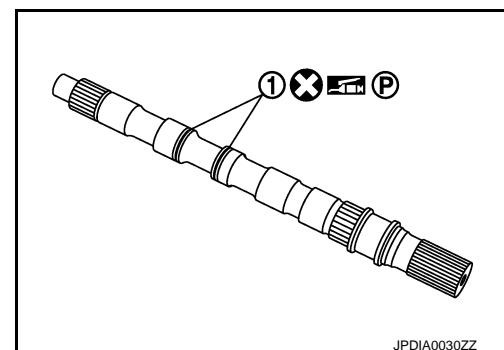

44. Remove needle bearing from transmission case.

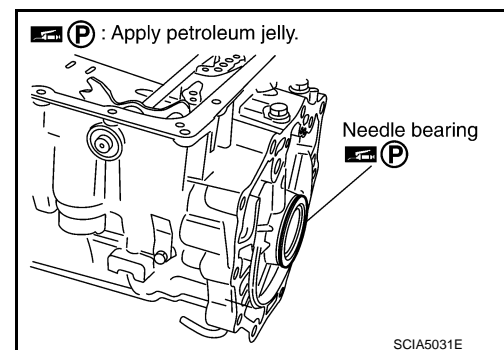

A
B
C
TM
E
F
G
H
I
J
K
L
M
N
O
P

TRANSMISSION ASSEMBLY

< UNIT DISASSEMBLY AND ASSEMBLY >

[5AT: RE5R05A]

45. Remove output speed sensor (1) from transmission case.

CAUTION:

- Never subject it to impact by dropping or hitting it.
- Never disassemble.
- Never allow metal filings, etc. to get on the sensor's front edge magnetic area.
- Never place in an area affected by magnetism.

← : Bolt

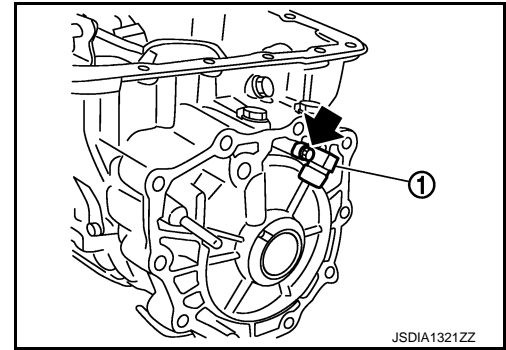

46. Remove reverse brake snap ring (fixing plate) with two flat-bladed screwdrivers.

NOTE:

Press out snap ring from the transmission case oil pan side gap using a flat-bladed screwdriver, and remove it using a another screwdriver.

47. Remove reverse brake retaining plate from transmission case.

- Check facing for burns, cracks or damage. If necessary, replace the plate.

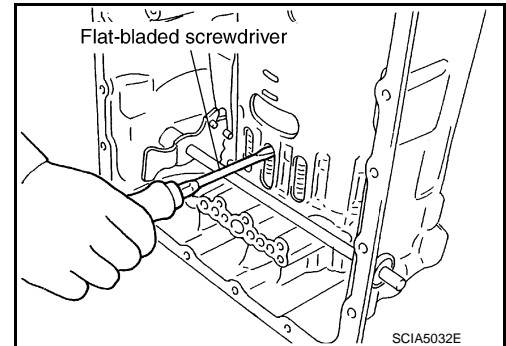

48. Remove N-spring from transmission case.

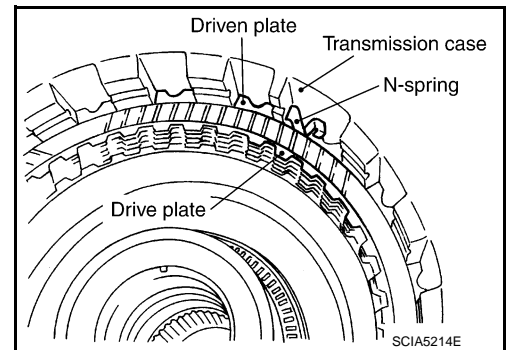

49. Remove reverse brake drive plates, driven plates, dish plates and retaining plate transmission case.

- Check facing for burns, cracks or damage. If necessary, replace the plate.

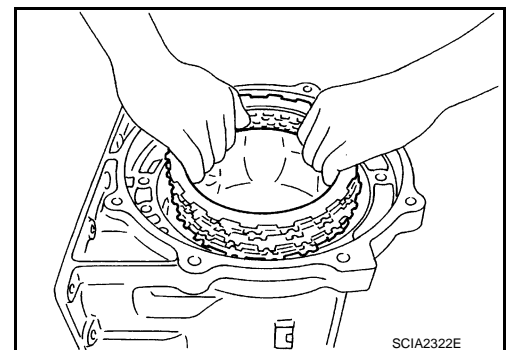

50. Remove snap ring (fixing spring retainer) using a flat-bladed screwdriver.

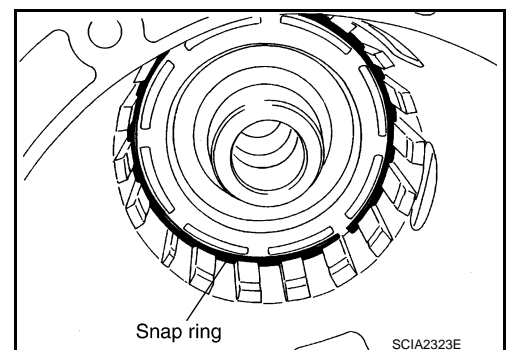

TRANSMISSION ASSEMBLY

< UNIT DISASSEMBLY AND ASSEMBLY >

[5AT: RE5R05A]

51. Remove spring retainer and return spring from transmission case.

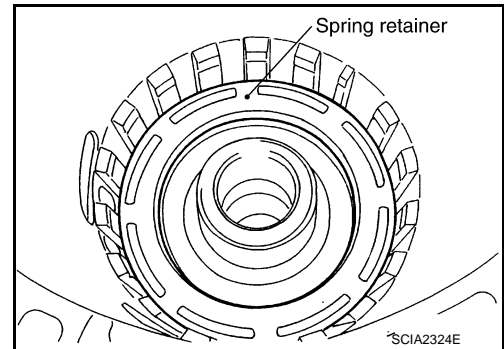

52. Remove seal rings from drum support.

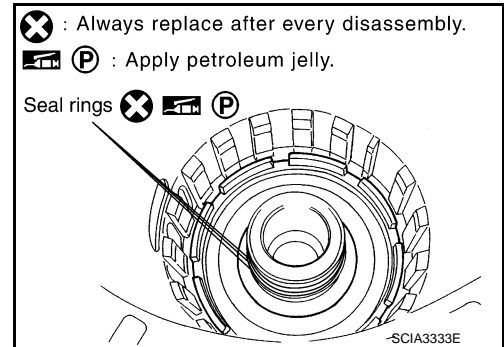

53. Remove needle bearing from drum support edge surface.

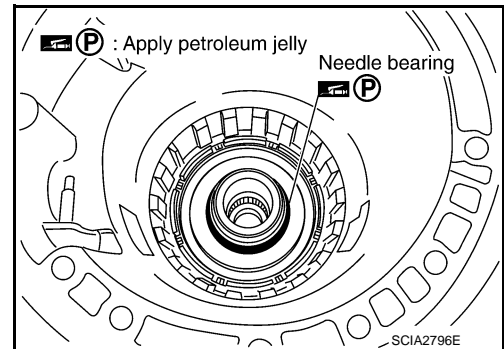

54. Remove reverse brake piston from transmission case with compressed air. Refer to [TM-208. "Oil Channel"](#).

CAUTION:

Care should be taken not to abruptly blow air. It makes pistons incline, as the result, it becomes hard to disassemble the pistons.

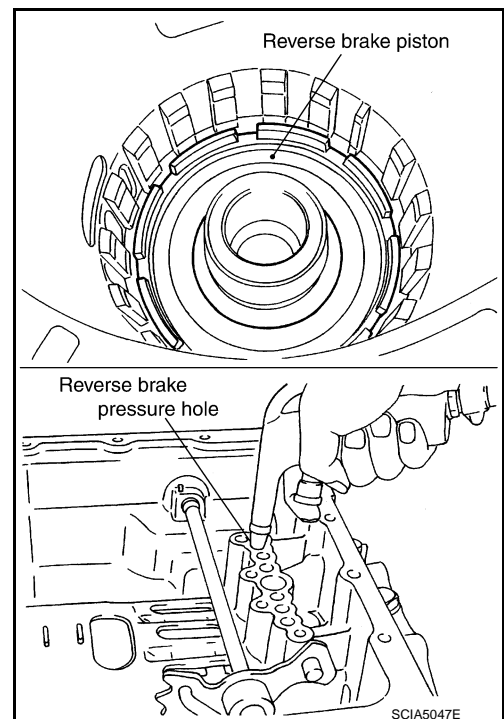

A
B
C
TM
E
F
G
H
I
J
K
L
M
N
O
P

TRANSMISSION ASSEMBLY

< UNIT DISASSEMBLY AND ASSEMBLY >

[5AT: RE5R05A]

55. Remove D-rings from reverse brake piston.

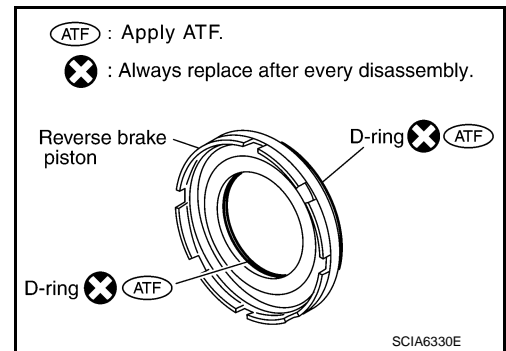

56. Use a pin punch [4 mm (0.16 in) dia. commercial service tool] to knock out retaining pin.

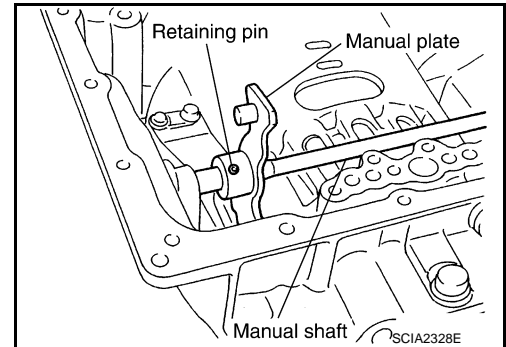

57. Remove retaining pin with pair of nippers.

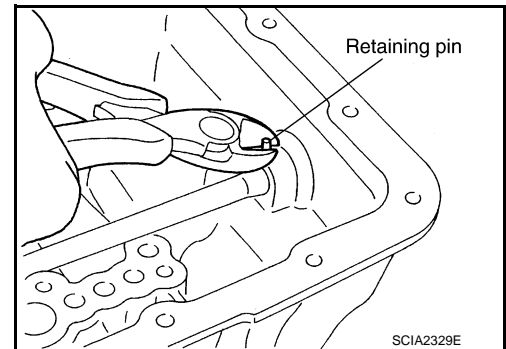

58. Remove manual plate (with parking rod) from manual shaft.

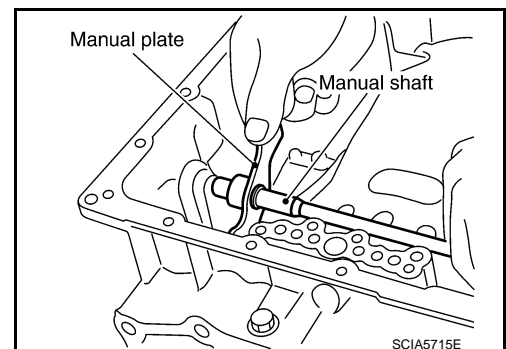

59. Remove parking rod from manual plate.

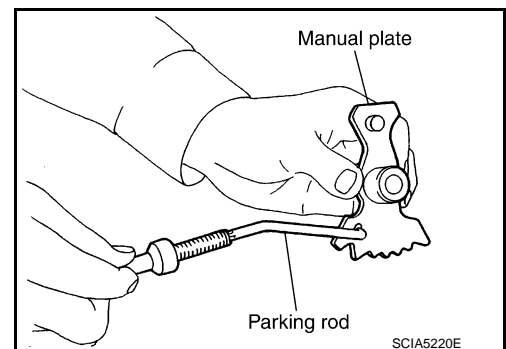

TRANSMISSION ASSEMBLY

< UNIT DISASSEMBLY AND ASSEMBLY >

[5AT: RE5R05A]

60. Remove manual shaft from transmission case.

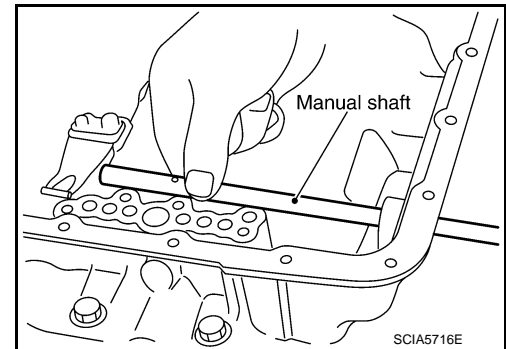

61. Remove manual shaft oil seals with a flat-bladed screwdriver.

CAUTION:

Be careful not to scratch transmission case.

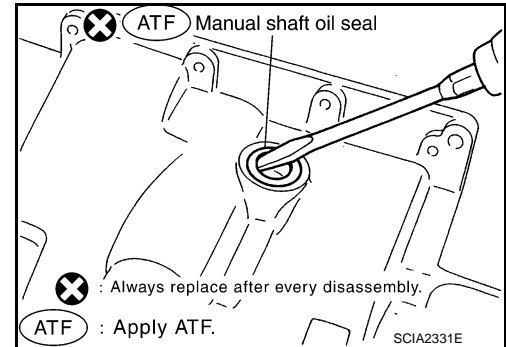

62. Remove detent spring and spacer from transmission case.

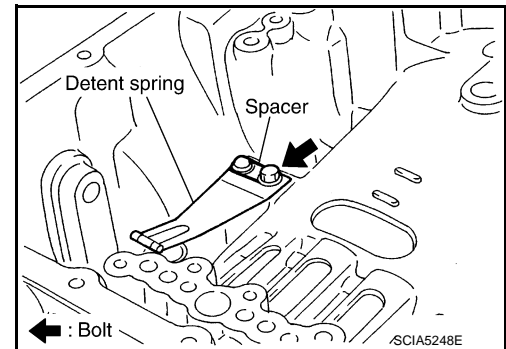

63. Remove snap ring from transmission case with pair of snap ring pliers.

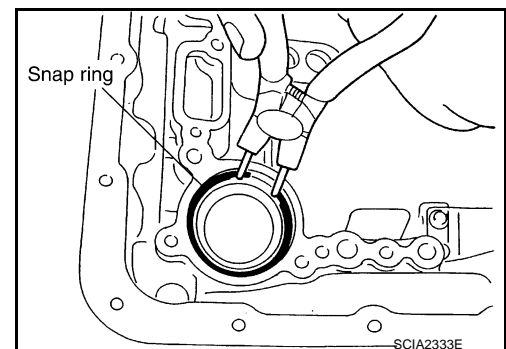

64. Remove servo assembly (with return spring) from transmission case.

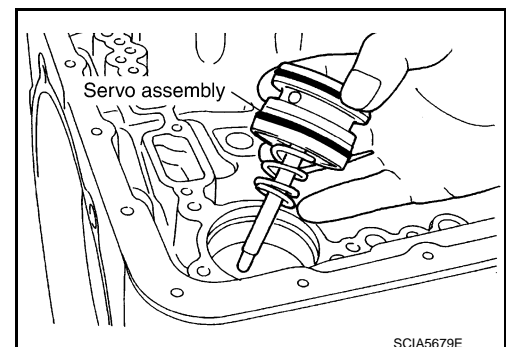

A
B
C
TM
E
F
G
H
I
J
K
L
M
N
O
P

TRANSMISSION ASSEMBLY

< UNIT DISASSEMBLY AND ASSEMBLY >

[5AT: RE5R05A]

65. Remove return spring from servo assembly.

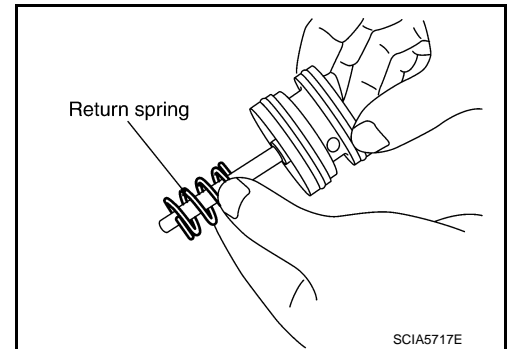

66. Remove O-rings from servo assembly.

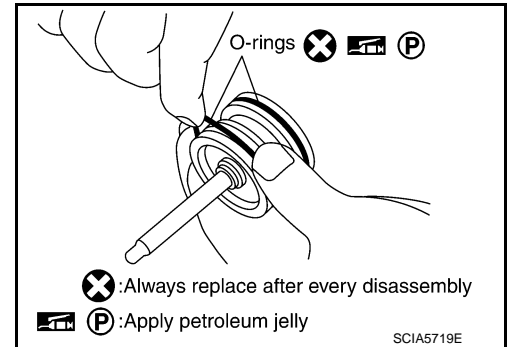

67. Remove needle bearing (1) from rear extension (2WD) or adapter case (AWD).

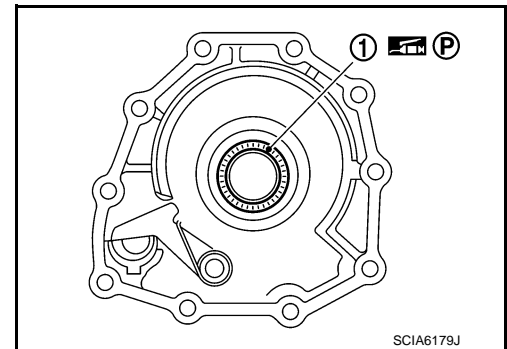

68. Remove parking actuator support from rear extension (2WD) or adapter case (AWD).

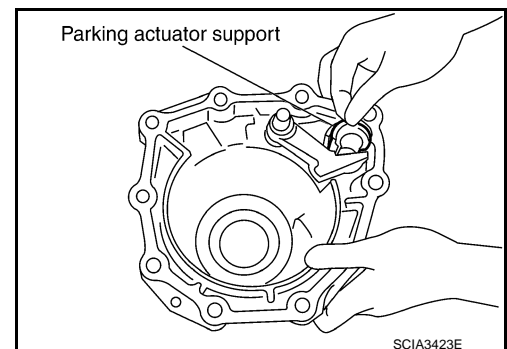

69. Remove parking pawl (with return spring) and pawl shaft from rear extension (2WD) or adapter case (AWD).

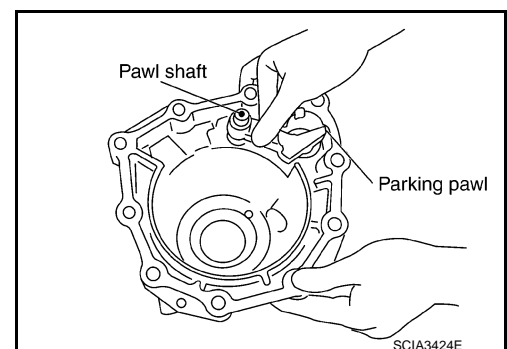

TRANSMISSION ASSEMBLY

< UNIT DISASSEMBLY AND ASSEMBLY >

[5AT: RE5R05A]

70. Remove return spring (1) from parking pawl (2).

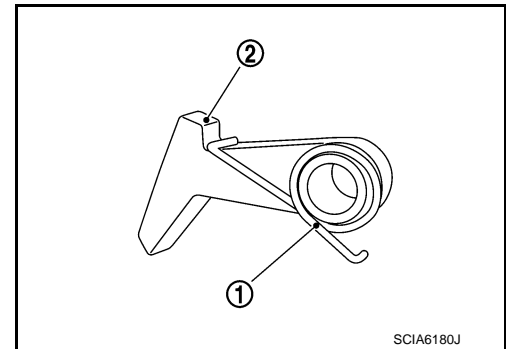

71. Remove rear oil seal from rear extension (2WD) or adapter case (AWD) with a flat-bladed screwdriver.

CAUTION:

Be careful not to scratch rear extension (2WD) or adapter case (AWD).

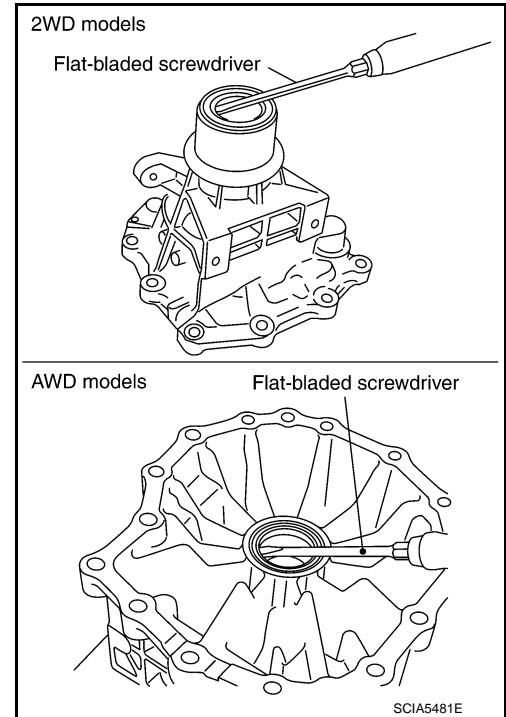

Assembly

INFOID:000000004343054

1. As shown in the figure, use a drift [22 mm (0.87 in) dia. commercial service tool] to drive manual shaft oil seals into the transmission case until it is flush.

CAUTION:

- Never reuse manual shaft oil seals.
- Apply ATF to manual shaft oil seals.

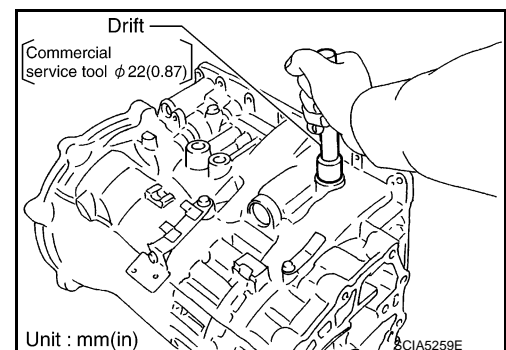

TRANSMISSION ASSEMBLY

< UNIT DISASSEMBLY AND ASSEMBLY >

[5AT: RE5R05A]

2. Install detent spring and spacer in transmission case. Tighten detent spring and spacer bolt to the specified torque.

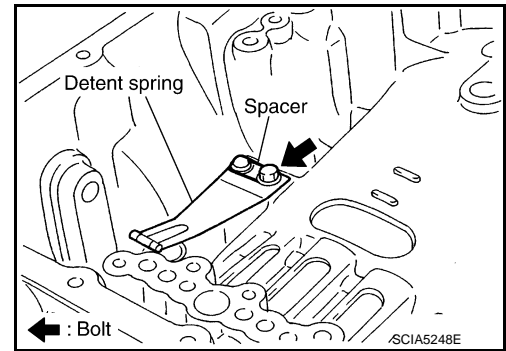

3. Install manual shaft to transmission case.

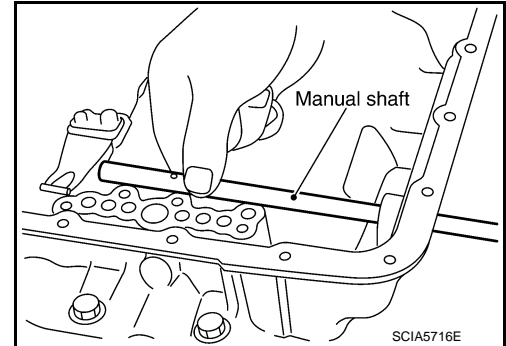

4. Install parking rod to manual plate.

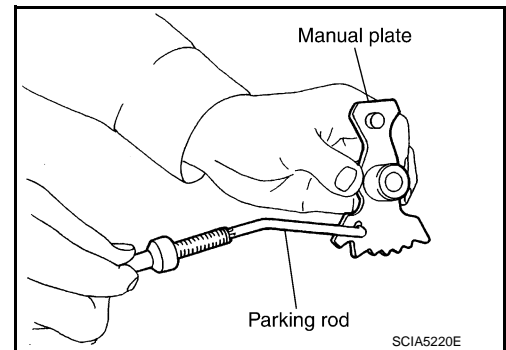

5. Install manual plate (with parking rod) to manual shaft.

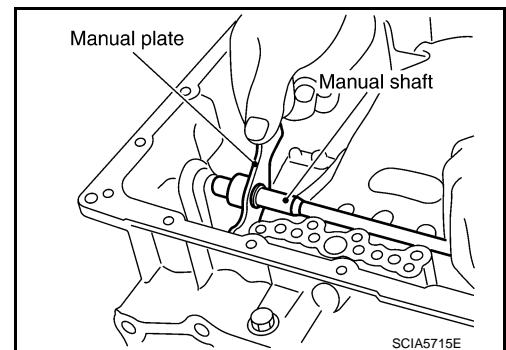

6. Install retaining pin into the manual plate and manual shaft.
 - a. Fit pinhole of the manual plate to pinhole of the manual shaft with a pin punch.
 - b. Use a hammer to tap the retaining pin into the manual plate.
CAUTION:
Drive retaining pin to 2 ± 0.5 mm (0.08 ± 0.020 in) over the manual plate.

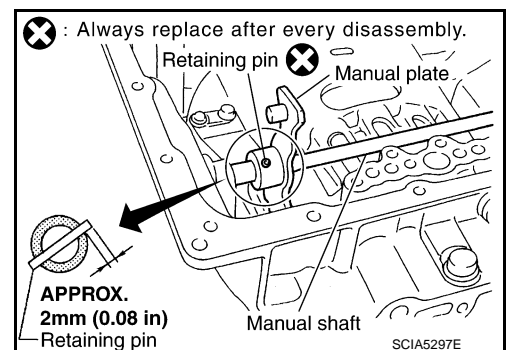

TRANSMISSION ASSEMBLY

< UNIT DISASSEMBLY AND ASSEMBLY >

[5AT: RE5R05A]

7. Install retaining pin into the transmission case and manual shaft.
 - a. Fit pinhole of the transmission case to pinhole of the manual shaft with a pin punch.
 - b. Use a hammer to tap the retaining pin into the transmission case.

CAUTION:

Drive retaining pin to 5 ± 1 mm (0.20 \pm 0.04 in) over the transmission case.

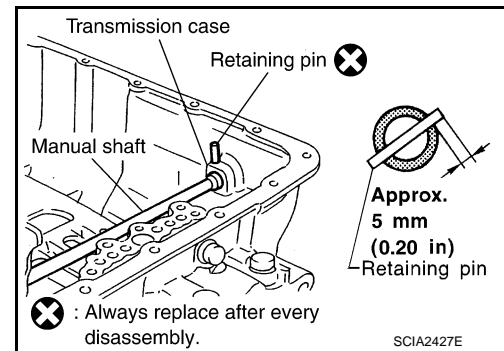

8. Install O-rings to servo assembly.

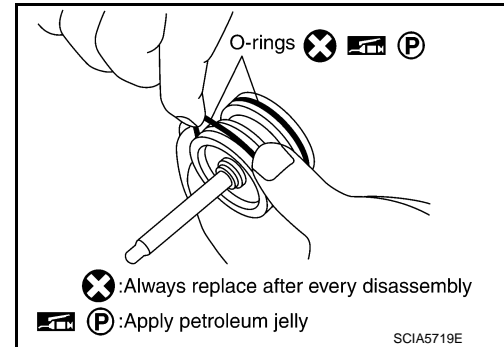

9. Install return spring to servo assembly.

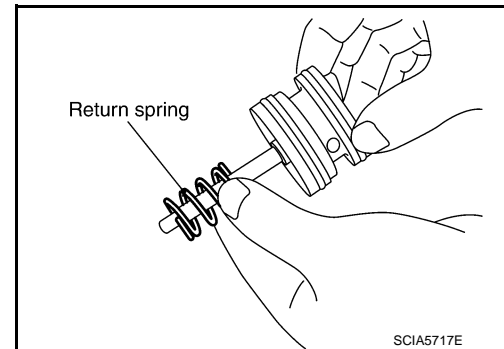

10. Install servo assembly to transmission case.

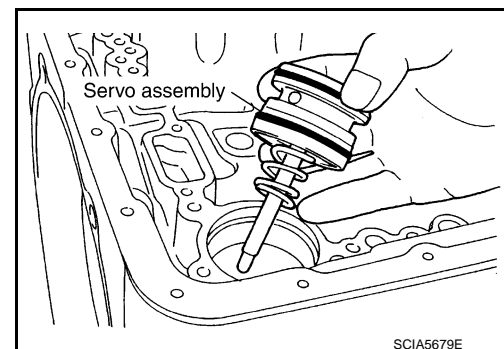

11. Install snap ring to transmission case with a pair of snap ring pliers.

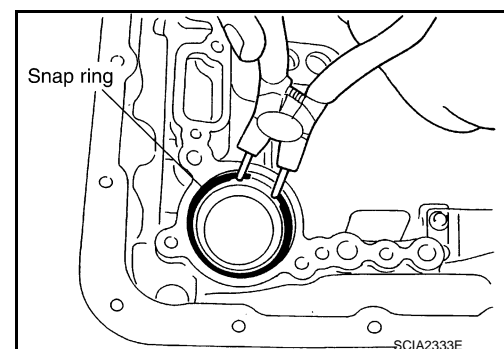

A
B
C
TM
E
F
G
H
I
J
K
L
M
N
O
P

TRANSMISSION ASSEMBLY

< UNIT DISASSEMBLY AND ASSEMBLY >

[5AT: RE5R05A]

12. Install D-rings to reverse brake piston.

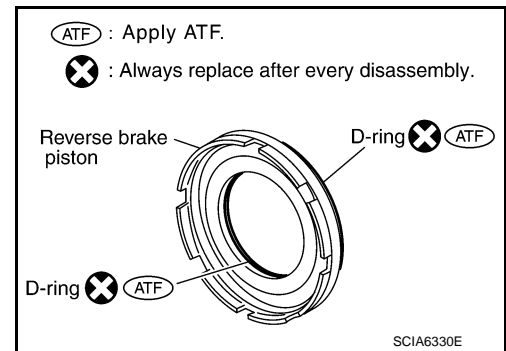

13. Install reverse brake piston to transmission case.

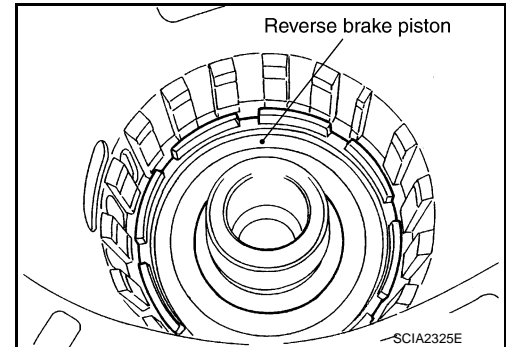

14. Install needle bearing to drum support edge surface.

CAUTION:

Check the direction of needle bearing. Refer to [TM-210](#), "[Location of Adjusting Shims, Needle Bearings, Thrust Washers and Snap Rings](#)".

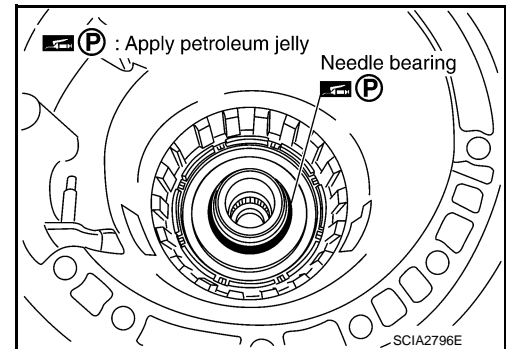

15. Install seal rings to drum support.

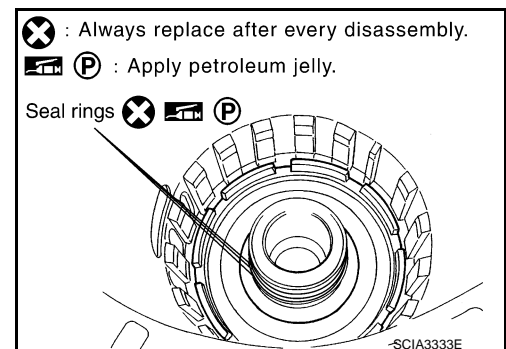

16. Install spring retainer and return spring to transmission case.

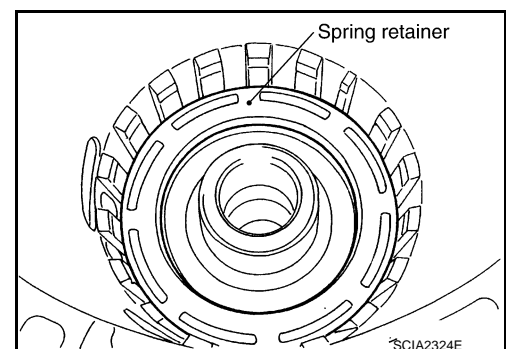

TRANSMISSION ASSEMBLY

< UNIT DISASSEMBLY AND ASSEMBLY >

[5AT: RE5R05A]

17. Set the SST on spring retainer and install snap ring (fixing spring retainer) to transmission case while compressing return spring.

CAUTION:

Securely assemble them with a flat-bladed screwdriver so that snap ring tension is slightly weak.

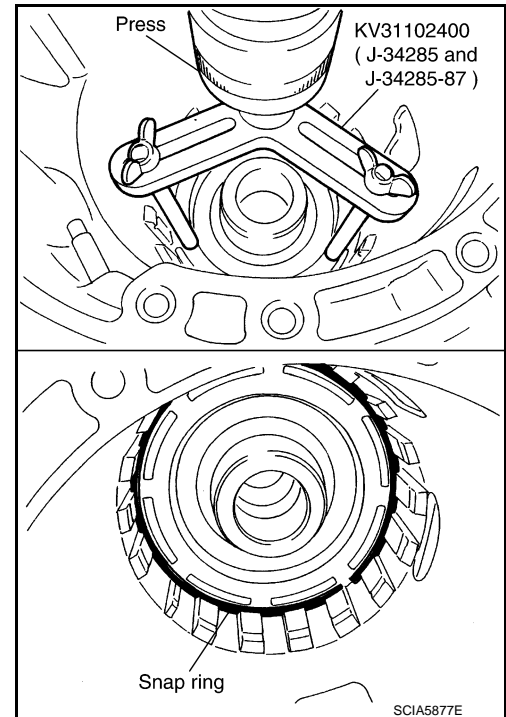

18. Install reverse brake drive plates, driven plates, dish plates, retaining plate and snap ring to transmission case.

- 1 : Snap ring
- 2 : Retaining plate
- 3 : Drive plate
- 4 : Driven plate
- 5 : Dish plate
- 6/6 : Drive plate / Driven plate

CAUTION:

Check order of plates.

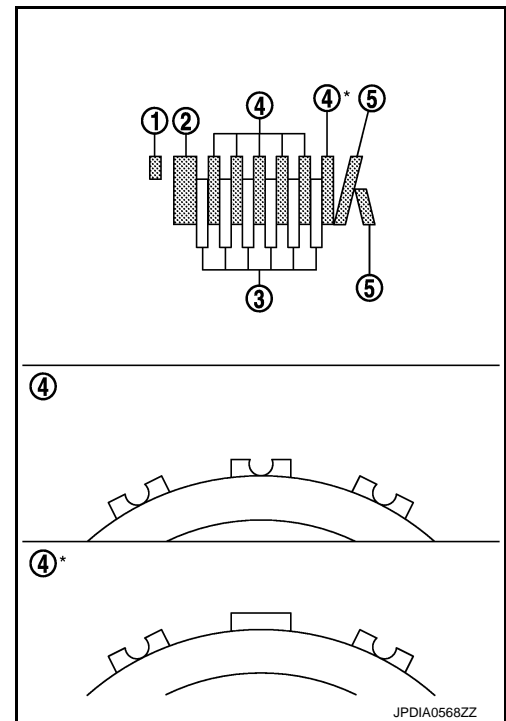

A
B
C
TM
E
F
G
H
I
J
K
L
M
N
O
P

TRANSMISSION ASSEMBLY

< UNIT DISASSEMBLY AND ASSEMBLY >

[5AT: RE5R05A]

19. Assemble N-spring.
20. Install reverse brake retaining plate to transmission case.

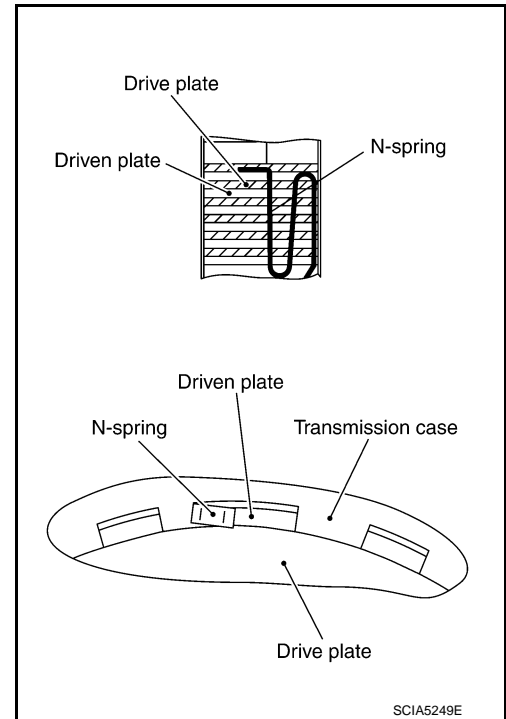

21. Install snap ring to transmission case.

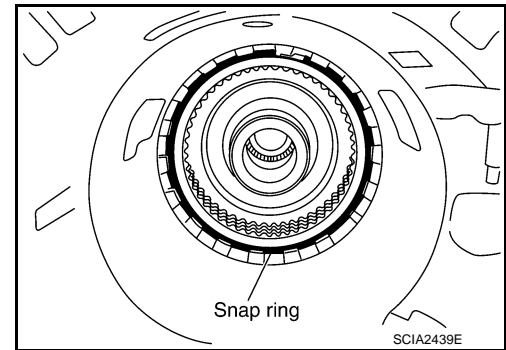

22. Measure clearance between retaining plate and snap ring. If not within specified clearance, select proper retaining plate.

Specified clearance "A"

Standard: [TM-273, "Reverse Brake"](#).

Retaining plate: Refer to [TM-273, "Reverse Brake"](#)

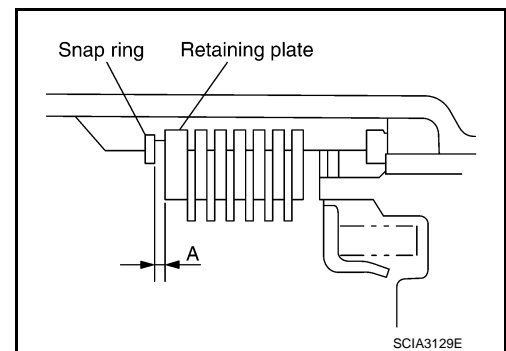

23. Install needle bearing to transmission case.

CAUTION:

Check the direction of needle bearing. Refer to [TM-210, "Location of Adjusting Shims, Needle Bearings, Thrust Washers and Snap Rings"](#).

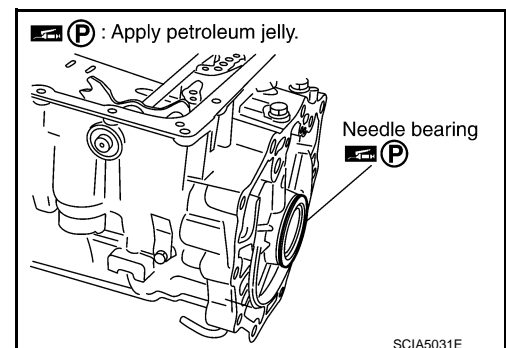

TRANSMISSION ASSEMBLY

< UNIT DISASSEMBLY AND ASSEMBLY >

[5AT: RE5R05A]

24. Install output speed sensor (1) to transmission case. Tighten bolt (⬅) to the specified torque.

CAUTION:

- Never subject it to impact by dropping or hitting it.
- Never disassemble.
- Never allow metal filings, etc. to get on the sensor's front edge magnetic area.
- Never place in an area affected by magnetism.

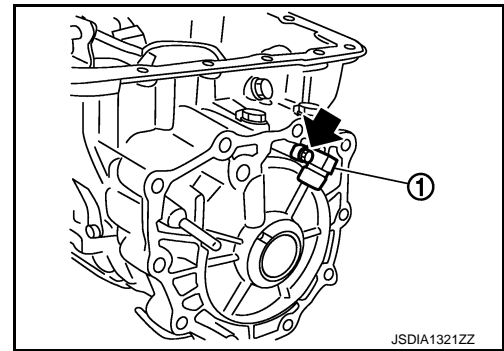

25. As shown in the figure, use the drift to drive rear oil seal into the rear extension (2WD) or adapter case (AWD) until it is flush.

CAUTION:

- Never reuse rear oil seal.
- Apply ATF to rear oil seal.

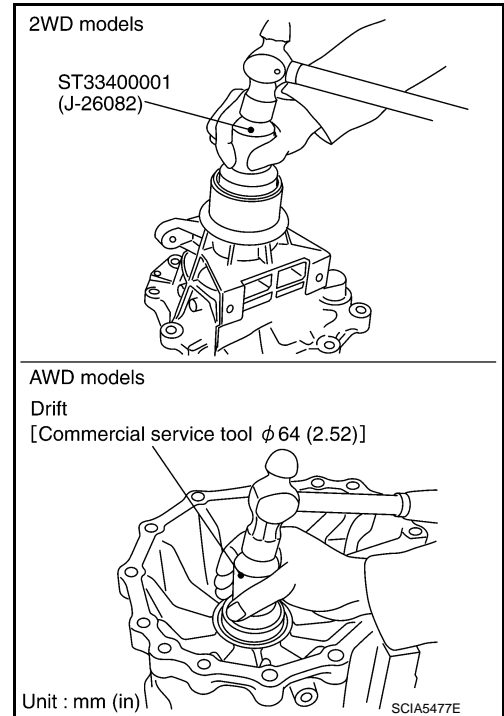

26. Install return spring (1) to parking pawl (2).

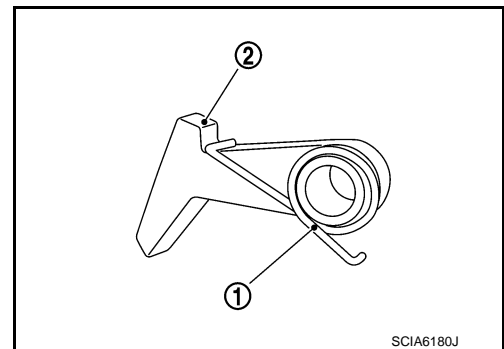

27. Install parking pawl (with return spring) and pawl shaft to rear extension (2WD) or adapter case (AWD).

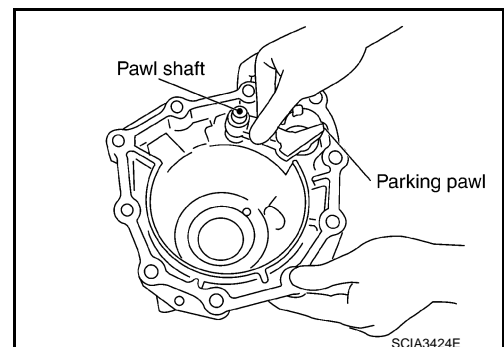

A

B

C

TM

E

F

G

H

I

J

K

L

M

N

O

P

TRANSMISSION ASSEMBLY

< UNIT DISASSEMBLY AND ASSEMBLY >

[5AT: RE5R05A]

28. Install parking actuator support to rear extension (2WD) or adapter case (AWD).

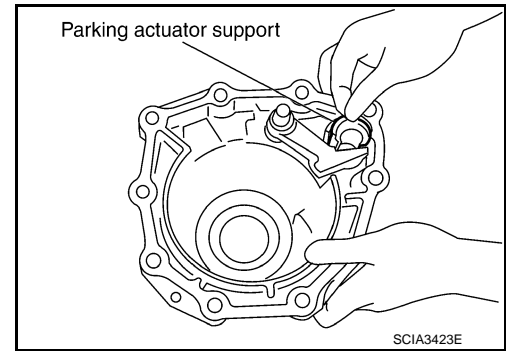

29. Install needle bearing (1) to rear extension (2WD) or adapter case (AWD).

CAUTION:

Check the direction of needle bearing. Refer to [TM-210](#), "[Location of Adjusting Shims, Needle Bearings, Thrust Washers and Snap Rings](#)".

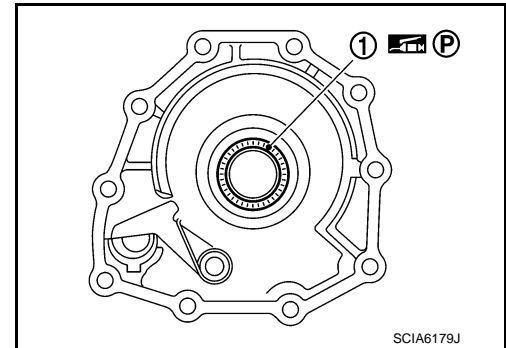

30. Install rear extension assembly (2WD) or adapter case assembly (AWD) according to the following procedures.

a. **2WD**

- i. Install seal rings (1) to output shaft.

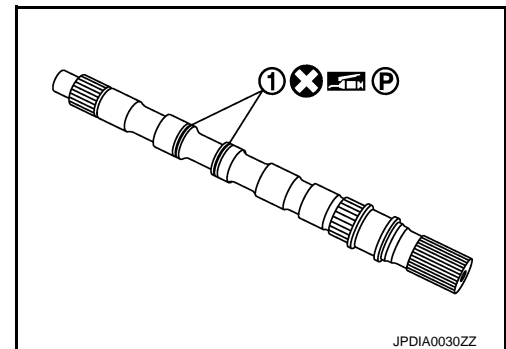

- ii. Install parking gear (1) to output shaft (2).

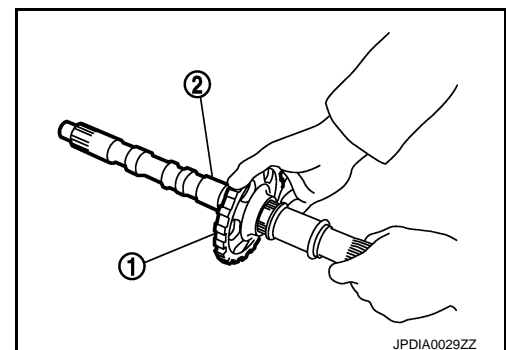

TRANSMISSION ASSEMBLY

< UNIT DISASSEMBLY AND ASSEMBLY >

[5AT: RE5R05A]

- iii. Install output shaft to transmission case.

CAUTION:

Be careful not to mistake front for rear because both sides looks similar. (Thinner end is front side.)

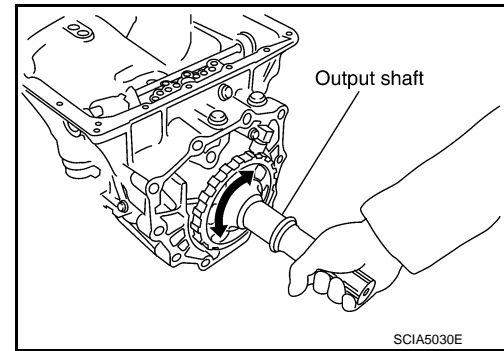

- iv. Install bearing race to output shaft.

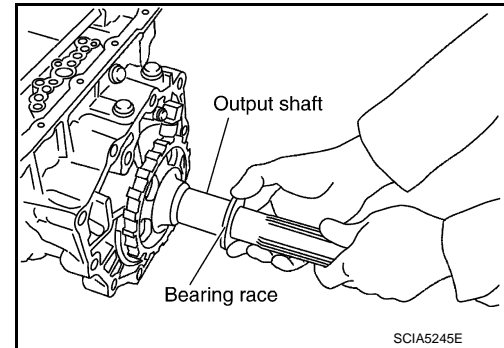

- v. Apply recommended sealant (Genuine Anaerobic Liquid Gasket or equivalent. Refer to [GI-17. "Recommended Chemical Products and Sealants."](#)) to rear extension assembly as shown in the figure.

- A** : Start and finish point shall be in the center of two bolts.
- B** : 3 – 5 mm (0.12 – 0.20 in)
- Sealant width (C)** : 1.0 – 2.0 mm (0.04 – 0.08 in)
- Sealant height (C)** : 0.4 – 1.0 mm (0.016 – 0.04 in)

CAUTION:

Completely remove all moisture, oil and old sealant, etc. from the transmission case and rear extension assembly mounting surfaces.

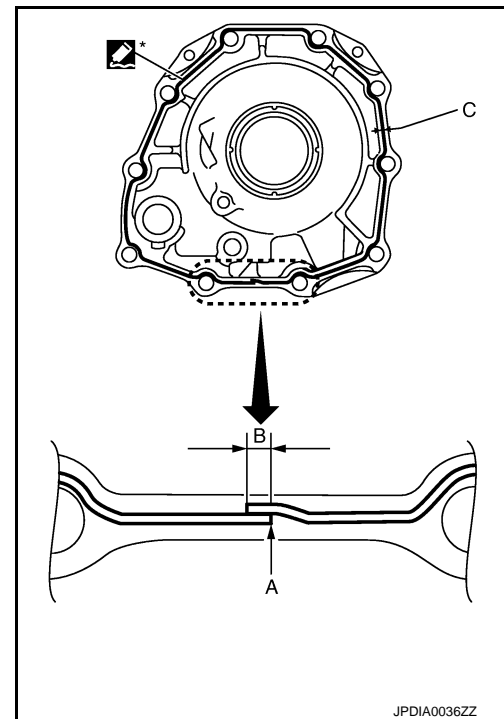

- vi. Install rear extension assembly to transmission case.

CAUTION:

Insert the tip of parking rod between the parking pawl and the parking actuator support when assembling the rear extension assembly.

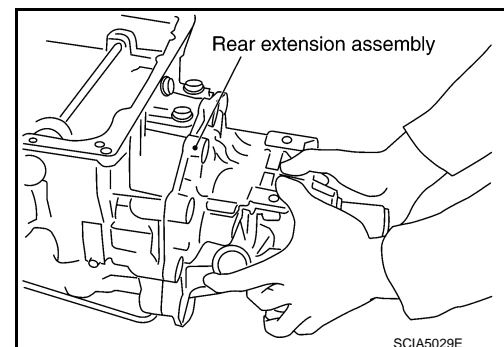

A
B
C
TM
E
F
G
H
I
J
K
L
M
N
O
P

TRANSMISSION ASSEMBLY

< UNIT DISASSEMBLY AND ASSEMBLY >

[5AT: RE5R05A]

vii. Tighten rear extension assembly bolts to the specified torque.

1 : Self-sealing bolt

A : Bolt

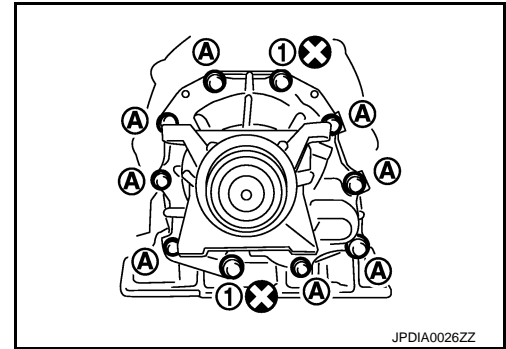

b. **AWD**

i. Install seal rings (1) to output shaft.

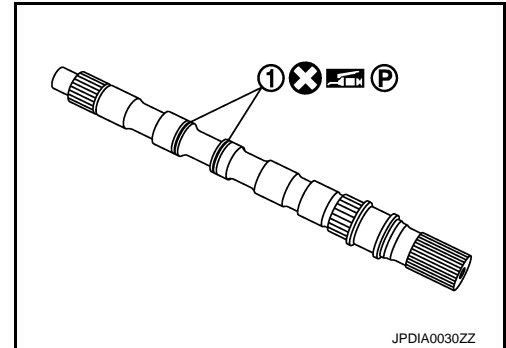

ii. Install parking gear (1) to output shaft (2).

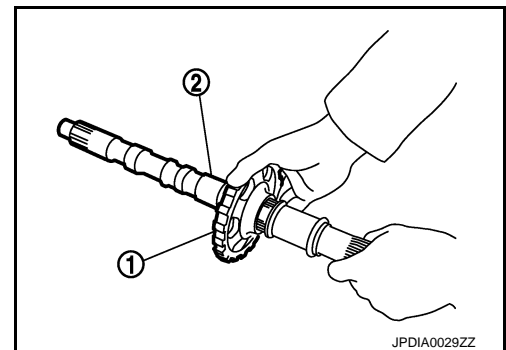

iii. Install output shaft in transmission case.

CAUTION:

Be careful not to mistake front for rear because both sides looks similar. (Thinner end is front side.)

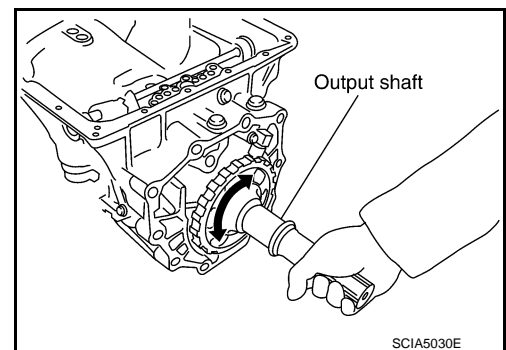

TRANSMISSION ASSEMBLY

< UNIT DISASSEMBLY AND ASSEMBLY >

[5AT: RE5R05A]

iv. Install bearing race to output shaft.

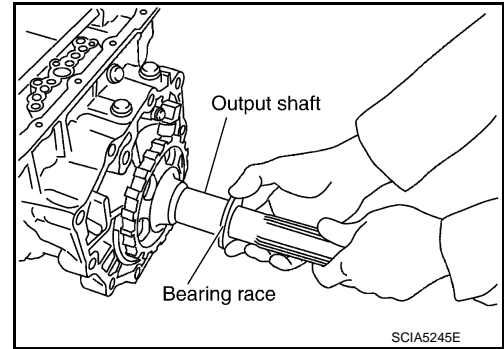

v. Install gasket onto transmission case.

CAUTION:

- Completely remove all moisture, oil and old gasket, etc. from the transmission case and adapter case assembly mounting surfaces.
- Never reuse gasket.

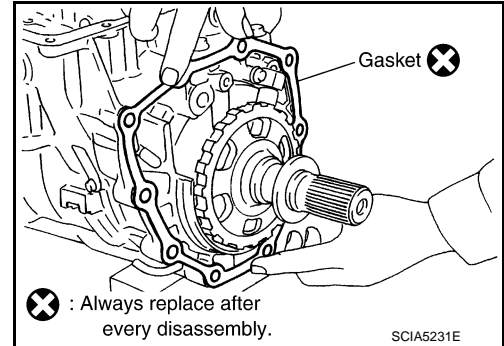

⊗ : Always replace after every disassembly.

vi. Install adapter case assembly to transmission case.

CAUTION:

Insert the tip of parking rod between the parking pawl and the parking actuator support when assembling the adapter case assembly.

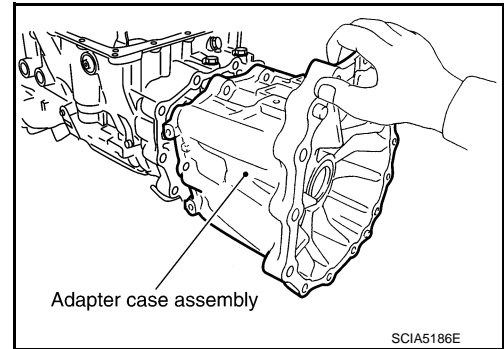

vii. Tighten adapter case assembly bolts (1) to the specified torque. [With bracket (2).]

3 : Self-sealing bolt

← : Bolt

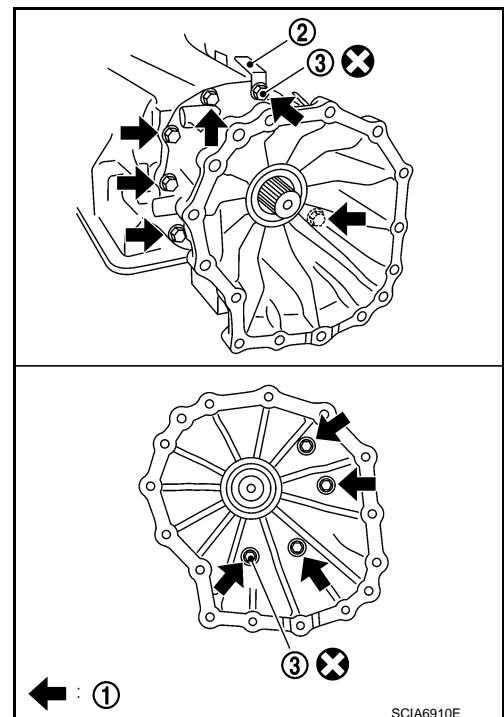

← : ①

SCIA6910E

A
B
C
TM
E
F
G
H
I
J
K
L
M
N
O
P

TRANSMISSION ASSEMBLY

< UNIT DISASSEMBLY AND ASSEMBLY >

[5AT: RE5R05A]

31. Install needle bearing in drum support.

CAUTION:

Check the direction of needle bearing. Refer to [TM-210](#), "[Location of Adjusting Shims, Needle Bearings, Thrust Washers and Snap Rings](#)".

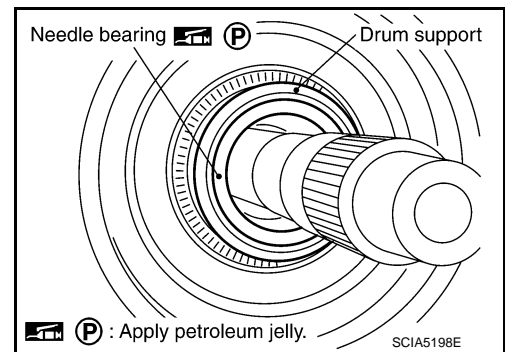

32. Install direct clutch assembly in reverse brake.

CAUTION:

Make sure that drum support edge surface and direct clutch inner boss edge surface come to almost same place.

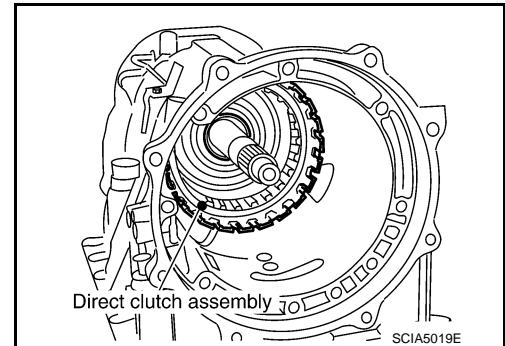

33. Install high and low reverse clutch assembly in direct clutch.

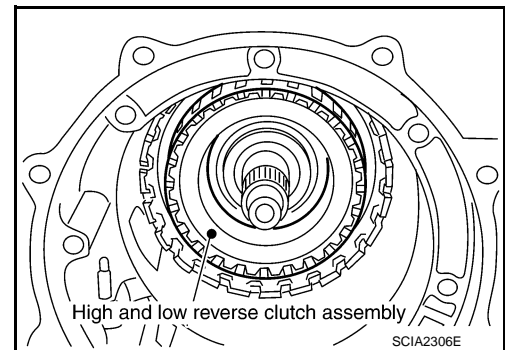

34. Align the drive plate with a flat-bladed screwdriver.

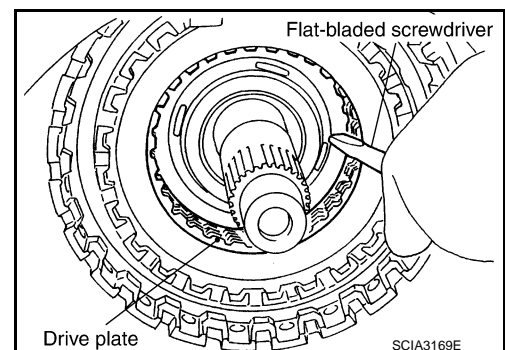

35. Install high and low reverse clutch hub, mid sun gear assembly and rear sun gear assembly as a unit.

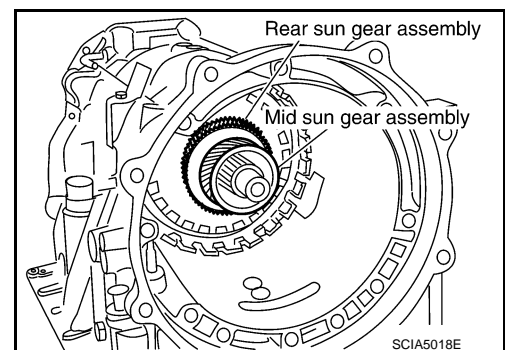

TRANSMISSION ASSEMBLY

< UNIT DISASSEMBLY AND ASSEMBLY >

[5AT: RE5R05A]

CAUTION:

Make sure that portion "A" of high and low reverse clutch drum protrudes approximately 2 mm (0.08 in) beyond portion "B" of rear sun gear.

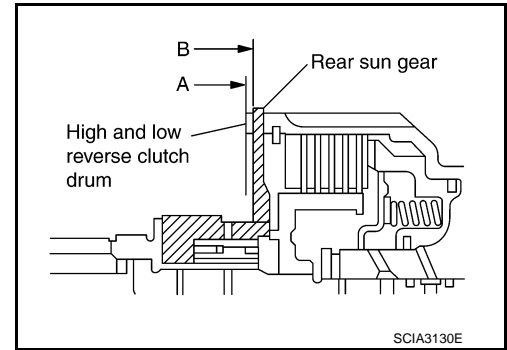

36. Install needle bearing to rear carrier assembly.

CAUTION:

Check the direction of needle bearing. Refer to [TM-210, "Location of Adjusting Shims, Needle Bearings, Thrust Washers and Snap Rings"](#).

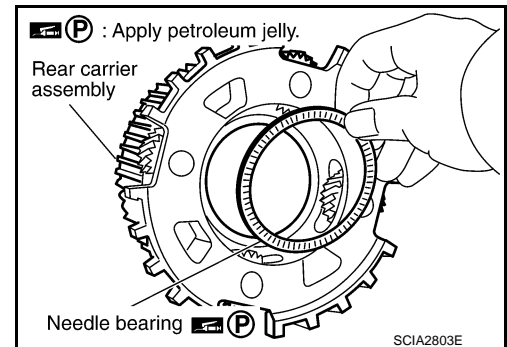

37. Install bearing race to rear carrier assembly.

CAUTION:

Check the direction of needle bearing. Refer to [TM-210, "Location of Adjusting Shims, Needle Bearings, Thrust Washers and Snap Rings"](#).

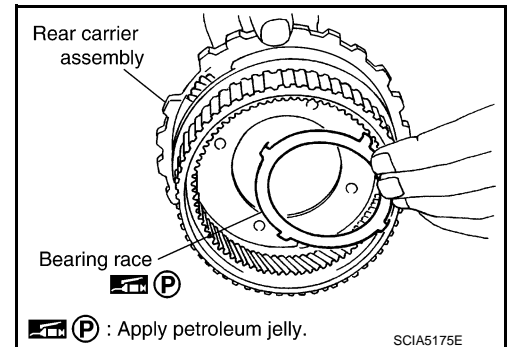

38. Install rear carrier assembly to direct clutch drum.

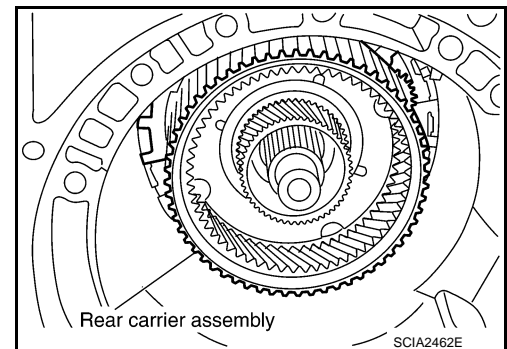

A
B
C
TM
E
F
G
H
I
J
K
L
M
N
O
P

TRANSMISSION ASSEMBLY

< UNIT DISASSEMBLY AND ASSEMBLY >

[5AT: RE5R05A]

39. Install needle bearing (rear side) to mid carrier assembly.

CAUTION:

Check the direction of needle bearing. Refer to [TM-210](#), "[Location of Adjusting Shims, Needle Bearings, Thrust Washers and Snap Rings](#)".

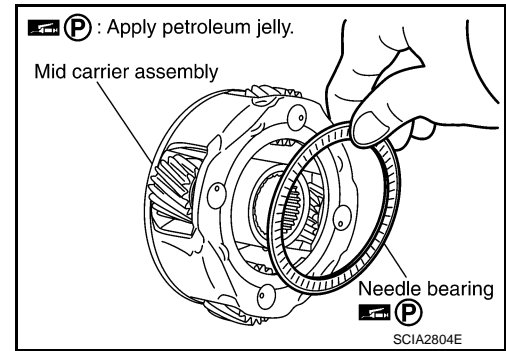

40. Install needle bearing (front side) to mid carrier assembly.

CAUTION:

Check the direction of needle bearing. Refer to [TM-210](#), "[Location of Adjusting Shims, Needle Bearings, Thrust Washers and Snap Rings](#)".

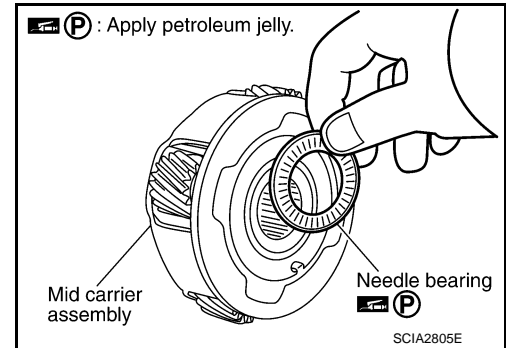

41. Install mid carrier assembly to rear carrier assembly.

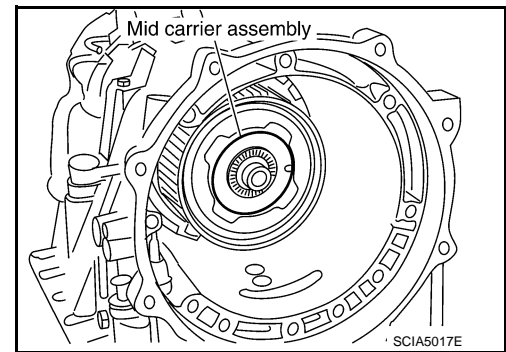

42. Install front carrier assembly, input clutch assembly and rear internal gear as a unit.

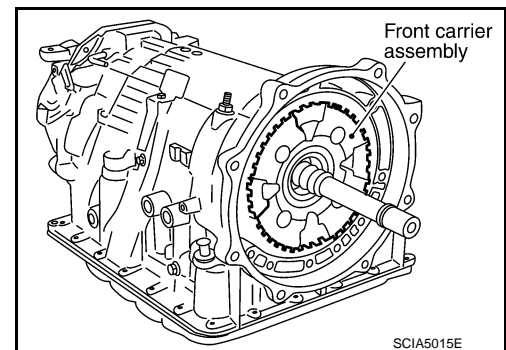

43. Install seal rings to input clutch assembly.

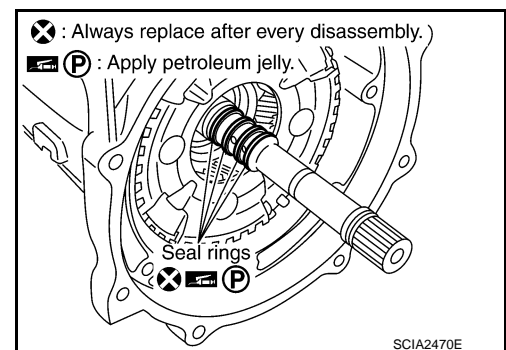

TRANSMISSION ASSEMBLY

< UNIT DISASSEMBLY AND ASSEMBLY >

[5AT: RE5R05A]

44. Install band servo anchor end pin and lock nut to transmission case.

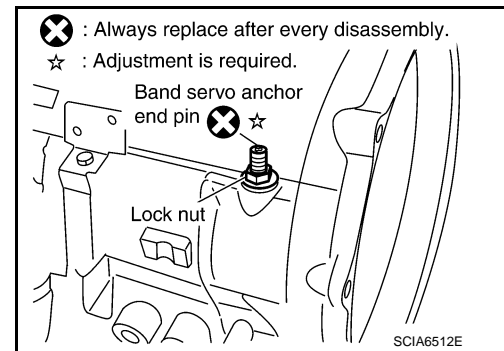

45. Install brake band to transmission case.

CAUTION:

Assemble it so that identification to avoid incorrect installation faces servo side.

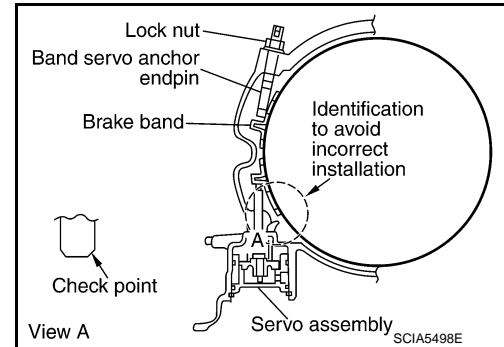

46. Install front sun gear assembly to front carrier assembly.

CAUTION:

Apply ATF to front sun gear bearing and 3rd one-way clutch end bearing.

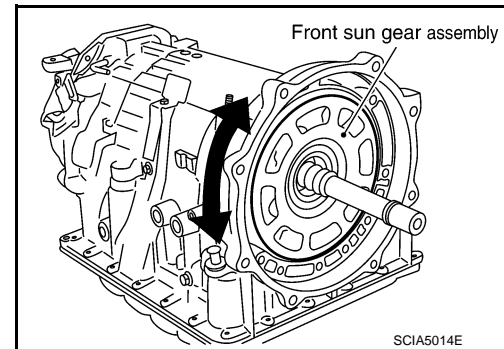

47. Install needle bearing to front sun gear.

CAUTION:

Check the direction of needle bearing. Refer to [TM-210, "Location of Adjusting Shims, Needle Bearings, Thrust Washers and Snap Rings"](#).

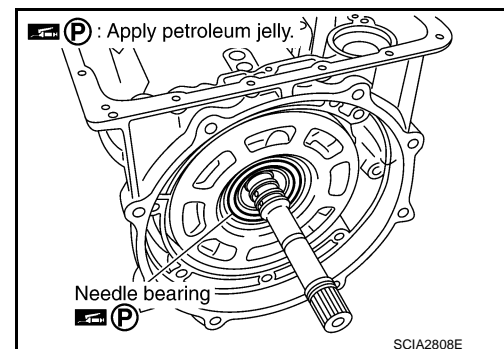

48. Adjust brake band tilting using a clip so that brake band contacts front sun gear drum evenly.

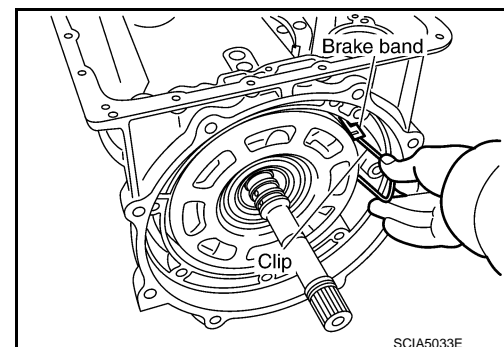

A
B
C
TM
E
F
G
H
I
J
K
L
M
N
O
P

TRANSMISSION ASSEMBLY

< UNIT DISASSEMBLY AND ASSEMBLY >

[5AT: RE5R05A]

49. Adjust brake band.
 - a. Loosen lock nut.
 - b. Tighten band servo anchor end pin to specified torque.

 : 5.0 N·m (0.51 kg-m, 44 in-lb)

- c. Back of band servo anchor end pin three turns.
 - d. Holding band servo anchor end pin, tighten lock nut to the specified torque.

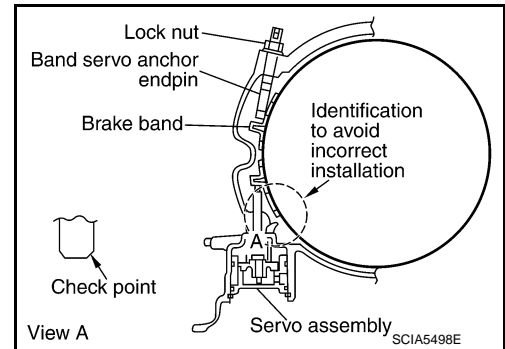

50. Adjustment of total end play.
 - Measure clearance between front sun gear and bearing race for oil pump cover.
 - Select proper thickness of bearing race so that end play is within specifications.

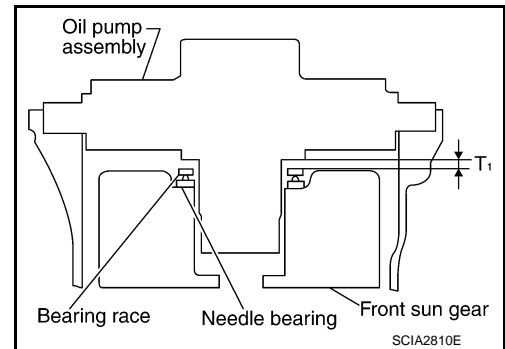

- a. Measure dimensions "K" and "L" and then calculate dimension "J".

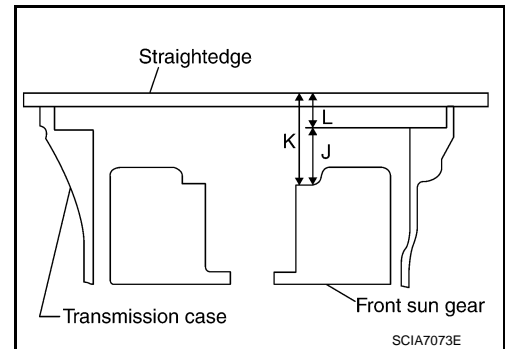

- i. Measure dimension "K".

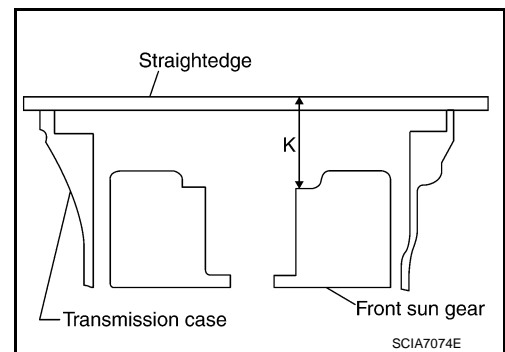

TRANSMISSION ASSEMBLY

< UNIT DISASSEMBLY AND ASSEMBLY >

[5AT: RE5R05A]

- ii. Measure dimension "L".
- iii. Calculate dimension "J".

"J" : Distance between oil pump fitting surface of transmission case and needle bearing mating surface of front sun gear.

$$J = K - L$$

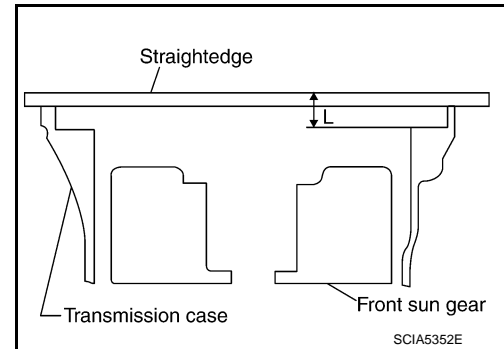

- b. Measure dimensions "M1" and "M2" and then calculate dimension "M".

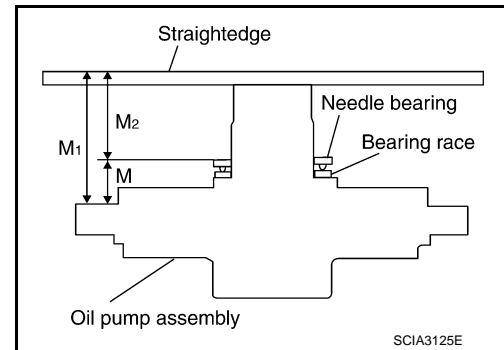

- i. Place bearing race and needle bearing on oil pump assembly.

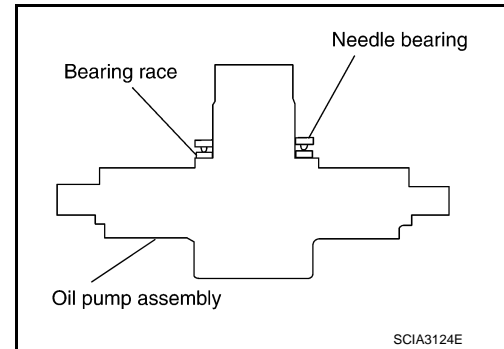

- ii. Measure dimension "M1".

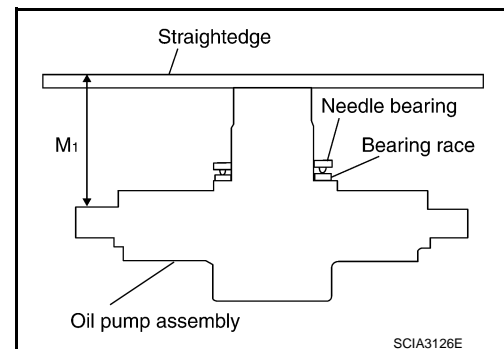

- iii. Measure dimension "M2".

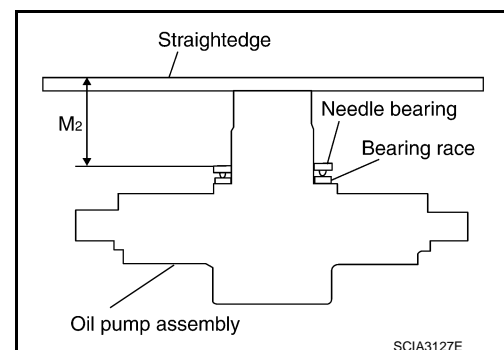

A
B
C
TM
E
F
G
H
I
J
K
L
M
N
O
P

TRANSMISSION ASSEMBLY

< UNIT DISASSEMBLY AND ASSEMBLY >

[5AT: RE5R05A]

iv. Calculate dimension "M".

"M" : Distance between transmission case fitting surface of oil pump and needle bearing on oil pump.

$$M = M_1 - M_2$$

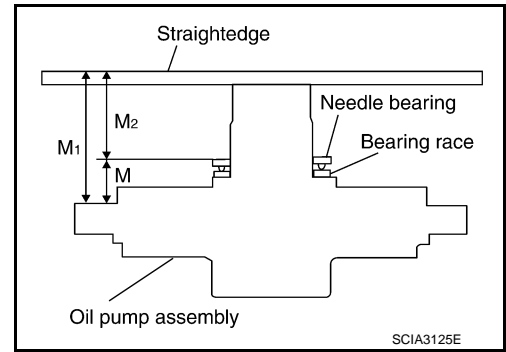

c. Adjust total end play "T₁".

$$T_1 = J - M$$

Total end play "T₁" : Refer to [TM-273, "Total End Play"](#).

- Select proper thickness of bearing race so that total end play is within specifications.

Bearing races : Refer to [TM-273, "Total End Play"](#).

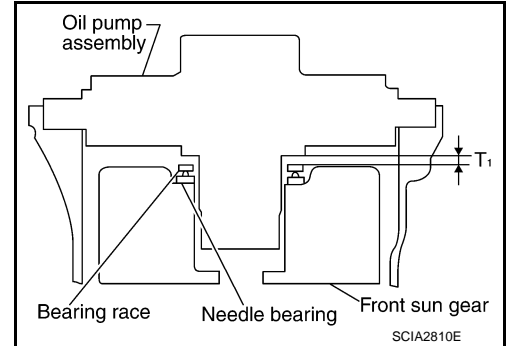

51. Install O-ring to oil pump assembly.

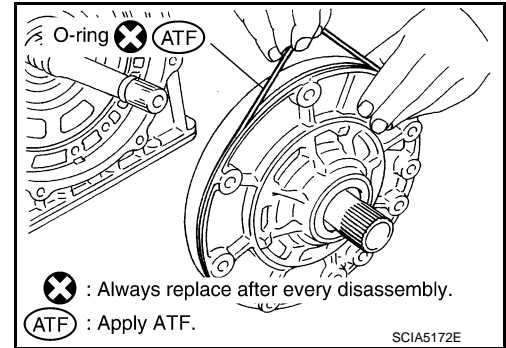

52. Install bearing race to oil pump assembly.

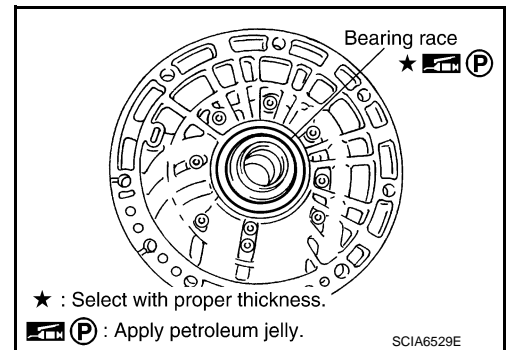

53. Install oil pump assembly to transmission case.

CAUTION:
Apply ATF to oil pump bearing.

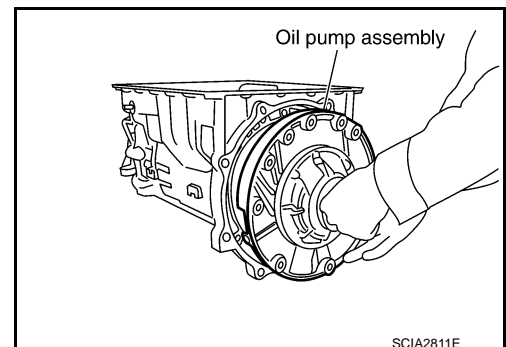

TRANSMISSION ASSEMBLY

< UNIT DISASSEMBLY AND ASSEMBLY >

[5AT: RE5R05A]

54. Apply recommended sealant (Genuine RTV Silicone Sealant or equivalent. Refer to [GI-17, "Recommended Chemical Products and Sealants"](#).) to oil pump assembly as shown in the figure.

CAUTION:

Completely remove all moisture, oil and old sealant, etc. from the oil pump mounting bolts and oil pump mounting bolt mounting surfaces.

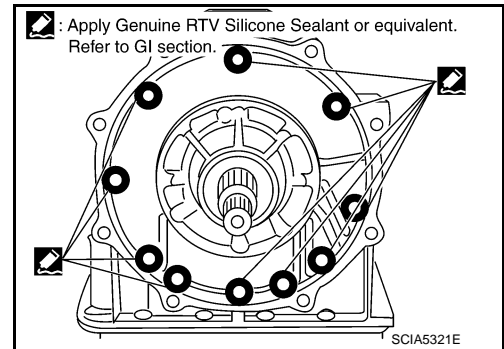

55. Tighten oil pump bolts to the specified torque.

CAUTION:

Apply ATF to oil pump bushing.

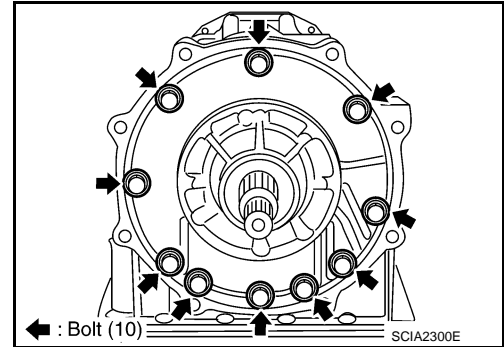

56. Install O-ring to input clutch assembly.

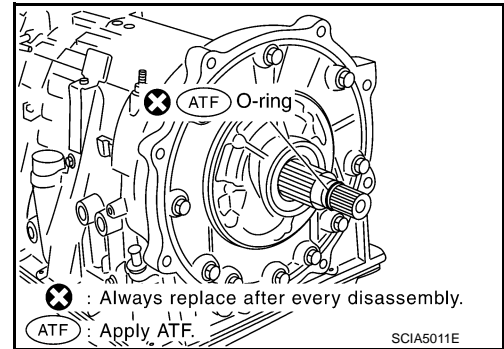

57. Install converter housing to transmission case, and then tighten converter housing bolts (A) and self-sealing bolt (B) to the specified torque.

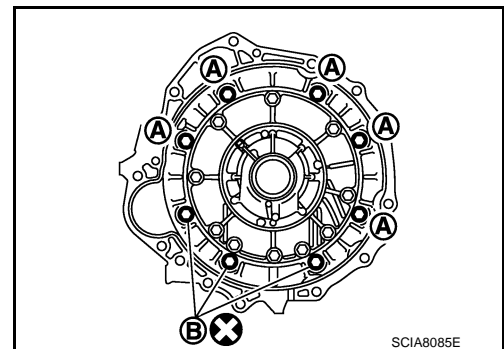

58. Make sure that brake band (A) does not close input speed sensor holes (B).

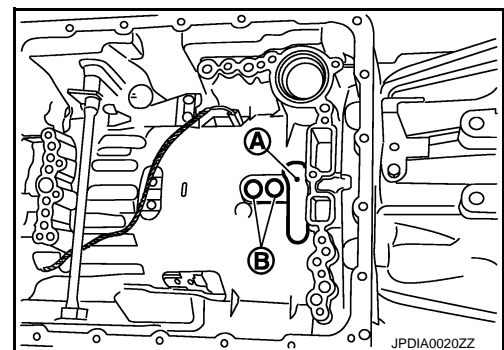

A
B
C
TM
E
F
G
H
I
J
K
L
M
N
O
P

TRANSMISSION ASSEMBLY

< UNIT DISASSEMBLY AND ASSEMBLY >

[5AT: RE5R05A]

59. Connect TCM connector (A) and transmission range switch connector (B).

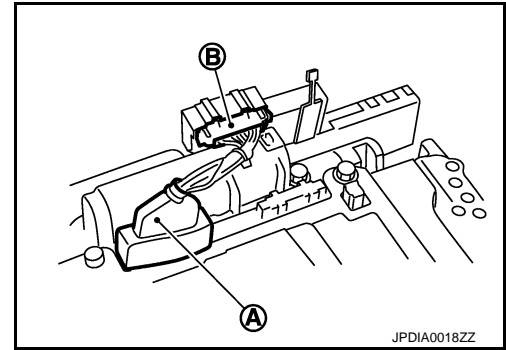

60. Install A/T assembly connector (A) to control valve with TCM.

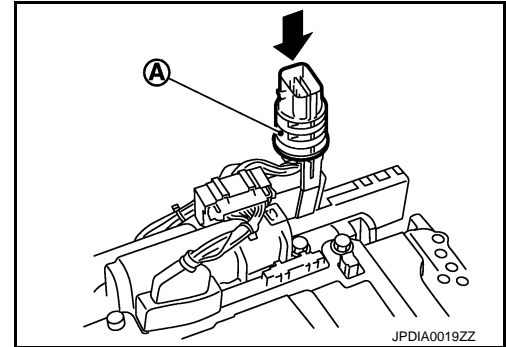

61. Connect TCM connectors (A) and (B).

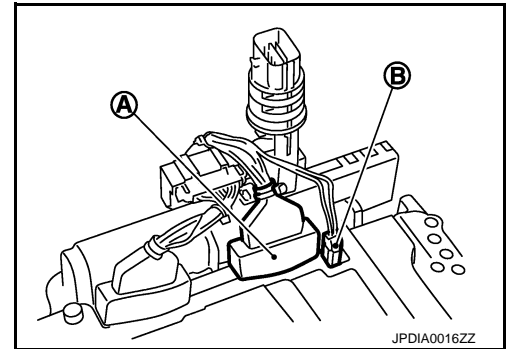

62. Install O-ring (1) to A/T assembly connector (A).

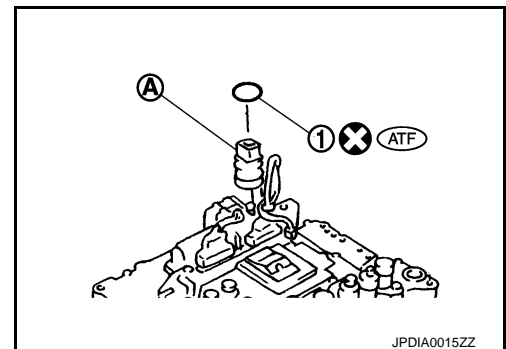

63. Install bracket (1) to A/T fluid temperature sensor 2 (2).

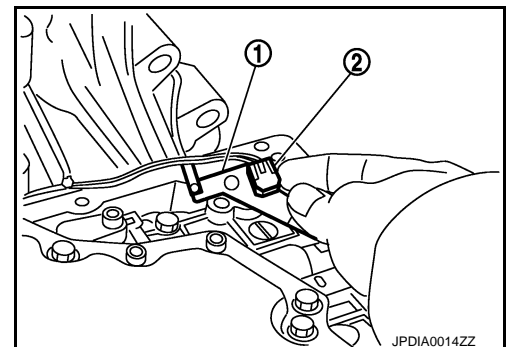

TRANSMISSION ASSEMBLY

< UNIT DISASSEMBLY AND ASSEMBLY >

[5AT: RE5R05A]

64. Install A/T fluid temperature sensor 2 (1) [with bracket (2)] to control valve with TCM. Tighten A/T fluid temperature sensor 2 bolt to the specified torque.

CAUTION:

Adjust bolt hole of bracket to bolt hole of control valve.

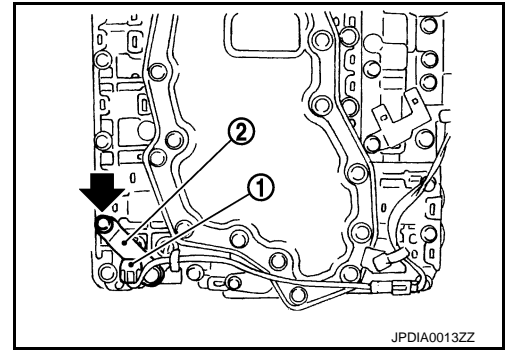

65. Install control valve with TCM to transmission case.

CAUTION:

- Make sure that input speed sensor securely installs input speed sensor holes (B).

A : Brake band

- Hang down output speed sensor harness toward outside so as not to disturb installation of control valve with TCM.
- Adjust A/T assembly harness connector of control valve with TCM to terminal hole of transmission case.

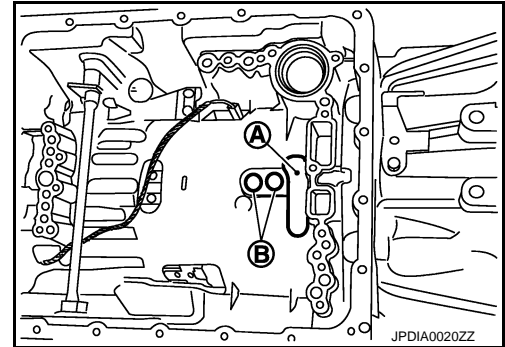

- Assemble it so that manual valve cutout is engaged with manual plate projection.

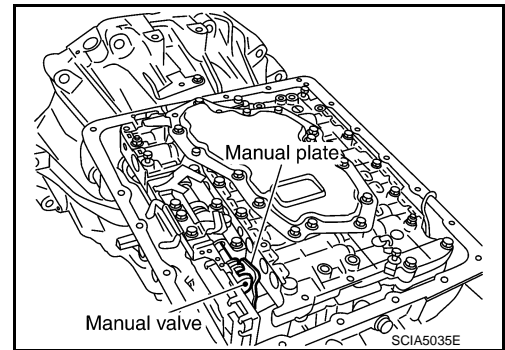

66. Install bolts (A), (B) and (C) in control valve with TCM. Tighten bolt 1, 2 and 3 temporarily to prevent dislocation. After that tighten them in order (1 → 2 → 3), and then tighten other bolts. Tighten control valve with TCM bolts to the specified torque.

↩ : Front

Bolt symbol	A	B	C
Number of bolts	5	6	1
Length mm (in)	42 (1.65)	55 (2.17)	40 (1.57)
Tightening torque N·m (km-g, in-lb)	7.9 (0.81, 70)		With ATF applied 7.9 (0.81, 70)

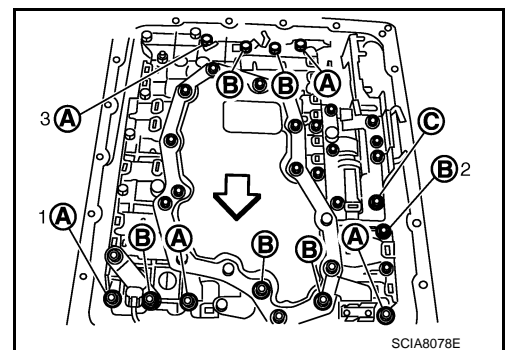

A
B
C
TM
E
F
G
H
I
J
K
L
M
N
O
P

TRANSMISSION ASSEMBLY

< UNIT DISASSEMBLY AND ASSEMBLY >

[5AT: RE5R05A]

- 67. Connect A/T fluid temperature sensor 2 connector (A).
- 68. Engage terminal cord assembly and A/T fluid temperature sensor 2 harness with terminal clips (←).

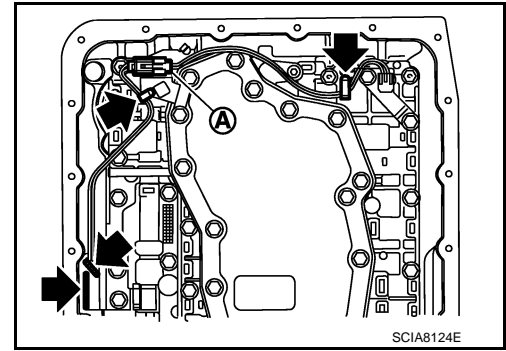

- 69. Connect output speed sensor connector (A).
- 70. Engage output speed sensor harness with terminal clip (←).

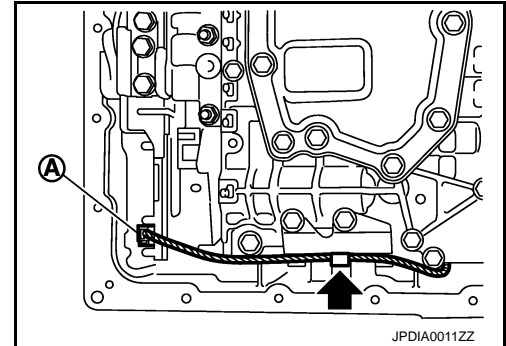

- 71. Pull down A/T assembly connector.
CAUTION:
Be careful not to damage connector.

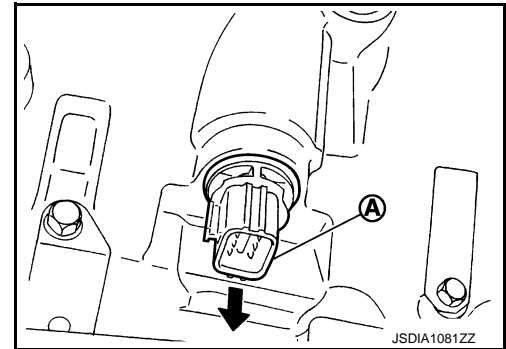

- 72. Install snap ring to A/T assembly connector.

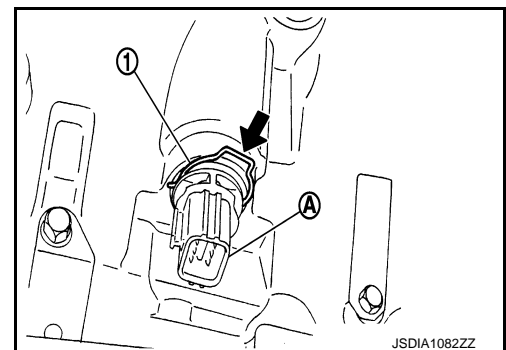

- 73. Install magnets (1) to oil pan.

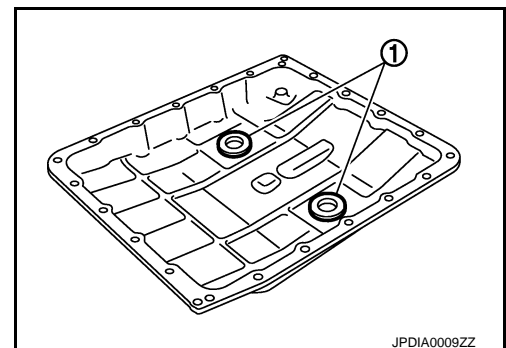

TRANSMISSION ASSEMBLY

< UNIT DISASSEMBLY AND ASSEMBLY >

[5AT: RE5R05A]

74. Install oil pan gasket to transmission case.

CAUTION:

- Do not reuse oil pan gasket.
- Install it in the direction to align hole positions.
- Completely remove all moisture, oil and old gasket, etc. from oil pan gasket mounting surface.

75. Install oil pan (2) and clips (1) to transmission case.

⇐ : Front

➡ : Oil pan mounting bolt

CAUTION:

- Install it so that drain plug comes to the position as shown in the figure.
- Be careful not to pinch harnesses.
- Completely remove all moisture, oil and old gasket, etc. from oil pan mounting surface.

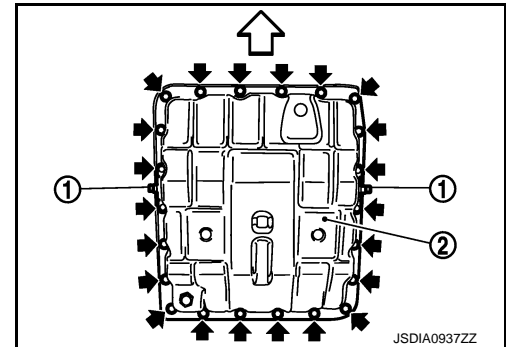

76. Tighten oil pan mounting bolts to the specified torque in numerical order shown in the figure after temporarily tightening them. Tighten oil pan mounting bolts to the specified torque.

⇐ : Front

CAUTION:

Never reuse oil pan mounting bolts.

77. Install drain plug to oil pan. Tighten drain plug to the specified torque.

CAUTION:

Never reuse drain plug gasket.

78. Pour ATF into torque converter.

- Approximately 2 liter (2-1/8 US qt, 1-3/4 Imp qt) of ATF is required for a new torque converter.
- When reusing old torque converter, add the same amount of ATF as was drained.

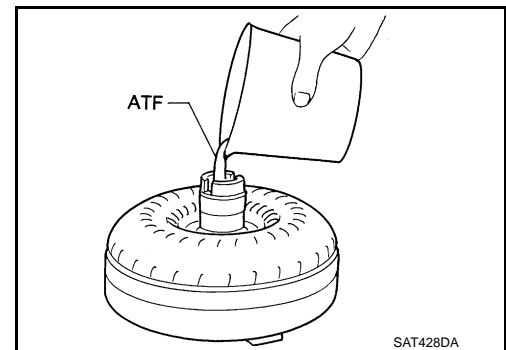
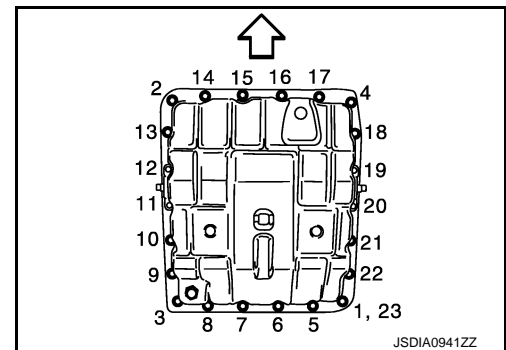

79. Install torque converter while aligning notches of torque converter with notches of oil pump.

CAUTION:

Install torque converter while rotating it.

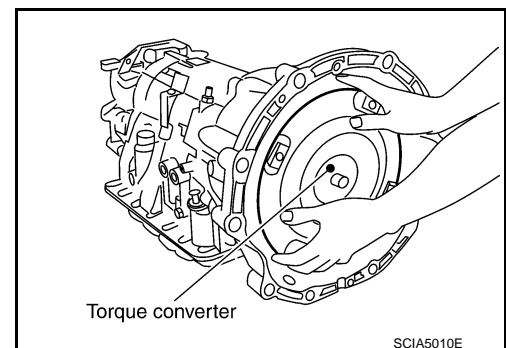

A
B
C
TM
E
F
G
H
I
J
K
L
M
N
O
P

TRANSMISSION ASSEMBLY

< UNIT DISASSEMBLY AND ASSEMBLY >

[5AT: RE5R05A]

80. Measure dimension (A) to make sure that torque converter is in proper position.

- B : Scale
- C : Straightedge

Dimension (A) : Refer to [TM-273, "Torque Converter"](#).

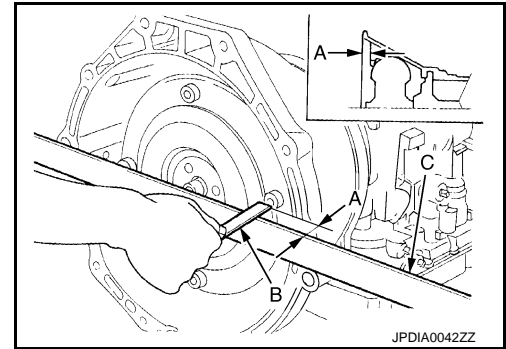

Inspection

INFOID:000000004343055

INSPECTION AFTER REMOVAL

- Check foreign materials in oil pan to help determine causes of malfunction. If the ATF is very dark, smells burned, or contains foreign particles, the frictional material (clutches, band) may need replacement. A tacky film that will not wipe clean indicates varnish build up. Varnish can cause valves, servo, and clutches to stick and can inhibit pump pressure.
- **If frictional material is detected, perform A/T fluid cooler cleaning. Refer to [TM-145, "Cleaning"](#).**

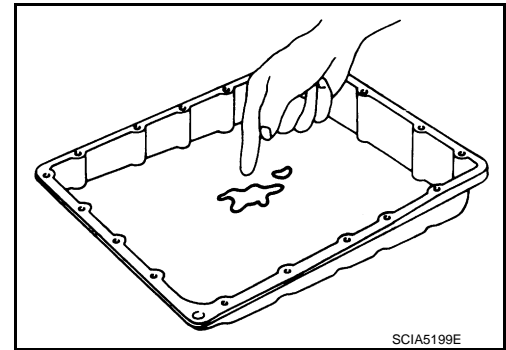

- Check torque converter one-way clutch using a check tool as shown at figure.
1. Insert a check tool into the groove of bearing support built into one-way clutch outer race.
 2. When fixing bearing support with a check tool, rotate one-way clutch spline using a screwdriver.
 3. Make sure that inner race rotates clockwise only. If not, replace torque converter assembly.

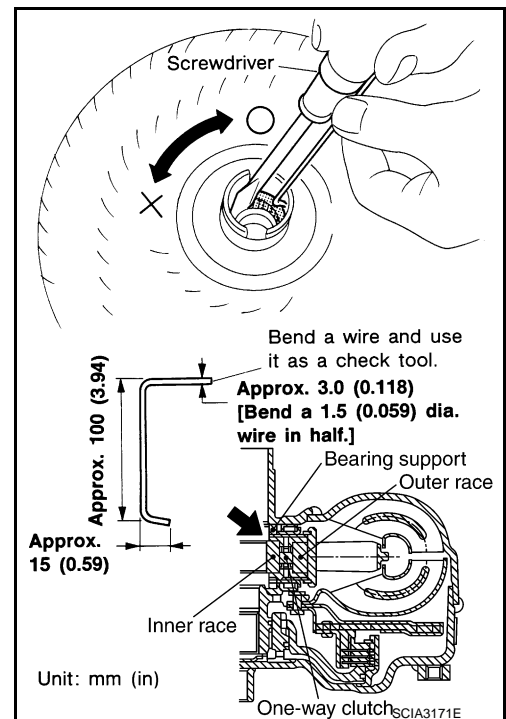

OIL PUMP

< UNIT DISASSEMBLY AND ASSEMBLY >

[5AT: RE5R05A]

OIL PUMP

Exploded View

INFOID:000000004343056

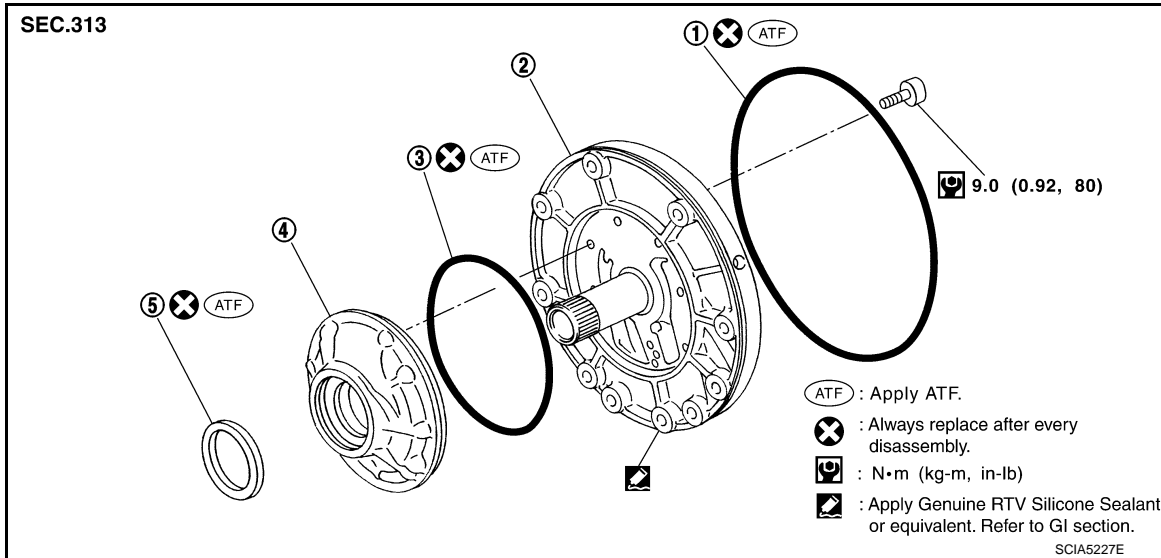

1. O-ring
2. Oil pump cover
3. O-ring
4. Oil pump housing
5. Oil pump housing oil seal

Disassembly

INFOID:000000004343057

1. Remove oil pump housing from oil pump cover.

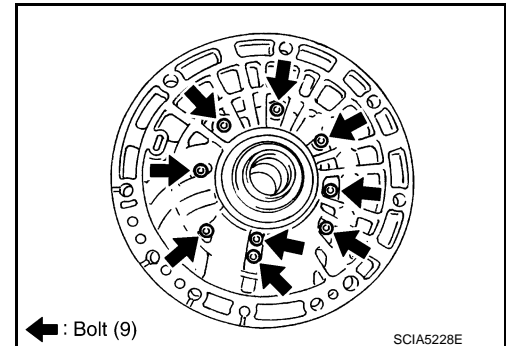

2. Remove oil pump housing oil seal with a flat-bladed screwdriver.
CAUTION:
Be careful not to scratch oil pump housing.

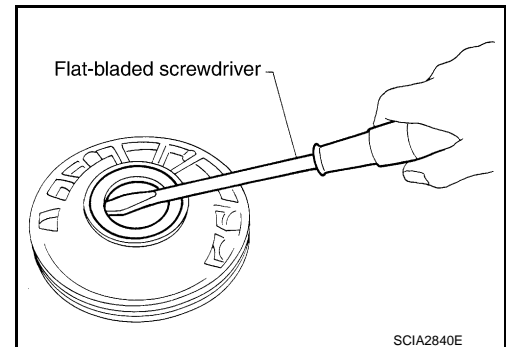

OIL PUMP

< UNIT DISASSEMBLY AND ASSEMBLY >

[5AT: RE5R05A]

3. Remove O-ring from oil pump housing.

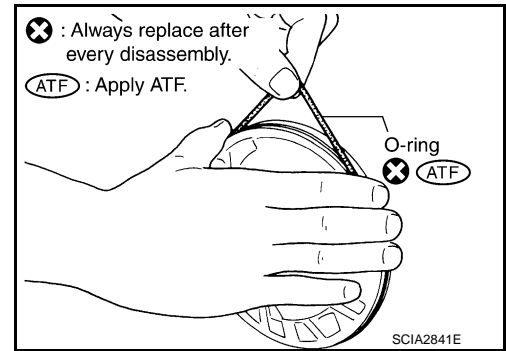

4. Remove O-ring from oil pump cover.

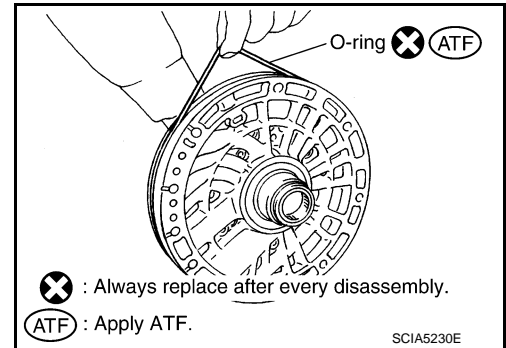

Assembly

INFOID:000000004343058

1. Install O-ring to oil pump cover.

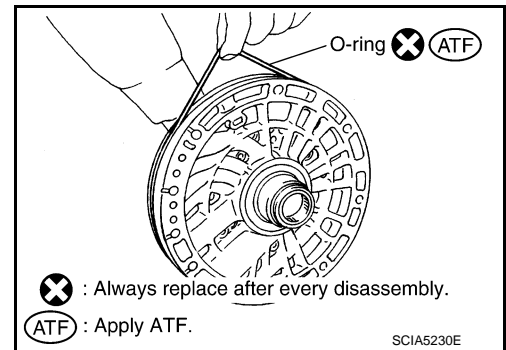

2. Install O-ring to oil pump housing.

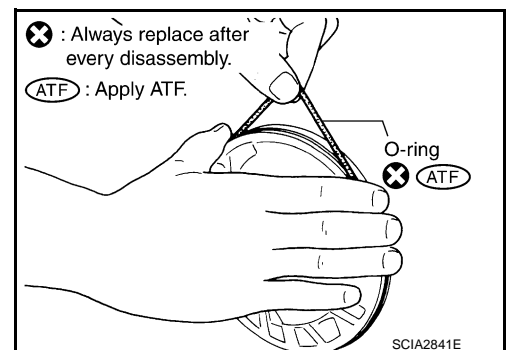

OIL PUMP

< UNIT DISASSEMBLY AND ASSEMBLY >

[5AT: RE5R05A]

- Using the drift, install oil pump housing oil seal to the oil pump housing until it is flush.

CAUTION:

- Never reuse oil seal.
- Apply ATF to oil seal.

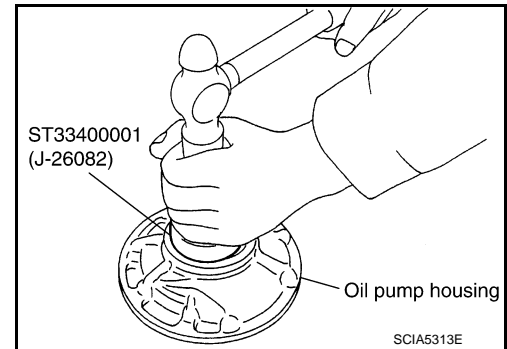

- Install oil pump housing to oil pump cover.
- Tighten bolts (←) to the specified torque in numerical order shown in the figure after temporarily tightening them.

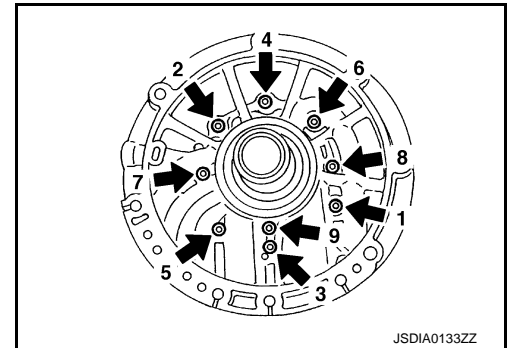

A
B
C
TM
E
F
G
H
I
J
K
L
M
N
O
P

FRONT SUN GEAR, 3RD ONE-WAY CLUTCH

< UNIT DISASSEMBLY AND ASSEMBLY >

[5AT: RE5R05A]

FRONT SUN GEAR, 3RD ONE-WAY CLUTCH

Exploded View

INFOID:000000004343059

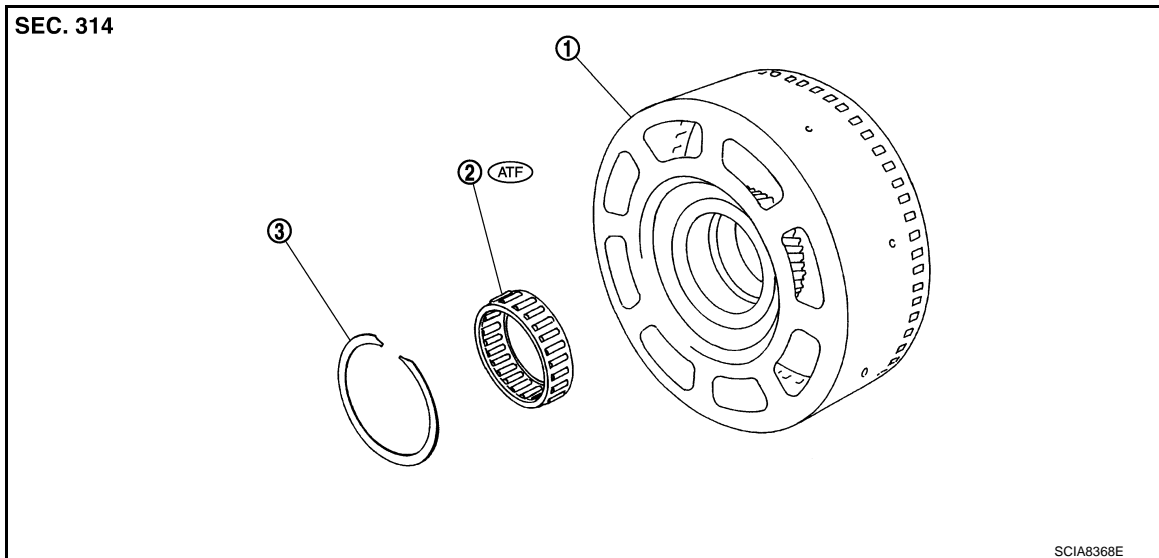

1. Front sun gear

2. 3rd one-way clutch

3. Snap ring

Refer to [GI-4, "Components"](#) for symbols in the figure.

Disassembly

INFOID:000000004343060

1. Remove snap ring from front sun gear with a flat-bladed screwdriver.

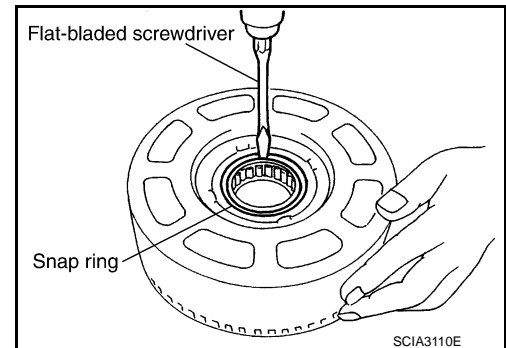

2. Remove 3rd one-way clutch from front sun gear.

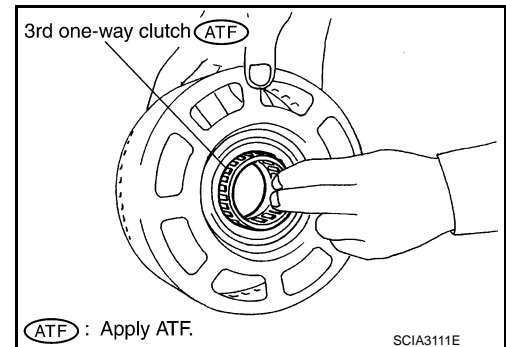

FRONT SUN GEAR, 3RD ONE-WAY CLUTCH

< UNIT DISASSEMBLY AND ASSEMBLY >

[5AT: RE5R05A]

Assembly

INFOID:000000004343061

1. Install 3rd one-way clutch to front sun gear.

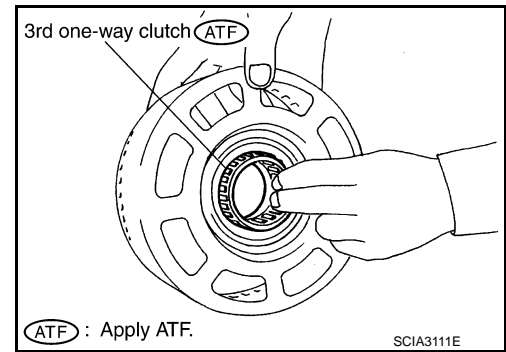

2. Install snap ring to front sun gear with a flat-bladed screwdriver.

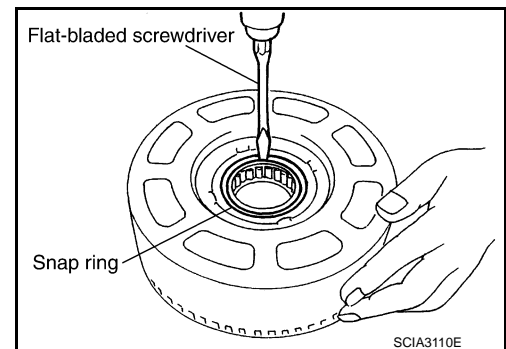

3. Check operation of 3rd one-way clutch.
 - a. Hold oil pump assembly and turn front sun gear.
 - b. Check 3rd one-way clutch for correct locking and unlocking directions.

CAUTION:

If not as shown in figure, check installation direction of 3rd one-way clutch.

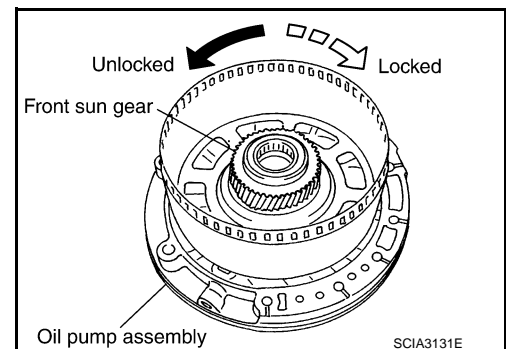

Inspection

INFOID:000000004343062

- 3rd One-way Clutch
Check frictional surface for wear or damage.
CAUTION:
If necessary, replace the 3rd one-way clutch.
- Front Sun Gear Snap Ring
Check for deformation, fatigue or damage.
CAUTION:
If necessary, replace the snap ring.
- Front Sun Gear
Check for deformation, fatigue or damage.
CAUTION:
If necessary, replace the front sun gear.

A
B
C
TM
E
F
G
H
I
J
K
L
M
N
O
P

FRONT CARRIER, INPUT CLUTCH, REAR INTERNAL GEAR

< UNIT DISASSEMBLY AND ASSEMBLY >

[5AT: RE5R05A]

FRONT CARRIER, INPUT CLUTCH, REAR INTERNAL GEAR

Exploded View

INFOID:000000004343063

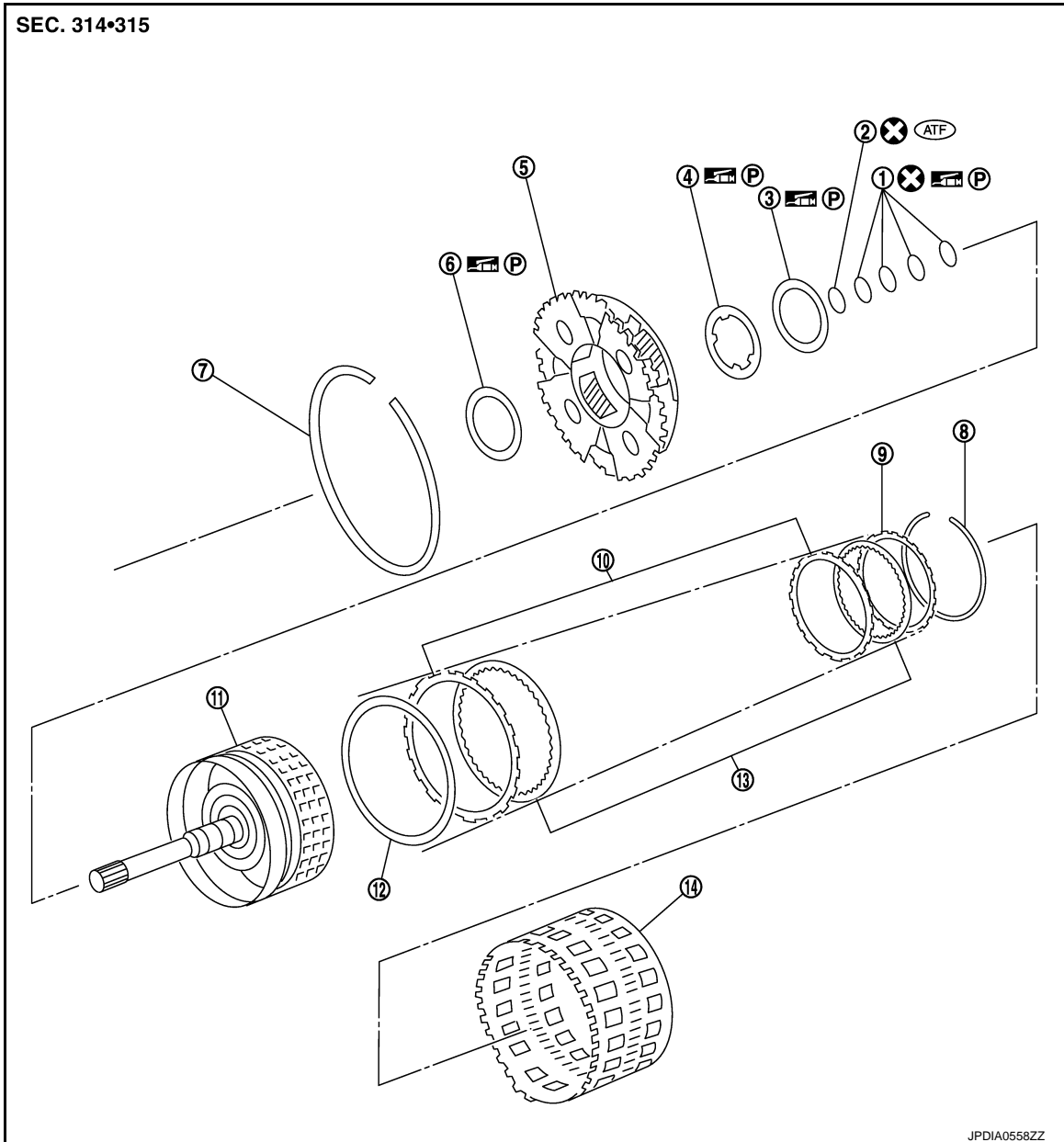

- | | | |
|------------------|---------------------------|--------------------|
| 1. Seal ring | 2. O-ring | 3. Needle bearing |
| 4. Bearing race | 5. Front carrier assembly | 6. Needle bearing |
| 7. Snap ring | 8. Snap ring | 9. Retaining plate |
| 10. Driven plate | 11. Input clutch drum | 12. Dish plate |
| 13. Drive plate | 14. Rear internal gear | |

Refer to [GI-4. "Components"](#) for symbols in the figure.

FRONT CARRIER, INPUT CLUTCH, REAR INTERNAL GEAR

< UNIT DISASSEMBLY AND ASSEMBLY >

[5AT: RE5R05A]

Disassembly

INFOID:000000004343064

1. Compress snap ring with two flat-bladed screwdrivers.
2. Remove front carrier assembly and input clutch assembly from rear internal gear.
3. Remove front carrier assembly from input clutch assembly.

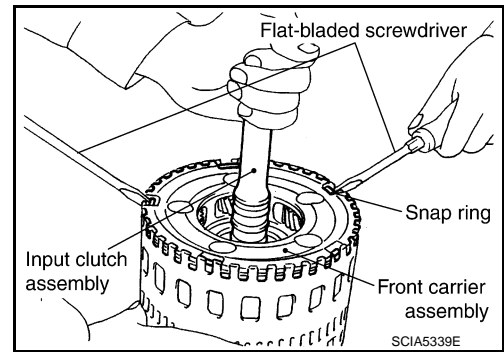

4. Remove bearing race from front carrier assembly.

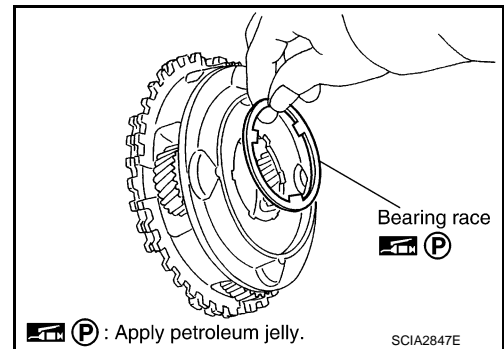

5. Remove needle bearing from front carrier assembly.

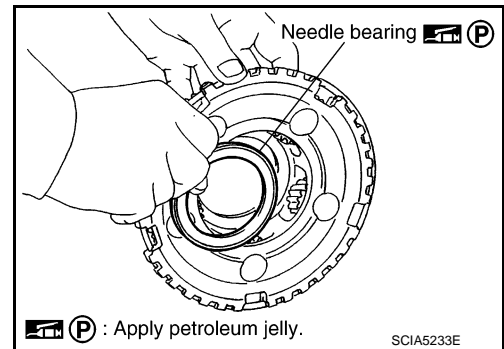

6. Remove snap ring from front carrier assembly.
CAUTION:
Never expand snap ring excessively.

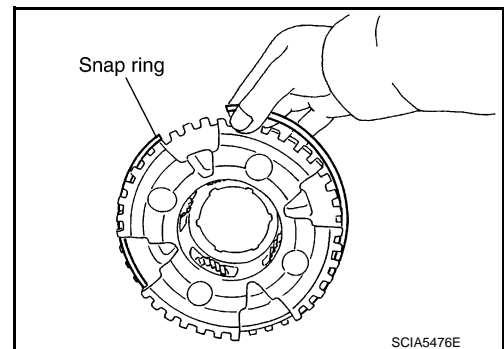

A
B
C
TM
E
F
G
H
I
J
K
L
M
N
O
P

FRONT CARRIER, INPUT CLUTCH, REAR INTERNAL GEAR

< UNIT DISASSEMBLY AND ASSEMBLY >

[5AT: RE5R05A]

7. Remove O-ring and seal rings from input clutch assembly.

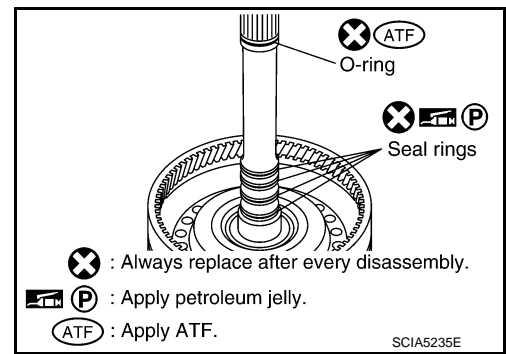

8. Remove needle bearing from input clutch assembly.

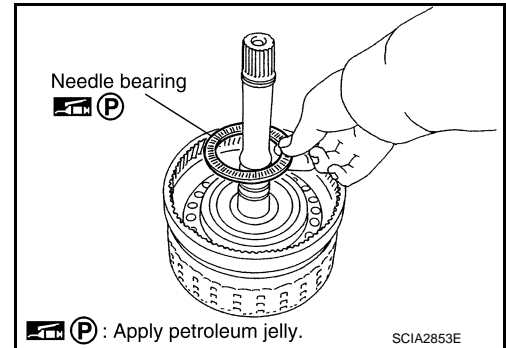

9. Remove snap ring from input clutch drum with a flat-bladed screwdriver.

10. Remove drive plates, driven plates, dish plate and retaining plate from input clutch drum.

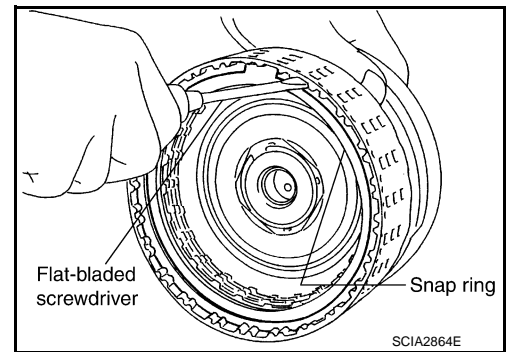

Assembly

INFOID:000000004343065

1. Install drive plates, driven plates, dish plate, retaining plate and snap ring to input clutch drum.

- 1 : Snap ring
- 2 : Retaining plate
- 3 : Drive plate
- 4 : Driven plate
- 5 : Dish plate
- 7 / 7 : Drive plate / Driven plate

CAUTION:
Check order of plates.

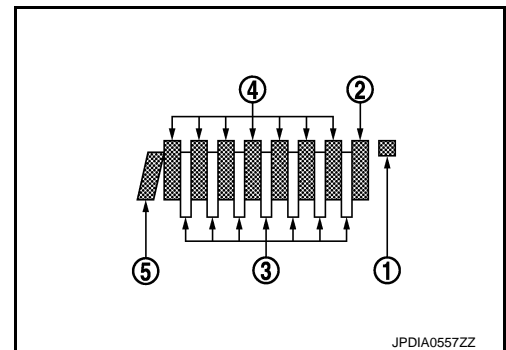

FRONT CARRIER, INPUT CLUTCH, REAR INTERNAL GEAR

< UNIT DISASSEMBLY AND ASSEMBLY >

[5AT: RE5R05A]

- Install snap ring to input clutch drum with a flat-bladed screwdriver.

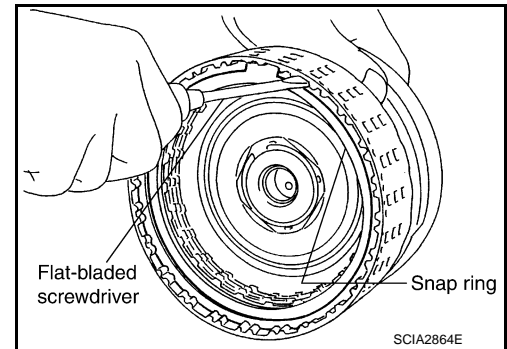

- Install needle bearing to input clutch assembly.

CAUTION:
Check the direction of needle bearing. Refer to [TM-210, "Location of Adjusting Shims, Needle Bearings, Thrust Washers and Snap Rings"](#).

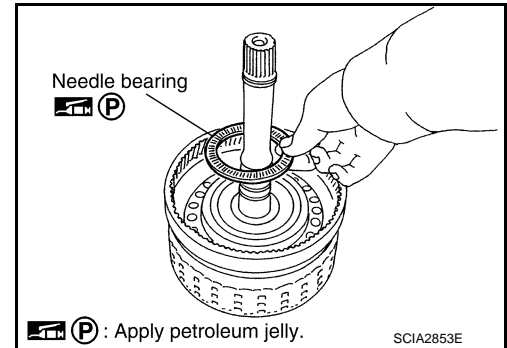

- Install O-ring and seal rings to input clutch assembly.

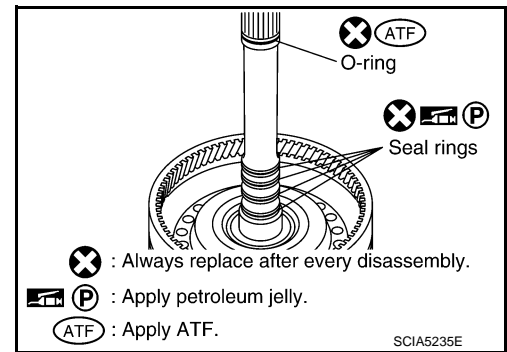

- Install snap ring to front carrier assembly.

CAUTION:
Never expand snap ring excessively.

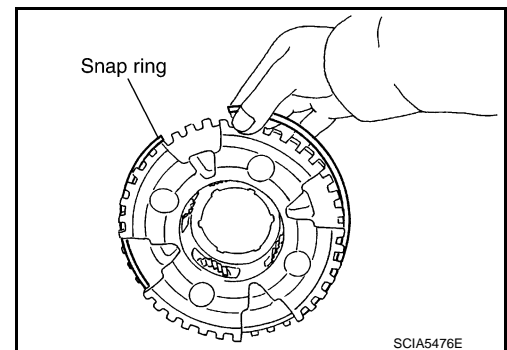

- Install needle bearing to front carrier assembly.

CAUTION:
Check the direction of needle bearing. Refer to [TM-210, "Location of Adjusting Shims, Needle Bearings, Thrust Washers and Snap Rings"](#).

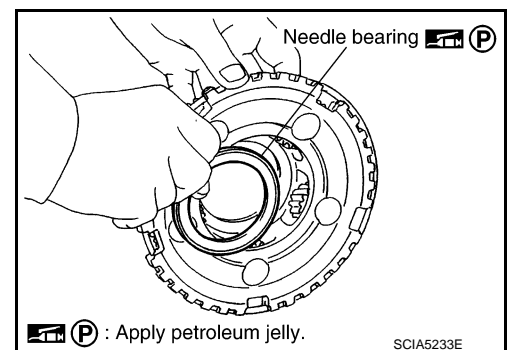

A
B
C
TM
E
F
G
H
I
J
K
L
M
N
O
P

FRONT CARRIER, INPUT CLUTCH, REAR INTERNAL GEAR

< UNIT DISASSEMBLY AND ASSEMBLY >

[5AT: RE5R05A]

7. Install bearing race to front carrier assembly.
8. Install front carrier assembly to input clutch assembly.

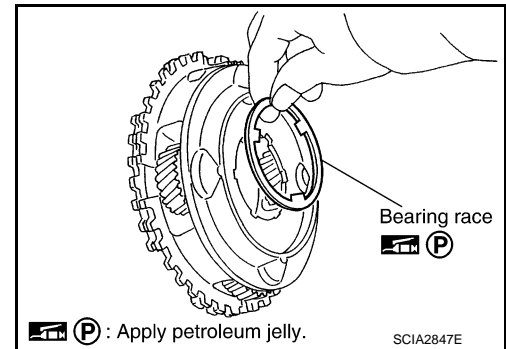

9. Compress snap ring with two flat-bladed screwdrivers.
10. Install front carrier assembly and input clutch assembly to rear internal gear.

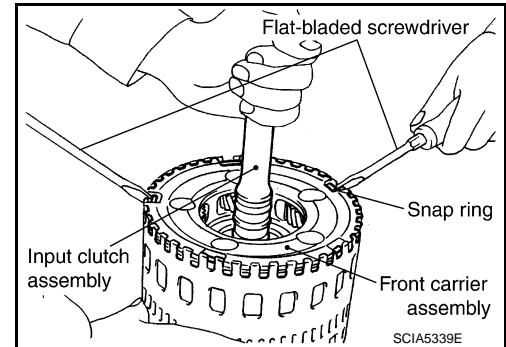

Inspection

- Front Carrier Snap Ring
Check for deformation, fatigue or damage.
CAUTION:
If necessary, replace the snap ring.
- Input Clutch Snap Ring
Check for deformation, fatigue or damage.
CAUTION:
If necessary, replace the input clutch assembly.
- Input Clutch Drum
Check for deformation, fatigue or damage or burns.
CAUTION:
If necessary, replace the input clutch assembly.
- Input Clutch Drive Plates and Driven Plates
Check facing for burns, cracks or damage.
CAUTION:
If necessary, replace the input clutch assembly.
- Input Clutch Retaining Plate and Dish Plate
Check facing for burns, cracks or damage.
CAUTION:
If necessary, replace the input clutch assembly.
- Front Carrier
Check for deformation, fatigue or damage.
CAUTION:
If necessary, replace the front carrier assembly.
- Rear Internal Gear
Check for deformation, fatigue or damage.
CAUTION:
If necessary, replace the rear internal gear.

INFOID:000000004343066

MID SUN GEAR, REAR SUN GEAR, HIGH AND LOW REVERSE CLUTCH HUB

< UNIT DISASSEMBLY AND ASSEMBLY > [5AT: RE5R05A]

MID SUN GEAR, REAR SUN GEAR, HIGH AND LOW REVERSE CLUTCH HUB

Exploded View

INFOID:000000004343067

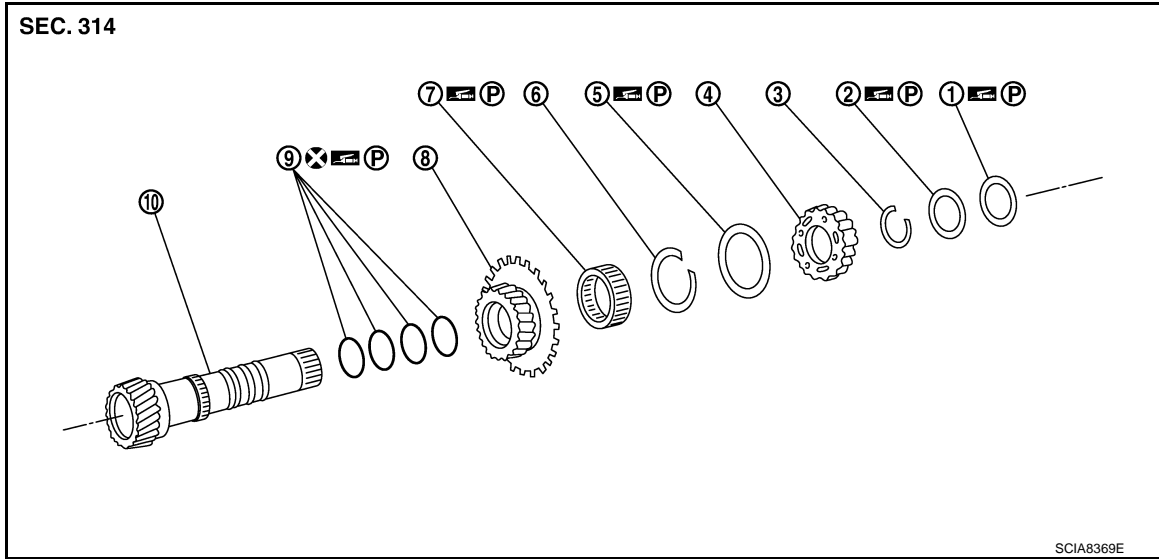

- | | | |
|------------------------------------|-------------------|--------------|
| 1. Needle bearing | 2. Bearing race | 3. Snap ring |
| 4. High and low reverse clutch hub | 5. Needle bearing | 6. Snap ring |
| 7. 1st one-way clutch | 8. Rear sun gear | 9. Seal ring |
| 10. Mid sun gear | | |

Refer to [GI-4, "Components"](#) for symbols in the figure.

Disassembly

INFOID:000000004343068

1. Remove needle bearing and bearing race from high and low reverse clutch hub.

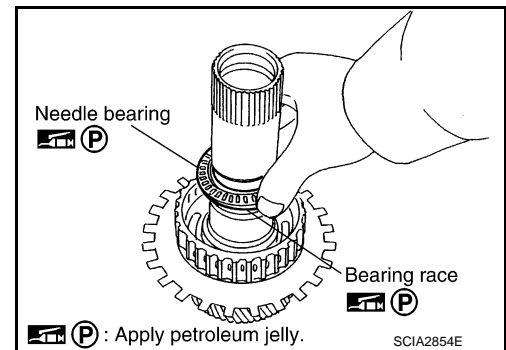

2. Remove snap ring from mid sun gear assembly with pair of snap ring pliers.

CAUTION:
Never expand snap ring excessively.

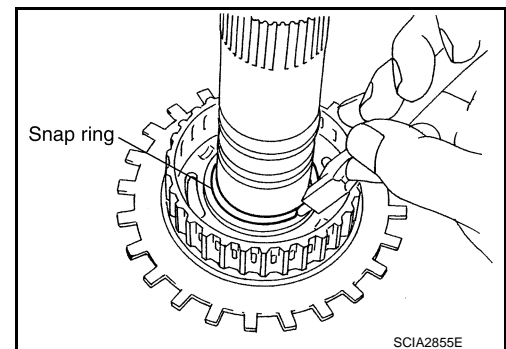

MID SUN GEAR, REAR SUN GEAR, HIGH AND LOW REVERSE CLUTCH HUB

< UNIT DISASSEMBLY AND ASSEMBLY >

[5AT: RE5R05A]

3. Remove high and low reverse clutch hub from mid sun gear assembly.

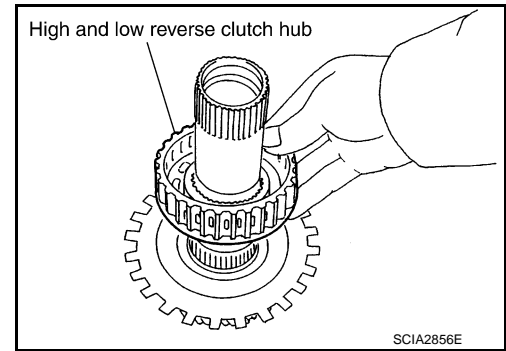

4. Remove needle bearing from high and low reverse clutch hub.

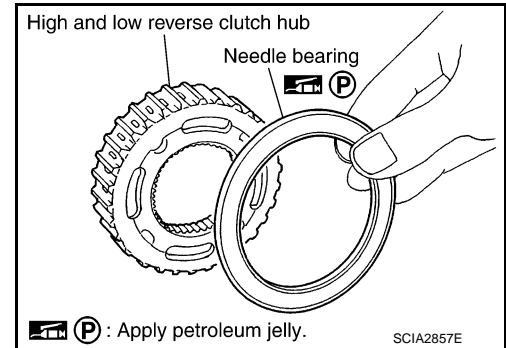

5. Remove rear sun gear assembly from mid sun gear assembly.

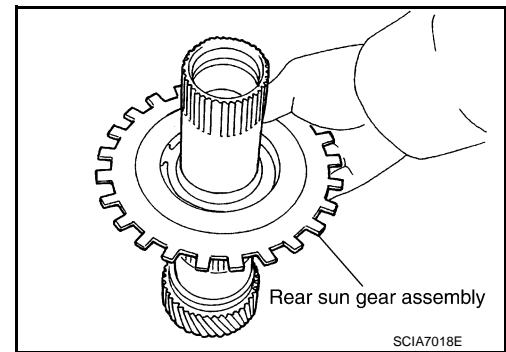

6. Remove snap ring from rear sun gear with a flat-bladed screwdriver.

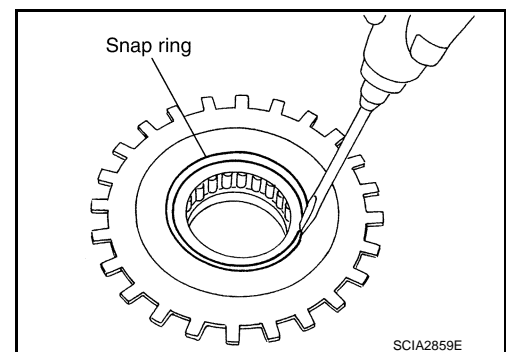

7. Remove 1st one-way clutch from rear sun gear.

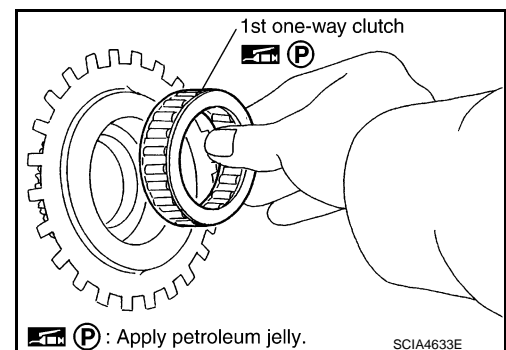

MID SUN GEAR, REAR SUN GEAR, HIGH AND LOW REVERSE CLUTCH HUB

< UNIT DISASSEMBLY AND ASSEMBLY >

[5AT: RE5R05A]

8. Remove seal rings from mid sun gear.

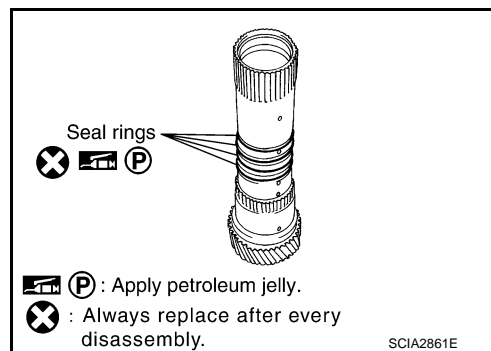

Assembly

INFOID:000000004343069

1. Install seal rings to mid sun gear.

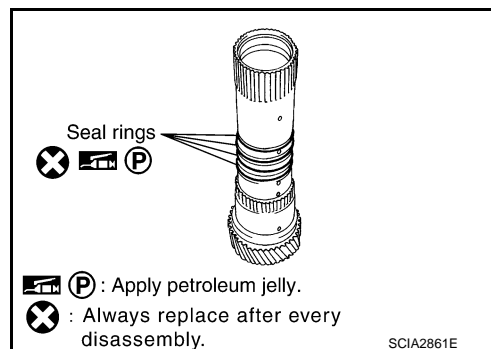

2. Install 1st one-way clutch to rear sun gear.

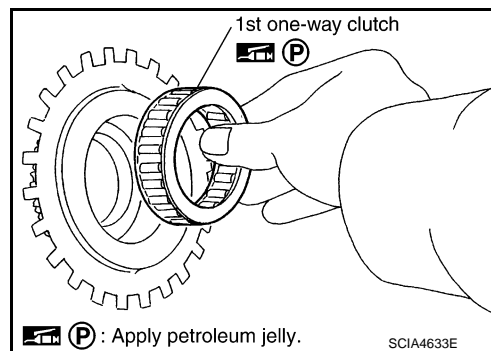

3. Install snap ring to rear sun gear with a flat-bladed screwdriver.

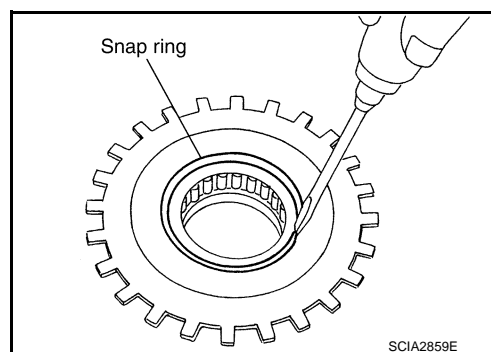

A
B
C
TM
E
F
G
H
I
J
K
L
M
N
O
P

MID SUN GEAR, REAR SUN GEAR, HIGH AND LOW REVERSE CLUTCH HUB

< UNIT DISASSEMBLY AND ASSEMBLY >

[5AT: RE5R05A]

4. Install rear sun gear assembly to mid sun gear assembly.

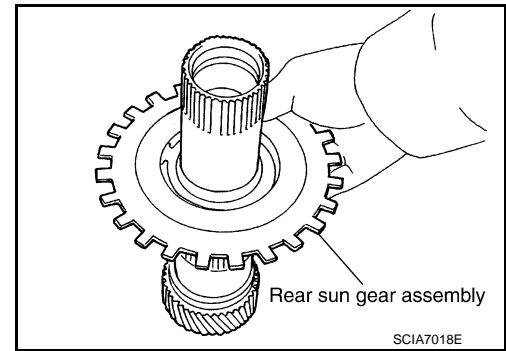

5. Install needle bearing to high and low reverse clutch hub.

CAUTION:

Check the direction of needle bearing. Refer to [TM-210, "Location of Adjusting Shims, Needle Bearings, Thrust Washers and Snap Rings"](#).

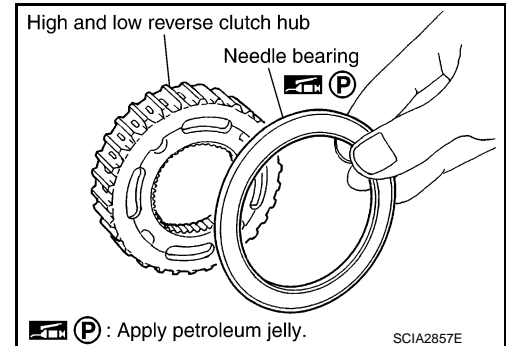

6. Install high and low reverse clutch hub to mid sun gear assembly.

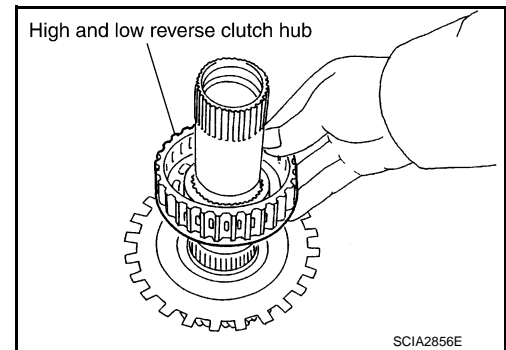

7. Install snap ring to mid sun gear assembly with pair of snap ring pliers.

CAUTION:

Never expand snap ring excessively.

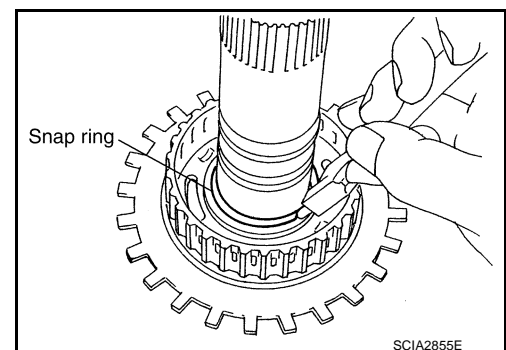

8. Check operation of 1st one-way clutch.

- a. Hold mid sun gear and turn rear sun gear.

- b. Check 1st one-way clutch for correct locking and unlocking directions.

CAUTION:

If not as shown in the figure, check installation direction of 1st one-way clutch.

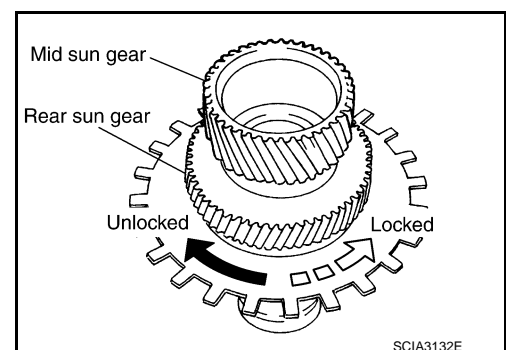

MID SUN GEAR, REAR SUN GEAR, HIGH AND LOW REVERSE CLUTCH HUB

< UNIT DISASSEMBLY AND ASSEMBLY >

[5AT: RE5R05A]

9. Install needle bearing and bearing race to high and low reverse clutch hub.

CAUTION:

Check the direction of needle bearing. Refer to [TM-210](#), "[Location of Adjusting Shims, Needle Bearings, Thrust Washers and Snap Rings](#)".

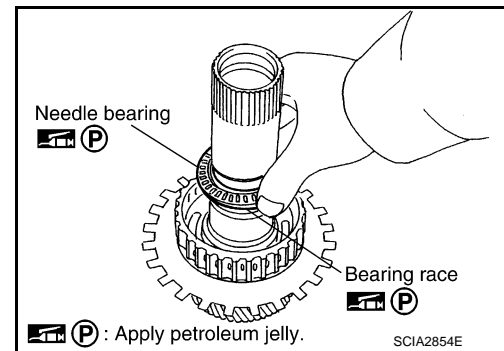

Inspection

INFOID:000000004343070

- High and Low Reverse Clutch Hub Snap Ring, Rear Sun Gear Snap Ring
Check for deformation, fatigue or damage.

CAUTION:

If necessary, replace the snap ring.

- 1st One-way Clutch
Check frictional surface for wear or damage.

CAUTION:

If necessary, replace the 1st one-way clutch.

- Mid Sun Gear
Check for deformation, fatigue or damage.

CAUTION:

If necessary, replace the mid sun gear.

- Rear Sun Gear
Check for deformation, fatigue or damage.

CAUTION:

If necessary, replace the rear sun gear.

- High and Low Reverse Clutch Hub
Check for deformation, fatigue or damage.

CAUTION:

If necessary, replace the high and low reverse clutch hub.

HIGH AND LOW REVERSE CLUTCH

< UNIT DISASSEMBLY AND ASSEMBLY >

[5AT: RE5R05A]

HIGH AND LOW REVERSE CLUTCH

Exploded View

INFOID:000000004343071

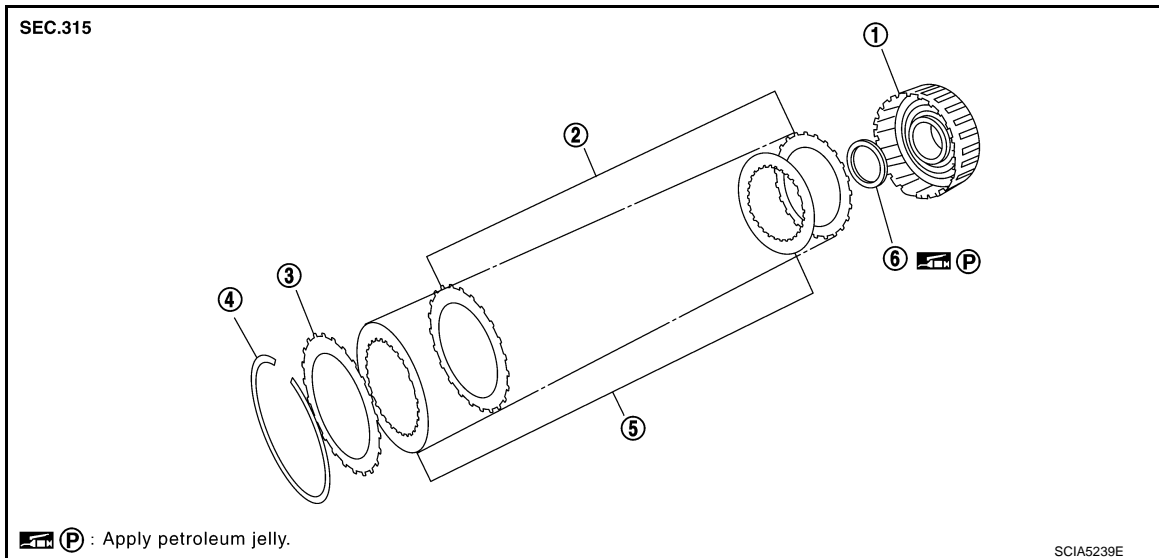

- | | | |
|-------------------------------------|-----------------|--------------------|
| 1. High and low reverse clutch drum | 2. Driven plate | 3. Retaining plate |
| 4. Snap ring | 5. Drive plate | 6. Bearing race |

Disassembly

INFOID:000000004343072

1. Remove bearing race from high and low reverse clutch drum.

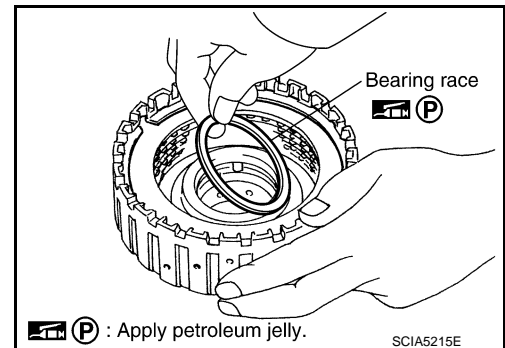

2. Remove snap ring from high and low reverse clutch drum with a flat-bladed screwdriver.
3. Remove drive plates, driven plates and retaining plate from high and low reverse clutch drum.

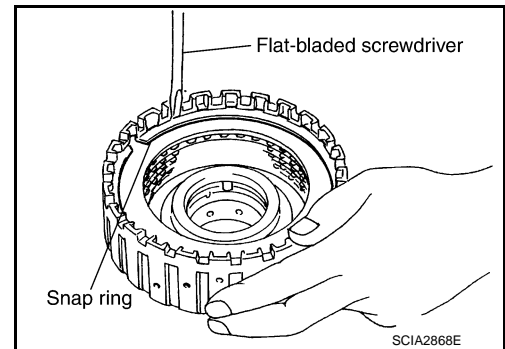

Assembly

INFOID:000000004343073

1. Install drive plates, driven plates, retaining plate and snap ring to high and low reverse clutch drum.

CAUTION:

HIGH AND LOW REVERSE CLUTCH

< UNIT DISASSEMBLY AND ASSEMBLY >

[5AT: RE5R05A]

Check the order of plates.

- 1 : Snap ring
- 2 : Retaining plate
- 3 : Drive plate
- 4 : Driven plate
- 4/4 : Drive plate / Driven plate

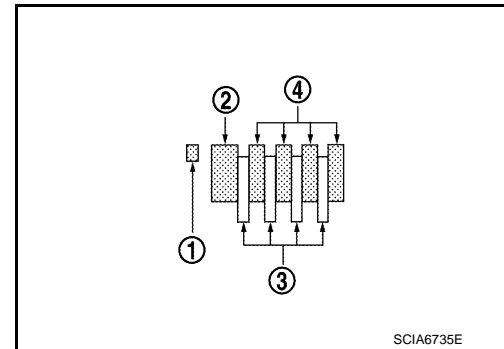

2. Install snap ring to high and low reverse clutch drum with a flat-bladed screwdriver.

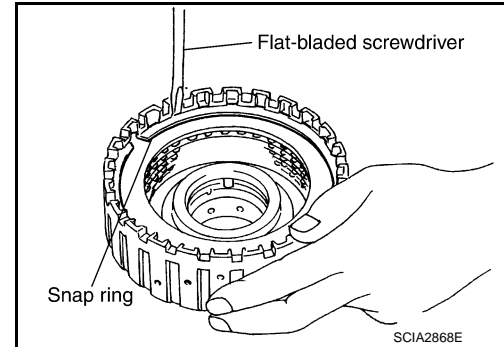

3. Install bearing race to high and low reverse clutch drum.

CAUTION:

Check the direction of needle bearing. Refer to [TM-210, "Location of Adjusting Shims, Needle Bearings, Thrust Washers and Snap Rings"](#).

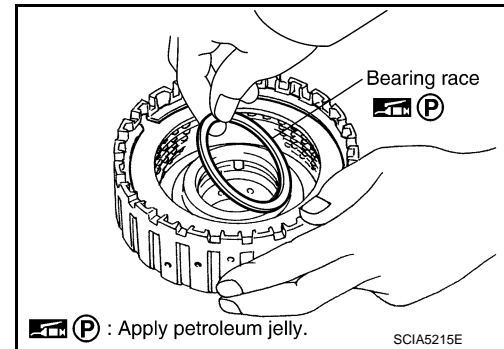

Inspection

INFOID:000000004343074

Check the following, and replace transmission assembly if necessary.

- High and Low Reverse Clutch Snap Ring
Check for deformation, fatigue or damage.
- High and Low Reverse Clutch Drive Plates
Check facing for burns, cracks or damage.
- High and Low Reverse Clutch Retaining Plate and Driven Plates
Check facing for burns, cracks or damage.

DIRECT CLUTCH

< UNIT DISASSEMBLY AND ASSEMBLY >

[5AT: RE5R05A]

DIRECT CLUTCH

Exploded View

INFOID:000000004343075

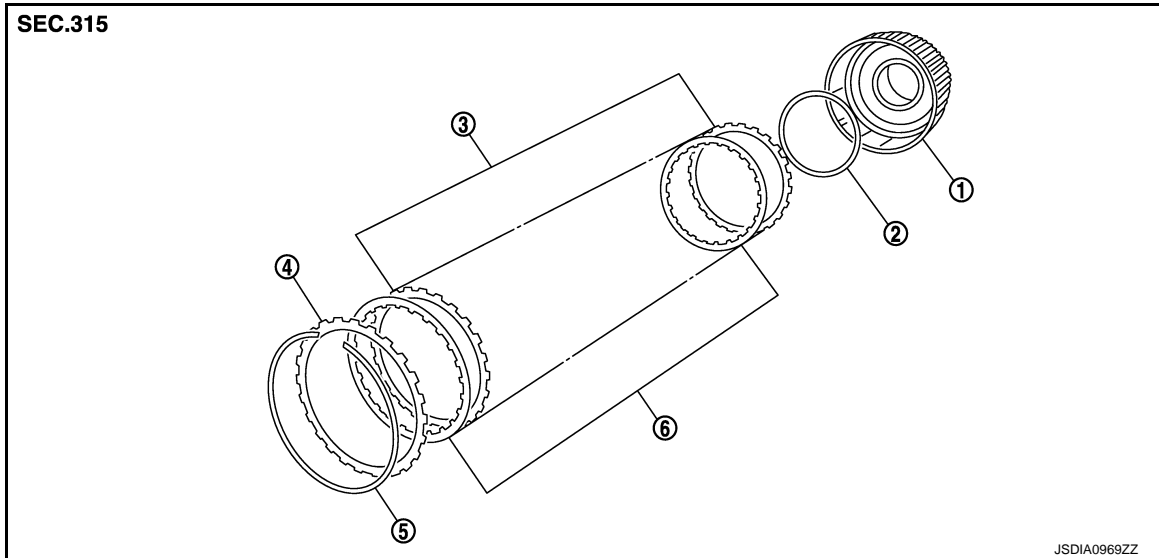

- | | | |
|-----------------------|---------------|-----------------|
| 1. Direct clutch drum | 2. Dish plate | 3. Driven plate |
| 4. Retaining plate | 5. Snap ring | 6. Drive plate |

Disassembly

INFOID:000000004343076

1. Remove snap ring from direct clutch drum with a flat-bladed screwdriver.
2. Remove drive plates, driven plates, dish plate and retaining plates from direct clutch drum.

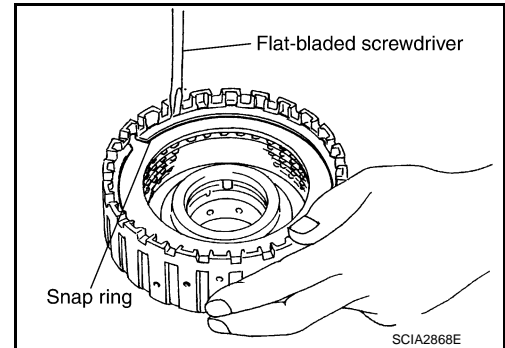

Assembly

INFOID:000000004343077

1. Install drive plates, driven plates, dish plate, retaining plates and snap ring to direct clutch drum.

CAUTION:
Check the order of plates.

- | | |
|-------|------------------------------|
| 1 | : Snap ring |
| 2 | : Retaining plate |
| 3 | : Drive plate |
| 4 | : Driven plate |
| 5 | : Dish plate |
| 5 / 5 | : Drive plate / Driven plate |

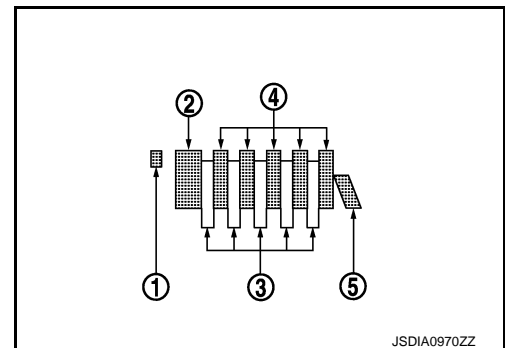

DIRECT CLUTCH

< UNIT DISASSEMBLY AND ASSEMBLY >

[5AT: RE5R05A]

2. Install snap ring to direct clutch drum with a flat-bladed screwdriver.

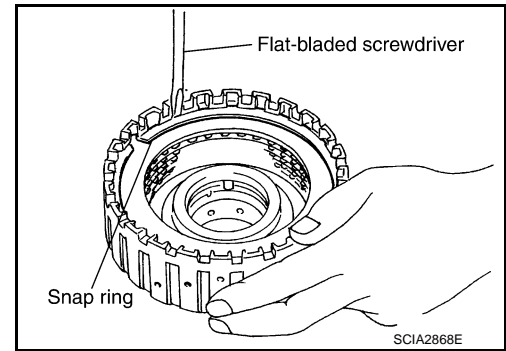

Inspection

INFOID:000000004343078

Check the following, and replace direct clutch assembly if necessary.

- Direct Clutch Snap Ring
Check for deformation, fatigue or damage.
- Direct Clutch Drive Plates and Driven Plates
Check facing for burns, cracks or damage.
- Direct Clutch Dish Plate and Retaining Plates
Check facing for burns, cracks or damage.

A
B
C
TM
E
F
G
H
I
J
K
L
M
N
O
P

SERVICE DATA AND SPECIFICATIONS (SDS)

< SERVICE DATA AND SPECIFICATIONS (SDS)

[5AT: RE5R05A]

SERVICE DATA AND SPECIFICATIONS (SDS)

SERVICE DATA AND SPECIFICATIONS (SDS)

General Specification

INFOID:000000004343079

Applied model	VQ35HR engine	
	2WD	AWD
Automatic transmission model	RE5R05A	
Transmission model code number	3EX4C	3EX4D
Stall torque ratio	1.74 : 1	
Transmission gear ratio	1st	3.842
	2nd	2.353
	3rd	1.529
	4th	1.000
	5th	0.839
	Reverse	2.765
Recommended fluid	Genuine NISSAN Matic S ATF*1	
Fluid capacity	10.3 liter (10-7/8 US qt, 9-1/8 Imp qt)*2	

CAUTION:

- If Genuine NISSAN Matic S ATF is not available, Genuine NISSAN Matic J ATF may also be used.
- Using ATF other than Genuine NISSAN Matic S ATF or Matic J ATF will cause deterioration in driveability and A/T durability, and may damage the A/T, which is not covered by the INFINITI new vehicle limited warranty.

*1: Refer to [MA-10, "Fluids and Lubricants"](#).

*2: The fluid capacity is the reference value. Check the fluid level with A/T fluid level gauge.

Vehicle Speed at Which Gear Shifting Occurs

INFOID:000000004343080

Throttle position	Vehicle speed km/h (MPH)							
	D1→D2	D2→D3	D3→D4	D4→D5	D5→D4	D4→D3	D3→D2	D2→D1
Full throttle	70 – 74 (44 – 45)	114 – 122 (71 – 75)	172 – 182 (107 – 113)	246 – 256 (153 – 159)	242 – 252 (151 – 156)	157 – 167 (98 – 103)	98 – 106 (61 – 65)	43 – 47 (27 – 29)
Half throttle	47 – 51 (30 – 31)	77 – 83 (48 – 51)	100 – 108 (63 – 67)	167 – 175 (104 – 108)	137 – 145 (86 – 90)	63 – 71 (40 – 44)	32 – 38 (20 – 23)	7 – 11 (5 – 6)

- At half throttle, the accelerator opening is 4/8 of the full opening.

Vehicle Speed at Which Lock-up Occurs/Releases

INFOID:000000004343081

Throttle position	Vehicle speed km/h (MPH)	
	Lock-up ON	Lock-up OFF
Closed throttle	57 – 65 (36 – 40)	54 – 62 (34 – 38)
Half throttle	167 – 175 (104 – 108)	137 – 145 (86 – 90)

- At closed throttle, the accelerator opening is less than 1/8 condition. (Closed throttle position signal OFF)
- At half throttle, the accelerator opening is 4/8 of the full opening.

Stall Speed

INFOID:000000004343082

Stall speed	2,700 – 3,000 rpm
-------------	-------------------

SERVICE DATA AND SPECIFICATIONS (SDS)

< SERVICE DATA AND SPECIFICATIONS (SDS)

[5AT: RE5R05A]

Line Pressure

INFOID:000000004343083

Engine speed	Line pressure kPa (kg/cm ² , psi)	
	"R" position	"D" and "M" positions
At idle speed	425 – 465 (4.4 – 4.7, 62 – 67)	379 – 428 (3.9 – 4.3, 55 – 62)
At stall speed	1,605 – 1,950 (16.4 – 19.8, 233 – 282)	1,310 – 1,500 (13.4 – 15.3, 190 – 217)

Input Speed Sensor

INFOID:000000004343084

Name	Condition	Data (Approx.)
Input speed sensor 1	When running at 50 km/h (31 MPH) in 4th speed with the closed throttle position signal OFF.	1.3 kHz
Input speed sensor 2	When running at 20 km/h (12 MPH) in 1st speed with the closed throttle position signal OFF.	

Output Speed Sensor

INFOID:000000004343085

Name	Condition	Data (Approx.)
Output speed sensor	When running at 20 km/h (12 MPH).	185 Hz

Reverse Brake

INFOID:000000004343086

Number of drive plates	6	
Number of driven plates	6	
Clearance mm (in)	Standard	0.7 – 1.1 (0.028 – 0.043)
Thickness of retaining plates mm (in)	4.2 (0.165)	
	4.4 (0.173)	
	4.6 (0.181)	
	4.8 (0.189)	
	5.0 (0.197)	
	5.2 (0.205)	
		5.4 (0.213)

Total End Play

INFOID:000000004343087

Total end play mm (in)	0.25 – 0.55 (0.0098 – 0.0217)
------------------------	-------------------------------

BEARING RACE FOR ADJUSTING TOTAL END PLAY

Thickness mm (in)	0.8 (0.031)
	1.0 (0.039)
	1.2 (0.047)
	1.4 (0.055)
	1.6 (0.063)
	1.8 (0.071)

Torque Converter

INFOID:000000004343088

Distance between end of converter housing and torque converter mm (in)	25.0 (0.98)
--	-------------