

SECTION **BRM**
BODY REPAIR

A
B
C
D
E
F
G
H
I
J
L
M
N
O
P

CONTENTS

VEHICLE INFORMATION	2	Radiator Core Support	26
BODY EXTERIOR PAINT COLOR	2	Hoodledge	26
Body Exterior Paint Color	2	Front Side Member (2WD)	28
PRECAUTION	4	Front Side Member (AWD)	31
REPAIRING HIGH STRENGTH STEEL	4	Front Side Member (Partial Replacement)	34
High Strength Steel (HSS)	4	Front Pillar	35
PREPARATION	7	Front Pillar (Partial Replacement)	38
REPAIRING MATERIAL	7	Center Pillar	41
Foam Repair	7	Outer Sill	43
BODY COMPONENT PARTS	9	Rear Fender	47
Underbody Component Parts	9	Rear Panel	49
Body Component Parts	11	Rear End Crossmember	49
REMOVAL AND INSTALLATION	13	Rear Floor Rear	50
CORROSION PROTECTION	13	Rear Side Member Extension	51
Description	13	SERVICE DATA AND SPECIFICATIONS	
Anti-corrosive Wax	13	(SDS)	53
Undercoating	14	BODY ALIGNMENT	53
Body Sealing	15	Body Center Marks	53
BODY CONSTRUCTION	22	Description	54
Body Construction	22	Engine Compartment	54
REPLACEMENT OPERATIONS	24	Underbody (2WD)	56
Description	24	Underbody (AWD)	59
		Passenger Compartment	62
		Rear Body	64
		LOCATION OF PLASTIC PARTS	66
		Precautions for Plastics	66
		Location of Plastic Parts	67

BRM

BODY EXTERIOR PAINT COLOR

< VEHICLE INFORMATION >

VEHICLE INFORMATION

BODY EXTERIOR PAINT COLOR

Body Exterior Paint Color

INFOID:000000005172871

FOR USA AND CANADA

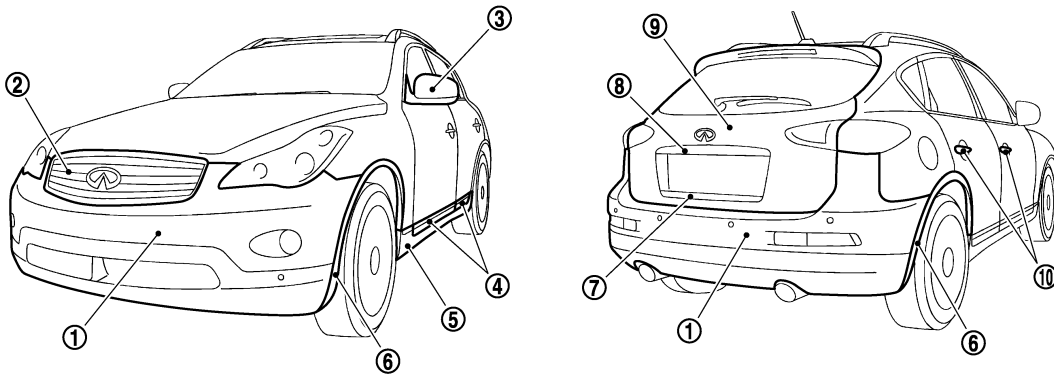

JSKIA0579ZZ

Component		Color code	BFAA	BKAG	BKH3	BK23	BK51	BK52	BL50	BQAA	
		Description	Grayish Green	Reddish Silver	Black	Silver	Gray	Dark Gray	Brownish Purple	White	
		Paint type ^{note}	TPM	M	2S	M	M	PM	P	3P	
		Hard clear coat	×	-	×	-	-	×	×	-	
1	Bumper fascia	Body color	BFAA	BKAG	BKH3	BK23	BK51	BK52	BL50	BQAA	
		Material color	-	-	-	-	-	-	-	-	
2	Front grille	Chromium-plate	Cr	Cr	Cr	Cr	Cr	Cr	Cr	Cr	
3	Door outside mirror	Cover	Body color	BFAA	BKAG	BKH3	BK23	BK51	BK52	BL50	BQAA
			Material color	-	-	-	-	-	-	-	-
4	Side guard molding	Chromium-plate	Cr	Cr	Cr	Cr	Cr	Cr	Cr	Cr	
		Material color	-	-	-	-	-	-	-	-	
5	Center mud-guard	Chromium-plate	Cr	Cr	Cr	Cr	Cr	Cr	Cr	Cr	
		Material color	-	-	-	-	-	-	-	-	
6	Fillet molding	Material color	-	-	-	-	-	-	-	-	
7	Center back door finisher	Chromium-plate	Cr	Cr	Cr	Cr	Cr	Cr	Cr	Cr	
8	Back door finisher	Chromium-plate	Cr	Cr	Cr	Cr	Cr	Cr	Cr	Cr	
9	Back door	Body color	BFAA	BKAG	BKH3	BK23	BK51	BK52	BL50	BQAA	
10	Door outside handle	Chromium-plate	Cr	Cr	Cr	Cr	Cr	Cr	Cr	Cr	

NOTE:

- S: Solid
- 2S: Solid + Clear

BODY EXTERIOR PAINT COLOR

< VEHICLE INFORMATION >

- CS: Color clear solid
- M: Metallic
- P: 2-Coat pearl
- 3P: 3-Coat pearl
- FPM: Iron oxide pearl
- RPM: Multi flex color
- TPM: Titanium pearl metallic
- TM: Micro titanium metallic
- PM: Pearl metallic

A

B

C

D

E

F

G

H

I

J

BRM

L

M

N

O

P

REPAIRING HIGH STRENGTH STEEL

< PRECAUTION >

PRECAUTION

REPAIRING HIGH STRENGTH STEEL

High Strength Steel (HSS)

INFOID:000000005172872

High strength steel is used for body panels in order to reduce vehicle weight.

Accordingly, precautions in repairing automotive bodies made of high strength steel are described below:

Tensile strength	Major applicable parts
370 - 590 MPa	<ul style="list-style-type: none"> • Front strut housing • Hoodledge reinforcement • Upper front hoodledge • Lower dash • Lower dash crossmember assembly • Front roof rail • Upper inner front pillar assembly • Inner center pillar • Inner sill • Upper & lower outer rear wheelhouse extension • Center front floor • Front floor (Component part) • Front & rear side member assembly • Front side member closing plate assembly • Front side member outrigger assembly • Front side member rear extension • Rear seat crossmember • Other reinforcements
780 - 1350 MPa	<ul style="list-style-type: none"> • Center pillar reinforcement (Component part) • Inner center pillar (Component part) • Outer side roof rail reinforcement • Outer sill reinforcement (Component part)

Read the following precautions when repairing HSS:

1. Additional points to consider

- The repair of reinforcements (such as side members) by heating is not recommended because it may weaken the component. When heating is unavoidable, never heat HSS parts above 550°C (1,022°F).

Verify heating temperature with a thermometer.

(Crayon-type and other similar type thermometer are appropriate.)

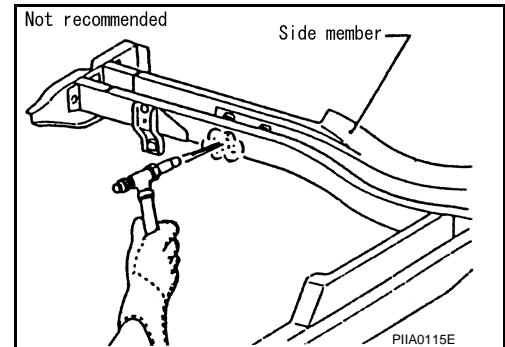

REPAIRING HIGH STRENGTH STEEL

< PRECAUTION >

- When straightening body panels, use caution in pulling any HSS panel. Because HSS is very strong, pulling may cause deformation in adjacent sections of the body. In this case, increase the number of measuring points, and carefully pull the HSS panel.

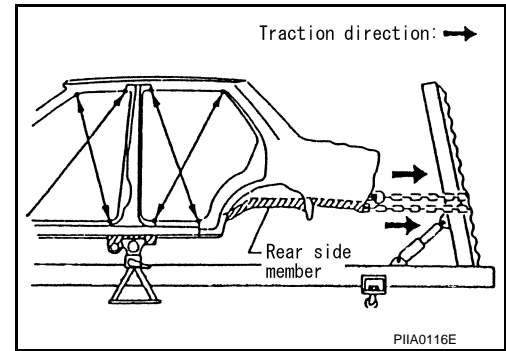

- When cutting HSS panels, avoid gas (torch) cutting if possible. Instead, use a saw to avoid weakening surrounding areas due to heat. If gas (torch) cutting is unavoidable, allow a minimum margin of 50 mm (1.97 in).

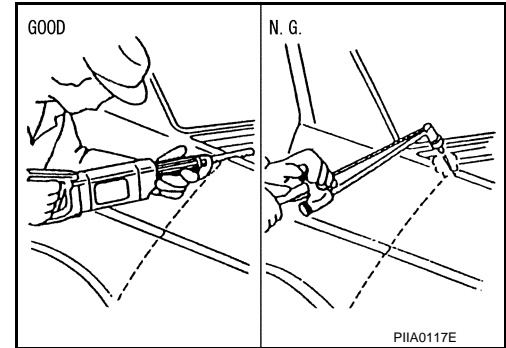

- When welding HSS panels, use spot welding whenever possible in order to minimize weakening surrounding areas due to heat. If spot welding is impossible, use MIG. welding. Do not use gas (torch) for welding because it is inferior in welding strength.

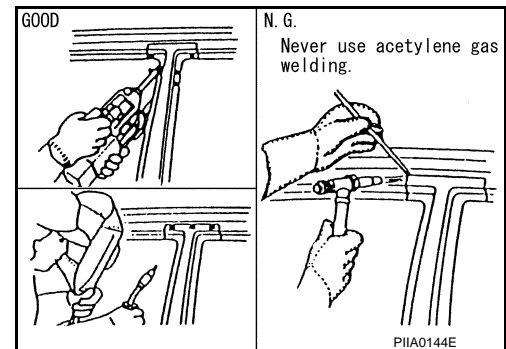

- Spot welding on HSS panels is harder than that of an ordinary steel panel. Therefore, when cutting spot welds on a HSS panel, use a low speed high torque drill (1,000 to 1,200 rpm) to increase drill bit durability and facilitate the operation.

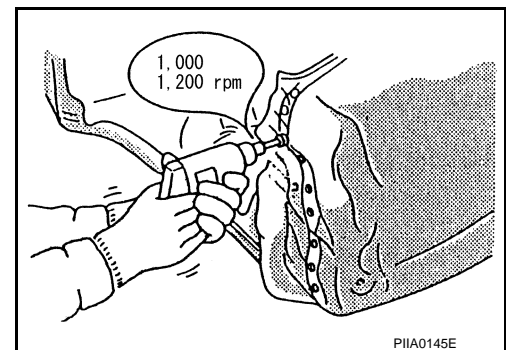

A
B
C
D
E
F
G
H
I
J
BRM
L
M
N
O
P

REPAIRING HIGH STRENGTH STEEL

< PRECAUTION >

2. Precautions in spot welding HSS

This work should be performed under standard working conditions. Always note the following when spot welding HSS:

- The electrode tip diameter must be sized properly according to the metal thickness.

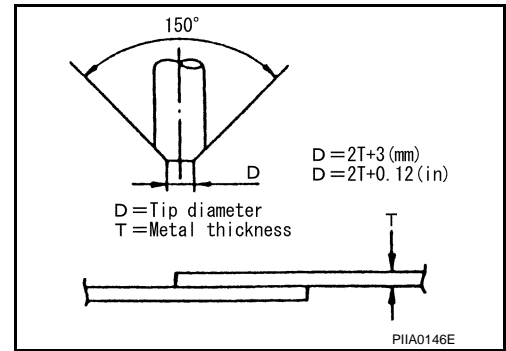

- The panel surfaces must fit flush to each other, leaving no gaps.

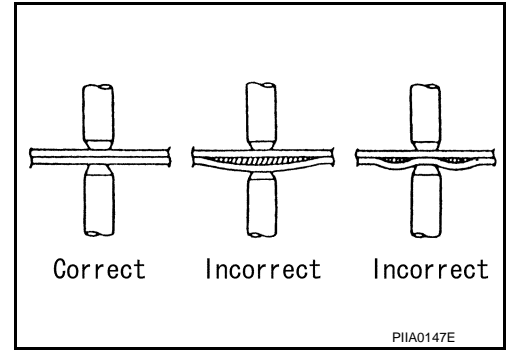

- Follow the specifications for the proper welding pitch.

Unit: mm (in)

Thickness (T)	Minimum pitch (L)
0.6 (0.024)	10 (0.39) or more
0.8 (0.031)	12 (0.47) or more
1.0 (0.039)	18 (0.71) or more
1.2 (0.047)	20 (0.79) or more
1.6 (0.063)	27 (1.06) or more
1.8 (0.071)	31 (1.22) or more

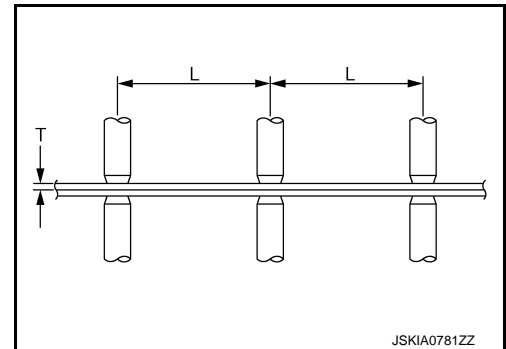

REPAIRING MATERIAL

< PREPARATION >

PREPARATION

REPAIRING MATERIAL

Foam Repair

INFOID:000000005172873

During factory body assembly, foam insulators are installed in certain body panels and locations around the vehicle. Use the following procedure(s) to replace any factory-installed foam insulators.

URETHANE FOAM APPLICATIONS

Use commercially available Urethane foam for sealant (foam material) repair of material used on vehicle.

<Urethane foam for foaming agent>

3M™ Automix™ Flexible Foam 08463 or equivalent

Read instructions on product for fill procedures.

Example of foaming agent filling operation procedure

1. Fill procedures after installation of service part.
 - a. Eliminate foam material remaining on vehicle side.
 - b. Clean area after eliminating form insulator and foam material.
 - c. Install service part.
 - d. Insert nozzle into hole near fill area and fill foam material or fill enough to close gap with the service part.

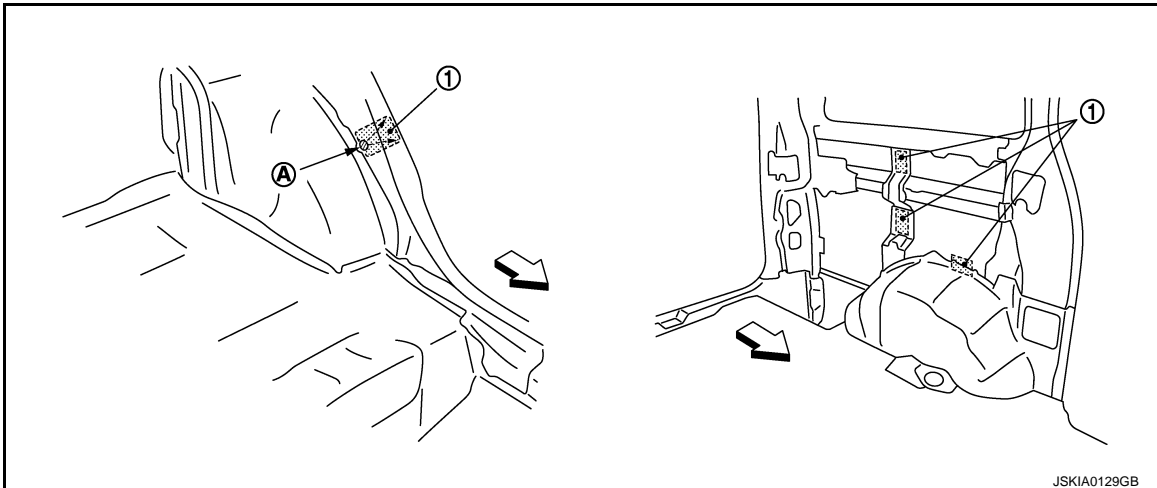

1. Urethane foam
- A. Nozzle insert hole

↔: Vehicle front

2. Fill procedures before installation of service part.
 - a. Eliminate foam material remaining on vehicle side.
 - b. Clean area after eliminating foam insulator and foam material.
 - c. Fill foam material on wheelhouse outer side.

REPAIRING MATERIAL

< PREPARATION >

- 1. Urethane foam
 - A. Fill while avoiding flange area
- ← Vehicle front

NOTE:

Fill enough to close gap with service part while avoiding flange area.

- d. Install service part.

NOTE:

Refer to label for information on working times.

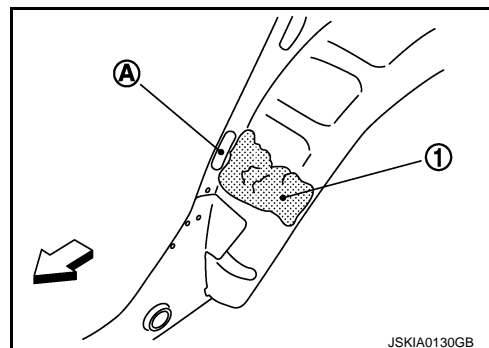

BODY COMPONENT PARTS

< PREPARATION >

BODY COMPONENT PARTS

Underbody Component Parts

INFOID:000000005172874



A
B
C
D
E
F
G
H
I
J
K
L
M
N
O
P

BRM

- | | | |
|---|-----------------------------------|--------------------------------------|
| 1. Radiator core support assembly (RH & LH) | 2. Front strut housing (RH & LH) | 3. Lower rear hoodledge (RH & LH) |
| 4. Upper front hoodledge (RH & LH) | 5. Upper rear hoodledge (RH & LH) | 6. Hoodledge reinforcement (RH & LH) |

JSKIA1061ZZ

BODY COMPONENT PARTS

< PREPARATION >

- | | | |
|---|--|--|
| 7. Upper side cowl top (RH & LH) | 8. Upper front cowl top assembly | 9. Cowl top bracket (RH & LH) |
| 10. Upper dash | 11. Lower dash crossmember assembly | 12. Lower outer battery support bracket |
| 13. Lower battery support bracket | 14. Lower dash | 15. Center front floor |
| 16. Front floor (RH & LH) | 17. Inner sill (RH & LH) | 18. Rear seat crossmember reinforcement assembly |
| 19. Rear floor front | 20. Rear floor seat belt anchor reinforcement | 21. Rear floor rear |
| 22. Spare tire clamp bracket | 23. Rear floor side (RH & LH) | 24. Front side member assembly (RH & LH) |
| 25. Front side member front extension (RH & LH) | 26. Front side member connector assembly (RH & LH) | 27. Front side member closing plate assembly (RH & LH) |
| 28. Front side member front closing plate (RH & LH) | 29. Front side member center closing plate (RH & LH) | 30. Front side member rear extension (RH & LH) |
| 31. Front side member outrigger assembly (RH & LH) | 32. Rear seat crossmember | 33. 2nd rear crossmember |
| 34. Rear crossmember center assembly | 35. Rear side member assembly (RH & LH) | 36. Rear side member extension (RH & LH) |
| 37. Rear end crossmember assembly | 38. Front side rear closing reinforcement (RH & LH) | |

 Both sided anti-corrosive precoated steel sections

 High strength steel (HSS) sections

 Both sided anti-corrosive steel and HSS sections

NOTE:

For the parts without a number described in the figure, it is supplied only with the assembly part that the part is included with.

BODY COMPONENT PARTS

< PREPARATION >

Body Component Parts

INFOID:000000005172875

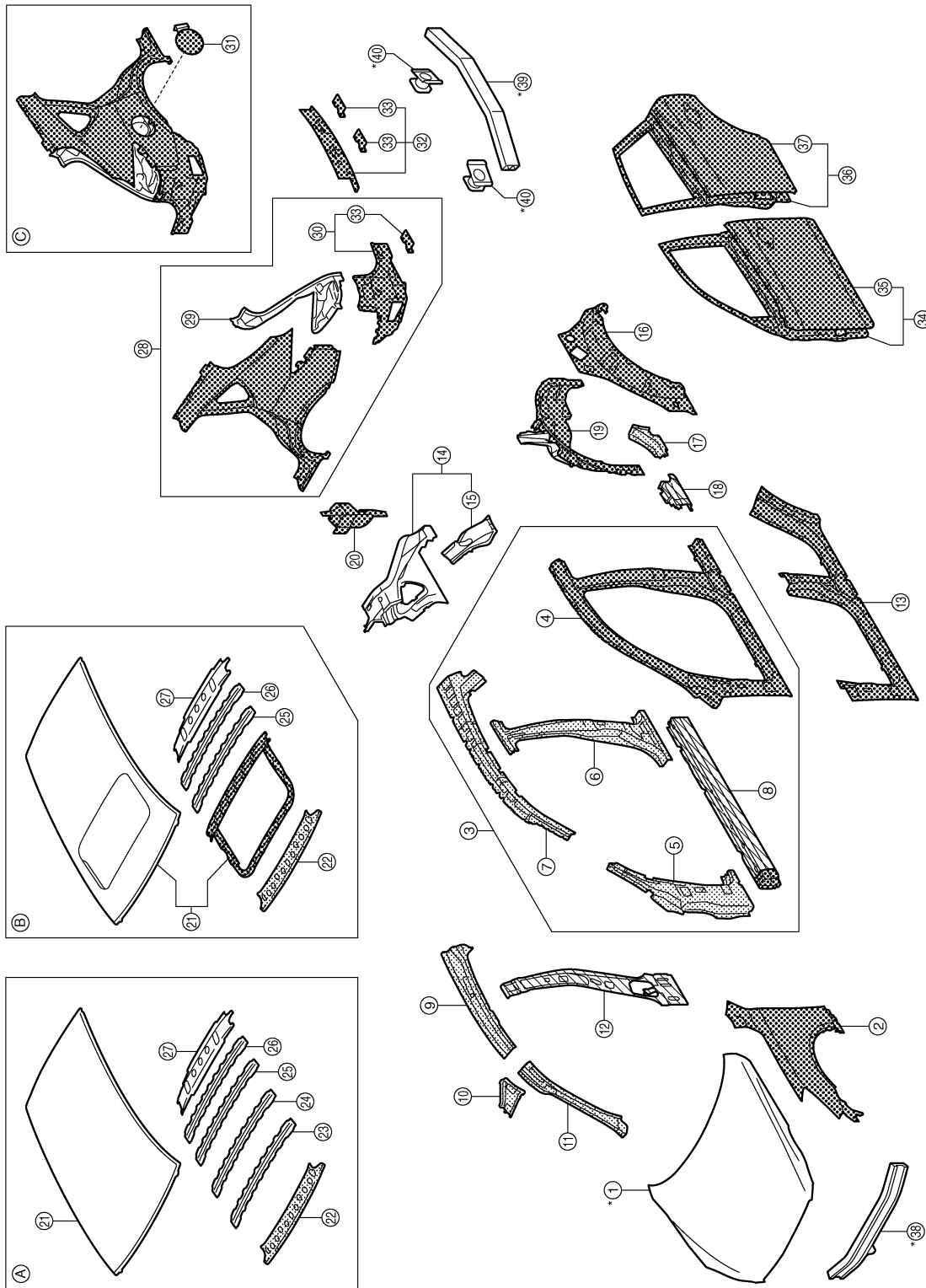

A
B
C
D
E
F
G
H
I
J
K
L
M
N
O
P

BRM

- | | | |
|---|---------------------------------------|--|
| 1. Hood | 2. Front fender (RH & LH) | 3. Side body assembly (RH & LH) |
| 4. Outer front side body (RH & LH) | 5. Front pillar brace (RH & LH) | 6. Center pillar reinforcement (RH & LH) |
| 7. Outer side roof rail reinforcement (RH & LH) | 8. Outer sill reinforcement (RH & LH) | 9. Inner roof rail reinforcement (RH & LH) |

JSKIA0582ZZ

BODY COMPONENT PARTS

< PREPARATION >

- | | | |
|-------------------------------------|---|---|
| 10. Front roof rail brace (RH & LH) | 11. Upper inner front pillar assembly (RH & LH) | 12. Inner center pillar (RH & LH) |
| 13. Outer sill (RH & LH) | 14. Inner rear pillar (RH & LH) | 15. Inner rear pillar reinforcement (RH & LH) |
| 16. Outer rear wheelhouse (RH & LH) | 17. Upper outer rear wheelhouse extension (RH & LH) | 18. Lower outer rear wheelhouse extension (RH & LH) |
| 19. Inner rear wheelhouse (RH & LH) | 20. Lower inner rear pillar (RH & LH) | 21. Roof |
| 22. Front roof rail | 23. Roof bow No. 1 | 24. Roof bow No. 2 |
| 25. Roof bow No. 3 | 26. Roof bow No. 4 | 27. Rear roof rail |
| 28. Rear fender assembly (RH & LH) | 29. Tail pillar assembly (RH & LH) | 30. Rear fender extension (RH & LH) |
| 31. Fuel filler lid | 32. Rear panel assembly | 33. Upper rear bumper retainer |
| 34. Front door assembly (RH & LH) | 35. Outer front door panel (RH & LH) | 36. Rear door assembly (RH & LH) |
| 37. Outer rear door panel (RH & LH) | 38. Inner center front bumper reinforcement | 39. Inner center rear bumper reinforcement assembly |
| 40. Rear bumper stay (RH & LH) | | |
| A. Standard roof | B. With sunroof | C. RH side |

 Both sided anti-corrosive precoated steel sections

 High strength steel (HSS) sections

 Both sided anti-corrosive steel and HSS sections

* : Aluminum portion

NOTE:

For the parts without a number described in the figure, it is supplied only with the assembly part that the part is included with.

CORROSION PROTECTION

< REMOVAL AND INSTALLATION >

REMOVAL AND INSTALLATION

CORROSION PROTECTION

Description

INFOID:000000005172885

To provide improved corrosion prevention, the following anti-corrosive measures have been implemented in NISSAN production plants. When repairing or replacing body panels, it is necessary to use the same anti-corrosive measures.

Anti-Corrosive Precoated Steel (Galvannealed Steel)

To improve repairability and corrosion resistance, a new type of anti-corrosive precoated steel sheet is adopted replacing conventional zinc-coated steel sheet.

Galvannealed steel is electroplated and heated to form Zinc-iron alloy, which provides excellent and long term corrosion resistance with cationic electrodeposition primer.

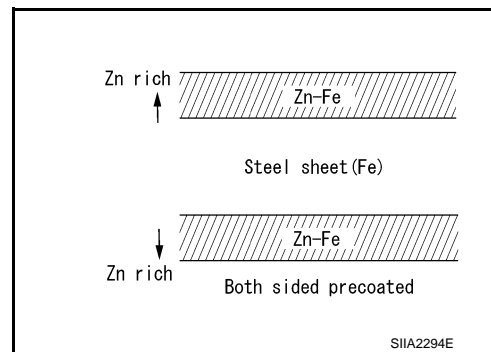

NISSAN genuine parts are fabricated from galvannealed steel. Therefore, it is recommended that NISSAN genuine parts or an equivalent be used for panel replacement to maintain the anti-corrosive performance built into the vehicle at the factory.

Phosphate Coating Treatment and Cationic Electrodeposition Primer

A phosphate coating treatment and a cationic electrodeposition primer, which provide excellent corrosion protection, are applied to all body components.

CAUTION:

Confine paint removal during welding operation to an absolute minimum.

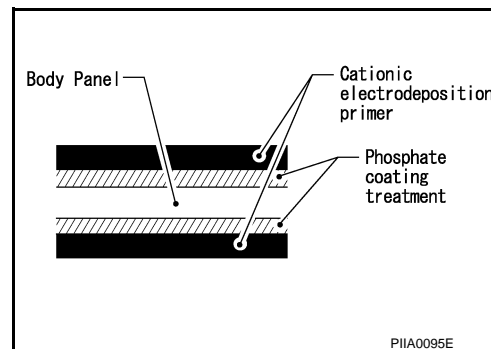

NISSAN genuine parts are also treated in the same manner. Therefore, it is recommended that NISSAN genuine parts or an equivalent be used for panel replacement to maintain anti-corrosive performance built into the vehicle at the factory.

Anti-corrosive Wax

INFOID:000000005172886

To improve corrosion resistance, anti-corrosive wax is applied inside the body sill and inside other closed sections. Accordingly, when replacing these parts, be sure to apply anti-corrosive wax to the appropriate areas of the new parts. Select an excellent anti-corrosive wax which will penetrate after application and has a long shelf life.

DOOR

CORROSION PROTECTION

< REMOVAL AND INSTALLATION >

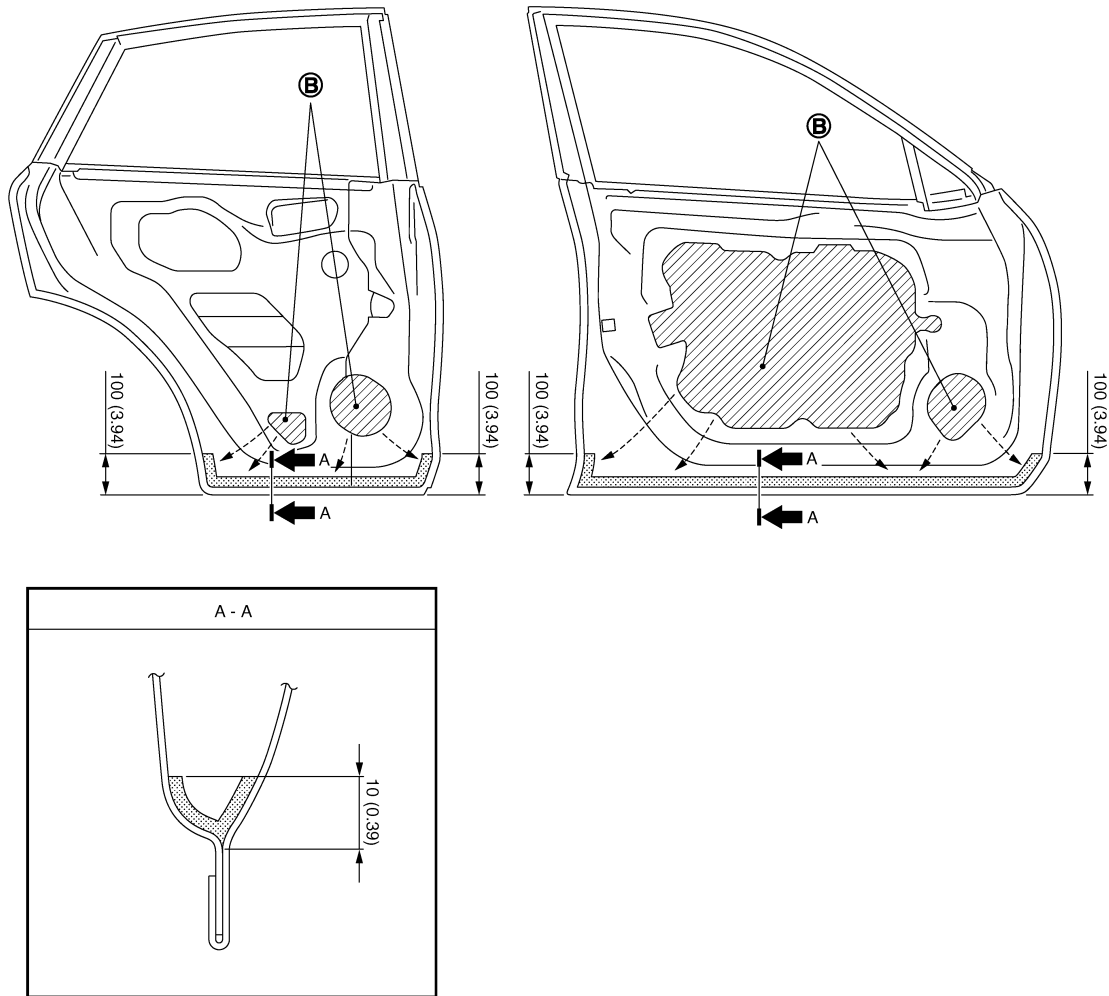

JSKIA0584GB

B. Nozzle insert hole

▨ : Anti-corrosive wax coated portions

Undercoating

INFOID:000000005172887

The underside of the floor and wheelhouse are undercoated to prevent rust, vibration, noise and stone chipping. Therefore, when such a panel is replaced or repaired, apply undercoating to that part. Use an undercoating which is rust resistant, soundproof, vibration-proof, shock-resistant, adhesive, and durable.

Precautions in Undercoating

1. Never apply undercoating to any place unless specified (such as the areas above the muffler and three way catalyst that are subjected to heat).
2. Never undercoat the exhaust pipe or other parts that become hot.
3. Never undercoat rotating parts.
4. Apply bitumen wax after applying undercoating.
5. After putting seal on the vehicle, put undercoating on it.

CORROSION PROTECTION

< REMOVAL AND INSTALLATION >

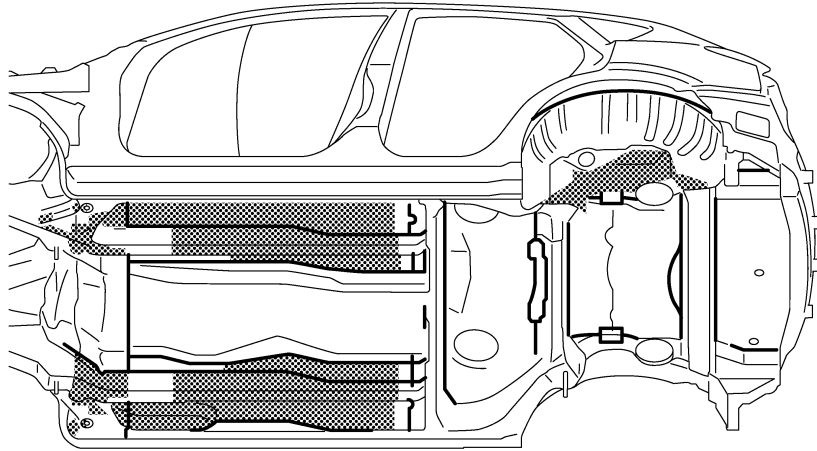

JSKIA1065ZZ

 Undercoated portions

 Sealed portions

Body Sealing

INFOID:000000005172888

The following figure shows the areas which are sealed at the factory. Sealant which has been applied to these areas should be smooth and free from cuts or gaps. Care should be taken not to apply an excess amount of sealant and not to allow other unaffected parts to come into contact with the sealant.

2WD

A
B
C
D
E
F
G
H
I
J
L
M
N
O
P

BRM

CORROSION PROTECTION

< REMOVAL AND INSTALLATION >

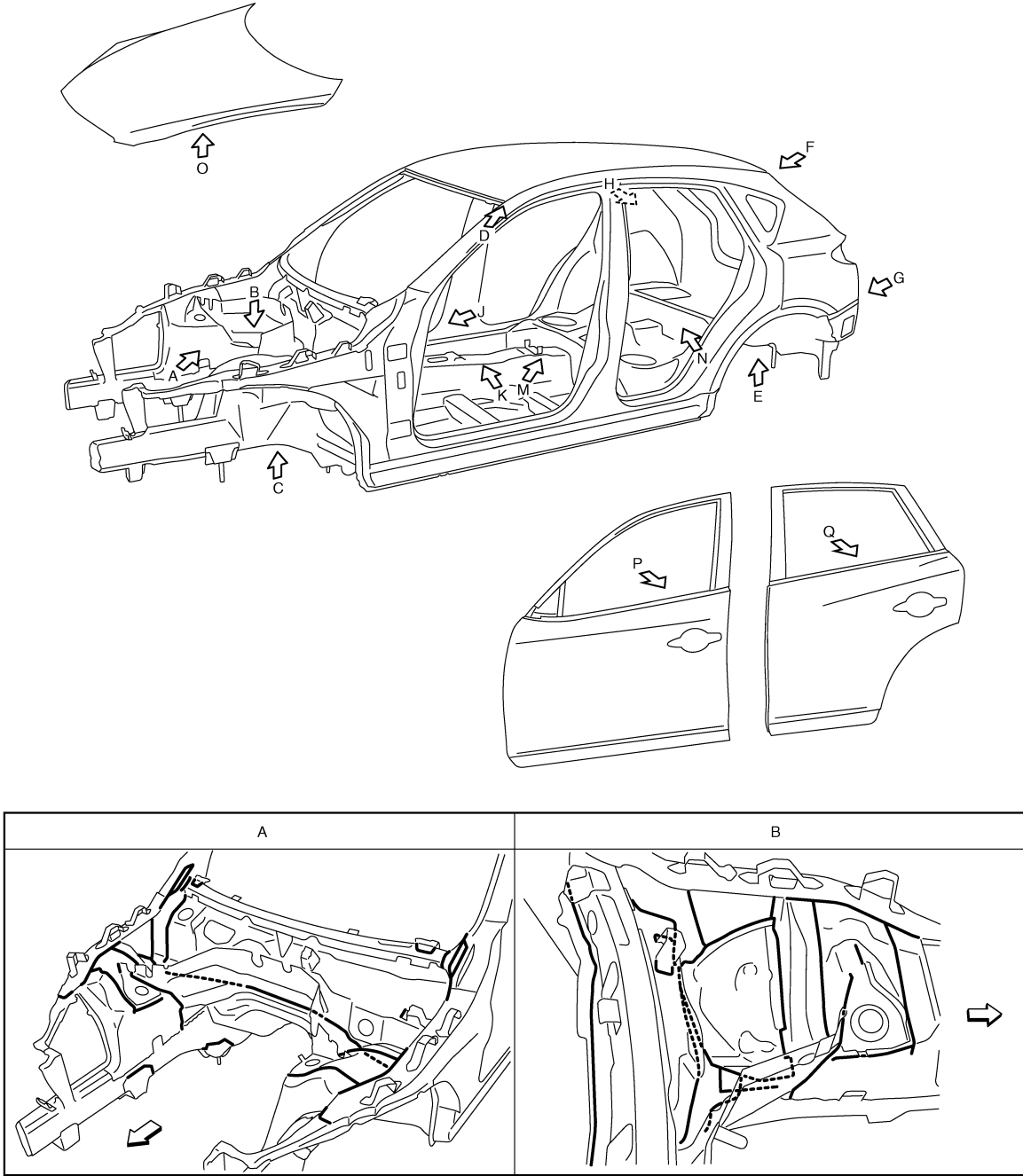

JSKIA0586ZZ

↔: Vehicle front

—: Sealed portions

CORROSION PROTECTION

< REMOVAL AND INSTALLATION >

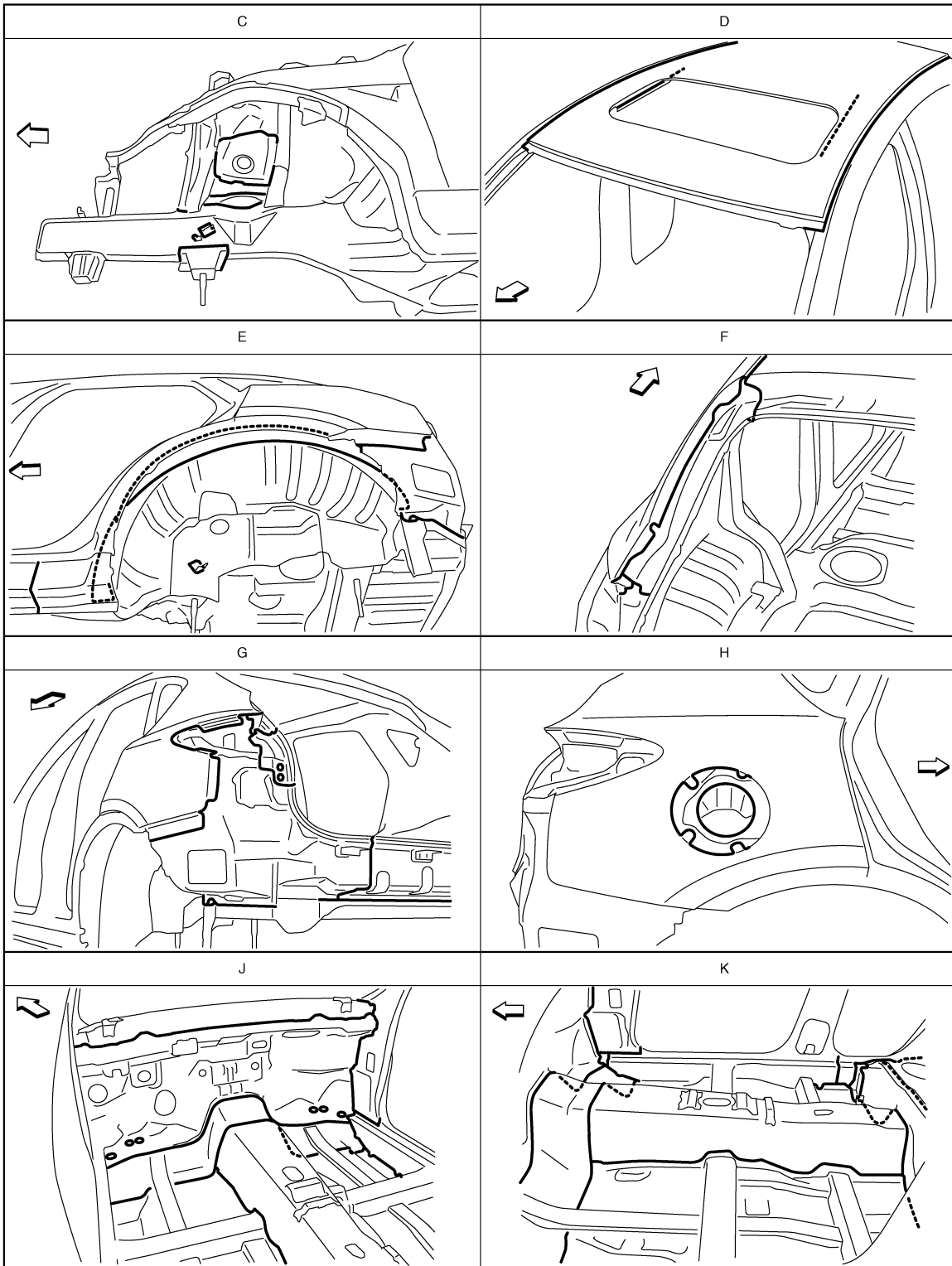

A
B
C
D
E
F
G
H
I
J
L
M
N
O
P

BRM

JSKIA0587ZZ

←: Vehicle front
—: Sealed portions

CORROSION PROTECTION

< REMOVAL AND INSTALLATION >

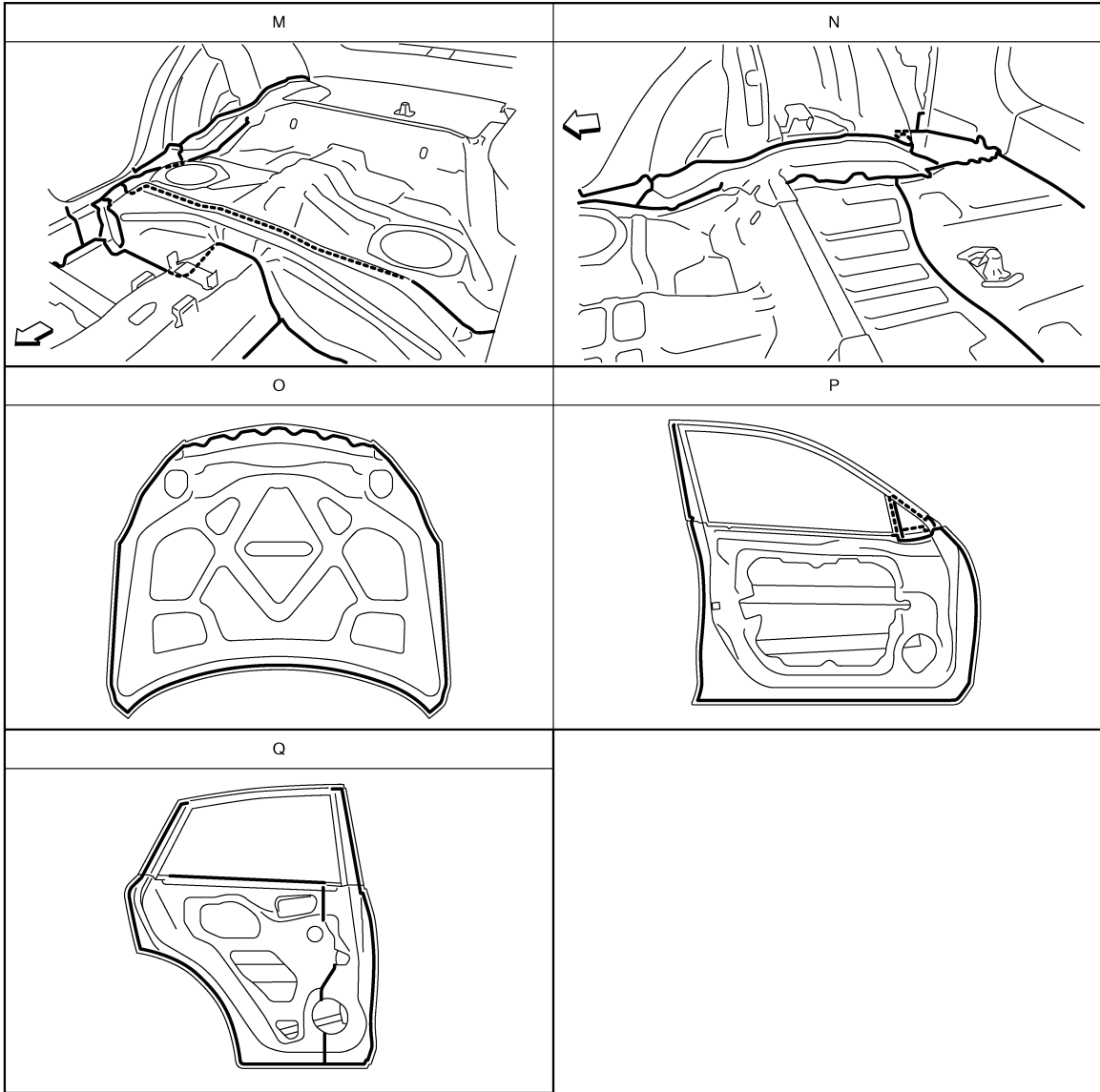

JSKIA0588ZZ

↩: Vehicle front

—: Sealed portions

AWD

CORROSION PROTECTION

< REMOVAL AND INSTALLATION >

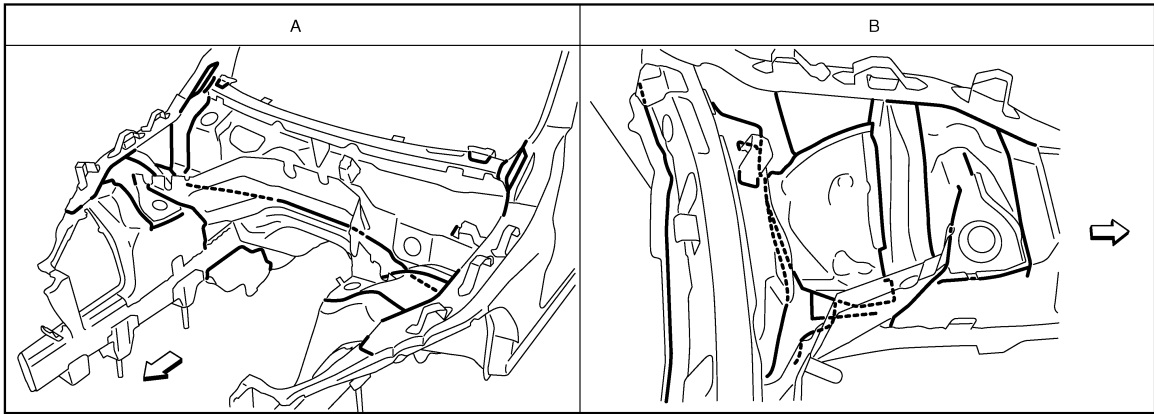
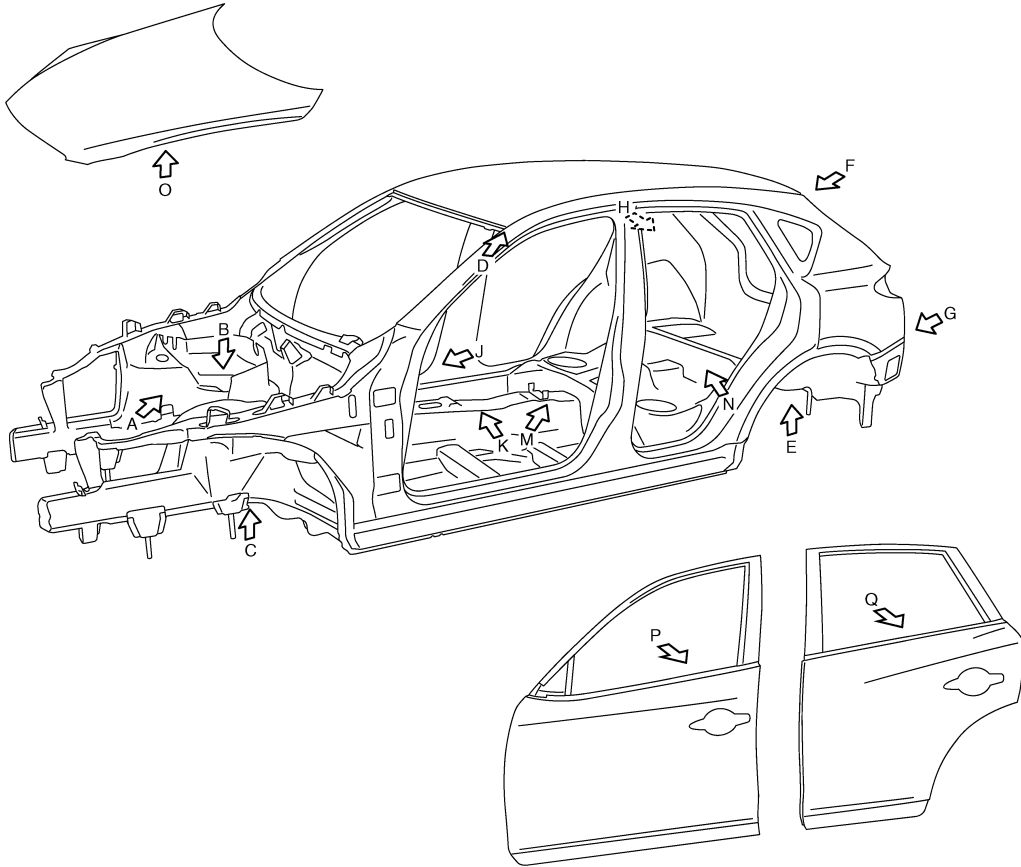

JSKIA0590ZZ

←: Vehicle front
 —: Sealed portions

A
B
C
D
E
F
G
H
I
J
L
M
N
O
P

BRM

CORROSION PROTECTION

< REMOVAL AND INSTALLATION >

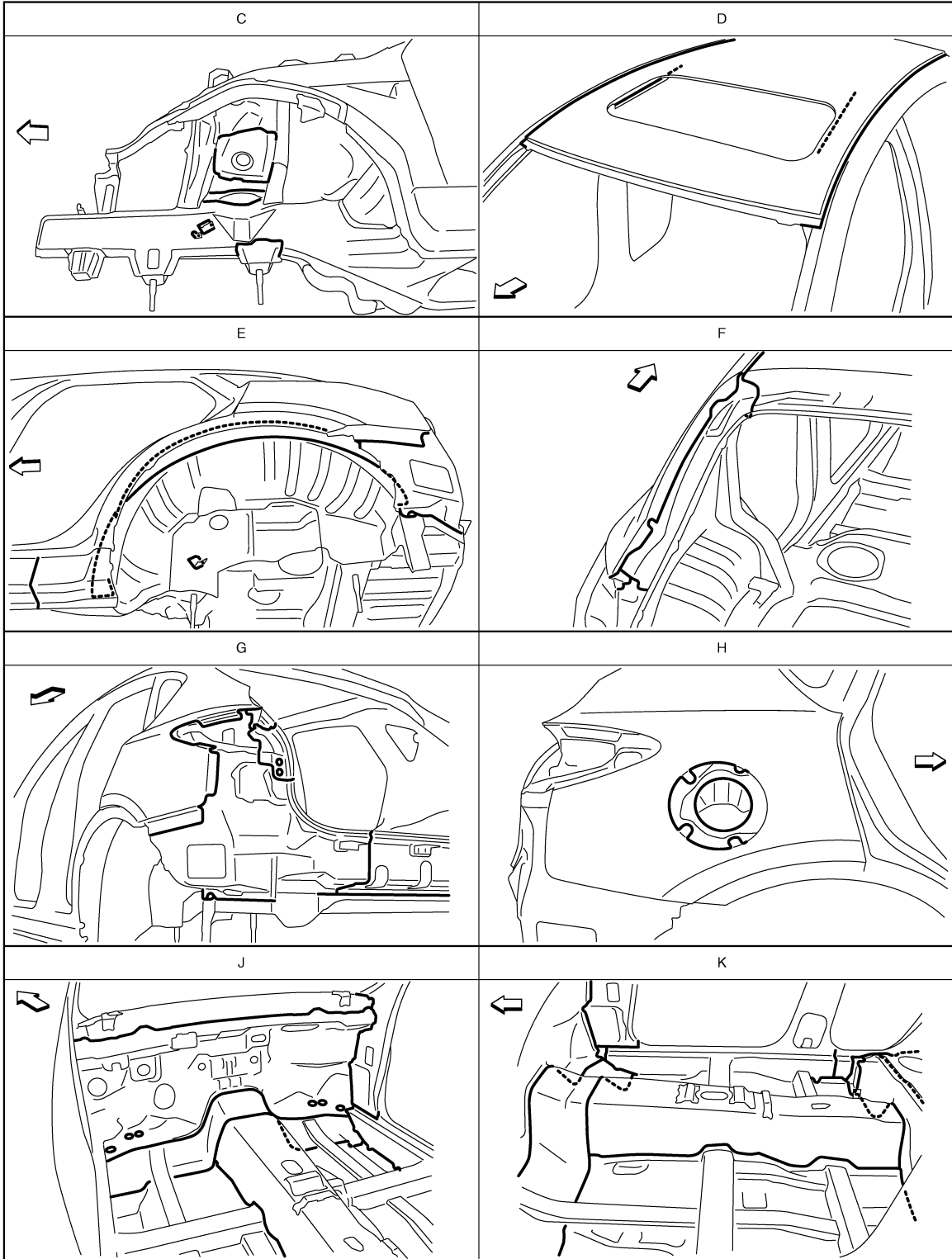

JSKIA0591ZZ

↶: Vehicle front

—: Sealed portions

CORROSION PROTECTION

< REMOVAL AND INSTALLATION >

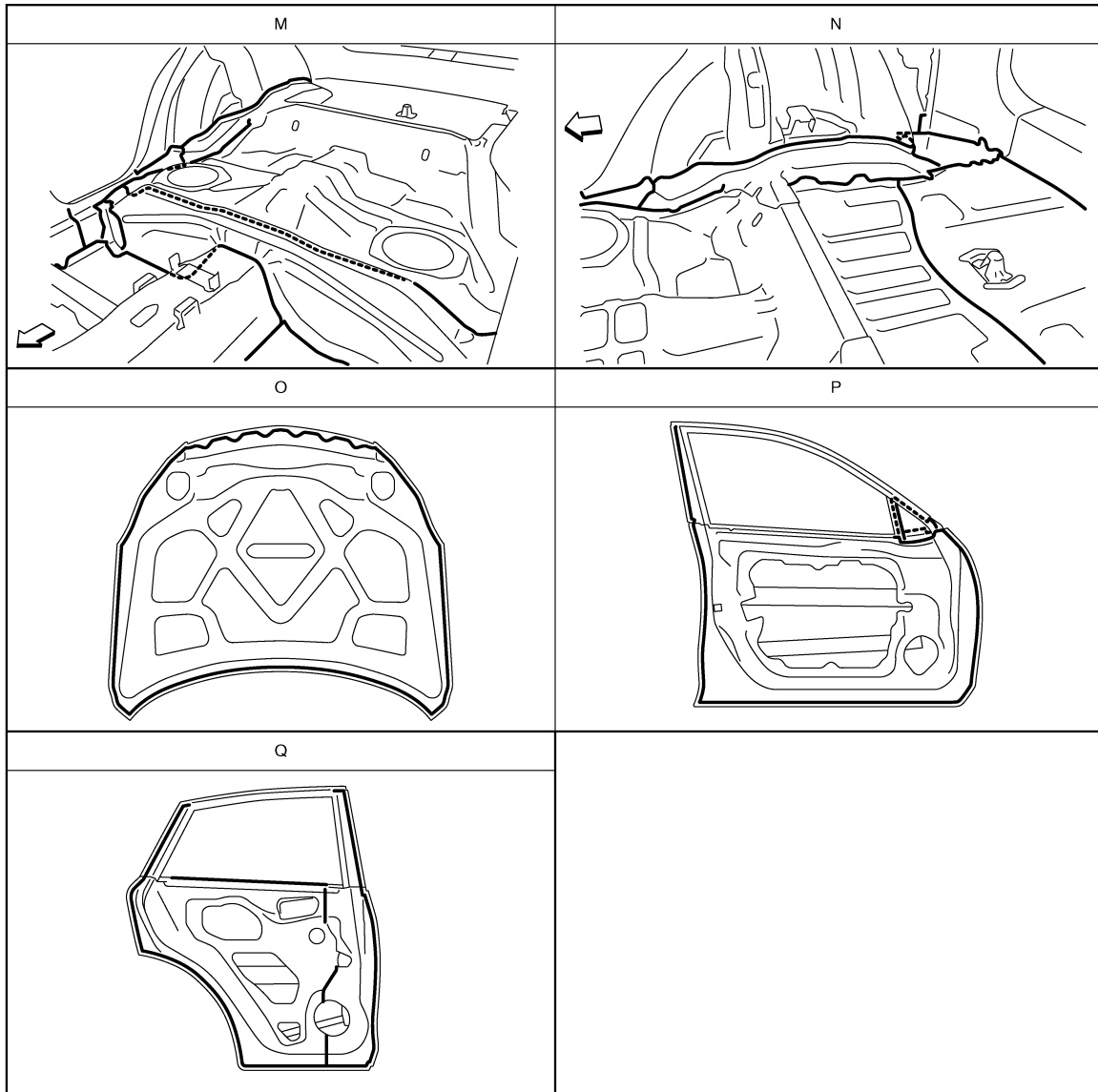

A
B
C
D
E
F
G
H
I
J
L
M
N
O
P

BRM

←: Vehicle front
—: Sealed portions

JSKIA0588ZZ

BODY CONSTRUCTION

< REMOVAL AND INSTALLATION >

BODY CONSTRUCTION

Body Construction

INFOID:000000005172889

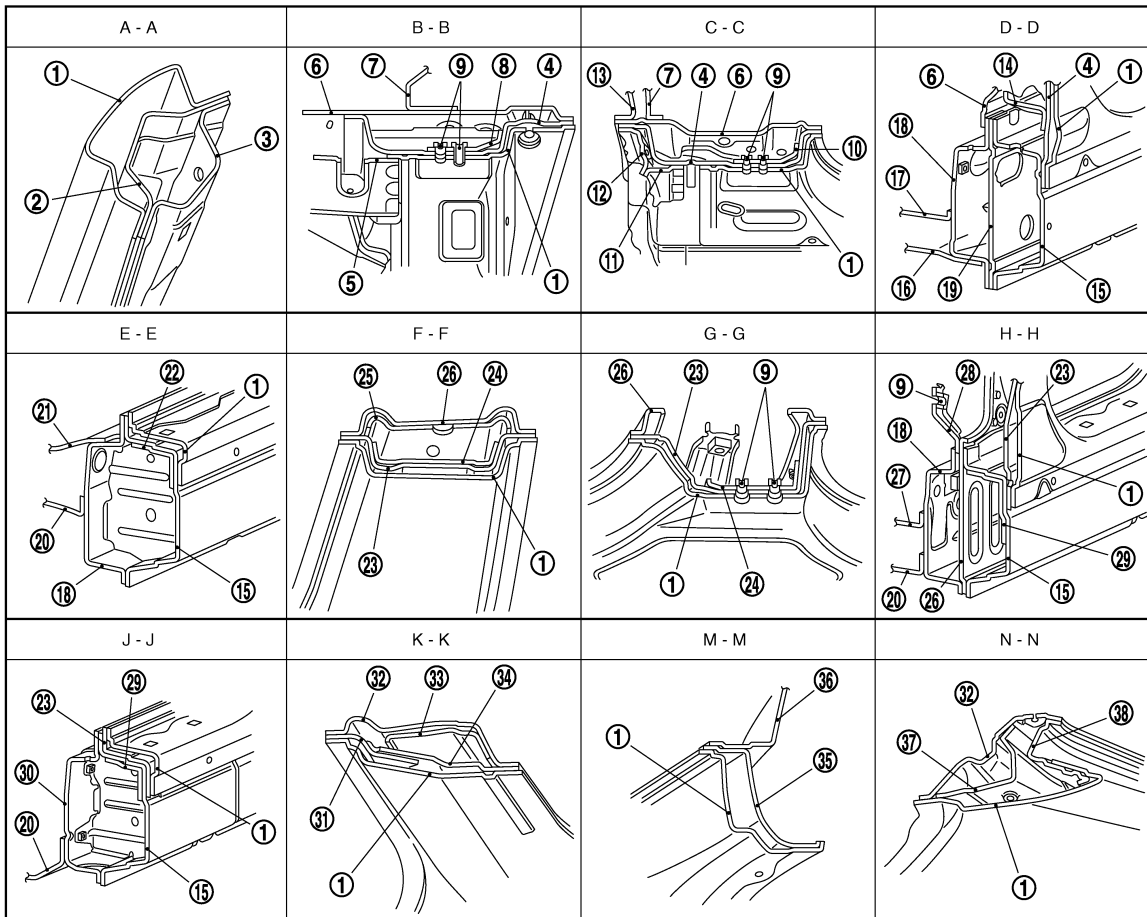
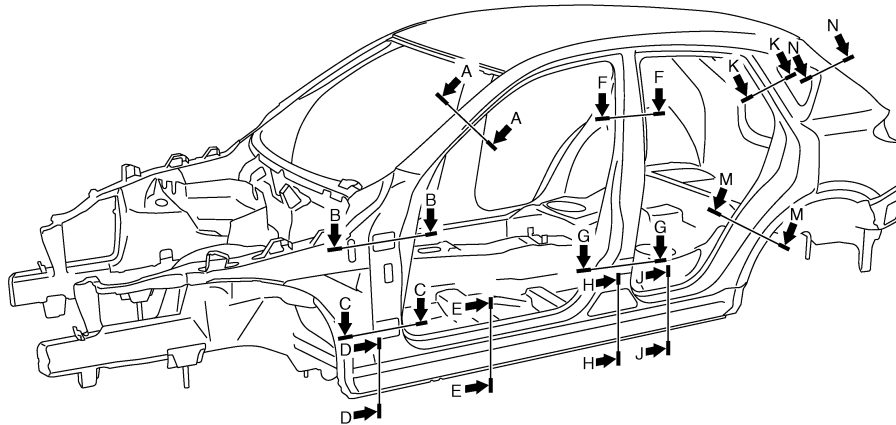

JSKIA0589ZZ

- | | | |
|-----------------------------|-------------------------------------|-----------------------------|
| 1. Outer side body | 2. Outer front pillar reinforcement | 3. Upper inner front pillar |
| 4. Front pillar hinge brace | 5. Hoodledge reinforcement | 6. Upper rear hoodledge |
| 7. Upper dash | 8. Upper hinge plate | 9. Weld nut |

BODY CONSTRUCTION

< REMOVAL AND INSTALLATION >

10. Lower hinge plate	11. Rear hoodledge reinforcement	12. Hoodledge reinforcement gusset	A
13. Lower dash crossmember	14. Lower front pillar gusset	15. Outer sill reinforcement	
16. Front side member outrigger	17. Lower dash	18. Inner sill	
19. Lower front pillar reinforcement	20. Front floor	21. Front floor gusset	B
22. Outer sill extension	23. Center pillar reinforcement	24. Center pillar seat belt reinforcement	
25. Center pillar seat belt anchor	26. Inner center pillar	27. 3rd crossmember	
28. Seat belt anchor	29. Center sill reinforcement	30. Rear side member front	C
31. Side roof rail reinforcement	32. Inner rear pillar	33. Upper rear pillar seat belt anchor	
34. Inner rear pillar reinforcement	35. Outer rear wheelhouse	36. Inner rear wheelhouse	D
37. Upper back pillar reinforcement	38. Back pillar main		

E

F

G

H

I

J

BRM

L

M

N

O

P

REPLACEMENT OPERATIONS

< REMOVAL AND INSTALLATION >





REPLACEMENT OPERATIONS

Description

INFOID:000000005172890

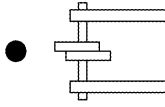
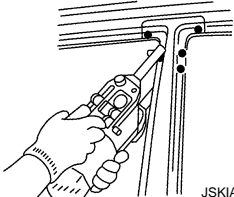
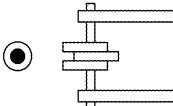
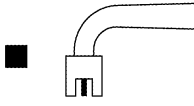
- This section is prepared for technicians who have attained a high level of skill and experience in repairing collision-damaged vehicles and also use modern service tools and equipment. Persons unfamiliar with body repair techniques should not attempt to repair collision-damaged vehicles by using this section.
- Technicians are also encouraged to read the Body Repair Manual (Fundamentals) in order to ensure that the original functions and quality of the vehicle are maintained. The Body Repair Manual (Fundamentals) contains additional information, including cautions and warnings, that are not including in this manual. Technicians should refer to both manuals to ensure proper repair.
- Please note that this information is prepared for worldwide usage, and as such, certain procedures might not apply in some regions or countries.

The symbols used in this section for welding operations are shown below.

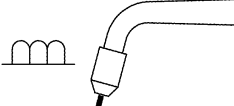
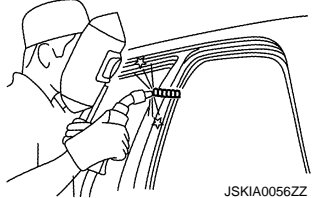
Symbol marks	Description	
 <p data-bbox="402 844 490 861">JSKIA0049ZZ</p>	2-spot welds	 <p data-bbox="1291 970 1377 987">JSKIA0053ZZ</p>
 <p data-bbox="402 1096 490 1113">JSKIA0050ZZ</p>	3-spot welds	
 <p data-bbox="402 1474 490 1491">JSKIA0051ZZ</p>	MIG plug weld	 <p data-bbox="1291 1348 1377 1365">JSKIA0054ZZ</p> <p data-bbox="1006 1381 1318 1407">For 3 panels plug weld method</p> <div style="display: flex; flex-direction: column; align-items: center;"> <div data-bbox="1144 1438 1307 1480"> <p data-bbox="1144 1449 1177 1470">■ A</p>  </div> <div data-bbox="1144 1533 1307 1575"> <p data-bbox="1144 1543 1177 1564">■ B</p>  </div> </div> <p data-bbox="1291 1600 1377 1617">JSKIA0055ZZ</p>
 <p data-bbox="402 1852 490 1869">JSKIA0052ZZ</p>	MIG seam weld / Point weld	 <p data-bbox="1291 1852 1377 1869">JSKIA0056ZZ</p>

REPLACEMENT OPERATIONS

< REMOVAL AND INSTALLATION >

- Front pillar butt joint can be determined anywhere within shaded area as shown in the figure. The best location for the butt joint is at position A due to the construction of the vehicle.

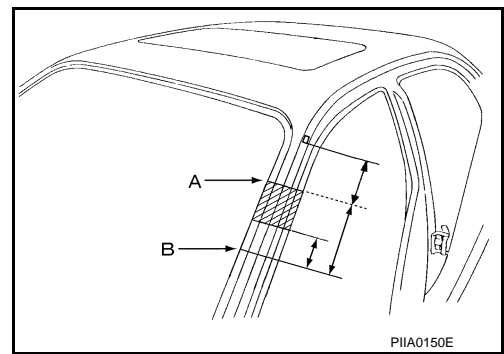

- Determine cutting position and record distance from the locating indent. Use this distance when cutting the service part. Cut outer front pillar over 60 mm (2.36 in) above the inner front pillar cut position.

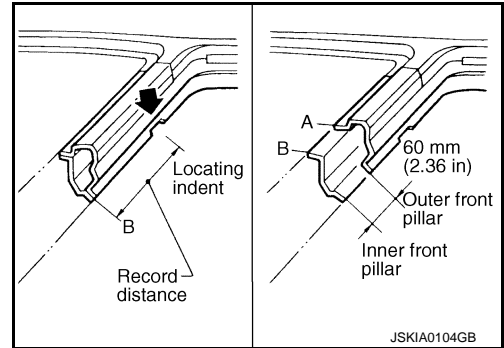

- Prepare a cutting jig to make outer pillar easier to cut. Also, this will permit the service part to be accurately cut at the joint position.

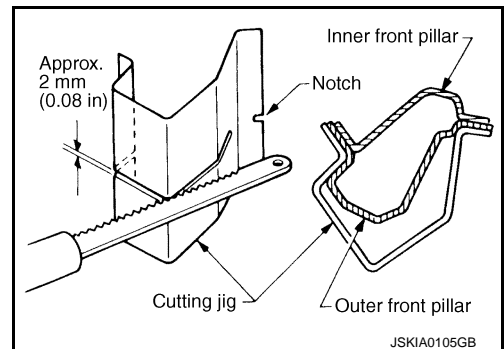

- An example of cutting operation using a cutting jig is as per the following.

1. Mark cutting lines.
A: Cut position of outer pillar
B: Cut position of inner pillar
2. Align cutting line with notch on jig. Clamp jig to pillar.
3. Cut outer pillar along groove of jig (at position A).
4. Remove jig and cut remaining portions.
5. Cut inner pillar at position B in same manner.

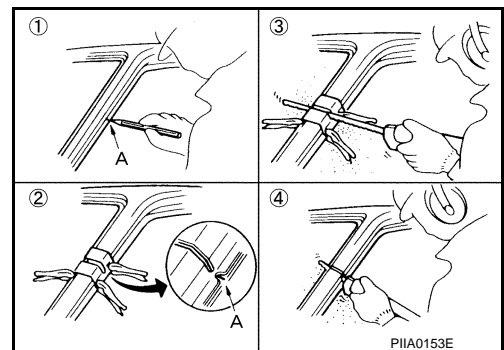

A
B
C
D
E
F
G
H
I
J
L
M
N
O
P

BRM

REPLACEMENT OPERATIONS

< REMOVAL AND INSTALLATION >

Radiator Core Support

INFOID:000000005172891

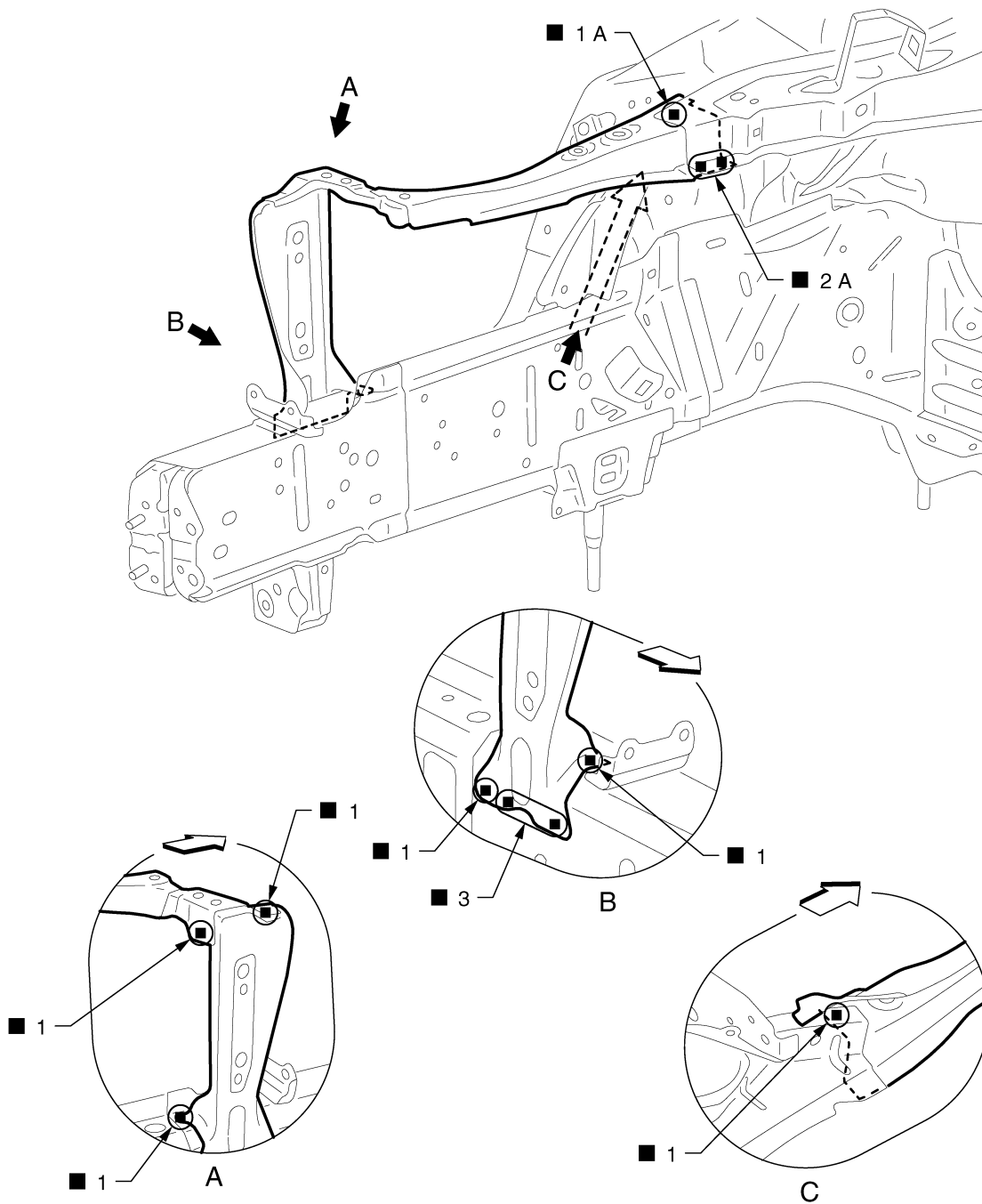

JSKIA0592ZZ

←: Vehicle front

Replacement parts

- Radiator core support assembly (LH)
- Front side member connector assembly (LH)

Hoodledge

INFOID:000000005172892

Work after radiator core support is removed.
Remove the front side member center closing plate (reusable).

REPLACEMENT OPERATIONS

< REMOVAL AND INSTALLATION >

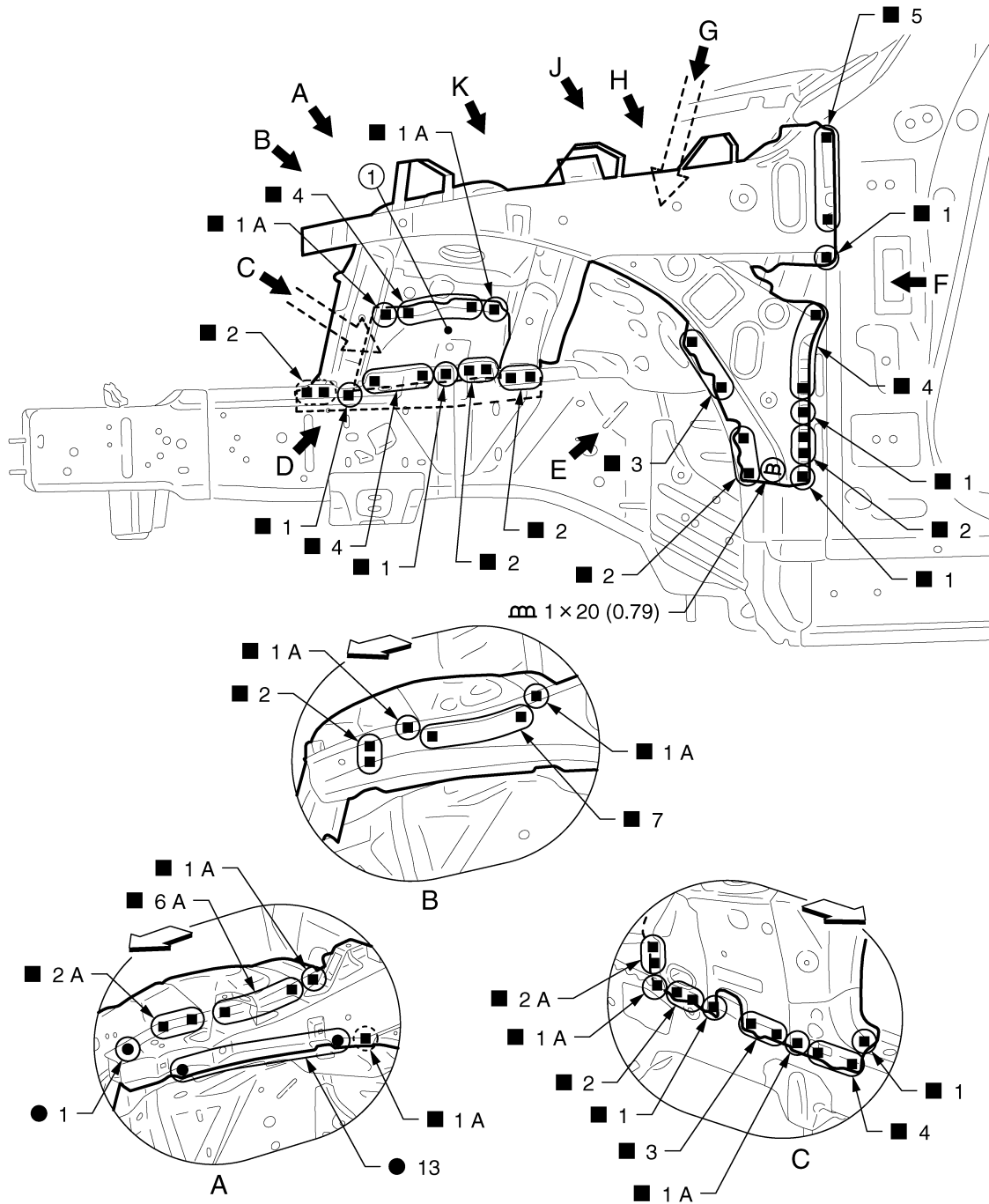

JSKIA0593GB

1. Front side member center closing plate

Unit: mm (in)

← Vehicle front

Replacement parts

- Upper front hoodledge (LH)
- Hoodledge reinforcement (LH)
- Front strut housing (LH)

View B: Before installing hoodledge reinforcement

REPLACEMENT OPERATIONS

< REMOVAL AND INSTALLATION >

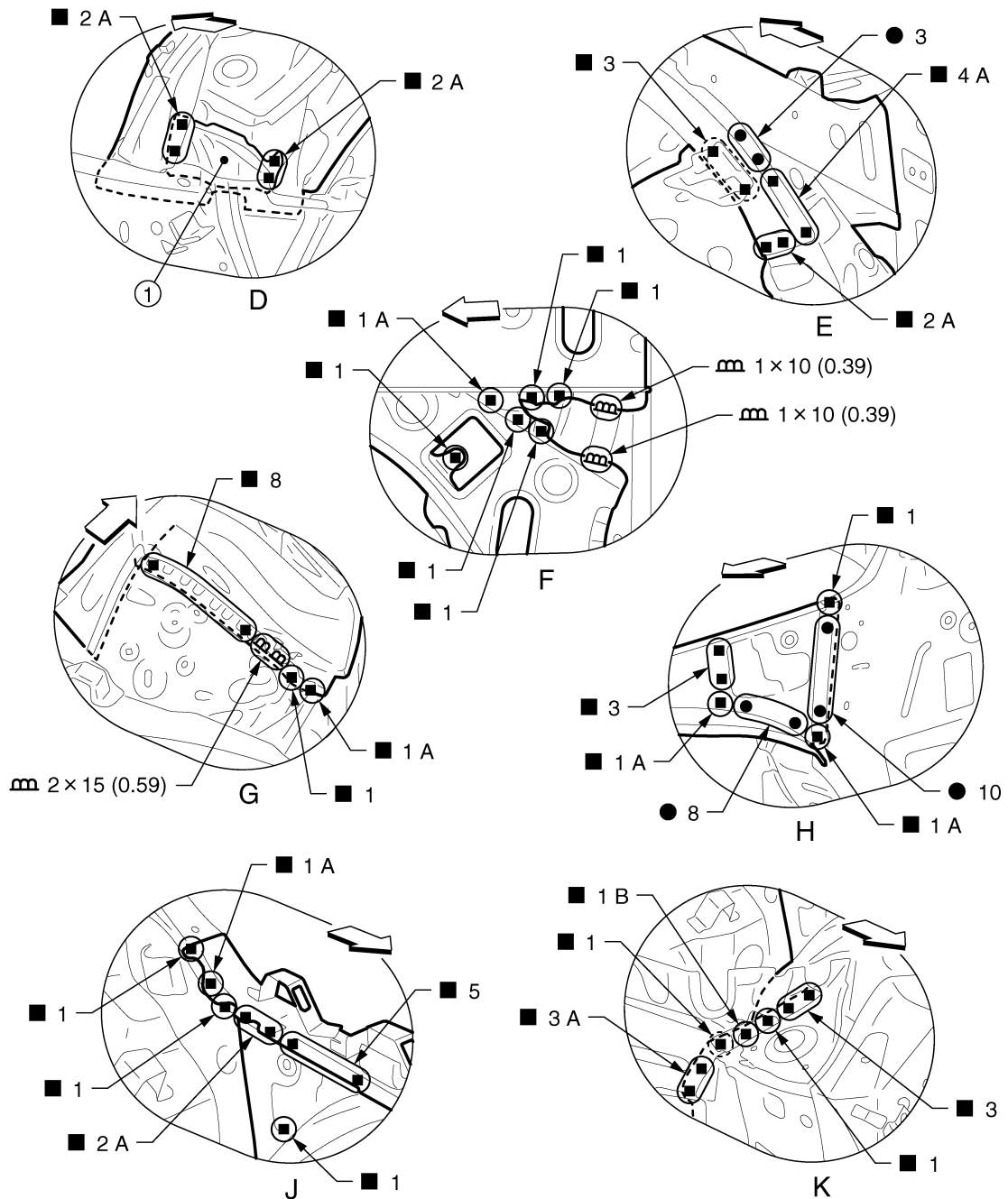

JSKIA0594GB

1. Front side member center closing plate

Unit: mm (in)

↔: Vehicle front

View H: Before installing hoodledge reinforcement

Front Side Member (2WD)

INFOID:000000005172893

Work after radiator core support and hoodledge are removed.
Assemble the hoodledge and check the fitting according to Body Alignment before replacing the front side member center closing plate.

REPLACEMENT OPERATIONS

< REMOVAL AND INSTALLATION >

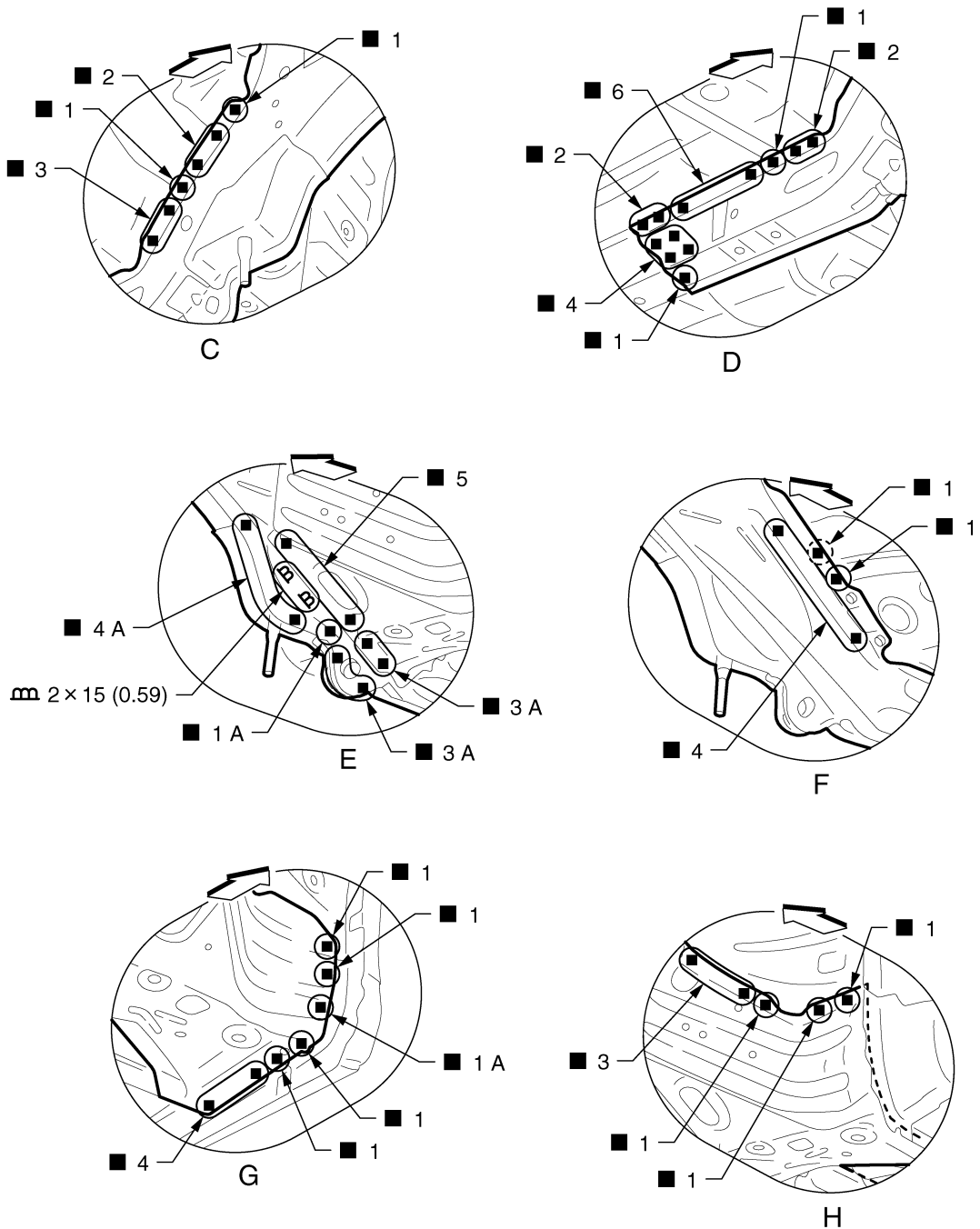

JSKIA0596GB

Unit: mm (in)
 ⇐ Vehicle front

View F: Before installing front side member outrigger assembly

REPLACEMENT OPERATIONS

< REMOVAL AND INSTALLATION >

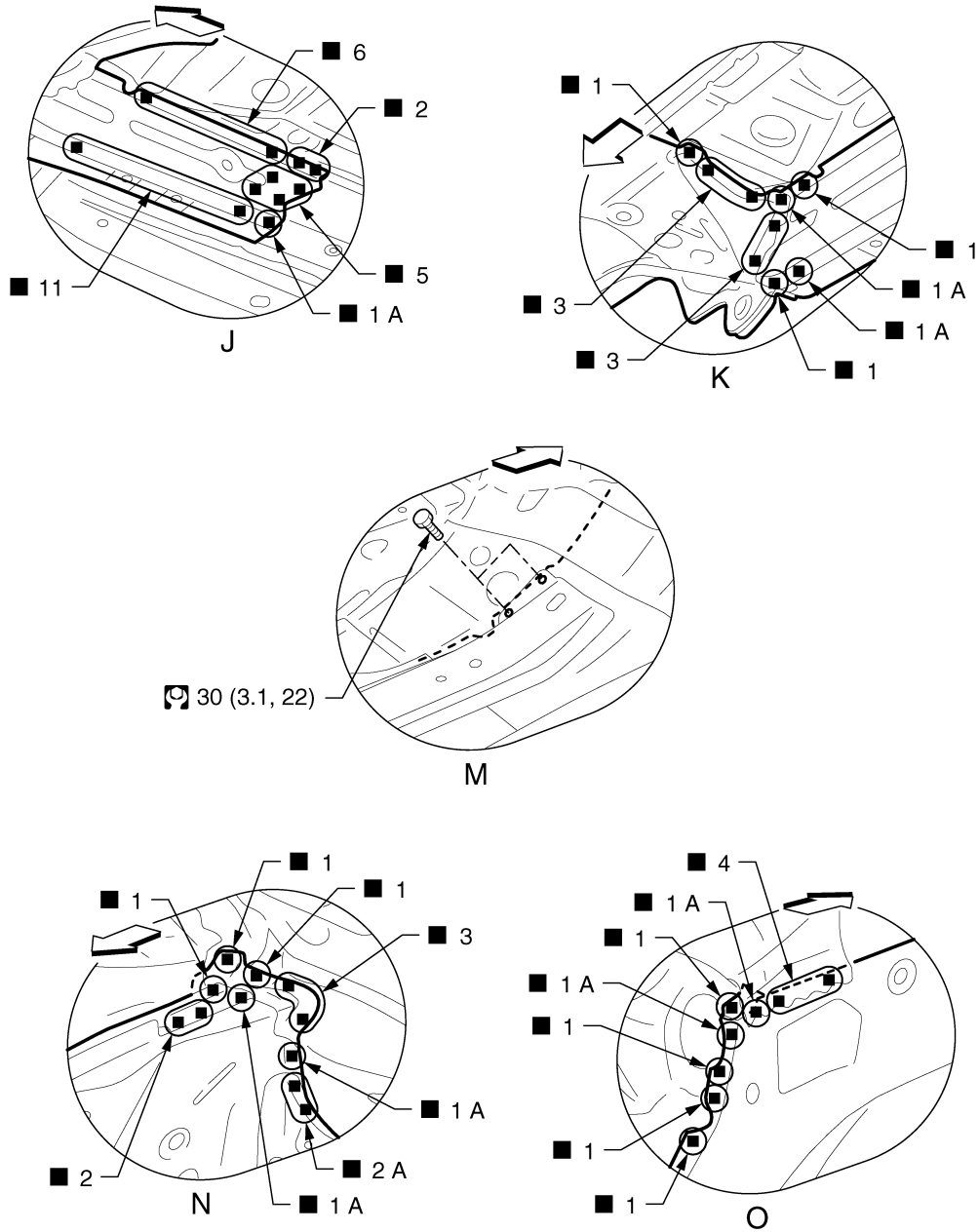

←: Vehicle front

Refer to [GI-4, "Components"](#) for symbols in the figure.

Front Side Member (AWD)

INFOID:000000005172894

Work after radiator core support and hoodledge are removed.
 Assemble the hoodledge and check the fitting according to Body Alignment before replacing the front side member center closing plate.

A
B
C
D
E
F
G
H
I
J
K
L
M
N
O
P

BRM

REPLACEMENT OPERATIONS

< REMOVAL AND INSTALLATION >

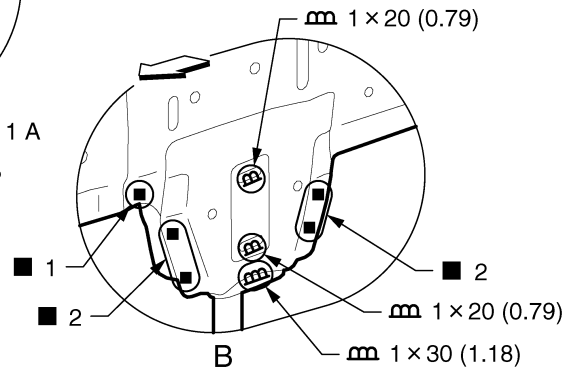
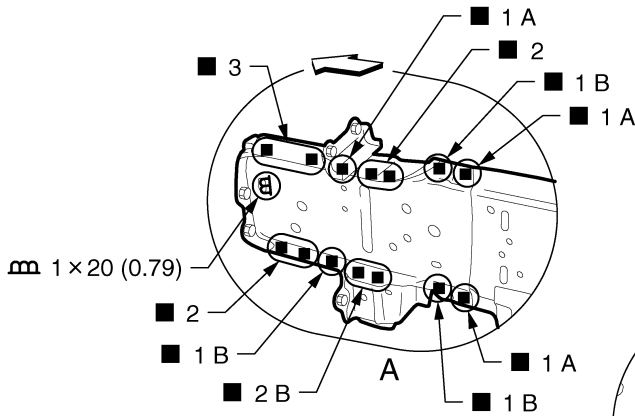
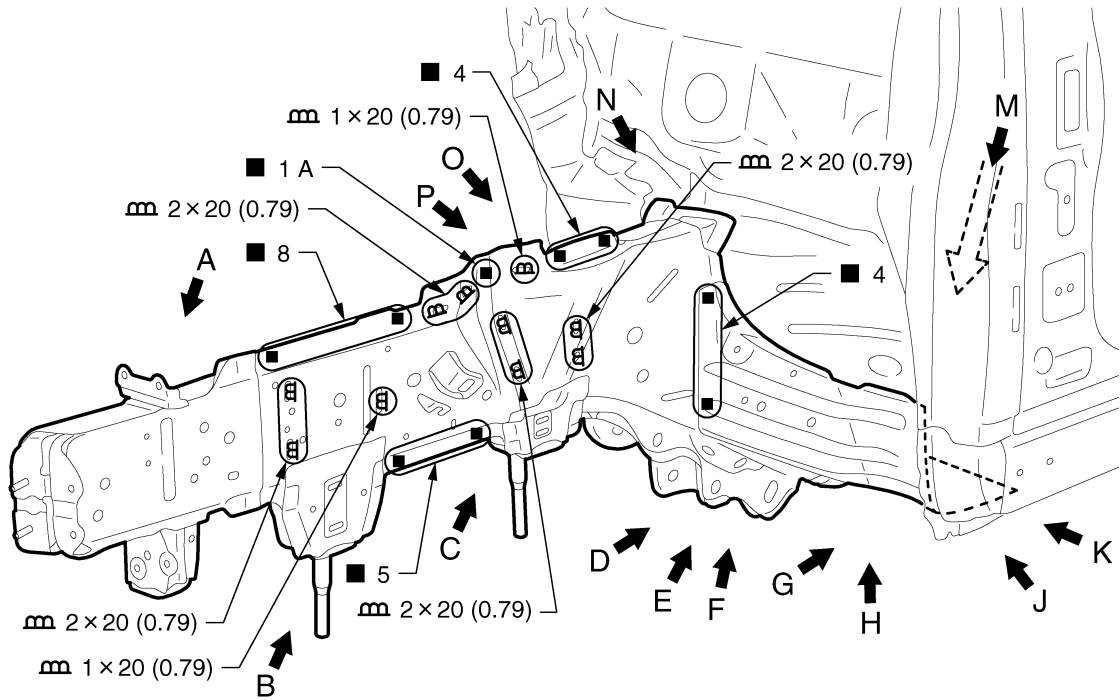

JSKIA0598GB

Unit: mm (in)

◀: Vehicle front

Replacement parts

- Front side member assembly (LH)
- Front side member closing plate assembly (LH)
- Front side member outrigger assembly (LH)

REPLACEMENT OPERATIONS

< REMOVAL AND INSTALLATION >

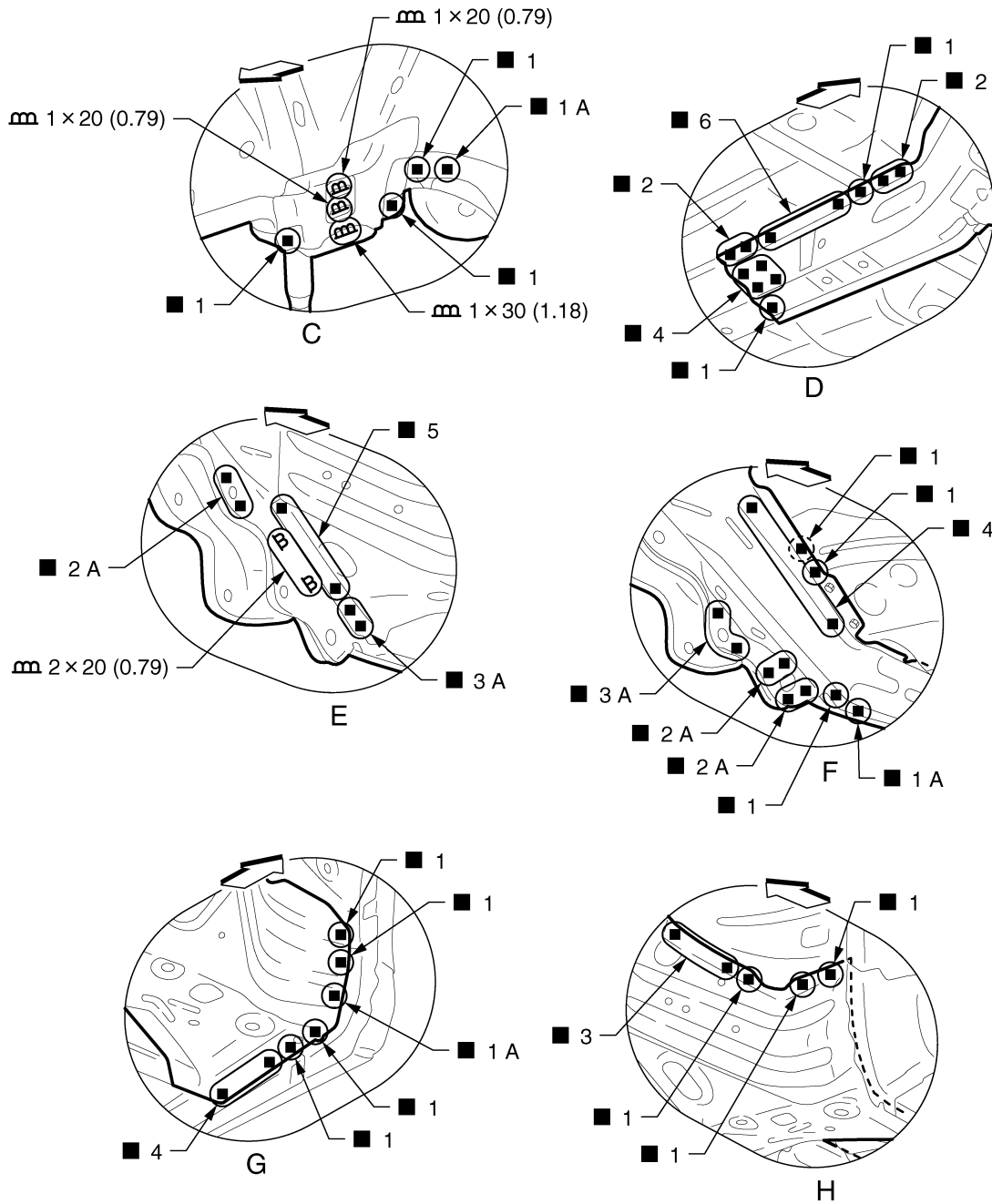

A
B
C
D
E
F
G
H
I
J
L
M
N
O
P

BRM

Unit: mm (in)

↔: Vehicle front

View F: Before installing front side member outrigger assembly

JSKIA0599GB

REPLACEMENT OPERATIONS

< REMOVAL AND INSTALLATION >

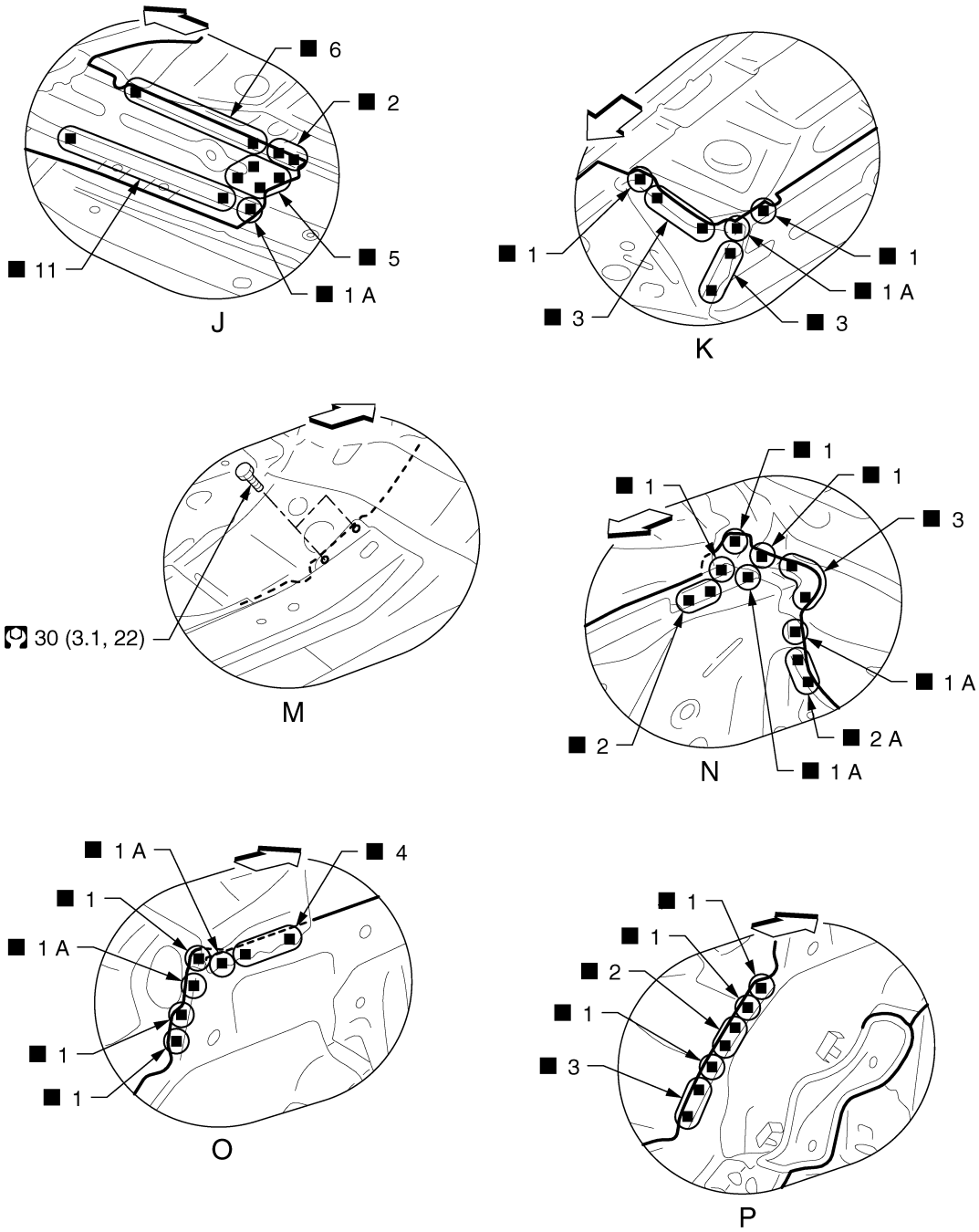

JSKIA0600GB

←: Vehicle front

Refer to [GI-4, "Components"](#) for symbols in the figure.

Front Side Member (Partial Replacement)

INFOID:000000005172895

Work after radiator core support is removed.

REPLACEMENT OPERATIONS

< REMOVAL AND INSTALLATION >

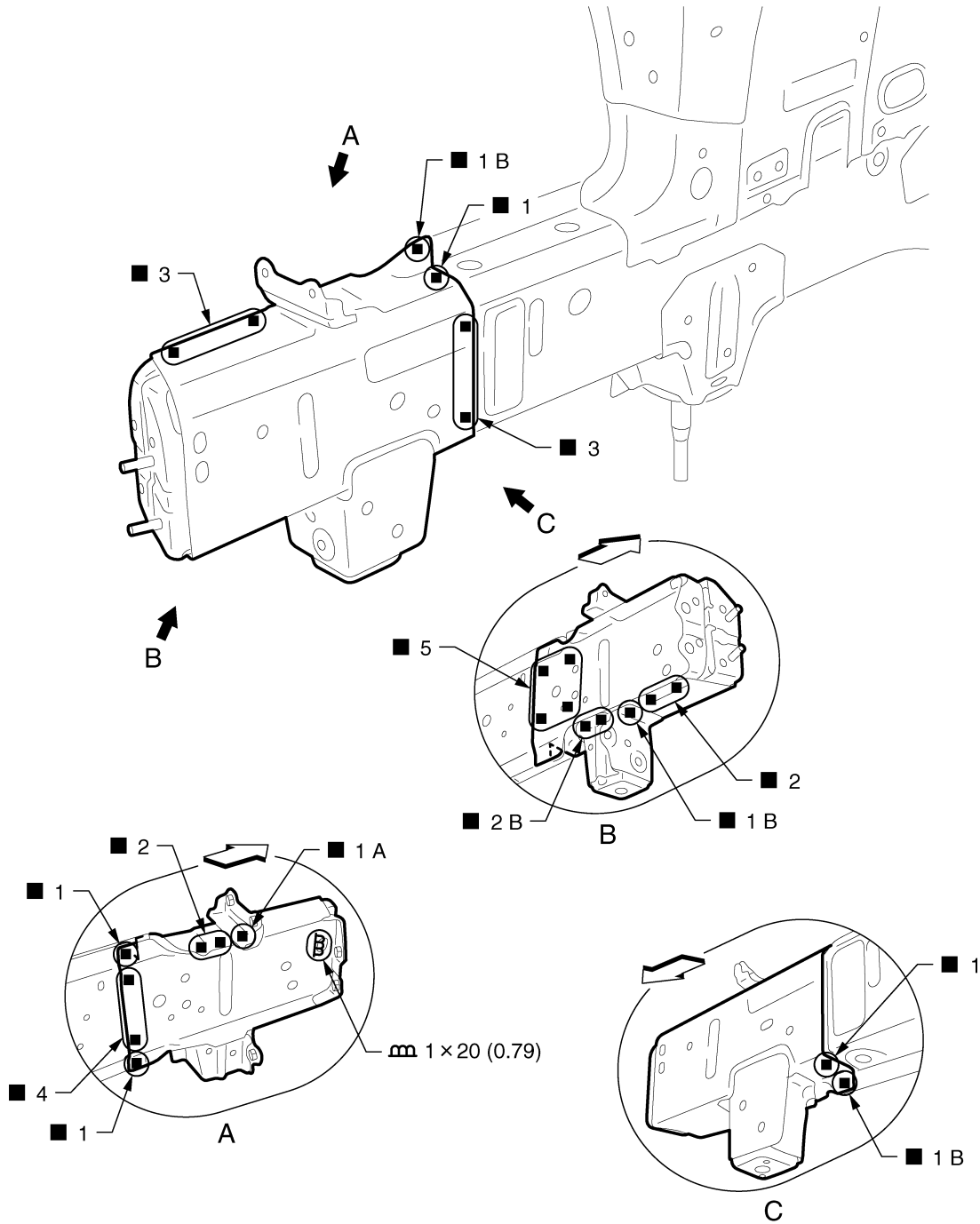

JSKIA1062GB

Unit: mm (in)

↔: Vehicle front

Replacement parts

- Front side member front extension (RH)
- Front side member front closing plate (RH)
- Front side rear closing reinforcement (RH)

Front Pillar

Work after hoodledge reinforcement and roof are removed.

INFOID:000000005172896

A
B
C
D
E
F
G
H
I
J
BRM
L
M
N
O
P

REPLACEMENT OPERATIONS

< REMOVAL AND INSTALLATION >

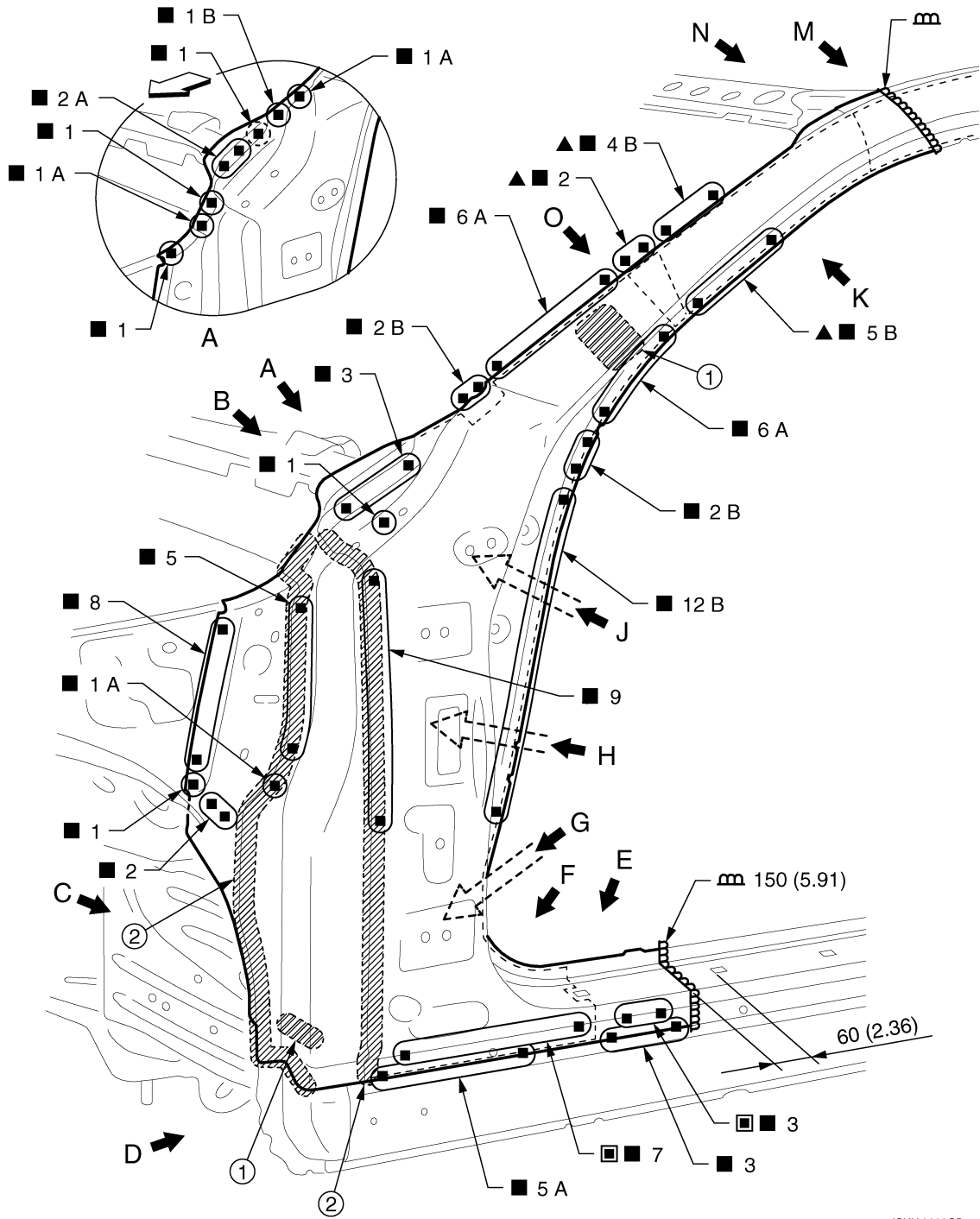

JSKIA0602GB

1. Urethane foam

2. Body sealing

Unit: mm (in)

↔: Vehicle front

▲: Drill $\phi 8$ mm (0.31 in) hole for the plug welding hole (ultra high strength steel plate).

■: Perform the plug welding instead of the laser welding.

Replacement parts

- Outer front side body (LH)
- Front pillar brace (LH)
- Outer side roof rail reinforcement (LH)
- Upper rear hoodledge (LH)
- Upper inner front pillar assembly (LH)

REPLACEMENT OPERATIONS

< REMOVAL AND INSTALLATION >

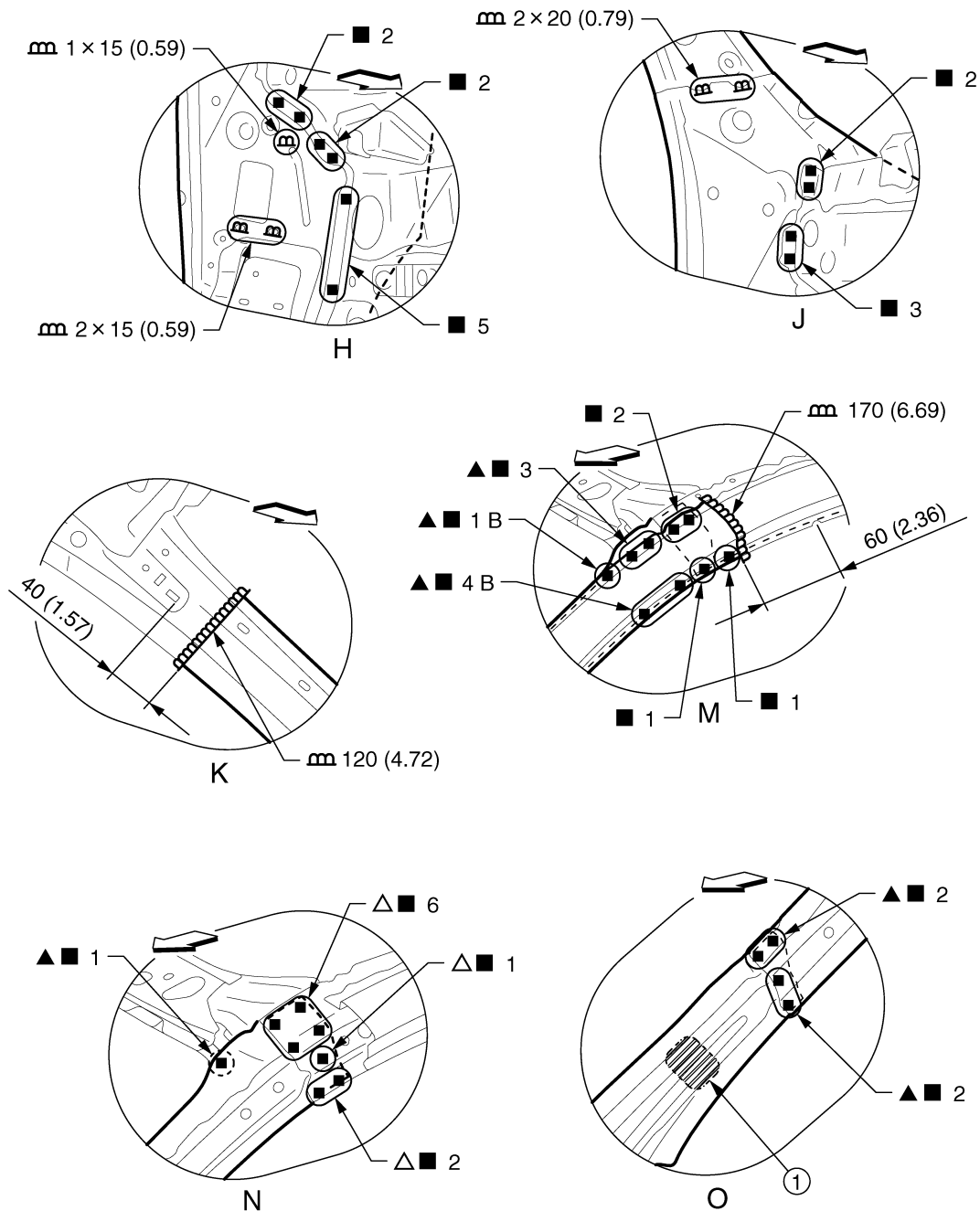

JSKIA0604GB

Unit: mm (in)

↔: Vehicle front

▲: Drill $\phi 8$ mm (0.31 in) hole for the plug welding hole (ultra high strength steel plate).

△: Drill $\phi 11$ mm (0.43 in) hole for the plug welding hole (ultra high strength steel plate).

View N and O: Before installing outer front side body
Front Pillar (Partial Replacement)

INFOID:000000005172897

Work after hoodledge reinforcement is removed.

REPLACEMENT OPERATIONS

< REMOVAL AND INSTALLATION >

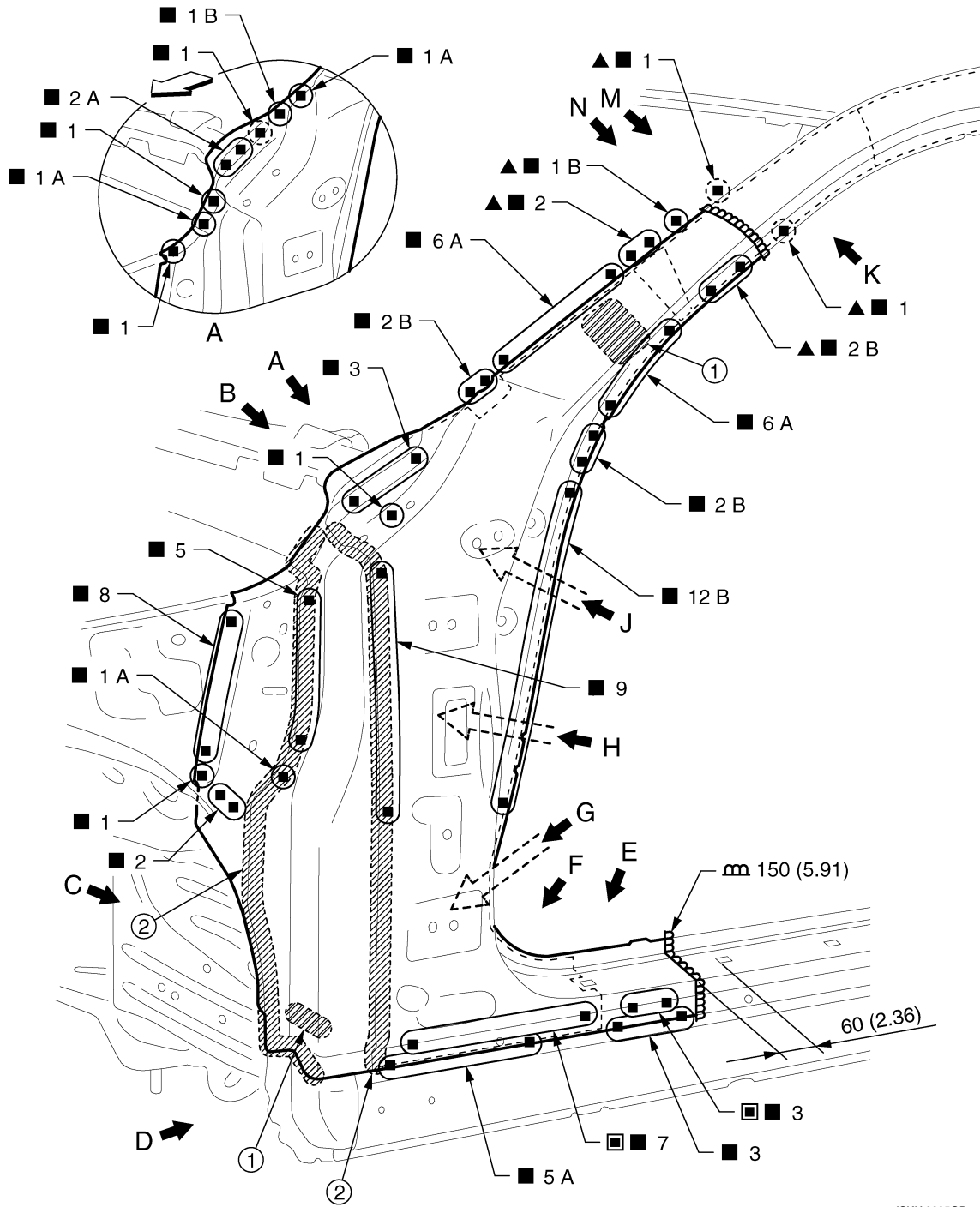

JSKIA0605GB

1. Urethane foam

2. Body sealing

Unit: mm (in)

←: Vehicle front

▲: Drill $\phi 8$ mm (0.31 in) hole for the plug welding hole (ultra high strength steel plate).

■: Perform the plug welding instead of the laser welding.

Replacement parts

- Outer front side body (LH)
- Front pillar brace (LH)
- Upper rear hoodledge (LH)
- Upper inner front pillar assembly (LH)

A
B
C
D
E
F
G
H
I
J
K
L
M
N
O
P

BRM

REPLACEMENT OPERATIONS

< REMOVAL AND INSTALLATION >

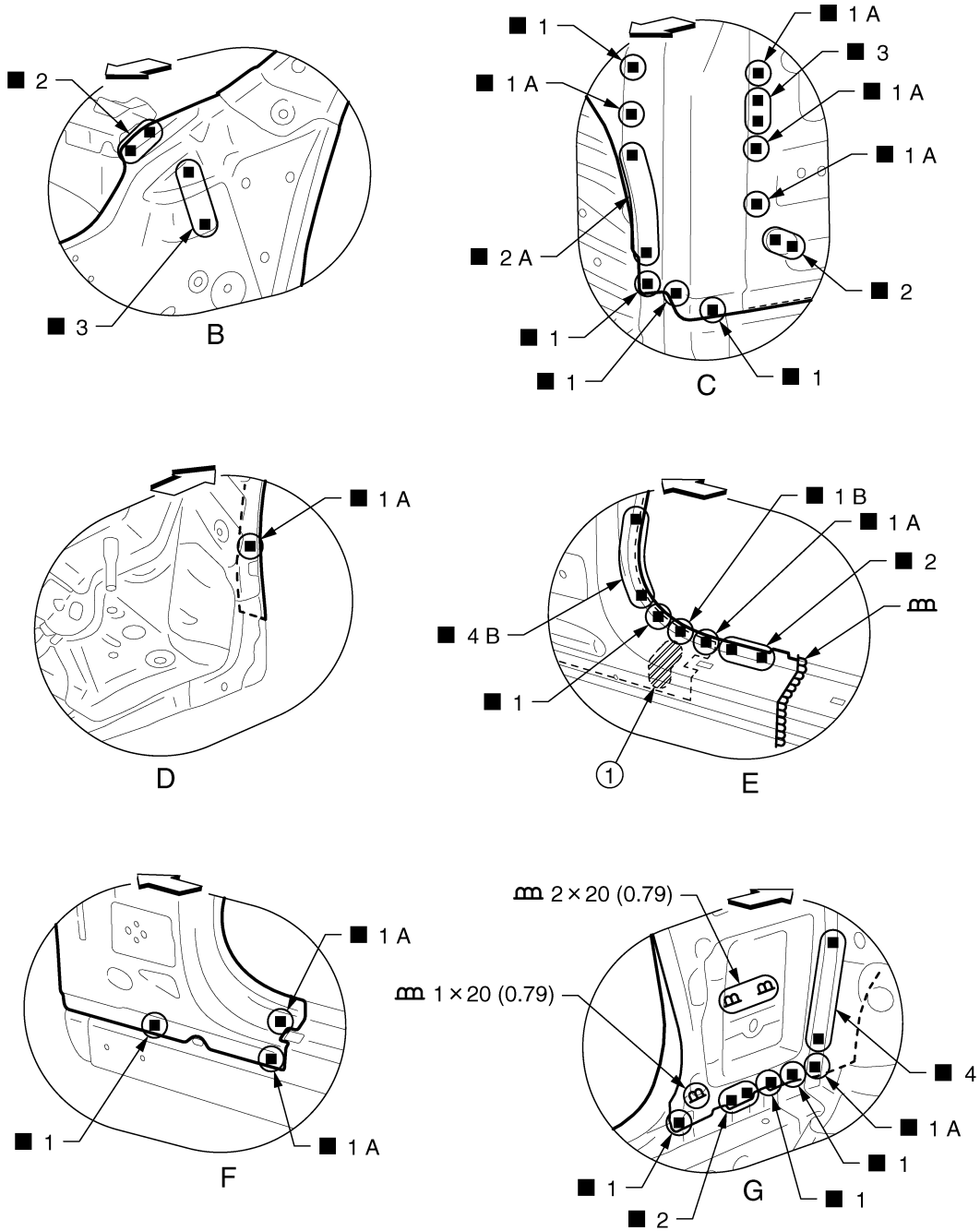

JSKIA0606GB

1. Urethane foam

Unit: mm (in)

↔: Vehicle front

View B: Before installing outer front side body and front pillar brace

View F: Before installing outer front side body

REPLACEMENT OPERATIONS

< REMOVAL AND INSTALLATION >

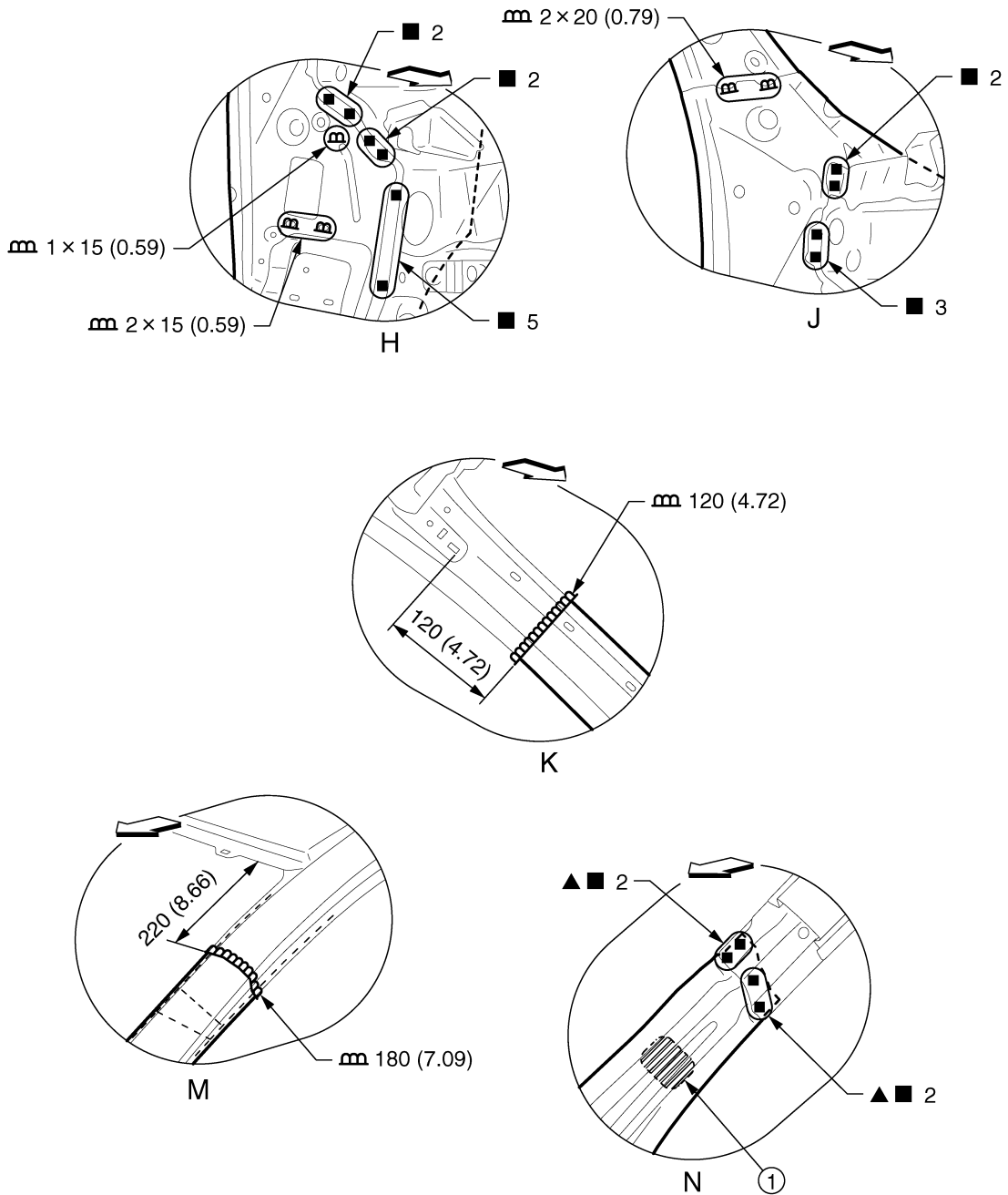

A
B
C
D
E
F
G
H
I
J
L
M
N
O
P

BRM

JSKIA0607GB

1. Urethane foam

Unit: mm (in)

↔: Vehicle front

▲: Drill $\phi 8$ mm (0.31 in) hole for the plug welding hole (ultra high strength steel plate).

View N: Before installing outer front side body

Center Pillar

Work after roof is removed.

INFOID:000000005172898

REPLACEMENT OPERATIONS

< REMOVAL AND INSTALLATION >

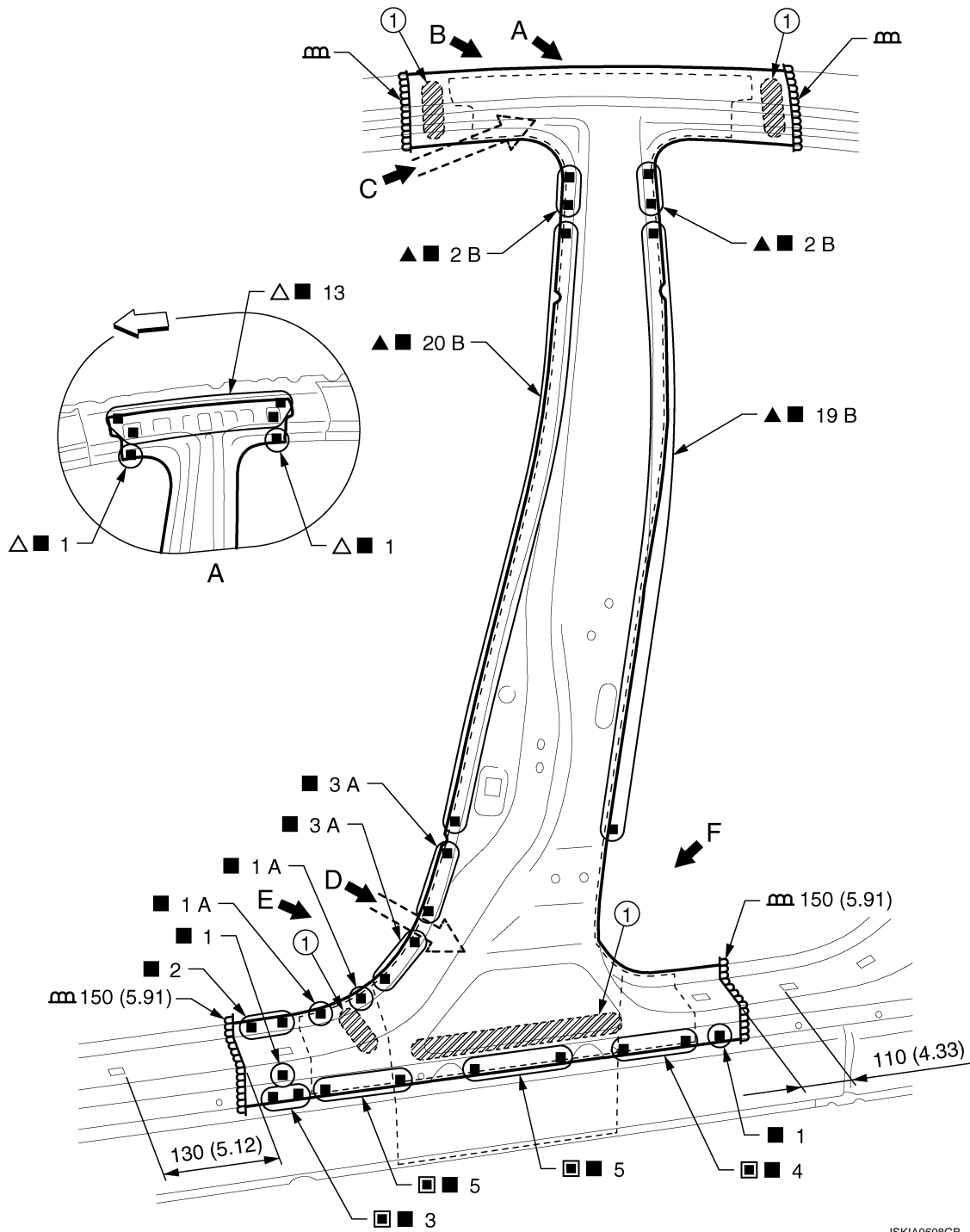

JSKIA0608GB

1. Urethane foam

Unit: mm (in)

↔: Vehicle front

▲: Drill $\phi 10$ mm (0.39 in) hole for the plug welding hole (ultra high strength steel plate).

△: Drill $\phi 11$ mm (0.43 in) hole for the plug welding hole (ultra high strength steel plate).

■: Perform the plug welding instead of the laser welding.

Replacement parts

● Outer front side body (LH)

● Center pillar reinforcement (LH)

● Inner center pillar (LH)

View A: Before installing outer front side body

REPLACEMENT OPERATIONS

< REMOVAL AND INSTALLATION >

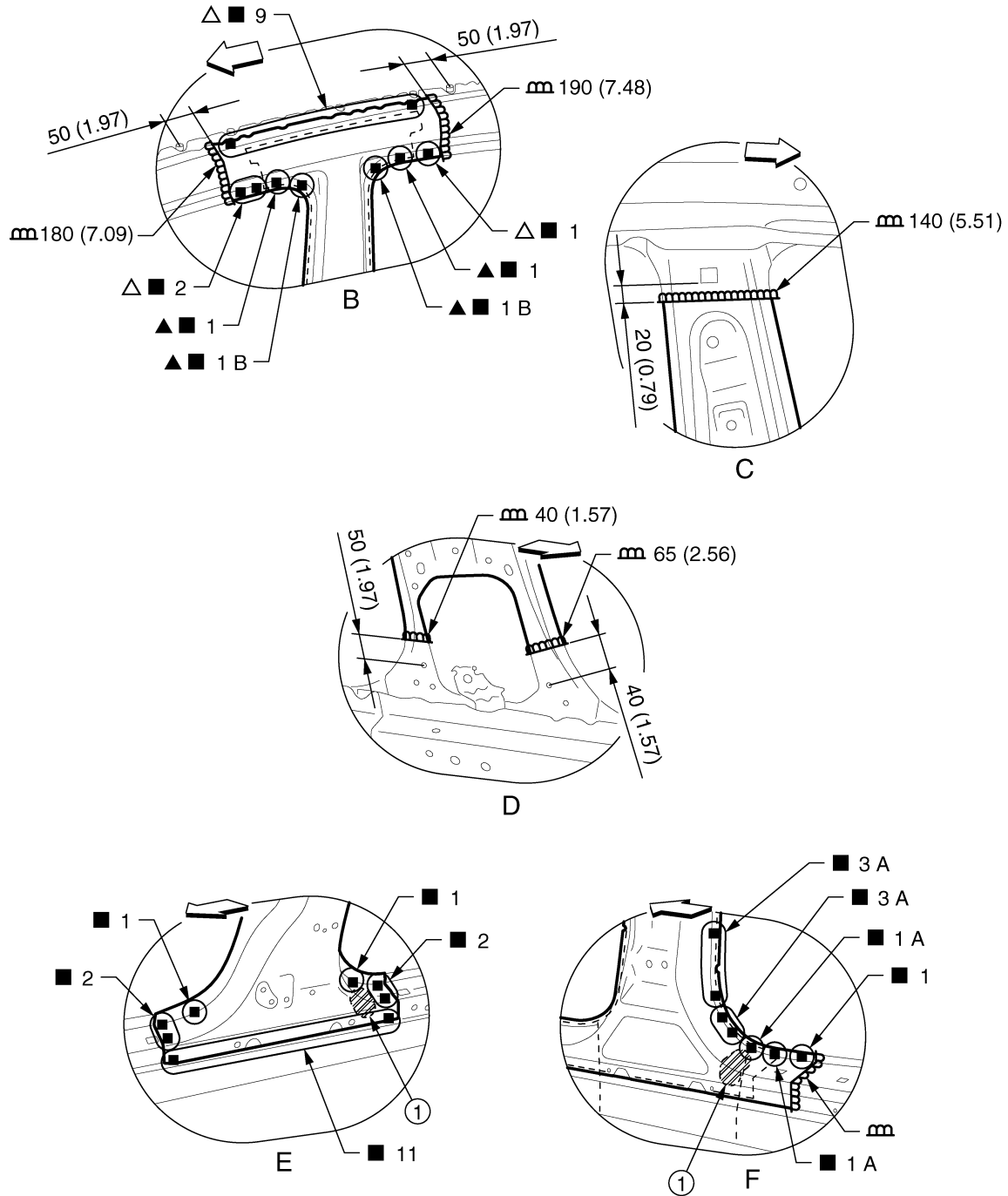

A
B
C
D
E
F
G
H
I
J
K
L
M
N
O
P

BRM

1. Urethane foam
Unit: mm (in)

←: Vehicle front

▲: Drill $\phi 10$ mm (0.39 in) hole for the plug welding hole (ultra high strength steel plate).

△: Drill $\phi 11$ mm (0.43 in) hole for the plug welding hole (ultra high strength steel plate).

View E: Before installing outer front side body

Outer Sill

Work after hoodledge reinforcement is removed.

JSKIA0609GB

INFOID:000000005172899

REPLACEMENT OPERATIONS

< REMOVAL AND INSTALLATION >

Remove the front pillar brace and the center pillar reinforcement (reusable).

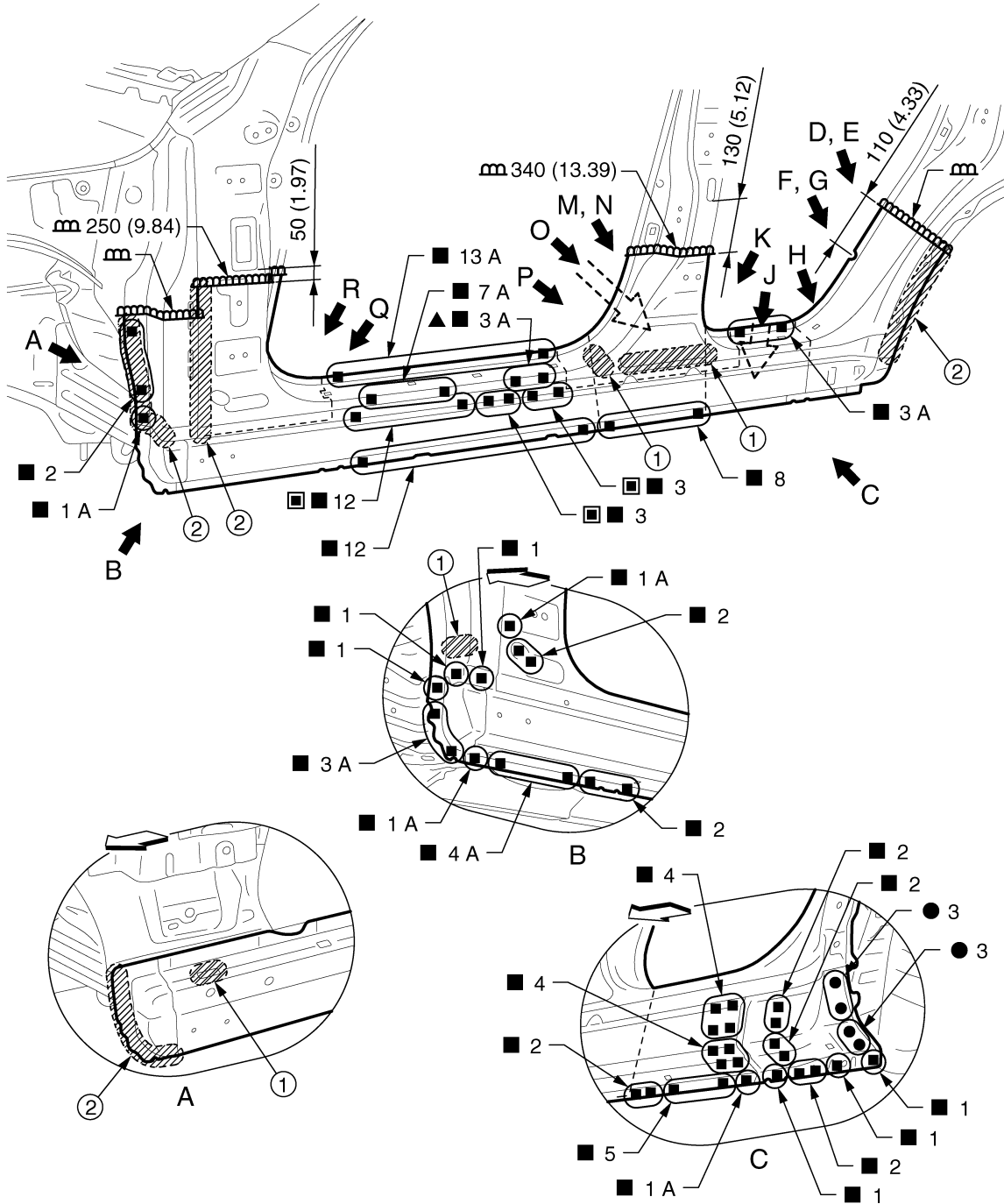

JSKIA0610GB

1. Urethane foam

2. Body sealing

Unit: mm (in)

↔: Vehicle front

▲: Drill $\phi 8$ mm (0.31 in) hole for the plug welding hole (ultra high strength steel plate).

■: Perform the plug welding instead of the laser welding.

Replacement parts

REPLACEMENT OPERATIONS

< REMOVAL AND INSTALLATION >

- Outer sill (LH)
- Outer sill reinforcement (LH)
- Upper outer rear wheelhouse extension (LH)
- Lower outer rear wheelhouse extension (LH)

View A: Before installing outer sill and front pillar brace

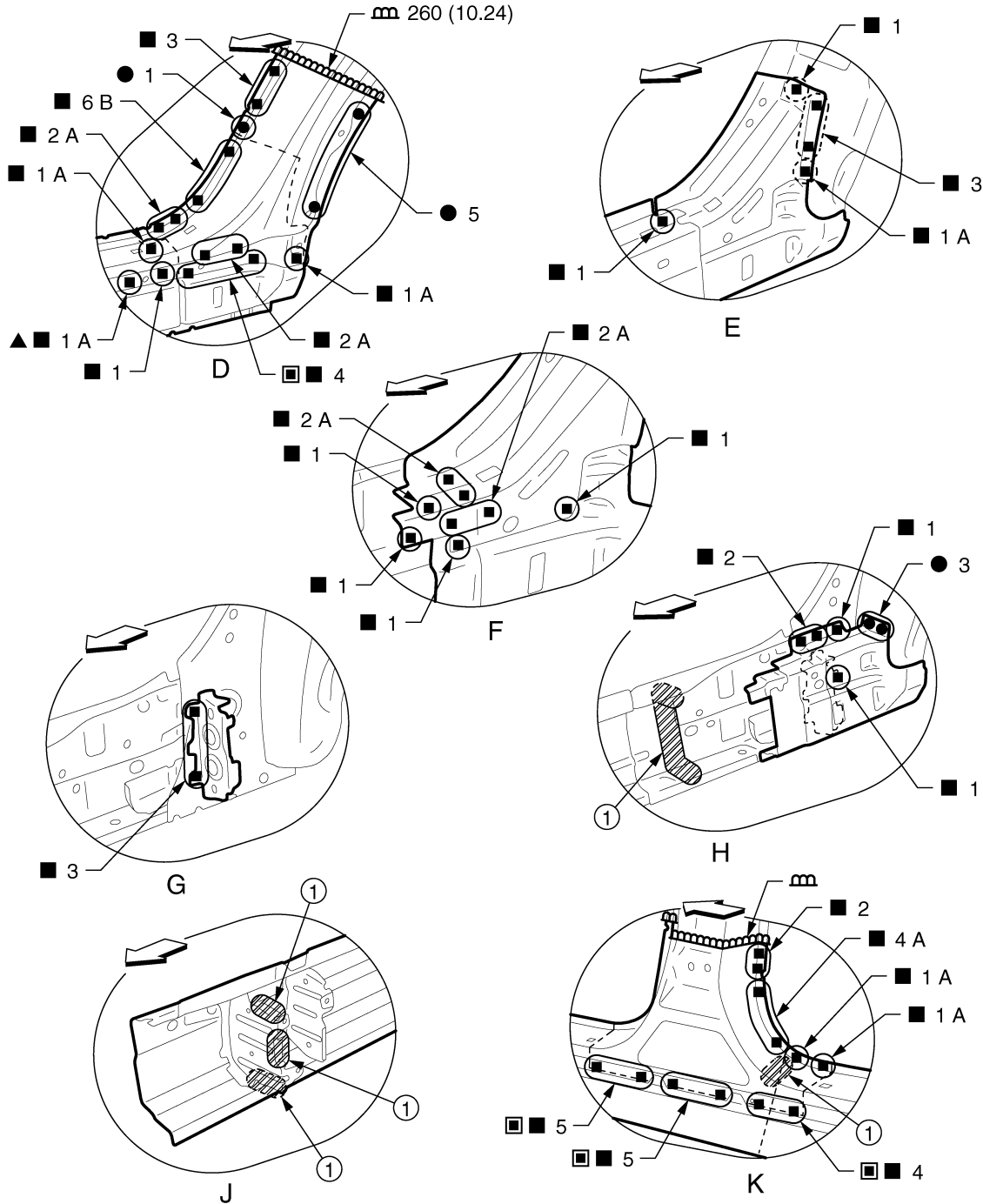

JSKIA0611GB

1. Urethane foam

Unit: mm (in)

←: Vehicle front

▲: Drill $\phi 8$ mm (0.31 in) hole for the plug welding hole (ultra high strength steel plate).

■: Perform the plug welding instead of the laser welding.

REPLACEMENT OPERATIONS

< REMOVAL AND INSTALLATION >

View E: Before installing outer sill

View F: Before installing outer sill and outer sill reinforcement

View G: Before installing outer sill, outer sill reinforcement, upper outer rear wheelhouse extension, and lower outer rear wheelhouse extension

View H: Before installing outer sill, outer sill reinforcement, and upper outer rear wheelhouse extension

View J: Outer sill reinforcement (replacement parts)

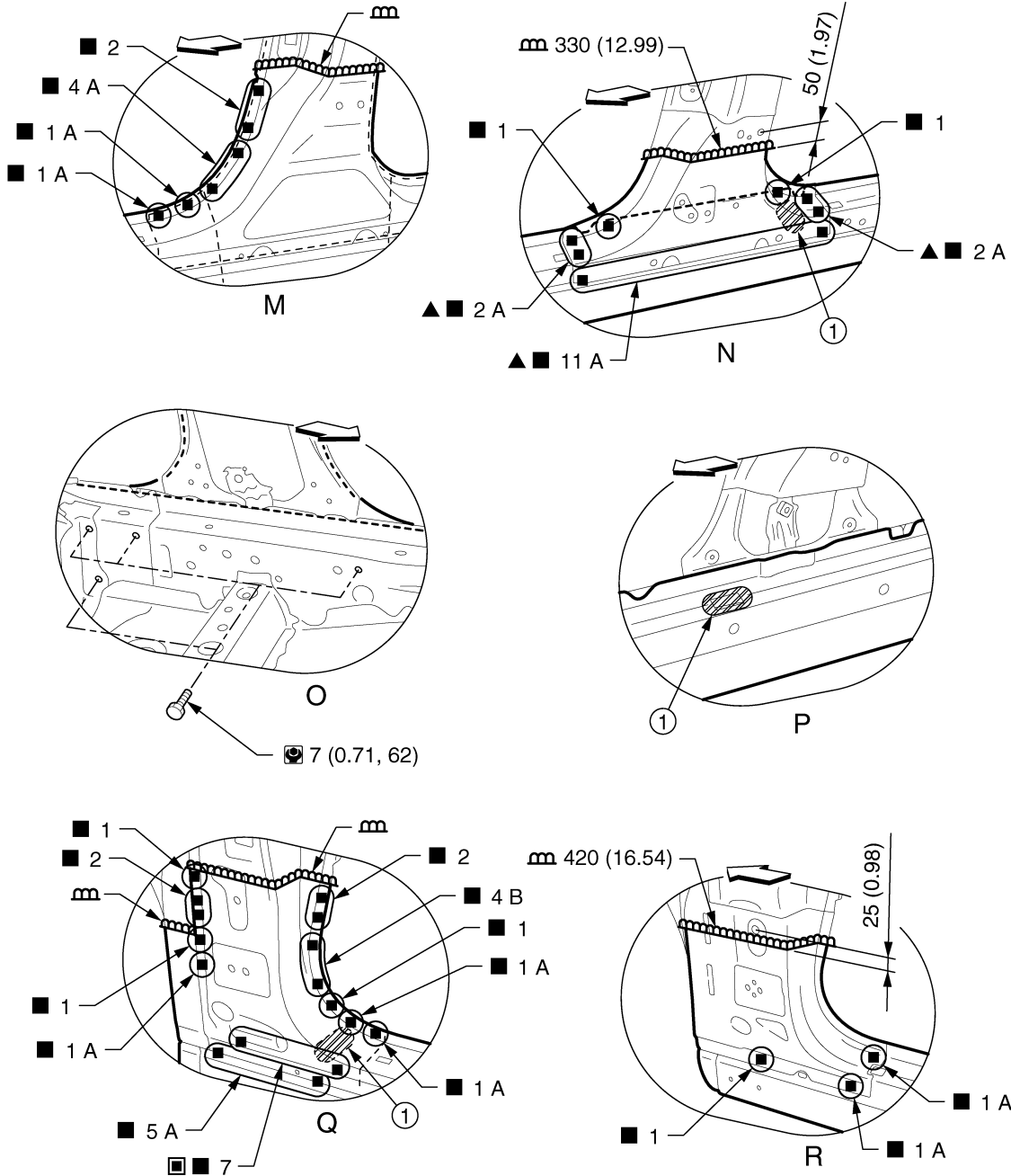

JSKIA0612GB

1. Urethane foam

Unit: mm (in)

←: Vehicle front

▲: Drill $\phi 8$ mm (0.31 in) hole for the plug welding hole (ultra high strength steel plate).

REPLACEMENT OPERATIONS

< REMOVAL AND INSTALLATION >

■: Perform the plug welding instead of the laser welding.

Refer to [GI-4, "Components"](#) for symbols in the figure.

View N and R: Before installing outer sill

View P: Before installing outer sill and center pillar reinforcement

Rear Fender

INFOID:000000005172900

Remove the tail pillar assembly and rear fender extension from the rear fender assembly service part for easier installation.

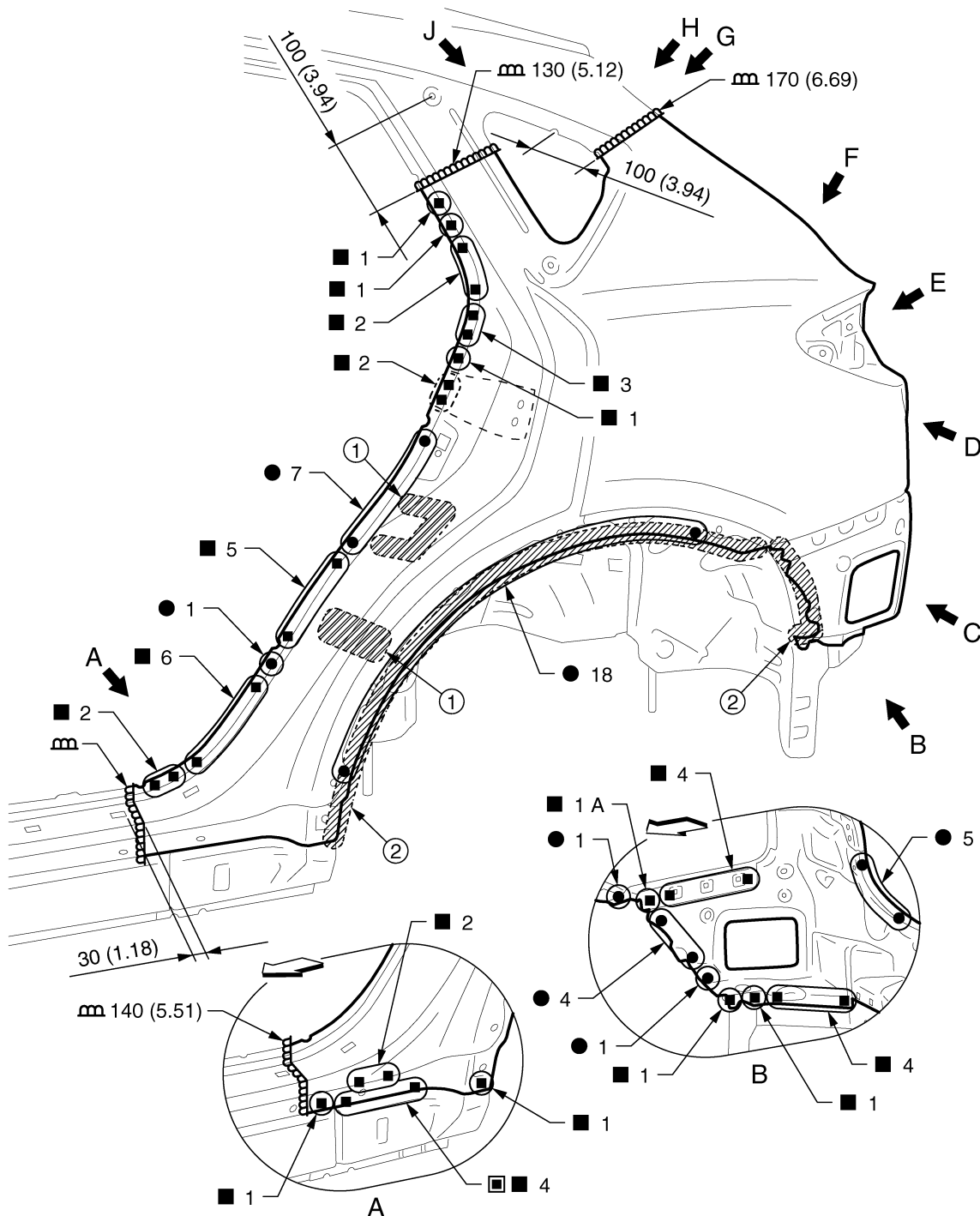

1. Urethane foam
Unit: mm (in)

2. Body sealing

REPLACEMENT OPERATIONS

< REMOVAL AND INSTALLATION >

↔: Vehicle front

■: Perform the plug welding instead of the laser welding.

Replacement parts

- Rear fender assembly (LH)

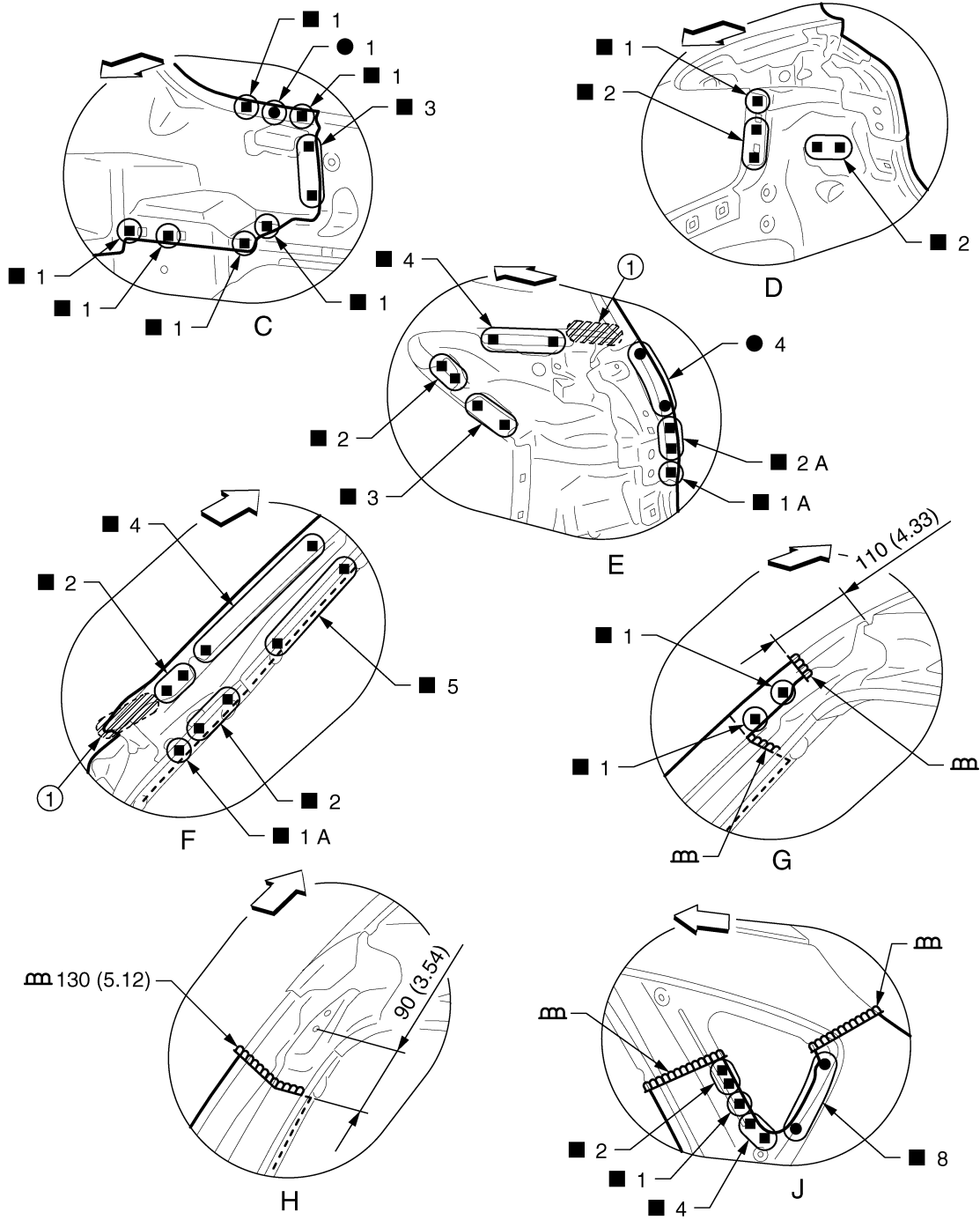

JSKIA0614GB

1. Urethane foam

Unit: mm (in)

↔: Vehicle front

View H: Before installing rear fender

REPLACEMENT OPERATIONS

< REMOVAL AND INSTALLATION >

Rear Panel

INFOID:000000005172901

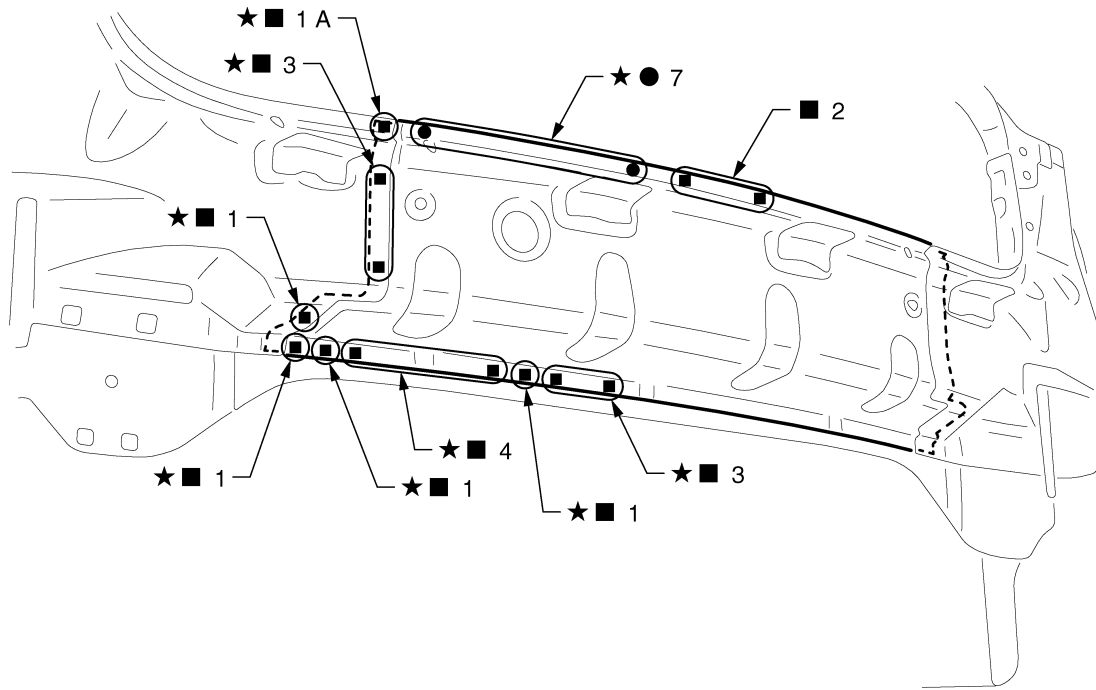

A
B
C
D
E
F
G
H
I
J

BRM

L
M
N
O
P

JSKIA0615ZZ

★: An equivalent welding portion with the same dimensions is on the opposite side.

Replacement parts

- Rear panel assembly

Rear End Crossmember

INFOID:000000005172902

Work after rear panel is removed.

REPLACEMENT OPERATIONS

< REMOVAL AND INSTALLATION >

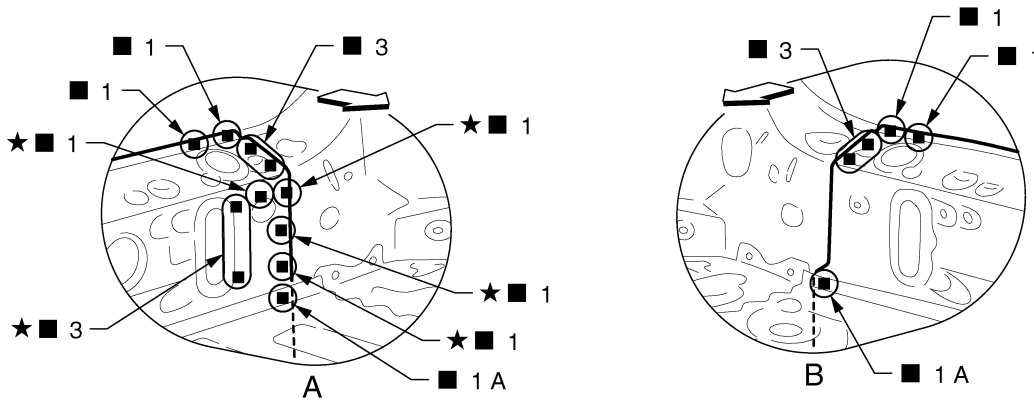
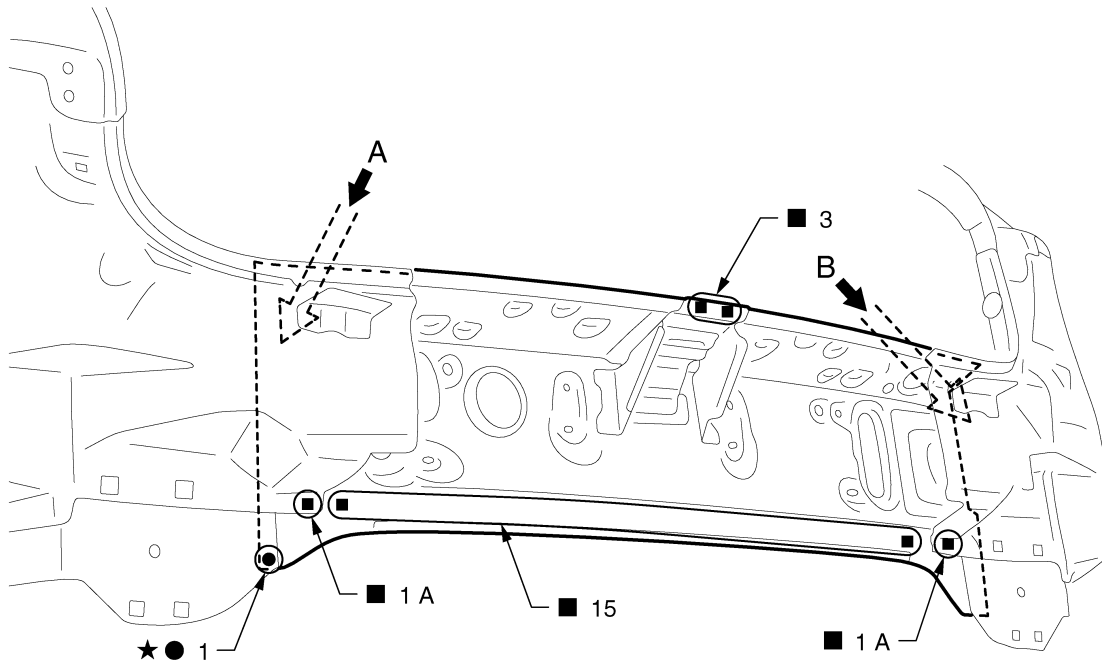

JSKIA0616ZZ

↶: Vehicle front

★: An equivalent welding portion with the same dimensions is on the opposite side.

Replacement parts

- Rear end crossmember assembly

Rear Floor Rear

INFOID:000000005172903

Work after rear panel and rear end crossmember assembly are removed.

REPLACEMENT OPERATIONS

< REMOVAL AND INSTALLATION >

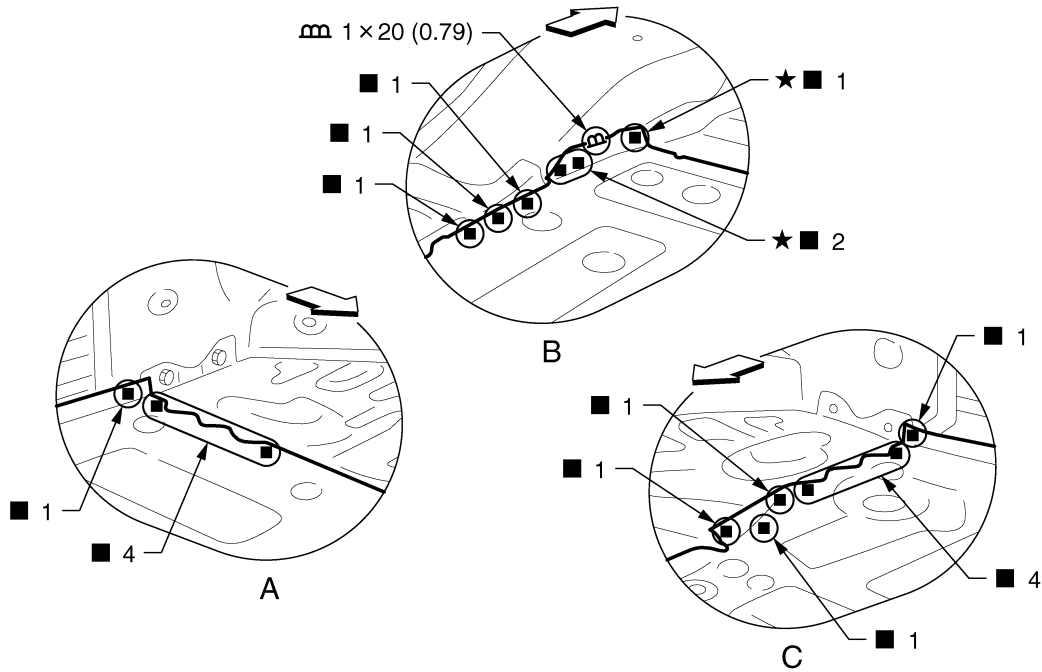
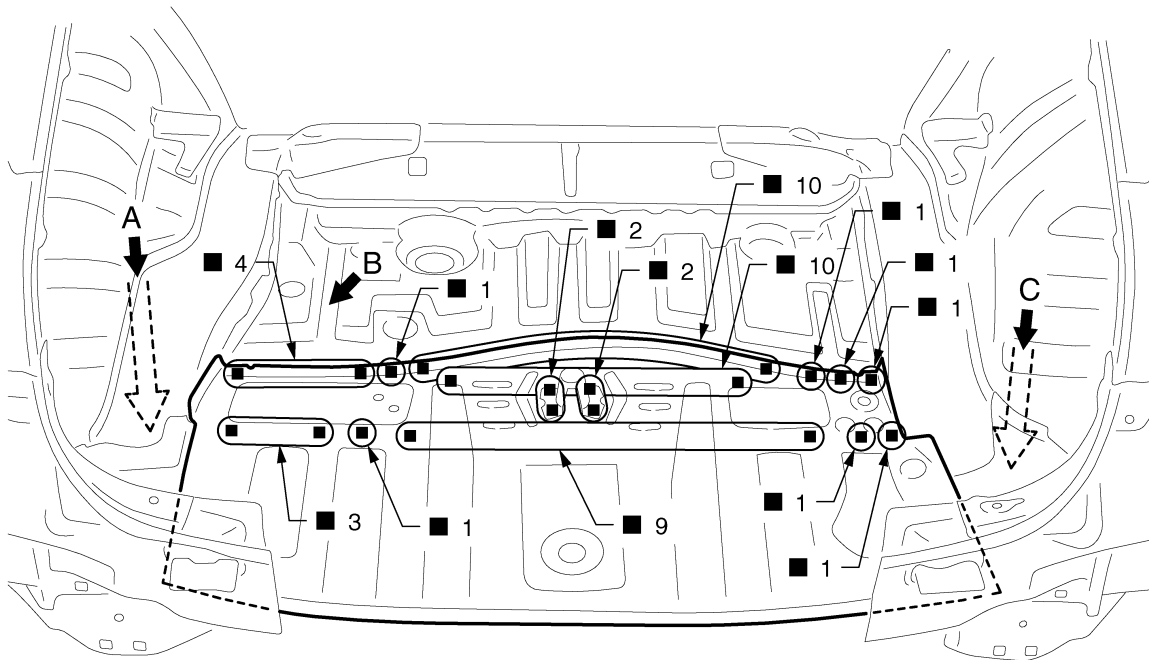

JSKIA0617GB

unit: mm (in)

↔: Vehicle front

★: An equivalent welding portion with the same dimensions is on the opposite side.

Replacement parts

● Rear floor rear

● Spare tire clamp bracket

Rear Side Member Extension

INFOID:000000005172904

Work after rear panel, rear end crossmember, rear fender extension, and lower inner rear pillar are removed.

A
B
C
D
E
F
G
H
I
J
K
L
M
N
O
P

BRM

REPLACEMENT OPERATIONS

< REMOVAL AND INSTALLATION >

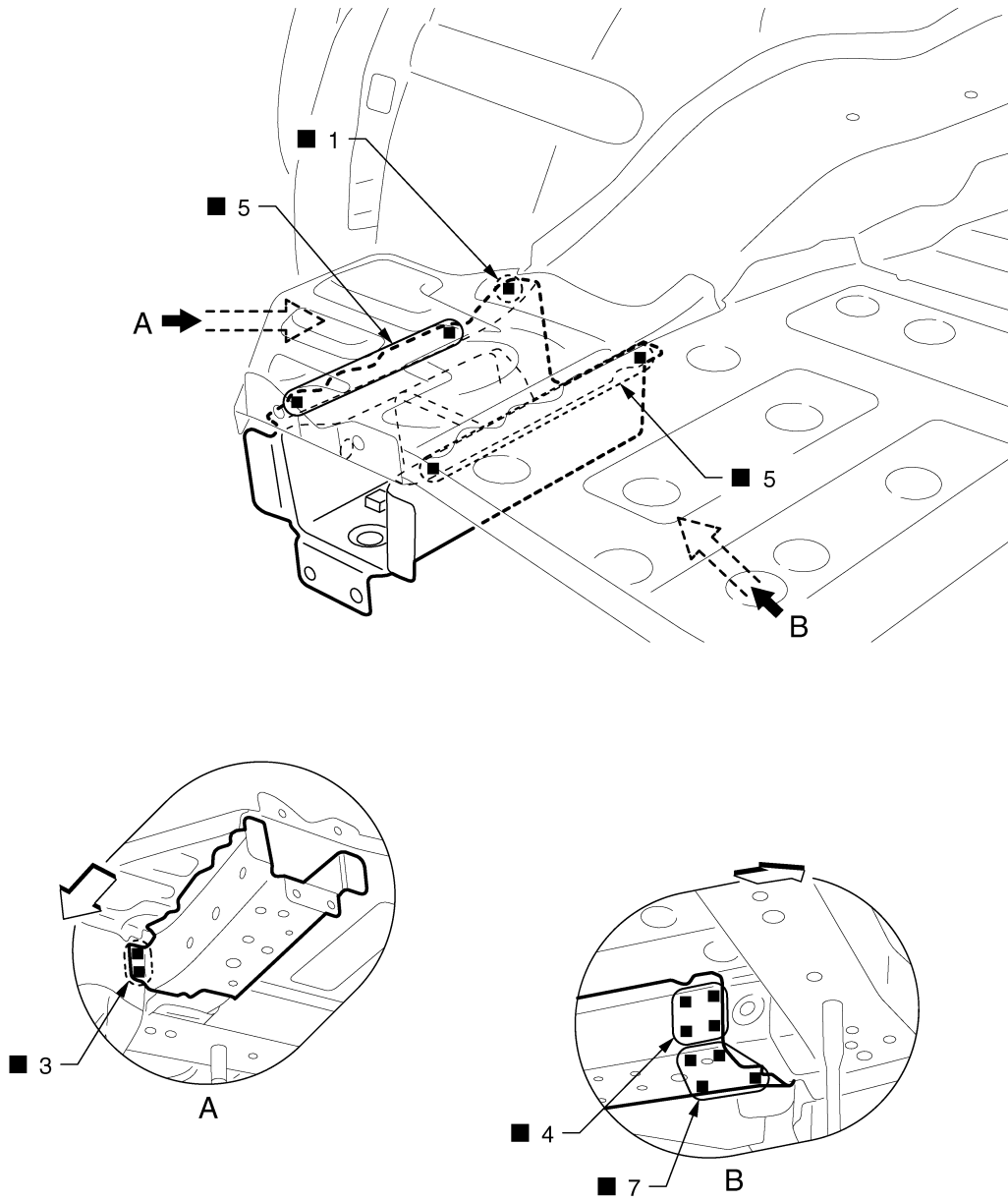

JSKIA0618ZZ

↔: Vehicle front

Replacement parts

- Rear side member extension (LH)

BODY ALIGNMENT

< SERVICE DATA AND SPECIFICATIONS (SDS)

SERVICE DATA AND SPECIFICATIONS (SDS)

BODY ALIGNMENT

Body Center Marks

INFOID:000000005172876

A mark is placed on each part of the body to indicate the vehicle center. When repairing the vehicle frame (members, pillars, etc.) damaged by an accident which it enables more accurate and effective repair by using these marks together with body alignment specifications.

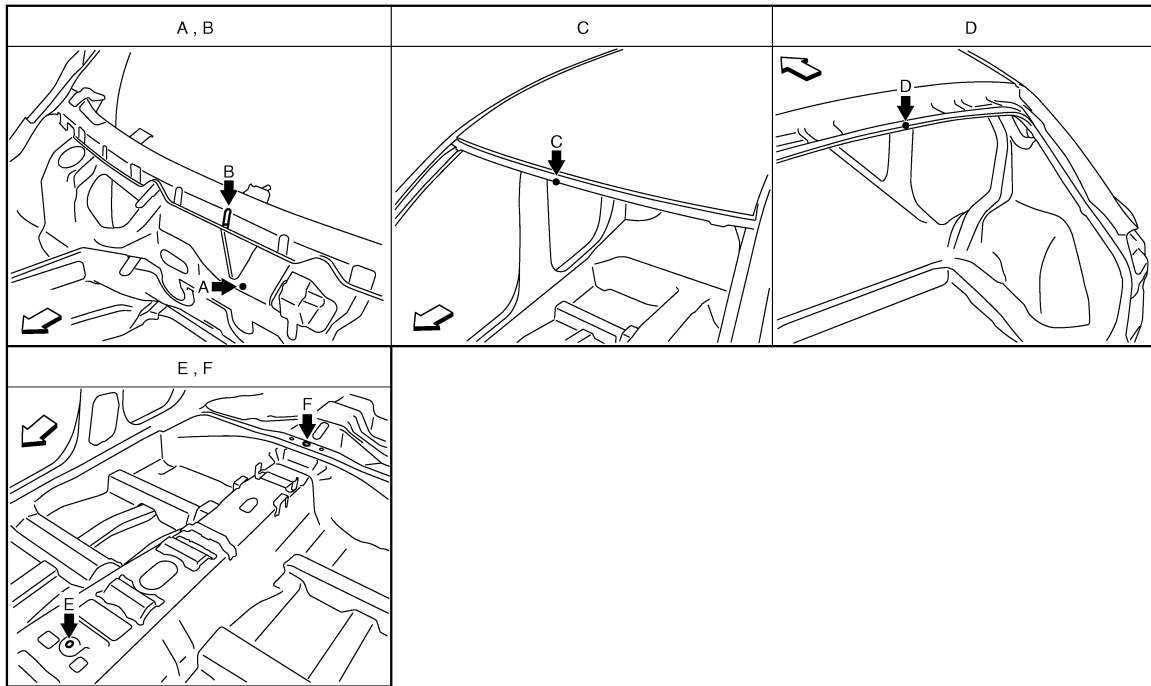
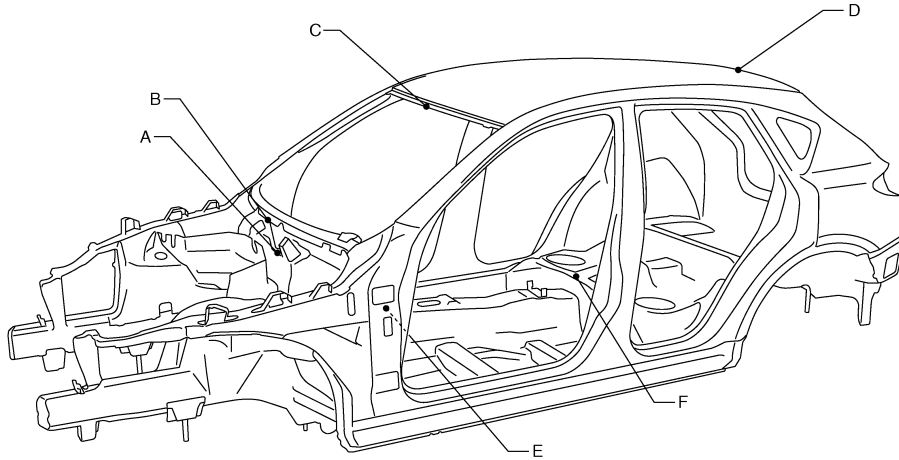

JSKIA0578ZZ

↶ Vehicle front

Unit: mm (in)

Points	Portion	Marks
A	Upper dash	Embossment
B	Upper dash crossmember	Bead
C	Front roof	Embossment
D	Rear roof	Indent

A
B
C
D
E
F
G
H
I
J
K
L
M
N
O
P

BRM

BODY ALIGNMENT

< SERVICE DATA AND SPECIFICATIONS (SDS)

Points	Portion	Marks
E	Trans control reinforcement	Hole 12×14 (0.47×0.55)
F	Rear seat crossmember reinforcement	Hole φ5 (0.20)

Description

INFOID:000000005172877

- All dimensions indicated in the figures are actual.
- When using a tracking gauge, adjust both pointers to equal length. Then check the pointers and gauge itself to make sure there is no free play.
- When a measuring tape is used, check that there is no elongation, twisting, or bending.
- Measurements should be taken at the center of the mounting holes.
- An asterisk (*) following the value at the measuring point indicates that the measuring point on the other side is symmetrically the same value.
- The coordinates of the measurement points are the distances measured from the standard line of "X", "Y" and "Z".
- "Z": Imaginary base line [200 mm (7.87 in) below datum line ("0Z" at design plan)]

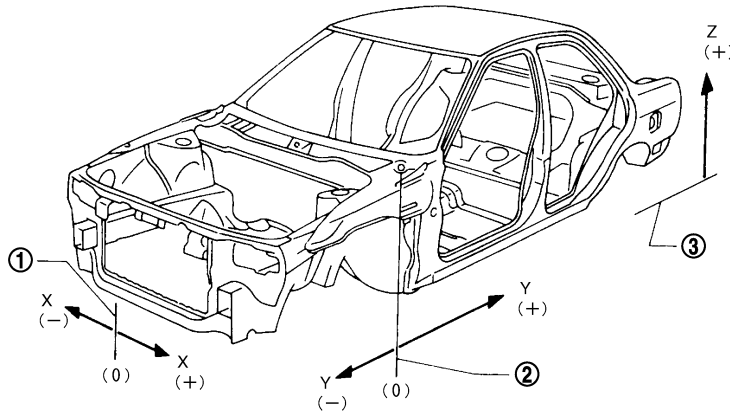

JSKIA0073GB

1. Vehicle center

2. Front axle center

3. Imaginary base line

Engine Compartment

INFOID:000000005172878

Measurement

Dimensions marked with "*" indicate symmetrically identical dimensions on both the right and left hand of the vehicle.

BODY ALIGNMENT

< SERVICE DATA AND SPECIFICATIONS (SDS)

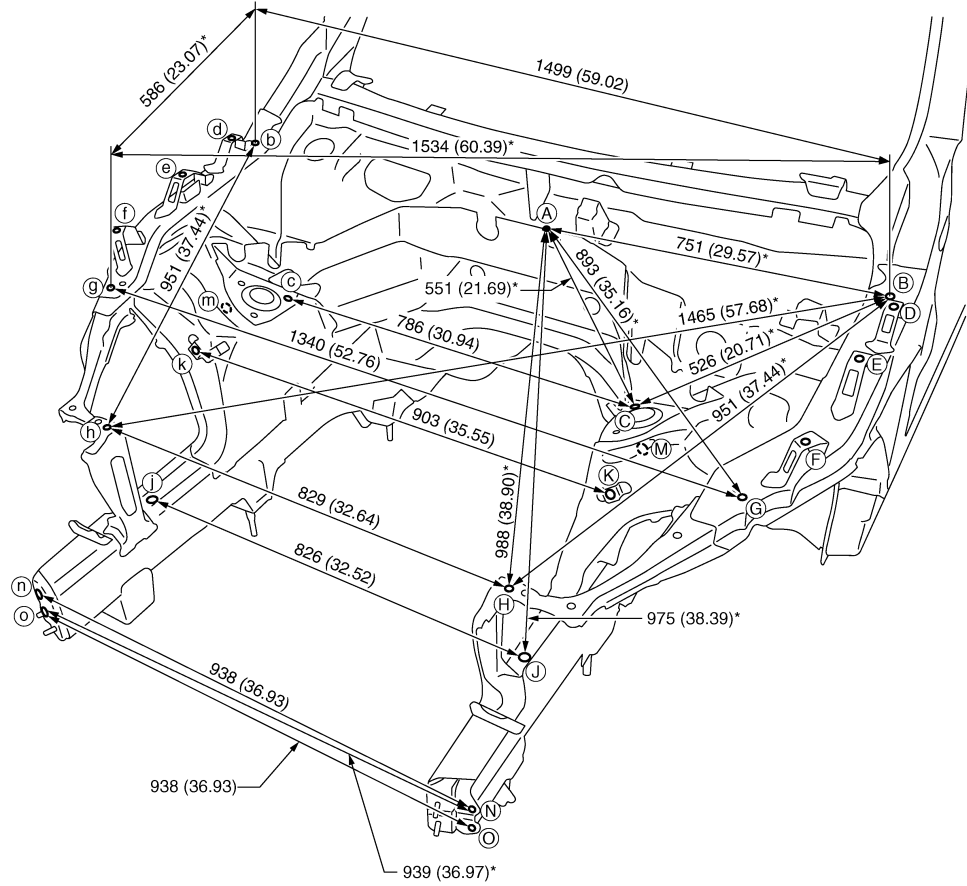

JSKIA0561GB

Unit: mm (in)

«The others»

Unit: mm (in)

Point	Dimension	Memo	Point	Dimension	Memo	Point	Dimension	Memo	Point	Dimension	Memo
A - D	770 (30.31)*		B - d	1514 (59.61)*		C - k	875 (34.45)*		F - f	1471 (57.91)	
A - E	797 (31.38)*		B - E	246 (9.69)*		D - d	1525 (60.04)		M - m	903 (35.55)	
A - F	894 (35.20)*		B - e	1520 (59.84)*		D - F	435 (17.13)*				
B - c	1206 (47.48)*		B - F	493 (19.41)*		D - f	1559 (61.38)*				
B - D	70 (2.76)*		B - f	1565 (61.61)*		E - e	1502 (59.13)				

Measurement Points

BODY ALIGNMENT

< SERVICE DATA AND SPECIFICATIONS (SDS)

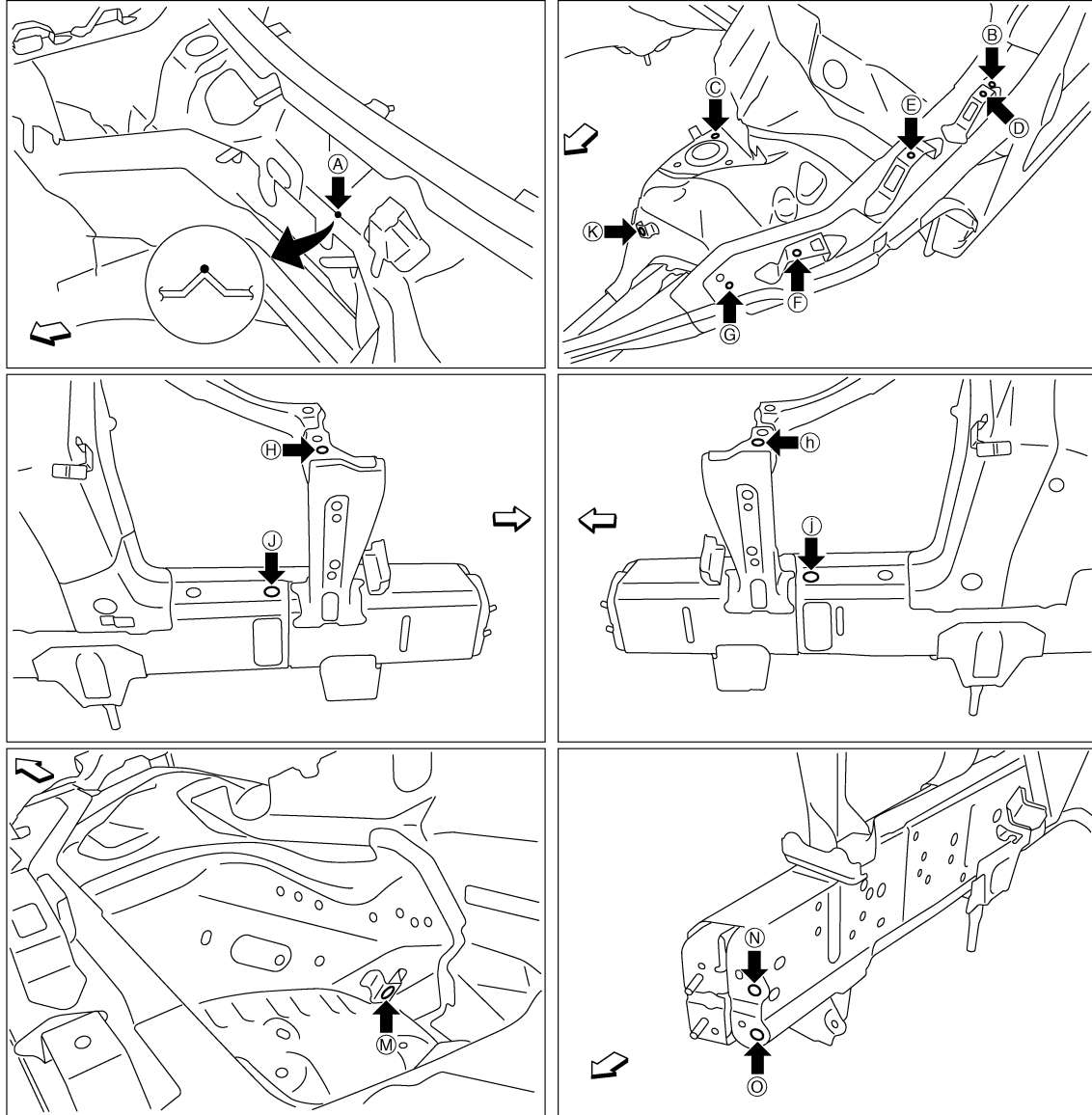

JSKIA0562ZZ

↔: Vehicle front

Unit: mm (in)

Point	Material	Point	Material
A	Upper dash positioning mark of center positioning mark	H, h	Radiator core stay installing hole center $\phi 12$ (0.47)
B, b, G, g	Hoodedge reinforcement hole center B, b: $\phi 9$ (0.35) G, g: $\phi 5$ (0.20)	J, j	Front side member hole center $\phi 20$ (0.79)
C, c	Front strut installing hole center $\phi 11$ (0.43)	K, k, M, m	Nut holder hole center $\phi 16$ (0.63)
D, d, E, e, F, f	Front fender installing hole center $\phi 7$ (0.28)	N, n, O, o	Front bumper stay installing hole center $\phi 11$ (0.43)

Underbody (2WD)

INFOID:000000005172879

Measurement

BODY ALIGNMENT

< SERVICE DATA AND SPECIFICATIONS (SDS)

Dimensions marked with "*" indicate symmetrically identical dimensions on both the right and left hand of the vehicle.

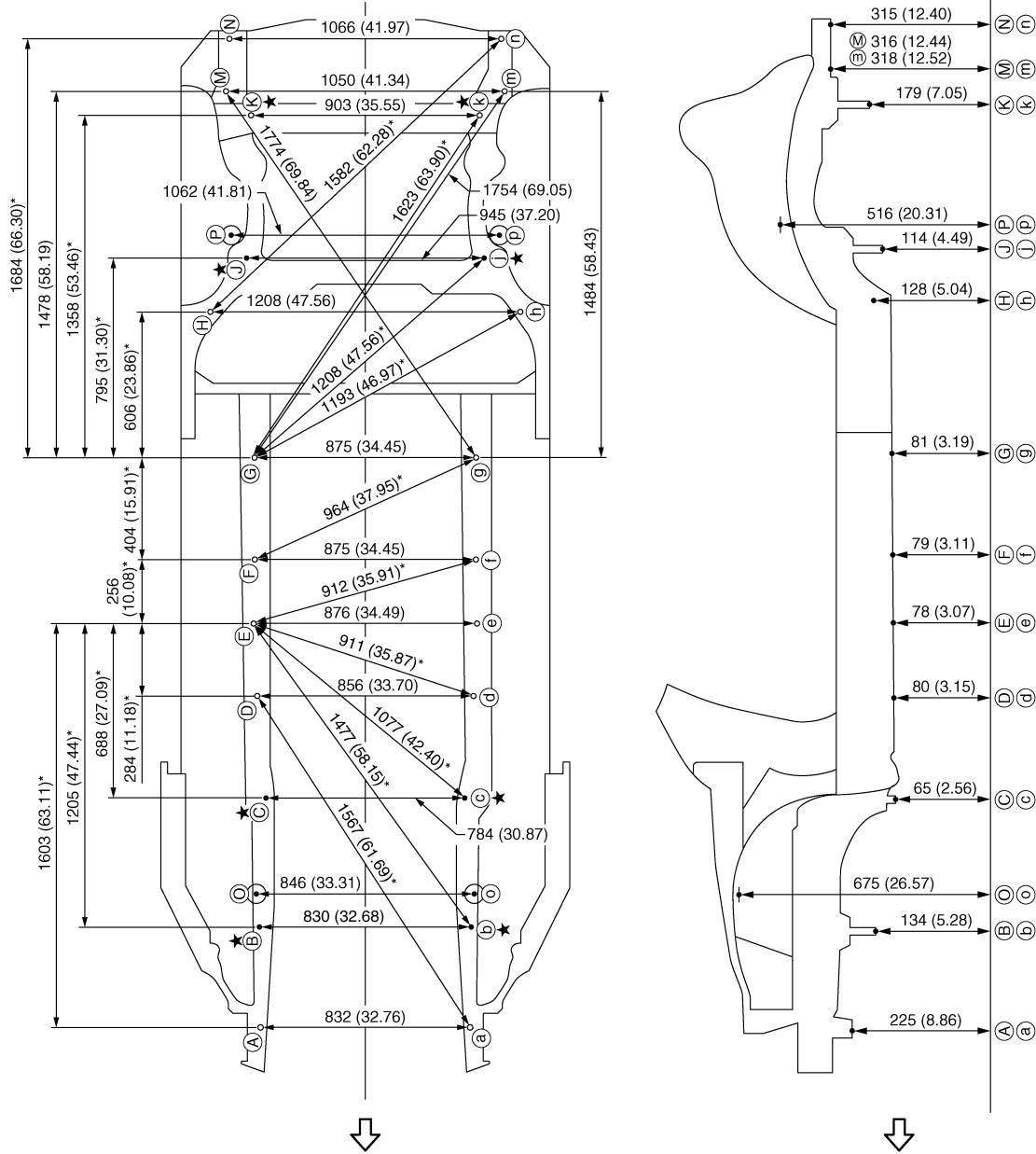

A
B
C
D
E
F
G
H
I
J
K
L
M
N
O
P

BRM

Unit: mm (in)

⇐ Vehicle front

★: Bolt head

Measurement Points

JSKIA0563GB

BODY ALIGNMENT

< SERVICE DATA AND SPECIFICATIONS (SDS)

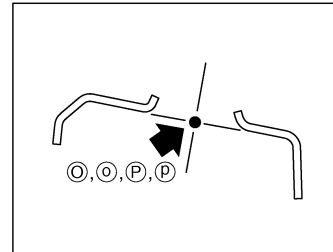
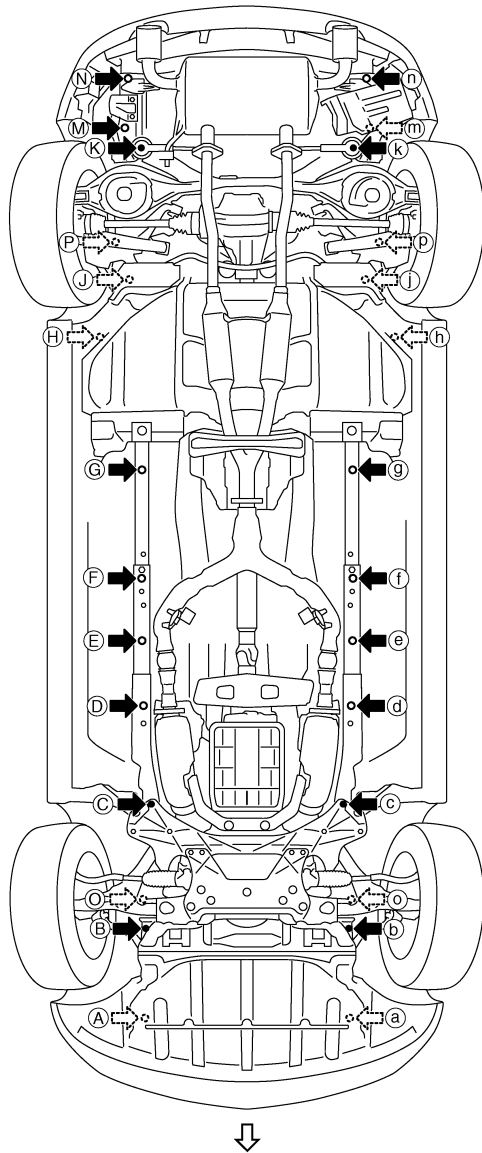

JSKIA0564ZZ

↶ Vehicle front

Unit: mm (in)

Points	Coordinates			Remarks	Points	Coordinates			Remarks
	X	Y	Z			X	Y	Z	
A, a	±416.0 (±16.378)	-496.0 (-19.528)	224.5 (8.839)	Hole φ13 (0.51)	J, j	±472.6 (±18.606)	2553.8 (100.543)	114.0 (4.488)	Bolt head
B, b	±415.0 (±16.339)	-104.0 (-4.094)	133.5 (5.256)	Bolt head	K, k	±451.5 (±17.776)	3113.9 (122.594)	179.1 (7.051)	Bolt head
C, c	±392.0 (±15.433)	414.0 (16.299)	64.5 (2.539)	Bolt head	M	550.0 (21.654)	3214.6 (126.559)	316.4 (12.457)	Hole φ8 (0.31)
D, d	±428.0 (±16.850)	816.6 (32.150)	80.0 (3.150)	Hole 16×18 (0.63×0.71)	m	-500.0 (-19.685)	3223.3 (126.901)	318.0 (12.520)	Hole φ8 (0.31)
E, e	±438.0 (±17.244)	1100.0 (43.307)	78.0 (3.071)	Hole φ16 (0.63)	N, n	±533.0 (±20.984)	3425.0 (134.842)	315.4 (12.417)	Hole φ16 (0.63)
F, f	±437.5 (±17.224)	1355.9 (53.382)	78.8 (3.102)	Hole φ14 (0.55)	O, o	±423.0 (±16.654)	38.0 (1.496)	674.5 (26.555)	Hole φ50 (1.97)

BODY ALIGNMENT

< SERVICE DATA AND SPECIFICATIONS (SDS)

Points	Coordinates			Remarks	Points	Coordinates			Remarks
	X	Y	Z			X	Y	Z	
G, g	±437.5 (±17.224)	1760.0 (69.291)	81.2 (3.197)	Hole φ16 (0.63)	P, p	±531.2 (±20.913)	2642.7 (104.043)	515.6 (20.299)	Hole φ64 (2.52)
H, h	±604.0 (±23.779)	2340.5 (92.145)	128.3 (5.051)	Hole φ13 (0.51)					

Underbody (AWD)

INFOID:000000005172880

Measurement

Dimensions marked with "*" indicate symmetrically identical dimensions on both the right and left hand of the vehicle.

A
B
C
D
E
F
G
H
I
J
L
M
N
O
P

BRM

BODY ALIGNMENT

< SERVICE DATA AND SPECIFICATIONS (SDS)

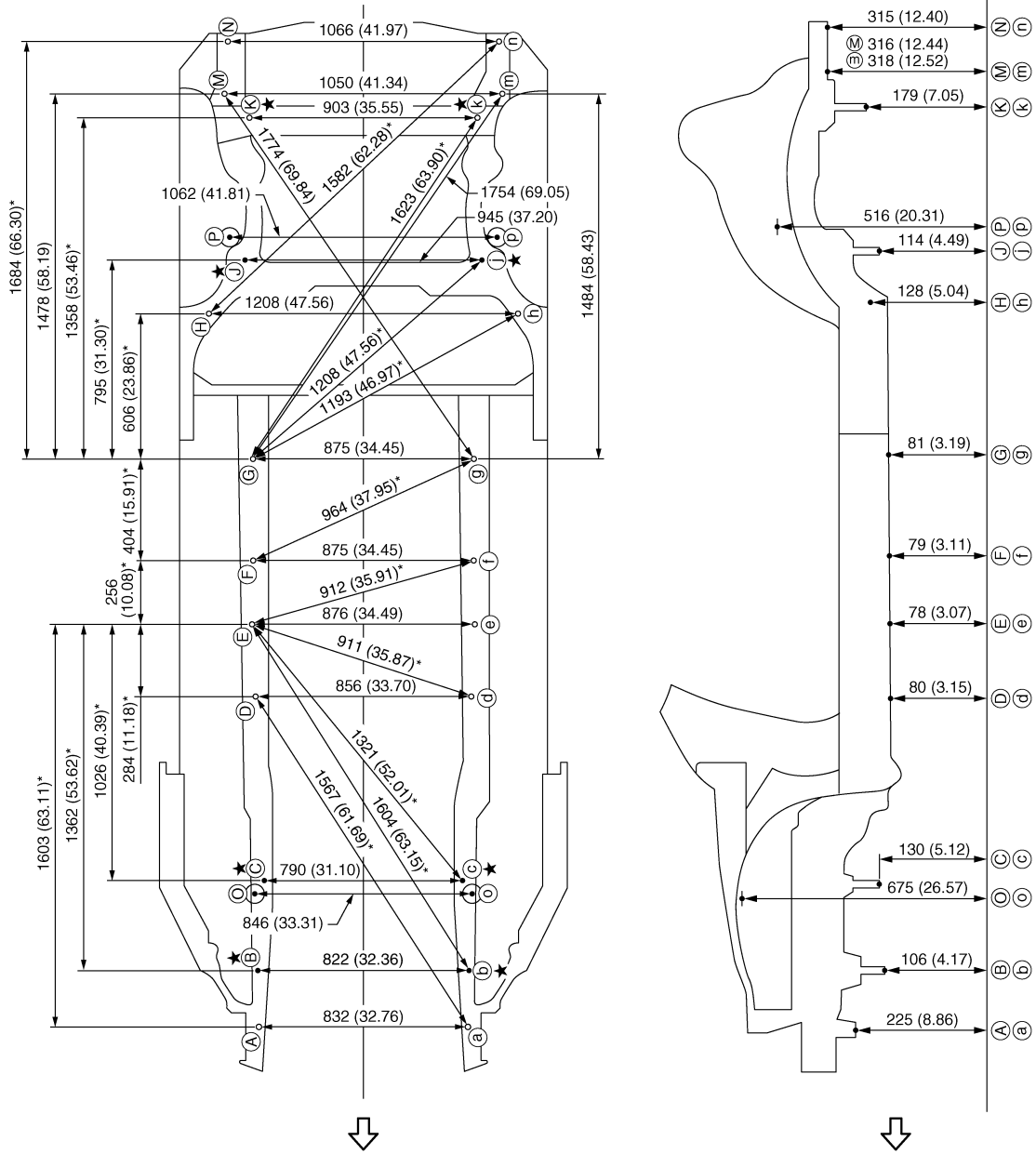

JSKIA0565GB

- Unit: mm (in)
- ↳: Vehicle front
- ★: Bolt head

Measurement Points

BODY ALIGNMENT

< SERVICE DATA AND SPECIFICATIONS (SDS)

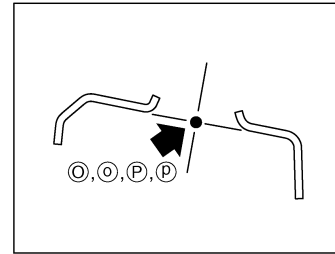
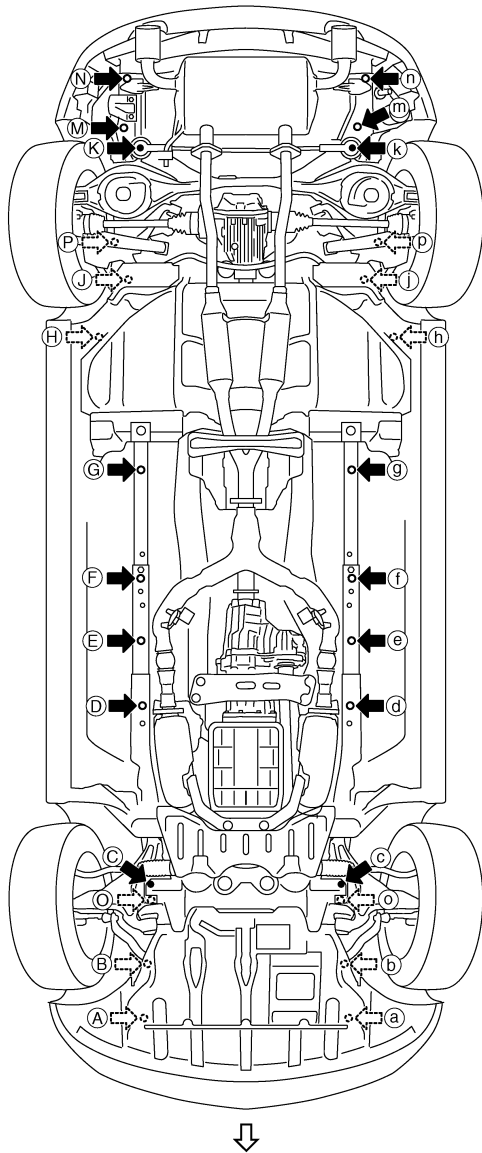

JSKIA0567ZZ

↩ Vehicle front

Unit: mm (in)

Points	Coordinates			Remarks	Points	Coordinates			Remarks
	X	Y	Z			X	Y	Z	
A, a	±416.0 (±16.378)	-496.0 (-19.528)	224.5 (8.839)	Hole φ13 (0.51)	J, j	±472.6 (±18.606)	2553.8 (100.543)	114.0 (4.488)	Bolt head
B, b	±411.0 (±16.181)	-261.0 (-10.276)	105.5 (4.154)	Bolt head	K, k	±451.5 (±17.776)	3113.9 (122.594)	179.1 (7.051)	Bolt head
C, c	±395.0 (±15.551)	76.0 (2.992)	129.5 (5.098)	Bolt head	M	550.0 (21.654)	3214.6 (126.559)	316.4 (12.457)	Hole φ8 (0.31)
D, d	±428.0 (±16.850)	816.6 (32.150)	80.0 (3.150)	Hole 16×18 (0.63×0.71)	m	-500.0 (-19.685)	3223.3 (126.901)	318.0 (12.520)	Hole φ8 (0.31)
E, e	±438.0 (±17.244)	1100.0 (43.307)	78.0 (3.071)	Hole φ16 (0.63)	N, n	±533.0 (±20.984)	3425.0 (134.842)	315.4 (12.417)	Hole φ16 (0.63)
F, f	±437.5 (±17.224)	1355.9 (53.382)	78.8 (3.102)	Hole φ16 (0.63)	O, o	±423.0 (±16.654)	38.0 (1.496)	674.5 (26.555)	Hole φ50 (1.97)

A
B
C
D
E
F
G
H
I
J
K
L
M
N
O
P

BRM

BODY ALIGNMENT

< SERVICE DATA AND SPECIFICATIONS (SDS)

Points	Coordinates			Remarks	Points	Coordinates			Remarks
	X	Y	Z			X	Y	Z	
G, g	±437.5 (±17.224)	1760.0 (69.291)	81.2 (3.197)	Hole φ16 (0.63)	P, p	±531.2 (±20.913)	2642.7 (104.043)	515.6 (20.299)	Hole φ64 (2.52)
H, h	±604.0 (±23.779)	2340.5 (92.145)	128.3 (5.051)	Hole φ13 (0.51)					

Passenger Compartment

INFOID:000000005172881

Measurement

Dimensions marked with "*" indicate symmetrically identical dimensions on both the right and left hand of the vehicle.

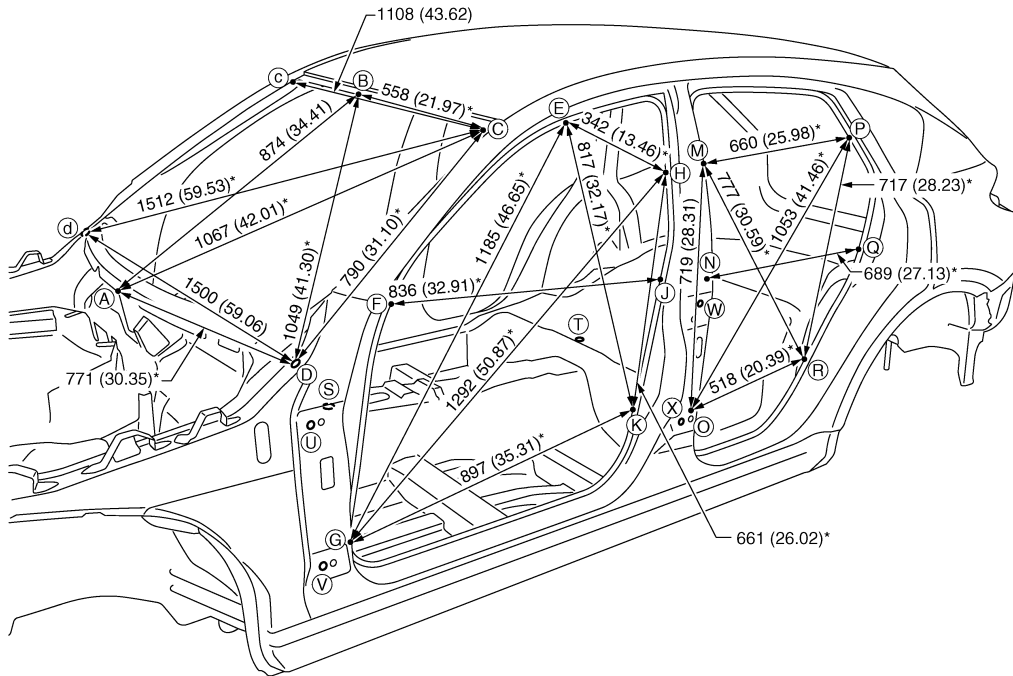

JSKIA0568GB

Unit: mm (in)

«The others»

Unit: mm (in)

Point	Dimension	Memo	Point	Dimension	Memo	Point	Dimension	Memo	Point	Dimension	Memo
E - e	1183 (46.57)		J - j	1459 (57.44)		P - p	1280 (50.39)		T - N	864 (34.02)*	
E - g	1776 (69.92)*		K - k	1485 (58.46)		P - r	1547 (60.91)*		T - O	752 (29.61)*	
E - h	1302 (51.26)*		M - m	1325 (52.17)		Q - q	1436 (56.54)		T - P	1136 (44.72)*	
E - k	1557 (61.30)*		M - o	1562 (61.50)*		R - r	1469 (57.83)		T - Q	994 (39.13)*	
F - f	1424 (56.06)		M - p	1460 (57.48)*		S - E	1206 (47.48)*		T - R	805 (31.69)*	
F - j	1666 (65.59)*		M - r	1597 (62.87)*		S - F	894 (35.20)*		U - W	1182 (46.54)*	
G - g	1478 (58.19)		N - n	1452 (57.17)		S - G	764 (30.08)*		U - X	1182 (46.54)*	
G - h	1907 (75.08)*		N - q	1600 (62.99)*		S - H	1311 (51.61)*		V - W	1247 (49.09)*	

BODY ALIGNMENT

< SERVICE DATA AND SPECIFICATIONS (SDS)

Point	Dimension	Memo	Point	Dimension	Memo	Point	Dimension	Memo	Point	Dimension	Memo
G - k	1732 (68.19)*		O - o	1451 (57.13)		S - J	1168 (45.98)*		V - X	1150 (45.28)*	
H - h	1333 (52.48)		O - p	1722 (67.80)*		S - K	1024 (40.31)*				
H - k	1554 (61.18)*		O - r	1550 (61.02)*		T - M	995 (39.17)*				

Measurement Points

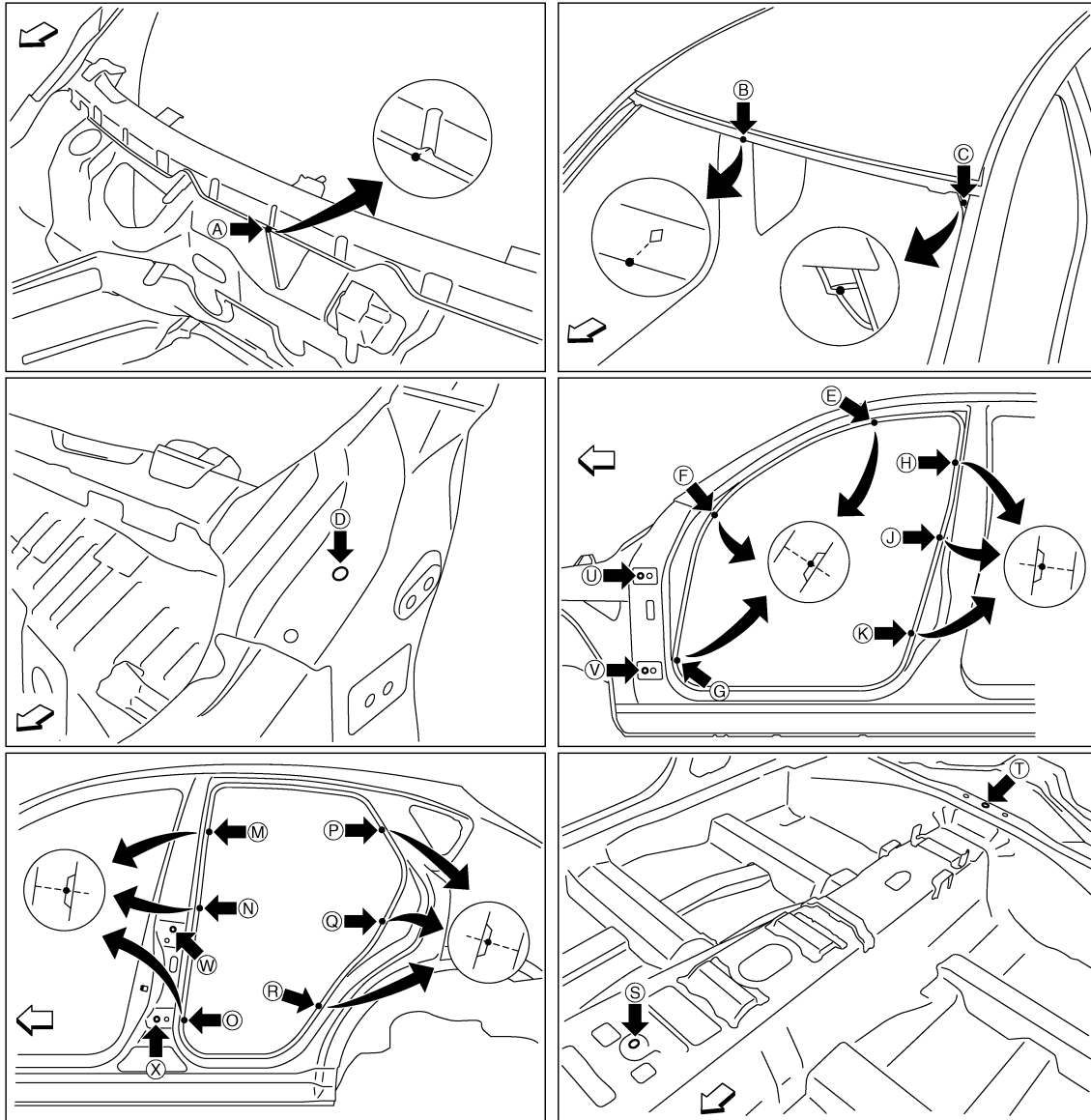

JSKIA0569ZZ

↶ Vehicle front

Unit: mm (in)

Point	Material	Point	Material
A	Upper dash crossmember flange end of center positioning mark	H, h, J, j, K, k, M, m, N, n, O, o	Center pillar indent
B	Roof flange end of center positioning mark	P, p, Q, q, R, r	Rear fender indent

BODY ALIGNMENT

< SERVICE DATA AND SPECIFICATIONS (SDS)

Point	Material	Point	Material
C, c	Front pillar reinforcement joggle	S	Trans control reinforcement hole center of center positioning mark 12×14 (0.47×0.55)
D, d	Hood hinge installing hole center $\phi 6$ (0.24)	T	Rear seat crossmember reinforcement hole center of center positioning mark $\phi 5$ (0.20)
E, e, F, f, G, g	Front pillar indent	U, u, V, v, W, w, X, x	Door hinge installing hole center U, u, V, v, X, x: $\phi 12$ (0.47) W, w: $\phi 9$ (0.35)

Rear Body

INFOID:000000005172882

Measurement

Dimensions marked with "*" indicate symmetrically identical dimensions on both the right and left hand of the vehicle.

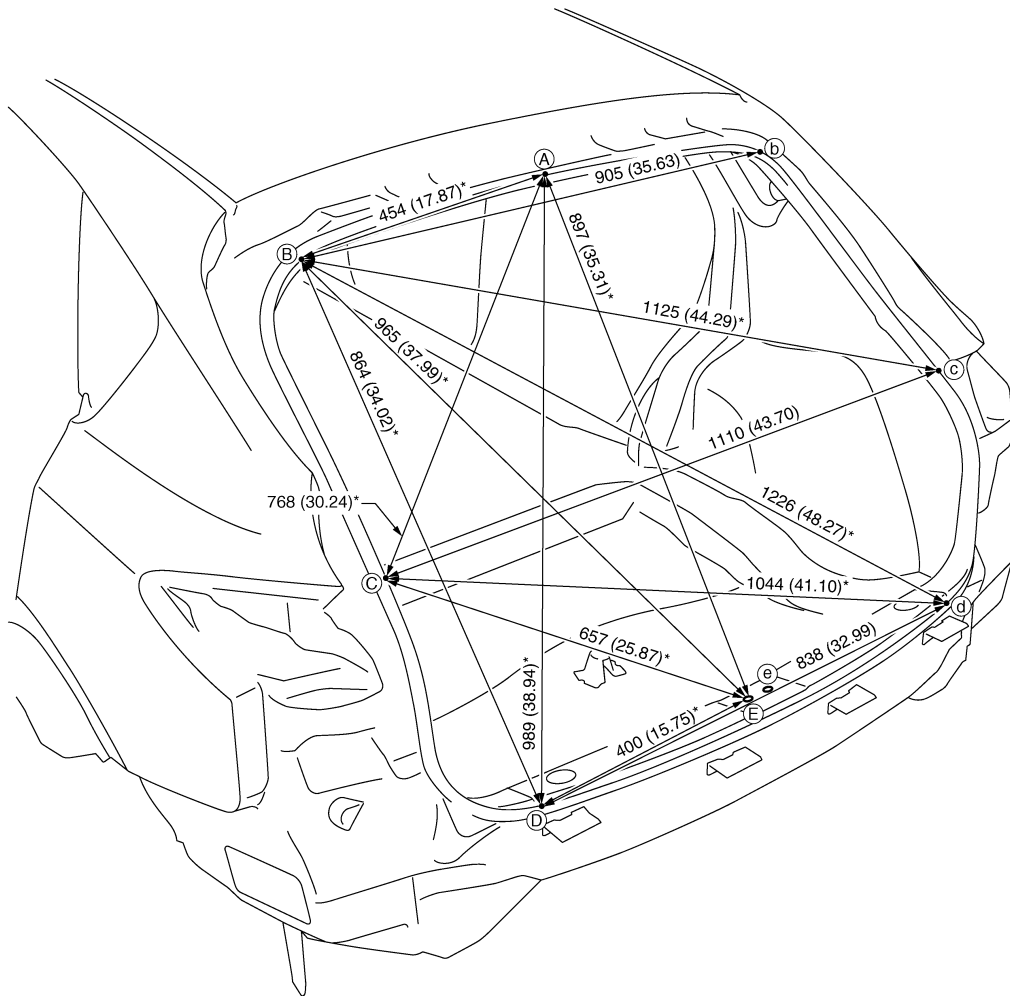

JSKIA0570GB

Unit: mm (in)

Measurement Points

BODY ALIGNMENT

< SERVICE DATA AND SPECIFICATIONS (SDS)

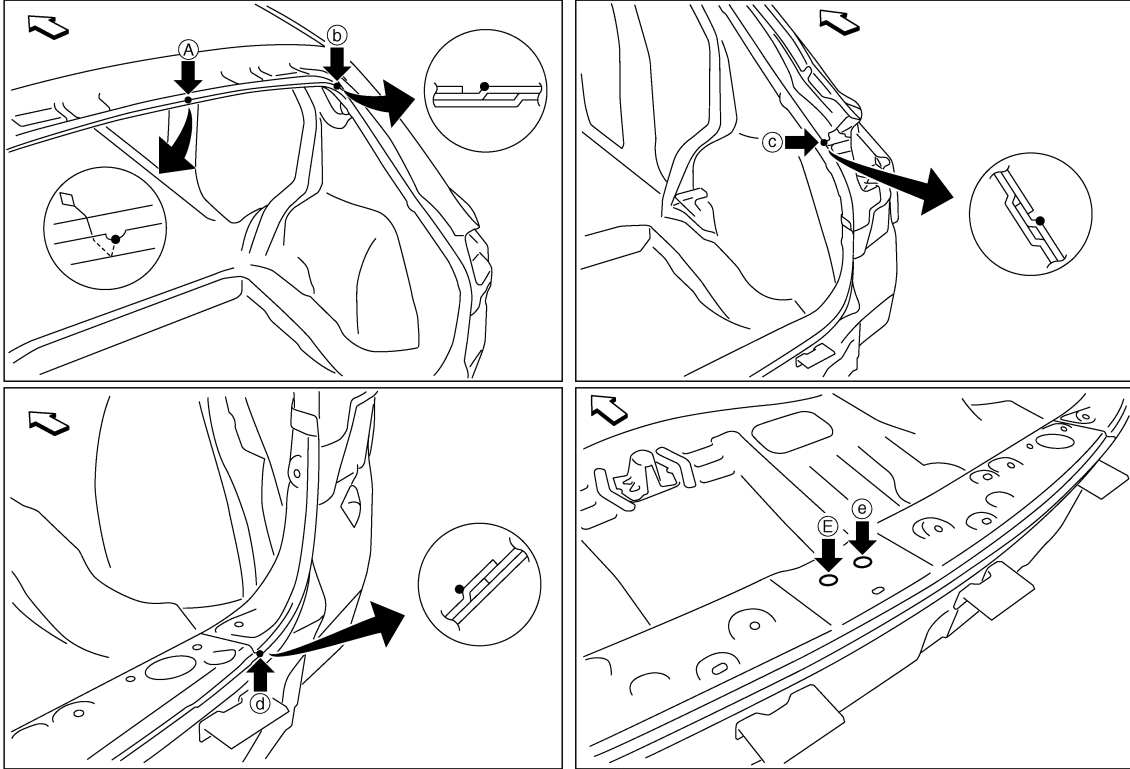

JSKIA0571ZZ

←: Vehicle front

Unit: mm (in)

Point	Material	Point	Material
A	Roof indent of center positioning mark	D, d	Rear end crossmember joggle
B, b	Back pillar main joggle	E, e	Back door striker installing hole center φ14 (0.55)
C, c	Back pillar main center joggle		

A
B
C
D
E
F
G
H
I
J
K
L
M
N
O
P

BRM

LOCATION OF PLASTIC PARTS

< SERVICE DATA AND SPECIFICATIONS (SDS)

LOCATION OF PLASTIC PARTS

Precautions for Plastics

INFOID:000000005172883

Abbreviation	Material name	Heatresisting temperature °C (°F)	Resistance to gasoline and solvents	Other cautions
PE	Polyethylene	60 (140)	Gasoline and most solvents are harmless if applied for a very short time (wipe out quickly).	Flammable
ABS	Acrylonitrile Butadiene Styrene	80 (176)	Avoid gasoline and solvents.	—
EPM/EPDM	Ethylene Propylene (Diene) copolymer	80 (176)	Gasoline and most solvents are harmless if applied for a very short time (wipe out quickly).	Flammable
PS	Polystyrene	80 (176)	Avoid solvents.	Flammable
PVC	Poly Vinyl Chloride	80 (176)	Gasoline and most solvents are harmless if applied for a very short time (wipe out quickly).	Poisonous gas is emitted when burned.
TPO	Thermoplastic Olefine	80 (176)	↑	Flammable
AAS	Acrylonitrile Acrylic Styrene	85 (185)	Avoid gasoline and solvents.	—
PMMA	Poly Methyl Methacrylate	85 (185)	↑	—
EVAC	Ethylene Vinyl Acetate	90 (194)	↑	—
PP	Polypropylene	90 (194)	Gasoline and most solvents are harmless if applied for a very short time (wipe out quickly).	Flammable, avoid battery acid.
PUR	Polyurethane	90 (194)	Avoid gasoline and solvents.	—
UP	Unsaturated Polyester	90 (194)	↑	Flammable
ASA	Acrylonitrile Styrene Acrylate	100 (212)	↑	Flammable
PPE	Poly Phenylene Ether	110 (230)	↑	—
TPU	Thermoplastic Urethane	110 (230)	↑	—
PBT+PC	Poly Butylene Terephthalate + Polycarbonate	120 (248)	↑	Flammable
PC	Polycarbonate	120 (248)	↑	—
POM	Poly Oxymethylene	120 (248)	↑	Avoid battery acid.
PA	Polyamide	140 (284)	↑	Avoid immersing in water.
PBT	Poly Butylene Terephthalate	140 (284)	↑	—
PAR	Polyarylate	180 (356)	↑	—
PET	Polyethylene terephthalate	180 (356)	↑	—
PEI	Polyetherimide	200 (392)	↑	—

CAUTION:

- When repairing and painting a portion of the body adjacent to plastic parts, consider their characteristics (influence of heat and solvent) and remove them if necessary or take suitable measures to protect them.
- Plastic parts should be repaired and painted using methods suiting the materials' characteristics.

LOCATION OF PLASTIC PARTS

< SERVICE DATA AND SPECIFICATIONS (SDS)

Location of Plastic Parts

INFOID:000000005172884

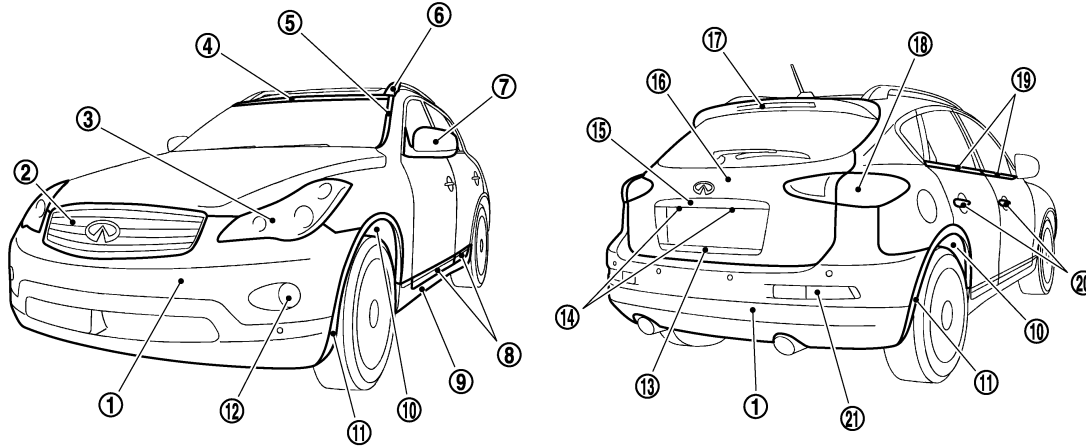

JSKIA0580ZZ

Component		Material	Component		Material	
1	Bumper fascia	PP + EPM	13	Back door finisher	ABS	
2	Front grille	ABS	14	License plate lamp	Lens	PC
3	Front combination lamp	Lens			Housing	PC
		Housing	PP	15	Center back door finisher	ABS
4	Upper windshield molding	TPO	16	Back door	PP + EPM	
5	Roof side molding	PVC + Stainless	17	High mount stop lamp	Lens	PMMA
6	Roof rack cover				ABS	Housing
7	Door outside mirror	Cover	18	Rear combination lamp (Rear Fender)	Lens	PMMA
		Housing			Housing	ASA
		Base			PA	Rear combination lamp (Back door)
8	Side guard molding	Body	PP	Housing	ASA	
		Chrome part	ABS	19	Door outside molding	PP + TPO + Stainless
9	Center mudguard	PP	20	Door outside handle	PC + ABS	
10	Fender protector	Front	21	Rear combination lamp (Rear bumper)	Lens	PC
		Rear			PET	Housing
11	Fillet molding	PP + EPM				
12	Front fog lamp	Lens			Glass	
		Housing			PBT + ASA + Glass fiber	

A
B
C
D
E
F
G
H
I
J
K
L
M
N
O
P

BRM

LOCATION OF PLASTIC PARTS

< SERVICE DATA AND SPECIFICATIONS (SDS)

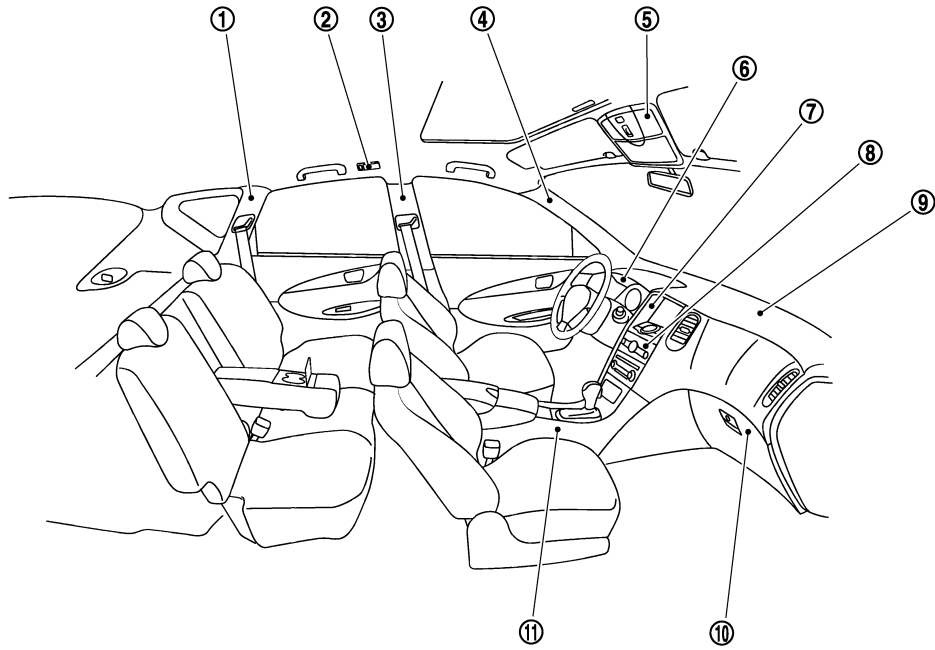

JSKIA0581ZZ

Component		Material	Component		Material	
1	Luggage side finisher	PP	7	Cluster lid D	PC + ABS	
2	Personal lamp	Lens	PC	8	Cluster lid C	PC + ABS
		Housing	PP			
3	Center pillar garnish	PP	9	Instrument panel	Skin	TPU
					Pad	PP
4	Front pillar garnish	PP	10	Glove box	Skin	PVC
					Core	ABS
5	Map lamp	Lens	PC	11	Console body	PC + ABS
		Housing	PP			
6	Cluster lid A	PP				