

# MWI

## SECTION

# METER, WARNING LAMP & INDICATOR

A  
B  
C  
D  
E  
F  
G  
H  
I  
J  
K  
L  
M  
O  
P

## CONTENTS

<b>BASIC INSPECTION</b> .....	4	<b>ODO/TRIP METER</b> .....	20
<b>DIAGNOSIS AND REPAIR WORKFLOW</b> .....	4	ODO/TRIP METER : System Diagram .....	20
Work flow .....	4	ODO/TRIP METER : System Description .....	20
<b>SYSTEM DESCRIPTION</b> .....	6	ODO/TRIP METER : Component Parts Location .....	21
<b>METER SYSTEM</b> .....	6	ODO/TRIP METER : Component Description .....	22
<b>METER SYSTEM</b> .....	6	<b>SHIFT POSITION INDICATOR</b> .....	22
METER SYSTEM : System Diagram .....	6	SHIFT POSITION INDICATOR : System Diagram .....	22
METER SYSTEM : System Description .....	6	SHIFT POSITION INDICATOR : System Description .....	22
METER SYSTEM : Component Parts Location .....	10	SHIFT POSITION INDICATOR : Component Parts Location .....	23
METER SYSTEM : Component Description .....	11	SHIFT POSITION INDICATOR : Component Description .....	24
<b>SPEEDOMETER</b> .....	11	<b>WARNING LAMPS/INDICATOR LAMPS</b> .....	24
SPEEDOMETER : System Diagram .....	12	WARNING LAMPS/INDICATOR LAMPS : System Diagram .....	24
SPEEDOMETER : System Description .....	12	WARNING LAMPS/INDICATOR LAMPS : System Description .....	24
SPEEDOMETER : Component Parts Location .....	13	WARNING LAMPS/INDICATOR LAMPS : Component Parts Location .....	25
SPEEDOMETER : Component Description .....	14	WARNING LAMPS/INDICATOR LAMPS : Component Description .....	26
<b>TACHOMETER</b> .....	14	<b>METER ILLUMINATION CONTROL</b> .....	26
TACHOMETER : System Diagram .....	14	METER ILLUMINATION CONTROL : System Diagram .....	26
TACHOMETER : System Description .....	14	METER ILLUMINATION CONTROL : System Description .....	26
TACHOMETER : Component Parts Location .....	15	METER ILLUMINATION CONTROL : Component Parts Location .....	28
TACHOMETER : Component Description .....	16	METER ILLUMINATION CONTROL : Component Description .....	29
<b>ENGINE COOLANT TEMPERATURE GAUGE</b> .....	16	<b>INFORMATION DISPLAY</b> .....	29
ENGINE COOLANT TEMPERATURE GAUGE : System Diagram .....	16	INFORMATION DISPLAY : System Diagram .....	29
ENGINE COOLANT TEMPERATURE GAUGE : System Description .....	16	INFORMATION DISPLAY : System Description .....	29
ENGINE COOLANT TEMPERATURE GAUGE : Component Parts Location .....	17	INFORMATION DISPLAY : Component Parts Location .....	32
ENGINE COOLANT TEMPERATURE GAUGE : Component Description .....	18	INFORMATION DISPLAY : Component Description .....	33
<b>FUEL GAUGE</b> .....	18		
FUEL GAUGE : System Diagram .....	18		
FUEL GAUGE : System Description .....	18		
FUEL GAUGE : Component Parts Location .....	19		
FUEL GAUGE : Component Description .....	20		

MWI

<b>COMPASS</b> .....	<b>34</b>	<b>IPDM E/R (INTELLIGENT POWER DISTRIBUTION MODULE ENGINE ROOM)</b> .....	<b>54</b>
Description .....	34	IPDM E/R (INTELLIGENT POWER DISTRIBUTION MODULE ENGINE ROOM) : Diagnosis Procedure .....	54
Component Parts Location .....	36		
Special Repair Requirement .....	36		
<b>CLOCK</b> .....	<b>37</b>	<b>FUEL LEVEL SENSOR SIGNAL CIRCUIT</b> .....	<b>56</b>
Component Parts Location .....	37	Description .....	56
<b>DIAGNOSIS SYSTEM (METER)</b> .....	<b>38</b>	Component Function Check .....	56
Diagnosis Description .....	38	Diagnosis Procedure .....	56
<b>DIAGNOSIS SYSTEM (UNIFIED METER AND A/C AMP.)</b> .....	<b>40</b>	Component Inspection .....	57
CONSULT-III Function (METER/M&A) .....	40	<b>METER CONTROL SWITCH SIGNAL CIRCUIT</b> .....	<b>59</b>
<b>DTC/CIRCUIT DIAGNOSIS</b> .....	<b>44</b>	Description .....	59
<b>U1000 CAN COMM CIRCUIT</b> .....	<b>44</b>	Diagnosis Procedure .....	59
Description .....	44	Component Inspection .....	60
DTC Logic .....	44	<b>TRIP A/B RESET SWITCH SIGNAL CIRCUIT..</b>	<b>61</b>
Diagnosis Procedure .....	44	Description .....	61
<b>U1010 CONTROL UNIT (CAN)</b> .....	<b>45</b>	Diagnosis Procedure .....	61
Description .....	45	Component Inspection .....	61
DTC Logic .....	45	<b>OIL PRESSURE SWITCH SIGNAL CIRCUIT ...</b>	<b>63</b>
Diagnosis Procedure .....	45	Description .....	63
<b>B2201 COMMUNICATION ERROR 1</b> .....	<b>46</b>	Component Function Check .....	63
Description .....	46	Diagnosis Procedure .....	63
DTC Logic .....	46	Component Inspection .....	63
Diagnosis Procedure .....	46	<b>PARKING BRAKE SWITCH SIGNAL CIRCUIT</b> .....	<b>64</b>
<b>B2202 COMMUNICATION ERROR 2</b> .....	<b>48</b>	Description .....	64
Description .....	48	Diagnosis Procedure .....	64
DTC Logic .....	48	Component Inspection .....	64
Diagnosis Procedure .....	48	<b>WASHER LEVEL SWITCH SIGNAL CIRCUIT..</b>	<b>66</b>
<b>B2205 VEHICLE SPEED</b> .....	<b>50</b>	Description .....	66
Description .....	50	Diagnosis Procedure .....	66
DTC Logic .....	50	Component Inspection .....	66
Diagnosis Procedure .....	50	<b>COMPASS</b> .....	<b>67</b>
<b>B2267 ENGINE SPEED</b> .....	<b>51</b>	Wiring Diagram - COMPASS - .....	67
Description .....	51	<b>CLOCK</b> .....	<b>69</b>
DTC Logic .....	51	Wiring Diagram - CLOCK - .....	69
Diagnosis Procedure .....	51	<b>ECU DIAGNOSIS INFORMATION</b> .....	<b>71</b>
<b>B2268 WATER TEMP</b> .....	<b>52</b>	<b>COMBINATION METER</b> .....	<b>71</b>
Description .....	52	Reference Value .....	71
DTC Logic .....	52	Wiring Diagram - METER - .....	74
Diagnosis Procedure .....	52	Fail-Safe .....	82
<b>POWER SUPPLY AND GROUND CIRCUIT</b> ....	<b>53</b>	DTC Index .....	83
<b>COMBINATION METER</b> .....	<b>53</b>	<b>UNIFIED METER AND A/C AMP.</b> .....	<b>84</b>
COMBINATION METER : Diagnosis Procedure ...	53	Reference Value .....	84
<b>UNIFIED METER AND A/C AMP.</b> .....	<b>53</b>	Wiring Diagram - METER - .....	91
UNIFIED METER AND A/C AMP. : Diagnosis Procedure .....	53	Fail-Safe .....	99
		DTC Index .....	100

<b>IPDM E/R (INTELLIGENT POWER DISTRIBUTION MODULE ENGINE ROOM) .....</b>	<b>101</b>	Description .....	121	
Reference Value .....	101	Diagnosis Procedure .....	121	A
Wiring Diagram - IPDM E/R - .....	108	<b>THE AMBIENT TEMPERATURE DISPLAY IS INCORRECT .....</b>	<b>122</b>	B
Fail-safe .....	111	Description .....	122	
DTC Index .....	113	Diagnosis Procedure .....	122	
<b>SYMPTOM DIAGNOSIS .....</b>	<b>114</b>	<b>NORMAL OPERATING CONDITION .....</b>	<b>123</b>	C
<b>THE FUEL GAUGE POINTER DOES NOT MOVE .....</b>	<b>114</b>	<b>COMPASS .....</b>	<b>123</b>	D
Description .....	114	COMPASS : Description .....	123	
Diagnosis Procedure .....	114	<b>INFORMATION DISPLAY .....</b>	<b>123</b>	E
<b>THE METER CONTROL SWITCH IS INOPERATIVE .....</b>	<b>115</b>	INFORMATION DISPLAY : Description .....	123	
Description .....	115	<b>PRECAUTION .....</b>	<b>124</b>	
Diagnosis Procedure .....	115	<b>PRECAUTIONS .....</b>	<b>124</b>	F
<b>THE TRIP A/B RESET SWITCH IS INOPERATIVE .....</b>	<b>116</b>	Precaution for Supplemental Restraint System (SRS) "AIR BAG" and "SEAT BELT PRE-TENSIONER" .....	124	
Description .....	116	<b>REMOVAL AND INSTALLATION .....</b>	<b>125</b>	G
Diagnosis Procedure .....	116	<b>COMBINATION METER .....</b>	<b>125</b>	H
<b>THE OIL PRESSURE WARNING LAMP DOES NOT TURN ON .....</b>	<b>117</b>	Exploded View .....	125	
Description .....	117	Removal and Installation .....	125	
Diagnosis Procedure .....	117	Disassembly and Assembly .....	125	
<b>THE OIL PRESSURE WARNING LAMP DOES NOT TURN OFF .....</b>	<b>118</b>	<b>UNIFIED METER AND A/C AMP. ....</b>	<b>126</b>	I
Description .....	118	Exploded View .....	126	
Diagnosis Procedure .....	118	Removal and Installation .....	126	J
<b>THE PARKING BRAKE RELEASE WARNING CONTINUES DISPLAYING, OR DOES NOT DISPLAY .....</b>	<b>119</b>	<b>METER CONTROL SWITCH .....</b>	<b>127</b>	K
Description .....	119	Exploded View .....	127	
Diagnosis Procedure .....	119	Removal and Installation .....	127	
<b>THE LOW WASHER FLUID WARNING CONTINUES DISPLAYING, or DOES NOT DISPLAY .....</b>	<b>120</b>	<b>TRIP A/B RESET SWITCH .....</b>	<b>128</b>	L
Description .....	120	Exploded View .....	128	
Diagnosis Procedure .....	120	Removal and Installation .....	128	
<b>THE DOOR OPEN WARNING CONTINUES DISPLAYING, OR DOES NOT DISPLAY .....</b>	<b>121</b>	<b>COMPASS .....</b>	<b>129</b>	M
		Exploded View .....	129	
		Removal and Installation .....	129	
		<b>CLOCK .....</b>	<b>130</b>	MWI
		Exploded View .....	130	
		Removal and Installation .....	130	

# DIAGNOSIS AND REPAIR WORKFLOW

< BASIC INSPECTION >

## BASIC INSPECTION

### DIAGNOSIS AND REPAIR WORKFLOW

Work flow

INFOID:000000004348037

#### OVERALL SEQUENCE

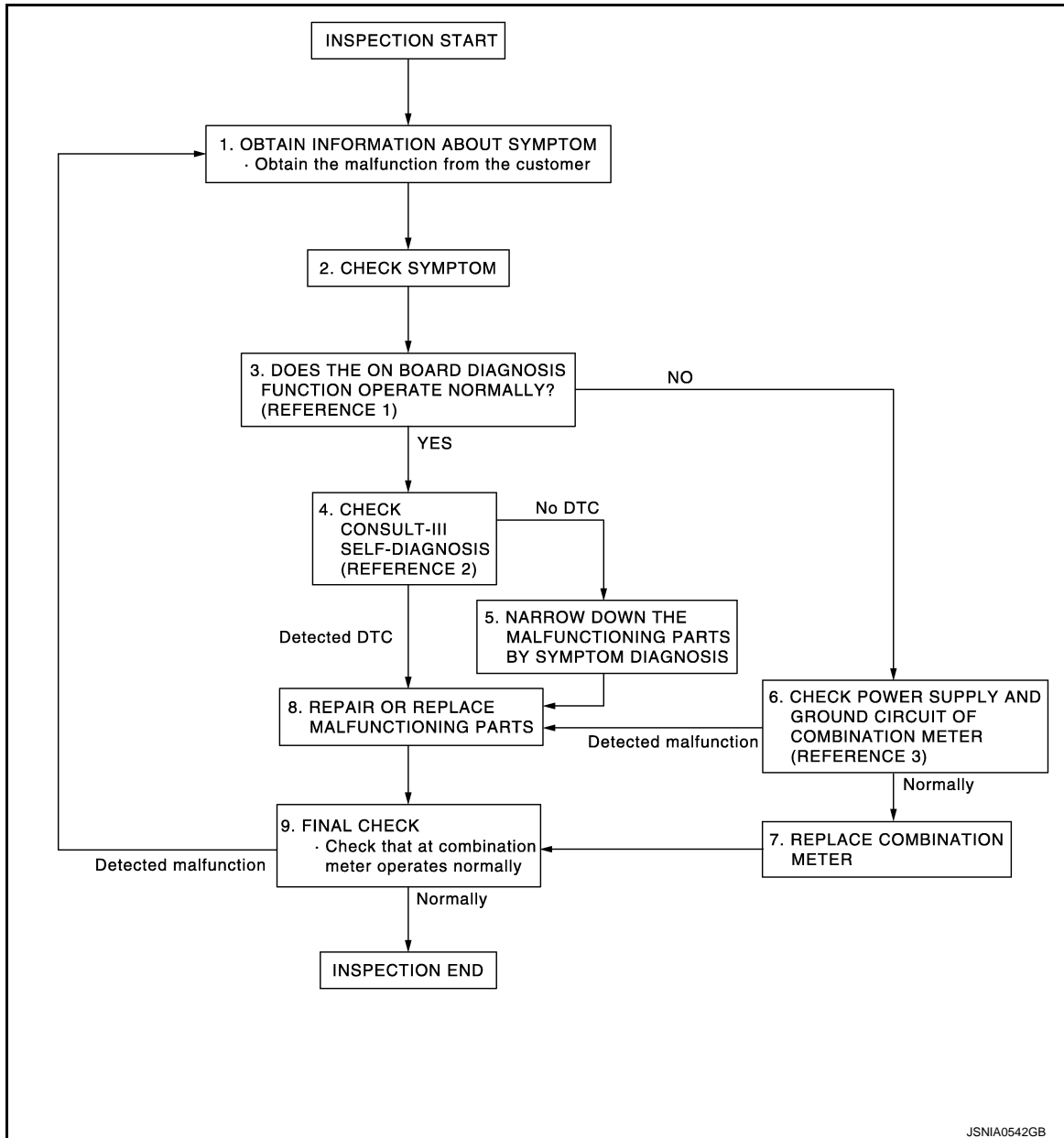

- Reference 1...[MWI-38, "Diagnosis Description"](#).
- Reference 2...[MWI-100, "DTC Index"](#).
- Reference 3...[MWI-53, "COMBINATION METER : Diagnosis Procedure"](#).

#### DETAILED FLOW

##### 1.OBTAIN INFORMATION ABOUT SYMPTOM

Interview the customer to obtain as much information as possible about the conditions and environment under which the malfunction occurred.

>> GO TO 2.

##### 2.CHECK SYMPTOM

# DIAGNOSIS AND REPAIR WORKFLOW

## < BASIC INSPECTION >

---

- Check the symptom based on the information obtained from the customer.
- Check that any other malfunctions are present.

>> GO TO 3.

## 3. CHECK ON BOARD DIAGNOSIS OPERATION

---

Check that the on board diagnosis function operates. Refer to [MWI-38, "Diagnosis Description"](#).

Does the on board diagnosis function operate normally?

YES >> GO TO 4.

NO >> GO TO 6.

## 4. CHECK CONSULT-III SELF-DIAGNOSIS RESULTS

---

Connect CONSULT-III and perform self-diagnosis. Refer to [MWI-40, "CONSULT-III Function \(METER/M&A\)"](#).

Are self-diagnosis results normal?

YES >> GO TO 5.

NO >> GO TO 8.

## 5. NARROW DOWN THE MALFUNCTIONING PARTS BY SYMPTOM DIAGNOSIS

---

Perform symptom diagnosis and narrow down the malfunctioning parts.

>> GO TO 8.

## 6. CHECK COMBINATION METER POWER SUPPLY AND GROUND CIRCUITS

---

Inspect combination meter power supply and ground circuits. Refer to [MWI-53, "COMBINATION METER : Diagnosis Procedure"](#).

Is the inspection result normal?

YES >> GO TO 7.

NO >> GO TO 8.

## 7. REPLACE COMBINATION METER

---

Replace combination meter.

>> GO TO 9.

## 8. REPAIR OR REPLACE MALFUNCTIONING PARTS

---

Repair or replace the malfunctioning parts.

### **NOTE:**

If DTC is displayed, erase DTC after repair or replace malfunctioning parts.

>> GO TO 9.

## 9. FINAL CHECK

---

Check that the combination meter operates normally.

Do they operate normally?

YES >> INSPECTION END

NO >> GO TO 1.

A

B

C

D

E

F

G

H

I

J

K

L

M

MWI

O

P

# METER SYSTEM

< SYSTEM DESCRIPTION >

## SYSTEM DESCRIPTION

### METER SYSTEM

### METER SYSTEM

### METER SYSTEM : System Diagram

INFOID:000000004348038

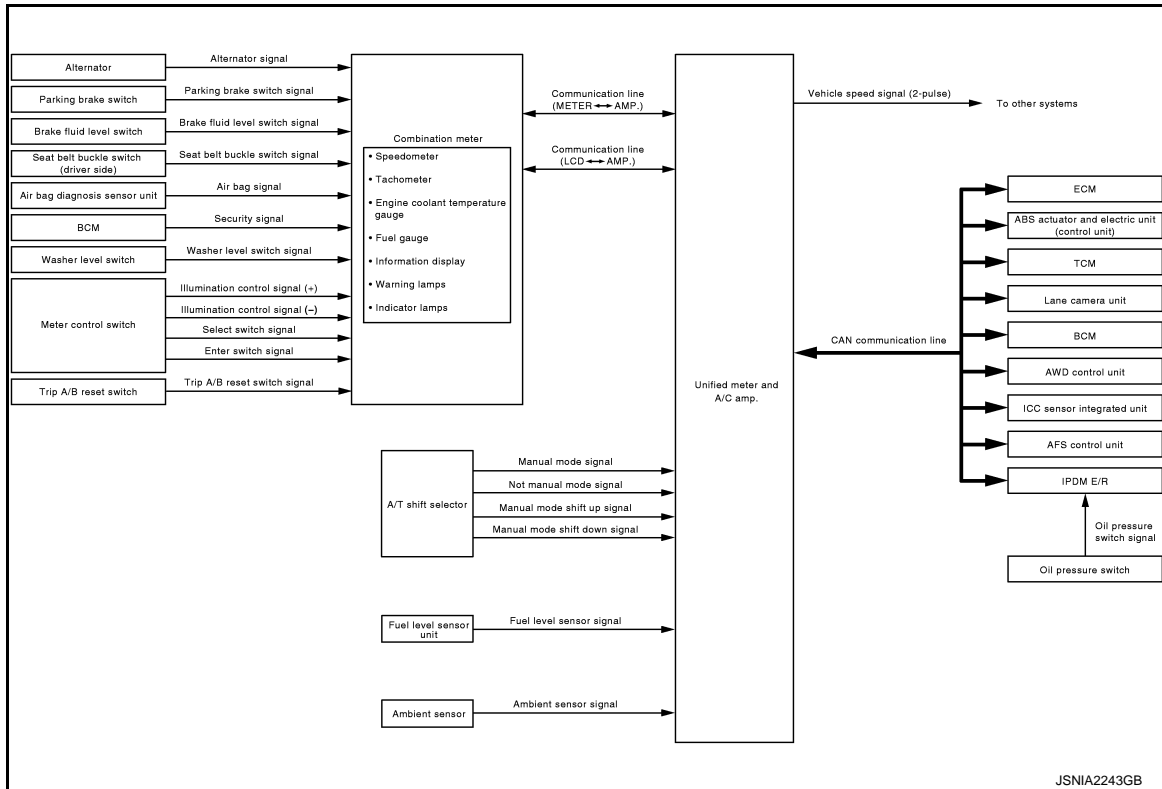

### METER SYSTEM : System Description

INFOID:000000004348039

#### COMBINATION METER

- The combination meter retrieves the information required for controlling the operations of the meters, indicator lamps/warning lamps and information display from the communication signals from the unified meter and A/C amp. and the signals from various switches and sensors.
- The combination meter incorporates a trip computer that displays warnings and messages on the information display according to the information received from various units.
- The combination meter incorporates a buzzer function that sounds an audible alarm with the integrated buzzer device. Refer to [WCS-5. "WARNING CHIME SYSTEM : System Description"](#) for further details.
- The combination meter integrates the meter circuit check function and the segment check function that checks the information display operation.

#### UNIFIED METER AND A/C AMP.

- Receives information required by the combination meter from various units via CAN communication line and transmits it to the combination meter with communication line.
- The unified meter and A/C amp. incorporates a power saving control function that reduces the power consumption according to the vehicle status. Refer to [BCS-13. "System Description"](#) for details.
- The unified meter and A/C amp. incorporates a diagnosis function that allows the technician to perform diagnoses with CONSULT-III.

# METER SYSTEM

## < SYSTEM DESCRIPTION >

Between unified meter and A/C amp. and combination meter.

Unit	Communication line	Input from combination meter	Output to combination meter	
Unified meter and A/C amp.	Communication line (METER <-> AMP.)	<ul style="list-style-type: none"> <li>• Parking brake switch signal</li> <li>• Washer level switch signal</li> <li>• Meter day/night condition signal</li> <li>• Illumination control switch signal</li> <li>• Refuel status signal</li> <li>• Low fuel warning lamp signal</li> <li>• Odo data signal</li> </ul>	<ul style="list-style-type: none"> <li>• Vehicle speed signal</li> <li>• Turn indicator signal</li> <li>• High beam request signal</li> <li>• Position light request signal</li> <li>• Engine speed signal</li> <li>• Fuel level sensor signal</li> <li>• Engine coolant temperature signal</li> <li>• A/T CHECK indicator signal</li> <li>• Oil pressure switch signal</li> <li>• Door switch signal</li> <li>• Buzzer output signal</li> <li>• AFS OFF indicator lamp signal</li> <li>• Low tire pressure warning lamp signal</li> <li>• AWD warning lamp signal</li> <li>• VDC OFF indicator signal</li> <li>• SLIP indicator signal</li> <li>• ABS warning lamp signal</li> <li>• Brake warning lamp signal</li> <li>• Malfunctioning indicator lamp signal</li> <li>• Master warning signal</li> <li>• ICC warning lamp signal</li> <li>• Lane departure warning lamp signal</li> <li>• LDP ON indicator lamp signal</li> <li>• IBA OFF indicator lamp</li> </ul>	A B C D E F G
	Communication line (LCD <-> AMP.)	<ul style="list-style-type: none"> <li>• Average fuel consumption reset signal</li> <li>• Travel time reset signal</li> <li>• Possible driving distance reset signal</li> <li>• Average vehicle speed reset signal</li> <li>• Select switch signal</li> <li>• Enter switch signal</li> <li>• Trip A/B reset switch signal</li> <li>• Ambient air temperature display signal</li> </ul>	<ul style="list-style-type: none"> <li>• Shift position signal</li> <li>• Meter display signal</li> <li>• Door switch signal</li> <li>• Fuel level sensor signal</li> <li>• Parking brake switch signal</li> <li>• Washer level switch signal</li> <li>• Charge warning signal</li> <li>• Instantaneous fuel consumption display signal</li> <li>• Ambient air temperature display signal</li> <li>• Average fuel consumption display signal</li> <li>• Average vehicle speed display signal</li> <li>• Possible driving distance display signal</li> <li>• Engine speed signal</li> <li>• Vehicle speed signal</li> </ul>	H I J K

### IPDM E/R

- IPDM E/R reads the ON/OFF signals of the oil pressure switch and transmits the oil pressure switch signal to the unified meter and A/C amp. via BCM with the CAN communication line.
- IPDM E/R is equipped with the diagnosis function. It can perform the operation check of oil pressure warning lamp with the auto active test and the diagnosis with CONSULT-III.

### METER CONTROL FUNCTION LIST

X: Applicable

System		Description	Signal source	Via unified meter and A/C amp.
Meter/gauge	Speedometer	Receives vehicle speed signal and indicates vehicle speed.	ABS actuator and electric unit (control unit)	X
	Tachometer	Receives engine speed signal and indicates engine speed.	ECM	X
	Fuel gauge	Receives fuel level sensor signal and indicates fuel level.	Fuel level sensor unit	X
	Engine coolant temperature gauge	Receives engine coolant temperature signal and indicates coolant temperature.	ECM	X

# METER SYSTEM

## < SYSTEM DESCRIPTION >

System		Description	Signal source	Via unified meter and A/C amp.
Warning lamp/ indicator lamp	Oil pressure warning lamp	Receives oil pressure warning lamp signal and illuminates warning lamp.	IPDM E/R	X
	Master warning	Illuminates according to warning output on information display.	—	X
Information display	Door open warning	Receives door switch signals and displays warning.	BCM	X
	Parking brake release warning	Receives parking brake switch signal and vehicle speed signal and displays warnings.	Parking brake switch	
			ABS actuator and electric unit (control unit)	X
	Low fuel warning	Receives fuel gauge signal and displays warning if fuel level decreases to 12 ℓ (3-1/8 US gal, 2-5/8 Imp gal) or less.	Fuel level sensor unit	X
	Low washer fluid warning	Receives washer level switch signal and displays warning.	Washer level switch	
	Low outside temperature warning	Monitors ambient sensor signal and displays warning if ambient temperature decreases to 3°C (37°F) or less. (If enabled)	Ambient sensor	X
	Instantaneous fuel consumption	Calculates instantaneous fuel consumption based on received vehicle speed signals and fuel consumption monitor signal and displays it.	ECM	X
			ABS actuator and electric unit (control unit)	X
	Average fuel consumption	Calculates average fuel consumption in a reset-to-reset interval based on received vehicle speed signals and fuel consumption monitor signal and displays it.	ECM	X
			ABS actuator and electric unit (control unit)	X
	Average vehicle speed	Calculates average vehicle speed in a reset-to-reset interval based on received vehicle speed signals and displays it.	ABS actuator and electric unit (control unit)	X
	Travel time	Displays accumulated key switch ON time from reset to reset.	—	X
	Travel distance	Calculates accumulated travel distance in a reset-to-reset interval based on received vehicle speed signals and displays it.	ABS actuator and electric unit (control unit)	X
Possible driving distance	Calculates possible driving distance based on received fuel consumption monitor signal, vehicle speed signals and fuel level sensor signal and displays it.	ECM	X	
		ABS actuator and electric unit (control unit)	X	
		Fuel level sensor unit	X	
Ambient air temperature	Corrects ambient air temperature value based on received ambient sensor signals and displays it.	Ambient sensor	X	



# METER SYSTEM

< SYSTEM DESCRIPTION >

## ARRANGEMENT OF COMBINATION METER

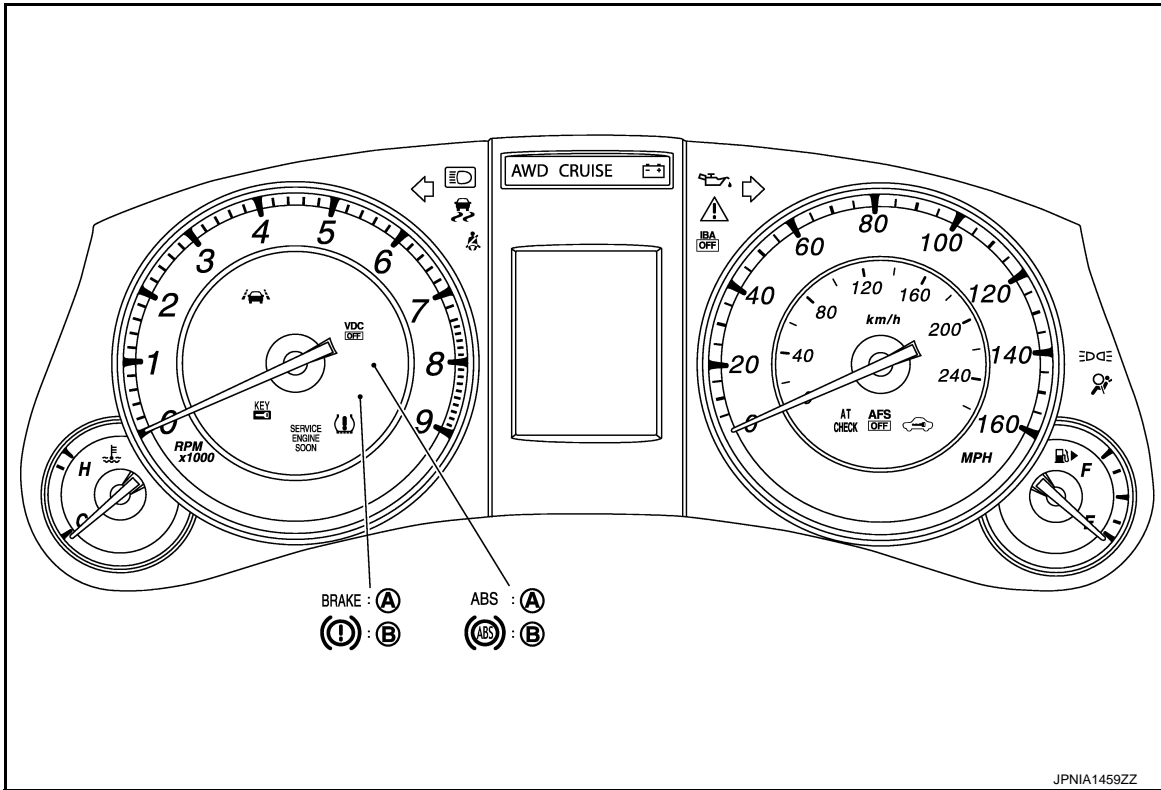

A. U.S.A.

B. Canada

A  
B  
C  
D  
E  
F  
G  
H  
I  
J  
K  
L  
M  
N  
O  
P

MWI

# METER SYSTEM

< SYSTEM DESCRIPTION >

## METER SYSTEM : Component Parts Location

INFOID:000000004348040

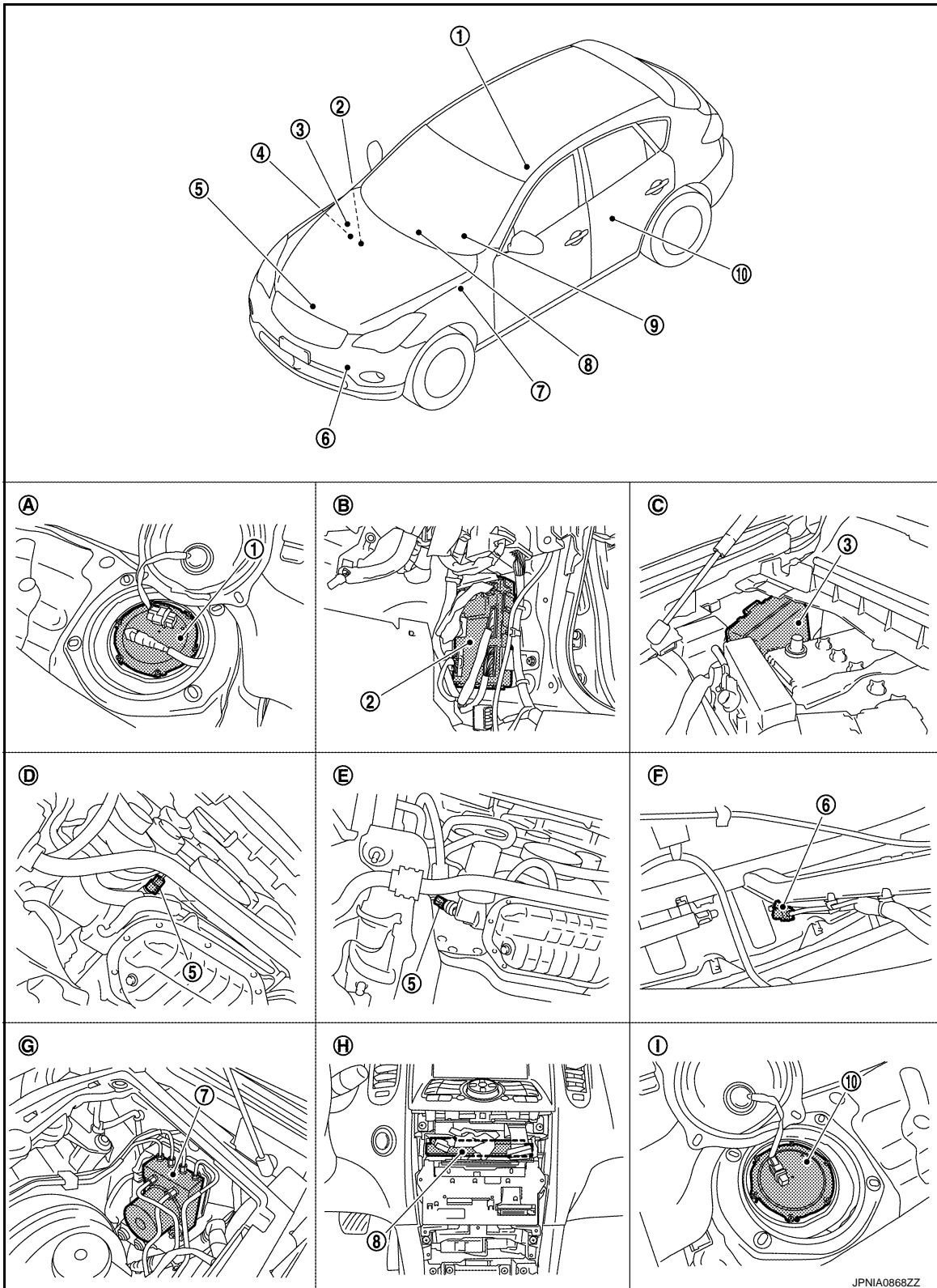

- |  |                        |                   |
|--|------------------------|-------------------|
| 1. Fuel level sensor unit and fuel pump (main) | 2. BCM                 | 3. IPDM E/R       |
| 4. ECM   | 5. Oil pressure switch | 6. Ambient sensor |
- Refer to [EC-24. "Component Parts Location"](#).

JPNIA0868ZZ

# METER SYSTEM

## < SYSTEM DESCRIPTION >

- |  |  |                            |
|--|--|----------------------------|
| 7. ABS actuator and electric unit (control unit) | 8. Unified meter and A/C amp.          | 9. Combination meter       |
| 10. Fuel level sensor unit (sub)                 |  |                            |
| A. Rear seat (inside right)                      | B. Dash side finisher (passenger side) | C. Hoodledge cover (RH)    |
| D. 2WD [oil pan (upper) RH side]                 | E. AWD (oil filter bracket part)       | F. Condenser (front)       |
| G. Hoodledge cover (LH)                          | H. Behind cluster lid C                | I. Rear seat (inside left) |

## METER SYSTEM : Component Description

INFOID:000000004348041

Unit	Description
Combination meter	<p>Controls the following with the signals from the unified meter and A/C amp, switches and sensors.</p> <ul style="list-style-type: none"> <li>• Speedometer</li> <li>• Engine coolant temperature gauge</li> <li>• Warning lamps</li> <li>• Information display</li> <li>• Tachometer</li> <li>• Fuel gauge</li> <li>• Indicator lamps</li> <li>• Warning chime</li> </ul>
Unified meter and A/C amp.	<ul style="list-style-type: none"> <li>• The combination meter receives the necessary information from various units via CAN communication line and transmits them to the unified meter and A/C amp. with the communication line that connects both of them.</li> <li>• Transmits the fuel gauge signal from the fuel gauge unit with the communication line that connects the unified meter and A/C amp. and the combination meter.</li> <li>• Reads the signals from the A/T shift selector transmits them to TCM with CAN communication line.</li> </ul>
IPDM E/R	IPDM E/R reads the ON/OFF signals of the oil pressure switch and transmits the oil pressure switch signal to the unified meter and A/C amp. via BCM with CAN communication line.
Fuel level sensor unit	Refer to <a href="#">MWI-56, "Description"</a> .
Oil pressure switch	Refer to <a href="#">MWI-63, "Description"</a> .
ECM	<p>Transmits the following signals to the unified meter and A/C amp. with CAN communication line.</p> <ul style="list-style-type: none"> <li>• Engine speed signal</li> <li>• Fuel consumption monitor signal</li> <li>• Engine coolant temperature signal</li> </ul>
ABS actuator and electric unit (control unit)	Transmits the vehicle speed signal to the unified meter and A/C amp. with CAN communication line.
BCM	<ul style="list-style-type: none"> <li>• Transmits signals provided by various units to the unified meter and A/C amp. with CAN communication line.</li> <li>• Transmits the security signal to the combination meter.</li> </ul>
A/T shift selector	<p>Transmits the following signals to the unified meter and A/C amp.</p> <ul style="list-style-type: none"> <li>• Manual mode signal</li> <li>• Manual mode shift up signal</li> <li>• Not manual mode signal</li> <li>• Manual mode shift down signal</li> </ul>
TCM	Transmits shift position signal to the unified meter and A/C amp.
Meter control switch	Refer to <a href="#">MWI-59, "Description"</a> .
Trip A/B reset switch	Refer to <a href="#">MWI-61, "Description"</a> .
Washer level switch	Transmits the washer level signal to the combination meter.
Brake fluid level switch	Transmits the brake fluid level switch signal to the combination meter.
Parking brake switch	Refer to <a href="#">MWI-64, "Description"</a> .

## SPEEDOMETER

# METER SYSTEM

< SYSTEM DESCRIPTION >

## SPEEDOMETER : System Diagram

INFOID:000000004348042

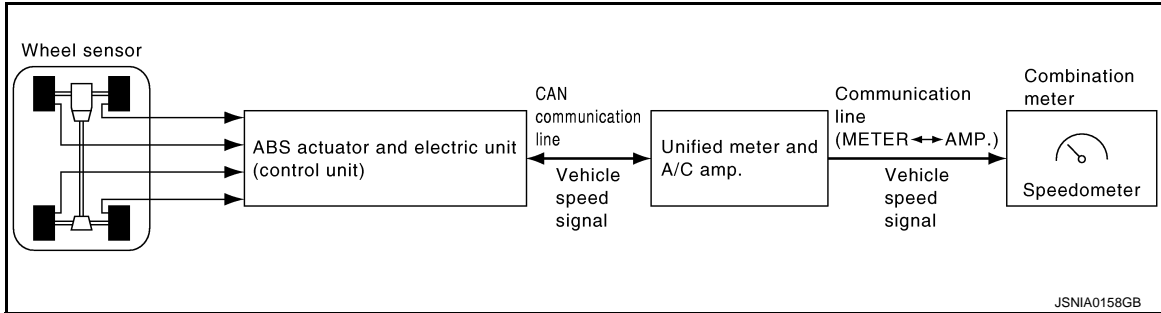

## SPEEDOMETER : System Description

INFOID:000000004348043

- The ABS actuator and electric unit (control unit) converts the pulse signal provided by the wheel sensor to a vehicle speed signal and transmits it to the unified meter and A/C amp. with CAN communication line.
- The unified meter and A/C amp. receives the vehicle speed signal from the ABS actuator and electric unit (control unit) with CAN communication line and transmits it to the combination meter by means of communication line.
- The combination meter indicates the vehicle speed according to the vehicle speed signal received from the unified meter and A/C amp. by means of communication line.

# METER SYSTEM

< SYSTEM DESCRIPTION >

## SPEEDOMETER : Component Parts Location

INFOID:000000004923036

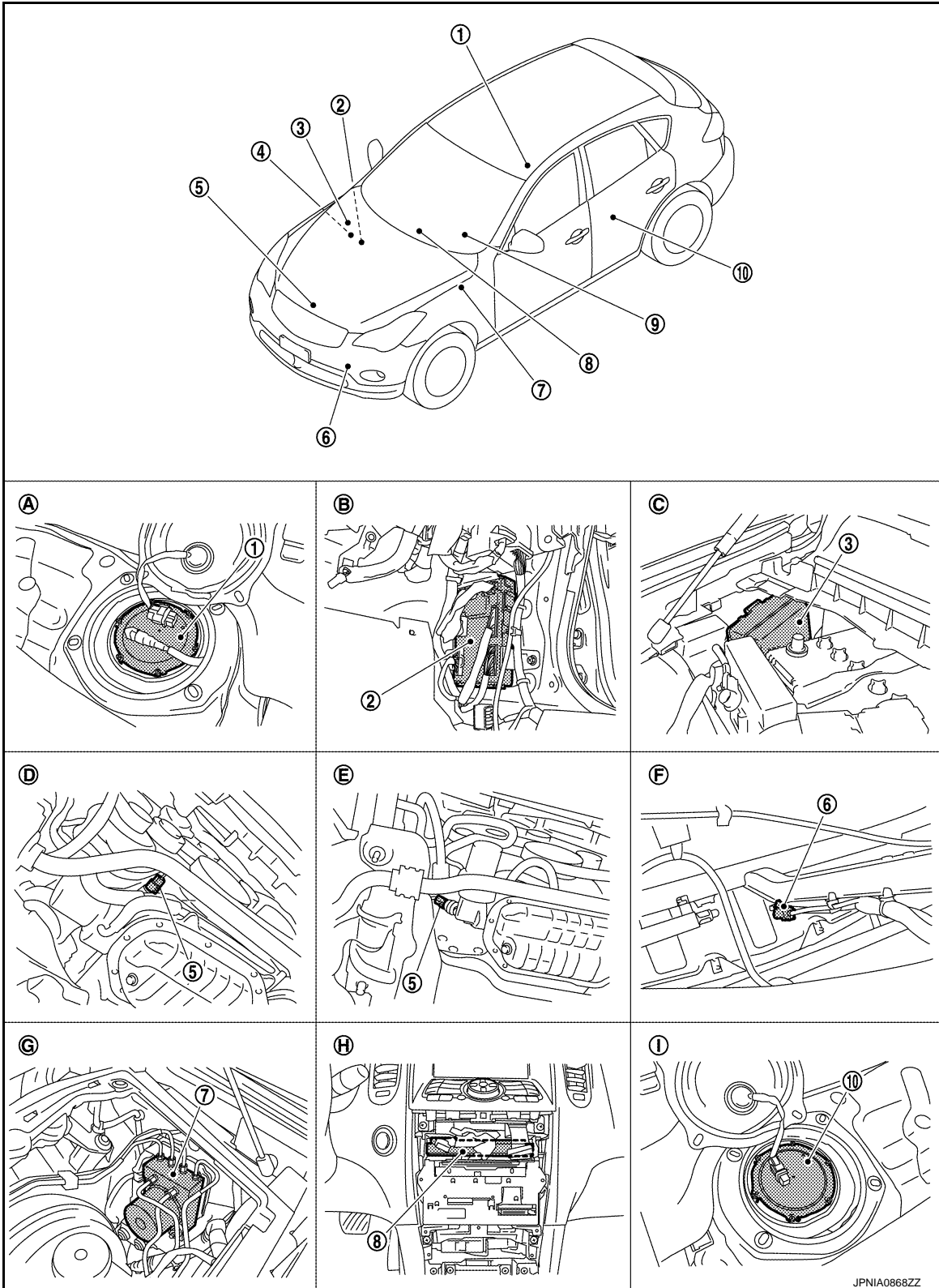

- |  |                        |                   |
|--|------------------------|-------------------|
| 1. Fuel level sensor unit and fuel pump (main)                         | 2. BCM                 | 3. IPDM E/R       |
| 4. ECM<br>Refer to <a href="#">EC-24. "Component Parts Location"</a> . | 5. Oil pressure switch | 6. Ambient sensor |

A  
B  
C  
D  
E  
F  
G  
H  
I  
J  
K  
L  
M  
N  
O  
P

MWI

JPNIA0868ZZ

# METER SYSTEM

## < SYSTEM DESCRIPTION >

- |  |  |                            |
|--|--|----------------------------|
| 7. ABS actuator and electric unit (control unit) | 8. Unified meter and A/C amp.          | 9. Combination meter       |
| 10. Fuel level sensor unit (sub)                 |  |                            |
| A. Rear seat (inside right)                      | B. Dash side finisher (passenger side) | C. Hoodledge cover (RH)    |
| D. 2WD [oil pan (upper) RH side]                 | E. AWD (oil filter bracket part)       | F. Condenser (front)       |
| G. Hoodledge cover (LH)                          | H. Behind cluster lid C                | I. Rear seat (inside left) |

## SPEEDOMETER : Component Description

INFOID:000000004348045

Unit	Description
Combination meter	Indicates the vehicle speed according to the vehicle speed signal received from the unified meter and A/C amp. by means of communication line.
Unified meter and A/C amp.	Transmits the vehicle speed signal received from ABS actuator and electric unit (control unit) with CAN communication line to the combination meter by means of communication line.
ABS actuator and electric unit (control unit)	Transmits the vehicle speed signal to the unified meter and A/C amp. with CAN communication line.

## TACHOMETER

### TACHOMETER : System Diagram

INFOID:000000004348046

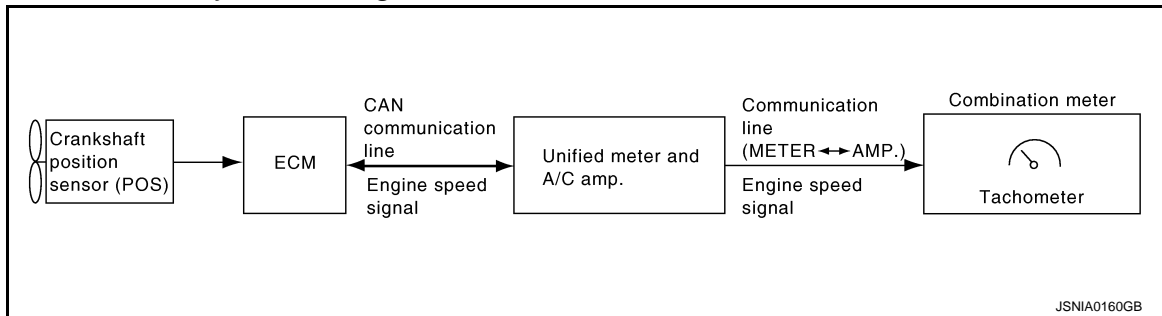

### TACHOMETER : System Description

INFOID:000000004348047

- ECM converts the pulse signal provided by the crankshaft position sensor to an engine speed signal and transmits it to the unified meter and A/C amp. with CAN communication line.
- The unified meter and A/C amp. receives the engine speed signal from ECM with CAN communication line and transmits it to the combination meter by means of communication line.
- Combination meter converses engine speed signal to the angle signal, and commands to tachometer.

# METER SYSTEM

< SYSTEM DESCRIPTION >

## TACHOMETER : Component Parts Location

INFOID:000000004923039

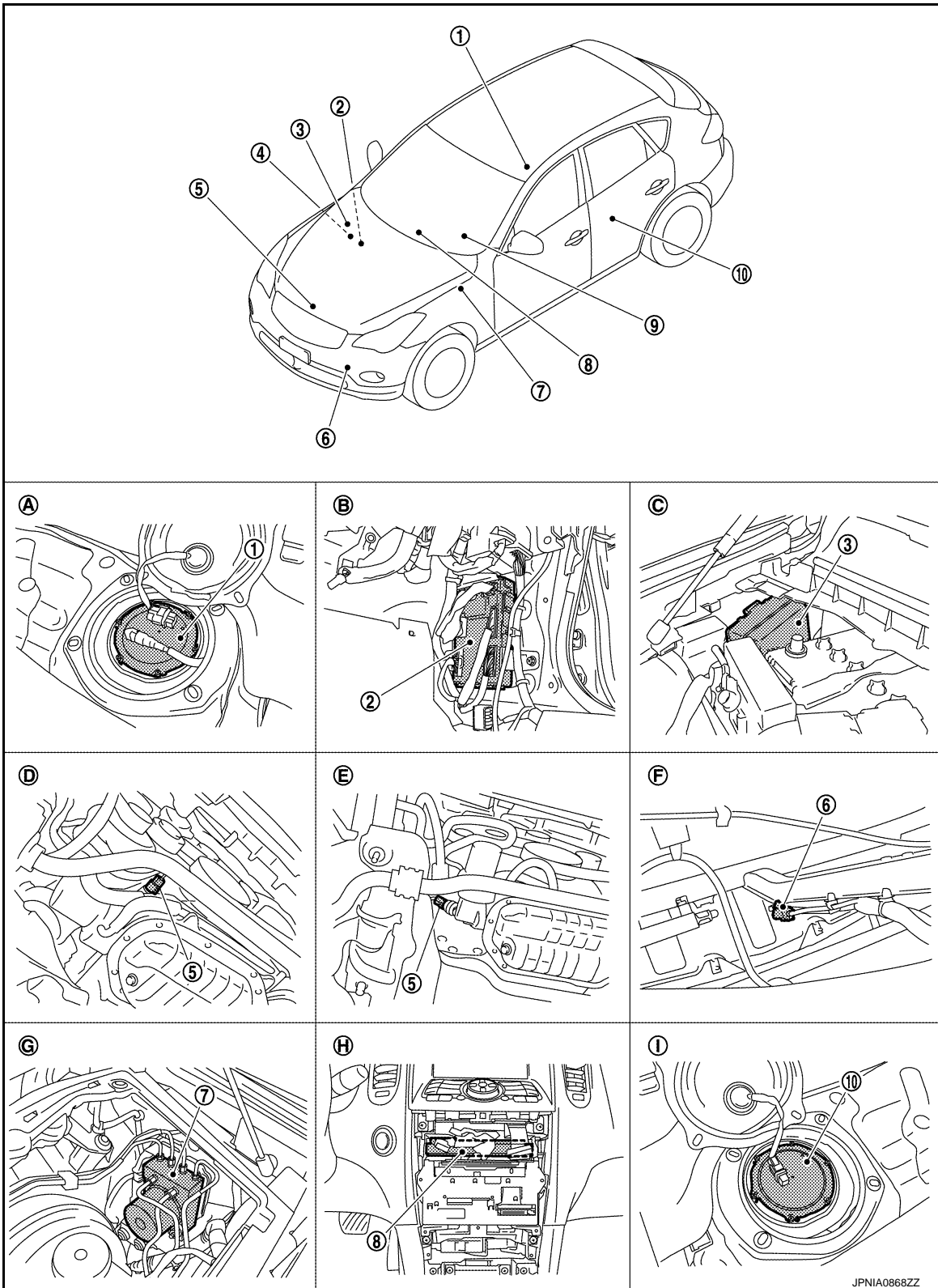

- |  |                        |                   |
|--|------------------------|-------------------|
| 1. Fuel level sensor unit and fuel pump (main)                         | 2. BCM                 | 3. IPDM E/R       |
| 4. ECM<br>Refer to <a href="#">EC-24. "Component Parts Location"</a> . | 5. Oil pressure switch | 6. Ambient sensor |

A  
B  
C  
D  
E  
F  
G  
H  
I  
J  
K  
L  
M  
N  
O  
P

MWI

JPNIA0868ZZ

# METER SYSTEM

## < SYSTEM DESCRIPTION >

- |  |  |                            |
|--|--|----------------------------|
| 7. ABS actuator and electric unit (control unit) | 8. Unified meter and A/C amp.          | 9. Combination meter       |
| 10. Fuel level sensor unit (sub)                 |  |                            |
| A. Rear seat (inside right)                      | B. Dash side finisher (passenger side) | C. Hoodledge cover (RH)    |
| D. 2WD [oil pan (upper) RH side]                 | E. AWD (oil filter bracket part)       | F. Condenser (front)       |
| G. Hoodledge cover (LH)                          | H. Behind cluster lid C                | I. Rear seat (inside left) |

## TACHOMETER : Component Description

INFOID:000000004348049

Unit	Description
Combination meter	Indicates the engine speed according to the engine speed signal received from the unified meter and A/C amp. by means of communication line.
Unified meter and A/C amp.	Transmits the engine speed signal received from ECM with CAN communication line to the combination meter by means of communication line.
ECM	Transmits the engine speed signal to the unified meter and A/C amp. with CAN communication line.

## ENGINE COOLANT TEMPERATURE GAUGE

### ENGINE COOLANT TEMPERATURE GAUGE : System Diagram

INFOID:000000004348050

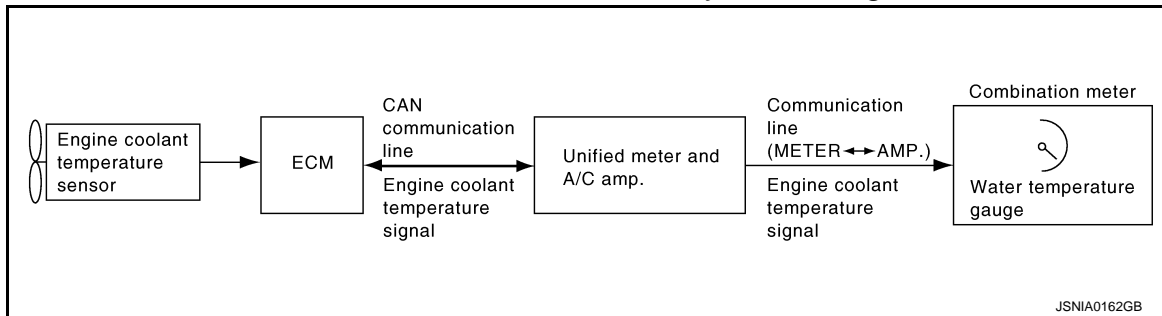

### ENGINE COOLANT TEMPERATURE GAUGE : System Description

INFOID:000000004348051

- ECM converts a signal from engine coolant temperature sensor to engine coolant temperature signal, and transmits to unified meter and A/C amp. with CAN communication line.
- Unified meter and A/C amp. transmits engine coolant temperature signal to combination meter with communication line.
- Combination meter converts engine coolant temperature signal to the angle signal, and commands to engine coolant temperature gauge.



# METER SYSTEM

< SYSTEM DESCRIPTION >

## ENGINE COOLANT TEMPERATURE GAUGE : Component Parts Location

INFOID:000000004923041

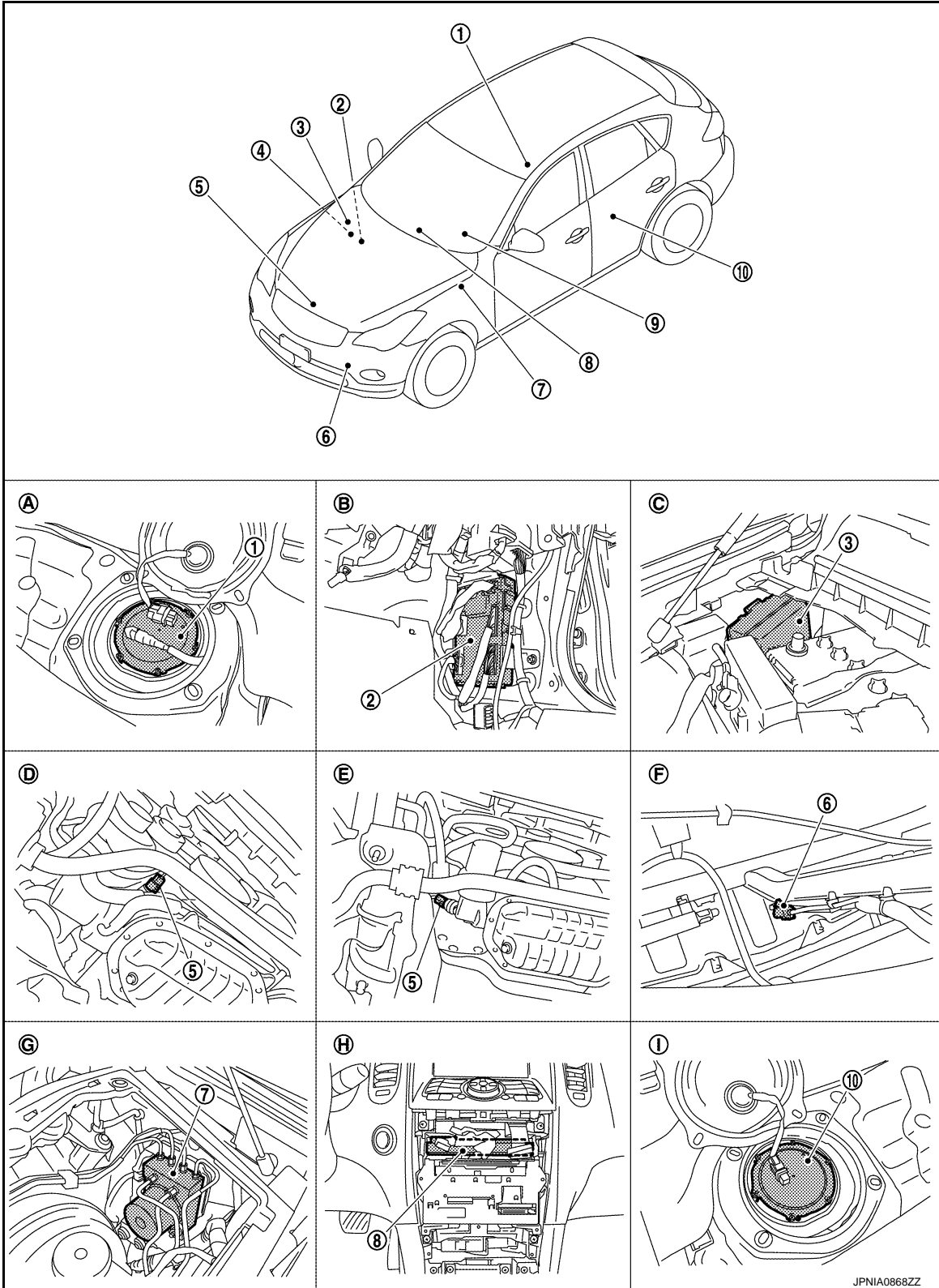

- |  |                        |                   |
|--|------------------------|-------------------|
| 1. Fuel level sensor unit and fuel pump (main)                         | 2. BCM                 | 3. IPDM E/R       |
| 4. ECM<br>Refer to <a href="#">EC-24. "Component Parts Location"</a> . | 5. Oil pressure switch | 6. Ambient sensor |

A  
B  
C  
D  
E  
F  
G  
H  
I  
J  
K  
L  
M  
N  
O  
P

MWI

JPNIA0868ZZ

# METER SYSTEM

## < SYSTEM DESCRIPTION >

- |  |  |                            |
|--|--|----------------------------|
| 7. ABS actuator and electric unit (control unit) | 8. Unified meter and A/C amp.          | 9. Combination meter       |
| 10. Fuel level sensor unit (sub)                 |  |                            |
| A. Rear seat (inside right)                      | B. Dash side finisher (passenger side) | C. Hoodledge cover (RH)    |
| D. 2WD [oil pan (upper) RH side]                 | E. AWD (oil filter bracket part)       | F. Condenser (front)       |
| G. Hoodledge cover (LH)                          | H. Behind cluster lid C                | I. Rear seat (inside left) |

## ENGINE COOLANT TEMPERATURE GAUGE : Component Description

INFOID:000000004348053

Unit	Description
Combination meter	Indicates the water temperature gauge according to the engine coolant temperature signal received from the unified meter and A/C amp. by means of communication line.
Unified meter and A/C amp.	Transmits the engine coolant temperature signal received from ECM with CAN communication line to the combination meter by means of communication line.
ECM	Transmits the engine coolant temperature signal to the unified meter and A/C amp. with CAN communication line.

## FUEL GAUGE

### FUEL GAUGE : System Diagram

INFOID:000000004348054

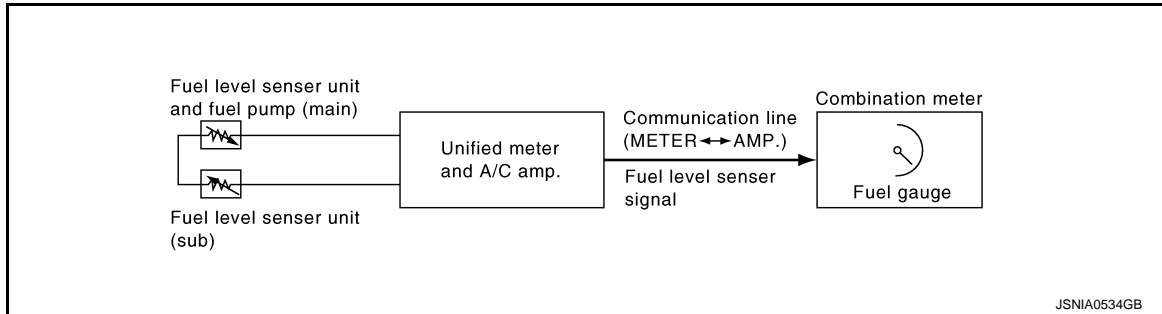

### FUEL GAUGE : System Description

INFOID:000000004348055

#### CONTROL OUTLINE

- The unified meter and A/C amp. reads the fuel level sensor signal from the fuel gauge unit and transmits it to the combination meter with the communication line.
- The combination meter indicates the fuel level on the fuel gauge according to the received fuel level sensor signal.

#### REFUEL CONTROL

The combination meter accelerates the fuel gauge segment if the all conditions listed below are met, or the ignition switch is ON from OFF.

- Ignition switch is ON position
- The vehicle is not moving
- The fuel level change by 15 ℓ (4 US gal, 3-3/10 Imp gal) or more

# METER SYSTEM

< SYSTEM DESCRIPTION >

## FUEL GAUGE : Component Parts Location

INFOID:000000004923042

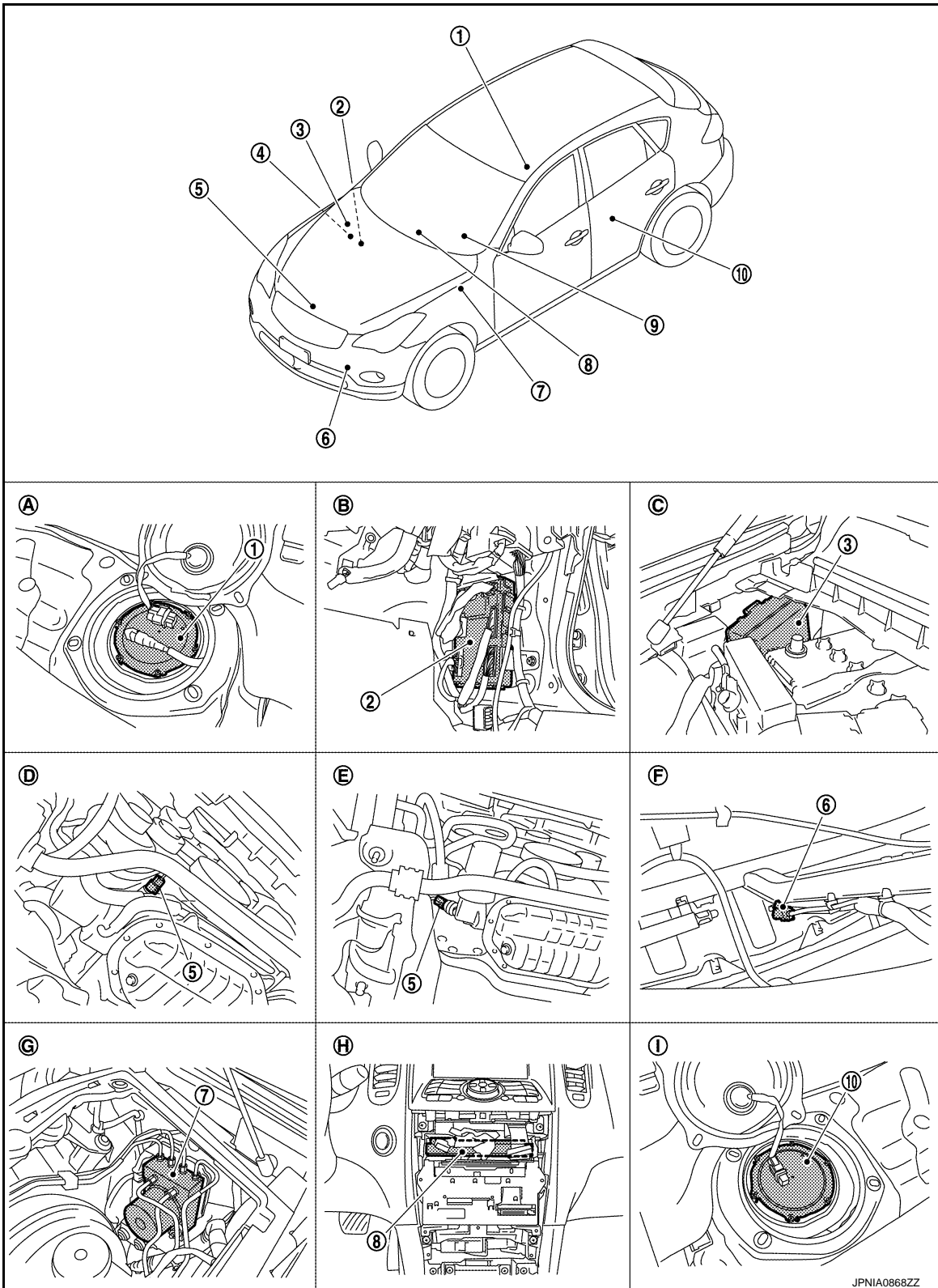

- |  |                        |                   |
|--|------------------------|-------------------|
| 1. Fuel level sensor unit and fuel pump (main)                         | 2. BCM                 | 3. IPDM E/R       |
| 4. ECM<br>Refer to <a href="#">EC-24. "Component Parts Location"</a> . | 5. Oil pressure switch | 6. Ambient sensor |

A  
B  
C  
D  
E  
F  
G  
H  
I  
J  
K  
L  
M  
N  
O  
P

MWI

JPNIA0868ZZ

# METER SYSTEM

## < SYSTEM DESCRIPTION >

- |  |  |                            |
|--|--|----------------------------|
| 7. ABS actuator and electric unit (control unit) | 8. Unified meter and A/C amp.          | 9. Combination meter       |
| 10. Fuel level sensor unit (sub)                 |  |                            |
| A. Rear seat (inside right)                      | B. Dash side finisher (passenger side) | C. Hoodledge cover (RH)    |
| D. 2WD [oil pan (upper) RH side]                 | E. AWD (oil filter bracket part)       | F. Condenser (front)       |
| G. Hoodledge cover (LH)                          | H. Behind cluster lid C                | I. Rear seat (inside left) |

## FUEL GAUGE : Component Description

INFOID:000000004348057

Unit	Description
Combination meter	Indicates the fuel gauge according to the fuel level sensor signal received from the unified meter and A/C amp. by means of communication line.
Unified meter and A/C amp.	Transmits the fuel level sensor signal from the fuel level sensor unit to the combination meter by means of communication line.
Fuel level sensor unit	Refer to <a href="#">MWI-56, "Description"</a> .

## ODO/TRIP METER

### ODO/TRIP METER : System Diagram

INFOID:000000004348058

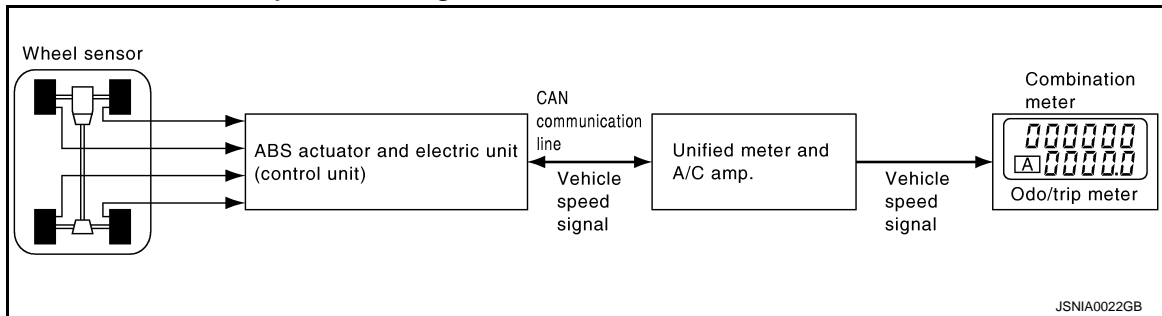

### ODO/TRIP METER : System Description

INFOID:000000004348059

- The unified meter and A/C amp. transmits the vehicle speed signal from ABS actuator and electric unit (control unit) to the combination meter.
- The combination meter calculates the vehicle distance according to the vehicle speed signal. The vehicle distance is displayed.

# METER SYSTEM

< SYSTEM DESCRIPTION >

## ODO/TRIP METER : Component Parts Location

INFOID:000000004923045

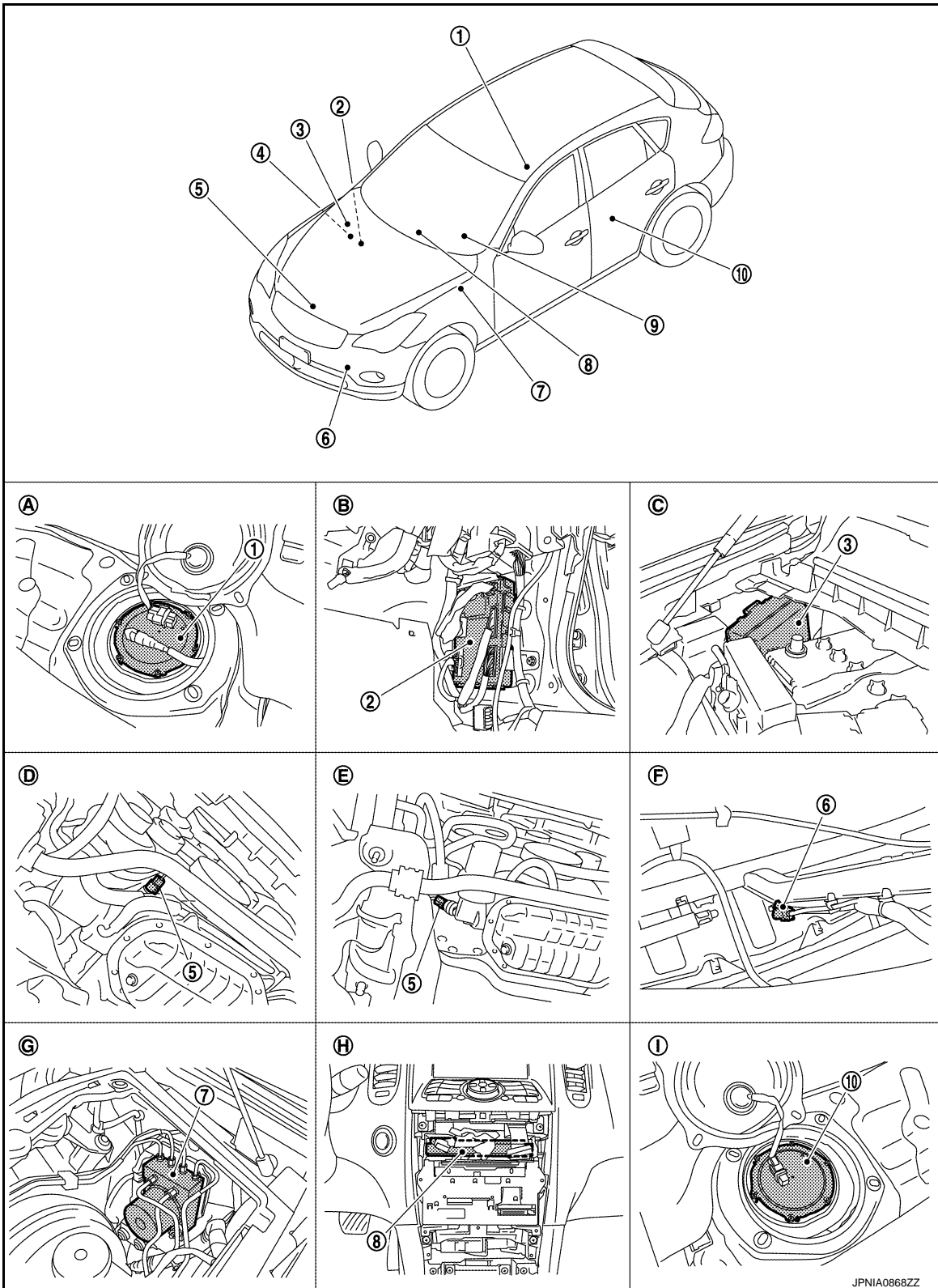

- |  |                        |                   |
|--|------------------------|-------------------|
| 1. Fuel level sensor unit and fuel pump (main)                         | 2. BCM                 | 3. IPDM E/R       |
| 4. ECM<br>Refer to <a href="#">EC-24. "Component Parts Location"</a> . | 5. Oil pressure switch | 6. Ambient sensor |

A  
B  
C  
D  
E  
F  
G  
H  
I  
J  
K  
L  
M  
N  
O  
P

MWI

JPNIA0868ZZ

# METER SYSTEM

## < SYSTEM DESCRIPTION >

- |  |  |                            |
|--|--|----------------------------|
| 7. ABS actuator and electric unit (control unit) | 8. Unified meter and A/C amp.          | 9. Combination meter       |
| 10. Fuel level sensor unit (sub)                 |  |                            |
| A. Rear seat (inside right)                      | B. Dash side finisher (passenger side) | C. Hoodledge cover (RH)    |
| D. 2WD [oil pan (upper) RH side]                 | E. AWD (oil filter bracket part)       | F. Condenser (front)       |
| G. Hoodledge cover (LH)                          | H. Behind cluster lid C                | I. Rear seat (inside left) |

## ODO/TRIP METER : Component Description

INFOID:000000004348061

Unit	Description
Combination meter	The combination meter calculates the vehicle distance according to the vehicle speed signal. The vehicle distance is displayed.
Unified meter and A/C amp.	The unified meter and A/C amp. transmits the vehicle speed signal from ABS actuator and electric unit (control unit) to the combination meter.
ABS actuator and electric unit (control unit)	Transmits the vehicle speed signal to the unified meter and A/C amp. with CAN communication line.

## SHIFT POSITION INDICATOR

### SHIFT POSITION INDICATOR : System Diagram

INFOID:000000004348062

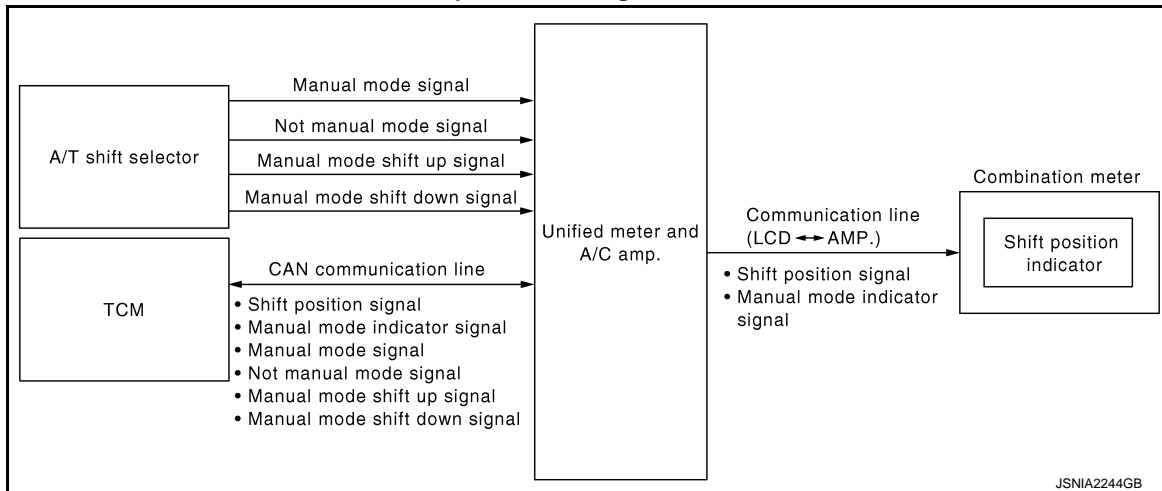

### SHIFT POSITION INDICATOR : System Description

INFOID:000000004348063

Shift position is displayed in the information display LCD in the combination meter.

#### MANUAL MODE

- Unified meter and A/C amp. inputs manual mode signal and shift-up/down signal from A/T shift selector (manual mode switch), and transmits the signals to TCM with CAN communication line.
- TCM processes manual mode signal and shift-up/down signal, and transmits manual mode indicator signal and shift position signal to unified meter and A/C amp. with CAN communication line.
- Unified meter and A/C amp. transmits manual mode indicator signal and shift position signal to combination meter with the communication line.
- Combination meter indicates A/T gear position and manual mode indicator, when receiving manual mode indicator signal and shift position signal.

#### NOT MANUAL MODE

- Unified meter and A/C amp. inputs not manual mode signal from A/T shift selector (manual mode switch), and transmits the signals to TCM with CAN communication line.
- TCM transmits shift position signal to unified meter and A/C amp. with CAN communication line.
- Unified meter and A/C amp. transmits shift position signal to combination meter with the communication line.
- Combination meter indicates A/T shift position when receiving shift position signal.

# METER SYSTEM

< SYSTEM DESCRIPTION >

## SHIFT POSITION INDICATOR : Component Parts Location

INFOID:000000004923047

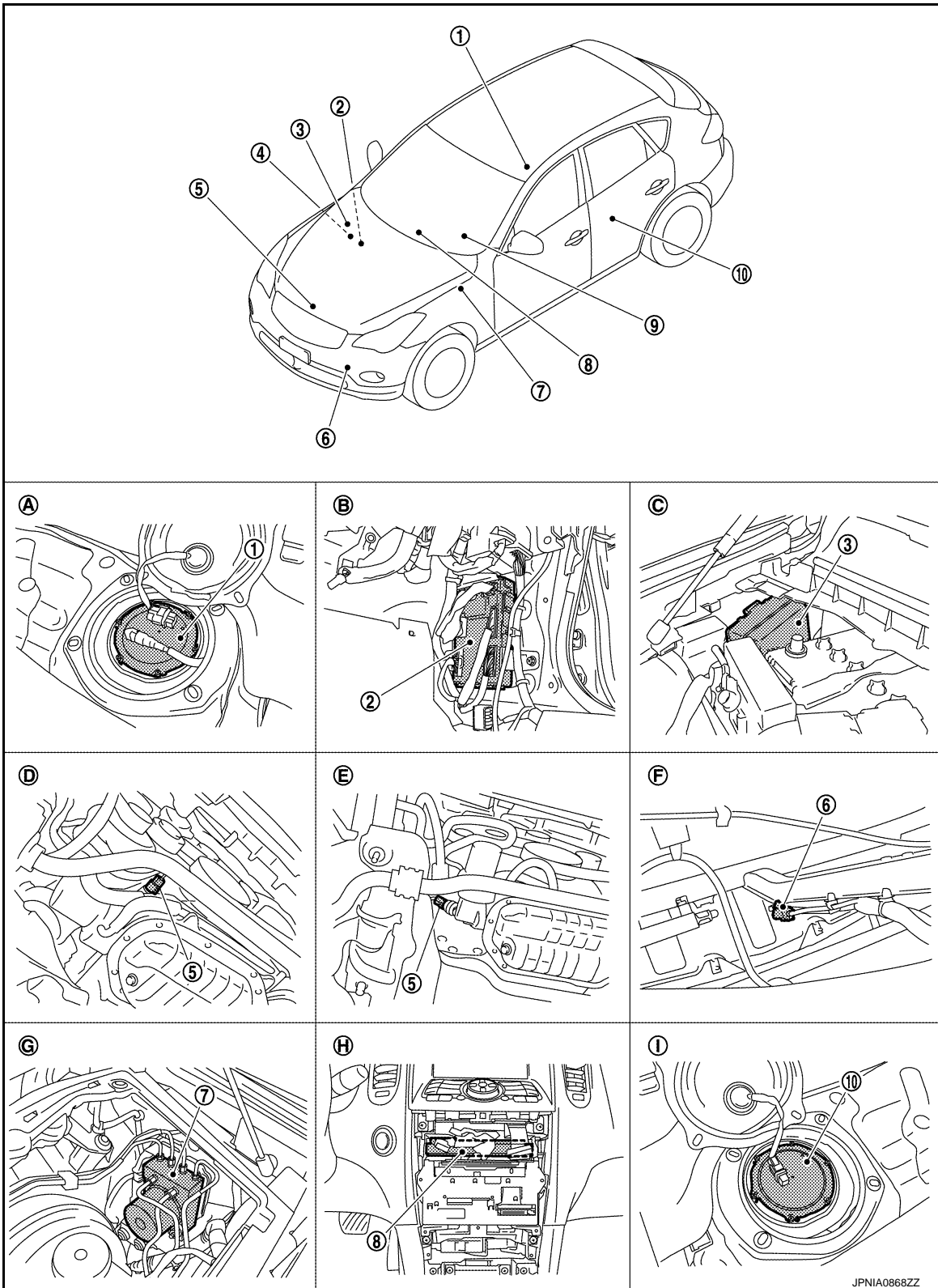

- |  |                        |                   |
|--|------------------------|-------------------|
| 1. Fuel level sensor unit and fuel pump (main)                         | 2. BCM                 | 3. IPDM E/R       |
| 4. ECM<br>Refer to <a href="#">EC-24. "Component Parts Location"</a> . | 5. Oil pressure switch | 6. Ambient sensor |

A  
B  
C  
D  
E  
F  
G  
H  
I  
J  
K  
L  
M  
N  
O  
P

MWI

JPNIA0868ZZ

# METER SYSTEM

## < SYSTEM DESCRIPTION >

- |  |  |                            |
|--|--|----------------------------|
| 7. ABS actuator and electric unit (control unit) | 8. Unified meter and A/C amp.          | 9. Combination meter       |
| 10. Fuel level sensor unit (sub)                 |  |                            |
| A. Rear seat (inside right)                      | B. Dash side finisher (passenger side) | C. Hoodledge cover (RH)    |
| D. 2WD [oil pan (upper) RH side]                 | E. AWD (oil filter bracket part)       | F. Condenser (front)       |
| G. Hoodledge cover (LH)                          | H. Behind cluster lid C                | I. Rear seat (inside left) |

## SHIFT POSITION INDICATOR : Component Description

INFOID:000000004348065

Unit	Description
Combination meter	Displays the shift position on the information display with shift position signal and manual mode indicator signal received from unified meter and A/C amp.
Unified meter and A/C amp.	<ul style="list-style-type: none"> <li>Transmits the signals from the A/T shift selector to TCM with CAN communication line.</li> <li>Transmits shift position signal and manual mode indicator signal received from TCM with CAN communication line to the combination meter by means of communication line.</li> </ul>
A/T shift selector	Transmits the following signals to the unified meter and A/C amp. <ul style="list-style-type: none"> <li>Manual mode signal</li> <li>Manual mode shift up signal</li> <li>Not manual mode signal</li> <li>Manual mode shift down signal</li> </ul>
TCM	Transmits shift position signal and manual mode indicator signal to the unified meter and A/C amp.

## WARNING LAMPS/INDICATOR LAMPS

### WARNING LAMPS/INDICATOR LAMPS : System Diagram

INFOID:000000004348066

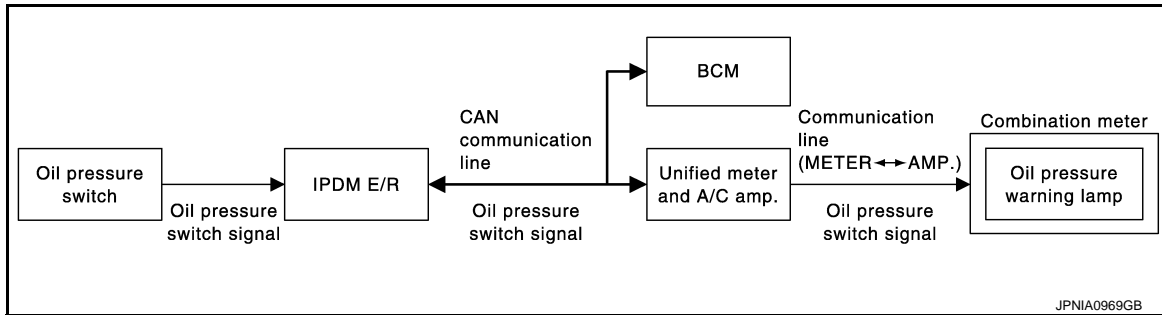

### WARNING LAMPS/INDICATOR LAMPS : System Description

INFOID:000000004348067

#### OIL PRESSURE WARNING LAMP

- IPDM E/R inputs oil pressure switch signal from oil pressure switch, and transmits the signal to unified meter and A/C amp. through BCM with CAN communication line.
- Unified meter and A/C amp. transmits oil pressure switch signal to combination meter with communication line.
- Let the combination meter turn oil pressure warning lamp ON with received oil pressure switch signal.



# METER SYSTEM

< SYSTEM DESCRIPTION >

## WARNING LAMPS/INDICATOR LAMPS : Component Parts Location

INFOID:000000004923051

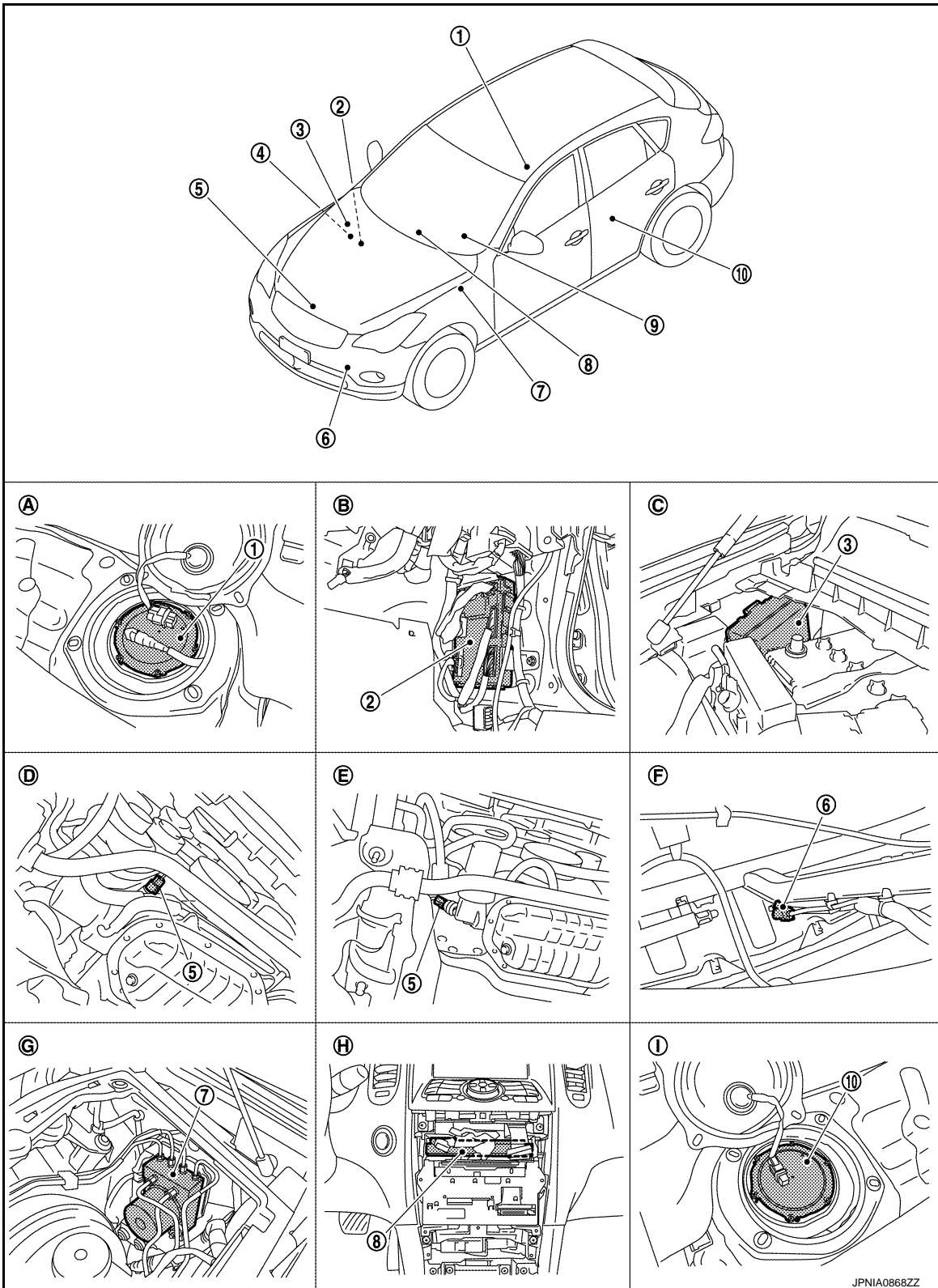

- |  |                        |                   |
|--|------------------------|-------------------|
| 1. Fuel level sensor unit and fuel pump (main)                         | 2. BCM                 | 3. IPDM E/R       |
| 4. ECM<br>Refer to <a href="#">EC-24. "Component Parts Location"</a> . | 5. Oil pressure switch | 6. Ambient sensor |

A  
B  
C  
D  
E  
F  
G  
H  
I  
J  
K  
L  
M  
N  
O  
P

MWI

JPNIA0868ZZ

# METER SYSTEM

## < SYSTEM DESCRIPTION >

- |  |  |                            |
|--|--|----------------------------|
| 7. ABS actuator and electric unit (control unit) | 8. Unified meter and A/C amp.          | 9. Combination meter       |
| 10. Fuel level sensor unit (sub)                 |  |                            |
| A. Rear seat (inside right)                      | B. Dash side finisher (passenger side) | C. Hoodledge cover (RH)    |
| D. 2WD [oil pan (upper) RH side]                 | E. AWD (oil filter bracket part)       | F. Condenser (front)       |
| G. Hoodledge cover (LH)                          | H. Behind cluster lid C                | I. Rear seat (inside left) |

## WARNING LAMPS/INDICATOR LAMPS : Component Description

INFOID:000000004348069

Unit	Description
Combination meter	Turns the oil pressure warning lamp ON/OFF according to the oil pressure switch signal received from the unified meter and A/C amp. by means of communication line.
Unified meter and A/C amp.	Transmits the oil pressure switch signal received from the IPDM E/R with BCM to the combination meter by means of communication line.
IPDM E/R	IPDM E/R reads the ON/OFF signals from the oil pressure switch and transmits the oil pressure switch signal to the unified meter and A/C amp. via BCM with the CAN communication line.
Oil pressure switch	Refer to <a href="#">MWI-63, "Description"</a> .
BCM	Transmits the oil pressure switch signal received from IPDM E/R via CAN communication to the unified meter and A/C amp. via CAN communication line.

## METER ILLUMINATION CONTROL

### METER ILLUMINATION CONTROL : System Diagram

INFOID:000000004348070

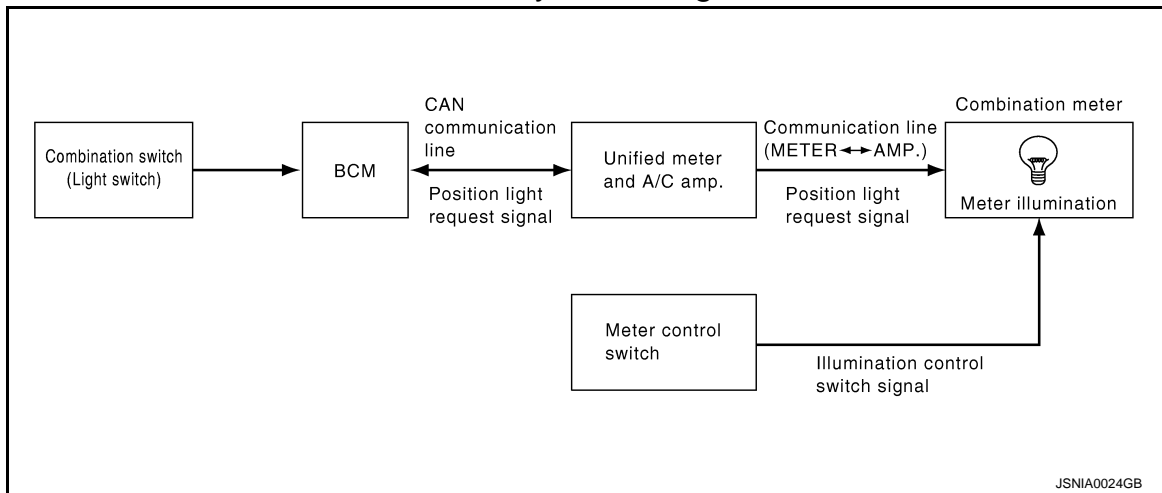

### METER ILLUMINATION CONTROL : System Description

INFOID:000000004348071

#### SYSTEM DESCRIPTION

The combination meter controls the meter illumination by the illumination control switch signal from the meter control switch and the position light request signal transmitted by BCM with unified meter and A/C amp.

Daytime Mode

# METER SYSTEM

## < SYSTEM DESCRIPTION >

Meter illumination is adjusted to 5 steps by illumination control switch (1) in daytime mode.

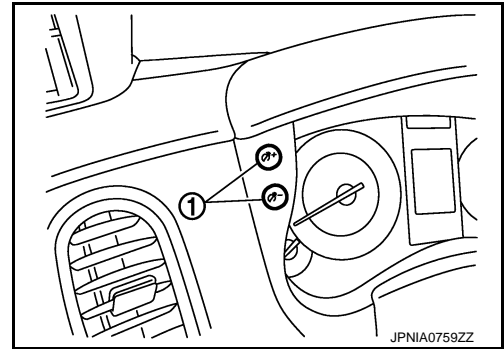

### Nighttime Mode

- Combination meter is transferred to nighttime mode with position light request signal from BCM with CAN communication line.
- Meter illumination is adjusted to 22 steps by illumination control switch in nighttime.

A  
B  
C  
D  
E  
F  
G  
H  
I  
J  
K  
L  
M  
O  
P

MWI

# METER SYSTEM

< SYSTEM DESCRIPTION >

## METER ILLUMINATION CONTROL : Component Parts Location

INFOID:000000004923054

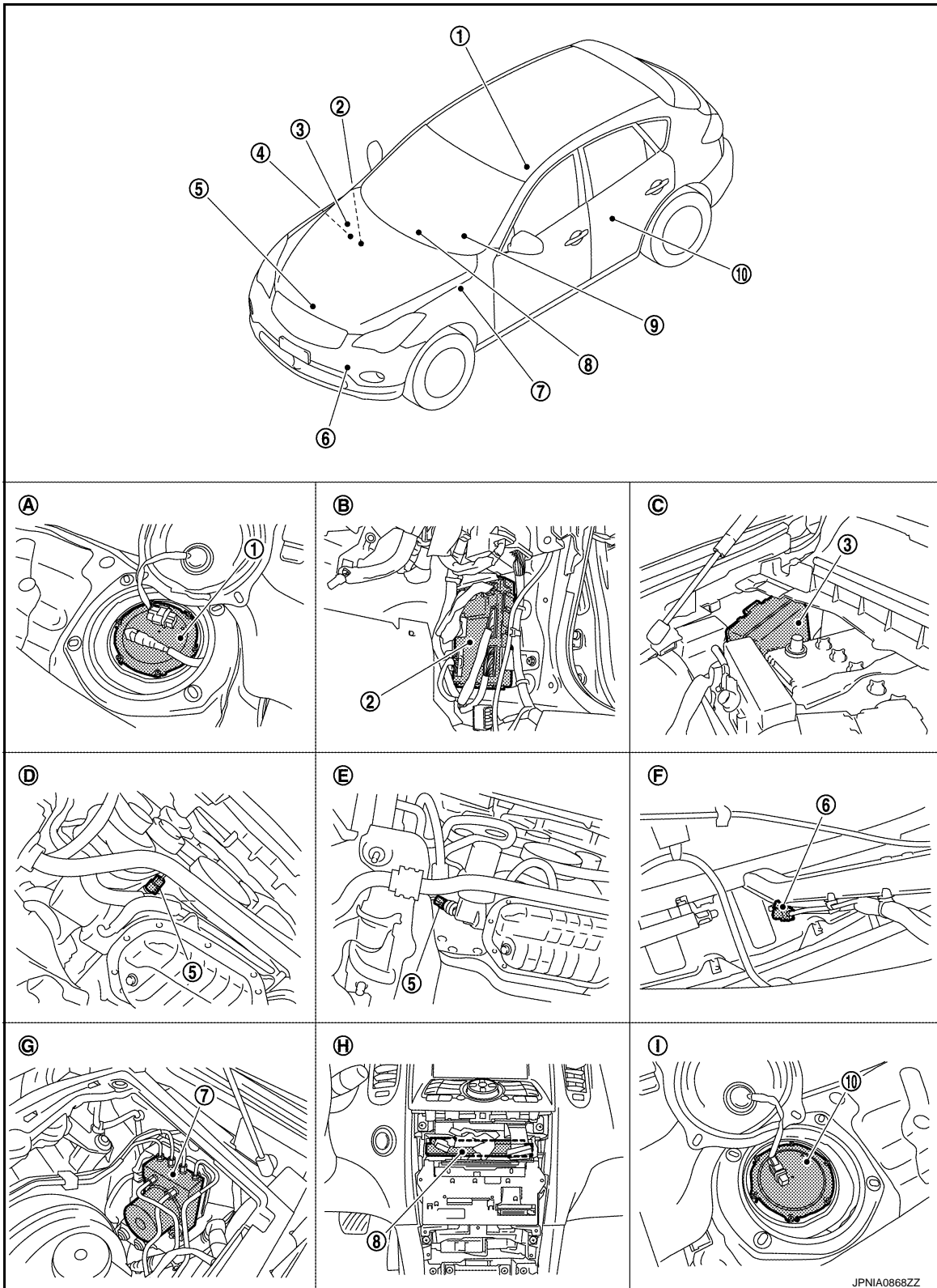

- |  |                        |                   |
|--|------------------------|-------------------|
| 1. Fuel level sensor unit and fuel pump (main) | 2. BCM                 | 3. IPDM E/R       |
| 4. ECM   | 5. Oil pressure switch | 6. Ambient sensor |
- Refer to [EC-24. "Component Parts Location"](#).

JPNIA0868ZZ

# METER SYSTEM

## < SYSTEM DESCRIPTION >

- |  |  |                            |
|--|--|----------------------------|
| 7. ABS actuator and electric unit (control unit) | 8. Unified meter and A/C amp.          | 9. Combination meter       |
| 10. Fuel level sensor unit (sub)                 |  |                            |
| A. Rear seat (inside right)                      | B. Dash side finisher (passenger side) | C. Hoodledge cover (RH)    |
| D. 2WD [oil pan (upper) RH side]                 | E. AWD (oil filter bracket part)       | F. Condenser (front)       |
| G. Hoodledge cover (LH)                          | H. Behind cluster lid C                | I. Rear seat (inside left) |

## METER ILLUMINATION CONTROL : Component Description

INFOID:000000004348073

Unit	Description
Combination meter	Controls the meter illumination with the illumination control switch signal from the meter control switch and the position light request signal from unified meter and A/C amp.
Unified meter and A/C amp.	Transmits the position light request signal received from BCM via CAN communication to the combination meter by means of communication.
Meter control switch	Transmits the following signals to the combination meter. <ul style="list-style-type: none"> <li>• Illumination control switch signal (+)</li> <li>• Illumination control switch signal (-)</li> </ul>

## INFORMATION DISPLAY

### INFORMATION DISPLAY : System Diagram

INFOID:000000004348074

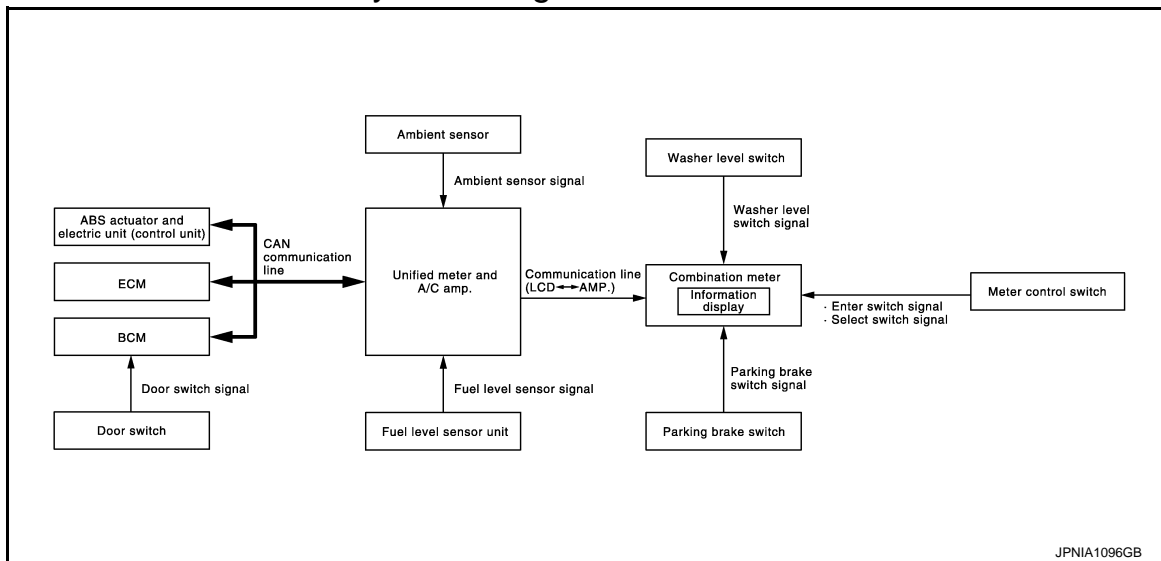

### INFORMATION DISPLAY : System Description

INFOID:000000004348075

#### DESCRIPTION

- The combination meter retrieves the information required for controlling the operations of the information display from the communication signals from the unified meter and A/C amp., etc.
- The combination meter incorporates a trip computer that displays the warning / information according to the information received from various units.

#### PARKING BRAKE RELEASE WARNING

The combination meter indicates parking brake release warning judged with the vehicle speed signal received from the unified meter and A/C amp. by means of communication line and the parking brake switch signal from the parking brake switch.

#### Warning Operation Condition

Parking brake release warning is judged if all of the following conditions are fulfilled

- Vehicle speed is 7 km/h (4.3 MPH) or higher
- Parking brake switch ON

#### LOW FUEL WARNING

# METER SYSTEM

## < SYSTEM DESCRIPTION >

The combination meter indicates low fuel warning judged with the fuel level sensor signal received from the unified meter and A/C amp.

Warning Operation Condition

- Fuel level: Approx. 12 ℓ (3-1/8 US gal, 2-5/8 Imp gal) or less

### LOW WASHER FLUID WARNING

The combination meter indicates low washer fluid warning judged with the signal from the washer level switch.

Warning Operation Condition

- Indicates the warning when it is in washer level switch ON condition for 180 seconds or more. Release the warning when it is in washer level switch OFF condition for 30 seconds or more.

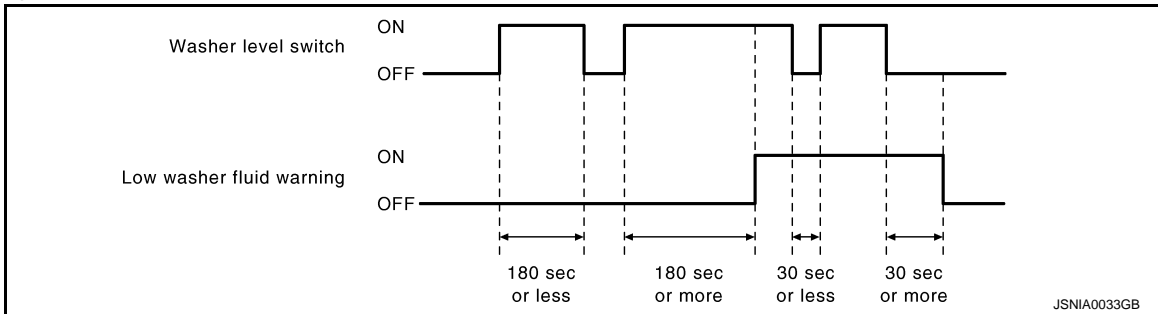

### DOOR OPEN WARNING

The combination meter indicates door open warning judged with each door switch signal received from the unified meter and A/C amp. by means of communication line.

### INSTANTANEOUS FUEL CONSUMPTION

- The unified meter and A/C amp. receives the fuel consumption monitor signal from ECM and the vehicle speed signal from the ABS actuator and electric unit (control unit) with CAN communication line.
- The unified meter and A/C amp. calculates the instantaneous fuel consumption according to the fuel consumption monitor signal and the vehicle speed signal received with CAN communication line, and transmits it to the combination meter.

### AVERAGE FUEL CONSUMPTION

- The unified meter and A/C amp. receives the fuel consumption monitor signal from ECM and the vehicle speed signal from the ABS actuator and electric unit (control unit) with CAN communication line.
- The unified meter and A/C amp. calculates the average fuel consumption according to the fuel consumption monitor signal and the vehicle speed signal received with CAN communication line, and transmits it to the combination meter.
- The average fuel consumption displayed on the information display is uploaded at approximately 30-second intervals.

#### NOTE:

When turning ON the ignition switch after triggering a reset or removing/installing the battery, “——” is indicated until 30 seconds/500 m (0.31 miles) of driving.

### AVERAGE VEHICLE SPEED

- The unified meter and A/C amp. receives the vehicle speed signal from the ABS actuator and electric unit (control unit) via CAN communication line.
- Measures the time during the ignition switch ON with the unified meter and A/C amp.
- The unified meter and A/C amp. calculates the average vehicle speed according to the above signals. These signals are transmitted to the combination meter with the communication line.
- The average vehicle speed displayed on the information display is uploaded at approximately 30-second intervals.

#### NOTE:

When turning ON the ignition switch after triggering a reset or removing/installing the battery, “——” is indicated until 30 seconds/500 m (0.31 miles) of driving.

### TRAVEL TIME

Measures the time during the ignition switch ON with the unified meter and A/C amp, and transmits it to the combination meter by means of communication line.

### TRAVEL DISTANCE

# METER SYSTEM

## < SYSTEM DESCRIPTION >

- The unified meter and A/C amp. transmits the vehicle speed signal from ABS actuator and electric unit (control unit) to the combination meter.
- The combination meter calculates the vehicle distance according to the vehicle speed signal. The vehicle distance is displayed.

## POSSIBLE DRIVING DISTANCE

The unified meter and A/C amp. calculates possible driving distance according to the vehicle speed signal and fuel consumption monitor signal transmitted via CAN communication and the fuel level sensor signal transmitted from the fuel level sensor. These signals are transmitted to the combination meter with the communication line.

### NOTE:

- When turning ON the ignition switch after removing/installing the battery, “—” is indicated until 30 seconds.
- “—” is displayed for 30 seconds after the ignition switch is OFF → ON. It is displayed simultaneously until the vehicle drives approximately 500 m (0.31 mile).
- The indicated values may not match each other when filling the fuel with the ignition switch ON. Refer to [MWI-123. "INFORMATION DISPLAY : Description"](#).

## AMBIENT AIR TEMPERATURE

- The unified meter and A/C amp. receives the ambient sensor signal from the ambient sensor.
- The unified meter and A/C amp. calculates the ambient temperature according to the ambient sensor signal, and transmits it to the combination meter.
- The indicated temperature does not increase if the vehicle speed is less than 20 km/h (12 MPH).

### NOTE:

- The ambient sensor input value that is displayed on “Data Monitor” of CONSULT-III is the value before the correction. It may not match the indicated temperature on the information display.
- Ambient temperature may be indicated higher than an actual temperature, depending on heat in the engine, a road surface temperature, and so on.

## SETTING

### Setting item list

Items		Setting range	Setting unit	Description
ALERT	TIME TO REST	No setting - 6 hours	30 minutes, [60 minutes]*	Time to rest is displayed on the information display if the vehicle reached the set travel distance.
	ICY	ON/OFF	—	Low outside temp is displayed on the information display if the ambient temperature is 3°C (37°F) or less.
MAINTENANCE	ENGINE OIL	No setting - 18,500 miles, (No setting - 30,000 km)	250 miles (500 km), [500 miles (1000 km)]*	The engine oil replacement interval is displayed on the information display if the vehicle reached the set distance.
	OIL FILTER	No setting - 18,500 miles, (No setting - 30,000 km)	250 miles (500 km), [500 miles (1000 km)]*	The oil filter replacement interval is displayed on the information display if the vehicle reached the set distance.
	TIRE	No setting - 18,500 miles, (No setting - 30,000 km)	250 miles (500 km), [500 miles (1000 km)]*	The tire replacement interval is displayed on the information display if the vehicle reached the set distance.
	OTHER	No setting - 18,500 miles, (No setting - 30,000 km)	250 miles (500 km), [500 miles (1000 km)]*	The other replacement interval is displayed on the information display if the vehicle reached the set distance.
DISPLAY	LANGUAGE	ENGLISH/FRANCAIS	—	Changing the language setting can be performed.
	UNIT	US/METRIC	—	Changing the unit setting can be performed.

\*: Press and hold the switch (1 second or more).

# METER SYSTEM

< SYSTEM DESCRIPTION >

## INFORMATION DISPLAY : Component Parts Location

INFOID:000000004923060

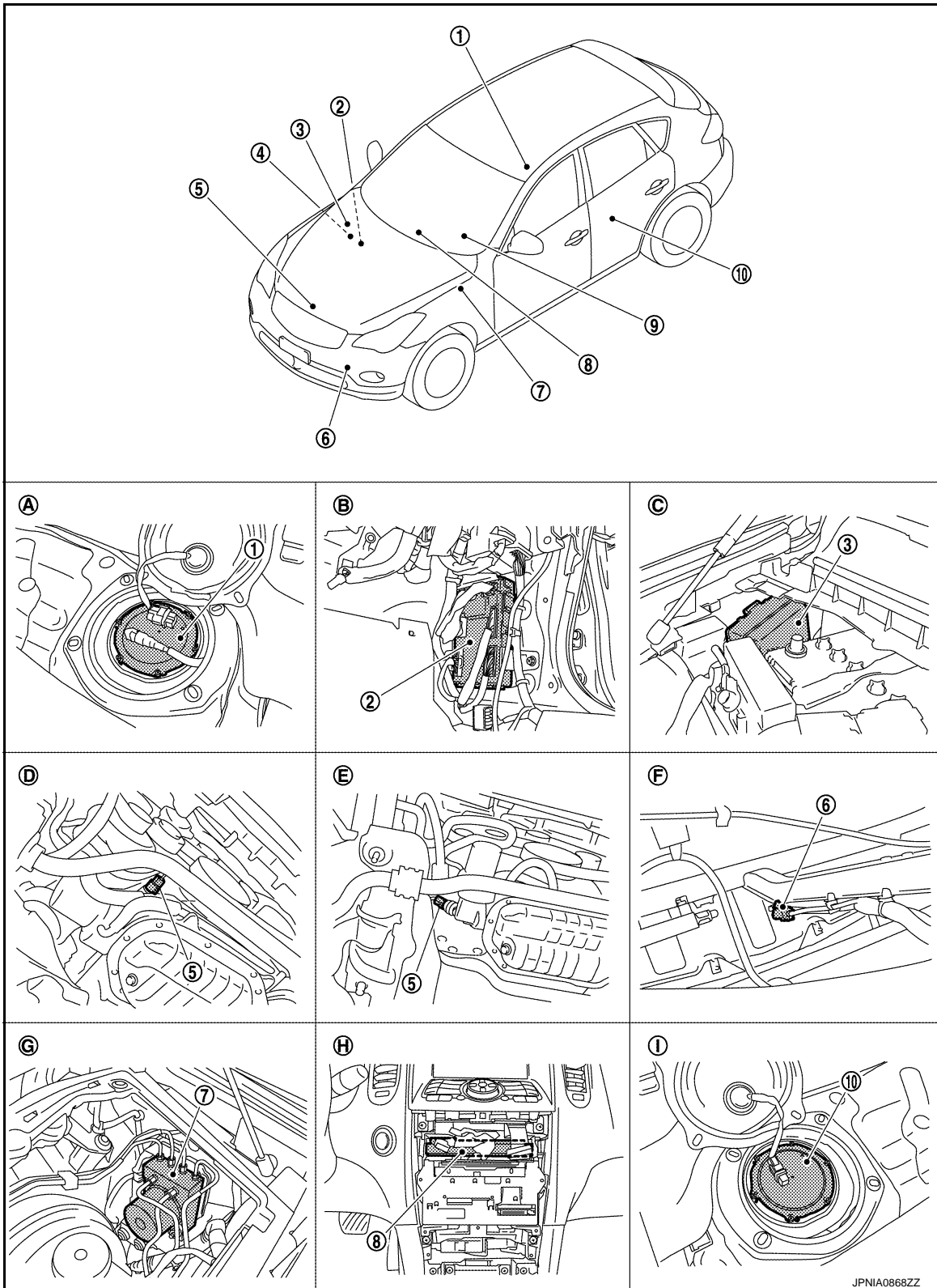

- |  |                        |                   |
|--|------------------------|-------------------|
| 1. Fuel level sensor unit and fuel pump (main) | 2. BCM                 | 3. IPDM E/R       |
| 4. ECM   | 5. Oil pressure switch | 6. Ambient sensor |
- Refer to [EC-24. "Component Parts Location"](#).



# METER SYSTEM

## < SYSTEM DESCRIPTION >

- |  |  |                            |
|--|--|----------------------------|
| 7. ABS actuator and electric unit (control unit) | 8. Unified meter and A/C amp.          | 9. Combination meter       |
| 10. Fuel level sensor unit (sub)                 |  |                            |
| A. Rear seat (inside right)                      | B. Dash side finisher (passenger side) | C. Hoodledge cover (RH)    |
| D. 2WD [oil pan (upper) RH side]                 | E. AWD (oil filter bracket part)       | F. Condenser (front)       |
| G. Hoodledge cover (LH)                          | H. Behind cluster lid C                | I. Rear seat (inside left) |

## INFORMATION DISPLAY : Component Description

INFOID:000000004348077

Unit	Description
Combination meter	Controls the information display with the signals received from the unified meter and A/C amp. by means of communication and the signals from various switches and sensors.
Unified meter and A/C amp.	Transmits signals received from various units to the combination meter by means of communication.
Fuel level sensor unit	Refer to <a href="#">MWI-56, "Description"</a> .
ECM	Transmits the following signals to the unified meter and A/C amp. via CAN communication. <ul style="list-style-type: none"> <li>• Engine speed signal</li> <li>• Fuel consumption monitor signal</li> </ul>
ABS actuator and electric unit (control unit)	Transmits the vehicle speed signal to the unified meter and A/C amp. via CAN communication.
BCM	Transmits signals provided by various units to the unified meter and A/C amp. via CAN communication.
Meter control switch	Transmits the following signals to the combination meter. <ul style="list-style-type: none"> <li>• Enter switch signal</li> <li>• Select switch signal</li> </ul>
Washer level switch	Transmits the washer level signal to the combination meter.
Parking brake switch	Refer to <a href="#">MWI-64, "Description"</a> .
Door switch	Transmits the door switch signals to BCM.
Ambient sensor	Detects the ambient air temperature and transmits the ambient sensor signal to the unified meter and A/C amp.

A  
B  
C  
D  
E  
F  
G  
H  
I  
J  
K  
L  
M  
N  
O  
P

MWI

# COMPASS

< SYSTEM DESCRIPTION >

## COMPASS

### Description

INFOID:000000004348078

### DESCRIPTION

- This electronic compass is able to display 8 primary directions: N, NE, E, SE, S, SW, W, NW.
- The compass switch (1) is used to operate the compass.

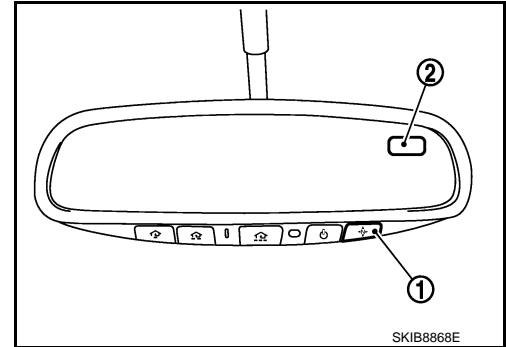

#### Switch Operation

Press	Compass is turned ON/OFF
Press and hold (for 3- 9 sec.)	Compass display (2) turns to zone variation change mode
Press and hold (for more than 9 sec.)	Compass display turns to calibration mode

- All standard compasses determine direction relative to magnetic north; however, this electronic compass is designed to display direction relative to true north.
- The difference between magnetic north and true north varies from place to place across the surface of the earth.
- This electronic compass must be “told” approximately where it is on the earth’s surface so that the magnetic north reading can be properly converted into a true north display.
- To tell the electronic compass where it’s at, the earth is separated into numbered “Zone Variances”. The zone variance number in which the compass is to function must be entered into this electronic compass.
- Each zone is magnetically about 4.2° wide. Typically, anything under 22.5° total zone change is not noticed on the electronic compass display. However, over 22.5°, a reading may be off by one or more primary directions.
- On long trips, a vehicle may leave its original zone and enter one or more new zones. Generally, you do not need to reset the compass zone if you travel between 3 or 4 zones, such as business travel or vacation. The typical driver will not notice any difference on the display within 3 or 4 zones. However, if the vehicle is “permanently” moved to a new location, it is recommended that the compass zone be reset.

### ZONE VARIATION SETTING PROCEDURE

# COMPASS

## < SYSTEM DESCRIPTION >

1. Press and hold the compass switch for 3 – 9 seconds.
2. The current zone setting appears on the compass display.
3. Find the current geographical location number in the zone variation chart.
4. Select the new zone number. (Press the compass switch until the new zone number appears on the compass display.)
5. After select the new zone number, the compass display will automatically shows a direction within a few seconds.
6. Perform the following calibration procedure for more accurate indications.

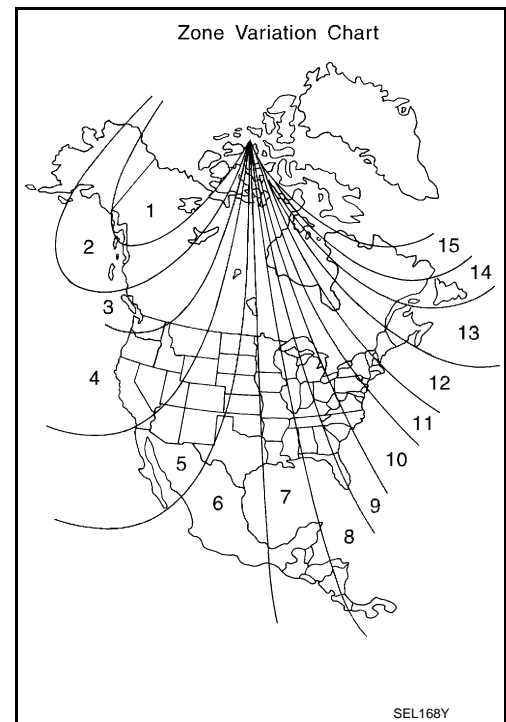

## CALIBRATION PROCEDURE

### NOTE:

The compass calibrates itself under normal driving conditions. However, occasional circumstances may cause the compass to operate inaccurately. Example: Driving from rural (wide open) areas to crowded city areas, or if an aftermarket (i.e., non original equipment) antenna with a magnetic base is attached to the vehicle. Calibrate the mirror compass if the display shows only one direction or a limited number of directions.

### NOTE:

- If “magnetic hats” are used in the dealership for vehicle identification, remove the hat from the vehicle before performing the following steps. Do not put the hat back on the vehicle after the procedure is completed.
  - Drive the vehicle to an open level area; away from large metallic objects, structures, and overhead power lines.
  - Turn off “non-essential” electrical accessories (rear window defrost, heater/air conditioning, wipers) and close the doors.
1. Verify the correct compass zone setting for the geographical location.
  2. Press and hold the compass switch for more than 9 seconds.
  3. “C” is displayed on the compass display, when calibration starts.
  4. Drive slowly [less than 8 km/h (5 MPH)] in a circle until the “C / CAL” is replaced with primary headings (N, NE, E, SE, S, SW, W, or NW).

### NOTE:

This will require driving at least 2 complete 360 degree circles; 3 complete circles may be required.

5. The compass calibration procedure is now complete. The compass should operate normally.

### NOTE:

If at any time the compass continually displays the incorrect direction or the reading is erratic or locked, repeat the calibration procedure.

A  
B  
C  
D  
E  
F  
G  
H  
I  
J  
K  
L  
M  
O  
P

MWI

# COMPASS

< SYSTEM DESCRIPTION >

## Component Parts Location

INFOID:000000004348079

- 1 : Compass switch
- 2 : Compass display

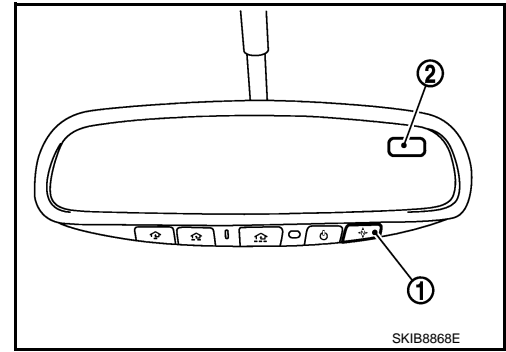

## Special Repair Requirement

INFOID:000000004348080

### 1.PERFORM ZONE VARIATION SETTING

Perform the zone variation setting. Refer to [MWI-34, "Description"](#).

>> GO TO 2.

### 2.PERFORM CALIBRATION

Perform the calibration. Refer to [MWI-34, "Description"](#).

>> Setting completion

# CLOCK

< SYSTEM DESCRIPTION >

## CLOCK

### Component Parts Location

INFOID:000000004348081

1 : Clock

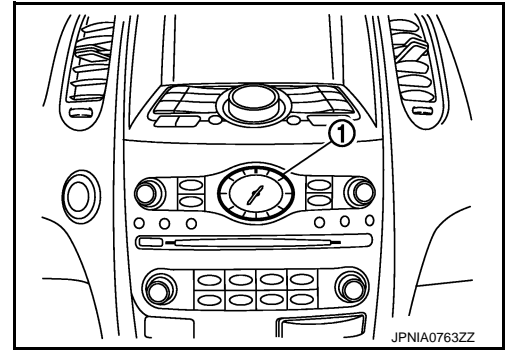

A  
B  
C  
D  
E  
F  
G  
H  
I  
J  
K  
L  
M  
O  
P

MWI

# DIAGNOSIS SYSTEM (METER)

< SYSTEM DESCRIPTION >

## DIAGNOSIS SYSTEM (METER)

### Diagnosis Description

INFOID:000000004348082

#### SELF-DIAGNOSIS MODE

- Information display LCD segment operation can be checked in self-diagnosis mode.
- Meters/gauges can be checked in self-diagnosis mode.

#### OPERATION PROCEDURE

1. Turn ignition switch ON, and switch the trip meter to "trip A" or "trip B".

**NOTE:**

If the diagnosis function is activated with "trip A" displayed, the mileage on "trip A" is reset to "0000.0". (The same way for "trip B".)

2. Turn ignition switch OFF.
3. While pressing the trip A/B reset switch (1), turn ignition switch ON again.
4. Make sure that the trip meter displays "0000.0".
5. Press the trip A/B reset switch at least 3 times. (Within 7 seconds after the ignition switch is turned ON.)

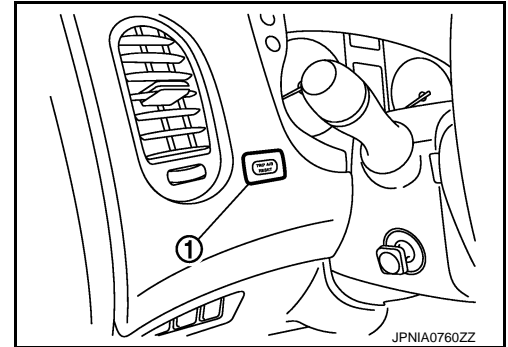

6. The unified meter control unit is turned to self-diagnosis mode.
  - Displays "888888" (1) and "8888.8" (2) in the information display LCD (3) for approximately 5 seconds and then blinks the segment dots of the information display LCD alternately.

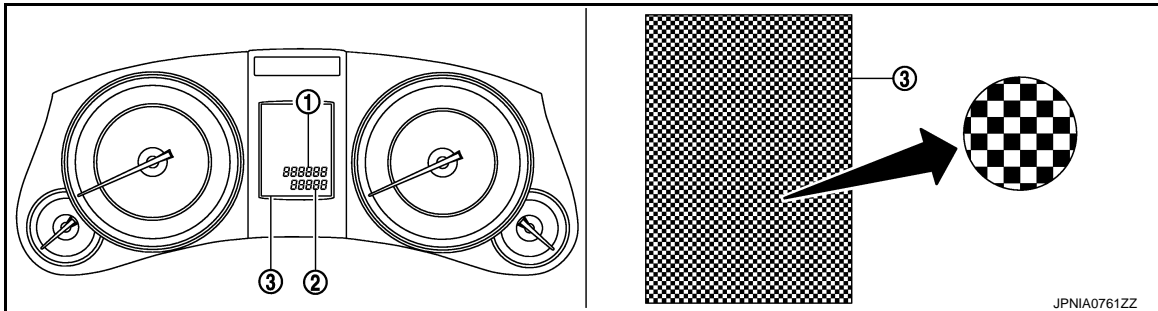

- Water temperature gauge and fuel gauge return to zero, and at the same time.

**NOTE:**

- Check combination meter power supply and ground circuit when self-diagnosis mode of combination meter does not start. Replace combination meter if normal.
- If any of the segments is not displayed, replace combination meter.

## DIAGNOSIS SYSTEM (METER)

### < SYSTEM DESCRIPTION >

7. Each meter activates during pressing trip A/B reset switch.

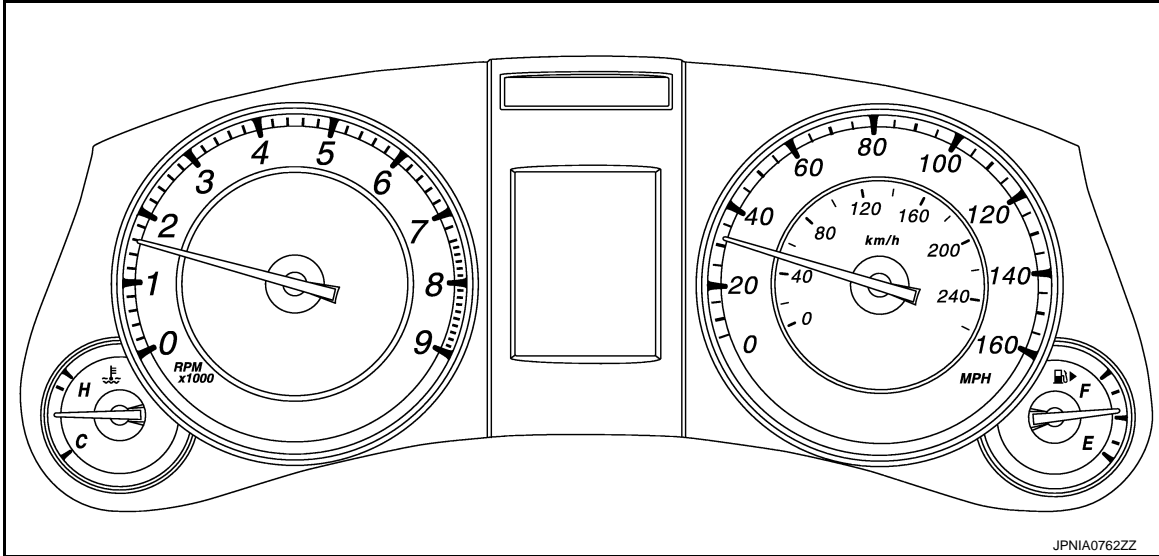

#### NOTE:

- If any of the meter and gages is not activated, replace combination meter.
- The figure is reference.

A  
B  
C  
D  
E  
F  
G  
H  
I  
J  
K  
L  
M  
O  
P

MWI

# DIAGNOSIS SYSTEM (UNIFIED METER AND A/C AMP.)

< SYSTEM DESCRIPTION >

## DIAGNOSIS SYSTEM (UNIFIED METER AND A/C AMP.)

### CONSULT-III Function (METER/M&A)

INFOID:000000004348083

#### CONSULT-III APPLICATION ITEMS

CONSULT-III can perform the following diagnosis modes with CAN communication with the unified meter and A/C amp.

System	Diagnosis mode	Description
METER/M&A	Self Diagnostic Result	Unified meter and A/C amp. checks the conditions and displays memorized error.
	Data Monitor	Displays unified meter and A/C amp. input/output data in real time.
	Ecu Identification	The unified meter and A/C amp. part number is displayed.

#### SELF DIAG RESULT

Refer to [MWI-100, "DTC Index"](#).

#### DATA MONITOR

##### Display Item List

X: Applicable

Display item [Unit]	MAIN SIGNALS	Description
SPEED METER [km/h] or [mph]	X	Value of vehicle speed signal received from ABS actuator and electric unit (control unit) with CAN communication line. <b>NOTE:</b> 655.35 is displayed when the malfunction signal is received.
SPEED OUTPUT [km/h] or [mph]	X	Vehicle speed signal value transmitted to other units with CAN communication line. <b>NOTE:</b> 655.35 is displayed when the malfunction signal is received.
ODO OUTPUT [km/h] or [mph]		Odometer signal value transmitted to other units with CAN communication line.
TACHO METER [rpm]	X	Value of the engine speed signal received from ECM with CAN communication line. <b>NOTE:</b> 8191.875 is displayed when the malfunction signal is received.
FUEL METER [L]	X	Fuel level indicated on combination meter.
W TEMP METER [°C] or [°F]	X	Value of engine coolant temperature signal received from ECM with CAN communication line. <b>NOTE:</b> 215 is displayed when the malfunction signal is input.
ABS W/L [On/Off]		Status of ABS warning lamp judged from ABS warning lamp signal received from ABS actuator and electric unit (control unit) with CAN communication line.
VDC/TCS IND [On/Off]		Status of VDC OFF indicator lamp judged from VDC OFF indicator lamp signal received from ABS actuator and electric unit (control unit) with CAN communication line.
SLIP IND [On/Off]		Status of SLIP indicator lamp judged from slip indicator lamp signal received from ABS actuator and electric unit (control unit) with CAN communication line.
BRAKE W/L [On/Off]		Status of brake warning lamp judged from brake warning lamp signal received from ABS actuator and electric unit (control unit) with CAN communication line. <b>NOTE:</b> Displays "Off" if the brake warning lamp is illuminated when the valve check starts, the parking brake switch is turned ON or the brake fluid level switch is turned ON.
DOOR W/L [On/Off]		Status of door warning judged from door switch signal received from BCM with CAN communication line.
HI-BEAM IND [On/Off]		Status of high beam indicator lamp judged from high beam request signal received from BCM with CAN communication line.



# DIAGNOSIS SYSTEM (UNIFIED METER AND A/C AMP.)

## < SYSTEM DESCRIPTION >

Display item [Unit]	MAIN SIGNALS	Description
TURN IND [On/Off]		Status of turn indicator lamp judged from turn indicator signal received from BCM with CAN communication line.
FR FOG IND [Off]		This item is displayed, but cannot be monitored.
RR FOG IND [Off]		This item is displayed, but cannot be monitored.
LIGHT IND [On/Off]		Status of tail lamp indicator lamp judged from position light request signal received from BCM with CAN communication line.
OIL W/L [On/Off]		Status of oil pressure warning lamp judged from oil pressure switch signal received from IPDM E/R with CAN communication line.
MIL [On/Off]		Status of malfunction indicator lamp judged from malfunctioning indicator lamp signal received from ECM with CAN communication line.
GLOW IND [Off]		This item is displayed, but cannot be monitored.
C-ENG2 W/L [Off]		This item is displayed, but cannot be monitored.
CRUISE IND [On/Off]		Status of CRUISE indicator judged from ASCD status signal received from ECM with CAN communication line.
SET IND [On/Off]		<ul style="list-style-type: none"> <li>• Status of SET indicator judged from ASCD status signal received from ECM with CAN communication line.</li> <li>• Status of SET indicator judged from meter display signal received from ICC sensor integrated unit with CAN communication line.</li> </ul>
CRUISE W/L [On/Off]		Status of CRUISE warning lamp judged from ICC warning lamp signal received from ICC sensor integrated unit with CAN communication line.
BA W/L [Off]		Status of IBA OFF indicator lamp judged from IBA OFF indicator lamp signal received from ICC sensor integrated unit with CAN communication line.
ATC/T-AMT W/L [On/Off]		Status of A/T check warning lamp judged from A/T check indicator signal received from TCM with CAN communication line.
4WD W/L [On/Off]		Status of AWD warning lamp judged from AWD warning lamp signal received from AWD control unit with CAN communication line.
4WD LOCK IND [Off]		This item is displayed, but cannot be monitored.
FUEL W/L [On/Off]		Low-fuel warning status judged by the identified fuel level.
WASHER W/L [On/Off]		Status of washer warning judged from washer level switch input to combination meter.
AIR PRES W/L [On/Off]		Status of low tire pressure warning lamp judged from tire pressure signal received from BCM with CAN communication line.
KEY G/Y W/L [On/Off]		Status of key warning lamp (G/Y) judged from key warning signal received from BCM with CAN communication line.
AFS OFF IND [On/Off]		Status of AFS OFF indicator lamp judged from AFS OFF indicator lamp signal received from AFS control unit with CAN communication line.
4WAS/RAS W/L [Off]		This item is displayed, but cannot be monitored.
DDS W/L [Off]		This item is displayed, but cannot be monitored.
LANE W/L [On/Off]		Status of lane departure warning lamp judged from lane departure warning lamp signal received from lane camera unit with CAN communication line.
LDP IND [On/Off]		Status of LDP ON indicator lamp judged from LDP ON indicator lamp signal received from lane camera unit with CAN communication line.
DCA IND [On/Off]		Status of DCA switch indicator judged from meter display signal received from ICC sensor integrated unit with CAN communication line.

A

B

C

D

E

F

G

H

I

J

K

L

M

MWI

O

P

## DIAGNOSIS SYSTEM (UNIFIED METER AND A/C AMP.)

### < SYSTEM DESCRIPTION >

Display item [Unit]	MAIN SIGNALS	Description
LCD [B&P N, B&P I, ID NG, ROTAT, SFT P, INSRT, BATT, NO KY, OUTKY, LK WN]		Displays status of Intelligent Key system warning judged from meter display signal received from BCM with CAN communication line.
ACC TARGET [On/Off]		Status of vehicle ahead detection indicator judged from meter display signal received from ICC sensor integrated unit with CAN communication line.
ACC DISTANCE [Off, SHORT, MID, LONG]		Status of set distance indicator judged from meter display signal received from ICC sensor integrated unit with CAN communication line.
ACC OWN VHL [On/Off]		Status of own vehicle indicator judged from meter display signal received from ICC sensor integrated unit with CAN communication line.
ACC SET SPEED		Status of set vehicle speed indicator judged from meter display signal received from ICC sensor integrated unit with CAN communication line.
ACC UNIT [On/Off]		Status of display unit judged from meter display signal received from ICC sensor integrated unit with CAN communication line.
SHIFT IND [P, R, N, D, L, M1, M2, M3, M4, M5]		Status of shift position indicator judged from shift position signal and manual mode indicator signal received from TCM with CAN communication line.
O/D OFF SW [Off]		This item is displayed, but cannot be monitored.
AT S MODE SW [On/Off]		Status of snow mode switch.
AT P MODE SW [Off]		This item is displayed, but cannot be monitored.
M RANGE SW [On/Off]		Status of manual mode switch.
NM RANGE SW [On/Off]		Status of not manual mode switch.
AT SFT UP SW [On/Off]		Status of manual mode shift up switch.
AT SFT DWN SW [On/Off]		Status of manual mode shift down switch.
ST SFT UP SW [Off]		This item is displayed, but cannot be monitored.
ST SFT DWN SW [Off]		This item is displayed, but cannot be monitored.
COMP F/B SIG [On/Off]		A/C compressor activation condition that ECM judges according to the water temperature and the acceleration degree.
4WD LOCK SW [Off]		This item is displayed, but cannot be monitored.
PKB SW [On/Off]		Status of parking brake switch.
BUCKLE SW [On/Off]		Status of seat belt buckle switch (driver side).
BRAKE OIL SW [On/Off]		Status of brake fluid level switch.
DISTANCE [km]		Value of possible driving distance calculated by unified meter and A/C amp.
OUTSIDE TEMP [°C] or [°F]		Ambient air temperature value converted from ambient sensor signal received from ambient sensor. <b>NOTE:</b> This may not match with the temperature value indicated on the information display. (Because the information display value is a corrected value from the ambient sensor input value.)

# DIAGNOSIS SYSTEM (UNIFIED METER AND A/C AMP.)

## < SYSTEM DESCRIPTION >

Display item [Unit]	MAIN SIGNALS	Description
FUEL LOW SIG [On/Off]		Status of fuel level low warning signal to output to AV control unit with CAN communication line.
BUZZER [On/Off]	X	Buzzer status (in the combination meter) is judged with the buzzer output signal received from each unit with CAN communication line and the warning output condition of the combination meter.

**NOTE:**

Some items are not available according to vehicle specification.

A  
B  
C  
D  
E  
F  
G  
H  
I  
J  
K  
L  
M  
O  
P

MWI

# U1000 CAN COMM CIRCUIT

< DTC/CIRCUIT DIAGNOSIS >

## DTC/CIRCUIT DIAGNOSIS

### U1000 CAN COMM CIRCUIT

#### Description

INFOID:000000004348084

CAN (Controller Area Network) is a serial communication line for real time application. It is an on-vehicle multiplex communication line with high data communication speed and excellent error detection ability. Many electronic control units are equipped onto a vehicle, and each control unit shares information and links with other control units during operation (not independent). In CAN communication, control units are connected with two communication lines (CAN-H line, CAN-L line) allowing a high rate of information transmission with less wiring. Each control unit transmits/receives data but selectively reads required data only.

CAN Communication Signal Chart. Refer to [LAN-16, "How to Use CAN Communication Signal Chart"](#).

#### DTC Logic

INFOID:000000004348085

#### DTC DETECTION LOGIC

DTC	Display contents of CONSULT-III	Diagnostic item is detected when ...	Probable malfunction location
U1000	CAN COMM CIRCUIT	When unified meter and A/C amp. is not transmitting or receiving CAN communication signal for 2 seconds or more.	CAN communication system

#### Diagnosis Procedure

INFOID:000000004348086

#### 1. PERFORM SELF DIAGNOSTIC

1. Turn ignition switch ON and wait for 2 seconds or more.
2. Check "Self Diagnostic Result" of "METER/M&A".

Is "CAN COMM CIRCUIT" displayed?

- YES >> Refer to [LAN-17, "Trouble Diagnosis Flow Chart"](#).  
NO >> Refer to [GI-40, "Intermittent Incident"](#).

# U1010 CONTROL UNIT (CAN)

< DTC/CIRCUIT DIAGNOSIS >

## U1010 CONTROL UNIT (CAN)

### Description

INFOID:000000004348087

Initial diagnosis of unified meter and A/C amp.

### DTC Logic

INFOID:000000004348088

### DTC DETECTION LOGIC

DTC	Display contents of CONSULT-III	Diagnostic item is detected when ...	Probable malfunction location
U1010	CONTROL UNIT (CAN)	If any malfunction is detected during initial diagnosis of unified meter and A/C amp. CAN controller	Unified meter and A/C amp.

### Diagnosis Procedure

INFOID:000000004348089

#### 1. REPLACE UNIFIED METER AND A/C AMP.

When DTC "U1010" is detected, replace unified meter and A/C amp.

>> INSPECTION END

A  
B  
C  
D  
E  
F  
G  
H  
I  
J  
K  
L  
M  
O  
P

MWI

# B2201 COMMUNICATION ERROR 1

< DTC/CIRCUIT DIAGNOSIS >

## B2201 COMMUNICATION ERROR 1

### Description

INFOID:000000004348090

The communication line (LCD <-> AMP.) is used to communicate signals between the combination meter and the unified meter and A/C amp. in order to control the information display.

### DTC Logic

INFOID:000000004348091

### DTC DETECTION LOGIC

DTC	Display contents of CONSULT-III	Diagnostic item is detected when ...	Probable malfunction location
B2201	COMM ERROR 1	If a communication error is present in the communication line (LCD <-> AMP.) for 2 seconds or more	Communication line (LCD <-> AMP.) circuit

### Diagnosis Procedure

INFOID:000000004348092

#### 1. CHECK CONNECTOR

Check combination meter, unified meter and A/C amp. and terminals (combination meter side, unified meter and A/C amp. side, and harness side) for looseness or bent.

Is the inspection result normal?

YES >> GO TO 2.

NO >> Repair terminal or connector.

#### 2. CHECK CONTINUITY COMMUNICATION CIRCUIT

1. Turn ignition switch OFF.
2. Disconnect combination meter connector and unified meter and A/C amp. connector.
3. Check continuity between combination meter harness connector and unified meter and A/C amp. harness connector.

Combination meter		Unified meter and A/C amp.		Continuity
Connector	Terminal	Connector	Terminal	
M53	24	M66	14	Existed
	25		34	

4. Check continuity between combination meter harness connector and ground.

Combination meter		Ground	Continuity
Connector	Terminal		
M53	24		Not existed
	25		

Is the inspection result normal?

YES >> GO TO 3.

NO >> Repair harness or connector.

#### 3. CHECK UNIFIED METER AND A/C AMP. OUTPUT VOLTAGE

1. Connect unified meter and A/C amp. connector.
2. Turn ignition switch ON.
3. Check voltage between unified meter and A/C amp. harness connector and ground.

# B2201 COMMUNICATION ERROR 1

## < DTC/CIRCUIT DIAGNOSIS >

Terminals		Voltage (Approx.)
(+)	(-)	
Unified meter and A/C amp.		12 V
Connector	Terminal	
M66	14	

Is the inspection result normal?

YES >> GO TO 4.

NO >> Replace unified meter and A/C amp.

### 4. CHECK COMBINATION METER OUTPUT VOLTAGE

1. Turn ignition switch OFF.
2. Disconnect unified meter and A/C amp. connector.
3. Connect combination meter connector.
4. Turn ignition switch ON.
5. Check voltage between combination meter harness connector and ground.

Terminal		Voltage (Approx.)
(+)	(-)	
Combination meter		5 V
Connector	Terminal	
M53	25	

Is the inspection result normal?

YES >> INSPECTION END

NO >> Replace combination meter.

A  
B  
C  
D  
E  
F  
G  
H  
I  
J  
K  
L  
M  
O  
P

MWI

# B2202 COMMUNICATION ERROR 2

< DTC/CIRCUIT DIAGNOSIS >

## B2202 COMMUNICATION ERROR 2

### Description

INFOID:000000004348093

The communication line (METER <-> AMP.) is used to communicate signals between the combination meter and the unified meter and A/C amp. in order to control the information display.

### DTC Logic

INFOID:000000004348094

### DTC DETECTION LOGIC

DTC	Display contents of CONSULT-III	Diagnostic item is detected when ...	Probable malfunction location
B2202	COMM ERROR 2	If a communication error is present in the communication line (METER <-> AMP.) for 2 seconds or more	Communication line (METER <-> AMP.) circuit

### Diagnosis Procedure

INFOID:000000004348095

#### 1. CHECK CONNECTOR

Check combination meter, unified meter and A/C amp. and terminals (combination meter side, unified meter and A/C amp. side, and harness side) for looseness or bent.

Is the inspection result normal?

YES >> GO TO 2.

NO >> Repair terminal or connector.

#### 2. CHECK CONTINUITY COMMUNICATION CIRCUIT

1. Turn ignition switch OFF.
2. Disconnect combination meter connector and unified meter and A/C amp. connector.
3. Check continuity between combination meter harness connector and unified meter and A/C amp. harness connector.

Combination meter		Unified meter and A/C amp.		Continuity
Connector	Terminal	Connector	Terminal	
M53	2	M66	27	Existed
	3		7	

4. Check continuity between combination meter harness connector and ground.

Combination meter		Ground	Continuity
Connector	Terminal		
M53	2		Not existed
	3		

Is the inspection result normal?

YES >> GO TO 3.

NO >> Repair harness or connector.

#### 3. CHECK UNIFIED METER AND A/C AMP. OUTPUT VOLTAGE

1. Connect unified meter and A/C amp. connector.
2. Turn ignition switch ON.
3. Check voltage between unified meter and A/C amp. harness connector and ground.



## B2202 COMMUNICATION ERROR 2

< DTC/CIRCUIT DIAGNOSIS >

Terminals		Voltage (Approx.)
(+)	(-)	
Unified meter and A/C amp.		5 V
Connector	Terminal	
M66	27	

Is the inspection result normal?

YES >> GO TO 4.

NO >> Replace unified meter and A/C amp.

### 4. CHECK COMBINATION METER OUTPUT VOLTAGE

1. Turn ignition switch OFF.
2. Disconnect unified meter and A/C amp. connector.
3. Connect combination meter connector.
4. Turn ignition switch ON.
5. Check voltage between combination meter harness connector and ground.

Terminals		Voltage (Approx.)
(+)	(-)	
Combination meter		5 V
Connector	Terminal	
M53	3	

Is the inspection result normal?

YES >> INSPECTION END

NO >> Replace combination meter.

A  
B  
C  
D  
E  
F  
G  
H  
I  
J  
K  
L  
M  
O  
P

MWI

# B2205 VEHICLE SPEED

< DTC/CIRCUIT DIAGNOSIS >

## B2205 VEHICLE SPEED

### Description

INFOID:000000004348096

Vehicle speed signal is transmitted from ABS actuator and electric unit (control unit) via CAN communication to unified meter and A/C amp.

### DTC Logic

INFOID:000000004348097

### DTC DETECTION LOGIC

DTC	Display contents of CONSULT-III	Diagnostic item is detected when ...	Probable malfunction location
B2205	VEHICLE SPEED	If the abnormal vehicle speed signal is input from ABS actuator and electric unit (control unit) for 2 seconds or more	<ul style="list-style-type: none"><li>• Wheel sensor</li><li>• ABS actuator and electric unit (control unit)</li></ul>

### Diagnosis Procedure

INFOID:000000004348098

#### 1. PERFORM SELF-DIAGNOSIS OF ABS ACTUATOR AND ELECTRIC UNIT (CONTROL UNIT)

Perform "Self Diagnostic Result" of ABS actuator and electric unit (control unit), and repair or replace malfunctioning parts.

>> Refer to [BRC-31, "CONSULT-III Function"](#).

# B2267 ENGINE SPEED

< DTC/CIRCUIT DIAGNOSIS >

## B2267 ENGINE SPEED

### Description

INFOID:000000004348099

The engine speed signal is transmitted from ECM to the unified meter and A/C amp. with CAN communication.

### DTC Logic

INFOID:000000004348100

### DTC DETECTION LOGIC

DTC	Display contents of CONSULT-III	Diagnostic item is detected when ...	Probable malfunction location
B2267	ENGINE SPEED	If ECM continuously transmits abnormal engine speed signals for 2 seconds or more	<ul style="list-style-type: none"><li>• Crankshaft position sensor (POS)</li><li>• ECM</li></ul>

### Diagnosis Procedure

INFOID:000000004348101

#### 1. PERFORM SELF-DIAGNOSIS OF ECM

Perform "Self Diagnostic Result" of ECM, and repair or replace malfunctioning parts.

>> Refer to [EC-117. "CONSULT-III Function"](#).

A  
B  
C  
D  
E  
F  
G  
H  
I  
J  
K  
L  
M  
O  
P

MWI

# B2268 WATER TEMP

< DTC/CIRCUIT DIAGNOSIS >

## B2268 WATER TEMP

### Description

INFOID:000000004348102

The engine coolant temperature signal is transmitted from ECM to the unified meter and A/C amp. via CAN communication.

### DTC Logic

INFOID:000000004348103

### DTC DETECTION LOGIC

DTC	Display contents of CONSULT-III	Diagnostic item is detected when ...	Probable malfunction location
B2268	WATER TEMP	If ECM continuously transmits abnormal engine coolant temperature signals for 60 seconds or more	<ul style="list-style-type: none"><li>• Engine coolant temperature sensor</li><li>• ECM</li></ul>

### Diagnosis Procedure

INFOID:000000004348104

#### 1. PERFORM SELF-DIAGNOSIS OF ECM

Perform "Self Diagnosis Result" of ECM, and repair or replace malfunctioning parts.

>> Refer to [EC-117. "CONSULT-III Function"](#).

# POWER SUPPLY AND GROUND CIRCUIT

< DTC/CIRCUIT DIAGNOSIS >

## POWER SUPPLY AND GROUND CIRCUIT COMBINATION METER

### COMBINATION METER : Diagnosis Procedure

INFOID:000000004348105

#### 1.CHECK FUSE

Check for blown fuses.

Power source	Fuse No.
Battery	11
Ignition switch ON or START	4

Is the inspection result normal?

YES >> GO TO 2.

NO >> Be sure to eliminate cause of malfunction before installing new fuse.

#### 2.CHECK POWER SUPPLY CIRCUIT

Check voltage between combination meter harness connector and ground.

Terminals			Ignition switch position	Value (Approx.)
(+)		(-)		
Combination meter	Terminal	Signal name		
M53	1	Battery power supply	OFF	Battery voltage
	21	Ignition signal	ON	

Is the inspection result normal?

YES >> GO TO 3.

NO >> Check harness between combination meter and fuse.

#### 3.CHECK GROUND CIRCUIT

1. Turn ignition switch OFF.
2. Disconnect combination meter connector.
3. Check continuity between combination meter harness connector and ground.

Combination meter		Ground	Continuity
Connector	Terminal		
M53	5		Existed
	15		
	22		

Is the inspection result normal?

YES >> INSPECTION END

NO >> Repair harness or connector.

## UNIFIED METER AND A/C AMP.

### UNIFIED METER AND A/C AMP. : Diagnosis Procedure

INFOID:000000004348106

#### 1.CHECK FUSE

Check for blown fuses.

Power source	Fuse No.
Battery	11
Ignition switch ACC or ON	19
Ignition switch ON or START	3

# POWER SUPPLY AND GROUND CIRCUIT

## < DTC/CIRCUIT DIAGNOSIS >

### Is the inspection result normal?

YES >> GO TO 2.

NO >> Be sure to eliminate cause of malfunction before installing new fuse.

## 2.CHECK POWER SUPPLY CIRCUIT

Check voltage between unified meter and A/C amp. harness connector and ground.

Terminals			Ignition switch position	Value (Approx.)
(+)		(-)		
Unified meter and A/C amp.	Terminal		Signal name	
M67	54	Battery power supply	OFF	Battery voltage
	41	ACC power supply	ACC	
	53	Ignition signal	ON	

### Is the inspection result normal?

YES >> GO TO 3.

NO >> Check harness between unified meter and A/C amp. and fuse.

## 3.CHECK GROUND CIRCUIT

1. Turn ignition switch OFF.
2. Disconnect unified meter and A/C amp. connector.
3. Check continuity between unified meter and A/C amp. harness connector and ground.

Unified meter and A/C amp.		Ground	Continuity
Connector	Terminal		
M67	55		Existed
	71		

### Is the inspection result normal?

YES >> INSPECTION END

NO >> Repair harness or connector.

## IPDM E/R (INTELLIGENT POWER DISTRIBUTION MODULE ENGINE ROOM)

### IPDM E/R (INTELLIGENT POWER DISTRIBUTION MODULE ENGINE ROOM) : Di-agnosis Procedure

INFOID:000000004683993

## 1.CHECK FUSES AND FUSIBLE LINK

Check that the following IPDM E/R fuses or fusible links are not blown.

Signal name	Fuses and fusible link No.
Battery power supply	C
	50
	51

### Is the fuse fusing?

YES >> Replace the blown fuse or fusible link after repairing the affected circuit if a fuse or fusible link is blown.

NO >> GO TO 2.

## 2.CHECK POWER SUPPLY CIRCUIT

1. Turn the ignition switch OFF.
2. Disconnect IPDM E/R connector.
3. Check voltage between IPDM E/R harness connector and the ground.

# POWER SUPPLY AND GROUND CIRCUIT

## < DTC/CIRCUIT DIAGNOSIS >

Terminals		Voltage (Approx.)
(+)	(-)	
IPDM E/R		Battery voltage
Connector	Terminal	
E4	1	

Is the measurement value normal?

YES >> GO TO 3.

NO >> Repair the harness or connector.

### 3.CHECK GROUND CIRCUIT

Check continuity between IPDM E/R harness connectors and the ground.

IPDM E/R		Ground	Continuity
Connector	Terminal		
E5	12		Existed
E6	41		

Does continuity exist?

YES >> INSPECTION END

NO >> Repair the harness or connector.

A  
B  
C  
D  
E  
F  
G  
H  
I  
J  
K  
L  
M  
O  
P

MWI

# FUEL LEVEL SENSOR SIGNAL CIRCUIT

< DTC/CIRCUIT DIAGNOSIS >

## FUEL LEVEL SENSOR SIGNAL CIRCUIT

### Description

INFOID:000000004348109

The fuel level sensor unit and fuel pump (main) and the fuel level sensor unit (sub) detect the fuel level in the fuel tank and transmit the fuel gauge signal to the unified meter and A/C amp.

### Component Function Check

INFOID:000000004348110

#### 1. CHECK UNIFIED METER AND A/C AMP. OUTPUT SIGNAL

Select the "Data Monitor" for the "METER/M&A" and compare the "FUEL METER" monitor value with the fuel gauge reading on the combination meter.

Fuel gauge pointer	Reference value of data monitor [L]
Full	Approx. 73.8
Three quarters	Approx. 59.2
Half	Approx. 40.7
A quarter	Approx. 20.9
Empty	Approx. 8.8

Does monitor value match fuel gauge reading?

- YES >> INSPECTION END  
 NO >> Replace combination meter.

### Diagnosis Procedure

INFOID:000000004348111

#### 1. CHECK UNIFIED METER AND A/C AMP. INPUT SIGNAL

- Turn ignition switch ON.
- Check voltage between unified meter and A/C amp. harness connector and ground.

Terminals		Voltage (Approx.)
(+)	(-)	
Unified meter and A/C amp.		<p style="text-align: right;">JSNIA0013GB</p>
Connector	Terminal	
M67	42	
		Ground

Does it match fuel gauge reading?

- YES >> GO TO 2.  
 NO >> Replace unified meter and A/C amp.

#### 2. CHECK FUEL LEVEL SENSOR (SUB) CIRCUIT

- Turn ignition switch OFF.
- Disconnect unified meter and A/C amp. connector and fuel level sensor unit (sub) connector.
- Check continuity between unified meter and A/C amp. harness connector and fuel level sensor unit (sub) harness connector.

Unified meter and A/C amp.		Fuel level sensor unit (sub)		Continuity
Connector	Terminal	Connector	terminal	
M67	42	B21	1	Existed



# FUEL LEVEL SENSOR SIGNAL CIRCUIT

## < DTC/CIRCUIT DIAGNOSIS >

4. Check continuity between unified meter and A/C amp. harness connector and ground.

Unified meter and A/C amp.		Ground	Continuity
Connector	Terminal		
M67	42		Not existed

Is the inspection result normal?

YES >> GO TO 3.

NO >> Repair harness or connector.

### 3.CHECK FUEL LEVEL SENSOR (MAIN-SUB) CIRCUIT

1. Disconnect fuel level sensor unit and fuel pump (main) connector.  
 2. Check continuity between fuel level sensor unit (sub) harness connector and fuel level sensor unit and fuel pump (main) harness connector.

Fuel level sensor unit (sub)		Fuel level sensor unit and fuel pump (main)		Continuity
Connector	Terminal	Connector	terminal	
B21	2	B22	2	Existed

3. Check continuity between fuel level sensor unit (sub) harness connector and ground.

Fuel level sensor unit (sub)		Ground	Continuity
Connector	Terminal		
B21	2		Not existed

Is the inspection result normal?

YES >> GO TO 4.

NO >> Repair harness or connector.

### 4.CHECK FUEL LEVEL SENSOR (MAIN) CIRCUIT

Check continuity between fuel level sensor unit and fuel pump (main) harness connector and unified meter and A/C amp. harness connector.

Fuel level sensor unit and fuel pump (main)		Unified meter and A/C amp.		Continuity
Connector	Terminal	Connector	terminal	
B22	5	M67	58	Existed

Is the inspection result normal?

YES >> INSPECTION END

NO >> Repair harness or connector.

## Component Inspection

INFOID:000000004348112

### 1.REMOVE FUEL LEVEL SENSOR UNIT

Remove the fuel level sensor unit. Refer to [FL-5, "Removal and Installation"](#).

>> GO TO 2.

### 2.CHECK FUEL LEVEL SENSOR UNIT AND FUEL PUMP (MAIN)

A  
B  
C  
D  
E  
F  
G  
H  
I  
J  
K  
L  
M  
O  
P

MWI

# FUEL LEVEL SENSOR SIGNAL CIRCUIT

## < DTC/CIRCUIT DIAGNOSIS >

Check the resistance between fuel level sensor unit and fuel pump (main).

Fuel level sensor unit and fuel pump (main)		Condition *	Resistance (Approx.)
Terminal			
2	5	Full (A)	3 Ω
		Empty (B)	80 Ω

\*: When float rod is contact with stopper.

Standard float position

Float position [mm (in)]*	
Full (A)	Approx. 194 (7.64)
Empty (B)	Approx. 30 (1.18)

\*: When float rod is contact with stopper.

Is the inspection result normal?

YES >> GO TO 3.

NO >> Replace fuel level sensor unit and fuel pump (main).

### 3.CHECK FUEL LEVEL SENSOR UNIT (SUB)

Inspect the resistance of fuel level sensor unit (sub).

Fuel level sensor unit (sub)		Condition *	Resistance (Approx.)
Terminal			
1	2	Full (A)	3 Ω
		Empty (B)	43 Ω

\*: When float rod is contact with stopper.

Standard float position

Float position [mm (in)]*	
Full (A)	Approx. 32 (1.26)
Empty (B)	Approx. 203 (7.99)

\*: When float rod is contact with stopper.

Is the inspection result normal?

YES >> INSPECTION END

NO >> Replace fuel level sensor unit (sub).

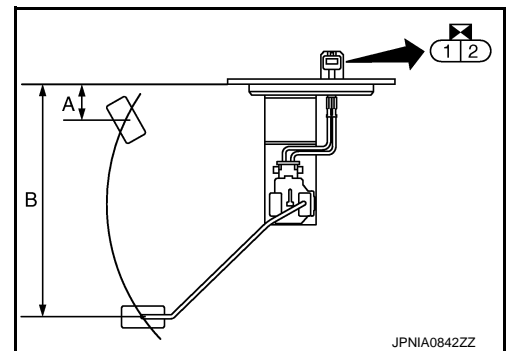
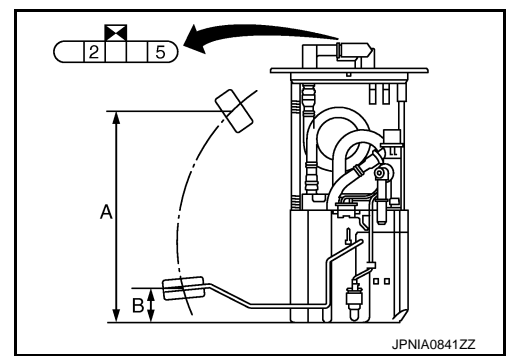

# METER CONTROL SWITCH SIGNAL CIRCUIT





< DTC/CIRCUIT DIAGNOSIS >

## METER CONTROL SWITCH SIGNAL CIRCUIT

### Description

INFOID:000000004348113

Transmits the following signals to the combination meter.





-  (Illumination control) switch signal (+)
-  (Illumination control) switch signal (-)
-  (select) switch signal
-  (enter) switch signal

### Diagnosis Procedure

INFOID:000000004348114

#### 1. CHECK METER CONTROL SWITCH INPUT SIGNAL

1. Turn ignition switch ON.
2. Measure voltage between the following terminals of the combination meter.

Combination meter		Condition	Voltage (Approx.)	
Connector	Terminal			
	(+)	(-)		
M53	36	16	When  (select) switch is pressed	0 V
			Other than the above	5 V
	37	16	When  (enter) switch is pressed	0 V
			Other than the above	5 V
	39	16	When  (illumination control) switch is pressed	0 V
			Other than the above	5 V
	40	16	When  (illumination control) switch is pressed	0 V
			Other than the above	5 V

Is the inspection result normal?

- YES >> INSPECTION END  
 NO >> GO TO 2.

#### 2. CHECK METER CONTROL SWITCH SIGNAL CIRCUIT

1. Turn ignition switch OFF.
2. Disconnect the combination meter and meter control switch connectors.
3. Check continuity between combination meter harness connector and meter control switch harness connector.

Combination meter		Meter control switch		Continuity
Connector	Terminal	Connector	Terminal	
M53	16	M54	2	Existed
	36		6	
	37		7	
	39		3	
	40		1	

4. Check continuity between combination meter harness connector and ground.

# METER CONTROL SWITCH SIGNAL CIRCUIT

< DTC/CIRCUIT DIAGNOSIS >

Combination meter		Ground	Continuity
Connector	Terminal		
M53	16	Ground	Not existed
	36		
	37		
	39		
	40		

Is the inspection result normal?

YES >> INSPECTION END





NO >> Repair harness or connector.

## Component Inspection

INFOID:000000004348115

### 1. CHECK METER CONTROL SWITCH UNIT

1. Turn ignition switch OFF.
2. Disconnect the meter control switch connector.
3. Check continuity between the following terminals of the meter control switch.

Combination meter		Operation and status	Continuity	
Connector	Terminal			
M54	6	2	Press  (select) switch	Existed
			Other than the above	Not existed
	7	2	Press  (enter) switch	Existed
			Other than the above	Not existed
	3	2	Press  (illumination control) switch	Existed
			Other than the above	Not existed
	1	2	Press  (illumination control) switch	Existed
			Other than the above	Not existed

Is inspection result normal?

YES >> INSPECTION END

NO >> Replace meter control switch.

# TRIP A/B RESET SWITCH SIGNAL CIRCUIT

< DTC/CIRCUIT DIAGNOSIS >

## TRIP A/B RESET SWITCH SIGNAL CIRCUIT

### Description

INFOID:000000004348116

Transmits the trip A/B reset switch signals to the combination meter.

### Diagnosis Procedure

INFOID:000000004348117

#### 1. CHECK TRIP A/B RESET SWITCH INPUT SIGNAL

1. Turn ignition switch ON.
2. Measure voltage between the combination meter harness connector terminals.

Combination meter			Condition	Voltage (Approx.)
Connector	Terminal			
	(+)	(-)		
M53	38	16	When trip A/B reset switch is pressed	0 V
			Other than the above	5 V

Is the inspection result normal?

- YES >> INSPECTION END  
NO >> GO TO 2.

#### 2. CHECK TRIP A/B RESET SWITCH SIGNAL CIRCUIT

1. Turn ignition switch OFF.
2. Disconnect the combination meter and meter control switch connectors.
3. Check continuity between combination meter harness connector and trip A/B reset switch harness connector.

Combination meter		Trip A/B reset switch		Continuity
Connector	Terminal	Connector	Terminal	
M53	38	M56	1	Existed
	16		2	

4. Check continuity between combination meter harness connector and ground.

Combination meter		Ground	Continuity
Connector	Terminal		
M53	38		Continuity
	16	Not existed	

Is the inspection result normal?

- YES >> INSPECTION END  
NO >> Repair harness or connector.

### Component Inspection

INFOID:000000004348118

#### 1. CHECK TRIP A/B RESET SWITCH UNIT

1. Turn ignition switch OFF.
2. Disconnect the trip A/B reset switch connector.
3. Check continuity between the trip A/B reset switch connector terminals.

A  
B  
C  
D  
E  
F  
G  
H  
I  
J  
K  
L  
M  
O  
P

MWI

## TRIP A/B RESET SWITCH SIGNAL CIRCUIT

< DTC/CIRCUIT DIAGNOSIS >

---

Trip A/B reset switch		Operation and status	Continuity
Terminal			
1	2	Press trip A/B reset switch	Existed
		Other than the above	Not existed

Is inspection result normal?

YES >> INSPECTION END

NO >> Replace trip A/B reset switch.

# OIL PRESSURE SWITCH SIGNAL CIRCUIT

< DTC/CIRCUIT DIAGNOSIS >

## OIL PRESSURE SWITCH SIGNAL CIRCUIT

### Description

INFOID:000000004348119

Detects the engine oil pressure and transmits the oil pressure switch signal to IPDM E/R.

### Component Function Check

INFOID:000000004348120

#### 1. CHECK UNIFIED METER AND A/C AMP. INPUT SIGNAL

Select the "Data Monitor" for the "METER/M&A" and check the "OIL W/L" monitor value.

"OIL W/L"

Ignition switch ON : On

Engine running : Off

>> INSPECTION END

### Diagnosis Procedure

INFOID:000000004348121

#### 1. CHECK OIL PRESSURE SWITCH CIRCUIT

1. Turn ignition switch OFF.
2. Disconnect IPDM E/R connector and oil pressure switch connector.
3. Check continuity between IPDM E/R harness connector and oil pressure switch harness connector.

IPDM E/R		Oil pressure switch		Continuity
Connector	Terminal	Connector	Terminal	
E7	75	F37	1	Existed

4. Check continuity between IPDM E/R harness connector and ground.

IPDM E/R		Ground	Continuity
Connector	Terminal		
E7	75		Not existed

Is the inspection result normal?

YES >> INSPECTION END

NO >> Repair harness or connector.

### Component Inspection

INFOID:000000004348122

#### 1. CHECK OIL PRESSURE SWITCH UNIT

Check continuity between oil pressure switch and ground.

Condition	Continuity
Engine stopped	Existed
Engine running	Not existed

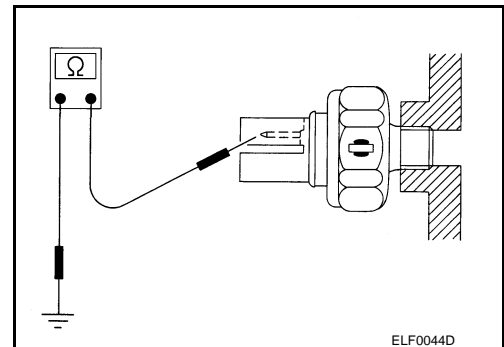

Is the inspection result normal?

YES >> INSPECTION END

NO >> Replace oil pressure switch.

# PARKING BRAKE SWITCH SIGNAL CIRCUIT

< DTC/CIRCUIT DIAGNOSIS >

## PARKING BRAKE SWITCH SIGNAL CIRCUIT

### Description

INFOID:000000004348123

Transmits the parking brake switch signal to the combination meter.

### Diagnosis Procedure

INFOID:000000004348124

#### 1. CHECK COMBINATION METER INPUT SIGNAL

1. Turn ignition switch ON.
2. Check the voltage and waveform between combination meter harness connector and ground.

Terminals		Condition	Voltage and waveform
(+)	(-)		
Combination meter			
Connector	Terminal	Parking brake applied	Approx. 0 V
M53	27		

Is the inspection result normal?

- YES >> INSPECTION END  
 NO >> GO TO 2.

#### 2. CHECK PARKING BRAKE SWITCH SIGNAL CIRCUIT

1. Turn ignition switch OFF.
2. Disconnect combination meter connector and parking brake switch connector.
3. Check continuity between combination meter harness connector and parking brake switch harness connector.

Combination meter		Parking brake switch		Continuity
Connector	Terminal	Connector	Terminal	
M53	27	E107	1	Existed

4. Check continuity between combination meter harness connector and ground.

Combination meter		Ground	Continuity
Connector	Terminal		
M53	27		

Is the inspection result normal?

- YES >> INSPECTION END  
 NO >> Repair harness or connector.

### Component Inspection

INFOID:000000004348125

#### 1. CHECK PARKING BRAKE SWITCH

Check parking brake switch. Refer to [BRC-78, "Component Inspection"](#).

Is the inspection result normal?

- YES >> INSPECTION END.



# PARKING BRAKE SWITCH SIGNAL CIRCUIT

< DTC/CIRCUIT DIAGNOSIS >

---

NO >> Replace parking brake switch.

A

B

C

D

E

F

G

H

I

J

K

L

M

MWI

O

P

# WASHER LEVEL SWITCH SIGNAL CIRCUIT

< DTC/CIRCUIT DIAGNOSIS >

## WASHER LEVEL SWITCH SIGNAL CIRCUIT

### Description

INFOID:000000004348126

Transmits the washer level switch signal to the combination meter.

### Diagnosis Procedure

INFOID:000000004348127

#### 1. CHECK WASHER LEVEL SWITCH SIGNAL CIRCUIT

1. Turn ignition switch OFF.
2. Disconnect combination meter connector and washer level switch connector.
3. Check continuity between combination meter harness connector and washer level switch harness connector.

Combination meter		Washer level switch		Continuity
Connector	Terminal	Connector	Terminal	
M53	31	E32	1	Existed

4. Check continuity between combination meter harness connector and ground.

Combination meter		Ground	Continuity
Connector	Terminal		
M53	31		Not existed

5. Check continuity between washer level switch harness connector and ground.

Washer level switch		Ground	Continuity
Connector	Terminal		
E32	2		Existed

Is the inspection result normal?

- YES >> INSPECTION END  
NO >> Repair harness or connector.

### Component Inspection

INFOID:000000004348128

#### 1. CHECK WASHER LEVEL SWITCH

1. Turn ignition switch OFF.
2. Disconnect washer level switch connector.
3. Check washer level switch.

Terminal		Condition	Continuity
1	2	Washer fluid level is low (washer level switch ON)	Existed
		Washer fluid level is normal (washer level switch OFF)	Not existed

Is the inspection result normal?

- YES >> INSPECTION END  
NO >> Replace washer level switch. Refer to [WW-103, "Removal and Installation"](#).

COMPASS

< DTC/CIRCUIT DIAGNOSIS >

COMPASS

Wiring Diagram - COMPASS -

INFOID:000000004348129

PM: With automatic drive positioner  
OP: Without automatic drive positioner

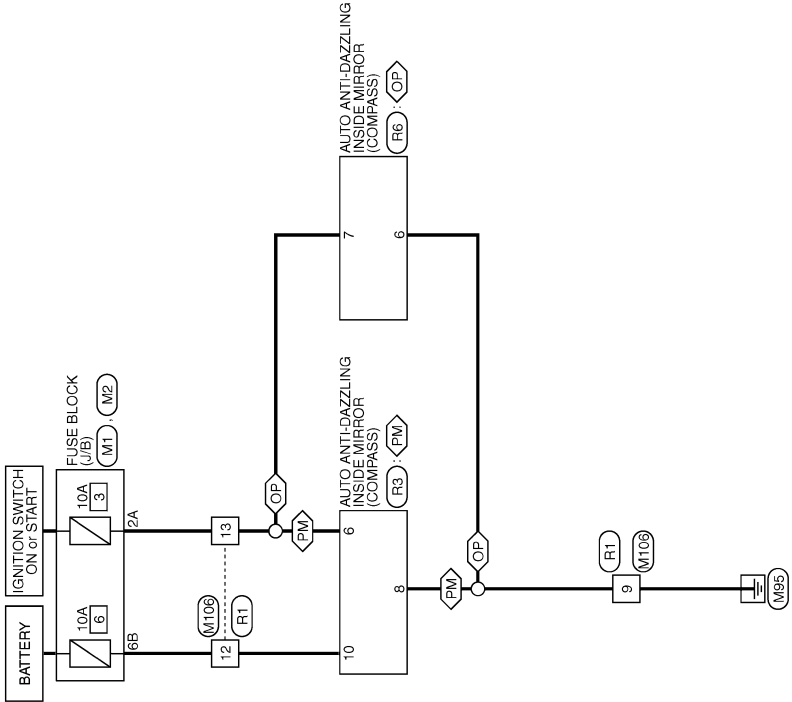

COMPASS

2008/08/28

JCNWA1797GB

A  
B  
C  
D  
E  
F  
G  
H  
I  
J  
K  
L  
M  
N  
O  
P

MWI

# COMPASS

## < DTC/CIRCUIT DIAGNOSIS >

### COMPASS

Connector No.	M1
Connector Name	FUSE BLOCK (J/B)
Connector Type	NS06FW-M2



Terminal No.	2A	Color of Wire	G	Signal Name [Specification]	
--------------	----	---------------	---	-----------------------------	--

Connector No.	M2
Connector Name	FUSE BLOCK (J/B)
Connector Type	NS10FW-CS



Terminal No.	6B	Color of Wire	Y	Signal Name [Specification]	
--------------	----	---------------	---	-----------------------------	--

Connector No.	M106
Connector Name	WIRE TO WIRE
Connector Type	TK10MW-NS

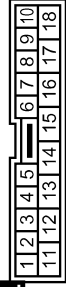

Terminal No.	9	Color of Wire	B	Signal Name [Specification]	
12	Y				
13	BR				

Connector No.	R1
Connector Name	WIRE TO WIRE
Connector Type	TK10FW-NS



Terminal No.	9	Color of Wire	B	Signal Name [Specification]	
12	G				
13	BR				

Connector No.	R3
Connector Name	AUTO ANTI-DAZZLING INSIDE MIRROR
Connector Type	TH10FB-NH

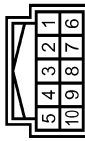

Terminal No.	6	Color of Wire	BR	Signal Name [Specification]	IGN
8	B				GND
10	G				BAT

Connector No.	R6
Connector Name	AUTO ANTI-DAZZLING INSIDE MIRROR
Connector Type	JAA07FB



Terminal No.	6	Color of Wire	B	Signal Name [Specification]	
7	BR				

# CLOCK

< DTC/CIRCUIT DIAGNOSIS >

## CLOCK

Wiring Diagram - CLOCK -

INFOID:000000004348130

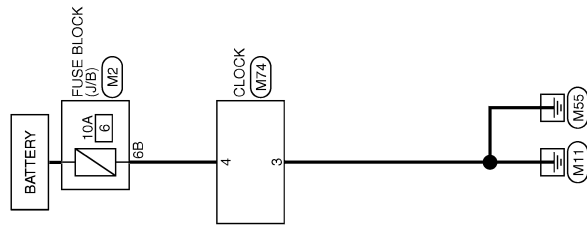

CLOCK

2008/08/28

JCNWA1799GB

A  
B  
C  
D  
E  
F  
G  
H  
I  
J  
K  
L  
M  
N  
O  
P

MWI

# CLOCK

## < DTC/CIRCUIT DIAGNOSIS >

### CLOCK

Connector No.	M2
Connector Name	FUSE BLOCK (L/E)
Connector Type	HS10FW-GS



Terminal No.	6B	Y	—
Color of Wire	Y		
Signal Name [Specification]			

Connector No.	M74
Connector Name	CLOCK
Connector Type	TH04FW-NH



Terminal No.	3	B	
Color of Wire	B		
Signal Name [Specification]	GND		
Terminal No.	4	Y	BAT
Color of Wire	Y		
Signal Name [Specification]	BAT		

JCNWA1800GB

# COMBINATION METER

< ECU DIAGNOSIS INFORMATION >

## ECU DIAGNOSIS INFORMATION

### COMBINATION METER

Reference Value

INFOID:000000004348131

VALUES ON THE DIAGNOSIS TOOL

Refer to [MWI-84, "Reference Value"](#).

TERMINAL LAYOUT

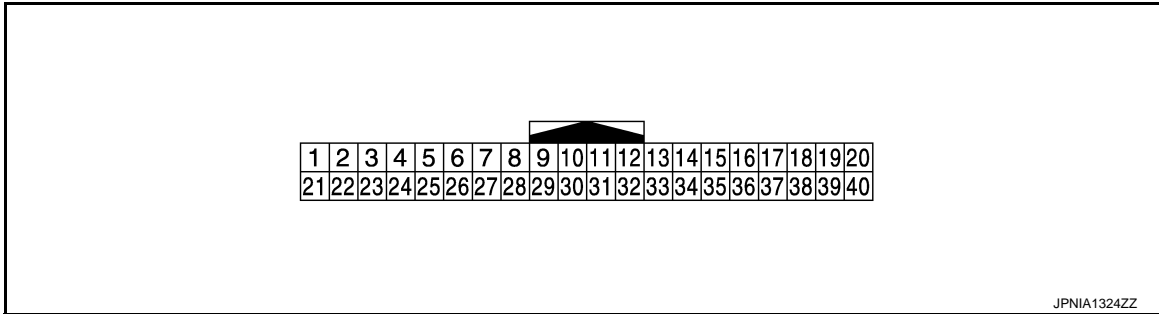

PHYSICAL VALUES

Terminal No. (Wire color)		Description		Condition		Value (Approx.)
+	-	Signal name	Input/ Output			
1 (GR)	Ground	Battery power supply	Input	Ignition switch OFF	—	Battery voltage
2 (LG)	Ground	Communication signal (METER→ AMP.)	Output	Ignition switch ON	—	<p style="text-align: right;">JSNIA0027GB</p>
3 (GR)	Ground	Communication signal (AMP.→ METER)	Input	Ignition switch ON	—	<p style="text-align: right;">JSNIA0027GB</p>
5 (B)	Ground	Ground	—	Ignition switch ON	—	0 V
6 (P)	Ground	Alternator signal	Input	Ignition switch ON	Charge warning lamp ON	0 V
					Charge warning lamp OFF	Battery voltage
7 (LG)	Ground	Air bag signal	Input	Ignition switch ON	Air bag warning lamp ON	4 V
					Air bag warning lamp OFF	0 V
10 (G)	Ground	Security signal	Input	Ignition switch OFF	Security warning lamp ON	0 V
					Security warning lamp OFF	12 V

A  
B  
C  
D  
E  
F  
G  
H  
I  
J  
K  
L  
M  
O  
P

MWI

# COMBINATION METER

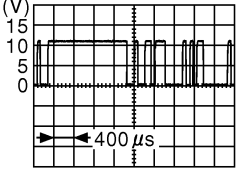
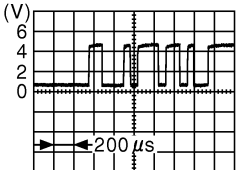
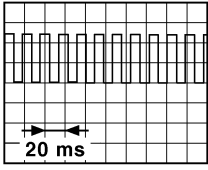
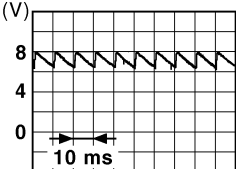

## < ECU DIAGNOSIS INFORMATION >

Terminal No. (Wire color)		Description		Condition		Value (Approx.)
+	-	Signal name	Input/ Output			
15 (B)	Ground	Ground	—	Ignition switch ON	—	0 V
16 (B)	Ground	Meter control switch ground	—	Ignition switch ON	—	0 V
21 (O)	Ground	Ignition signal	Input	Ignition switch ON	—	Battery voltage
22 (B)	Ground	Ground	—	Ignition switch ON	—	0 V
24 (BR)	Ground	Communication signal (LCD→ AMP.)	Output	Ignition switch ON	—	 <small>JSNIA0028GB</small>
25 (Y)	Ground	Communication signal (AMP.→ LCD)	Input	Ignition switch ON	—	 <small>JSNIA0027GB</small>
26 (R)	Ground	Vehicle speed signal (8-pulse)	Input	Ignition switch ON	Speedometer operated [When vehicle speed is ap- prox. 40 km/h (25 MPH)]	<p><b>NOTE:</b> The maximum voltage varies de- pending on the specification (destination unit).</p>  <small>JSNIA0012GB</small>
27 (V)	Ground	Parking brake switch signal	Input	Ignition switch ON	Parking brake is applied	0 V
					Parking brake is released	 <small>JSNIA0007GB</small>
28 (W)	Ground	Brake fluid level switch sig- nal	Input	Ignition switch ON	Brake fluid level is normal.	5 V
					The brake fluid level is low- er than the low level	0 V

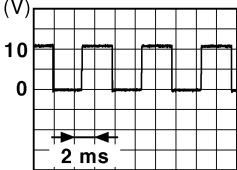

# COMBINATION METER

## < ECU DIAGNOSIS INFORMATION >

Terminal No. (Wire color)		Description		Condition		Value (Approx.)
+	-	Signal name	Input/ Output			
29 (SB)	Ground	Seat belt buckle switch signal (driver side)	Input	Ignition switch ON	When driver seat belt is fastened	12 V
					When driver seat belt is unfastened	0 V
30 (G)	Ground	Seat belt buckle switch signal (passenger side)	Input	Ignition switch ON	<ul style="list-style-type: none"> <li>When getting in the passenger seat</li> <li>When passenger seat belt is fastened</li> </ul>	12 V
					<ul style="list-style-type: none"> <li>When getting in the passenger seat</li> <li>When passenger seat belt is unfastened</li> </ul>	0 V
31 (L)	Ground	Washer level switch signal	Input	Ignition switch ON	Washer level switch ON	0 V
					Washer level switch OFF	5 V
33 (B)	Ground	Illumination control signal	Output	Ignition switch ON	Lighting switch ON, then operate the illumination control switch.	<p><b>NOTE:</b> When brightness level is midway</p>  <p style="text-align: right;"><small>JSNIA0010GB</small></p>
36 (LG)	16 (B)	Select switch signal	Input	Ignition switch ON	When ● is pressed	0 V
					Other than the above	5 V
37 (SB)	16 (B)	Enter switch signal	Input	Ignition switch ON	When □ is pressed	0 V
					Other than the above	5 V
38 (L)	16 (B)	Trip A/B reset switch signal	Input	Ignition switch ON	When trip A/B reset switch is pressed	0 V
					Other than the above	5 V
39 (P)	16 (B)	Illumination control switch signal (-)	Input	Ignition switch ON	When  switch is pressed	0 V
					Other than the above	5 V
40 (O)	16 (B)	Illumination control switch signal (+)	Input	Ignition switch ON	When  switch is pressed	0 V
					Other than the above	5 V

A  
B  
C  
D  
E  
F  
G  
H  
I  
J  
K  
L  
M  
N  
O  
P

MWI

# COMBINATION METER

< ECU DIAGNOSIS INFORMATION >

## Wiring Diagram - METER -

INFOID:000000004348132

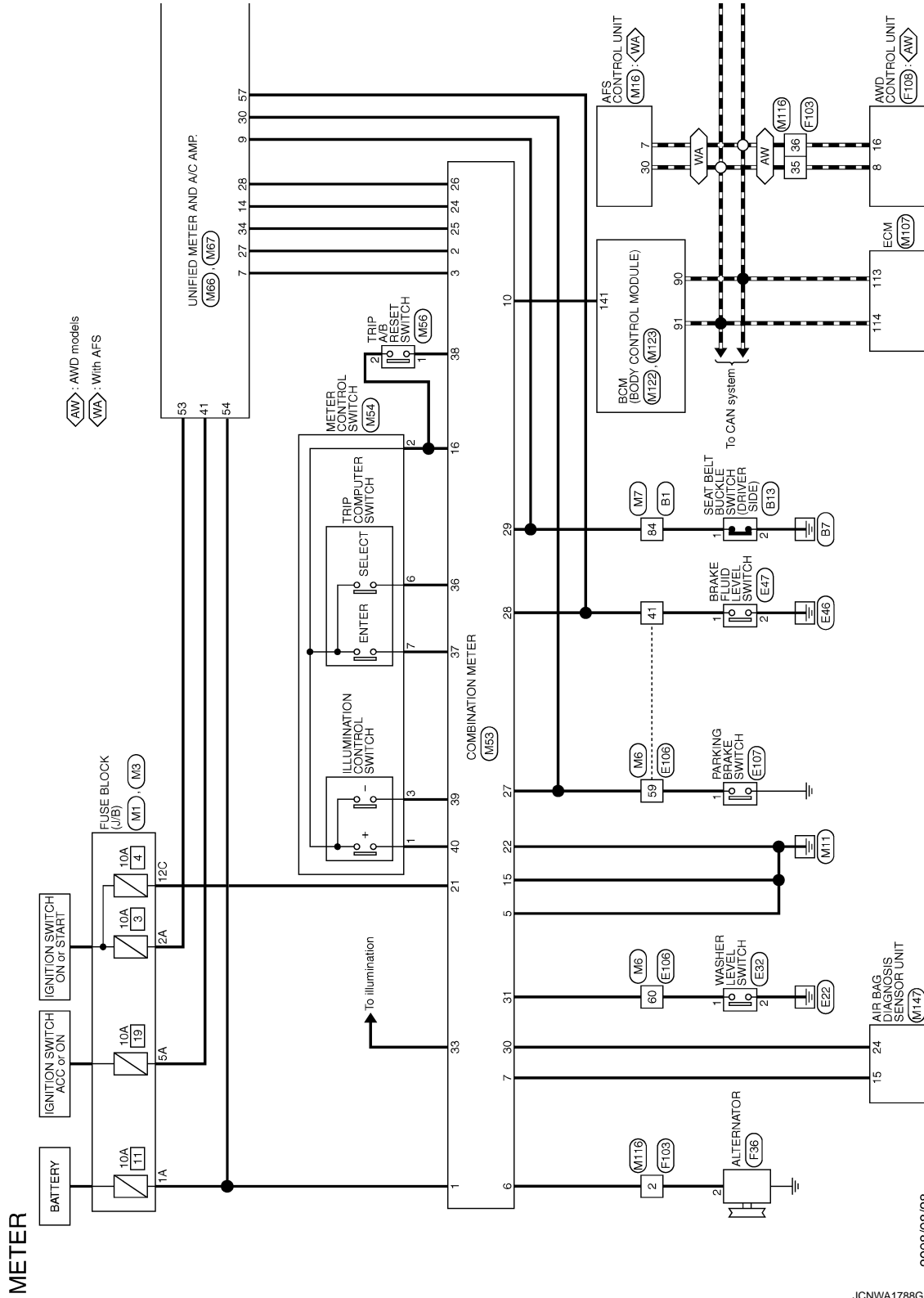

# COMBINATION METER

< ECU DIAGNOSIS INFORMATION >

- : With NAVI
- : Without NAVI
- : With automatic drive positioner
- : Without automatic drive positioner

★ : This connector is not shown in "Harness Layout".

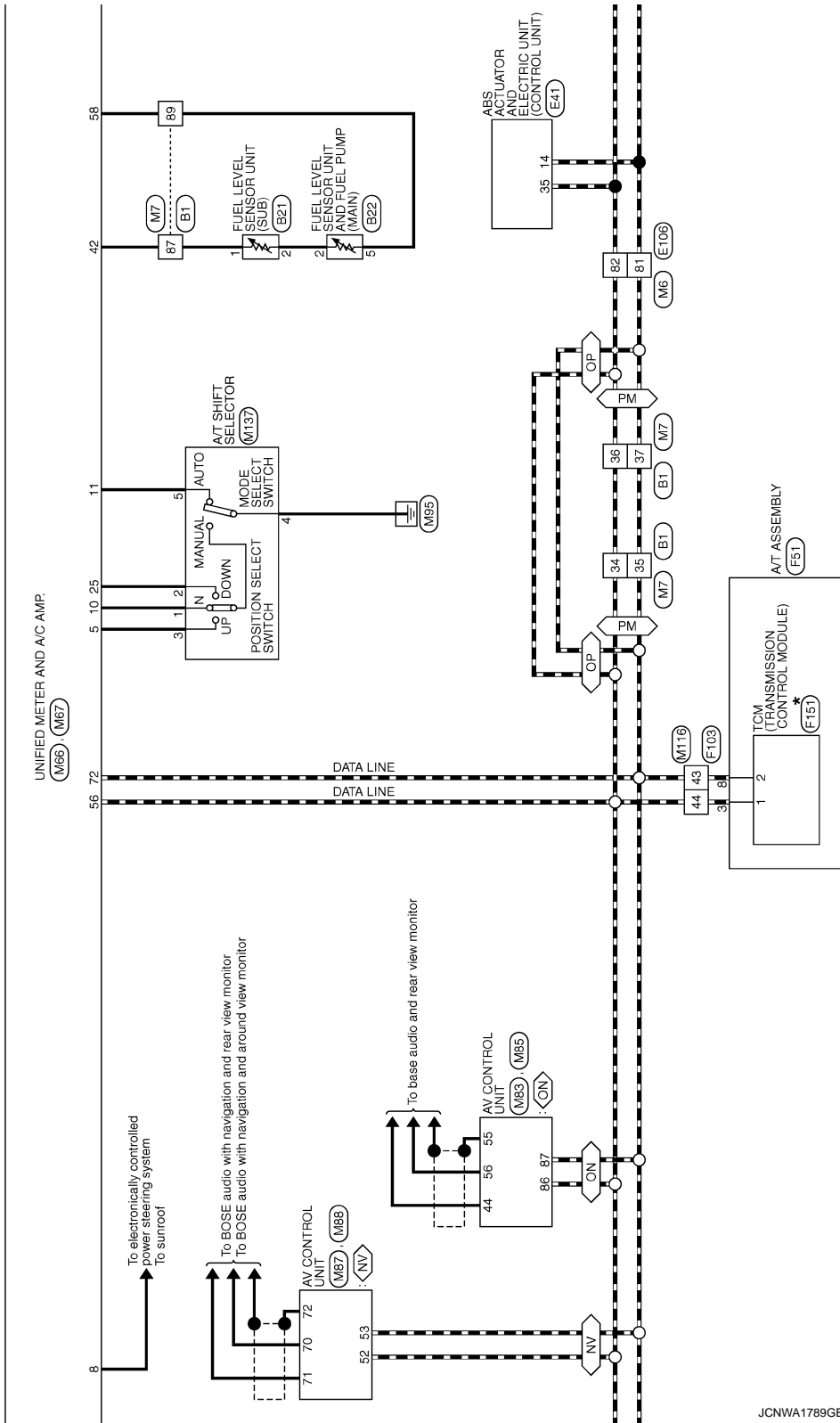

JCNWA1789GB

A  
B  
C  
D  
E  
F  
G  
H  
I  
J  
K  
L  
M  
O  
P



# COMBINATION METER

< ECU DIAGNOSIS INFORMATION >

IC : With ICC

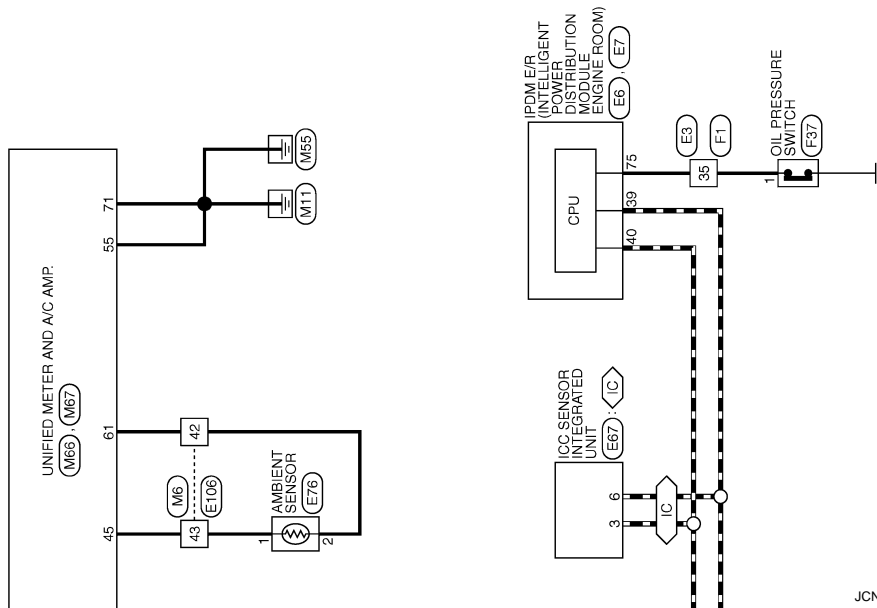

JCNWA1790GB

# COMBINATION METER

< ECU DIAGNOSIS INFORMATION >

## METER

Connector No.	B1
Connector Name	WIRE TO WIRE
Connector Type	TH80FW-CS16-TM4

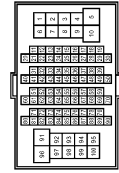

Terminal No.	Color of Wire	Signal Name [Specification]
34	L	-
35	P	-
36	L	-
37	P	-
84	SB	-
87	Y	-
89	B	-

Connector No.	B13
Connector Name	SEAT BELT BUCKLE SWITCH (DRIVER SIDE)
Connector Type	A03FW

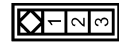

Terminal No.	Color of Wire	Signal Name [Specification]
1	SB	-
2	B	-

Connector No.	B21
Connector Name	FUEL LEVEL SENSOR UNIT (SUB)
Connector Type	EG2FGY-RS



Terminal No.	Color of Wire	Signal Name [Specification]
1	Y	-
2	W	-

Connector No.	B22
Connector Name	FUEL LEVEL SENSOR UNIT AND FUEL PUMP (MAIN)
Connector Type	EG5FGY-RS

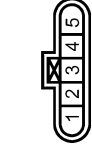

Terminal No.	Color of Wire	Signal Name [Specification]
2	W	-
5	B	-

Connector No.	E3
Connector Name	WIRE TO WIRE
Connector Type	SA438MF-RS10-SJ22



Terminal No.	Color of Wire	Signal Name [Specification]
35	Y	-

Connector No.	E6
Connector Name	IPM E/R INTELLIGENT POWER DISTRIBUTION MODULE ENGINE ROOM
Connector Type	TH80FW-RH

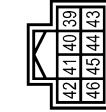

Terminal No.	Color of Wire	Signal Name [Specification]
39	P	-
40	L	-

Connector No.	E7
Connector Name	IPM E/R INTELLIGENT POWER DISTRIBUTION MODULE ENGINE ROOM
Connector Type	TH20FW-CS1F-M4

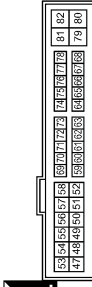

Terminal No.	Color of Wire	Signal Name [Specification]
75	Y	-

Connector No.	E32
Connector Name	WASHER LEVEL SWITCH
Connector Type	Z02FBR



Terminal No.	Color of Wire	Signal Name [Specification]
1	LG	-
2	B	-

A  
B  
C  
D  
E  
F  
G  
H  
I  
J  
K  
L  
M  
MWI  
O  
P

# COMBINATION METER

< ECU DIAGNOSIS INFORMATION >

## METER

Connector No.	E41
Connector Name	ABS ACTUATOR AND ELECTRIC UNIT (CONTROL UNIT)
Connector Type	BAW42F-ALZ4-LH

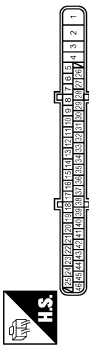

Terminal No.	Color of Wire	Signal Name [Specification]
14	P	CAN-L
35	L	CAN-H

Connector No.	E47
Connector Name	BRAKE FLUID LEVEL SWITCH
Connector Type	YY2ZFGY



Terminal No.	Color of Wire	Signal Name [Specification]
1	W	-
2	B	-

Connector No.	E67
Connector Name	ICC SENSOR INTEGRATED UNIT
Connector Type	RS308F-B-PR



Terminal No.	Color of Wire	Signal Name [Specification]
3	L	CAN-H
6	P	CAN-L

Connector No.	E76
Connector Name	AMBIENT SENSOR
Connector Type	RS32FEB



Terminal No.	Color of Wire	Signal Name [Specification]
1	G	AMBIENT SENSOR SIGNAL
2	P	SENSOR GROUND

Connector No.	E108
Connector Name	WIRE TO WIRE
Connector Type	TH80FW-CS16-TM4

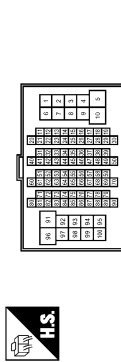

Terminal No.	Color of Wire	Signal Name [Specification]
41	W	-
42	P	-
43	G	-
59	O	-
60	LG	-
81	P	-
82	L	-

Connector No.	E107
Connector Name	PARKING BRAKE SWITCH
Connector Type	TB01FW

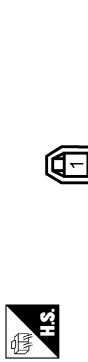

Terminal No.	Color of Wire	Signal Name [Specification]
1	O	-

Connector No.	F1
Connector Name	WIRE TO WIRE
Connector Type	SPA38FB-RS10-SJ22



Terminal No.	Color of Wire	Signal Name [Specification]
35	Y	-

Connector No.	F38
Connector Name	ALTERNATOR
Connector Type	HSSCFB



Terminal No.	Color of Wire	Signal Name [Specification]
2	G	L

JCNWA1792GB

# COMBINATION METER

< ECU DIAGNOSIS INFORMATION >

## METER

Connector No. F37	OIL PRESSURE SWITCH E01FGY-RS-AR	1	Y		
Connector Name					
Connector Type					
Terminal No.	Color of Wire	Signal Name [Specification]			
1	Y				
Connector No. F51	A/T ASSEMBLY RK10FG-DGY	5 4 3 2 1 10 9 8 7 6			
Connector Name					
Connector Type					
Terminal No.	Color of Wire	Signal Name [Specification]			
3	L				
8	P				
Connector No. F103	WIRE TO WIRE TK38FW-NS10	1 2 3 4 5 6 7 8 9 10 11 12 13 14 15 16			
Connector Name					
Connector Type					
Terminal No.	Color of Wire	Signal Name [Specification]			
2	G				
35	L				
36	P				
43	P				
44	L				
Connector No. F108	AMD CONTROL UNIT TH16FW-NH	1 2 3 4 5 6 7 8 9 10 11 12 13 14 15 16			
Connector Name					
Connector Type					
Terminal No.	Color of Wire	Signal Name [Specification]			
8	L	CAN-H			
16	P	CAN-L			
Connector No. M3	FUSE BLOCK (J/B) NS12FW-CS	5C 4C 12C 11C 10C 9C 8C 7C 6C			
Connector Name					
Connector Type					
Terminal No.	Color of Wire	Signal Name [Specification]			
12C	O				
Connector No. M6	WIRE TO WIRE TH68MW-CS16-TM4	1 2 3 4 5 6 7 8 9 10 11 12 13 14 15 16			
Connector Name					
Connector Type					
Terminal No.	Color of Wire	Signal Name [Specification]			
41	W				
42	BR				
43	P				
59	V				
60	L				
81	P				
82	L				
Connector No. M1	FUSE BLOCK (J/B) NS06FW-M2	3A 2A 1A 8A 7A 6A 5A 4A			
Connector Name					
Connector Type					
Terminal No.	Color of Wire	Signal Name [Specification]			
1A	GR				
2A	G				
5A	V				
Connector No. F151	TOM (TRANSMISSION CONTROL MODULE) SP10FBGY	1 0 9 8 7 6 5 4 3 2 1			
Connector Name					
Connector Type					
Terminal No.	Color of Wire	Signal Name [Specification]			
1	BR	CAN-H			
2	L/Y	CAN-L			

JCNWA1793GB

A  
B  
C  
D  
E  
F  
G  
H  
I  
J  
K  
L  
M  
MWI  
O  
P

# COMBINATION METER

< ECU DIAGNOSIS INFORMATION >

## METER

Connector No.	M7
Connector Name	WIRE TO WIRE
Connector Type	TH80MW-CS16-TM4



Terminal No.	Color of Wire	Signal Name [Specification]
34	L	-
35	P	-
36	L	-
37	P	-
84	SB	-
87	Y	-
89	BR	-

Connector No.	M16
Connector Name	AFS CONTROL UNIT
Connector Type	TH40FW-NH



Terminal No.	Color of Wire	Signal Name [Specification]
7	P	CAN-L
30	L	CAN-H

Connector No.	M83
Connector Name	COMBINATION METER
Connector Type	TH40FW-NH



Terminal No.	Color of Wire	Signal Name [Specification]
1	GR	BAT
2	LG	COMM (METER->AMP.)
3	GR	COMM (AMP->METER)
5	B	GND
6	P	ALTERNATOR
7	LG	AIR BAG
10	G	SECURITY
15	B	GND
16	B	METER CONTROL SW GND
21	O	IGN
22	B	GND

24	BR	COMM (LCD->AMP.)
25	Y	COMM (AMP->LCD)
26	R	VEHICLE SPEED (8-PULSE)
27	V	PARKING BRAKE SW
28	W	BRAKE FLUID LEVEL SW
29	SB	SEAT BELT BUCKLE SW (DRIVER SIDE)
30	G	SEAT BELT
31	L	WASHER LEVEL SW
33	B	ILLUMINATION CONTROL
36	LG	SELECT SW
37	SB	ENTER SW
38	L	TRIP A/B RESET SW
39	P	ILLUMINATION CONTROL SW (-)
40	O	ILLUMINATION CONTROL SW (+)

Connector No.	M84
Connector Name	METER CONTROL SWITCH
Connector Type	TH12MW-NH

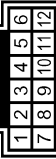

Terminal No.	Color of Wire	Signal Name [Specification]
1	O	-
2	B	-
3	P	-
6	LG	-
7	SB	-

Connector No.	M86
Connector Name	TRIP A/B RESET SWITCH
Connector Type	TK02MW



Terminal No.	Color of Wire	Signal Name [Specification]
1	L	-
2	B	-

Connector No.	M86
Connector Name	UNIFIED METER AND A/C AMP.
Connector Type	TH40FW-NH



Terminal No.	Color of Wire	Signal Name [Specification]
5	L	SHIFT UP
7	GR	COMMUNICATION SIGNAL (AMP->METER)
8	L	VEHICLE SPEED (2-PULSE)
9	SB	SEAT BELT BUCKLE SWITCH (DRIVER SIDE)
10	W	MANUAL MODE
11	G	NOT MANUAL MODE
14	BR	COMMUNICATION SIGNAL (LCD->AMP.)
25	V	SHIFT DOWN
27	LG	COMMUNICATION SIGNAL (METER->AMP.)
28	R	VEHICLE SPEED (8-PULSE)
30	V	PARKING BRAKE SWITCH

34	Y	COMMUNICATION SIGNAL (AMP->LCD)
----	---	---------------------------------

JCNWA1794GB



# COMBINATION METER

< ECU DIAGNOSIS INFORMATION >

## METER

Connector No.	M67
Connector Name	UNIFIED METER AND A/C AMP.
Connector Type	TH22FW-NH

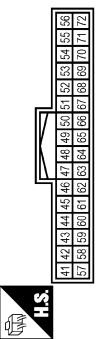

Terminal No.	Color of Wire	Signal Name [Specification]
41	V	ACC POWER SUPPLY
42	Y	FUEL LEVEL SENSOR SIGNAL
45	P	AMBIENT SENSOR SIGNAL
53	G	IGNITION POWER SUPPLY
54	Y	BATTERY POWER SUPPLY
55	B	GROUND
56	L	CAN-H
57	W	BRAKE FLUID LEVEL SWITCH
58	BR	FUEL LEVEL SENSOR GROUND
61	BR	AMBIENT SENSOR GROUND
71	B	GROUND

72	P	CAN-L
----	---	-------

Connector No.	M83
Connector Name	AV CONTROL UNIT (WITHOUT NAVI)
Connector Type	TH24FW-NH

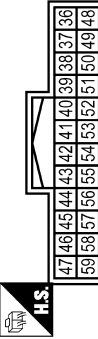

Terminal No.	Color of Wire	Signal Name [Specification]
44	BR	COMM (DISP->CONT)
55	SHIELD	SHIELD
56	Y	COMM (CONT->DISP)

Connector No.	M85
Connector Name	AV CONTROL UNIT (WITHOUT NAVI)
Connector Type	TH32FW-NH

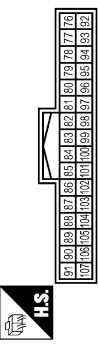

Terminal No.	Color of Wire	Signal Name [Specification]
86	L	CAN-H
87	P	CAN-L

Connector No.	M87
Connector Name	AV CONTROL UNIT (WITH NAVI)
Connector Type	TH40FW-NH

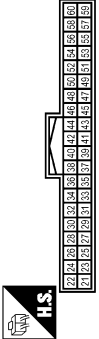

Terminal No.	Color of Wire	Signal Name [Specification]
52	L	CAN-H
53	P	CAN-L

Connector No.	M88
Connector Name	AV CONTROL UNIT (WITH NAVI)
Connector Type	TH12FW-NH



Terminal No.	Color of Wire	Signal Name [Specification]
70	BR	COMM (CONT->DISP)
71	Y	COMM (DISP->CONT)
72	SHIELD	SHIELD

Connector No.	M107
Connector Name	ECM
Connector Type	PH24FGY-R2S-R-LH-Z



Terminal No.	Color of Wire	Signal Name [Specification]
113	P	VEHCAN-LI
114	L	VEHCAN-HI

Connector No.	M116
Connector Name	WIRE TO WIRE
Connector Type	TK38MW-NS10

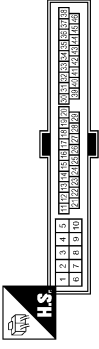

Terminal No.	Color of Wire	Signal Name [Specification]
2	P	-
35	L	-
36	P	-
43	P	-
44	L	-

JCNWA1795GB



A  
B  
C  
D  
E  
F  
G  
H  
I  
J  
K  
L  
M  
MWI  
O  
P

# COMBINATION METER

## < ECU DIAGNOSIS INFORMATION >

### METER

Connector No.	M147
Connector Name	AIR BAG DIAGNOSIS SENSOR UNIT
Connector Type	TK2BFY-EX-SC

Terminal No.	Color of Wire	Signal Name [Specification]
15	LG	AIR BAG W/L
24	G	SEAT BELT

Connector No.	M137
Connector Name	A/T SHIFT SELECTOR
Connector Type	TH12FW-NH

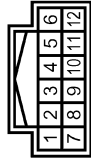

Terminal No.	Color of Wire	Signal Name [Specification]
1	W	-
2	V	-
3	L	-
4	B	-
5	G	-

Connector No.	M123
Connector Name	BCM (BODY CONTROL MODULE)
Connector Type	TH4BFG-NH

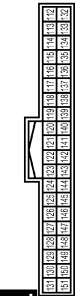
Terminal No.	Color of Wire	Signal Name [Specification]
141	G	SECURITY INDICATOR OUTPUT

Connector No.	M122
Connector Name	BCM (BODY CONTROL MODULE)
Connector Type	TH4BFB-NH

Terminal No.	Color of Wire	Signal Name [Specification]
90	P	CAN-L
91	L	CAN-H

JCNWA1796GB

## Fail-Safe

INFOID:000000004348133

### FAIL-SAFE

Combination meter performs fail-safe operation when unified meter and A/C amp. communication is malfunction.

Solution for communication error between the unified meter and A/C amp. and combination meter.

# COMBINATION METER

## < ECU DIAGNOSIS INFORMATION >

Function		Specifications	
Speedometer		Reset to zero by suspending communication.	A
Tachometer			B
Fuel gauge			C
Water temperature gauge			D
Illumination control		When suspending communication, change to nighttime mode.	E
Information display		The display turns off by suspending communication.	F
Buzzer		The buzzer turns off by suspending communication.	G
Warning lamp/indicator lamp	ABS warning lamp	The lamp turns on by suspending communication.	H
	VDC OFF indicator lamp		I
	SLIP indicator lamp		J
	Brake warning lamp		K
	CRUISE warning lamp		L
	IBA OFF indicator lamp		M
	High beam indicator	The lamp turns off by suspending communication.	N
	Turn signal indicator lamp		O
	Tail lamp indicator lamp		P
	Oil pressure warning lamp		
	Malfunction indicator lamp		
	A/T CHECK warning lamp		
	AWD warning lamp		
	Low tire pressure warning lamp		
	Key warning lamp		
	AFS OFF indicator lamp		
Lane departure warning lamp			
LDP ON indicator lamp			
Master warning lamp			

### DTC Index

INFOID:000000004348134

Refer to [MWI-100. "DTC Index"](#).

MWI

# UNIFIED METER AND A/C AMP.

< ECU DIAGNOSIS INFORMATION >

## UNIFIED METER AND A/C AMP.

### Reference Value

INFOID:000000004348135

### VALUES ON THE DIAGNOSIS TOOL

#### CONSULT-III MONITOR ITEM

Monitor Item	Condition		Value/Status
SPEED METER [km/h] or [mph]	Ignition switch ON	While driving	Equivalent to speedometer reading <b>NOTE:</b> 655.35 is displayed when the malfunction signal is received
SPEED OUTPUT [km/h] or [mph]	Ignition switch ON	While driving	Equivalent to speedometer reading <b>NOTE:</b> 655.35 is displayed when the malfunction signal is received
ODO OUTPUT [km/h] or [mph]	Ignition switch ON	—	Equivalent to odometer reading in combination meter
TACHO METER [rpm]	Ignition switch ON	While driving	Equivalent to tachometer reading <b>NOTE:</b> 8191.875 is displayed when the malfunction signal is received
FUEL METER [L]	Ignition switch ON	—	Values according to fuel level
W TEMP METER [°C] or [°F]	Ignition switch ON	—	Values according to engine coolant temperature <b>NOTE:</b> 215 is displayed when the malfunction signal is input
ABS W/L	Ignition switch ON	ABS warning lamp ON	On
		ABS warning lamp OFF	Off
VDC/TCS IND	Ignition switch ON	VDC OFF indicator lamp ON	On
		VDC OFF indicator lamp OFF	Off
SLIP IND	Ignition switch ON	SLIP indicator lamp ON	On
		SLIP indicator lamp OFF	Off
BRAKE W/L	Ignition switch ON	Brake warning lamp ON	On
		Brake warning lamp OFF	Off
DOOR W/L	Ignition switch ON	Door warning displayed	On
		Door warning not displayed	Off
HI-BEAM IND	Ignition switch ON	Hi-beam indicator lamp ON	On
		Hi-beam indicator lamp OFF	Off
TURN IND	Ignition switch ON	Turn indicator lamp ON	On
		Turn indicator lamp OFF	Off
FR FOG IND	Ignition switch ON	<b>NOTE:</b> This item is displayed, but cannot be monitored.	Off
RR FOG IND	Ignition switch ON	<b>NOTE:</b> This item is displayed, but cannot be monitored.	Off
LIGHT IND	Ignition switch ON	Tail lamp indicator lamp ON	On
		Tail lamp indicator lamp OFF	Off
OIL W/L	Ignition switch ON	Oil pressure warning lamp ON	On
		Oil pressure warning lamp OFF	Off

## UNIFIED METER AND A/C AMP.

### < ECU DIAGNOSIS INFORMATION >

Monitor Item	Condition		Value/Status	
MIL	Ignition switch ON	Malfunction warning lamp ON	On	A
		Malfunction warning lamp OFF	Off	
GLOW IND	Ignition switch ON	<b>NOTE:</b> This item is displayed, but cannot be monitored.	Off	B
C-ENG2 W/L	Ignition switch ON	<b>NOTE:</b> This item is displayed, but cannot be monitored.	Off	C
CRUISE IND	Ignition switch ON	CRUISE indicator displayed	On	D
		CRUISE indicator not displayed	Off	
SET IND	Ignition switch ON	SET indicator lamp ON	On	E
		SET indicator lamp OFF	Off	
CRUISE W/L	Ignition switch ON	CRUISE warning lamp ON	On	F
		CRUISE warning lamp OFF	Off	
BA W/L	Ignition switch ON	IBA OFF indicator lamp ON	On	G
		IBA OFF indicator lamp OFF	Off	
ATC/T-AMT W/L	Ignition switch ON	A/T check warning lamp ON	On	H
		A/T check warning lamp OFF	Off	
4WD W/L	Ignition switch ON	AWD warning lamp ON	On	I
		AWD warning lamp OFF	Off	
4WD LOCK IND	Ignition switch ON	<b>NOTE:</b> This item is displayed, but cannot be monitored.	Off	J
FUEL W/L	Ignition switch ON	Low-fuel warning lamp displayed	On	K
		Low-fuel warning lamp not displayed	Off	
WASHER W/L	Ignition switch ON	Washer warning displayed	On	L
		Washer warning not displayed	Off	
AIR PRES W/L	Ignition switch ON	Low tire pressure warning lamp ON	On	M
		Low tire pressure warning lamp OFF	Off	
KEY G/Y W/L	Ignition switch ON	Key warning lamp ON	On	MWI
		Key warning lamp OFF	Off	
AFS OFF IND	Ignition switch ON	AFS OFF indicator lamp ON	On	O
		AFS OFF indicator lamp OFF	Off	
4WAS/RAS W/L	Ignition switch ON	<b>NOTE:</b> This item is displayed, but cannot be monitored.	Off	P
DDS W/L	Ignition switch ON	<b>NOTE:</b> This item is displayed, but cannot be monitored.	Off	
LANE W/L	Ignition switch ON	Lane departure warning lamp ON	On	
		Lane departure warning lamp OFF	Off	
LDP IND	Ignition switch ON	LDP ON indicator lamp ON	On	
		LDP ON indicator lamp OFF	Off	
DCA IND	Ignition switch ON	DCA switch indicator displayed	On	
		DCA switch indicator not displayed	Off	

## UNIFIED METER AND A/C AMP.

### < ECU DIAGNOSIS INFORMATION >

Monitor Item	Condition		Value/Status
LCD	Ignition switch ON	Engine start information display	B&P I
	Ignition switch ACC	Engine start information display	B&P N
	Ignition switch LOCK	Key ID warning display	ID NG
	Ignition switch LOCK	Steering lock information display	ROTAT
	Ignition switch LOCK	P position warning display	SFT P
	Ignition switch LOCK	Intelligent Key insert information display	INSRT
	Ignition switch LOCK	Intelligent Key low battery warning display	BATT
	Ignition switch ON	Take away warning display	NO KY
	Ignition switch LOCK	Key warning display	OUTKY
	Ignition switch ON	ACC warning display	LK WN
ACC TARGET	Ignition switch ON	Vehicle ahead detection indicator displayed	On
		Vehicle ahead detection indicator not displayed	Off
ACC DISTANCE	Ignition switch ON	When following distance set to "LONG"	LONG
		When following distance set to "MIDDLE"	MID
		When following distance set to "SHORT"	SHORT
		Set distance indicator not displayed	Off
ACC OWN VHL	Ignition switch ON	Own vehicle indicator displayed	On
		Own vehicle indicator not displayed	Off
ACC SET SPEED	Ignition switch ON	Set vehicle speed indicator not displayed	Off
		Set vehicle speed indicator displayed	Indicates the set vehicle speed
ACC UNIT	Ignition switch ON	Set vehicle speed indicator unit display ON	On
		Set vehicle speed indicator unit display OFF	Off
SHIFT IND	Ignition switch ON	Shift position indicator P display	P
		Shift position indicator R display	R
		Shift position indicator N display	N
		Shift position indicator D display	D
		Shift position indicator DS display	L
		Shift position indicator M1 display	M1
		Shift position indicator M2 display	M2
		Shift position indicator M3 display	M3
		Shift position indicator M4 display	M4
Shift position indicator M5 display	M5		
O/D OFF SW	Ignition switch ON	<b>NOTE:</b> This item is displayed, but cannot be monitored.	Off
AT S MODE SW	Ignition switch ON	Snow mode switch ON	On
		Snow mode switch OFF	Off

## UNIFIED METER AND A/C AMP.

### < ECU DIAGNOSIS INFORMATION >

Monitor Item	Condition		Value/Status
AT P MODE SW	Ignition switch ON	<b>NOTE:</b> This item is displayed, but cannot be monitored.	Off
M RANGE SW	Ignition switch ON	Selector lever manual mode position	On
		Other than the above	Off
NM RANGE SW	Ignition switch ON	Selector lever manual mode position	Off
		Other than the above	On
AT SFT UP SW	Ignition switch ON	Selector lever + position	On
		Other than the above	Off
AT SFT DWN SW	Ignition switch ON	Selector lever – position	On
		Other than the above	Off
ST SFT UP SW	Ignition switch ON	<b>NOTE:</b> This item is displayed, but cannot be monitored.	Off
ST SFT DWN SW	Ignition switch ON	<b>NOTE:</b> This item is displayed, but cannot be monitored.	Off
COMP F/B SIG	Ignition switch ON	A/C compressor activation condition	On
		A/C compressor deactivation condition	Off
4WD LOCK SW	Ignition switch ON	<b>NOTE:</b> This item is displayed, but cannot be monitored.	Off
PKB SW	Ignition switch ON	Parking brake switch ON	On
		Parking brake switch OFF	Off
BUCKLE SW	Ignition switch ON	Driver seat belt not fastened	On
		Driver seat belt fastened	Off
BRAKE OIL SW	Ignition switch ON	Brake fluid level switch ON	On
		Brake fluid level switch OFF	Off
DISTANCE [km]	Ignition switch ON	—	Possible driving distance calculated by unified meter and A/C amp.
OUTSIDE TEMP [°C] or [°F]	Ignition switch ON	—	Equivalent to ambient temperature <b>NOTE:</b> This may not match the indicated value on the information display.
FUEL LOW SIG	Ignition switch ON	Low-fuel warning signal output	On
		Low-fuel warning signal not output	Off
BUZZER	Ignition switch ON	Buzzer ON	On
		Buzzer OFF	Off

**NOTE:**

Some items are not available according to vehicle specification.

### TERMINAL LAYOUT

A  
B  
C  
D  
E  
F  
G  
H  
I  
J  
K  
L  
M  
MWI  
O  
P

# UNIFIED METER AND A/C AMP.

< ECU DIAGNOSIS INFORMATION >

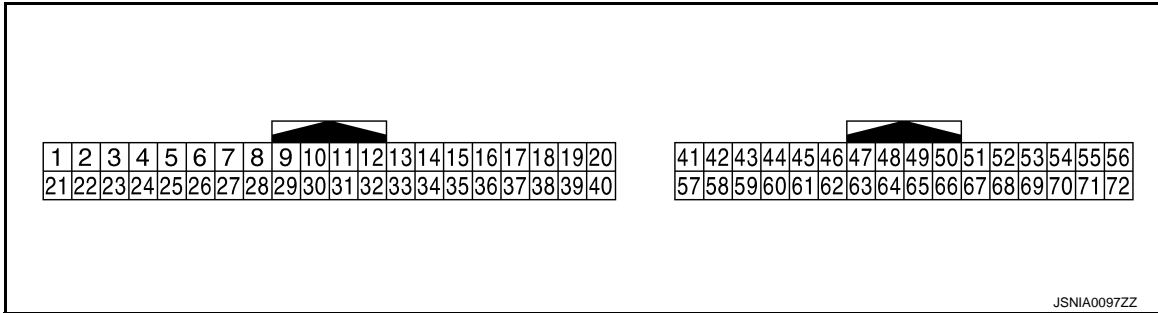

JSNIA0097ZZ

## PHYSICAL VALUES

Terminal No. (Wire color)		Description		Condition		Value (Approx.)
+	-	Signal name	Input/ Output			
5 (L)	Ground	Manual mode shift up signal	Input	Ignition switch ON	Selector lever UP operation	0 V
					Other than the above	12 V
7 (GR)	Ground	Communication signal (AMP. → METER)	Output	Ignition switch ON	—	<p style="text-align: right; font-size: small;">SKIA3362E</p>
8 (L)	Ground	Vehicle speed signal (2-pulse)	Output	Ignition switch ON	Speedometer operated [When vehicle speed is approx. 40 km/h (25 MPH)]	<p><b>NOTE:</b> The maximum voltage varies depending on the specification (destination unit).</p> <p style="text-align: right; font-size: small;">JSNIA0015GB</p>
9 (SB)	Ground	Seat belt buckle switch signal (driver side)	Input	Ignition switch ON	When seat belt is fastened	12 V
					When seat belt is not fastened	0 V
10 (W)	Ground	Manual mode signal	Input	Ignition switch ON	Selector lever DS position	0 V
					Other than the above	12 V
11 (G)	Ground	Not manual mode signal	Input	Ignition switch ON	Selector lever DS position	12 V
					Other than the above	0 V
14 (BR)	Ground	Communication signal (LCD → AMP.)	Input	Ignition switch ON	—	<p style="text-align: right; font-size: small;">JSNIA0028GB</p>



# UNIFIED METER AND A/C AMP.

## < ECU DIAGNOSIS INFORMATION >

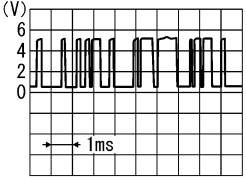
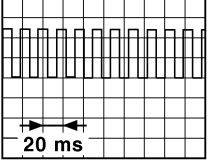
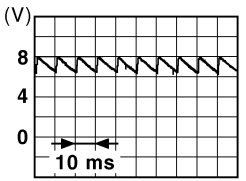
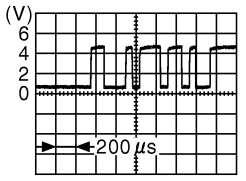
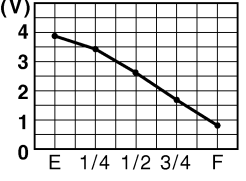
Terminal No. (Wire color)		Description		Condition		Value (Approx.)
+	-	Signal name	Input/ Output			
25 (V)	Ground	Manual mode shift down signal	Input	Ignition switch ON	Selector lever down opera- tion	0 V
					Other than the above	12 V
27 (LG)	Ground	Communication signal (METER → AMP.)	Input	Ignition switch ON	—	 <p style="text-align: right; font-size: small;">SKIA3361E</p>
28 (R)	Ground	Vehicle speed signal (8-pulse)	Output	Ignition switch ON	Speedometer operated [When vehicle speed is ap- prox. 40 km/h (25 MPH)]	<p><b>NOTE:</b> The maximum voltage varies de- pending on the specification (destination unit).</p>  <p style="text-align: right; font-size: small;">JSNIA0012GB</p>
30 (V)	Ground	Parking brake switch signal	Input	Ignition switch ON	Parking brake is applied	0 V
					Parking brake is released	 <p style="text-align: right; font-size: small;">JSNIA0007GB</p>
34 (Y)	Ground	Communication signal (AMP. → LCD)	Output	Ignition switch ON	—	 <p style="text-align: right; font-size: small;">JSNIA0027GB</p>
41 (V)	Ground	ACC power supply	Input	Ignition switch ACC	—	Battery voltage
42 (Y)	Ground	Fuel level sensor signal	Input	Ignition switch ON	—	 <p style="text-align: right; font-size: small;">JSNIA0013GB</p>

A  
B  
C  
D  
E  
F  
G  
H  
I  
J  
K  
L  
M  
O  
P

MWI

# UNIFIED METER AND A/C AMP.

## < ECU DIAGNOSIS INFORMATION >

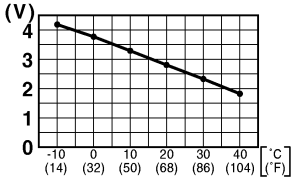
Terminal No. (Wire color)		Description		Condition		Value (Approx.)
+	-	Signal name	Input/ Output			
45 (P)	Ground	Ambient sensor signal	Input	—	—	 <p style="text-align: right; font-size: small;">JSNIA0014GB</p>
53 (G)	Ground	Ignition signal	Input	Ignition switch ON	—	Battery voltage
54 (Y)	Ground	Battery power supply	Input	Ignition switch OFF	—	Battery voltage
55 (B)	Ground	Ground	—	Ignition switch ON	—	0 V
56 (L)	Ground	CAN-H	—	—	—	—
57 (W)	Ground	Brake fluid level switch signal	Input	Ignition switch ON	Brake fluid level is normal.	5 V
					The brake fluid level is lower than the low level	0 V
58 (BR)	Ground	Fuel level sensor signal ground	—	Ignition switch ON	—	0 V
61 (BR)	Ground	Ambient sensor signal ground	—	Ignition switch ON	—	0 V
71 (B)	Ground	Ground	—	Ignition switch ON	—	0 V
72 (P)	Ground	CAN-L	—	—	—	—

# UNIFIED METER AND A/C AMP.

< ECU DIAGNOSIS INFORMATION >

## Wiring Diagram - METER -

INFOID:000000004932860

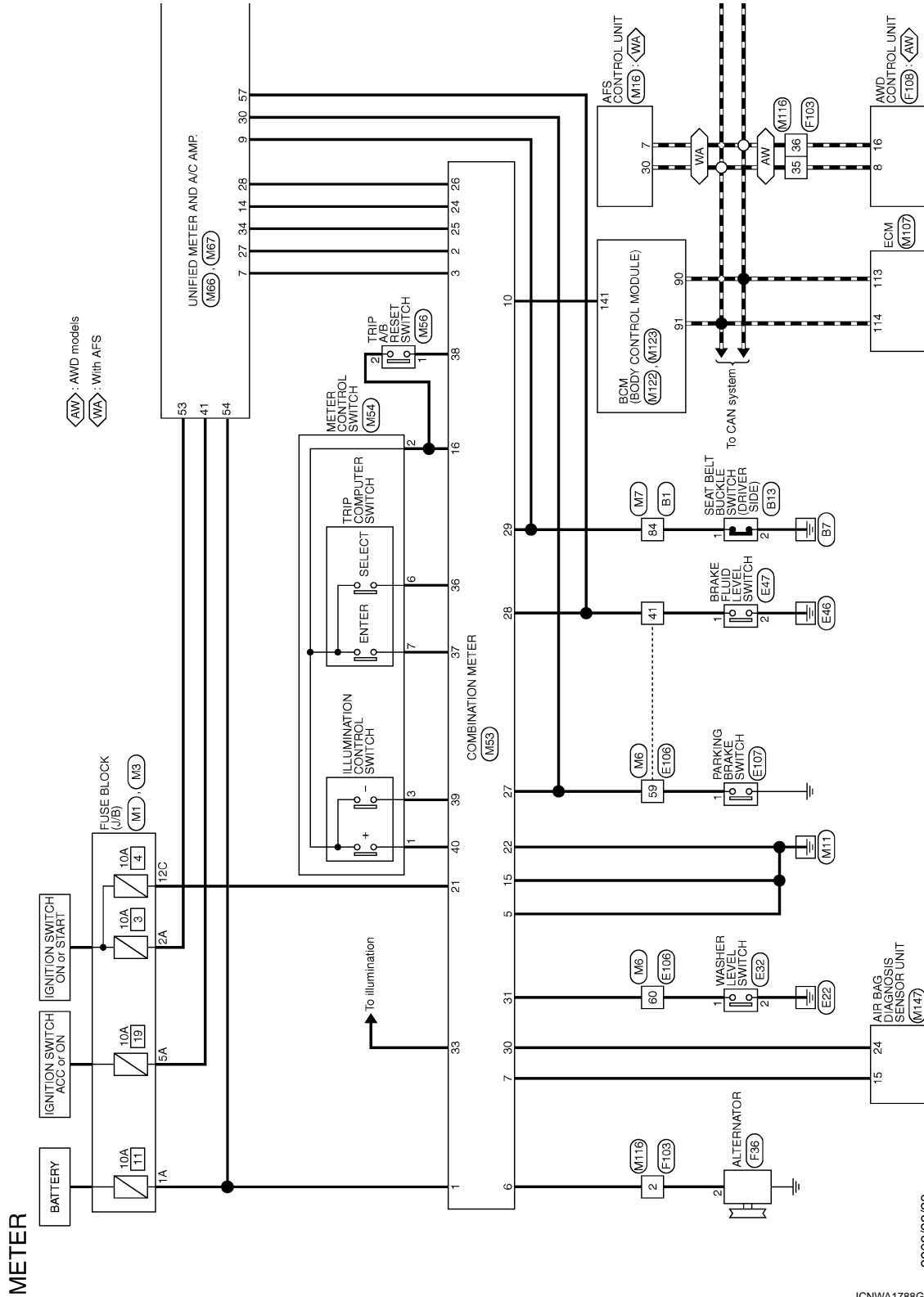

A  
B  
C  
D  
E  
F  
G  
H  
I  
J  
K  
L  
M  
N  
O  
P

MWI

# UNIFIED METER AND A/C AMP.

< ECU DIAGNOSIS INFORMATION >

◊NV◊ : With NAVI  
 ◊CN◊ : Without NAVI  
 ◊PM◊ : With automatic drive positioner  
 ◊OP◊ : Without automatic drive positioner

\*: This connector is not shown in "Harness Layout".

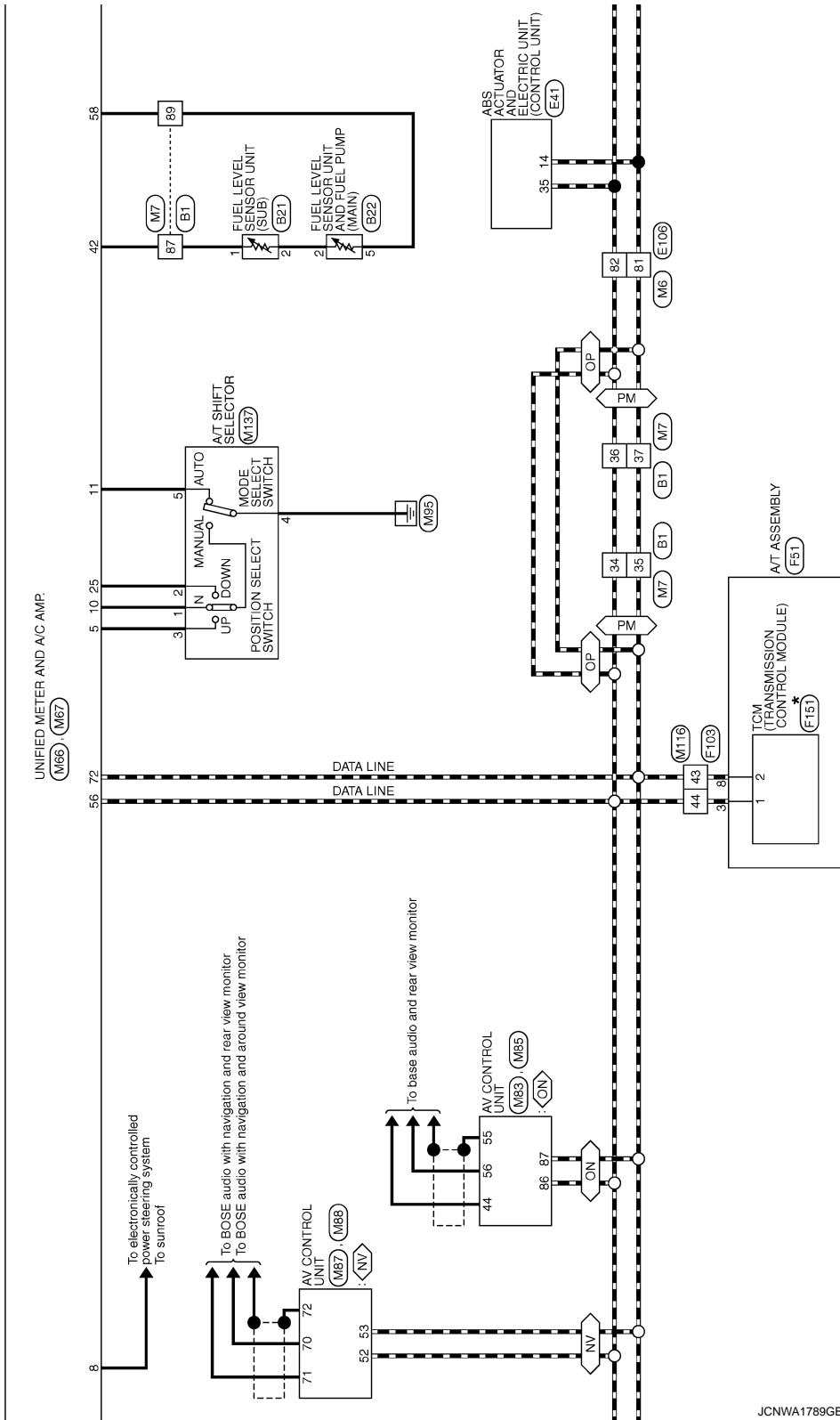

JCNWA1789GB

# UNIFIED METER AND A/C AMP.

< ECU DIAGNOSIS INFORMATION >

IC: With ICC

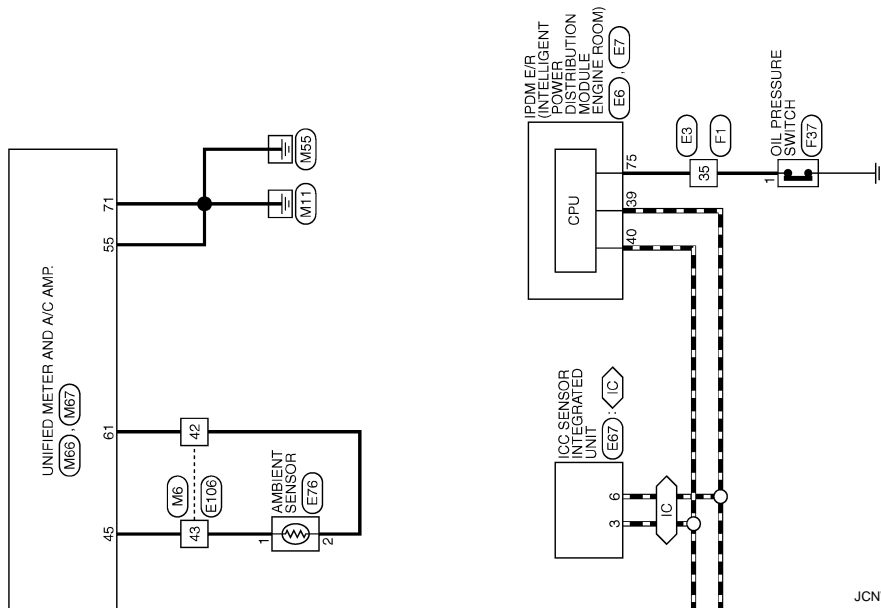

JCNWA1790GB









A  
B  
C  
D  
E  
F  
G  
H  
I  
J  
K  
L  
M  
N  
O  
P

MWI

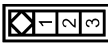
# UNIFIED METER AND A/C AMP.

## < ECU DIAGNOSIS INFORMATION >

### METER







Connector No. B1	WIRE TO WIRE TH8DFW-GS16-TM4		Terminal No.	Color of Wire	Signal Name [Specification]
Connector Name			34	L	
Connector Type			35	P	
			36	L	
			37	P	
			84	SB	
			87	Y	
			89	B	
Connector No. B2	FUEL LEVEL SENSOR UNIT AND FUEL PUMP (MAIN) EB5FGY-RS		Terminal No.	Color of Wire	Signal Name [Specification]
Connector Name			2	W	
Connector Type			5	B	
Connector No. B21	FUEL LEVEL SENSOR UNIT (SUB) EQ2FGY-RS		Terminal No.	Color of Wire	Signal Name [Specification]
Connector Name			1	Y	
Connector Type			2	W	
Connector No. B13	SEAT BELT BUCKLE SWITCH (DRIVER SIDE) A03FW		Terminal No.	Color of Wire	Signal Name [Specification]
Connector Name			1	SB	
Connector Type			2	B	
Connector No. E3	WIRE TO WIRE SAA3SMB-RS10-SJ22		Terminal No.	Color of Wire	Signal Name [Specification]
Connector Name			35	Y	
Connector Type					
Connector No. E32	WASHER LEVEL SWITCH Z02FBR		Terminal No.	Color of Wire	Signal Name [Specification]
Connector Name			1	LG	
Connector Type			2	B	
Connector No. E7	FROM E/R INTELLIGENT POWER DISTRIBUTION MODULE (ENGINE ROOM) T112FPW-CS12-M4		Terminal No.	Color of Wire	Signal Name [Specification]
Connector Name			75	Y	
Connector Type					
Connector No. E6	FROM E/R INTELLIGENT POWER DISTRIBUTION MODULE (ENGINE ROOM) TH8DFW-N1		Terminal No.	Color of Wire	Signal Name [Specification]
Connector Name			39	P	
Connector Type			40	L	
Connector No. E7	FROM E/R INTELLIGENT POWER DISTRIBUTION MODULE (ENGINE ROOM) T112FPW-CS12-M4		Terminal No.	Color of Wire	Signal Name [Specification]
Connector Name					
Connector Type					

JCNWA1791GB

# UNIFIED METER AND A/C AMP.

## < ECU DIAGNOSIS INFORMATION >

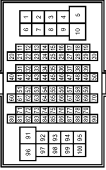
### METER

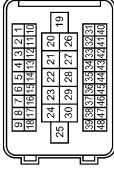
Connector No. E41	ABS ACTUATOR AND ELECTRIC UNIT (CONTROL UNIT)	EA42FB-ATZ4-LH		Terminal No. 14	Color of Wire P	Signal Name [Specification] CAN-L
Connector No. E47	BRAKE FLUID LEVEL SWITCH	TY22FGY		Terminal No. 1	Color of Wire W	Signal Name [Specification] -
Connector No. E67	ICC SENSOR INTEGRATED UNIT	RS06FB-PR		Terminal No. 3	Color of Wire L	Signal Name [Specification] CAN-H
Connector No. E76	AMBIENT SENSOR	RS07FB		Terminal No. 1	Color of Wire G	Signal Name [Specification] AMBIENT SENSOR SIGNAL
Connector No. E108	WIRE TO WIRE	TH09FW-GS16-TM4		Terminal No. 42	Color of Wire P	Signal Name [Specification] -
Connector No. E107	PARKING BRAKE SWITCH	TB01FW		Terminal No. 1	Color of Wire O	Signal Name [Specification] -
Connector No. F36	ALTERNATOR	HS07FB		Terminal No. 2	Color of Wire G	Signal Name [Specification] -
Connector No. FI	WIRE TO WIRE	SA436FB-RS-U-SJ22		Terminal No. 35	Color of Wire Y	Signal Name [Specification] -

JCNWA1792GB

A  
B  
C  
D  
E  
F  
G  
H  
I  
J  
K  
L  
M  
MWI  
O  
P

# UNIFIED METER AND A/C AMP.

< ECU DIAGNOSIS INFORMATION >

**METER**

Connector No.	F37
Connector Name	OIL PRESSURE SWITCH
Connector Type	E01FGY-RS-AR



Terminal No.	Color of Wire	Signal Name [Specification]
1	Y	-

Connector No.	F51
Connector Name	A/T ASSEMBLY
Connector Type	BK10FG-DGY



Terminal No.	Color of Wire	Signal Name [Specification]
3	L	-
8	P	-

Connector No.	F103
Connector Name	WIRE TO WIRE
Connector Type	1K33FW-NS10

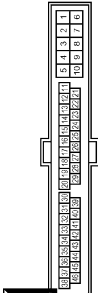

Terminal No.	Color of Wire	Signal Name [Specification]
2	G	-
35	L	-
36	P	-
43	P	-
44	L	-

Connector No.	F108
Connector Name	AMD CONTROL UNIT
Connector Type	TH16FW-NH



Terminal No.	Color of Wire	Signal Name [Specification]
8	L	CAN-H
16	P	CAN-L

Connector No.	F151
Connector Name	TOM (TRANSMISSION CONTROL MODULE)
Connector Type	SPT0BCY

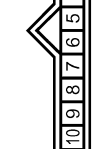

Terminal No.	Color of Wire	Signal Name [Specification]
1	BR	CAN-H
2	L/Y	CAN-L

Connector No.	M1
Connector Name	FUSE BLOCK (J/B)
Connector Type	NS06FW-M2

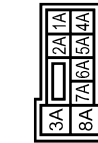

Terminal No.	Color of Wire	Signal Name [Specification]
1A	GR	-
2A	G	-
5A	V	-

Connector No.	M3
Connector Name	FUSE BLOCK (J/B)
Connector Type	NS12FW-CS

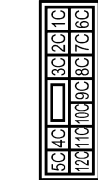

Terminal No.	Color of Wire	Signal Name [Specification]
12C	O	-

Connector No.	M6
Connector Name	WIRE TO WIRE
Connector Type	TH60MP-CS16-TM4



Terminal No.	Color of Wire	Signal Name [Specification]
41	W	-
42	BR	-
43	P	-
59	V	-
60	L	-
81	P	-
82	L	-



# UNIFIED METER AND A/C AMP.

< ECU DIAGNOSIS INFORMATION >

## METER

Connector No.	M7
Connector Name	WIRE TO WIRE
Connector Type	TH20MW-CS16-TM4



Terminal No.	Color of Wire	Signal Name [Specification]
34	L	-
35	P	-
36	L	-
37	P	-
84	SB	-
87	Y	-
89	BR	-

Connector No.	M16
Connector Name	AFS CONTROL UNIT
Connector Type	TH40FW-NH

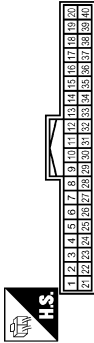

Terminal No.	Color of Wire	Signal Name [Specification]
7	P	CAN-L
30	L	CAN-H

Connector No.	M83
Connector Name	COMBINATION METER
Connector Type	TH40FW-NH

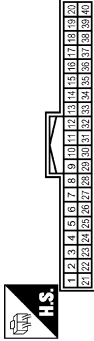

Terminal No.	Color of Wire	Signal Name [Specification]
1	GR	BAT
2	LG	COMM (METER->AMP.)
3	GR	COMM (AMP->METER)
5	B	GND
6	P	ALTERNATOR
7	LG	AIR BAG
10	G	SECURITY
15	B	GND
16	B	METER CONTROL SW GND
21	O	IGN
22	B	GND

24	BR	COMM (LCD->AMP.)
25	Y	COMM (AMP->LCD)
26	R	VEHICLE SPEED (8-PULSE)
27	V	PARKING BRAKE SW
28	W	BRAKE FLUID LEVEL SW
29	SB	SEAT BELT BUCKLE SW (DRIVER SIDE)
30	G	SEAT BELT
31	L	WASHER LEVEL SW
33	B	ILLUMINATION CONTROL
36	LG	SELECT SW
37	SB	ENTER SW
38	L	TRIP A/B RESET SW
39	P	ILLUMINATION CONTROL SW (-)
40	O	ILLUMINATION CONTROL SW (+)

Connector No.	M84
Connector Name	METER CONTROL SWITCH
Connector Type	TH12MW-NH

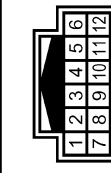

Terminal No.	Color of Wire	Signal Name [Specification]
1	O	-
2	B	-
3	P	-
6	LG	-
7	SB	-

Connector No.	M86
Connector Name	TRIP A/B RESET SWITCH
Connector Type	TK02MW



Terminal No.	Color of Wire	Signal Name [Specification]
1	L	-
2	B	-

Connector No.	M86
Connector Name	UNIFIED METER AND A/C AMP.
Connector Type	TH40FW-NH

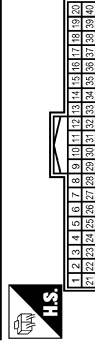

Terminal No.	Color of Wire	Signal Name [Specification]
5	L	SHIFT UP
7	GR	COMMUNICATION SIGNAL (AMP->METER)
8	L	VEHICLE SPEED (2-PULSE)
9	SB	SEAT BELT BUCKLE SWITCH (DRIVER SIDE)
10	W	MANUAL MODE
11	G	NOT MANUAL MODE
14	BR	COMMUNICATION SIGNAL (LCD->AMP)
25	V	SHIFT DOWN
27	LG	COMMUNICATION SIGNAL (METER->AMP)
28	R	VEHICLE SPEED (8-PULSE)
30	V	PARKING BRAKE SWITCH

34	Y	COMMUNICATION SIGNAL (AMP->LCD)
----	---	---------------------------------

JCNWA1794GB

A  
B  
C  
D  
E  
F  
G  
H  
I  
J  
K  
L  
M  
MWI  
O  
P

# UNIFIED METER AND A/C AMP.

< ECU DIAGNOSIS INFORMATION >

## METER

Connector No.	M87
Connector Name	UNIFIED METER AND A/C AMP.
Connector Type	TH32FW-NH

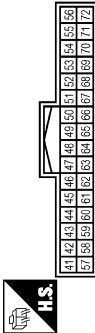

Terminal No.	Color of Wire	Signal Name [Specification]
41	V	ACC POWER SUPPLY
42	Y	FUEL LEVEL SENSOR SIGNAL
45	P	AMBIENT SENSOR SIGNAL
53	G	IGNITION POWER SUPPLY
54	Y	BATTERY POWER SUPPLY
55	B	GROUND
56	L	CAN-H
57	W	BRAKE FLUID LEVEL SWITCH
58	BR	FUEL LEVEL SENSOR GROUND
61	BR	AMBIENT SENSOR GROUND
71	B	GROUND

Connector No.	M87
Connector Name	AV CONTROL UNIT (WITH NAVI)
Connector Type	TH40FW-NH

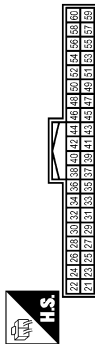

Terminal No.	Color of Wire	Signal Name [Specification]
52	L	CAN-H
53	P	CAN-L

72	P	CAN-L
----	---	-------

Connector No.	M83
Connector Name	AV CONTROL UNIT (WITHOUT NAVI)
Connector Type	TH24FW-NH



Terminal No.	Color of Wire	Signal Name [Specification]
44	BR	COMM (DISP->CONT)
55	SHIELD	SHIELD
56	Y	COMM (CONT->DISP)

Connector No.	M107
Connector Name	ECM
Connector Type	RH24FGY-R25-R-LH-Z



Terminal No.	Color of Wire	Signal Name [Specification]
113	P	VEHCAN-L
114	L	VEHCAN-H

Connector No.	M85
Connector Name	AV CONTROL UNIT (WITHOUT NAVI)
Connector Type	TH32FW-NH

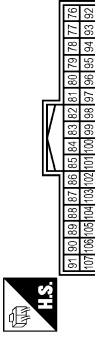

Terminal No.	Color of Wire	Signal Name [Specification]
86	L	CAN-H
87	P	CAN-L

Connector No.	M116
Connector Name	WIRE TO WIRE
Connector Type	TK36MP-NS10



Terminal No.	Color of Wire	Signal Name [Specification]
2	P	-
35	L	-
36	P	-
43	P	-
44	L	-

JCNWA1795GB

# UNIFIED METER AND A/C AMP.

< ECU DIAGNOSIS INFORMATION >

## METER

Connector No.	Connector Name	Connector Type	Terminal No.	Color of Wire	Signal Name [Specification]
M122	BCM (BODY CONTROL MODULE)	TH40FB-NH	90	P	CAN-L
			91	L	CAN-H
M123	BCM (BODY CONTROL MODULE)	TH40FG-NH	141	G	SECURITY INDICATOR OUTPUT
M137	A/T SHIFT SELECTOR	TH12FW-NH	1	W	-
			2	V	-
			3	L	-
			4	B	-
			5	G	-
M147	AIR BAG DIAGNOSIS SENSOR UNIT	TR2BFY-EX-SC	15	LG	AIR BAG W/L
			24	G	SEAT BELT

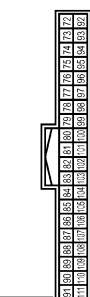
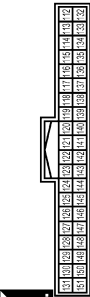
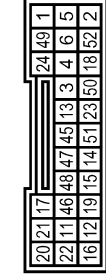

A  
B  
C  
D  
E  
F  
G  
H  
I  
J  
K  
L  
M  
N  
O  
P

MWI

JCNWA1796GB

INFOID:000000004348137

## Fail-Safe

### FAIL-SAFE

The unified meter and A/C amp. activates the fail-safe control if CAN communication with each unit is malfunctioning.

# UNIFIED METER AND A/C AMP.

## < ECU DIAGNOSIS INFORMATION >

Function	Specifications	
Speedometer	Reset to zero by suspending communication.	
Tachometer		
Fuel gauge		
Water temperature gauge		
Illumination control	When suspending communication, change to nighttime mode.	
Information display	The display turns off by suspending communication.	
Buzzer	The buzzer turns off by suspending communication.	
Warning lamp/indicator lamp	ABS warning lamp	The lamp turns on by suspending communication.
	VDC OFF indicator lamp	
	SLIP indicator lamp	
	Brake warning lamp	
	CRUISE warning lamp	
	IBA OFF indicator lamp	
	AWD warning lamp	
	Low tire pressure warning lamp	
	Master warning lamp	The lamp blinking caused by communication malfunction
	AFS OFF indicator lamp	
	High beam indicator	The lamp turns off by suspending communication.
	Turn signal indicator lamp	
	Tail lamp indicator lamp	
	Oil pressure warning lamp	
	Malfunction indicator lamp	
	A/T CHECK warning lamp	
	Key warning lamp	
Lane departure warning lamp		
LDP ON indicator lamp		

## DTC Index

INFOID:000000004348138

Display contents of CONSULT-III	Time	Diagnostic item is detected when ...	Refer to
CAN COMM CIRCUIT [U1000]	CRNT, 1 - 39	When unified meter and A/C amp. is not transmitting or receiving CAN communication signal for 2 seconds or more.	<a href="#">MWI-44</a>
CONTROL UNIT (CAN) [U1010]	CRNT, 1 - 39	When detecting error during the initial diagnosis of CAN controller of unified meter and A/C amp.	<a href="#">MWI-45</a>
COMM ERROR 1 [B2201]	CRNT, 1 - 39	If a communication error is present in the communication line between unified meter and A/C amp. and combination meter for 2 seconds or more.	<a href="#">MWI-46</a>
COMM ERROR 2 [B2202]	CRNT, 1 - 39	If a communication error is present in the communication line between unified meter and A/C amp. and combination meter for 2 seconds or more.	<a href="#">MWI-48</a>
VEHICLE SPEED [B2205]	CRNT, 1 - 39	The abnormal vehicle speed signal is input from ABS actuator and electric unit (control unit) for 2 seconds or more.	<a href="#">MWI-50</a>
ENGINE SPEED [B2267]	CRNT, 1 - 39	If ECM continuously transmits abnormal engine speed signals for 2 seconds or more.	<a href="#">MWI-51</a>
WATER TEMP [B2268]	CRNT, 1 - 39	If ECM continuously transmits abnormal engine coolant temperature signals for 60 seconds or more.	<a href="#">MWI-52</a>

# IPDM E/R (INTELLIGENT POWER DISTRIBUTION MODULE ENGINE ROOM)

< ECU DIAGNOSIS INFORMATION >

## IPDM E/R (INTELLIGENT POWER DISTRIBUTION MODULE ENGINE ROOM)

Reference Value

INFOID:000000004683989

VALUES ON THE DIAGNOSIS TOOL

Monitor Item	Condition		Value/Status
RAD FAN REQ	Engine idle speed	Changes depending on engine coolant temperature, air conditioner operation status, vehicle speed, etc.	0 – 100 %
AC COMP REQ	Engine running	A/C switch OFF	Off
		A/C switch ON (Compressor is operating)	On
TAIL&CLR REQ	Lighting switch OFF		Off
	Lighting switch 1ST, 2ND, HI or AUTO (Light is illuminated)		On
HL LO REQ	Lighting switch OFF		Off
	Lighting switch 2ND HI or AUTO (Light is illuminated)		On
HL HI REQ	Lighting switch OFF		Off
	Lighting switch HI		On
FR FOG REQ	Lighting switch 2ND or AUTO (Light is illuminated)	Front fog lamp switch OFF	Off
		<ul style="list-style-type: none"> <li>• Front fog lamp switch ON</li> <li>• Daytime running light activated (Only for Canada)</li> </ul>	On
FR WIP REQ	Ignition switch ON	Front wiper switch OFF	Stop
		Front wiper switch INT	1LOW
		Front wiper switch LO	Low
		Front wiper switch HI	Hi
WIP AUTO STOP	Ignition switch ON	Front wiper stop position	STOP P
		Any position other than front wiper stop position	ACT P
WIP PROT	Ignition switch ON	Front wiper operates normally	Off
		Front wiper stops at fail-safe operation	BLOCK
IGN RLY1 -REQ	Ignition switch OFF or ACC		Off
	Ignition switch ON		On
IGN RLY	Ignition switch OFF or ACC		Off
	Ignition switch ON		On
PUSH SW	Release the push-button ignition switch		Off
	Press the push-button ignition switch		On
INTER/NP SW	Ignition switch ON	Selector lever in any position other than P or N	Off
		Selector lever in P or N position	On
ST RLY CONT	Ignition switch ON		Off
	At engine cranking		On
IHBT RLY -REQ	Ignition switch ON		Off
	At engine cranking		On

A  
B  
C  
D  
E  
F  
G  
H  
I  
J  
K  
L  
M

MWI

O  
P

# IPDM E/R (INTELLIGENT POWER DISTRIBUTION MODULE ENGINE ROOM)

## < ECU DIAGNOSIS INFORMATION >

Monitor Item	Condition	Value/Status
ST/INHI RLY	Ignition switch ON	Off
	At engine cranking	INHI ON → ST ON
	The status of starter relay or starter control relay cannot be recognized by the battery voltage malfunction, etc. when the starter relay is ON and the starter control relay is OFF	UNKWN
DETENT SW	Ignition switch ON <ul style="list-style-type: none"> <li>• Press the selector button with selector lever in P position</li> <li>• Selector lever in any position other than P</li> </ul>	Off
	Release the selector button with selector lever in P position	On
S/L RLY -REQ	None of the conditions below are present	Off
	<ul style="list-style-type: none"> <li>• Open the driver door after the ignition switch is turned OFF (for a few seconds)</li> <li>• Press the push-button ignition switch when the steering lock is activated</li> </ul>	On
S/L STATE	Steering lock is activated	LOCK
	Steering lock is deactivated	UNLOCK
	[DTC: B210A] is detected	UNKWN
DTRL REQ	<b>NOTE:</b> The item is indicated, but not monitored.	Off
OIL P SW	Ignition switch OFF, ACC or engine running	Open
	Ignition switch ON	Close
HOOD SW	Close the hood	Off
	Open the hood	On
HL WASHER REQ	<b>NOTE:</b> The item is indicated, but not monitored.	Off
THFT HRN REQ	Not operation	Off
	<ul style="list-style-type: none"> <li>• Panic alarm is activated</li> <li>• Horn is activated with VEHICLE SECURITY (THEFT WARNING) SYSTEM</li> </ul>	On
HORN CHIRP	Not operating	Off
	Door locking with Intelligent Key (horn chirp mode)	On
CRNRNG LMP REQ	<b>NOTE:</b> The item is indicated, but not monitored.	Off

# IPDM E/R (INTELLIGENT POWER DISTRIBUTION MODULE ENGINE ROOM)

< ECU DIAGNOSIS INFORMATION >

## TERMINAL LAYOUT

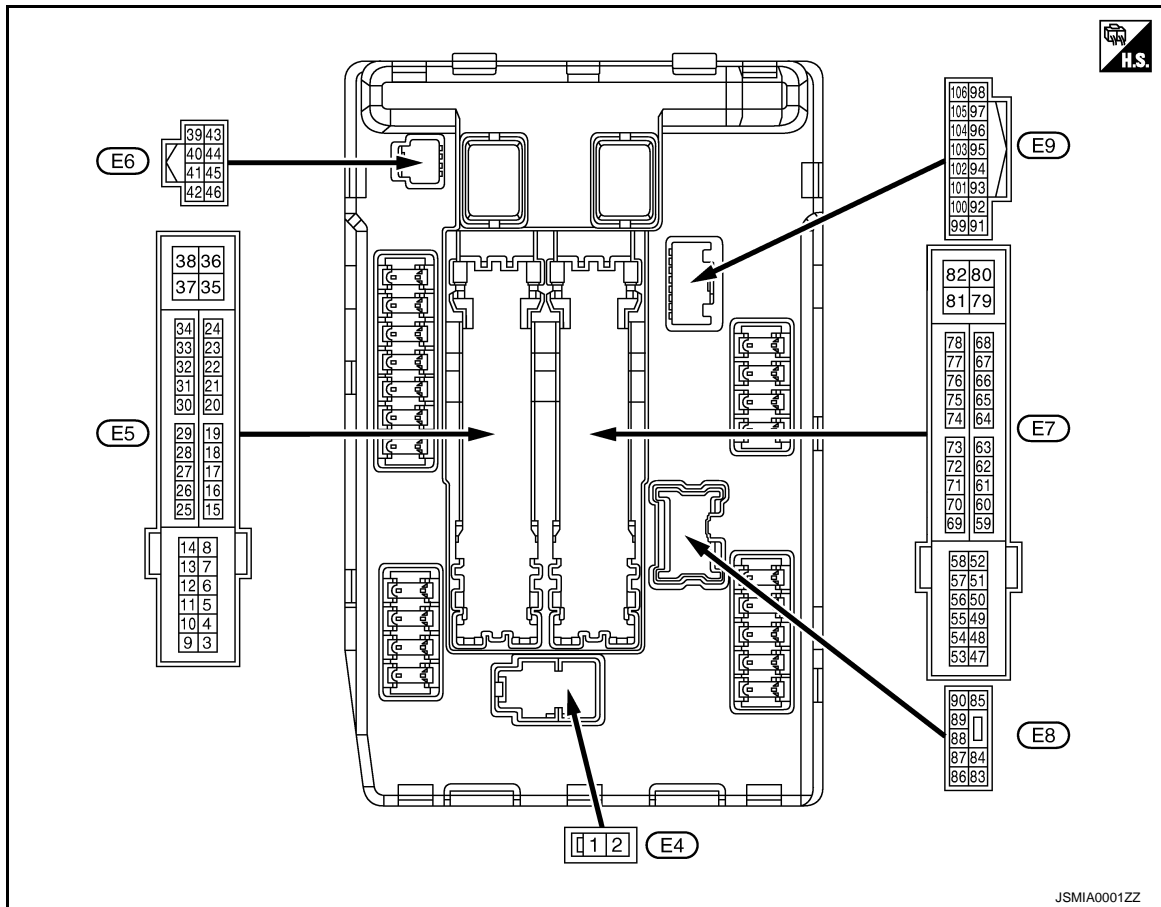

## PHYSICAL VALUES

Terminal No. (Wire color)		Description		Condition		Value (Approx.)
+	-	Signal name	Input/ Output			
1 (W)	Ground	Battery power supply	Input	Ignition switch OFF		Battery voltage
2 (L)	Ground	Battery power supply	Input	Ignition switch OFF		Battery voltage
4 (V)	Ground	Front wiper LO	Output	Ignition switch OFF	Front wiper switch OFF	0 V
				Ignition switch ON	Front wiper switch LO	Battery voltage
5 (L)	Ground	Front wiper HI	Output	Ignition switch OFF	Front wiper switch OFF	0 V
				Ignition switch ON	Front wiper switch HI	Battery voltage
7 (R)	Ground	Tail, license plate lamps & interior lamps	Output	Ignition switch OFF	Lighting switch OFF	0 V
				Ignition switch ON	Lighting switch 1ST	Battery voltage
11 (BR)	Ground	Steering lock unit power supply	Output	Ignition switch OFF	A few seconds after opening the driver door	Battery voltage
				Ignition switch LOCK	Press the push-button ignition switch	Battery voltage
				Ignition switch ACC or ON		0 V
12 (B/W)	Ground	Ground	—	Ignition switch ON		0 V

# IPDM E/R (INTELLIGENT POWER DISTRIBUTION MODULE ENGINE ROOM)

## < ECU DIAGNOSIS INFORMATION >

Terminal No. (Wire color)		Description		Condition		Value (Approx.)
+	-	Signal name	Input/ Output			
13 (SB)	Ground	Fuel pump power supply	Output	Approximately 1 second or more after turning the ignition switch ON		0 V
				<ul style="list-style-type: none"> <li>Approximately 1 second after turning the ignition switch ON</li> <li>Engine running</li> </ul>		Battery voltage
16 (LG)	Ground	Front wiper auto stop	Input	Ignition switch ON	Front wiper stop position	0 V
					Any position other than front wiper stop position	Battery voltage
19 (W)	Ground	Ignition relay power supply	Output	Ignition switch OFF		0 V
				Ignition switch ON		Battery voltage
25 (G)	Ground	Ignition relay power supply	Output	Ignition switch OFF		0 V
				Ignition switch ON		Battery voltage
26* (R)	Ground	Ignition relay power supply	Output	Ignition switch OFF		0 V
				Ignition switch ON		Battery voltage
27 (O)	Ground	Ignition relay monitor	Input	Ignition switch OFF or ACC		Battery voltage
				Ignition switch ON		0 V
28 (L)	Ground	Push-button ignition switch	Input	Press the push-button ignition switch		0 V
				Release the push-button ignition switch		Battery voltage
30 (GR)	Ground	Starter relay control	Input	Ignition switch ON	Selector lever in any position other than P or N	0 V
					Selector lever P or N	Battery voltage
32 (L)	Ground	Steering lock unit condition-1	Input	Steering lock is activated		0 V
				Steering lock is deactivated		Battery voltage
33 (P)	Ground	Steering lock unit condition-2	Input	Steering lock is activated		Battery voltage
				Steering lock is deactivated		0 V
36 (G)	Ground	Battery power supply	Input	Ignition switch OFF		Battery voltage
39 (P)	—	CAN-L	Input/ Output	—		—
40 (L)	—	CAN-H	Input/ Output	—		—
41 (B/W)	Ground	Ground	—	Ignition switch ON		0 V
42 (Y)	Ground	Cooling fan relay control	Input	Ignition switch OFF or ACC		0 V
				Ignition switch ON		0.7 V
43 (SB)	Ground	Control device (Detention switch)	Input	Ignition switch ON	<ul style="list-style-type: none"> <li>Press the selector button (Selector lever P)</li> <li>Selector lever in any position other than P</li> </ul>	Battery voltage
					Release the selector button (selector lever P)	0 V
44 (W)	Ground	Horn relay control	Input	The horn is deactivated		Battery voltage
				The horn is activated		0 V
45 (G)	Ground	Anti theft horn relay control	Input	The horn is deactivated		Battery voltage
				The horn is activated		0 V



# IPDM E/R (INTELLIGENT POWER DISTRIBUTION MODULE ENGINE ROOM)

## < ECU DIAGNOSIS INFORMATION >

Terminal No. (Wire color)		Description		Condition		Value (Approx.)	
46 (R)	Ground	Starter relay control	Input	Ignition switch ON	Selector lever in any position other than P or N	0 V	A
					Selector lever P or N	Battery voltage	B
48 (L)	Ground	A/C relay power supply	Output	Engine running	A/C switch OFF	0 V	C
					A/C switch ON (A/C compressor is operating)	Battery voltage	D
49 (R)	Ground	ECM relay power supply	Output		Ignition switch OFF (More than a few seconds after turning ignition switch OFF)	0 V	E
					<ul style="list-style-type: none"> <li>• Ignition switch ON</li> <li>• Ignition switch OFF (For a few seconds after turning ignition switch OFF)</li> </ul>	Battery voltage	F
51 (G)	Ground	Ignition relay power supply	Output		Ignition switch OFF	0 V	G
					Ignition switch ON	Battery voltage	H
53 (W)	Ground	ECM relay power supply	Output		Ignition switch OFF (More than a few seconds after turning ignition switch OFF)	0 V	I
					<ul style="list-style-type: none"> <li>• Ignition switch ON</li> <li>• Ignition switch OFF (For a few seconds after turning ignition switch OFF)</li> </ul>	Battery voltage	J
54 (LG)	Ground	Throttle control motor relay power supply	Output		Ignition switch OFF (More than a few seconds after turning ignition switch OFF)	0 V	K
					<ul style="list-style-type: none"> <li>• Ignition switch ON</li> <li>• Ignition switch OFF (For a few seconds after turning ignition switch OFF)</li> </ul>	Battery voltage	L
55 (BR)	Ground	ECM power supply	Output		Ignition switch OFF	Battery voltage	M
56 (V)	Ground	Ignition relay power supply	Output		Ignition switch OFF	0 V	
					Ignition switch ON	Battery voltage	
57 (SB)	Ground	Ignition relay power supply	Output		Ignition switch OFF	0 V	
					Ignition switch ON	Battery voltage	
58 (P)	Ground	Ignition relay power supply	Output		Ignition switch OFF	0 V	
					Ignition switch ON	Battery voltage	
69 (W)	Ground	ECM relay control	Output		Ignition switch OFF (More than a few seconds after turning ignition switch OFF)	Battery voltage	
					<ul style="list-style-type: none"> <li>• Ignition switch ON</li> <li>• Ignition switch OFF (For a few seconds after turning ignition switch OFF)</li> </ul>	0 – 1.5 V	
70 (O)	Ground	Throttle control motor relay control	Output		Ignition switch ON → OFF	0 – 1.0 V ↓ Battery voltage ↓ 0 V	
					Ignition switch ON	0 – 1.0 V	

MWI

# IPDM E/R (INTELLIGENT POWER DISTRIBUTION MODULE ENGINE ROOM)

## < ECU DIAGNOSIS INFORMATION >

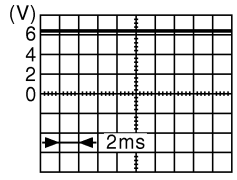
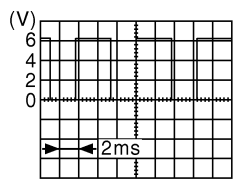
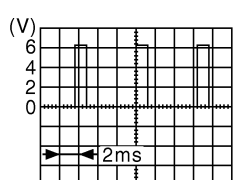
Terminal No. (Wire color)		Description		Condition		Value (Approx.)
+	-	Signal name	Input/ Output			
74 (P)	Ground	Ignition relay power supply	Output	Ignition switch OFF		0 V
				Ignition switch ON		Battery voltage
75 (Y)	Ground	Oil pressure switch	Input	Ignition switch ON	Engine stopped	0 V
					Engine running	Battery voltage
76 (V)	Ground	Power generation command signal	Output	Ignition switch ON		 <p style="text-align: right;">JPMIA0001GB</p> <p style="text-align: center;">6.3 V</p>
				40% is set on "ACTIVE TEST", "ALTERNATOR DUTY" of "ENGINE"		 <p style="text-align: right;">JPMIA0002GB</p> <p style="text-align: center;">3.8 V</p>
				80% is set on "ACTIVE TEST", "ALTERNATOR DUTY" of "ENGINE"		 <p style="text-align: right;">JPMIA0003GB</p> <p style="text-align: center;">1.4 V</p>
77 (L)	Ground	Fuel pump relay control	Output	<ul style="list-style-type: none"> <li>Approximately 1 second after turning the ignition switch ON</li> <li>Engine running</li> </ul>		0 – 1.0 V
				Approximately 1 second or more after turning the ignition switch ON		Battery voltage
80 (W)	Ground	Starter motor	Output	At engine cranking		Battery voltage
83 (O)	Ground	Headlamp LO (RH)	Output	Ignition switch ON	Lighting switch OFF	0 V
					Lighting switch 2ND	Battery voltage
84 (V)	Ground	Headlamp LO (LH)	Output	Ignition switch ON	Lighting switch OFF	0 V
					Lighting switch 2ND	Battery voltage
86 (W)	Ground	Front fog lamp (RH)	Output	Lighting switch 2ND	Front fog lamp switch OFF	0 V
				<ul style="list-style-type: none"> <li>Front fog lamp switch ON</li> <li>Daytime running light activated (Only for Canada)</li> </ul>		Battery voltage

# IPDM E/R (INTELLIGENT POWER DISTRIBUTION MODULE ENGINE ROOM)

## < ECU DIAGNOSIS INFORMATION >

Terminal No. (Wire color)		Description		Condition		Value (Approx.)
+	-	Signal name	Input/ Output			
87 (L)	Ground	Front fog lamp (LH)	Output	Lighting switch 2ND	Front fog lamp switch OFF	0 V
					<ul style="list-style-type: none"> <li>• Front fog lamp switch ON</li> <li>• Daytime running light activated (Only for Canada)</li> </ul>	Battery voltage
88 (GR)	Ground	Washer pump power supply	Output	Ignition switch ON		Battery voltage
89 (BR)	Ground	Headlamp HI (RH)	Output	Ignition switch ON	Lighting switch OFF	0 V
					<ul style="list-style-type: none"> <li>• Lighting switch HI</li> <li>• Lighting switch PASS</li> </ul>	Battery voltage
90 (P)	Ground	Headlamp HI (LH)	Output	Ignition switch ON	Lighting switch OFF	0 V
					<ul style="list-style-type: none"> <li>• Lighting switch HI</li> <li>• Lighting switch PASS</li> </ul>	Battery voltage
91 (P)	Ground	Parking lamp (RH)	Output	Ignition switch ON	Lighting switch OFF	0 V
					Lighting switch 1ST	Battery voltage
92 (O)	Ground	Parking lamp (LH)	Output	Ignition switch ON	Lighting switch OFF	0 V
					Lighting switch 1ST	Battery voltage
97 (V)	Ground	Cooling fan control	Output	Engine idling		0 – 5 V
104 (LG)	Ground	Hood switch	Input	Close the hood		Battery voltage
				Open the hood		0 V

\*: Only for the models with ICC system

A  
B  
C  
D  
E  
F  
G  
H  
I  
J  
K  
L  
M  
N  
O  
P

MWI

# IPDM E/R (INTELLIGENT POWER DISTRIBUTION MODULE ENGINE ROOM)

< ECU DIAGNOSIS INFORMATION >

## Wiring Diagram - IPDM E/R -

INFOID:000000004683990

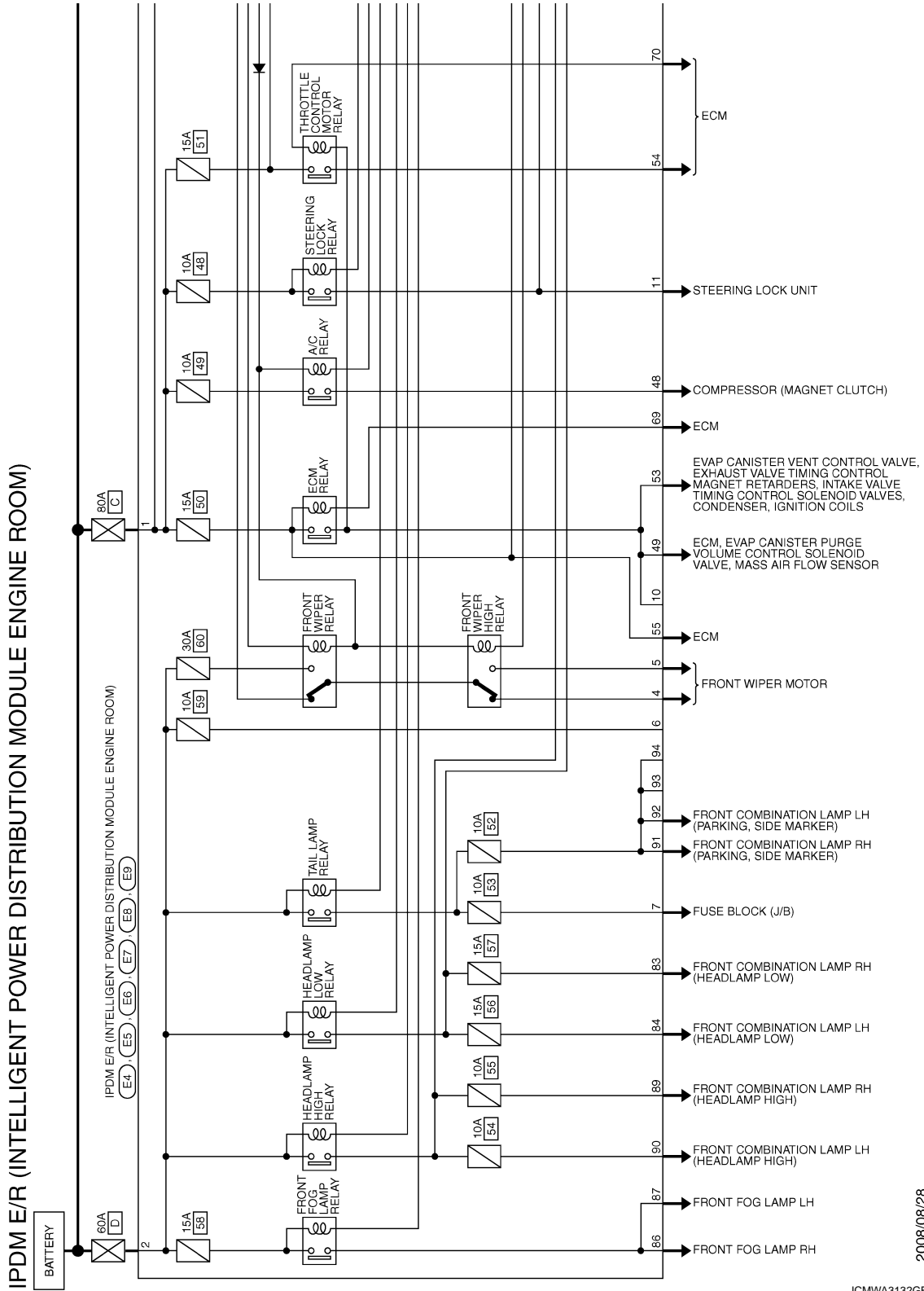

2008/08/28

JCMWA3132GB

# IPDM E/R (INTELLIGENT POWER DISTRIBUTION MODULE ENGINE ROOM)

< ECU DIAGNOSIS INFORMATION >

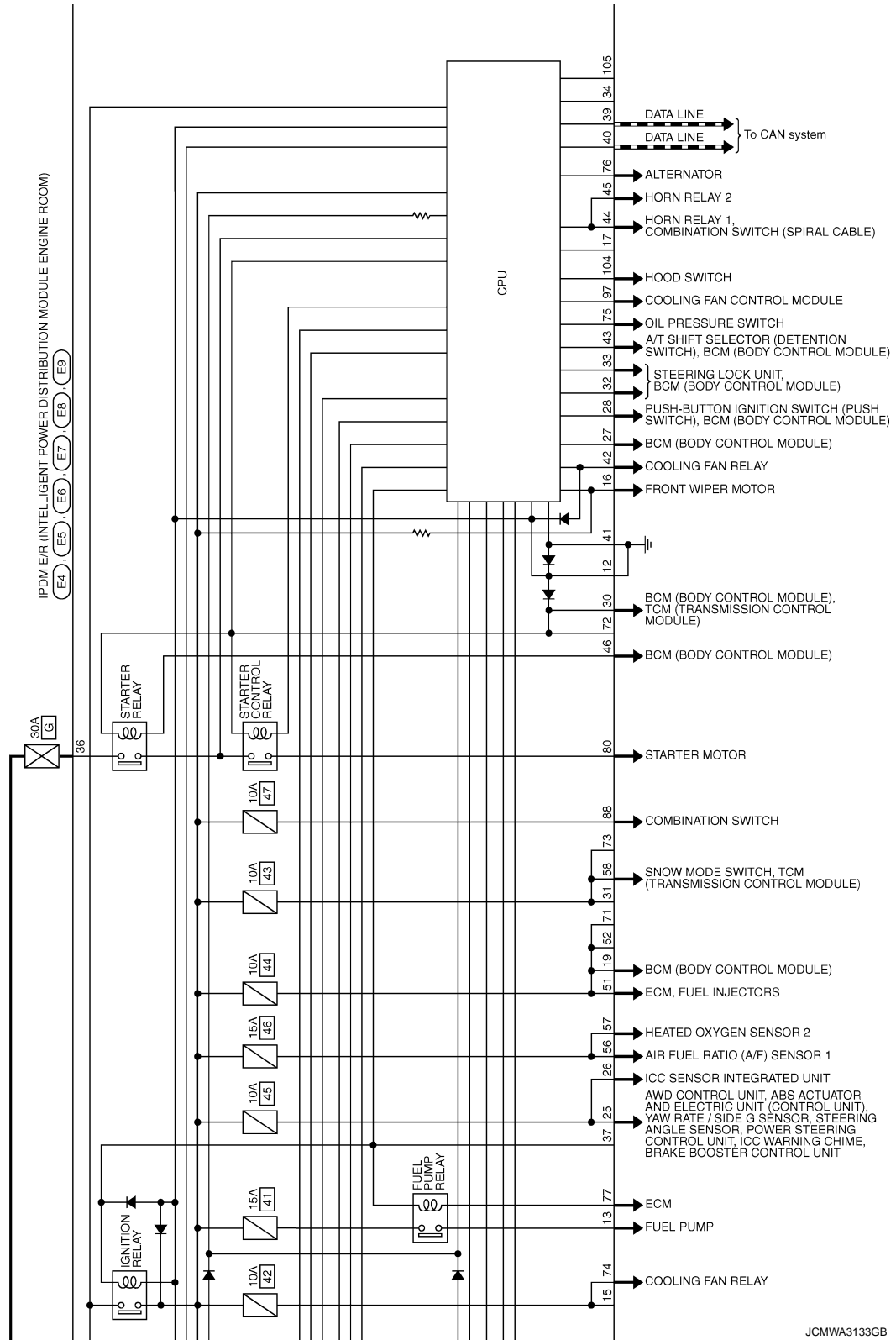

JCMWA3133GB

A  
B  
C  
D  
E  
F  
G  
H  
I  
J  
K  
L  
M  
N  
O  
P

MWI

# IPDM E/R (INTELLIGENT POWER DISTRIBUTION MODULE ENGINE ROOM)

< ECU DIAGNOSIS INFORMATION >

---

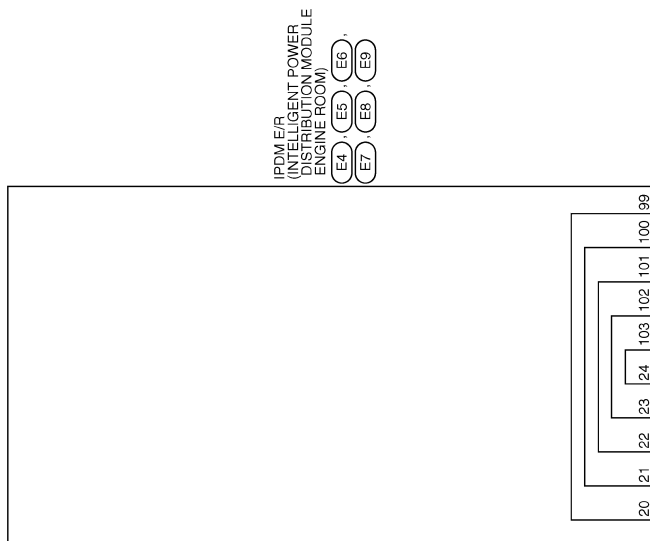

JCMWA3134GB

# IPDM E/R (INTELLIGENT POWER DISTRIBUTION MODULE ENGINE ROOM)

< ECU DIAGNOSIS INFORMATION >

**IPDM E/R (INTELLIGENT POWER DISTRIBUTION MODULE ENGINE ROOM)**

Connector No.	E4
Connector Name	IPDM E/R (INTELLIGENT POWER DISTRIBUTION MODULE ENGINE ROOM)
Connector Type	L02FB-MC

Terminal No.	Color of Wire	Signal Name [Specification]
1	W	-
2	L	-

**IPDM E/R (INTELLIGENT POWER DISTRIBUTION MODULE ENGINE ROOM)**

Connector No.	E5
Connector Name	IPDM E/R (INTELLIGENT POWER DISTRIBUTION MODULE ENGINE ROOM)
Connector Type	TH20FW-CS12-M4-TV

Terminal No.	Color of Wire	Signal Name [Specification]
4	V	-
5	L	-
7	R	-
11	BR	-
12	B/W	-
13	SB	-
16	LG	-
19	W	-
25	G	-
26	R	-
27	O	-

**IPDM E/R (INTELLIGENT POWER DISTRIBUTION MODULE ENGINE ROOM)**

Connector No.	E6
Connector Name	IPDM E/R (INTELLIGENT POWER DISTRIBUTION MODULE ENGINE ROOM)
Connector Type	TH08FW-NH

Terminal No.	Color of Wire	Signal Name [Specification]
39	P	-
40	L	-
41	B/W	-
42	Y	-
43	SB	-
44	W	-
45	G	-
46	R	-

**IPDM E/R (INTELLIGENT POWER DISTRIBUTION MODULE ENGINE ROOM)**

Connector No.	E7
Connector Name	IPDM E/R (INTELLIGENT POWER DISTRIBUTION MODULE ENGINE ROOM)
Connector Type	TH20FW-CS12-M8

Terminal No.	Color of Wire	Signal Name [Specification]
48	L	-
49	R	-
51	G	-
53	W	-
54	LG	-
55	BR	-
56	V	-
59	SB	-
58	P	-
68	W	-
70	O	-

**IPDM E/R (INTELLIGENT POWER DISTRIBUTION MODULE ENGINE ROOM)**

Connector No.	E8
Connector Name	IPDM E/R (INTELLIGENT POWER DISTRIBUTION MODULE ENGINE ROOM)
Connector Type	NS08FW-CS

Terminal No.	Color of Wire	Signal Name [Specification]
83	O	-
84	V	-
86	W	-
87	L	-
88	GR	-
89	BR	-
90	P	-

**IPDM E/R (INTELLIGENT POWER DISTRIBUTION MODULE ENGINE ROOM)**

Connector No.	E9
Connector Name	IPDM E/R (INTELLIGENT POWER DISTRIBUTION MODULE ENGINE ROOM)
Connector Type	TH16FW-NH

Terminal No.	Color of Wire	Signal Name [Specification]
91	P	-
92	O	-
97	V	-
104	LG	-

A  
B  
C  
D  
E  
F  
G  
H  
I  
J  
K  
L  
M  
MWI  
O  
P

## Fail-safe

### CAN COMMUNICATION CONTROL

When CAN communication with ECM and BCM is impossible, IPDM E/R performs fail-safe control. After CAN communication recovers normally, it also returns to normal control.

If No CAN Communication Is Available With ECM

JCMWA3135GB

INFOID:000000004683991

# IPDM E/R (INTELLIGENT POWER DISTRIBUTION MODULE ENGINE ROOM)

## < ECU DIAGNOSIS INFORMATION >

Control part	Fail-safe operation
Cooling fan	<ul style="list-style-type: none"> <li>• Outputs the pulse duty signal (PWM signal) 100% when the ignition switch is turned ON</li> <li>• Outputs the pulse duty signal (PWM signal) 0% when the ignition switch is turned OFF</li> </ul>
A/C compressor	A/C relay OFF
Alternator	Outputs the power generation command signal (PWM signal) 0%

### If No CAN Communication Is Available With BCM

Control part	Fail-safe operation
Headlamp	<ul style="list-style-type: none"> <li>• Turns ON the headlamp low relay when the ignition switch is turned ON</li> <li>• Turns OFF the headlamp low relay when the ignition switch is turned OFF</li> <li>• Headlamp high relay OFF</li> </ul>
<ul style="list-style-type: none"> <li>• Parking lamps</li> <li>• License plate lamps</li> <li>• Side maker lamps</li> <li>• Illuminations</li> <li>• Tail lamps</li> </ul>	<ul style="list-style-type: none"> <li>• Turns ON the tail lamp relay when the ignition switch is turned ON</li> <li>• Turns OFF the tail lamp relay when the ignition switch is turned OFF</li> </ul>
Front wiper	<ul style="list-style-type: none"> <li>• The status just before activation of fail-safe control is maintained until the ignition switch is turned OFF while the front wiper is operating at LO or HI speed.</li> <li>• The wiper is operated at LO speed until the ignition switch is turned OFF if the fail-safe control is activated while the front wiper is set in the INT mode and the front wiper motor is operating.</li> </ul>
Front fog lamps	Front fog lamp relay OFF
Horn	Horn relay OFF
Ignition relay	The status just before activation of fail-safe is maintained.
Starter motor	Starter control relay OFF
Steering lock unit	Steering lock relay OFF

### IGNITION RELAY MALFUNCTION DETECTION FUNCTION

- IPDM E/R monitors the voltage at the contact circuit and excitation coil circuit of the ignition relay inside it.
- IPDM E/R judges the ignition relay error if the voltage differs between the contact circuit and the excitation coil circuit.
- If the ignition relay cannot turn OFF due to contact seizure, it activates the tail lamp relay for 10 minutes to alert the user to the ignition relay malfunction when the ignition switch is turned OFF.

Voltage judgment		IPDM E/R judgment	Operation
Ignition relay contact side	Ignition relay excitation coil side		
ON	ON	Ignition relay ON normal	—
OFF	OFF	Ignition relay OFF normal	—
ON	OFF	Ignition relay ON stuck	<ul style="list-style-type: none"> <li>• Detects DTC "B2098: IGN RELAY ON"</li> <li>• Turns ON the tail lamp relay for 10 minutes</li> </ul>
OFF	ON	Ignition relay OFF stuck	Detects DTC "B2099: IGN RELAY OFF"

### FRONT WIPER CONTROL

IPDM E/R detects front wiper stop position by a front wiper stop position signal.

When a front wiper stop position signal is in the conditions listed below, IPDM E/R stops power supply to wiper after repeating a front wiper 10 seconds activation and 20 seconds stop five times.



# IPDM E/R (INTELLIGENT POWER DISTRIBUTION MODULE ENGINE ROOM)

## < ECU DIAGNOSIS INFORMATION >

Ignition switch	Front wiper switch	Front wiper stop position signal
ON	OFF	The front wiper stop position signal (stop position) cannot be input for 10 seconds.
	ON	The front wiper stop position signal does not change for 10 seconds.

### NOTE:

This operation status can be confirmed on the IPDM E/R “Data Monitor” that displays “BLOCK” for the item “WIP PROT” while the wiper is stopped.

### STARTER MOTOR PROTECTION FUNCTION

IPDM E/R turns OFF the starter control relay to protect the starter motor when the starter control relay remains active for 90 seconds.

### DTC Index

INFOID:000000004683992

### NOTE:

- The details of time display are as follows.
  - CRNT: A malfunction is detected now.
  - PAST: A malfunction was detected in the past.
- IGN counter is displayed on FFD (Freeze Frame data).
  - The number is 0 when is detected now.
  - The number increases like 1 → 2 ... 38 → 39 after returning to the normal condition whenever IGN OFF → ON.
  - The number is fixed to 39 until the self-diagnosis results are erased if it is over 39.

x: Applicable

CONSULT display	Fail-safe	Reference
No DTC is detected. further testing may be required.	—	—
U1000: CAN COMM CIRCUIT	×	<a href="#">PCS-15</a>
B2098: IGN RELAY ON	×	<a href="#">PCS-16</a>
B2099: IGN RELAY OFF	—	<a href="#">PCS-17</a>
B2108: STRG LCK RELAY ON	—	<a href="#">SEC-97</a>
B2109: STRG LCK RELAY OFF	—	<a href="#">SEC-98</a>
B210A: STRG LCK STATE SW	—	<a href="#">SEC-99</a>
B210B: START CONT RLY ON	—	<a href="#">SEC-103</a>
B210C: START CONT RLY OFF	—	<a href="#">SEC-104</a>
B210D: STARTER RELAY ON	—	<a href="#">SEC-105</a>
B210E: STARTER RELAY OFF	—	<a href="#">SEC-106</a>
B210F: INTRLCK/PNP SW ON	—	<a href="#">SEC-108</a>
B2110: INTRLCK/PNP SW OFF	—	<a href="#">SEC-110</a>

MWI

# THE FUEL GAUGE POINTER DOES NOT MOVE

< SYMPTOM DIAGNOSIS >

## SYMPTOM DIAGNOSIS

### THE FUEL GAUGE POINTER DOES NOT MOVE

#### Description

INFOID:000000004348148

Fuel gauge needle will not move from a certain position.

#### Diagnosis Procedure

INFOID:000000004348149

#### 1. CHECK UNIFIED METER AND A/C AMP. OUTPUT SIGNAL

1. Connect CONSULT-III.
2. Select the "Data Monitor" for the "METER/M&A" and compare the "FUEL METER" monitor value with the fuel gauge reading on the combination meter. Refer to [MWI-56. "Component Function Check"](#).

##### Does monitor value match fuel gauge reading?

- YES >> GO TO 2.  
NO >> Replace combination meter.

#### 2. CHECK FUEL LEVEL SENSOR SIGNAL CIRCUIT

Check the fuel level sensor signal circuit. Refer to [MWI-56. "Diagnosis Procedure"](#).

##### Is the inspection result normal?

- YES >> GO TO 3.  
NO >> Repair harness or connector.

#### 3. CHECK FUEL LEVEL SENSOR UNIT

Perform a unit check for the fuel level sensor unit. Refer to [MWI-57. "Component Inspection"](#).

##### Is the inspection result normal?

- YES >> GO TO 4.  
NO >> Replace fuel level sensor unit. Refer to [FL-5. "Removal and Installation"](#).

#### 4. CHECK FLOAT INTERFERENCE

Check that the float arm interferes with or binds to other components in the fuel tank.

##### Is the inspection result normal?

- YES >> Replace unified meter and A/C amp.  
NO >> Repair or replace malfunctioning parts.

# THE METER CONTROL SWITCH IS INOPERATIVE

< SYMPTOM DIAGNOSIS >

---

## THE METER CONTROL SWITCH IS INOPERATIVE

### Description

INFOID:000000004348150

If any of the following malfunctions is found for the meter control switch operation.

- All switches are inoperative.
- The specified switch cannot be operated.

### Diagnosis Procedure

INFOID:000000004348151

#### 1. CHECK METER CONTROL SWITCH SIGNAL CIRCUIT

---

Check the meter control switch signal circuit. Refer to [MWI-59, "Diagnosis Procedure"](#).

Is the inspection result normal?

YES >> GO TO 2.

NO >> Repair harness or connector.

#### 2. CHECK METER CONTROL SWITCH UNIT

---

Perform a unit check for the meter control switch. Refer to [MWI-60, "Component Inspection"](#).

Is the inspection result normal?

YES >> Replace combination meter.

NG >> Replace meter control switch.

A  
B  
C  
D  
E  
F  
G  
H  
I  
J  
K  
L  
M  
O  
P

MWI

# THE TRIP A/B RESET SWITCH IS INOPERATIVE

< SYMPTOM DIAGNOSIS >

---

## THE TRIP A/B RESET SWITCH IS INOPERATIVE

### Description

INFOID:000000004348152

The trip A/B reset switch is inoperative.

### Diagnosis Procedure

INFOID:000000004348153

#### 1. CHECK TRIP A/B RESET SWITCH SIGNAL CIRCUIT

---

Check the trip A/B reset switch signal circuit. Refer to [MWI-59, "Diagnosis Procedure"](#).

Is the inspection result normal?

YES >> GO TO 2.

NO >> Repair harness or connector.

#### 2. CHECK TRIP A/B RESET SWITCH UNIT

---

Perform a unit check for the trip A/B reset switch. Refer to [MWI-60, "Component Inspection"](#).

Is the inspection result normal?

YES >> Replace combination meter.

NG >> Replace trip A/B reset switch.

# THE OIL PRESSURE WARNING LAMP DOES NOT TURN ON

< SYMPTOM DIAGNOSIS >

---

## THE OIL PRESSURE WARNING LAMP DOES NOT TURN ON

### Description

INFOID:000000004348154

The oil pressure warning lamp stays off when the ignition switch is turned ON.

### Diagnosis Procedure

INFOID:000000004348155

#### 1.CHECK OIL PRESSURE WARNING LAMP

---

Perform auto active test. Refer to [PCS-10, "Diagnosis Description"](#).

Does oil pressure warning lamp blink?

YES >> GO TO 2.

NO >> Replace combination meter.

#### 2.CHECK OIL PRESSURE SWITCH SIGNAL CIRCUIT

---

Check the oil pressure switch signal circuit. Refer to [MWI-63, "Diagnosis Procedure"](#).

Is the inspection result normal?

YES >> GO TO 3.

NO >> Repair harness or connector.

#### 3.CHECK OIL PRESSURE SWITCH UNIT

---

Perform a unit check for the oil pressure switch. Refer to [MWI-63, "Component Inspection"](#).

Is the inspection result normal?

YES >> Replace IPDM E/R.

NO >> Replace oil pressure switch.

A  
B  
C  
D  
E  
F  
G  
H  
I  
J  
K  
L  
M  
O  
P

MWI

# THE OIL PRESSURE WARNING LAMP DOES NOT TURN OFF

< SYMPTOM DIAGNOSIS >

## THE OIL PRESSURE WARNING LAMP DOES NOT TURN OFF

### Description

INFOID:000000004348156

The oil pressure warning lamp remains illuminated while the engine is running (normal oil pressure).

### Diagnosis Procedure

INFOID:000000004348157

#### 1. CHECK OIL PRESSURE WARNING LAMP

Perform auto active test. Refer to [PCS-10, "Diagnosis Description"](#).

Does oil pressure warning lamp blink?

YES >> GO TO 2.

NO >> Replace combination meter.

#### 2. CHECK IPDM E/R OUTPUT VOLTAGE

1. Disconnect the oil pressure switch connector.
2. Turn ignition switch ON.
3. Check voltage between the oil pressure switch harness connector and ground.

Terminals		Voltage
(+)	(-)	
Oil pressure switch		Approx. 12 V
Connector	Terminal	
F37	1	

Is the inspection result normal?

YES >> GO TO 3.

NO >> GO TO 4.

#### 3. CHECK OIL PRESSURE SWITCH UNIT

Perform a unit check for the oil pressure switch. Refer to [MWI-63, "Component Inspection"](#).

Is the inspection result normal?

YES >> Replace IPDM E/R. Refer to [PCS-33, "Removal and Installation"](#).

NO >> Replace oil pressure switch.

#### 4. CHECK OIL PRESSURE SWITCH SIGNAL CIRCUIT

Check the oil pressure switch signal circuit. Refer to [MWI-63, "Diagnosis Procedure"](#).

Is the inspection result normal?

YES >> Replace IPDM E/R. Refer to [PCS-33, "Removal and Installation"](#).

NO >> Repair harness or connector.

# THE PARKING BRAKE RELEASE WARNING CONTINUES DISPLAYING, OR DOES NOT DISPLAY

< SYMPTOM DIAGNOSIS >

## THE PARKING BRAKE RELEASE WARNING CONTINUES DISPLAYING, OR DOES NOT DISPLAY

### Description

INFOID:000000004348158

- The parking brake warning is displayed during vehicle travel even though the parking brake is released.
- The parking brake warning is not displayed even though driving the vehicle with the parking brake applied.

### Diagnosis Procedure

INFOID:000000004348159

#### 1. CHECK PARKING BRAKE WARNING LAMP OPERATION

1. Start engine.
2. Check the operation of the parking brake warning lamp when operating the parking brake.

Condition	Warning lamp status
Parking brake is applied	ON
Parking brake is released	OFF

Is the inspection result normal?

- YES >> Replace combination meter.
- NO >> GO TO 2.

#### 2. CHECK PARKING BRAKE SWITCH SIGNAL CIRCUIT

1. Turn ignition switch OFF.
2. Check the parking brake switch signal circuit. Refer to [MWI-64, "Diagnosis Procedure"](#).

Is the inspection result normal?

- YES >> GO TO 3.
- NG >> Repair harness or connector.

#### 3. CHECK PARKING BRAKE SWITCH UNIT

Perform a unit check for the parking brake switch. Refer to [BRC-78, "Component Inspection"](#).

Is the inspection result normal?

- YES >> Replace combination meter.
- NO >> Replace parking brake switch.

A  
B  
C  
D  
E  
F  
G  
H  
I  
J  
K  
L  
M  
O  
P

MWI

# THE LOW WASHER FLUID WARNING CONTINUES DISPLAYING, OR DOES NOT DISPLAY

< SYMPTOM DIAGNOSIS >

---

## THE LOW WASHER FLUID WARNING CONTINUES DISPLAYING, OR DOES NOT DISPLAY

### Description

INFOID:000000004348160

- The warning is still displayed even after washer fluid is added.
- The warning is not displayed even though the washer tank is empty.

### Diagnosis Procedure

INFOID:000000004348161

#### 1. CHECK WASHER LEVEL SWITCH SIGNAL CIRCUIT

---

Check the washer level switch signal circuit. Refer to [MWI-66. "Diagnosis Procedure"](#).

Is the inspection result normal?

YES >> GO TO 2.

NO >> Repair harness or connector.

#### 2. CHECK WASHER LEVEL SWITCH UNIT

---

Perform a unit check for the washer level switch. Refer to [MWI-66. "Component Inspection"](#).

Is the inspection result normal?

YES >> Replace combination meter.

NO >> Replace washer level switch. Refer to [WW-103. "Removal and Installation"](#).



# THE DOOR OPEN WARNING CONTINUES DISPLAYING, OR DOES NOT DISPLAY

< SYMPTOM DIAGNOSIS >

## THE DOOR OPEN WARNING CONTINUES DISPLAYING, OR DOES NOT DISPLAY

### Description

INFOID:000000004348162

- The door ajar warning is displayed even though all of the doors are closed.
- The door ajar warning is not displayed even though a door is ajar.

### Diagnosis Procedure

INFOID:000000004348163

#### 1. CHECK BCM INPUT/OUTPUT SIGNAL

Connect CONSULT-III and check the BCM input signals. Refer to [DLK-66, "Component Function Check"](#).

Is the inspection result normal?

YES >> GO TO 2.

NO >> GO TO 3.

#### 2. CHECK UNIFIED METER AND A/C AMP. INPUT SIGNAL

Select the "Data Monitor" for the "METER/M&A" and check the "DOOR W/L" monitor value.

"DOOR W/L"

Door open : On

Door closed : Off

Is the inspection result normal?

YES >> Replace combination meter.

NO >> Replace BCM. Refer to [BCS-85, "Removal and Installation"](#).

#### 3. CHECK DOOR SWITCH SIGNAL CIRCUIT

Check the door switch signal circuit. Refer to [DLK-66, "Diagnosis Procedure"](#).

Is the inspection result normal?

YES >> GO TO 4.

NO >> Repair harness or connector.

#### 4. CHECK DOOR SWITCH UNIT

Perform a unit check for the door switch. Refer to [DLK-68, "Component Inspection"](#).

Is the inspection result normal?

YES >> Replace combination meter.

NO >> Replace applicable door switch. Refer to [DLK-261, "Removal and Installation"](#).

A  
B  
C  
D  
E  
F  
G  
H  
I  
J  
K  
L  
M

MWI

O  
P

# THE AMBIENT TEMPERATURE DISPLAY IS INCORRECT

< SYMPTOM DIAGNOSIS >

---

## THE AMBIENT TEMPERATURE DISPLAY IS INCORRECT

### Description

INFOID:000000004348164

- The displayed ambient air temperature is higher than the actual temperature.
- The displayed ambient air temperature is lower than the actual temperature.

### Diagnosis Procedure

INFOID:000000004348165

#### **NOTE:**

Check that the symptom is not applicable to the normal operating condition before starting diagnosis. Refer to [MWI-123, "INFORMATION DISPLAY : Description"](#).

#### **1.**CHECK AMBIENT SENSOR SIGNAL CIRCUIT

---

Check the ambient sensor signal circuit. Refer to [HAC-89, "Diagnosis Procedure"](#).

Is the inspection result normal?

YES >> GO TO 2.

NO >> Repair harness or connector.

#### **2.**CHECK AMBIENT SENSOR UNIT

---

Perform a unit check for the ambient sensor. Refer to [HAC-90, "Component Inspection"](#).

Is the inspection result normal?

YES >> Replace unified meter and A/C amp.

NO >> Replace ambient sensor. Refer to [HAC-145, "Removal and Installation"](#).

# NORMAL OPERATING CONDITION

< SYMPTOM DIAGNOSIS >

## NORMAL OPERATING CONDITION COMPASS

### COMPASS : Description

INFOID:000000004348166

#### COMPASS

- The electronic compass is highly protected from changes in most magnetic fields. However, some large changes in magnetic fields can affect it. Some examples are (but not limited to): high tension power lines, large steel buildings, subways, steel bridges, automatic car washes, large piles of scrap metal, etc. While this does not happen very often, it is possible.
- During normal operation, the Compass Mirror will continuously update the compass calibration to adjust for gradual changes in the vehicle's magnetic "remnant" field. If the vehicle is subjected to high magnetic influences, the compass may appear to indicate false headings, become locked, or appear that it is unable to be calibrated. If this occurs, perform the calibration procedure.
- If at any time the compass continually displays the incorrect direction or the reading is erratic or locked, verify the correct zone variance.

#### Symptom Chart

Symptom	Cause	Solution / Reference
The compass display reads "C".	<ul style="list-style-type: none"><li>• Compass is not calibrated.</li><li>• Incorrect zone variance setting.</li><li>• Large change in magnetic field (Steel bridges, subways, concentrations of metal, carwashes, etc.)</li><li>• Compass was calibrated incorrectly or in the presence of a strong magnetic field.</li></ul>	Perform calibration. Refer to <a href="#">MWI-34, "Description"</a> .
Compass shows the wrong direction.		
Compass does not change direction appears "Locked".		
Compass does not show all the directions, one or more is missing.		
The compass was calibrated but it "loses" calibration.		
On long trips the compass shows the wrong direction.	Perform zone variation setting if correct reading is desired in that location. Refer to <a href="#">MWI-34, "Description"</a> .	

## INFORMATION DISPLAY

### INFORMATION DISPLAY : Description

INFOID:000000004348167

#### AMBIENT AIR TEMPERATURE

The displayed ambient air temperature on the information display may differ from the actual temperature because it is a corrected value calculated from the ambient sensor signal by the unified meter and A/C amp. Refer to [MWI-29, "INFORMATION DISPLAY : System Description"](#) for details on the correction process.

#### POSSIBLE DRIVING DISTANCE

The calculated possible driving distance may differ from the actual distance to empty if the refueling amount is approximately 15 ℓ (4 US gal, 3-3/10 Imp gal) or less. This is because the refuel control (moves the fuel gauge needle quicker than normal judging that the driver is refueling the vehicle) is not performed in such a case.

A  
B  
C  
D  
E  
F  
G  
H  
I  
J  
K  
L  
M  
O  
P

MWI

# PRECAUTIONS

< PRECAUTION >

## PRECAUTION

### PRECAUTIONS

#### Precaution for Supplemental Restraint System (SRS) "AIR BAG" and "SEAT BELT PRE-TENSIONER"

INFOID:000000004683988

The Supplemental Restraint System such as "AIR BAG" and "SEAT BELT PRE-TENSIONER", used along with a front seat belt, helps to reduce the risk or severity of injury to the driver and front passenger for certain types of collision. This system includes seat belt switch inputs and dual stage front air bag modules. The SRS system uses the seat belt switches to determine the front air bag deployment, and may only deploy one front air bag, depending on the severity of a collision and whether the front occupants are belted or unbelted. Information necessary to service the system safely is included in the "SRS AIR BAG" and "SEAT BELT" of this Service Manual.

#### **WARNING:**

- To avoid rendering the SRS inoperative, which could increase the risk of personal injury or death in the event of a collision that would result in air bag inflation, all maintenance must be performed by an authorized NISSAN/INFINITI dealer.
- Improper maintenance, including incorrect removal and installation of the SRS, can lead to personal injury caused by unintentional activation of the system. For removal of Spiral Cable and Air Bag Module, see the "SRS AIR BAG".
- Do not use electrical test equipment on any circuit related to the SRS unless instructed to in this Service Manual. SRS wiring harnesses can be identified by yellow and/or orange harnesses or harness connectors.

#### PRECAUTIONS WHEN USING POWER TOOLS (AIR OR ELECTRIC) AND HAMMERS

#### **WARNING:**

- When working near the Air Bag Diagnosis Sensor Unit or other Air Bag System sensors with the ignition ON or engine running, DO NOT use air or electric power tools or strike near the sensor(s) with a hammer. Heavy vibration could activate the sensor(s) and deploy the air bag(s), possibly causing serious injury.
- When using air or electric power tools or hammers, always switch the ignition OFF, disconnect the battery, and wait at least 3 minutes before performing any service.

# COMBINATION METER

< REMOVAL AND INSTALLATION >

## REMOVAL AND INSTALLATION

### COMBINATION METER

#### Exploded View

INFOID:000000004348169

#### REMOVAL

Refer to [IP-12. "Exploded View"](#).

#### DISASSEMBLY

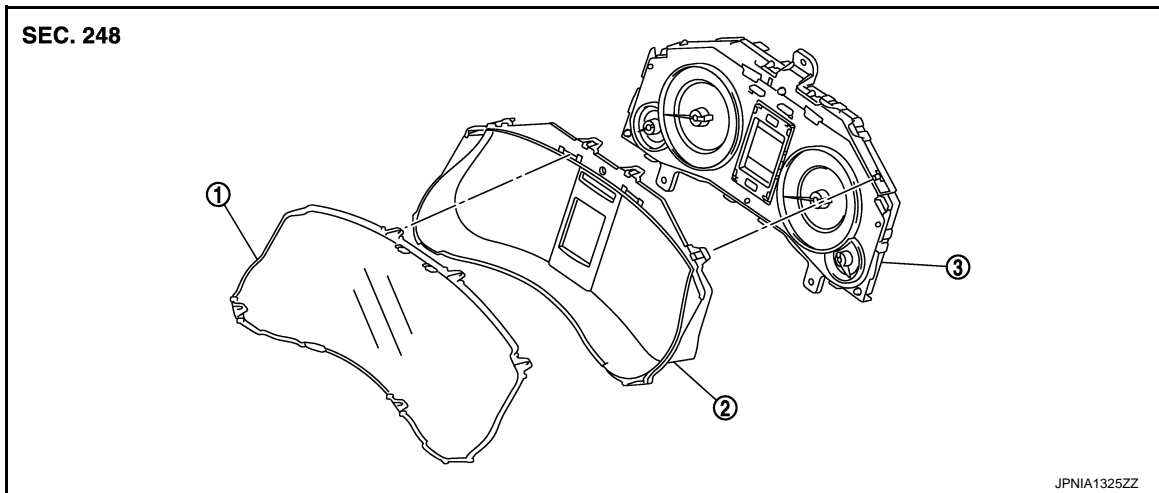

1. Front cover

2. Upper housing

3. Unified meter control unit

#### Removal and Installation

INFOID:000000004348170

#### Removal

1. Remove the cluster lid A. Refer to [IP-13. "Removal and Installation"](#).
2. Remove screws (A) and connector, and then remove combination meter (1).

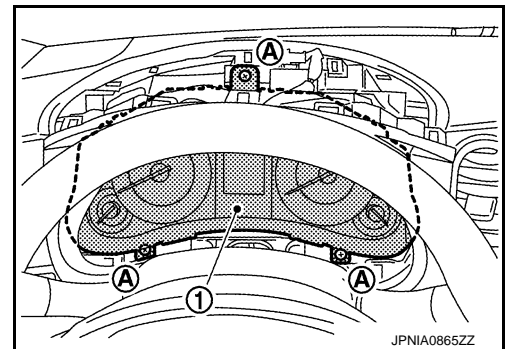

#### Installation

Install in the reverse order of removal.

#### Disassembly and Assembly

INFOID:000000004348171

#### DISASSEMBLY

1. Disengage the tabs to separate the upper housing with the front cover from unified meter control unit.
2. Disengage the tabs to separate the front cover from upper housing.

#### ASSEMBLY

Assemble in the reverse order of disassembly.

# UNIFIED METER AND A/C AMP.

< REMOVAL AND INSTALLATION >

## UNIFIED METER AND A/C AMP.

### Exploded View

INFOID:000000004348172

#### REMOVAL

Refer to [IP-12. "Exploded View"](#).

#### DISASSEMBLY

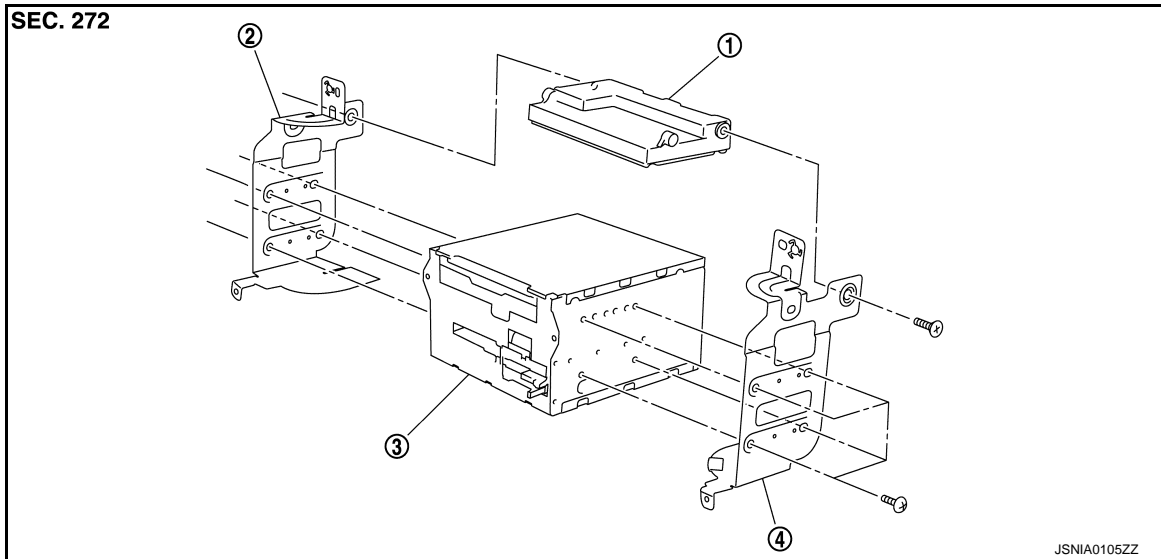

1. Unified meter and A/C amp.
2. Bracket (LH)
3. AV control unit
4. Bracket (RH)

### Removal and Installation

INFOID:000000004348173

#### REMOVAL

1. Remove the display unit.
  - [AV-154. "Exploded View"](#) (BASE AUDIO WITHOUT NAVIGATION)
  - [AV-576. "Exploded View"](#) (BOSE AUDIO WITH NAVIGATION)
2. Remove the unified meter and A/C amp. and AV control unit as an assembly.
3. Remove the bracket screws and remove the unified meter and A/C amp.

#### INSTALLATION

Install in the reverse order of removal.

#### NOTE:

- Unified meter and A/C amp. screws are different from other screws. Never confuse them when installing.
- Since AV control unit connector and unified meter and A/C amp. connector have the same form, be careful not insert them wrongly.

# METER CONTROL SWITCH

< REMOVAL AND INSTALLATION >

## METER CONTROL SWITCH

Exploded View

INFOID:000000004348174

REMOVAL

[IP-12. "Exploded View"](#)

DISASSEMBLY

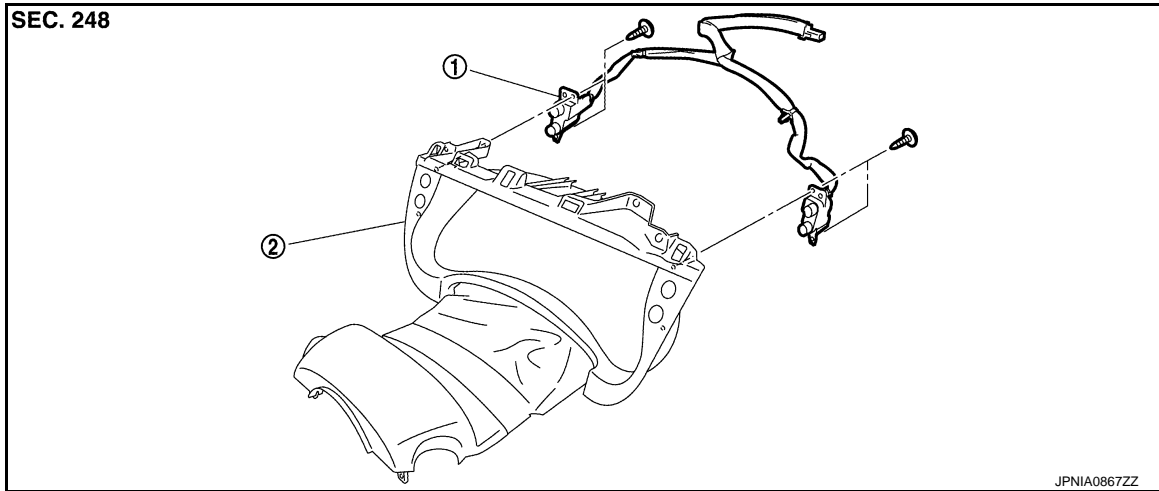

1. Meter control switch

2. Cluster lid A

## Removal and Installation

INFOID:000000004348175

REMOVAL

1. Remove cluster lid A. Refer to [IP-13. "Removal and Installation"](#).
2. Remove screws and remove meter control switch.

INSTALLATION

Install in the reverse order of removal.

A  
B  
C  
D  
E  
F  
G  
H  
I  
J  
K  
L  
M  
N  
O  
P

MWI

# TRIP A/B RESET SWITCH

< REMOVAL AND INSTALLATION >

## TRIP A/B RESET SWITCH

Exploded View

INFOID:000000004348176

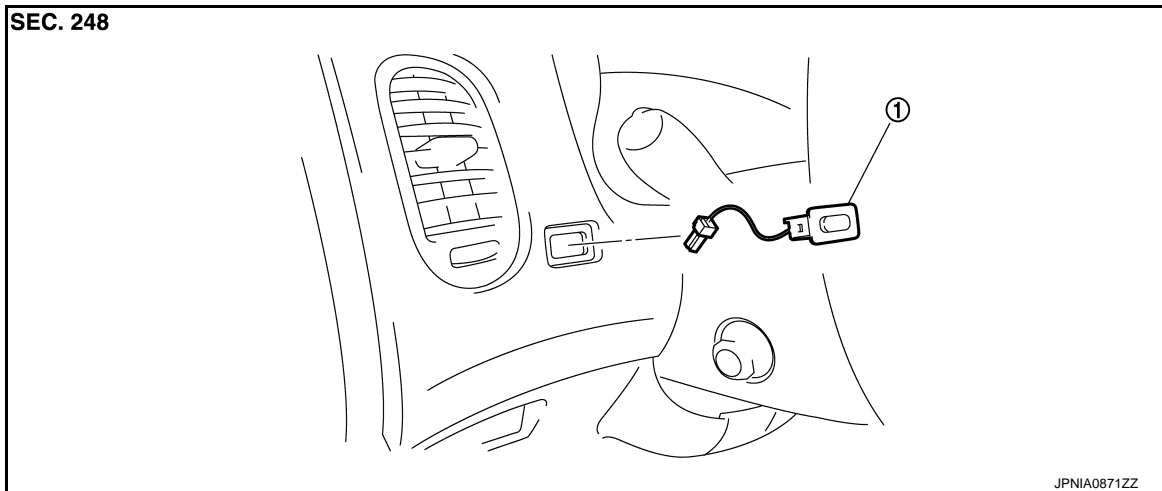

1. Trip A/B reset switch

## Removal and Installation

INFOID:000000004348177

### REMOVAL

1. Remove combination meter. Refer to [MWI-125. "Removal and Installation"](#).
2. Press pawls and remove trip A/B reset switch.

### INSTALLATION

Install in the reverse order of removal.



# COMPASS

< REMOVAL AND INSTALLATION >

## COMPASS

---

### Exploded View

INFOID:000000004348178

Refer to [MIR-101. "Exploded View"](#).

### Removal and Installation

INFOID:000000004348179

Refer to [MIR-101. "Removal and Installation"](#).

A

B

C

D

E

F

G

H

I

J

K

L

M

MWI

O

P

# CLOCK

< REMOVAL AND INSTALLATION >

## CLOCK

### Exploded View

INFOID:000000004348180

#### REMOVAL

Refer to [IP-12. "Exploded View"](#).

#### DISASSEMBLY

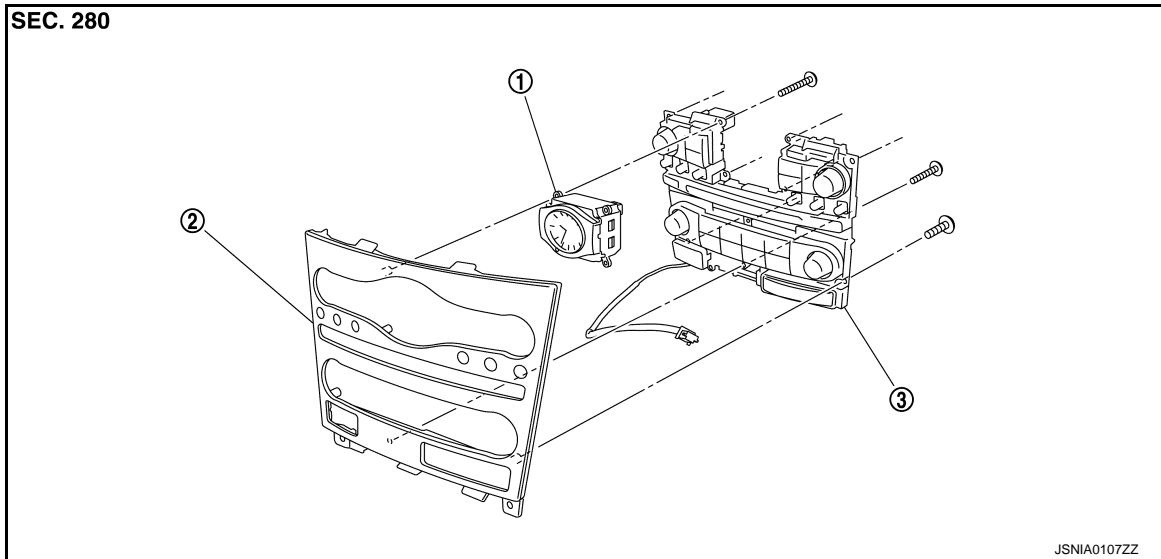

1. Clock

2. Cluster lid C

3. Preset switch

### Removal and Installation

INFOID:000000004348181

#### REMOVAL

1. Remove cluster lid C assembly. Refer to [IP-13. "Removal and Installation"](#).
2. Remove screws (A), (B), (C) and remove clock (1) in conjunction with preset switch (2) from cluster lid C.
3. Disengage the tabs to separate clock.

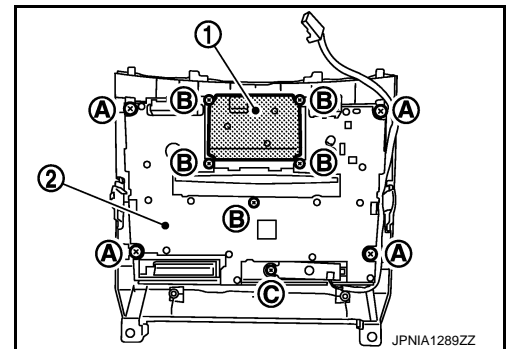

#### INSTALLATION

Install in the reverse order of removal.

#### NOTE:

Never confuse screws when installing.