

# SECTION **SRC**

## SRS AIRBAG CONTROL SYSTEM

A

B

C

D

E

F

G

**SRC**

I

J

K

L

M

N

O

P

### CONTENTS

<p><b>BASIC INSPECTION</b> ..... 5</p> <p><b>DIAGNOSIS AND REPAIR WORK FLOW</b> ..... 5</p> <p style="padding-left: 20px;">Work Flow .....5</p> <p><b>SYSTEM DESCRIPTION</b> ..... 8</p> <p><b>SRS AIR BAG SYSTEM</b> ..... 8</p> <p style="padding-left: 20px;">System Diagram .....8</p> <p style="padding-left: 20px;">System Description .....8</p> <p style="padding-left: 20px;">Component Parts Location .....9</p> <p style="padding-left: 20px;">Component Description ..... 10</p> <p><b>OCCUPANT CLASSIFICATION SYSTEM</b> .....11</p> <p style="padding-left: 20px;">System Diagram ..... 11</p> <p style="padding-left: 20px;">System Description ..... 11</p> <p style="padding-left: 20px;">Component Parts Location ..... 11</p> <p style="padding-left: 20px;">Component Description ..... 12</p> <p><b>PASSENGER SEAT BELT WARNING SYSTEM</b> .....13</p> <p style="padding-left: 20px;">System Diagram ..... 13</p> <p style="padding-left: 20px;">System Description ..... 13</p> <p style="padding-left: 20px;">Component Parts Location ..... 13</p> <p style="padding-left: 20px;">Component Description ..... 14</p> <p><b>DIAGNOSIS SYSTEM (AIRBAG)</b> .....15</p> <p style="padding-left: 20px;">Diagnosis Description ..... 15</p> <p style="padding-left: 20px;">Diagnosis with Air Bag Warning Lamp ..... 15</p> <p style="padding-left: 20px;">CONSULT-III Function ..... 20</p> <p><b>DTC/CIRCUIT DIAGNOSIS</b> .....22</p> <p><b>B1001, B1002, B1003, B1004, B1005 DIAGNOSIS SENSOR UNIT</b> .....22</p> <p style="padding-left: 20px;">Description .....22</p> <p style="padding-left: 20px;">DTC Logic .....22</p> <p style="padding-left: 20px;">Diagnosis Procedure .....22</p> <p><b>B1006, B1007, B1008, B1009, B1010 DIAGNOSIS SENSOR UNIT</b> .....24</p> <p style="padding-left: 20px;">Description .....24</p>	<p style="padding-left: 20px;">DTC Logic .....24</p> <p style="padding-left: 20px;">Diagnosis Procedure .....24</p> <p><b>B1011, B1012, B1013, B1014, B1015 DIAGNOSIS SENSOR UNIT</b> .....26</p> <p style="padding-left: 20px;">Description .....26</p> <p style="padding-left: 20px;">DTC Logic .....26</p> <p style="padding-left: 20px;">Diagnosis Procedure .....26</p> <p><b>B1017, B1020, B1021 OCCUPANT SYSTEM CONTROL UNIT</b> .....28</p> <p style="padding-left: 20px;">Description .....28</p> <p style="padding-left: 20px;">DTC Logic .....28</p> <p style="padding-left: 20px;">Diagnosis Procedure .....28</p> <p><b>B1018 OCCUPANT SYSTEM SENSOR</b> .....30</p> <p style="padding-left: 20px;">Description .....30</p> <p style="padding-left: 20px;">DTC Logic .....30</p> <p style="padding-left: 20px;">Diagnosis Procedure .....30</p> <p><b>B1022 OCCUPANT SYSTEM CONTROL UNIT</b> .....32</p> <p style="padding-left: 20px;">Description .....32</p> <p style="padding-left: 20px;">DTC Logic .....32</p> <p style="padding-left: 20px;">Diagnosis Procedure .....32</p> <p><b>B1023 PASSENGER AIR BAG OFF INDICATOR</b> .....34</p> <p style="padding-left: 20px;">Description .....34</p> <p style="padding-left: 20px;">DTC Logic .....34</p> <p style="padding-left: 20px;">Diagnosis Procedure .....34</p> <p><b>B1025, B1032, B1048 OCCUPANT SYSTEM SENSOR</b> .....36</p> <p style="padding-left: 20px;">Description .....36</p> <p style="padding-left: 20px;">DTC Logic .....36</p> <p style="padding-left: 20px;">Diagnosis Procedure .....36</p> <p><b>B1026, B1027, B1028, B1029, B1030, B1031 DIAGNOSIS SENSOR UNIT</b> .....38</p> <p style="padding-left: 20px;">Description .....38</p> <p style="padding-left: 20px;">DTC Logic .....38</p>
---	--

Diagnosis Procedure .....	38	<b>B1067, B1072 PASSENGER AIR BAG MOD- ULE</b> .....	<b>62</b>
<b>B1033, B1034 CRASH ZONE SENSOR</b> .....	<b>40</b>	Description .....	62
Description .....	40	DTC Logic .....	62
DTC Logic .....	40	Diagnosis Procedure .....	62
Diagnosis Procedure .....	40	<b>B1068, B1073 PASSENGER AIR BAG MOD- ULE</b> .....	<b>64</b>
<b>B1035, B1036 CRASH ZONE SENSOR</b> .....	<b>42</b>	Description .....	64
Description .....	42	DTC Logic .....	64
DTC Logic .....	42	Diagnosis Procedure .....	64
Diagnosis Procedure .....	42	<b>B1074, B1075, B1076, B1077, B1078, B1079 DIAGNOSIS SENSOR UNIT</b> .....	<b>66</b>
<b>B1037, B1039, B1041 CRASH ZONE SEN- SOR</b> .....	<b>44</b>	Description .....	66
Description .....	44	DTC Logic .....	66
DTC Logic .....	44	Diagnosis Procedure .....	66
Diagnosis Procedure .....	44	<b>B1080, B1096 DRIVER AIR BAG MODULE</b> ....	<b>68</b>
<b>B1042, B1043, B1044, B1045, B1046, B1047 DIAGNOSIS SENSOR UNIT</b> .....	<b>46</b>	Description .....	68
Description .....	46	DTC Logic .....	68
DTC Logic .....	46	Diagnosis Procedure .....	68
Diagnosis Procedure .....	46	<b>B1081 SEAT BELT PRE-TENSIONER RH</b> .....	<b>70</b>
<b>B1049, B1054 DRIVER AIR BAG MODULE</b> ....	<b>48</b>	Description .....	70
Description .....	48	DTC Logic .....	70
DTC Logic .....	48	Diagnosis Procedure .....	70
Diagnosis Procedure .....	48	<b>B1082 SEAT BELT PRE-TENSIONER RH</b> .....	<b>72</b>
<b>B1050, B1055 DRIVER AIR BAG MODULE</b> ....	<b>50</b>	Description .....	72
Description .....	50	DTC Logic .....	72
DTC Logic .....	50	Diagnosis Procedure .....	72
Diagnosis Procedure .....	50	<b>B1083 SEAT BELT PRE-TENSIONER RH</b> .....	<b>74</b>
<b>B1051, B1056 DRIVER AIR BAG MODULE</b> ....	<b>52</b>	Description .....	74
Description .....	52	DTC Logic .....	74
DTC Logic .....	52	Diagnosis Procedure .....	74
Diagnosis Procedure .....	52	<b>B1084 SEAT BELT PRE-TENSIONER RH</b> .....	<b>76</b>
<b>B1052, B1057 DRIVER AIR BAG MODULE</b> ....	<b>54</b>	Description .....	76
Description .....	54	DTC Logic .....	76
DTC Logic .....	54	Diagnosis Procedure .....	76
Diagnosis Procedure .....	54	<b>B1086 SEAT BELT PRE-TENSIONER LH</b> .....	<b>78</b>
<b>B1058, B1059, B1060, B1061, B1062, B1063 DIAGNOSIS SENSOR UNIT</b> .....	<b>56</b>	Description .....	78
Description .....	56	DTC Logic .....	78
DTC Logic .....	56	Diagnosis Procedure .....	78
Diagnosis Procedure .....	56	<b>B1087 SEAT BELT PRE-TENSIONER LH</b> .....	<b>80</b>
<b>B1065, B1070 PASSENGER AIR BAG MOD- ULE</b> .....	<b>58</b>	Description .....	80
Description .....	58	DTC Logic .....	80
DTC Logic .....	58	Diagnosis Procedure .....	80
Diagnosis Procedure .....	58	<b>B1088 SEAT BELT PRE-TENSIONER LH</b> .....	<b>82</b>
<b>B1066, B1071 PASSENGER AIR BAG MOD- ULE</b> .....	<b>60</b>	Description .....	82
Description .....	60	DTC Logic .....	82
DTC Logic .....	60	Diagnosis Procedure .....	82
Diagnosis Procedure .....	60	<b>B1089 SEAT BELT PRE-TENSIONER LH</b> .....	<b>84</b>
		Description .....	84
		DTC Logic .....	84

Diagnosis Procedure .....	84	Description .....	108	
<b>B1090, B1091, B1092, B1093, B1094, B1095</b>		DTC Logic .....	108	A
<b>DIAGNOSIS SENSOR UNIT .....</b>	<b>86</b>	Diagnosis Procedure .....	108	
Description .....	86	<b>B1135 SIDE AIR BAG MODULE LH .....</b>	<b>110</b>	B
DTC Logic .....	86	Description .....	110	
Diagnosis Procedure .....	86	DTC Logic .....	110	
<b>B1106, B1107, B1108, B1109, B1110, B1111</b>		Diagnosis Procedure .....	110	C
<b>DIAGNOSIS SENSOR UNIT .....</b>	<b>88</b>	<b>B1136 SIDE AIR BAG MODULE LH .....</b>	<b>112</b>	
Description .....	88	Description .....	112	D
DTC Logic .....	88	DTC Logic .....	112	
Diagnosis Procedure .....	88	Diagnosis Procedure .....	112	
<b>B1113, B1114 SATELLITE SENSOR RH .....</b>	<b>90</b>	<b>B1137 SIDE AIR BAG MODULE LH .....</b>	<b>114</b>	E
Description .....	90	Description .....	114	
DTC Logic .....	90	DTC Logic .....	114	
Diagnosis Procedure .....	90	Diagnosis Procedure .....	114	
<b>B1115, B1116 SATELLITE SENSOR RH .....</b>	<b>92</b>	<b>B1138, B1139, B1140, B1141, B1142, B1143</b>		F
Description .....	92	<b>DIAGNOSIS SENSOR UNIT .....</b>	<b>116</b>	
DTC Logic .....	92	Description .....	116	G
Diagnosis Procedure .....	92	DTC Logic .....	116	
<b>B1118, B1119 SATELLITE SENSOR LH .....</b>	<b>94</b>	Diagnosis Procedure .....	116	
Description .....	94	<b>B1144 DIAGNOSIS SENSOR UNIT .....</b>	<b>118</b>	SRC
DTC Logic .....	94	Description .....	118	
Diagnosis Procedure .....	94	DTC Logic .....	118	
<b>B1120, B1121 SATELLITE SENSOR LH .....</b>	<b>96</b>	Diagnosis Procedure .....	118	
Description .....	96	<b>B1145 CURTAIN AIR BAG MODULE RH .....</b>	<b>119</b>	I
DTC Logic .....	96	Description .....	119	
Diagnosis Procedure .....	96	DTC Logic .....	119	J
<b>B1122, B1123, B1124, B1125, B1126, B1127</b>		Diagnosis Procedure .....	119	
<b>DIAGNOSIS SENSOR UNIT .....</b>	<b>98</b>	<b>B1146 CURTAIN AIR BAG MODULE RH .....</b>	<b>121</b>	K
Description .....	98	Description .....	121	
DTC Logic .....	98	DTC Logic .....	121	
Diagnosis Procedure .....	98	Diagnosis Procedure .....	121	
<b>B1129 SIDE AIR BAG MODULE RH .....</b>	<b>100</b>	<b>B1147 CURTAIN AIR BAG MODULE RH .....</b>	<b>123</b>	L
Description .....	100	Description .....	123	
DTC Logic .....	100	DTC Logic .....	123	
Diagnosis Procedure .....	100	Diagnosis Procedure .....	123	M
<b>B1130 SIDE AIR BAG MODULE RH .....</b>	<b>102</b>	<b>B1148 CURTAIN AIR BAG MODULE RH .....</b>	<b>125</b>	
Description .....	102	Description .....	125	N
DTC Logic .....	102	DTC Logic .....	125	
Diagnosis Procedure .....	102	Diagnosis Procedure .....	125	
<b>B1131 SIDE AIR BAG MODULE RH .....</b>	<b>104</b>	<b>B1150 CURTAIN AIR BAG MODULE LH .....</b>	<b>127</b>	O
Description .....	104	Description .....	127	
DTC Logic .....	104	DTC Logic .....	127	
Diagnosis Procedure .....	104	Diagnosis Procedure .....	127	P
<b>B1132 SIDE AIR BAG MODULE RH .....</b>	<b>106</b>	<b>B1151 CURTAIN AIR BAG MODULE LH .....</b>	<b>129</b>	
Description .....	106	Description .....	129	
DTC Logic .....	106	DTC Logic .....	129	
Diagnosis Procedure .....	106	Diagnosis Procedure .....	129	
<b>B1134 SIDE AIR BAG MODULE LH .....</b>	<b>108</b>	<b>B1152 CURTAIN AIR BAG MODULE LH .....</b>	<b>131</b>	
		Description .....	131	

DTC Logic .....	131	<b>B1212, B1213, B1214 SATELLITE SENSOR</b>	
Diagnosis Procedure .....	131	<b>RH .....</b>	<b>146</b>
<b>B1153 CURTAIN AIR BAG MODULE LH .....</b>	<b>133</b>	Description .....	146
Description .....	133	DTC Logic .....	146
DTC Logic .....	133	Diagnosis Procedure .....	146
Diagnosis Procedure .....	133	<b>B1215, B1216, B1217 SATELLITE SENSOR</b>	
<b>B1154, B1155, B1156, B1157, B1158, B1159</b>		<b>LH .....</b>	<b>148</b>
<b>DIAGNOSIS SENSOR UNIT .....</b>	<b>135</b>	Description .....	148
Description .....	135	DTC Logic .....	148
DTC Logic .....	135	Diagnosis Procedure .....	148
Diagnosis Procedure .....	135	<b>B1218, B1219, B1220, B1221, B1222, B1223</b>	
<b>B1170, B1171, B1172, B1173, B1174, B1175</b>		<b>DIAGNOSIS SENSOR UNIT .....</b>	<b>150</b>
<b>DIAGNOSIS SENSOR UNIT .....</b>	<b>137</b>	Description .....	150
Description .....	137	DTC Logic .....	150
DTC Logic .....	137	Diagnosis Procedure .....	150
Diagnosis Procedure .....	137	<b>ECU DIAGNOSIS INFORMATION .....</b>	<b>152</b>
<b>B1186, B1187, B1188, B1189, B1190, B1191</b>		<b>DIAGNOSIS SENSOR UNIT .....</b>	<b>152</b>
<b>DIAGNOSIS SENSOR UNIT .....</b>	<b>139</b>	DTC Index .....	152
Description .....	139	Wiring Diagram - SRS AIR BAG CONTROL SYS-	
DTC Logic .....	139	TEM - .....	156
Diagnosis Procedure .....	139	<b>SYMPTOM DIAGNOSIS .....</b>	<b>164</b>
<b>B1202, B1203, B1204, B1205, B1206, B1207</b>		<b>SRS AIR BAG WARNING LAMP DOES NOT</b>	
<b>DIAGNOSIS SENSOR UNIT .....</b>	<b>141</b>	<b>TURN OFF .....</b>	<b>164</b>
Description .....	141	Diagnosis Procedure .....	164
DTC Logic .....	141	<b>SRS AIR BAG WARNING LAMP DOES NOT</b>	
Diagnosis Procedure .....	141	<b>TURN ON .....</b>	<b>165</b>
<b>B1209 FRONTAL COLLISION DETECTION .</b>	<b>143</b>	Diagnosis Procedure .....	165
Description .....	143	<b>PASSENGER SEAT BELT WARNING SYS-</b>	
DTC Logic .....	143	<b>TEM .....</b>	<b>166</b>
Diagnosis Procedure .....	143	Diagnosis Procedure .....	166
<b>B1210 SIDE COLLISION DETECTION .....</b>	<b>144</b>	<b>PRECAUTION .....</b>	<b>167</b>
Description .....	144	<b>PRECAUTIONS .....</b>	<b>167</b>
DTC Logic .....	144	Precaution for Supplemental Restraint System	
Diagnosis Procedure .....	144	(SRS) "AIR BAG" and "SEAT BELT PRE-TEN-	
<b>B1211 ROLLOVER DETECTION .....</b>	<b>145</b>	SIONER" .....	167
Description .....	145	Service .....	167
DTC Logic .....	145	Occupant Classification System Precaution .....	167
Diagnosis Procedure .....	145		

# DIAGNOSIS AND REPAIR WORK FLOW

< BASIC INSPECTION >

## BASIC INSPECTION

### DIAGNOSIS AND REPAIR WORK FLOW

Work Flow

INFOID:000000005531116

OVERALL SEQUENCE

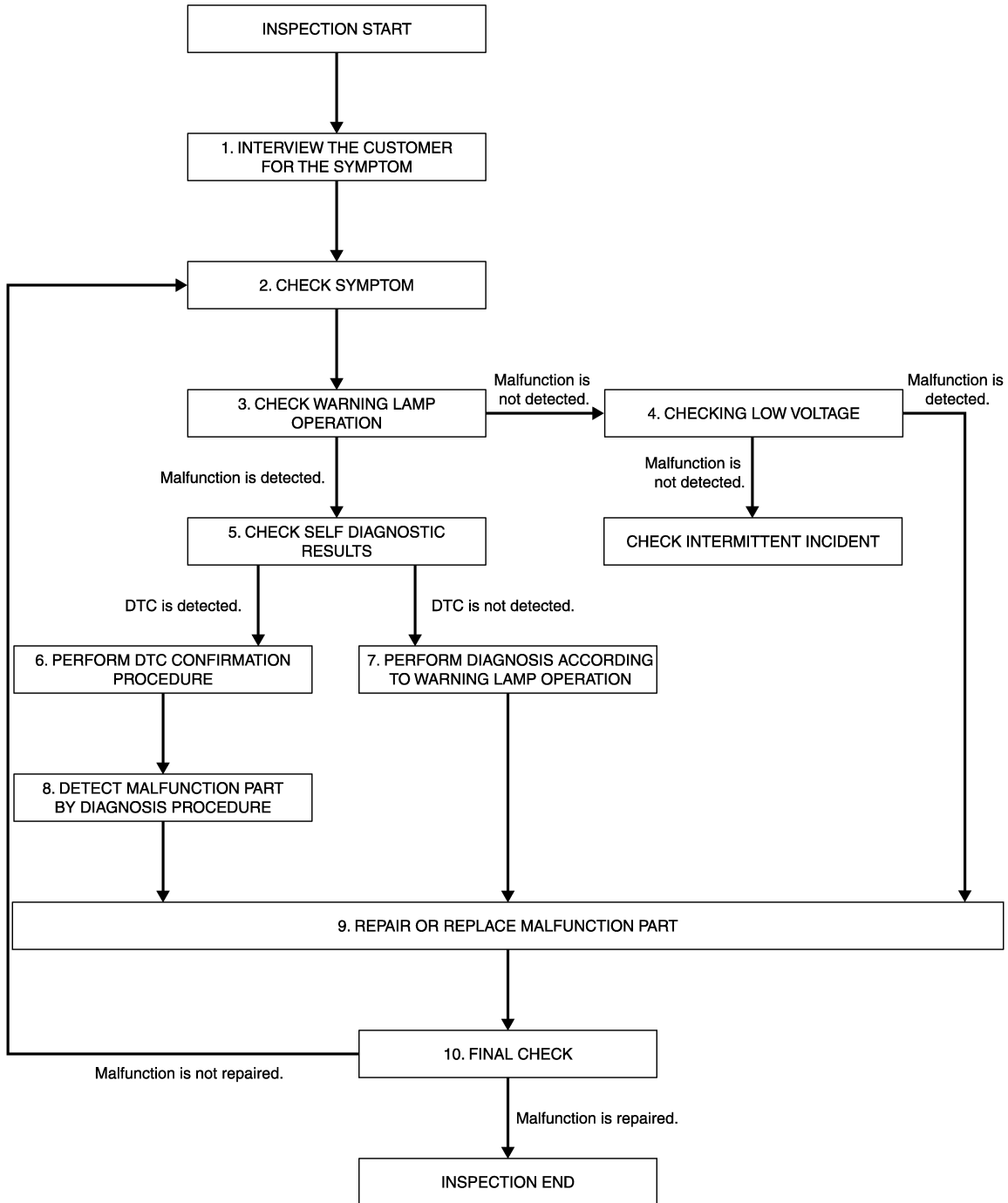

SRC

JMHIA1324GB

DETAILED FLOW

# DIAGNOSIS AND REPAIR WORK FLOW

< BASIC INSPECTION >

---

## 1. INTERVIEW THE CUSTOMER FOR THE SYMPTOM

---

Interview the customer for the symptom (the condition and the environment when the incident/malfunction occurs).

>> GO TO 2.

## 2. CHECK SYMPTOM

---

Check the symptom from the customer information.

>> GO TO 3.

## 3. CHECK WARNING LAMP OPERATION

---

Check air bag warning lamp operation in the user mode. Refer to [SRC-15, "Diagnosis with Air Bag Warning Lamp"](#).

Are any malfunction detected?

YES >> GO TO 5.

NO >> GO TO 4.

## 4. CHECK LOW VOLTAGE

---

Check low voltage. Refer to [PG-3, "How to Handle Battery"](#).

Are any malfunction detected?

YES >> GO TO 9.

NO >> Check intermittent incident. Refer to [GI-37, "Intermittent Incident"](#).

## 5. CHECK SELF DIAGNOSTIC RESULTS

---

Check self diagnostic result with CONSULT-III or diagnosis mode.

If it is impossible to switch to diagnosis mode, follow the same procedure that DTC is not detected.

### NOTE:

Perform the following procedure if DTC is detected.

- Record DTC (Print them out with CONSULT-III.)
- Erase self diagnostic result.
- Study the relationship between the malfunction that DTC or air bag warning lamp indicates and the symptom that the customer describes.
- Check related service bulletins for information.

Is DTC detected?

YES >> GO TO 6.

NO >> GO TO 7.

## 6. PERFORM DTC CONFIRMATION PROCEDURE

---

Perform DTC CONFIRMATION PROCEDURE for the DTC.

>> GO TO 8.

## 7. PERFORM DIAGNOSIS ACCORDING TO WARNING LAMP OPERATION

---

1. Check air bag warning lamp operation in the user mode. Refer to [SRC-15, "Diagnosis with Air Bag Warning Lamp"](#).
2. Perform Diagnosis Procedure for the air bag warning lamp operation. Refer to [SRC-15, "Diagnosis with Air Bag Warning Lamp"](#) (USER MODE).

>> GO TO 9.

## 8. DETECT MALFUNCTIONING PART BY DIAGNOSTIC PROCEDURE

---

Inspect according to Diagnostic Procedure of the DTC.

>> GO TO 9.

# DIAGNOSIS AND REPAIR WORK FLOW

< BASIC INSPECTION >

---

## 9.REPAIR OR REPLACE THE MALFUNCTION PART

---

Repair or replace the malfunctioning part.

>> GO TO 10.

## 10.FINAL CHECK

---

Check self diagnostic result and air bag warning lamp operation in the user mode.

Is the malfunction repaired?

YES >> INSPECTION END  
NO >> GO TO 2.

A  
B  
C  
D  
E  
F  
G  
I  
J  
K  
L  
M  
N  
O  
P

SRC

# SRS AIR BAG SYSTEM

< SYSTEM DESCRIPTION >

## SYSTEM DESCRIPTION

### SRS AIR BAG SYSTEM

#### System Diagram

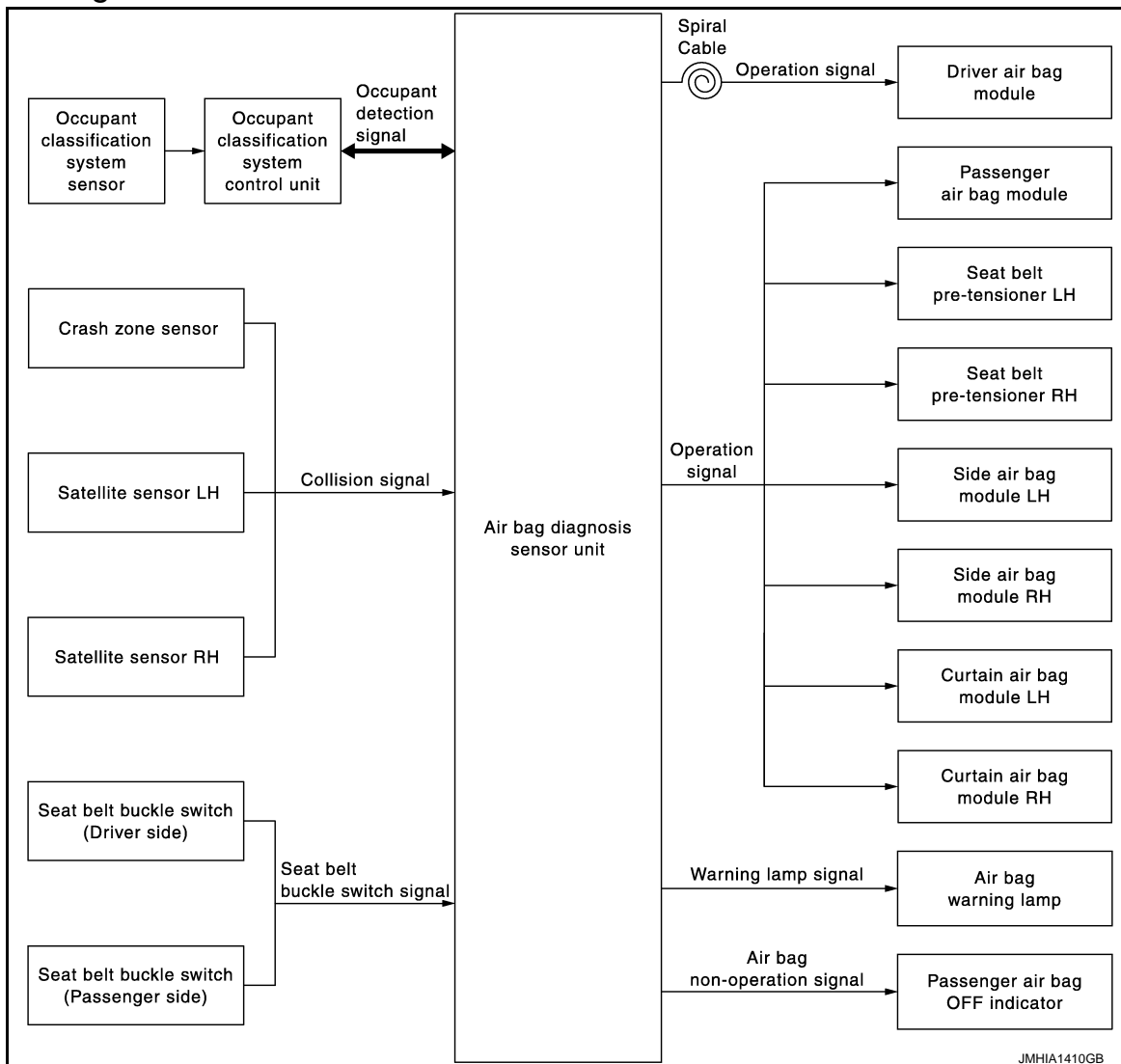

#### System Description

INFOID:000000005174154

Supplemental Restraint System (SRS) activates air bag module and seat belt pre-tensioner when it detects a frontal collision or a side collision that is more than the specified limit. Together with other safety devices, it reduces the impact that occupant receives when vehicle collision occurs.

Air bag sensor unit supplies power supply to air bag module and pre-tensioner seat belt when deceleration that is more than the specified limit is detected by G sensor in air bag diagnosis sensor unit, crash zone sensor, or satellite sensor. Air bag module is composed of electric igniter (squib), filter, pyrotechnic material, and gas generating material. When air bag module receives a signal from air bag sensor unit, air bag module ignites pyrotechnic material using electric igniter (squib) so that gas generating material generates high temperature nitrogen gas. The gas through filter activates air bag and seat belt pre-tensioner.

This SRS Air Bag System has the following functions.

- Detects a collision and supplies the energy for deploying air bag and seat belt pre-tensioner.
- Detects electrical malfunction in SRS Air Bag System and Seat Belt Pre-tensioner System, records malfunction code, and blinking air bag warning lamp.
- Detects and records the deployment of air bag and seat belt pre-tensioner, and turns ON air bag warning lamp.
- Indicates malfunctioning portion with blinking times of air bag warning lamp in diagnosis mode.



# SRS AIR BAG SYSTEM

## < SYSTEM DESCRIPTION >

- Indicates the malfunction record by CONSULT-III.
- Suppress the deployment of front passenger air bag when front passenger seat is empty or is occupied by a child or a child-seat.
- When passenger seat is occupied by a child or a child seat, turns ON front passenger air bag OFF indicator.
- When judges that passenger seat is occupied by an adult or a child and passenger seat belt is not fastened, turns ON seat belt warning lamp.

## COLLISION MODE

- The operation of supplemental restraint system is different depending on the collision modes applications. For example, the driver air bag module, front passenger air bag module and front seat belt pre-tensioner are activated in a frontal collision but not in a side collision.
- SRS configurations that are activated for some collision modes are as per the following.

x: Apply, —: Not apply

SRS configuration	Frontal collision	Left side collision	Right side collision	Roll over
Driver air bag module.	x	—	—	—
Front passenger air bag module.	x	—	—	—
Front LH seat belt pre-tensioner.	x	—	—	x
Front RH seat belt pre-tensioner.	x	—	—	x
Front LH side air bag module.	—	x	—	—
Front RH side air bag module.	—	—	x	—
LH side curtain air bag module.	—	x	—	x
RH side curtain air bag module.	—	—	x	x

## Component Parts Location

INFOID:000000005174155

SRC

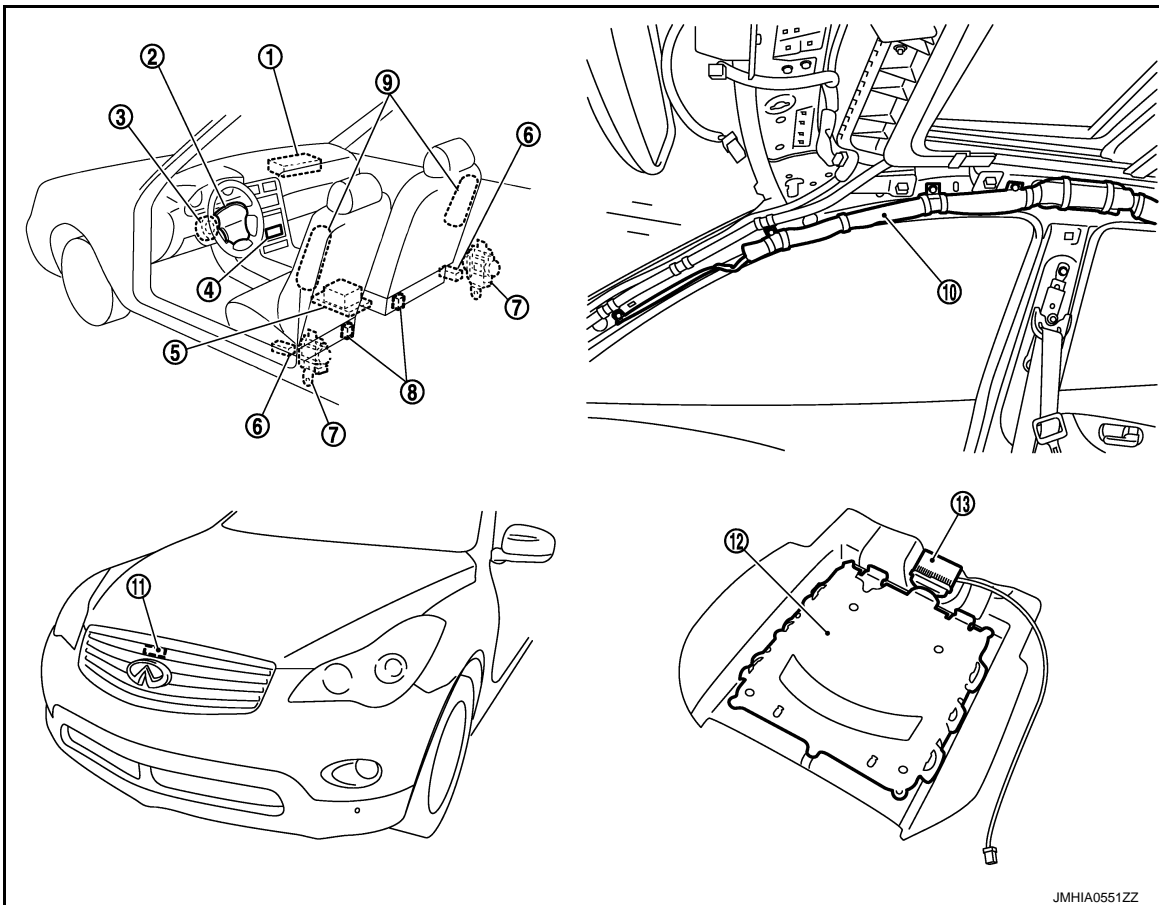

JMHIA0551ZZ

# SRS AIR BAG SYSTEM

## < SYSTEM DESCRIPTION >

- |   |   |  |
|---|---|--|
| 1. Front passenger air bag module               | 2. Driver air bag module                                | 3. Combination switch (Spiral cable)               |
| 4. Front passenger air bag OFF indicator        | 5. Air bag diagnosis sensor unit                        | 6. Satellite sensor (LH/RH)                        |
| 7. Front seat belt pre-tensioner (LH/RH)        | 8. Seat belt buckle switch (Driver side/Passenger side) | 9. Front side air bag module (LH/RH)               |
| 10. Side curtain air bag module                 | 11. Crash zone sensor                                   | 12. Occupant Classification System seat sensor mat |
| 13. Occupant Classification System control unit |   |  |

## Component Description

INFOID:000000005174156

Component	Function
Air bag diagnosis sensor unit	Detects a collision and supplies power supply for deployment to air bag module and pre-tensioner seat belt.
Air bag module <ul style="list-style-type: none"> <li>• Driver</li> <li>• Passenger</li> <li>• Front side</li> <li>• Side curtain</li> </ul>	Receives signal from air bag diagnosis sensor unit and deploys air bag.
Front seat belt pre-tensioner	Receives signal from air bag diagnosis sensor unit and deploys pre-tensioner seat belt.
Seat belt buckle switch	Controls deployment timing depending on the seat belt condition that is fastened or unfastened.
Crash zone sensor	Transmits signal to air bag diagnosis sensor unit when a frontal collision occurs.
Satellite sensor (LH/RH)	Transmits signal to air bag diagnosis sensor unit when a side collision occurs.
Occupant Classification System	Detects front passenger seat occupant and judges whether or not deploys front passenger seat air bag.
Combination meter (air bag warning lamp)	Indicates air bag malfunctioning and deployment by blinking and illuminating air bag warning lamp.
Front passenger air bag OFF indicator	Indicates whether or not front passenger air bag is in activation mode subject to the judgement by Occupant Classification System.
Combination switch (spiral cable)	Supplies power supply to driver air bag module on steering wheel.

# OCCUPANT CLASSIFICATION SYSTEM

< SYSTEM DESCRIPTION >

## OCCUPANT CLASSIFICATION SYSTEM

### System Diagram

INFOID:000000005174157

### OCCUPANT CLASSIFICATION SYSTEM

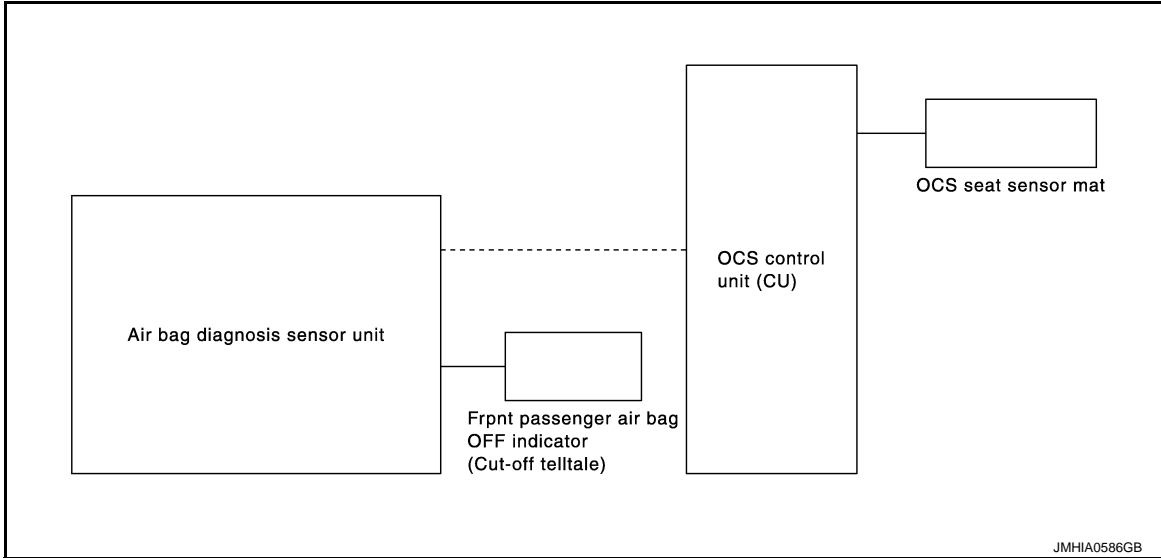

### System Description

INFOID:000000005174158

SRC

#### THIS OCCUPANT CLASSIFICATION SYSTEM HAS THE FOLLOWING FUNCTIONS

1. Suppress the deployment of front passenger air bag when front passenger seat is empty, or when occupied by child and child-seat. Turns ON front passenger air bag OFF indicator when front passenger seat is occupied by child-seat and child.
2. Indicates malfunction portion with blinking times of air bag warning lamp in diagnosis mode.
3. Indicates the malfunctioning record by CONSULT-III.

**NOTE:**

Operation of air bag diagnosis sensor unit when air bag diagnosis sensor unit receives information from Occupant Classification System.

Status (front passenger seat)	Passenger air bag	Front passenger air bag OFF indicator	Air bag warning lamp	Seat belt warning lamp (when front passenger seat is unbuckled)
Empty	Suppress	OFF	OFF	OFF
Child/ child-seat	Suppress	ON	OFF	ON
Adult	Enable to deploy	OFF	OFF	ON
Malfunction	Suppress	ON	Blinking	OFF

### Component Parts Location

INFOID:000000005174159

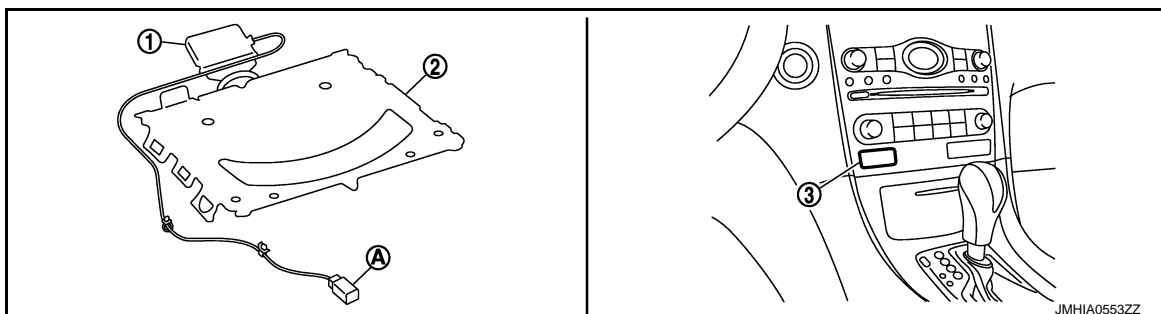

# OCCUPANT CLASSIFICATION SYSTEM

## < SYSTEM DESCRIPTION >

1. Occupant classification system control unit
  2. Occupant Classification System seat sensor mat
  3. Front passenger air bag OFF indicator
- A. Occupant classification system control unit harness connector

## Component Description

INFOID:000000005174160

Component parts	Outline of function
Seat sensor mat	Detects if the passenger seat is empty or occupied
Occupant Classification System control unit	Transmits the passenger seat status (occupied or empty) to air bag diagnosis sensor unit
Front passenger air bag OFF indicator	Turns the front passenger air bag OFF indicator lamp ON when the front passenger seat is occupied by a child or a child-seat
Air bag diagnosis sensor unit	Performs the deploy judgement of passenger air bag based on the information from Occupant Classification System control unit

# PASSENGER SEAT BELT WARNING SYSTEM

< SYSTEM DESCRIPTION >

## PASSENGER SEAT BELT WARNING SYSTEM

### System Diagram

INFOID:000000005174161

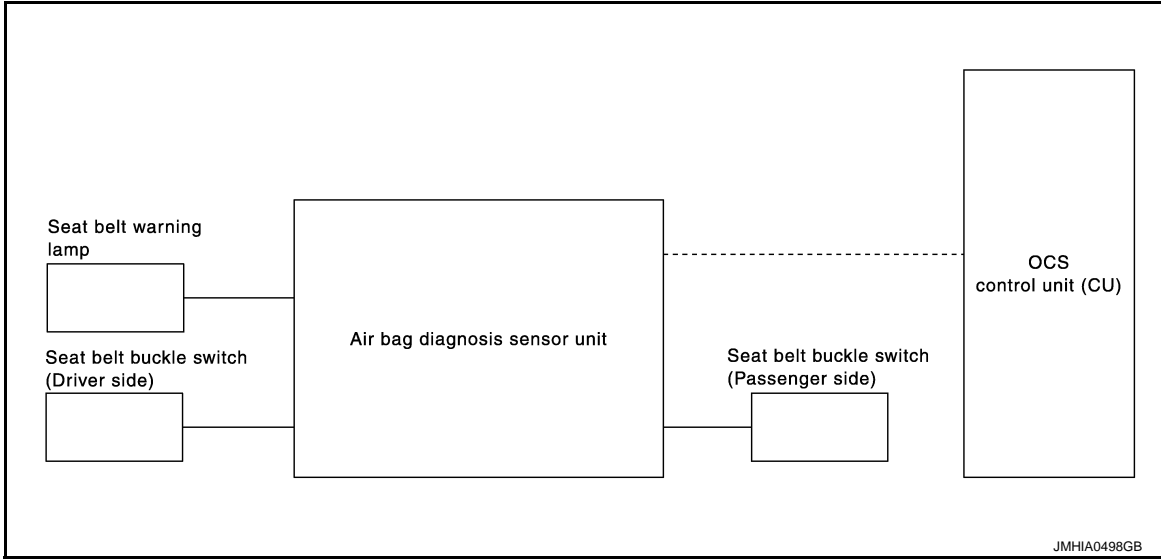

JMHIA0498GB

### System Description

INFOID:000000005174162

- Turns ON seat belt warning lamp, when the Occupant Classification System judges adult or child in the front passenger seat and the passenger seat belt buckle switch is OFF.
- Operation of air bag diagnosis sensor unit when air bag diagnosis sensor unit receives information from Occupant Classification System.
- In addition, seat belt warning lamp illuminates, when the driver side seat belt is not fasten. This does not relate to the air bag diagnosis sensor unit.

SRC

Status (front passenger seat)	Seat belt warning lamp (When front passenger seat is unbuckled)
Empty	OFF
Child/ child-seat	ON
Adult	ON
Malfunction	OFF

### Component Parts Location

INFOID:000000005174163

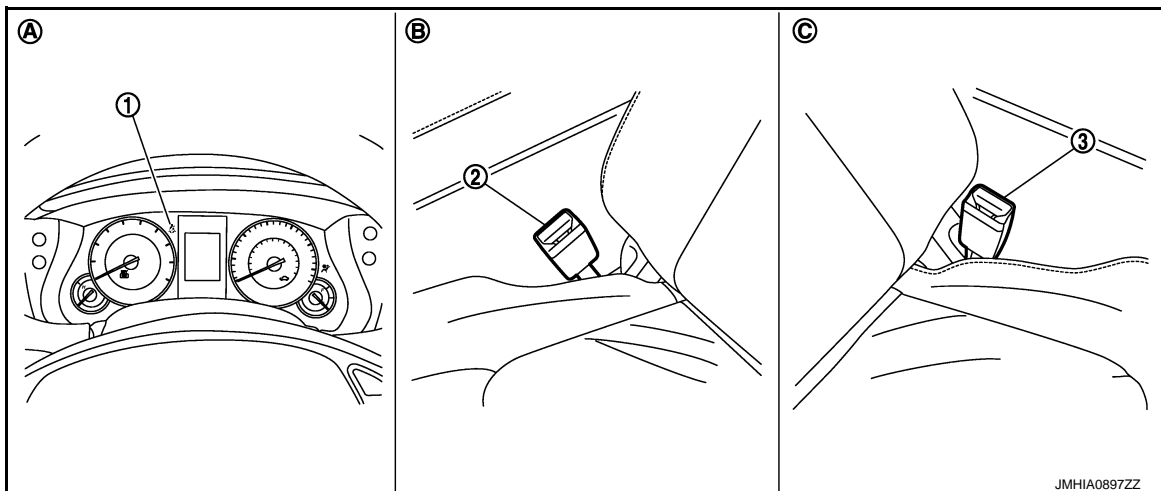

JMHIA0897ZZ

# PASSENGER SEAT BELT WARNING SYSTEM

## < SYSTEM DESCRIPTION >

- |   |  |   |
|---|--|---|
| 1. Combination meter (Seat belt warning lamp) | 2. Seat belt buckle switch (Driver side) | 3. Seat belt buckle switch (Passenger side) |
| A. Combination meter                          | B. Driver side                           | C. Passenger side                           |

## Component Description

INFOID:000000005174164

Component parts	Outline of function
Seat belt buckle switch (Driver side)	Detects if the seat belt buckle switch (driver side) is fastened or unfastened
Seat belt buckle switch (Passenger side)	Detects if the seat belt buckle switch (passenger side) is fastened or unfastened
Seat belt warning lamp	Turns the seat belt warning lamp ON when the seat belt is unfastened
Occupant Classification System control unit	Judges the passenger seat condition based on the information from Occupant Classification System control unit
Seat sensor mat	Detects if the passenger seat is empty or occupied
Air bag diagnosis sensor unit	Turns ON seat belt warning lamp based on the information from Occupant Classification System control unit
Front passenger air bag OFF indicator	Turns the front passenger air bag OFF indicator lamp ON when the front passenger seat is occupied by a child or a child seat

# DIAGNOSIS SYSTEM (AIRBAG)

< SYSTEM DESCRIPTION >

## DIAGNOSIS SYSTEM (AIRBAG)

### Diagnosis Description

INFOID:000000005174165

#### CAUTION:

- Never use electrical test equipment on any circuit related to the SRS unless instructed in this Service Manual. SRS wiring harnesses can be identified by yellow and/or orange harnesses or harness connectors.
- Never repair, splice or modify the SRS wiring harness. If the harness is damaged, replace it with a new one.
- Keep ground portion clean.

### DIAGNOSIS FUNCTION

- The SRS self-diagnosis results can be read by using air bag warning lamp and/or CONSULT-III.
- The user mode is exclusively prepared for the customer (driver). This mode warns the driver of a system malfunction through the operation of the air bag warning lamp.
- The diagnosis mode allows the technician to locate and inspect the malfunctioning part.
- The mode applications for the air bag warning lamp and CONSULT-III are as per the following.

	User mode	Diagnosis mode	Display type
Air bag warning lamp	X	X	ON-OFF operation
CONSULT-III	—	X	Monitoring

x: Application, —: Not application

### HOW TO PERFORM TROUBLE DIAGNOSIS FOR QUICK AND ACCURATE REPAIR

A good understanding of the malfunction conditions can make troubleshooting faster and more accurate. In general, each customer feels differently about a malfunction. It is important to fully understand the symptoms or conditions for a customer complaint.

Information from Customer.

- WHAT..... Vehicle model.
- WHEN..... Date, Frequencies.
- WHERE..... Road conditions.
- HOW..... Operating conditions, Symptoms.

Preliminary Check.

- Check that the following parts are in good order.
- Battery (Refer to [PG-3, "How to Handle Battery"](#)).
- Fuse (Refer to [PG-104, "Fuse"](#)).
- System component-to-harness connections.

### Diagnosis with Air Bag Warning Lamp

INFOID:000000005174166

### SELF DIAGNOSIS FUNCTION

There are two self diagnosis functions with air bag warning lamp per the following items.

- USER MODE
- DIAGNOSIS MODE

A  
B  
C  
D  
E  
F  
G  
I  
J  
K  
L  
M  
N  
O  
P

SRC

# DIAGNOSIS SYSTEM (AIRBAG)

## < SYSTEM DESCRIPTION >

### HOW TO CHANGE SELF DIAGNOSIS MODE WITHOUT CONSULT-III

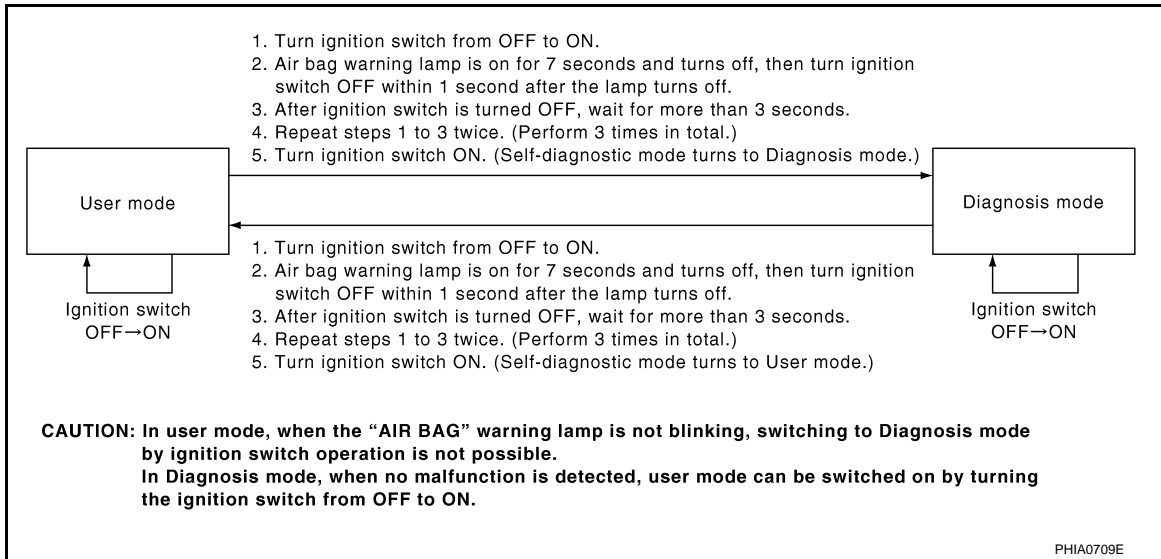

### USER MODE

In USER MODE, air bag warning lamp on combination meter blinks when a malfunction is detected and warns the customer (driver).

#### How to Read Air Bag Warning Lamp

1. Turn the ignition switch from OFF to ON, and check that the air bag warning lamp blinks.
2. Compare the air bag warning lamp blinking pattern with the examples.

#### Air Bag Warning Lamp Examples

Air bag warning lamp operation (user mode)	SRS condition	Reference item
<p>SHIA0011E</p>	<ul style="list-style-type: none"> <li>• No malfunction is detected</li> <li>• No further action is necessary</li> </ul>	—
<p>SHIA0012E</p>	<ul style="list-style-type: none"> <li>• The system is malfunctioning</li> <li>• Battery voltage is low (less than 9 V)</li> </ul>	Go to <a href="#">SRC-20, "CONSULT-III Function"</a>



# DIAGNOSIS SYSTEM (AIRBAG)

## < SYSTEM DESCRIPTION >

Air bag warning lamp operation (user mode)	SRS condition	Reference item
<p>SHIA0013E</p>	<ul style="list-style-type: none"> <li>Air bag is deployed</li> <li>Seat belt pre-tensioner is deployed</li> </ul>	Go to <a href="#">SRC-143, "Diagnosis Procedure"</a> or <a href="#">SRC-144, "Diagnosis Procedure"</a>
	<ul style="list-style-type: none"> <li>Air bag diagnosis sensor unit is malfunctioning</li> <li>Air bag power supply circuit is malfunctioning</li> <li>Air bag warning lamp circuit is malfunctioning</li> </ul>	Go to <a href="#">SRC-164, "Diagnosis Procedure"</a>
<p>SHIA0014E</p>	<ul style="list-style-type: none"> <li>Air bag diagnosis sensor unit is malfunctioning</li> <li>Air bag warning lamp circuit is malfunctioning</li> </ul>	Go to <a href="#">SRC-165, "Diagnosis Procedure"</a>

## DIAGNOSIS MODE

The diagnosis mode can only be switched when a malfunction is detected in the user mode. Malfunctioning system is indicated according to blinking pattern of air bag warning lamp.

### How to Read Air Bag Warning Lamp

- Follow the procedures of "HOW TO CHANGE SELF-DIAGNOSIS MODE WITHOUT CONSULT-III", and switch to the diagnosis mode.
- Turn ignition switch ON. Check the blinking pattern of air bag warning lamp. There are 2 blinking patterns for the air bag warning lamp as per the following items.
  - Front air bag system: 3 second blink followed by a 0.5 second blink repeated.
  - Side air bag system: Two 1.5 second blinks followed by a 0.5 second blink repeated.

### Front air bag system

Number of 0.5 second blinks	Malfunctioning items	Blinking pattern
0	<ul style="list-style-type: none"> <li>Self-diagnosis result is not deleted</li> <li>Intermittent malfunction has been detect in the past</li> </ul>	Refer to the following items <ul style="list-style-type: none"> <li>How to Erase Self Diagnosis Result</li> <li><a href="#">SRC-20, "CONSULT-III Function"</a></li> </ul>
1	Front LH seat belt pre-tensioner	Refer to the following items <ul style="list-style-type: none"> <li><a href="#">SRC-78, "DTC Logic"</a></li> <li><a href="#">SRC-80, "DTC Logic"</a></li> <li><a href="#">SRC-82, "DTC Logic"</a></li> <li><a href="#">SRC-84, "DTC Logic"</a></li> </ul>
2	Driver air bag module	Refer to the following items <ul style="list-style-type: none"> <li><a href="#">SRC-48, "DTC Logic"</a></li> <li><a href="#">SRC-50, "DTC Logic"</a></li> <li><a href="#">SRC-52, "DTC Logic"</a></li> <li><a href="#">SRC-54, "DTC Logic"</a></li> <li><a href="#">SRC-68, "DTC Logic"</a></li> </ul>
3	Front RH Seat belt pre-tensioner	Refer to the following items <ul style="list-style-type: none"> <li><a href="#">SRC-70, "DTC Logic"</a></li> <li><a href="#">SRC-72, "DTC Logic"</a></li> <li><a href="#">SRC-74, "DTC Logic"</a></li> <li><a href="#">SRC-76, "DTC Logic"</a></li> </ul>

## DIAGNOSIS SYSTEM (AIRBAG)

### < SYSTEM DESCRIPTION >

Number of 0.5 second blinks	Malfunctioning items	Blinking pattern
5	Occupant Classification System control unit	Refer to the following items <ul style="list-style-type: none"> <li>• <a href="#">SRC-28, "DTC Logic"</a></li> <li>• <a href="#">SRC-30, "DTC Logic"</a></li> <li>• <a href="#">SRC-32, "DTC Logic"</a></li> <li>• <a href="#">SRC-36, "DTC Logic"</a></li> </ul>
6	Crash zone sensor	Refer to the following items <ul style="list-style-type: none"> <li>• <a href="#">SRC-40, "DTC Logic"</a></li> <li>• <a href="#">SRC-42, "DTC Logic"</a></li> <li>• <a href="#">SRC-44, "DTC Logic"</a></li> </ul>
7	Air bag diagnosis sensor unit	Refer to the following items <ul style="list-style-type: none"> <li>• <a href="#">SRC-22, "DTC Logic"</a></li> <li>• <a href="#">SRC-24, "DTC Logic"</a></li> <li>• <a href="#">SRC-26, "DTC Logic"</a></li> <li>• <a href="#">SRC-38, "DTC Logic"</a></li> <li>• <a href="#">SRC-46, "DTC Logic"</a></li> <li>• <a href="#">SRC-56, "DTC Logic"</a></li> <li>• <a href="#">SRC-66, "DTC Logic"</a></li> <li>• <a href="#">SRC-86, "DTC Logic"</a></li> <li>• <a href="#">SRC-88, "DTC Logic"</a></li> <li>• <a href="#">SRC-98, "DTC Logic"</a></li> <li>• <a href="#">SRC-116, "DTC Logic"</a></li> <li>• <a href="#">SRC-118, "DTC Logic"</a></li> <li>• <a href="#">SRC-135, "DTC Logic"</a></li> <li>• <a href="#">SRC-137, "DTC Logic"</a></li> <li>• <a href="#">SRC-139, "DTC Logic"</a></li> <li>• <a href="#">SRC-141, "DTC Logic"</a></li> <li>• <a href="#">SRC-150, "DTC Logic"</a></li> </ul>
8	Front passenger air bag module	Refer to the following items <ul style="list-style-type: none"> <li>• <a href="#">SRC-58, "DTC Logic"</a></li> <li>• <a href="#">SRC-60, "DTC Logic"</a></li> <li>• <a href="#">SRC-62, "DTC Logic"</a></li> <li>• <a href="#">SRC-64, "DTC Logic"</a></li> </ul>
11	Front passenger air bag OFF indicator	Refer to <a href="#">SRC-34, "DTC Logic"</a> .
17	Air bag diagnosis sensor unit	Refer to <a href="#">SRC-118, "DTC Logic"</a>

#### Side air bag system

Number of 0.5-second blinks	Malfunctioning items	Blinking pattern
1	Front RH side air bag module	Refer to the following items <ul style="list-style-type: none"> <li>• <a href="#">SRC-100, "DTC Logic"</a></li> <li>• <a href="#">SRC-102, "DTC Logic"</a></li> <li>• <a href="#">SRC-104, "DTC Logic"</a></li> <li>• <a href="#">SRC-106, "DTC Logic"</a></li> </ul>
2	Front LH side air bag module	Refer to the following items <ul style="list-style-type: none"> <li>• <a href="#">SRC-108, "DTC Logic"</a></li> <li>• <a href="#">SRC-110, "DTC Logic"</a></li> <li>• <a href="#">SRC-112, "DTC Logic"</a></li> <li>• <a href="#">SRC-114, "DTC Logic"</a></li> </ul>
3	RH satellite sensor	Refer to the following items <ul style="list-style-type: none"> <li>• <a href="#">SRC-90, "DTC Logic"</a></li> <li>• <a href="#">SRC-92, "DTC Logic"</a></li> <li>• <a href="#">SRC-146, "DTC Logic"</a></li> </ul>
4	LH satellite sensor	Refer to the following items <ul style="list-style-type: none"> <li>• <a href="#">SRC-94, "DTC Logic"</a></li> <li>• <a href="#">SRC-96, "DTC Logic"</a></li> <li>• <a href="#">SRC-148, "DTC Logic"</a></li> </ul>

# DIAGNOSIS SYSTEM (AIRBAG)

## < SYSTEM DESCRIPTION >

Number of 0.5-second blinks	Malfunctioning items	Blinking pattern
5	RH side curtain air bag module	Refer to the following items <ul style="list-style-type: none"> <li>• <a href="#">SRC-119, "DTC Logic"</a></li> <li>• <a href="#">SRC-121, "DTC Logic"</a></li> <li>• <a href="#">SRC-123, "DTC Logic"</a></li> <li>• <a href="#">SRC-125, "DTC Logic"</a></li> </ul>
6	LH side curtain air bag module	Refer to the following items <ul style="list-style-type: none"> <li>• <a href="#">SRC-127, "DTC Logic"</a></li> <li>• <a href="#">SRC-129, "DTC Logic"</a></li> <li>• <a href="#">SRC-131, "DTC Logic"</a></li> <li>• <a href="#">SRC-133, "DTC Logic"</a></li> </ul>

### How to Erase Self Diagnosis Result

After a malfunction is repaired, turn the ignition switch OFF for one second or more, then turn ignition switch ON. The diagnosis mode returns to the user mode. At that time the self-diagnosis result is cleared.

### EXAMPLE OF AIR BAG WARNING LAMP OPERATION IN THE DIAGNOSIS MODE

#### System Normal

When system is normal.

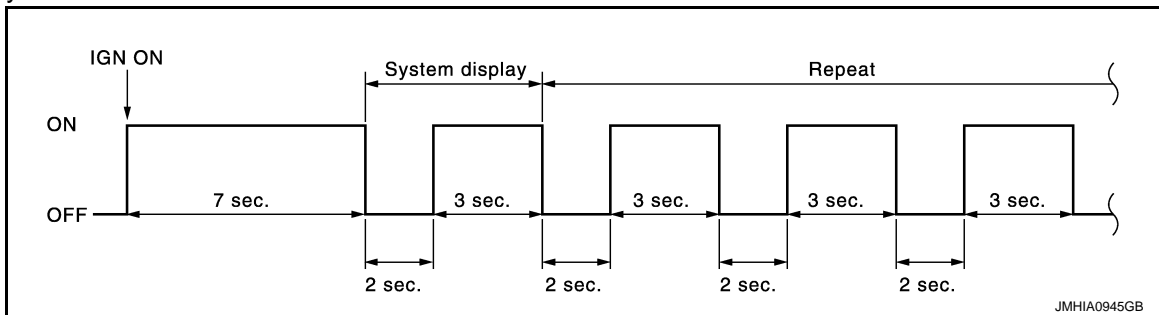

#### Single System Malfunction

- Front air bag system

When air bag diagnosis sensor unit system (Item display 1) is malfunctioning.

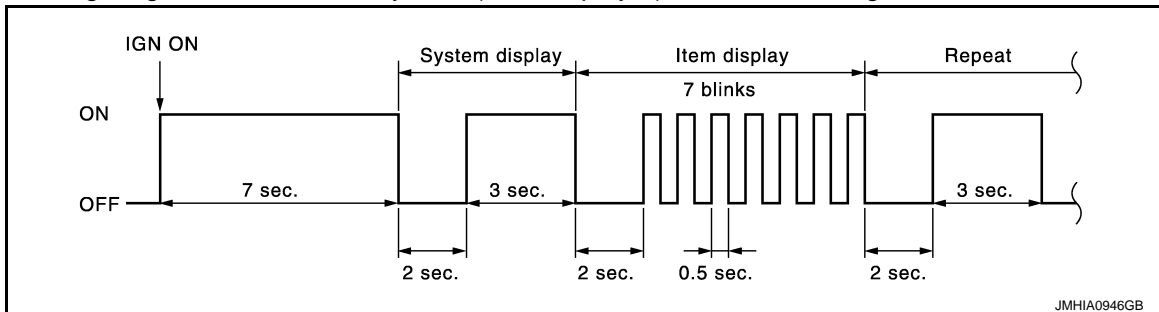

- Side air bag system

When curtain air bag module LH system (Item display 1) is malfunctioning.

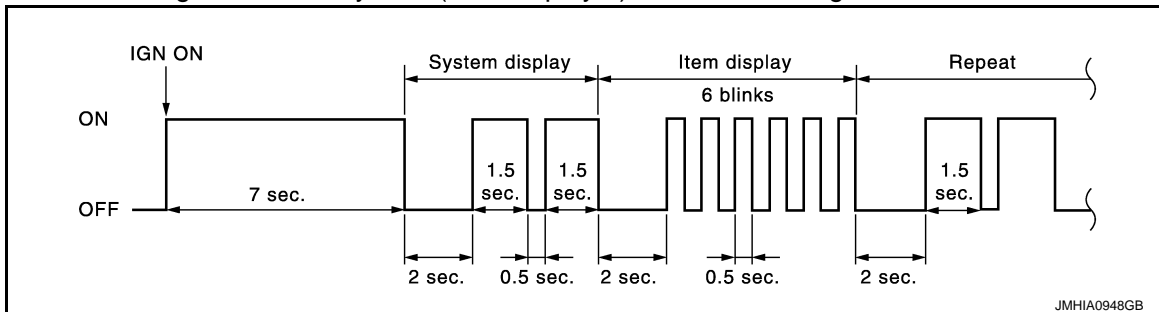

#### Multiple Systems Malfunction

- Front air bag system

# DIAGNOSIS SYSTEM (AIRBAG)

## < SYSTEM DESCRIPTION >

When driver air bag module (Item display 1) and air bag diagnosis sensor unit system (Item display 2) are malfunctioning.

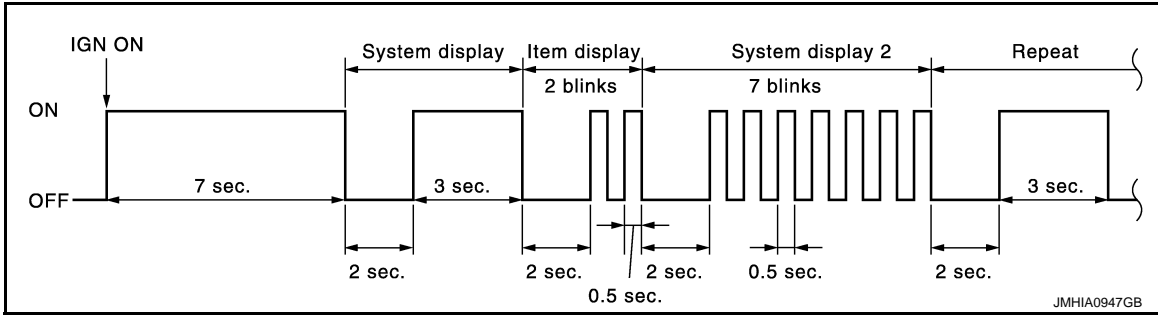

- Side air bag system

When satellite sensor LH (Item display1) and curtain air bag module LH system (Item display 2) are malfunctioning.

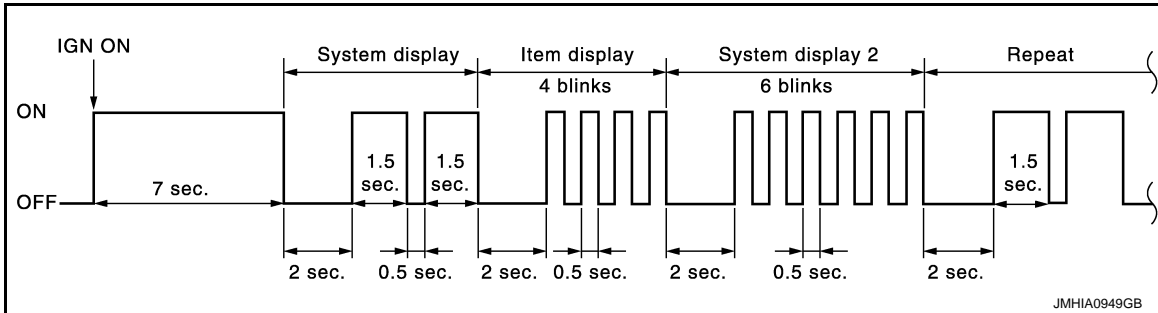

- Front air bag system and side air bag system

When driver air bag module (Item display 1) and satellite sensor RH (Item display2) are malfunctioning.

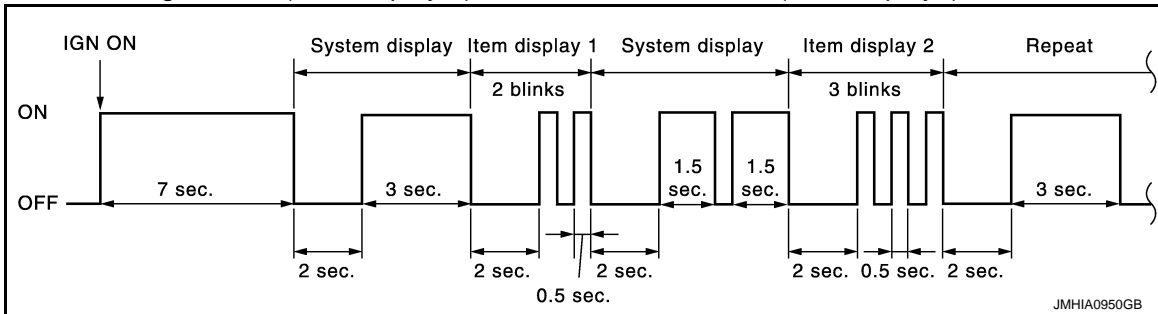

## CONSULT-III Function

INFOID:000000005174167

### APPLICATION ITEM

CONSULT-III performs the following functions.

Diagnosis mode		Description
Ecu Identification		Air bag diagnosis sensor unit ECU discriminated number (identification number) is displayed. Air bag diagnosis sensor unit has individual ECU discriminated number (identification number) based on model and equipment.
Self Diagnostic Result		The current self diagnosis results (also indicated with the number of air bag warning lamp blinks in the diagnosis mode) are displayed on CONSULT-III screen in real time. This refers to a malfunctioning part requiring repairs. Refer to <a href="#">SRC-152, "DTC Index"</a> .
Function Test	CAR COMPUTER DIAG.	Test result is indicated using "OK" or "NG" so that the customer recognizes easily.
Special function	SELF-DIAG [PAST]	Diagnosis results previously stored in the memory are displayed on CONSULT-III screen. The stored results are not erased until memory erasing is executed.
	TROUBLE DIAG RECORD	With TROUBLE DIAG RECORD, diagnosis results previously erased by a reset operation can be displayed on CONSULT-III screen.

## HOW TO ERASE SELF DIAGNOSTIC RESULTS

# DIAGNOSIS SYSTEM (AIRBAG)

## < SYSTEM DESCRIPTION >

---

- “Self Diagnostic Result”  
A current self-diagnosis result is displayed on CONSULT-III screen in real time. A  
After the malfunction is repaired completely, no malfunction is detected on “Self Diagnostic Result”. B
- “SELF-DIAG [PAST]”  
Return to “Self Diagnostic Result” CONSULT-III screen by touching the “BACK” key of CONSULT-III and  
select “Self Diagnostic Result” in SELECT DIAG MODE. Touch “ERASE” in “Self Diagnostic Result” mode. C  
**NOTE:**  
If the memory of the malfunction in “SELF-DIAG [PAST]” is not erased, the user mode shows the system  
malfunction by the illumination of the warning lamp even if the malfunction is repaired completely. D
- “TROUBLE DIAG RECORD”  
The memory of “TROUBLE DIAG RECORD” cannot be erased. E

A

B

C

D

E

F

G

SRC

I

J

K

L

M

N

O

P

# B1001, B1002, B1003, B1004, B1005 DIAGNOSIS SENSOR UNIT

< DTC/CIRCUIT DIAGNOSIS >

## DTC/CIRCUIT DIAGNOSIS

### B1001, B1002, B1003, B1004, B1005 DIAGNOSIS SENSOR UNIT

#### Description

INFOID:000000005174168

- It detects a shock that is more than the specified level and monitors whether the driver and passenger air bags, side air bag, curtain air bag, and pre-tensioner seat belts operate normally.
- It contains the "G" sensors for both frontal and side collisions and spare battery function in case of main battery damage in collision.

#### DTC Logic

INFOID:000000005174169

#### DTC DETECTION LOGIC

DTC	Display contents of CONSULT-III	DTC detecting condition	Possible cause
B1001 B1002 B1003 B1004 B1005	CONTROL UNIT	Air bag diagnosis sensor unit is malfunctioning	Malfunction in air bag diagnosis sensor unit

#### DTC CONFIRMATION PROCEDURE

##### 1. CHECK SELF-DIAG RESULT

With CONSULT-III

1. Turn ignition switch ON.
2. Perform "AIR BAG" Self Diagnostic Result.

Without CONSULT-III

1. Turn ignition switch ON.
2. Check the air bag warning lamp status. Refer to [SRC-15. "Diagnosis with Air Bag Warning Lamp"](#).

#### NOTE:

SRS does not enter the diagnosis mode if no malfunction is detected in the user mode.

Is malfunctioning part detected?

- YES >> Refer to [SRC-22. "Diagnosis Procedure"](#).  
NO >> INSPECTION END

#### Diagnosis Procedure

INFOID:000000005174170

#### WARNING:

- Before servicing, turn ignition switch OFF, disconnect battery negative terminal, and wait 3 minutes or more. (To discharge backup capacitor.)
- Never use unspecified tester or other measuring device.

##### 1. CHECK HARNESS CONNECTOR

Check the harness connector.

Is the inspection result normal?

- YES >> GO TO 2.  
NO >> Replace harness connectors.

##### 2. CHECK WIRING HARNESS

Check the wiring harness externals.

Is the inspection result normal?

- YES >> GO TO 3.  
NO >> Replace wiring harness.

##### 3. REPLACE AIR BAG DIAGNOSIS SENSOR UNIT

1. Replace air bag diagnosis sensor unit. Refer to [SR-25. "Exploded View"](#).

# B1001, B1002, B1003, B1004, B1005 DIAGNOSIS SENSOR UNIT

## < DTC/CIRCUIT DIAGNOSIS >

---

2. Perform DTC confirmation procedure. Refer to [SRC-22. "DTC Logic"](#).

### Is DTC detected?

YES >> GO TO 1.

NO >> INSPECTION END

A

B

C

D

E

F

G

**SRC**

I

J

K

L

M

N

O

P

# B1006, B1007, B1008, B1009, B1010 DIAGNOSIS SENSOR UNIT

< DTC/CIRCUIT DIAGNOSIS >

## B1006, B1007, B1008, B1009, B1010 DIAGNOSIS SENSOR UNIT

### Description

INFOID:000000005174171

- It detects a shock that is more than the specified level and monitors whether the driver and passenger air bags, side air bag, curtain air bag, and pre-tensioner seat belts operate normally.
- It contains the "G" sensors for both frontal and side collisions and spare battery function in case of main battery damage in collision.

### DTC Logic

INFOID:000000005174172

### DTC DETECTION LOGIC

DTC	Display contents of CONSULT-III	DTC detecting condition	Possible cause
B1006 B1007 B1008 B1009 B1010	CONTROL UNIT	Air bag diagnosis sensor unit is malfunctioning	Malfunction in air bag diagnosis sensor unit

### DTC CONFIRMATION PROCEDURE

#### 1. CHECK SELF-DIAG RESULT

With CONSULT-III

1. Turn ignition switch ON.
2. Perform "AIR BAG" Self-Diagnostic Result.

Without CONSULT-III

1. Turn ignition switch ON.
2. Check the air bag warning lamp status. Refer to [SRC-15. "Diagnosis with Air Bag Warning Lamp"](#).

#### NOTE:

SRS does not enter the diagnosis mode if no malfunction is detected in the user mode.

Is malfunctioning part detected?

- YES >> Refer to [SRC-24. "Diagnosis Procedure"](#).  
NO >> INSPECTION END

### Diagnosis Procedure

INFOID:000000005174173

#### WARNING:

- Before servicing, turn ignition switch OFF, disconnect battery negative terminal, and wait 3 minutes or more. (To discharge backup capacitor.)
- Never use unspecified tester or other measuring device.

#### 1. CHECK HARNESS CONNECTOR

Check the harness connector.

Is the inspection result normal?

- YES >> GO TO 2.  
NO >> Replace harness connectors.

#### 2. CHECK WIRING HARNESS

Check the wiring harness externals.

Is the inspection result normal?

- YES >> GO TO 3.  
NO >> Replace wiring harness.

#### 3. REPLACE AIR BAG DIAGNOSIS SENSOR UNIT

1. Replace air bag diagnosis sensor unit. Refer to [SR-25. "Exploded View"](#)
2. Perform DTC confirmation procedure. Refer to [SRC-24. "DTC Logic"](#)

Is DTC detected?



# B1006, B1007, B1008, B1009, B1010 DIAGNOSIS SENSOR UNIT

< DTC/CIRCUIT DIAGNOSIS >

---

YES >> GO TO 1.

NO >> INSPECTION END

A

B

C

D

E

F

G

**SRC**

I

J

K

L

M

N

O

P

# B1011, B1012, B1013, B1014, B1015 DIAGNOSIS SENSOR UNIT

< DTC/CIRCUIT DIAGNOSIS >

## B1011, B1012, B1013, B1014, B1015 DIAGNOSIS SENSOR UNIT

### Description

INFOID:000000005174174

- It detects a shock that is more than the specified level and monitors whether the driver and passenger air bags, side air bag, curtain air bag, and pre-tensioner seat belts operate normally.
- It contains the "G" sensors for both frontal and side collisions and spare battery function in case of main battery damage in collision.

### DTC Logic

INFOID:000000005174175

### DTC DETECTION LOGIC

DTC	Display contents of CONSULT-III	DTC detecting condition	Possible cause
B1011 B1012 B1013 B1014 B1015	CONTROL UNIT	Air bag diagnosis sensor unit is malfunctioning	Malfunction in air bag diagnosis sensor unit

### DTC CONFIRMATION PROCEDURE

#### 1. CHECK SELF-DIAG RESULT

With CONSULT-III

1. Turn ignition switch ON.
2. Perform "AIR BAG" Self Diagnostic Result.

Without CONSULT-III

1. Turn ignition switch ON.
2. Check the air bag warning lamp status. Refer to [SRC-15, "Diagnosis with Air Bag Warning Lamp"](#).

#### NOTE:

SRS does not enter the diagnosis mode if no malfunction is detected in the user mode.

Is malfunctioning part detected?

- YES >> Refer to [SRC-26, "Diagnosis Procedure"](#).  
NO >> INSPECTION END

### Diagnosis Procedure

INFOID:000000005174176

#### WARNING:

- Before servicing, turn ignition switch OFF, disconnect battery negative terminal, and wait 3 minutes or more. (To discharge backup capacitor.)
- Never use unspecified tester or other measuring device.

#### 1. CHECK HARNESS CONNECTOR

Check the harness connector.

Is the inspection result normal?

- YES >> GO TO 2.  
NO >> Replace harness connectors.

#### 2. CHECK WIRING HARNESS

Check the wiring harness externals.

Is the inspection result normal?

- YES >> GO TO 3.  
NO >> Replace wiring harness.

#### 3. REPLACE AIR BAG DIAGNOSIS SENSOR UNIT

1. Replace air bag diagnosis sensor unit. Refer to [SR-25, "Exploded View"](#)
2. Perform DTC confirmation procedure. Refer to [SRC-26, "DTC Logic"](#)

Is DTC detected?

# B1011, B1012, B1013, B1014, B1015 DIAGNOSIS SENSOR UNIT

< DTC/CIRCUIT DIAGNOSIS >

---

YES >> GO TO 1.

NO >> INSPECTION END

A

B

C

D

E

F

G

**SRC**

I

J

K

L

M

N

O

P

# B1017, B1020, B1021 OCCUPANT SYSTEM CONTROL UNIT

< DTC/CIRCUIT DIAGNOSIS >

## B1017, B1020, B1021 OCCUPANT SYSTEM CONTROL UNIT

### Description

INFOID:000000005174177

This unit classifies occupant in passenger seat and detects electrical malfunctions in Occupant Classification System, and transmits malfunction information to air bag diagnosis sensor unit.

### DTC Logic

INFOID:000000005174178

### DTC DETECTION LOGIC

DTC	Display contents of CONSULT-III	DTC detecting condition	Possible cause
B1017 B1020 B1021	OCCUPANT SENS C/U [UNIT FAIL]	Occupant Classification System control unit is malfunctioning	<ul style="list-style-type: none"><li>• Disconnection of wiring harness</li><li>• Malfunction in Occupant Classification System control unit</li><li>• Malfunction in air bag diagnosis sensor unit</li></ul>

### DTC CONFIRMATION PROCEDURE

#### 1. CHECK SELF-DIAG RESULT

With CONSULT-III

1. Turn ignition switch ON.
2. Perform "AIR BAG" Self Diagnostic Result with CONSULT-III.

Without CONSULT-III

1. Turn ignition switch ON.
2. Check the air bag warning lamp status. Refer to [SRC-15, "Diagnosis with Air Bag Warning Lamp"](#).

#### NOTE:

SRS does not enter the diagnosis mode if no malfunction is detected in the user mode.

Is malfunctioning part detected?

- YES >> Refer to [SRC-28, "Diagnosis Procedure"](#).  
NO >> INSPECTION END

### Diagnosis Procedure

INFOID:000000005174179

#### WARNING:

- Before servicing, turn ignition switch OFF, disconnect battery negative terminal, and wait 3 minutes or more. (To discharge backup capacitor.)
- Never use unspecified tester or other measuring device.

### DIAGNOSTIC PROCEDURE

#### 1. CHECK HARNESS CONNECTOR

Check the connection of harness connector.

Is the inspection result normal?

- YES >> GO TO 2.  
NO >> Replace harness connectors.

#### 2. CHECK WIRING HARNESS

Check the wiring harness externals.

Is the inspection result normal?

- YES >> GO TO 3.  
NO >> Replace wiring harness.

#### 3. REPLACE AIR BAG DIAGNOSIS SENSOR UNIT

1. Replace air bag diagnosis sensor unit. Refer to [SR-25, "Exploded View"](#).
2. Perform DTC confirmation procedure. Refer to [SRC-28, "DTC Logic"](#).

Is DTC detected?

- YES >> GO TO 4.

# B1017, B1020, B1021 OCCUPANT SYSTEM CONTROL UNIT

< DTC/CIRCUIT DIAGNOSIS >

---

NO >> INSPECTION END

## 4. REPLACE OCCUPANT CLASSIFICATION SYSTEM CONTROL UNIT

---

1. Replace passenger seat cushion assembly. Refer to [SE-129, "Exploded View"](#).
2. Perform DTC confirmation procedure. Refer to [SRC-28, "DTC Logic"](#).

Is DTC detected?

YES >> GO TO 1.

NO >> INSPECTION END

A  
B  
C  
D  
E  
F  
G  
I  
J  
K  
L  
M  
N  
O  
P

SRC

# B1018 OCCUPANT SYSTEM SENSOR

< DTC/CIRCUIT DIAGNOSIS >

## B1018 OCCUPANT SYSTEM SENSOR

### Description

INFOID:000000005174180

Occupant Classification System sensor detects occupant in passenger seat and transmits it to Occupant Classification System control unit.

### DTC Logic

INFOID:000000005174181

### DTC DETECTION LOGIC

DTC	Display contents of CONSULT-III	DTC detecting condition	Possible cause
B1018	OCCUPANT SENS [UNIT FAIL]	Occupant Classification System sensor is malfunctioning	<ul style="list-style-type: none"><li>• Disconnection of wiring harness</li><li>• Malfunction in Occupant Classification System sensor</li><li>• Malfunction in Occupant Classification System control unit</li><li>• Malfunction in air bag diagnosis sensor unit</li></ul>

### DTC CONFIRMATION PROCEDURE

#### 1. CHECK SELF-DIAG RESULT

Ⓟ With CONSULT-III

1. Turn ignition switch ON.
2. Perform "AIR BAG" Self Diagnostic Result with CONSULT-III.

ⓧ Without CONSULT-III

1. Turn ignition switch ON.
2. Check the air bag warning lamp status. Refer to [SRC-15, "Diagnosis with Air Bag Warning Lamp"](#).

#### NOTE:

SRS does not enter the diagnosis mode if no malfunction is detected in the user mode.

Is malfunctioning part detected?

- YES >> Refer to [SRC-30, "Diagnosis Procedure"](#).  
NO >> INSPECTION END

### Diagnosis Procedure

INFOID:000000005174182

#### WARNING:

- Before servicing, turn ignition switch OFF, disconnect battery negative terminal, and wait 3 minutes or more. (To discharge backup capacitor.)
- Never use unspecified tester or other measuring device.

### DIAGNOSTIC PROCEDURE

#### 1. CHECK HARNESS CONNECTOR

Check the connection of harness connector.

Is the inspection result normal?

- YES >> GO TO 2.  
NO >> Replace harness connectors.

#### 2. CHECK WIRING HARNESS

Check the wiring harness externals.

Is the inspection result normal?

- YES >> GO TO 3.  
NO >> Replace wiring harness.

#### 3. REPLACE AIR BAG DIAGNOSIS SENSOR UNIT

1. Replace air bag diagnosis sensor unit. Refer to [SR-25, "Exploded View"](#).
2. Perform DTC confirmation procedure. Refer to [SRC-30, "DTC Logic"](#).

Is DTC detected?

- YES >> GO TO 4.

## B1018 OCCUPANT SYSTEM SENSOR

< DTC/CIRCUIT DIAGNOSIS >

---

NO >> INSPECTION END

### 4. REPLACE OCCUPANT CLASSIFICATION SYSTEM CONTROL UNIT AND SENSOR

---

1. Replace passenger seat cushion assembly. Refer to [SE-129, "Exploded View"](#).
2. Perform DTC confirmation procedure. Refer to [SRC-30, "DTC Logic"](#).

Is DTC detected?

YES >> GO TO 1.

NO >> INSPECTION END

A

B

C

D

E

F

G

SRC

I

J

K

L

M

N

O

P

# B1022 OCCUPANT SYSTEM CONTROL UNIT

< DTC/CIRCUIT DIAGNOSIS >

## B1022 OCCUPANT SYSTEM CONTROL UNIT

### Description

INFOID:000000005174183

This unit classifies occupant in passenger seat and detects electrical malfunctions in Occupant Classification System, and transmits malfunction information to air bag diagnosis sensor unit.

### DTC Logic

INFOID:000000005174184

### DTC DETECTION LOGIC

DTC	Display contents of CONSULT-III	DTC detecting condition	Possible cause
B1022	OCCUPANT SENS C/U [COMM FAIL]	Malfunction occurs in Occupant Classification System control unit, circuit of Occupant Classification System control unit-Air bag diagnosis sensor unit, or Air bag diagnosis sensor unit	<ul style="list-style-type: none"><li>• Disconnection of wiring harness</li><li>• Malfunction in Occupant Classification System control unit</li><li>• Malfunction in air bag diagnosis sensor unit</li></ul>

### DTC CONFIRMATION PROCEDURE

#### 1. CHECK SELF-DIAG RESULT

With CONSULT-III

1. Turn ignition switch ON.
2. Perform "AIR BAG" Self Diagnostic Result with CONSULT-III.

Without CONSULT-III

1. Turn ignition switch ON.
2. Check the air bag warning lamp status. Refer to [SRC-15. "Diagnosis with Air Bag Warning Lamp"](#).

#### NOTE:

SRS does not enter the diagnosis mode if no malfunction is detected in the user mode.

Is malfunctioning part detected?

YES >> Refer to [SRC-32. "Diagnosis Procedure"](#).

NO >> INSPECTION END

### Diagnosis Procedure

INFOID:000000005174185

#### WARNING:

- Before servicing, turn ignition switch OFF, disconnect battery negative terminal, and wait 3 minutes or more. (To discharge backup capacitor.)
- Never use unspecified tester or other measuring device.

### DIAGNOSTIC PROCEDURE

#### 1. CHECK HARNESS CONNECTOR

Check the connection of harness connector.

Is the inspection result normal?

YES >> GO TO 2.

NO >> Replace harness connectors.

#### 2. CHECK WIRING HARNESS

Check the wiring harness externals.

Is the inspection result normal?

YES >> GO TO 3.

NO >> Replace wiring harness.

#### 3. REPLACE AIR BAG DIAGNOSIS SENSOR UNIT

1. Replace air bag diagnosis sensor unit. Refer to [SR-25. "Exploded View"](#).
2. Perform DTC confirmation procedure. Refer to [SRC-32. "DTC Logic"](#).

Is DTC detected?



## B1022 OCCUPANT SYSTEM CONTROL UNIT

### < DTC/CIRCUIT DIAGNOSIS >

---

YES >> GO TO 4.

NO >> INSPECTION END

### 4. CHECK OCCUPANT CLASSIFICATION SYSTEM CONTROL UNIT

---

1. Replace passenger seat cushion assembly. Refer to [SE-129. "Exploded View"](#).

2. Perform DTC confirmation procedure. Refer to [SRC-32. "DTC Logic"](#).

#### Is DTC detected?

YES >> GO TO 1.

NO >> INSPECTION END

A

B

C

D

E

F

G

SRC

I

J

K

L

M

N

O

P

# B1023 PASSENGER AIR BAG OFF INDICATOR

< DTC/CIRCUIT DIAGNOSIS >

## B1023 PASSENGER AIR BAG OFF INDICATOR

### Description

INFOID:000000005174186

Illuminates passenger air bag OFF indicator when the passenger seat is empty or occupied by a child or a child-seat.

### DTC Logic

INFOID:000000005174187

### DTC DETECTION LOGIC

DTC	Display contents of CONSULT-III	DTC detecting condition	Possible cause
B1023	PASS A/B INDCTR CKT [UNIT FAIL]	Passenger air bag OFF indicator circuit is open or shorted to ground or the circuits are shorted each other	<ul style="list-style-type: none"><li>• Disconnection of wiring harness</li><li>• Malfunction in passenger air bag OFF indicator</li><li>• Malfunction in air bag diagnosis sensor unit</li></ul>

### DTC CONFIRMATION PROCEDURE

#### 1. CHECK SELF-DIAG RESULT

With CONSULT-III

1. Turn ignition switch ON.
2. Perform "AIR BAG" Self Diagnostic Result with CONSULT-III.

Without CONSULT-III

1. Turn ignition switch ON.
2. Check the air bag warning lamp status. Refer to [SRC-15, "Diagnosis with Air Bag Warning Lamp"](#).

#### NOTE:

SRS does not enter the diagnosis mode if no malfunction is detected in the user mode.

Is malfunctioning part detected?

- YES >> Refer to [SRC-34, "Diagnosis Procedure"](#).  
NO >> INSPECTION END

### Diagnosis Procedure

INFOID:000000005174188

#### WARNING:

- Before servicing, turn ignition switch OFF, disconnect battery negative terminal, and wait 3 minutes or more. (To discharge backup capacitor.)
- Never use unspecified tester or other measuring device.

### DIAGNOSTIC PROCEDURE

#### 1. CHECK HARNESS CONNECTOR

Check the connection of harness connector.

Is the inspection result normal?

- YES >> GO TO 2.  
NO >> Replace harness connectors.

#### 2. CHECK WIRING HARNESS

Check the wiring harness externals.

Is the inspection result normal?

- YES >> GO TO 3.  
NO >> Replace wiring harness.

#### 3. REPLACE AIR BAG DIAGNOSIS SENSOR UNIT

1. Replace air bag diagnosis sensor unit. Refer to [SR-25, "Exploded View"](#).
2. Perform DTC confirmation procedure. Refer to [SRC-34, "DTC Logic"](#).

Is DTC detected?

- YES >> GO TO 4.  
NO >> INSPECTION END

# B1023 PASSENGER AIR BAG OFF INDICATOR

< DTC/CIRCUIT DIAGNOSIS >

---

## 4. CHECK PASSENGER AIR BAG OFF INDICATOR

---

1. Replace passenger air bag OFF indicator. Refer to [IP-11, "Exploded View"](#)
2. Perform DTC confirmation procedure. Refer to [SRC-34, "DTC Logic"](#).

Is DTC detected?

YES >> GO TO 1.  
NO >> INSPECTION END

A  
B  
C  
D  
E  
F  
G  
I  
J  
K  
L  
M  
N  
O  
P

SRC

# B1025, B1032, B1048 OCCUPANT SYSTEM SENSOR

< DTC/CIRCUIT DIAGNOSIS >

## B1025, B1032, B1048 OCCUPANT SYSTEM SENSOR

### Description

INFOID:000000005174189

Occupant Classification System sensor detects occupant in passenger seat and transmits it to Occupant Classification System control unit.

### DTC Logic

INFOID:000000005174190

### DTC DETECTION LOGIC

DTC	Display contents of CONSULT-III	DTC detecting condition	Possible cause
B1025 B1032 B1048	OCS SENSOR	Malfunction occurs in Occupant Classification System control unit, circuit of Occupant Classification System control unit-Air bag diagnosis sensor unit, or Air bag diagnosis sensor unit	<ul style="list-style-type: none"><li>• Disconnection of wiring harness</li><li>• Internal breakdown in Occupant Classification System control unit</li><li>• Malfunction in air bag diagnosis sensor unit</li></ul>

### DTC CONFIRMATION PROCEDURE

#### 1. CHECK SELF-DIAG RESULT

With CONSULT-III

1. Turn ignition switch ON.
2. Perform "AIR BAG" Self Diagnostic Result with CONSULT-III.

Without CONSULT-III

1. Turn ignition switch ON.
2. Check the air bag warning lamp status. Refer to [SRC-15. "Diagnosis with Air Bag Warning Lamp"](#).

#### NOTE:

SRS does not enter the diagnosis mode if no malfunction is detected in the user mode.

Is malfunctioning part detected?

- YES >> Refer to [SRC-36. "Diagnosis Procedure"](#).  
NO >> INSPECTION END

### Diagnosis Procedure

INFOID:000000005174191

#### WARNING:

- Before servicing, turn ignition switch OFF, disconnect battery negative terminal, and wait 3 minutes or more. (To discharge backup capacitor.)
- Never use unspecified tester or other measuring device.

### DIAGNOSTIC PROCEDURE

#### 1. CHECK HARNESS CONNECTOR

Check the connection of harness connector.

Is the inspection result normal?

- YES >> GO TO 2.  
NO >> Replace harness connectors.

#### 2. CHECK WIRING HARNESS

Check the wiring harness externals.

Is the inspection result normal?

- YES >> GO TO 3.  
NO >> Replace wiring harness.

#### 3. REPLACE AIR BAG DIAGNOSIS SENSOR UNIT

1. Replace air bag diagnosis sensor unit. Refer to [SR-25. "Exploded View"](#).
2. Perform DTC confirmation procedure. Refer to [SRC-36. "DTC Logic"](#).

Is DTC detected?

## B1025, B1032, B1048 OCCUPANT SYSTEM SENSOR

### < DTC/CIRCUIT DIAGNOSIS >

---

YES >> GO TO 4.

NO >> INSPECTION END

A

### 4. CHECK OCCUPANT DETECTION SYSTEM CONTROL UNIT

---

1. Replace passenger seat cushion assembly. Refer to [SE-129. "Exploded View"](#).

2. Perform DTC confirmation procedure. Refer to [SRC-36. "DTC Logic"](#).

B

#### Is DTC detected?

YES >> GO TO 1.

NO >> INSPECTION END

C

D

E

F

G

SRC

I

J

K

L

M

N

O

P

# B1026, B1027, B1028, B1029, B1030, B1031 DIAGNOSIS SENSOR UNIT

< DTC/CIRCUIT DIAGNOSIS >

## B1026, B1027, B1028, B1029, B1030, B1031 DIAGNOSIS SENSOR UNIT

### Description

INFOID:000000005174192

- It detects a shock that is more than the specified level and monitors whether the driver and passenger air bags, side air bag, curtain air bag, and pre-tensioner seat belts operate normally.
- It contains the "G" sensors for both frontal and side collisions and spare battery function in case of main battery damage in collision.

### DTC Logic

INFOID:000000005174193

### DTC DETECTION LOGIC

DTC	Display contents of CONSULT-III	DTC detecting condition	Possible cause
B1026 B1027 B1028 B1029 B1030 B1031	CONTROL UNIT	Air bag diagnosis sensor unit is malfunctioning	Malfunction in air bag diagnosis sensor unit

### DTC CONFIRMATION PROCEDURE

#### 1. CHECK SELF-DIAG RESULT

With CONSULT-III

1. Turn ignition switch ON.
2. Perform "AIR BAG" Self Diagnostic Result.

Without CONSULT-III

1. Turn ignition switch ON.
2. Check the air bag warning lamp status. Refer to [SRC-15, "Diagnosis with Air Bag Warning Lamp"](#).

#### NOTE:

SRS does not enter the diagnosis mode if no malfunction is detected in the user mode.

Is malfunctioning part detected?

- YES >> Refer to [SRC-38, "Diagnosis Procedure"](#).  
NO >> INSPECTION END

### Diagnosis Procedure

INFOID:000000005174194

#### WARNING:

- Before servicing, turn ignition switch OFF, disconnect battery negative terminal, and wait 3 minutes or more. (To discharge backup capacitor.)
- Never use unspecified tester or other measuring device.

#### 1. CHECK HARNESS CONNECTOR

Check the harness connector.

Is the inspection result normal?

- YES >> GO TO 2.  
NO >> Replace harness connectors.

#### 2. CHECK WIRING HARNESS

Check the wiring harness externals.

Is the inspection result normal?

- YES >> GO TO 3.  
NO >> Replace wiring harness.

#### 3. REPLACE AIR BAG DIAGNOSIS SENSOR UNIT

1. Replace air bag diagnosis sensor unit. Refer to [SR-25, "Exploded View"](#).
2. Perform DTC confirmation procedure. Refer to [SRC-38, "DTC Logic"](#).

# B1026, B1027, B1028, B1029, B1030, B1031 DIAGNOSIS SENSOR UNIT

< DTC/CIRCUIT DIAGNOSIS >

---

Is DTC detected?

YES >> GO TO 1.

NO >> INSPECTION END

A

B

C

D

E

F

G

**SRC**

I

J

K

L

M

N

O

P

# B1033, B1034 CRASH ZONE SENSOR

< DTC/CIRCUIT DIAGNOSIS >

## B1033, B1034 CRASH ZONE SENSOR

### Description

INFOID:000000005174195

Crash zone sensor is a G sensor that outputs voltage signal during deceleration at the time of a vehicle frontal collision that is more than the specified limit is detected.

### DTC Logic

INFOID:000000005174196

### DTC DETECTION LOGIC

DTC	Display contents of CONSULT-III	DTC detecting condition	Possible cause
B1033 B1034	CRASH ZONE SENSOR [UNIT FAIL]	Crash zone sensor is malfunctioning	<ul style="list-style-type: none"><li>• Disconnection of wiring harness</li><li>• Malfunction in crash zone sensor</li><li>• Malfunction in air bag diagnosis sensor unit</li></ul>

### DTC CONFIRMATION PROCEDURE

#### 1. CHECK SELF-DIAG RESULT

With CONSULT-III

1. Turn ignition switch ON.
2. Perform "AIR BAG" Self Diagnostic Result.

Without CONSULT-III

1. Turn ignition switch ON.
2. Check the air bag warning lamp status. Refer to [SRC-15, "Diagnosis with Air Bag Warning Lamp"](#).

#### NOTE:

SRS does not enter the diagnosis mode if no malfunction is detected in the user mode.

Is malfunctioning part detected?

- YES >> Refer to [SRC-40, "Diagnosis Procedure"](#).  
NO >> INSPECTION END

### Diagnosis Procedure

INFOID:000000005174197

#### WARNING:

- Before servicing, turn ignition switch OFF, disconnect battery negative terminal, and wait 3 minutes or more. (To discharge backup capacitor.)
- Never use unspecified tester or other measuring device.

#### 1. CHECK HARNESS CONNECTOR

Check the harness connector.

Is the inspection result normal?

- YES >> GO TO 2.  
NO >> Replace harness connectors.

#### 2. CHECK WIRING HARNESS

Check the wiring harness externals.

Is the inspection result normal?

- YES >> GO TO 3.  
NO >> Replace wiring harness.

#### 3. REPLACE AIR BAG DIAGNOSIS SENSOR UNIT

1. Replace air bag diagnosis sensor unit. Refer to [SR-25, "Exploded View"](#).
2. Perform DTC confirmation procedure. Refer to [SRC-40, "DTC Logic"](#).

Is DTC detected?

- YES >> GO TO 4.  
NO >> INSPECTION END

#### 4. REPLACE CRASH ZONE SENSOR



## B1033, B1034 CRASH ZONE SENSOR

### < DTC/CIRCUIT DIAGNOSIS >

---

1. Replace crash zone sensor. Refer to [SR-21, "Exploded View"](#).
2. Perform DTC confirmation procedure. Refer to [SRC-40, "DTC Logic"](#).

#### Is DTC detected?

YES >> GO TO 1.

NO >> INSPECTION END

A

B

C

D

E

F

G

**SRC**

I

J

K

L

M

N

O

P

# B1035, B1036 CRASH ZONE SENSOR

< DTC/CIRCUIT DIAGNOSIS >

## B1035, B1036 CRASH ZONE SENSOR

### Description

INFOID:000000005174198

Crash zone sensor is a G sensor that outputs voltage signal during deceleration at the time of a vehicle frontal collision that is more than the specified limit is detected.

### DTC Logic

INFOID:000000005174199

### DTC DETECTION LOGIC

DTC	Display contents of CONSULT-III	DTC detecting condition	Possible cause
B1035 B1036	CRASH ZONE SENSOR [COMM FAIL] [UNMATCH]	Crash zone sensor is malfunctioning or out of the specified specification	<ul style="list-style-type: none"><li>• Disconnection of wiring harness</li><li>• Malfunction in crash zone sensor</li><li>• Malfunction in air bag diagnosis sensor unit</li></ul>

### DTC CONFIRMATION PROCEDURE

#### 1. CHECK SELF-DIAG RESULT

With CONSULT-III

1. Turn ignition switch ON.
2. Perform "AIR BAG" Self Diagnostic Result.

Without CONSULT-III

1. Turn ignition switch ON.
2. Check the air bag warning lamp status. Refer to [SRC-15. "Diagnosis with Air Bag Warning Lamp"](#).

#### NOTE:

SRS does not enter the diagnosis mode if no malfunction is detected in the user mode.

Is malfunctioning part detected?

- YES >> Refer to [SRC-42. "Diagnosis Procedure"](#).  
NO >> INSPECTION END

### Diagnosis Procedure

INFOID:000000005174200

#### WARNING:

- Before servicing, turn ignition switch OFF, disconnect battery negative terminal, and wait 3 minutes or more. (To discharge backup capacitor.)
- Never use unspecified tester or other measuring device.

#### 1. CHECK HARNESS CONNECTOR

Check the harness connector.

Is the inspection result normal?

- YES >> GO TO 2.  
NO >> Replace harness connectors.

#### 2. CHECK WIRING HARNESS

Check the wiring harness externals.

Is the inspection result normal?

- YES >> GO TO 3.  
NO >> Replace wiring harness.

#### 3. REPLACE AIR BAG DIAGNOSIS SENSOR UNIT

1. Replace air bag diagnosis sensor unit. Refer to [SR-25. "Exploded View"](#).
2. Perform DTC confirmation procedure. Refer to [SRC-42. "DTC Logic"](#).

Is DTC detected?

- YES >> GO TO 4.  
NO >> INSPECTION END

## B1035, B1036 CRASH ZONE SENSOR

< DTC/CIRCUIT DIAGNOSIS >

---

### 4. REPLACE CRASH ZONE SENSOR

---

1. Replace crash zone sensor. Refer to [SR-21, "Exploded View"](#).
2. Perform DTC confirmation procedure. Refer to [SRC-42, "DTC Logic"](#).

Is DTC detected?

YES >> GO TO 1.  
NO >> INSPECTION END

A  
B  
C  
D  
E  
F  
G  
I  
J  
K  
L  
M  
N  
O  
P

SRC

# B1037, B1039, B1041 CRASH ZONE SENSOR

< DTC/CIRCUIT DIAGNOSIS >

## B1037, B1039, B1041 CRASH ZONE SENSOR

### Description

INFOID:000000005174201

Crash zone sensor is a G sensor that outputs voltage signal during deceleration at the time of a vehicle frontal collision that is more than the specified limit is detected.

### DTC Logic

INFOID:000000005174202

### DTC DETECTION LOGIC

DTC	Display contents of CONSULT-III	DTC detecting condition	Possible cause
B1037 B1039 B1041	CRASH ZONE SENSOR1	Crash zone sensor is malfunctioning	<ul style="list-style-type: none"><li>• Disconnection of wiring harness</li><li>• Malfunction in crash zone sensor</li><li>• Malfunction in air bag diagnosis sensor unit</li></ul>

### DTC CONFIRMATION PROCEDURE

#### 1. CHECK SELF-DIAG RESULT

With CONSULT-III

1. Turn ignition switch ON.
2. Perform "AIR BAG" Self Diagnostic Result.

Without CONSULT-III

1. Turn ignition switch ON.
2. Check the air bag warning lamp status. Refer to [SRC-15, "Diagnosis with Air Bag Warning Lamp"](#).

#### NOTE:

SRS does not enter the diagnosis mode if no malfunction is detected in the user mode.

Is malfunctioning part detected?

- YES >> Refer to [SRC-44, "Diagnosis Procedure"](#).  
NO >> INSPECTION END

### Diagnosis Procedure

INFOID:000000005174203

#### WARNING:

- Before servicing, turn ignition switch OFF, disconnect battery negative terminal, and wait 3 minutes or more. (To discharge backup capacitor.)
- Never use unspecified tester or other measuring device.

#### 1. CHECK HARNESS CONNECTOR

Check the harness connector.

Is the inspection result normal?

- YES >> GO TO 2.  
NO >> Replace harness connectors.

#### 2. CHECK WIRING HARNESS

Check the wiring harness externals.

Is the inspection result normal?

- YES >> GO TO 3.  
NO >> Replace wiring harness.

#### 3. REPLACE AIR BAG DIAGNOSIS SENSOR UNIT

1. Replace air bag diagnosis sensor unit. Refer to [SR-25, "Exploded View"](#).
2. Perform DTC confirmation procedure. Refer to [SRC-44, "DTC Logic"](#).

Is DTC detected?

- YES >> GO TO 4.  
NO >> INSPECTION END

#### 4. REPLACE CRASH ZONE SENSOR

## B1037, B1039, B1041 CRASH ZONE SENSOR

### < DTC/CIRCUIT DIAGNOSIS >

---

1. Replace crash zone sensor. Refer to [SR-21, "Exploded View"](#).
2. Perform DTC confirmation procedure. Refer to [SRC-44, "DTC Logic"](#).

#### Is DTC detected?

YES >> GO TO 1.

NO >> INSPECTION END

A

B

C

D

E

F

G

**SRC**

I

J

K

L

M

N

O

P

# B1042, B1043, B1044, B1045, B1046, B1047 DIAGNOSIS SENSOR UNIT

< DTC/CIRCUIT DIAGNOSIS >

## B1042, B1043, B1044, B1045, B1046, B1047 DIAGNOSIS SENSOR UNIT

### Description

INFOID:000000005174204

- It detects a shock that is more than the specified level and monitors whether the driver and passenger air bags, side air bag, curtain air bag, and pre-tensioner seat belts operate normally.
- It contains the "G" sensors for both frontal and side collisions and spare battery function in case of main battery damage in collision.

### DTC Logic

INFOID:000000005174205

### DTC DETECTION LOGIC

DTC	Display contents of CONSULT-III	DTC detecting condition	Possible cause
B1042 B1043 B1044 B1045 B1046 B1047	CONTROL UNIT	Air bag diagnosis sensor unit is malfunctioning	Malfunction in air bag diagnosis sensor unit

### DTC CONFIRMATION PROCEDURE

#### 1. CHECK SELF-DIAG RESULT

With CONSULT-III

1. Turn ignition switch ON.
2. Perform "AIR BAG" Self Diagnostic Result.

Without CONSULT-III

1. Turn ignition switch ON.
2. Check the air bag warning lamp status. Refer to [SRC-15, "Diagnosis with Air Bag Warning Lamp"](#).

#### NOTE:

SRS does not enter the diagnosis mode if no malfunction is detected in the user mode.

Is malfunctioning part detected?

- YES >> Refer to [SRC-46, "Diagnosis Procedure"](#).  
NO >> INSPECTION END

### Diagnosis Procedure

INFOID:000000005174206

#### WARNING:

- Before servicing, turn ignition switch OFF, disconnect battery negative terminal, and wait 3 minutes or more. (To discharge backup capacitor.)
- Never use unspecified tester or other measuring device.

#### 1. CHECK HARNESS CONNECTOR

Check the harness connector.

Is the inspection result normal?

- YES >> GO TO 2.  
NO >> Replace harness connectors.

#### 2. CHECK WIRING HARNESS

Check the wiring harness externals.

Is the inspection result normal?

- YES >> GO TO 3.  
NO >> Replace wiring harness.

#### 3. REPLACE AIR BAG DIAGNOSIS SENSOR UNIT

1. Replace air bag diagnosis sensor unit. Refer to [SR-25, "Exploded View"](#).
2. Perform DTC confirmation procedure. Refer to [SRC-46, "DTC Logic"](#).

# B1042, B1043, B1044, B1045, B1046, B1047 DIAGNOSIS SENSOR UNIT

< DTC/CIRCUIT DIAGNOSIS >

---

Is DTC detected?

YES >> GO TO 1.

NO >> INSPECTION END

A

B

C

D

E

F

G

**SRC**

I

J

K

L

M

N

O

P

# B1049, B1054 DRIVER AIR BAG MODULE

< DTC/CIRCUIT DIAGNOSIS >

## B1049, B1054 DRIVER AIR BAG MODULE

### Description

INFOID:000000005174207

In case of frontal collision where acceleration is more than the specified level, the ignition materials are ignited by electric ignition system. The system burns the gas generating materials resulting in a chemical reaction. This generates hot gases that flow into the air bag through a filter and expand the bag.

### DTC Logic

INFOID:000000005174208

### DTC DETECTION LOGIC

DTC	Display contents of CONSULT-III	DTC detecting condition	Possible cause
B1049 B1054	DRIVER AIRBAG MODULE [OPEN]	Driver air bag module circuit is open (including the spiral cable)	<ul style="list-style-type: none"><li>• Disconnection of wiring harness and open</li><li>• Malfunction in driver air bag module</li><li>• Malfunction in spiral cable</li><li>• Malfunction in air bag diagnosis sensor unit</li></ul>

### DTC CONFIRMATION PROCEDURE

#### 1. CHECK SELF-DIAG RESULT

With CONSULT-III

1. Turn ignition switch ON.
2. Perform "AIR BAG" Self Diagnostic Result.

Without CONSULT-III

1. Turn ignition switch ON.
2. Check the air bag warning lamp status. Refer to [SRC-15, "Diagnosis with Air Bag Warning Lamp"](#).

#### NOTE:

SRS does not enter the diagnosis mode if no malfunction is detected in the user mode.

Is malfunctioning part detected?

- YES >> Refer to [SRC-48, "Diagnosis Procedure"](#).  
NO >> INSPECTION END

### Diagnosis Procedure

INFOID:000000005174209

#### WARNING:

- Before servicing, turn ignition switch OFF, disconnect battery negative terminal, and wait 3 minutes or more. (To discharge backup capacitor.)
- Never use unspecified tester or other measuring device.

#### 1. CHECK HARNESS CONNECTOR

Check the harness connector.

Is the inspection result normal?

- YES >> GO TO 2.  
NO >> Replace harness connector.

#### 2. CHECK WIRING HARNESS

Check the wiring harness externals.

Is the inspection result normal?

- YES >> GO TO 3.  
NO >> Replace wiring harness.

#### 3. CHECK SPIRAL CABLE CIRCUIT

1. Turn ignition switch OFF.
2. Disconnect driver air bag module connector and combination switch (spiral cable) connector.
3. Check continuity between driver air bag module harness connector and combination switch (spiral cable) harness connector.



# B1049, B1054 DRIVER AIR BAG MODULE

## < DTC/CIRCUIT DIAGNOSIS >

Driver air bag module		Combination switch (spiral cable)		Continuity
Connector	Terminal	Connector	Terminal	
M302	10	M35	28	Existed
	11		30	
M301	12		29	
	9		30	

4. Check continuity between driver air bag module harness connector and ground.

Driver side air bag module		Ground	Continuity
Connector	Terminal		
M302	10	Ground	Not existed
	11		
M301	12		
	9		

Is the inspection result normal?

YES >> GO TO 4.

NO >> Replace combination switch (spiral cable). Refer to [SR-14, "Exploded View"](#).

### 4. REPLACE AIR BAG DIAGNOSIS SENSOR UNIT

1. Replace air bag diagnosis sensor unit. Refer to [SR-25, "Exploded View"](#)
2. Perform DTC confirmation procedure. Refer to [SRC-48, "DTC Logic"](#).

Is DTC detected?

YES >> GO TO 5.

NO >> INSPECTION END

### 5. REPLACE DRIVER AIR BAG MODULE

1. Replace driver air bag module. Refer to [SR-11, "Exploded View"](#)
2. Perform DTC confirmation procedure. Refer to [SRC-48, "DTC Logic"](#).

Is DTC detected?

YES >> GO TO 1.

NO >> INSPECTION END

A  
B  
C  
D  
E  
F  
G  
I  
J  
K  
L  
M  
N  
O  
P

SRC

# B1050, B1055 DRIVER AIR BAG MODULE

< DTC/CIRCUIT DIAGNOSIS >

## B1050, B1055 DRIVER AIR BAG MODULE

### Description

INFOID:0000000051742.10

In case of frontal collision where acceleration is more than the specified level, the ignition materials are ignited by electric ignition system. The system burns the gas generating materials resulting in a chemical reaction. This generates hot gases that flow into the air bag through a filter and expand the bag.

### DTC Logic

INFOID:0000000051742.11

### DTC DETECTION LOGIC

DTC	Display contents of CONSULT-III	DTC detecting condition	Possible cause
B1050 B1055	DRIVER AIRBAG MODULE [VB-SHORT]	Driver air bag module circuit is shorted to power supply circuit (including the spiral cable)	<ul style="list-style-type: none"><li>• Disconnection of wiring harness and short</li><li>• Malfunction in driver air bag module</li><li>• Malfunction in spiral cable</li><li>• Malfunction in air bag diagnosis sensor unit</li></ul>

### DTC CONFIRMATION PROCEDURE

#### 1. CHECK SELF-DIAG RESULT

With CONSULT-III

1. Turn ignition switch ON.
2. Perform "AIR BAG" Self Diagnostic Result.

Without CONSULT-III

1. Turn ignition switch ON.
2. Check the air bag warning lamp status. Refer to [SRC-15. "Diagnosis with Air Bag Warning Lamp"](#).

#### NOTE:

SRS does not enter the diagnosis mode if no malfunction is detected in the user mode.

Is malfunctioning part detected?

- YES >> Refer to [SRC-50. "Diagnosis Procedure"](#).  
NO >> INSPECTION END

### Diagnosis Procedure

INFOID:0000000051742.12

#### WARNING:

- Before servicing, turn ignition switch OFF, disconnect battery negative terminal, and wait 3 minutes or more. (To discharge backup capacitor.)
- Never use unspecified tester or other measuring device.

#### 1. CHECK HARNESS CONNECTOR

Check the harness connector.

Is the inspection result normal?

- YES >> GO TO 2.  
NO >> Replace harness connector.

#### 2. CHECK WIRING HARNESS

Check the wiring harness externals.

Is the inspection result normal?

- YES >> GO TO 3.  
NO >> Replace wiring harness.

#### 3. CHECK SPIRAL CABLE CIRCUIT

1. Turn ignition switch OFF.
2. Disconnect driver air bag module connector and combination switch (spiral cable) connector.
3. Check continuity between driver air bag module harness connector and combination switch (spiral cable) harness connector.

# B1050, B1055 DRIVER AIR BAG MODULE

## < DTC/CIRCUIT DIAGNOSIS >

Driver air bag module		Combination switch (spiral cable)		Continuity
Connector	Terminal	Connector	Terminal	
M302	10	M35	28	Existed
	11		30	
M301	12		29	
	9		30	

4. Check continuity between driver air bag module harness connector and ground.

Driver side air bag module		Ground	Continuity
Connector	Terminal		
M302	10	Ground	Not existed
	11		
M301	12		
	9		

Is the inspection result normal?

YES >> GO TO 4.

NO >> Replace combination switch (spiral cable). Refer to [SR-14, "Exploded View"](#).

### 4. REPLACE AIR BAG DIAGNOSIS SENSOR UNIT

1. Replace air bag diagnosis sensor unit. Refer to [SR-25, "Exploded View"](#)
2. Perform DTC confirmation procedure. Refer to [SRC-50, "DTC Logic"](#).

Is DTC detected?

YES >> GO TO 5.

NO >> INSPECTION END

### 5. REPLACE DRIVER AIR BAG MODULE

1. Replace driver air bag module. Refer to [SR-11, "Exploded View"](#)
2. Perform DTC confirmation procedure. Refer to [SRC-50, "DTC Logic"](#).

Is DTC detected?

YES >> GO TO 1.

NO >> INSPECTION END

# B1051, B1056 DRIVER AIR BAG MODULE

< DTC/CIRCUIT DIAGNOSIS >

## B1051, B1056 DRIVER AIR BAG MODULE

### Description

INFOID:000000005174213

In case of frontal collision where acceleration is more than the specified level, the ignition materials are ignited by electric ignition system. The system burns the gas generating materials resulting in a chemical reaction. This generates hot gases that flow into the air bag through a filter and expand the bag.

### DTC Logic

INFOID:000000005174214

### DTC DETECTION LOGIC

DTC	Display contents of CONSULT-III	DTC detecting condition	Possible cause
B1051 B1056	DRIVER AIRBAG MODULE [GND-SHORT]	Driver air bag module circuit is shorted to ground (including the spiral cable)	<ul style="list-style-type: none"><li>• Disconnection of wiring harness and short</li><li>• Malfunction in driver air bag module</li><li>• Malfunction in spiral cable</li><li>• Malfunction in air bag diagnosis sensor unit</li></ul>

### DTC CONFIRMATION PROCEDURE

#### 1. CHECK SELF-DIAG RESULT

With CONSULT-III

1. Turn ignition switch ON.
2. Perform "AIR BAG" Self Diagnostic Result.

Without CONSULT-III

1. Turn ignition switch ON.
2. Check the air bag warning lamp status. Refer to [SRC-15, "Diagnosis with Air Bag Warning Lamp"](#).

#### NOTE:

SRS does not enter the diagnosis mode if no malfunction is detected in the user mode.

Is malfunctioning part detected?

- YES >> Refer to [SRC-52, "Diagnosis Procedure"](#).  
NO >> INSPECTION END

### Diagnosis Procedure

INFOID:000000005174215

#### WARNING:

- Before servicing, turn ignition switch OFF, disconnect battery negative terminal, and wait 3 minutes or more. (To discharge backup capacitor.)
- Never use unspecified tester or other measuring device.

#### 1. CHECK HARNESS CONNECTOR

Check the harness connector.

Is the inspection result normal?

- YES >> GO TO 2.  
NO >> Replace harness connector.

#### 2. CHECK WIRING HARNESS

Check the wiring harness externals.

Is the inspection result normal?

- YES >> GO TO 3.  
NO >> Replace wiring harness.

#### 3. CHECK SPIRAL CABLE CIRCUIT

1. Turn ignition switch OFF.
2. Disconnect driver air bag module connector and combination switch (spiral cable) connector.
3. Check continuity between driver air bag module harness connector and combination switch (spiral cable) harness connector.

# B1051, B1056 DRIVER AIR BAG MODULE

## < DTC/CIRCUIT DIAGNOSIS >

Driver air bag module		Combination switch (spiral cable)		Continuity
Connector	Terminal	Connector	Terminal	
M302	10	M35	28	Existed
	11		30	
M301	12		29	
	9		30	

4. Check continuity between driver air bag module harness connector and ground.

Driver side air bag module		Ground	Continuity
Connector	Terminal		
M302	10	Ground	Not existed
	11		
M301	12		
	9		

Is the inspection result normal?

YES >> GO TO 4.

NO >> Replace combination switch (spiral cable). Refer to [SR-14, "Exploded View"](#).

### 4. REPLACE AIR BAG DIAGNOSIS SENSOR UNIT

1. Replace air bag diagnosis sensor unit. Refer to [SR-25, "Exploded View"](#)
2. Perform DTC confirmation procedure. Refer to [SRC-52, "DTC Logic"](#).

Is DTC detected?

YES >> GO TO 5.

NO >> INSPECTION END

### 5. REPLACE DRIVER AIR BAG MODULE

1. Replace driver air bag module. Refer to [SR-11, "Exploded View"](#)
2. Perform DTC confirmation procedure. Refer to [SRC-52, "DTC Logic"](#).

Is DTC detected?

YES >> GO TO 1.

NO >> INSPECTION END

A  
B  
C  
D  
E  
F  
G  
I  
J  
K  
L  
M  
N  
O  
P

SRC

# B1052, B1057 DRIVER AIR BAG MODULE

< DTC/CIRCUIT DIAGNOSIS >

## B1052, B1057 DRIVER AIR BAG MODULE

### Description

INFOID:000000005174216

In case of frontal collision where acceleration is more than the specified level, the ignition materials are ignited by electric ignition system. The system burns the gas generating materials resulting in a chemical reaction. This generates hot gases that flow into the air bag through a filter and expand the bag.

### DTC Logic

INFOID:000000005174217

### DTC DETECTION LOGIC

DTC	Display contents of CONSULT-III	DTC detecting condition	Possible cause
B1052 B1057	DRIVER AIRBAG MODULE [SHORT]	Driver air bag module circuit are shorted to each other (including the spiral cable)	<ul style="list-style-type: none"><li>• Disconnection of wiring harness and short</li><li>• Malfunction in driver air bag module</li><li>• Malfunction in spiral cable</li><li>• Malfunction in air bag diagnosis sensor unit</li></ul>

### DTC CONFIRMATION PROCEDURE

#### 1. CHECK SELF-DIAG RESULT

Ⓟ With CONSULT-III

1. Turn ignition switch ON.
2. Perform "AIR BAG" Self Diagnostic Result.

ⓧ Without CONSULT-III

1. Turn ignition switch ON.
2. Check the air bag warning lamp status. Refer to [SRC-15. "Diagnosis with Air Bag Warning Lamp"](#).

#### NOTE:

SRS does not enter the diagnosis mode if no malfunction is detected in the user mode.

Is malfunctioning part detected?

- YES >> Refer to [SRC-54. "Diagnosis Procedure"](#).  
NO >> INSPECTION END

### Diagnosis Procedure

INFOID:000000005174218

#### WARNING:

- Before servicing, turn ignition switch OFF, disconnect battery negative terminal, and wait 3 minutes or more. (To discharge backup capacitor.)
- Never use unspecified tester or other measuring device.

#### 1. CHECK HARNESS CONNECTOR

Check the harness connector.

Is the inspection result normal?

- YES >> GO TO 2.  
NO >> Replace harness connector.

#### 2. CHECK WIRING HARNESS

Check the wiring harness externals.

Is the inspection result normal?

- YES >> GO TO 3.  
NO >> Replace wiring harness.

#### 3. CHECK SPIRAL CABLE CIRCUIT

1. Turn ignition switch OFF.
2. Disconnect driver air bag module connector and combination switch (spiral cable) connector.
3. Check continuity between driver air bag module harness connector and combination switch (spiral cable) harness connector.

# B1052, B1057 DRIVER AIR BAG MODULE

## < DTC/CIRCUIT DIAGNOSIS >

Driver air bag module		Combination switch (spiral cable)		Continuity
Connector	Terminal	Connector	Terminal	
M302	10	M35	28	Existed
	11		30	
M301	12		29	
	9		30	

4. Check continuity between driver air bag module harness connector and ground.

Driver side air bag module		Ground	Continuity
Connector	Terminal		
M302	10	Ground	Not existed
	11		
M301	12		
	9		

Is the inspection result normal?

YES >> GO TO 4.

NO >> Replace combination switch (spiral cable). Refer to [SR-14, "Exploded View"](#).

### 4. REPLACE AIR BAG DIAGNOSIS SENSOR UNIT

1. Replace air bag diagnosis sensor unit. Refer to [SR-25, "Exploded View"](#)
2. Perform DTC confirmation procedure. Refer to [SRC-54, "DTC Logic"](#).

Is DTC detected?

YES >> GO TO 5.

NO >> INSPECTION END

### 5. REPLACE DRIVER AIR BAG MODULE

1. Replace driver air bag module. Refer to [SR-11, "Exploded View"](#)
2. Perform DTC confirmation procedure. Refer to [SRC-54, "DTC Logic"](#).

Is DTC detected?

YES >> GO TO 1.

NO >> INSPECTION END

# B1058, B1059, B1060, B1061, B1062, B1063 DIAGNOSIS SENSOR UNIT

< DTC/CIRCUIT DIAGNOSIS >

## B1058, B1059, B1060, B1061, B1062, B1063 DIAGNOSIS SENSOR UNIT

### Description

INFOID:000000005174219

- It detects a shock that is more than the specified level and monitors whether the driver and passenger air bags, side air bag, curtain air bag, and pre-tensioner seat belts operate normally.
- It contains the "G" sensors for both frontal and side collisions and spare battery function in case of main battery damage in collision.

### DTC Logic

INFOID:000000005174220

### DTC DETECTION LOGIC

DTC	Display contents of CONSULT-III	DTC detecting condition	Possible cause
B1058 B1059 B1060 B1061 B1062 B1063	CONTROL UNIT	Air bag diagnosis sensor unit is malfunctioning	Malfunction in air bag diagnosis sensor unit

### DTC CONFIRMATION PROCEDURE

#### 1. CHECK SELF-DIAG RESULT

With CONSULT-III

1. Turn ignition switch ON.
2. Perform "AIR BAG" Self Diagnostic Result.

Without CONSULT-III

1. Turn ignition switch ON.
2. Check the air bag warning lamp status. Refer to [SRC-15, "Diagnosis with Air Bag Warning Lamp"](#).

#### NOTE:

SRS does not enter the diagnosis mode if no malfunction is detected in the user mode.

Is malfunctioning part detected?

- YES >> Refer to [SRC-56, "Diagnosis Procedure"](#).  
NO >> INSPECTION END

### Diagnosis Procedure

INFOID:000000005174221

#### WARNING:

- Before servicing, turn ignition switch OFF, disconnect battery negative terminal, and wait 3 minutes or more. (To discharge backup capacitor.)
- Never use unspecified tester or other measuring device.

#### 1. CHECK HARNESS CONNECTOR

Check the harness connector.

Is the inspection result normal?

- YES >> GO TO 2.  
NO >> Replace harness connectors.

#### 2. CHECK WIRING HARNESS

Check the wiring harness externals.

Is the inspection result normal?

- YES >> GO TO 3.  
NO >> Replace wiring harness.

#### 3. REPLACE AIR BAG DIAGNOSIS SENSOR UNIT

1. Replace air bag diagnosis sensor unit. Refer to [SR-25, "Exploded View"](#).
2. Perform DTC confirmation procedure. Refer to [SRC-56, "DTC Logic"](#).



# B1058, B1059, B1060, B1061, B1062, B1063 DIAGNOSIS SENSOR UNIT

< DTC/CIRCUIT DIAGNOSIS >

---

Is DTC detected?

YES >> GO TO 1.

NO >> INSPECTION END

A

B

C

D

E

F

G

**SRC**

I

J

K

L

M

N

O

P

# B1065, B1070 PASSENGER AIR BAG MODULE

< DTC/CIRCUIT DIAGNOSIS >

## B1065, B1070 PASSENGER AIR BAG MODULE

### Description

INFOID:000000005174222

In case of frontal collision where acceleration is more than the specified level, the ignition materials are ignited by electric ignition system. The system burns the gas generating materials resulting in a chemical reaction. This generates hot gases that flow into the air bag through a filter and expand the bag.

### DTC Logic

INFOID:000000005174223

### DTC DETECTION LOGIC

DTC	Display contents of CONSULT-III	DTC detecting condition	Possible cause
B1065 B1070	ASSIST A/B MODULE [OPEN]	Passenger air bag module circuit is open	<ul style="list-style-type: none"><li>• Disconnection of wiring harness and open</li><li>• Malfunction in passenger air bag module</li><li>• Malfunction in air bag diagnosis sensor unit</li></ul>

### DTC CONFIRMATION PROCEDURE

#### 1. CHECK SELF-DIAG RESULT

With CONSULT-III

1. Turn ignition switch ON.
2. Perform "AIR BAG" Self Diagnostic Result.

Without CONSULT-III

1. Turn ignition switch ON.
2. Check the air bag warning lamp status. Refer to [SRC-15. "Diagnosis with Air Bag Warning Lamp"](#).

#### NOTE:

SRS does not enter the diagnosis mode if no malfunction is detected in the user mode.

Is malfunctioning part detected?

- YES >> Refer to [SRC-58. "Diagnosis Procedure"](#).  
NO >> INSPECTION END

### Diagnosis Procedure

INFOID:000000005174224

#### WARNING:

- Before servicing, turn ignition switch OFF, disconnect battery negative terminal, and wait at least 3 minutes or more. (To discharge backup capacitor.)
- Never use unspecified tester or other measuring device.

#### 1. CHECK HARNESS CONNECTOR

Check the harness connector.

Is the inspection result normal?

- YES >> GO TO 2.  
NO >> Replace harness connector.

#### 2. CHECK WIRING HARNESS

Check the wiring harness externals.

Is the inspection result normal?

- YES >> GO TO 3.  
NO >> Replace wiring harness.

#### 3. REPLACE AIR BAG DIAGNOSIS SENSOR UNIT

1. Replace air bag diagnosis sensor unit. Refer to [SR-25. "Exploded View"](#).
2. Perform DTC confirmation procedure. Refer to [SRC-58. "DTC Logic"](#).

Is DTC detected?

- YES >> GO TO 4.  
NO >> INSPECTION END

# B1065, B1070 PASSENGER AIR BAG MODULE

< DTC/CIRCUIT DIAGNOSIS >

---

## 4. REPLACE FRONT PASSENGER AIR BAG MODULE

---

1. Replace front passenger air bag module. Refer to [SR-17, "Exploded View"](#)
2. Perform DTC confirmation procedure. Refer to [SRC-58, "DTC Logic"](#).

Is DTC detected?

YES >> GO TO 1.  
NO >> INSPECTION END

A  
B  
C  
D  
E  
F  
G  
I  
J  
K  
L  
M  
N  
O  
P

SRC

# B1066, B1071 PASSENGER AIR BAG MODULE

< DTC/CIRCUIT DIAGNOSIS >

## B1066, B1071 PASSENGER AIR BAG MODULE

### Description

INFOID:000000005174225

In case of frontal collision where acceleration is more than the specified level, the ignition materials are ignited by electric ignition system. The system burns the gas generating materials resulting in a chemical reaction. This generates hot gases that flow into the air bag through a filter and expand the bag.

### DTC Logic

INFOID:000000005174226

### DTC DETECTION LOGIC

DTC	Display contents of CONSULT-III	DTC detecting condition	Possible cause
B1066 B1071	ASSIST A/B MODULE [VB-SHORT]	Passenger air bag module circuit is shorted to power supply circuit	<ul style="list-style-type: none"><li>• Disconnection of wiring harness and short</li><li>• Malfunction in passenger air bag module</li><li>• Malfunction in air bag diagnosis sensor unit</li></ul>

### DTC CONFIRMATION PROCEDURE

#### 1. CHECK SELF-DIAG RESULT

With CONSULT-III

1. Turn ignition switch ON.
2. Perform "AIR BAG" Self Diagnostic Result.

Without CONSULT-III

1. Turn ignition switch ON.
2. Check the air bag warning lamp status. Refer to [SRC-15. "Diagnosis with Air Bag Warning Lamp"](#).

#### NOTE:

SRS does not enter the diagnosis mode if no malfunction is detected in the user mode.

Is malfunctioning part detected?

- YES >> Refer to [SRC-60. "Diagnosis Procedure"](#).  
NO >> INSPECTION END

### Diagnosis Procedure

INFOID:000000005174227

#### WARNING:

- Before servicing, turn ignition switch OFF, disconnect battery negative terminal, and wait at least 3 minutes or more. (To discharge backup capacitor.)
- Never use unspecified tester or other measuring device.

#### 1. CHECK HARNESS CONNECTOR

Check the harness connector.

Is the inspection result normal?

- YES >> GO TO 2.  
NO >> Replace harness connector.

#### 2. CHECK WIRING HARNESS

Check the wiring harness externals.

Is the inspection result normal?

- YES >> GO TO 3.  
NO >> Replace wiring harness.

#### 3. REPLACE AIR BAG DIAGNOSIS SENSOR UNIT

1. Replace air bag diagnosis sensor unit. Refer to [SR-25. "Exploded View"](#).
2. Perform DTC confirmation procedure. Refer to [SRC-60. "DTC Logic"](#).

Is DTC detected?

- YES >> GO TO 4.  
NO >> INSPECTION END

# B1066, B1071 PASSENGER AIR BAG MODULE

< DTC/CIRCUIT DIAGNOSIS >

---

## 4. REPLACE FRONT PASSENGER AIR BAG MODULE

---

1. Replace front passenger air bag module. Refer to [SR-17, "Exploded View"](#).
2. Perform DTC confirmation procedure. Refer to [SRC-60, "DTC Logic"](#).

Is DTC detected?

YES >> GO TO 1.  
NO >> INSPECTION END

A  
B  
C  
D  
E  
F  
G  
I  
J  
K  
L  
M  
N  
O  
P

SRC

# B1067, B1072 PASSENGER AIR BAG MODULE

< DTC/CIRCUIT DIAGNOSIS >

## B1067, B1072 PASSENGER AIR BAG MODULE

### Description

INFOID:000000005174228

In case of frontal collision where acceleration is more than the specified level, the ignition materials are ignited by electric ignition system. The system burns the gas generating materials resulting in a chemical reaction. This generates hot gases that flow into the air bag through a filter and expand the bag.

### DTC Logic

INFOID:000000005174229

### DTC DETECTION LOGIC

DTC	Display contents of CONSULT-III	DTC detecting condition	Possible cause
B1067 B1072	ASSIST A/B MODULE [GND-SHORT]	Passenger air bag module circuit is shorted to ground	<ul style="list-style-type: none"><li>• Disconnection of wiring harness and short</li><li>• Malfunction in passenger air bag module</li><li>• Malfunction in air bag diagnosis sensor unit</li></ul>

### DTC CONFIRMATION PROCEDURE

#### 1. CHECK SELF-DIAG RESULT

With CONSULT-III

1. Turn ignition switch ON.
2. Perform "AIR BAG" Self Diagnostic Result.

Without CONSULT-III

1. Turn ignition switch ON.
2. Check the air bag warning lamp status. Refer to [SRC-15. "Diagnosis with Air Bag Warning Lamp"](#).

#### NOTE:

SRS does not enter the diagnosis mode if no malfunction is detected in the user mode.

Is malfunctioning part detected?

- YES >> Refer to [SRC-62. "Diagnosis Procedure"](#).  
NO >> INSPECTION END

### Diagnosis Procedure

INFOID:000000005174230

#### WARNING:

- Before servicing, turn ignition switch OFF, disconnect battery negative terminal, and wait at least 3 minutes or more. (To discharge backup capacitor.)
- Never use unspecified tester or other measuring device.

#### 1. CHECK HARNESS CONNECTOR

Check the harness connector.

Is the inspection result normal?

- YES >> GO TO 2.  
NO >> Replace harness connector.

#### 2. CHECK WIRING HARNESS

Check the wiring harness externals.

Is the inspection result normal?

- YES >> GO TO 3.  
NO >> Replace wiring harness.

#### 3. REPLACE AIR BAG DIAGNOSIS SENSOR UNIT

1. Replace air bag diagnosis sensor unit. Refer to [SR-25. "Exploded View"](#).
2. Perform DTC confirmation procedure. Refer to [SRC-62. "DTC Logic"](#).

Is DTC detected?

- YES >> GO TO 4.  
NO >> INSPECTION END

# B1067, B1072 PASSENGER AIR BAG MODULE

< DTC/CIRCUIT DIAGNOSIS >

---

## 4. REPLACE FRONT PASSENGER AIR BAG MODULE

---

1. Replace front passenger air bag module. Refer to [SR-17, "Exploded View"](#)
2. Perform DTC confirmation procedure. Refer to [SRC-62, "DTC Logic"](#).

Is DTC detected?

YES >> GO TO 1.  
NO >> INSPECTION END

A  
B  
C  
D  
E  
F  
G  
I  
J  
K  
L  
M  
N  
O  
P

**SRC**

# B1068, B1073 PASSENGER AIR BAG MODULE

< DTC/CIRCUIT DIAGNOSIS >

## B1068, B1073 PASSENGER AIR BAG MODULE

### Description

INFOID:000000005174231

In case of frontal collision where acceleration is more than the specified level, the ignition materials are ignited by electric ignition system. The system burns the gas generating materials resulting in a chemical reaction. This generates hot gases that flow into the air bag through a filter and expand the bag.

### DTC Logic

INFOID:000000005174232

### DTC DETECTION LOGIC

DTC	Display contents of CONSULT-III	DTC detecting condition	Possible cause
B1068 B1073	ASSIST A/B MODULE [SHORT]	Passenger air bag module circuits are shorted to each other	<ul style="list-style-type: none"><li>• Disconnection of wiring harness and short</li><li>• Malfunction in passenger air bag module</li><li>• Malfunction in air bag diagnosis sensor unit</li></ul>

### DTC CONFIRMATION PROCEDURE

#### 1. CHECK SELF-DIAG RESULT

With CONSULT-III

1. Turn ignition switch ON.
2. Perform "AIR BAG" Self Diagnostic Result.

Without CONSULT-III

1. Turn ignition switch ON.
2. Check the air bag warning lamp status. Refer to [SRC-15. "Diagnosis with Air Bag Warning Lamp"](#).

#### NOTE:

SRS does not enter the diagnosis mode if no malfunction is detected in the user mode.

Is malfunctioning part detected?

- YES >> Refer to [SRC-64. "Diagnosis Procedure"](#).  
NO >> INSPECTION END

### Diagnosis Procedure

INFOID:000000005174233

#### WARNING:

- Before servicing, turn ignition switch OFF, disconnect battery negative terminal, and wait at least 3 minutes or more. (To discharge backup capacitor.)
- Never use unspecified tester or other measuring device.

#### 1. CHECK HARNESS CONNECTOR

Check the harness connector.

Is the inspection result normal?

- YES >> GO TO 2.  
NO >> Replace harness connector.

#### 2. CHECK WIRING HARNESS

Check the wiring harness externals.

Is the inspection result normal?

- YES >> GO TO 3.  
NO >> Replace wiring harness.

#### 3. REPLACE AIR BAG DIAGNOSIS SENSOR UNIT

1. Replace air bag diagnosis sensor unit. Refer to [SR-25. "Exploded View"](#).
2. Perform DTC confirmation procedure. Refer to [SRC-64. "DTC Logic"](#).

Is DTC detected?

- YES >> GO TO 4.  
NO >> INSPECTION END



# B1068, B1073 PASSENGER AIR BAG MODULE

< DTC/CIRCUIT DIAGNOSIS >

---

## 4. REPLACE FRONT PASSENGER AIR BAG MODULE

---

1. Replace front passenger air bag module. Refer to [SR-17, "Exploded View"](#)
2. Perform DTC confirmation procedure. Refer to [SRC-64, "DTC Logic"](#).

Is DTC detected?

YES >> GO TO 1.  
NO >> INSPECTION END

A  
B  
C  
D  
E  
F  
G  
I  
J  
K  
L  
M  
N  
O  
P

**SRC**

# B1074, B1075, B1076, B1077, B1078, B1079 DIAGNOSIS SENSOR UNIT

< DTC/CIRCUIT DIAGNOSIS >

## B1074, B1075, B1076, B1077, B1078, B1079 DIAGNOSIS SENSOR UNIT

### Description

INFOID:000000005174234

- It detects a shock that is more than the specified level and monitors whether the driver and passenger air bags, side air bag, curtain air bag, and pre-tensioner seat belts operate normally.
- It contains the "G" sensors for both frontal and side collisions and spare battery function in case of main battery damage in collision.

### DTC Logic

INFOID:000000005174235

### DTC DETECTION LOGIC

DTC	Display contents of CONSULT-III	DTC detecting condition	Possible cause
B1074 B1075 B1076 B1077 B1078 B1079	CONTROL UNIT	Air bag diagnosis sensor unit is malfunctioning	Malfunction in air bag diagnosis sensor unit

### DTC CONFIRMATION PROCEDURE

#### 1. CHECK SELF-DIAG RESULT

Ⓟ With CONSULT-III

1. Turn ignition switch ON.
2. Perform "AIR BAG" Self Diagnostic Result.

Ⓟ Without CONSULT-III

1. Turn ignition switch ON.
2. Check the air bag warning lamp status. Refer to [SRC-15, "Diagnosis with Air Bag Warning Lamp"](#).

#### NOTE:

SRS does not enter the diagnosis mode if no malfunction is detected in the user mode.

Is malfunctioning part detected?

- YES >> Refer to [SRC-66, "Diagnosis Procedure"](#).  
NO >> INSPECTION END

### Diagnosis Procedure

INFOID:000000005174236

#### WARNING:

- Before servicing, turn ignition switch OFF, disconnect battery negative terminal, and wait at least 3 minutes or more. (To discharge backup capacitor.)
- Never use unspecified tester or other measuring device.

#### 1. CHECK HARNESS CONNECTOR

Check the harness connector.

Is the inspection result normal?

- YES >> GO TO 2.  
NO >> Replace harness connectors.

#### 2. CHECK WIRING HARNESS

Check the wiring harness externals.

Is the inspection result normal?

- YES >> GO TO 3.  
NO >> Replace wiring harness.

#### 3. REPLACE AIR BAG DIAGNOSIS SENSOR UNIT

1. Replace air bag diagnosis sensor unit. Refer to [SR-25, "Exploded View"](#).
2. Perform DTC confirmation procedure. Refer to [SRC-66, "DTC Logic"](#).

# B1074, B1075, B1076, B1077, B1078, B1079 DIAGNOSIS SENSOR UNIT

< DTC/CIRCUIT DIAGNOSIS >

---

Is DTC detected?

YES >> GO TO 1.

NO >> INSPECTION END

A

B

C

D

E

F

G

**SRC**

I

J

K

L

M

N

O

P

# B1080, B1096 DRIVER AIR BAG MODULE

< DTC/CIRCUIT DIAGNOSIS >

## B1080, B1096 DRIVER AIR BAG MODULE

### Description

INFOID:000000005174237

In case of frontal collision where acceleration is more than the specified level, the ignition materials are ignited by electric ignition system. The system burns the gas generating materials resulting in a chemical reaction. This generates hot gases that flow into the air bag through a filter and expand the bag.

### DTC Logic

INFOID:000000005174238

### DTC DETECTION LOGIC

DTC	Display contents of CONSULT-III	DTC detecting condition	Possible cause
B1080 B1096	DRIVER AIRBAG MODULE [SHORT]	Driver air bag module circuit are shorted to each other (including the spiral cable)	<ul style="list-style-type: none"><li>• Disconnection of wiring harness and short</li><li>• Malfunction in driver air bag module</li><li>• Malfunction in spiral cable</li><li>• Malfunction in air bag diagnosis sensor unit</li></ul>

### DTC CONFIRMATION PROCEDURE

#### 1. CHECK SELF-DIAG RESULT

With CONSULT-III

1. Turn ignition switch ON.
2. Perform "AIR BAG" Self Diagnostic Result.

Without CONSULT-III

1. Turn ignition switch ON.
2. Check the air bag warning lamp status. Refer to [SRC-15. "Diagnosis with Air Bag Warning Lamp"](#).

#### NOTE:

SRS does not enter the diagnosis mode if no malfunction is detected in the user mode.

Is malfunctioning part detected?

- YES >> Refer to [SRC-68. "Diagnosis Procedure"](#).  
NO >> INSPECTION END

### Diagnosis Procedure

INFOID:000000005174239

#### WARNING:

- Before servicing, turn ignition switch OFF, disconnect battery negative terminal, and wait at least 3 minutes or more. (To discharge backup capacitor.)
- Never use unspecified tester or other measuring device.

#### 1. CHECK HARNESS CONNECTOR

Check the harness connector.

Is the inspection result normal?

- YES >> GO TO 2.  
NO >> Replace harness connector.

#### 2. CHECK WIRING HARNESS

Check the wiring harness externals.

Is the inspection result normal?

- YES >> GO TO 3.  
NO >> Replace wiring harness.

#### 3. CHECK SPIRAL CABLE CIRCUIT

1. Turn ignition switch OFF.
2. Disconnect driver air bag module connector and combination switch (spiral cable) connector.
3. Check continuity between driver air bag module harness connector and combination switch (spiral cable) harness connector.

# B1080, B1096 DRIVER AIR BAG MODULE

## < DTC/CIRCUIT DIAGNOSIS >

Driver air bag module		Combination switch (spiral cable)		Continuity
Connector	Terminal	Connector	Terminal	
M302	10	M35	28	Existed
	11		30	
M301	12		29	
	9		30	

4. Check continuity between driver air bag module harness connector and ground.

Driver side air bag module		Ground	Continuity
Connector	Terminal		
M302	10	Ground	Not existed
	11		
M301	12		
	9		

Is the inspection result normal?

YES >> GO TO 4.

NO >> Replace combination switch (spiral cable). Refer to [SR-14, "Exploded View"](#).

### 4. REPLACE AIR BAG DIAGNOSIS SENSOR UNIT

1. Replace air bag diagnosis sensor unit. Refer to [SR-25, "Exploded View"](#)
2. Perform DTC confirmation procedure. Refer to [SRC-68, "DTC Logic"](#).

Is DTC detected?

YES >> GO TO 5.

NO >> INSPECTION END

### 5. REPLACE DRIVER AIR BAG MODULE

1. Replace driver air bag module. Refer to [SR-11, "Exploded View"](#)
2. Perform DTC confirmation procedure. Refer to [SRC-68, "DTC Logic"](#).

Is DTC detected?

YES >> GO TO 1.

NO >> INSPECTION END

A  
B  
C  
D  
E  
F  
G  
I  
J  
K  
L  
M  
N  
O  
P

SRC

# B1081 SEAT BELT PRE-TENSIONER RH

< DTC/CIRCUIT DIAGNOSIS >

## B1081 SEAT BELT PRE-TENSIONER RH

### Description

INFOID:000000005174240

In the case of a frontal collision that is more than the specified impact level, the air bag diagnosis sensor unit detects the deceleration caused by collision. It restrains the passenger with seat belt easing the stress on passengers chest with load limiter.

### DTC Logic

INFOID:000000005174241

### DTC DETECTION LOGIC

DTC	Display contents of CONSULT-III	DTC detecting condition	Possible cause
B1081	PRE-TEN FRONT RH [OPEN]	Seat belt pre-tensioner RH circuit is open	<ul style="list-style-type: none"><li>• Disconnection of wiring harness and open</li><li>• Malfunction in seat belt pre-tensioner RH</li><li>• Malfunction in air bag diagnosis sensor unit</li></ul>

### DTC CONFIRMATION PROCEDURE

#### 1. CHECK SELF-DIAG RESULT

With CONSULT-III

1. Turn ignition switch ON.
2. Perform "AIR BAG" Self Diagnostic Result.

Without CONSULT-III

1. Turn ignition switch ON.
2. Check the air bag warning lamp status. Refer to [SRC-15. "Diagnosis with Air Bag Warning Lamp"](#).

#### NOTE:

SRS does not enter the diagnosis mode if no malfunction is detected in the user mode.

Is malfunctioning part detected?

- YES >> Refer to [SRC-70. "Diagnosis Procedure"](#).  
NO >> INSPECTION END

### Diagnosis Procedure

INFOID:000000005174242

#### WARNING:

- Before servicing, turn ignition switch OFF, disconnect battery negative terminal, and wait at least 3 minutes or more. (To discharge backup capacitor.)
- Never use unspecified tester or other measuring device.

#### 1. CHECK HARNESS CONNECTOR

Check the harness connector.

Is the inspection result normal?

- YES >> GO TO 2.  
NO >> Replace harness connector.

#### 2. CHECK WIRING HARNESS

Check the wiring harness externals.

Is the inspection result normal?

- YES >> GO TO 3.  
NO >> Replace wiring harness.

#### 3. REPLACE AIR BAG DIAGNOSIS SENSOR UNIT

1. Replace air bag diagnosis sensor unit. Refer to [SR-25. "Exploded View"](#).
2. Perform DTC confirmation procedure. Refer to [SRC-70. "DTC Logic"](#).

Is DTC detected?

- YES >> GO TO 4.  
NO >> INSPECTION END

## B1081 SEAT BELT PRE-TENSIONER RH

< DTC/CIRCUIT DIAGNOSIS >

---

### 4.REPLACE SEAT BELT PRE-TENSIONER

---

1. Replace seat belt pre-tensioner RH. Refer to 7.
2. Perform DTC confirmation procedure. Refer to [SRC-70, "DTC Logic"](#).

Is DTC detected?

YES >> GO TO 1.  
NO >> INSPECTION END

A  
B  
C  
D  
E  
F  
G  
I  
J  
K  
L  
M  
N  
O  
P

SRC

# B1082 SEAT BELT PRE-TENSIONER RH

< DTC/CIRCUIT DIAGNOSIS >

## B1082 SEAT BELT PRE-TENSIONER RH

### Description

INFOID:000000005174243

In the case of a frontal collision that is more than the specified impact level, the air bag diagnosis sensor unit detects the deceleration caused by collision. It restrains the passenger with seat belt easing the stress on passengers chest with load limiter.

### DTC Logic

INFOID:000000005174244

### DTC DETECTION LOGIC

DTC	Display contents of CONSULT-III	DTC detecting condition	Possible cause
B1082	PRE-TEN FRONT RH [VB-SHORT]	Seat belt pre-tensioner RH circuit is shorted to power supply circuit	<ul style="list-style-type: none"><li>• Disconnection of wiring harness and short</li><li>• Malfunction in seat belt pre-tensioner RH</li><li>• Malfunction in air bag diagnosis sensor unit</li></ul>

### DTC CONFIRMATION PROCEDURE

#### 1. CHECK SELF-DIAG RESULT

With CONSULT-III

1. Turn ignition switch ON.
2. Perform "AIR BAG" Self Diagnostic Result.

Without CONSULT-III

1. Turn ignition switch ON.
2. Check the air bag warning lamp status. Refer to [SRC-15. "Diagnosis with Air Bag Warning Lamp"](#).

#### NOTE:

SRS does not enter the diagnosis mode if no malfunction is detected in the user mode.

Is malfunctioning part detected?

- YES >> Refer to [SRC-72. "Diagnosis Procedure"](#).  
NO >> INSPECTION END

### Diagnosis Procedure

INFOID:000000005174245

#### WARNING:

- Before servicing, turn ignition switch OFF, disconnect battery negative terminal, and wait at least 3 minutes or more. (To discharge backup capacitor.)
- Never use unspecified tester or other measuring device.

#### 1. CHECK HARNESS CONNECTOR

Check the harness connector.

Is the inspection result normal?

- YES >> GO TO 2.  
NO >> Replace harness connector.

#### 2. CHECK WIRING HARNESS

Check the wiring harness externals.

Is the inspection result normal?

- YES >> GO TO 3.  
NO >> Replace wiring harness.

#### 3. REPLACE AIR BAG DIAGNOSIS SENSOR UNIT

1. Replace air bag diagnosis sensor unit. Refer to [SR-25. "Exploded View"](#).
2. Perform DTC confirmation procedure. Refer to [SRC-72. "DTC Logic"](#).

Is DTC detected?

- YES >> GO TO 4.  
NO >> INSPECTION END



## B1082 SEAT BELT PRE-TENSIONER RH

< DTC/CIRCUIT DIAGNOSIS >

---

### 4.REPLACE SEAT BELT PRE-TENSIONER

---

1. Replace seat belt pre-tensioner RH. Refer to [SB-6, "SEAT BELT RETRACTOR : Exploded View"](#).
2. Perform DTC confirmation procedure. Refer to [SRC-72, "DTC Logic"](#).

Is DTC detected?

YES >> GO TO 1.  
NO >> INSPECTION END

A  
B  
C  
D  
E  
F  
G  
I  
J  
K  
L  
M  
N  
O  
P

SRC

# B1083 SEAT BELT PRE-TENSIONER RH

< DTC/CIRCUIT DIAGNOSIS >

## B1083 SEAT BELT PRE-TENSIONER RH

### Description

INFOID:000000005174246

In the case of a frontal collision that is more than the specified impact level, the air bag diagnosis sensor unit detects the deceleration caused by collision. It restrains the passenger with seat belt easing the stress on passengers chest with load limiter.

### DTC Logic

INFOID:000000005174247

### DTC DETECTION LOGIC

DTC	Display contents of CONSULT-III	DTC detecting condition	Possible cause
B1083	PRE-TEN FRONT RH [GND-SHORT]	Seat belt pre-tensioner RH circuit is shorted to ground	<ul style="list-style-type: none"><li>• Disconnection of wiring harness and short</li><li>• Malfunction in seat belt pre-tensioner RH</li><li>• Malfunction in air bag diagnosis sensor unit</li></ul>

### DTC CONFIRMATION PROCEDURE

#### 1. CHECK SELF-DIAG RESULT

With CONSULT-III

1. Turn ignition switch ON.
2. Perform "AIR BAG" Self Diagnostic Result.

Without CONSULT-III

1. Turn ignition switch ON.
2. Check the air bag warning lamp status. Refer to [SRC-15. "Diagnosis with Air Bag Warning Lamp"](#).

#### NOTE:

SRS does not enter the diagnosis mode if no malfunction is detected in the user mode.

Is malfunctioning part detected?

- YES >> Refer to [SRC-74. "Diagnosis Procedure"](#).  
NO >> INSPECTION END

### Diagnosis Procedure

INFOID:000000005174248

#### WARNING:

- Before servicing, turn ignition switch OFF, disconnect battery negative terminal, and wait at least 3 minutes or more. (To discharge backup capacitor.)
- Never use unspecified tester or other measuring device.

#### 1. CHECK HARNESS CONNECTOR

Check the harness connector.

Is the inspection result normal?

- YES >> GO TO 2.  
NO >> Replace harness connector.

#### 2. CHECK WIRING HARNESS

Check the wiring harness externals.

Is the inspection result normal?

- YES >> GO TO 3.  
NO >> Replace wiring harness.

#### 3. REPLACE AIR BAG DIAGNOSIS SENSOR UNIT

1. Replace air bag diagnosis sensor unit. Refer to [SR-25. "Exploded View"](#).
2. Perform DTC confirmation procedure. Refer to [SRC-74. "DTC Logic"](#).

Is DTC detected?

- YES >> GO TO 4.  
NO >> INSPECTION END

## B1083 SEAT BELT PRE-TENSIONER RH

< DTC/CIRCUIT DIAGNOSIS >

---

### 4.REPLACE SEAT BELT PRE-TENSIONER

---

1. Replace seat belt pre-tensioner RH. Refer to [SB-6, "SEAT BELT RETRACTOR : Exploded View"](#).
2. Perform DTC confirmation procedure. Refer to [SRC-74, "DTC Logic"](#).

Is DTC detected?

YES >> GO TO 1.  
NO >> INSPECTION END

A  
B  
C  
D  
E  
F  
G  
I  
J  
K  
L  
M  
N  
O  
P

SRC

# B1084 SEAT BELT PRE-TENSIONER RH

< DTC/CIRCUIT DIAGNOSIS >

## B1084 SEAT BELT PRE-TENSIONER RH

### Description

INFOID:000000005174249

In the case of a frontal collision that is more than the specified impact level, the air bag diagnosis sensor unit detects the deceleration caused by collision. It restrains the passenger with seat belt easing the stress on passengers chest with load limiter.

### DTC Logic

INFOID:000000005174250

### DTC DETECTION LOGIC

DTC	Display contents of CONSULT-III	DTC detecting condition	Possible cause
B1084	PRE-TEN FRONT RH [SHORT]	Seat belt pre-tensioner RH circuits are shorted to each other	<ul style="list-style-type: none"><li>• Disconnection of wiring harness and short</li><li>• Malfunction in seat belt pre-tensioner RH</li><li>• Malfunction in air bag diagnosis sensor unit</li></ul>

### DTC CONFIRMATION PROCEDURE

#### 1. CHECK SELF-DIAG RESULT

With CONSULT-III

1. Turn ignition switch ON.
2. Perform "AIR BAG" Self Diagnostic Result.

Without CONSULT-III

1. Turn ignition switch ON.
2. Check the air bag warning lamp status. Refer to [SRC-15. "Diagnosis with Air Bag Warning Lamp"](#).

#### NOTE:

SRS does not enter the diagnosis mode if no malfunction is detected in the user mode.

Is malfunctioning part detected?

- YES >> Refer to [SRC-76. "Diagnosis Procedure"](#).  
NO >> INSPECTION END

### Diagnosis Procedure

INFOID:000000005174251

#### WARNING:

- Before servicing, turn ignition switch OFF, disconnect battery negative terminal, and wait at least 3 minutes or more. (To discharge backup capacitor.)
- Never use unspecified tester or other measuring device.

#### 1. CHECK HARNESS CONNECTOR

Check the harness connector.

Is the inspection result normal?

- YES >> GO TO 2.  
NO >> Replace harness connector.

#### 2. CHECK WIRING HARNESS

Check the wiring harness externals.

Is the inspection result normal?

- YES >> GO TO 3.  
NO >> Replace wiring harness.

#### 3. REPLACE AIR BAG DIAGNOSIS SENSOR UNIT

1. Replace air bag diagnosis sensor unit. Refer to [SR-25. "Exploded View"](#).
2. Perform DTC confirmation procedure. Refer to [SRC-76. "DTC Logic"](#).

Is DTC detected?

- YES >> GO TO 4.  
NO >> INSPECTION END

## B1084 SEAT BELT PRE-TENSIONER RH

< DTC/CIRCUIT DIAGNOSIS >

---

### 4.REPLACE SEAT BELT PRE-TENSIONER

---

1. Replace seat belt pre-tensioner RH. Refer to [SB-6, "SEAT BELT RETRACTOR : Exploded View"](#).
2. Perform DTC confirmation procedure. Refer to [SRC-76, "DTC Logic"](#).

Is DTC detected?

YES >> GO TO 1.  
NO >> INSPECTION END

A  
B  
C  
D  
E  
F  
G  
I  
J  
K  
L  
M  
N  
O  
P

SRC

# B1086 SEAT BELT PRE-TENSIONER LH

< DTC/CIRCUIT DIAGNOSIS >

## B1086 SEAT BELT PRE-TENSIONER LH

### Description

INFOID:000000005174252

In the case of a frontal collision that is more than the specified impact level, the air bag diagnosis sensor unit detects the deceleration caused by collision. It restrains the passenger with seat belt easing the stress on passengers chest with load limiter.

### DTC Logic

INFOID:000000005174253

### DTC DETECTION LOGIC

DTC	Display contents of CONSULT-III	DTC detecting condition	Possible cause
B1086	PRE-TEN FRONT LH [OPEN]	Seat belt pre-tensioner LH circuit is open	<ul style="list-style-type: none"><li>• Disconnection of wiring harness and open</li><li>• Malfunction in seat belt pre-tensioner LH</li><li>• Malfunction in air bag diagnosis sensor unit</li></ul>

### DTC CONFIRMATION PROCEDURE

#### 1. CHECK SELF-DIAG RESULT

With CONSULT-III

1. Turn ignition switch ON.
2. Perform "AIR BAG" Self Diagnostic Result.

Without CONSULT-III

1. Turn ignition switch ON.
2. Check the air bag warning lamp status. Refer to [SRC-15. "Diagnosis with Air Bag Warning Lamp"](#).

#### NOTE:

SRS does not enter the diagnosis mode if no malfunction is detected in the user mode.

Is malfunctioning part detected?

- YES >> Refer to [SRC-78. "Diagnosis Procedure"](#).  
NO >> INSPECTION END

### Diagnosis Procedure

INFOID:000000005174254

#### WARNING:

- Before servicing, turn ignition switch OFF, disconnect battery negative terminal, and wait at least 3 minutes or more. (To discharge backup capacitor.)
- Never use unspecified tester or other measuring device.

#### 1. CHECK HARNESS CONNECTOR

Check the harness connector.

Is the inspection result normal?

- YES >> GO TO 2.  
NO >> Replace harness connector.

#### 2. CHECK WIRING HARNESS

Check the wiring harness externals.

Is the inspection result normal?

- YES >> GO TO 3.  
NO >> Replace wiring harness.

#### 3. REPLACE AIR BAG DIAGNOSIS SENSOR UNIT

1. Replace air bag diagnosis sensor unit. Refer to [SR-25. "Exploded View"](#).
2. Perform DTC confirmation procedure. Refer to [SRC-78. "DTC Logic"](#).

Is DTC detected?

- YES >> GO TO 4.  
NO >> INSPECTION END

## B1086 SEAT BELT PRE-TENSIONER LH

< DTC/CIRCUIT DIAGNOSIS >

---

### 4. REPLACE SEAT BELT PRE-TENSIONER

---

1. Replace seat belt pre-tensioner LH. Refer to [SB-6. "SEAT BELT RETRACTOR : Exploded View"](#).
2. Perform DTC confirmation procedure. Refer to [SRC-78. "DTC Logic"](#).

Is DTC detected?

YES >> GO TO 1.  
NO >> INSPECTION END

A  
B  
C  
D  
E  
F  
G  
I  
J  
K  
L  
M  
N  
O  
P

SRC

# B1087 SEAT BELT PRE-TENSIONER LH

< DTC/CIRCUIT DIAGNOSIS >

## B1087 SEAT BELT PRE-TENSIONER LH

### Description

INFOID:000000005174255

In the case of a frontal collision that is more than the specified impact level, the air bag diagnosis sensor unit detects the deceleration caused by collision. It restrains the passenger with seat belt easing the stress on passengers chest with load limiter.

### DTC Logic

INFOID:000000005174256

### DTC DETECTION LOGIC

DTC	Display contents of CONSULT-III	DTC detecting condition	Possible cause
B1087	PRE-TEN FRONT LH [VB-SHORT]	Seat belt pre-tensioner LH circuit is shorted to power supply circuit	<ul style="list-style-type: none"><li>• Disconnection of wiring harness and short</li><li>• Malfunction in seat belt pre-tensioner LH</li><li>• Malfunction in air bag diagnosis sensor unit</li></ul>

### DTC CONFIRMATION PROCEDURE

#### 1. CHECK SELF-DIAG RESULT

With CONSULT-III

1. Turn ignition switch ON.
2. Perform "AIR BAG" Self Diagnostic Result.

Without CONSULT-III

1. Turn ignition switch ON.
2. Check the air bag warning lamp status. Refer to [SRC-15. "Diagnosis with Air Bag Warning Lamp"](#).

#### NOTE:

SRS does not enter the diagnosis mode if no malfunction is detected in the user mode.

Is malfunctioning part detected?

- YES >> Refer to [SRC-80. "Diagnosis Procedure"](#).  
NO >> INSPECTION END

### Diagnosis Procedure

INFOID:000000005174257

#### WARNING:

- Before servicing, turn ignition switch OFF, disconnect battery negative terminal, and wait at least 3 minutes or more. (To discharge backup capacitor.)
- Never use unspecified tester or other measuring device.

#### 1. CHECK HARNESS CONNECTOR

Check the harness connector.

Is the inspection result normal?

- YES >> GO TO 2.  
NO >> Replace harness connector.

#### 2. CHECK WIRING HARNESS

Check the wiring harness externals.

Is the inspection result normal?

- YES >> GO TO 3.  
NO >> Replace wiring harness.

#### 3. REPLACE AIR BAG DIAGNOSIS SENSOR UNIT

1. Replace air bag diagnosis sensor unit. Refer to [SR-25. "Exploded View"](#).
2. Perform DTC confirmation procedure. Refer to [SRC-80. "DTC Logic"](#).

Is DTC detected?

- YES >> GO TO 4.  
NO >> INSPECTION END



## B1087 SEAT BELT PRE-TENSIONER LH

< DTC/CIRCUIT DIAGNOSIS >

---

### 4.REPLACE SEAT BELT PRE-TENSIONER

---

1. Replace seat belt pre-tensioner LH. Refer to [SB-6. "SEAT BELT RETRACTOR : Exploded View"](#).
2. Perform DTC confirmation procedure. Refer to [SRC-80. "DTC Logic"](#).

Is DTC detected?

YES >> GO TO 1.  
NO >> INSPECTION END

A  
B  
C  
D  
E  
F  
G  
I  
J  
K  
L  
M  
N  
O  
P

SRC

# B1088 SEAT BELT PRE-TENSIONER LH

< DTC/CIRCUIT DIAGNOSIS >

## B1088 SEAT BELT PRE-TENSIONER LH

### Description

INFOID:000000005174258

In the case of a frontal collision that is more than the specified impact level, the air bag diagnosis sensor unit detects the deceleration caused by collision. It restrains the passenger with seat belt easing the stress on passengers chest with load limiter.

### DTC Logic

INFOID:000000005174259

### DTC DETECTION LOGIC

DTC	Display contents of CONSULT-III	DTC detecting condition	Possible cause
B1088	PRE-TEN FRONT LH [GND-SHORT]	Seat belt pre-tensioner LH circuit is shorted to ground	<ul style="list-style-type: none"><li>• Disconnection of wiring harness and short</li><li>• Malfunction in seat belt pre-tensioner LH</li><li>• Malfunction in air bag diagnosis sensor unit</li></ul>

### DTC CONFIRMATION PROCEDURE

#### 1. CHECK SELF-DIAG RESULT

With CONSULT-III

1. Turn ignition switch ON.
2. Perform "AIR BAG" Self Diagnostic Result.

Without CONSULT-III

1. Turn ignition switch ON.
2. Check the air bag warning lamp status. Refer to [SRC-15. "Diagnosis with Air Bag Warning Lamp"](#).

#### NOTE:

SRS does not enter the diagnosis mode if no malfunction is detected in the user mode.

Is malfunctioning part detected?

- YES >> Refer to [SRC-82. "Diagnosis Procedure"](#).  
NO >> INSPECTION END

### Diagnosis Procedure

INFOID:000000005174260

#### WARNING:

- Before servicing, turn ignition switch OFF, disconnect battery negative terminal, and wait at least 3 minutes or more. (To discharge backup capacitor.)
- Never use unspecified tester or other measuring device.

#### 1. CHECK HARNESS CONNECTOR

Check the harness connector.

Is the inspection result normal?

- YES >> GO TO 2.  
NO >> Replace harness connector.

#### 2. CHECK WIRING HARNESS

Check the wiring harness externals.

Is the inspection result normal?

- YES >> GO TO 3.  
NO >> Replace wiring harness.

#### 3. REPLACE AIR BAG DIAGNOSIS SENSOR UNIT

1. Replace air bag diagnosis sensor unit. Refer to [SR-25. "Exploded View"](#).
2. Perform DTC confirmation procedure. Refer to [SRC-82. "DTC Logic"](#).

Is DTC detected?

- YES >> GO TO 4.  
NO >> INSPECTION END

## B1088 SEAT BELT PRE-TENSIONER LH

< DTC/CIRCUIT DIAGNOSIS >

---

### 4.REPLACE SEAT BELT PRE-TENSIONER

---

1. Replace seat belt pre-tensioner LH. Refer to [SB-6. "SEAT BELT RETRACTOR : Exploded View"](#).
2. Perform DTC confirmation procedure. Refer to [SRC-82. "DTC Logic"](#).

Is DTC detected?

YES >> GO TO 1.  
NO >> INSPECTION END

A  
B  
C  
D  
E  
F  
G  
I  
J  
K  
L  
M  
N  
O  
P

SRC

# B1089 SEAT BELT PRE-TENSIONER LH

< DTC/CIRCUIT DIAGNOSIS >

## B1089 SEAT BELT PRE-TENSIONER LH

### Description

INFOID:000000005174261

In the case of a frontal collision that is more than the specified impact level, the air bag diagnosis sensor unit detects the deceleration caused by collision. It restrains the passenger with seat belt easing the stress on passengers chest with load limiter.

### DTC Logic

INFOID:000000005174262

### DTC DETECTION LOGIC

DTC	Display contents of CONSULT-III	DTC detecting condition	Possible cause
B1089	PRE-TEN FRONT LH [SHORT]	Seat belt pre-tensioner LH circuits are shorted to each other	<ul style="list-style-type: none"><li>• Disconnection of wiring harness and short</li><li>• Malfunction in seat belt pre-tensioner LH</li><li>• Malfunction in air bag diagnosis sensor unit</li></ul>

### DTC CONFIRMATION PROCEDURE

#### 1. CHECK SELF-DIAG RESULT

With CONSULT-III

1. Turn ignition switch ON.
2. Perform "AIR BAG" Self Diagnostic Result.

Without CONSULT-III

1. Turn ignition switch ON.
2. Check the air bag warning lamp status. Refer to [SRC-15. "Diagnosis with Air Bag Warning Lamp"](#).

#### NOTE:

SRS does not enter the diagnosis mode if no malfunction is detected in the user mode.

Is malfunctioning part detected?

- YES >> Refer to [SRC-84. "Diagnosis Procedure"](#).  
NO >> INSPECTION END

### Diagnosis Procedure

INFOID:000000005174263

#### WARNING:

- Before servicing, turn ignition switch OFF, disconnect battery negative terminal, and wait at least 3 minutes or more. (To discharge backup capacitor.)
- Never use unspecified tester or other measuring device.

#### 1. CHECK HARNESS CONNECTOR

Check the harness connector.

Is the inspection result normal?

- YES >> GO TO 2.  
NO >> Replace harness connector.

#### 2. CHECK WIRING HARNESS

Check the wiring harness externals.

Is the inspection result normal?

- YES >> GO TO 3.  
NO >> Replace wiring harness.

#### 3. REPLACE AIR BAG DIAGNOSIS SENSOR UNIT

1. Replace air bag diagnosis sensor unit. Refer to [SR-25. "Exploded View"](#).
2. Perform DTC confirmation procedure. Refer to [SRC-84. "DTC Logic"](#).

Is DTC detected?

- YES >> GO TO 4.  
NO >> INSPECTION END

## B1089 SEAT BELT PRE-TENSIONER LH

< DTC/CIRCUIT DIAGNOSIS >

---

### 4.REPLACE SEAT BELT PRE-TENSIONER

---

1. Replace seat belt pre-tensioner LH. Refer to [SB-6. "SEAT BELT RETRACTOR : Exploded View"](#).
2. Perform DTC confirmation procedure. Refer to [SRC-84. "DTC Logic"](#).

Is DTC detected?

YES >> GO TO 1.  
NO >> INSPECTION END

A  
B  
C  
D  
E  
F  
G  
I  
J  
K  
L  
M  
N  
O  
P

SRC

# B1090, B1091, B1092, B1093, B1094, B1095 DIAGNOSIS SENSOR UNIT

< DTC/CIRCUIT DIAGNOSIS >

## B1090, B1091, B1092, B1093, B1094, B1095 DIAGNOSIS SENSOR UNIT

### Description

INFOID:000000005174264

- It detects a shock that is more than the specified level and monitors whether the driver and passenger air bags, side air bag, curtain air bag, and pre-tensioner seat belts operate normally.
- It contains the "G" sensors for both frontal and side collisions and spare battery function in case of main battery damage in collision.

### DTC Logic

INFOID:000000005174265

### DTC DETECTION LOGIC

DTC	Display contents of CONSULT-III	DTC detecting condition	Possible cause
B1090 B1091 B1092 B1093 B0194 B1095	CONTROL UNIT	Air bag diagnosis sensor unit is malfunctioning	Malfunction in air bag diagnosis sensor unit

### DTC CONFIRMATION PROCEDURE

#### 1. CHECK SELF-DIAG RESULT

With CONSULT-III

1. Turn ignition switch ON.
2. Perform "AIR BAG" Self Diagnostic Result.

Without CONSULT-III

1. Turn ignition switch ON.
2. Check the air bag warning lamp status. Refer to [SRC-15, "Diagnosis with Air Bag Warning Lamp"](#).

#### NOTE:

SRS does not enter the diagnosis mode if no malfunction is detected in the user mode.

Is malfunctioning part detected?

- YES >> Refer to [SRC-86, "Diagnosis Procedure"](#).  
NO >> INSPECTION END

### Diagnosis Procedure

INFOID:000000005174266

#### WARNING:

- Before servicing, turn ignition switch OFF, disconnect battery negative terminal, and wait at least 3 minutes or more. (To discharge backup capacitor.)
- Never use unspecified tester or other measuring device.

#### 1. CHECK HARNESS CONNECTOR

Check the harness connector.

Is the inspection result normal?

- YES >> GO TO 2.  
NO >> Replace harness connectors.

#### 2. CHECK WIRING HARNESS

Check the wiring harness externals.

Is the inspection result normal?

- YES >> GO TO 3.  
NO >> Replace wiring harness.

#### 3. REPLACE AIR BAG DIAGNOSIS SENSOR UNIT

1. Replace air bag diagnosis sensor unit. Refer to [SR-25, "Exploded View"](#).
2. Perform DTC confirmation procedure. Refer to [SRC-86, "DTC Logic"](#).

# B1090, B1091, B1092, B1093, B1094, B1095 DIAGNOSIS SENSOR UNIT

< DTC/CIRCUIT DIAGNOSIS >

---

Is DTC detected?

YES >> GO TO 1.

NO >> INSPECTION END

A

B

C

D

E

F

G

**SRC**

I

J

K

L

M

N

O

P

# B1106, B1107, B1108, B1109, B1110, B1111 DIAGNOSIS SENSOR UNIT

< DTC/CIRCUIT DIAGNOSIS >

## B1106, B1107, B1108, B1109, B1110, B1111 DIAGNOSIS SENSOR UNIT

### Description

INFOID:000000005174267

- It detects a shock that is more than the specified level and monitors whether the driver and passenger air bags, side air bag, curtain air bag, and pre-tensioner seat belts operate normally.
- It contains the "G" sensors for both frontal and side collisions and spare battery function in case of main battery damage in collision.

### DTC Logic

INFOID:000000005174268

### DTC DETECTION LOGIC

DTC	Display contents of CONSULT-III	DTC detecting condition	Possible cause
B1106 B1107 B1108 B1109 B1110 B1111	CONTROL UNIT	Air bag diagnosis sensor unit is malfunctioning	Malfunction in air bag diagnosis sensor unit

### DTC CONFIRMATION PROCEDURE

#### 1. CHECK SELF-DIAG RESULT

With CONSULT-III

1. Turn ignition switch ON.
2. Perform "AIR BAG" Self Diagnostic Result.

Without CONSULT-III

1. Turn ignition switch ON.
2. Check the air bag warning lamp status. Refer to [SRC-15, "Diagnosis with Air Bag Warning Lamp"](#).

#### NOTE:

SRS does not enter the diagnosis mode if no malfunction is detected in the user mode.

Is malfunctioning part detected?

- YES >> Refer to [SRC-88, "Diagnosis Procedure"](#).  
NO >> INSPECTION END

### Diagnosis Procedure

INFOID:000000005174269

#### WARNING:

- Before servicing, turn ignition switch OFF, disconnect battery negative terminal, and wait at least 3 minutes or more. (To discharge backup capacitor.)
- Never use unspecified tester or other measuring device.

#### 1. CHECK HARNESS CONNECTOR

Check the harness connector.

Is the inspection result normal?

- YES >> GO TO 2.  
NO >> Replace harness connectors.

#### 2. CHECK WIRING HARNESS

Check the wiring harness externals.

Is the inspection result normal?

- YES >> GO TO 3.  
NO >> Replace wiring harness.

#### 3. REPLACE AIR BAG DIAGNOSIS SENSOR UNIT

1. Replace air bag diagnosis sensor unit. Refer to [SR-25, "Exploded View"](#).
2. Perform DTC confirmation procedure. Refer to [SRC-88, "DTC Logic"](#).



# B1106, B1107, B1108, B1109, B1110, B1111 DIAGNOSIS SENSOR UNIT

< DTC/CIRCUIT DIAGNOSIS >

---

Is DTC detected?

YES >> GO TO 1.

NO >> INSPECTION END

A

B

C

D

E

F

G

**SRC**

I

J

K

L

M

N

O

P

# B1113, B1114 SATELLITE SENSOR RH

< DTC/CIRCUIT DIAGNOSIS >

## B1113, B1114 SATELLITE SENSOR RH

### Description

INFOID:000000005174270

When air bag diagnosis sensor unit defines both signal voltage of the "G" sensor and the safing algorithm to be that of collision which is more than the specified level, the driving circuit switches on and feeds the electric ignitor of both the front side air bag and side curtain air bag.

### DTC Logic

INFOID:000000005174271

### DTC DETECTION LOGIC

DTC	Display contents of CONSULT-III	DTC detecting condition	Possible cause
B1113 B1114	SATELLITE SENS RH [UNIT FAIL]	Satellite sensor RH is malfunctioning	<ul style="list-style-type: none"><li>• Disconnection of wiring harness</li><li>• Malfunction in satellite sensor RH</li><li>• Malfunction in air bag diagnosis sensor unit</li></ul>

### DTC CONFIRMATION PROCEDURE

#### 1. CHECK SELF-DIAG RESULT

With CONSULT-III

1. Turn ignition switch ON.
2. Perform "AIR BAG" Self Diagnostic Result.

Without CONSULT-III

1. Turn ignition switch ON.
2. Check the air bag warning lamp status. Refer to [SRC-15, "Diagnosis with Air Bag Warning Lamp"](#).

#### NOTE:

SRS does not enter the diagnosis mode if no malfunction is detected in the user mode.

#### Is malfunctioning part detected?

- YES >> Refer to [SRC-90, "Diagnosis Procedure"](#).  
NO >> INSPECTION END

### Diagnosis Procedure

INFOID:000000005174272

#### WARNING:

- Before servicing, turn ignition switch OFF, disconnect battery negative terminal, and wait at least 3 minutes or more. (To discharge backup capacitor.)
- Never use unspecified tester or other measuring device.

#### 1. CHECK HARNESS CONNECTOR

Check the harness connector.

#### Is the inspection result normal?

- YES >> GO TO 2.  
NO >> Replace harness connector.

#### 2. CHECK WIRING HARNESS

Check the wiring harness externals.

#### Is the inspection result normal?

- YES >> GO TO 3.  
NO >> Replace wiring harness.

#### 3. REPLACE AIR BAG DIAGNOSIS SENSOR UNIT

1. Replace air bag diagnosis sensor unit. Refer to [SR-25, "Exploded View"](#).
2. Perform DTC confirmation procedure. Refer to [SRC-90, "DTC Logic"](#).

#### Is DTC detected?

- YES >> GO TO 4.  
NO >> INSPECTION END

## B1113, B1114 SATELLITE SENSOR RH

< DTC/CIRCUIT DIAGNOSIS >

---

### 4.REPLACE SATELLITE SENSOR

---

1. Replace satellite sensor RH. Refer to [SR-23, "Exploded View"](#).
2. Perform DTC confirmation procedure. Refer to [SRC-90, "DTC Logic"](#).

Is DTC detected?

YES >> GO TO 1.  
NO >> INSPECTION END

A  
B  
C  
D  
E  
F  
G  
I  
J  
K  
L  
M  
N  
O  
P

SRC

# B1115, B1116 SATELLITE SENSOR RH

< DTC/CIRCUIT DIAGNOSIS >

## B1115, B1116 SATELLITE SENSOR RH

### Description

INFOID:000000005174273

When air bag diagnosis sensor unit defines both signal voltage of the "G" sensor and the safing algorithm to be that of collision which is more than the specified level, the driving circuit switches on and feeds the electric ignitor of both the front side air bag and side curtain air bag.

### DTC Logic

INFOID:000000005174274

### DTC DETECTION LOGIC

DTC	Display contents of CONSULT-III	DTC detecting condition	Possible cause
B1115 B1116	SATELLITE SENS RH [COMM FAIL] [UNMATCH]	Satellite sensor RH is malfunctioning or out of the specified specification	<ul style="list-style-type: none"><li>• Disconnection of wiring harness</li><li>• Malfunction in satellite sensor RH</li><li>• Malfunction in air bag diagnosis sensor unit</li></ul>

### DTC CONFIRMATION PROCEDURE

#### 1. CHECK SELF-DIAG RESULT

With CONSULT-III

1. Turn ignition switch ON.
2. Perform "AIR BAG" Self Diagnostic Result.

Without CONSULT-III

1. Turn ignition switch ON.
2. Check the air bag warning lamp status. Refer to [SRC-15. "Diagnosis with Air Bag Warning Lamp"](#).

#### NOTE:

SRS does not enter the diagnosis mode if no malfunction is detected in the user mode.

Is malfunctioning part detected?

- YES >> Refer to [SRC-92. "Diagnosis Procedure"](#).  
NO >> INSPECTION END

### Diagnosis Procedure

INFOID:000000005174275

#### WARNING:

- Before servicing, turn ignition switch OFF, disconnect battery negative terminal, and wait at least 3 minutes or more. (To discharge backup capacitor.)
- Never use unspecified tester or other measuring device.

#### 1. CHECK HARNESS CONNECTOR

Check the harness connector.

Is the inspection result normal?

- YES >> GO TO 2.  
NO >> Replace harness connector.

#### 2. CHECK WIRING HARNESS

Check the wiring harness externals.

Is the inspection result normal?

- YES >> GO TO 3.  
NO >> Replace wiring harness.

#### 3. REPLACE AIR BAG DIAGNOSIS SENSOR UNIT

1. Replace air bag diagnosis sensor unit. Refer to [SR-25. "Exploded View"](#).
2. Perform DTC confirmation procedure. Refer to [SRC-92. "DTC Logic"](#).

Is DTC detected?

- YES >> GO TO 4.  
NO >> INSPECTION END

## B1115, B1116 SATELLITE SENSOR RH

< DTC/CIRCUIT DIAGNOSIS >

---

### 4. REPLACE SATELLITE SENSOR

---

1. Replace satellite sensor RH. Refer to [SR-23, "Exploded View"](#).
2. Perform DTC confirmation procedure. Refer to [SRC-92, "DTC Logic"](#).

Is DTC detected?

YES >> GO TO 1.  
NO >> INSPECTION END

A  
B  
C  
D  
E  
F  
G  
I  
J  
K  
L  
M  
N  
O  
P

SRC

# B1118, B1119 SATELLITE SENSOR LH

< DTC/CIRCUIT DIAGNOSIS >

## B1118, B1119 SATELLITE SENSOR LH

### Description

INFOID:000000005174276

When air bag diagnosis sensor unit defines both signal voltage of the "G" sensor and the safing algorithm to be that of collision which is more than the specified level, the driving circuit switches on and feeds the electric ignitor of both the front side air bag and side curtain air bag.

### DTC Logic

INFOID:000000005174277

### DTC DETECTION LOGIC

DTC	Display contents of CONSULT-III	DTC detecting condition	Possible cause
B1118 B1119	SATELLITE SENS LH [UNIT FAIL]	Satellite sensor LH is malfunctioning	<ul style="list-style-type: none"><li>• Disconnection of wiring harness</li><li>• Malfunction in satellite sensor LH</li><li>• Malfunction in air bag diagnosis sensor unit</li></ul>

### DTC CONFIRMATION PROCEDURE

#### 1. CHECK SELF-DIAG RESULT

With CONSULT-III

1. Turn ignition switch ON.
2. Perform "AIR BAG" Self Diagnostic Result.

Without CONSULT-III

1. Turn ignition switch ON.
2. Check the air bag warning lamp status. Refer to [SRC-15. "Diagnosis with Air Bag Warning Lamp"](#).

#### NOTE:

SRS does not enter the diagnosis mode if no malfunction is detected in the user mode.

Is malfunctioning part detected?

- YES >> Refer to [SRC-94. "Diagnosis Procedure"](#).  
NO >> INSPECTION END

### Diagnosis Procedure

INFOID:000000005174278

#### WARNING:

- Before servicing, turn ignition switch OFF, disconnect battery negative terminal, and wait at least 3 minutes or more. (To discharge backup capacitor.)
- Never use unspecified tester or other measuring device.

#### 1. CHECK HARNESS CONNECTOR

Check the harness connector.

Is the inspection result normal?

- YES >> GO TO 2.  
NO >> Replace harness connector.

#### 2. CHECK WIRING HARNESS

Check the wiring harness externals.

Is the inspection result normal?

- YES >> GO TO 3.  
NO >> Replace wiring harness.

#### 3. REPLACE AIR BAG DIAGNOSIS SENSOR UNIT

1. Replace air bag diagnosis sensor unit. Refer to [SR-25. "Exploded View"](#).
2. Perform DTC confirmation procedure. Refer to [SRC-94. "DTC Logic"](#).

Is DTC detected?

- YES >> GO TO 4.  
NO >> INSPECTION END

## B1118, B1119 SATELLITE SENSOR LH

< DTC/CIRCUIT DIAGNOSIS >

---

### 4.REPLACE SATELLITE SENSOR

---

1. Replace satellite sensor LH. Refer to [SR-23, "Exploded View"](#).
2. Perform DTC confirmation procedure. Refer to [SRC-94, "DTC Logic"](#)

Is DTC detected?

YES >> GO TO 1.  
NO >> INSPECTION END

A  
B  
C  
D  
E  
F  
G  
I  
J  
K  
L  
M  
N  
O  
P

SRC

# B1120, B1121 SATELLITE SENSOR LH

< DTC/CIRCUIT DIAGNOSIS >

## B1120, B1121 SATELLITE SENSOR LH

### Description

INFOID:000000005174279

When air bag diagnosis sensor unit defines both signal voltage of the "G" sensor and the safing algorithm to be that of collision which is more than the specified level, the driving circuit switches on and feeds the electric ignitor of both the front side air bag and side curtain air bag.

### DTC Logic

INFOID:000000005174280

### DTC DETECTION LOGIC

DTC	Display contents of CONSULT-III	DTC detecting condition	Possible cause
B1120 B1121	SATELLITE SENS LH [COMM FAIL] [UNMATCH]	Satellite sensor LH is malfunctioning or out of the specified specification	<ul style="list-style-type: none"><li>• Disconnection of wiring harness</li><li>• Malfunction in satellite sensor LH</li><li>• Malfunction in air bag diagnosis sensor unit</li></ul>

### DTC CONFIRMATION PROCEDURE

#### 1. CHECK SELF-DIAG RESULT

With CONSULT-III

1. Turn ignition switch ON.
2. Perform "AIR BAG" Self Diagnostic Result.

Without CONSULT-III

1. Turn ignition switch ON.
2. Check the air bag warning lamp status. Refer to [SRC-15, "Diagnosis with Air Bag Warning Lamp"](#).

#### NOTE:

SRS does not enter the diagnosis mode if no malfunction is detected in the user mode.

#### Is malfunctioning part detected?

- YES >> Refer to [SRC-96, "Diagnosis Procedure"](#).  
NO >> INSPECTION END

### Diagnosis Procedure

INFOID:000000005174281

#### WARNING:

- Before servicing, turn ignition switch OFF, disconnect battery negative terminal, and wait at least 3 minutes or more. (To discharge backup capacitor.)
- Never use unspecified tester or other measuring device.

#### 1. CHECK HARNESS CONNECTOR

Check the harness connector.

#### Is the inspection result normal?

- YES >> GO TO 2.  
NO >> Replace harness connector.

#### 2. CHECK WIRING HARNESS

Check the wiring harness externals.

#### Is the inspection result normal?

- YES >> GO TO 3.  
NO >> Replace wiring harness.

#### 3. REPLACE AIR BAG DIAGNOSIS SENSOR UNIT

1. Replace air bag diagnosis sensor unit. Refer to [SR-25, "Exploded View"](#).
2. Perform DTC confirmation procedure. Refer to [SRC-96, "DTC Logic"](#).

#### Is DTC detected?

- YES >> GO TO 4.  
NO >> INSPECTION END



## B1120, B1121 SATELLITE SENSOR LH

< DTC/CIRCUIT DIAGNOSIS >

---

### 4.REPLACE SATELLITE SENSOR

---

1. Replace satellite sensor LH. Refer to [SR-23, "Exploded View"](#).
2. Perform DTC confirmation procedure. Refer to [SRC-96, "DTC Logic"](#).

Is DTC detected?

YES >> GO TO 1.  
NO >> INSPECTION END

A  
B  
C  
D  
E  
F  
G  
I  
J  
K  
L  
M  
N  
O  
P

SRC

# B1122, B1123, B1124, B1125, B1126, B1127 DIAGNOSIS SENSOR UNIT

< DTC/CIRCUIT DIAGNOSIS >

## B1122, B1123, B1124, B1125, B1126, B1127 DIAGNOSIS SENSOR UNIT

### Description

INFOID:000000005174282

- It detects a shock that is more than the specified level and monitors whether the driver and passenger air bags, side air bag, curtain air bag, and pre-tensioner seat belts operate normally.
- It contains the "G" sensors for both frontal and side collisions and spare battery function in case of main battery damage in collision.

### DTC Logic

INFOID:000000005174283

### DTC DETECTION LOGIC

DTC	Display contents of CONSULT-III	DTC detecting condition	Possible cause
B1122 B1123 B1124 B1125 B1126 B1127	CONTROL UNIT	Air bag diagnosis sensor unit is malfunctioning	Malfunction in air bag diagnosis sensor unit

### DTC CONFIRMATION PROCEDURE

#### 1. CHECK SELF-DIAG RESULT

With CONSULT-III

1. Turn ignition switch ON.
2. Perform "AIR BAG" Self Diagnostic Result.

Without CONSULT-III

1. Turn ignition switch ON.
2. Check the air bag warning lamp status. Refer to [SRC-15, "Diagnosis with Air Bag Warning Lamp"](#).

#### NOTE:

SRS does not enter the diagnosis mode if no malfunction is detected in the user mode.

Is malfunctioning part detected?

YES >> Refer to [SRC-98, "Diagnosis Procedure"](#).

NO >> INSPECTION END

### Diagnosis Procedure

INFOID:000000005174284

#### WARNING:

- Before servicing, turn ignition switch OFF, disconnect battery negative terminal, and wait at least 3 minutes or more. (To discharge backup capacitor.)
- Never use unspecified tester or other measuring device.

#### 1. CHECK HARNESS CONNECTOR

Check the harness connector.

Is the inspection result normal?

YES >> GO TO 2.

NO >> Replace harness connectors.

#### 2. CHECK WIRING HARNESS

Check the wiring harness externals.

Is the inspection result normal?

YES >> GO TO 3.

NO >> Replace wiring harness.

#### 3. REPLACE AIR BAG DIAGNOSIS SENSOR UNIT

1. Replace air bag diagnosis sensor unit. Refer to [SR-25, "Exploded View"](#).
2. Perform DTC confirmation procedure. Refer to [SRC-98, "DTC Logic"](#).

# B1122, B1123, B1124, B1125, B1126, B1127 DIAGNOSIS SENSOR UNIT

< DTC/CIRCUIT DIAGNOSIS >

---

Is DTC detected?

YES >> GO TO 1.

NO >> INSPECTION END

A

B

C

D

E

F

G

**SRC**

I

J

K

L

M

N

O

P

# B1129 SIDE AIR BAG MODULE RH

< DTC/CIRCUIT DIAGNOSIS >

## B1129 SIDE AIR BAG MODULE RH

### Description

INFOID:000000005174285

In case of frontal collision where acceleration is more than the specified level, the ignition materials are ignited by electric ignition system. The system burns the gas generating materials resulting in a chemical reaction. This generates hot gases that flow into the air bag through a filter and expand the bag.

### DTC Logic

INFOID:000000005174286

### DTC DETECTION LOGIC

DTC	Display contents of CONSULT-III	DTC detecting condition	Possible cause
B1129	SIDE MODULE RH [OPEN]	Side air bag module RH circuit is open	<ul style="list-style-type: none"><li>• Disconnection of wiring harness and open</li><li>• Malfunction in side air bag module RH</li><li>• Malfunction in air bag diagnosis sensor unit</li></ul>

### DTC CONFIRMATION PROCEDURE

#### 1. CHECK SELF-DIAG RESULT

With CONSULT-III

1. Turn ignition switch ON.
2. Perform "AIR BAG" Self Diagnostic Result.

Without CONSULT-III

1. Turn ignition switch ON.
2. Check the air bag warning lamp status. [SRC-15. "Diagnosis with Air Bag Warning Lamp"](#)

#### NOTE:

SRS does not enter the diagnosis mode if no malfunction is detected in the user mode.

Is malfunctioning part detected?

- YES >> Refer to [SRC-100. "Diagnosis Procedure"](#).  
NO >> INSPECTION END

### Diagnosis Procedure

INFOID:000000005174287

#### WARNING:

- Before servicing, turn ignition switch OFF, disconnect battery negative terminal, and wait at least 3 minutes or more. (To discharge backup capacitor.)
- Never use unspecified tester or other measuring device.

#### 1. CHECK HARNESS CONNECTOR

Check the harness connector.

Is the inspection result normal?

- YES >> GO TO 2.  
NO >> Replace harness connector.

#### 2. CHECK WIRING HARNESS

Check the wiring harness externals.

Is the inspection result normal?

- YES >> GO TO 3.  
NO >> Replace wiring harness.

#### 3. REPLACE AIR BAG DIAGNOSIS SENSOR UNIT

1. Replace air bag diagnosis sensor unit. Refer to [SR-25. "Exploded View"](#).
2. Perform DTC confirmation procedure. Refer to [SRC-100. "DTC Logic"](#).

Is DTC detected?

- YES >> GO TO 4.  
NO >> INSPECTION END

## B1129 SIDE AIR BAG MODULE RH

< DTC/CIRCUIT DIAGNOSIS >

---

### 4. REPLACE SIDE AIR BAG MODULE

---

1. Replace side air bag module RH. Refer to [SE-129, "Exploded View"](#).
2. Perform DTC confirmation procedure. Refer to [SRC-100, "DTC Logic"](#).

Is DTC detected?

YES >> GO TO 1.  
NO >> INSPECTION END

A  
B  
C  
D  
E  
F  
G  
I  
J  
K  
L  
M  
N  
O  
P

SRC

# B1130 SIDE AIR BAG MODULE RH

< DTC/CIRCUIT DIAGNOSIS >

## B1130 SIDE AIR BAG MODULE RH

### Description

INFOID:000000005174288

In case of frontal collision where acceleration is more than the specified level, the ignition materials are ignited by electric ignition system. The system burns the gas generating materials resulting in a chemical reaction. This generates hot gases that flow into the air bag through a filter and expand the bag.

### DTC Logic

INFOID:000000005174289

### DTC DETECTION LOGIC

DTC	Display contents of CONSULT-III	DTC detecting condition	Possible cause
B1130	SIDE MODULE RH [VB-SHORT]	Side air bag module RH circuit is shorted to power supply circuit	<ul style="list-style-type: none"><li>• Disconnection of wiring harness and short</li><li>• Malfunction in side air bag module RH</li><li>• Malfunction in air bag diagnosis sensor unit</li></ul>

### DTC CONFIRMATION PROCEDURE

#### 1. CHECK SELF-DIAG RESULT

With CONSULT-III

1. Turn ignition switch ON.
2. Perform "AIR BAG" Self Diagnostic Result.

Without CONSULT-III

1. Turn ignition switch ON.
2. Check the air bag warning lamp status. Refer to [SRC-15. "Diagnosis with Air Bag Warning Lamp"](#).

#### NOTE:

SRS does not enter the diagnosis mode if no malfunction is detected in the user mode.

Is malfunctioning part detected?

- YES >> Refer to [SRC-102. "Diagnosis Procedure"](#).  
NO >> INSPECTION END

### Diagnosis Procedure

INFOID:000000005174290

#### WARNING:

- Before servicing, turn ignition switch OFF, disconnect battery negative terminal, and wait at least 3 minutes or more. (To discharge backup capacitor.)
- Never use unspecified tester or other measuring device.

#### 1. CHECK HARNESS CONNECTOR

Check the harness connector.

Is the inspection result normal?

- YES >> GO TO 2.  
NO >> Replace harness connector.

#### 2. CHECK WIRING HARNESS

Check the wiring harness externals.

Is the inspection result normal?

- YES >> GO TO 3.  
NO >> Replace wiring harness.

#### 3. REPLACE AIR BAG DIAGNOSIS SENSOR UNIT

1. Replace air bag diagnosis sensor unit. Refer to [SR-25. "Exploded View"](#).
2. Perform DTC confirmation procedure. Refer to [SRC-102. "DTC Logic"](#).

Is DTC detected?

- YES >> GO TO 4.  
NO >> INSPECTION END

## B1130 SIDE AIR BAG MODULE RH

< DTC/CIRCUIT DIAGNOSIS >

---

### 4. REPLACE SIDE AIR BAG MODULE

---

1. Replace side air bag module RH. Refer to [SE-129, "Exploded View"](#).
2. Perform DTC confirmation procedure. Refer to [SRC-102, "DTC Logic"](#).

Is DTC detected?

YES >> GO TO 1.  
NO >> INSPECTION END

A  
B  
C  
D  
E  
F  
G  
I  
J  
K  
L  
M  
N  
O  
P

SRC

# B1131 SIDE AIR BAG MODULE RH

< DTC/CIRCUIT DIAGNOSIS >

## B1131 SIDE AIR BAG MODULE RH

### Description

INFOID:000000005174291

In case of frontal collision where acceleration is more than the specified level, the ignition materials are ignited by electric ignition system. The system burns the gas generating materials resulting in a chemical reaction. This generates hot gases that flow into the air bag through a filter and expand the bag.

### DTC Logic

INFOID:000000005174292

### DTC DETECTION LOGIC

DTC	Display contents of CONSULT-III	DTC detecting condition	Possible cause
B1131	SIDE MODULE RH [GND-SHORT]	Side air bag module RH circuit is shorted to ground	<ul style="list-style-type: none"><li>• Disconnection of wiring harness and short</li><li>• Malfunction in side air bag module RH</li><li>• Malfunction in air bag diagnosis sensor unit</li></ul>

### DTC CONFIRMATION PROCEDURE

#### 1. CHECK SELF-DIAG RESULT

With CONSULT-III

1. Turn ignition switch ON.
2. Perform "AIR BAG" Self Diagnostic Result.

Without CONSULT-III

1. Turn ignition switch ON.
2. Check the air bag warning lamp status. Refer to [SRC-15. "Diagnosis with Air Bag Warning Lamp"](#).

#### NOTE:

SRS does not enter the diagnosis mode if no malfunction is detected in the user mode.

Is malfunctioning part detected?

- YES >> Refer to [SRC-104. "Diagnosis Procedure"](#).  
NO >> INSPECTION END

### Diagnosis Procedure

INFOID:000000005174293

#### WARNING:

- Before servicing, turn ignition switch OFF, disconnect battery negative terminal, and wait at least 3 minutes or more. (To discharge backup capacitor.)
- Never use unspecified tester or other measuring device.

#### 1. CHECK HARNESS CONNECTOR

Check the harness connector.

Is the inspection result normal?

- YES >> GO TO 2.  
NO >> Replace harness connector.

#### 2. CHECK WIRING HARNESS

Check the wiring harness externals.

Is the inspection result normal?

- YES >> GO TO 3.  
NO >> Replace wiring harness.

#### 3. REPLACE AIR BAG DIAGNOSIS SENSOR UNIT

1. Replace air bag diagnosis sensor unit. Refer to [SR-25. "Exploded View"](#).
2. Perform DTC confirmation procedure. Refer to [SRC-104. "DTC Logic"](#).

Is DTC detected?

- YES >> GO TO 4.  
NO >> INSPECTION END



## B1131 SIDE AIR BAG MODULE RH

< DTC/CIRCUIT DIAGNOSIS >

---

### 4. REPLACE SIDE AIR BAG MODULE

---

1. Replace side air bag module RH. Refer to [SE-129, "Exploded View"](#).
2. Perform DTC confirmation procedure. Refer to [SRC-104, "DTC Logic"](#).

Is DTC detected?

YES >> GO TO 1.  
NO >> INSPECTION END

A  
B  
C  
D  
E  
F  
G  
I  
J  
K  
L  
M  
N  
O  
P

SRC

# B1132 SIDE AIR BAG MODULE RH

< DTC/CIRCUIT DIAGNOSIS >

## B1132 SIDE AIR BAG MODULE RH

### Description

INFOID:000000005174294

In case of frontal collision where acceleration is more than the specified level, the ignition materials are ignited by electric ignition system. The system burns the gas generating materials resulting in a chemical reaction. This generates hot gases that flow into the air bag through a filter and expand the bag.

### DTC Logic

INFOID:000000005174295

### DTC DETECTION LOGIC

DTC	Display contents of CONSULT-III	DTC detecting condition	Possible cause
B1132	SIDE MODULE RH [SHORT]	Side air bag module RH circuits are shorted to each other	<ul style="list-style-type: none"><li>• Disconnection of wiring harness and short</li><li>• Malfunction in side air bag module RH</li><li>• Malfunction in air bag diagnosis sensor unit</li></ul>

### DTC CONFIRMATION PROCEDURE

#### 1. CHECK SELF-DIAG RESULT

With CONSULT-III

1. Turn ignition switch ON.
2. Perform "AIR BAG" Self Diagnostic Result.

Without CONSULT-III

1. Turn ignition switch ON.
2. Check the air bag warning lamp status. Refer to [SRC-15, "Diagnosis with Air Bag Warning Lamp"](#).

#### NOTE:

SRS does not enter the diagnosis mode if no malfunction is detected in the user mode.

Is malfunctioning part detected?

- YES >> Refer to [SRC-106, "Diagnosis Procedure"](#).  
NO >> INSPECTION END

### Diagnosis Procedure

INFOID:000000005174296

#### WARNING:

- Before servicing, turn ignition switch OFF, disconnect battery negative terminal, and wait at least 3 minutes or more. (To discharge backup capacitor.)
- Never use unspecified tester or other measuring device.

#### 1. CHECK HARNESS CONNECTOR

Check the harness connector.

Is the inspection result normal?

- YES >> GO TO 2.  
NO >> Replace harness connector.

#### 2. CHECK WIRING HARNESS

Check the wiring harness externals.

Is the inspection result normal?

- YES >> GO TO 3.  
NO >> Replace wiring harness.

#### 3. REPLACE AIR BAG DIAGNOSIS SENSOR UNIT

1. Replace air bag diagnosis sensor unit. Refer to [SR-25, "Exploded View"](#).
2. Perform DTC confirmation procedure. Refer to [SRC-106, "DTC Logic"](#).

Is DTC detected?

- YES >> GO TO 4.  
NO >> INSPECTION END

## B1132 SIDE AIR BAG MODULE RH

< DTC/CIRCUIT DIAGNOSIS >

---

### 4. REPLACE SIDE AIR BAG MODULE

---

1. Replace side air bag module RH. Refer to [SE-129, "Exploded View"](#).
2. Perform DTC confirmation procedure. Refer to [SRC-106, "DTC Logic"](#).

Is DTC detected?

YES >> GO TO 1.  
NO >> INSPECTION END

A  
B  
C  
D  
E  
F  
G  
I  
J  
K  
L  
M  
N  
O  
P

SRC

# B1134 SIDE AIR BAG MODULE LH

< DTC/CIRCUIT DIAGNOSIS >

## B1134 SIDE AIR BAG MODULE LH

### Description

INFOID:000000005174297

In case of frontal collision where acceleration is more than the specified level, the ignition materials are ignited by electric ignition system. The system burns the gas generating materials resulting in a chemical reaction. This generates hot gases that flow into the air bag through a filter and expand the bag.

### DTC Logic

INFOID:000000005174298

### DTC DETECTION LOGIC

DTC	Display contents of CONSULT-III	DTC detecting condition	Possible cause
B1134	SIDE MODULE LH [OPEN]	Side air bag module LH circuit is open	<ul style="list-style-type: none"><li>• Disconnection of wiring harness and open</li><li>• Malfunction in side air bag module LH</li><li>• Malfunction in air bag diagnosis sensor unit</li></ul>

### DTC CONFIRMATION PROCEDURE

#### 1. CHECK SELF-DIAG RESULT

With CONSULT-III

1. Turn ignition switch ON.
2. Perform "AIR BAG" Self Diagnostic Result.

Without CONSULT-III

1. Turn ignition switch ON.
2. Check the air bag warning lamp status. Refer to [SRC-15. "Diagnosis with Air Bag Warning Lamp"](#).

#### NOTE:

SRS does not enter the diagnosis mode if no malfunction is detected in the user mode.

Is malfunctioning part detected?

- YES >> Refer to [SRC-108. "Diagnosis Procedure"](#).  
NO >> INSPECTION END

### Diagnosis Procedure

INFOID:000000005174299

#### WARNING:

- Before servicing, turn ignition switch OFF, disconnect battery negative terminal, and wait at least 3 minutes or more. (To discharge backup capacitor.)
- Never use unspecified tester or other measuring device.

#### 1. CHECK HARNESS CONNECTOR

Check the harness connector.

Is the inspection result normal?

- YES >> GO TO 2.  
NO >> Replace harness connector.

#### 2. CHECK WIRING HARNESS

Check the wiring harness externals.

Is the inspection result normal?

- YES >> GO TO 3.  
NO >> Replace wiring harness.

#### 3. REPLACE AIR BAG DIAGNOSIS SENSOR UNIT

1. Replace air bag diagnosis sensor unit. Refer to [SR-25. "Exploded View"](#).
2. Perform DTC confirmation procedure. Refer to [SRC-108. "DTC Logic"](#).

Is DTC detected?

- YES >> GO TO 4.  
NO >> INSPECTION END

## B1134 SIDE AIR BAG MODULE LH

< DTC/CIRCUIT DIAGNOSIS >

---

### 4. REPLACE SIDE AIR BAG MODULE

---

1. Replace side air bag module LH. Refer to [SE-129, "Exploded View"](#).
2. Perform DTC confirmation procedure. Refer to [SRC-108, "DTC Logic"](#).

Is DTC detected?

YES >> GO TO 1.  
NO >> INSPECTION END

A  
B  
C  
D  
E  
F  
G  
I  
J  
K  
L  
M  
N  
O  
P

SRC

# B1135 SIDE AIR BAG MODULE LH

< DTC/CIRCUIT DIAGNOSIS >

## B1135 SIDE AIR BAG MODULE LH

### Description

INFOID:000000005174300

In case of frontal collision where acceleration is more than the specified level, the ignition materials are ignited by electric ignition system. The system burns the gas generating materials resulting in a chemical reaction. This generates hot gases that flow into the air bag through a filter and expand the bag.

### DTC Logic

INFOID:000000005174301

### DTC DETECTION LOGIC

DTC	Display contents of CONSULT-III	DTC detecting condition	Possible cause
B1135	SIDE MODULE LH [VB-SHORT]	Side air bag module LH circuit is shorted to power supply circuit	<ul style="list-style-type: none"><li>• Disconnection of wiring harness and short</li><li>• Malfunction in side air bag module LH</li><li>• Malfunction in air bag diagnosis sensor unit</li></ul>

### DTC CONFIRMATION PROCEDURE

#### 1. CHECK SELF-DIAG RESULT

With CONSULT-III

1. Turn ignition switch ON.
2. Perform "AIR BAG" Self Diagnostic Result.

Without CONSULT-III

1. Turn ignition switch ON.
2. Check the air bag warning lamp status. Refer to [SRC-15. "Diagnosis with Air Bag Warning Lamp"](#).

#### NOTE:

SRS does not enter the diagnosis mode if no malfunction is detected in the user mode.

Is malfunctioning part detected?

- YES >> Refer to [SRC-110. "Diagnosis Procedure"](#).  
NO >> INSPECTION END

### Diagnosis Procedure

INFOID:000000005174302

#### WARNING:

- Before servicing, turn ignition switch OFF, disconnect battery negative terminal, and wait at least 3 minutes or more. (To discharge backup capacitor.)
- Never use unspecified tester or other measuring device.

#### 1. CHECK HARNESS CONNECTOR

Check the harness connector.

Is the inspection result normal?

- YES >> GO TO 2.  
NO >> Replace harness connector.

#### 2. CHECK WIRING HARNESS

Check the wiring harness externals.

Is the inspection result normal?

- YES >> GO TO 3.  
NO >> Replace wiring harness.

#### 3. REPLACE AIR BAG DIAGNOSIS SENSOR UNIT

1. Replace air bag diagnosis sensor unit. Refer to [SR-25. "Exploded View"](#).
2. Perform DTC confirmation procedure. Refer to [SRC-110. "DTC Logic"](#).

Is DTC detected?

- YES >> GO TO 4.  
NO >> INSPECTION END

# B1135 SIDE AIR BAG MODULE LH

< DTC/CIRCUIT DIAGNOSIS >

---

## 4.REPLACE SIDE AIR BAG MODULE

---

1. Replace side air bag module LH. Refer to [SE-129, "Exploded View"](#).
2. Perform DTC confirmation procedure. Refer to [SRC-110, "DTC Logic"](#).

Is DTC detected?

YES >> GO TO 1.  
NO >> INSPECTION END

A  
B  
C  
D  
E  
F  
G  
I  
J  
K  
L  
M  
N  
O  
P

**SRC**

# B1136 SIDE AIR BAG MODULE LH

< DTC/CIRCUIT DIAGNOSIS >

## B1136 SIDE AIR BAG MODULE LH

### Description

INFOID:000000005174303

In case of frontal collision where acceleration is more than the specified level, the ignition materials are ignited by electric ignition system. The system burns the gas generating materials resulting in a chemical reaction. This generates hot gases that flow into the air bag through a filter and expand the bag.

### DTC Logic

INFOID:000000005174304

### DTC DETECTION LOGIC

DTC	Display contents of CONSULT-III	DTC detecting condition	Possible cause
B1136	SIDE MODULE LH [GND-SHORT]	Side air bag module LH circuit is shorted to ground	<ul style="list-style-type: none"><li>• Disconnection of wiring harness and short</li><li>• Malfunction in side air bag module LH</li><li>• Malfunction in air bag diagnosis sensor unit</li></ul>

### DTC CONFIRMATION PROCEDURE

#### 1. CHECK SELF-DIAG RESULT

With CONSULT-III

1. Turn ignition switch ON.
2. Perform "AIR BAG" Self Diagnostic Result.

Without CONSULT-III

1. Turn ignition switch ON.
2. Check the air bag warning lamp status. Refer to [SRC-15. "Diagnosis with Air Bag Warning Lamp"](#).

#### NOTE:

SRS does not enter the diagnosis mode if no malfunction is detected in the user mode.

Is malfunctioning part detected?

- YES >> Refer to [SRC-112. "Diagnosis Procedure"](#).  
NO >> INSPECTION END

### Diagnosis Procedure

INFOID:000000005174305

#### WARNING:

- Before servicing, turn ignition switch OFF, disconnect battery negative terminal, and wait at least 3 minutes or more. (To discharge backup capacitor.)
- Never use unspecified tester or other measuring device.

#### 1. CHECK HARNESS CONNECTOR

Check the harness connector.

Is the inspection result normal?

- YES >> GO TO 2.  
NO >> Replace harness connector.

#### 2. CHECK WIRING HARNESS

Check the wiring harness externals.

Is the inspection result normal?

- YES >> GO TO 3.  
NO >> Replace wiring harness.

#### 3. REPLACE AIR BAG DIAGNOSIS SENSOR UNIT

1. Replace air bag diagnosis sensor unit. Refer to [SR-25. "Exploded View"](#).
2. Perform DTC confirmation procedure. Refer to [SRC-112. "DTC Logic"](#).

Is DTC detected?

- YES >> GO TO 4.  
NO >> INSPECTION END



## B1136 SIDE AIR BAG MODULE LH

< DTC/CIRCUIT DIAGNOSIS >

---

### 4. REPLACE SIDE AIR BAG MODULE

---

1. Replace side air bag module LH. Refer to [SE-129, "Exploded View"](#).
2. Perform DTC confirmation procedure. Refer to [SRC-112, "DTC Logic"](#).

Is DTC detected?

YES >> GO TO 1.  
NO >> INSPECTION END

A  
B  
C  
D  
E  
F  
G  
I  
J  
K  
L  
M  
N  
O  
P

SRC

# B1137 SIDE AIR BAG MODULE LH

< DTC/CIRCUIT DIAGNOSIS >

## B1137 SIDE AIR BAG MODULE LH

### Description

INFOID:000000005174306

In case of frontal collision where acceleration is more than the specified level, the ignition materials are ignited by electric ignition system. The system burns the gas generating materials resulting in a chemical reaction. This generates hot gases that flow into the air bag through a filter and expand the bag.

### DTC Logic

INFOID:000000005174307

### DTC DETECTION LOGIC

DTC	Display contents of CONSULT-III	DTC detecting condition	Possible cause
B1137	SIDE MODULE LH [SHORT]	Side air bag module LH circuits are shorted to each other	<ul style="list-style-type: none"><li>• Disconnection of wiring harness and short</li><li>• Malfunction in side air bag module LH</li><li>• Malfunction in air bag diagnosis sensor unit</li></ul>

### DTC CONFIRMATION PROCEDURE

#### 1. CHECK SELF-DIAG RESULT

With CONSULT-III

1. Turn ignition switch ON.
2. Perform "AIR BAG" Self Diagnostic Result.

Without CONSULT-III

1. Turn ignition switch ON.
2. Check the air bag warning lamp status. Refer to [SRC-15. "Diagnosis with Air Bag Warning Lamp"](#).

#### NOTE:

SRS does not enter the diagnosis mode if no malfunction is detected in the user mode.

Is malfunctioning part detected?

- YES >> Refer to [SRC-114. "Diagnosis Procedure"](#).  
NO >> INSPECTION END

### Diagnosis Procedure

INFOID:000000005174308

#### WARNING:

- Before servicing, turn ignition switch OFF, disconnect battery negative terminal, and wait at least 3 minutes or more. (To discharge backup capacitor.)
- Never use unspecified tester or other measuring device.

#### 1. CHECK HARNESS CONNECTOR

Check the harness connector.

Is the inspection result normal?

- YES >> GO TO 2.  
NO >> Replace harness connector.

#### 2. CHECK WIRING HARNESS

Check the wiring harness externals.

Is the inspection result normal?

- YES >> GO TO 3.  
NO >> Replace wiring harness.

#### 3. REPLACE AIR BAG DIAGNOSIS SENSOR UNIT

1. Replace air bag diagnosis sensor unit. Refer to [SR-25. "Exploded View"](#).
2. Perform DTC confirmation procedure. Refer to [SRC-114. "DTC Logic"](#).

Is DTC detected?

- YES >> GO TO 4.  
NO >> INSPECTION END

## B1137 SIDE AIR BAG MODULE LH

< DTC/CIRCUIT DIAGNOSIS >

---

### 4. REPLACE SIDE AIR BAG MODULE

---

1. Replace side air bag module LH. Refer to [SE-129, "Exploded View"](#).
2. Perform DTC confirmation procedure. Refer to [SRC-114, "DTC Logic"](#).

Is DTC detected?

YES >> GO TO 1.  
NO >> INSPECTION END

A  
B  
C  
D  
E  
F  
G  
I  
J  
K  
L  
M  
N  
O  
P

SRC

# B1138, B1139, B1140, B1141, B1142, B1143 DIAGNOSIS SENSOR UNIT

< DTC/CIRCUIT DIAGNOSIS >

## B1138, B1139, B1140, B1141, B1142, B1143 DIAGNOSIS SENSOR UNIT

### Description

INFOID:000000005174309

- It detects a shock that is more than the specified level and monitors whether the driver and passenger air bags, side air bag, curtain air bag, and pre-tensioner seat belts operate normally.
- It contains the "G" sensors for both frontal and side collisions and spare battery function in case of main battery damage in collision.

### DTC Logic

INFOID:000000005174310

### DTC DETECTION LOGIC

DTC	Display contents of CONSULT-III	DTC detecting condition	Possible cause
B1138 B1139 B1140 B1141 B1142 B1143	CONTROL UNIT	Air bag diagnosis sensor unit is malfunctioning	Malfunction in air bag diagnosis sensor unit

### DTC CONFIRMATION PROCEDURE

#### 1. CHECK SELF-DIAG RESULT

With CONSULT-III

1. Turn ignition switch ON.
2. Perform "AIR BAG" Self Diagnostic Result.

Without CONSULT-III

1. Turn ignition switch ON.
2. Check the air bag warning lamp status. Refer to [SRC-15, "Diagnosis with Air Bag Warning Lamp"](#).

#### NOTE:

SRS does not enter the diagnosis mode if no malfunction is detected in the user mode.

Is malfunctioning part detected?

YES >> Refer to [SRC-116, "Diagnosis Procedure"](#).

NO >> INSPECTION END

### Diagnosis Procedure

INFOID:000000005174311

#### WARNING:

- Before servicing, turn ignition switch OFF, disconnect battery negative terminal, and wait at least 3 minutes or more. (To discharge backup capacitor.)
- Never use unspecified tester or other measuring device.

#### 1. CHECK HARNESS CONNECTOR

Check the harness connector.

Is the inspection result normal?

YES >> GO TO 2.

NO >> Replace harness connectors.

#### 2. CHECK WIRING HARNESS

Check the wiring harness externals.

Is the inspection result normal?

YES >> GO TO 3.

NO >> Replace wiring harness.

#### 3. REPLACE AIR BAG DIAGNOSIS SENSOR UNIT

1. Replace air bag diagnosis sensor unit. Refer to [SR-25, "Exploded View"](#).
2. Perform DTC confirmation procedure. Refer to [SRC-116, "DTC Logic"](#).

# B1138, B1139, B1140, B1141, B1142, B1143 DIAGNOSIS SENSOR UNIT

< DTC/CIRCUIT DIAGNOSIS >

---

Is DTC detected?

YES >> GO TO 1.

NO >> INSPECTION END

A

B

C

D

E

F

G

**SRC**

I

J

K

L

M

N

O

P

# B1144 DIAGNOSIS SENSOR UNIT

< DTC/CIRCUIT DIAGNOSIS >

## B1144 DIAGNOSIS SENSOR UNIT

### Description

INFOID:000000005174312

- It detects a shock that is more than the specified level and monitors whether the driver and passenger air bags, side air bag, curtain air bag, and pre-tensioner seat belts operate normally.
- It contains the "G" sensors for both frontal and side collisions and spare battery function in case of main battery damage in collision.

### DTC Logic

INFOID:000000005174313

### DTC DETECTION LOGIC

DTC	Display contents of CONSULT-III	DTC detecting condition	Possible cause
B1144	Diagnosis sensor unit	Air bag diagnosis sensor unit is malfunctioning or out of the specification	<ul style="list-style-type: none"><li>• Malfunction in air bag diagnosis sensor unit</li><li>• Configuration in air bag diagnosis sensor unit does not match the vehicles specification</li></ul>

### DTC CONFIRMATION PROCEDURE

#### 1. CHECK SELF-DIAG RESULT

With CONSULT-III

1. Turn ignition switch ON.
2. Perform "AIR BAG" Self Diagnostic Result.

Without CONSULT-III

1. Turn ignition switch ON.
2. Check the air bag warning lamp status. Refer to [SRC-15. "Diagnosis with Air Bag Warning Lamp"](#).

#### NOTE:

SRS does not enter the diagnosis mode if no malfunction is detected in the user mode.

Is malfunctioning part detected?

- YES >> Refer to [SRC-118. "Diagnosis Procedure"](#).  
NO >> INSPECTION END

### Diagnosis Procedure

INFOID:000000005174314

#### WARNING:

- **Before servicing, turn ignition switch OFF, disconnect battery negative terminal, and wait at least 3 minutes or more. (To discharge backup capacitor.)**
- **Never use unspecified tester or other measuring device.**

#### 1. CHECK HARNESS CONNECTOR

Check the harness connector.

Is the inspection result normal?

- YES >> GO TO 2.  
NO >> Replace harness connectors.

#### 2. CHECK WIRING HARNESS

Check the wiring harness externals.

Is the inspection result normal?

- YES >> GO TO 3.  
NO >> Replace wiring harness.

#### 3. REPLACE AIR BAG DIAGNOSIS SENSOR UNIT

1. Replace air bag diagnosis sensor unit. Refer to [SR-25. "Exploded View"](#).
2. Perform DTC confirmation procedure. Refer to [SRC-118. "DTC Logic"](#).

Is DTC detected?

- YES >> GO TO 1.  
NO >> INSPECTION END

# B1145 CURTAIN AIR BAG MODULE RH

< DTC/CIRCUIT DIAGNOSIS >

## B1145 CURTAIN AIR BAG MODULE RH

### Description

INFOID:000000005174315

In case of frontal collision where acceleration is more than the specified level, the ignition materials are ignited by electric ignition system. The system burns the gas generating materials resulting in a chemical reaction. This generates hot gases that flow into the air bag through a filter and expand the bag.

### DTC Logic

INFOID:000000005174316

### DTC DETECTION LOGIC

DTC	Display contents of CONSULT-III	DTC detecting condition	Possible cause
B1145	CURTAIN MODULE RH [OPEN]	Curtain air bag module RH circuit is open	<ul style="list-style-type: none"><li>• Disconnection of wiring harness and open</li><li>• Malfunction in side curtain air bag module RH</li><li>• Malfunction in air bag diagnosis sensor unit</li></ul>

### DTC CONFIRMATION PROCEDURE

#### 1. CHECK SELF-DIAG RESULT

With CONSULT-III

1. Turn ignition switch ON.
2. Perform "AIR BAG" Self Diagnostic Result.

Without CONSULT-III

1. Turn ignition switch ON.
2. Check the air bag warning lamp status. Refer to [SRC-15. "Diagnosis with Air Bag Warning Lamp"](#).

#### NOTE:

SRS does not enter the diagnosis mode if no malfunction is detected in the user mode.

Is malfunctioning part detected?

- YES >> Refer to [SRC-119. "Diagnosis Procedure"](#).  
NO >> INSPECTION END

### Diagnosis Procedure

INFOID:000000005174317

#### WARNING:

- Before servicing, turn ignition switch OFF, disconnect battery negative terminal, and wait at least 3 minutes or more. (To discharge backup capacitor.)
- Never use unspecified tester or other measuring device.

#### 1. CHECK HARNESS CONNECTOR

Check the harness connector.

Is the inspection result normal?

- YES >> GO TO 2.  
NO >> Replace harness connector.

#### 2. CHECK WIRING HARNESS

Check the wiring harness externals.

Is the inspection result normal?

- YES >> GO TO 3.  
NO >> Replace wiring harness.

#### 3. REPLACE AIR BAG DIAGNOSIS SENSOR UNIT

1. Replace air bag diagnosis sensor unit. Refer to [SR-25. "Exploded View"](#).
2. Perform DTC confirmation procedure. Refer to [SRC-119. "DTC Logic"](#).

Is DTC detected?

- YES >> GO TO 4.  
NO >> INSPECTION END

## B1145 CURTAIN AIR BAG MODULE RH

< DTC/CIRCUIT DIAGNOSIS >

---

### 4. REPLACE CURTAIN AIR BAG MODULE

---

1. Replace curtain air bag module RH. Refer to [SR-19, "Exploded View"](#)
2. Perform DTC confirmation procedure. Refer to [SRC-119, "DTC Logic"](#).

Is DTC detected?

- YES >> GO TO 1.  
NO >> INSPECTION END



# B1146 CURTAIN AIR BAG MODULE RH

< DTC/CIRCUIT DIAGNOSIS >

## B1146 CURTAIN AIR BAG MODULE RH

### Description

INFOID:000000005174318

In case of frontal collision where acceleration is more than the specified level, the ignition materials are ignited by electric ignition system. The system burns the gas generating materials resulting in a chemical reaction. This generates hot gases that flow into the air bag through a filter and expand the bag.

### DTC Logic

INFOID:000000005174319

### DTC DETECTION LOGIC

DTC	Display contents of CONSULT-III	DTC detecting condition	Possible cause
B1146	CURTAIN MODULE RH [VB-SHORT]	Curtain air bag module RH circuit is shorted to power supply circuit	<ul style="list-style-type: none"><li>• Disconnection of wiring harness and short</li><li>• Malfunction in curtain air bag module RH</li><li>• Malfunction in air bag diagnosis sensor unit</li></ul>

### DTC CONFIRMATION PROCEDURE

#### 1. CHECK SELF-DIAG RESULT

With CONSULT-III

1. Turn ignition switch ON.
2. Perform "AIR BAG" Self Diagnostic Result.

Without CONSULT-III

1. Turn ignition switch ON.
2. Check the air bag warning lamp status. Refer to [SRC-15, "Diagnosis with Air Bag Warning Lamp"](#).

#### NOTE:

SRS does not enter the diagnosis mode if no malfunction is detected in the user mode.

Is malfunctioning part detected?

- YES >> Refer to [SRC-121, "Diagnosis Procedure"](#).  
NO >> INSPECTION END

### Diagnosis Procedure

INFOID:000000005174320

#### WARNING:

- Before servicing, turn ignition switch OFF, disconnect battery negative terminal, and wait at least 3 minutes or more. (To discharge backup capacitor.)
- Never use unspecified tester or other measuring device.

#### 1. CHECK HARNESS CONNECTOR

Check the harness connector.

Is the inspection result normal?

- YES >> GO TO 2.  
NO >> Replace harness connector.

#### 2. CHECK WIRING HARNESS

Check the wiring harness externals.

Is the inspection result normal?

- YES >> GO TO 3.  
NO >> Replace wiring harness.

#### 3. REPLACE AIR BAG DIAGNOSIS SENSOR UNIT

1. Replace air bag diagnosis sensor unit. Refer to [SR-25, "Exploded View"](#).
2. Perform DTC confirmation procedure. Refer to [SRC-121, "DTC Logic"](#).

Is DTC detected?

- YES >> GO TO 4.  
NO >> INSPECTION END

## B1146 CURTAIN AIR BAG MODULE RH

< DTC/CIRCUIT DIAGNOSIS >

---

### 4. REPLACE CURTAIN AIR BAG MODULE

---

1. Replace curtain air bag module RH. Refer to [SR-19, "Exploded View"](#)
2. Perform DTC confirmation procedure. Refer to [SRC-121, "DTC Logic"](#).

Is DTC detected?

- YES >> GO TO 1.  
NO >> INSPECTION END

# B1147 CURTAIN AIR BAG MODULE RH

< DTC/CIRCUIT DIAGNOSIS >

## B1147 CURTAIN AIR BAG MODULE RH

### Description

INFOID:000000005174321

In case of frontal collision where acceleration is more than the specified level, the ignition materials are ignited by electric ignition system. The system burns the gas generating materials resulting in a chemical reaction. This generates hot gases that flow into the air bag through a filter and expand the bag.

### DTC Logic

INFOID:000000005174322

### DTC DETECTION LOGIC

DTC	Display contents of CONSULT-III	DTC detecting condition	Possible cause
B1147	CURTAIN MODULE RH [GND-SHORT]	Curtain air bag module RH circuit is shorted to ground	<ul style="list-style-type: none"><li>• Disconnection of wiring harness and short</li><li>• Malfunction in curtain air bag module RH</li><li>• Malfunction in air bag diagnosis sensor unit</li></ul>

### DTC CONFIRMATION PROCEDURE

#### 1. CHECK SELF-DIAG RESULT

With CONSULT-III

1. Turn ignition switch ON.
2. Perform "AIR BAG" Self Diagnostic Result.

Without CONSULT-III

1. Turn ignition switch ON.
2. Check the air bag warning lamp status. Refer to [SRC-15, "Diagnosis with Air Bag Warning Lamp"](#).

#### NOTE:

SRS does not enter the diagnosis mode if no malfunction is detected in the user mode.

Is malfunctioning part detected?

- YES >> Refer to [SRC-123, "Diagnosis Procedure"](#).  
NO >> INSPECTION END

### Diagnosis Procedure

INFOID:000000005174323

#### WARNING:

- Before servicing, turn ignition switch OFF, disconnect battery negative terminal, and wait at least 3 minutes or more. (To discharge backup capacitor.)
- Never use unspecified tester or other measuring device.

#### 1. CHECK HARNESS CONNECTOR

Check the harness connector.

Is the inspection result normal?

- YES >> GO TO 2.  
NO >> Replace harness connector.

#### 2. CHECK WIRING HARNESS

Check the wiring harness externals.

Is the inspection result normal?

- YES >> GO TO 3.  
NO >> Replace wiring harness.

#### 3. REPLACE AIR BAG DIAGNOSIS SENSOR UNIT

1. Replace air bag diagnosis sensor unit. Refer to [SR-25, "Exploded View"](#).
2. Perform DTC confirmation procedure. Refer to [SRC-123, "DTC Logic"](#).

Is DTC detected?

- YES >> GO TO 4.  
NO >> INSPECTION END

## B1147 CURTAIN AIR BAG MODULE RH

< DTC/CIRCUIT DIAGNOSIS >

---

### 4. REPLACE CURTAIN AIR BAG MODULE

---

1. Replace curtain air bag module RH. Refer to [SR-19, "Exploded View"](#)
2. Perform DTC confirmation procedure. Refer to [SRC-123, "DTC Logic"](#).

Is DTC detected?

- YES >> GO TO 1.  
NO >> INSPECTION END

# B1148 CURTAIN AIR BAG MODULE RH

< DTC/CIRCUIT DIAGNOSIS >

## B1148 CURTAIN AIR BAG MODULE RH

### Description

INFOID:000000005174324

In case of frontal collision where acceleration is more than the specified level, the ignition materials are ignited by electric ignition system. The system burns the gas generating materials resulting in a chemical reaction. This generates hot gases that flow into the air bag through a filter and expand the bag.

### DTC Logic

INFOID:000000005174325

### DTC DETECTION LOGIC

DTC	Display contents of CONSULT-III	DTC detecting condition	Possible cause
B1148	CURTAIN MODULE RH [SHORT]	Curtain air bag module RH circuits are shorted to each other	<ul style="list-style-type: none"><li>Disconnection of wiring harness and short</li><li>Malfunction in curtain air bag module RH</li><li>Malfunction in air bag diagnosis sensor unit</li></ul>

### DTC CONFIRMATION PROCEDURE

#### 1. CHECK SELF-DIAG RESULT

With CONSULT-III

- Turn ignition switch ON.
- Perform "AIR BAG" Self Diagnostic Result.

Without CONSULT-III

- Turn ignition switch ON.
- Check the air bag warning lamp status. Refer to [SRC-15, "Diagnosis with Air Bag Warning Lamp"](#).

#### NOTE:

SRS does not enter the diagnosis mode if no malfunction is detected in the user mode.

Is malfunctioning part detected?

- YES >> Refer to [SRC-125, "Diagnosis Procedure"](#).  
NO >> INSPECTION END

### Diagnosis Procedure

INFOID:000000005174326

#### WARNING:

- Before servicing, turn ignition switch OFF, disconnect battery negative terminal, and wait at least 3 minutes or more. (To discharge backup capacitor.)
- Never use unspecified tester or other measuring device.

#### 1. CHECK HARNESS CONNECTOR

Check the harness connector.

Is the inspection result normal?

- YES >> GO TO 2.  
NO >> Replace harness connector.

#### 2. CHECK WIRING HARNESS

Check the wiring harness externals.

Is the inspection result normal?

- YES >> GO TO 3.  
NO >> Replace wiring harness.

#### 3. REPLACE AIR BAG DIAGNOSIS SENSOR UNIT

- Replace air bag diagnosis sensor unit. Refer to [SR-25, "Exploded View"](#).
- Perform DTC confirmation procedure. Refer to [SRC-125, "DTC Logic"](#).

Is DTC detected?

- YES >> GO TO 4.  
NO >> INSPECTION END

## B1148 CURTAIN AIR BAG MODULE RH

< DTC/CIRCUIT DIAGNOSIS >

---

### 4. REPLACE CURTAIN AIR BAG MODULE

---

1. Replace curtain air bag module RH. Refer to [SR-19, "Exploded View"](#)
2. Perform DTC confirmation procedure. Refer to [SRC-125, "DTC Logic"](#).

Is DTC detected?

- YES >> GO TO 1.  
NO >> INSPECTION END

# B1150 CURTAIN AIR BAG MODULE LH

< DTC/CIRCUIT DIAGNOSIS >

## B1150 CURTAIN AIR BAG MODULE LH

### Description

INFOID:000000005174327

In case of frontal collision where acceleration is more than the specified level, the ignition materials are ignited by electric ignition system. The system burns the gas generating materials resulting in a chemical reaction. This generates hot gases that flow into the air bag through a filter and expand the bag.

### DTC Logic

INFOID:000000005174328

### DTC DETECTION LOGIC

DTC	Display contents of CONSULT-III	DTC detecting condition	Possible cause
B1150	CURTAIN MODULE LH [OPEN]	Curtain air bag module LH circuit is open	<ul style="list-style-type: none"><li>• Disconnection of wiring harness and open</li><li>• Malfunction in curtain air bag module LH</li><li>• Malfunction in air bag diagnosis sensor unit</li></ul>

### DTC CONFIRMATION PROCEDURE

#### 1. CHECK SELF-DIAG RESULT

With CONSULT-III

1. Turn ignition switch ON.
2. Perform "AIR BAG" Self Diagnostic Result.

Without CONSULT-III

1. Turn ignition switch ON.
2. Check the air bag warning lamp status. Refer to [SRC-15. "Diagnosis with Air Bag Warning Lamp"](#).

#### NOTE:

SRS does not enter the diagnosis mode if no malfunction is detected in the user mode.

Is malfunctioning part detected?

- YES >> Refer to [SRC-127. "Diagnosis Procedure"](#).  
NO >> INSPECTION END

### Diagnosis Procedure

INFOID:000000005174329

#### WARNING:

- Before servicing, turn ignition switch OFF, disconnect battery negative terminal, and wait at least 3 minutes or more. (To discharge backup capacitor.)
- Never use unspecified tester or other measuring device.

#### 1. CHECK HARNESS CONNECTOR

Check the harness connector.

Is the inspection result normal?

- YES >> GO TO 2.  
NO >> Replace harness connector.

#### 2. CHECK WIRING HARNESS

Check the wiring harness externals.

Is the inspection result normal?

- YES >> GO TO 3.  
NO >> Replace wiring harness.

#### 3. REPLACE AIR BAG DIAGNOSIS SENSOR UNIT

1. Replace air bag diagnosis sensor unit. Refer to [SR-25. "Exploded View"](#).
2. Perform DTC confirmation procedure. Refer to [SRC-127. "DTC Logic"](#).

Is DTC detected?

- YES >> GO TO 4.  
NO >> INSPECTION END

## B1150 CURTAIN AIR BAG MODULE LH

< DTC/CIRCUIT DIAGNOSIS >

---

### 4. REPLACE CURTAIN AIR BAG MODULE

---

1. Replace curtain air bag module LH. Refer to [SR-19, "Exploded View"](#)
2. Perform DTC confirmation procedure. Refer to [SRC-127, "DTC Logic"](#).

Is DTC detected?

- YES >> GO TO 1.  
NO >> INSPECTION END



# B1151 CURTAIN AIR BAG MODULE LH

< DTC/CIRCUIT DIAGNOSIS >

## B1151 CURTAIN AIR BAG MODULE LH

### Description

INFOID:000000005174330

In case of frontal collision where acceleration is more than the specified level, the ignition materials are ignited by electric ignition system. The system burns the gas generating materials resulting in a chemical reaction. This generates hot gases that flow into the air bag through a filter and expand the bag.

### DTC Logic

INFOID:000000005174331

### DTC DETECTION LOGIC

DTC	Display contents of CONSULT-III	DTC detecting condition	Possible cause
B1151	CURTAIN MODULE LH [VB-SHORT]	Curtain air bag module LH circuit is shorted to power supply circuit	<ul style="list-style-type: none"><li>• Disconnection of wiring harness and short</li><li>• Malfunction in curtain air bag module LH</li><li>• Malfunction in air bag diagnosis sensor unit</li></ul>

### DTC CONFIRMATION PROCEDURE

#### 1. CHECK SELF-DIAG RESULT

With CONSULT-III

1. Turn ignition switch ON.
2. Perform "AIR BAG" Self Diagnostic Result.

Without CONSULT-III

1. Turn ignition switch ON.
2. Check the air bag warning lamp status. Refer to [SRC-15, "Diagnosis with Air Bag Warning Lamp"](#).

#### NOTE:

SRS does not enter the diagnosis mode if no malfunction is detected in the user mode.

Is malfunctioning part detected?

- YES >> Refer to [SRC-129, "Diagnosis Procedure"](#).  
NO >> INSPECTION END

### Diagnosis Procedure

INFOID:000000005174332

#### WARNING:

- Before servicing, turn ignition switch OFF, disconnect battery negative terminal, and wait at least 3 minutes or more. (To discharge backup capacitor.)
- Never use unspecified tester or other measuring device.

#### 1. CHECK HARNESS CONNECTOR

Check the harness connector.

Is the inspection result normal?

- YES >> GO TO 2.  
NO >> Replace harness connector.

#### 2. CHECK WIRING HARNESS

Check the wiring harness externals.

Is the inspection result normal?

- YES >> GO TO 3.  
NO >> Replace wiring harness.

#### 3. REPLACE AIR BAG DIAGNOSIS SENSOR UNIT

1. Replace air bag diagnosis sensor unit. Refer to [SR-25, "Exploded View"](#).
2. Perform DTC confirmation procedure. Refer to [SRC-129, "DTC Logic"](#).

Is DTC detected?

- YES >> GO TO 4.  
NO >> INSPECTION END

## B1151 CURTAIN AIR BAG MODULE LH

< DTC/CIRCUIT DIAGNOSIS >

---

### 4. REPLACE CURTAIN AIR BAG MODULE

---

1. Replace curtain air bag module LH. Refer to [SR-19, "Exploded View"](#)
2. Perform DTC confirmation procedure. Refer to [SRC-129, "DTC Logic"](#).

Is DTC detected?

- YES >> GO TO 1.  
NO >> INSPECTION END

# B1152 CURTAIN AIR BAG MODULE LH

< DTC/CIRCUIT DIAGNOSIS >

## B1152 CURTAIN AIR BAG MODULE LH

### Description

INFOID:000000005174333

In case of frontal collision where acceleration is more than the specified level, the ignition materials are ignited by electric ignition system. The system burns the gas generating materials resulting in a chemical reaction. This generates hot gases that flow into the air bag through a filter and expand the bag.

### DTC Logic

INFOID:000000005174334

### DTC DETECTION LOGIC

DTC	Display contents of CONSULT-III	DTC detecting condition	Possible cause
B1152	CURTAIN MODULE LH [GND-SHORT]	Curtain air bag module LH circuit is shorted to ground	<ul style="list-style-type: none"><li>• Disconnection of wiring harness and short</li><li>• Malfunction in curtain air bag module LH</li><li>• Malfunction in air bag diagnosis sensor unit</li></ul>

### DTC CONFIRMATION PROCEDURE

#### 1. CHECK SELF-DIAG RESULT

With CONSULT-III

1. Turn ignition switch ON.
2. Perform "AIR BAG" Self Diagnostic Result.

Without CONSULT-III

1. Turn ignition switch ON.
2. Check the air bag warning lamp status. Refer to [SRC-15, "Diagnosis with Air Bag Warning Lamp"](#).

#### NOTE:

SRS does not enter the diagnosis mode if no malfunction is detected in the user mode.

Is malfunctioning part detected?

- YES >> Refer to [SRC-131, "Diagnosis Procedure"](#).  
NO >> INSPECTION END

### Diagnosis Procedure

INFOID:000000005174335

#### WARNING:

- Before servicing, turn ignition switch OFF, disconnect battery negative terminal, and wait at least 3 minutes or more. (To discharge backup capacitor.)
- Never use unspecified tester or other measuring device.

#### 1. CHECK HARNESS CONNECTOR

Check the harness connector.

Is the inspection result normal?

- YES >> GO TO 2.  
NO >> Replace harness connector.

#### 2. CHECK WIRING HARNESS

Check the wiring harness externals.

Is the inspection result normal?

- YES >> GO TO 3.  
NO >> Replace wiring harness.

#### 3. REPLACE AIR BAG DIAGNOSIS SENSOR UNIT

1. Replace air bag diagnosis sensor unit. Refer to [SR-25, "Exploded View"](#).
2. Perform DTC confirmation procedure. Refer to [SRC-131, "DTC Logic"](#).

Is DTC detected?

- YES >> GO TO 4.  
NO >> INSPECTION END

## B1152 CURTAIN AIR BAG MODULE LH

< DTC/CIRCUIT DIAGNOSIS >

---

### 4. REPLACE CURTAIN AIR BAG MODULE

---

1. Replace curtain air bag module LH. Refer to [SR-19, "Exploded View"](#)
2. Perform DTC confirmation procedure. Refer to [SRC-131, "DTC Logic"](#).

Is DTC detected?

- YES >> GO TO 1.  
NO >> INSPECTION END

# B1153 CURTAIN AIR BAG MODULE LH

< DTC/CIRCUIT DIAGNOSIS >

## B1153 CURTAIN AIR BAG MODULE LH

### Description

INFOID:000000005174336

In case of frontal collision where acceleration is more than the specified level, the ignition materials are ignited by electric ignition system. The system burns the gas generating materials resulting in a chemical reaction. This generates hot gases that flow into the air bag through a filter and expand the bag.

### DTC Logic

INFOID:000000005174337

### DTC DETECTION LOGIC

DTC	Display contents of CONSULT-III	DTC detecting condition	Possible cause
B1153	CURTAIN MODULE LH [SHORT]	Curtain air bag module LH circuits are shorted to each other	<ul style="list-style-type: none"><li>Disconnection of wiring harness and short</li><li>Malfunction in curtain air bag module LH</li><li>Malfunction in air bag diagnosis sensor unit</li></ul>

### DTC CONFIRMATION PROCEDURE

#### 1. CHECK SELF-DIAG RESULT

With CONSULT-III

- Turn ignition switch ON.
- Perform "AIR BAG" Self Diagnostic Result.

Without CONSULT-III

- Turn ignition switch ON.
- Check the air bag warning lamp status. Refer to [SRC-15, "Diagnosis with Air Bag Warning Lamp"](#).

#### NOTE:

SRS does not enter the diagnosis mode if no malfunction is detected in the user mode.

Is malfunctioning part detected?

- YES >> Refer to [SRC-133, "Diagnosis Procedure"](#).  
NO >> INSPECTION END

### Diagnosis Procedure

INFOID:000000005174338

#### WARNING:

- Before servicing, turn ignition switch OFF, disconnect battery negative terminal, and wait at least 3 minutes or more. (To discharge backup capacitor.)
- Never use unspecified tester or other measuring device.

#### 1. CHECK HARNESS CONNECTOR

Check the harness connector.

Is the inspection result normal?

- YES >> GO TO 2.  
NO >> Replace harness connector.

#### 2. CHECK WIRING HARNESS

Check the wiring harness externals.

Is the inspection result normal?

- YES >> GO TO 3.  
NO >> Replace wiring harness.

#### 3. REPLACE AIR BAG DIAGNOSIS SENSOR UNIT

- Replace air bag diagnosis sensor unit. Refer to [SR-25, "Exploded View"](#).
- Perform DTC confirmation procedure. Refer to [SRC-133, "DTC Logic"](#).

Is DTC detected?

- YES >> GO TO 4.  
NO >> INSPECTION END

## B1153 CURTAIN AIR BAG MODULE LH

< DTC/CIRCUIT DIAGNOSIS >

---

### 4. REPLACE CURTAIN AIR BAG MODULE

---

1. Replace curtain air bag module LH. Refer to [SR-19, "Exploded View"](#)
2. Perform DTC confirmation procedure. Refer to [SRC-133, "DTC Logic"](#).

Is DTC detected?

- YES >> GO TO 1.  
NO >> INSPECTION END

# B1154, B1155, B1156, B1157, B1158, B1159 DIAGNOSIS SENSOR UNIT

< DTC/CIRCUIT DIAGNOSIS >

## B1154, B1155, B1156, B1157, B1158, B1159 DIAGNOSIS SENSOR UNIT

### Description

INFOID:000000005174339

- It detects a shock that is more than the specified level and monitors whether the driver and passenger air bags, side air bag, curtain air bag, and pre-tensioner seat belts operate normally.
- It contains the "G" sensors for both frontal and side collisions and spare battery function in case of main battery damage in collision.

### DTC Logic

INFOID:000000005174340

### DTC DETECTION LOGIC

DTC	Display contents of CONSULT-III	DTC detecting condition	Possible cause
B1154 B1155 B1156 B1157 B1158 B1159	CONTROL UNIT	Air bag diagnosis sensor unit is malfunctioning	Malfunction in air bag diagnosis sensor unit

### DTC CONFIRMATION PROCEDURE

#### 1. CHECK SELF-DIAG RESULT

With CONSULT-III

1. Turn ignition switch ON.
2. Perform "AIR BAG" Self Diagnostic Result.

Without CONSULT-III

1. Turn ignition switch ON.
2. Check the air bag warning lamp status. Refer to [SRC-15, "Diagnosis with Air Bag Warning Lamp"](#).

#### NOTE:

SRS does not enter the diagnosis mode if no malfunction is detected in the user mode.

Is malfunctioning part detected?

- YES >> Refer to [SRC-135, "Diagnosis Procedure"](#).  
NO >> INSPECTION END

### Diagnosis Procedure

INFOID:000000005174341

#### WARNING:

- Before servicing, turn ignition switch OFF, disconnect battery negative terminal, and wait at least 3 minutes or more. (To discharge backup capacitor.)
- Never use unspecified tester or other measuring device.

#### 1. CHECK HARNESS CONNECTOR

Check the harness connector.

Is the inspection result normal?

- YES >> GO TO 2.  
NO >> Replace harness connectors.

#### 2. CHECK WIRING HARNESS

Check the wiring harness externals.

Is the inspection result normal?

- YES >> GO TO 3.  
NO >> Replace wiring harness.

#### 3. REPLACE AIR BAG DIAGNOSIS SENSOR UNIT

1. Replace air bag diagnosis sensor unit. Refer to [SR-25, "Exploded View"](#).
2. Perform DTC confirmation procedure. Refer to [SRC-135, "DTC Logic"](#).

# **B1154, B1155, B1156, B1157, B1158, B1159 DIAGNOSIS SENSOR UNIT**

< DTC/CIRCUIT DIAGNOSIS >

---

Is DTC detected?

YES >> GO TO 1.

NO >> INSPECTION END



# B1170, B1171, B1172, B1173, B1174, B1175 DIAGNOSIS SENSOR UNIT

< DTC/CIRCUIT DIAGNOSIS >

## B1170, B1171, B1172, B1173, B1174, B1175 DIAGNOSIS SENSOR UNIT

### Description

INFOID:000000005174342

- It detects a shock that is more than the specified level and monitors whether the driver and passenger air bags, side air bag, curtain air bag, and pre-tensioner seat belts operate normally.
- It contains the "G" sensors for both frontal and side collisions and spare battery function in case of main battery damage in collision.

### DTC Logic

INFOID:000000005174343

### DTC DETECTION LOGIC

DTC	Display contents of CONSULT-III	DTC detecting condition	Possible cause
B1170 B1171 B1172 B1173 B1174 B1175	CONTROL UNIT	Air bag diagnosis sensor unit is malfunctioning	Malfunction in air bag diagnosis sensor unit

### DTC CONFIRMATION PROCEDURE

#### 1. CHECK SELF-DIAG RESULT

With CONSULT-III

1. Turn ignition switch ON.
2. Perform "AIR BAG" Self Diagnostic Result.

Without CONSULT-III

1. Turn ignition switch ON.
2. Check the air bag warning lamp status. Refer to [SRC-15, "Diagnosis with Air Bag Warning Lamp"](#).

#### NOTE:

SRS does not enter the diagnosis mode if no malfunction is detected in the user mode.

Is malfunctioning part detected?

- YES >> Refer to [SRC-137, "Diagnosis Procedure"](#).  
NO >> INSPECTION END

### Diagnosis Procedure

INFOID:000000005174344

#### WARNING:

- Before servicing, turn ignition switch OFF, disconnect battery negative terminal, and wait at least 3 minutes or more. (To discharge backup capacitor.)
- Never use unspecified tester or other measuring device.

#### 1. CHECK HARNESS CONNECTOR

Check the harness connector.

Is the inspection result normal?

- YES >> GO TO 2.  
NO >> Replace harness connectors.

#### 2. CHECK WIRING HARNESS

Check the wiring harness externals.

Is the inspection result normal?

- YES >> GO TO 3.  
NO >> Replace wiring harness.

#### 3. REPLACE AIR BAG DIAGNOSIS SENSOR UNIT

1. Replace air bag diagnosis sensor unit. Refer to [SR-25, "Exploded View"](#).
2. Perform DTC confirmation procedure. Refer to [SRC-137, "DTC Logic"](#).

# B1170, B1171, B1172, B1173, B1174, B1175 DIAGNOSIS SENSOR UNIT

< DTC/CIRCUIT DIAGNOSIS >

---

Is DTC detected?

YES >> GO TO 1.

NO >> INSPECTION END

# B1186, B1187, B1188, B1189, B1190, B1191 DIAGNOSIS SENSOR UNIT

< DTC/CIRCUIT DIAGNOSIS >

## B1186, B1187, B1188, B1189, B1190, B1191 DIAGNOSIS SENSOR UNIT

### Description

INFOID:000000005174345

- It detects a shock that is more than the specified level and monitors whether the driver and passenger air bags, side air bag, curtain air bag, and pre-tensioner seat belts operate normally.
- It contains the "G" sensors for both frontal and side collisions and spare battery function in case of main battery damage in collision.

### DTC Logic

INFOID:000000005174346

### DTC DETECTION LOGIC

DTC	Display contents of CONSULT-III	DTC detecting condition	Possible cause
B1186 B1187 B1188 B1189 B1190 B1191	CONTROL UNIT	Air bag diagnosis sensor unit is malfunctioning	Malfunction in air bag diagnosis sensor unit

### DTC CONFIRMATION PROCEDURE

#### 1. CHECK SELF-DIAG RESULT

With CONSULT-III

1. Turn ignition switch ON.
2. Perform "AIR BAG" Self Diagnostic Result.

Without CONSULT-III

1. Turn ignition switch ON.
2. Check the air bag warning lamp status. Refer to [SRC-15, "Diagnosis with Air Bag Warning Lamp"](#).

#### NOTE:

SRS does not enter the diagnosis mode if no malfunction is detected in the user mode.

Is malfunctioning part detected?

- YES >> Refer to [SRC-139, "Diagnosis Procedure"](#).  
NO >> INSPECTION END

### Diagnosis Procedure

INFOID:000000005174347

#### WARNING:

- **Before servicing, turn ignition switch OFF, disconnect battery negative terminal, and wait at least 3 minutes or more. (To discharge backup capacitor.)**
- **Never use unspecified tester or other measuring device.**

#### 1. CHECK HARNESS CONNECTOR

Check the harness connector.

Is the inspection result normal?

- YES >> GO TO 2.  
NO >> Replace harness connectors.

#### 2. CHECK WIRING HARNESS

Check the wiring harness externals.

Is the inspection result normal?

- YES >> GO TO 3.  
NO >> Replace wiring harness.

#### 3. REPLACE AIR BAG DIAGNOSIS SENSOR UNIT

1. Replace air bag diagnosis sensor unit. Refer to [SR-25, "Exploded View"](#).
2. Perform DTC confirmation procedure. Refer to [SRC-139, "DTC Logic"](#).

## **B1186, B1187, B1188, B1189, B1190, B1191 DIAGNOSIS SENSOR UNIT**

< DTC/CIRCUIT DIAGNOSIS >

---

Is DTC detected?

YES >> GO TO 1.

NO >> INSPECTION END

# B1202, B1203, B1204, B1205, B1206, B1207 DIAGNOSIS SENSOR UNIT

< DTC/CIRCUIT DIAGNOSIS >

## B1202, B1203, B1204, B1205, B1206, B1207 DIAGNOSIS SENSOR UNIT

### Description

INFOID:000000005174348

- It detects a shock that is more than the specified level and monitors whether the driver and passenger air bags, side air bag, curtain air bag, and pre-tensioner seat belts operate normally.
- It contains the "G" sensors for both frontal and side collisions and spare battery function in case of main battery damage in collision.

### DTC Logic

INFOID:000000005174349

### DTC DETECTION LOGIC

DTC	Display contents of CONSULT-III	DTC detecting condition	Possible cause
B1202 B1203 B1204 B1205 B1206 B1207	CONTROL UNIT	Air bag diagnosis sensor unit is malfunctioning	Malfunction in air bag diagnosis sensor unit

### DTC CONFIRMATION PROCEDURE

#### 1. CHECK SELF-DIAG RESULT

With CONSULT-III

1. Turn ignition switch ON.
2. Perform "AIR BAG" Self Diagnostic Result.

Without CONSULT-III

1. Turn ignition switch ON.
2. Check the air bag warning lamp status. Refer to [SRC-15, "Diagnosis with Air Bag Warning Lamp"](#).

#### NOTE:

SRS does not enter the diagnosis mode if no malfunction is detected in the user mode.

Is malfunctioning part detected?

- YES >> Refer to [SRC-141, "Diagnosis Procedure"](#).  
NO >> INSPECTION END

### Diagnosis Procedure

INFOID:000000005174350

#### WARNING:

- Before servicing, turn ignition switch OFF, disconnect battery negative terminal, and wait at least 3 minutes or more. (To discharge backup capacitor.)
- Never use unspecified tester or other measuring device.

#### 1. CHECK HARNESS CONNECTOR

Check the harness connector.

Is the inspection result normal?

- YES >> GO TO 2.  
NO >> Replace harness connectors.

#### 2. CHECK WIRING HARNESS

Check the wiring harness externals.

Is the inspection result normal?

- YES >> GO TO 3.  
NO >> Replace wiring harness.

#### 3. REPLACE AIR BAG DIAGNOSIS SENSOR UNIT

1. Replace air bag diagnosis sensor unit. Refer to [SR-25, "Exploded View"](#).
2. Perform DTC confirmation procedure. Refer to [SRC-141, "DTC Logic"](#).

## **B1202, B1203, B1204, B1205, B1206, B1207 DIAGNOSIS SENSOR UNIT**

< DTC/CIRCUIT DIAGNOSIS >

---

Is DTC detected?

YES >> GO TO 1.

NO >> INSPECTION END

# B1209 FRONTAL COLLISION DETECTION

< DTC/CIRCUIT DIAGNOSIS >

## B1209 FRONTAL COLLISION DETECTION

### Description

INFOID:000000005174351

The air bags and seat belt pre-tensioners for driver and passenger are activated by the air bag diagnosis sensor unit signal transmitted at the time of the frontal collision.

### DTC Logic

INFOID:000000005174352

### DTC DETECTION LOGIC

DTC	Display contents of CONSULT-III	DTC detecting condition	Possible cause
B1209	FRONTAL COLLISION DETECTION	Seat belt pre-tensioner, driver side air bag and passenger air bag are deployed	—

### DTC CONFIRMATION PROCEDURE

#### 1. CHECK SELF-DIAG RESULT

With CONSULT-III

1. Turn ignition switch ON.
2. Perform "AIR BAG" Self Diagnostic Result.

Without CONSULT-III

1. Turn ignition switch ON.
2. Check the air bag warning lamp status. Refer to [SRC-15, "Diagnosis with Air Bag Warning Lamp"](#).

#### NOTE:

SRS does not enter the diagnosis mode if no malfunction is detected in the user mode.

Is malfunctioning part detected?

- YES >> Refer to [SRC-143, "Diagnosis Procedure"](#).  
NO >> INSPECTION END

### Diagnosis Procedure

INFOID:000000005511292

#### WARNING:

- Before servicing, turn ignition switch OFF, disconnect battery negative terminal, and wait at least 3 minutes or more. (To discharge backup capacitor.)
- Never use unspecified tester or other measuring device.

#### 1. PERFORM COLLISION DIAGNOSIS

Perform collision diagnosis. Refer to [SR-5, "FOR FRONTAL COLLISION : When SRS is activated in a collision"](#) or [SR-6, "FOR FRONTAL COLLISION : When SRS is not activated in a collision"](#).

Is collision diagnosis complete?

- YES >> GO TO 2.  
NO >> INSPECTION END

#### 2. FINAL INSPECTION

Perform "AIR BAG" Self Diagnostic Result.

Is the inspection result normal?

- YES >> INSPECTION END  
NO >> Perform diagnosis of applicable DTC. Refer to [SRC-152, "DTC Index"](#).

# B1210 SIDE COLLISION DETECTION

< DTC/CIRCUIT DIAGNOSIS >

## B1210 SIDE COLLISION DETECTION

### Description

INFOID:000000005174354

The side air bag and curtain air bag are activated by the air bag diagnosis sensor unit signal transmitted at the time of side collision.

### DTC Logic

INFOID:000000005174355

### DTC DETECTION LOGIC

DTC	Display contents of CONSULT-III	DTC detecting condition	Possible cause
B1210	SIDE COLLISION DETECTION	Side air bag and curtain air bag are deployed	—

### DTC CONFIRMATION PROCEDURE

#### 1. CHECK SELF-DIAG RESULT

With CONSULT-III

1. Turn ignition switch ON.
2. Perform "AIR BAG" Self Diagnostic Result.

Without CONSULT-III

1. Turn ignition switch ON.
2. Check the air bag warning lamp status. Refer to [SRC-15, "Diagnosis with Air Bag Warning Lamp"](#).

#### NOTE:

SRS does not enter the diagnosis mode if no malfunction is detected in the user mode.

Is malfunctioning part detected?

- YES >> Refer to [SRC-144, "Diagnosis Procedure"](#).  
NO >> INSPECTION END

### Diagnosis Procedure

INFOID:000000005511293

#### WARNING:

- Before servicing, turn ignition switch OFF, disconnect battery negative terminal, and wait at least 3 minutes or more. (To discharge backup capacitor.)
- Never use unspecified tester or other measuring device.

#### 1. PERFORM COLLISION DIAGNOSIS

Perform collision diagnosis. Refer to [SR-7, "FOR SIDE AND ROLLOVER COLLISION : When SRS is activated in a collision"](#) or [SR-8, "FOR SIDE AND ROLLOVER COLLISION : When SRS is not activated in a collision"](#).

Is collision diagnosis complete?

- YES >> GO TO 2.  
NO >> INSPECTION END

#### 2. FINAL INSPECTION

Perform "AIR BAG" Self Diagnostic Result.

Is the inspection result normal?

- YES >> INSPECTION END  
NO >> Perform diagnosis of applicable DTC. Refer to [SRC-152, "DTC Index"](#).



# B1211 ROLLOVER DETECTION

< DTC/CIRCUIT DIAGNOSIS >

## B1211 ROLLOVER DETECTION

### Description

INFOID:000000005174357

The seat belt pre-tensioner and curtain air bag are activated by the air bag diagnosis sensor unit signal at the time of rollover.

### DTC Logic

INFOID:000000005174358

### DTC DETECTION LOGIC

With CONSULT-III

DTC No. Index ("SELF-DIAG [CURRENT]"), ("SELF-DIAG [PAST]" or "TROUBLE DIAG RECORD")

DTC	Display contents of CONSULT-III	DTC detecting condition	Possible cause
B1211	ROLLOVER DETECTION	Seat belt pre-tensioner and curtain air bag module are deployed because of rollover detection	—

### DTC CONFIRMATION PROCEDURE

#### 1. CHECK SELF-DIAG RESULT

With CONSULT-III

1. Turn ignition switch ON.
2. Perform "AIR BAG" Self Diagnostic Result.

Without CONSULT-III

1. Turn ignition switch ON.
2. Check the air bag warning lamp status. Refer to [SRC-15, "Diagnosis with Air Bag Warning Lamp"](#).

#### NOTE:

SRS does not enter the diagnosis mode if no malfunction is detected in the user mode.

Is malfunctioning part detected?

- YES >> Refer to [SRC-145, "Diagnosis Procedure"](#).  
NO >> INSPECTION END

### Diagnosis Procedure

INFOID:000000005511294

#### WARNING:

- Before servicing, turn ignition switch OFF, disconnect battery negative terminal, and wait at least 3 minutes or more. (To discharge backup capacitor.)
- Never use unspecified tester or other measuring device.

#### 1. PERFORM COLLISION DIAGNOSIS

Perform collision diagnosis. Refer to [SR-7, "FOR SIDE AND ROLLOVER COLLISION : When SRS is activated in a collision"](#) or [SR-8, "FOR SIDE AND ROLLOVER COLLISION : When SRS is not activated in a collision"](#).

Is collision diagnosis complete?

- YES >> GO TO 2.  
NO >> INSPECTION END

#### 2. FINAL INSPECTION

Perform "AIR BAG" Self Diagnostic Result.

Is the inspection result normal?

- YES >> INSPECTION END  
NO >> Perform diagnosis of applicable DTC. Refer to [SRC-152, "DTC Index"](#).

# B1212, B1213, B1214 SATELLITE SENSOR RH

< DTC/CIRCUIT DIAGNOSIS >

## B1212, B1213, B1214 SATELLITE SENSOR RH

### Description

INFOID:000000005174360

Satellite sensor is a G sensor that outputs voltage signal during deceleration at the time of a vehicle side collision that is more than the specified limit is detected.

### DTC Logic

INFOID:000000005174361

### DTC DETECTION LOGIC

DTC	Display contents of CONSULT-III	DTC detecting condition	Possible cause
B1212 B1213 B1214	RH1 SAT-SENS	Satellite sensor RH is malfunctioning	<ul style="list-style-type: none"><li>• Disconnection of wiring harness</li><li>• Malfunction in satellite sensor RH</li><li>• Malfunction in air bag diagnosis sensor unit</li></ul>

### DTC CONFIRMATION PROCEDURE

#### 1. CHECK SELF-DIAG RESULT

With CONSULT-III

1. Turn ignition switch ON.
2. Perform "AIR BAG" Self Diagnostic Result.

Without CONSULT-III

1. Turn ignition switch ON.
2. Check the air bag warning lamp status. Refer to [SRC-15, "Diagnosis with Air Bag Warning Lamp"](#).

#### NOTE:

SRS does not enter the diagnosis mode if no malfunction is detected in the user mode.

Is malfunctioning part detected?

- YES >> Refer to [SRC-146, "Diagnosis Procedure"](#).  
NO >> INSPECTION END

### Diagnosis Procedure

INFOID:000000005174362

#### WARNING:

- Before servicing, turn ignition switch OFF, disconnect battery negative terminal, and wait at least 3 minutes or more. (To discharge backup capacitor.)
- Never use unspecified tester or other measuring device.

#### 1. CHECK HARNESS CONNECTOR

Check the harness connector.

Is the inspection result normal?

- YES >> GO TO 2.  
NO >> Replace harness connector.

#### 2. CHECK WIRING HARNESS

Check the wiring harness externals.

Is the inspection result normal?

- YES >> GO TO 3.  
NO >> Replace wiring harness.

#### 3. REPLACE AIR BAG DIAGNOSIS SENSOR UNIT

1. Replace air bag diagnosis sensor unit. Refer to [SR-25, "Exploded View"](#).
2. Perform DTC confirmation procedure. Refer to [SRC-146, "DTC Logic"](#).

Is DTC detected?

- YES >> GO TO 4.  
NO >> INSPECTION END

#### 4. REPLACE SATELLITE SENSOR

## B1212, B1213, B1214 SATELLITE SENSOR RH

### < DTC/CIRCUIT DIAGNOSIS >

---

1. Replace satellite sensor RH. Refer to [SR-23, "Exploded View"](#).
2. Perform DTC confirmation procedure. Refer to [SRC-146, "DTC Logic"](#).

#### Is DTC detected?

YES >> GO TO 1.

NO >> INSPECTION END

A

B

C

D

E

F

G

**SRC**

I

J

K

L

M

N

O

P

# B1215, B1216, B1217 SATELLITE SENSOR LH

< DTC/CIRCUIT DIAGNOSIS >

## B1215, B1216, B1217 SATELLITE SENSOR LH

### Description

INFOID:000000005174363

Satellite sensor is a G sensor that outputs voltage signal during deceleration at the time of a vehicle side collision that is more than the specified limit is detected.

### DTC Logic

INFOID:000000005174364

### DTC DETECTION LOGIC

DTC	Display contents of CONSULT-III	DTC detecting condition	Possible cause
B1215 B1216 B1217	LH1 SAT-SENS	Satellite sensor LH is malfunctioning	<ul style="list-style-type: none"><li>• Disconnection of wiring harness</li><li>• Malfunction in satellite sensor LH</li><li>• Malfunction in air bag diagnosis sensor unit</li></ul>

### DTC CONFIRMATION PROCEDURE

#### 1. CHECK SELF-DIAG RESULT

With CONSULT-III

1. Turn ignition switch ON.
2. Perform "AIR BAG" Self Diagnostic Result.

Without CONSULT-III

1. Turn ignition switch ON.
2. Check the air bag warning lamp status. Refer to [SRC-15, "Diagnosis with Air Bag Warning Lamp"](#).

#### NOTE:

SRS does not enter the diagnosis mode if no malfunction is detected in the user mode.

Is malfunctioning part detected?

- YES >> Refer to [SRC-148, "Diagnosis Procedure"](#).  
NO >> INSPECTION END

### Diagnosis Procedure

INFOID:000000005174365

#### WARNING:

- Before servicing, turn ignition switch OFF, disconnect battery negative terminal, and wait at least 3 minutes or more. (To discharge backup capacitor.)
- Never use unspecified tester or other measuring device.

#### 1. CHECK HARNESS CONNECTOR

Check the harness connector.

Is the inspection result normal?

- YES >> GO TO 2.  
NO >> Replace harness connector.

#### 2. CHECK WIRING HARNESS

Check the wiring harness externals.

Is the inspection result normal?

- YES >> GO TO 3.  
NO >> Replace wiring harness.

#### 3. REPLACE AIR BAG DIAGNOSIS SENSOR UNIT

1. Replace air bag diagnosis sensor unit. Refer to [SR-25, "Exploded View"](#).
2. Perform DTC confirmation procedure. Refer to [SRC-148, "DTC Logic"](#).

Is DTC detected?

- YES >> GO TO 4.  
NO >> INSPECTION END

#### 4. REPLACE SATELLITE SENSOR

## B1215, B1216, B1217 SATELLITE SENSOR LH

### < DTC/CIRCUIT DIAGNOSIS >

---

1. Replace satellite sensor LH. Refer to [SR-23, "Exploded View"](#).
2. Perform DTC confirmation procedure. Refer to [SRC-148, "DTC Logic"](#)

#### Is DTC detected?

YES >> GO TO 1.

NO >> INSPECTION END

A

B

C

D

E

F

G

**SRC**

I

J

K

L

M

N

O

P

# B1218, B1219, B1220, B1221, B1222, B1223 DIAGNOSIS SENSOR UNIT

< DTC/CIRCUIT DIAGNOSIS >

## B1218, B1219, B1220, B1221, B1222, B1223 DIAGNOSIS SENSOR UNIT

### Description

INFOID:000000005174366

- It detects a shock that is more than the specified level and monitors whether the driver and passenger air bags, side air bag, curtain air bag, and pre-tensioner seat belts operate normally.
- It contains the "G" sensors for both frontal and side collisions and spare battery function in case of main battery damage in collision.

### DTC Logic

INFOID:000000005174367

### DTC DETECTION LOGIC

DTC	Display contents of CONSULT-III	DTC detecting condition	Possible cause
B1218 B1219 B1220 B1221 B1222 B1223	CONTROL UNIT	Air bag diagnosis sensor unit is malfunctioning	Malfunction in air bag diagnosis sensor unit

### DTC CONFIRMATION PROCEDURE

#### 1. CHECK SELF-DIAG RESULT

With CONSULT-III

1. Turn ignition switch ON.
2. Perform "AIR BAG" Self Diagnostic Result.

Without CONSULT-III

1. Turn ignition switch ON.
2. Check the air bag warning lamp status. Refer to [SRC-15, "Diagnosis with Air Bag Warning Lamp"](#).

#### NOTE:

SRS does not enter the diagnosis mode if no malfunction is detected in the user mode.

Is malfunctioning part detected?

- YES >> Refer to [SRC-150, "Diagnosis Procedure"](#).  
NO >> INSPECTION END

### Diagnosis Procedure

INFOID:000000005174368

#### WARNING:

- Before servicing, turn ignition switch OFF, disconnect battery negative terminal, and wait at least 3 minutes or more. (To discharge backup capacitor.)
- Never use unspecified tester or other measuring device.

#### 1. CHECK HARNESS CONNECTOR

Check the harness connector.

Is the inspection result normal?

- YES >> GO TO 2.  
NO >> Replace harness connectors.

#### 2. CHECK WIRING HARNESS

Check the wiring harness externals.

Is the inspection result normal?

- YES >> GO TO 3.  
NO >> Replace wiring harness.

#### 3. REPLACE AIR BAG DIAGNOSIS SENSOR UNIT

1. Replace air bag diagnosis sensor unit. Refer to [SR-25, "Exploded View"](#).
2. Perform DTC confirmation procedure. Refer to [SRC-150, "DTC Logic"](#).

# B1218, B1219, B1220, B1221, B1222, B1223 DIAGNOSIS SENSOR UNIT

< DTC/CIRCUIT DIAGNOSIS >

---

Is DTC detected?

YES >> GO TO 1.

NO >> INSPECTION END

A

B

C

D

E

F

G

**SRC**

I

J

K

L

M

N

O

P

# DIAGNOSIS SENSOR UNIT

< ECU DIAGNOSIS INFORMATION >

## ECU DIAGNOSIS INFORMATION

### DIAGNOSIS SENSOR UNIT

#### DTC Index

INFOID:000000005174369

Diagnostic item	Explanation	Reference page	
NO DTC IS DETECTED.	When malfunction is indicated by the "AIR BAG" warning lamp in User mode	<p>Low battery voltage (Less than 9 V)</p> <ul style="list-style-type: none"> <li>Self-diagnosis result "SELF-DIAG [PAST]" (previously stored in the memory) might not be erased after repair</li> <li>Intermittent malfunction has been detected in the past</li> </ul>	<p><a href="#">PG-3, "How to Handle Battery".</a></p> <p><a href="#">SRC-15, "Diagnosis with Air Bag Warning Lamp", SRC-20, "CONSULT-III Function".</a></p>
	No malfunction is detected	—	
CONTROL UNIT [B1001-B1015]	Air bag diagnosis sensor unit is malfunctioning or out of the specified specification	<ul style="list-style-type: none"> <li><a href="#">SRC-22, "DTC Logic".</a></li> <li><a href="#">SRC-24, "DTC Logic".</a></li> <li><a href="#">SRC-26, "DTC Logic".</a></li> </ul>	
OCCUPANT SENS C/U [UNIT FAIL] [B1017] [B1020] [B1021]	Malfunction occurs in Occupant Classification System control unit	<a href="#">SRC-28, "DTC Logic".</a>	
OCCUPANT SENS [UNIT FAIL] [B1018]	Malfunction occurs in Occupant Classification System sensor	<a href="#">SRC-30, "DTC Logic".</a>	
OCCUPANT SENS C/U [COMM FAIL] [B1022]	Malfunction occurs in Occupant Classification System control unit, circuit of Occupant Classification System control unit air bag diagnosis sensor unit, or air bag diagnosis sensor unit	<a href="#">SRC-32, "DTC Logic".</a>	
PASS A/B INDCTR CKT [B1023]	Front passenger air bag OFF indicator circuit is open or shorted to ground or the circuits are shorted each other	<a href="#">SRC-34, "DTC Logic".</a>	
OCS SENSOR [B1025] [B1032] [B1048]	Malfunction occurs in Occupant Classification System control unit, circuit of Occupant Classification System control unit air bag diagnosis sensor unit, or air bag diagnosis sensor unit	<a href="#">SRC-36, "DTC Logic".</a>	
CONTROL UNIT [B1026-B1031]	Air bag diagnosis sensor unit is malfunctioning or out of the specified specification	<a href="#">SRC-38, "DTC Logic".</a>	
CRASH ZONE SEN [UNIT FAIL] [B1033] [B1034]	Crash zone sensor is malfunctioning	<a href="#">SRC-40, "DTC Logic".</a>	
CRASH ZONE SEN [COMM FAIL] [B1035] [UNMATCH] [B1036]	Crash zone sensor is malfunctioning or out of the specified specification	<a href="#">SRC-42, "DTC Logic".</a>	
CRASH ZONE SEN1 [B1037] [B1039] [B1041]	Crash zone sensor is malfunctioning	<a href="#">SRC-44, "DTC Logic".</a>	
CONTROL UNIT [B1042-B1047]	Air bag diagnosis sensor unit is malfunctioning or out of the specified specification	<a href="#">SRC-46, "DTC Logic".</a>	



# DIAGNOSIS SENSOR UNIT

## < ECU DIAGNOSIS INFORMATION >

Diagnostic item	Explanation	Reference page
DRIVER AIRBAG MODULE [OPEN] [B1049] [B1054]	Driver air bag module circuit is open (including the spiral cable)	<a href="#">SRC-48, "DTC Logic".</a>
DRIVER AIRBAG MODULE [VB-SHORT] [B1050] [B1055]	Driver air bag module circuit is shorted to some power supply circuit (including the spiral cable)	<a href="#">SRC-50, "DTC Logic".</a>
DRIVER AIRBAG MODULE [GND-SHORT] [B1051] [B1056]	Driver air bag module circuit is shorted to ground (including the spiral cable)	<a href="#">SRC-52, "DTC Logic".</a>
DRIVER AIRBAG MODULE [SHORT] [B1052] [B1057]	Driver air bag module circuits are shorted to each other (including spiral cable)	<a href="#">SRC-54, "DTC Logic".</a>
CONTROL UNIT [B1058-B1063]	Air bag diagnosis sensor unit is malfunctioning or out of the specified specification	<a href="#">SRC-56, "DTC Logic".</a>
ASSIST A/B MODULE [OPEN] [B1065] [B1070]	Front passenger air bag module circuit is open	<a href="#">SRC-58, "DTC Logic".</a>
ASSIST A/B MODULE [VB-SHORT] [B1066] [B1071]	Front passenger air bag module circuit is shorted to some power supply circuit	<a href="#">SRC-60, "DTC Logic".</a>
ASSIST A/B MODULE [GND-SHORT] [B1067] [B1072]	Front passenger air bag module circuit is shorted to ground	<a href="#">SRC-62, "DTC Logic".</a>
ASSIST A/B MODULE [SHORT] [B1068] [B1073]	Front passenger air bag module circuits are shorted to each other	<a href="#">SRC-64, "DTC Logic".</a>
CONTROL UNIT [B1074-B1079]	Air bag diagnosis sensor unit is malfunctioning or out of the specified specification	<a href="#">SRC-66, "DTC Logic".</a>
DRIVER AIRBAG MODULE [SHORT] [B1080] [B1096]	Driver air bag module circuits are shorted to each other (including spiral cable)	<a href="#">SRC-68, "DTC Logic".</a>
PRE-TEN FRONT RH [OPEN] [B1081]	Front RH seat belt pre-tensioner circuit is open	<a href="#">SRC-70, "DTC Logic".</a>
PRE-TEN FRONT RH [VB-SHORT] [B1082]	Front RH seat belt pre-tensioner circuit is shorted to some power supply circuit	<a href="#">SRC-72, "DTC Logic".</a>
PRE-TEN FRONT RH [GND-SHORT] [B1083]	Front RH seat belt pre-tensioner circuit is shorted to ground	<a href="#">SRC-74, "DTC Logic".</a>
PRE-TEN FRONT RH [SHORT] [B1084]	Front RH seat belt pre-tensioner circuits are shorted to each other	<a href="#">SRC-76, "DTC Logic".</a>
PRE-TEN FRONT LH [OPEN] [B1086]	Front LH seat belt pre-tensioner circuit is open	<a href="#">SRC-78, "DTC Logic".</a>
PRE-TEN FRONT LH [VB-SHORT] [B1087]	Front LH seat belt pre-tensioner circuit is shorted to some power supply circuit	<a href="#">SRC-80, "DTC Logic".</a>
PRE-TEN FRONT LH [GND-SHORT] [B1088]	Front LH seat belt pre-tensioner circuit is shorted to ground	<a href="#">SRC-82, "DTC Logic".</a>
PRE-TEN FRONT LH [SHORT] [B1089]	Front LH seat belt pre-tensioner circuits are shorted to each other	<a href="#">SRC-84, "DTC Logic".</a>

A  
B  
C  
D  
E  
F  
G  
I  
J  
K  
L  
M  
N  
O  
P

SRC

## DIAGNOSIS SENSOR UNIT

### < ECU DIAGNOSIS INFORMATION >

Diagnostic item	Explanation	Reference page
CONTROL UNIT [B1090-B1095]	Air bag diagnosis sensor unit is malfunctioning or out of the specified specification	<a href="#">SRC-86, "DTC Logic"</a> .
CONTROL UNIT [B1106-B1111]	Air bag diagnosis sensor unit is malfunctioning or out of the specified specification	<a href="#">SRC-88, "DTC Logic"</a> .
SATELLITE SENS RH [UNIT FAIL] [B1113-B1114]	RH satellite sensor is malfunctioning	<a href="#">SRC-90, "DTC Logic"</a> .
SATELLITE SENS RH [COMM FAIL] [B1115] [UNMATCH] [B1116]	RH satellite sensor is malfunctioning or out of the specified specification	<a href="#">SRC-92, "DTC Logic"</a> .
SATELLITE SENS LH [UNIT FAIL] [B1118-B1119]	LH satellite sensor is malfunctioning	<a href="#">SRC-94, "DTC Logic"</a> .
SATELLITE SENS LH [COMM FAIL] [B1120] [UNMATCH] [B1121]	LH satellite sensor is malfunctioning or out of the specified specification	<a href="#">SRC-96, "DTC Logic"</a> .
CONTROL UNIT [B1122-B1127]	Air bag diagnosis sensor unit is malfunctioning or out of the specified specification	<a href="#">SRC-98, "DTC Logic"</a> .
SIDE MODULE RH [OPEN] [B1129]	Front RH side air bag module circuit is open	<a href="#">SRC-100, "DTC Logic"</a> .
SIDE MODULE RH [VB-SHORT] [B1130]	Front RH side air bag module circuit is shorted to some power supply circuit	<a href="#">SRC-102, "DTC Logic"</a> .
SIDE MODULE RH [GND-SHORT] [B1131]	Front RH side air bag module circuit is shorted to ground	<a href="#">SRC-104, "DTC Logic"</a> .
SIDE MODULE RH [SHORT] [B1132]	Front LH seat belt pre-tensioner circuits are shorted to each other	<a href="#">SRC-106, "DTC Logic"</a> .
SIDE MODULE LH [OPEN] [B1134]	Front LH side air bag module circuit is open	<a href="#">SRC-108, "DTC Logic"</a> .
SIDE MODULE LH [VB-SHORT] [B1135]	Front LH side air bag module circuit is shorted to some power supply circuit	<a href="#">SRC-110, "DTC Logic"</a> .
SIDE MODULE LH [GND-SHORT] [B1136]	Front LH side air bag module circuit is shorted to ground	<a href="#">SRC-112, "DTC Logic"</a> .
SIDE MODULE LH [SHORT] [B1137]	Front LH side air bag module circuits are shorted to each other	<a href="#">SRC-114, "DTC Logic"</a> .
CONTROL UNIT [B1138-B1143]	Air bag diagnosis sensor unit is malfunctioning or out of the specified specification	<a href="#">SRC-116, "DTC Logic"</a> .
CONTROL UNIT [B1144]	Air bag diagnosis sensor unit is malfunctioning or out of the specified specification	<a href="#">SRC-118, "DTC Logic"</a> .
CURTAIN MODULE RH [OPEN] [B1145]	RH side curtain air bag module circuit is open	<a href="#">SRC-119, "DTC Logic"</a> .
CURTAIN MODULE RH [VB-SHORT] [B1146]	RH side curtain air bag module circuit is shorted to some power supply circuit	<a href="#">SRC-121, "DTC Logic"</a> .

## DIAGNOSIS SENSOR UNIT

### < ECU DIAGNOSIS INFORMATION >

Diagnostic item	Explanation	Reference page
CURTAIN MODULE RH [GND-SHORT] [B1147]	RH side curtain air bag module circuit is shorted to ground	<a href="#">SRC-123, "DTC Logic"</a> .
CURTAIN MODULE RH [SHORT] [B1148]	RH side curtain air bag module circuits are shorted to each other	<a href="#">SRC-125, "DTC Logic"</a> .
CURTAIN MODULE LH [OPEN] [B1150]	LH side curtain air bag module circuit is open	<a href="#">SRC-127, "DTC Logic"</a> .
CURTAIN MODULE LH [VB-SHORT] [B1151]	LH side curtain air bag module circuit is shorted to some power supply circuits	<a href="#">SRC-129, "DTC Logic"</a> .
CURTAIN MODULE LH [GND-SHORT] [B1152]	LH side curtain air bag module circuit is shorted to ground	<a href="#">SRC-131, "DTC Logic"</a> .
CURTAIN MODULE LH [SHORT] [B1153]	LH side curtain air bag module circuits are shorted to each other	<a href="#">SRC-133, "DTC Logic"</a> .
CONTROL UNIT [B1154-B1159]	Air bag diagnosis sensor unit is malfunctioning or out of the specified specification	<a href="#">SRC-135, "DTC Logic"</a> .
CONTROL UNIT [B1170-B1175]	Air bag diagnosis sensor unit is malfunctioning or out of the specified specification	<a href="#">SRC-137, "DTC Logic"</a> .
CONTROL UNIT [B1186-B1191]	Air bag diagnosis sensor unit is malfunctioning or out of the specified specification	<a href="#">SRC-139, "DTC Logic"</a> .
CONTROL UNIT [B1202-B1207]	Air bag diagnosis sensor unit is malfunctioning or out of the specified specification	<a href="#">SRC-141, "DTC Logic"</a> .
FRONTAL COLLISION DETECTION [B1209]	Front seat belt pre-tensioner and front air bag is deployed	<a href="#">SRC-143, "DTC Logic"</a> .
SIDE COLLISION DETECTION [B1210]	Front side air bag and side curtain air bag are deployed	<a href="#">SRC-144, "DTC Logic"</a> .
ROLLOVER DETECTION [B1211]	Front seat belt pre-tensioner, side curtain air bag module are deployed because of rollover detection	<a href="#">SRC-145, "DTC Logic"</a> .
RH1 SAT-SENS [B1212-B1214]	RH satellite sensor is malfunctioning	<a href="#">SRC-146, "DTC Logic"</a> .
LH1 SAT-SENS [B1215-B1217]	LH satellite sensor is malfunctioning	<a href="#">SRC-148, "DTC Logic"</a> .
CONTROL UNIT [B1218-B1223]	Air bag diagnosis sensor unit is malfunctioning or out of the specified specification	<a href="#">SRC-150, "DTC Logic"</a> .

A  
B  
C  
D  
E  
F  
G  
I  
J  
K  
L  
M  
N  
O  
P

SRC

# DIAGNOSIS SENSOR UNIT

< ECU DIAGNOSIS INFORMATION >

## Wiring Diagram - SRS AIR BAG CONTROL SYSTEM -

INFOID:000000005174370

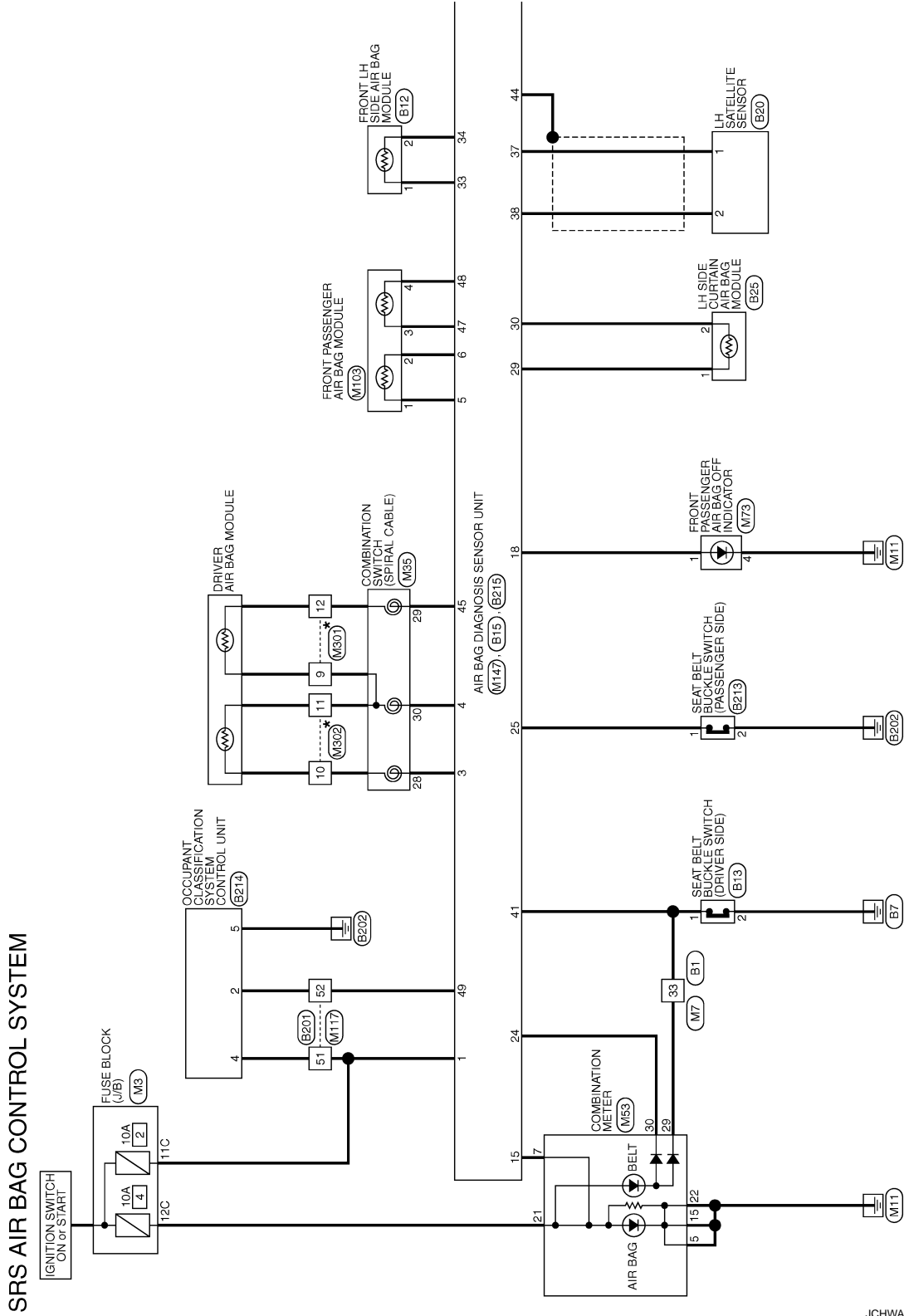

\*: This connector is not shown in "Harness Layout".

2009/07/16

JCHWA0378GB

# DIAGNOSIS SENSOR UNIT

< ECU DIAGNOSIS INFORMATION >

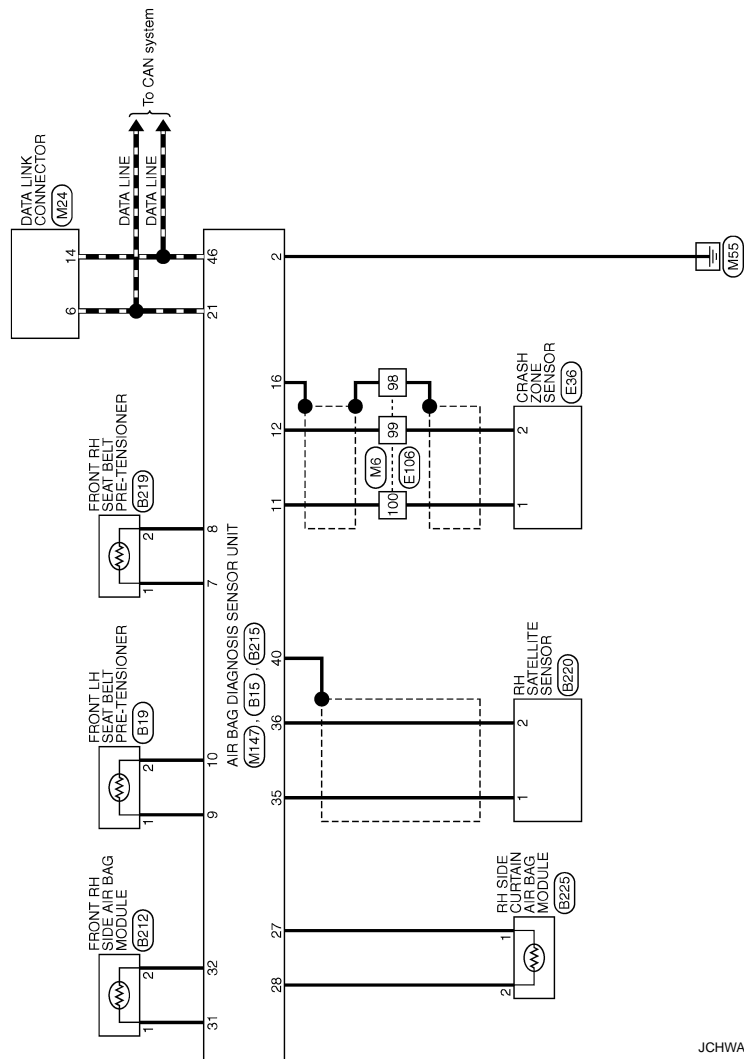

A  
B  
C  
D  
E  
F  
G  
SRC  
I  
J  
K  
L  
M  
N  
O  
P

# DIAGNOSIS SENSOR UNIT

< ECU DIAGNOSIS INFORMATION >

## SRS AIR BAG CONTROL SYSTEM

Connector No.	B1
Connector Name	WIRE TO WIRE
Connector Type	TH00PW-CS16-TM4



Terminal No.	Color of Wire	Signal Name [Specification]
3	R	-
4	G	-
5	G	-
6	SB	-
7	V	-
8	B	-
12	L	-
13	P	-
14	GR	-
15	LG	-
17	W	-
18	L	-
19	P	-
20	BR	-
21	SHIELD	-
22	Y	-
24	P	-
27	B	-
28	R	-
29	W	-
30	SHIELD	-
31	SHIELD	-
32	W	-
33	SB	-
34	L	-
35	P	-
36	L	-
37	P	-
38	BR	-
39	Y	-
44	Y	-
45	GR	-
46	G	-
47	B	-
48	G	-
49	G	-
50	V	-
60	P	-
61	L	-
62	SHIELD	-

63	R	-
64	G	-
65	SHIELD	-
66	W	-
67	V	-
68	SB	-
69	SHIELD	-
70	W	-
73	SB	-
74	L	-
75	W	-
76	BR	-
77	R	-
78	P	-
79	GR	-
83	O	-
85	V	-
86	LG	-
87	Y	-
88	R	-
89	B	-
90	O	-
91	G	-
92	BR	-
93	G	-
94	SB	-
95	G	-
96	Y	-
98	W	-
99	GR	-

Connector No.	B12
Connector Name	FRONT LH SIDE AIR BAG MODULE
Connector Type	TK02FY-EX-IV



Terminal No.	Color of Wire	Signal Name [Specification]
1	Y	-
2	Y	-

Connector No.	B13
Connector Name	SEAT BELT BUCKLE SWITCH (DRIVER SIDE)
Connector Type	TH04PW-NH



Terminal No.	Color of Wire	Signal Name [Specification]
1	SB	-
2	B	-

Connector No.	B15
Connector Name	AIR BAG DIAGNOSIS SENSOR UNIT
Connector Type	TK12FY-2V-EX

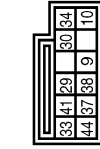

Terminal No.	Color of Wire	Signal Name [Specification]
9	Y	PLH(+)
10	Y	PLH(-)
29	Y	GLH(-)
30	Y/B	GLH(-)
33	Y	SLH(+)
34	Y	SLH(-)
37	P	SATELLITE LH(+)
38	L	SATELLITE LH(-)
41	SB	LH BUCKLE SW INPUT
44	SHIELD	GND

Connector No.	B19
Connector Name	FRONT LH SEAT BELT PRE-TENSIONER
Connector Type	ACA02FY-2V



Terminal No.	Color of Wire	Signal Name [Specification]
1	Y	-
2	Y	-

Connector No.	B20
Connector Name	LH SATELLITE SENSOR
Connector Type	HK02FY-1V-EX-LC



Terminal No.	Color of Wire	Signal Name [Specification]
1	P	-
2	L	-

Connector No.	B25
Connector Name	LH SIDE CURTAIN AIR BAG MODULE
Connector Type	ACA02FY-2V



Terminal No.	Color of Wire	Signal Name [Specification]
1	Y	-
2	Y/B	-

JCHWA0380GB

# DIAGNOSIS SENSOR UNIT

< ECU DIAGNOSIS INFORMATION >

## SRS AIR BAG CONTROL SYSTEM

Connector No.	B201
Connector Name	WIRE TO WIRE
Connector Type	TH04FW-TM4

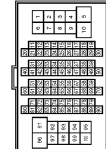

Terminal No.	Color of Wire	Signal Name [Specification]
1	W	-
2	R	-
3	GR	-
4	O	-
7	LG	-
10	W	-
15	SB	-
16	V	-
17	BR	-
26	BR	-
27	L	-
28	Y	-
28	Y	-
30	GR	-
31	R	-
32	V	-
35	G	-
36	R	-
57	W	-
58	B	-
58	B	-
58	SHIELD	-
60	LG	-
61	W	-
62	BR	-
63	P	-
64	L	-
65	G	-
66	P	-
67	L	-
68	SHIELD	-
69	V	-
70	Y	-
71	SB	-
72	W	-
72	BR	-
75	Y	-
80	V	-
81	SB	-

82	LG	-
83	P	-
84	R	-
85	L	-
86	O	-
87	L	-
88	P	-
91	V	-
92	R	-
94	G	-
95	SB	-
96	G	-
97	G	-
98	R	-
99	P	-
100	L	-

Connector No.	B212
Connector Name	FRONT RH SIDE AIR BAG MODULE
Connector Type	TK02FY-EX-1V



Connector No.	B214
Connector Name	OCCUPANT CLASSIFICATION SYSTEM CONTROL UNIT
Connector Type	TH08FW-NH

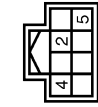

Terminal No.	Color of Wire	Signal Name [Specification]
2	V	COMMUNICATION
4	R	IGN
5	B	GND

Connector No.	B215
Connector Name	AIR BAG DIAGNOSIS SENSOR UNIT
Connector Type	TK12FY-1V-EX



Terminal No.	Color of Wire	Signal Name [Specification]
7	Y	PRH(-)
8	Y	PRH(-)
25	LG	RH BUCKLE SW INPUT
27	Y	GRH(-)
28	Y/B	GRH(-)
31	Y	SRH(-)
32	Y	SRH(-)
35	G	SATELLITE RH(+)
36	R	SATELLITE RH(-)
40	SHIELD	GND

Connector No.	B219
Connector Name	FRONT RH SEAT BELT PRE-TENSIONER
Connector Type	ACA02FY-2V



Terminal No.	Color of Wire	Signal Name [Specification]
1	Y	-
2	Y	-

Connector No.	B220
Connector Name	RH SATELLITE SENSOR
Connector Type	HK02FY-1V-EX-LC



Terminal No.	Color of Wire	Signal Name [Specification]
1	G	-
2	R	-

Connector No.	B225
Connector Name	RH SIDE CURTAIN AIR BAG MODULE
Connector Type	ACA02FY-2V



Terminal No.	Color of Wire	Signal Name [Specification]
1	Y	-
2	Y/B	-

JCHWA0381GB

A  
B  
C  
D  
E  
F  
G  
H  
I  
J  
K  
L  
M  
N  
O  
P

SRC

# DIAGNOSIS SENSOR UNIT

< ECU DIAGNOSIS INFORMATION >

## SRS AIR BAG CONTROL SYSTEM

Connector No.	E106
Connector Name	CRASH ZONE SENSOR
Connector Type	HK02FY-1Y-EX-LC



Terminal No.	Color of Wire	Signal Name [Specification]
1	P	-
2	L	-

Connector No.	E105
Connector Name	WIRE TO WIRE
Connector Type	TH00FW-CS16-TM4

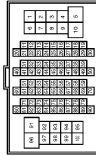

Terminal No.	Color of Wire	Signal Name [Specification]
1	R	-
2	W	-
3	B	-
4	GR	-
5	GR	-
8	Y	-
9	BR	-
10	O	-
11	SB	-
12	O	-
13	L	-
14	R	-
15	P	-
16	V	-
17	SB	-
18	V	-
20	O	-
21	I	-
22	V	-
23	G	-

79	L	-	[Without ICC]
80	SB	-	-
81	R	-	-
82	SB	-	-
83	O	-	-
84	G	-	-
85	L	-	-
86	P	-	-
87	V	-	-
89	GR	-	-
90	SHIELD	-	-
91	W	-	-
92	Y	-	-
93	V	-	-
94	LG	-	-
95	O	-	-
96	P	-	-
97	R	-	-
98	SHIELD	-	-
99	L	-	-
100	P	-	-

Connector No.	M3
Connector Name	FUSE BLOCK (J/B)
Connector Type	NS12FW-CS



Terminal No.	Color of Wire	Signal Name [Specification]
6C	R	-
7C	B	-
9C	O	-
10C	L	-
11C	R	-
12C	O	-

24	P	-	-
25	Y	-	-
26	V	-	-
27	W	-	-
28	G	-	-
31	O	-	-
32	W	-	-
33	B	-	-
34	R	-	-
35	G	-	-
36	SHIELD	-	-
37	V	-	-
38	BR	-	-
39	O	-	-
41	W	-	-
42	G	-	-
43	BR	-	-
45	W	-	-
49	L	-	-
50	P	-	-
51	L	-	-
52	L	-	-
53	P	-	-
54	O	-	-
56	BR	-	-
57	BR	-	-
58	W	-	-
59	W	-	-
60	LG	-	-
61	G	-	-
62	SB	-	-
63	W	-	-
64	B	-	-
65	G	-	-
66	R	-	-
67	SHIELD	-	-
68	Y	-	-
69	LG	-	-
70	W	-	-
71	R	-	-
72	Y	-	-
73	B	-	-
74	BR	-	[With ICC]
74	L	-	[Without ICC]
75	G	-	[With ICC]
75	W	-	[Without ICC]
76	W	-	[With ICC]
76	Y	-	[Without ICC]
77	R	-	[With ICC]
77	P	-	[Without ICC]
78	L	-	[With ICC]
78	L	-	[Without ICC]
78	BR	-	[With ICC]
78	BR	-	[Without ICC]
79	Y	-	[With ICC]



# DIAGNOSIS SENSOR UNIT

< ECU DIAGNOSIS INFORMATION >

## SRS AIR BAG CONTROL SYSTEM

Connector No.	M6
Connector Name	WIRE TO WIRE
Connector Type	TH80MM-CS16-TM4

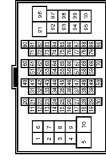

Terminal No.	Color of Wire	Signal Name [Specification]
1	W	-
2	R	-
3	B	-
4	SHIELD	-
5	G	-
8	Y	-
9	BR	-
10	R	-
11	BR	-
12	O	- [With ICC]
13	L	- [Without ICC]
14	B	-
15	P	- [With ICC]
16	V	- [Without ICC]
17	SB	- [With ICC]
18	V	- [Without ICC]
20	O	- [With ICC]
21	L	- [Without ICC]
22	W	- [With ICC]
23	P	- [Without ICC]
24	BR	-
25	Y	-
26	V	-
27	G	-
28	G	-
31	L	-
32	G	-
33	B	-
34	W	-
35	R	-
36	SHIELD	-
37	V	-
38	O	-
39	BR	-
41	W	-
42	O	-
43	O	-
45	W	-

49	L	-
50	P	-
51	BR	-
52	-	-
53	P	-
54	Y	-
56	BR	-
57	G	-
59	W	-
60	L	-
61	G	-
62	SB	-
63	G	-
64	B	-
65	W	-
66	R	-
67	SHIELD	-
68	Y	-
69	GR	-
70	LG	-
71	LG	-
72	Y	-
73	SB	-
74	BR	- [With ICC]
74	L	- [Without ICC]
75	G	-
76	W	- [With ICC]
76	GR	- [Without ICC]
77	R	- [With ICC]
77	P	- [Without ICC]
78	L	- [With ICC]
78	R	- [Without ICC]
79	Y	- [With ICC]
79	W	- [Without ICC]
80	SB	-
81	SB	-
82	SB	-
83	V	-
84	G	-
85	L	-
86	P	-
87	W	-
89	GR	-
90	SHIELD	-
91	W	-
92	Y	-
93	BR	-
94	P	-
95	GR	-
96	W	-
97	L	-
98	SHIELD	-

99	V	-
100	SB	-

Connector No.	M7
Connector Name	WIRE TO WIRE
Connector Type	TH80MM-CS16-TM4

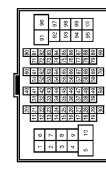

Terminal No.	Color of Wire	Signal Name [Specification]
3	SB	- [With automatic drive positioner]
3	W	- [Without automatic drive positioner]
5	G	-
6	O	-
7	W	-
8	B	-
12	G	-
12	Y	-
13	G	-
14	B	-
14	Y	-
15	G	-
17	W	-
18	L	-
19	P	-
20	BR	-
21	SHIELD	-
22	Y	-
24	V	-
27	B	-
28	W	-
29	R	-
30	SHIELD	-
31	L	-
32	P	-
33	SB	-
34	L	-
35	P	-
36	L	-
37	P	-
38	BR	-
39	Y	-
44	L	-
45	GR	-
46	B	-
47	G	-

49	V	-
50	R	-
60	P	-
61	L	-
62	SHIELD	-
63	R	-
64	G	-
65	SHIELD	-
66	SB	-
67	V	-
68	LG	-
69	SHIELD	-
70	W	-
73	G	-
74	R	-
75	W	-
76	W	-
77	B	-
78	P	-
79	GR	-
83	O	-
85	LG	-
86	R	-
87	Y	-
88	W	-
89	BR	-
90	O	-
91	G	-
92	V	-
93	BR	-
94	V	-
95	G	-
96	Y	-
98	W	-
99	R	-

A  
B  
C  
D  
E  
F  
G  
H  
I  
J  
K  
L  
M  
N  
O  
P

SRC

# DIAGNOSIS SENSOR UNIT

< ECU DIAGNOSIS INFORMATION >

## SRS AIR BAG CONTROL SYSTEM

Connector No.	M24
Connector Name	DATA LINK CONNECTOR
Connector Type	BD16FW

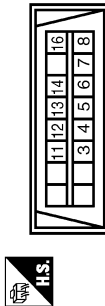

Terminal No.	Color of Wire	Signal Name [Specification]
3	G	
4	B	
5	B	
6	L	
7	V	
8	G	
11	R	
14	P	
16	Y	

Connector No.	M35
Connector Name	COMBINATION SWITCH (SPIRAL CABLE)
Connector Type	TK08FY-EX-1V



Terminal No.	Color of Wire	Signal Name [Specification]
23	R	
28	Y	
29	Y	
30	Y	

Connector No.	M53
Connector Name	COMBINATION METER
Connector Type	TH40FW-IH



Terminal No.	Color of Wire	Signal Name [Specification]
1	GR	BATTERY POWER SUPPLY
2	LG	COMMUNICATION SIGNAL (METER->AMP.)
3	GR	COMMUNICATION SIGNAL (AMP->METER)
5	B	GROUND
6	P	ALTERNATOR SIGNAL
7	BR	AIR BAG SIGNAL
10	G	SECURITY SIGNAL
15	B	GROUND
16	B	METER CONTROL SWITCH GROUND
19	B	ILL GND
20	R	ILL
21	O	IGNITION POWER SUPPLY
22	B	GROUND
24	BR	COMMUNICATION SIGNAL (LCD->AMP.)
26	R	COMMUNICATION SIGNAL (AMP->LCD)
28	R	VEHICLE SPEED SIGNAL (PULSE)
27	V	PARKING BRAKE SWITCH SIGNAL
28	W	BRAKE FLUID LEVEL SWITCH SIGNAL
29	SB	SEAT BELT BUCKLE SWITCH SIGNAL (DRIVER SIDE)
30	G	SEAT BELT BUCKLE SWITCH SIGNAL (PASSENGER SIDE)
31	L	WASHER LEVEL SWITCH SIGNAL
33	B	ILLUMINATION CONTROL
36	LG	SELECT SWITCH SIGNAL
37	SB	ENTER SWITCH SIGNAL
38	L	TRIP A/B RESET SWITCH SIGNAL
39	P	ILLUMINATION CONTROL SWITCH SIGNAL (-)
40	O	ILLUMINATION CONTROL SWITCH SIGNAL (+)

Connector No.	M73
Connector Name	FRONT PASSENGER AIR BAG OFF INDICATOR
Connector Type	TH04MM-IH

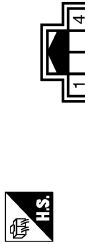

Terminal No.	Color of Wire	Signal Name [Specification]
1	R	
4	B	

Connector No.	M103
Connector Name	FRONT PASSENGER AIR BAG MODULE
Connector Type	RK04FY-BD



Terminal No.	Color of Wire	Signal Name [Specification]
1	Y	
2	Y	
3	Y	
4	Y	

JCHWA0384GB

# DIAGNOSIS SENSOR UNIT

< ECU DIAGNOSIS INFORMATION >

A  
B  
C  
D  
E  
F  
G  
H  
I  
J  
K  
L  
M  
N  
O  
P

SRC

## SRS AIR BAG CONTROL SYSTEM

Connector No.	M117
Connector Name	WIRE TO WIRE
Connector Type	TH80MW-CS16-TM4

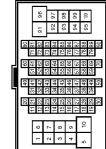

Terminal No.	Color of Wire	Signal Name [Specification]
1	L	-
2	G	-
3	GR	-
4	SB	-
7	W	-
10	W	-
15	SB	-
16	V	-
17	BR	-
26	BR	-
27	LG	-
28	Y	-
29	Y	-
30	V	-
51	R	-
52	L	-
55	W	-
56	B	-
57	R	-
58	G	-
59	SHIELD	-
60	V	-
61	LG	-
62	BR	-
63	L	-
64	LG	-
65	B	-
66	R	-
67	W	-
68	SHIELD	-
69	V	-
70	Y	-
71	SB	-
72	W	-
73	G	-
75	W	-
80	V	-
81	SB	-

82	V	-
83	P	-
84	R	-
85	L	-
86	O	-
87	L	-
88	P	-
91	V	-
92	G	-
94	G	-
95	W	-
96	G	-
97	Y	-
98	BR	-
99	V	- [With BOSE audio]
99	P	- [Without BOSE audio]
100	SB	- [With BOSE audio]
100	L	- [Without BOSE audio]

Connector No.	M147
Connector Name	AIR BAG DIAGNOSIS SENSOR UNIT
Connector Type	TK28FY-EX-SC

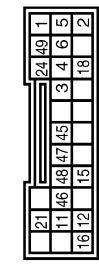

Terminal No.	Color of Wire	Signal Name [Specification]
1	R	IGN
2	B	GND
3	Y	DRI (+)
4	Y	DRI (-) DR2 (-)
5	Y	ASI (+)
6	Y	ASI (-)
11	SB	EC2S (+)
12	V	EC2S (-)
15	BR	AIR BAG W/L
16	SHIELD	GND
18	R	CUTOFF TELLTALE
21	L	CANH
24	G	SEAT BELT
45	Y	DR2 (+)
46	P	CANH
47	Y	AS2 (+)
48	Y	AS2 (-)
49	L	ODS INPUT

Connector No.	M301
Connector Name	DRIVER AIR BAG MODULE
Connector Type	ACA02FY-2V



Terminal No.	Color of Wire	Signal Name [Specification]
9	-	-
12	-	-

Connector No.	M302
Connector Name	DRIVER AIR BAG MODULE
Connector Type	ACA02FY-2V



Terminal No.	Color of Wire	Signal Name [Specification]
10	-	-
11	-	-

# SRS AIR BAG WARNING LAMP DOES NOT TURN OFF

< SYMPTOM DIAGNOSIS >

---

## SYMPTOM DIAGNOSIS

### SRS AIR BAG WARNING LAMP DOES NOT TURN OFF

#### Diagnosis Procedure

INFOID:000000005174371

#### 1. CHECK FRONT AIR BAG MODULE

---

Check the deployment of front air bag module.

Is air bag module deployed?

YES >> Refer to [SR-11. "Removal and Installation"](#) or [SR-17. "Removal and Installation"](#).

NO >> GO TO 2.

#### 2. CHECK AIR BAG FUSE

---

Check 10A fuse [No.2, located in fuse block (J/B)].

Is the inspection result normal?

YES >> GO TO 3.

NO >> Replace the fuse.

#### 3. CHECK HARNESS CONNECTOR

---

Check the harness connector.

Is the inspection result normal?

YES >> GO TO 4.

NO >> Replace harness connectors.

#### 4. CHECK WIRING HARNESS

---

Check the wiring harness externals.

Is the inspection result normal?

YES >> GO TO 5.

NO >> Replace wiring harness.

#### 5. REPLACE AIR BAG DIAGNOSIS SENSOR UNIT

---

1. Replace air bag diagnosis sensor unit. Refer to [SR-25. "Removal and Installation"](#).

2. Check air bag warning lamp operation.

Is the inspection result normal?

YES >> INSPECTION END

NO >> GO TO 1.

# SRS AIR BAG WARNING LAMP DOES NOT TURN ON

< SYMPTOM DIAGNOSIS >

## SRS AIR BAG WARNING LAMP DOES NOT TURN ON

### Diagnosis Procedure

INFOID:000000005174372

#### 1.CHECK METER FUSE

Check 10A fuse [No.4, located in fuse block (J/B)].

Is the inspection result normal?

YES >> GO TO 2.

NO >> Replace the fuse.

#### 2.CHECK HARNESS CONNECTOR

Check the harness connector.

Is the inspection result normal?

YES >> GO TO 3.

NO >> Replace harness connectors.

#### 3.CHECK WIRING HARNESS

Check the wiring harness externals.

Is the inspection result normal?

YES >> GO TO 4.

NO >> Replace wiring harness.

#### 4.REPLACE AIR BAG DIAGNOSIS SENSOR UNIT

1. Replace air bag diagnosis sensor unit. Refer to [SR-25, "Removal and Installation"](#).

2. Check air bag warning lamp operation.

Is the inspection result normal?

YES >> INSPECTION END

NO >> GO TO 1.

A  
B  
C  
D  
E  
F  
G  
SRC  
I  
J  
K  
L  
M  
N  
O  
P

# PASSENGER SEAT BELT WARNING SYSTEM

< SYMPTOM DIAGNOSIS >

---

## PASSENGER SEAT BELT WARNING SYSTEM

### Diagnosis Procedure

INFOID:000000005174373

#### 1.CHECK THE SYSTEM 1

---

Check the seat belt warning lamp function.

Seat belt warning lamp turns ON in the following conditions.

- Driver seat belt is fastened.
- Occupant is on passenger seat.
- Passenger seat belt is not fastened.

Is the inspection result normal?

YES >> GO TO 2.

NO >> Check the followings.

- Harness between air bag diagnosis sensor unit and combination meter.
- Seat belt buckle switch (passenger side) circuit.
- Seat belt buckle switch (passenger side).

If these are OK, replace air bag diagnosis sensor unit.

#### 2.CHECK THE SYSTEM 2

---

Check the seat belt warning lamp function.

Seat belt warning lamp turns OFF in the following conditions.

- Driver seat belt is fastened.
- Occupant is on passenger seat.
- Passenger seat belt is fastened.

Is the inspection result normal?

YES >> System is OK.

NO >> Check the followings.

- Seat belt buckle switch (passenger side) circuit.
- Seat belt buckle switch (passenger side).

If these are OK, replace air bag diagnosis sensor unit.

# PRECAUTIONS

< PRECAUTION >

## PRECAUTION

### PRECAUTIONS

#### Precaution for Supplemental Restraint System (SRS) "AIR BAG" and "SEAT BELT PRE-TENSIONER"

INFOID:000000005174374

The Supplemental Restraint System such as "AIR BAG" and "SEAT BELT PRE-TENSIONER", used along with a front seat belt, helps to reduce the risk or severity of injury to the driver and front passenger for certain types of collision. This system includes seat belt switch inputs and dual stage front air bag modules. The SRS system uses the seat belt switches to determine the front air bag deployment, and may only deploy one front air bag, depending on the severity of a collision and whether the front occupants are belted or unbelted. Information necessary to service the system safely is included in the "SRS AIR BAG" and "SEAT BELT" of this Service Manual.

#### **WARNING:**

- To avoid rendering the SRS inoperative, which could increase the risk of personal injury or death in the event of a collision which would result in air bag inflation, all maintenance must be performed by an authorized NISSAN/INFINITI dealer.
- Improper maintenance, including incorrect removal and installation of the SRS, can lead to personal injury caused by unintentional activation of the system. For removal of Spiral Cable and Air Bag Module, see the "SRS AIR BAG".
- Do not use electrical test equipment on any circuit related to the SRS unless instructed to in this Service Manual. SRS wiring harnesses can be identified by yellow and/or orange harnesses or harness connectors.

#### PRECAUTIONS WHEN USING POWER TOOLS (AIR OR ELECTRIC) AND HAMMERS

#### **WARNING:**

- When working near the Air Bag Diagnosis Sensor Unit or other Air Bag System sensors with the ignition ON or engine running, DO NOT use air or electric power tools or strike near the sensor(s) with a hammer. Heavy vibration could activate the sensor(s) and deploy the air bag(s), possibly causing serious injury.
- When using air or electric power tools or hammers, always switch the ignition OFF, disconnect the battery, and wait at least 3 minutes before performing any service.

#### Service

INFOID:000000005174375

- Do not use electrical test equipment to check SRS circuits unless instructed to in this Service Manual.
- Before servicing the SRS, turn ignition switch OFF, disconnect battery negative terminal and wait at least 3 minutes.  
For approximately 3 minutes after the battery negative terminal is removed, it is still possible for the air bag and seat belt pre-tensioner to deploy. Therefore, do not work on any SRS connectors or wires until at least 3 minutes have elapsed.
- Diagnosis sensor unit must always be installed with their arrow marks "⇐" pointing towards the front of the vehicle for proper operation. Also check diagnosis sensor unit for cracks, deformities or rust before installation and replace as required.
- The spiral cable must be aligned in the neutral position since its rotations are limited. Do not turn steering wheel and column after removal of steering gear.
- Handle air bag module carefully. Always place driver and front passenger air bag modules with the pad side facing upward and seat mounted front side air bag module standing with the stud bolt side facing down.
- Conduct self-diagnosis to check entire SRS for proper function after replacing any components.
- After air bag inflates, the front instrument panel assembly should be replaced if damaged.
- Always replace instrument panel pad following front passenger air bag deployment.

#### Occupant Classification System Precaution

INFOID:000000005174376

- Replace occupant classification system control unit and passenger front seat cushion as an assembly. Refer to [SE-132, "Removal and Installation"](#).