

SECTION **EXT**
EXTERIOR

A
B
C
D
E
F
G
H
I
J
EXT
L
M
N
O
P

CONTENTS

SYMPTOM DIAGNOSIS	3	FENDER PROTECTOR	25
SQUEAK AND RATTLE TROUBLE DIAG- NOSES	3	FENDER PROTECTOR	25
Work Flow	3	FENDER PROTECTOR : Exploded View	25
Inspection Procedure	5	FENDER PROTECTOR : Removal and Installa- tion	25
Diagnostic Worksheet	7	REAR WHEEL HOUSE PROTECTOR	26
PRECAUTION	9	REAR WHEEL HOUSE PROTECTOR : Exploded View	27
PRECAUTIONS	9	REAR WHEEL HOUSE PROTECTOR : Removal and Installation	27
Precaution for Supplemental Restraint System (SRS) "AIR BAG" and "SEAT BELT PRE-TEN- SIONER"	9	CENTER MUD GUARD	29
Precautions Necessary for Steering Wheel Rota- tion After Battery Disconnection	9	Exploded View	29
Precaution for Procedure without Cowl Top Cover... 10	10	Removal and Installation	29
Precaution for Work	10	FLOOR SIDE FAIRING	31
PREPARATION	11	Exploded View	31
PREPARATION	11	Removal and Installation	31
Special Service Tools	11	FILLET MOLDING	32
Commercial Service Tools	11	Exploded View	32
REMOVAL AND INSTALLATION	12	Removal and Installation	32
FRONT BUMPER	12	ROOF RAIL	34
Exploded View	12	Exploded View	34
Removal and Installation	13	Removal and Installation	34
REAR BUMPER	16	ROOF SIDE MOLDING	37
Exploded View	16	Exploded View	37
Removal and Installation	17	Removal and Installation	37
FRONT GRILLE	20	DOOR SASH MOLDING	39
Exploded View	20	Exploded View	39
Removal and Installation	20	Removal and Installation	39
COWL TOP	22	DOOR OUTSIDE MOLDING	41
Exploded View	22	Exploded View	41
Removal and Installation	23	Removal and Installation	41
		DOOR OUTSIDE LOWER MOLDING	44
		Exploded View	44

Removal and Installation	44	BACK DOOR FINISHER	48
DOOR PARTING SEAL	46	Exploded View	48
Exploded View	46	Removal and Installation	48
Removal and Installation	46		

SQUEAK AND RATTLE TROUBLE DIAGNOSES

< SYMPTOM DIAGNOSIS >

SYMPTOM DIAGNOSIS

SQUEAK AND RATTLE TROUBLE DIAGNOSES

Work Flow

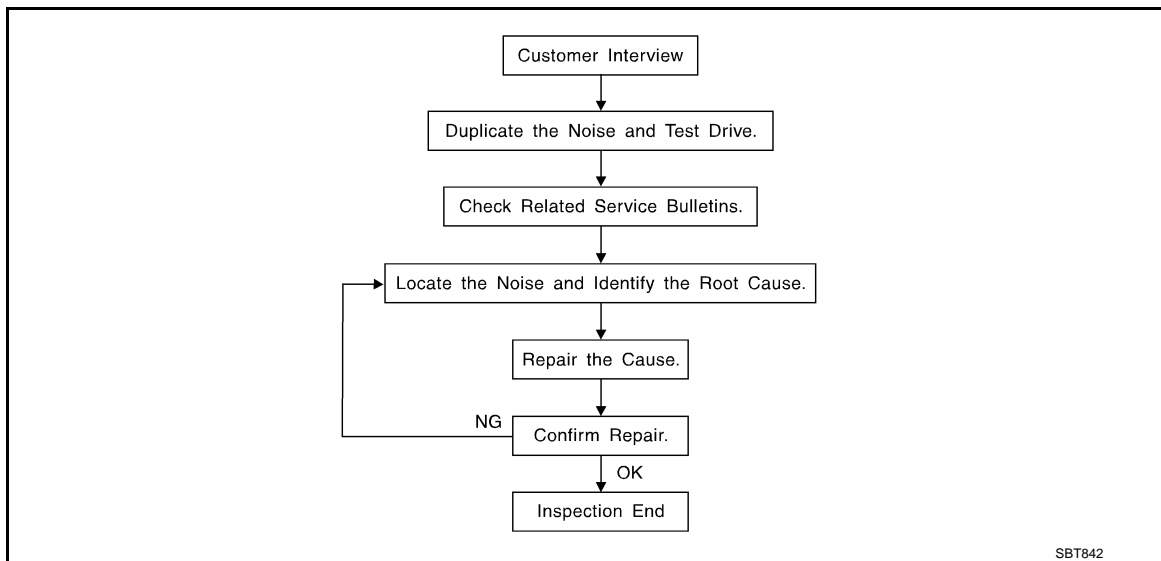

CUSTOMER INTERVIEW

Interview the customer if possible, to determine the conditions that exist when the noise occurs. Use the Diagnostic Worksheet during the interview to document the facts and conditions when the noise occurs and any of customer's comments; refer to [EXT-7, "Diagnostic Worksheet"](#). This information is necessary to duplicate the conditions that exist when the noise occurs.

- The customer may not be able to provide a detailed description or the location of the noise. Attempt to obtain all the facts and conditions that exist when the noise occurs (or does not occur).
- If there is more than one noise in the vehicle, perform a diagnosis and repair the noise that the customer is concerned about. This can be accomplished by performing a cruise test on the vehicle with the customer.
- After identifying the type of noise, isolate the noise in terms of its characteristics. The noise characteristics are provided so the customer, service adviser and technician are all speaking the same language when defining the noise.
- Squeak – (Like tennis shoes on a clean floor)
Squeak characteristics include the light contact/fast movement/brought on by road conditions/hard surfaces = higher pitch noise/softer surfaces = lower pitch noises/edge to surface = chirping
- Creak – (Like walking on an old wooden floor)
Creak characteristics include firm contact/slow movement/twisting with a rotational movement/pitch dependent on materials/often brought on by activity.
- Rattle – (Like shaking a baby rattle)
Rattle characteristics include the fast repeated contact/vibration or similar movement/loose parts/missing clip or fastener/incorrect clearance.
- Knock – (Like a knock on a door)
Knock characteristics include hollow sounding/sometimes repeating/often brought on by driver action.
- Tick – (Like a clock second hand)
Tick characteristics include gentle contacting of light materials/loose components/can be caused by driver action or road conditions.
- Thump – (Heavy, muffled knock noise)
Thump characteristics include softer knock/dead sound often brought on by activity.
- Buzz – (Like a bumblebee)
Buzz characteristics include high frequency rattle/firm contact.
- Often the degree of acceptable noise level will vary depending up on the person. A noise that you may judge as acceptable may be very irritating to the customer.
- Weather conditions, especially humidity and temperature, may have a great effect on noise level.

DUPLICATE THE NOISE AND TEST DRIVE

SQUEAK AND RATTLE TROUBLE DIAGNOSES

< SYMPTOM DIAGNOSIS >

If possible, drive the vehicle with the customer until the noise is duplicated. Note any additional information on the Diagnostic Worksheet regarding the conditions or location of the noise. This information can be used to duplicate the same conditions when you confirm the repair.

If the noise can be duplicated easily during the test drive, to help identify the source of the noise, try to duplicate the noise with the vehicle stopped by doing one or all of the following:

- 1) Close a door.
 - 2) Tap or push/pull around the area where the noise appears to be coming from.
 - 3) Rev the engine.
 - 4) Use a floor jack to recreate vehicle "twist".
 - 5) At idle, apply engine load (electrical load, half-clutch on M/T models, drive position on A/T models).
 - 6) Raise the vehicle on a hoist and hit a tire with a rubber hammer.
- Drive the vehicle and attempt to duplicate the conditions the customer states exist when the noise occurs.
 - If it is difficult to duplicate the noise, drive the vehicle slowly on an undulating or rough road to stress the vehicle body.

CHECK RELATED SERVICE BULLETINS

After verifying the customer concern or symptom, check ASIST for Technical Service Bulletins (TSBs) related to that concern or symptom.

If a TSB relates to the symptom, follow the procedure to repair the noise.

LOCATE THE NOISE AND IDENTIFY THE ROOT CAUSE

1. Narrow down the noise to a general area. To help pinpoint the source of the noise, use a listening tool (Chassis Ear: J-39570, Engine Ear and mechanics stethoscope).
2. Narrow down the noise to a more specific area and identify the cause of the noise by:
 - Removing the components in the area that you suspect the noise is coming from.
Do not use too much force when removing clips and fasteners, otherwise clips and fastener can be broken or lost during the repair, resulting in the creation of new noise.
 - Tapping or pushing/pulling the component that you suspect is causing the noise.
Do not tap or push/pull the component with excessive force, otherwise the noise will be eliminated only temporarily.
 - Feeling for a vibration with your hand by touching the component(s) that you suspect is (are) causing the noise.
 - Placing a piece of paper between components that you suspect are causing the noise.
 - Looking for loose components and contact marks.
Refer to [EXT-5. "Inspection Procedure"](#).

REPAIR THE CAUSE

- If the cause is a loose component, tighten the component securely.
- If the cause is insufficient clearance between components:
 - Separate components by repositioning or loosening and retightening the component, if possible.
 - Insulate components with a suitable insulator such as urethane pads, foam blocks, felt cloth tape or urethane tape. A Nissan Squeak and Rattle Kit (J-43980) is available through your authorized Nissan Parts Department.

CAUTION:

Never use excessive force as many components are constructed of plastic and may be damaged.

NOTE:

Always check with the Parts Department for the latest parts information.

The following materials are contained in the Nissan Squeak and Rattle Kit (J-43980). Each item can be ordered separately as needed.

URETHANE PADS [1.5 mm (0.059 in) thick]

Insulates connectors, harness, etc.

76268-9E005: 100 × 135 mm (3.94 × 5.31 in)/76884-71L01: 60 × 85 mm (2.36 × 3.35 in)/76884-71L02: 15 × 25 mm (0.59 × 0.98 in)

INSULATOR (Foam blocks)

Insulates components from contact. Can be used to fill space behind a panel.

73982-9E000: 45 mm (1.77 in) thick, 50 × 50 mm (1.97 × 1.97 in)/73982-

50Y00: 10 mm (0.39 in) thick, 50 × 50 mm (1.97 × 1.97 in)

INSULATOR (Light foam block)

80845-71L00: 30 mm (1.18 in) thick, 30 × 50 mm (1.18 × 1.97in)

FELT CLOTHTAPE

Used to insulate where movement does not occur. Ideal for instrument panel applications.

SQUEAK AND RATTLE TROUBLE DIAGNOSES

< SYMPTOM DIAGNOSIS >

68370-4B000: 15 × 25 mm (0.59 × 0.98 in) pad/68239-13E00: 5 mm (0.20 in) wide tape roll

The following materials, not found in the kit, can also be used to repair squeaks and rattles.

UHMW (TEFLON) TAPE

Insulates where slight movement is present. Ideal for instrument panel applications.

SILICONE GREASE

Used in place of UHMW tape that will be visible or not fit. Will only last a few months.

SILICONE SPRAY

Use when grease cannot be applied.

DUCT TAPE

Use to eliminate movement.

CONFIRM THE REPAIR

Confirm that the cause of a noise is repaired by test driving the vehicle. Operate the vehicle under the same conditions as when the noise originally occurred. Refer to the notes on the Diagnostic Worksheet.

Inspection Procedure

INFOID:000000006342828

Refer to Table of Contents for specific component removal and installation information.

INSTRUMENT PANEL

Most incidents are caused by contact and movement between:

1. The cluster lid A and instrument panel
2. Acrylic lens and combination meter housing
3. Instrument panel to front pillar garnish
4. Instrument panel to windshield
5. Instrument panel mounting pins
6. Wiring harnesses behind the combination meter
7. A/C defroster duct and duct joint

These incidents can usually be located by tapping or moving the components to duplicate the noise or by pressing on the components while driving to stop the noise. Most of these incidents can be repaired by applying felt cloth tape or silicon spray (in hard to reach areas). Urethane pads can be used to insulate wiring harness.

CAUTION:

Never use silicone spray to isolate a squeak or rattle. If you saturate the area with silicone, you will not be able to recheck the repair.

CENTER CONSOLE

Components to pay attention to include:

1. Shifter assembly cover to finisher
2. A/C control unit and cluster lid C
3. Wiring harnesses behind audio and A/C control unit

The instrument panel repair and isolation procedures also apply to the center console.

DOORS

Pay attention to the:

1. Finisher and inner panel making a slapping noise
2. Inside handle escutcheon to door finisher
3. Wiring harnesses tapping
4. Door striker out of alignment causing a popping noise on starts and stops

Tapping or moving the components or pressing on them while driving to duplicate the conditions can isolate many of these incidents. You can usually insulate the areas with felt cloth tape or insulator foam blocks from the Nissan Squeak and Rattle Kit (J-43980) to repair the noise.

TRUNK

Trunk noises are often caused by a loose jack or loose items put into the trunk by the owner.

In addition look for:

1. Trunk lid dumpers out of adjustment
2. Trunk lid striker out of adjustment

A

B

C

D

E

F

G

H

I

J

EXT

L

M

N

O

P

SQUEAK AND RATTLE TROUBLE DIAGNOSES

< SYMPTOM DIAGNOSIS >

3. The trunk lid torsion bars knocking together
4. A loose license plate or bracket

Most of these incidents can be repaired by adjusting, securing or insulating the item(s) or component(s) causing the noise.

SUNROOF/HEADLINING

Noises in the sunroof/headlining area can often be traced to one of the following:

1. Sunroof lid, rail, linkage or seals making a rattle or light knocking noise
2. Sunvisor shaft shaking in the holder
3. Front or rear windshield touching headlining and squeaking

Again, pressing on the components to stop the noise while duplicating the conditions can isolate most of these incidents. Repairs usually consist of insulating with felt cloth tape.

SEATS

When isolating seat noise it's important to note the position the seat is in and the load placed on the seat when the noise is present. These conditions should be duplicated when verifying and isolating the cause of the noise.

Cause of seat noise include:

1. Headrest rods and holder
2. A squeak between the seat pad cushion and frame
3. The rear seatback lock and bracket

These noises can be isolated by moving or pressing on the suspected components while duplicating the conditions under which the noise occurs. Most of these incidents can be repaired by repositioning the component or applying urethane tape to the contact area.

UNDERHOOD

Some interior noise may be caused by components under the hood or on the engine wall. The noise is then transmitted into the passenger compartment.

Causes of transmitted under hood noise include:

1. Any component mounted to the engine wall
2. Components that pass through the engine wall
3. Engine wall mounts and connectors
4. Loose radiator mounting pins
5. Hood bumpers out of adjustment
6. Hood striker out of adjustment

These noises can be difficult to isolate since they cannot be reached from the interior of the vehicle. The best method is to secure, move or insulate one component at a time and test drive the vehicle. Also, engine RPM or load can be changed to isolate the noise. Repairs can usually be made by moving, adjusting, securing, or insulating the component causing the noise.

SQUEAK AND RATTLE TROUBLE DIAGNOSES

< SYMPTOM DIAGNOSIS >

Diagnostic Worksheet

INFOID:000000006342829



SQUEAK & RATTLE DIAGNOSTIC WORKSHEET

Dear Infiniti Customer:

We are concerned about your satisfaction with your Infiniti vehicle. Repairing a squeak or rattle sometimes can be very difficult. To help us fix your Infiniti right the first time, please take a moment to note the area of the vehicle where the squeak or rattle occurs and under what conditions. You may be asked to take a test drive with a service consultant or technician to ensure we confirm the noise you are hearing.

I. WHERE DOES THE NOISE COME FROM? (circle the area of the vehicle)

The illustrations are for reference only, and may not reflect the actual configuration of your vehicle.

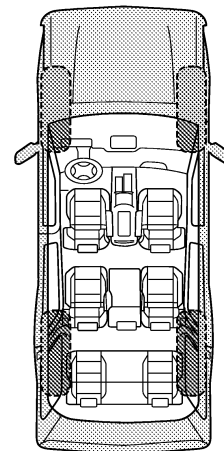
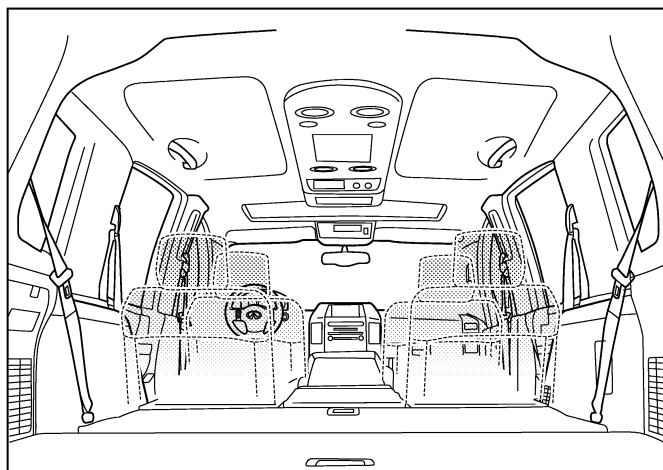
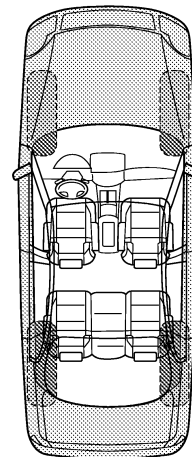
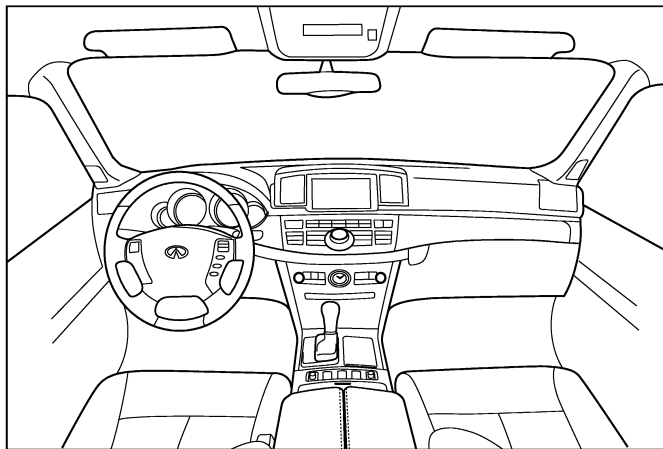

Continue to page 2 of the worksheet and briefly describe the location of the noise or rattle. In addition, please indicate the conditions which are present when the noise occurs.

PIIB8741E

A
B
C
D
E
F
G
H
I
J
EXT
L
M
N
O
P

SQUEAK AND RATTLE TROUBLE DIAGNOSES

< SYMPTOM DIAGNOSIS >

SQUEAK & RATTLE DIAGNOSTIC WORKSHEET - page 2

Briefly describe the location where the noise occurs:

II. WHEN DOES IT OCCUR? (please check the boxes that apply)

- | | |
|---|--|
| <input type="checkbox"/> anytime | <input type="checkbox"/> after sitting out in the rain |
| <input type="checkbox"/> 1st time in the morning | <input type="checkbox"/> when it is raining or wet |
| <input type="checkbox"/> only when it is cold outside | <input type="checkbox"/> dry or dusty conditions |
| <input type="checkbox"/> only when it is hot outside | <input type="checkbox"/> other: |

III. WHEN DRIVING:

- through driveways
- over rough roads
- over speed bumps
- only about ____ mph
- on acceleration
- coming to a stop
- on turns: left, right or either (circle)
- with passengers or cargo
- other: _____
- after driving ____ miles or ____ minutes

IV. WHAT TYPE OF NOISE

- squeak (like tennis shoes on a clean floor)
- creak (like walking on an old wooden floor)
- rattle (like shaking a baby rattle)
- knock (like a knock at the door)
- tick (like a clock second hand)
- thump (heavy, muffled knock noise)
- buzz (like a bumble bee)

TO BE COMPLETED BY DEALERSHIP PERSONNEL

Test Drive Notes:

	YES	NO	Initials of person performing
Vehicle test driven with customer	<input type="checkbox"/>	<input type="checkbox"/>	_____
- Noise verified on test drive	<input type="checkbox"/>	<input type="checkbox"/>	_____
- Noise source located and repaired	<input type="checkbox"/>	<input type="checkbox"/>	_____
- Follow up test drive performed to confirm repair	<input type="checkbox"/>	<input type="checkbox"/>	_____

VIN: _____ Customer Name: _____
W.O.# _____ Date: _____

This form must be attached to Work Order

PIIB8742E

PRECAUTIONS

< PRECAUTION >

PRECAUTION

PRECAUTIONS

Precaution for Supplemental Restraint System (SRS) "AIR BAG" and "SEAT BELT PRE-TENSIONER"

INFOID:000000006342830

The Supplemental Restraint System such as "AIR BAG" and "SEAT BELT PRE-TENSIONER", used along with a front seat belt, helps to reduce the risk or severity of injury to the driver and front passenger for certain types of collision. This system includes seat belt switch inputs and dual stage front air bag modules. The SRS system uses the seat belt switches to determine the front air bag deployment, and may only deploy one front air bag, depending on the severity of a collision and whether the front occupants are belted or unbelted. Information necessary to service the system safely is included in the "SRS AIR BAG" and "SEAT BELT" of this Service Manual.

WARNING:

Always observe the following items for preventing accidental activation.

- To avoid rendering the SRS inoperative, which could increase the risk of personal injury or death in the event of a collision that would result in air bag inflation, all maintenance must be performed by an authorized NISSAN/INFINITI dealer.
- Improper maintenance, including incorrect removal and installation of the SRS, can lead to personal injury caused by unintentional activation of the system. For removal of Spiral Cable and Air Bag Module, see "SRS AIR BAG".
- Never use electrical test equipment on any circuit related to the SRS unless instructed to in this Service Manual. SRS wiring harnesses can be identified by yellow and/or orange harnesses or harness connectors.

PRECAUTIONS WHEN USING POWER TOOLS (AIR OR ELECTRIC) AND HAMMERS

WARNING:

Always observe the following items for preventing accidental activation.

- When working near the Air Bag Diagnosis Sensor Unit or other Air Bag System sensors with the ignition ON or engine running, never use air or electric power tools or strike near the sensor(s) with a hammer. Heavy vibration could activate the sensor(s) and deploy the air bag(s), possibly causing serious injury.
- When using air or electric power tools or hammers, always switch the ignition OFF, disconnect the battery, and wait at least 3 minutes before performing any service.

Precautions Necessary for Steering Wheel Rotation After Battery Disconnection

INFOID:000000006342831

CAUTION:

Comply with the following cautions to prevent any error and malfunction.

- Before removing and installing any control units, first turn the ignition switch to the LOCK position, then disconnect both battery cables.
- After finishing work, confirm that all control unit connectors are connected properly, then re-connect both battery cables.
- Always use CONSULT to perform self-diagnosis as a part of each function inspection after finishing work. If a DTC is detected, perform trouble diagnosis according to self-diagnosis results.

For vehicle with steering lock unit, if the battery is disconnected or discharged, the steering wheel will lock and cannot be turned.

If turning the steering wheel is required with the battery disconnected or discharged, follow the operation procedure below before starting the repair operation.

OPERATION PROCEDURE

1. Connect both battery cables.

NOTE:

Supply power using jumper cables if battery is discharged.

2. Turn the ignition switch to ACC position.
(At this time, the steering lock will be released.)
3. Disconnect both battery cables. The steering lock will remain released with both battery cables disconnected and the steering wheel can be turned.

A
B
C
D
E
F
G
H
I
J
EXT
L
M
N
O
P

PRECAUTIONS

< PRECAUTION >

4. Perform the necessary repair operation.
5. When the repair work is completed, re-connect both battery cables. With the brake pedal released, turn the ignition switch from ACC position to ON position, then to LOCK position. (The steering wheel will lock when the ignition switch is turned to LOCK position.)
6. Perform self-diagnosis check of all control units using CONSULT.

Precaution for Procedure without Cowl Top Cover

INFOID:000000006342832

When performing the procedure after removing cowl top cover, cover the lower end of windshield with urethane, etc to prevent damage to windshield.

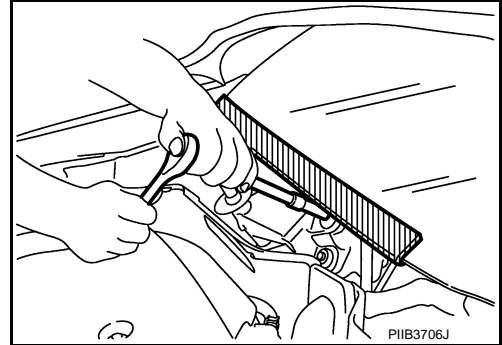

Precaution for Work

INFOID:000000006342833

- After removing and installing the opening/closing parts, be sure to carry out fitting adjustments to check their operation.
- Check the lubrication level, damage, and wear of each part. If necessary, grease or replace it.

PREPARATION

< PREPARATION >

PREPARATION

PREPARATION

Special Service Tools

INFOID:000000006342834

The actual shapes of Kent-Moore tools may differ from those of special service tools illustrated here.

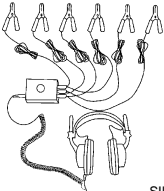
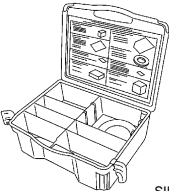
Tool number (Kent-Moore No.) Tool name	Description
<p>(J-39570) Chassis ear</p>  <p>SIIA0993E</p>	<p>Locates the noise</p>
<p>(J-43980) NISSAN Squeak and Rattle Kit</p>  <p>SIIA0994E</p>	<p>Repairs the cause of noise</p>

Commercial Service Tools

INFOID:000000006342835

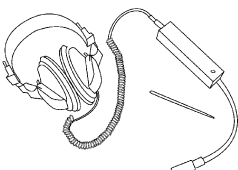
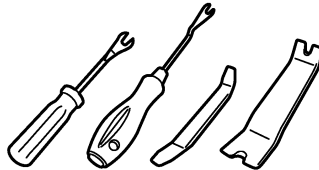
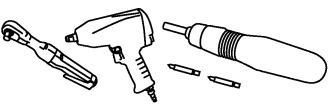
Tool name	Description
<p>Engine ear</p>  <p>SIIA0995E</p>	<p>Locates the noise</p>
<p>Remover tool</p>  <p>JMKIA3050ZZ</p>	<p>Removes clips, pawls and metal clips</p>
<p>Power tool</p>  <p>PIIB1407E</p>	

A

B

C

D

E

F

G

H

I

J

EXT

L

M

N

O

P

FRONT BUMPER

< REMOVAL AND INSTALLATION >

REMOVAL AND INSTALLATION

FRONT BUMPER

Exploded View

INFOID:000000006342836

SEC. 620

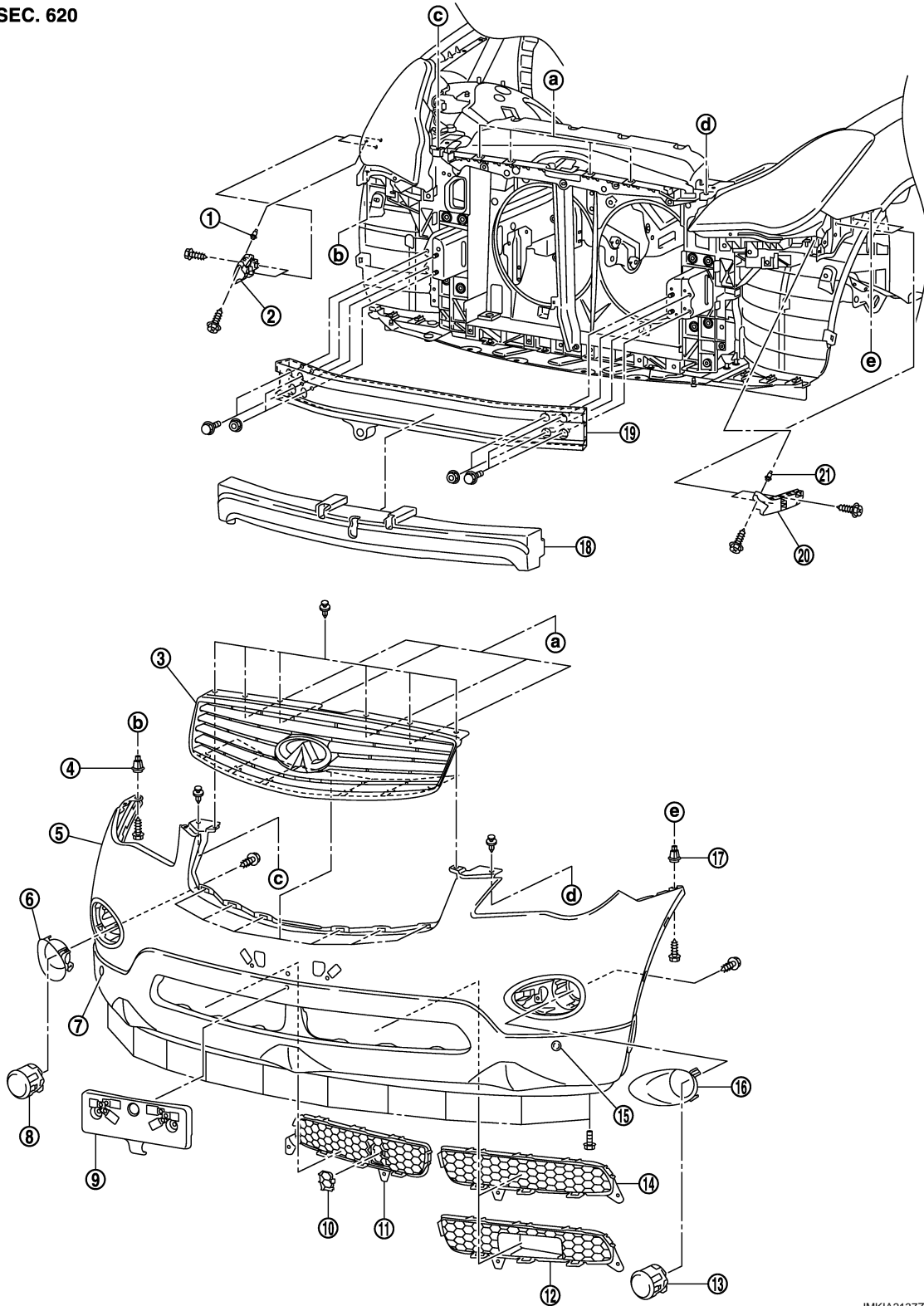

JMKIA2137ZZ

FRONT BUMPER

< REMOVAL AND INSTALLATION >

- | | | |
|---------------------------|--------------------------------------|-----------------------------------|
| 1. Grommet | 2. Bumper side bracket RH | 3. Front grille |
| 4. Bumper side grommet RH | 5. Bumper fascia assembly | 6. Fog lamp finisher RH |
| 7. Sonar sensor RH | 8. Front fog lamp RH | 9. License plate bracket |
| 10. Bumper bracket cover | 11. Bumper finisher RH | 12. Bumper finisher LH (with ICC) |
| 13. Front fog lamp LH | 14. Bumper finisher LH (without ICC) | 15. Sonar sensor LH |
| 16. Fog lamp finisher LH | 17. Bumper side grommet LH | 18. Energy absorber |
| 19. Bumper reinforcement | 20. Bumper side bracket LH | 21. Grommet |

Removal and Installation

INFOID:000000006342837

REMOVAL

CAUTION:

Bumper fascia is made of resin. Never apply strong force to it, and be careful to prevent contact with oil.

- Fully open hood assembly.
- Remove clips (A) of front bumper fascia upper side.

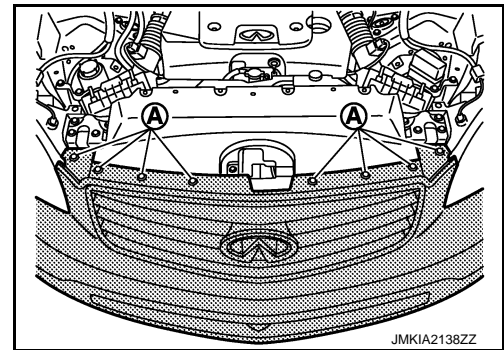

- Remove front fillet molding (1) fixing screws (A) (LH/RH).
- Remove front fillet molding fixing pawls and clip (LH/RH). Refer to [EXT-32, "Removal and Installation"](#).

- : Clip
 △ : Pawl

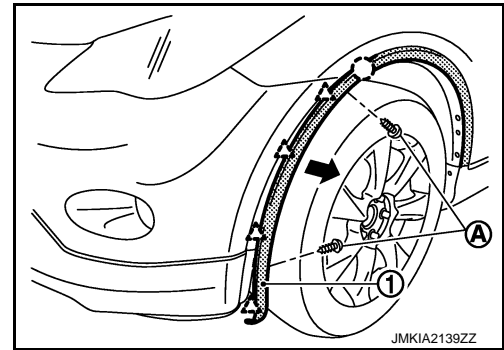

- Remove fender protector (1) fixing clip (A) and grommet (B) (LH/RH).

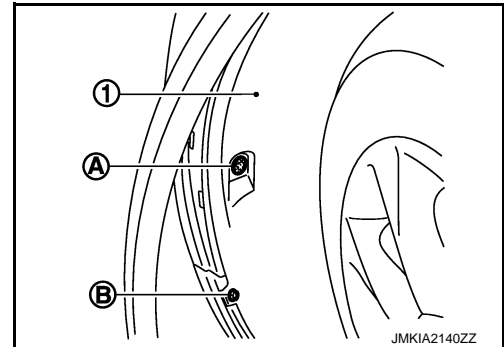

FRONT BUMPER

< REMOVAL AND INSTALLATION >

6. Remove bolts (A) of fixing engine lower cover and front fender protector.

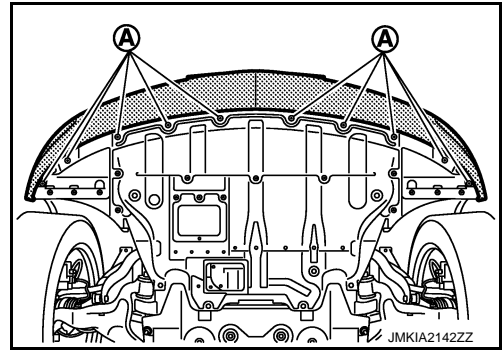

7. Remove bumper fascia assembly fixing screws (A) (LH/RH) with screwdriver (B).

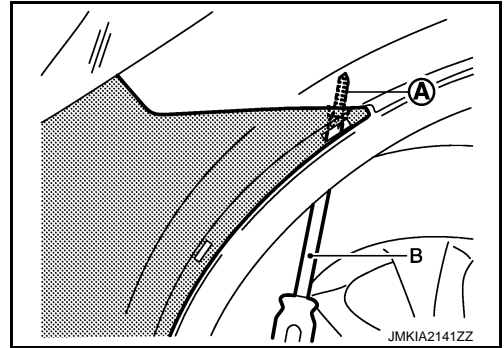

8. Pull the bumper fascia side toward the vehicle side to disengage the fitting of bumper side bracket and bumper fascia side.
9. Remove front camera harness clips (A), and then disconnect front camera harness connector (B). (with FRONT CAMERA).

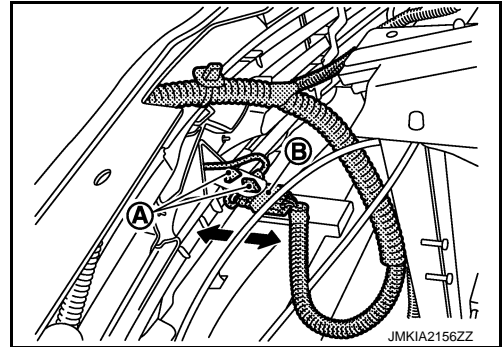

10. Remove bumper fascia assembly.

CAUTION:

When removing bumper fascia, 2 workers are required so as to prevent it from dropping.

11. Remove the following parts after removing bumper fascia.
- Hood seal assembly (front). Refer to [EXT-20, "Removal and Installation"](#).
 - Front grille. Refer to [EXT-20, "Removal and Installation"](#).
 - Sonar sensor (LH/RH). Refer to [AV-536, "FRONT : Removal and Installation"](#).
 - License plate bracket
 - Front bumper side bracket (LH/RH)
 - Front bumper finisher (LH/RH)
 - Fog lamp finisher (LH/RH)
12. Remove bumper energy absorber.
13. Remove bumper reinforcement mounting nuts and bolts, and then remove bumper reinforcement with power tool.

INSTALLATION

Install in the reverse order of removal.

NOTE:

FRONT BUMPER

< REMOVAL AND INSTALLATION >

After installing, perform fitting adjustment.

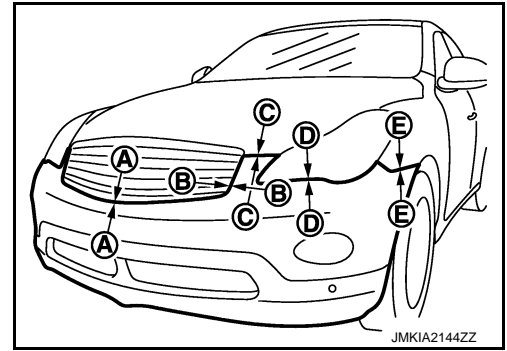

Portion		Clearance	Surface height difference
Front bumper – Front grille	A – A	0.2 – 2.8 mm (0.008 – 0.110 in)	—
Front bumper – Front grille	B – B	0.2 – 2.8 mm (0.008 – 0.110 in)	—
Front bumper – Hood	C – C	1.5 – 5.5 mm (0.059 – 0.217 in)	- 1.0 – 3.0 mm (- 0.039 – 0.118 in)
Front bumper – Headlamp	D – D	0.3 – 3.2 mm (0.012 – 0.126 in)	—
Front bumper – Front fender	E – E	0.0 – 0.8 mm (0.000 – 0.031 in)	- 0.2 – 1.8 mm (- 0.008 – 0.071 in)

A
B
C
D
E
F
G
H
I
J
L
M
N
O
P

EXT

REAR BUMPER

< REMOVAL AND INSTALLATION >

REAR BUMPER

Exploded View

INFOID:00000006342838

SEC. 850

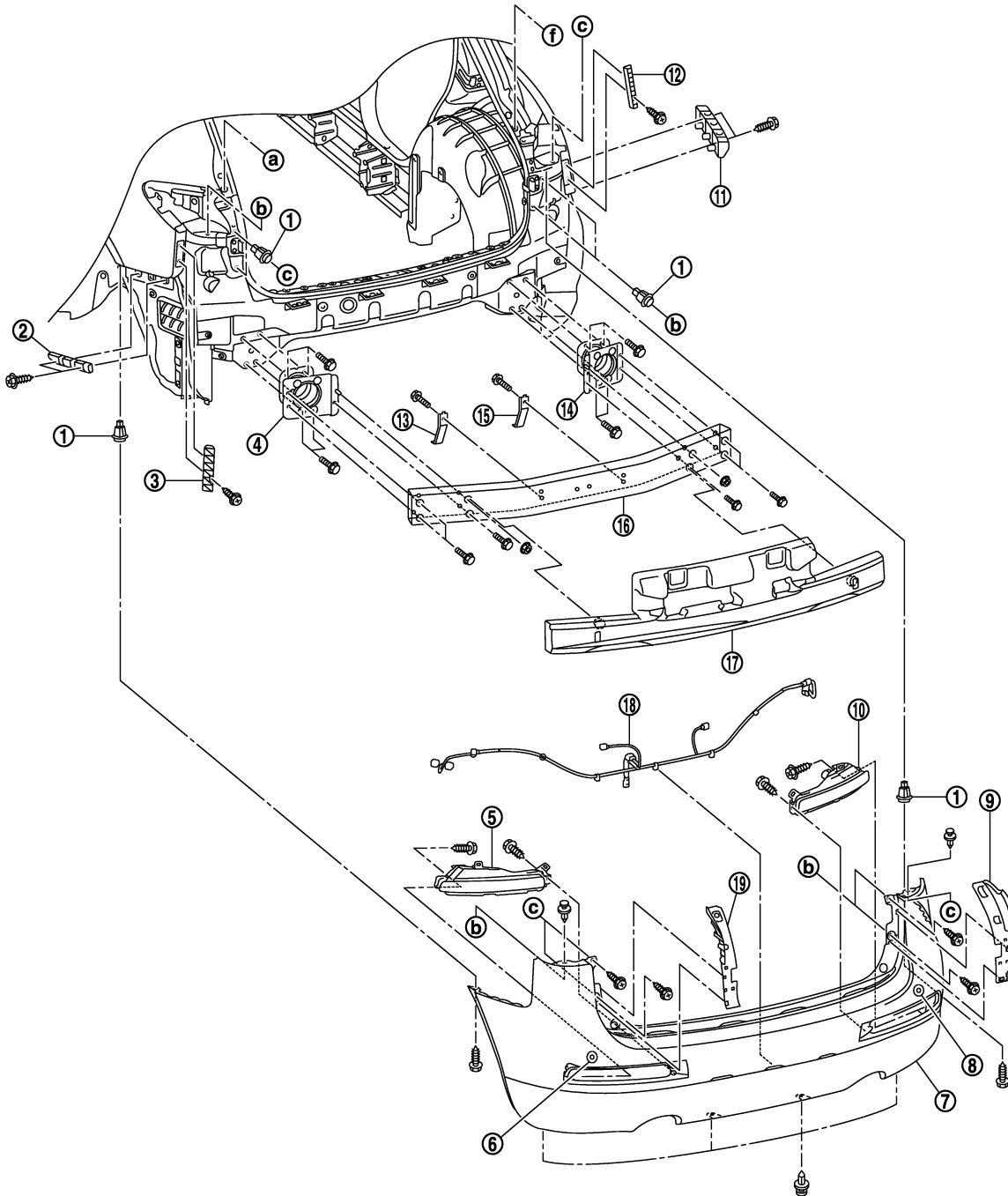

JMKIA2145ZZ

- | | | |
|---------------------------|-----------------------------|-----------------------------|
| 1. Grommet | 2. Bumper side bracket A LH | 3. Bumper side bracket B LH |
| 4. Bumper stay LH | 5. Rear combination lamp LH | 6. Sonar sensor LH |
| 7. Bumper fascia assembly | 8. Sonar sensor RH | 9. Bumper side cover RH |

REAR BUMPER

< REMOVAL AND INSTALLATION >

- | | | |
|------------------------------|------------------------------|------------------------------|
| 10. Rear combination lamp RH | 11. Bumper side bracket A RH | 12. Bumper side bracket B RH |
| 13. Bumper lower retainer LH | 14. Bumper stay RH | 15. Bumper lower retainer RH |
| 16. Bumper reinforcement | 17. Energy absorber | 18. Bumper sub harness |
| 19. Bumper side cover LH | | |

Removal and Installation

INFOID:000000006342839

REMOVAL

CAUTION:

Bumper fascia is made of resin. Never apply strong force to it, and be careful to prevent contact with oil.

1. Fully open back door.
2. Remove bumper side cover (1) fixing clips and pawls, and then remove bumper side cover (LH/RH).

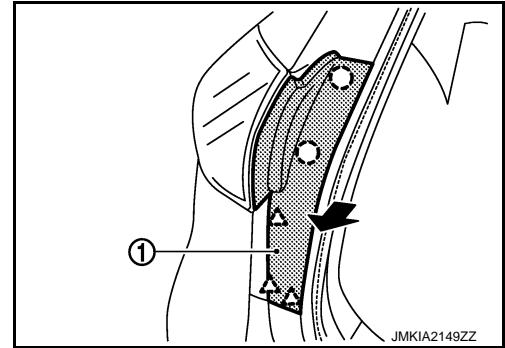
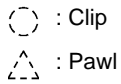

3. Remove rear combination lamp (LH/RH). Refer to [EXL-216, "Removal and Installation"](#).
4. Remove clip (A) and bolts (B) located under rear combination lamp (LH/RH).

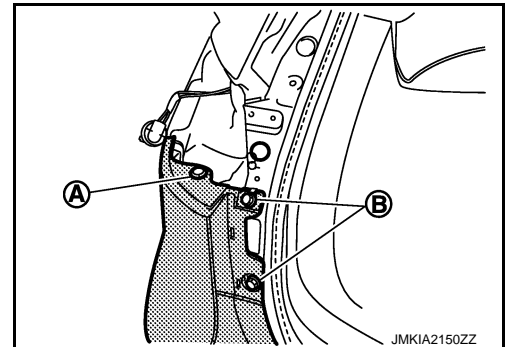

5. Remove rear fillet molding (1) fixing screws (A) (LH/RH).
6. Remove rear fillet molding fixing pawls and clip (LH/RH). Refer to [EXT-32, "Removal and Installation"](#).

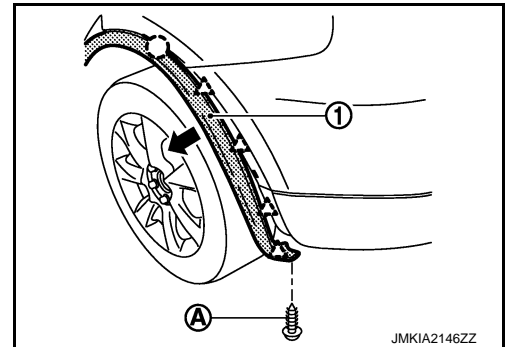
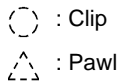

A
B
C
D
E
F
G
H
I
J
EXT
L
M
N
O
P

REAR BUMPER

< REMOVAL AND INSTALLATION >

7. Remove bumper fascia (1) fixing screws (A) (LH/RH).

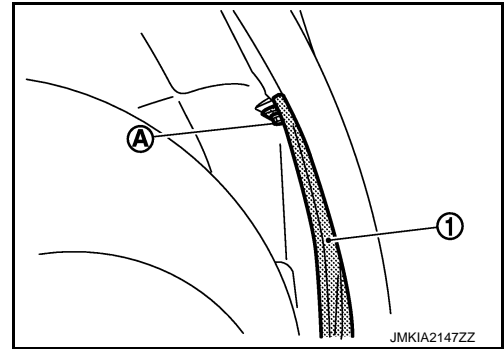

8. Remove clips (A) of bumper fascia underside.

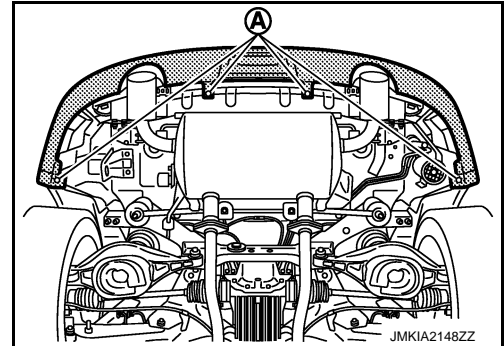

9. Pull to release bumper fascia assembly from bumper side bracket.

 : Pawl

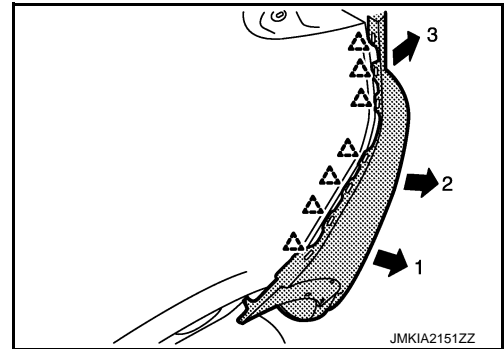

10. Disconnect bumper sub harness connector (A).

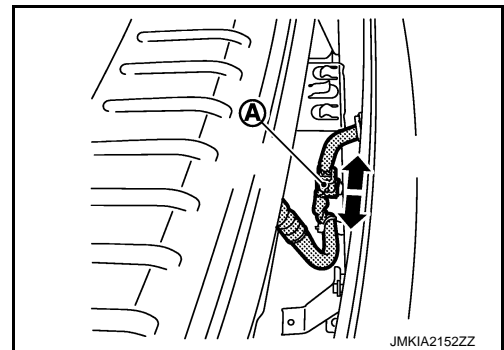

11. Remove bumper fascia assembly.

CAUTION:

When removing bumper fascia, 2 workers are required so as to prevent it from dropping.

12. Remove the following parts after removing bumper fascia.

- Rear turn signal lamp (LH/RH). Refer to [EXL-217, "Removal and Installation"](#).
- Sonar sensor. Refer to [AV-537, "REAR : Removal and Installation"](#).
- Bumper sub harness
- Bumper side bracket A
- Bumper side bracket B

13. Remove bumper energy absorber.

14. Remove license lamp harness clamps of bumper reinforcement.

REAR BUMPER

< REMOVAL AND INSTALLATION >

15. Remove bumper reinforcement mounting nuts, and then remove bumper reinforcement with power tool.

INSTALLATION

Install in the reverse order of removal.

NOTE:

After installing, perform fitting adjustment.

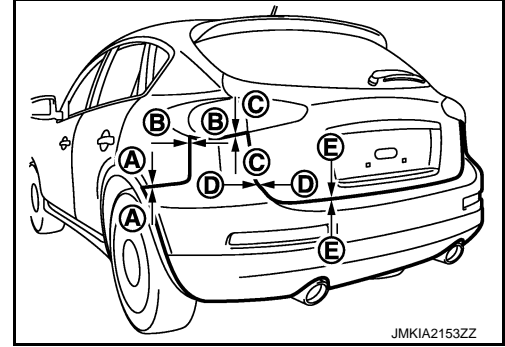

Portion		Clearance	Surface height difference
Rear bumper – Rear fender	A – A	0.0 – 0.8 mm (0.000 – 0.031 in)	- 0.2 – 1.8 mm (- 0.008 – 0.071 in)
Rear bumper – Rear fender	B – B	0.0 – 0.8 mm (0.000 – 0.031 in)	- 0.2 – 1.8 mm (- 0.008 – 0.071 in)
Rear bumper – Rear combination lamp	C – C	0.3 – 3.0 mm (0.012 – 0.118 in)	- 0.5 – 2.5 mm (- 0.020 – 0.098 in)
Rear bumper – Back door	D – D	2.9 – 7.1 mm (0.114 – 0.280 in)	- 1.7 – 2.5 mm (- 0.067 – 0.098 in)
Rear bumper – Back door	E – E	5.0 – 9.0 mm (0.197 – 0.354 in)	—

A
B
C
D
E
F
G
H
I
J
L
M
N
O
P

EXT

FRONT GRILLE

< REMOVAL AND INSTALLATION >

FRONT GRILLE

Exploded View

INFOID:000000006342840

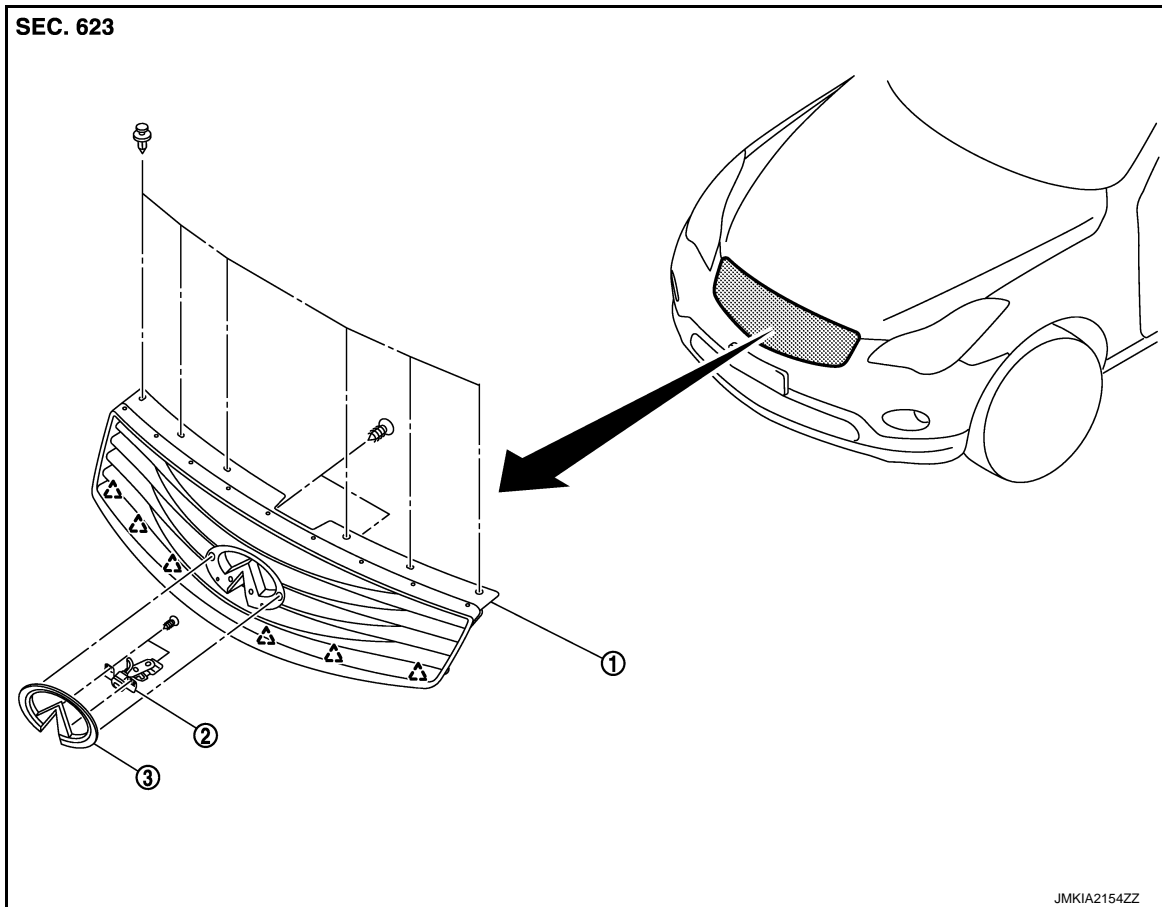

1. Front grille

2. Front camera

3. Front emblem

△ : Pawl

Removal and Installation

INFOID:000000006342841

REMOVAL

CAUTION:

Apply protection tape around outer circumference of front grille (bumper fascia side).

1. Fully open hood.
2. Remove front grille (1) fixing clips (A) with remover tool.

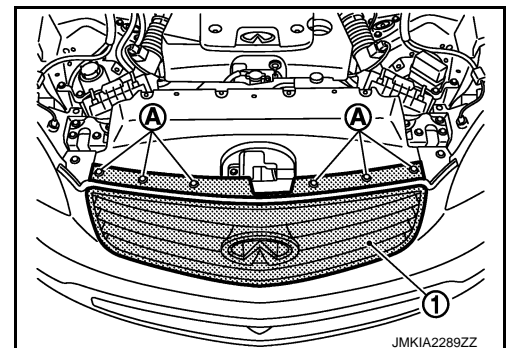

FRONT GRILLE

< REMOVAL AND INSTALLATION >

3. Remove hood seal assembly (front) (1) fixing clips with remover tool, and then remove hood seal assembly (front).

 : Clip

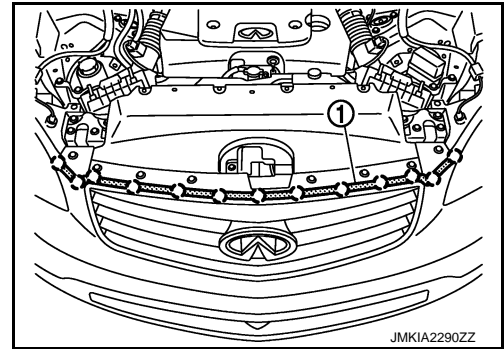

4. Pull front grille (1) horizontally toward vehicle front, and then remove front grille.

 : Pawl

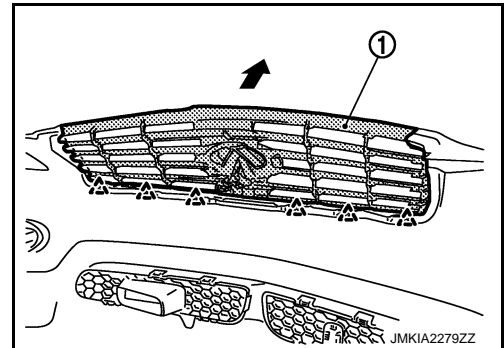

5. Remove front camera harness clips (A).
6. Disconnect front camera harness connector (B). (with FRONT CAMERA)

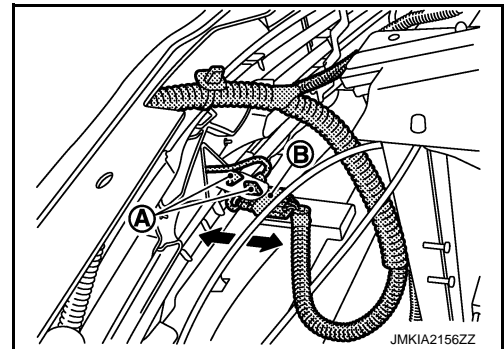

7. Remove the following parts after removing front grille.
• Front camera. (with FRONT CAMERA) Refer to [AV-531, "Removal and Installation"](#).
• Front emblem

INSTALLATION

Install in the reverse order of removal.

CAUTION:

Perform camera image calibration. Refer to [AV-425, "CALIBRATING CAMERA IMAGE \(AROUND VIEW MONITOR\) : Description"](#).

A
B
C
D
E
F
G
H
I
J
EXT
L
M
N
O
P

COWL TOP

< REMOVAL AND INSTALLATION >

COWL TOP

Exploded View

INFOID:00000006342842

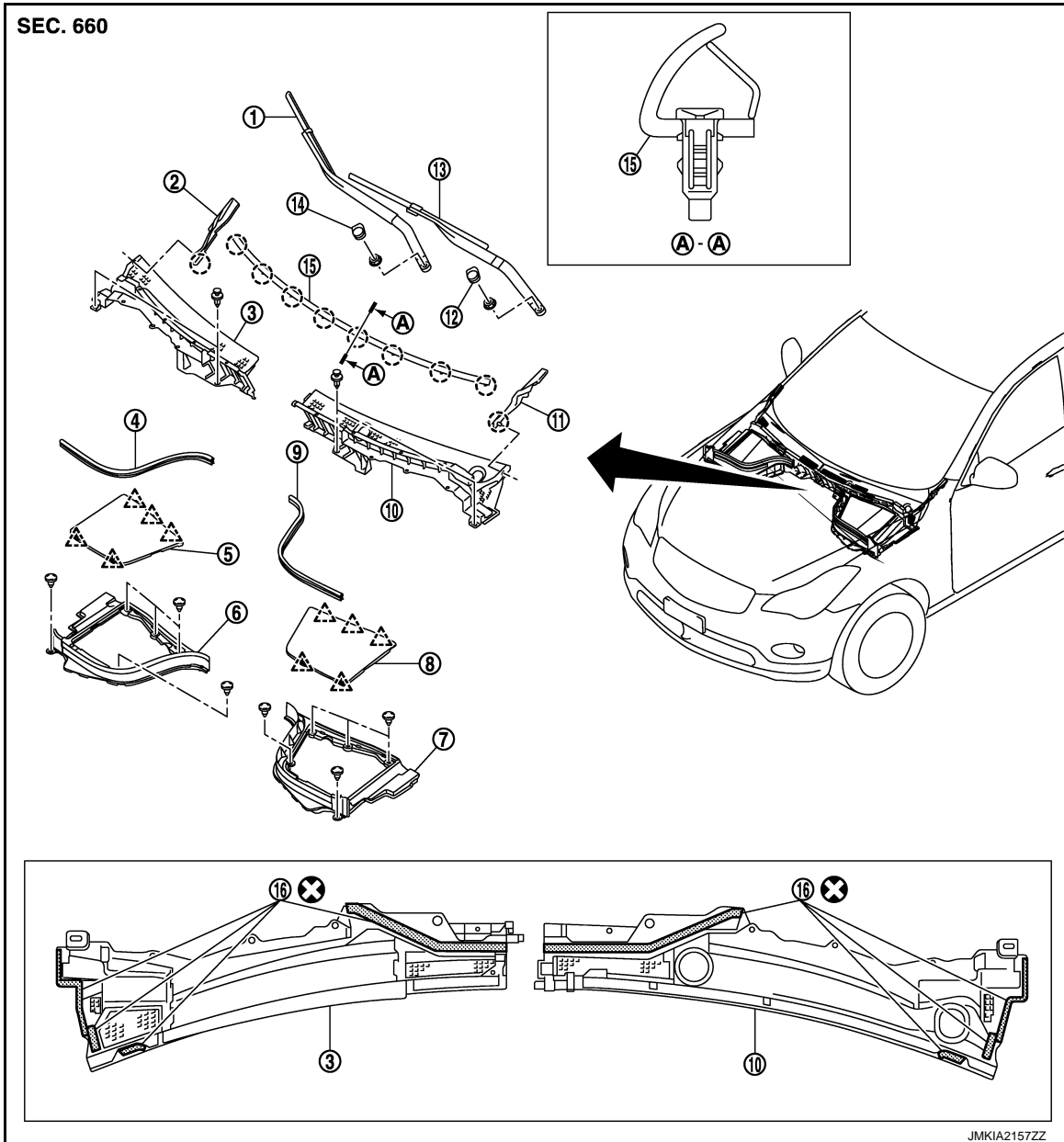

- | | | |
|--------------------------------|--------------------------------|------------------------------|
| 1. Front wiper arm & blade RH | 2. Front fender cover RH | 3. Cowl top cover RH |
| 4. Cowl top cover seal RH | 5. Battery cover | 6. Hoodledge cover RH |
| 7. Hoodledge cover LH | 8. Brake master cylinder cover | 9. Cowl top cover seal LH |
| 10. Cowl top cover LH | 11. Front fender cover LH | 12. Front wiper arm cover LH |
| 13. Front wiper arm & blade LH | 14. Front wiper arm cover RH | 15. Cowl top seal |
| 16. EPT sealer | | |

○ : Clip

△ : Pawl

Refer to [GI-4, "Components"](#) for symbols in the figure.

COWL TOP

< REMOVAL AND INSTALLATION >

Removal and Installation

INFOID:00000006342843

REMOVAL

1. Fully open hood assembly.
2. Remove front wiper arm (LH/RH) from vehicle. Refer to [WW-110, "Removal and Installation"](#).
3. Remove battery cover and brake master cylinder cover.
4. Remove cowl top cover seal (LH/RH).
5. Remove hoodledge cover mounting clips and then remove hoodledge cover (LH/RH).
6. Remove front fender cover (1) fixing clips (LH/RH).

 : Clip

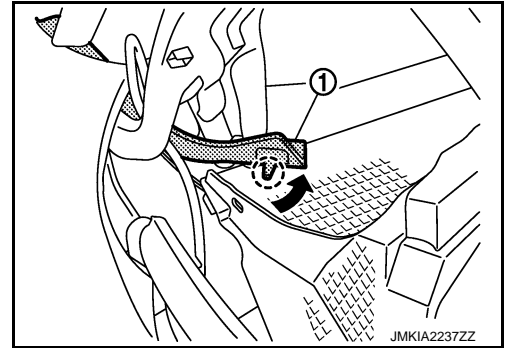

7. Remove cowl top seal fixing clips with remover tool, and then remove cowl top seal.
8. Remove cowl top cover fixing clips.
9. Pull up plastic pawl (A) to remove cowl top cover RH (1) as shown in the figure.

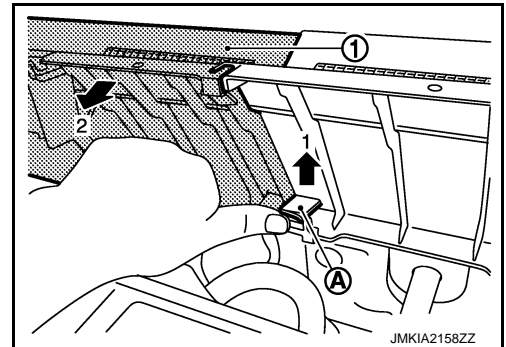

10. Push plastic pawl (A) as shown by the arrow in the figure to remove cowl top cover LH (1).

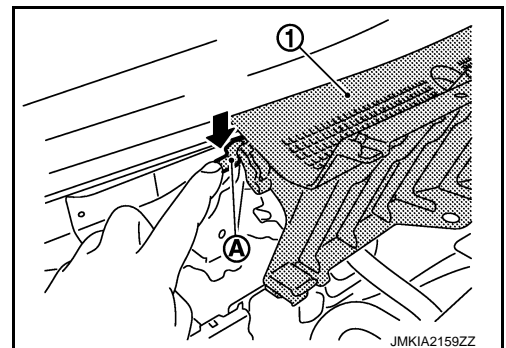

INSTALLATION

Note the following, and install in the reverse order of removal.

A
B
C
D
E
F
G
H
I
J
EXT
L
M
N
O
P

COWL TOP

< REMOVAL AND INSTALLATION >

- Install cowl top cover LH (1) with (A) [pin from front windshield glass(2)] aligned with concave part.

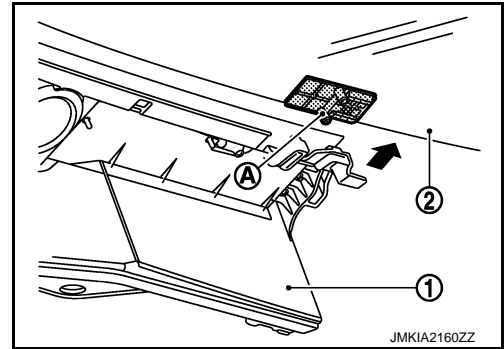

- Slide the pawl while aligning with the concave part of (C).
- Engage the joint of plastic pawl of (A) with (B), and then assemble cowl top covers LH (1) and RH (2).

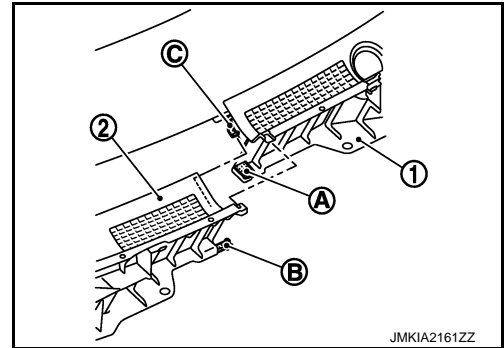

CAUTION:

- Always replace cowl top cover EPT sealer on rear of vehicle with a new one when installing old cowl top cover.
- After installing, perform adjustment of wiper arm. Refer to [WW-110. "Adjustment"](#).

FENDER PROTECTOR

< REMOVAL AND INSTALLATION >

FENDER PROTECTOR

FENDER PROTECTOR

FENDER PROTECTOR : Exploded View

INFOID:000000006342844

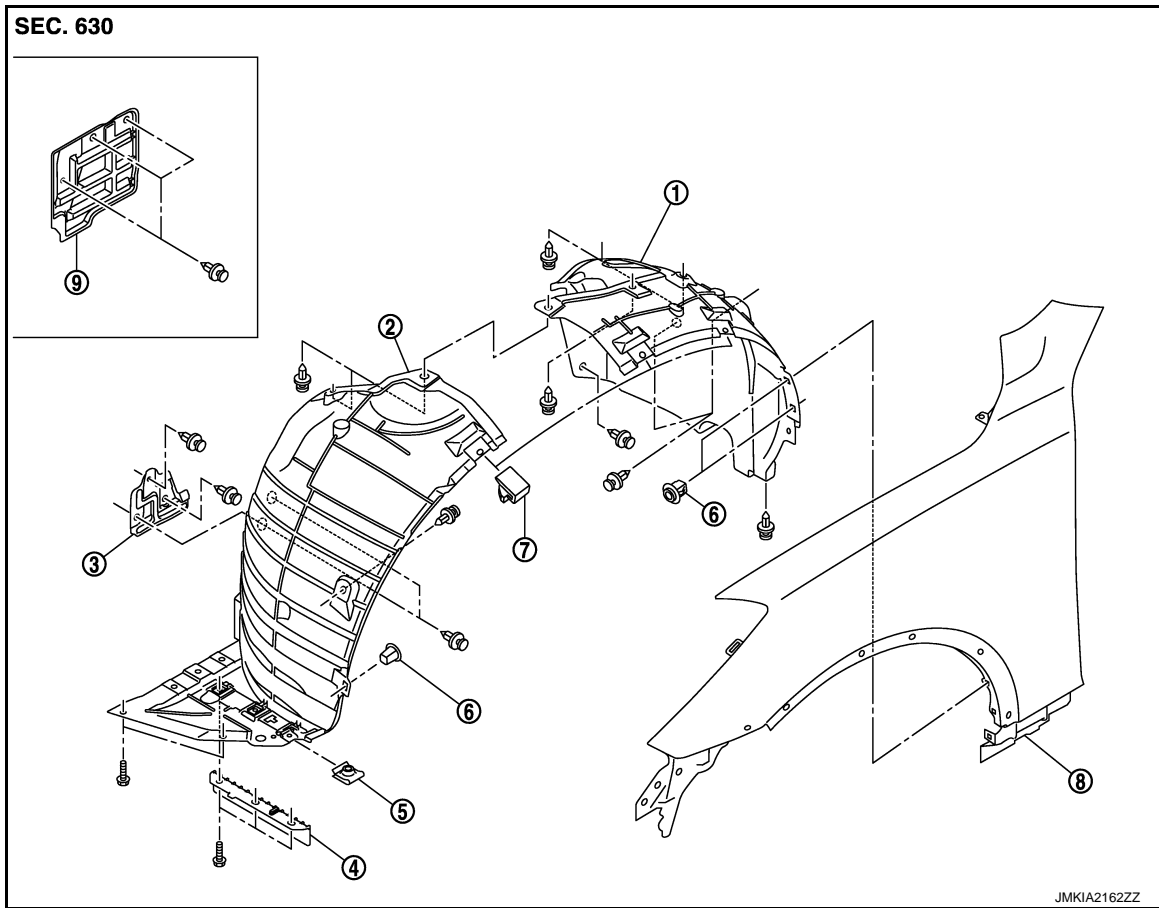

- | | | |
|----------------------------|-----------------------------|-----------------------|
| 1. Fender protector (rear) | 2. Fender protector (front) | 3. Splash guard |
| 4. Air guide | 5. J-nut | 6. Grommet |
| 7. Fender clip | 8. Front fender | 9. Splash guard (AWD) |

FENDER PROTECTOR : Removal and Installation

INFOID:000000006342845

REMOVAL

1. Remove front fillet molding. Refer to [EXT-32. "Removal and Installation"](#).
2. Remove front fender (rear) fixing grommets (A) with remover tool (B).

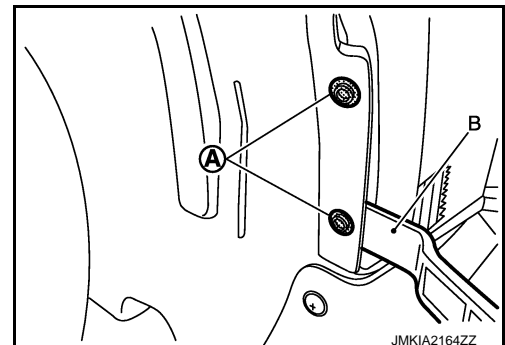

FENDER PROTECTOR

< REMOVAL AND INSTALLATION >

3. Remove center mudguard (1) fixing screws (A).
4. Remove center mudguard fixing bolt (B).

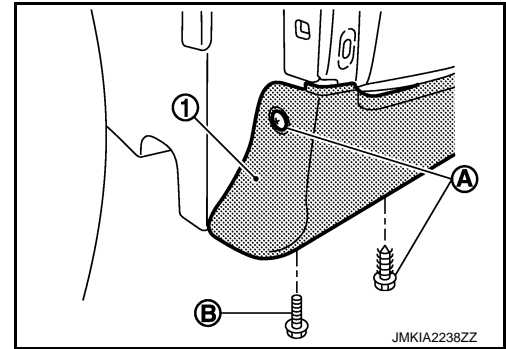

5. Remove clips of fender protector (rear).
6. Remove fender clip from wheel house arches, and then remove fender protector (rear) from wheel house.
7. Remove front fender (front) fixing grommet (A) with remover tool (B).

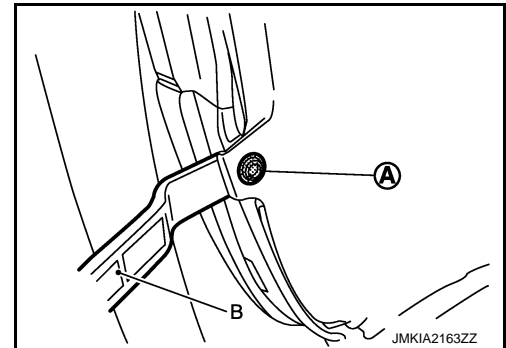

8. Remove fender protector (front) fixing bolts (A).

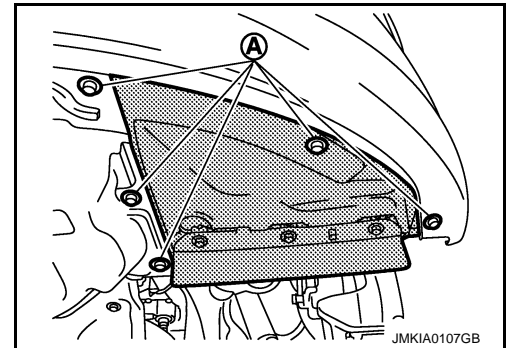

9. Remove fender protector (front) mounting clips.
10. Remove fender clip from wheel house arches, and then remove fender protector (front) from wheel house.
11. Remove the following parts after removing front fender protector.
 - Air guide
 - Fender clip

INSTALLATION

Install in the reverse order of removal.

REAR WHEEL HOUSE PROTECTOR

FENDER PROTECTOR

< REMOVAL AND INSTALLATION >

REAR WHEEL HOUSE PROTECTOR : Exploded View

INFOID:000000006342846

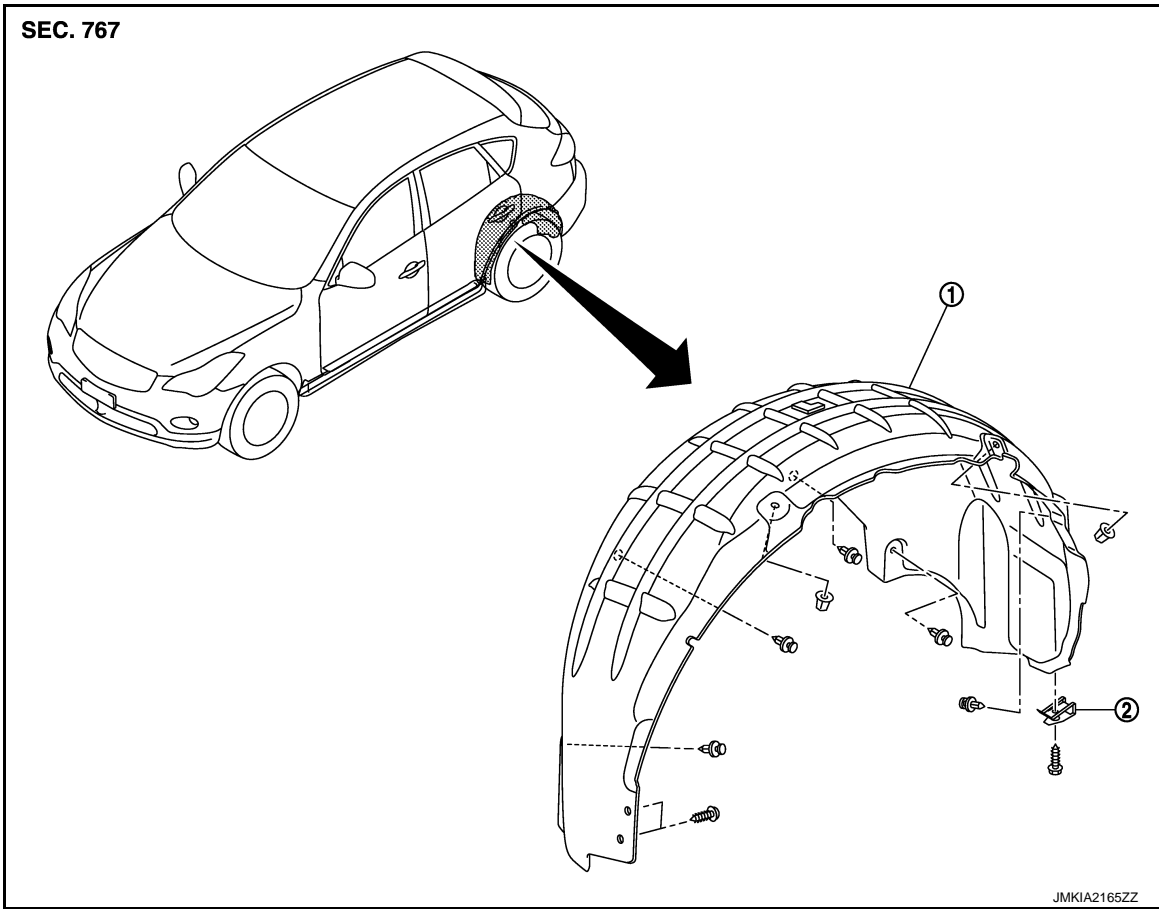

1. Rear wheel house protector 2. Spring nut

REAR WHEEL HOUSE PROTECTOR : Removal and Installation

INFOID:000000006342847

REMOVAL

1. Remove bolt (A) of rear wheel house protector rear end.

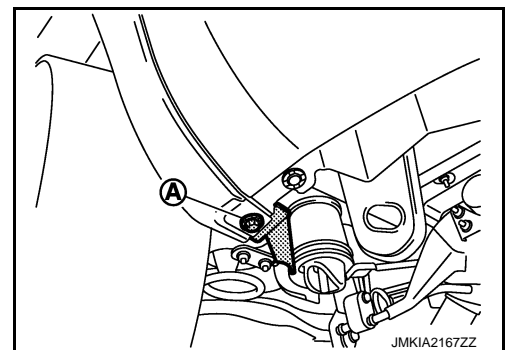

A
B
C
D
E
F
G
H
I
J

EXT

L
M
N
O
P

FENDER PROTECTOR

< REMOVAL AND INSTALLATION >

2. Remove screws (A) of rear wheel house protector located on center mud guard.

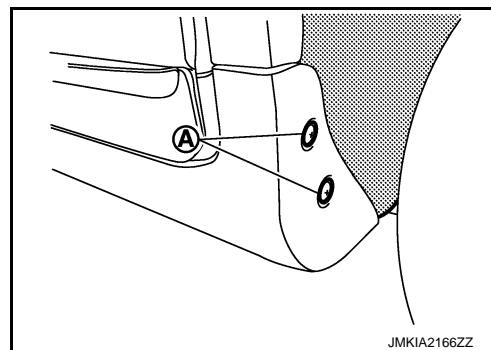

3. Remove rear wheel house protector fixing clips and nuts and then remove rear wheel house protector.

INSTALLATION

Install in the reverse order of removal.

CENTER MUD GUARD

< REMOVAL AND INSTALLATION >

CENTER MUD GUARD

Exploded View

INFOID:000000006342848

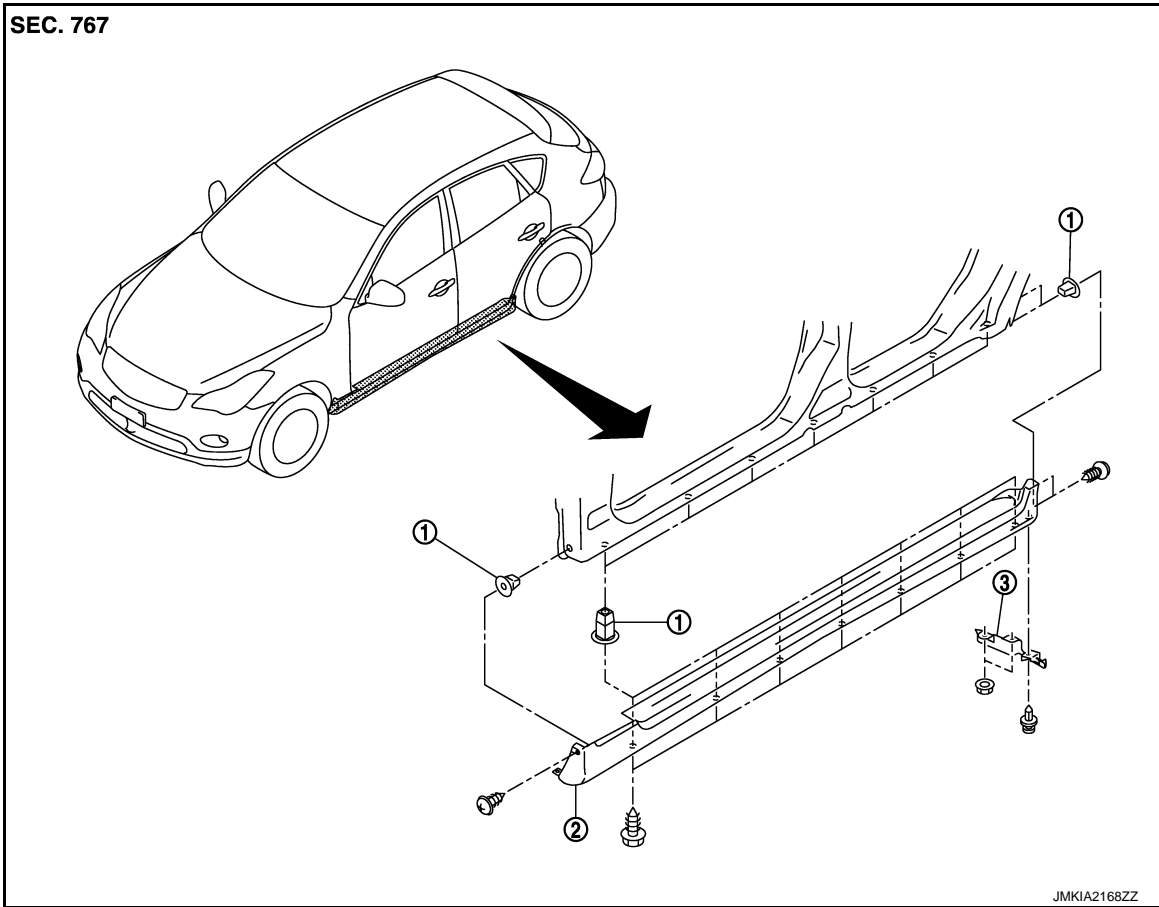

1. Grommet

2. Center mud guard

3. Wind deflector

EXT

Removal and Installation

INFOID:000000006342849

REMOVAL

1. Remove wind deflector (1) fixing clip (A) and nuts (B), then remove wind deflector.

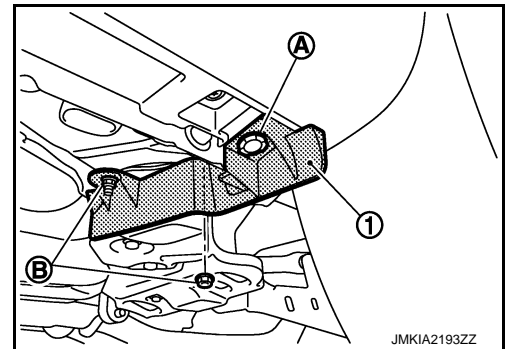

CENTER MUD GUARD

< REMOVAL AND INSTALLATION >

2. Remove screw (A) of center mud guard (1) front end.

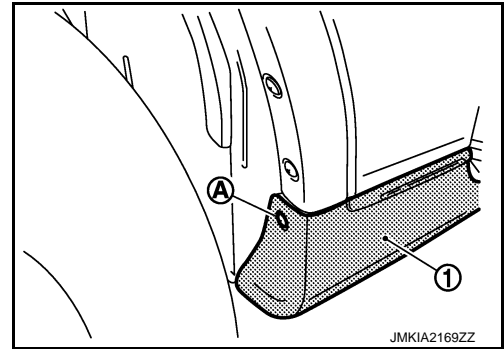

3. Remove screws (A) of center mud guard (1) rear end.

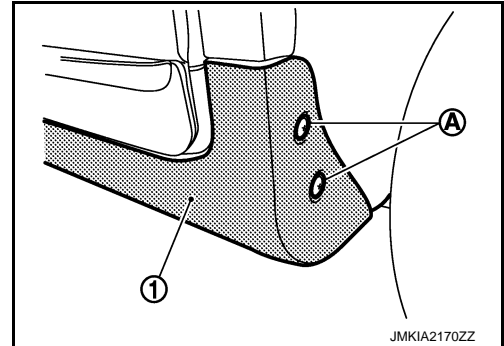

4. Remove bolt and screws of center mud guard underside.

5. Fully open front door and rear door.

6. Remove clips from back of center mud guard (1) using remover tool (A).

CAUTION:

Apply protective tape (B) around the center mud guard.

 : Clip

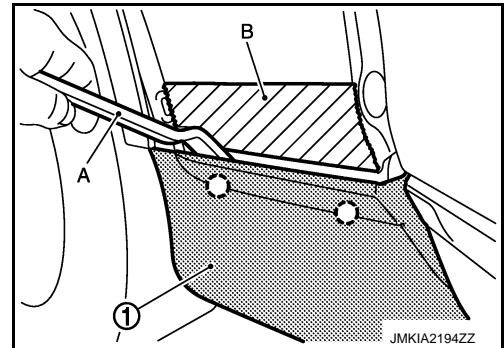

7. Remove center mud guard from body side.

INSTALLATION

Install in the reverse order of removal.

CAUTION:

When installing center mud guard, make sure that clips are securely fitted in panel holes on body, and then press them in.

FLOOR SIDE FAIRING

< REMOVAL AND INSTALLATION >

FLOOR SIDE FAIRING

Exploded View

INFOID:000000006342850

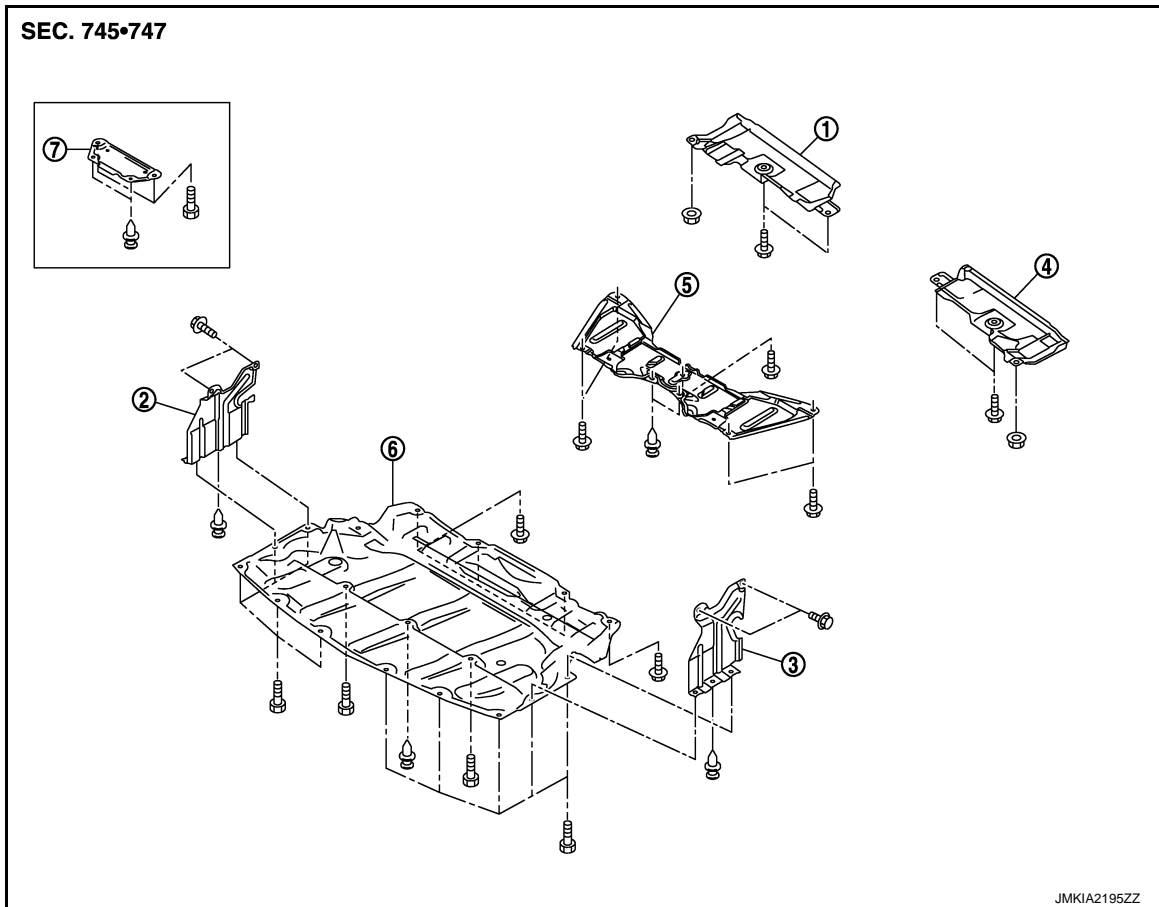

- | | | |
|-----------------------------------|-----------------------------------|------------------------------|
| 1. Floor under cover RH | 2. Front under side cover RH | 3. Front under side cover LH |
| 4. Floor under cover LH | 5. Front under cover (AWD models) | 6. Engine lower cover |
| 7. Front under cover (2WD models) | | |

Removal and Installation

INFOID:000000006342851

REMOVAL

ENGINE LOWER COVER

1. Remove engine lower cover fixing clip.
2. Remove engine lower cover fixing bolts with power tool.
3. Remove engine lower cover.

FRONT UNDER SIDE COVER (LH/RH)

1. Remove engine lower cover.
2. Remove front under side cover fixing clips.
3. Remove front under side cover.

FLOOR UNDER COVER (LH/RH)

1. Remove floor under cover fixing bolt and nuts with power tool.
2. Remove floor under cover.

INSTALLATION

Install in the reverse order of removal.

A
B
C
D
E
F
G
H
I
J

EXT

L
M
N
O
P

FILLET MOLDING

< REMOVAL AND INSTALLATION >

FILLET MOLDING

Exploded View

INFOID:000000006342852

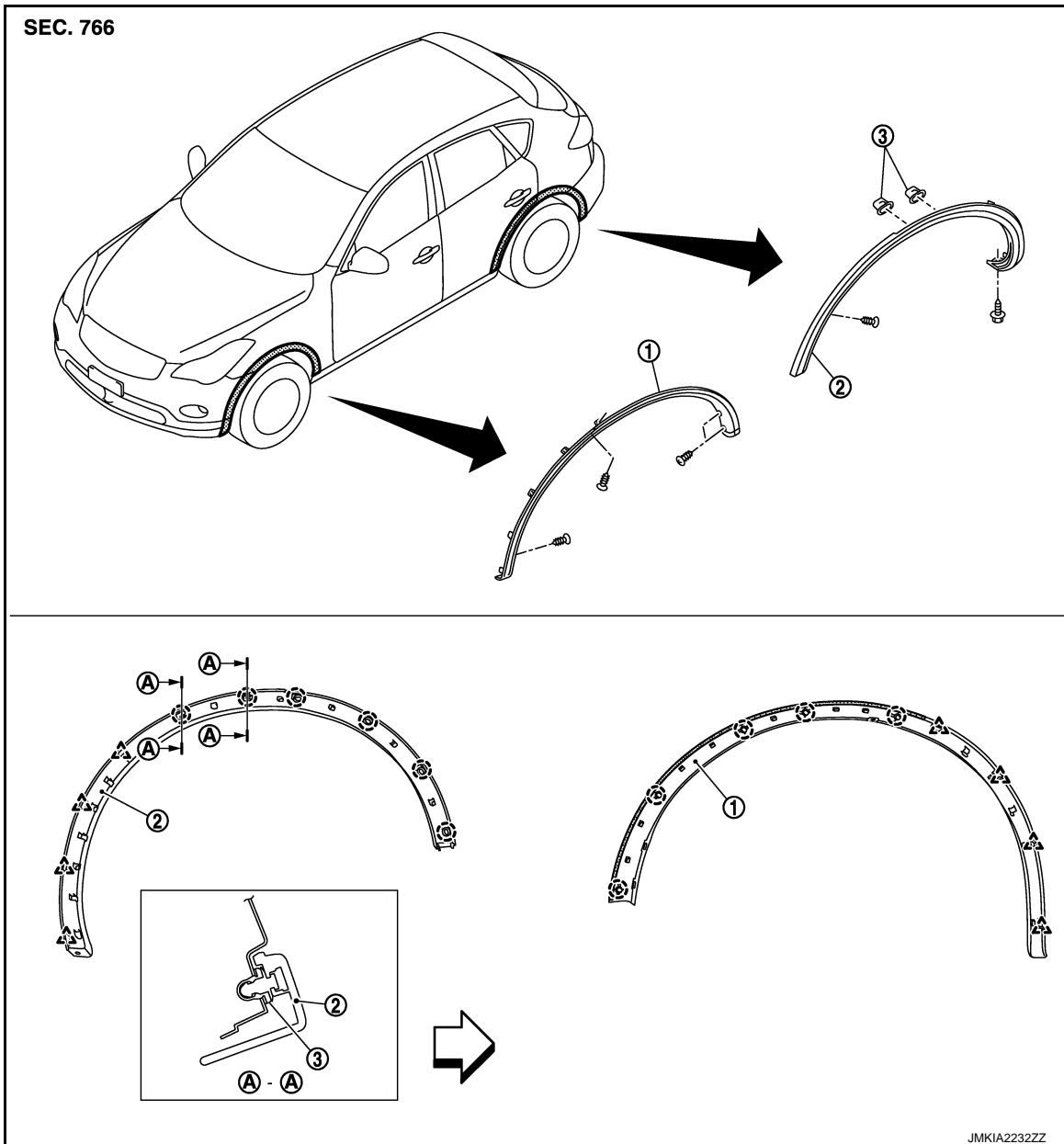

Removal and Installation

INFOID:000000006342853

REMOVAL

FRONT FILLET MOLDING

1. Remove front fillet molding fixing screws.

FILLET MOLDING

< REMOVAL AND INSTALLATION >

- Disengage the pawls from the front fillet molding (1) frontal part.

 : Pawl

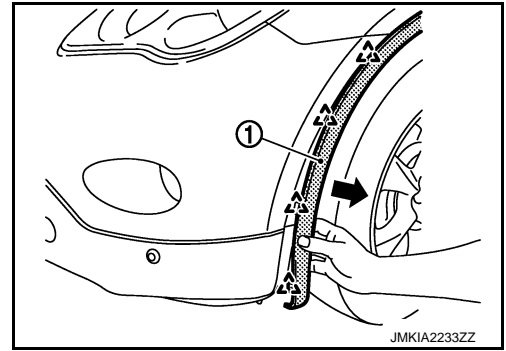

- Using a remover tool (A), disengage the clips from the front fillet molding (1) by starting from the front.

 : Clip

CAUTION:

- Apply a protective tape (B) on the body to protect the painted surface from damage.
- Disengage the clips slowly and carefully.
- Never pull the front fillet molding (1) strongly.

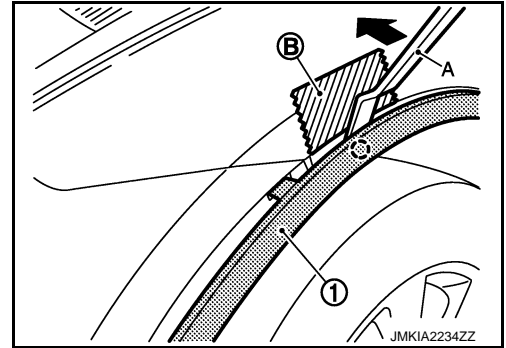

REAR FILLET MOLDING

- Remove rear mud guard fixing screws, and then remove rear mud guard.
- Remove rear fillet molding fixing screws.
- Disengage the pawls from the rear fillet molding (1) rear side.

 : Pawl

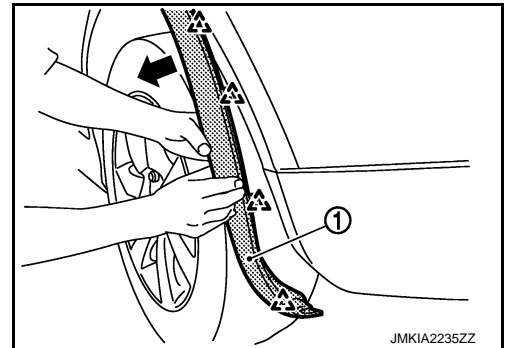

- Using a remover tool (A), disengage the clips from the rear fillet molding (1) by starting from the rear.

 : Clip

CAUTION:

- Apply a protective tape (B) on the body to protect the painted surface from damage.
- Disengage the clips slowly and carefully.
- Never pull the rear fillet molding (1) strongly.

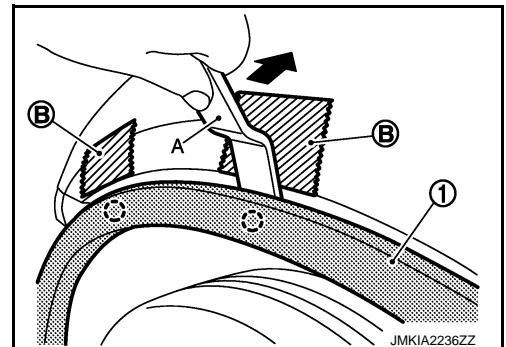

INSTALLATION

Install in the reverse order of removal.

CAUTION:

- When installing, check visually the fillet molding and the clips, then replace them with new parts if they have been damaged.
- When installing fillet molding, check that blind clips are securely fitted in panel holes on body, and then press them in.

A
B
C
D
E
F
G
H
I
J
EXT
L
M
N
O
P

ROOF RAIL

< REMOVAL AND INSTALLATION >

ROOF RAIL

Exploded View

INFOID:000000006342854

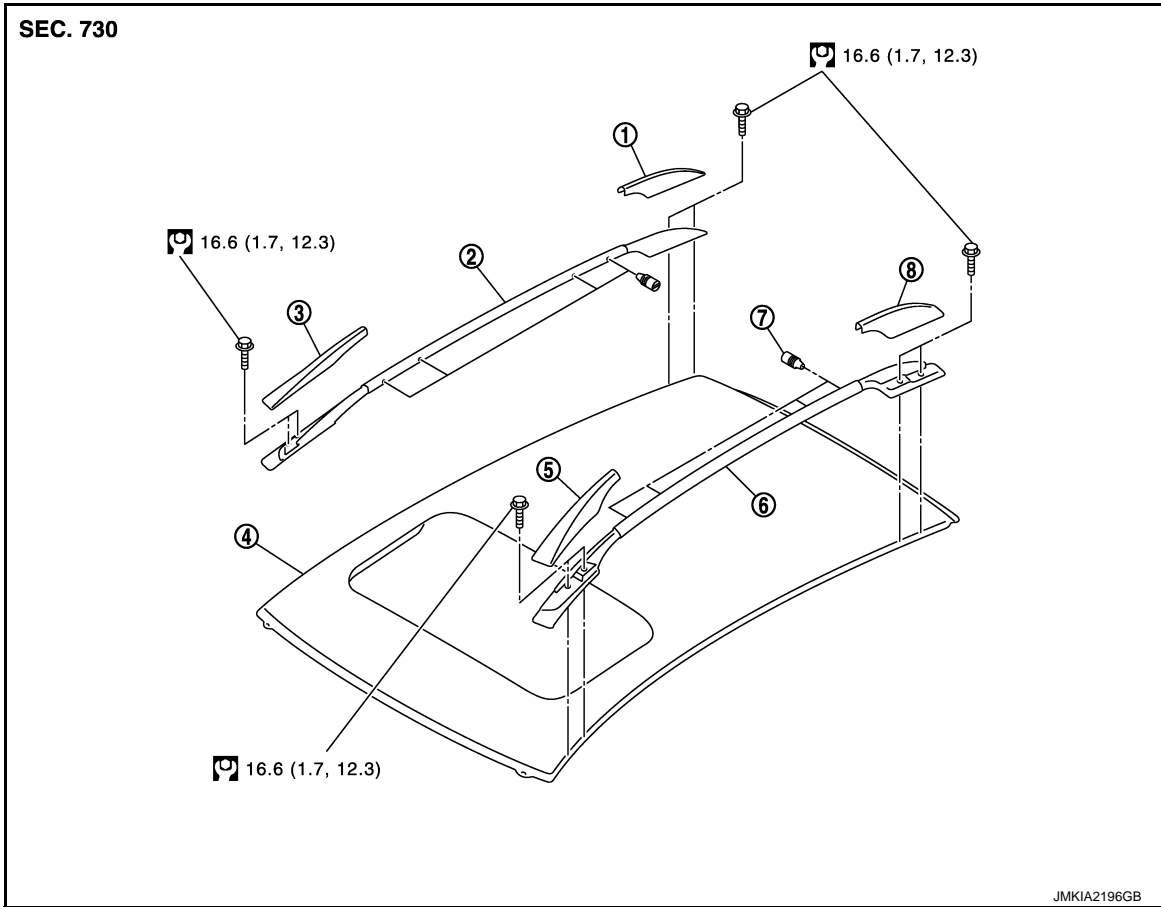

- | | | |
|----------------------------|-----------------------------|-----------------------------|
| 1. Rear roof rail cover RH | 2. Roof rail assembly RH | 3. Front roof rail cover RH |
| 4. Roof panel | 5. Front roof rail cover LH | 6. Roof rail assembly LH |
| 7. Roof rack cap | 8. Rear roof rail cover LH | |

Refer to [GI-4, "Components"](#) of symbols in the figure.

Removal and Installation

INFOID:000000006342855

REMOVAL

1. Insert a remover tool (A) into front space.
2. Remove front roof rail cover (1) outside pawls with remover tool (B).

CAUTION:

Apply protective tape (C) around the roof rail.

 : Pawl

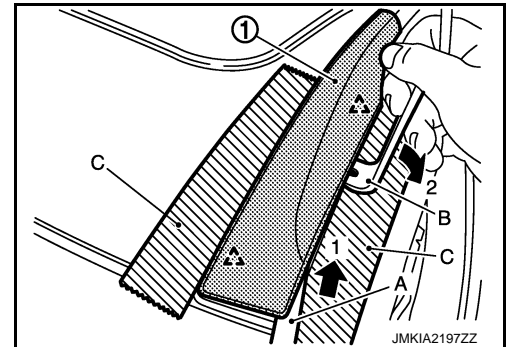

ROOF RAIL

< REMOVAL AND INSTALLATION >

3. Insert a remover tool (A) into outside space.
4. Remove front roof rail cover (1) inside pawls with remover tool (B).

 : Pawl

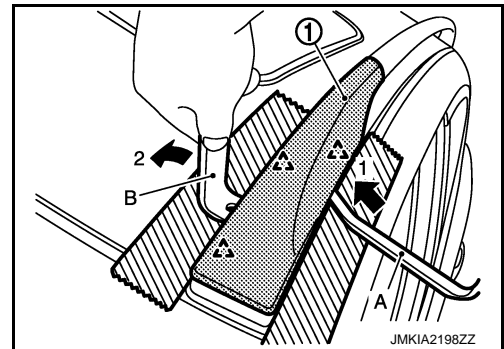

5. Pull front roof rail cover (1) toward the arrow direction.

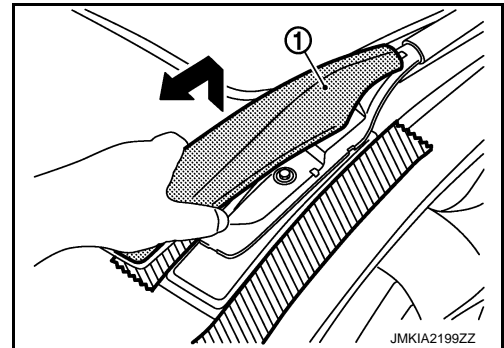

6. Insert a remover tool (A) into rear space.
7. Remove rear roof rail cover (1) outside pawls with remover tool (B).

CAUTION:

Apply protective tape (C) around the roof rail.

 : Pawl

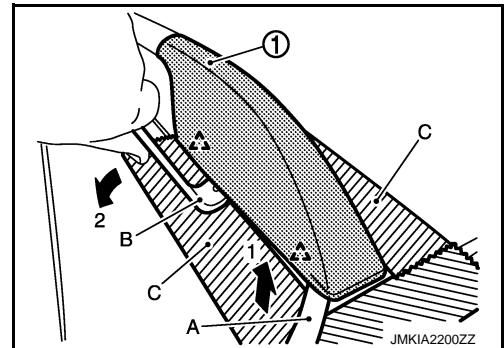

8. Insert a remover tool (A) into outside space.
9. Remove rear roof rail cover (1) inside pawls with remover tool (B).

 : Pawl

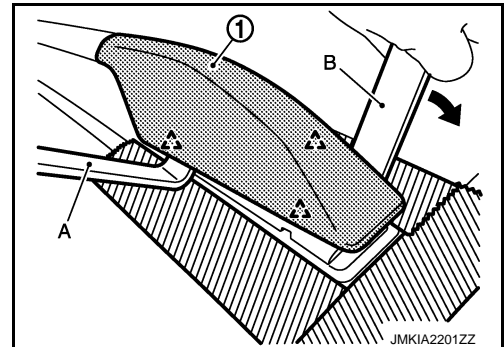

10. Pull rear roof rail cover (1) toward the arrow direction.

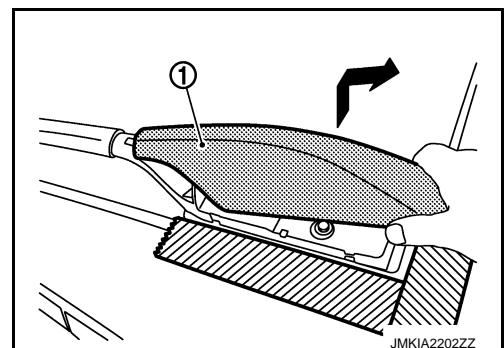

A
B
C
D
E
F
G
H
I
J
EXT
L
M
N
O
P

ROOF RAIL

< REMOVAL AND INSTALLATION >

11. Remove roof rail assembly mounting bolts, and then remove roof rail assembly.

INSTALLATION

Install in the reverse order of removal.

ROOF SIDE MOLDING

< REMOVAL AND INSTALLATION >

ROOF SIDE MOLDING

Exploded View

INFOID:000000006342856

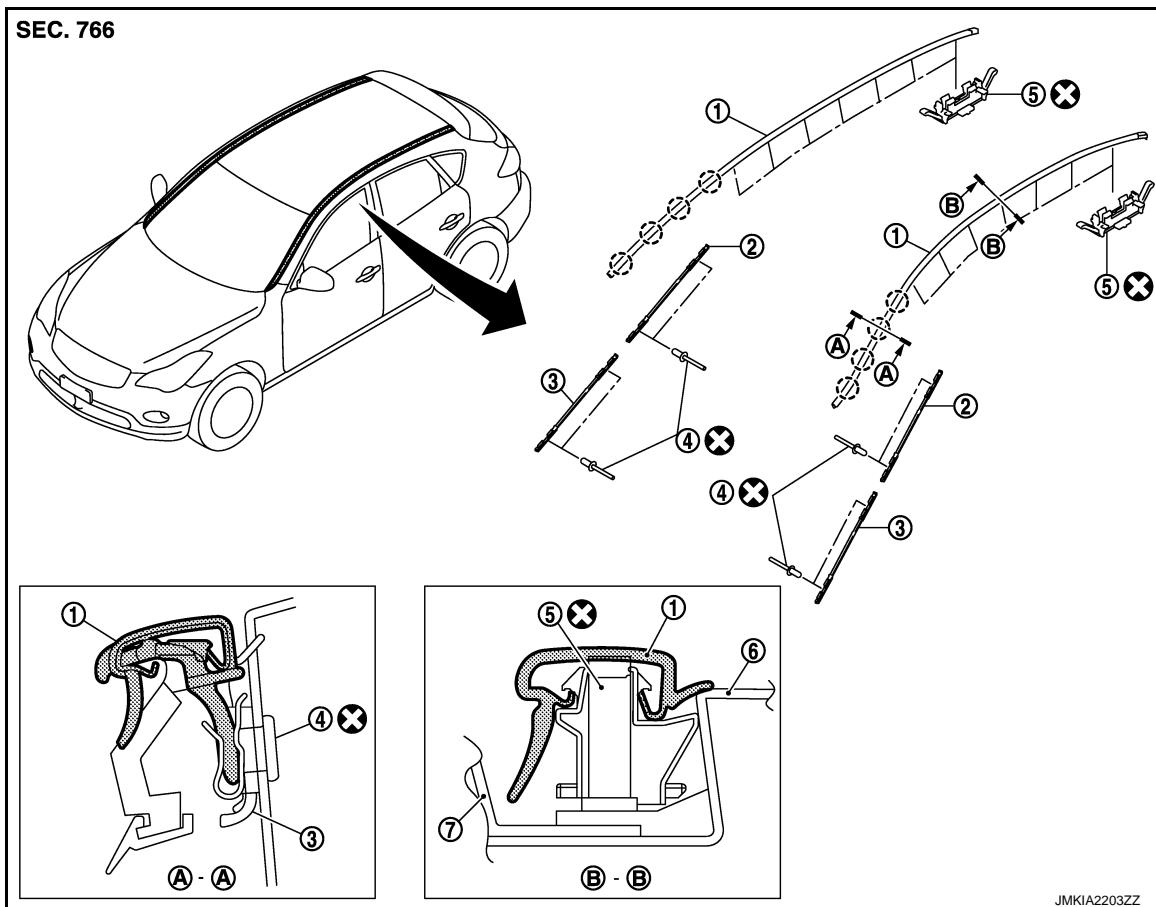

- | | | |
|----------------------|-----------------------------|-----------------------------|
| 1. Roof side molding | 2. Molding fastener (upper) | 3. Molding fastener (lower) |
| 4. Rivet | 5. Roof side molding clip | 6. Body side panel |
| 7. Roof panel | | |

○ : Clip

Refer to [GI-4, "Components"](#) for symbols in the figure.

Removal and Installation

INFOID:000000006342857

REMOVAL

1. Remove front fender cover (LH/RH). Refer to [EXT-22, "Exploded View"](#).
2. Disengage clips while pinching molding from roof rear end to front end.

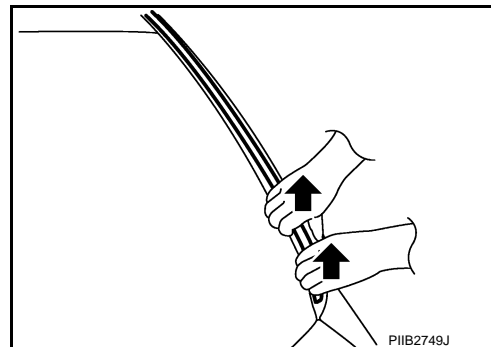

INSTALLATION

A
B
C
D
E
F
G
H
I
J

EXT

L
M
N
O
P

ROOF SIDE MOLDING

< REMOVAL AND INSTALLATION >

Install from roof side molding rear end to front end in this order after temporarily holding.

REMOVAL AND INSTALLATION OF ROOF SIDE MOLDING CLIP

Removal

1. Remove roof side molding.
2. Heat adhesive tape interface using a dryer, and then peel roof side molding clips (body side) using long-nose pliers.

CAUTION:

Be careful not to damage the body.

Installation

1. Clean tape removed surface with a shop cloth soaked in white gasoline or IPA.
2. Use two-part epoxy adhesive.

Adhesive : 3M-weld DP-100 or equivalent

3. Apply adhesive evenly to clip tape surface.

Thickness : Approximately 0.5 mm (0.020 in)

4. Position applied parts to the proper location, and then sufficiently press-fit until the adhesive protrudes to tape side.

Press-fit limit : 19.6 N (2.0 Kg - 4.41 lb) × 2 seconds

5. Tape clips after press fit, and temporarily hold it for specified time based on the following.

5 to 10 °C (41 to 50 °F) : 1 hour or more

11 to 23 °C (52 to 73 °F) : 30 minutes or more

24 °C or more (75 °F or more) : 15 minutes or more

6. Install from roof side molding rear end to front end in this order after temporarily holding.

CAUTION:

- Use double-faced adhesive tape after hardening for clips.
- Securely insert molding rear end cap onto roof rear end cutout (installation standard).
- When installing roof side molding of windshield portion, check that molding fastener is securely inserted and then press in.
- Never wash the vehicle with in 24 hours so as to keep adhesive.

DOOR SASH MOLDING

< REMOVAL AND INSTALLATION >

DOOR SASH MOLDING

Exploded View

INFOID:000000006342858

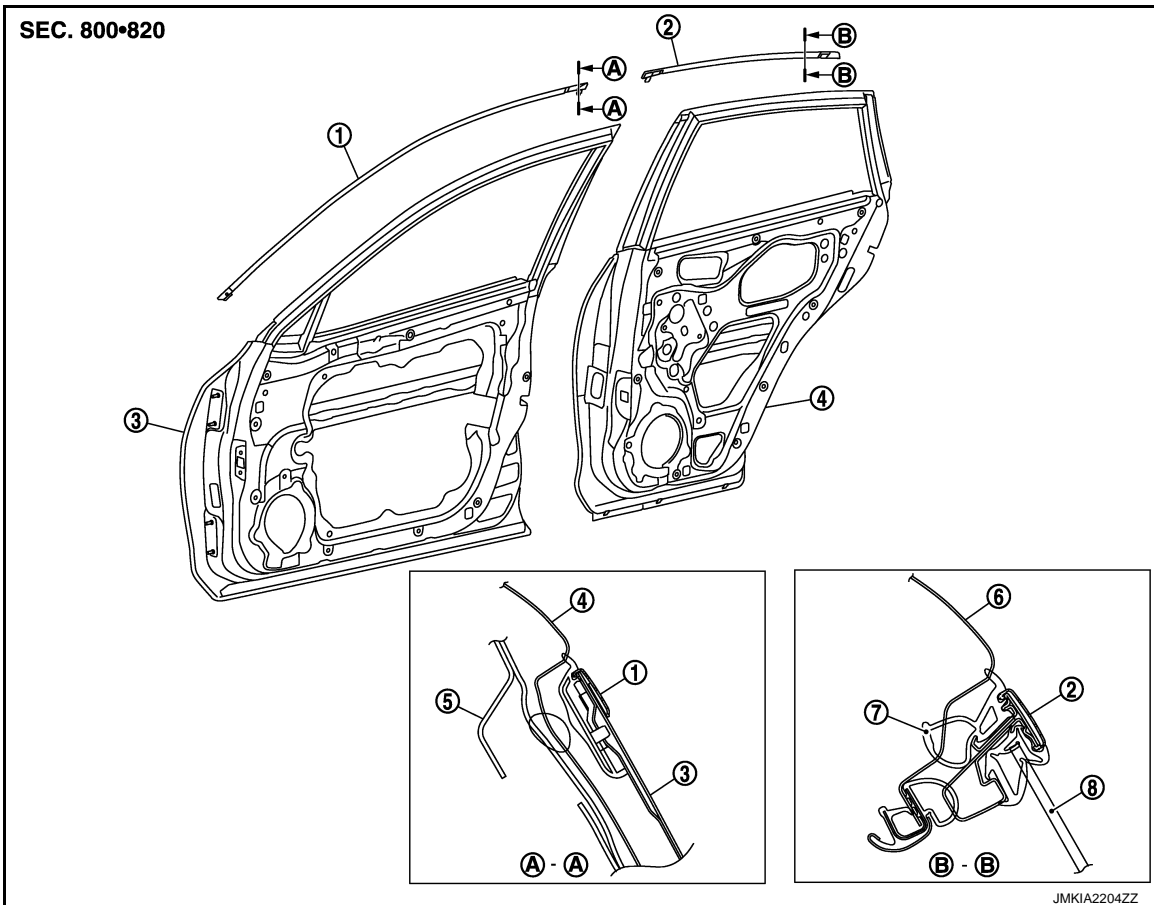

- | | | |
|----------------------------|---------------------------|---------------------|
| 1. Front door sash molding | 2. Rear door sash molding | 3. Front door panel |
| 4. Rear door panel | 5. Roof rail side outer | 6. Body side outer |
| 7. Rear door weather strip | 8. Rear door glass | |

Removal and Installation

INFOID:000000006342859

REMOVAL

FRONT DOOR SASH MOLDING

1. Remove door mirror assembly. Refer to [MIR-116. "DOOR MIRROR ASSEMBLY : Removal and Installation"](#).
2. Remove front door weather strip.
3. Release roof portion of glass run.
4. Remove front door sash molding (1) connection between door panel and molding from glass run side, using a remover tool (A).

CAUTION:

Never use a material for remover tool (A) which could damage door panel.

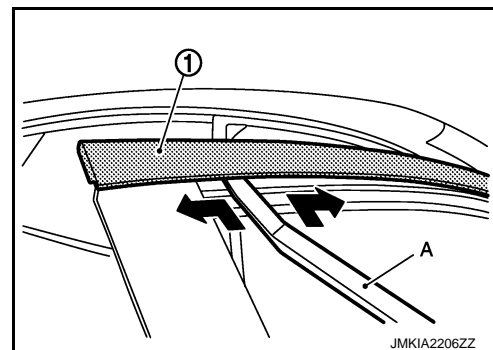

DOOR SASH MOLDING

< REMOVAL AND INSTALLATION >

5. Remove front door sash molding.

REAR DOOR SASH MOLDING

1. Remove rear door weather-strip.
2. Release roof portion of glass run.
3. Remove rear door sash molding (1) connection between door panel and molding from glass run side, using a remover tool (A).

CAUTION:

- Apply protection tape (B) around the door sash.
- Never use a material for remover tool (A) which could damage door panel.

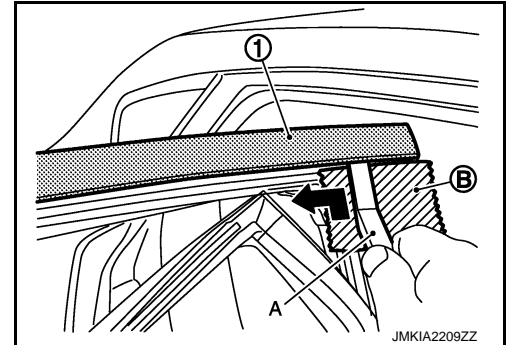

4. Remove rear door sash molding.

INSTALLATION

Install in the reverse order of removal.

DOOR OUTSIDE MOLDING

< REMOVAL AND INSTALLATION >

DOOR OUTSIDE MOLDING

Exploded View

INFOID:000000006342860

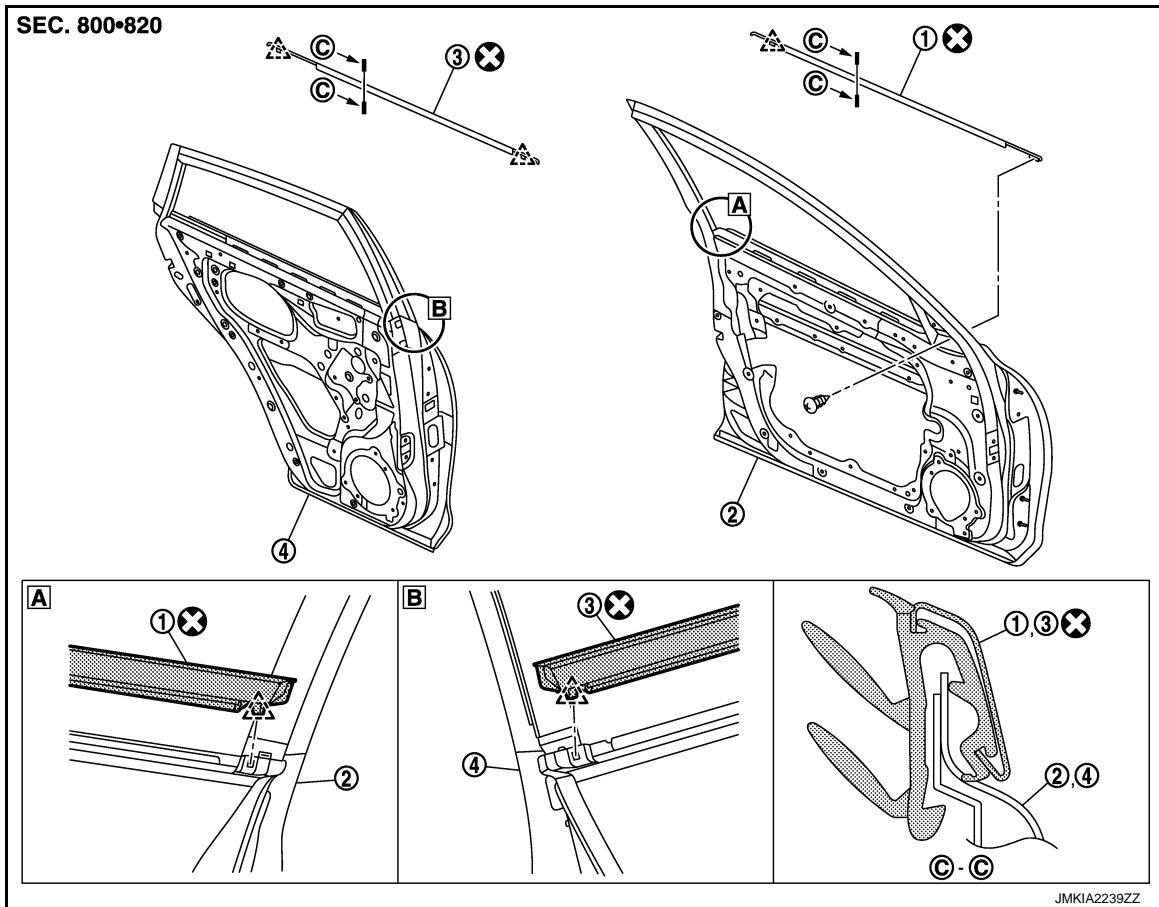

1. Front door outside molding 2. Front door panel 3. Rear door outside molding

4. Rear door panel

 : Pawl

Refer to [GI-4. "Components"](#) for symbols in the figure.

Removal and Installation

INFOID:000000006342861

REMOVAL

FRONT DOOR OUTSIDE MOLDING

1. Remove front door finisher.
 - Driver side: Refer to [INT-12. "DRIVER SIDE : Removal and Installation"](#).
 - Passenger side: Refer to [INT-15. "PASSENGER SIDE : Removal and Installation"](#).
2. Remove door mirror assembly. Refer to [MIR-116. "DOOR MIRROR ASSEMBLY : Removal and Installation"](#).

A
B
C
D
E
F
G
H
I
J
EXT
L
M
N
O
P

DOOR OUTSIDE MOLDING

< REMOVAL AND INSTALLATION >

3. Remove front door outside molding (1) fixing screw (A).

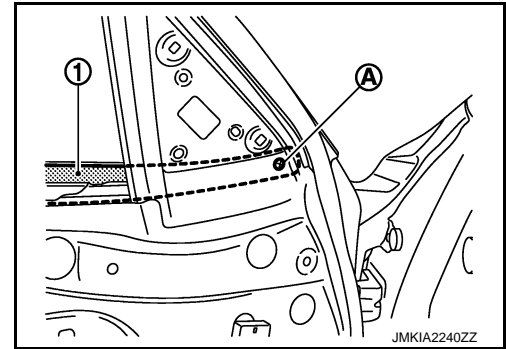

4. Insert a remover tool (A) into lower space.
5. Disengage pawls of fixing front door outside molding (1) with flat blade screw driver (B).

 : Pawl

CAUTION:

Apply protection tape (C) around outer circumference of front door.

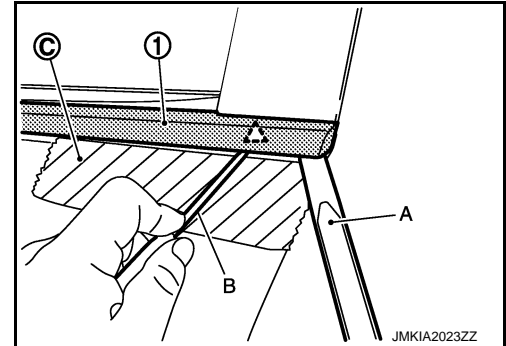

6. Twist and pull up to upper side, and then remove front door outside molding (1).

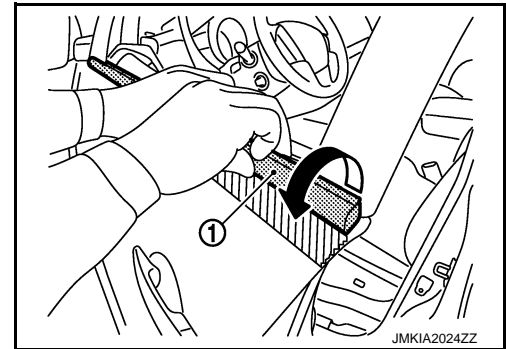

REAR DOOR OUTSIDE MOLDING

1. Fully open door window.
2. Insert a remover tool (A) into lower space.
3. Disengage pawls of fixing rear door outside molding (1) with flat blade screw driver (B).

 : Pawl

CAUTION:

Apply protection tape (C) around outer circumference of rear door.

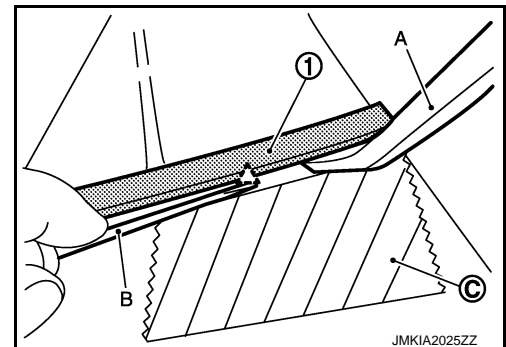

DOOR OUTSIDE MOLDING

< REMOVAL AND INSTALLATION >

4. Twist and pull up to upper side, and then remove rear door outside molding (1).

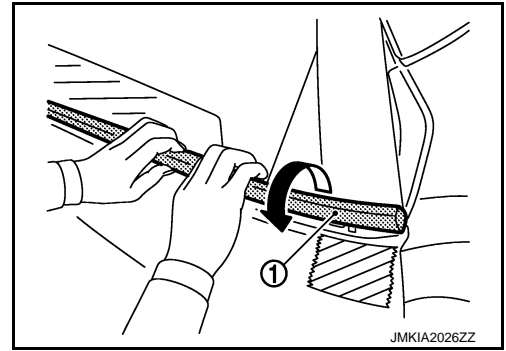

INSTALLATION

Install in the reverse order of removal.

A
B
C
D
E
F
G
H
I
J
L
M
N
O
P

EXT

DOOR OUTSIDE LOWER MOLDING

< REMOVAL AND INSTALLATION >

DOOR OUTSIDE LOWER MOLDING

Exploded View

INFOID:000000006342862

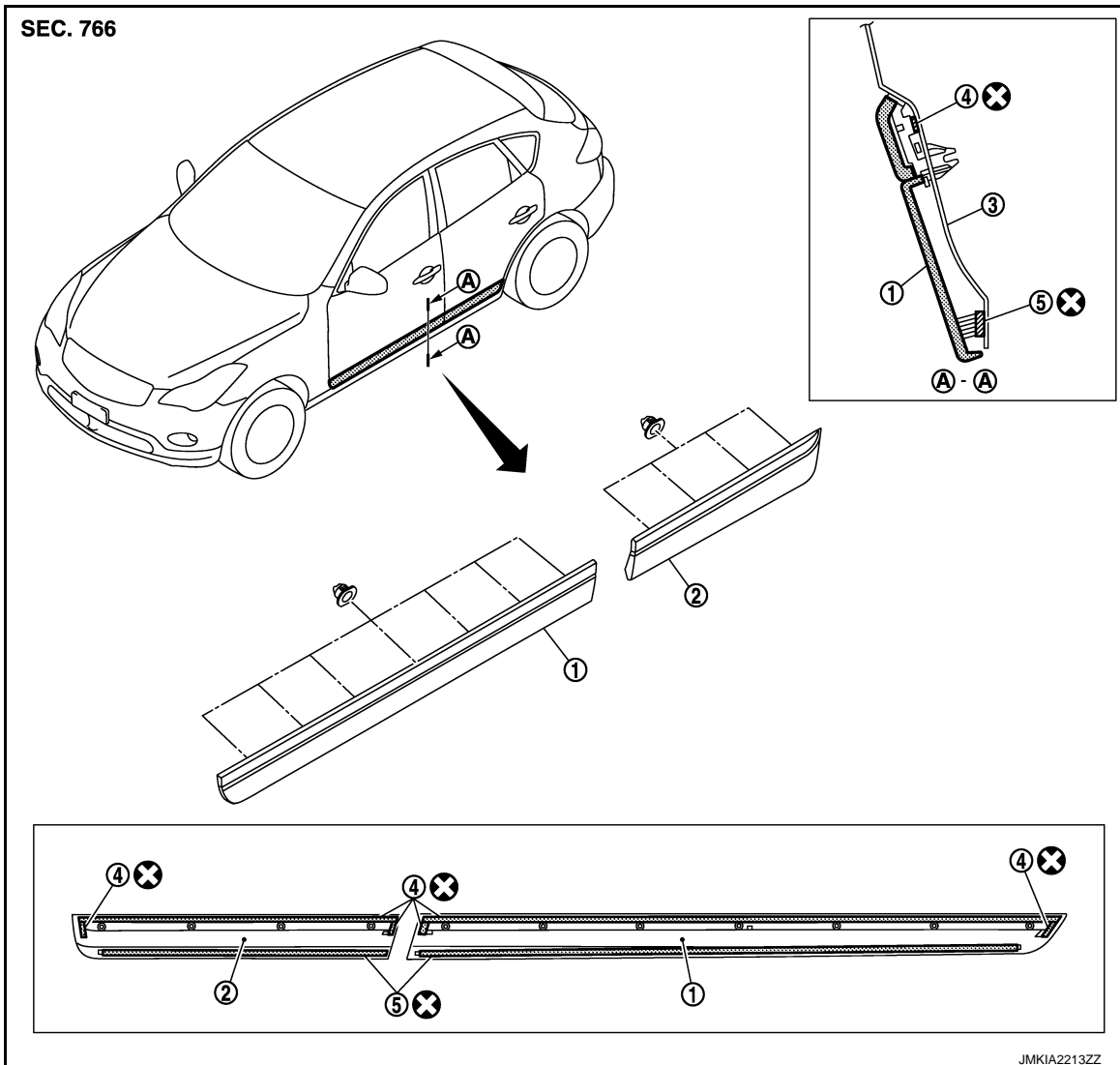

1. Front door outside lower molding
2. Rear door outside lower molding
3. Front door panel
4. Double-faced adhesive tape [t: 1.2 mm(0.047 in)]
5. Double-faced adhesive tape [t: 2.5 mm(0.098 in)]

Refer to [GI-4. "Components"](#) for symbols in the figure.

Removal and Installation

INFOID:000000006342863

REMOVAL

FRONT DOOR OUTSIDE LOWER MOLDING

DOOR OUTSIDE LOWER MOLDING

< REMOVAL AND INSTALLATION >

1. Remove double-faced adhesive tapes with remover tool (A).
2. Using a remover tool, disengage the clips from the front door outside lower molding (1) by starting from the rear.

CAUTION:

- Apply a protective tape (B) on the door to protect the painted surface from damage.
- Disengage the clips slowly and carefully.
- Never pull the front door outside lower molding.

 : Clip

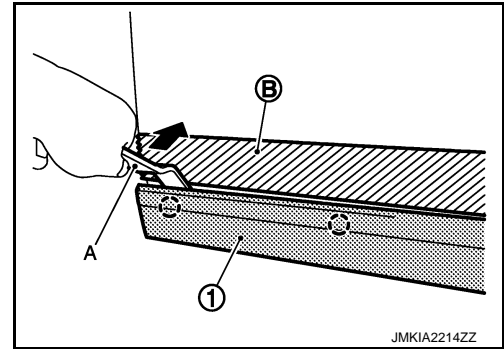

3. Remove front door outside lower molding.

REAR DOOR OUTSIDE LOWER MOLDING

1. Remove double-faced adhesive tapes with remover tool (A).
2. Using a remover tool, disengage the clips from the rear door outside lower molding (1) by starting from the rear.

CAUTION:

- Apply a protective tape (B) on the door to protect the painted surface from damage.
- Disengage the clips slowly and carefully.
- Never pull the front door outside lower molding.

 : Clip

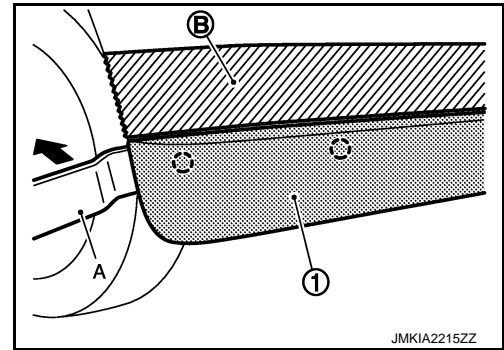

3. Remove rear door outside lower molding.

INSTALLATION

Install in the reverse order of removal.

CAUTION:

- Replace double-faced adhesive tape on back of molding with a new tape if door outside lower molding is reused.
- Never let air between contact surfaces when installing.
- When installing, check visually the door outside lower molding and the clips, then replace them with new parts if they have been damaged.
- When installing door outside lower molding, check that clips are securely fitted in panel holes on body, and then press them in.
- To secure contact, do not wash vehicle within 24 hours after installation.

A
B
C
D
E
F
G
H
I
J
EXT
L
M
N
O
P

DOOR PARTING SEAL

< REMOVAL AND INSTALLATION >

DOOR PARTING SEAL

Exploded View

INFOID:000000006342864

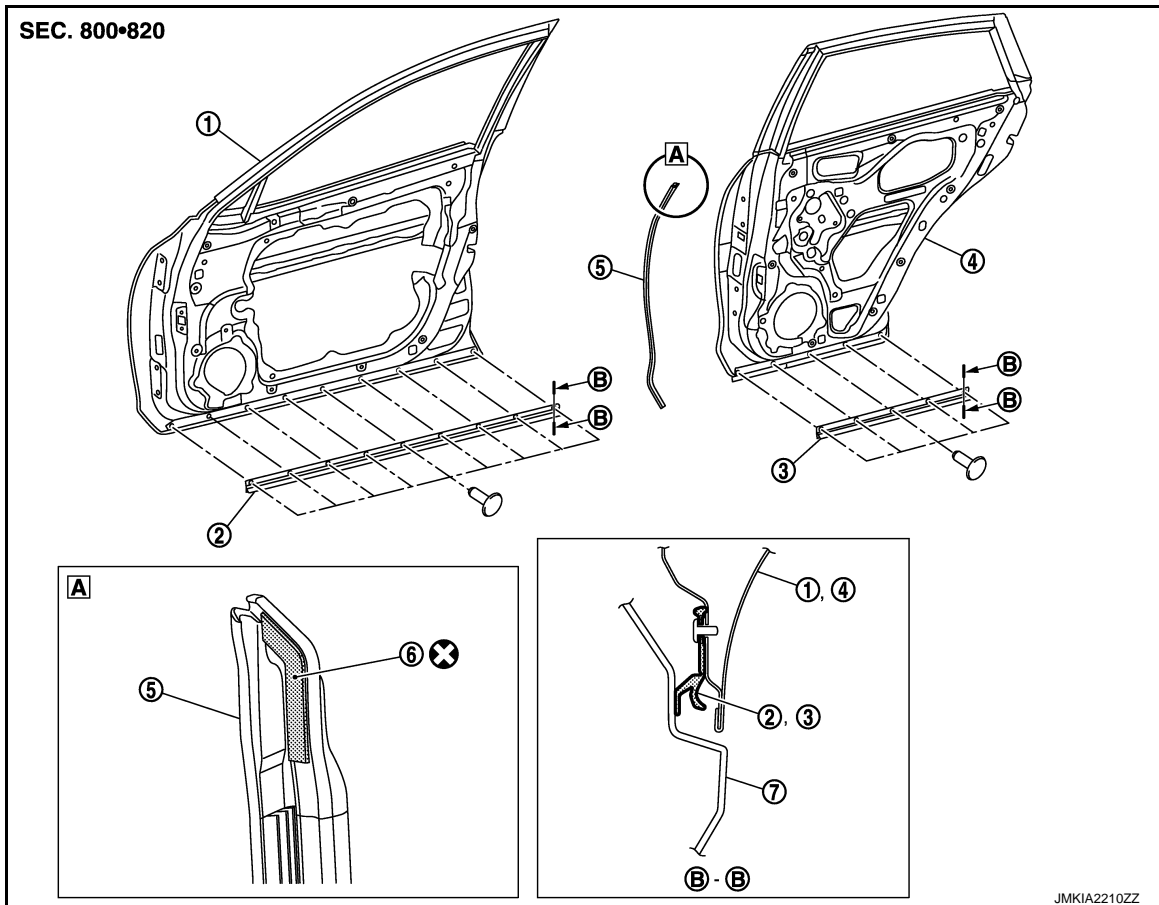

- | | | |
|---------------------|-----------------------------------|---|
| 1. Front door panel | 2. Front door parting sea | 3. Rear door parting seal (lower) |
| 4. Rear door panel | 5. Rear door parting seal (front) | 6. Double-faced adhesive tape
[t: 1.2 mm (0.047 in)] |
| 7. Center mud guard | | |

Refer to [GI-4. "Components"](#) of symbols in the figure.

Removal and Installation

INFOID:000000006342865

REMOVAL

FRONT DOOR PARTING SEAL

1. Fully open front door.
2. Using a remover tool (A), disengage the clips from the front door parting seal (1).

○ : Clip

CAUTION:

- Disengage the clips slowly and carefully.
- Never pull the front door parting seal strongly.

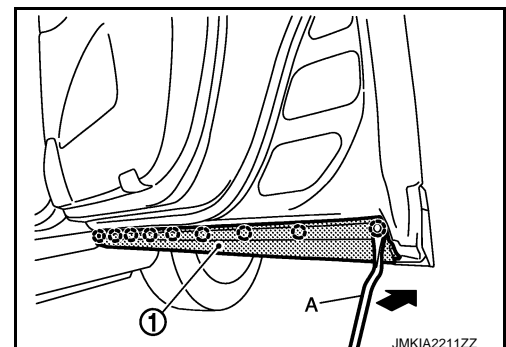

JMKIA2211ZZ

DOOR PARTING SEAL

< REMOVAL AND INSTALLATION >

3. Remove front door parting seal.

REAR DOOR PARTING SEAL (LOWER)

1. Fully open rear door.
2. Using a remover tool (A), disengage the clips from the rear door parting seal (1).

 : Clip

CAUTION:

- Disengage the clips slowly and carefully.
- Never pull the rear door parting seal strongly.

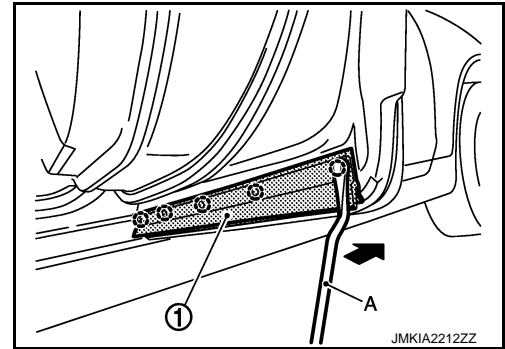

REAR DOOR PARTING SEAL (FRONT)

1. Fully open front door.
2. Pull back rear door parting seal (front).

CAUTION:

Never bend the rear door parting seal strongly.

INSTALLATION

Install in the reverse order of removal.

CAUTION:

- When installing door parting seal, check that blind clips are securely fitted in panel holes on body, and then press them in.
- When installing, check visually the fillet molding and the clips, then replace them with new parts if they have been damaged.
- Replace double-faced adhesive tape on back of rear door parting seal (front) with a new tape if rear door parting seal (front) is reused.
- Remove double-faced adhesive tape remaining on body and back of rear door parting seal (front) using double-faced adhesive tape remover when removing rear door parting seal (front).
- Never wash the vehicle with in 24 hours after installing so as to keep adhesive.

A
B
C
D
E
F
G
H
I
J
EXT
L
M
N
O
P

BACK DOOR FINISHER

< REMOVAL AND INSTALLATION >

BACK DOOR FINISHER

Exploded View

INFOID:000000006342866

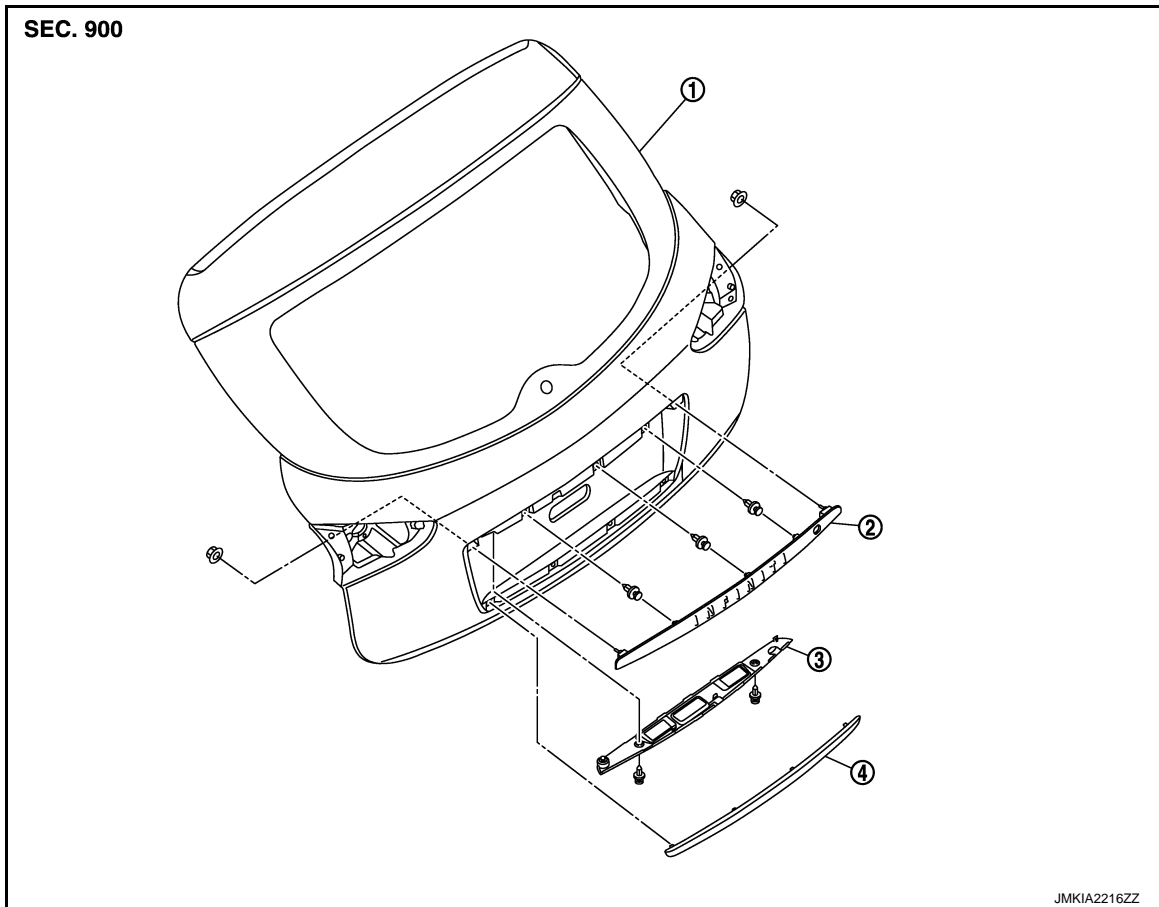

- 1. Back door assembly
- 2. Back door finisher (upper)
- 3. Door handle cover
- 4. Back door finisher (lower)

Removal and Installation

INFOID:000000006342867

REMOVAL

BACK DOOR FINISHER

1. Fully open back door.
2. Remove back door finisher inner. Refer to [INT-41, "Removal and Installation"](#).
3. Remove back door finisher (upper) fixing nuts (A).
4. Disconnect back door request switch harness connector (B).
5. Pull harness grommet (C) outwards from back door to release it.

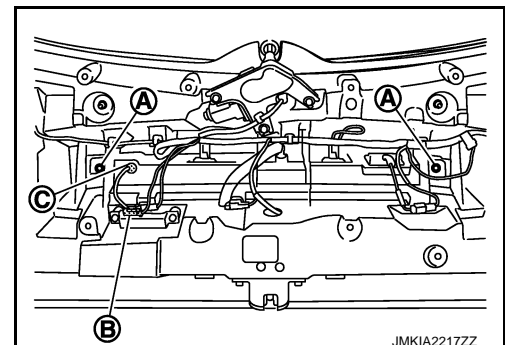

BACK DOOR FINISHER

< REMOVAL AND INSTALLATION >

6. Remove back door finisher (upper) (1) fixing clips with remover tool (A).

CAUTION:

- Apply a protective tape (B) on the body to protect the painted surface from damage.
- Disengage the clips slowly and carefully.
- Never pull the back door finisher (upper) strongly.

 : Clip

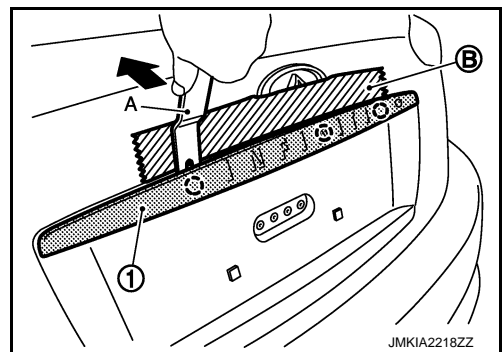

7. Pull back door finisher (upper) to remove it.
8. Remove door handle cover (1) fixing clips (A).
9. Remove door handle fixing pawls, and then pull toward the arrow direction.

 : Clip

 : Pawl

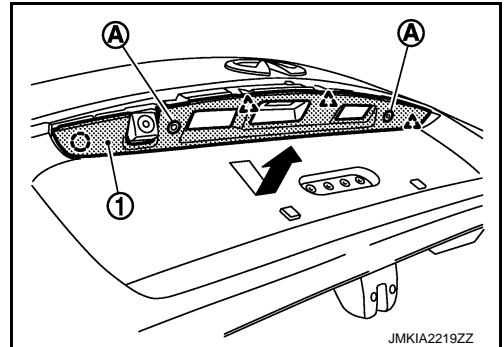

BACK DOOR CENTER FINISHER

1. Remove back door finisher (lower) (1) fixing clips with remover tool (A).

CAUTION:

- Apply a protective tape (B) on the body to protect the painted surface from damage.
- Disengage the clips slowly and carefully.
- Never pull the back door finisher (lower) strongly.

 : Clip

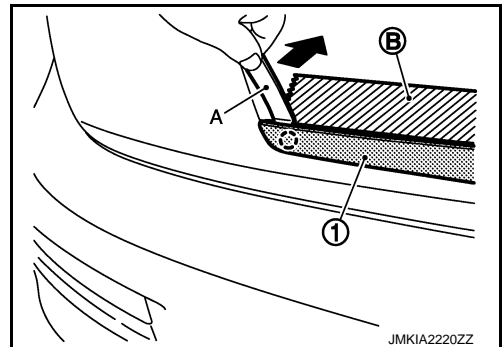

2. Pull back door finisher (lower) to remove it.

INSTALLATION

Install in the reverse order of removal.

A
B
C
D
E
F
G
H
I
J
EXT
L
M
N
O
P