

SECTION **FSU**  
FRONT SUSPENSION

A  
B  
C  
D

**FSU**

CONTENTS

<b>2WD</b>		
<b>SYMPTOM DIAGNOSIS</b> .....	3	
<b>NOISE, VIBRATION AND HARSHNESS (NVH) TROUBLESHOOTING</b> .....	3	
NVH Troubleshooting Chart .....	3	
<b>PRECAUTION</b> .....	4	
<b>PRECAUTIONS</b> .....	4	
Precaution for Supplemental Restraint System (SRS) "AIR BAG" and "SEAT BELT PRE-TENSIONER" .....	4	
Precaution for Procedure without Cowl Top Cover.....	4	
Precautions for Suspension .....	4	
<b>PREPARATION</b> .....	5	
<b>PREPARATION</b> .....	5	
Special Service Tool .....	5	
Commercial Service Tool .....	5	
<b>PERIODIC MAINTENANCE</b> .....	6	
<b>FRONT SUSPENSION ASSEMBLY</b> .....	6	
Inspection .....	6	
<b>WHEEL ALIGNMENT</b> .....	7	
Inspection .....	7	
Adjustment .....	7	
<b>REMOVAL AND INSTALLATION</b> .....	9	
<b>FRONT COIL SPRING AND SHOCK ABSORBER</b> .....	9	
Exploded View .....	9	
Removal and Installation .....	9	
Disassembly and Assembly .....	9	
Inspection .....	12	
Disposal .....	12	
<b>TRANSVERSE LINK</b> .....	13	
Exploded View .....	13	
Removal and Installation .....	13	
Inspection .....	13	
<b>UPPER LINK</b> .....	15	
Exploded View .....	15	
Removal and Installation .....	15	
Inspection .....	15	
<b>FRONT STABILIZER</b> .....	17	
Exploded View .....	17	
Removal and Installation .....	17	
Inspection .....	17	
<b>FRONT SUSPENSION MEMBER</b> .....	18	
Exploded View .....	18	
Removal and Installation .....	18	
Inspection .....	18	
<b>SERVICE DATA AND SPECIFICATIONS (SDS)</b> .....	20	
<b>SERVICE DATA AND SPECIFICATIONS (SDS)</b> .....	20	
Wheel Alignment .....	20	
Ball Joint .....	20	
Wheelarch Height .....	20	
<b>AWD</b>		
<b>SYMPTOM DIAGNOSIS</b> .....	22	
<b>NOISE, VIBRATION AND HARSHNESS (NVH) TROUBLESHOOTING</b> .....	22	
NVH Troubleshooting Chart .....	22	
<b>PRECAUTION</b> .....	23	
<b>PRECAUTIONS</b> .....	23	
Precaution for Supplemental Restraint System (SRS) "AIR BAG" and "SEAT BELT PRE-TENSIONER" .....	23	
Precaution for Procedure without Cowl Top Cover.....	23	

F  
G  
H  
I  
J  
K  
L  
M  
N  
O  
P

Precautions for Suspension .....	23	Exploded View .....	32
<b>PREPARATION .....</b>	<b>24</b>	Removal and Installation .....	32
<b>PREPARATION .....</b>	<b>24</b>	Inspection .....	32
Special Service Tool .....	24	<b>UPPER LINK .....</b>	<b>34</b>
Commercial Service Tool .....	24	Exploded View .....	34
<b>PERIODIC MAINTENANCE .....</b>	<b>25</b>	Removal and Installation .....	34
<b>FRONT SUSPENSION ASSEMBLY .....</b>	<b>25</b>	Inspection .....	34
Inspection .....	25	<b>FRONT STABILIZER .....</b>	<b>36</b>
<b>WHEEL ALIGNMENT .....</b>	<b>26</b>	Exploded View .....	36
Inspection .....	26	Removal and Installation .....	36
Adjustment .....	26	Inspection .....	36
<b>REMOVAL AND INSTALLATION .....</b>	<b>28</b>	<b>FRONT SUSPENSION MEMBER .....</b>	<b>37</b>
<b>FRONT COIL SPRING AND SHOCK AB-</b>		Exploded View .....	37
<b>SORBER .....</b>	<b>28</b>	Removal and Installation .....	37
Exploded View .....	28	Inspection .....	38
Removal and Installation .....	28	<b>SERVICE DATA AND SPECIFICATIONS</b>	
Disassembly and Assembly .....	28	<b>(SDS) .....</b>	<b>39</b>
Inspection .....	31	<b>SERVICE DATA AND SPECIFICATIONS</b>	
Disposal .....	31	<b>(SDS) .....</b>	<b>39</b>
<b>TRANSVERSE LINK .....</b>	<b>32</b>	Wheel Alignment .....	39
		Ball Joint .....	39
		Wheelarch Height .....	39

# NOISE, VIBRATION AND HARSHNESS (NVH) TROUBLESHOOTING

< SYMPTOM DIAGNOSIS >

[2WD]

## SYMPTOM DIAGNOSIS

### NOISE, VIBRATION AND HARSHNESS (NVH) TROUBLESHOOTING

#### NVH Troubleshooting Chart

INFOID:000000007455245

Use chart below to find the cause of the symptom. If necessary, repair or replace these parts.

Symptom	FRONT SUSPENSION	Noise	x	x	x	x	x	x			x	x	x	x	x				
		Shake	x	x	x	x			x			x	x	x	x	x			
		Vibration	x	x	x	x	x					x	x					x	
		Shimmy	x	x	x	x				x			x	x	x	x		x	
		Judder	x	x	x							x	x	x	x			x	
		Poor quality ride or handling	x	x	x	x	x			x	x		x	x					
		Possible cause and SUSPECTED PARTS		Improper installation, looseness	FSU-9, FSU-13, FSU-15, FSU-17, FSU-18														
				Shock absorber deformation, damage or deflection	FSU-12														
				Bushing or mounting deterioration	—														
				Parts interference	—														
				Spring fatigue	FSU-12														
				Suspension looseness	FSU-9, FSU-13, FSU-15, FSU-17, FSU-18														
				Incorrect wheel alignment	FSU-7														
Reference		Stabilizer bar fatigue	FSU-17																
		PROPELLER SHAFT	NVH in DLN section																
		FRONT AXLE AND FRONT SUSPENSION	NVH in FAX and FSU section																
		ROAD WHEEL	NVH in WT section																
		BRAKE	NVH in BR section																
		STEERING	NVH in ST section																

x: Applicable

A  
B  
C  
D  
E  
FSU  
F  
G  
H  
I  
J  
K  
L  
M  
N  
O  
P

## PRECAUTION

### PRECAUTIONS

#### Precaution for Supplemental Restraint System (SRS) "AIR BAG" and "SEAT BELT PRE-TENSIONER"

INFOID:000000007697815

The Supplemental Restraint System such as "AIR BAG" and "SEAT BELT PRE-TENSIONER", used along with a front seat belt, helps to reduce the risk or severity of injury to the driver and front passenger for certain types of collision. This system includes seat belt switch inputs and dual stage front air bag modules. The SRS system uses the seat belt switches to determine the front air bag deployment, and may only deploy one front air bag, depending on the severity of a collision and whether the front occupants are belted or unbelted. Information necessary to service the system safely is included in the "SRS AIR BAG" and "SEAT BELT" of this Service Manual.

**WARNING:**

Always observe the following items for preventing accidental activation.

- To avoid rendering the SRS inoperative, which could increase the risk of personal injury or death in the event of a collision that would result in air bag inflation, all maintenance must be performed by an authorized NISSAN/INFINITI dealer.
- Improper maintenance, including incorrect removal and installation of the SRS, can lead to personal injury caused by unintentional activation of the system. For removal of Spiral Cable and Air Bag Module, see "SRS AIR BAG".
- Never use electrical test equipment on any circuit related to the SRS unless instructed to in this Service Manual. SRS wiring harnesses can be identified by yellow and/or orange harnesses or harness connectors.

#### PRECAUTIONS WHEN USING POWER TOOLS (AIR OR ELECTRIC) AND HAMMERS

**WARNING:**

Always observe the following items for preventing accidental activation.

- When working near the Air Bag Diagnosis Sensor Unit or other Air Bag System sensors with the ignition ON or engine running, never use air or electric power tools or strike near the sensor(s) with a hammer. Heavy vibration could activate the sensor(s) and deploy the air bag(s), possibly causing serious injury.
- When using air or electric power tools or hammers, always switch the ignition OFF, disconnect the battery, and wait at least 3 minutes before performing any service.

#### Precaution for Procedure without Cowl Top Cover

INFOID:000000007455248

When performing the procedure after removing cowl top cover, cover the lower end of windshield with urethane, etc to prevent damage to windshield.

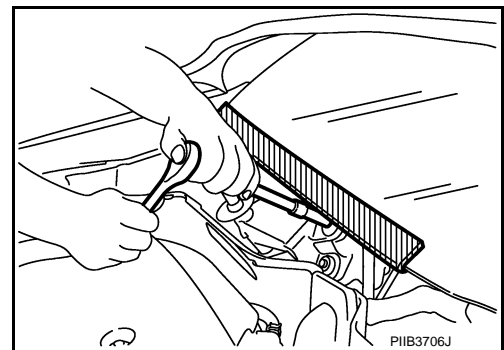

#### Precautions for Suspension

INFOID:000000007455249

- When installing rubber bushings, the final tightening must be carried out under unladen conditions with tires on ground. Spilled oil might shorten the life of rubber bushings. Be sure to wipe off any spilled oil.
- Unladen conditions mean that fuel, engine coolant and lubricant are full. Spare tire, jack, hand tools and mats are in designated positions.
- After servicing suspension parts, be sure to check wheel alignment.
- Self-lock nuts are not reusable. Always use new ones when installing. Since new self-lock nuts are pre-oiled, tighten as they are.

# PREPARATION

< PREPARATION >

[2WD]

## PREPARATION

### PREPARATION

#### Special Service Tool

INFOID:000000007455250

The actual shapes of Kent-Moore tools may differ from those of special service tools illustrated here.

Tool number (Kent-Moore No.) Tool name	Description
ST35652000 ( - ) Shock absorber attachment	Disassembling and assembling shock absorber
ST3127S000 (J-25765-A) Preload gauge	Measuring rotating torque of ball joint

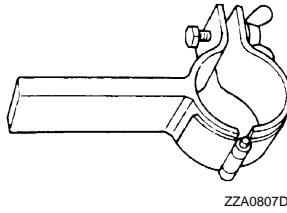

ZZA0807D

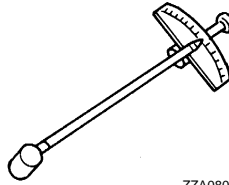

ZZA0806D

#### Commercial Service Tool

INFOID:000000007455251

Tool name	Description
Power tool	Loosening bolts and nuts
Spring compressor	Removing and installing coil spring

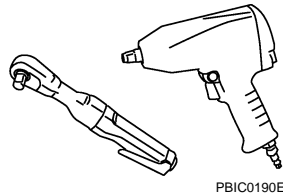

PBIC0190E

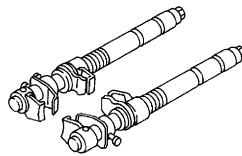

S-NT717

## PERIODIC MAINTENANCE

### FRONT SUSPENSION ASSEMBLY

#### Inspection

INFOID:000000007455252

#### COMPONENT PART

Check the mounting conditions (looseness, backlash) of each component and component conditions (wear, damage) are normal.

#### Ball Joint Axial End Play

1. Set front wheels in a straight-ahead position.
2. Move axle side of transverse link and upper link in the axial direction by hand. Check there is no end play.

**Axial end play** : Refer to [FSU-20. "Ball Joint"](#).

#### CAUTION:

- Never depress brake pedal when measuring.
- Never perform with tires on level ground.
- Be careful not to damage ball joint boot. Never damage the installation position by applying excessive force.

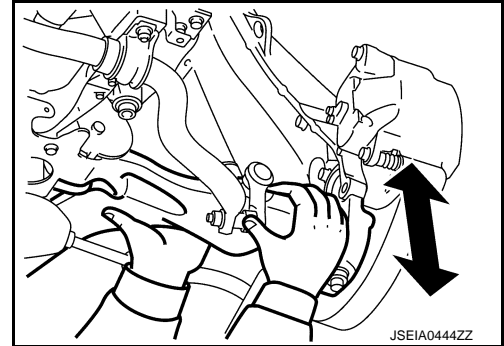

#### Shock absorber

Check for oil leakage, damage. Replace it if necessary.

# WHEEL ALIGNMENT

< PERIODIC MAINTENANCE >

[2WD]

## WHEEL ALIGNMENT

### Inspection

INFOID:000000007455253

### DESCRIPTION

#### CAUTION:

- **Camber, caster, kingpin inclination angles cannot be adjusted.**
- **If camber, caster, or kingpin inclination angle is outside the standard, check front suspension parts for wear and damage. Replace suspect parts if a malfunction is detected.**
- **Kingpin inclination angle is reference value, no inspection is required.**
- **Measure wheel alignment under unladen conditions.**

#### NOTE:

“Unladen conditions” means that fuel, engine coolant, and lubricant are full. Spare tire, jack, hand tools and mats are in designated positions.

### PRELIMINARY CHECK

Check the following:

- Tires for improper air pressure and wear. Refer to [WT-53, "Tire Air Pressure"](#).
- Road wheels for runout.
- Wheel bearing axial end play. Refer to [FAX-6, "Inspection"](#).
- Transverse link or upper link ball joint axial end play. Refer to [FSU-6, "Inspection"](#).
- Shock absorber operation.
- Each mounting part of axle and suspension for looseness and deformation.
- Each of suspension member, shock absorber, upper link and transverse link for cracks, deformation and other damage.
- Vehicle height (posture).

### GENERAL INFORMATION AND RECOMMENDATIONS

- A four-wheel thrust alignment should be performed.
- This type of alignment is recommended for any NISSAN/INFINITI vehicle.
- The four-wheel “thrust” process helps ensure that the vehicle is properly aligned and the steering wheel is centered.
- The alignment rack itself should be capable of accepting any NISSAN/INFINITI vehicle.
- The rack should be checked to ensure that it is level.
- Make sure the machine is properly calibrated.
- Your alignment equipment should be regularly calibrated in order to give correct information.
- Check with the manufacturer of your specific equipment for their recommended Service/Calibration Schedule.

### ALIGNMENT PROCESS

#### IMPORTANT:

Use only the alignment specifications listed in this Service Manual.

- When displaying the alignment settings, many alignment machines use “indicators”: (Green/red, plus or minus, Go/No Go). **Never use these indicators.**
- The alignment specifications programmed into your machine that operate these indicators may not be correct.
- This may result in an ERROR.
- Most camera-type alignment machines are equipped with both “Rolling Compensation” method and optional “Jacking Compensation” method to “compensate” the alignment targets or head units. “Rolling Compensation” is the preferred method.
- If using the “Rolling Compensation” method, after installing the alignment targets or head units, push or pull on the rear wheel to move the vehicle. **Do not push or pull on the vehicle body.**
- If using the “Jacking Compensation” method, after installing the alignment targets or head units, raise the vehicle and rotate the wheels 1/2 turn both ways.

#### NOTE:

- Do not use the “Rolling Compensation” method if you are using sensor-type alignment equipment.
- Follow all instructions for the alignment machine you're using for more information.

### Adjustment

INFOID:000000007687474

### TOE-IN

## WHEEL ALIGNMENT

< PERIODIC MAINTENANCE >

[2WD]

- Loosen the steering outer socket, and then adjust the length using steering inner socket.

**Toe-in** : Refer to [FSU-20, "Wheel Alignment"](#).

**CAUTION:**

- Always evenly adjust both toe-in alternately and adjust the difference between the left and right to the standard.
- Always fix the steering inner socket when tightening the steering outer socket.
- After toe-in adjustment, adjust neutral position of steering angle sensor. Refer to [BRC-9, "ADJUSTMENT OF STEERING ANGLE SENSOR NEUTRAL POSITION : Special Repair Requirement"](#).



# FRONT COIL SPRING AND SHOCK ABSORBER

< REMOVAL AND INSTALLATION >

[2WD]

## REMOVAL AND INSTALLATION

### FRONT COIL SPRING AND SHOCK ABSORBER

Exploded View

INFOID:000000007455254

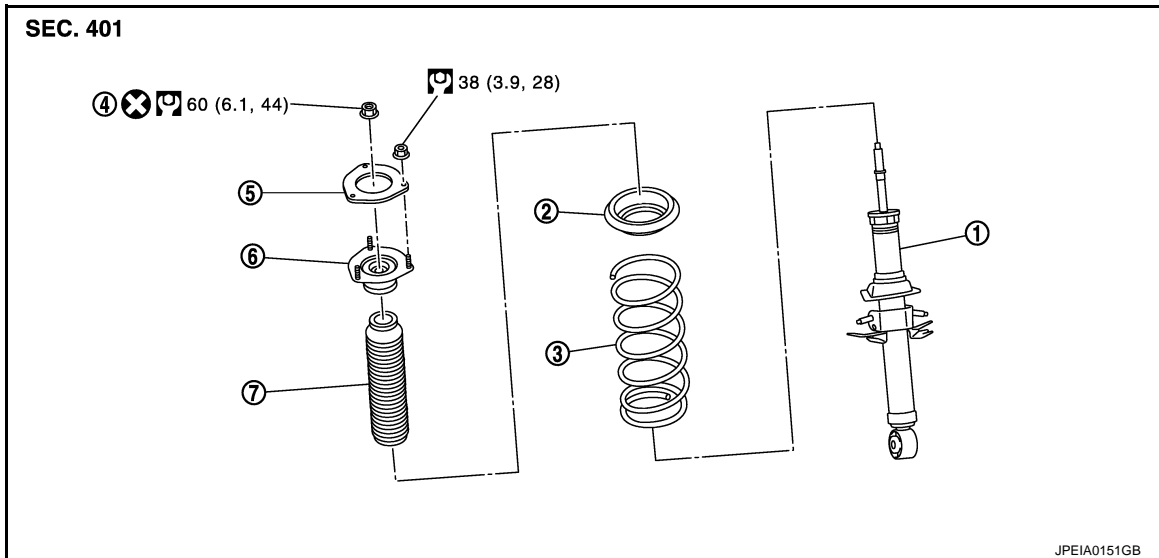

- |                        |                  |                                    |
|------------------------|------------------|------------------------------------|
| 1. Shock absorber      | 2. Rubber seat   | 3. Coil spring                     |
| 4. Piston rod lock nut | 5. Mounting seal | 6. Shock absorber mounting bracket |
| 7. Bound bumper        |                  |                                    |

Refer to [GI-4, "Components"](#) for symbols in the figure.

## Removal and Installation

INFOID:000000007455255

### REMOVAL

1. Remove tires with power tool.
2. Remove wheel sensor and harness connector from shock absorber. Refer to [BRC-121, "FRONT WHEEL SENSOR : Exploded View"](#).
- CAUTION:**  
**Never pull on wheel sensor harness.**
3. Remove brake hose bracket. Refer to [BR-20, "FRONT : Exploded View"](#).
4. Remove stabilizer connecting rod with power tool. Refer to [FSU-17, "Exploded View"](#).
5. Separate upper link from steering knuckle. Refer to [FAX-7, "Exploded View"](#)
6. Remove shock absorber mounting bracket mounting nuts, and remove shock absorber assembly.

### NOTE:

If removing shock absorber is difficult, loosen upper link mounting bolts (vehicle side).

### INSTALLATION

Note the following, and install in the reverse order of removal.

- Never tap on the ball joint cap of the stabilizer connecting rod with a hammer or a similar item when inserting the stabilizer connecting rod into the transverse link.
- Perform final tightening of bolts and nuts at the shock absorber lower side (rubber bushing), under unladen conditions with tires on level ground.

## Disassembly and Assembly

INFOID:000000007455256

### DISASSEMBLY

#### CAUTION:

**Never damage shock absorber piston rod when removing components from shock absorber.**

# FRONT COIL SPRING AND SHOCK ABSORBER

## < REMOVAL AND INSTALLATION >

[2WD]

1. Install shock absorber attachment (A) [SST: ST35652000 ( - )] to shock absorber and secure it in a vise.

**CAUTION:**

**When installing the shock absorber attachment to shock absorber, wrap a shop cloth around shock absorber to protect it from damage.**

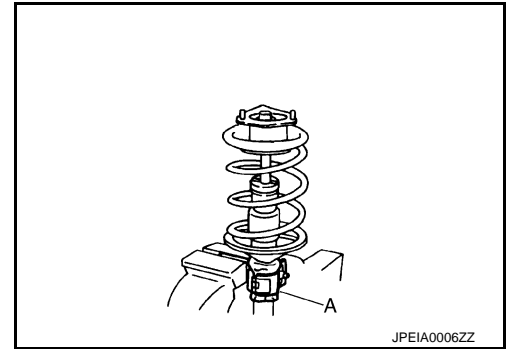

2. Using a spring compressor (A) (commercial service tool), compress coil spring between rubber seat and shock absorber until coil spring with a spring compressor is free.

**CAUTION:**

**Be sure a spring compressor is securely attached coil spring. Compress coil spring.**

3. Make sure coil spring with a spring compressor between rubber seat and shock absorber is free. And then remove piston rod lock nut while securing the piston rod tip so that piston rod does not turn.
4. Remove mounting seal, shock absorber mounting bracket, rubber seat, bound bumper from shock absorber.

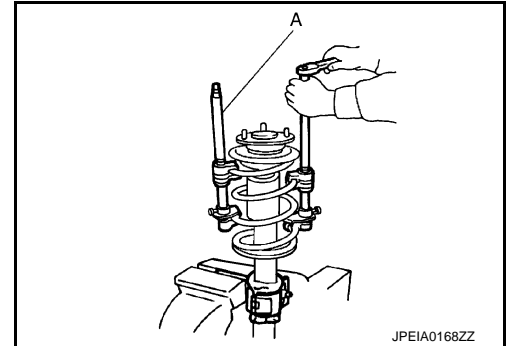

5. After remove coil spring with a spring compressor (commercial service tool), and then gradually release a spring compressor.

**CAUTION:**

**Loosen while making sure coil spring attachment position does not move.**

6. Remove the shock absorber attachment [SST: ST35652000 ( - )] from shock absorber.

## ASSEMBLY

1. Install shock absorber attachment [SST: ST35652000 ( - )] to shock absorber and secure it in a vise.

**CAUTION:**

**When installing the shock absorber attachment to shock absorber, wrap a shop cloth around shock absorber to protect it from damage.**

2. Compress coil spring using a spring compressor (commercial service tool), and install it onto shock absorber.

**CAUTION:**

- Install with the large-diameter side (A) facing up and the small-diameter side (B) facing down.
- Be sure a spring compressor is securely attached to coil spring. Compress coil spring.

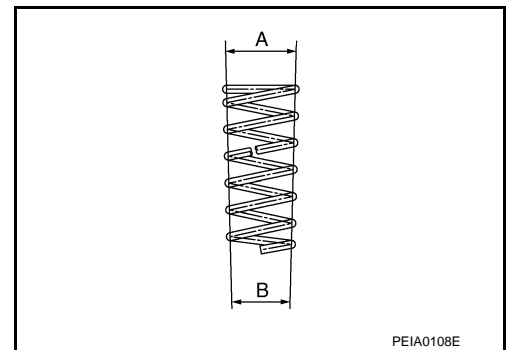

# FRONT COIL SPRING AND SHOCK ABSORBER

< REMOVAL AND INSTALLATION >

[2WD]

3. Install the shock absorber mounting bracket and rubber seat.  
**CAUTION:**  
**Align the paint mark (A) to the stud bolt (1) position when assembling.**
4. Apply soapy water to bound bumper.  
**CAUTION:**  
**Never use machine oil.**

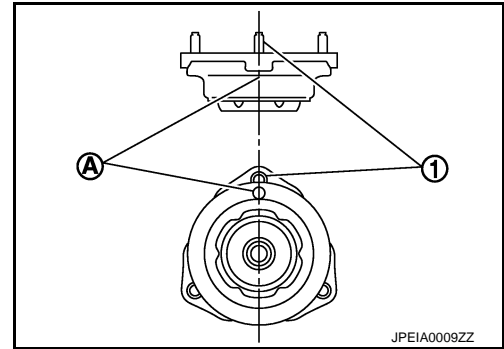

5. Insert bound bumper into shock absorber mounting bracket, and then install it to shock absorber together with rubber seat.

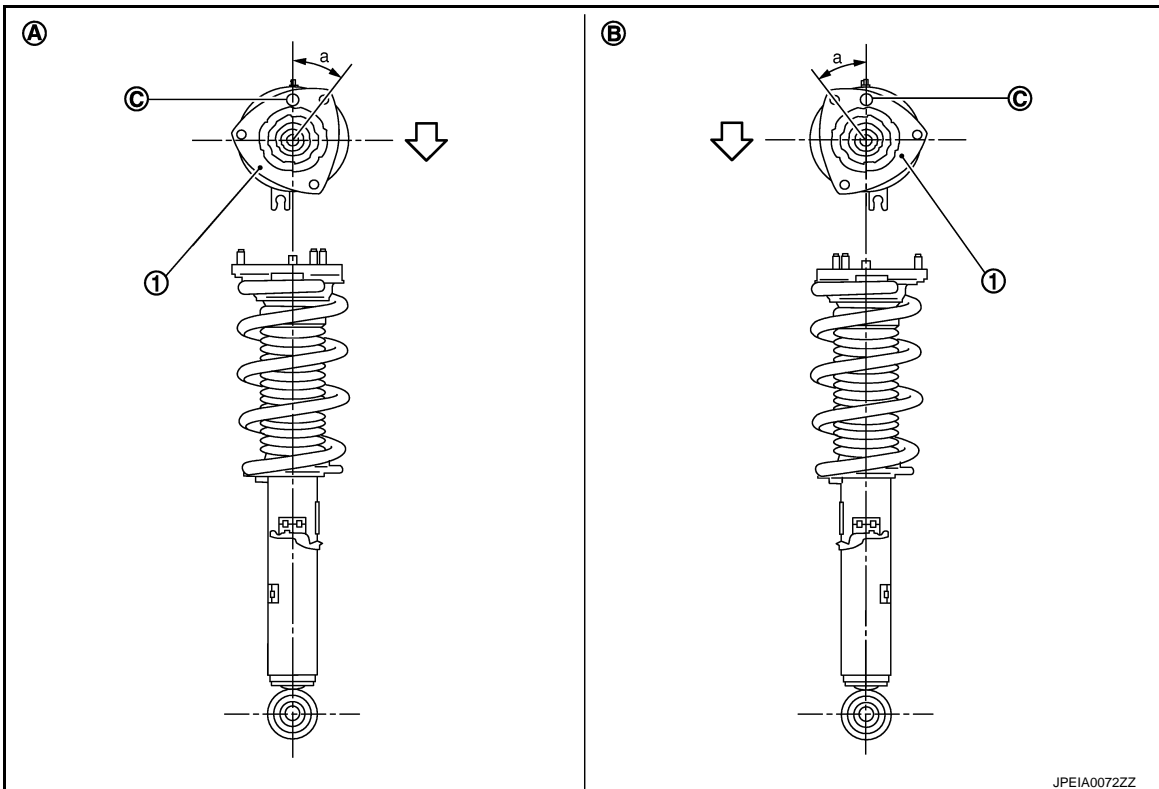

1. shock absorber mounting bracket

A. Right side

B. Left side

C. Coil spring lower end position

⇐: Vehicle front

- Install the shock absorber mounting bracket as shown in the figure.

**Angle (a) : 35.4°**

- Check that the lower end of the coil spring (C) is positioned at the spring lower seat of the shock absorber.

6. Secure piston rod tip so that piston rod does not turn, then tighten piston rod lock nut with specified torque.
7. Gradually release a spring compressor (commercial service tool), and remove coil spring.  
**CAUTION:**  
**Loosen while making sure coil spring attachment position does not move.**
8. Remove the shock absorber attachment [SST: ST35652000 ( - )] from shock absorber.
9. Install the mounting seal to shock absorber mounting bracket.

# FRONT COIL SPRING AND SHOCK ABSORBER

< REMOVAL AND INSTALLATION >

[2WD]

## Inspection

INFOID:000000007455257

### INSPECTION AFTER DISASSEMBLY

#### Shock absorber

Check the following items, and replace the part if necessary.

- Shock absorber for deformation, cracks or damage.
- Piston rod for damage, uneven wear or distortion.
- Oil leakage.

#### Shock absorber Mounting Bracket and Rubber Parts Inspection

Check shock absorber mounting bracket for cracks and rubber parts for wear. Replace it if necessary.

#### Coil Spring

Check coil spring for cracks, wear or damage. Replace it if necessary.

### INSPECTION AFTER INSTALLATION

1. Check wheel sensor harness for proper connection. Refer to [BRC-121, "FRONT WHEEL SENSOR : Exploded View"](#).
2. Check wheel alignment. Refer to [FSU-7, "Inspection"](#).

## Disposal

INFOID:000000007455258

1. Set shock absorber horizontally with the piston rod fully extended.
2. Drill 2 – 3 mm (0.08 – 0.12 in) hole at the position (●) from top as shown in the figure to release gas gradually.

#### CAUTION:

- Wear eye protection (safety glasses).
- Wear gloves.
- Be careful with metal chips or oil blown out by the compressed gas.

#### NOTE:

- Drill vertically in this direction (←).
- Directly to the outer tube avoiding brackets.
- The gas is clear, colorless, odorless, and harmless.

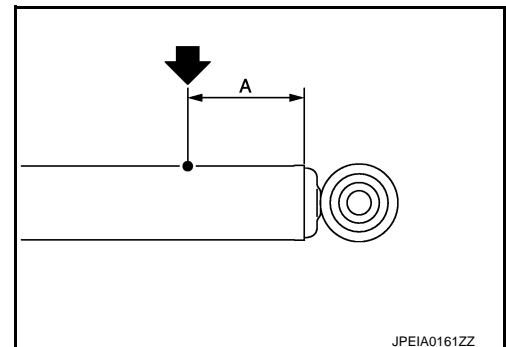

**A : 20 – 30 mm (0.79 – 1.18 in)**

3. Position the drilled hole downward and drain oil by moving the piston rod several times.

#### CAUTION:

**Dispose of drained oil according to the law and local regulations.**

# TRANSVERSE LINK

< REMOVAL AND INSTALLATION >

[2WD]

## TRANSVERSE LINK

### Exploded View

INFOID:000000007455259

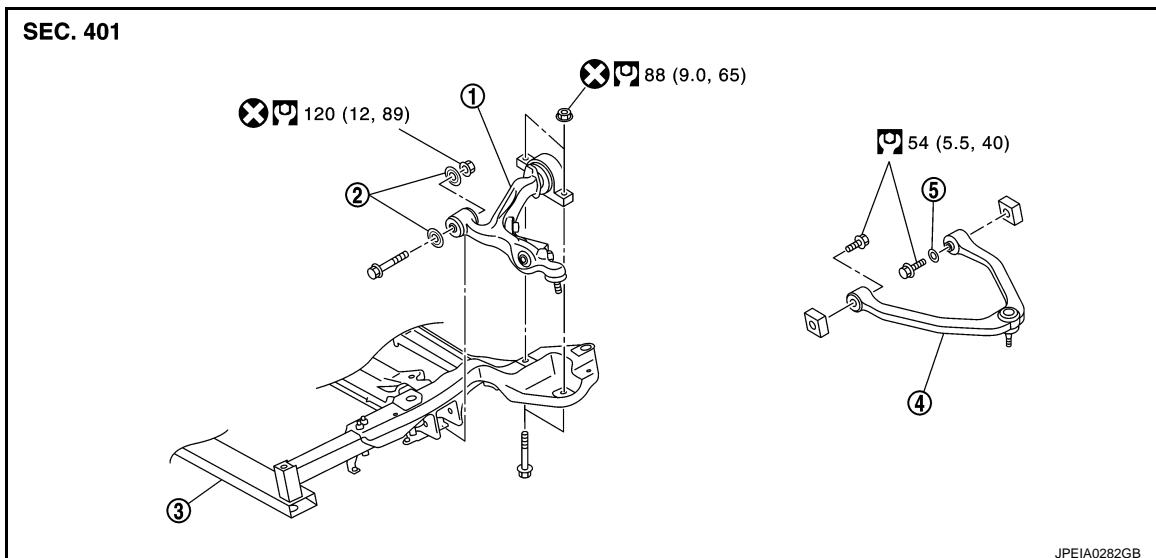

1. Transverse link
2. Stopper bushing
3. Front suspension member
4. Upper link
5. Stopper rubber

Refer to [GI-4, "Components"](#) for symbols in the figure.

## Removal and Installation

INFOID:000000007455260

### REMOVAL

1. Remove tires with power tool.
2. Remove under cover with power tool.
3. Remove shock absorber. Refer to [FSU-9, "Exploded View"](#).
4. Remove steering outer socket from steering knuckle. Refer to [ST-25, "2WD : Exploded View"](#).
5. Remove transverse link from steering knuckle.
6. Set suitable jack under transverse link.
7. Remove transverse link and stopper bushing.

### INSTALLATION

Note the following, and install in the reverse order of removal.

- Never tap on the ball joint cap of the stabilizer connecting rod with a hammer or a similar item when inserting the stabilizer connecting rod into the transverse link.
- Perform final tightening of bolts and nuts at the front suspension member installation and shock absorber lower side (rubber bushing), under unladen conditions with tires on level ground.

## Inspection

INFOID:000000007455261

### INSPECTION AFTER REMOVAL

#### Appearance

Check the following items, and replace the part if necessary.

- Transverse link and bushing for deformation, cracks or damage.
- Ball joint boot for cracks or other damage, and also for grease leakage.

#### Ball Joint Inspection

Manually move ball stud to confirm it moves smoothly with no binding.

#### Swing Torque Inspection

1. Move the ball stud at least ten times by hand to check for smooth movement.

## TRANSVERSE LINK

### < REMOVAL AND INSTALLATION >

[2WD]

- Hook a spring balance (A) at cotter pin mounting hole. Confirm spring balance measurement value is within specifications when ball stud begins moving.

**Swing torque** : Refer to [FSU-20, "Ball Joint"](#).

- If swing torque exceeds standard range, replace transverse link assembly.

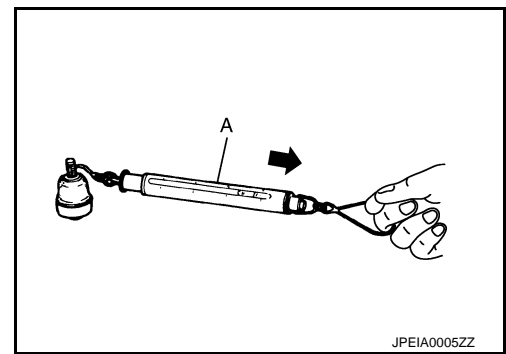

### Rotating Torque Inspection

- Move the ball stud at least ten times by hand to check for smooth movement.
- Attach mounting nut to ball stud. Make sure that rotating torque is within specifications with a preload gauge (A) [SST: ST3127S000 (J-25765-A)].

**Rotating torque** : Refer to [FSU-20, "Ball Joint"](#).

- If rotating torque exceeds standard range, replace transverse link assembly.

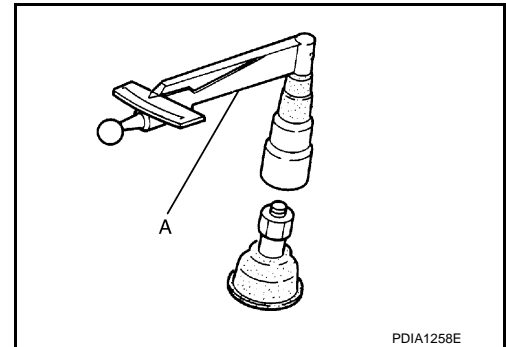

### Axial End Play Inspection

- Move the ball stud at least ten times by hand to check for smooth movement.
- Move tip of ball stud in axial direction to check for looseness.

**Axial end play** : Refer to [FSU-20, "Ball Joint"](#).

- If axial end play exceeds standard range, replace transverse link assembly.

### INSPECTION AFTER INSTALLATION

- Check wheel sensor harness for proper connection. Refer to [BRC-121, "FRONT WHEEL SENSOR : Exploded View"](#).
- Check wheel alignment. Refer to [FSU-7, "Inspection"](#).

# UPPER LINK

< REMOVAL AND INSTALLATION >

[2WD]

## UPPER LINK

### Exploded View

INFOID:000000007455262

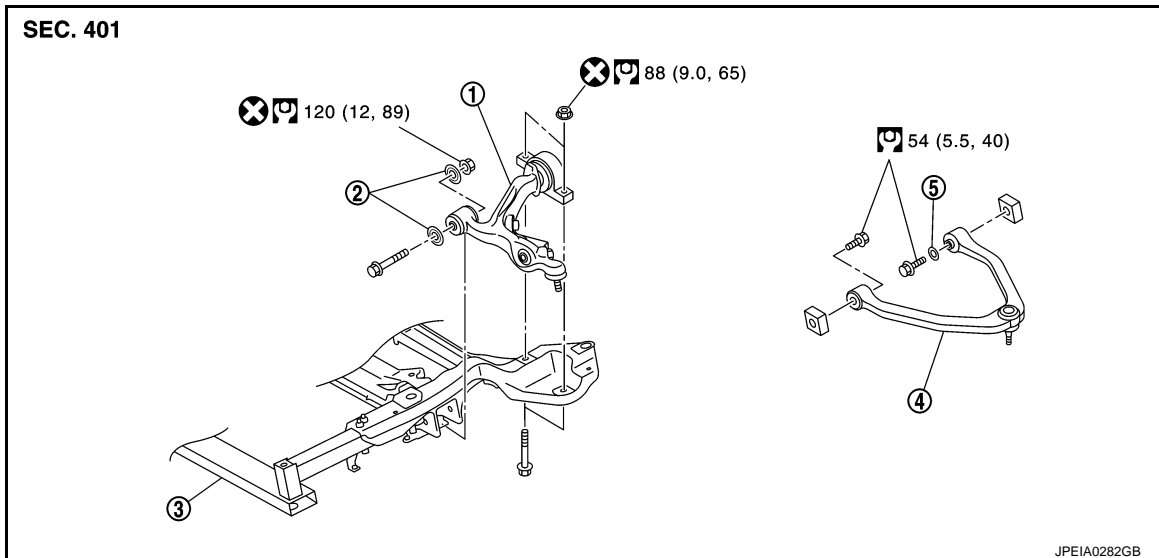

1. Transverse link
2. Stopper bushing
3. Front suspension member
4. Upper link
5. Stopper rubber

Refer to [GI-4, "Components"](#) for symbols in the figure.

## Removal and Installation

INFOID:000000007455263

### REMOVAL

1. Remove tires with power tool.
2. Remove shock absorber. Refer to [FSU-9, "Exploded View"](#).
3. Remove upper link from steering knuckle. Refer to [FAX-7, "Exploded View"](#).
4. Remove upper link and stopper rubber.

### INSTALLATION

Note the following, and install in the reverse order of removal.

- Perform final tightening of bolts and nuts at the vehicle installation position (rubber bushing), under unladen conditions with tires on level ground.

## Inspection

INFOID:000000007455264

### INSPECTION AFTER REMOVAL

#### Appearance

Check the following items, and replace the part if necessary.

- Upper link and bushing for deformation, cracks or damage.
- Ball joint boot for cracks or other damage, and also for grease leakage.

#### Ball Joint Inspection

Manually move ball stud to confirm it moves smoothly with no binding.

#### Swing Torque Inspection

1. Move the ball stud at least ten times by hand to check for smooth movement.

## UPPER LINK

### < REMOVAL AND INSTALLATION >

[2WD]

2. Hook a spring balance (A) at cutout on ball stud. Confirm spring balance measurement value is within specifications when ball stud begins moving.

**Swing torque** : Refer to [FSU-20, "Ball Joint"](#).

- If swing torque exceeds standard range, replace upper link assembly.

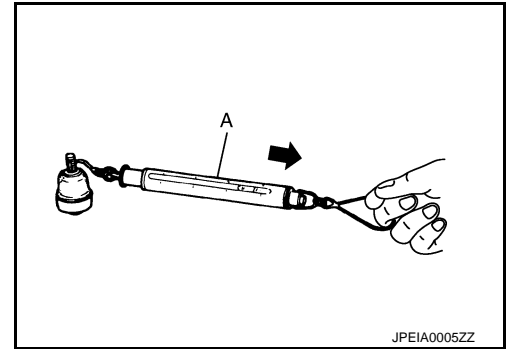

### Axial End Play Inspection

1. Move the ball stud at least ten times by hand to check for smooth movement.
2. Move tip of ball stud in axial direction to check for looseness.

**Axial end play** : Refer to [FSU-20, "Ball Joint"](#).

- If axial end play exceeds standard range, replace upper link assembly.

### INSPECTION AFTER INSTALLATION

1. Check wheel sensor harness for proper connection. Refer to [BRC-121, "FRONT WHEEL SENSOR : Exploded View"](#).
2. Check wheel alignment. Refer to [FSU-7, "Inspection"](#).



# FRONT STABILIZER

< REMOVAL AND INSTALLATION >

[2WD]

## FRONT STABILIZER

Exploded View

INFOID:000000007455265

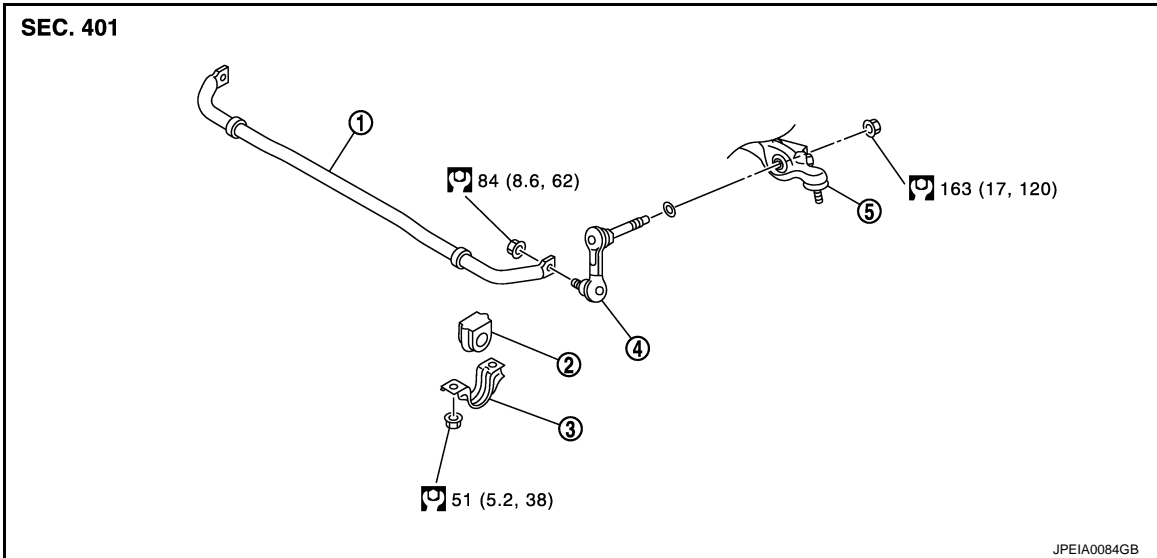

- |                              |                       |                     |
|------------------------------|-----------------------|---------------------|
| 1. Stabilizer bar            | 2. Stabilizer bushing | 3. Stabilizer clamp |
| 4. Stabilizer connecting rod | 5. Transverse link    |                     |

Refer to [GI-4, "Components"](#) for symbols in the figure.

## Removal and Installation

INFOID:000000007455266

### REMOVAL

1. Remove tires with power tool.
2. Remove under cover with power tool.
3. Remove stabilizer connecting rods.

#### **CAUTION:**

**Apply a matching mark to identify the installation position.**

4. Remove stabilizer clamps and stabilizer bushings.
5. Remove stabilizer bar.

### INSTALLATION

Note the following, and install in the reverse order of removal.

- Check the matching mark when installing.
- Tighten the mounting nut to the specified torque while holding a hexagonal part of stabilizer connecting rod side.

## Inspection

INFOID:000000007455267

### INSPECTION AFTER REMOVAL

Check stabilizer bar, stabilizer connecting rod, stabilizer bushing and stabilizer clamp for deformation, cracks or damage. Replace it if necessary.

# FRONT SUSPENSION MEMBER

< REMOVAL AND INSTALLATION >

[2WD]

## FRONT SUSPENSION MEMBER

Exploded View

INFOID:000000007455268

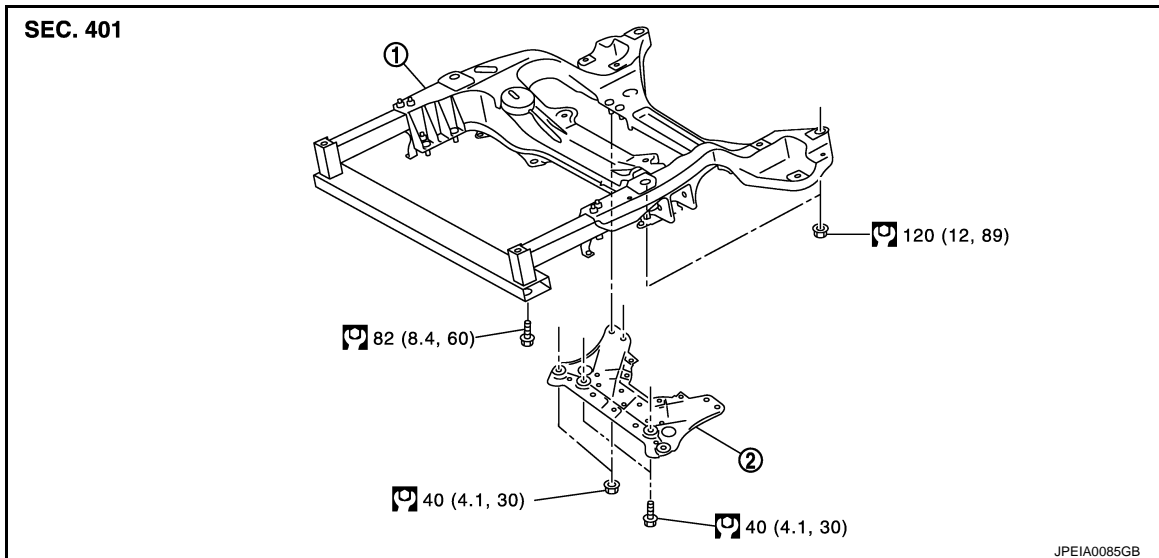

1. Front suspension member
2. Suspension member stay

Refer to [GI-4, "Components"](#) for symbols in the figure.

## Removal and Installation

INFOID:000000007455269

### REMOVAL

1. Remove tires with power tool.
2. Remove under cover with power tool.
3. Remove suspension member stays with power tool.
4. Separate steering gear assembly and lower joint. Refer to [ST-25, "2WD : Exploded View"](#).
5. Remove steering outer sockets from steering knuckles. Refer to [ST-25, "2WD : Exploded View"](#).
6. Remove wheel sensors and sensor harness from steering knuckles. Refer to [BRC-121, "FRONT WHEEL SENSOR : Exploded View"](#).
7. Remove stabilizer connecting rods and stabilizer bar. Refer to [FSU-17, "Exploded View"](#).
8. Install engine slinger, and then hoist engine. Refer to [EM-79, "2WD : Removal and Installation"](#).
9. Remove transverse link from front suspension member. Refer to [FSU-13, "Exploded View"](#).
10. Remove steering hydraulic piping bracket and steering gear from front suspension member. Refer to [ST-51, "2WD : Exploded View"](#).
11. Set suitable jack front suspension member.
12. Remove mounting nuts between engine mounting insulator and from suspension member. Refer to [EM-79, "2WD : Exploded View"](#).
13. Remove mounting bolts and nuts of front suspension member with power tool.
14. Gradually lower jack to remove front suspension assembly from vehicle.

### INSTALLATION

Note the following, and install in the reverse order of removal.

- Perform final tightening of bolts and nuts at the vehicle installation position (rubber bushing), under unladen condition with tires on level ground.

### Inspection

INFOID:000000007455270

### INSPECTION AFTER REMOVAL

Check the front suspension member for significant deformation, cracks, or damages. Replace if necessary.

# FRONT SUSPENSION MEMBER

< REMOVAL AND INSTALLATION >

[2WD]

## INSPECTION AFTER INSTALLATION

1. Check wheel sensor harness for proper connection. Refer to [BRC-121, "FRONT WHEEL SENSOR : Exploded View"](#).
2. Check wheel alignment. Refer to [FSU-7, "Inspection"](#).

A

B

C

D

FSU

F

G

H

I

J

K

L

M

N

O

P

## SERVICE DATA AND SPECIFICATIONS (SDS)

< SERVICE DATA AND SPECIFICATIONS (SDS)

[2WD]

# SERVICE DATA AND SPECIFICATIONS (SDS)

## SERVICE DATA AND SPECIFICATIONS (SDS)

### Wheel Alignment

INFOID:000000007455271

Item		Standard	
Camber Degree minute (Decimal degree)	Minimum	-0° 40' (-0.66°)	
	Nominal	0° 05' (0.08°)	
	Maximum	0° 50' (0.83°)	
	Left and right difference	0° 33' (0.55°) or less	
Caster Degree minute (Decimal degree)	Minimum	3° 30' (3.50°)	
	Nominal	4° 15' (4.25°)	
	Maximum	5° 00' (5.00°)	
	Left and right difference	0° 39' (0.65°) or less	
Kingpin inclination Degree minute (Decimal degree)	Minimum	6° 05' (6.09°)	
	Nominal	6°50' (6.83°)	
	Maximum	7° 35' (7.58°)	
Toe-in	Total toe-in Distance	Minimum	Out 1 mm (Out 0.03 in)
		Nominal	In 1 mm (In 0.04 in)
		Maximum	In 3 mm (In 0.11 in)
	Total toe-angle Degree minute (Decimal degree)	Minimum	Out 0° 04 48" (Out 0.08°)
		Nominal	In 0° 04' 48" (In 0.08°)
		Maximum	In 0° 14' 24" (In 0.24°)

Measure value under unladen\* conditions.

\*: Fuel, engine coolant and lubricant are full. Spare tire, jack, hand tools and mats are in designated positions.

### Ball Joint

INFOID:000000007455272

Item		Standard
Swing torque	Transverse link	0.5 – 3.6 N·m (0.06 – 0.36 kg·m, 5 – 31 in-lb)
	Upper link	0 – 2.0 N·m (0 – 0.20 kg·m, 0 – 17 in-lb)
Measurement on spring balance	Transverse link	7.8 – 56.3 N (0.8 – 5.7 kg, 1.8 – 12.6 lb)
	Upper link	0 – 61.5 N (0 – 6.2 kg, 0 – 13.8 lb)
Rotating torque	Transverse link	0.5 – 3.9 N·m (0.06 – 0.39 kg·m, 5 – 34 in-lb)
Axial end play		0 mm (0 in)

### Wheelarch Height

INFOID:000000007455273

Item	Standard	
Wheel size	18 inch	19 inch
Front (Hf)	750 mm (29.53 in)	751 mm (29.57 in)

# SERVICE DATA AND SPECIFICATIONS (SDS)

< SERVICE DATA AND SPECIFICATIONS (SDS)

[2WD]

Item	Standard	
Wheel size	18 inch	19 inch
Rear (Hr)	762 mm (30.00 in)	764 mm (30.08 in)

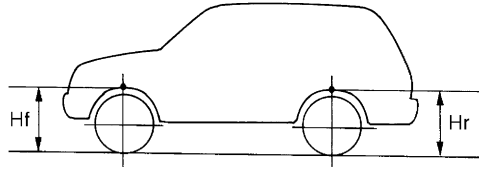

SFA746B

Measure value under unladen\* conditions

\*: Fuel, engine coolant and lubricant are full. Spare tire, jack, hand tools and mats are in designated positions.

A  
B  
C  
D  
F  
G  
H  
I  
J  
K  
L  
M  
N  
O  
P

**FSU**

# NOISE, VIBRATION AND HARSHNESS (NVH) TROUBLESHOOTING

< SYMPTOM DIAGNOSIS >

[AWD]

## SYMPTOM DIAGNOSIS

### NOISE, VIBRATION AND HARSHNESS (NVH) TROUBLESHOOTING

#### NVH Troubleshooting Chart

INFOID:000000007455274

Use chart below to find the cause of the symptom. If necessary, repair or replace these parts.

Symptom		Possible cause and SUSPECTED PARTS														Reference			
		Improper installation, looseness	Strut deformation, damage or deflection	Bushing or mounting deterioration	Parts interference	Spring fatigue	Suspension looseness	Incorrect wheel alignment	Stabilizer bar fatigue	PROPELLER SHAFT	DIFFERENTIAL	FRONT AXLE AND FRONT SUSPENSION	TIRE	ROAD WHEEL	DRIVE SHAFT		BRAKE	STEERING	
Symptom	FRONT SUSPENSION	Noise	x	x	x	x	x	x			x	x	x	x	x	x	x	x	FSU-28, FSU-32, FSU-34, FSU-36, FSU-37
		Shake	x	x	x	x		x			x		x	x	x	x	x	x	FSU-31
		Vibration	x	x	x	x	x				x		x	x		x		x	—
		Shimmy	x	x	x	x			x				x	x	x		x	x	—
		Judder	x	x	x								x	x	x		x	x	FSU-31
		Poor quality ride or handling	x	x	x	x	x		x	x			x	x	x				FSU-28, FSU-32, FSU-34, FSU-36, FSU-37
																		FSU-26	
																		FSU-36	
																		NVH in DLN section.	
																		NVH in DLN section.	
																		NVH in FAX and FSU sections.	
																		NVH in WT section.	
																		NVH in WT section.	
																		NVH in FAX section.	
																		NVH in BR section.	
																		NVH in ST section.	

x: Applicable

PRECAUTION

PRECAUTIONS

Precaution for Supplemental Restraint System (SRS) "AIR BAG" and "SEAT BELT PRE-TENSIONER"

INFOID:000000007455275

The Supplemental Restraint System such as "AIR BAG" and "SEAT BELT PRE-TENSIONER", used along with a front seat belt, helps to reduce the risk or severity of injury to the driver and front passenger for certain types of collision. This system includes seat belt switch inputs and dual stage front air bag modules. The SRS system uses the seat belt switches to determine the front air bag deployment, and may only deploy one front air bag, depending on the severity of a collision and whether the front occupants are belted or unbelted. Information necessary to service the system safely is included in the "SRS AIR BAG" and "SEAT BELT" of this Service Manual.

**WARNING:**

Always observe the following items for preventing accidental activation.

- To avoid rendering the SRS inoperative, which could increase the risk of personal injury or death in the event of a collision that would result in air bag inflation, all maintenance must be performed by an authorized NISSAN/INFINITI dealer.
- Improper maintenance, including incorrect removal and installation of the SRS, can lead to personal injury caused by unintentional activation of the system. For removal of Spiral Cable and Air Bag Module, see "SRS AIR BAG".
- Never use electrical test equipment on any circuit related to the SRS unless instructed to in this Service Manual. SRS wiring harnesses can be identified by yellow and/or orange harnesses or harness connectors.

PRECAUTIONS WHEN USING POWER TOOLS (AIR OR ELECTRIC) AND HAMMERS

**WARNING:**

Always observe the following items for preventing accidental activation.

- When working near the Air Bag Diagnosis Sensor Unit or other Air Bag System sensors with the ignition ON or engine running, never use air or electric power tools or strike near the sensor(s) with a hammer. Heavy vibration could activate the sensor(s) and deploy the air bag(s), possibly causing serious injury.
- When using air or electric power tools or hammers, always switch the ignition OFF, disconnect the battery, and wait at least 3 minutes before performing any service.

Precaution for Procedure without Cowl Top Cover

INFOID:000000007455277

When performing the procedure after removing cowl top cover, cover the lower end of windshield with urethane, etc to prevent damage to windshield.

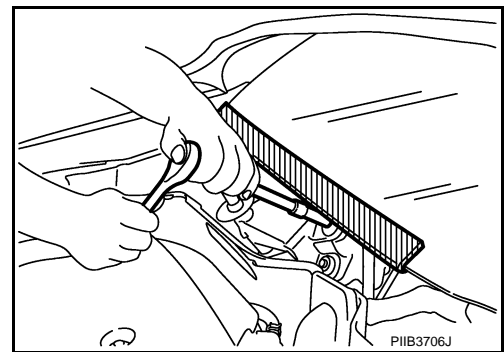

Precautions for Suspension

INFOID:000000007455278

- When installing rubber bushings, the final tightening must be carried out under unladen conditions with tires on ground. Spilled oil might shorten the life of rubber bushings. Be sure to wipe off any spilled oil.
- Unladen conditions mean that fuel, engine coolant and lubricant are full. Spare tire, jack, hand tools and mats are in designated positions.
- After servicing suspension parts, be sure to check wheel alignment.
- Self-lock nuts are not reusable. Always use new ones when installing. Since new self-lock nuts are pre-oiled, tighten as they are.

A  
B  
C  
D  
FSU  
F  
G  
H  
I  
J  
K  
L  
M  
N  
O  
P

# PREPARATION

[AWD]

< PREPARATION >

## PREPARATION

### PREPARATION

#### Special Service Tool

INFOID:000000007455279

The actual shapes of Kent-Moore tools may differ from those of special service tools illustrated here.

Tool number (Kent-Moore No.) Tool name	Description
ST35652000 ( - ) Shock absorber attachment	Disassembling and assembling shock absorber
ST3127S000 (J-25765-A) Preload gauge	Measuring rotating torque of ball joint

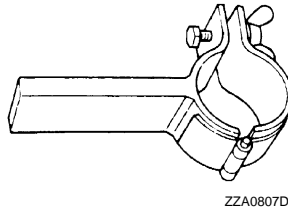

ZZA0807D

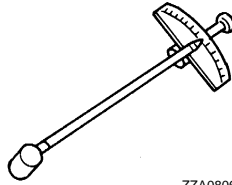

ZZA0806D

#### Commercial Service Tool

INFOID:000000007455280

Tool name	Description
Power tool	Loosening bolts and nuts
Spring compressor	Removing and installing coil spring

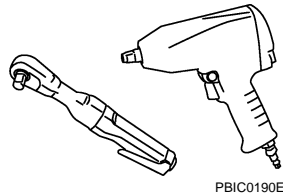

PBIC0190E

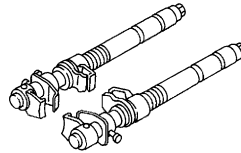

S-NT717



# FRONT SUSPENSION ASSEMBLY

< PERIODIC MAINTENANCE >

[AWD]

## PERIODIC MAINTENANCE

### FRONT SUSPENSION ASSEMBLY

#### Inspection

INFOID:000000007455281

#### COMPONENT PART

Check the mounting conditions (looseness, backlash) of each component and component conditions (wear, damage) are normal.

#### Ball Joint Axial End Play

1. Set front wheels in a straight-ahead position.
2. Move axle side of transverse link and upper link in the axial direction by hand. Check there is no end play.

**Axial end play** : Refer to [FSU-39. "Ball Joint"](#).

#### CAUTION:

- Never depress brake pedal when measuring.
- Never perform with tires on level ground.
- Be careful not to damage ball joint boot. Never damage the installation position by applying excessive force.

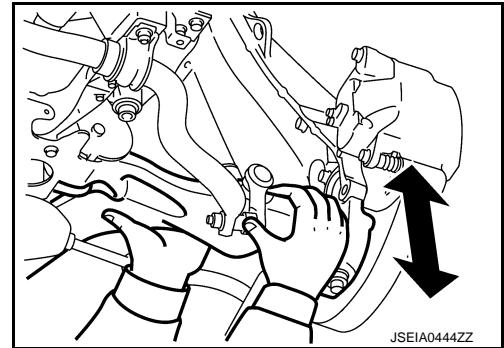

#### Shock absorber

Check for oil leakage, damage. Replace it if necessary.

A  
B  
C  
D  
FSU  
F  
G  
H  
I  
J  
K  
L  
M  
N  
O  
P

## WHEEL ALIGNMENT

### Inspection

INFOID:000000007455282

### DESCRIPTION

#### CAUTION:

- **Camber, caster, kingpin inclination angles cannot be adjusted.**
- **If camber, caster, or kingpin inclination angle is outside the standard, check front suspension parts for wear and damage. Replace suspect parts if a malfunction is detected.**
- **Kingpin inclination angle is reference value, no inspection is required.**
- **Measure wheel alignment under unladen conditions.**

#### NOTE:

“Unladen conditions” means that fuel, engine coolant, and lubricant are full. Spare tire, jack, hand tools and mats are in designated positions.

### PRELIMINARY CHECK

Check the following:

- Tires for improper air pressure and wear. Refer to [WT-53, "Tire Air Pressure"](#).
- Road wheels for runout.
- Wheel bearing axial end play. Refer to [FAX-14, "Inspection"](#).
- Transverse link or upper link ball joint axial end play. Refer to [FSU-25, "Inspection"](#).
- shock absorber operation.
- Each mounting part of axle and suspension for looseness and deformation.
- Each of suspension member, shock absorber, upper link and transverse link for cracks, deformation and other damage.
- Vehicle height (posture).

### GENERAL INFORMATION AND RECOMMENDATIONS

- A four-wheel thrust alignment should be performed.
- This type of alignment is recommended for any NISSAN/INFINITI vehicle.
- The four-wheel “thrust” process helps ensure that the vehicle is properly aligned and the steering wheel is centered.
- The alignment rack itself should be capable of accepting any NISSAN/INFINITI vehicle.
- The rack should be checked to ensure that it is level.
- Make sure the machine is properly calibrated.
- Your alignment equipment should be regularly calibrated in order to give correct information.
- Check with the manufacturer of your specific equipment for their recommended Service/Calibration Schedule.

### ALIGNMENT PROCESS

#### IMPORTANT:

Use only the alignment specifications listed in this Service Manual.

- When displaying the alignment settings, many alignment machines use “indicators”: (Green/red, plus or minus, Go/No Go). **Never use these indicators.**
- The alignment specifications programmed into your machine that operate these indicators may not be correct.
- This may result in an ERROR.
- Most camera-type alignment machines are equipped with both “Rolling Compensation” method and optional “Jacking Compensation” method to “compensate” the alignment targets or head units. “Rolling Compensation” is the preferred method.
- If using the “Rolling Compensation” method, after installing the alignment targets or head units, push or pull on the rear wheel to move the vehicle. **Do not push or pull on the vehicle body.**
- If using the “Jacking Compensation” method, after installing the alignment targets or head units, raise the vehicle and rotate the wheels 1/2 turn both ways.

#### NOTE:

- Do not use the “Rolling Compensation” method if you are using sensor-type alignment equipment.
- Follow all instructions for the alignment machine you're using for more information.

### Adjustment

INFOID:000000007687475

### TOE-IN

# WHEEL ALIGNMENT

< PERIODIC MAINTENANCE >

[AWD]

- Loosen the steering outer socket, and then adjust the length using steering inner socket.

**Toe-in** : Refer to [FSU-39, "Wheel Alignment"](#).

**CAUTION:**

- Always evenly adjust both toe-in alternately and adjust the difference between the left and right to the standard.
- Always fix the steering inner socket when tightening the steering outer socket.
- After toe-in adjustment, adjust neutral position of steering angle sensor. Refer to [BRC-9, "ADJUSTMENT OF STEERING ANGLE SENSOR NEUTRAL POSITION : Special Repair Requirement"](#).

A  
B  
C  
D  
F  
G  
H  
I  
J  
K  
L  
M  
N  
O  
P

FSU

# FRONT COIL SPRING AND SHOCK ABSORBER

< REMOVAL AND INSTALLATION >

[AWD]

## REMOVAL AND INSTALLATION

### FRONT COIL SPRING AND SHOCK ABSORBER

Exploded View

INFOID:000000007455283

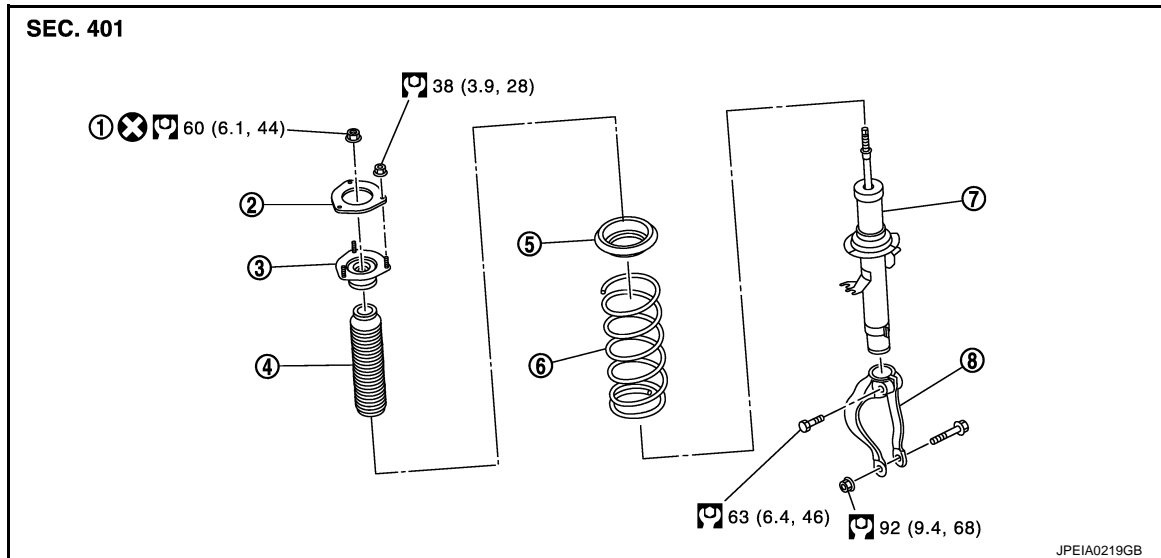

- |                        |                       |                                    |
|------------------------|-----------------------|------------------------------------|
| 1. Piston rod lock nut | 2. Mounting seal      | 3. Shock absorber mounting bracket |
| 4. Bound bumper        | 5. Rubber seat        | 6. Coil spring                     |
| 7. Shock absorber      | 8. Shock absorber arm |                                    |

Refer to [GI-4, "Components"](#) for symbols in the figure.

## Removal and Installation

INFOID:000000007455284

### REMOVAL

1. Remove tires with power tool.
2. Remove wheel sensor and harness connector from shock absorber. Refer to [BRC-121, "FRONT WHEEL SENSOR : Exploded View"](#).
3. Remove brake hose bracket. Refer to [BR-20, "FRONT : Exploded View"](#).
4. Remove stabilizer connecting rod with power tool. Refer to [FSU-36, "Exploded View"](#).
5. Remove shock absorber from transverse link with power tool.
6. Separate upper link from steering knuckle. Refer to [FAX-16, "Exploded View"](#).
7. Remove shock absorber assembly.

#### NOTE:

If removing shock absorber is difficult, loosen upper link mounting bolts (vehicle side).

### INSTALLATION

Note the following, and install in the reverse order of removal.

- Never tap on the ball joint cap of the stabilizer connecting rod with a hammer or a similar item when inserting the stabilizer connecting rod into the transverse link.
- Perform final tightening of bolts and nuts at the shock absorber lower side (rubber bushing), under unladen conditions with tires on level ground.

## Disassembly and Assembly

INFOID:000000007455285

### DISASSEMBLY

**CAUTION:**

# FRONT COIL SPRING AND SHOCK ABSORBER

< REMOVAL AND INSTALLATION >

[AWD]

**Never damage shock absorber piston rod when removing components from shock absorber.**

1. Remove the shock absorber arm from shock absorber.
2. Install shock absorber attachment (A) [SST: ST35652000 ( - )] to shock absorber and secure it in a vise.

**CAUTION:**

**When installing the shock absorber attachment to shock absorber, wrap a shop cloth around shock absorber to protect it from damage.**

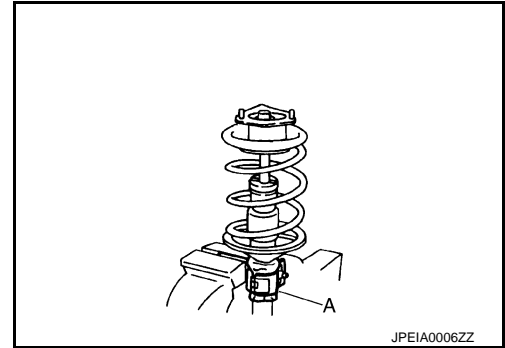

3. Using a spring compressor (A) (commercial service tool), compress coil spring between rubber seat and shock absorber until coil spring with a spring compressor is free.

**CAUTION:**

**Be sure a spring compressor is securely attached coil spring. Compress coil spring**

4. Make sure coil spring with a spring compressor between rubber seat and shock absorber is free. And then remove piston rod lock nut while securing the piston rod tip so that piston rod does not turn.
5. Remove mounting seal, shock absorber mounting bracket, rubber seat, bound bumper from shock absorber.
6. After remove coil spring with a spring compressor (commercial service tool), and then gradually release a spring compressor.

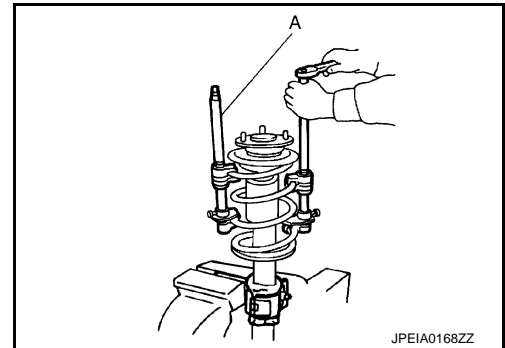

**CAUTION:**

**Loosen while making sure coil spring attachment position does not move.**

7. Remove the shock absorber attachment [SST: ST35652000 ( - )] from shock absorber.

## ASSEMBLY

1. Install shock absorber attachment [SST: ST35652000 ( - )] to shock absorber and secure it in a vise.

**CAUTION:**

**When installing the shock absorber attachment to shock absorber, wrap a shop cloth around shock absorber to protect it from damage.**

2. Compress coil spring using a spring compressor (commercial service tool), and install it onto shock absorber.

**CAUTION:**

- Install with the large-diameter side (A) facing up and the small-diameter side (B) facing down.
- Be sure a spring compress or is securely attached to coil spring. Compress coil spring.

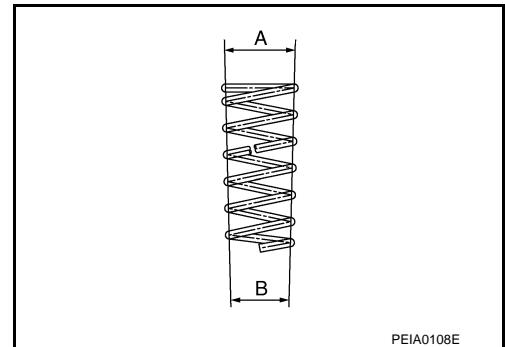

A  
B  
C  
D  
FSU  
F  
G  
H  
I  
J  
K  
L  
M  
N  
O  
P

# FRONT COIL SPRING AND SHOCK ABSORBER

< REMOVAL AND INSTALLATION >

[AWD]

3. Install the shock absorber mounting bracket and rubber seat.  
**CAUTION:**  
**Align the paint mark (A) to the stud bolt (1) position when assembling.**
4. Apply soapy water to bound bumper.  
**CAUTION:**  
**Never use machine oil.**

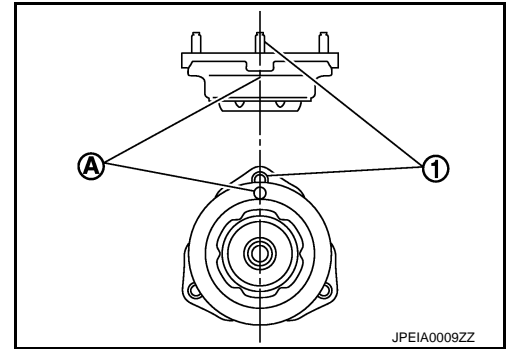

5. Insert bound bumper into shock absorber mounting bracket, and then install it to shock absorber together with rubber seat.

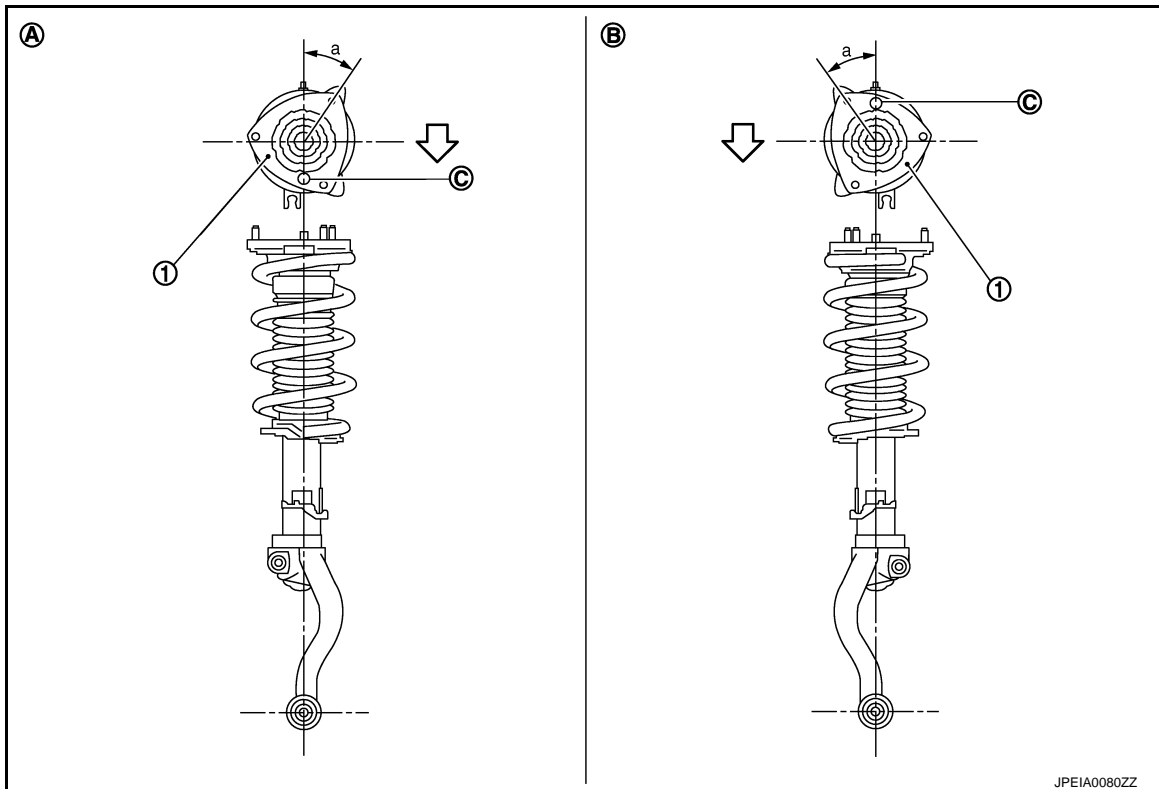

1. shock absorber mounting bracket

A. Right side

B. Left side

C. Coil spring lower end position

⇐: Vehicle front

- Install the shock absorber mounting bracket as shown in the figure.

**Angle (a) : 35.4°**

- Check that the lower end of the coil spring (C) is positioned at the spring lower seat of the shock absorber.
6. Secure piston rod tip so that piston rod does not turn, then tighten piston rod lock nut with specified torque.
  7. Gradually release a spring compressor (commercial service tool), and remove coil spring.  
**CAUTION:**  
**Loosen while making sure coil spring attachment position does not move.**
  8. Remove the shock absorber attachment [SST: ST35652000 ( - )] from shock absorber.
  9. Install the shock absorber arm to shock absorber.  
**CAUTION:**

# FRONT COIL SPRING AND SHOCK ABSORBER

< REMOVAL AND INSTALLATION >

[AWD]

To install, align the shock absorber protrusion (A) with the groove of shock absorber arm (1) and press it all the way to the locating bracket (B).

10. Install the mounting seal to shock absorber mounting bracket.

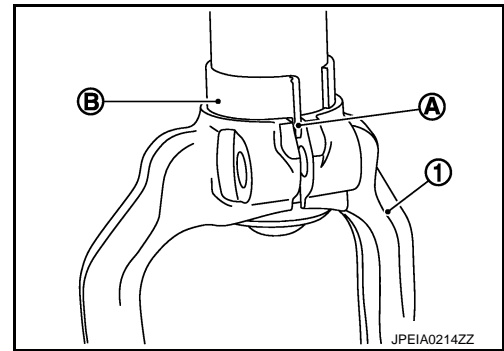

INFOID:000000007455286

## Inspection

### INSPECTION AFTER DISASSEMBLY

#### Shock absorber

Check the following items, and replace the part if necessary.

- Shock absorber for deformation, cracks or damage.
- Piston rod for damage, uneven wear or distortion.
- Oil leakage.

#### Shock absorber Mounting Bracket and Rubber Parts Inspection

Check shock absorber mounting bracket for cracks and rubber parts for wear. Replace it if necessary

#### Coil Spring

Check coil spring for cracks, wear or damage. Replace it if necessary.

### INSPECTION AFTER INSTALLATION

1. Check wheel sensor harness for proper connection. Refer to [BRC-121. "FRONT WHEEL SENSOR : Exploded View"](#).
2. Check wheel alignment. Refer to [FSU-26. "Inspection"](#).

## Disposal

INFOID:000000007455287

1. Set shock absorber horizontally with the piston rod fully extended.
2. Drill 2 – 3 mm (0.08 – 0.12 in) hole at the position (●) from top as shown in the figure to release gas gradually.

#### CAUTION:

- Wear eye protection (safety glasses).
- Wear gloves.
- Be careful with metal chips or oil blown out by the compressed gas.

#### NOTE:

- Drill vertically in this direction (←).
- Directly to the outer tube avoiding brackets.
- The gas is clear, colorless, odorless, and harmless.

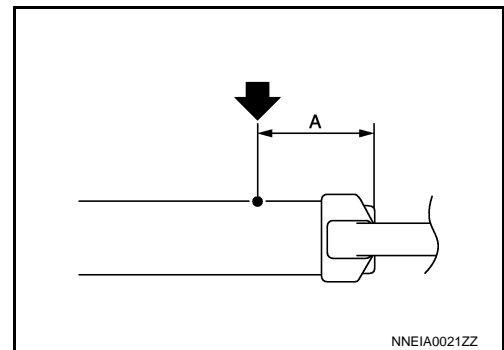

**A** : 20 – 30 mm (0.79 – 1.18 in)

3. Position the drilled hole downward and drain oil by moving the piston rod several times.

#### CAUTION:

Dispose of drained oil according to the law and local regulations.

# TRANSVERSE LINK

< REMOVAL AND INSTALLATION >

[AWD]

## TRANSVERSE LINK

### Exploded View

INFOID:000000007455288

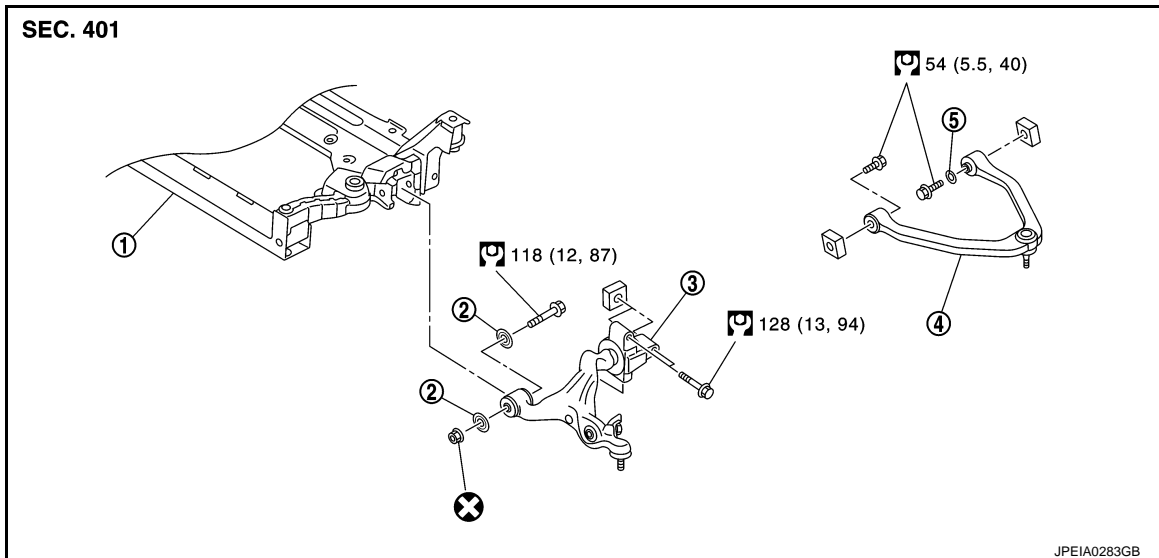

- |                            |                    |                    |
|----------------------------|--------------------|--------------------|
| 1. Front suspension member | 2. Stopper bushing | 3. Transverse link |
| 4. Upper link              | 5. Stopper rubber  |                    |

Refer to [GI-4, "Components"](#) for symbols in the figure.

## Removal and Installation

INFOID:000000007455289

### REMOVAL

1. Remove tires with power tool.
2. Remove under cover with power tool.
3. Remove shock absorber. Refer to [FSU-28, "Exploded View"](#).
4. Remove front crossbar. Refer to [FSU-37, "Exploded View"](#).
5. Remove steering outer socket from steering knuckle. Refer to [ST-34, "AWD : Exploded View"](#).
6. Remove transverse link from steering knuckle.
7. Set suitable jack under transverse link.
8. Remove transverse link and stopper bushing.

### INSTALLATION

Note the following, and install in the reverse order of removal.

- Never tap on the ball joint cap of the stabilizer connecting rod with a hammer or a similar item when inserting the stabilizer connecting rod into the transverse link.
- Perform final tightening of bolts and nuts at the front suspension member installation and shock absorber lower side (rubber bushing), under unladen conditions with tires on level ground.

## Inspection

INFOID:000000007455290

### INSPECTION AFTER REMOVAL

#### Appearance

Check the following items, and replace the part if necessary.

- Transverse link and bushing for deformation, cracks or damage.
- Ball joint boot for cracks or other damage, and also for grease leakage.

#### Ball Joint Inspection

Manually move ball stud to confirm it moves smoothly with no binding.

#### Swing Torque Inspection



# TRANSVERSE LINK

[AWD]

## < REMOVAL AND INSTALLATION >

1. Move the ball stud at least ten times by hand to check for smooth movement.
2. Hook a spring balance (A) at cotter pin mounting hole. Confirm spring balance measurement value is within specifications when ball stud begins moving.

**Swing torque** :Refer to [FSU-39, "Ball Joint"](#).

- If swing torque exceeds standard range, replace transverse link assembly.

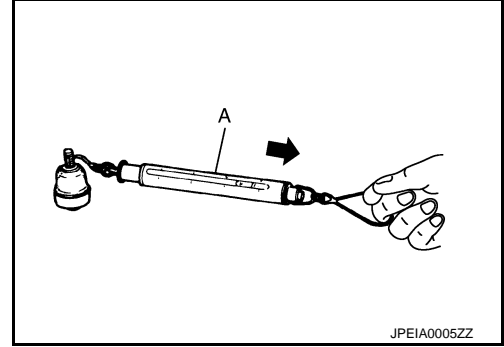

### Rotating Torque Inspection

1. Move the ball stud at least ten times by hand to check for smooth movement.
2. Attach mounting nut to ball stud. Make sure that rotating torque is within specifications with a preload gauge (A) [SST: 3127S000 (J-25765-A)].

**Rotating torque** : Refer to [FSU-39, "Ball Joint"](#).

- If rotating torque exceeds standard range, replace transverse link assembly.

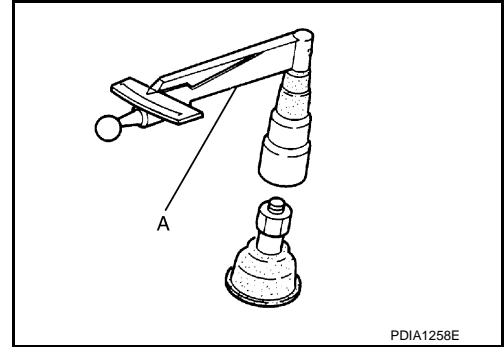

### Axial End Play Inspection

1. Move the ball stud at least ten times by hand to check for smooth movement.
2. Move tip of ball stud in axial direction to check for looseness.

**Axial end play** :Refer to [FSU-39, "Ball Joint"](#).

- If axial end play exceeds standard range, replace transverse link assembly.

## INSPECTION AFTER INSTALLATION

1. Check wheel sensor harness for proper connection. Refer to [BRC-121, "FRONT WHEEL SENSOR : Exploded View"](#).
2. Check wheel alignment. Refer to [FSU-26, "Inspection"](#).

# UPPER LINK

< REMOVAL AND INSTALLATION >

[AWD]

## UPPER LINK

### Exploded View

INFOID:000000007455291

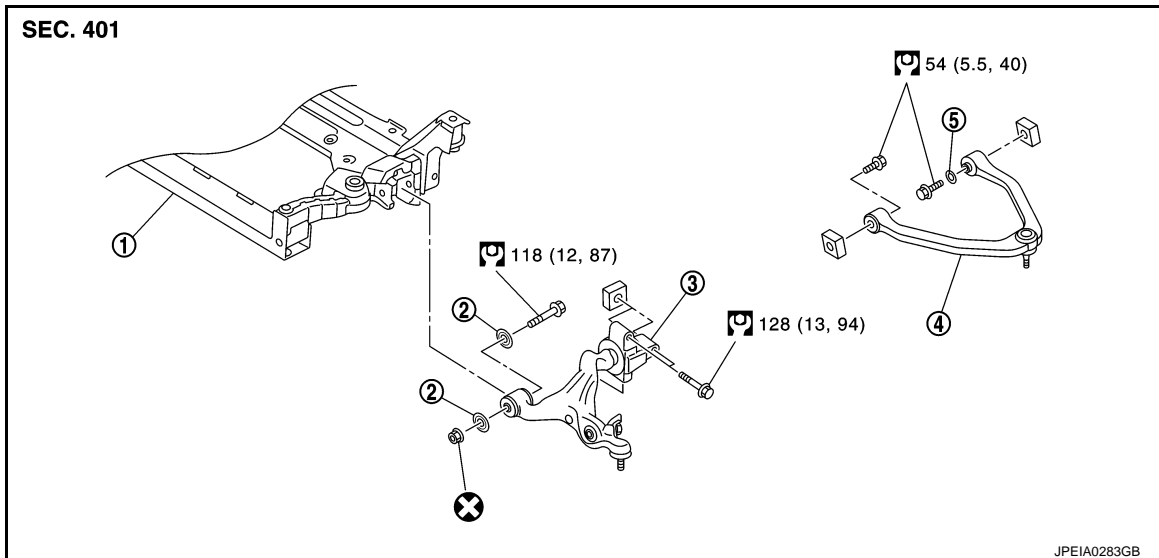

- |                            |                    |                    |
|----------------------------|--------------------|--------------------|
| 1. Front suspension member | 2. Stopper bushing | 3. Transverse link |
| 4. Upper link              | 5. Stopper rubber  |                    |

Refer to [GI-4, "Components"](#) for symbols in the figure.

## Removal and Installation

INFOID:000000007455292

### REMOVAL

1. Remove tires from with power tool.
2. Remove shock absorber. Refer to [FSU-28, "Exploded View"](#).
3. Remove upper link from steering knuckle.
4. Remove upper link and stopper rubber.

### INSTALLATION

Note the following, and install in the reverse order of removal.

- Perform final tightening of bolts and nuts at the vehicle installation position (rubber bushing), under unladen conditions with tires on level ground.

## Inspection

INFOID:000000007455293

### INSPECTION AFTER REMOVAL

#### Appearance

Check the following items, and replace the part if necessary.

- Upper link and bushing for deformation, cracks or damage.
- Ball joint boot for cracks or other damage, and also for grease leakage.

#### Ball Joint Inspection

Manually move ball stud to confirm it moves smoothly with no binding.

#### Swing Torque Inspection

1. Move the ball stud at least ten times by hand to check for smooth movement.

## UPPER LINK

### < REMOVAL AND INSTALLATION >

[AWD]

- Hook a spring balance (A) at cutout on ball stud. Confirm spring balance measurement value is within specifications when ball stud begins moving.

**Swing torque** : Refer to [FSU-39, "Ball Joint"](#).

- If swing torque exceeds standard range, replace upper link assembly.

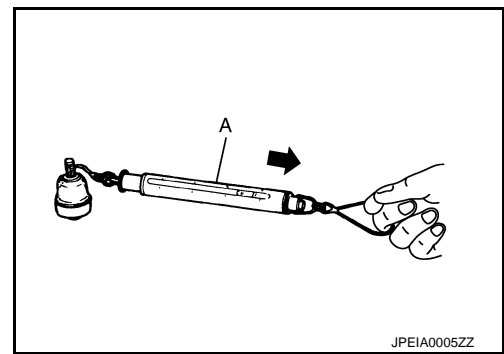

### Axial End Play Inspection

- Move the ball stud at least ten times by hand to check for smooth movement.
- Move tip of ball stud in axial direction to check for looseness.

**Axial end play** : Refer to [FSU-39, "Ball Joint"](#).

- If axial end play exceeds standard range, replace upper link assembly.

### INSPECTION AFTER INSTALLATION

- Check wheel sensor harness for proper connection. Refer to [BRC-121, "FRONT WHEEL SENSOR : Exploded View"](#).
- Check wheel alignment. Refer to [FSU-26, "Inspection"](#).

A  
B  
C  
D

FSU

F  
G  
H  
I  
J  
K  
L  
M  
N  
O  
P

# FRONT STABILIZER

< REMOVAL AND INSTALLATION >

[AWD]

## FRONT STABILIZER

Exploded View

INFOID:000000007455294

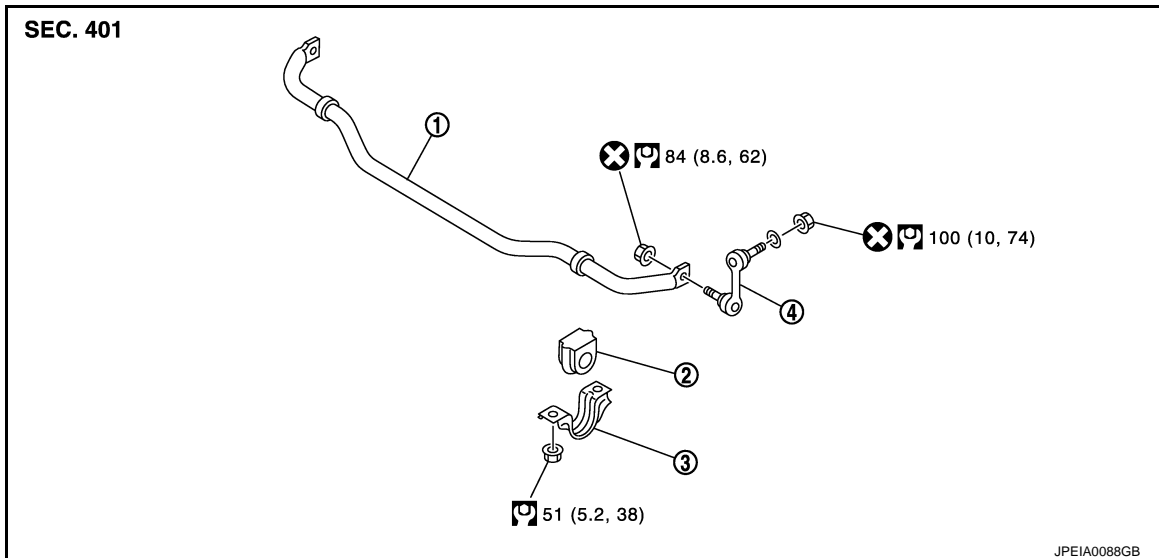

1. Stabilizer bar
2. Stabilizer bushing
3. Stabilizer clamp
4. Stabilizer connecting rod

Refer to [GI-4, "Components"](#) for symbols in the figure.

## Removal and Installation

INFOID:000000007455295

### REMOVAL

1. Remove tires with power tool.
2. Remove under cover with power tool.
3. Remove stabilizer connecting rods.  
**CAUTION:**  
**Apply a matching mark to identify the installation position.**
4. Remove stabilizer clamps and stabilizer bushings.
5. Remove stabilizer bar.

### INSTALLATION

Note the following, and install in the reverse order of removal.

- Check the matching mark when installing.
- Tighten the mounting nut to the specified torque while holding a hexagonal part of stabilizer connecting rod side.

### Inspection

INFOID:000000007455296

### INSPECTION AFTER REMOVAL

Check stabilizer bar, stabilizer connecting rod, stabilizer bushing and stabilizer clamp for deformation, cracks or damage. Replace it if necessary.

# FRONT SUSPENSION MEMBER

< REMOVAL AND INSTALLATION >

[AWD]

## FRONT SUSPENSION MEMBER

### Exploded View

INFOID:000000007455297

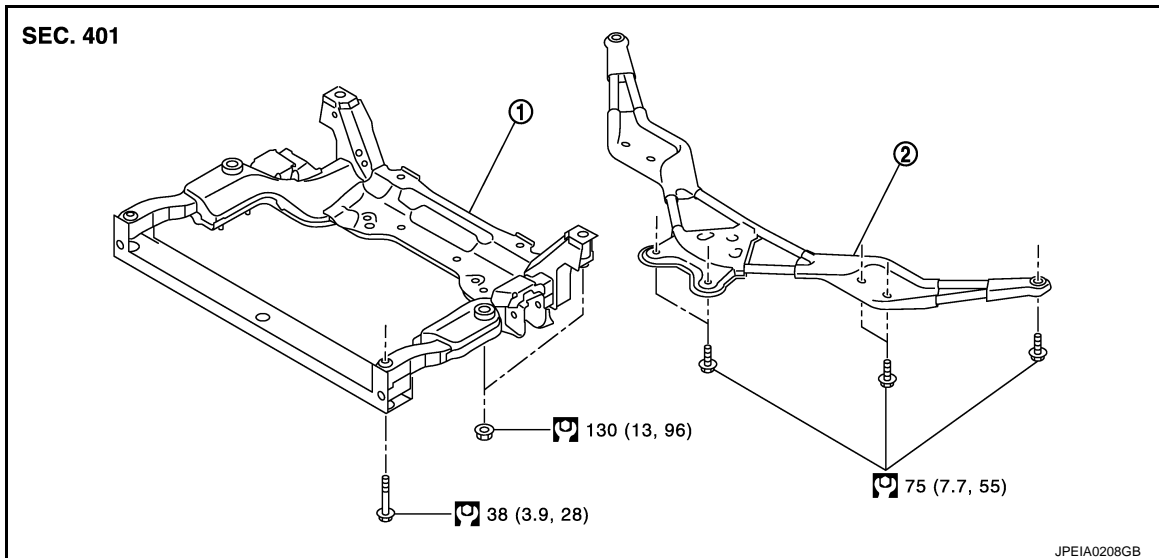

1. Front suspension member
2. Front cross bar

Refer to [GI-4, "Components"](#) for symbols in the figure.

### Removal and Installation

INFOID:000000007455298

#### REMOVAL

1. Remove tires with power tool.
2. Remove under cover with power tool.
3. Remove front cross bar with power tool.
4. Separate steering gear assembly and lower joint. Refer to [ST-34, "AWD : Exploded View"](#) and [ST-23, "Exploded View"](#).
5. Remove steering outer sockets from steering knuckles. Refer to [ST-34, "AWD : Exploded View"](#).
6. Remove wheel sensors and sensor harness from steering knuckles. Refer to [BRC-121, "FRONT WHEEL SENSOR : Exploded View"](#).
7. Remove shock absorbers from transverse links. Refer to [FSU-28, "Exploded View"](#).
8. Remove stabilizer connecting rods and stabilizer bar. Refer to [FSU-36, "Exploded View"](#).
9. Install engine slinger, and then hoist engine. Refer to [EM-84, "AWD : Removal and Installation"](#).
10. Remove transverse links from front suspension member. Refer to [FSU-32, "Exploded View"](#).
11. Remove steering hydraulic piping bracket and steering gear from front suspension member. Refer to [ST-52, "AWD : Exploded View"](#).
12. Set suitable jack front suspension member.
13. Remove mounting nuts between engine mounting insulator and from suspension member. Refer to [EM-84, "AWD : Exploded View"](#).
14. Remove mounting bolts and nuts of front suspension member with power tool.
15. Gradually lower jack to remove front suspension assembly from vehicle.

#### INSTALLATION

Note the following, and install in the reverse order of removal.

- Perform final tightening of bolts and nut at the vehicle installation position (rubber bushing), under unladen condition with tires on level ground.

# FRONT SUSPENSION MEMBER

< REMOVAL AND INSTALLATION >

[AWD]

## Inspection

INFOID:000000007455299

### INSPECTION AFTER REMOVAL

Check the front suspension member for significant deformation, cracks, or damages. Replace if necessary.

### INSPECTION AFTER INSTALLATION

1. Check wheel sensor harness for proper connection. Refer to [BRC-121, "FRONT WHEEL SENSOR : Exploded View"](#).
2. Check wheel alignment. Refer to [FSU-26, "Inspection"](#).

# SERVICE DATA AND SPECIFICATIONS (SDS)

< SERVICE DATA AND SPECIFICATIONS (SDS)

[AWD]

## SERVICE DATA AND SPECIFICATIONS (SDS)

### SERVICE DATA AND SPECIFICATIONS (SDS)

#### Wheel Alignment

INFOID:0000000007455300

Item		Standard	
Camber Degree minute (Decimal degree)	Minimum	-1° 05' (-1.08°)	
	Nominal	-0° 20' (-0.33°)	
	Maximum	0° 25' (0.41°)	
	Left and right difference	0° 33' (0.55°) or less	
Caster Degree minute (Decimal degree)	Minimum	3° 25' (3.42°)	
	Nominal	4° 10' (4.17°)	
	Maximum	4° 55' (4.91°)	
	Left and right difference	0° 39' (0.65°) or less	
Kingpin inclination Degree minute (Decimal degree)	Minimum	6° 35' (6.59°)	
	Nominal	7° 20' (7.33°)	
	Maximum	8° 05' (8.08°)	
Toe-in	Total toe-in Distance	Minimum	Out 1 mm (Out 0.03 in)
		Nominal	In 1 mm (In 0.04 in)
		Maximum	In 3 mm (In 0.11 in)
	Total toe-angle Degree minute (Decimal degree)	Minimum	Out 0° 04' 48" (Out 0.08°)
		Nominal	In 0° 04' 48" (In 0.08°)
		Maximum	In 0° 14' 24" (In 0.24°)

Measure value under unladen\* conditions.

\*Fuel, engine coolant and lubricant are full. Spare tire, jack, hand tools and mats are in designated positions.

#### Ball Joint

INFOID:0000000007455301

Item		Standard
Swing torque	Transverse link	0.5 – 3.6 N·m (0.06 – 0.36 kg·m, 5 – 31 in-lb)
	Upper link	0 – 2.0 N·m (0 – 0.20 kg·m, 0 – 17 in-lb)
Measurement on spring balance	Transverse link	7.8 – 56.3 N (0.8 – 5.7 kg, 1.8 – 12.6 lb)
	Upper link	0 – 61.5 N (0 – 6.2 kg, 0 – 13.8 lb)
Rotating torque	Transverse link	0.5 – 3.9 N·m (0.06 – 0.39 kg·m, 5 – 34 in-lb)
Axial end play		0 mm (0 in)

#### Wheelarch Height

INFOID:0000000007455302

Item	Standard	
Wheel size	18 inch	19 inch
Front (Hf)	747 mm (29.41 in)	748 mm (29.45 in)

# SERVICE DATA AND SPECIFICATIONS (SDS)

< SERVICE DATA AND SPECIFICATIONS (SDS)

[AWD]

Item	Standard	
Wheel size	18 inch	19 inch
Rear (Hr)	762 mm (30.00 in)	764 mm (30.08 in)

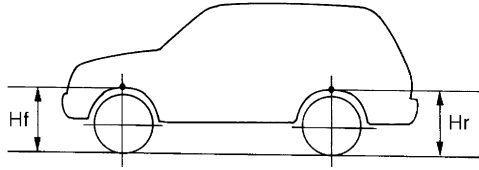

SFA746B

Measure value under unladen\* conditions.

\*: Fuel, engine coolant and lubricant are full. Spare tire, jack, hand tools and mats are in designated positions.