

SECTION **IP**
INSTRUMENT PANEL

A
B
C
D
E
F
G
H
I
IP
K
L
M
N
O
P

CONTENTS

PRECAUTION	2	SYMPTOM DIAGNOSIS	6
PRECAUTIONS	2	SQUEAK AND RATTLE TROUBLE DIAG- NOSES	6
Precaution for Supplemental Restraint System (SRS) "AIR BAG" and "SEAT BELT PRE-TEN- SIONER"	2	Work Flow	6
Precautions Necessary for Steering Wheel Rota- tion After Battery Disconnection	2	Inspection Procedure	8
Precaution	3	Diagnostic Worksheet	10
PREPARATION	4	REMOVAL AND INSTALLATION	12
PREPARATION	4	INSTRUMENT PANEL ASSEMBLY	12
Special Service Tools	4	Exploded View	12
Commercial Service Tools	4	Removal and Installation	13
CLIP LIST	5	CENTER CONSOLE ASSEMBLY	22
Clip List	5	Exploded View	22
		Removal and Installation	23
		Disassembly and Assembly	24

PRECAUTIONS

< PRECAUTION >

PRECAUTION

PRECAUTIONS

Precaution for Supplemental Restraint System (SRS) "AIR BAG" and "SEAT BELT PRE-TENSIONER"

INFOID:000000007793426

The Supplemental Restraint System such as "AIR BAG" and "SEAT BELT PRE-TENSIONER", used along with a front seat belt, helps to reduce the risk or severity of injury to the driver and front passenger for certain types of collision. This system includes seat belt switch inputs and dual stage front air bag modules. The SRS system uses the seat belt switches to determine the front air bag deployment, and may only deploy one front air bag, depending on the severity of a collision and whether the front occupants are belted or unbelted. Information necessary to service the system safely is included in the "SRS AIR BAG" and "SEAT BELT" of this Service Manual.

WARNING:

Always observe the following items for preventing accidental activation.

- To avoid rendering the SRS inoperative, which could increase the risk of personal injury or death in the event of a collision that would result in air bag inflation, all maintenance must be performed by an authorized NISSAN/INFINITI dealer.
- Improper maintenance, including incorrect removal and installation of the SRS, can lead to personal injury caused by unintentional activation of the system. For removal of Spiral Cable and Air Bag Module, see "SRS AIR BAG".
- Never use electrical test equipment on any circuit related to the SRS unless instructed to in this Service Manual. SRS wiring harnesses can be identified by yellow and/or orange harnesses or harness connectors.

PRECAUTIONS WHEN USING POWER TOOLS (AIR OR ELECTRIC) AND HAMMERS

WARNING:

Always observe the following items for preventing accidental activation.

- When working near the Air Bag Diagnosis Sensor Unit or other Air Bag System sensors with the ignition ON or engine running, never use air or electric power tools or strike near the sensor(s) with a hammer. Heavy vibration could activate the sensor(s) and deploy the air bag(s), possibly causing serious injury.
- When using air or electric power tools or hammers, always switch the ignition OFF, disconnect the battery, and wait at least 3 minutes before performing any service.

Precautions Necessary for Steering Wheel Rotation After Battery Disconnection

INFOID:000000007793427

CAUTION:

Comply with the following cautions to prevent any error and malfunction.

- Before removing and installing any control units, first turn the ignition switch to the LOCK position, then disconnect both battery cables.
- After finishing work, confirm that all control unit connectors are connected properly, then re-connect both battery cables.
- Always use CONSULT to perform self-diagnosis as a part of each function inspection after finishing work. If a DTC is detected, perform trouble diagnosis according to self-diagnosis results.

For vehicle with steering lock unit, if the battery is disconnected or discharged, the steering wheel will lock and cannot be turned.

If turning the steering wheel is required with the battery disconnected or discharged, follow the operation procedure below before starting the repair operation.

OPERATION PROCEDURE

1. Connect both battery cables.

NOTE:

Supply power using jumper cables if battery is discharged.

2. Turn the ignition switch to ACC position.
(At this time, the steering lock will be released.)
3. Disconnect both battery cables. The steering lock will remain released with both battery cables disconnected and the steering wheel can be turned.

PRECAUTIONS

< PRECAUTION >

4. Perform the necessary repair operation.
5. When the repair work is completed, re-connect both battery cables. With the brake pedal released, turn the ignition switch from ACC position to ON position, then to LOCK position. (The steering wheel will lock when the ignition switch is turned to LOCK position.)
6. Perform self-diagnosis check of all control units using CONSULT.

Precaution

INFOID:000000007793428

- Disconnect battery negative terminal in advance.
- Disconnect air bag system line in advance.
- Never tamper with or force air bag lid open, as this may adversely affect air bag performance.
- Be careful not to scratch pad and other parts.
- When removing or disassembling any part, be careful not to damage or deform it. Protect parts, that may get in the way with a shop cloth.
- When removing parts with a screwdriver or other tool, cover the tool surface with vinyl tape to protect parts.
- Keep removed parts protected with a shop cloth.
- If a clip is deformed or damaged, replace it.
- If an un reusable part is removed, replace it with a new one.
- Tighten bolts and nuts firmly to the specified torque.
- After reassembly is complete, check that each part functions correctly.
- Remove stains via the following procedure.

Water-soluble stains:

Dip a soft cloth in warm water, and then squeeze it tightly. After wiping off the stain, wipe with a soft dry cloth.

Oil stain:

Dissolve a synthetic detergent in warm water (density of 2 to 3%), dip the cloth, then wipe off the stain with the cloth. Next, dip the cloth in fresh water and squeeze it tightly. Then wipe off the detergent completely. Then wipe the area with a soft dry cloth.

- Never use any organic solvent, such as thinner or benzine.

A
B
C
D
E
F
G
H
I
K
L
M
N
O
P



PREPARATION

< PREPARATION >

PREPARATION

PREPARATION

Special Service Tools

INFOID:000000007793482

The actual shapes of Kent-Moore tools may differ from those of special service tools illustrated here.

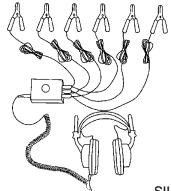
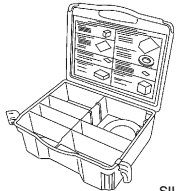
Tool number (Kent-Moore No.) Tool name	Description
<p>(J-39570) Chassis ear</p>  <p>SIIA0993E</p>	<p>Locates the noise</p>
<p>(J-43980) NISSAN Squeak and Rattle Kit</p>  <p>SIIA0994E</p>	<p>Repairs the cause of noise</p>

Commercial Service Tools

INFOID:000000007793483

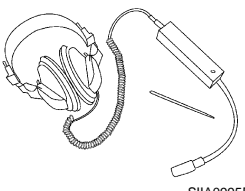
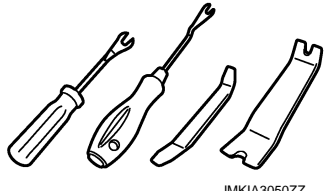
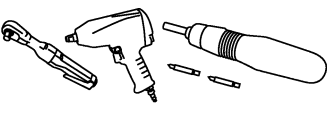
Tool name	Description
<p>Engine ear</p>  <p>SIIA0995E</p>	<p>Locates the noise</p>
<p>Remover tool</p>  <p>JMKIA3050ZZ</p>	<p>Removes clips, pawls, and metal clips</p>
<p>Power tool</p>  <p>PIIB1407E</p>	

CLIP LIST

< PREPARATION >

CLIP LIST

Clip List

INFOID:000000007793484

Shapes	Removal & Installation	Shapes	Removal & Installation
	<p>Removal: Remove by bending up with flat-bladed screwdrivers or clip remover.</p>		<p>Removal: Finisher Clip A Flat-bladed screwdriver Clip B</p>
	<p>Removal: Remove with a clip remover.</p>		<p>Removal: Flat-bladed screwdriver Finisher Body panel Clip A Clip B (Grommet)</p>
	<p>Removal: Push center pin to catching position. (Do not remove center pin by hitting it.)</p> <p>Installation: Push</p>		<p>Removal: Holder portion of clip must be spread out to remove rod.</p>
	<p>Removal: Remove by bending up with flat-bladed screwdrivers or clip remover.</p> <p>Clip Finisher</p>		<p>Removal: 1. Screw out with a Phillips screwdriver. 2. Remove female portion with flat-bladed screwdriver.</p>
	<p>Removal:</p>		<p>Removal: Rotate 45° to remove.</p> <p>Installation:</p>
	<p>Removal:</p>		<p>Removal:</p>

JMJIA3734GB

A
B
C
D
E
F
G
H
I
IP
K
L
M
N
O
P

SQUEAK AND RATTLE TROUBLE DIAGNOSES

< SYMPTOM DIAGNOSIS >

SYMPTOM DIAGNOSIS

SQUEAK AND RATTLE TROUBLE DIAGNOSES

Work Flow

INFOID:000000007459369

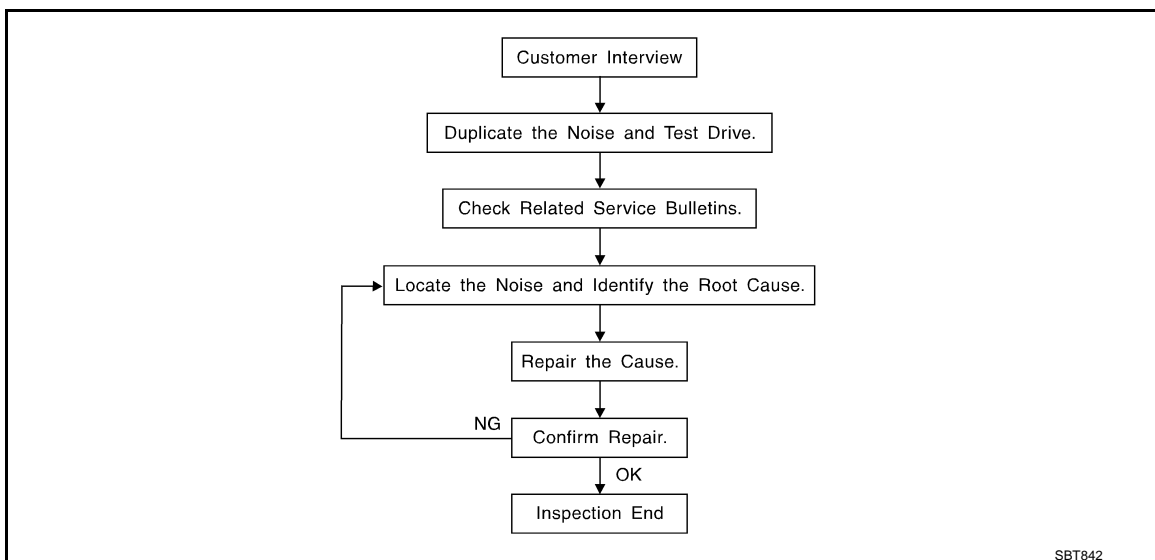

CUSTOMER INTERVIEW

Interview the customer if possible, to determine the conditions that exist when the noise occurs. Use the Diagnostic Worksheet during the interview to document the facts and conditions when the noise occurs and any customer comments. Refer to [IP-10, "Diagnostic Worksheet"](#). This information is necessary to duplicate the conditions that exist when the noise occurs.

- The customer may not be able to provide a detailed description or the location of the noise. Attempt to obtain all the facts and conditions that exist when the noise occurs (or does not occur).
- If there is more than one noise in the vehicle, perform a diagnosis and repair the noise that the customer is concerned about. This can be accomplished by performing a test drive with the customer.
- After identifying the type of noise, isolate the noise in terms of its characteristics. The noise characteristics are provided so that the customer, service adviser, and technician use the same language when describing the noise.
- Squeak – (Like tennis shoes on a clean floor)
Squeak characteristics include the light contact / fast movement / brought on by road conditions / hard surfaces = high-pitched noise / softer surfaces = low-pitched noises / edge to surface = chirping
- Creak – (Like walking on an old wooden floor)
Creak characteristics include firm contact / slow movement/twisting with a rotational movement / pitch dependent on materials / often brought on by activity.
- Rattle – (Like shaking a baby rattle)
Rattle characteristics include fast repeated contact / vibration or similar movement / loose parts/missing clip or fastener / incorrect clearance.
- Knock – (Like a knock on a door)
Knock characteristics include hollow sounds / sometimes repeating / often brought on by driver action.
- Tick – (Like a clock second hand)
Tick characteristics include gentle contacting of light materials / loose components / can be caused by driver action or road conditions.
- Thump – (Heavy, muffled knock noise)
Thump characteristics include softer knock / dull sounds often brought on by activity.
- Buzz – (Like a bumblebee)
Buzz characteristics include high frequency rattle / firm contact.
- Often the degree of acceptable noise level varies depending upon the person. A noise that a technician may judge as acceptable may be very irritating to a customer.
- Weather conditions, especially humidity and temperature, may have a great effect on noise level.

DUPLICATE THE NOISE AND TEST DRIVE

SQUEAK AND RATTLE TROUBLE DIAGNOSES

< SYMPTOM DIAGNOSIS >

If possible, drive the vehicle with the customer until the noise is duplicated. Note any additional information on the Diagnostic Worksheet regarding the conditions or location of the noise. This information can be used to duplicate the same conditions when the repair is reconfirmed.

If the noise can be duplicated easily during the test drive, to help identify the source of the noise, try to duplicate the noise with the vehicle stopped by doing one or all of the following items:

- 1) Close a door.
 - 2) Tap or push/pull around the area where the noise appears to be coming from.
 - 3) Rev the engine.
 - 4) Use a floor jack to recreate vehicle "twist".
 - 5) At idle, apply engine load (electrical load, half-clutch on M/T models, drive position on A/T models).
 - 6) Raise the vehicle on a hoist and hit a tire with a rubber hammer.
- Drive the vehicle and attempt to duplicate the conditions the customer states exist when the noise occurs.
 - If it is difficult to duplicate the noise, drive the vehicle slowly on an undulating or rough road to stress the vehicle body.

CHECK RELATED SERVICE BULLETINS

After verifying the customer concern or symptom, check ASIST for Technical Service Bulletins (TSBs) related to the concern or symptom.

If a TSB relates to the symptom, follow the procedure to repair the noise.

LOCATE THE NOISE AND IDENTIFY THE ROOT CAUSE

1. Narrow down the noise to a general area. To help pinpoint the source of the noise, use a listening tool (Chassis ear: J-39570, engine ear, and mechanics stethoscope).
2. Narrow down the noise to a more specific area and identify the cause of the noise by:
 - Removing the component(s) in the area that is / are suspected to be the cause of the noise. Do not use too much force when removing clips and fasteners, otherwise clips and fasteners can be broken or lost during the repair, resulting in the creation of new noise.
 - Tapping or pushing/pulling the component(s) that is / are suspected to be the cause of the noise. Do not tap or push/pull the component(s) with excessive force, otherwise the noise is eliminated only temporarily.
 - Feeling for a vibration by hand by touching the component(s) that is / are suspected to be the cause of the noise.
 - Placing a piece of paper between components that are suspected to be the cause of the noise.
 - Looking for loose components and contact marks.
Refer to [IP-8, "Inspection Procedure"](#).

REPAIR THE CAUSE

- If the cause is a loose component, tighten the component securely.
- If the cause is insufficient clearance between components:
 - Separate components by repositioning or loosening and retightening the components, if possible.
 - Insulate components with a suitable insulator such as urethane pads, foam blocks, felt cloth tape, or urethane tape. A NISSAN Squeak and Rattle Kit (J-43980) is available through the authorized NISSAN Parts Department.

CAUTION:

Never use excessive force as many components are constructed of plastic and may be damaged.

NOTE:

Always check with the Parts Department for the latest parts information.

The following materials are contained in the NISSAN Squeak and Rattle Kit (J-43980). Each item can be ordered separately as needed.

URETHANE PADS [1.5 mm (0.059 in) thick]

Insulates connectors, harness, etc.

- 76268-9E005: 100 × 135 mm (3.937 × 5.315 in)
- 76884-71L01: 60 × 85 mm (2.362 × 3.346 in)
- 76884-71L02: 15 × 25 mm (0.591 × 0.984 in)

INSULATOR (Foam blocks)

Insulates components from contact. Can be used to fill space behind a panel.

- 73982-9E000: 45 mm (1.772 in) thick, 50 × 50 mm (1.969 × 1.969 in)
- 73982-50Y00: 10 mm (0.394 in) thick, 50 × 50 mm (1.969 × 1.969 in)

INSULATOR (Light foam block)

80845-71L00: 30 mm (1.18 in) thick, 30 × 50 mm (1.181 × 1.969 in)

FELT CLOTHTAPE

SQUEAK AND RATTLE TROUBLE DIAGNOSES

< SYMPTOM DIAGNOSIS >

Used to insulate where movement does not occur. Ideal for instrument panel applications.

- 68370-4B000: 15 × 25 mm (0.591 × 0.984 in) pad
- 68239-13E00: 5 mm (0.197 in) wide tape roll

The following materials, not found in the kit, can also be used to repair squeaks and rattles.

UHMW (TEFLON) TAPE

Insulates where slight movement is present. Ideal for instrument panel applications.

SILICONE GREASE

Used in place of UHMW tape that is visible or does not fit. Only lasts a few months.

SILICONE SPRAY

Used when grease cannot be applied.

DUCT TAPE

Used to eliminate movement.

CONFIRM THE REPAIR

After repair is complete, test drive the vehicle to confirm that the cause of noise is repaired by test driving the vehicle. Operate the vehicle under the same conditions as when the noise originally occurred. Refer to the notes on the Diagnostic Worksheet.

Inspection Procedure

INFOID:000000007459370

Refer to Table of Contents for specific component removal and installation information.

INSTRUMENT PANEL

Most incidents are caused by contact and movement between:

1. The cluster lid A and instrument panel
2. Acrylic lens and combination meter housing
3. Instrument panel to front pillar garnish
4. Instrument panel to windshield
5. Instrument panel mounting pins
6. Wiring harnesses behind the combination meter
7. A/C defroster duct and duct joint

These incidents can usually be located by tapping or moving the components to duplicate the noise or by pressing on the components while driving to stop the noise. Most of these incidents can be repaired by applying felt cloth tape or silicon spray (in hard to reach areas). Urethane pads can be used to insulate wiring harness.

CAUTION:

Never use silicone spray to isolate a squeak or rattle. If the area is saturated with silicone, the recheck of repair becomes impossible.

CENTER CONSOLE

Components to check include:

1. Shifter assembly cover to finisher
2. A/C control unit and cluster lid C
3. Wiring harnesses behind audio and A/C control unit

The instrument panel repair and isolation procedures also apply to the center console.

DOORS

Check the following items:

1. Finisher and inner panel making a slapping noise
2. Inside handle escutcheon connection to door finisher
3. Wiring harnesses tapping
4. Door striker out of alignment causing a popping noise on starts and stops

Tapping, moving the components, or pressing on them while driving to duplicate the conditions can isolate many of these incidents. The areas can usually be insulated with felt cloth tape or insulator foam blocks from the NISSAN Squeak and Rattle Kit (J-43980) to repair the noise.

TRUNK

Trunk noises are often caused by a loose jack or loose items put into the trunk by the customer.

In addition check for the following items:

SQUEAK AND RATTLE TROUBLE DIAGNOSES

< SYMPTOM DIAGNOSIS >

1. Trunk lid dumpers out of adjustment
2. Trunk lid striker out of adjustment
3. Trunk lid torsion bars knocking together
4. A loose license plate or bracket

Most of these incidents can be repaired by adjusting, securing, or insulating the item(s) or component(s) causing the noise.

SUNROOF/HEADLINING

Noises in the sunroof / headlining area can often be traced to one of the following items:

1. Sunroof lid, rail, linkage, or seals making a rattle or light knocking noise
2. Sunvisor shaft shaking in the holder
3. Front or rear windshield touching headlining and squeaking

Again, pressing on the components to stop the noise while duplicating the conditions can isolate most of these incidents. Repairs usually consist of insulating with felt cloth tape.

SEATS

When isolating seat noise it is important to note the position the seat is in and the load placed on the seat when the noise occurs. These conditions should be duplicated when verifying and isolating the cause of the noise.

Causes of seat noise include:

1. Headrest rods and holder
2. A squeak between the seat pad cushion and frame
3. The rear seatback lock and bracket

These noises can be isolated by moving or pressing on the suspected components while duplicating the conditions under which the noise occurs. Most of these incidents can be repaired by repositioning the component or applying urethane tape to the contact area.

UNDERHOOD

Some interior noise may be caused by components under the hood or on the engine wall. The noise is then transmitted into the passenger compartment.

Causes of transmitted underhood noise include:

1. Any component mounted to the engine wall
2. Components that pass through the engine wall
3. Engine wall mounts and connectors
4. Loose radiator mounting pins
5. Hood bumpers out of adjustment
6. Hood striker out of adjustment

These noises can be difficult to isolate since they cannot be reached from the interior of the vehicle. The best method is to secure, move, or insulate one component at a time and test drive the vehicle. Also, engine RPM or load can be changed to isolate the noise. Repairs can usually be made by moving, adjusting, securing, or insulating the component causing the noise.

A
B
C
D
E
F
G
H
I
IP
K
L
M
N
O
P

SQUEAK AND RATTLE TROUBLE DIAGNOSES

< SYMPTOM DIAGNOSIS >

Diagnostic Worksheet

INFOID:000000007459371



SQUEAK & RATTLE DIAGNOSTIC WORKSHEET

Dear Infiniti Customer:

We are concerned about your satisfaction with your Infiniti vehicle. Repairing a squeak or rattle sometimes can be very difficult. To help us fix your Infiniti right the first time, please take a moment to note the area of the vehicle where the squeak or rattle occurs and under what conditions. You may be asked to take a test drive with a service consultant or technician to ensure we confirm the noise you are hearing.

I. WHERE DOES THE NOISE COME FROM? (circle the area of the vehicle)

The illustrations are for reference only, and may not reflect the actual configuration of your vehicle.

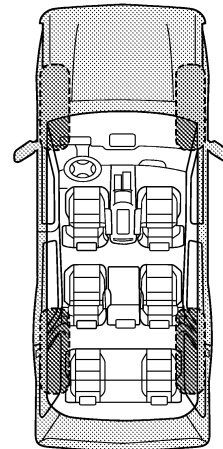
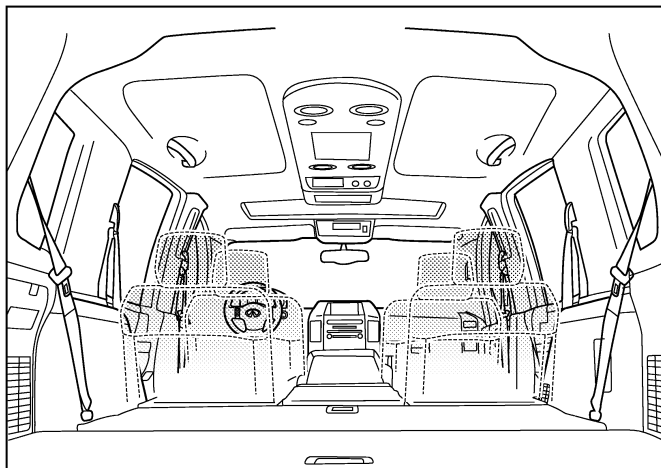
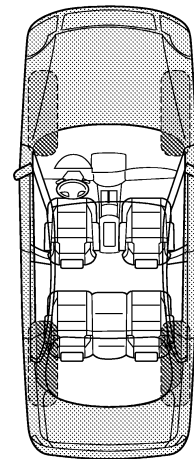
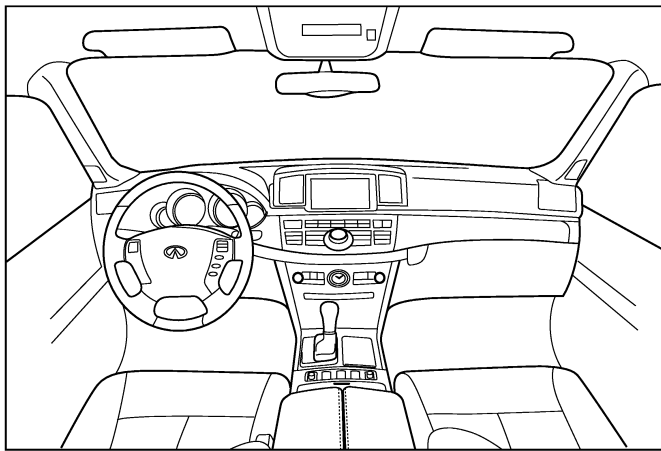

Continue to page 2 of the worksheet and briefly describe the location of the noise or rattle. In addition, please indicate the conditions which are present when the noise occurs.

PIIB8741E

SQUEAK AND RATTLE TROUBLE DIAGNOSES

< SYMPTOM DIAGNOSIS >

SQUEAK & RATTLE DIAGNOSTIC WORKSHEET - page 2

Briefly describe the location where the noise occurs:

II. WHEN DOES IT OCCUR? (please check the boxes that apply)

- | | |
|---|--|
| <input type="checkbox"/> anytime | <input type="checkbox"/> after sitting out in the rain |
| <input type="checkbox"/> 1st time in the morning | <input type="checkbox"/> when it is raining or wet |
| <input type="checkbox"/> only when it is cold outside | <input type="checkbox"/> dry or dusty conditions |
| <input type="checkbox"/> only when it is hot outside | <input type="checkbox"/> other: |

III. WHEN DRIVING:

- through driveways
- over rough roads
- over speed bumps
- only about ____ mph
- on acceleration
- coming to a stop
- on turns: left, right or either (circle)
- with passengers or cargo
- other: _____
- after driving ____ miles or ____ minutes

IV. WHAT TYPE OF NOISE

- squeak (like tennis shoes on a clean floor)
- creak (like walking on an old wooden floor)
- rattle (like shaking a baby rattle)
- knock (like a knock at the door)
- tick (like a clock second hand)
- thump (heavy, muffled knock noise)
- buzz (like a bumble bee)

TO BE COMPLETED BY DEALERSHIP PERSONNEL

Test Drive Notes:

	YES	NO	Initials of person performing
Vehicle test driven with customer	<input type="checkbox"/>	<input type="checkbox"/>	_____
- Noise verified on test drive	<input type="checkbox"/>	<input type="checkbox"/>	_____
- Noise source located and repaired	<input type="checkbox"/>	<input type="checkbox"/>	_____
- Follow up test drive performed to confirm repair	<input type="checkbox"/>	<input type="checkbox"/>	_____

VIN: _____ Customer Name: _____
W.O.# _____ Date: _____

This form must be attached to Work Order

PIIB8742E

A
B
C
D
E
F
G
H
I
IP
K
L
M
N
O
P

INSTRUMENT PANEL ASSEMBLY

< REMOVAL AND INSTALLATION >

- | | | |
|---------------------------------|-------------------------------|-------------------------------|
| 16. Steering column mask | 17. Instrument side panel LH | 18. Instrument side panel RH |
| 19. Glove box assembly | 20. Instrument lower panel RH | 21. Instrument lower cover |
| 22. Instrument side finisher RH | 23. Front squawker RH | 24. Speaker grille RH |
| 25. Center speaker grille | 26. Instrument panel assembly | 27. Center speaker |
| 28. Side ventilator grille LH | 29. Center ventilator grille | 30. Side ventilator grille RH |
| 31. Display unit | 32. Cluster lid D | 33. Glove box dumper |
| 34. AV C/U (audio unit) | 35. Cluster lid C | |

Removal and Installation

INFOID:000000007459373

WORK STEP

When removing instrument panel assembly, combination meter, AV control unit, and center console assembly take steps in the order shown by the number below.

PARTS	INSTRUMENT PANEL ASSEMBLY	COMBINATION METER	AV CONTROL UNIT	CENTER CONSOLE ASSEMBLY
Console finisher assembly	[1]		[1]	[1]
Console sub harness connectors	[2]			[2]
Center console assembly fixing screws	[3]			[3]
Console center finisher	[4]			[4]
Console rear finisher	[5]			[5]
Rear ventilator duct 2	[6]			[6]
Center console assembly fixing screws	[7]			[7]
Center console assembly	[8]			[8]
Instrument side finisher LH	[9]			
Instrument lower panel LH	[10]			
Driver air bag module	[11]			
Steering wheel	[12]			
Steering column covers	[13]	[1]		
Combination switch	[14]	[2]		
Spiral cable	[15]			
Cluster lid A (upper)	[16]	[3]		
Cluster lid A	[17]	[4]		
Combination meter	[18]	[5]		
Instrument harness fixing clips	[19]			
Trip A/B reset switch harness connector	[20]			
Front body side welt LH	[21]			
Front pillar garnish LH	[22]			
Antenna connectors	[23]			
Harness clip	[24]			
Speaker grille LH	[25]			
Center speaker grille	[26]			
Center speaker (with BOSE AUDIO)	[27]			
Instrument side panel LH	[28]			
Inside key antenna	[29]			
Harness connector bracket fixing screw	[30]			
Cluster lid C	[31]		[2]	

INSTRUMENT PANEL ASSEMBLY

< REMOVAL AND INSTALLATION >

Cluster lid D	[32]		[3]	
Display unit	[33]		[4]	
AV control unit	[34]		[5]	
Push button ignition switch	[35]			
Front defroster grille LH	[36]			
Front defroster grille RH	[37]			
Instrument side finisher RH	[38]			
Glove box assembly	[39]			
Instrument lower cover	[40]			
Instrument lower panel RH	[41]			
Passenger air bag module connector	[42]			
Passenger air bag module fixing bolt	[43]			
Instrument side panel RH	[44]			
Front body side welt RH	[45]			
Front pillar garnish RH	[46]			
Speaker grille RH	[47]			
Instrument panel assembly	[48]			

[]: Number indicates step in removal procedures.

WARNING:



Before servicing, turn ignition switch OFF, disconnect battery negative terminal and wait 3 minutes or more.

CAUTION:

When removing, always use a remover tool that is made of plastic.

REMOVAL

1. Remove console finisher assembly.
 1. Put selector lever in drive position.
 2. Remove selector lever knob. Refer to [TM-179, "Removal and Installation"](#).
 3. Pull console finisher (1), upward to disengage from center console.
 4. Disconnect harness connectors.

-  : Pawl
 : Metal clip

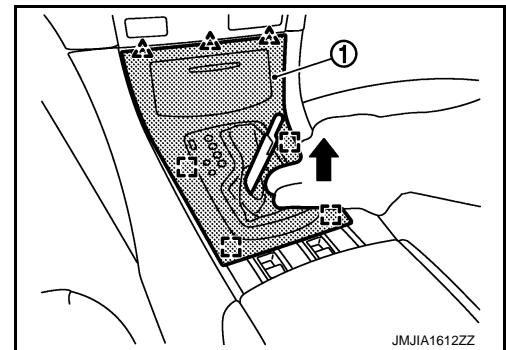

2. Disconnect console sub harness connectors (A).
3. Remove center console assembly fixing screws (B).

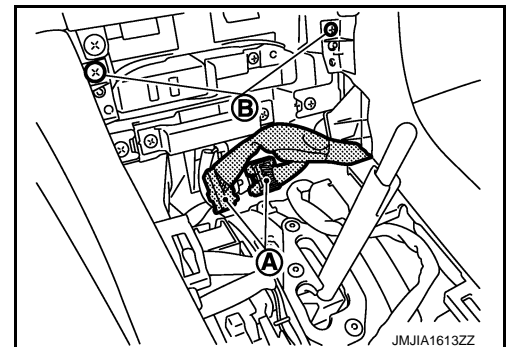

INSTRUMENT PANEL ASSEMBLY

< REMOVAL AND INSTALLATION >

4. Remove console center finisher.
 1. Open the console lid assembly.
 2. Remove console pocket.
 3. Pull upward to release console center finisher fixing pawls from center console assembly.
 4. Disconnect harness connectors.

 : Pawl

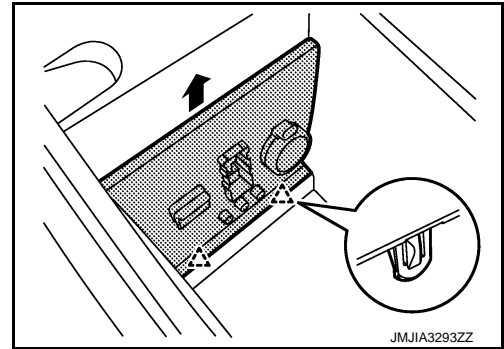

5. Remove console rear finisher.
 1. Put front seat to frontmost position.
 2. Pull back the console rear finisher (1) with remover tool (A).
 3. Disconnect inside key antenna connector.

 : Metal clip

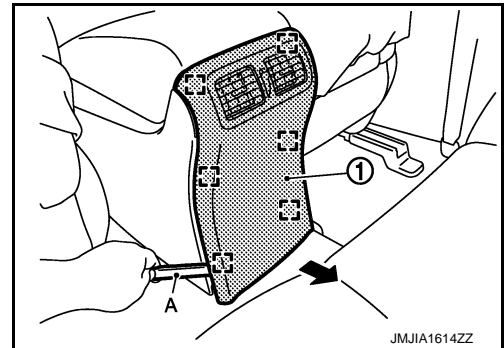

6. Remove rear ventilator duct 2 (1). Refer to [VTL-16. "REAR VENTILATOR DUCT 2 : Removal and Installation"](#).
7. Remove center console assembly fixing screws (A).

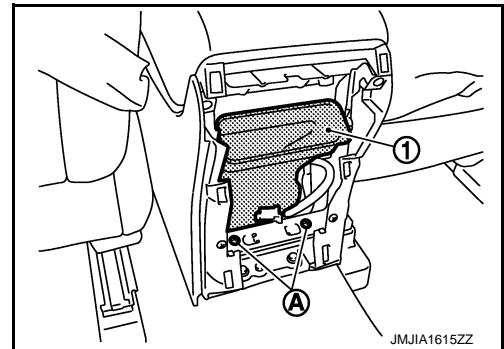

8. Remove center console assembly.
 1. Put front seat to rearmost position.
 2. Lift up center console assembly back side.
9. Remove instrument side finisher LH.
 1. Insert a remover tool into lower space.
 2. Pull the instrument side finisher LH (1) crosswise.

 : Clip

 : Pawl

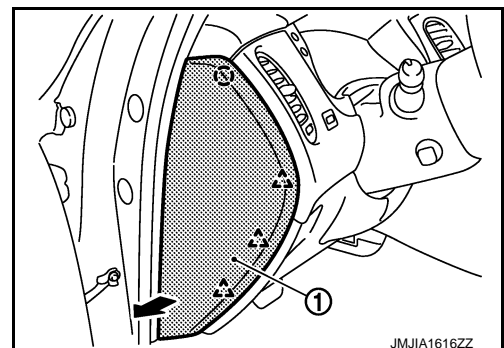

A
B
C
D
E
F
G
H
I
IP
K
L
M
N
O
P

INSTRUMENT PANEL ASSEMBLY

< REMOVAL AND INSTALLATION >

10. Remove instrument lower panel LH.

1. Remove hood opener lever fixing bolts (A).
2. Pull back instrument lower panel LH (1).
3. Remove skirt clips of steering column lower cover (2).
4. Release data link connector (pawl) then remove it from instrument lower panel LH.
5. Disconnect harness connectors and aspirator duct.

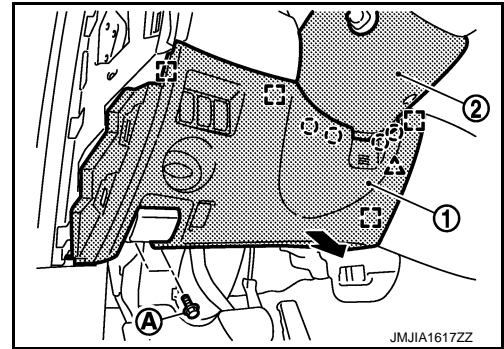
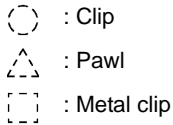

11. Remove driver air bag module. Refer to [SR-11. "Removal and Installation"](#).

12. Remove steering wheel. Refer to [ST-15. "Removal and Installation"](#).

13. Remove steering column covers.

1. Remove steering column mask (1).
2. Remove steering column cover fixing screws (A).
3. Pull up steering column upper cover (2).
4. Remove cluster lid A (4) fixing clips and pawls, and then remove steering column upper cover.
5. Pull down steering column lower cover (3), and then remove steering column lower cover.
6. Disconnect ADP steering switch connector. (with ADP)

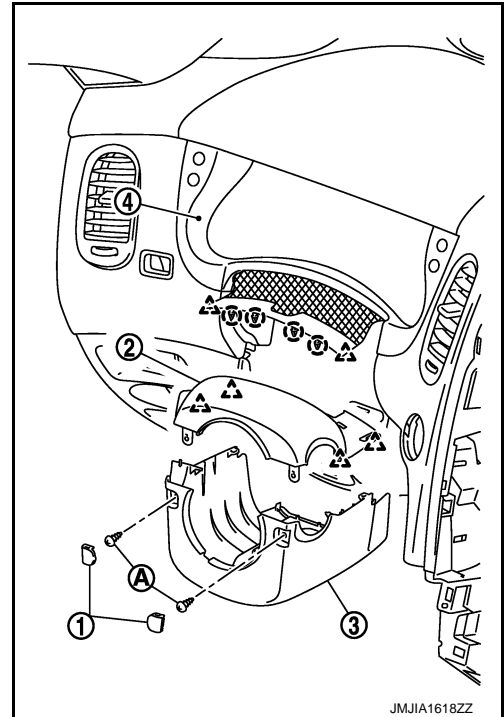
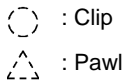

14. Remove combination switch. Refer to [BCS-93. "Removal and Installation"](#).

15. Remove spiral cable. Refer to [SR-14. "Removal and Installation"](#).

16. Remove cluster lid A (upper).

1. Pull back cluster lid A (upper) (1), and disengage pawls and metal clips.
2. Remove cluster lid A (upper).

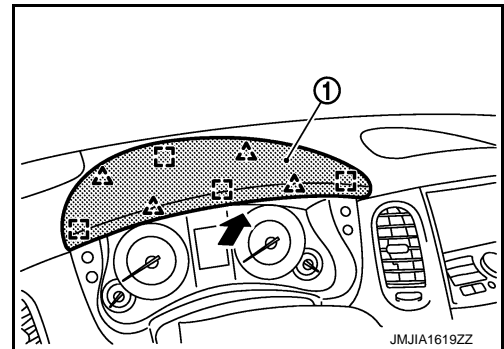
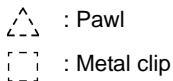

INSTRUMENT PANEL ASSEMBLY

< REMOVAL AND INSTALLATION >

17. Remove cluster lid A.
 1. Remove cluster lid A (1) fixing screws (A).
 2. Pull back cluster lid A, and disengage metal clips.
 3. Remove cluster lid A.

 : Metal clip

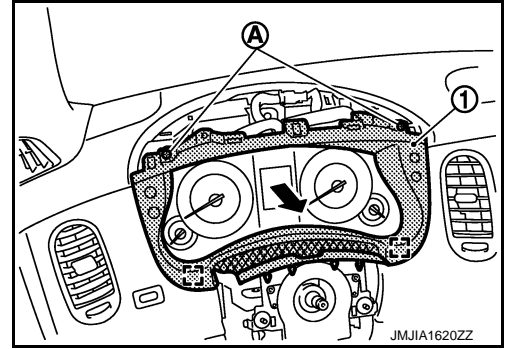

18. Remove combination meter. Refer to [MWI-134, "Exploded View"](#).
19. Remove instrument harness (1) fixing clips (A).

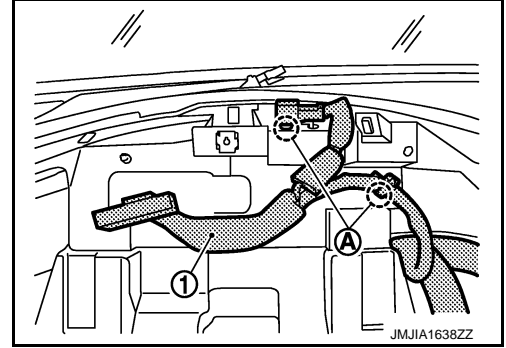

20. Disconnect trip A/B reset switch (1) harness connector (A). Refer to [MWI-137, "Exploded View"](#).

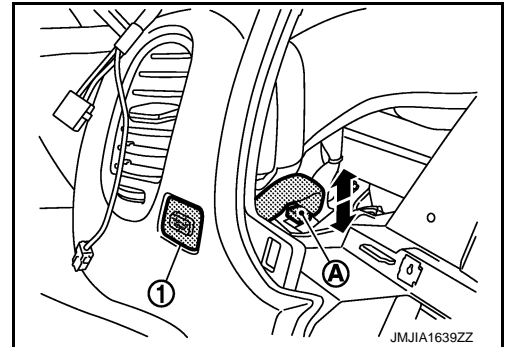

21. Remove front body side welt LH. Refer to [INT-20, "Removal and Installation"](#).
22. Remove front pillar garnish LH. Refer to [INT-20, "Removal and Installation"](#).
23. Disconnect antenna connectors (A).
24. Remove harness clip (B).

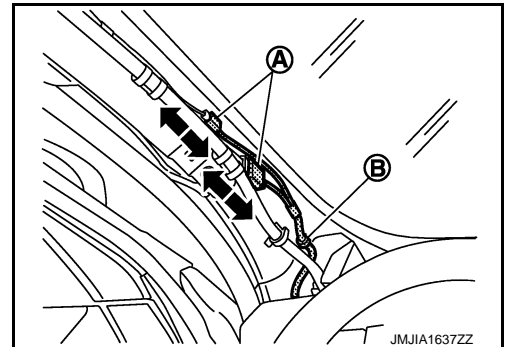

A
B
C
D
E
F
G
H
I
IP
K
L
M
N
O
P

INSTRUMENT PANEL ASSEMBLY

< REMOVAL AND INSTALLATION >

25. Remove speaker grille LH.

1. Pull up and back speaker grille LH (1).
2. Disconnect front squawker harness connector.

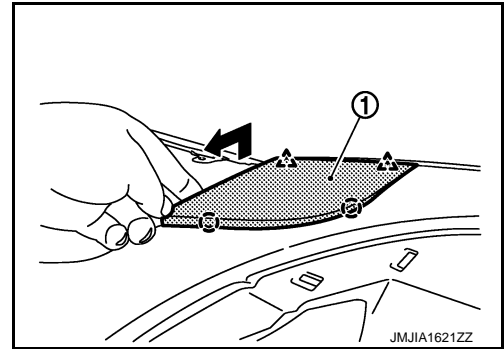
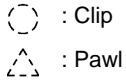

26. Remove center speaker grille.

1. Disengage center speaker grille (1) fixing clips and pawls with remover tool (A).
2. Pull up center speaker grille.

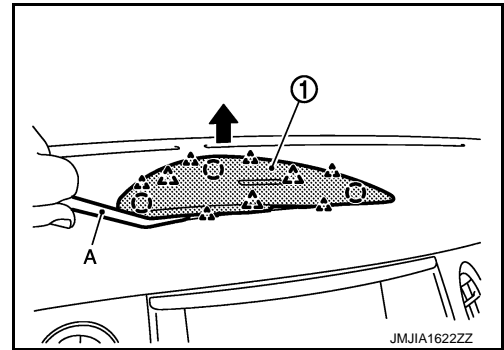
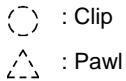

27. Remove center speaker (with BOSE AUDIO). Refer to [AV-322, "Removal and Installation"](#).

28. Remove instrument side panel LH.

1. Remove instrument side panel LH (1) fixing screws (A).
2. Pull toward the arrow direction.

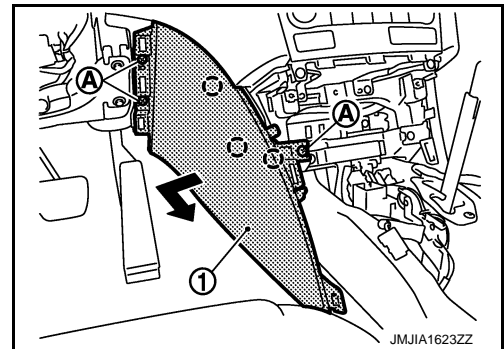
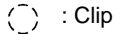

29. Remove inside key antenna. Refer to [DLK-275, "INSTRUMENT CENTER : Removal and Installation"](#).

30. Remove harness connector bracket (1) fixing screw (A).

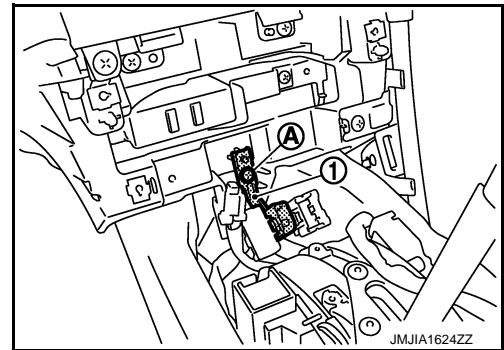

INSTRUMENT PANEL ASSEMBLY

< REMOVAL AND INSTALLATION >

31. Remove cluster lid C.

1. Remove cluster lid C (1) fixing screws (A).
2. Pull down and back cluster lid C.
3. Disconnect harness connectors.

 : Pawl

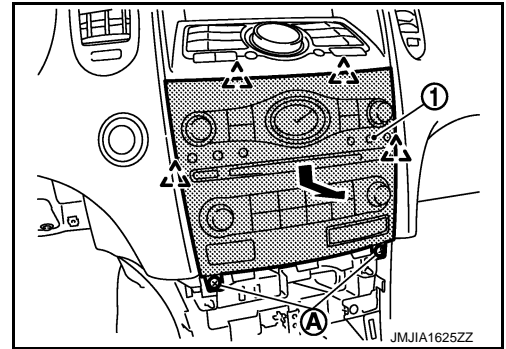

32. Remove cluster lid D.

1. Remove cluster lid D (1) fixing screws (A).
2. Pull back cluster lid D.
3. Disconnect harness connectors.

 : Pawl

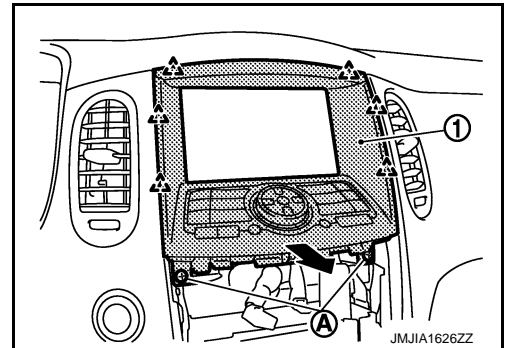

33. Remove display unit. Refer to [AV-129, "Removal and Installation"](#).

34. Remove AV control unit. Refer to [AV-128, "Removal and Installation"](#).

35. Remove push button ignition switch. Refer to [SEC-192, "Removal and Installation"](#).

36. Remove front defroster grille LH. Refer to [VTL-13, "FRONT DEFROSTER GRILLE : Removal and Installation"](#).

37. Remove front defroster grille RH. Refer to [VTL-13, "FRONT DEFROSTER GRILLE : Removal and Installation"](#).

38. Remove instrument side finisher RH.

1. Insert a remover tool into lower space.
2. Pull the instrument side finisher RH (1) crosswise.

 : Clip

 : Pawl

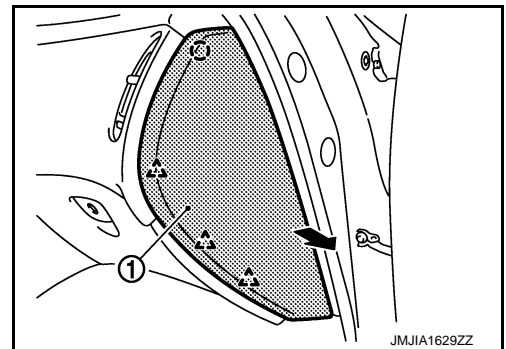

39. Remove glove box assembly.

1. Open the glove box.
2. Pull back glove box assembly (1).

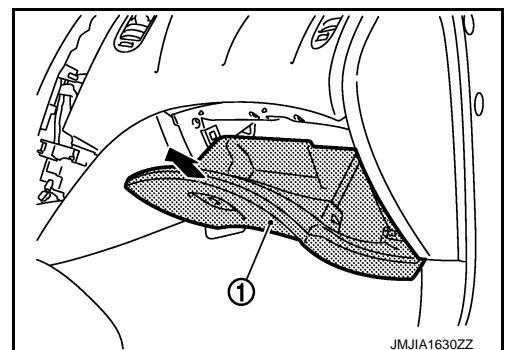

A
B
C
D
E
F
G
H
I
IP
K
L
M
N
O
P

INSTRUMENT PANEL ASSEMBLY

< REMOVAL AND INSTALLATION >

3. Remove damper pin (1) of left side.

 : Clip

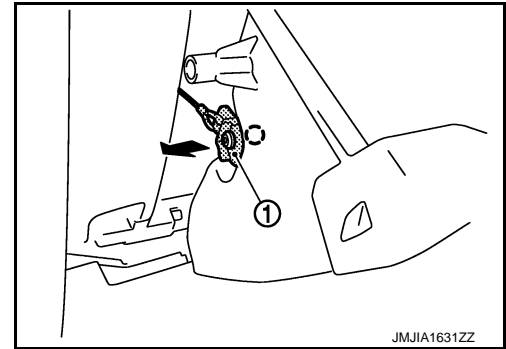

40. Remove instrument lower cover.

1. Pull downward, disengaged pawls.
2. Pull back instrument lower cover (1).
3. Disconnect illumination lamp harness connector.

 : Pawl

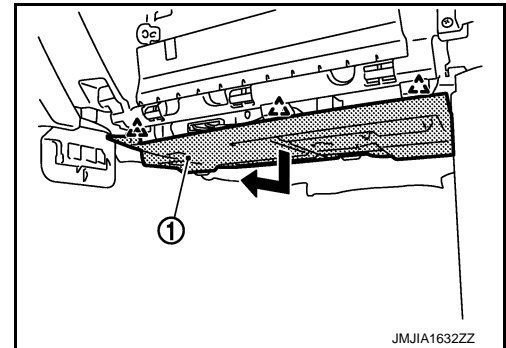

41. Remove instrument lower panel RH.

1. Remove instrument lower panel RH (1) fixing screws (A).
2. Pull back instrument lower panel RH.
3. Disconnect glove box lamp harness connector.

 : Pawl

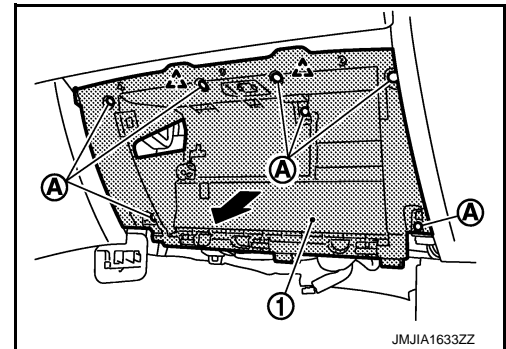

42. Disconnect passenger air bag module connector. Refer to [SR-17, "Exploded View"](#).

43. Remove passenger air bag module fixing bolt. Refer to [SR-17, "Removal and Installation"](#).

44. Remove instrument side panel RH.

1. Remove instrument side panel RH (1) fixing screws (A).
2. Pull toward the arrow direction.

 : Clip

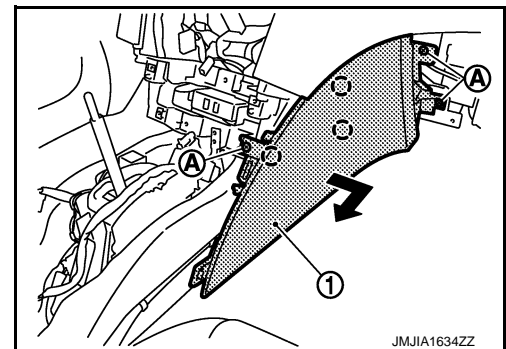

45. Remove front body side welt RH. Refer to [INT-20, "Removal and Installation"](#).

46. Remove front pillar garnish RH. Refer to [INT-20, "Removal and Installation"](#).

INSTRUMENT PANEL ASSEMBLY

< REMOVAL AND INSTALLATION >

47. Remove speaker grille RH.

1. Pull up and back tweeter grille RH (1).
2. Disconnect front squawker harness connector.

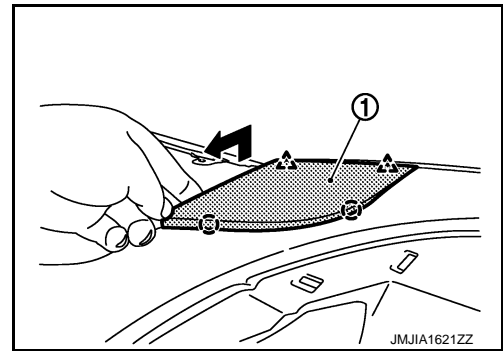
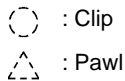

48. Remove instrument panel assembly.

1. Remove instrument panel assembly mounting bolts (A), screws (B) and clips (C).

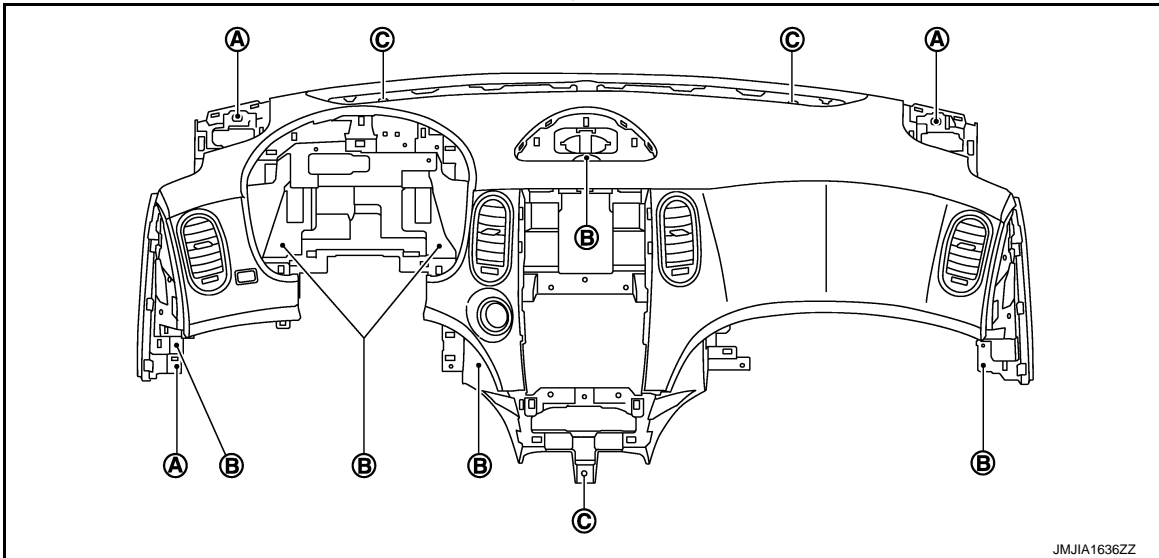

CAUTION:

Cover tool with a shop cloth to prevent windshield glass being damaged.

2. Remove instrument panel from passenger door opening portion.

CAUTION:

- Cover center console upper surface with a shop cloth to prevent it from being damaged.
- When removing instrument panel assembly, 2 workers are required so as to prevent it from dropping.

49. Remove the following parts after removing instrument panel assembly.

- Passenger air bag module: Refer to [SR-17, "Removal and Installation"](#).
- Center ventilator grille LH/RH: Refer to [VTL-12, "CENTER VENTILATOR GRILLE : Removal and Installation"](#).
- Side ventilator grille LH/RH: Refer to [VTL-12, "SIDE VENTILATOR GRILLE : Removal and Installation"](#).
- Ventilator duct LH/RH: Refer to [VTL-13, "VENTILATOR DUCT : Removal and Installation"](#).
- Adaptor duct: Refer to [VTL-14, "ADAPTOR DUCT : Removal and Installation"](#).
- Defroster nozzle: Refer to [VTL-14, "DEFROSTER NOZZLE : Removal and Installation"](#).
- Side defroster nozzle LH/RH: Refer to [VTL-14, "SIDE DEFROSTER NOZZLE : Removal and Installation"](#).
- Antenna feeder: Refer to [AV-144, "Feeder Layout"](#).
- GPS antenna: Refer to [AV-534, "Exploded View"](#).
- Trip A/B reset switch: Refer to [MWI-137, "Removal and Installation"](#).

INSTALLATION

Note the following items, and then install in the reverse order of removal.

CAUTION:

- Never use the steering wheel mounting nut after removal, replace with the new nut.
- Never use the driver air bag module mounting bolts after removal, replace with the new bolts.
- Never use the passenger air bag module mounting bolt after removal, replace with the new bolt.

CENTER CONSOLE ASSEMBLY

< REMOVAL AND INSTALLATION >

CENTER CONSOLE ASSEMBLY

Exploded View

INFOID:000000007459374

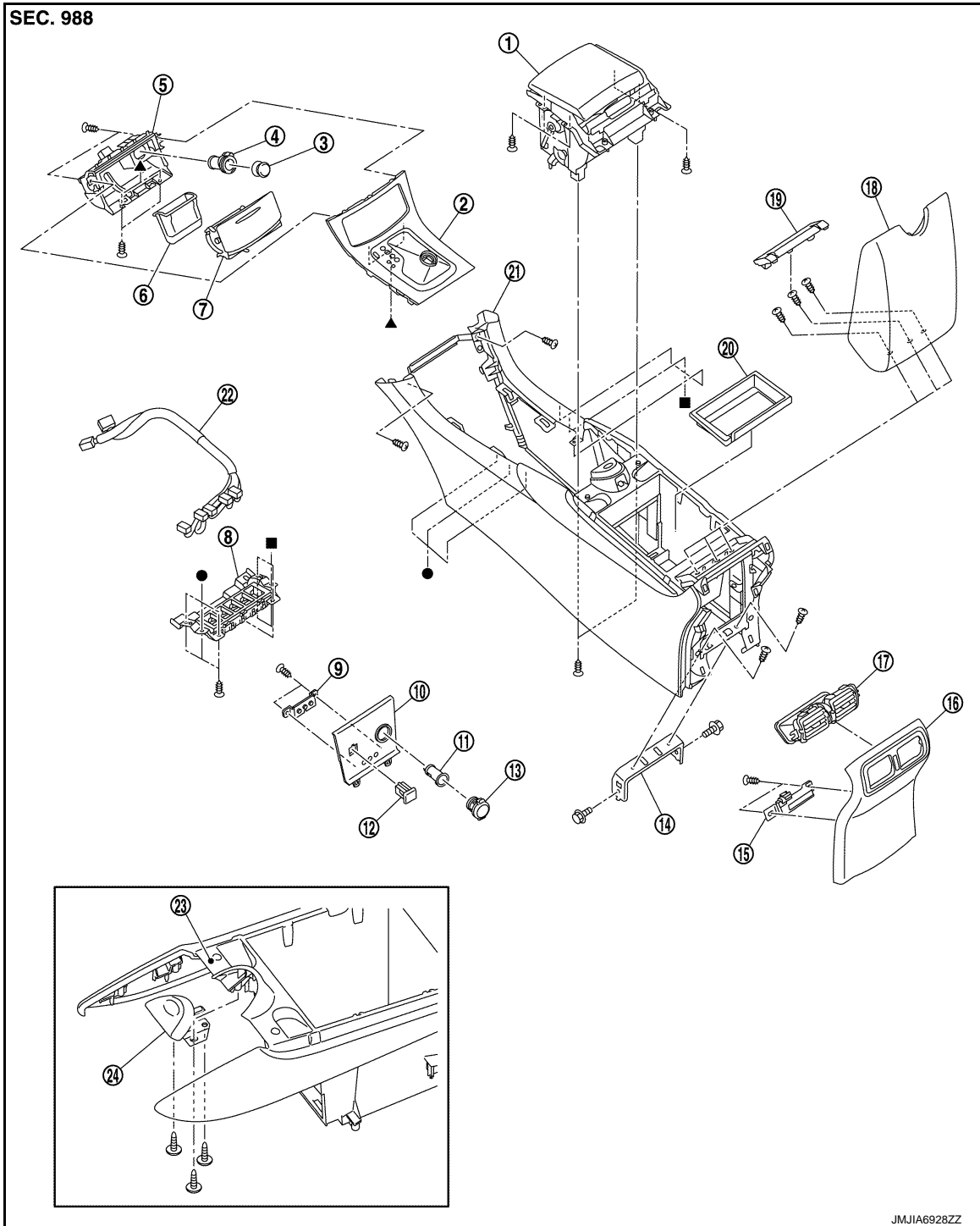

- | | | |
|-----------------------------|------------------------------|--------------------------|
| 1. Cup holder assembly | 2. Console finisher assembly | 3. Socket knob |
| 4. Socket inner case | 5. Pocket | 6. Inner ashtray |
| 7. Ashtray lid | 8. Switch panel | 9. Mask |
| 10. Console center finisher | 11. Socket inner case | 12. USB connector |
| 13. Socket knob | 14. Console bracket | 15. Inside key antenna |
| 16. Console rear finisher | 17. Rear ventilator grille | 18. Console lid assembly |

CENTER CONSOLE ASSEMBLY

< REMOVAL AND INSTALLATION >

- | | | |
|-------------------------|--------------------|--------------------------------|
| 19. Console mask | 20. Console pocket | 21. Center console assembly |
| 22. Console sub harness | 23. Console box | 24. Console lid release button |

Removal and Installation



INFOID:000000007459375

CAUTION:

When removing, always use a remover tool that is made of plastic.

REMOVAL

- Remove console finisher assembly.
 - Put selector lever in drive position.
 - Remove selector lever knob. Refer to [TM-179, "Removal and Installation"](#).
 - Pull console finisher (1), upward to disengage from center console.
 - Disconnect harness connectors.

-  : Pawl
-  : Metal clip

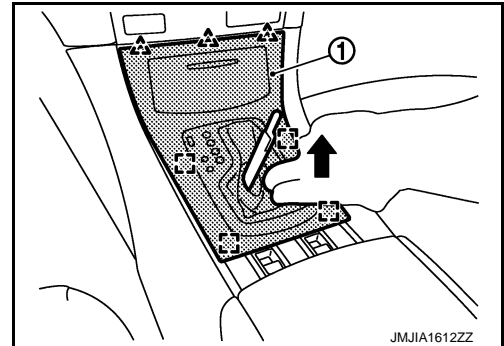

- Disconnect console sub harness connectors (A).
- Remove center console assembly fixing screws (B).

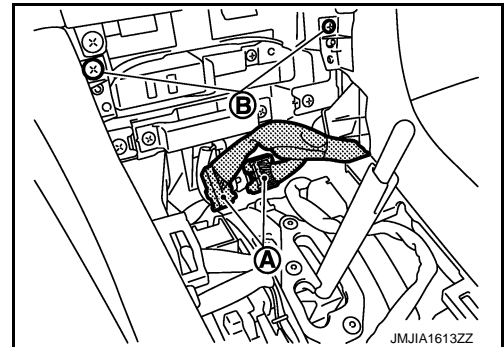

- Remove console center finisher.
 - Open the console lid assembly.
 - Remove console pocket.
 - Pull upward to release console center finisher fixing pawls from center console assembly.
 - Disconnect harness connectors.

-  : Pawl

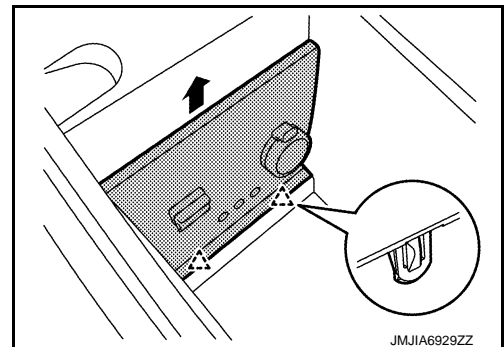

- Remove console rear finisher.
 - Put front seat to frontmost position.
 - Pull back the console rear finisher (1) with remover tool (A).
 - Disconnect inside key antenna connector.

-  : Metal clip

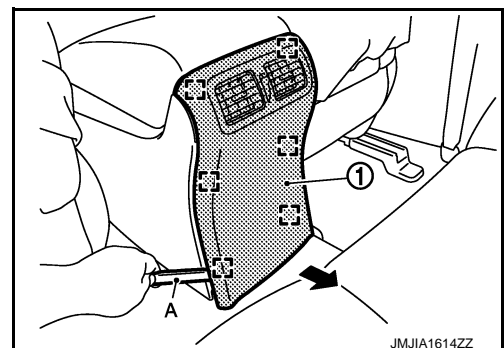

A
B
C
D
E
F
G
H
I
IP
K
L
M
N
O
P

CENTER CONSOLE ASSEMBLY

< REMOVAL AND INSTALLATION >

6. Remove rear ventilator duct 2 (1). Refer to [VTL-16. "REAR VENTILATOR DUCT 2 : Removal and Installation"](#).
7. Remove center console assembly fixing screws (A).

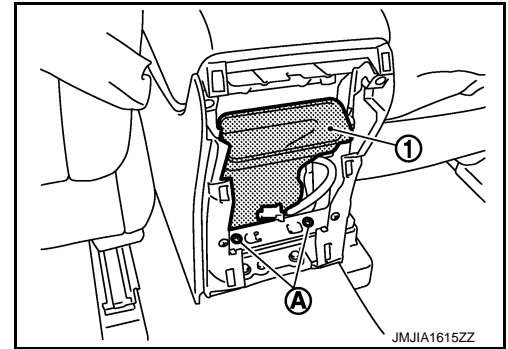

8. Remove center console assembly.
 1. Put front seat to rearmost position.
 2. Lift up center console assembly back side.
 3. Disconnect harness connectors.

INSTALLATION

Install in the reverse order of removal.

Disassembly and Assembly

INFOID:000000007459376

CAUTION:

When disassembling, always use a remover tool that is made of plastic.

DISASSEMBLY

1. Remove console lid assembly.
 1. Open the console lid.
 2. From the back of the center console, push the pawls forward to remove the console mask (1).

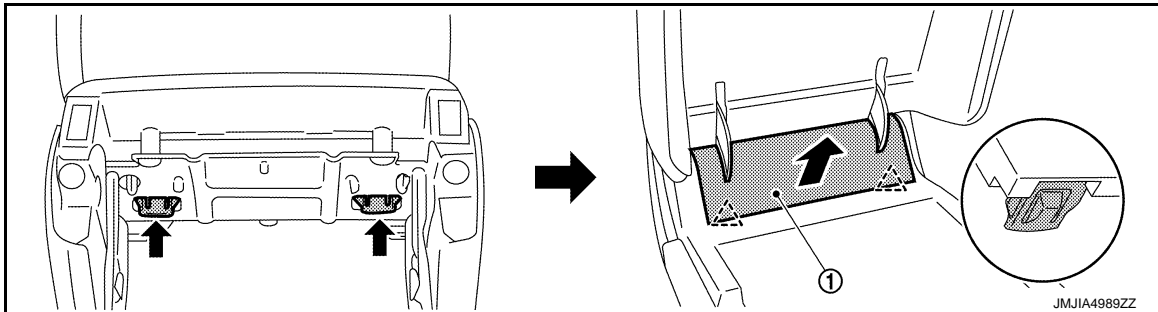

 : Pawl

3. Remove console lid assembly (1) fixing screws (A), and then remove console lid assembly.

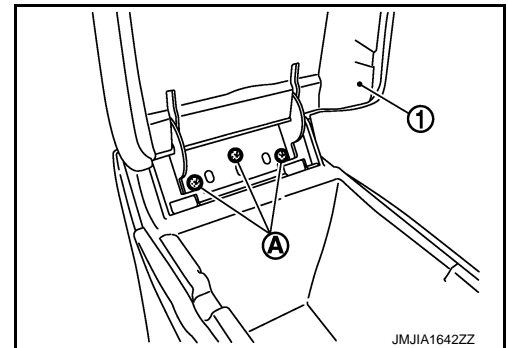

2. Remove console pocket.
3. Reverse a center console assembly.

CENTER CONSOLE ASSEMBLY

< REMOVAL AND INSTALLATION >

4. Remove console sub harness.
1. Remove console sub harness (1) fixing screws (A).
 2. Remove console sub harness fixing clip (B).
 3. Disconnect switch connectors.

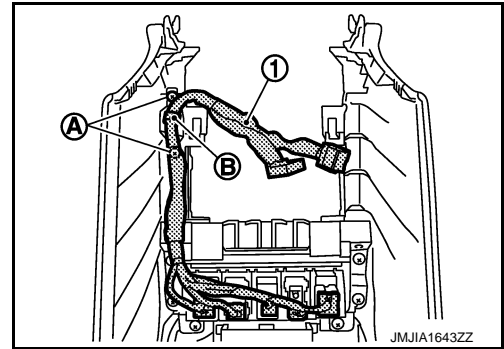

5. Remove switch panel.
1. Remove switch panel (1) fixing screws (A).
 2. Pull up switch panel.

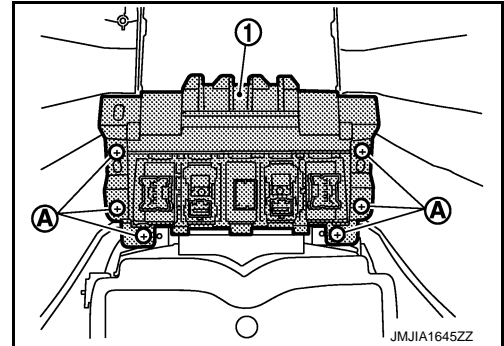

6. Remove console center bracket.
1. Remove console center bracket (1) fixing screws (A).
 2. Pull up console center bracket.

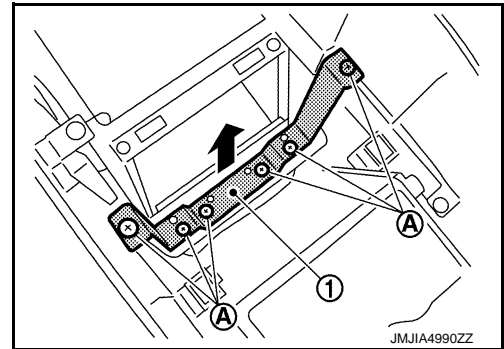

7. Remove console pad LH.
1. Remove console pad LH (1) fixing screws (A).
 2. Pull the console pad LH crosswise.

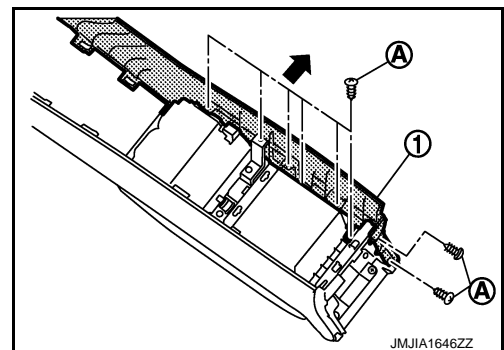

8. Remove console pad RH.
1. Remove console pad RH (1) fixing screws (A).
 2. Pull the console pad RH crosswise.

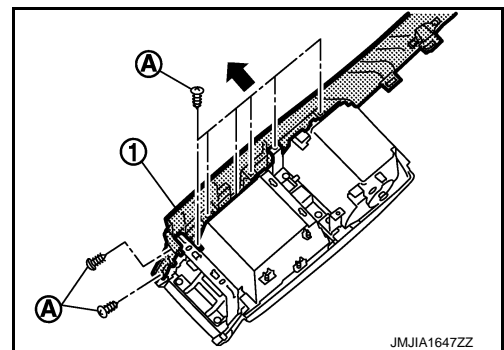

A
B
C
D
E
F
G
H
I
IP
K
L
M
N
O
P

CENTER CONSOLE ASSEMBLY

< REMOVAL AND INSTALLATION >

9. Remove cup holder assembly.
1. Remove cup holder assembly (1) fixing screws (A).
 2. Pull up cup holder assembly.

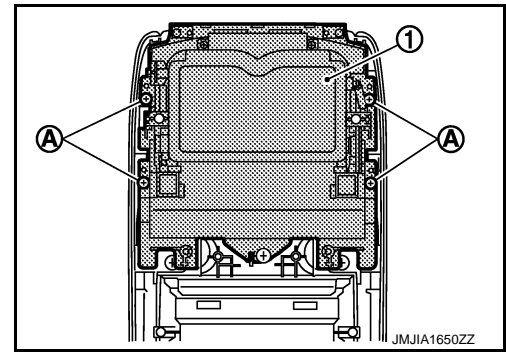

10. Remove console lid release button.
1. Remove console lid release button (1) fixing screws (A).
 2. Pull toward the arrow direction.

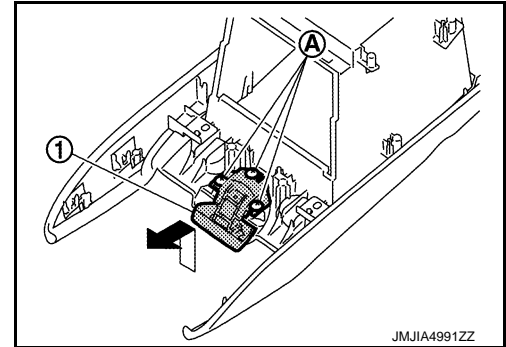

11. Remove console upper bracket.
1. Remove console upper bracket (1) fixing screws (A).
 2. Pull up console upper bracket.

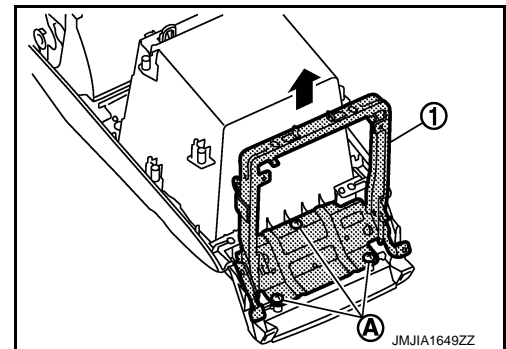

NOTE:

- For remove and installation procedures of console power socket. Refer to [PWO-5, "CONSOLE POWER SOCKET : Removal and Installation"](#).
- For remove and installation procedures of USB connector. Refer to [AV-531, "Removal and Installation"](#).

ASSEMBLY

Assemble in the reverse order of disassembly.