

ENGINE LUBRICATION SYSTEM

CONTENTS

PRECAUTION	2	Inspection	11	F
PRECAUTIONS	2	REMOVAL AND INSTALLATION	12	
Precautions For Engine Service	2	OIL FILTER BRACKET (AWD)	12	G
Liquid Gasket	2	Exploded View	12	
PREPARATION	4	Removal and Installation	12	
PREPARATION	4	Inspection	13	H
Special Service Tools	4	UNIT DISASSEMBLY AND ASSEMBLY ...	14	
Commercial Service Tools	4	OIL PUMP	14	I
SYSTEM DESCRIPTION	6	Exploded View	14	
DESCRIPTION	6	Disassembly and Assembly	14	J
Engine Lubrication System	6	Inspection	15	
Engine Lubrication System Schematic	6	SERVICE DATA AND SPECIFICATIONS		
PERIODIC MAINTENANCE	7	(SDS)	17	K
ENGINE OIL	7	SERVICE DATA AND SPECIFICATIONS		
Inspection	7	(SDS)	17	L
Draining	9	Periodical Maintenance Specification	17	
Refilling	9	Engine Oil Pressure	17	
OIL FILTER	10	Oil Pump	17	M
Removal and Installation	10	Regulator Valve	17	

PRECAUTIONS

< PRECAUTION >

PRECAUTION

PRECAUTIONS

Precautions For Engine Service

INFOID:000000009355920

DISCONNECTING FUEL PIPING

- Before starting work, check no fire or spark producing items are in the work area.
- Release fuel pressure before disconnecting and disassembly.
- After disconnecting pipes, plug openings to stop fuel leakage.

DRAINING ENGINE COOLANT

Drain engine coolant and engine oil when the engine is cooled.

INSPECTION, REPAIR AND REPLACEMENT

Before repairing or replacing, thoroughly inspect parts. Inspect new replacement parts in the same way, and replace if necessary.

REMOVAL AND DISASSEMBLY

- When instructed to use SST, use specified tools. Always be careful to work safely, avoid forceful or uninstructed operations.
- Exercise maximum care to avoid damage to mating or sliding surfaces.
- Dowel pins are used for several parts alignment. When replacing and reassembling parts with dowel pins, check that dowel pins are installed in the original position.
- Must cover openings of engine system with a tape or equivalent, to seal out foreign materials.
- Mark and arrange disassembly parts in an organized way for easy troubleshooting and reassembly.
- When loosening nuts and bolts, as a basic rule, start with the one furthest outside, then the one diagonally opposite, and so on. If the order of loosening is specified, do exactly as specified. Power tools may be used in the step.

ASSEMBLY AND INSTALLATION

- Use torque wrench to tighten bolts or nuts to specification.
- When tightening nuts and bolts, as a basic rule, equally tighten in several different steps starting with the ones in center, then ones on inside and outside diagonally in this order. If the order of tightening is specified, do exactly as specified.
- Replace with new gasket, packing, oil seal or O-ring.
- Thoroughly wash, clean, and air-blow each part. Carefully check engine oil or engine coolant passages for any restriction and blockage.
- Avoid damaging sliding or mating surfaces. Completely remove foreign materials such as cloth lint or dust. Before assembly, oil sliding surfaces well.
- After disassembling, or exposing any internal engine parts, change engine oil and replace oil filter with a new one.
- Release air within route when refilling after draining engine coolant.
- After repairing, start the engine and increase engine speed to check engine coolant, fuel, engine oil, and exhaust gases for leakage.

Liquid Gasket

INFOID:000000007457617

LIQUID GASKET APPLICATION PROCEDURE

1. Remove old liquid gasket adhering to the liquid gasket application surface and the mating surface.
 - Remove liquid gasket completely from the liquid gasket application surface, mounting bolts, and bolt holes.
2. Wipe the liquid gasket application surface and the mating surface with white gasoline (lighting and heating use) to remove adhering moisture, grease and foreign materials.
3. Apply liquid gasket to the liquid gasket application surface.
Use Genuine RTV Silicone Sealant or equivalent. Refer to [GI-22, "Recommended Chemical Products and Sealants"](#).

PRECAUTIONS

< PRECAUTION >

- Within five minutes of liquid gasket application, install the mating component.
- If liquid gasket protrudes, wipe it off immediately.
- Do not retighten mounting bolts or nuts after the installation.
- After 30 minutes or more have passed from the installation, fill engine oil and engine coolant.

A

LU

C

D

E

F

G

H

I

J

K

L

M

N

O

P

PREPARATION

< PREPARATION >

PREPARATION

PREPARATION

Special Service Tools

INFOID:000000007457618

The actual shapes of Kent-Moore tools may differ from those of special service tools illustrated here.

Tool number (Kent-Moore No.) Tool name	Description
ST25051001 (J-25695-1) Oil pressure gauge	Measuring oil pressure Maximum measuring range: 2,452 kPa (25 kg/cm², 356 psi)
ST25052000 (J-25695-2) Hose	Adapting oil pressure gauge to oil pan (upper)
KV10115801 (J-38956) Oil filter wrench	Removing and installing oil filter a: 64.3 mm (2.531 in)

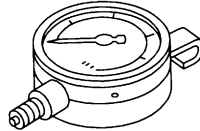

NT050

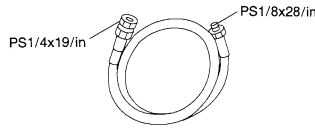

S-NT559

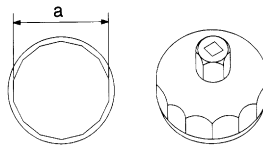

S-NT375

Commercial Service Tools

INFOID:000000007457619

Tool name	Description
Tube presser	Pressing tube of liquid gasket

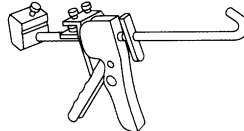

NT052

PREPARATION

< PREPARATION >

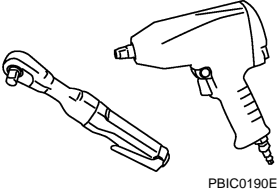
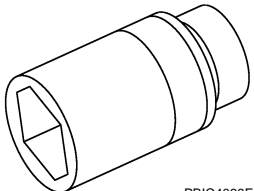
Tool name	Description
<p>Power tools</p>  <p>PBIC0190E</p>	<p>Loosening bolts and nuts</p>
<p>Deep socket</p>  <p>PBIC4066E</p>	<p>Removing and installing oil pressure switch 27 mm (1.06 in)</p>

A

LU

C

D

E

F

G

H

I

J

K

L

M

N

O

P

DESCRIPTION

< SYSTEM DESCRIPTION >

SYSTEM DESCRIPTION

DESCRIPTION

Engine Lubrication System

INFOID:000000007457615

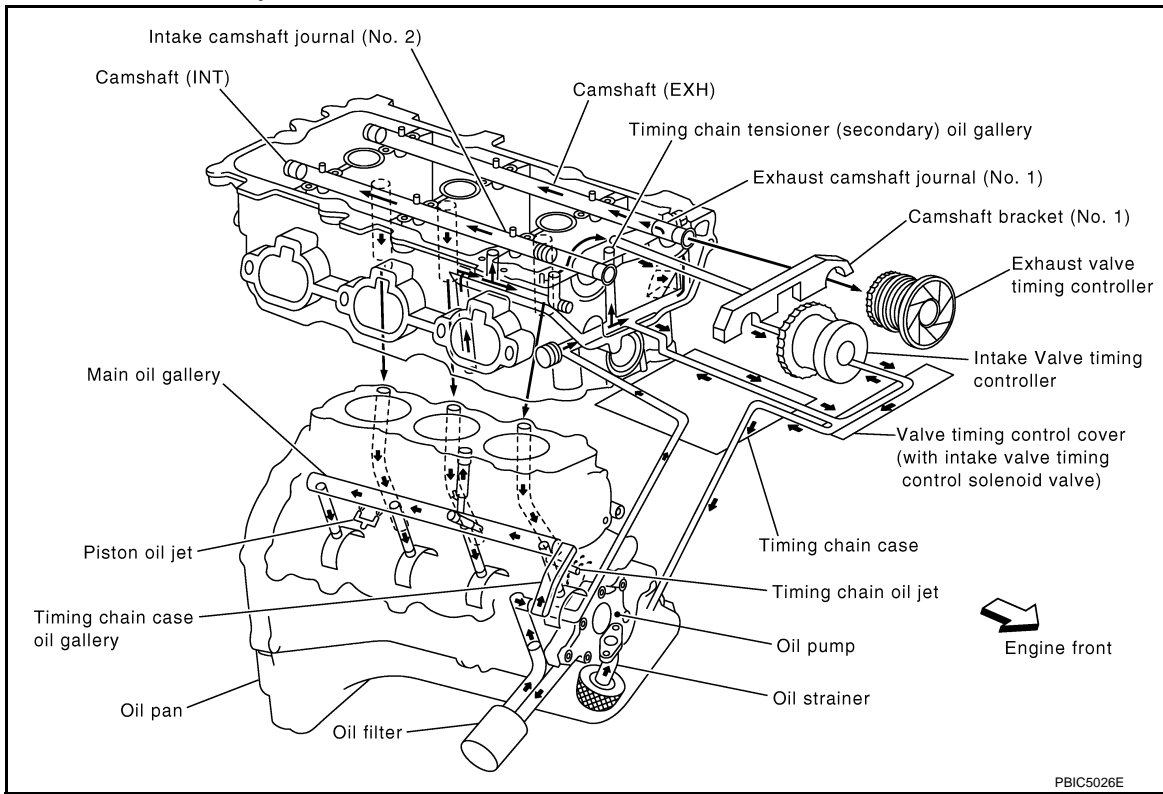

Engine Lubrication System Schematic

INFOID:000000007457616

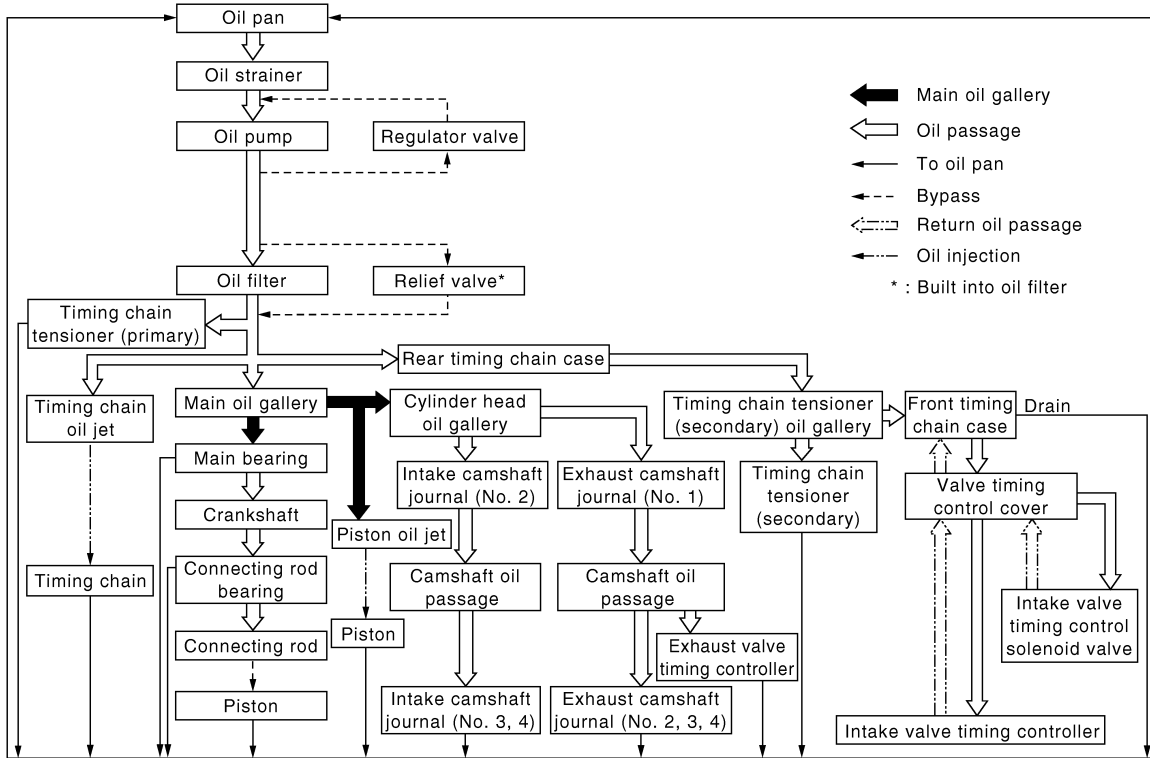

PERIODIC MAINTENANCE

ENGINE OIL

Inspection

INFOID:000000007457620

A

LU

ENGINE OIL LEVEL

NOTE:

Before starting engine, put vehicle horizontally and check the engine oil level. If engine is already started, stop it and allow 10 minutes before checking.

1. Pull out oil level gauge and wipe it clean.
2. Insert oil level gauge and check the engine oil level is within the range (A) shown in the figure.
3. If it is out of range, adjust it.

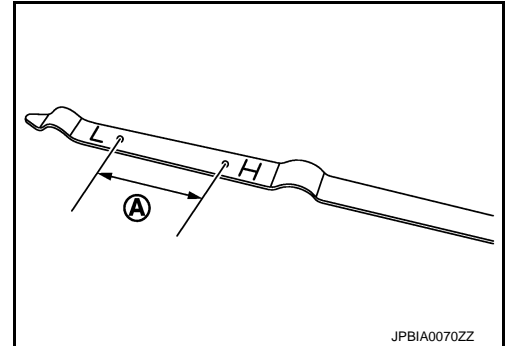

C

D

E

F

G

NOTE:

When checking the engine oil level, insert oil level gauge (1) with its tip aligned with oil level gauge guide.

2 : Engine cover

⇐ : Engine front

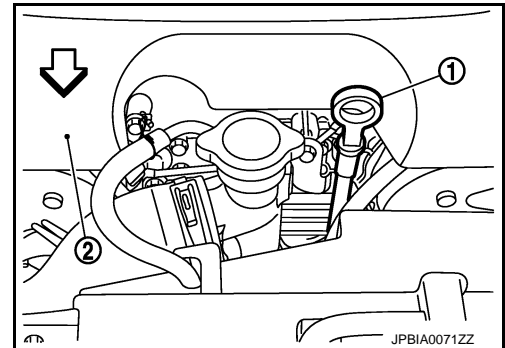

H

I

J

K

ENGINE OIL APPEARANCE

- Check engine oil for white turbidity or heavy contamination.
- If engine oil becomes turbid and white, it is highly probable that it is contaminated with engine coolant. Repair or replace damaged parts.

ENGINE OIL LEAKAGE

Check for engine oil leakage around the following areas:

- Oil pans (lower and upper)
- Oil pan drain plug
- Oil pressure switch
- Oil temperature sensor
- Oil filter
- Oil filter bracket (AWD models)
- Valve timing control cover
- Mating surface between cylinder head and rocker cover
- Mating surface between front timing chain case and rear timing chain case
- Mating surface between rear timing chain case and cylinder head
- Mating surface between rear timing chain case and cylinder block
- Mating surface between rear timing chain case and oil pan (upper)
- Mating surface between cylinder block and cylinder head
- Mating surface between lower cylinder block and cylinder block
- Crankshaft oil seals (front and rear)
- Camshaft position sensor (PHASE) and exhaust valve timing control position sensor

L

M

N

O

P

ENGINE OIL

< PERIODIC MAINTENANCE >

OIL PRESSURE CHECK

WARNING:

- **Never get burn yourself, as engine oil may be hot.**
- **Oil pressure check should be done in "Parking position".**

1. Check the engine oil level.
2. Remove engine undercover, using a power tool.
3. Disconnect harness connector at oil pressure switch, and remove oil pressure switch using deep socket (commercial service tool).

CAUTION:

Never drop or shock oil pressure switch.

- 2WD models (A)

1 : Oil pressure switch

⇐ : Engine front

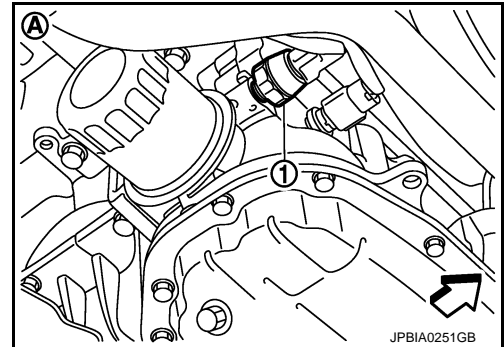

- AWD models (A)

1 : Oil pressure switch

2 : Front final drive

⇐ : Engine front

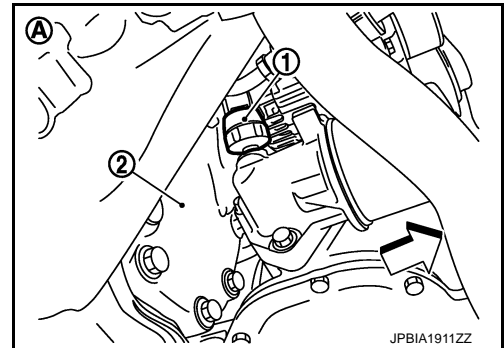

4. Install the oil pressure gauge [SST: ST25051001 (J-25695-1)] (A) and hose [SST: ST25052000 (J-25695-2)] (B).

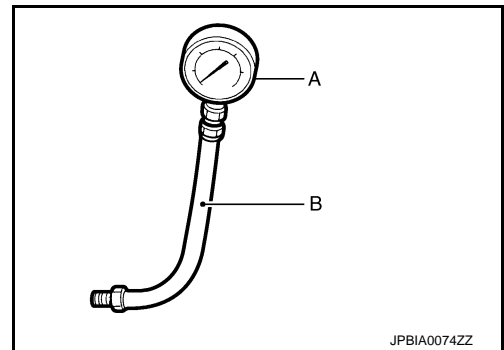

5. Start the engine and warm it up to normal operating temperature.
6. Check the engine oil pressure with engine running under no-load.

NOTE:

When the engine oil temperature is low, the engine oil pressure becomes high.

Engine oil pressure : Refer to [LU-17, "Engine Oil Pressure"](#).

If difference is extreme, check engine oil passage and oil pump for engine oil leakage.

7. After the inspections, install oil pressure switch as follows:
 - a. Remove old liquid gasket adhering to oil pressure switch and the mating surface.
 - b. Apply liquid gasket and tighten oil pressure switch to the specification.

ENGINE OIL

< PERIODIC MAINTENANCE >

Use Genuine RTV Silicone Sealant or equivalent. Refer to [GI-22, "Recommended Chemical Products and Sealants"](#).

2WD models

Tightening torque : Refer to [EM-43, "Exploded View \(2WD\)"](#).

AWD models

Tightening torque : Refer to [LU-12, "Exploded View"](#).

c. After warming up engine, check there is no leakage of engine oil with running engine.

Draining

INFOID:000000007457621

WARNING:

- Be careful not to get burn yourself, as engine oil may be hot.
- Prolonged and repeated contact with used engine oil may cause skin cancer. Try to avoid direct skin contact with used engine oil. If skin contact is made, wash thoroughly with soap or hand cleaner as soon as possible.

1. Warm up the engine, and check for engine oil leakage from engine components. Refer to [LU-7, "Inspection"](#).
2. Stop the engine and wait for 10 minutes.
3. Loosen oil filler cap.
4. Remove undercover with power tool.
5. Remove drain plug and then drain engine oil.

Refilling

INFOID:000000007457622

1. Install drain plug with new washer. Refer to [EM-43, "Exploded View \(2WD\)"](#) (2WD models) or [EM-44, "Exploded View \(AWD\)"](#) (AWD models).

CAUTION:

Be sure to clean drain plug and install with new washer.

2WD models

Tightening torque : Refer to [EM-43, "Exploded View \(2WD\)"](#).

AWD models

Tightening torque : Refer to [EM-44, "Exploded View \(AWD\)"](#).

2. Refill with new engine oil.
Engine oil specification and viscosity: Refer to [MA-10, "Fluids and Lubricants"](#).

Engine oil capacity : Refer to [LU-17, "Periodical Maintenance Specification"](#).

CAUTION:

- When filling engine oil, never pull out oil level gauge.
 - The refill capacity depends on the engine oil temperature and drain time. Use these specifications for reference only.
 - Always use oil level gauge to determine the proper amount of engine oil in engine.
3. Warm up the engine and check area around drain plug and oil filter for engine oil leakage.
 4. Stop the engine and wait for 10 minutes.
 5. Check the engine oil level. Refer to [LU-7, "Inspection"](#).

OIL FILTER

< PERIODIC MAINTENANCE >

OIL FILTER

Removal and Installation

INFOID:000000007457623

REMOVAL

CAUTION:

- Oil filter is provided with relief valve. Use genuine NISSAN oil filter or equivalent.
- Never get burned when engine and engine oil may be hot.
- When removing, prepare a shop cloth to absorb any engine oil leakage or spillage.
- Never allow engine oil to adhere to drive belt.
- Completely wipe off any engine oil that adheres to engine and vehicle.

1. Remove engine undercover, using a power tool.
2. Using oil filter wrench [SST: KV10115801 (J-38956)] (B), remove oil filter.

A : 2WD models

⇐ : Engine front

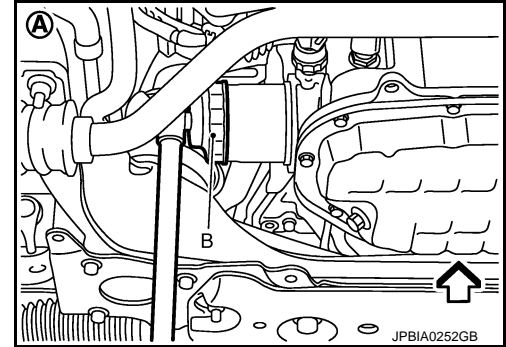

A : AWD models

⇐ : Engine front

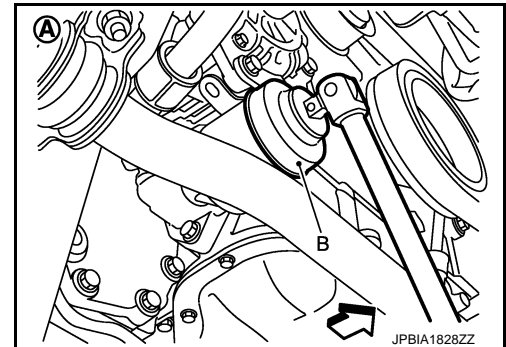

INSTALLATION

1. Remove foreign materials adhering to oil filter installation surface.
2. Apply engine oil to the oil seal contact surface of new oil filter.

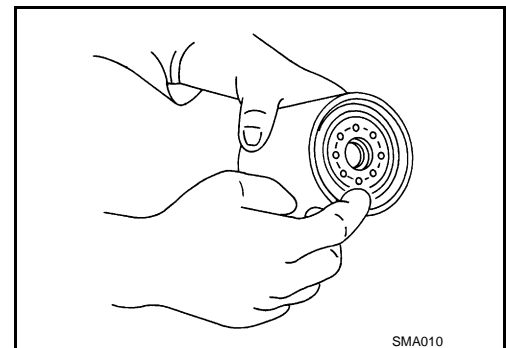

OIL FILTER

< PERIODIC MAINTENANCE >

3. Screw oil filter manually until it touches the installation surface, then tighten it by 2/3 turn (A). Or tighten to the specification.

Oil filter:

: 17.7 N·m (1.8 kg·m, 13 ft·lb)

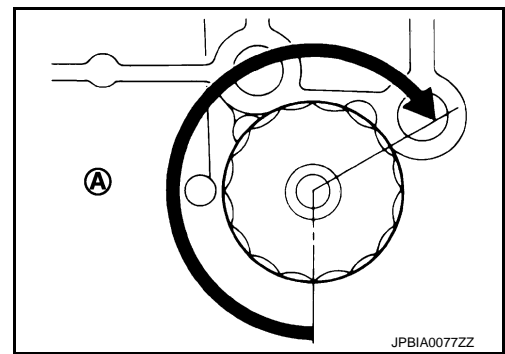

INFOID:000000007457624

Inspection

INSPECTION AFTER INSTALLATION

1. Check the engine oil level. Refer to [LU-7, "Inspection"](#).
2. Start the engine, and check there is no leakage of engine oil.
3. Stop the engine and wait for 10 minutes.
4. Check the engine oil level, and adjust the level. Refer to [LU-7, "Inspection"](#).

A
LU
C
D
E
F
G
H
I
J
K
L
M
N
O
P

OIL FILTER BRACKET (AWD)

< REMOVAL AND INSTALLATION >

REMOVAL AND INSTALLATION

OIL FILTER BRACKET (AWD)

Exploded View

INFOID:000000007457625

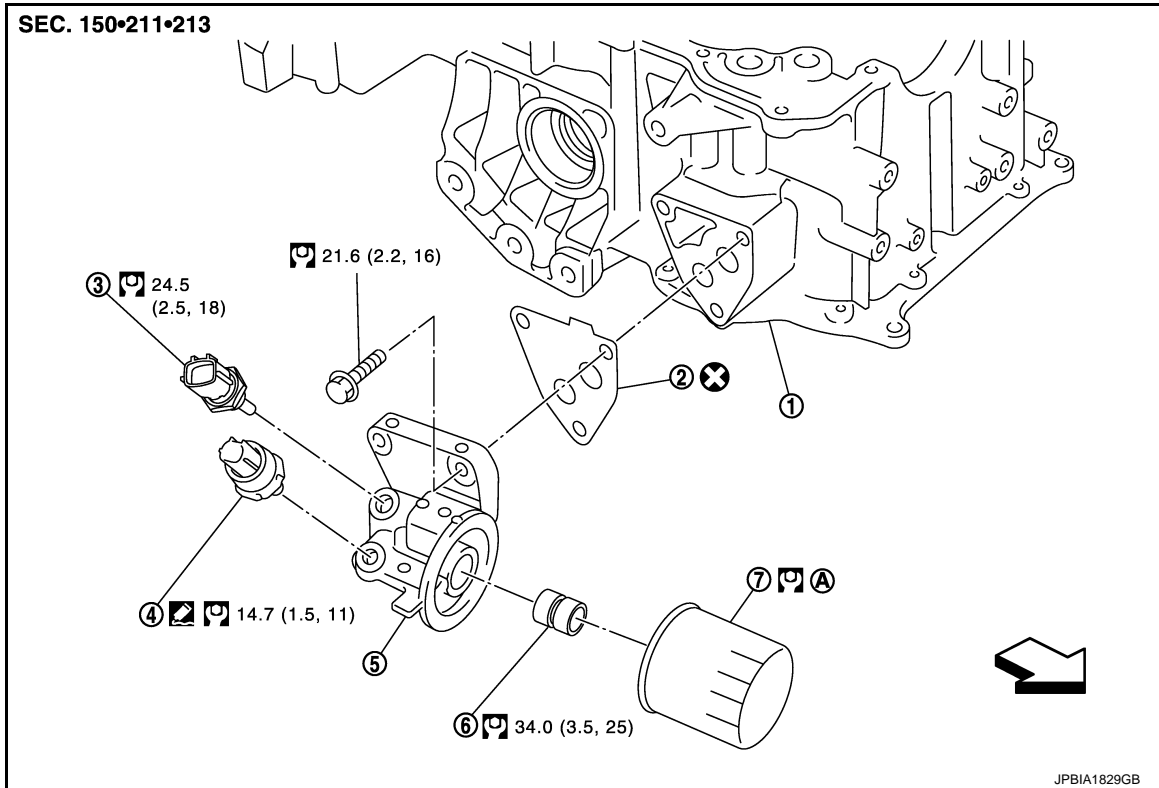

- | | | |
|-----------------------------------|-----------------------|---------------------------|
| 1. Oil pan (upper) | 2. Gasket | 3. Oil temperature sensor |
| 4. Oil pressure switch | 5. Oil filter bracket | 6. Connector bolt |
| 7. Oil filter | | |
| A. Refer to LU-10 | | |

↔ : Engine front

Refer to [GI-4. "Components"](#) for symbols in the figure.

Removal and Installation

INFOID:000000007457626

REMOVAL

WARNING:

Never get burn yourself, as engine oil may be hot.

1. Remove engine undercover, using a power tool.
2. Using the oil filter wrench [SST: KV10115801 (J-38956)], remove oil filter. Refer to [LU-10. "Removal and Installation"](#).

CAUTION:

Never spill engine oil on drive belt.

3. Disconnect oil pressure switch harness connector and oil temperature sensor harness connector.
4. Remove oil filter bracket from oil pan (upper).
5. Remove oil pressure switch and oil temperature sensor from oil filter bracket.

INSTALLATION

- Install oil pressure switch as follows:
 - Remove old liquid gasket adhering to oil filter bracket.
 - Apply liquid gasket and install oil pressure switch.

OIL FILTER BRACKET (AWD)

< REMOVAL AND INSTALLATION >

Use Genuine RTV Silicone Sealant or equivalent. Refer to [GI-22, "Recommended Chemical Products and Sealants"](#).

Inspection

INFOID:000000007457627

INSPECTION AFTER INSTALLATION

1. Check the engine oil level and add engine oil. Refer to [LU-7, "Inspection"](#).
2. Start the engine, and check there is no leakage of engine oil.
3. Stop the engine and wait for 10 minutes.
4. Check the engine oil level again. Refer to [LU-7, "Inspection"](#).

A

LU

C

D

E

F

G

H

I

J

K

L

M

N

O

P

OIL PUMP

< UNIT DISASSEMBLY AND ASSEMBLY >

UNIT DISASSEMBLY AND ASSEMBLY

OIL PUMP

Exploded View

INFOID:000000007457628

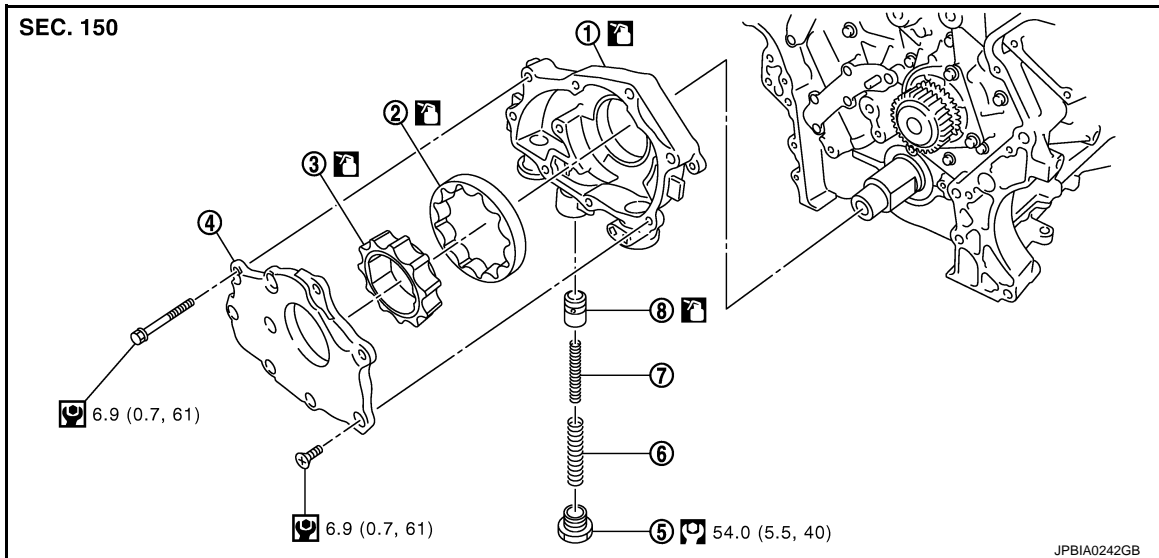

- | | | |
|---------------------------|-------------------------|---------------------------|
| 1. Oil pump body | 2. Oil pump outer rotor | 3. Oil pump inner rotor |
| 4. Oil pump cover | 5. Regulator valve plug | 6. Regulator valve spring |
| 7. Regulator valve spring | 8. Regulator valve | |

Refer to [GI-4, "Components"](#) for symbols in the figure.

Disassembly and Assembly

INFOID:000000007457629

DISASSEMBLY

1. Remove oil pan (lower) and oil strainer. Refer to [EM-43, "Exploded View \(2WD\)"](#) (2WD models) or [EM-44, "Exploded View \(AWD\)"](#) (AWD models).
2. Remove oil pan (upper). Refer to [EM-98, "2WD : Exploded View"](#) (2WD models) or [EM-101, "AWD : Exploded View"](#) (AWD models).
3. Remove front timing chain case and timing chain (primary). Refer to [EM-50, "Exploded View"](#).
4. Remove oil pump assembly.
5. Remove oil pump cover.
6. Remove oil pump inner rotor and oil pump outer rotor from oil pump body.
7. After removing regulator valve plug, remove regulator valve spring and regulator valve.

ASSEMBLY

Note the following, and assemble in the reverse order of disassembly.

CAUTION:

Before assembly, apply new engine oil to the parts as instructed in the figure.

OIL PUMP

< UNIT DISASSEMBLY AND ASSEMBLY >

- Install oil pump inner rotor with the groove faced to oil pump cover side.

- A : Oil pump body side
- B : Oil pump cover side
- C : Groove

- When installing oil pump, align crankshaft flat faces with oil pump inner rotor flat faces.

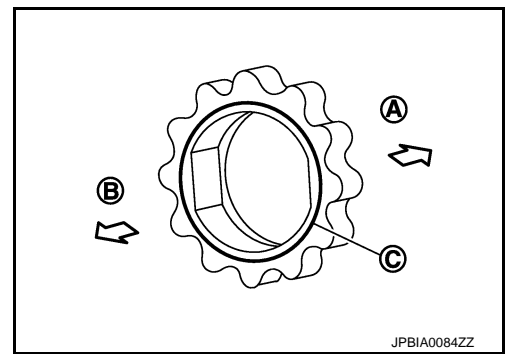

INFOID:000000007457630

Inspection

INSPECTION AFTER DISASSEMBLY

Oil Pump Clearance

- Measure the clearance with feeler gauge (C).
- Clearance between oil pump outer rotor and oil pump body [position (B)]

Standard : Refer to [LU-17, "Oil Pump"](#).

- Tip clearance between oil pump inner rotor and oil pump outer rotor [position (A)]

Standard : Refer to [LU-17, "Oil Pump"](#).

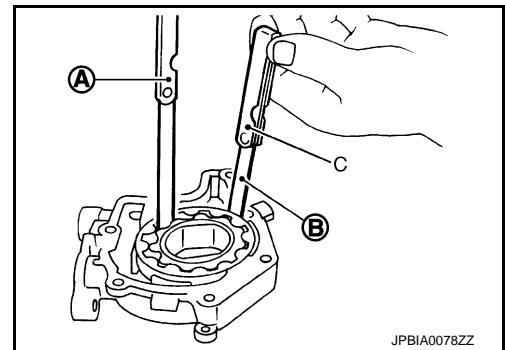

- Measure the clearance with feeler gauge and straightedge (A).
- Side clearance between oil pump inner rotor and oil pump body [position (C)]

Standard : Refer to [LU-17, "Oil Pump"](#).

- Side clearance between oil pump outer rotor and oil pump body [position (B)]

Standard : Refer to [LU-17, "Oil Pump"](#).

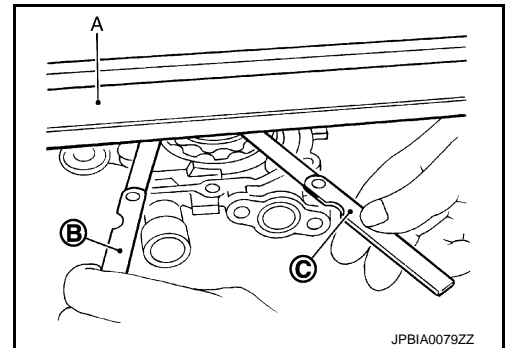

- Calculate the clearance between oil pump inner rotor and oil pump body as follows:

OIL PUMP BODY INNER DIAMETER

- Measure the inner diameter of oil pump body with inside micrometer. [position (A)]

OIL PUMP INNER ROTOR OUTER DIAMETER

- Measure the outer diameter of protruded portion of oil pump inner rotor (1) with micrometer. [position (B)]

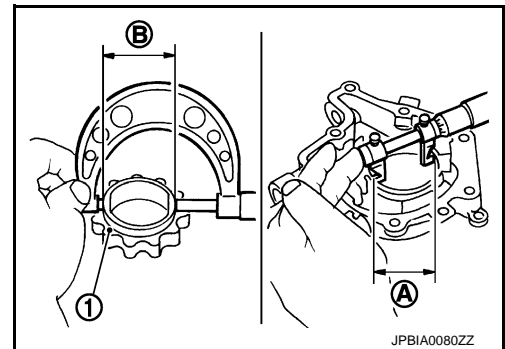

OIL PUMP INNER ROTOR TO OIL PUMP BODY CLEARANCE

- (Clearance) = (Oil pump body inner diameter) – (Oil pump inner rotor outer diameter)

OIL PUMP

< UNIT DISASSEMBLY AND ASSEMBLY >

Standard : Refer to [LU-17, "Oil Pump"](#).

- If measured/calculated values are out of the standard, replace oil pump assembly.

Regulator Valve Clearance

(Clearance) = (Regulator valve hole diameter) – (Regulator valve outer diameter)

1 : Regulator valve

2 : Oil pump body

Standard : Refer to [LU-17, "Regulator Valve"](#).

- If the calculated value is out of the standard, replace oil pump assembly.

CAUTION:

- Coat regulator valve with engine oil.
- Check that it falls smoothly into valve hole by its own weight.

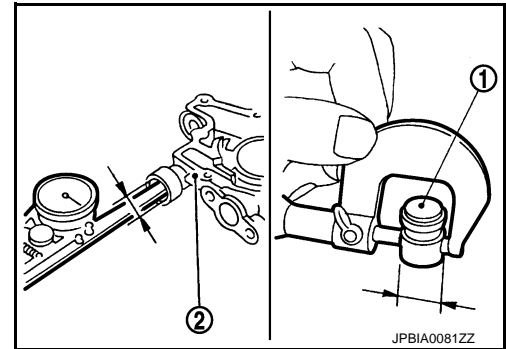

INSPECTION AFTER INSTALLATION

1. Check the engine oil level. Refer to [LU-7, "Inspection"](#).
2. Start the engine, and check there is no leakage of engine oil.
3. Stop the engine and wait for 10 minutes.
4. Check the engine oil level and adjust the level. Refer to [LU-7, "Inspection"](#).

SERVICE DATA AND SPECIFICATIONS (SDS)

< SERVICE DATA AND SPECIFICATIONS (SDS)

SERVICE DATA AND SPECIFICATIONS (SDS)

SERVICE DATA AND SPECIFICATIONS (SDS)

Periodical Maintenance Specification

INFOID:0000000007457631

ENGINE OIL CAPACITY (APPROXIMATELY)

Unit: ℓ (US qt, Imp qt)

Drain and refill	With oil filter change	4.9 (5-1/8, 4-1/4)
	Without oil filter change	4.6 (4-7/8, 4)
Dry engine (Overhaul)		5.7 (6, 5)

Engine Oil Pressure

INFOID:0000000007457632

Unit: kPa (kg/cm², psi)

Engine speed	Approximate discharge pressure*
Idle speed	More than 98 (1.0, 14)
2,000 rpm	More than 294 (3.0, 43)

*: Engine oil temperature at 80°C (176°F)

Oil Pump

INFOID:0000000007457633

Unit: mm (in)

Oil pump body to oil pump outer rotor radial clearance	0.114 - 0.260 (0.0045 - 0.0102)
Oil pump inner rotor to oil pump outer rotor tip clearance	Below 0.180 (0.0071)
Oil pump body to oil pump inner rotor axial clearance	0.030 - 0.070 (0.0012 - 0.0028)
Oil pump body to oil pump outer rotor axial clearance	0.030 - 0.090 (0.0012 - 0.0035)
Oil pump inner rotor to brazed portion of housing clearance	0.045 - 0.091 (0.0018 - 0.0036)

Regulator Valve

INFOID:0000000007457634

Unit: mm (in)

Regulator valve to oil pump cover clearance	0.040 - 0.097 (0.0016 - 0.0038)
---	---------------------------------