

SECTION **CHG**
CHARGING SYSTEM

A
B
C
D
E
F
G
H
I
J
K
L
N
O
P

CONTENTS

BASIC INSPECTION	3	CHARGING SYSTEM	23
DIAGNOSIS AND REPAIR WORK FLOW	3	Symptom Table	23
Work Flow (With EXP-800 NI or GR8-1200 NI)	3	PRECAUTION	24
Work Flow (Without EXP-800 NI or GR8-1200 NI).....	7	PRECAUTIONS	24
SYSTEM DESCRIPTION	10	Precaution for Supplemental Restraint System (SRS) "AIR BAG" and "SEAT BELT PRE-TENSIONER"	24
CHARGING SYSTEM	10	Precaution for Power Generation Voltage Variable Control System	24
System Diagram	10	PREPARATION	25
System Description	10	PREPARATION	25
Component Parts Location	10	Special Service Tools	25
Component Description	11	Commercial Service Tools	25
POWER GENERATION VOLTAGE VARIABLE CONTROL SYSTEM	12	PERIODIC MAINTENANCE	26
System Diagram	12	CHARGING SYSTEM PRELIMINARY INSPECTION	26
System Description	12	Inspection Procedure	26
Component Parts Location	12	POWER GENERATION VOLTAGE VARIABLE CONTROL SYSTEM OPERATION INSPECTION	27
Component Description	13	Inspection Procedure	27
DTC/CIRCUIT DIAGNOSIS	14	REMOVAL AND INSTALLATION	29
B TERMINAL CIRCUIT	14	ALTERNATOR	29
Description	14	2WD	29
Diagnosis Procedure	14	2WD : Exploded View	29
L TERMINAL CIRCUIT (OPEN)	15	2WD : Removal and Installation	30
Description	15	2WD : Inspection	31
Diagnosis Procedure	15	AWD	31
L TERMINAL CIRCUIT (SHORT)	17	AWD : Exploded View	31
Description	17	AWD : Removal and Installation	33
Diagnosis Procedure	17	AWD : Inspection	34
S TERMINAL CIRCUIT	18	CHARGING SYSTEM	19
Description	18	Wiring Diagram - CHARGING SYSTEM -	19
Diagnosis Procedure	18	SYMPTOM DIAGNOSIS	23

CHG

SERVICE DATA AND SPECIFICATIONS
(SDS) 35

SERVICE DATA AND SPECIFICATIONS
(SDS) 35
Alternator 35

DIAGNOSIS AND REPAIR WORK FLOW

< BASIC INSPECTION >

BASIC INSPECTION

DIAGNOSIS AND REPAIR WORK FLOW

Work Flow (With EXP-800 NI or GR8-1200 NI)

INFOID:000000008285684

CHARGING SYSTEM DIAGNOSIS WITH EXP-800 NI OR GR8-1200 NI

To test the charging system, use the following special service tools:

- EXP-800 NI Battery and electrical diagnostic analyzer
- GR8-1200 NI Multitasking battery and electrical diagnostic station

NOTE:

Refer to the applicable Instruction Manual for proper charging system diagnosis procedures.

A
B
C
D
E
F
G
H
I
J
K
L
N
O
P

CHG

DIAGNOSIS AND REPAIR WORK FLOW

< BASIC INSPECTION >

OVERALL SEQUENCE

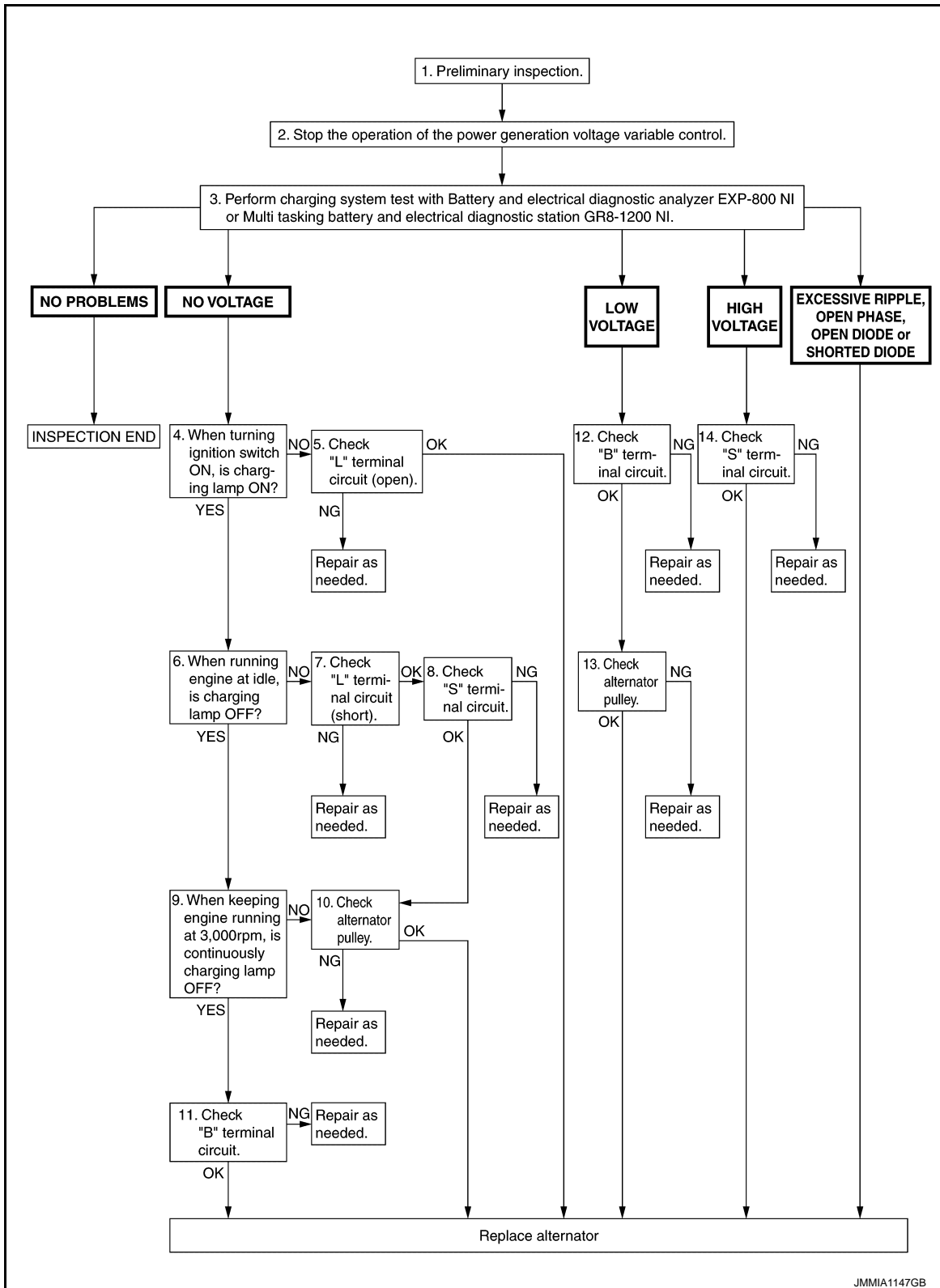

DETAILED FLOW

NOTE:

To ensure a complete and thorough diagnosis, the battery, starter and alternator test segments must be done as a set from start to finish.

1. PRELIMINARY INSPECTION

Perform the preliminary inspection. Refer to [CHG-26, "Inspection Procedure"](#).

DIAGNOSIS AND REPAIR WORK FLOW

< BASIC INSPECTION >

>> GO TO 2.

2. STOP POWER GENERATION VOLTAGE VARIABLE CONTROL SYSTEM

Stop the operation of the power generation voltage variable control in either of the following procedures.

- After selecting “ENGINE” of “SELECT SYSTEM” using CONSULT, set the DUTY value of “ALTERNATOR DUTY” to 0 % by selecting “ALTERNATOR DUTY” of “Active Test”. Continue “Active Test” until the end of inspection. (When the DUTY value is 0 or 100 %, the normal power generation is performed according to the characteristic of the IC voltage regulator of the alternator.)
- Turn the ignition switch OFF, and disconnect the battery current sensor connector. [However, DTC (P1550 - P1554) of the engine might remain. After finishing the inspection, connect the battery current sensor connector and erase the self-diagnosis results history of the engine using CONSULT.]

>> GO TO 3.

3. DIAGNOSIS WITH EXP-800 NI OR GR8-1200 NI

Perform the charging system test using Multitasking battery and electrical diagnostic station GR8-1200 NI or Battery and electrical diagnostic analyzer EXP-800 NI. Refer to the applicable Instruction Manual for proper testing procedures.

Test result

NO PROBLEMS>>Charging system is normal and will also show “DIODE RIPPLE” test result.

NO VOLTAGE>>GO TO 4.

LOW VOLTAGE>>GO TO 12.

HIGH VOLTAGE>>GO TO 14.

EXCESSIVE RIPPLE, OPEN PHASE, OPEN DIODE or SHORTED DIODE>>Replace the alternator. Perform “DIODE RIPPLE” test again using Multitasking battery and electrical diagnostic station GR8-1200 NI or Battery and electrical diagnostic analyzer EXP-800 NI to confirm repair.

4. INSPECTION WITH CHARGE WARNING LAMP (IGNITION SWITCH IS ON)

Turn the ignition switch ON.

Does the charge warning lamp illuminate?

YES >> GO TO 6.

NO >> GO TO 5.

5. “L” TERMINAL CIRCUIT (OPEN) INSPECTION

Check “L” terminal circuit (open). Refer to [CHG-15, "Diagnosis Procedure"](#).

Is the “L” terminal circuit normal?

YES >> Replace alternator.

NO >> Repair as needed.

6. INSPECTION WITH CHARGE WARNING LAMP (IDLING)

Start the engine and run it at idle.

Does the charge warning lamp turn OFF?

YES >> GO TO 9.

NO >> GO TO 7.

7. “L” TERMINAL CIRCUIT (SHORT) INSPECTION

Check “L” terminal circuit (short). Refer to [CHG-17, "Diagnosis Procedure"](#).

Is the “L” terminal circuit normal?

YES >> GO TO 8.

NO >> Repair as needed.

8. “S” TERMINAL CIRCUIT INSPECTION

Check “S” terminal circuit. Refer to [CHG-18, "Diagnosis Procedure"](#).

Is the “S” terminal circuit normal?

YES >> GO TO 10.

NO >> Repair as needed.

A

B

C

D

E

F

G

H

I

J

K

L

CHG

N

O

P

DIAGNOSIS AND REPAIR WORK FLOW

< BASIC INSPECTION >

9. INSPECTION WITH CHARGE WARNING LAMP (ENGINE AT 3,000 RPM)

Increase and maintain the engine speed at 3,000 rpm.

Does the charge warning lamp remain off?

YES >> GO TO 11.

NO >> GO TO 10.

10. INSPECTION OF ALTERNATOR PULLEY

Check alternator pulley. Refer to [CHG-31, "2WD : Inspection"](#) (2WD) or [CHG-34, "AWD : Inspection"](#) (AWD).

Is alternator pulley normal?

YES >> Replace alternator.

NO >> Repair as needed.

11. "B" TERMINAL CIRCUIT INSPECTION

Check "B" terminal circuit. Refer to [CHG-14, "Diagnosis Procedure"](#).

Is "B" terminal circuit normal?

YES >> Replace alternator.

NO >> Repair as needed.

12. "B" TERMINAL CIRCUIT INSPECTION

Check "B" terminal circuit. Refer to [CHG-14, "Diagnosis Procedure"](#).

Is "B" terminal circuit normal?

YES >> GO TO 13.

NO >> Repair as needed.

13. INSPECTION OF ALTERNATOR PULLEY

Check alternator pulley. Refer to [CHG-31, "2WD : Inspection"](#) (2WD) or [CHG-34, "AWD : Inspection"](#) (AWD).

Is alternator pulley normal?

YES >> Replace alternator.

NO >> Repair as needed.

14. "S" TERMINAL CIRCUIT INSPECTION

Check "S" terminal circuit. Refer to [CHG-18, "Diagnosis Procedure"](#).

Is the "S" terminal circuit normal?

YES >> Replace alternator.

NO >> Repair as needed.

DIAGNOSIS AND REPAIR WORK FLOW

< BASIC INSPECTION >

Work Flow (Without EXP-800 NI or GR8-1200 NI)

INFOID:000000010463830

OVERALL SEQUENCE

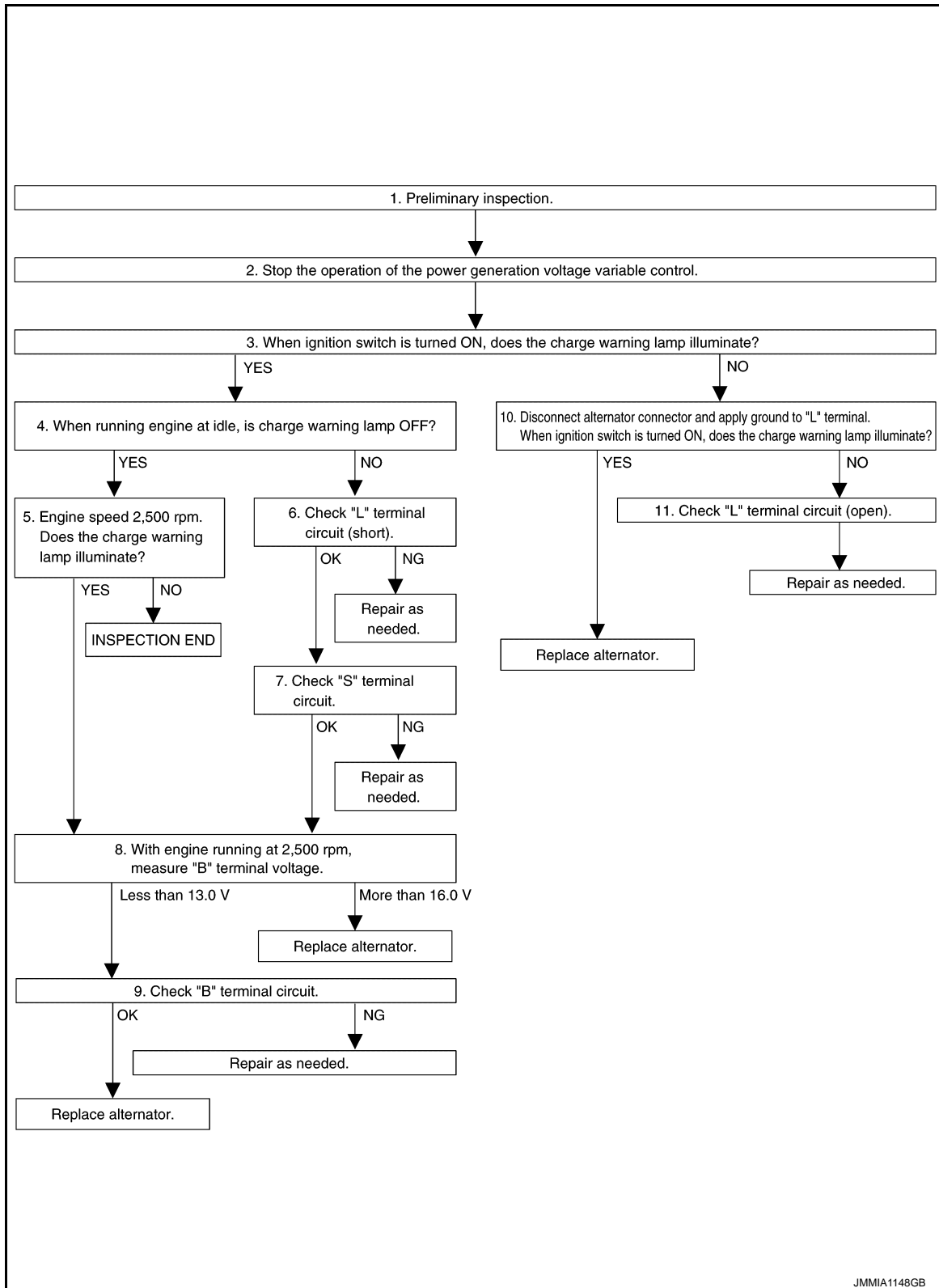

DETAILED FLOW

1. PRELIMINARY INSPECTION

Perform the preliminary inspection. Refer to [CHG-26, "Inspection Procedure"](#).

A
B
C
D
E
F
G
H
I
J
K
L
N
O
P

CHG

DIAGNOSIS AND REPAIR WORK FLOW

< BASIC INSPECTION >

>> GO TO 2.

2. STOP POWER GENERATION VOLTAGE VARIABLE CONTROL SYSTEM

Stop the operation of the power generation voltage variable control in either of the following procedures.

- After selecting "ENGINE" of "SELECT SYSTEM" using CONSULT, set the DUTY value of "ALTERNATOR DUTY" to 0 % by selecting "ALTERNATOR DUTY" of "Active Test". Continue "Active Test" until the end of inspection. (When the DUTY value is 0 or 100 %, the normal power generation is performed according to the characteristic of the IC regulator of the alternator.)
- Turn the ignition switch OFF, and disconnect the battery current sensor connector. [However, DTC (P1550 - P1554) of the engine might remain. After finishing the inspection, connect the battery current sensor connector and erase the self-diagnostic results history of the engine using CONSULT.]

>> GO TO 3.

3. INSPECTION WITH CHARGE WARNING LAMP (IGNITION SWITCH IS TURNED ON)

When ignition switch is turned ON

Does the charge warning lamp illuminate?

YES >> GO TO 4.

NO >> GO TO 10.

4. INSPECTION WITH CHARGE WARNING LAMP (IDLING)

Start the engine and run it at idle.

Does the charge warning lamp turn OFF?

YES >> GO TO 5.

NO >> GO TO 6.

5. INSPECTION WITH CHARGE WARNING LAMP (ENGINE AT 2,500 RPM)

Increase and maintain the engine speed at 2,500 rpm.

Does the charge warning lamp illuminate?

YES >> GO TO 8.

NO >> INSPECTION END

6. "L" TERMINAL CIRCUIT (SHORT) INSPECTION

Check "L" terminal circuit (short). Refer to [CHG-17, "Diagnosis Procedure"](#).

Is the inspection result normal?

YES >> GO TO 7.

NO >> Repair as needed.

7. "S" TERMINAL CIRCUIT INSPECTION

Check "S" terminal circuit. Refer to [CHG-18, "Diagnosis Procedure"](#).

Is the inspection result normal?

YES >> GO TO 8.

NO >> Repair as needed.

8. MEASURE "B" TERMINAL VOLTAGE

Start engine. With engine running at 2,500 rpm, measure "B" terminal voltage.

What voltage does the measurement result show?

Less than 13.0 V >> GO TO 9.

More than 16.0 V >> Replace alternator. Refer to [CHG-30, "2WD : Removal and Installation"](#) (2WD) or [CHG-33, "AWD : Removal and Installation"](#) (AWD).

9. "B" TERMINAL CIRCUIT INSPECTION

Check "B" terminal circuit. Refer to [CHG-14, "Diagnosis Procedure"](#).

Is the inspection result normal?

YES >> Replace alternator. Refer to [CHG-30, "2WD : Removal and Installation"](#) (2WD) or [CHG-33, "AWD : Removal and Installation"](#) (AWD).

NO >> Repair as needed.

DIAGNOSIS AND REPAIR WORK FLOW

< BASIC INSPECTION >

10.INSPECTION WITH CHARGE WARNING LAMP (IGNITION SWITCH IS ON)

1. Disconnect alternator connector and apply ground to "L" terminal.
2. Turn the ignition switch ON.

Does the charge warning lamp illuminate?

YES >> Replace alternator. Refer to [CHG-30. "2WD : Removal and Installation"](#) (2WD) or [CHG-33. "AWD : Removal and Installation"](#) (AWD).

NO >> GO TO 11.

11.CHECK "L" TERMINAL CIRCUIT (OPEN)

Check "L" terminal circuit (open). Refer to [CHG-15. "Diagnosis Procedure"](#).

>> Repair as needed.

A
B
C
D
E
F
G
H
I
J
K
L
N
O
P

CHG

CHARGING SYSTEM

< SYSTEM DESCRIPTION >

SYSTEM DESCRIPTION

CHARGING SYSTEM

System Diagram

INFOID:000000008285685

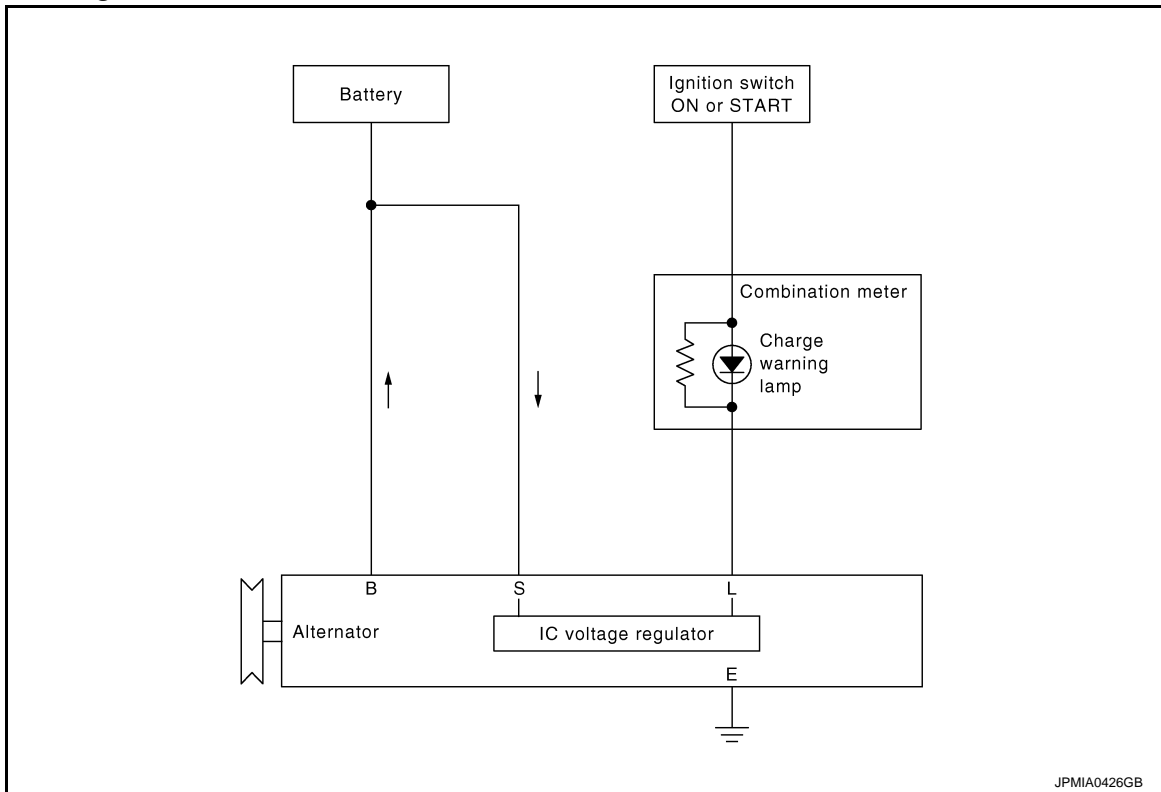

System Description

INFOID:000000008285686

The alternator provides DC voltage to operate the vehicle's electrical system and to keep the battery charged. The voltage output is controlled by the IC voltage regulator.

Component Parts Location

INFOID:000000008285687

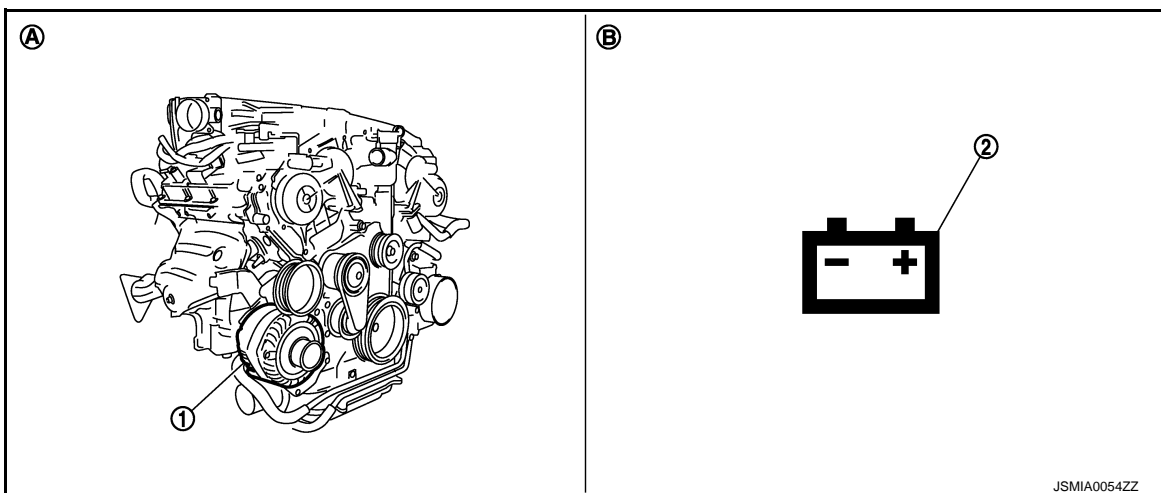

1. Alternator

2. Charge warning lamp

A. Engine

B. Combination meter

CHARGING SYSTEM

< SYSTEM DESCRIPTION >

Component Description

INFOID:000000008285688

Component part	Description
Alternator	The alternator provides DC voltage to operate the vehicle electrical system and to keep the battery charged.
Combination meter (Charge warning lamp)	The IC voltage regulator warning function activates to illuminate the charge warning lamp, if any of the following symptoms occur while alternator is operating: <ul style="list-style-type: none">• Excessive voltage is produced.• No voltage is produced.

A

B

C

D

E

F

G

H

I

J

K

L

CHG

N

O

P

POWER GENERATION VOLTAGE VARIABLE CONTROL SYSTEM

< SYSTEM DESCRIPTION >

POWER GENERATION VOLTAGE VARIABLE CONTROL SYSTEM

System Diagram

INFOID:000000008285689

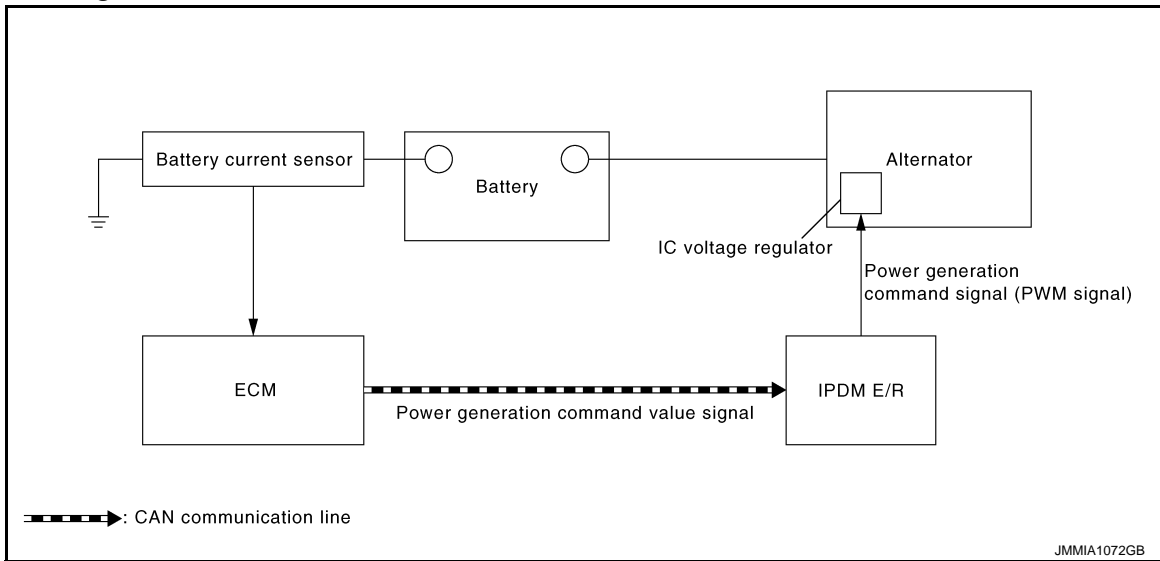

System Description

INFOID:000000008285690

By performing the power generation voltage variable control, the engine load due to the power generation of the alternator is reduced and fuel consumption is decreased.

NOTE:

When any malfunction is detected in the power generation voltage variable control system, the power generation is performed according to the characteristic of the IC voltage regulator of the alternator.

Component Parts Location

INFOID:000000008285691



- | | | |
|--------------------------------|---------------------|---------------------------|
| 1. Battery | 2. IPDM E/R | 3. Battery current sensor |
| 4. ECM | 5. Alternator | |
| A. Engine room dash panel (RH) | B. Behind glove box | C. Engine |

POWER GENERATION VOLTAGE VARIABLE CONTROL SYSTEM

< SYSTEM DESCRIPTION >

Component Description

INFOID:000000008285692

Component part	Description
Battery current sensor	Battery current sensor is installed to the battery cable at the negative terminal, and it detects the charging/discharging current of the battery and sends the voltage signal to ECM according to the current value.
ECM	Battery current sensor detects the charging/discharging current of the battery. ECM judges the battery condition based on this signal. ECM judges whether to perform the power generation voltage variable control according to the battery condition. When performing the power generation voltage variable control, ECM calculates the target power generation voltage according to the battery condition and sends the calculated value as the power generation command value to IPDM E/R.
IPDM E/R	IPDM E/R converts the received power generation command value into the power generation command signal (PWM signal) and sends it to the IC voltage regulator.
Alternator (IC voltage regulator)	IC voltage regulator controls the power generation voltage by the target power generation voltage based on the received power generation command signal. When there is no power generation command signal, the alternator performs the normal power generation according to the characteristic of the IC voltage regulator.

A
B
C
D
E
F
G
H
I
J
K
L

CHG

N
O
P

B TERMINAL CIRCUIT

< DTC/CIRCUIT DIAGNOSIS >

DTC/CIRCUIT DIAGNOSIS

B TERMINAL CIRCUIT

Description

INFOID:000000008285693

"B" terminal circuit supplies power to charge the battery and to operate the vehicle's electrical system.

Diagnosis Procedure

INFOID:000000008285694

1. CHECK "B" TERMINAL CONNECTION

1. Turn ignition switch OFF.
2. Check if "B" terminal is clean and tight.

Is the inspection result normal?

YES >> GO TO 2.

NO >> Repair "B" terminal connection. Confirm repair by performing complete Charging system test using EXP-800 NI or GR8-1200 NI (if available). Refer to the applicable Instruction Manual for proper testing procedures.

2. CHECK "B" TERMINAL CIRCUIT

Check voltage between alternator "B" terminal and ground.

Terminals			Voltage (Approx.)
(+)	(-)		
Alternator "B" terminal	Terminal		
E203	1	Ground	Battery voltage

Is the inspection result normal?

YES >> GO TO 3.

NO >> Check harness for open between alternator and fusible link.

3. CHECK "B" TERMINAL CONNECTION (VOLTAGE DROP TEST)

1. Start engine, then engine running at idle and warm.
2. Check voltage between battery positive terminal and alternator "B" terminal.

Terminals			Voltage (Approx.)
(+)	(-)		
	Alternator "B" terminal	Terminal	
Battery positive terminal	E203	1	Less than 0.2 V

Is the inspection result normal?

YES >> "B" terminal circuit is normal. Refer to [CHG-3. "Work Flow \(With EXP-800 NI or GR8-1200 NI\)"](#) or [CHG-7. "Work Flow \(Without EXP-800 NI or GR8-1200 NI\)"](#).

NO >> Check harness between battery and alternator for poor continuity.

L TERMINAL CIRCUIT (OPEN)

< DTC/CIRCUIT DIAGNOSIS >

L TERMINAL CIRCUIT (OPEN)

Description

INFOID:000000008285695

The "L" terminal circuit controls the charge warning lamp. The charge warning lamp illuminates when the ignition switch is set to ON or START. When the alternator is providing sufficient voltage with the engine running, the charge warning lamp will go off. If the charge warning lamp illuminates with the engine running, a malfunction is indicated.

Diagnosis Procedure

INFOID:000000008285696

1. CHECK "L" TERMINAL CONNECTION

1. Turn ignition switch OFF.
2. Check if "L" terminal is clean and tight.

Is the inspection result normal?

YES >> GO TO 2.

NO >> Repair "L" terminal connection. Confirm repair by performing complete Charging system test using EXP-800 NI or GR8-1200 NI (if available). Refer to the applicable Instruction Manual for proper testing procedures.

2. CHECK "L" TERMINAL CIRCUIT (OPEN)

1. Disconnect alternator connector.
2. Apply ground to alternator harness connector terminal.
3. Check condition of the charge warning lamp with the ignition switch in the ON position.

Alternator harness connector	Terminal	Ground	Condition	
			Ignition switch position	Charge warning lamp
F36	2		ON	Illuminate

Does it illuminate?

YES >> "L" terminal circuit is normal. Refer to [CHG-3, "Work Flow \(With EXP-800 NI or GR8-1200 NI\)"](#) or [CHG-7, "Work Flow \(Without EXP-800 NI or GR8-1200 NI\)"](#).

NO >> GO TO 3.

3. CHECK HARNESS CONTINUITY (OPEN CIRCUIT)

1. Disconnect the battery cable from the negative terminal.
2. Disconnect the combination meter connector.
3. Check continuity between alternator harness connector and combination meter harness connector.

Alternator harness connector		Combination meter harness connector		Continuity
Connector No.	Terminal No.	Connector No.	Terminal No.	
F36	2	M53	6	Existed

Is the inspection result normal?

YES >> GO TO 4.

NO >> Repair the harness or connector.

4. CHECK HARNESS CONTINUITY (OPEN CIRCUIT)

Check continuity between combination meter harness connector and fuse block.

Combination meter harness connector		Fuse block		Continuity
Connector No.	Terminal No.	Connector No.	Terminal No.	
M53	21	M3	12C	Existed

Is the inspection result normal?

YES >> GO TO 5.

NO >> Repair the harness.

L TERMINAL CIRCUIT (OPEN)

< DTC/CIRCUIT DIAGNOSIS >

5. CHECK POWER SUPPLY CIRCUIT

1. Connect the battery cable to the negative terminal.
2. Check voltage between combination meter harness connector and ground.

Terminals		(-)	Condition	Voltage (Approx.)
(+)	Terminal			
Combination meter harness connector				
M53	21	Ground	When the ignition switch is in ON position	Battery voltage

Is the inspection result normal?

YES >> Replace combination meter.

NO >> Inspect the power supply circuit. Refer to [PG-44. "Wiring Diagram - IGNITION POWER SUPPLY -](#)
".

L TERMINAL CIRCUIT (SHORT)

< DTC/CIRCUIT DIAGNOSIS >

L TERMINAL CIRCUIT (SHORT)

Description

INFOID:000000008285697

The "L" terminal circuit controls the charge warning lamp. The charge warning lamp illuminates when the ignition switch is set to ON or START. When the alternator is providing sufficient voltage with the engine running, the charge warning lamp will go off. If the charge warning lamp illuminates with the engine running, a malfunction is indicated.

Diagnosis Procedure

INFOID:000000008285698

1. CHECK "L" TERMINAL CIRCUIT (SHORT)

1. Turn ignition switch OFF.
2. Disconnect alternator connector.
3. Turn ignition switch ON.

Does charge warning lamp illuminate?

YES >> GO TO 2.

NO >> Refer to [CHG-3. "Work Flow \(With EXP-800 NI or GR8-1200 NI\)"](#) or [CHG-7. "Work Flow \(Without EXP-800 NI or GR8-1200 NI\)"](#).

2. CHECK HARNESS CONTINUITY (SHORT CIRCUIT)

1. Turn the ignition switch OFF.
2. Disconnect the battery cable from the negative terminal.
3. Disconnect combination meter connector.
4. Check continuity between combination meter harness connector and ground.

Combination meter harness connector		Ground	Continuity
Connector No.	Terminal No.		
M53	6		Not existed

Is the inspection result normal?

YES >> Replace combination meter.

NO >> Repair the harness.

A
B
C
D
E
F
G
H
I
J
K
L

CHG

N
O
P

S TERMINAL CIRCUIT

< DTC/CIRCUIT DIAGNOSIS >

S TERMINAL CIRCUIT

Description

INFOID:000000008285699

The output voltage of the alternator is controlled by the IC voltage regulator at the "S" terminal detecting the input voltage.

The "S" terminal circuit detects the battery voltage to adjust the alternator output voltage with the IC voltage regulator.

Diagnosis Procedure

INFOID:000000008285700

1. CHECK "S" TERMINAL CONNECTION

1. Turn ignition switch OFF.
2. Check if "S" terminal is clean and tight.

Is the inspection result normal?

YES >> GO TO 2.

NO >> Repair "S" terminal connection. Confirm repair by performing complete Charging system test using EXP-800 NI or GR8-1200 NI (if available). Refer to the applicable Instruction Manual for proper testing procedures.

2. CHECK "S" TERMINAL CIRCUIT

Check voltage between alternator harness connector and ground.

Terminals		Voltage (Approx.)
(+)	(-)	
Alternator harness connector	Terminal	Battery voltage
F36	3	
	Ground	

Is the inspection result normal?

YES >> Refer to [CHG-3, "Work Flow \(With EXP-800 NI or GR8-1200 NI\)"](#) or [CHG-7, "Work Flow \(Without EXP-800 NI or GR8-1200 NI\)"](#).

NO >> Check harness for open between alternator and fuse.

CHARGING SYSTEM

< DTC/CIRCUIT DIAGNOSIS >

CHARGING SYSTEM

Wiring Diagram - CHARGING SYSTEM -

INFOID:000000008285701

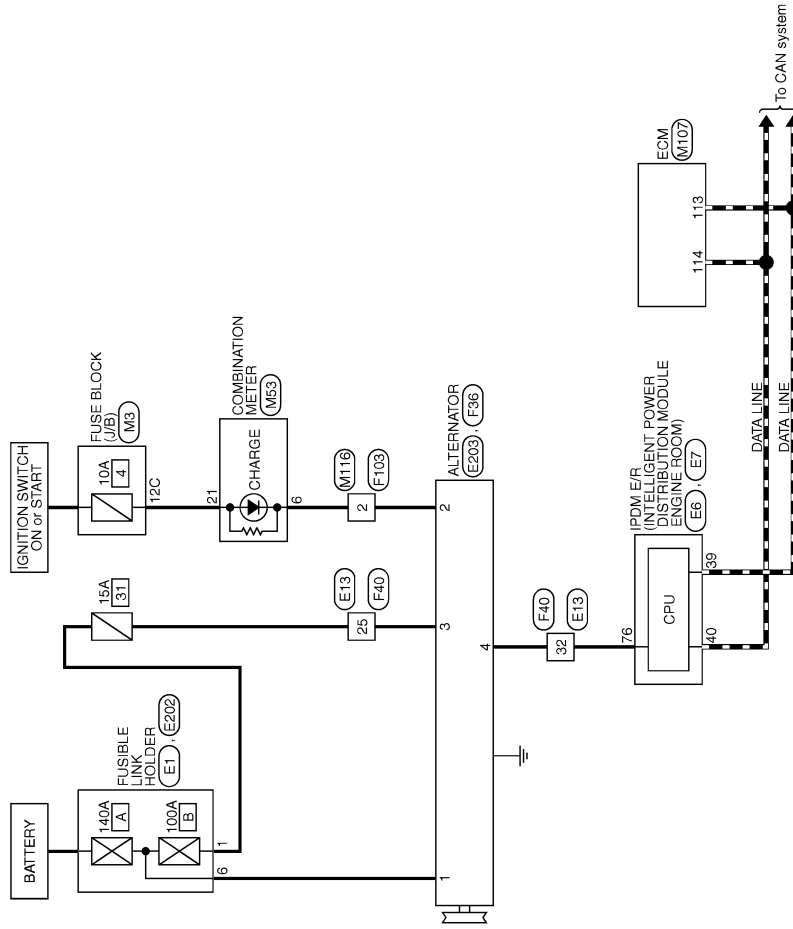

CHARGING SYSTEM

A
B
C
D
E
F
G
H
I
J
K
L
N
O
P

CHG

2012/06/11

JRMWD2721 GB

CHARGING SYSTEM

< DTC/CIRCUIT DIAGNOSIS >

CHARGING SYSTEM

Connector No.	E1
Connector Name	FUSIBLE LINK HOLDER
Connector Type	L02FBR-MC



Terminal No.	Color Of Wire	Signal Name [Specification]
1	R	-
2	W	-

Connector No.	E6
Connector Name	POWER INTELLIGENT POWER-DIS TRIBUTION MODULE (ENGINE ROOM)
Connector Type	TH08FM-MH



Terminal No.	Color Of Wire	Signal Name [Specification]
39	P	-
40	L	-
41	B/W	-
43	SB	-
44	BR	-
45	G	-
46	R	-

Connector No.	E7
Connector Name	POWER INTELLIGENT POWER-DIS TRIBUTION MODULE (ENGINE ROOM)
Connector Type	TH20FM-CS12-M4

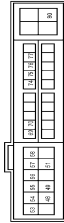

Terminal No.	Color Of Wire	Signal Name [Specification]
48	L	-
49	B/G	-
51	Y	-
53	W	-
54	P	-
55	SB	-
56	LG	-
57	G	-
58	V	-
69	BR	-
70	B/G	-
74	P	-
75	SB	-
76	Y	-
77	R	-
80	W	-

Connector No.	E13
Connector Name	WIRE TO WIRE
Connector Type	SAA3RMB-RS8-SH28



Terminal No.	Color Of Wire	Signal Name [Specification]
1	L/V	-
2	SHIELD	-
3	UB	-

Terminal No.	Color Of Wire	Signal Name [Specification]
4	SHIELD	-
5	BR	-
7	G	-
8	W	-
9	W	-
10	Y	-
11	P	-
12	SB	-
13	L	-
14	G	-
15	R	-
16	LG	-
18	Y	-
19	B/G	-
20	B	-
21	SB	-
22	W	-
23	L	-
24	G	-
25	LG	-
27	GR	-
28	V	-
29	P	-
30	R	-
31	BR	-
32	Y	-
33	G	-
34	B/G	-
37	SHIELD	-
38	L	-
39	P	-
40	R	-
41	W	-
42	LG	-
43	G	-
45	B/G	-
46	SHIELD	-
47	W	-
48	BR	-
49	G	-
50	B	-
51	SB	-
52	R	-

Connector No.	E202
Connector Name	FUSIBLE LINK HOLDER
Connector Type	24340-79905



Terminal No.	Color Of Wire	Signal Name [Specification]
6	R	-

Connector No.	E203
Connector Name	ALTERNATOR
Connector Type	24340-65745



Terminal No.	Color Of Wire	Signal Name [Specification]
1	R	-

Connector No.	F36
Connector Name	ALTERNATOR
Connector Type	HS03FB



JRMWE9741GB

CHARGING SYSTEM

< DTC/CIRCUIT DIAGNOSIS >

CHARGING SYSTEM

Terminal No.	Color Of Wire	Signal Name [Specification]
2	G	L
3	V	S
4	P	C

Connector No.	F40
Connector Name	WIRE TO WIRE
Connector Type	SAA36FB-RS8-SH28

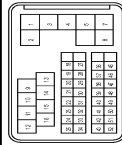

Terminal No.	Color Of Wire	Signal Name [Specification]
1	LY	-
2	SHIELD	-
3	LYB	-
4	SHIELD	-
5	BR	-
7	G	-
8	W	-
9	W	-
10	G	-
11	R	-
12	P	-
13	L	-
14	LG	-
15	BR	-
16	Y	-
18	LG	-
19	P	-
20	O	-
21	Y	-
22	G	-
23	Y	-
24	LG	-
25	V	-
27	GR	-
28	BR	-
29	L	-
30	P	-
31	R	-
32	W	-

33	SB	-
34	O	-
37	SHIELD	-
38	W	-
39	Y	-
40	G	-
41	B	-
42	GR	-
43	R	-
45	O	-
46	SHIELD	-
47	W/L	-
48	LG	-
49	OIL	-
50	L/Y	-
51	W	-
52	LG	-

Connector No.	F103
Connector Name	WIRE TO WIRE
Connector Type	TK36FM-NS10

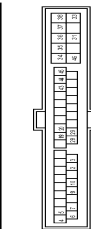

Terminal No.	Color Of Wire	Signal Name [Specification]
2	G	-
3	W	-
4	R	-
5	B	-
9	Y	-
10	GR	-
19	BG	-
20	O	-
28	B	-
29	LG	-
31	R	-
33	GR	-
34	B	-
35	L	-
36	P	-
37	Y	-

38	G	-
43	LG	-
44	O	-
45	Y	-
46	V	-

Connector No.	M3
Connector Name	FUSE BLOCK (JIB)
Connector Type	NS12FM-GS

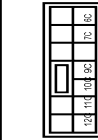

Terminal No.	Color Of Wire	Signal Name [Specification]
10C	L	-
11C	R	-
12C	BG	-
6C	R	-
7C	B	-
9C	BG	-

Connector No.	M53
Connector Name	COMBINATION METER
Connector Type	TH40FM-NH



Terminal No.	Color Of Wire	Signal Name [Specification]
1	GR	BATTERY POWER SUPPLY
2	LG	COMMUNICATION SIGNAL (METER AMP)
3	GR	COMMUNICATION SIGNAL (AMP-METER)
6	B	GROUND
7	BR	AIR BAG SIGNAL
10	G	SECURITY SIGNAL

15	B	GROUND
16	B	METER CONTROL SWITCH GROUND
19	B	ILL GND
20	R	ILL
21	BG	IGNITION SIGNAL
22	B	GROUND
24	BR	COMMUNICATION SIGNAL (LGD-AMP)
25	Y	COMMUNICATION SIGNAL (AMP-LOD)
26	R	VEHICLE SPEED SIGNAL (8-PULSE)
27	V	PARKING BRAKE SWITCH SIGNAL
28	W	BRAKE FLUID LEVEL SWITCH SIGNAL
29	SB	SEAT BELT BUCKLE SWITCH SIGNAL (DRIVER SIDE)
30	G	SEAT BELT BUCKLE SWITCH SIGNAL (PASSENGER SIDE)
31	L	WASHER LEVEL SWITCH SIGNAL
33	B	ILLUMINATION CONTROL SIGNAL
36	LG	SELECT SWITCH SIGNAL
37	SB	ENTER SWITCH SIGNAL
38	L	TRIP AB RESET SWITCH SIGNAL
39	P	ILLUMINATION CONTROL SWITCH SIGNAL (1)
40	BG	ILLUMINATION CONTROL SWITCH SIGNAL (2)

Connector No.	M107
Connector Name	ECM
Connector Type	IRH24FGY-R28-R-LH-Z

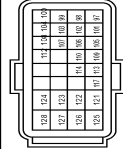

Terminal No.	Color Of Wire	Signal Name [Specification]
97	R	ACCELERATOR PEDAL POSITION SENSOR 1
98	P	ACCELERATOR PEDAL POSITION SENSOR 2 (W/VALVE)
98	Y	ACCELERATOR PEDAL POSITION SENSOR 2 (W/VALVE)
99	G	ACCELERATOR PEDAL POSITION SENSOR 2 (W/VALVE)
99	L	ACCELERATOR PEDAL POSITION SENSOR 2 (W/VALVE)
100	W	SENSOR GEAR AND ACCELERATOR GEAR POSITION SENSOR 1
101	SB	ASCD/CC STEERING SWITCH
102	LG	EWAP CONTROL SYSTEM PRESS SENSOR
103	G	SENSOR GEAR AND ACCELERATOR GEAR POSITION SENSOR 2
104	BR	SENSOR GEAR AND ACCELERATOR GEAR POSITION SENSOR 2 (W/VALVE)
104	GR	SENSOR GEAR AND ACCELERATOR GEAR POSITION SENSOR 2 (W/VALVE)
105	L	REFRIGERANT PRESS SENSOR
106	W	FUEL TANK TEMPERATURE SENSOR

A
B
C
D
E
F
G
H
I
J
K
L
CHG
N
O
P

JRMWE9742GB

CHARGING SYSTEM

< DTC/CIRCUIT DIAGNOSIS >

CHARGING SYSTEM

107	BG	SENSOR POWER SUPPLY/PERFORMANT PRESSURE SENSOR
108	Y	SENSOR GROUND (ASDC/CC STEERING SWITCH)
109	G	PNP Signal
110	R	ENGINE SPEED OUTPUT SIGNAL
112	V	SENSOR GROUND (EVM CONTROL SYSTEM PRESSURE SENSOR)
113	P	CAN COMMUNICATION LINE
114	L	CAN COMMUNICATION LINE
117	V	DATA LINK CONNECTOR
121	LG	EVAP CANISTER VENT CONTROL VALVE
122	P	STOP LAMP SWITCH
123	B	ECM GROUND
124	B	ECM GROUND
125	R	POWER SUPPLY FOR ECM
126	BR	ASDC/CC BRAKE SWITCH
127	B	ECM GROUND
128	B	ECM GROUND

Connector No.	M116
Connector Name	WIRE TO WIRE
Connector Type	TK38MM-NS10



Terminal No.	Color Of Wire	Signal Name [Specification]
2	P	-
3	L	-
4	R	-
5	B	-
9	R	-
10	R	-
19	BG	-
20	Y	-
28	B	-
29	LG	-
31	W	-
33	B	-
34	B	-
35	L	-
36	P	-
37	Y	-
38	G	-
43	P	-

44	L	-
45	BR	-
46	BG	-

JRMWE9743GB

CHARGING SYSTEM

< SYMPTOM DIAGNOSIS >

SYMPTOM DIAGNOSIS

CHARGING SYSTEM

Symptom Table

INFOID:000000008285702

Symptom	Reference
Discharged battery	
The charge warning lamp does not illuminate when the ignition switch is set to ON.	
The charge warning lamp does not turn OFF after the engine starts.	Refer to CHG-3, "Work Flow (With EXP-800 NI or GR8-1200 NI)" or CHG-7, "Work Flow (Without EXP-800 NI or GR8-1200 NI)" .
The charging warning lamp turns ON when increasing the engine speed.	

A

B

C

D

E

F

G

H

I

J

K

L

CHG

N

O

P

PRECAUTIONS

< PRECAUTION >

PRECAUTION

PRECAUTIONS

Precaution for Supplemental Restraint System (SRS) "AIR BAG" and "SEAT BELT PRE-TENSIONER"

INFOID:000000008285703

The Supplemental Restraint System such as "AIR BAG" and "SEAT BELT PRE-TENSIONER", used along with a front seat belt, helps to reduce the risk or severity of injury to the driver and front passenger for certain types of collision. This system includes seat belt switch inputs and dual stage front air bag modules. The SRS system uses the seat belt switches to determine the front air bag deployment, and may only deploy one front air bag, depending on the severity of a collision and whether the front occupants are belted or unbelted. Information necessary to service the system safely is included in the "SRS AIR BAG" and "SEAT BELT" of this Service Manual.

WARNING:

Always observe the following items for preventing accidental activation.

- To avoid rendering the SRS inoperative, which could increase the risk of personal injury or death in the event of a collision that would result in air bag inflation, all maintenance must be performed by an authorized NISSAN/INFINITI dealer.
- Improper maintenance, including incorrect removal and installation of the SRS, can lead to personal injury caused by unintentional activation of the system. For removal of Spiral Cable and Air Bag Module, see "SRS AIR BAG".
- Never use electrical test equipment on any circuit related to the SRS unless instructed to in this Service Manual. SRS wiring harnesses can be identified by yellow and/or orange harnesses or harness connectors.

PRECAUTIONS WHEN USING POWER TOOLS (AIR OR ELECTRIC) AND HAMMERS

WARNING:

Always observe the following items for preventing accidental activation.

- When working near the Air Bag Diagnosis Sensor Unit or other Air Bag System sensors with the ignition ON or engine running, never use air or electric power tools or strike near the sensor(s) with a hammer. Heavy vibration could activate the sensor(s) and deploy the air bag(s), possibly causing serious injury.
- When using air or electric power tools or hammers, always switch the ignition OFF, disconnect the battery, and wait at least 3 minutes before performing any service.

Precaution for Power Generation Voltage Variable Control System

INFOID:000000008285706

CAUTION:

For this model, the battery current sensor that is installed to the battery cable at the negative terminal measures the charging/discharging current of the battery, and performs various controls. If the electrical component or the ground wire is connected directly to the battery terminal, the current other than that being measured with the battery current sensor is charging to or discharging from the battery. This condition causes the malfunction of the control, and then the battery discharge may occur. Do not connect the electrical component or the ground wire directly to the battery terminal.

PREPARATION

< PREPARATION >

PREPARATION

PREPARATION

Special Service Tools

INFOID:000000008285707

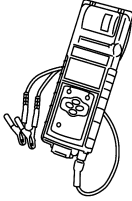
Tool number (Kent-Moore No.) Tool name	Description
<p>— (—) Model GR8-1200 NI Multitasking battery and electrical diagnostic station</p>  <p style="text-align: center;">AWIA1239ZZ</p>	<p>Tests batteries, starting and charging systems and charges batteries. For operating instructions, refer to diagnostic station instruction manual.</p>
<p>— (—) Model EXP-800 NI Battery and electrical diagnostic analyzer</p>  <p style="text-align: center;">JSMIA0806ZZ</p>	<p>Tests batteries and charging systems. For operating instructions, refer to diagnostic analyzer instruction manual.</p>

Commercial Service Tools

INFOID:000000008285708

Tool name	Description
<p>Power tool</p>  <p style="text-align: center;">PIIB1407E</p>	<p>Loosening bolts, nuts and screws</p>

A

B

C

D

E

F

G

H

I

J

K

L

CHG

N

O

P

CHARGING SYSTEM PRELIMINARY INSPECTION

< PERIODIC MAINTENANCE >

PERIODIC MAINTENANCE

CHARGING SYSTEM PRELIMINARY INSPECTION

Inspection Procedure

INFOID:000000008285709

1. CHECK BATTERY TERMINALS CONNECTION

Check if battery terminals are clean and tight.

Is the inspection result normal?

YES >> GO TO 2.

NO >> Repair battery terminals connection.

2. CHECK FUSE

Check for blown fuse and fusible link.

Unit	Power source (Power supply terminals)	Fuse No.
Alternator	Battery ("S" terminal)	31
Combination meter	Ignition switch ON ("L" terminal)	4

Is the inspection result normal?

YES >> GO TO 3.

NO >> Be sure to eliminate the cause of malfunction before installing new fuse.

3. CHECK "E" TERMINAL CONNECTION (ALTERNATOR GROUND)

Check if "E" terminal (alternator ground) is clean and tight.

Is the inspection result normal?

YES >> GO TO 4.

NO >> Repair "E" terminal (alternator ground) connection.

4. CHECK DRIVE BELT TENSION

Check drive belt tension. Refer to [EM-20. "Checking"](#).

Is the inspection result normal?

YES >> INSPECTION END

NO >> Repair as needed.

POWER GENERATION VOLTAGE VARIABLE CONTROL SYSTEM OPERATION INSPECTION

< PERIODIC MAINTENANCE >

POWER GENERATION VOLTAGE VARIABLE CONTROL SYSTEM OPERATION INSPECTION

Inspection Procedure

INFOID:000000008285710

CAUTION:

When performing this inspection, always use a charged battery that has completed the battery inspection. (When the charging rate of the battery is low, the response speed of the voltage change will become slow. This can cause an incorrect inspection.)

1. CHECK ECM (CONSULT)

Perform ECM self-diagnosis with CONSULT. Refer to [EC-146, "CONSULT Function"](#).

Self-diagnostic results content

No malfunction detected>> GO TO 2.

Malfunction detected>> Check applicable parts, and repair or replace corresponding parts.

2. CHECK OPERATION OF POWER GENERATION VOLTAGE VARIABLE CONTROL SYSTEM

1. Connect CONSULT and start the engine.
2. The selector lever is in "P" or "N" position and all of the electric loads and A/C, etc. are turned OFF.
3. Select "ALTERNATOR DUTY" at "Active Test" of "ENGINE", and then check the value of "BATTERY VOLT" monitor when DUTY value of "ALTERNATOR DUTY" is set to 40.0%.

"BATTERY VOLT"

2 seconds after setting the DUTY value of "ALTERNATOR DUTY" to 40.0% : 12 - 13.6 V

4. Check the value of "BATTERY VOLT" monitor when DUTY value of "ALTERNATOR DUTY" is set to 80.0%.

"BATTERY VOLT"

20 seconds after setting the DUTY value of "ALTERNATOR DUTY" to 80.0% : +0.5 V or more against the value of "BATTERY VOLT" monitor when DUTY value is 40.0%

Is the measurement value within the specification?

YES >> INSPECTION END

NO >> GO TO 3.

3. CHECK IPDM E/R (CONSULT)

Perform IPDM E/R self-diagnosis with CONSULT. Refer to [PCS-11, "CONSULT Function \(IPDM E/R\)"](#).

Self-diagnostic results content

No malfunction detected>> GO TO 4.

Malfunction detected>> Check applicable parts, and repair or replace corresponding parts.

4. CHECK HARNESS BETWEEN ALTERNATOR AND IPDM E/R

1. Turn ignition switch OFF.
2. Disconnect alternator connector and IPDM E/R connector.
3. Check continuity between alternator harness connector and IPDM E/R harness connector.

Alternator harness connector		IPDM E/R harness connector		Continuity
Connector	Terminal	Connector	Terminal	
F36	4	E7	76	Existed

4. Check continuity between alternator harness connector and ground.

POWER GENERATION VOLTAGE VARIABLE CONTROL SYSTEM OPERATION INSPECTION

< PERIODIC MAINTENANCE >

Alternator harness connector		Ground	Continuity
Connector	Terminal		
F36	4		Not existed

Is the inspection result normal?

YES >> Replace IPDM E/R.

NO >> Repair harness or connector between IPDM E/R and alternator.

ALTERNATOR

< REMOVAL AND INSTALLATION >

REMOVAL AND INSTALLATION

ALTERNATOR

2WD

2WD : Exploded View

INFOID:000000008285711

REMOVAL

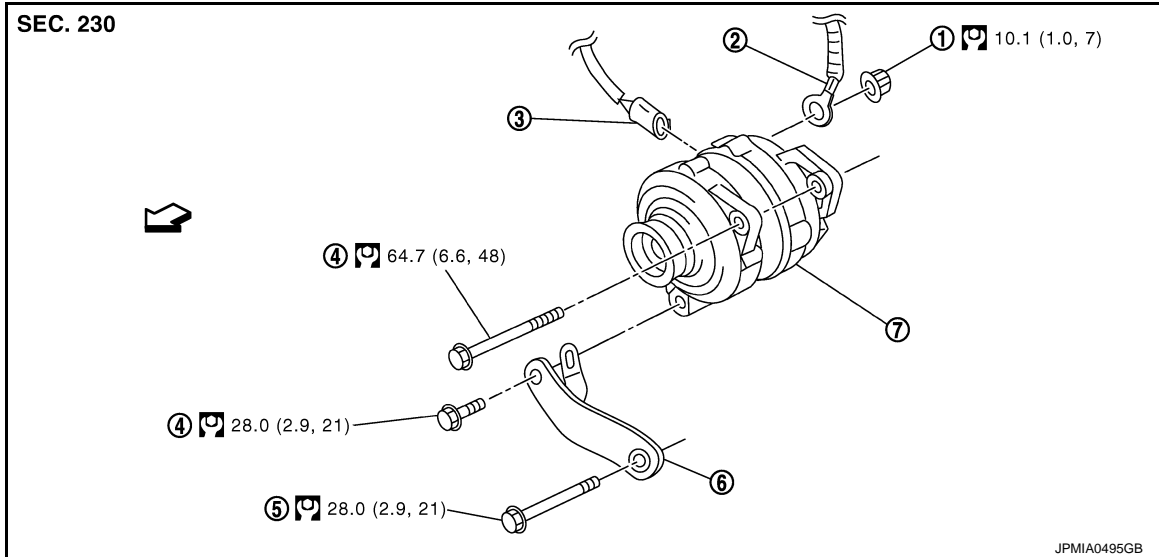

- | | | |
|-----------------------------|----------------------------------|-------------------------|
| 1. "B" terminal nut | 2. "B" terminal harness | 3. Alternator connector |
| 4. Alternator mounting bolt | 5. Alternator stay mounting bolt | 6. Alternator stay |
| 7. Alternator | | |

↔ : Engine front

🔧 : N-m (kg-m, ft-lb)

DISASSEMBLY

A
B
C
D
E
F
G
H
I
J
K
L
N
O
P

CHG

ALTERNATOR

< REMOVAL AND INSTALLATION >

Type: A003TJ1991B

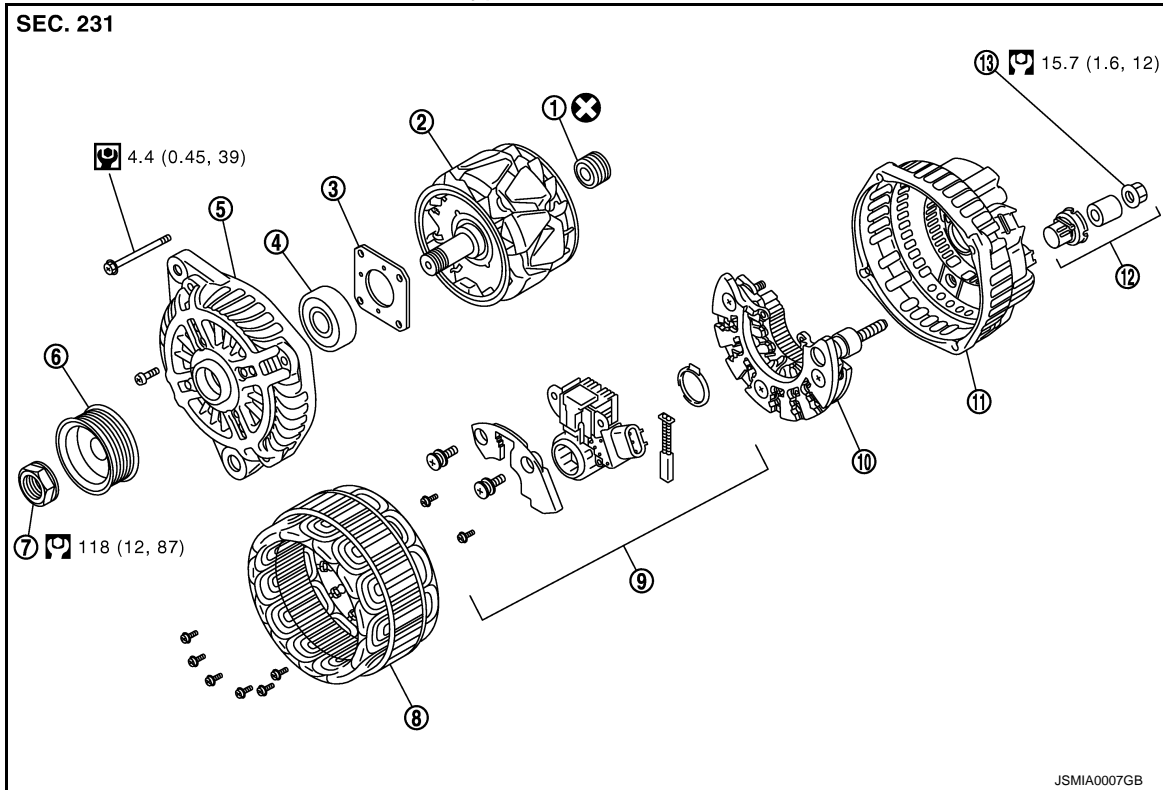

- | | | |
|----------------------|---------------------------|----------------------------------|
| 1. Rear bearing | 2. Rotor assembly | 3. Retainer |
| 4. Front bearing | 5. Front bracket assembly | 6. Pulley |
| 7. Pulley nut | 8. Stator assembly | 9. IC voltage regulator assembly |
| 10. Diode assembly | 11. Rear bracket assembly | 12. Terminal set |
| 13. "B" terminal nut | | |

⊗ : Always replace after every disassembly.

Ⓜ : N-m (kg-m, in-lb)

Ⓜ : N-m (kg-m, ft-lb)

2WD : Removal and Installation

INFOID:000000008285712

REMOVAL

1. Disconnect the battery cable from the negative terminal. Refer to [PG-99. "Removal and Installation"](#).
2. Remove engine front undercover, using power tools.
3. Remove stabilizer clamp nuts (A) and move the stabilizer (1).

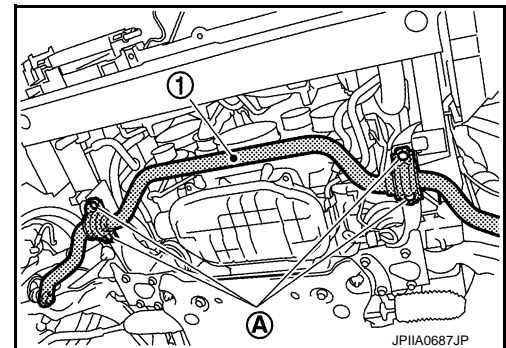

4. Remove radiator cooling fan assembly. Refer to [CO-13. "Exploded View"](#).
5. Remove drive belt. Refer to [EM-20. "Removal and Installation"](#).

ALTERNATOR

< REMOVAL AND INSTALLATION >

6. Disconnect alternator connector (1).
7. Remove "B" terminal nut (2).
8. Remove the harness bracket bolts (A).

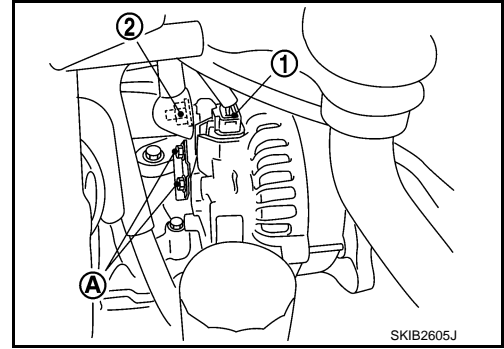

9. Remove oil pressure switch harness clip (C) from alternator stay (1).
10. Disconnect oil pressure switch connector (D) and oil temperature sensor connector (E).
11. Remove alternator mounting bolt (B) and alternator stay mounting bolt (F) using power tools, then remove alternator stay.
12. Remove alternator mounting bolt (A), using power tools.

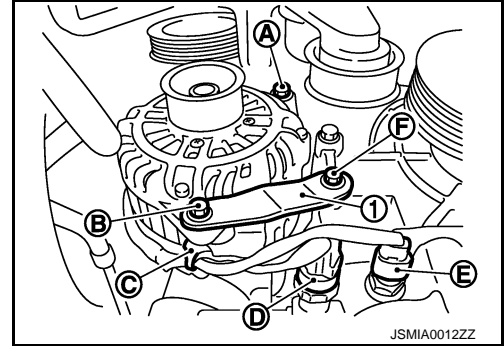

13. Remove alternator assembly downward from the vehicle.

INSTALLATION

Note the following items, and then install in the reverse order of removal.

CAUTION:

- Be careful to tighten "B" terminal nut to the specified torque.
- Install alternator, and check tension of belt. Refer to [EM-20, "Checking"](#).
- For this model, the power generation voltage variable control system that controls the power generation voltage of the alternator has been adopted. Therefore, the power generation voltage variable control system operation inspection should be performed after replacing the alternator, and then check that the system operates normally. Refer to [CHG-27, "Inspection Procedure"](#).

2WD : Inspection

INFOID:000000008285713

ALTERNATOR PULLEY INSPECTION

Perform the following.

- Make sure that alternator pulley does not rattle.
- Make sure that alternator pulley nut is tight. Refer to [CHG-29, "2WD : Exploded View"](#).

AWD

AWD : Exploded View

INFOID:000000008285714

REMOVAL

A
B
C
D
E
F
G
H
I
J
K
L
N
O
P

CHG

ALTERNATOR

< REMOVAL AND INSTALLATION >

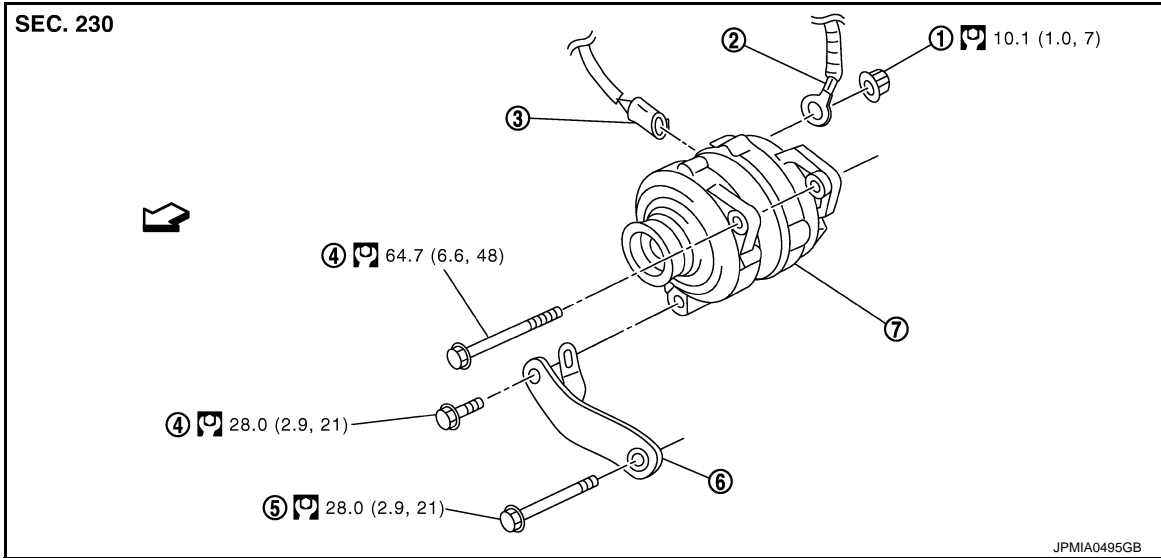

- | | | |
|-----------------------------|----------------------------------|-------------------------|
| 1. "B" terminal nut | 2. "B" terminal harness | 3. Alternator connector |
| 4. Alternator mounting bolt | 5. Alternator stay mounting bolt | 6. Alternator stay |
| 7. Alternator | | |

⇐ : Engine front

⊞ : N-m (kg-m, ft-lb)

DISASSEMBLY

Type: A003TJ1991B

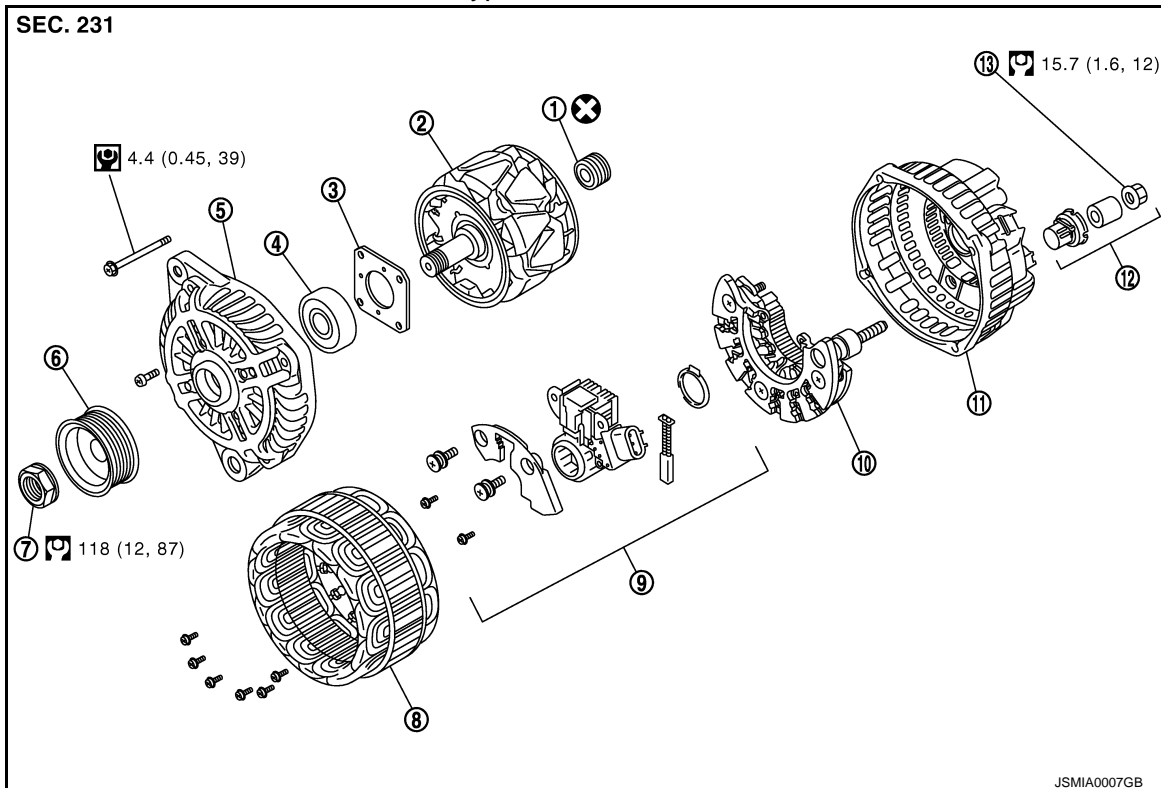

- | | | |
|--------------------|---------------------------|----------------------------------|
| 1. Rear bearing | 2. Rotor assembly | 3. Retainer |
| 4. Front bearing | 5. Front bracket assembly | 6. Pulley |
| 7. Pulley nut | 8. Stator assembly | 9. IC voltage regulator assembly |
| 10. Diode assembly | 11. Rear bracket assembly | 12. Terminal set |
| | | 13. Terminal set |

ALTERNATOR

< REMOVAL AND INSTALLATION >

13. "B" terminal nut

Refer to [GI-4, "Components"](#) for symbols in the figure.

⊗ : Always replace after every disassembly.

🔧 : N-m (kg-m, in-lb)

🔧 : N-m (kg-m, ft-lb)

AWD : Removal and Installation

INFOID:000000008285715

REMOVAL

1. Disconnect the battery cable from the negative terminal. Refer to [PG-99, "Removal and Installation"](#).
2. Remove air cleaner case. Refer to [EM-27, "Exploded View"](#).
3. Disconnect power steering oil pressure sensor connector (A).
4. Remove the clip (B) from the harness bracket (1) and "B" terminal harness from the clip (C).

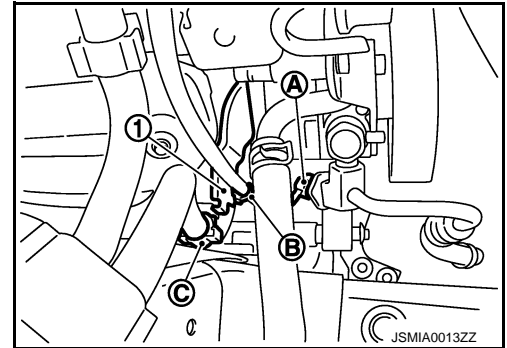

5. Remove engine undercover, using power tools.
6. Remove radiator cooling fan assembly. Refer to [CO-13, "Exploded View"](#).
7. Remove drive belt. Refer to [EM-20, "Removal and Installation"](#).
8. Remove alternator mounting bolt (B) and alternator stay mounting bolt (C) using power tools, then remove alternator stay (1).
9. Remove alternator mounting bolt (A), using power tools.

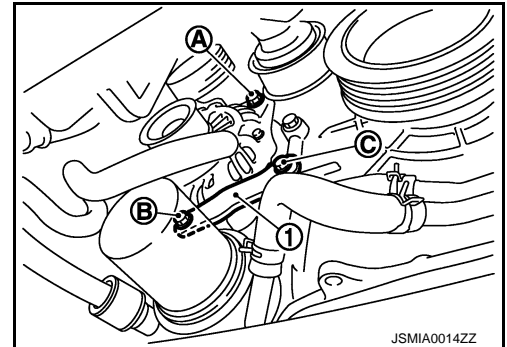

10. Pull and turn alternator, and then remove the harness bracket bolts (A).
11. Disconnect alternator connector (1).
12. Remove "B" terminal nut (2).

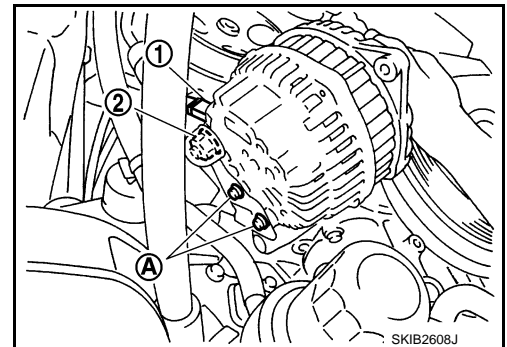

A
B
C
D
E
F
G
H
I
J
K
L
CHG
N
O
P

ALTERNATOR

< REMOVAL AND INSTALLATION >

13. Remove power steering oil pump mounting bolts (1) and power steering oil pump hose bracket bolts (2).

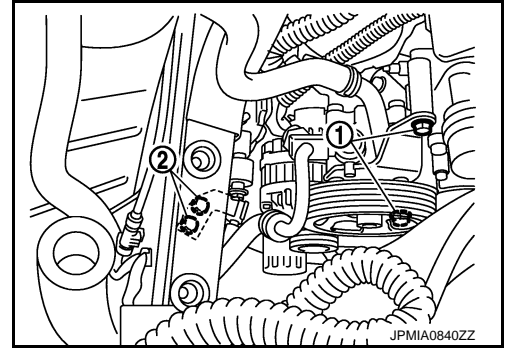

14. Move a power steering pump (1) and reservoir tank (2) forward.

⇐ : Vehicle front

15. Remove alternator assembly upward from the vehicle.

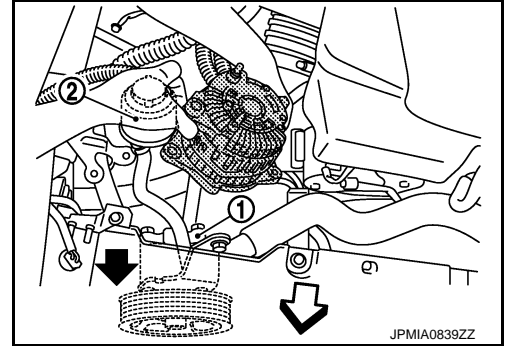

INSTALLATION

Note the following items, and then install in the reverse order of removal.

CAUTION:

- Be careful to tighten "B" terminal nut to the specified torque.
- Install alternator, and check tension of belt. Refer to [EM-20, "Checking"](#).
- For this model, the power generation voltage variable control system that controls the power generation voltage of the alternator has been adopted. Therefore, the power generation voltage variable control system operation inspection should be performed after replacing the alternator, and then check that the system operates normally. Refer to [CHG-27, "Inspection Procedure"](#).

AWD : Inspection

INFOID:000000008285716

ALTERNATOR PULLEY INSPECTION

Perform the following.

- Make sure that alternator pulley does not rattle.
- Make sure that alternator pulley nut is tight. Refer to [CHG-31, "AWD : Exploded View"](#).

SERVICE DATA AND SPECIFICATIONS (SDS)

< SERVICE DATA AND SPECIFICATIONS (SDS)

SERVICE DATA AND SPECIFICATIONS (SDS)

SERVICE DATA AND SPECIFICATIONS (SDS)

Alternator

INFOID:0000000008285717

Type		A003TJ1991B
		MITSUBISHI make
Nominal rating	[V - A]	12 -130
Ground polarity		Negative
Minimum revolution under no-load (When 13.5 V is applied)	[rpm]	Less than 1,300
Hot output current (When 13.5 V is applied)	[A/rpm]	More than 108/2,500 More than 124/5,000
Regulated output voltage	[V]	14.1 - 14.7*

*: Adjustment range of power generation voltage variable control is 11.4 - 15.6 V.

A
B
C
D
E
F
G
H
I
J
K
L
N
O
P

CHG