

SECTION **ATC**

AUTOMATIC AIR CONDITIONER

A
B
C
D
E
F
G
H
I
J
K
L
M
N
O
P

CONTENTS

<p>SERVICE INFORMATION 3</p> <p>PRECAUTIONS 3</p> <p style="padding-left: 20px;">Precaution for Supplemental Restraint System (SRS) "AIR BAG" and "SEAT BELT PRE-TENSIONER"3</p> <p style="padding-left: 20px;">Precaution Necessary for Steering Wheel Rotation After Battery Disconnect3</p> <p style="padding-left: 20px;">Precaution for Procedure without Cowl Top Cover....4</p> <p style="padding-left: 20px;">Precaution for Working with HFC-134a (R-134a).....4</p> <p style="padding-left: 20px;">General Refrigerant Precaution4</p> <p style="padding-left: 20px;">Precaution for Refrigerant Connection5</p> <p style="padding-left: 20px;">Precaution for Service of Compressor9</p> <p style="padding-left: 20px;">Precaution for Service Equipment9</p> <p style="padding-left: 20px;">Precaution for Leak Detection Dye 11</p> <p>PREPARATION13</p> <p style="padding-left: 20px;">Special Service Tool 13</p> <p style="padding-left: 20px;">HFC-134a (R-134a) Service Tool and Equipment... 13</p> <p style="padding-left: 20px;">Commercial Service Tool 16</p> <p>REFRIGERATION SYSTEM17</p> <p style="padding-left: 20px;">Refrigerant Cycle 17</p> <p style="padding-left: 20px;">Refrigerant System Protection 17</p> <p style="padding-left: 20px;">V-6 Variable Displacement Compressor 17</p> <p style="padding-left: 20px;">Component Part Location21</p> <p>LUBRICANT22</p> <p style="padding-left: 20px;">Maintenance of Lubricant Quantity in Compressor...22</p> <p>AIR CONDITIONER CONTROL24</p> <p style="padding-left: 20px;">Description of Air Conditioner LAN Control System24</p> <p style="padding-left: 20px;">System Construction24</p> <p style="padding-left: 20px;">Description of Control System27</p> <p style="padding-left: 20px;">Control Operation27</p> <p style="padding-left: 20px;">Fail-Safe Function28</p> <p style="padding-left: 20px;">Discharge Air Flow29</p> <p style="padding-left: 20px;">System Description30</p> <p style="padding-left: 20px;">CAN Communication System Description30</p> <p>TROUBLE DIAGNOSIS32</p>	<p>CONSULT-III Function32</p> <p>How to Perform Trouble Diagnosis for Quick and Accurate Repair32</p> <p>Component Parts and Harness Connector Location34</p> <p>Schematic36</p> <p>Wiring Diagram - A/C -37</p> <p>Auto Amp. Terminal and Reference Value42</p> <p>Self-Diagnosis Function43</p> <p>Operational Check50</p> <p>Power Supply and Ground Circuit for Auto Amp52</p> <p>LAN System Circuit54</p> <p>Mode Door Motor Circuit57</p> <p>Air Mix Door Motor Circuit59</p> <p>Air Mix Door Motor PBR Circuit62</p> <p>Intake Door Motor Circuit62</p> <p>Blower Motor Circuit64</p> <p>Magnet Clutch Circuit69</p> <p>Insufficient Cooling75</p> <p>Insufficient Heating82</p> <p>Noise83</p> <p>Self-Diagnosis84</p> <p>Memory Function85</p> <p>Ambient Sensor Circuit86</p> <p>In-vehicle Sensor Circuit88</p> <p>Sunload Sensor Circuit91</p> <p>Intake Sensor Circuit94</p> <p>CONTROLLER97</p> <p style="padding-left: 20px;">Removal and Installation of A/C and AV Switch97</p> <p>AUTO AMP98</p> <p style="padding-left: 20px;">Removal and Installation of Unified Meter and A/C Amp98</p> <p>AMBIENT SENSOR99</p> <p style="padding-left: 20px;">Removal and Installation99</p> <p>IN-VEHICLE SENSOR 100</p> <p style="padding-left: 20px;">Removal and Installation 100</p> <p>SUNLOAD SENSOR 101</p>
--	---

ATC

Removal and Installation	101	Component	121
INTAKE SENSOR	102	Removal and Installation of Compressor	123
Removal and Installation	102	Removal and Installation of Compressor Clutch ..	125
BLOWER UNIT	103	Removal and Installation of Low-Pressure Flexi- ble Hose	128
Removal and Installation	103	Removal and Installation of High-pressure Flexi- ble Hose	129
Disassembly and Assembly	104	Removal and Installation of Low-Pressure Pipe 1 (Engine Compartment)	131
BLOWER MOTOR	105	Removal and Installation of High-pressure Pipe 1 and 2 (Engine Compartment)	132
Removal and Installation	105	Removal and Installation of Low-Pressure Pipe 2 and High-pressure Pipe 3	133
INTAKE DOOR MOTOR	106	Removal and Installation of Liquid Tank	134
Removal and Installation	106	Removal and Installation of Condenser	135
IN-CABIN MICROFILTER	107	Removal and Installation of Refrigerant Pressure Sensor	137
Removal and Installation	107	Removal and Installation of Evaporator	137
HEATER & COOLING UNIT ASSEMBLY	108	Removal and Installation of Expansion Valve	138
Removal and Installation	108	Checking of Refrigerant Leaks	138
Disassembly and Assembly	111	Checking System for Leaks Using the Fluorescent Leak Detector	138
MODE DOOR MOTOR	113	Dye Injection	139
Removal and Installation	113	Electrical Leak Detector	139
AIR MIX DOOR MOTOR	114		
Removal and Installation	114		
HEATER CORE	115		
Removal and Installation	115		
DUCTS AND GRILLES	116		
Removal and Installation	116		
REFRIGERANT LINES	120		
HFC-134a (R-134a) Service Procedure	120		
		SERVICE DATA AND SPECIFICATIONS	
		(SDS)	142
		Compressor	142
		Lubricant	142
		Refrigerant	142
		Engine Idling Speed	142
		Belt Tension	142

PRECAUTIONS

< SERVICE INFORMATION >

SERVICE INFORMATION

PRECAUTIONS

Precaution for Supplemental Restraint System (SRS) "AIR BAG" and "SEAT BELT PRE-TENSIONER"

INFOID:000000001612929

The Supplemental Restraint System such as "AIR BAG" and "SEAT BELT PRE-TENSIONER", used along with a front seat belt, helps to reduce the risk or severity of injury to the driver and front passenger for certain types of collision. This system includes seat belt switch inputs and dual stage front air bag modules. The SRS system uses the seat belt switches to determine the front air bag deployment, and may only deploy one front air bag, depending on the severity of a collision and whether the front occupants are belted or unbelted. Information necessary to service the system safely is included in the "SUPPLEMENTAL RESTRAINT SYSTEM" and "SEAT BELTS" of this Service Manual.

WARNING:

- To avoid rendering the SRS inoperative, which could increase the risk of personal injury or death in the event of a collision which would result in air bag inflation, all maintenance must be performed by an authorized NISSAN/INFINITI dealer.
- Improper maintenance, including incorrect removal and installation of the SRS, can lead to personal injury caused by unintentional activation of the system. For removal of Spiral Cable and Air Bag Module, see the "SUPPLEMENTAL RESTRAINT SYSTEM".
- Do not use electrical test equipment on any circuit related to the SRS unless instructed to in this Service Manual. SRS wiring harnesses can be identified by yellow and/or orange harnesses or harness connectors.

Precaution Necessary for Steering Wheel Rotation After Battery Disconnect

INFOID:000000001612931

NOTE:

- This Procedure is applied only to models with Intelligent Key system and NVIS/IVIS (NISSAN/INFINITI VEHICLE IMMOBILIZER SYSTEM - NATS).
- Remove and install all control units after disconnecting both battery cables with the ignition knob in the "LOCK" position.
- Always use CONSULT-III to perform self-diagnosis as a part of each function inspection after finishing work. If DTC is detected, perform trouble diagnosis according to self-diagnostic results.

For models equipped with the Intelligent Key system and NVIS/IVIS, an electrically controlled steering lock mechanism is adopted on the key cylinder.

For this reason, if the battery is disconnected or if the battery is discharged, the steering wheel will lock and steering wheel rotation will become impossible.

If steering wheel rotation is required when battery power is interrupted, follow the procedure below before starting the repair operation.

OPERATION PROCEDURE

1. Connect both battery cables.

NOTE:

Supply power using jumper cables if battery is discharged.

2. Use the Intelligent Key or mechanical key to turn the ignition switch to the "ACC" position. At this time, the steering lock will be released.
3. Disconnect both battery cables. The steering lock will remain released and the steering wheel can be rotated.
4. Perform the necessary repair operation.
5. When the repair work is completed, return the ignition switch to the "LOCK" position before connecting the battery cables. (At this time, the steering lock mechanism will engage.)
6. Perform a self-diagnosis check of all control units using CONSULT-III.

PRECAUTIONS

< SERVICE INFORMATION >

Precaution for Procedure without Cowl Top Cover

INFOID:000000001612932

When performing the procedure after removing cowl top cover, cover the lower end of windshield with urethane, etc.

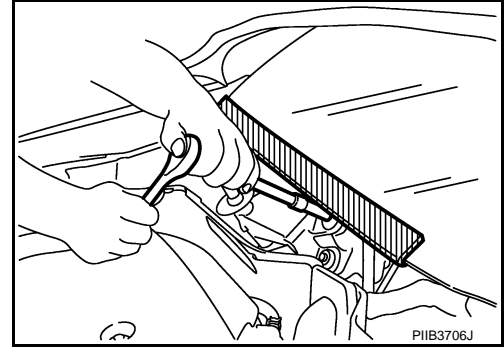

Precaution for Working with HFC-134a (R-134a)

INFOID:000000001328153

CAUTION:

- CFC-12 (R-12) refrigerant and HFC-134a (R-134a) refrigerant are not compatible. If the refrigerants are mixed and compressor malfunction is likely to occur, refer to “CONTAMINATED REFRIGERANT” below. To determine the purity of HFC-134a (R-134a) in the vehicle and recovery tank, use Refrigerant Recovery/Recycling Recharging equipment and Refrigerant Identifier.
- Use only specified lubricant for the HFC-134a (R-134a) A/C system and HFC-134a (R-134a) components. If lubricant other than that specified is used, compressor malfunction is likely to occur.
- The specified HFC-134a (R-134a) lubricant rapidly absorbs moisture from the atmosphere. The following handling precautions must be observed:
 - When removing refrigerant components from a vehicle, immediately cap (seal) the component to minimize the entry of moisture from the atmosphere.
 - When installing refrigerant components to a vehicle, never remove the caps (unseal) until just before connecting the components. Connect all refrigerant loop components as quickly as possible to minimize the entry of moisture into system.
 - Only use the specified lubricant from a sealed container. Immediately reseal containers of lubricant. Without proper sealing, lubricant will become moisture saturated and should not be used.
 - Never allow lubricant (Nissan A/C System Oil Type S) to come in contact with styrene foam parts. Damage may result.

CONTAMINATED REFRIGERANT

If a refrigerant other than pure HFC-134a (R-134a) is identified in a vehicle, take appropriate steps shown below:

- Explain to the customer that environmental regulations prohibit the release of contaminated refrigerant into the atmosphere.
- Explain that recovery of the contaminated refrigerant could damage service equipment and refrigerant supply.
- Suggest the customer return the vehicle to the location of previous service where the contamination may have occurred.
- In case of repairing, recover the refrigerant using only **dedicated equipment and containers. Never recover contaminated refrigerant into the existing service equipment.** If the facility does not have dedicated recovery equipment, contact a local refrigerant product retailer for available service. This refrigerant must be disposed of in accordance with all federal and local regulations. In addition, replacement of all refrigerant system components on the vehicle is recommended.
- If the vehicle is within the warranty period, the air conditioner warranty is void. Please contact Nissan Customer Affairs for further assistance.

General Refrigerant Precaution

INFOID:000000001328154

WARNING:

- Avoid breathing A/C refrigerant and lubricant vapor or mist. Exposure may irritate eyes, nose and throat. Remove HFC-134a (R-134a) from the A/C system, using certified service equipment meeting requirements of SAE J-2210 [HFC-134a (R-134a) recycling equipment], or J-2209 [HFC-134a (R-134a) recovery equipment]. If accidental system discharge occurs, ventilate work area before resuming service. Additional health and safety information may be obtained from refrigerant and lubricant manufacturers.

PRECAUTIONS

< SERVICE INFORMATION >

- Never release refrigerant into the air. Use approved recovery/recycling equipment to capture the refrigerant every time an air conditioning system is discharged.
- Always wear eye and hand protection (goggles and gloves) when working with any refrigerant or air conditioning system.
- Never store or heat refrigerant containers above 52°C (126°F).
- Never heat a refrigerant container with an open flame; if container warming is required, place the bottom of the container in a warm pail of water.
- Never intentionally drop, puncture, or incinerate refrigerant containers.
- Keep refrigerant away from open flames: poisonous gas will be produced if refrigerant burns.
- Refrigerant will displace oxygen, therefore be certain to work in well ventilated areas to prevent suffocation.
- Never pressure test or leak test HFC-134a (R-134a) service equipment and/or vehicle air conditioning systems with compressed air during repair. Some mixtures of air and HFC-134a (R-134a) have been shown to be combustible at elevated pressures. These mixtures, if ignited, may cause injury or property damage. Additional health and safety information may be obtained from refrigerant manufacturers.

Precaution for Refrigerant Connection

INFOID:000000001328155

A new type refrigerant connection has been introduced to all refrigerant lines except the following location.

- Expansion valve to evaporator
- Refrigerant pressure sensor to condenser

ABOUT ONE-TOUCH JOINT

Description

- One-touch joints are pipe joints which do not require tools during piping connection.
- Unlike conventional connection methods using union nuts and flanges, controlling tightening torque at connection point is not necessary.
- When removing a pipe joint, use a disconnecter.

COMPONENT PARTS

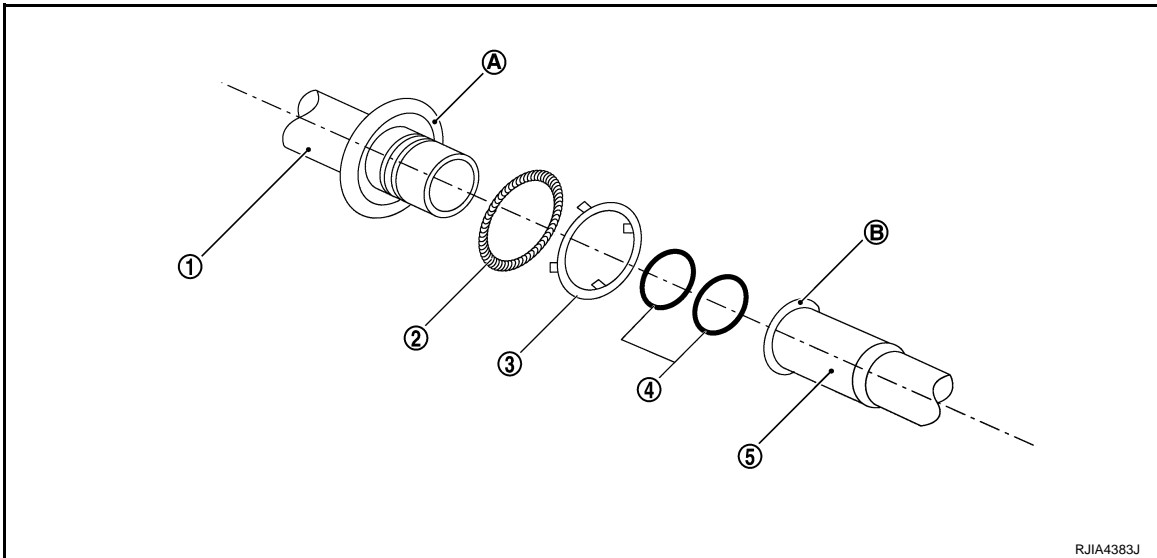

FUNCTIONS OF COMPONENT PARTS

1	Pipe (Male-side)	<ul style="list-style-type: none"> • Retains O-rings. • Retains garter spring in cage (A).
2	Garter spring	Anchors female-side piping.
3	Indicator ring	When connection is made properly, this is ejected from male-side piping. (This part is no longer necessary after connection.)
4	O-ring	Seals connection point. (Not reusable)
5	Pipe (Female-side)	<ul style="list-style-type: none"> • Seals connection by compressing O-rings. • Anchors piping connection using flare (B) and garter spring.

NOTE:

A

B

C

D

E

F

G

H

I

ATC

K

L

M

N

O

P

PRECAUTIONS

< SERVICE INFORMATION >

- Garter spring cannot be removed from cage of male-side piping.
- Indicator ring remains near piping connection point, however, this is not a malfunction. (This is to check piping connection during factory assembly.)

REMOVAL

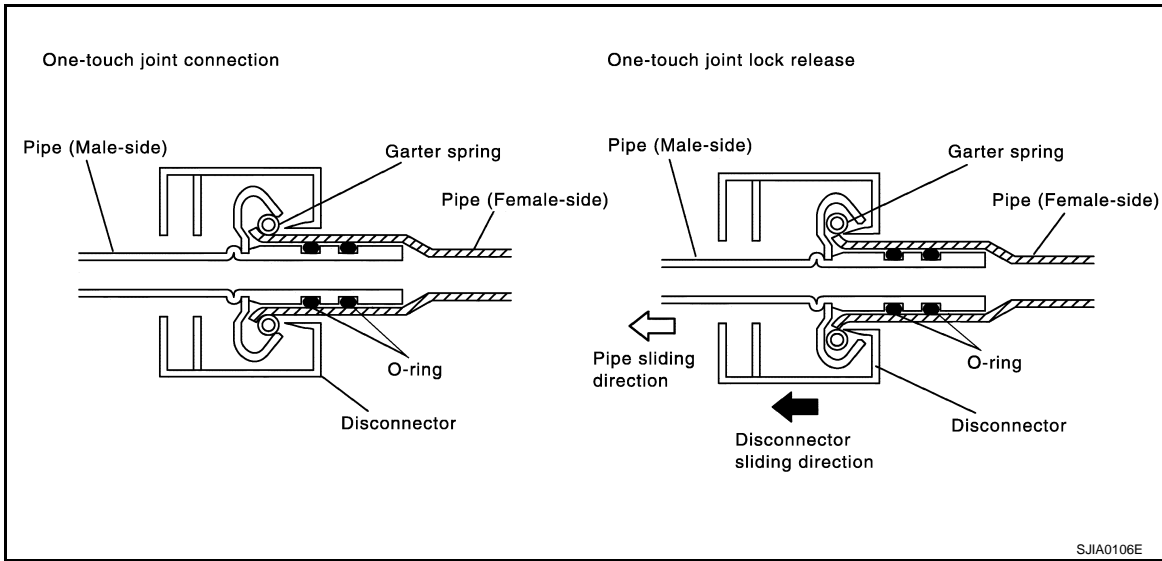

1. Clean piping connection point, and set a disconnecter.
2. Slide disconnecter in axial direction of piping, and stretch garter spring with tapered point of disconnecter.
3. Slide disconnecter farther so that inside diameter of garter spring becomes larger than outside diameter of female-side piping flare. Then male-side piping can be disconnected.

INSTALLATION

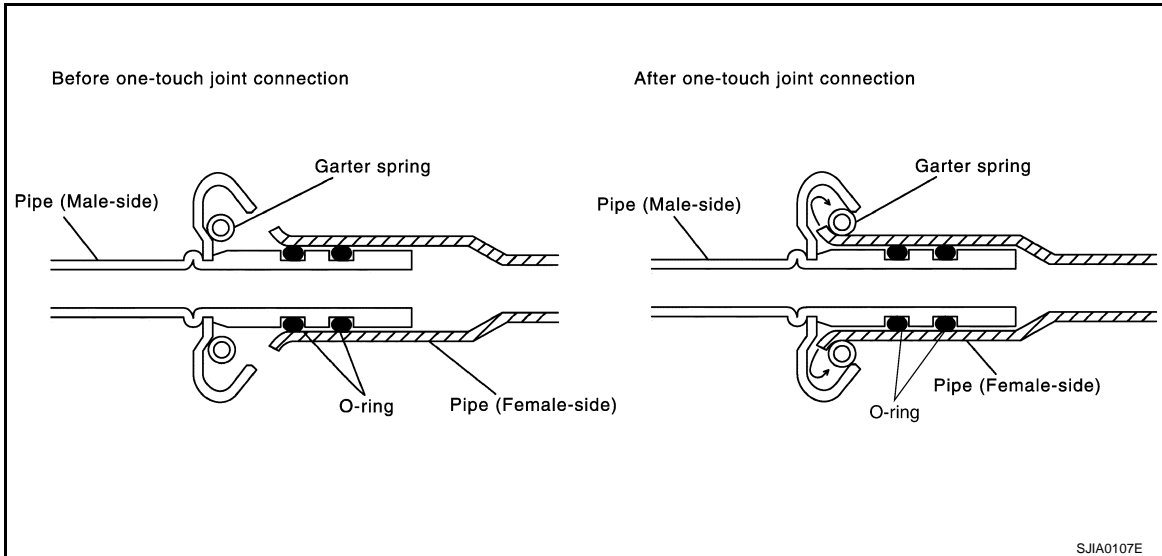

1. Clean piping connection points, and insert male-side piping into female-side piping.
2. Push inserted male-side piping harder so that female-side piping flare stretches garter spring.
3. If inside diameter of garter spring becomes larger than outside diameter of female-side piping flare, garter spring seats on flare. Then, it fits in between male-side piping cage and female-side piping flare to anchor piping connection point.

NOTE:

When garter spring seats on flare, and fits in between male-side piping cage and female-side piping flare, it clicks.

CAUTION:

- Female-side piping connection is thin and easy to deform. Slowly insert the male-side piping straight in axial direction.
- Insert piping securely until a click is heard.
- After piping connection is completed, pull male-side piping by hand to make sure that connection does not come loose.

NOTE:

One-touch joint connection is used in points below.

PRECAUTIONS

< SERVICE INFORMATION >

- Low-pressure pipe 1 to low-pressure pipe 2 (O-ring size: 16)
- High-pressure pipe 1 to high-pressure pipe 2 (O-ring size: 8)
- High-pressure pipe 2 to high-pressure pipe 3 (O-ring size: 8)
- Low-pressure flexible hose to low-pressure pipe 1 (O-ring size: 16)
- Condenser to high-pressure flexible hose (O-ring size: 12)
- Condenser to high-pressure pipe 1 (O-ring size: 8)

FEATURES OF NEW TYPE REFRIGERANT CONNECTION

- The O-ring has been relocated. It has also been provided with a groove for proper installation. This eliminates the possibility of the O-ring being caught in, or damaged by, the mating part. The sealing direction of the O-ring is now set vertically in relation to the contacting surface of the mating part to improve sealing characteristics.
- The reaction force of the O-ring will not occur in the direction that causes the joint to pull out, thereby facilitating piping connections.

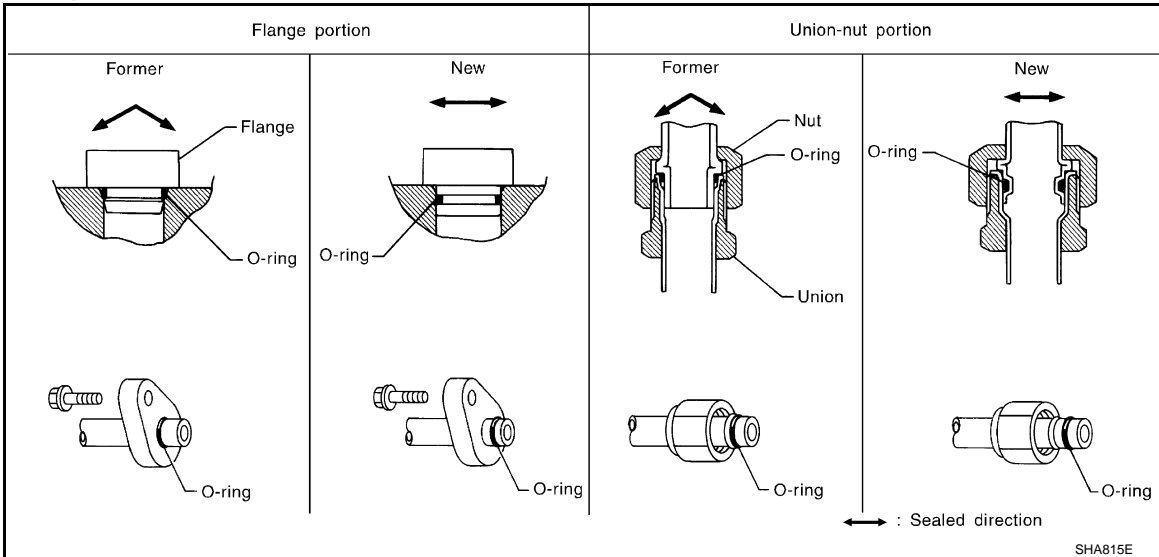

O-RING AND REFRIGERANT CONNECTION

VQ35DE

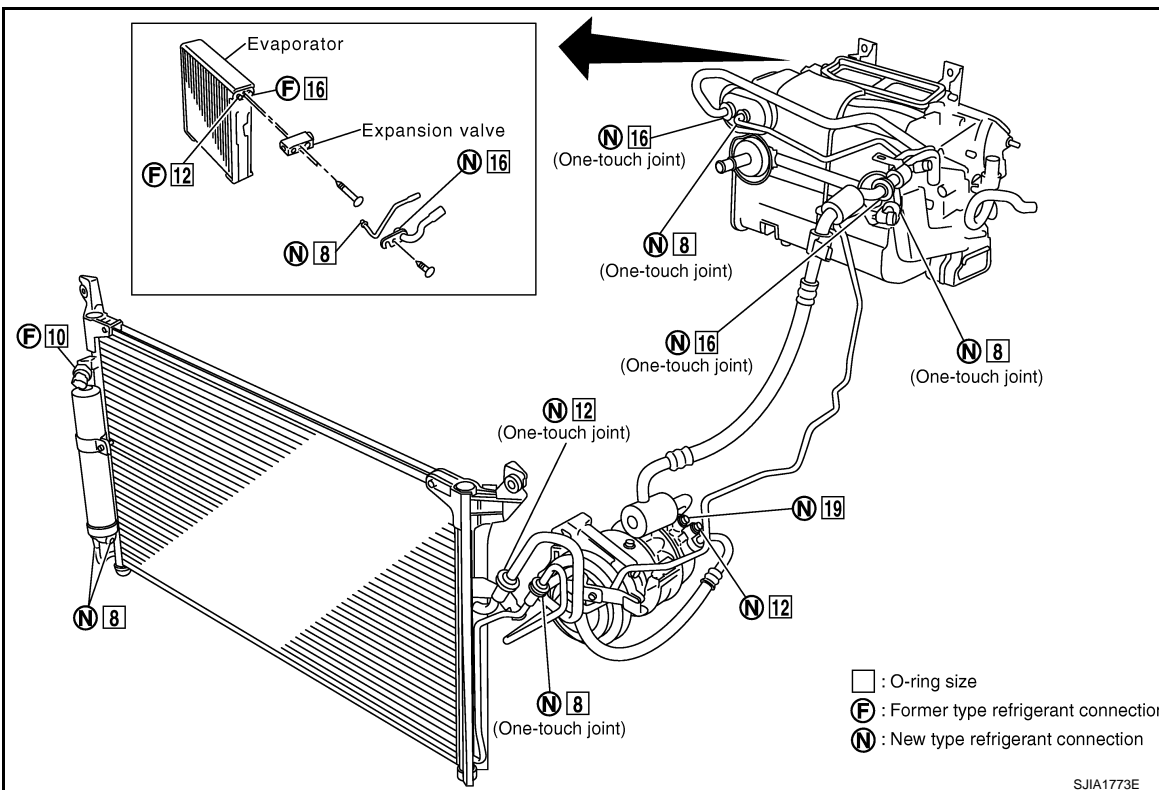

PRECAUTIONS

< SERVICE INFORMATION >

VK45DE

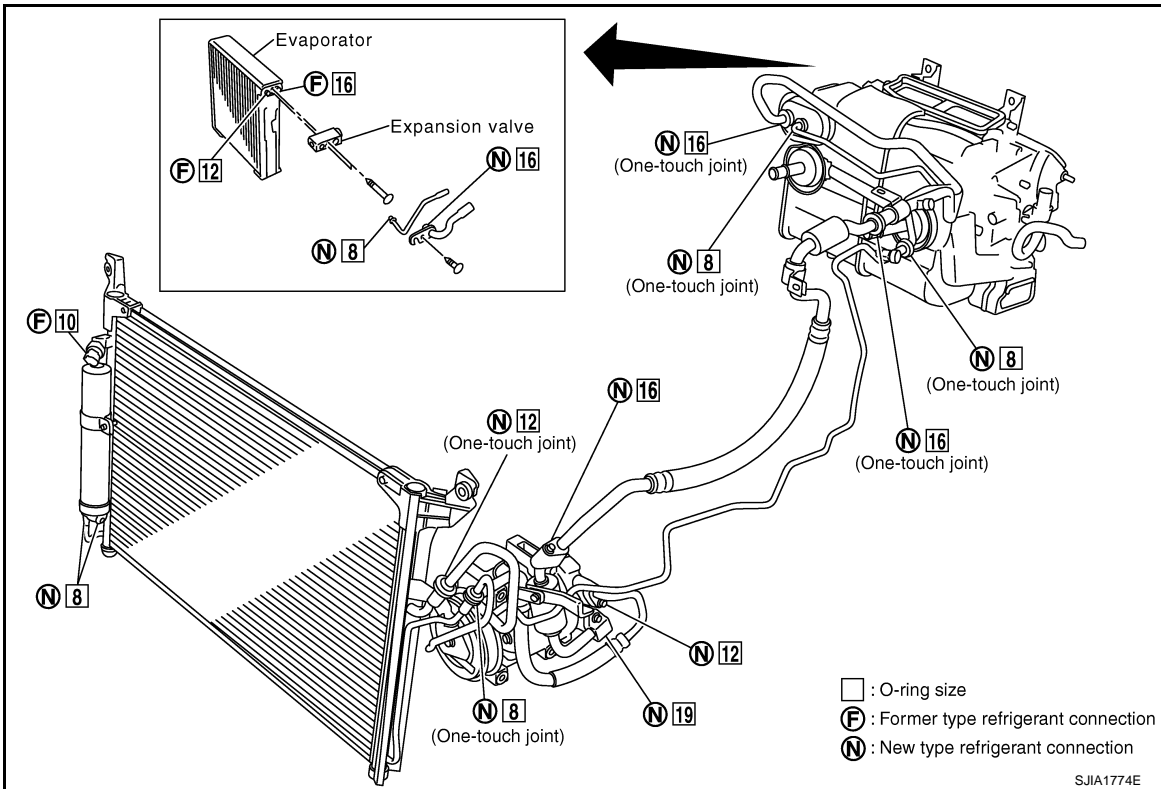

CAUTION:

The new and former refrigerant connections use different O-ring configurations. Never confuse O-rings since they are not interchangeable. If a wrong O-ring is installed, refrigerant may leak at the connection.

O-Ring Part Numbers and Specifications

Connection type	Piping connection point		Part number	QTY	O-ring size	
New	Low-pressure pipe 1 to low-pressure pipe 2 (One-touch joint)		92473 N8221	2	16	
	Low-pressure pipe 2 to expansion valve		92473 N8210	1	16	
	High-pressure pipe 1 to high-pressure pipe 2 (One-touch joint)		92471 N8221	2	8	
	High-pressure pipe 3 to expansion valve		92471 N8210	1	8	
	High-pressure pipe 2 to high-pressure pipe 3 (One-touch joint)		92471 N8221	2	8	
	Condenser to high-pressure flexible hose (One-touch joint)		92472 N8221	2	12	
	Condenser to high-pressure pipe 1 (One-touch joint)		92471 N8221	2	8	
	Low-pressure flexible hose to low-pressure pipe 1 (One-touch joint)		92473 N8221	2	16	
	Low-pressure pipe to low-pressure flexible hose (VK45DE)		92474 N8210	1	19	
	Compressor to low-pressure flexible hose (VQ35DE)		92474 N8210	1	19	
	Compressor to low-pressure pipe (VK45DE)		92474 N8210	1	19	
	Compressor to high-pressure flexible hose		92472 N8210	1	12	
	Former	Liquid tank to condenser pipe	Inlet	92471 N8210	1	8
Outlet			1			
Refrigerant pressure sensor to condenser				J2476 89956	1	10
		Expansion valve to evaporator	Inlet	92475 71L00	1	12
			Outlet	92475 72L00	1	16

WARNING:

Make sure all refrigerant is discharged into the recycling equipment and the pressure in the system is less than atmospheric pressure. Then gradually loosen the discharge side hose fitting and remove it.

PRECAUTIONS

< SERVICE INFORMATION >

CAUTION:

When replacing or cleaning refrigerant cycle components, observe the following.

- When the compressor is removed, store it in the same way as it is when mounted on the car. Failure to do so will cause lubricant to enter the low-pressure chamber.
- When connecting tubes, always use a torque wrench and a back-up wrench.
- After disconnecting tubes, immediately plug all openings to prevent entry of dust and moisture.
- When installing an air conditioner in the vehicle, connect the pipes at the final stage of the operation. Never remove the seal caps of pipes and other components until just before required for connection.
- Allow components stored in cool areas to warm to working area temperature before removing seal caps. This prevents condensation from forming inside A/C components.
- Thoroughly remove moisture from the refrigeration system before charging the refrigerant.
- Always replace used O-rings.
- When connecting tubes, apply lubricant to circle of the O-rings shown in illustration. Be careful not to apply lubricant to threaded portion.

Name : Nissan A/C System Oil Type S

- O-ring must be closely attached to the groove of tube.
- When replacing the O-ring, be careful not to damage O-ring and tube.
- Connect tube until a click can be heard, then tighten the nut or bolt by hand. Make sure that the O-ring is installed to tube correctly.
- After connecting line, perform leak test and make sure that there is no leakage from connections. When the refrigerant leaking point is found, disconnect that line and replace the O-ring. Then tighten connections of seal seat to the specified torque.

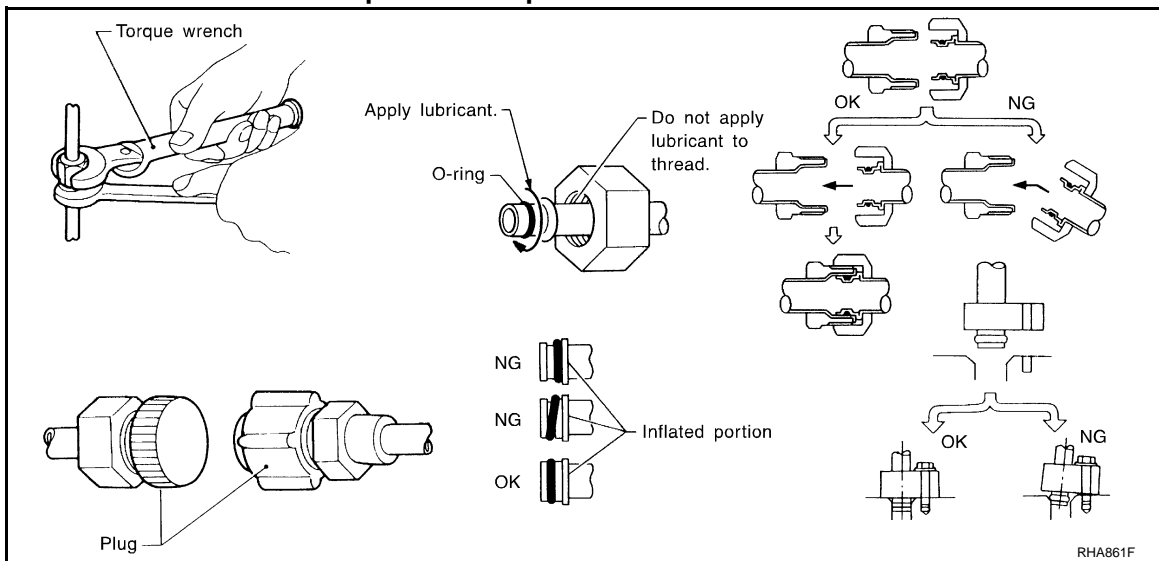

Precaution for Service of Compressor

INFOID:000000001328156

- Plug all openings to prevent moisture and foreign matter from entering.
- When the compressor is removed, store it in the same way as it is when mounted on the car.
- When replacing or repairing compressor, follow "Maintenance of Lubricant Quantity in Compressor" exactly. Refer to [ATC-22. "Maintenance of Lubricant Quantity in Compressor"](#).
- Keep friction surfaces between clutch and pulley clean. If the surface is contaminated with lubricant, wipe it off by using a clean waste cloth moistened with thinner.
- After compressor service operation, turn the compressor shaft by hand more than five turns in both directions. This will equally distribute lubricant inside the compressor. After the compressor is installed, let the engine idle and operate the compressor for one hour.
- After replacing the compressor magnet clutch, apply voltage to the new one and check for normal operation.

Precaution for Service Equipment

INFOID:000000001328157

RECOVERY/RECYCLING EQUIPMENT

PRECAUTIONS

< SERVICE INFORMATION >

Be certain to follow the manufacturer's instructions for machine operation and machine maintenance. Never introduce any refrigerant other than that specified into the machine.

ELECTRICAL LEAK DETECTOR

Be certain to follow the manufacturer's instructions for tester operation and tester maintenance.

VACUUM PUMP

The lubricant contained inside the vacuum pump is not compatible with the specified lubricant for HFC-134a (R-134a) A/C systems. The vent side of the vacuum pump is exposed to atmospheric pressure. So the vacuum pump lubricant may migrate out of the pump into the service hose. This is possible when the pump is switched off after evacuation (vacuuming) and hose is connected to it.

To prevent this migration, use a manual valve placed near the hose-to-pump connection, as follows.

- Usually vacuum pumps have a manual isolator valve as part of the pump. Close this valve to isolate the service hose from the pump.
- For pumps without an isolator, use a hose equipped with a manual shut-off valve near the pump end. Close the valve to isolate the hose from the pump.
- If the hose has an automatic shut-off valve, disconnect the hose from the pump. As long as the hose is connected, the valve is open and lubricating oil may migrate.

Some one-way valves open when vacuum is applied and close under no vacuum condition. Such valves may restrict the pump's ability to pull a deep vacuum and are not recommended.

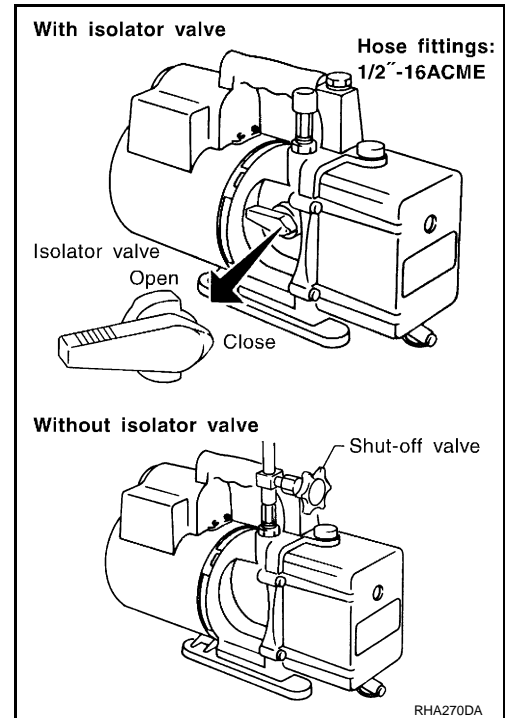

MANIFOLD GAUGE SET

Be certain that the gauge face indicates HFC-134a or R-134a. Be sure the gauge set has 1/2\"-16 ACME threaded connections for service hoses. Confirm the set has been used only with refrigerant HFC-134a (R-134a) and specified lubricants.

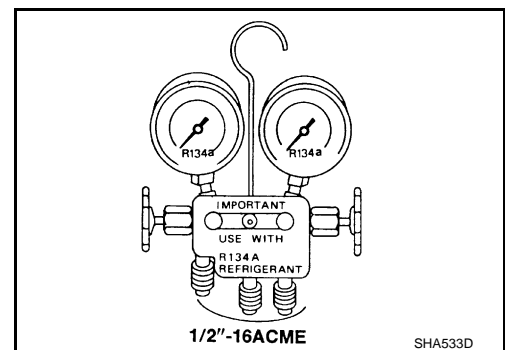

SERVICE HOSES

Be certain that the service hoses display the markings described (colored hose with black stripe). All hoses must include positive shut-off devices (either manual or automatic) near the end of the hoses opposite to the manifold gauge.

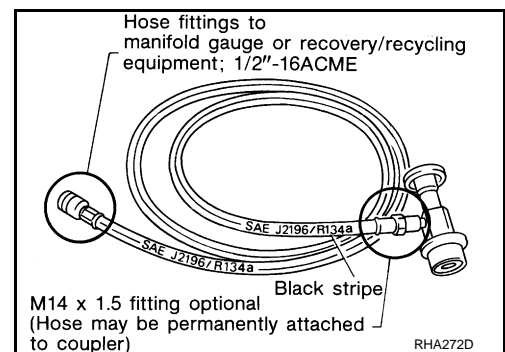

SERVICE COUPLERS

PRECAUTIONS

< SERVICE INFORMATION >

Never attempt to connect HFC-134a (R-134a) service couplers to a CFC-12 (R-12) A/C system. The HFC-134a (R-134a) couplers will not properly connect to the CFC-12 (R-12) system. However, if an improper connection is attempted, discharging and contamination may occur.

Shut-off valve rotation	A/C service valve
Clockwise	Open
Counterclockwise	Close

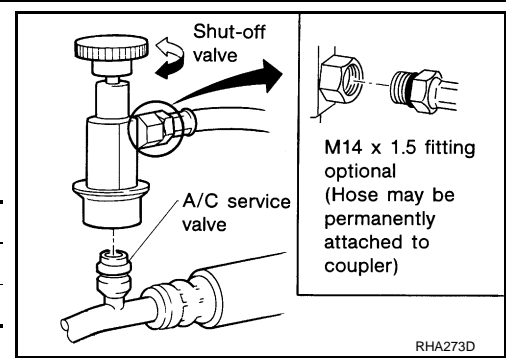

REFRIGERANT WEIGHT SCALE

Verify that no refrigerant other than HFC-134a (R-134a) and specified lubricants have been used with the scale. If the scale controls refrigerant flow electronically, the hose fitting must be 1/2" -16 ACME.

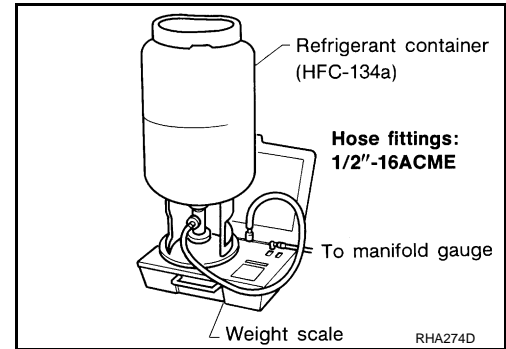

CHARGING CYLINDER

Using a charging cylinder is not recommended. Refrigerant may be vented into air from cylinder's top valve when filling the cylinder with refrigerant. Also, the accuracy of the cylinder is generally less than that of an electrical scale or of quality recycle/recharge equipment.

Precaution for Leak Detection Dye

INFOID:000000001328158

- The A/C system contains a fluorescent leak detection dye used for locating refrigerant leaks. An ultraviolet (UV) lamp is required to illuminate the dye when inspecting for leaks.
- Always wear fluorescence enhancing UV safety goggles to protect your eyes and enhance the visibility of the fluorescent dye.
- The fluorescent dye leak detector is not a replacement for an electrical leak detector (SST: J-41995). The fluorescent dye leak detector should be used in conjunction with an electrical leak detector (SST: J-41995) to pin-point refrigerant leaks.
- For the purpose of safety and customer's satisfaction, read and follow all manufacturer's operating instructions and precautions prior to performing the work.
- A compressor shaft seal should not necessarily be repaired because of dye seepage. The compressor shaft seal should only be repaired after confirming the leak with an electrical leak detector (SST: J-41995).
- Always remove any remaining dye from the leak area after repairs are completed to avoid a misdiagnosis during a future service.
- Never allow dye to come into contact with painted body panels or interior components. If dye is spilled, clean immediately with the approved dye cleaner. Fluorescent dye left on a surface for an extended period of time cannot be removed.
- Never spray the fluorescent dye cleaning agent on hot surfaces (engine exhaust manifold, etc.).
- Never use more than one refrigerant dye bottle (1/4 ounce /7.4 cc) per A/C system.
- Leak detection dyes for HFC-134a (R-134a) and CFC-12 (R-12) A/C systems are different. Never use HFC-134a (R-134a) leak detection dye in CFC-12 (R-12) A/C system, or CFC-12 (R-12) leak detection dye in HFC-134a (R-134a) A/C system, or A/C system damage may result.
- The fluorescent properties of the dye will remain for three years or a little over unless a compressor malfunction occurs.

IDENTIFICATION

NOTE:

Vehicles with factory installed fluorescent dye have a green label.
Vehicles without factory installed fluorescent dye have a blue label.

IDENTIFICATION LABEL FOR VEHICLE

A
B
C
D
E
F
G
H
I
K
L
M
N
O
P

ATC

PRECAUTIONS

< SERVICE INFORMATION >

Vehicles with factory installed fluorescent dye have the identification label on the front side of hood.

PREPARATION

< SERVICE INFORMATION >

PREPARATION

Special Service Tool

INFOID:000000001328159

The actual shapes of Kent-Moore tools may differ from those of special service tools illustrated here.

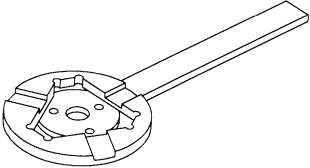
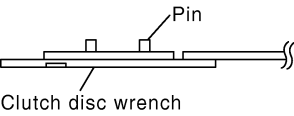
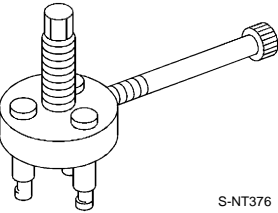
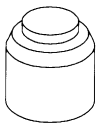
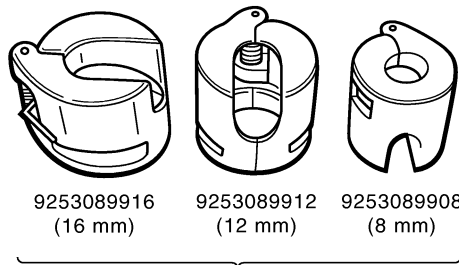
Tool number (Kent-Moore No.) Tool name	Description
<p>KV99106100 (J-41260) Clutch disc wrench</p> <div style="text-align: center;">  <p>S-NT232</p> </div> <div style="text-align: center;">  <p>Clutch disc wrench</p> <p>S-JIA1168E</p> </div>	<p>Removing shaft nut and clutch disc</p>
<p>KV99232340 (J-38874) Clutch disc puller</p> <div style="text-align: center;">  <p>S-NT376</p> </div>	<p>Removing clutch disc</p>
<p>KV99106200 (J-41261) Pulley installer</p> <div style="text-align: center;">  <p>S-NT235</p> </div>	<p>Installing pulley</p>
<p>9253089908 (for high-pressure pipe 1) (-) 9253089912 (for high-pressure flexible hose) (-) 9253089916 (for low-pressure pipe 1 and low-pressure flexible hose) (-) Disconnecter tool set (J-45815)</p> <div style="text-align: center;">  <p>9253089916 (16 mm) 9253089912 (12 mm) 9253089908 (8 mm)</p> <p>Disconnecter tool set : J-45815</p> <p>S-JIA1274E</p> </div>	<p>Disconnect one-touch joint connection</p>

HFC-134a (R-134a) Service Tool and Equipment

INFOID:000000001328160

Never mix HFC-134a (R-134a) refrigerant and/or its specified lubricant with CFC-12 (R-12) refrigerant and/or its lubricant.



Separate and non-interchangeable service equipment must be used for handling each type of refrigerant/lubricant.

PREPARATION

< SERVICE INFORMATION >



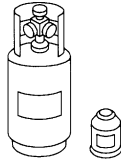

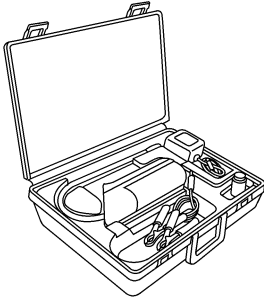
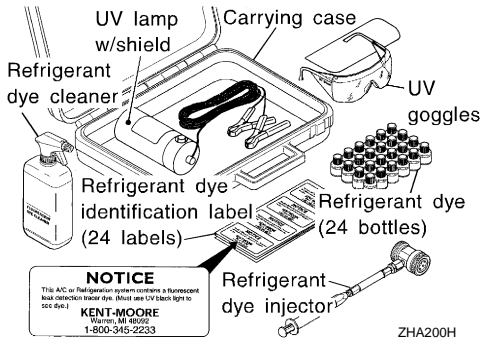
Refrigerant container fittings, service hose fittings and service equipment fittings (equipment which handles refrigerant and/or lubricant) are different between CFC-12 (R-12) and HFC-134a (R-134a). This is to avoid mixed use of the refrigerants/lubricant.

Never use adapters that convert one size fitting to another: refrigerant/lubricant contamination occurs and compressor malfunction may result.

Tool number (Kent-Moore No.) Tool name	Description
<p>HFC-134a (R-134a) refrigerant</p> <div style="text-align: center;">  <p>S-NT196</p> </div>	<p>Container color: Light blue Container marking: HFC-134a (R-134a) Fitting size: Thread size</p> <ul style="list-style-type: none"> • Large container 1/2" -16 ACME
<p>Nissan A/C System Oil Type S (DH-PS)</p> <div style="text-align: center;">  <p>S-NT197</p> </div>	<p>Type: Polyalkylene glycol oil (PAG), type S (DH-PS) Application: HFC-134a (R-134a) wobble (swash) plate compressors (Nissan only) Capacity: 40 mℓ (1.4 US fl oz., 1.4 Imp fl oz.)</p>
<p>(ACR2005-NI) ACR5 A/C Service Center</p> <div style="text-align: center;">  <p>WJIA0293E</p> </div>	<p>Function: Refrigerant recovery, recycling and recharging</p>
<p>(J-41995) Electrical A/C leak detector</p> <div style="text-align: center;">  <p>AHA281A</p> </div>	<p>Power supply: DC 12 V (Battery terminal)</p>
<p>(J-43926) Refrigerant dye leak detection kit Kit includes: (J-42220) UV lamp and UV safety goggles (J-41459) HFC-134a (R-134a) dye injector Use with J-41447, 1/4 ounce bottle (J-41447) HFC-134a (R-134a) fluorescent leak detection dye (Box of 24, 1/4 ounce bottles) (J-43872) Refrigerant dye cleaner</p>	<div style="text-align: center;">  <p>ZHA200H</p> </div> <p>Power supply: DC 12 V (Battery terminal)</p>

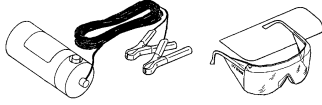
PREPARATION

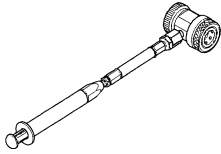
< SERVICE INFORMATION >

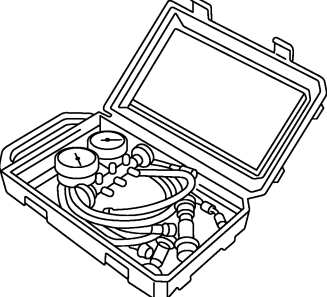
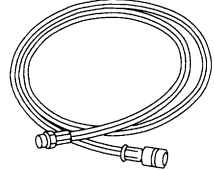
Tool number (Kent-Moore No.) Tool name	Description	A
(J-42220) UV lamp and UV safety goggles  SHA438F	Power supply: DC 12 V (Battery terminal) For checking refrigerant leak when fluorescent dye is installed in A/C system Includes: UV lamp and UV safety goggles	B C
(J-41447) HFC-134a (R-134a) fluorescent leak detection dye (Box of 24, 1/4 ounce bottles)  Refrigerant dye (24 bottles) SHA439F	Application: For HFC-134a (R-134a) PAG oil Container: 1/4 ounce (7.4 cc) bottle (Includes self-adhesive dye identification labels for affixing to vehicle after charging system with dye.)	D E
(J-41459) HFC-134a (R-134a) dye injector Use with J-41447, 1/4 ounce bottle  SHA440F	For injecting 1/4 ounce of fluorescent leak detection dye into A/C system	F G H
(J-43872) Refrigerant dye cleaner  SHA441F	For cleaning dye spills	I ATC
(J-39183) Manifold gauge set (with hoses and couplers)  RJIA0196E	Identification: <ul style="list-style-type: none"> • The gauge face indicates HFC-134a (R-134a). Fitting size: Thread size <ul style="list-style-type: none"> • 1/2" -16 ACME 	K L M
Service hoses <ul style="list-style-type: none"> • High-pressure side hose (J-39501-72) • Low-pressure side hose (J-39502-72) • Utility hose (J-39476-72)  S-NT201	Hose color: <ul style="list-style-type: none"> • Low hose: Blue with black stripe • High hose: Red with black stripe • Utility hose: Yellow with black stripe or green with black stripe Hose fitting to gauge: <ul style="list-style-type: none"> • 1/2" -16 ACME 	N O P

PREPARATION

< SERVICE INFORMATION >

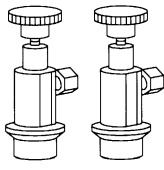
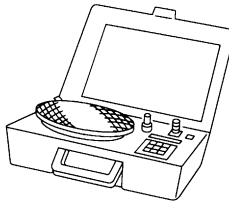
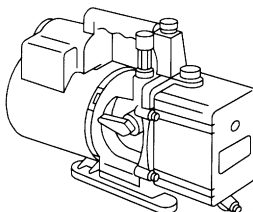
Tool number (Kent-Moore No.) Tool name	Description
<p>Service couplers</p> <ul style="list-style-type: none"> • High-pressure side coupler (J-39500-20) • Low-pressure side coupler (J-39500-24)  <p style="text-align: right; font-size: small;">S-NT202</p>	<p>Hose fitting to service hose: M14 x 1.5 fitting is optional or permanently attached.</p>
<p>(J-39650) Refrigerant weight scale</p>  <p style="text-align: right; font-size: small;">S-NT200</p>	<p>For measuring of refrigerant Fitting size: Thread size 1/2"-16 ACME</p>
<p>(J-39649) Vacuum pump (Including the isolator valve)</p>  <p style="text-align: right; font-size: small;">S-NT203</p>	<p>Capacity:</p> <ul style="list-style-type: none"> • Air displacement: 4 CFM • Micron rating: 20 microns • Oil capacity: 482 g (17 oz.) <p>Fitting size: Thread size</p> <ul style="list-style-type: none"> • 1/2"-16 ACME

Commercial Service Tool

INFOID:000000001328161

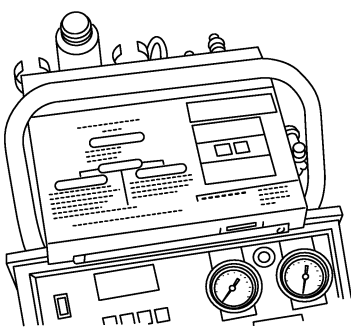
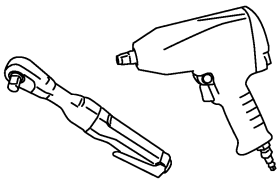
Tool name	Description
<p>Refrigerant identifier equipment</p>  <p style="text-align: right; font-size: x-small;">RJIA0197E</p>	<p>Checking for refrigerant purity and system contamination</p>
<p>Power tool</p>  <p style="text-align: right; font-size: x-small;">PBIC0190E</p>	<p>For loosening bolts and nuts</p>

REFRIGERATION SYSTEM

< SERVICE INFORMATION >

REFRIGERATION SYSTEM

Refrigerant Cycle

INFOID:000000001328162

REFRIGERANT FLOW

The refrigerant flows from the compressor, through the condenser with liquid tank, through the evaporator, and back to the compressor. The refrigerant evaporation in the evaporator is controlled by an externally equalized expansion valve, located inside the evaporator case.

FREEZE PROTECTION

To prevent evaporator frozen up, the evaporator air temperature is monitored, and the voltage signal to the unified meter and A/C auto amp. will make the A/C relay go OFF and stop the compressor.

Refrigerant System Protection

INFOID:000000001328163

REFRIGERANT PRESSURE SENSOR

The refrigerant system is protected against excessively high- or low-pressure by the refrigerant pressure sensor, located on the condenser. If the system pressure rises above, or falls below the specifications, the refrigerant pressure sensor detects the pressure inside the refrigerant line and sends the voltage signal to the ECM. ECM makes the A/C relay go OFF and stops the compressor when pressure on the high-pressure side detected by refrigerant pressure sensor is over about 2,746 kPa (28 kg/cm², 398 psi), or below about 134 kPa (1.4 kg/cm², 20 psi).

PRESSURE RELIEF VALVE

The refrigerant system is also protected by a pressure relief valve, located in the rear head of the compressor. When the pressure of refrigerant in the system increases to an unusual level [more than 3,727 kPa (38 kg/cm², 540 psi)], the release port on the pressure relief valve automatically opens and releases refrigerant into the atmosphere.

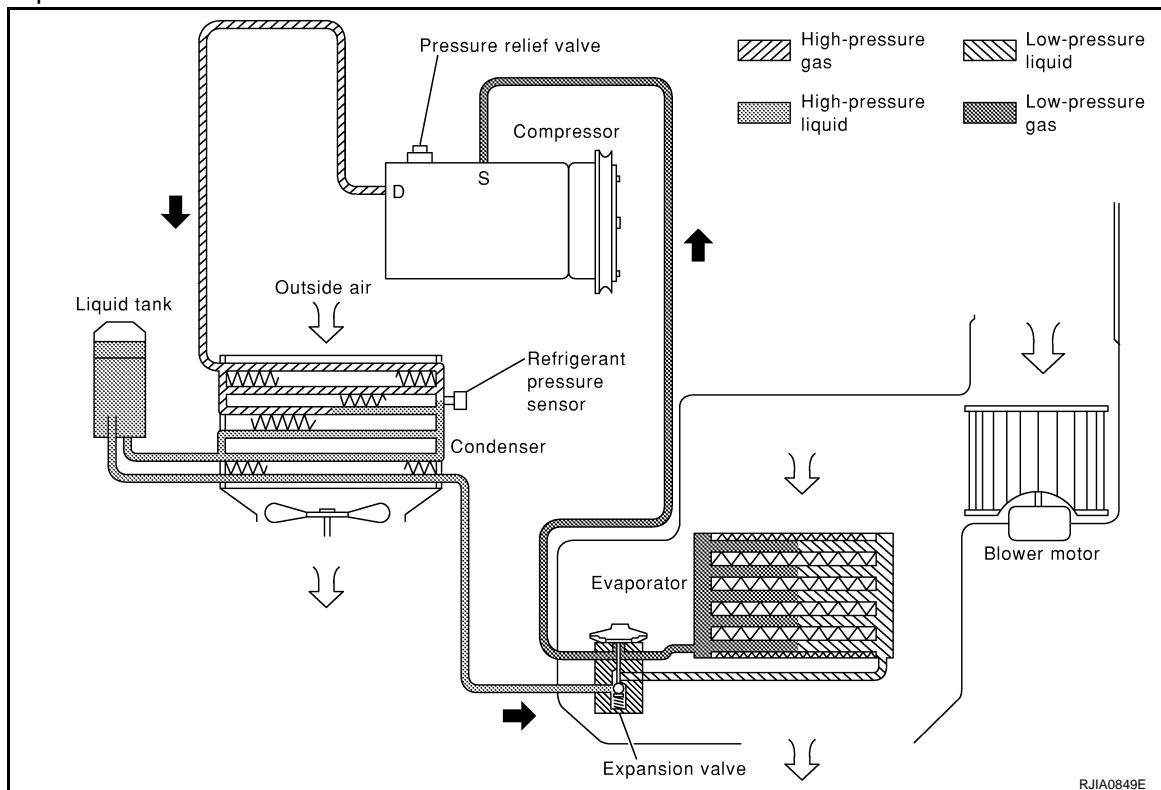

V-6 Variable Displacement Compressor

INFOID:000000001328164

GENERAL INFORMATION

1. The V-6 variable compressor differs from previous units. The outlet air temperatures of the V-6 variable compressor do not drop too far below 5°C (41°F) when:

REFRIGERATION SYSTEM

< SERVICE INFORMATION >

Evaporator intake air temperature is less than 20°C (68°F).

Engine is running at speeds less than 1,500 rpm.

This is because the V-6 compressor provides a means of “capacity” control.

2. The V-6 variable compressor provides refrigerant control under varying conditions. During cold winters, it may not produce high refrigerant pressure discharge (compared to previous units) when used with air conditioning systems.
3. A “clanking” sound may occasionally be heard during refrigerant charge. The sound indicates that the tilt angle of the wobble (swash) plate has changed and is not a malfunction.
4. For air conditioning systems with the V-6 compressor, the clutch remains engaged unless: the system main switch, fan switch or ignition switch is turned OFF. When ambient (outside) temperatures are low or when the amount of refrigerant is insufficient, the clutch is disengaged to protect the compressor.

DESCRIPTION

General

The variable compressor is a swash plate type that changes piston stroke in response to the required cooling capacity.

The tilt of the wobble (swash) plate allows the piston’s stroke to change so that refrigerant discharge continuously change from 14.5 to 184 cm³ (0.885 to 11.228 cu in).

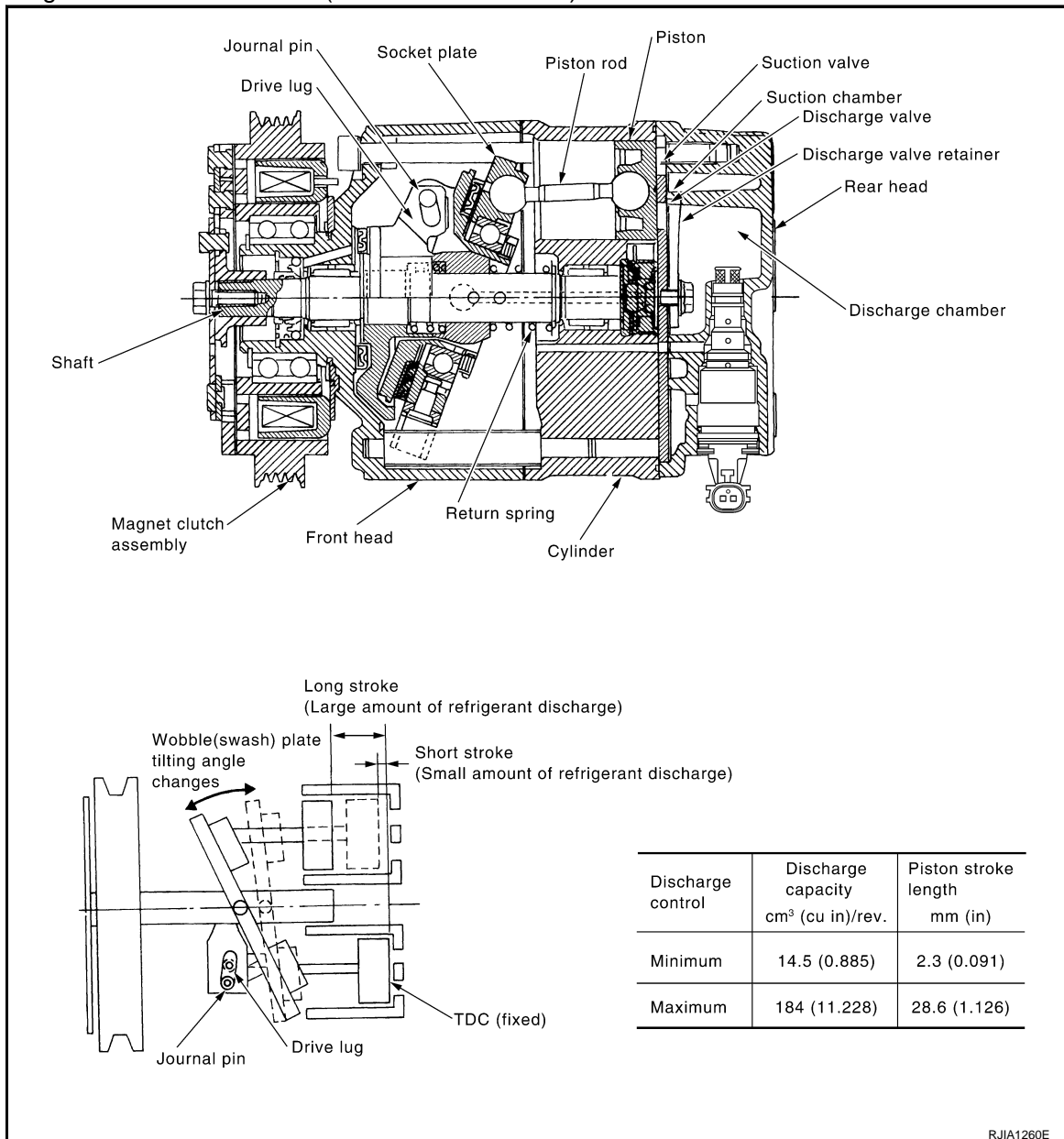

RJA1260E

REFRIGERATION SYSTEM

< SERVICE INFORMATION >

Operation

1. Control Valve

- By changing high-pressure valve lift amount, built-in electronic control valve executes the following:
 - Controls high-pressure valve discharge amount.
 - Changes crankcase pressure in compressor.
 - Changes angle of wobble (swash) plate.
- Amount of high-pressure valve lift is determined by factors below.
 - Low-pressure applied to diaphragm
 - Spring load of set spring
 - Balance of magnetic force generated in magnet coil
- Electronic control valve (ECV) magnet coil receives electric signal (duty control) from unified meter and A/C amp. Then, magnetic force generated by electric current is changed to control high-pressure valve lift amount.

2. Maximum Cooling

High-pressure valve is closed by magnetic force generated by electric signal sent from unified meter and A/C amp. At this time, cylinder moves full stroke due to pressure balance between inside crankcase (P_c) and suction line (P_s).

Under this condition, the wobble (swash) plate is set to the maximum stroke position.

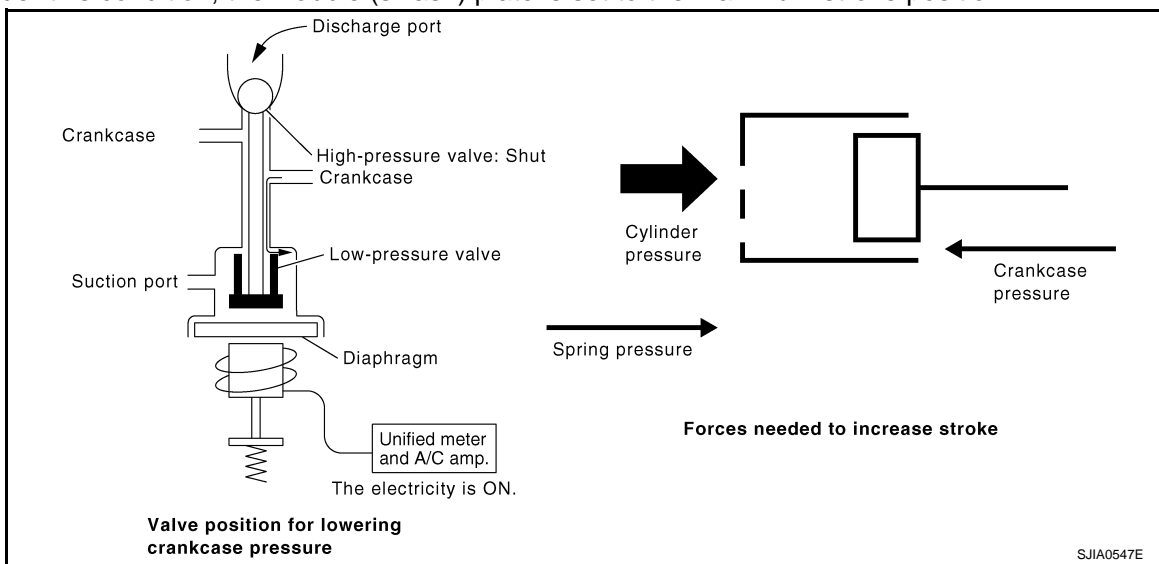

3. Capacity Control

When no electric signal is sent from unified meter and A/C amp. (current: OFF), high-pressure valve is opened by spring force.

Since suction pressure is low, it makes the suction port close and the discharge port open. Thus, crankcase pressure becomes high as high-pressure enters the crankcase.

- The force acts around the journal pin near the wobble (swash) plate, and is generated by the pressure difference before and behind the piston.
- The drive lug and journal pin are located where the piston generates the highest pressure. Piston pressure is between suction pressure P_s and discharge pressure P_d , which is close to suction pressure P_s . If crankcase pressure P_c rises due to capacity control, the force around the journal pin makes the wobble (swash) plate angle decrease and also the piston stroke decrease. In other words, crankcase pressure

REFRIGERATION SYSTEM

< SERVICE INFORMATION >

increase triggers pressure difference between the piston and the crankcase. The pressure difference changes the angle of the wobble (swash) plate.

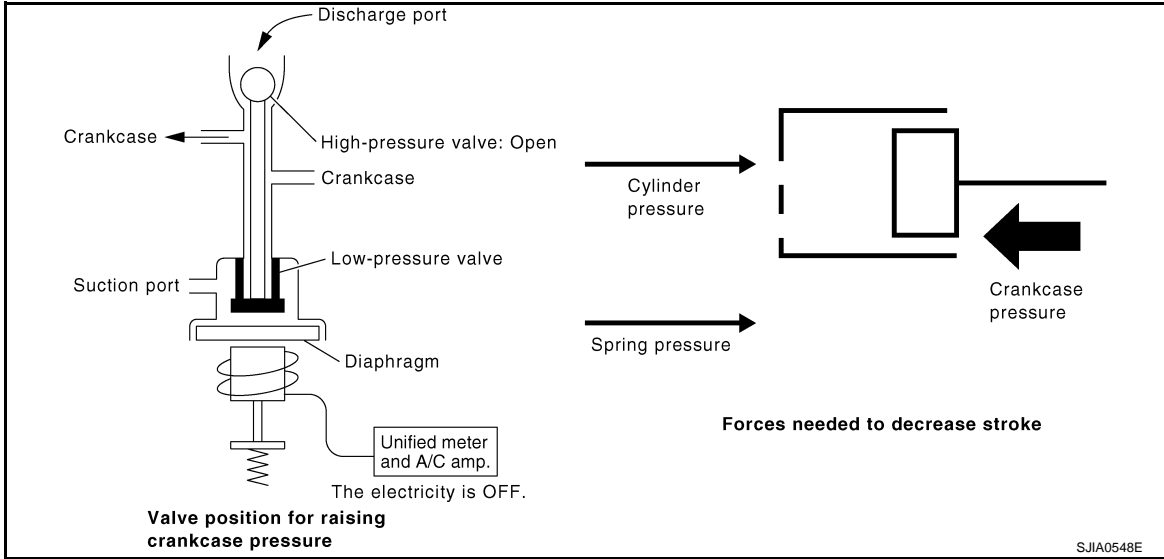

REFRIGERATION SYSTEM

< SERVICE INFORMATION >

Component Part Location

INFOID:000000001328165

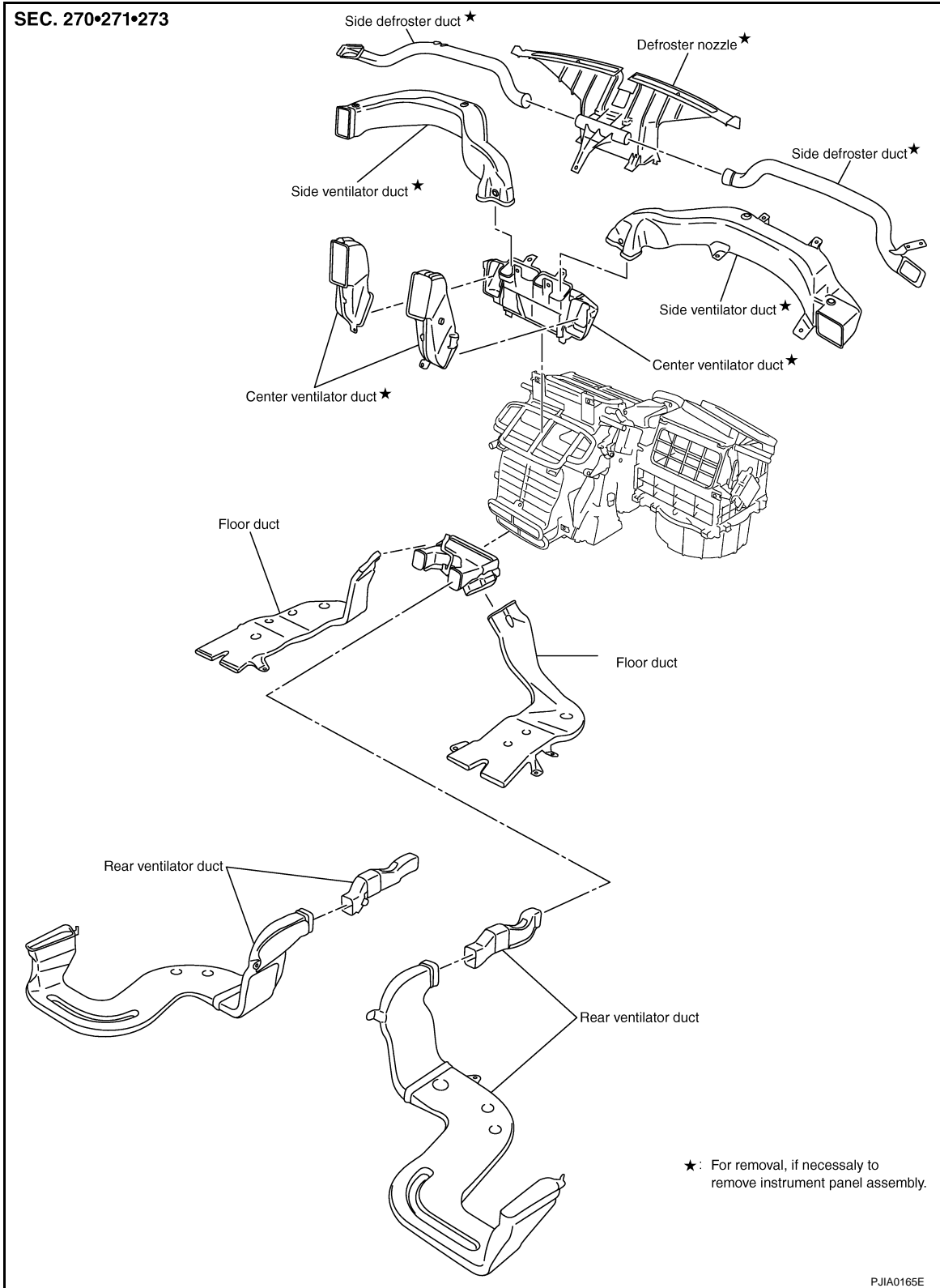

A
B
C
D
E
F
G
H
I
ATC
K
L
M
N
O
P

LUBRICANT

< SERVICE INFORMATION >

LUBRICANT

Maintenance of Lubricant Quantity in Compressor

INFOID:000000001328166

The lubricant in the compressor circulates through the system with the refrigerant. Add lubricant to compressor when replacing any component or after a large refrigerant leakage occurred. It is important to maintain the specified amount.

If lubricant quantity is not maintained properly, the following malfunctions may result:

- Lack of lubricant: May lead to a seized compressor.
- Excessive lubricant: Inadequate cooling (thermal exchange interference)

LUBRICANT

Name : NISSAN A/C System Oil Type S

LUBRICANT RETURN OPERATION

Adjust the lubricant quantity according to the test group shown below.

1. CHECK LUBRICANT RETURN OPERATION

Can lubricant return operation be performed?

- A/C system works properly.
- There is no evidence of a large amount of lubricant leakage.

CAUTION:

If excessive lubricant leakage is noted, never perform the lubricant return operation.

OK or NG

- OK >> GO TO 2.
- NG >> GO TO 3.

2. PERFORM LUBRICANT RETURN OPERATION, PROCEEDING AS FOLLOWS

1. Start the engine, and set to the following conditions:
 - Engine speed: Idling to 1,200 rpm
 - A/C switch: ON
 - Blower speed: Max. position
 - Temp. control: Optional [Set so that intake air temperature is 25 to 30°C (77 to 86°F).]
 - Intake position: Recirculation (REC)
2. Perform lubricant return operation for about 10 minutes.
3. Stop the engine.

>> GO TO 3.

3. CHECK REPLACEMENT PART

Should the compressor be replaced?

- YES >> Go to "LUBRICANT ADJUSTING PROCEDURE FOR COMPRESSOR REPLACEMENT".
- NO >> Go to "LUBRICANT ADJUSTING PROCEDURE FOR COMPONENTS REPLACEMENT EXCEPT COMPRESSOR".

LUBRICANT ADJUSTING PROCEDURE FOR COMPONENTS REPLACEMENT EXCEPT COMPRESSOR

After replacing any of the following major components, add the correct amount of lubricant to the system.
Amount of lubricant to be added:

Part replaced	Lubricant to be added to system		Remarks
	Amount of lubricant m ℓ (US fl oz., Imp fl oz.)		
Evaporator	75 (2.5, 2.6)		—
Condenser	35 (1.2, 1.2)		—
Liquid tank	10 (0.3, 0.4)		—

LUBRICANT

< SERVICE INFORMATION >

Part replaced	Lubricant to be added to system	Remarks
	Amount of lubricant mℓ (US fl oz., Imp fl oz.)	
In case of refrigerant leak	30 (1.0, 1.1)	Large leak
	—	Small leak* ¹

*1: If the refrigerant leak is small, no addition of lubricant is needed.

LUBRICANT ADJUSTING PROCEDURE FOR COMPRESSOR REPLACEMENT

- Before connecting recovery/recycling recharging equipment to vehicle, check recovery/recycling recharging equipment gauges. No refrigerant pressure should be displayed. If NG, recover refrigerant from equipment lines.
- Connect recovery/recycling recharging equipment to vehicle. Confirm refrigerant purity in supply tank using recovery/recycling recharging equipment and refrigerant identifier. If NG, refer to [ATC-4. "Precaution for Working with HFC-134a \(R-134a\)"](#).
- Confirm refrigerant purity in vehicle A/C system using recovery/recycling recharging equipment and refrigerant identifier. If NG, refer to [ATC-4. "Precaution for Working with HFC-134a \(R-134a\)"](#).
- Discharge refrigerant into the refrigerant recovery/recycling equipment. Measure lubricant discharged into the recovery/recycling equipment.
- Drain the lubricant from the old (removed) compressor into a graduated container and recover the amount of lubricant drained.
- Drain the lubricant from the new compressor into a separate, clean container.
- Measure an amount of new lubricant installed equal to amount drained from old compressor. Add this lubricant to new compressor through the suction port opening.
- Measure an amount of new lubricant equal to the amount recovered during discharging. Add this lubricant to new compressor through the suction port opening.
- If the liquid tank also needs to be replaced, add another 5 mℓ (0.2 US fl oz., 0.2 Imp fl oz.) of lubricant at this time.

Do not add this 5 mℓ (0.2 US fl oz., 0.2 Imp fl oz.) of lubricant when replaces the compressor only.

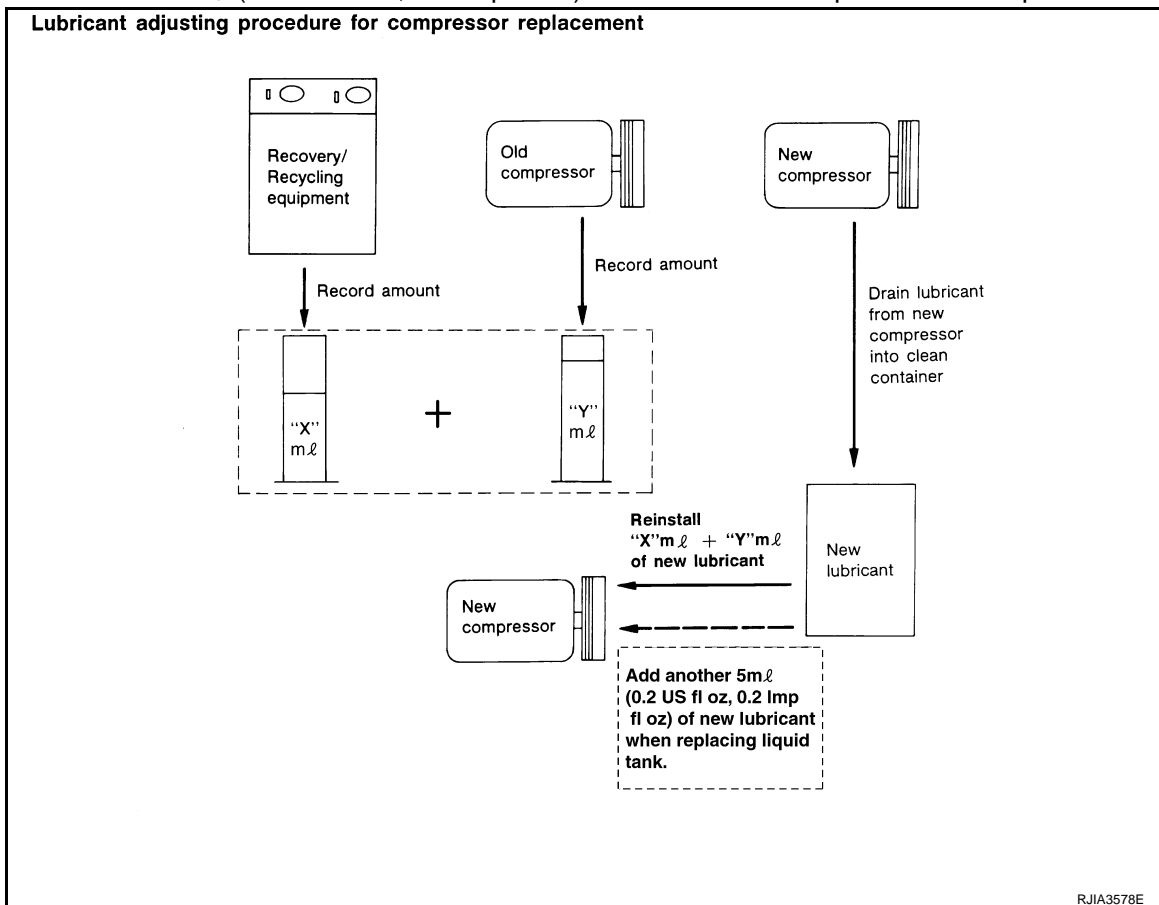

AIR CONDITIONER CONTROL

< SERVICE INFORMATION >

AIR CONDITIONER CONTROL

Description of Air Conditioner LAN Control System

INFOID:000000001328167

The LAN (Local Area Network) system consists of unified meter and A/C amp., mode door motor, air mix door motors and intake door motor.

A configuration of these components is shown in the figure below.

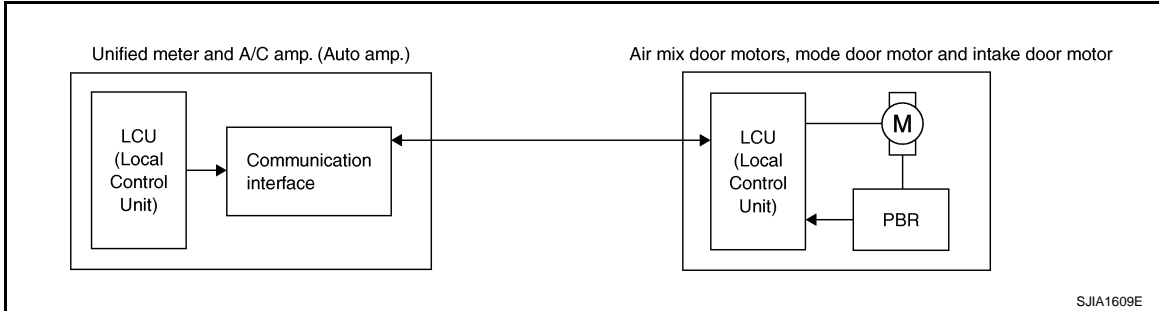

System Construction

INFOID:000000001328168

A small network is constructed between the unified meter and A/C amp., air mix door motors, mode door motor and intake door motor. The unified meter and A/C amp. and motors are connected by data transmission lines and motor power supply lines. The LAN network is built through the ground circuits of each door motor. Addresses, motor opening angle signals, motor stop signals and error checking messages are all transmitted through the data transmission lines connecting the unified meter and A/C amp. and each door motor. The following functions are contained in LCUs built into the air mix door motors, the mode door motor and the intake door motor.

- Address
- Motor opening angle signals
- Data transmission
- Motor stop and drive decision
- Opening angle sensor (PBR function)
- Comparison
- Decision (Unified meter and A/C amp. indicated value and motor opening angle comparison)

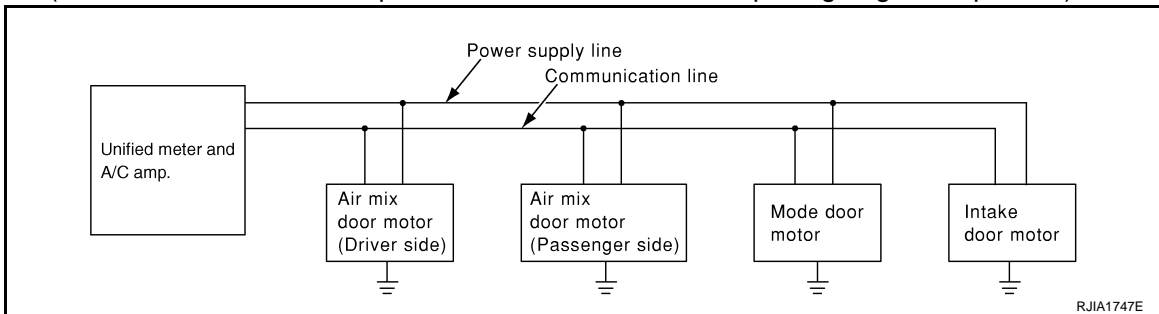

OPERATION

The unified meter and A/C amp. receives data from each of the sensors. The unified meter and A/C amp. sends mode door, air mix door and intake door opening angle data to the mode door motor LCU, air mix door motor LCU and intake door motor LCU.

The mode door motor, air mix door motors and intake door motor read their respective signals according to the address signal. Opening angle indication signals received from the unified meter and A/C amp. and each of the motor position sensors is compared by the LCUs in each door motor with the existing decision and opening angles. Subsequently, HOT/COLD, DEF/VENT and FRE/REC operation is selected. The new selection data is returned to the unified meter and A/C amp.

AIR CONDITIONER CONTROL

< SERVICE INFORMATION >

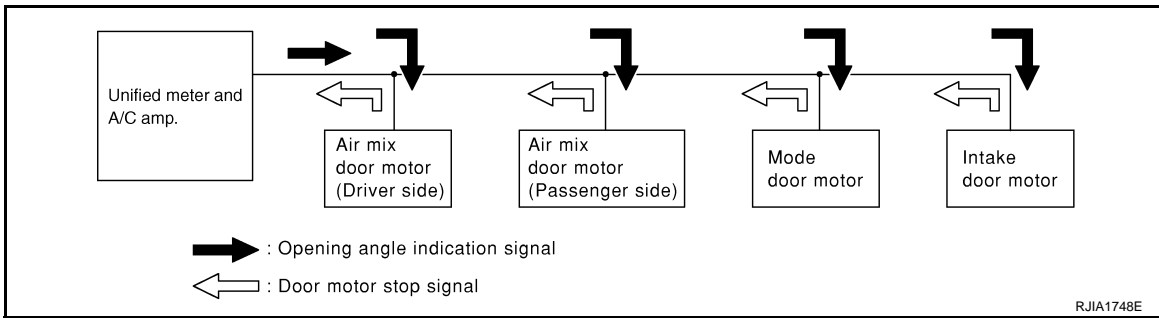

TRANSMISSION DATA AND TRANSMISSION ORDER

Unified meter and A/C amp. data is transmitted consecutively to each of the door motors following the form shown in figure below.

Start:

Initial compulsory signal is sent to each of the door motors.

Address:

Data sent from the unified meter and A/C amp. are selected according to data-based decisions made by the air mix door motor, mode door motor and intake door motor.

If the addresses are identical, the opening angle data and error check signals are received by the door motor LCUs. The LCUs then make the appropriate error decision. If the opening angle data have no error, door control begins.

If an error exists, the received data are rejected and corrected data received. Finally, door control is based upon the corrected opening angle data.

Opening Angle:

Data that shows the indicated door opening angle of each door motor.

Error Check:

In this procedure, transmitted and received data is checked for errors. Error data are then compiled. The error check prevents corrupted data from being used by the air mix door motor, the mode door motor and the intake door motor. Error data can be related to the following symptoms.

- Malfunction of electrical frequency
- Poor electrical connections
- Signal leakage from transmission lines
- Signal level fluctuation

Stop Signal:

At the end of each transmission, a stop operation, in-operation, or internal malfunction message is delivered to the unified meter and A/C amp. This completes one data transmission and control cycle.

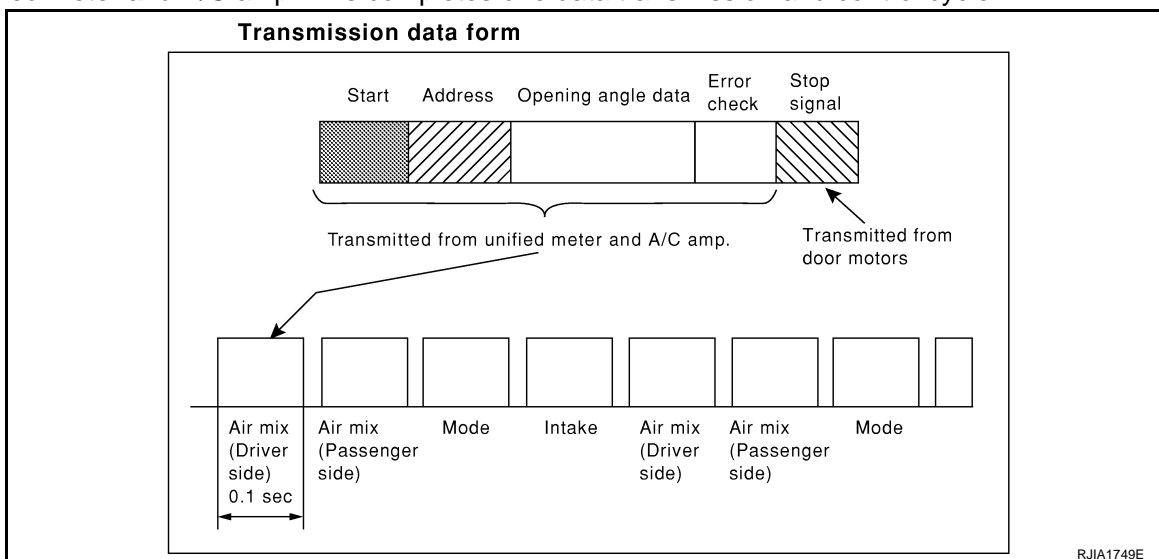

AIR MIX DOOR CONTROL (AUTOMATIC TEMPERATURE CONTROL)

AIR CONDITIONER CONTROL

< SERVICE INFORMATION >

The air mix doors are automatically controlled so that in-vehicle temperature is maintained at a predetermined value by the temperature setting, ambient temperature, in-vehicle temperature and amount of sunload.

FAN SPEED CONTROL

Blower speed is automatically controlled by the temperature setting, ambient temperature, in-vehicle temperature, intake temperature, amount of sunload and air mix door position.

With pressing AUTO switch, the blower motor starts to gradually increase air flow volume.

When engine coolant temperature is low, the blower motor operation is delayed to prevent cool air from flowing.

INTAKE DOOR CONTROL

The intake doors are automatically controlled by the temperature setting, ambient temperature, in-vehicle temperature, intake temperature, amount of sunload and ON/OFF operation of the compressor.

MODE DOOR CONTROL

The mode door is automatically controlled by the temperature setting, ambient temperature, in-vehicle temperature, intake temperature and amount of sunload.

MAGNET CLUTCH CONTROL

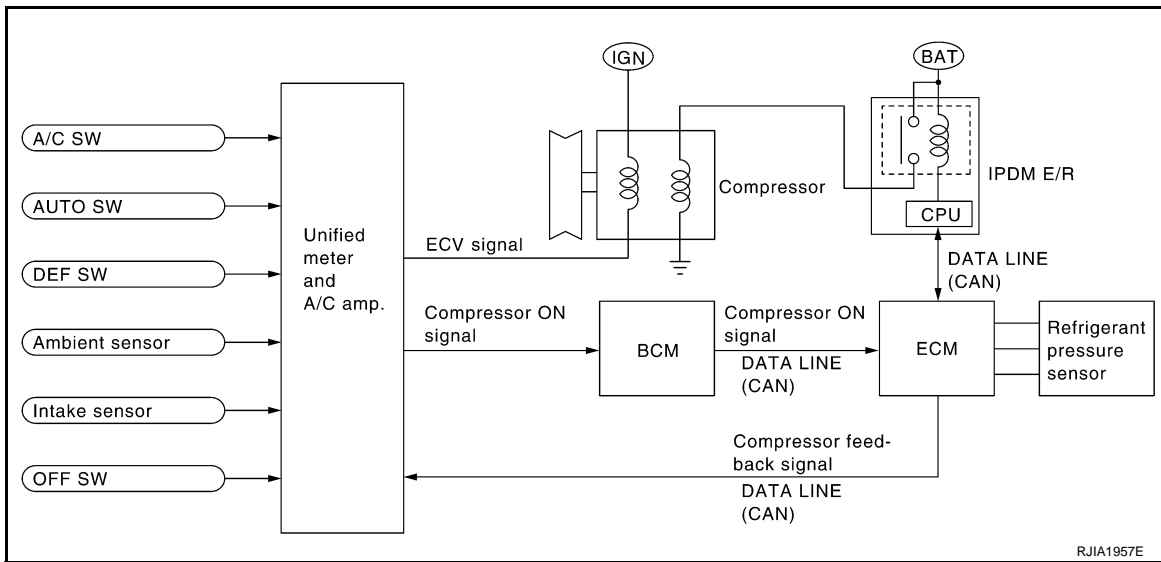

When A/C switch, AUTO switch or DEF switch is pressed, unified meter and A/C amp. transmits compressor ON signal to BCM.

BCM sends compressor ON signal to ECM, via CAN communication.

ECM judges whether compressor can be turned ON, based on each sensor status (refrigerant-pressure sensor signal, throttle angle, etc.). If it judges compressor can be turned ON, it sends compressor ON signal to IPDM E/R, via CAN communication.

Upon receipt of compressor ON signal from ECM, IPDM E/R turns air conditioner relay ON to operate compressor.

When sending compressor ON signal to IPDM E/R via CAN communication, ECM simultaneously sends compressor feedback signal to unified meter and A/C amp. via CAN communication.

Unified meter and A/C amp., then, uses input compressor feedback signal to control air inlet.

SELF-DIAGNOSIS SYSTEM

The self-diagnosis system is built into the unified meter and A/C amp. to quickly locate the cause of malfunctions.

AIR CONDITIONER CONTROL

< SERVICE INFORMATION >

Description of Control System

INFOID:000000001328169

The control system consists of input sensors, switches, the unified meter and A/C amp. (microcomputer) and outputs. The relationship of these components is shown in the figure below:

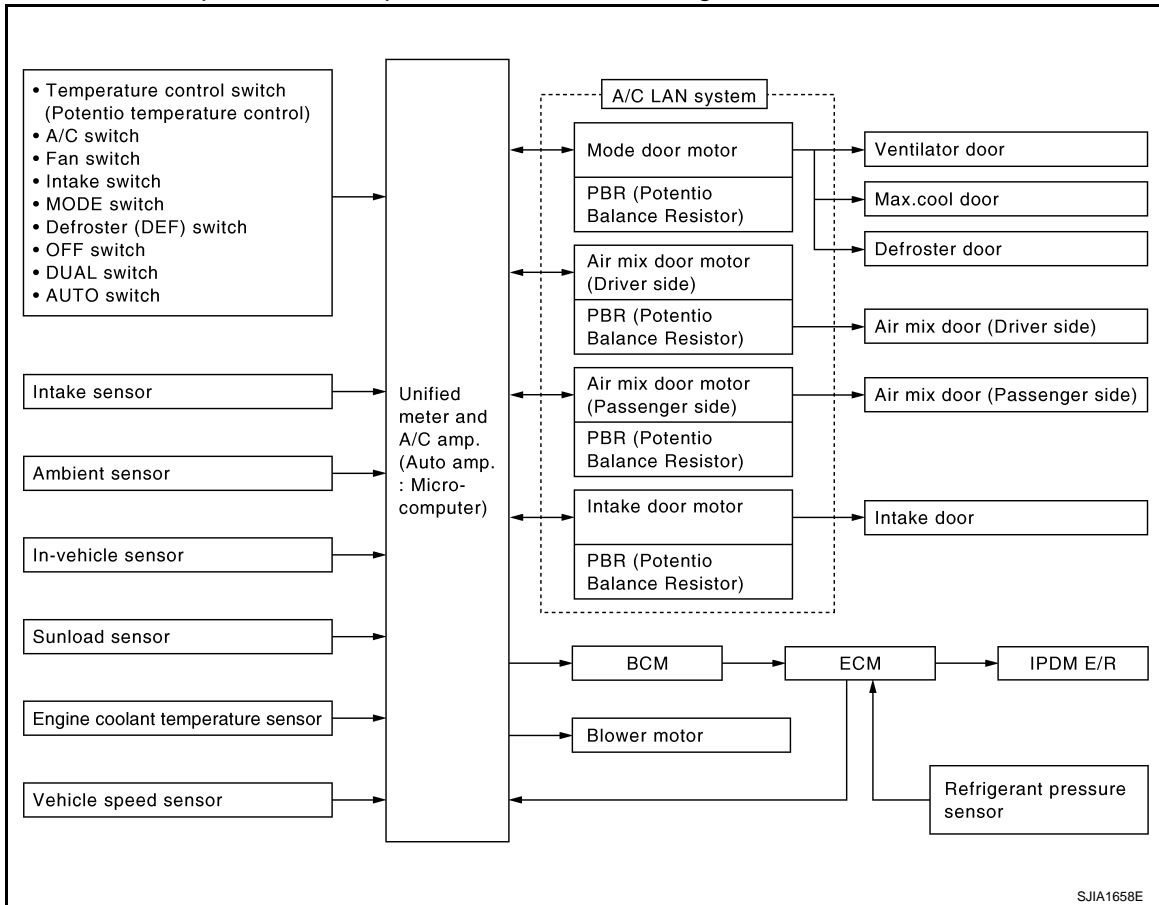

Control Operation

INFOID:000000001328170

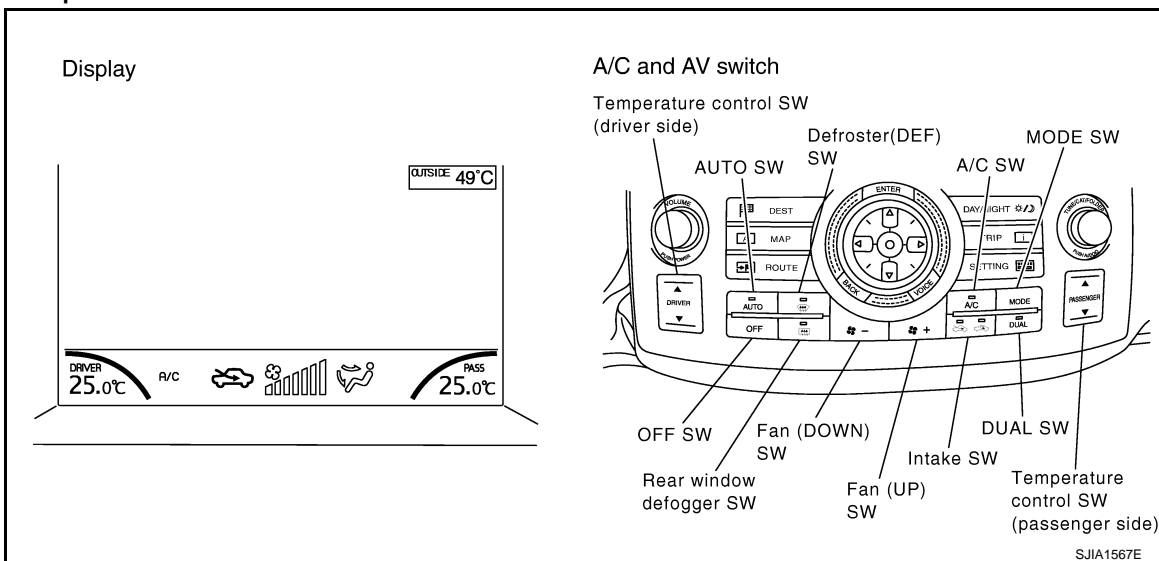

DISPLAY SCREEN

The operation status of the system is displayed on the screen.

AUTO SWITCH

- The compressor, intake doors, air mix doors, mode doors and blower speed are automatically controlled so that the in-vehicle temperature will reach, and be maintained at the set temperature selected by the operator.

AIR CONDITIONER CONTROL

< SERVICE INFORMATION >

- When pressing AUTO switch, air inlet, air outlet, fan speed, and discharge air temperature are automatically controlled.

TEMPERATURE CONTROL SWITCH (POTENTIO TEMPERATURE CONTROL) (DRIVER SIDE)

The set temperature is increased or decreased with this switch.

TEMPERATURE CONTROL SWITCH (POTENTIO TEMPERATURE CONTROL) (PASSENGER SIDE)

- The set temperature is increased or decreased with this switch.
- When the temperature switch is pressed, the DUAL switch indicator will automatically illuminate.

INTAKE SWITCH

- When intake switch is ON, REC LED turns ON, and air inlet is fixed to REC.
- When press intake switch again, FRE LED turns ON, and air inlet is fixed to FRE.
- When intake switch is pressed for approximately 1.5 seconds or longer, FRE and REC LEDs blink twice. Then, automatic control mode is entered. Inlet status is displayed by LED even during automatic controlled.
- When FRE LED is turned ON, shifting mode position to D/F or DEF, or when compressor is turned from ON to OFF, intake switch is automatically turned OFF (fixed to FRE mode). REC mode can be re-entered by pressing intake switch again, and then compressor is turned ON. (Except D/F or DEF position)

DEFROSTER (DEF) SWITCH

Mode doors are set to the defrost position with this switch. Also, intake doors are set to the outside air position, and compressor turns ON.

REAR WINDOW DEFOGGER SWITCH

When illumination is ON, rear window is defogged.

OFF SWITCH

Compressor and blower are OFF, the intake doors and the mode doors are automatically controlled.

A/C SWITCH

Compressor is ON or OFF with this switch.

(Pressing the A/C switch when the A/C switch is ON will turn OFF the A/C switch and compressor.)

MODE SWITCH

The air discharge outlets is controlled with this switch.

FAN SWITCH

The blower speed is manually controlled with this switch. Seven speeds are available for manual control (as shown on the display screen).

DUAL SWITCH

- When the DUAL switch indicator is illuminated, the driver side and passenger side temperature can each be set independently.
- When the DUAL switch indicator is not illuminated, the driver side setting temperature is applied to both sides.

Fail-Safe Function

INFOID:000000001328171

If a communication error exists between the unified meter and A/C amp., and the A/C and AV switch for 30 seconds or longer, air conditioner is controlled under following conditions:

Compressor	: ON
Air outlet	: AUTO
Air inlet	: FRE (Fresh)
Blower fan speed	: AUTO
Set temperature	: Setting before communication error occurs
Display	: OFF

AIR CONDITIONER CONTROL

< SERVICE INFORMATION >

Discharge Air Flow

INFOID:000000001328172

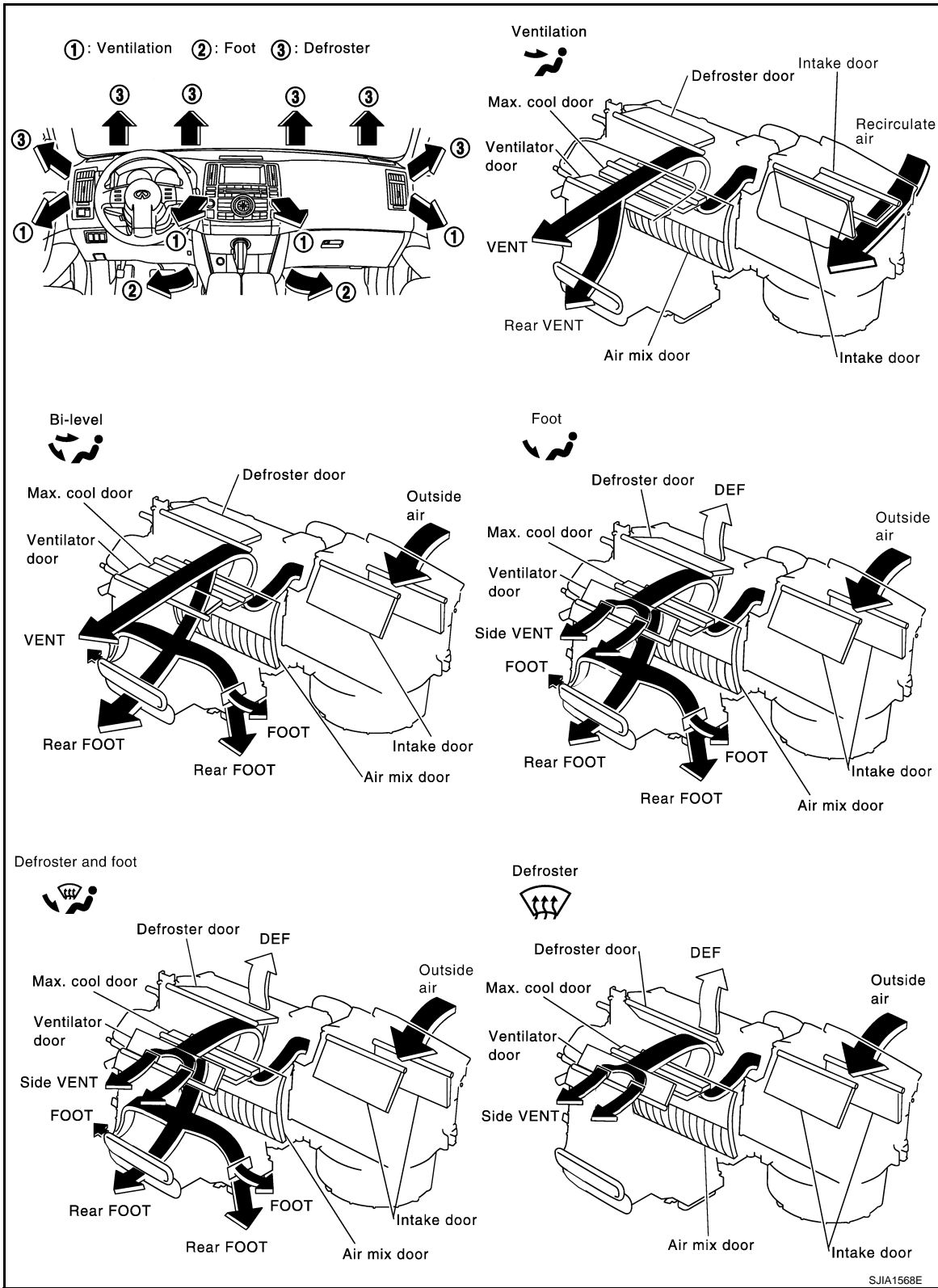

A
B
C
D
E
F
G
H
I
K
L
M
N
O
P

ATC

AIR CONDITIONER CONTROL

< SERVICE INFORMATION >

System Description

INFOID:000000001328173

SWITCHES AND THEIR CONTROL FUNCTION

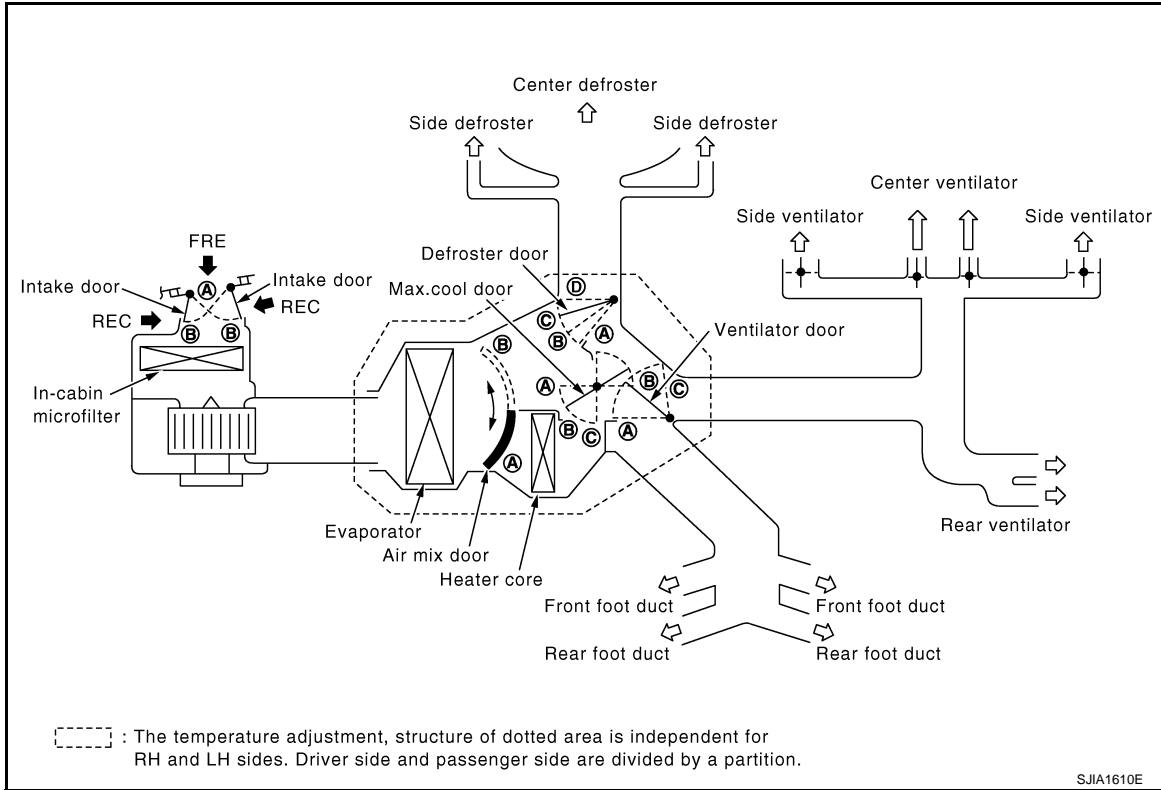

SJIA1610E

Position or switch	DUAL SW		MODE SW				DEF SW		AUTO SW	Intake SW		Temperature control SW(Driver side)		Temperature control SW(Passenger side)		OFF SW
	ON	OFF	VENT	B/L	FOOT	D/F	ON	OFF		FRE	REC	18°C (60°F)	32°C (90°F)	18°C (60°F)	32°C (90°F)	
	DUAL		MODE				DEF			INTAKE		DRIVER		PASSENGER		
Door																
Ventilator door	—	—	(A)	(B)	(C)	(C)	(C)	—	—	—	—	—	—	—	—	AUTO
Max.cool door	—	—	(A)	(B)	(B)	(B)	(C)	—	—	—	—	—	—	—	—	AUTO
Defroster door	—	—	(D)	(D)	(D,C ^{*1})	(B)	(A)	—	—	—	—	—	—	—	—	AUTO
Intake door	—	—	—	—	—	(B)	(B)	—	—	(B) ^{*2}	(A) ^{*2}	—	—	—	—	AUTO
Air mix door (Driver side)	—	—	—	—	—	—	—	—	AUTO	—	(A)	AUTO	(B)	—	—	—
Air mix door (Passenger side)	ON	—	—	—	—	—	—	—	AUTO	—	—	—	(A)	AUTO	(B)	—
	OFF	—	—	—	—	—	—	—	—	—	(A)	AUTO	(B)	—	—	—

*1: This position is selected only when the mode door is automatically controlled.

*2: Inlet status is displayed under the automatic control.

SJIA1890E

CAN Communication System Description

INFOID:000000001328174

CAN (Controller Area Network) is a serial communication line for real time application. It is an on-vehicle multiplex communication line with high data communication speed and excellent error detection ability. Many elec-

AIR CONDITIONER CONTROL

< SERVICE INFORMATION >

tronic control units are equipped onto a vehicle, and each control unit shares information and links with other control units during operation (not independent). In CAN communication, control units are connected with 2 communication lines (CAN-H line, CAN-L line) allowing a high rate of information transmission with less wiring. Each control unit transmits/receives data but selectively reads required data only. For details, refer to [LAN-43, "CAN System Specification Chart"](#).

A
B
C
D
E
F
G
H
I
K
L
M
N
O
P

ATC

TROUBLE DIAGNOSIS

< SERVICE INFORMATION >

TRouble DIAGNOSIS

CONSULT-III Function

INFOID:000000001328175

CONSULT-III can display each diagnosis item using the diagnosis test modes shown following.

System part	Check item, diagnosis mode	Description
BCM	Data monitor	Displays BCM input data in real time.

DATA MONITOR

Display Item List

Monitor item name "operation or unit"	Contents
IGN ON SW "On/Off"	Displays "IGN position (On)/OFF, ACC position (Off)" status as judged from ignition switch signal.
FAN ON SIG "On/Off"	Displays "FAN (On)/FAN (Off)" status as judged from blower fan motor switch signal.
AIR COND SW "On/Off"	Displays "COMP (On)/COMP (Off)" status as judged from air conditioner switch signal.

How to Perform Trouble Diagnosis for Quick and Accurate Repair

INFOID:000000001328176

WORK FLOW

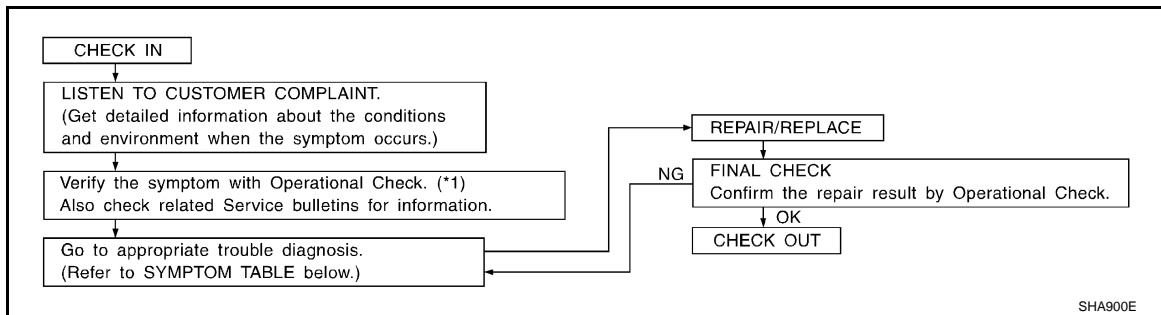

*1 [ATC-50, "Operational Check"](#)

SYMPTOM TABLE

Symptom	Reference Page
A/C system does not come on.	Go to Trouble Diagnosis Procedure for A/C System. ATC-52, "Power Supply and Ground Circuit for Auto Amp"
A/C system cannot be controlled.	<ul style="list-style-type: none"> Go to Integrated Display System. Go to Navigation System. AV-79, "Unable to Operate System with A/C and AV Switch" (Without navigation system) or AV-127, "Unable to Operate System with A/C and AV Switch" (With navigation system)
Air outlet does not change.	Go to Trouble Diagnosis Procedure for Mode Door Motor. (LAN) ATC-57, "Mode Door Motor Circuit"
Mode door motor does not operate normally.	
Discharge air temperature does not change.	Go to Trouble Diagnosis Procedure for Air Mix Door Motor. (LAN) ATC-59, "Air Mix Door Motor Circuit"
Air mix door motor does not operate normally.	

TROUBLE DIAGNOSIS

< SERVICE INFORMATION >

Symptom	Reference Page	
Intake door does not change.	Go to Trouble Diagnosis Procedure for Intake Door Motor. (LAN)	ATC-62. "Intake Door Motor Circuit"
Intake door motor does not operate normally.		
Blower motor operation is malfunctioning.	Go to Trouble Diagnosis Procedure for Blower Motor.	ATC-64. "Blower Motor Circuit"
Magnet clutch does not engage.	Go to Trouble Diagnosis Procedure for Magnet Clutch.	ATC-69. "Magnet Clutch Circuit"
Insufficient cooling	Go to Trouble Diagnosis Procedure for Insufficient Cooling.	ATC-75. "Insufficient Cooling"
Insufficient heating	Go to Trouble Diagnosis Procedure for Insufficient Heating.	ATC-82. "Insufficient Heating"
Noise	Go to Trouble Diagnosis Procedure for Noise.	ATC-83. "Noise"
Self-diagnosis cannot be performed.	Go to Trouble Diagnosis Procedure for Self-diagnosis.	ATC-84. "Self-Diagnosis"
Memory function does not operate.	Go to Trouble Diagnosis Procedure for Memory Function.	ATC-85. "Memory Function"

A
B
C
D
E
F

G

H

I

ATC

K

L

M

N

O

P

TROUBLE DIAGNOSIS

< SERVICE INFORMATION >

Component Parts and Harness Connector Location

INFOID:000000001328177

ENGINE COMPARTMENT

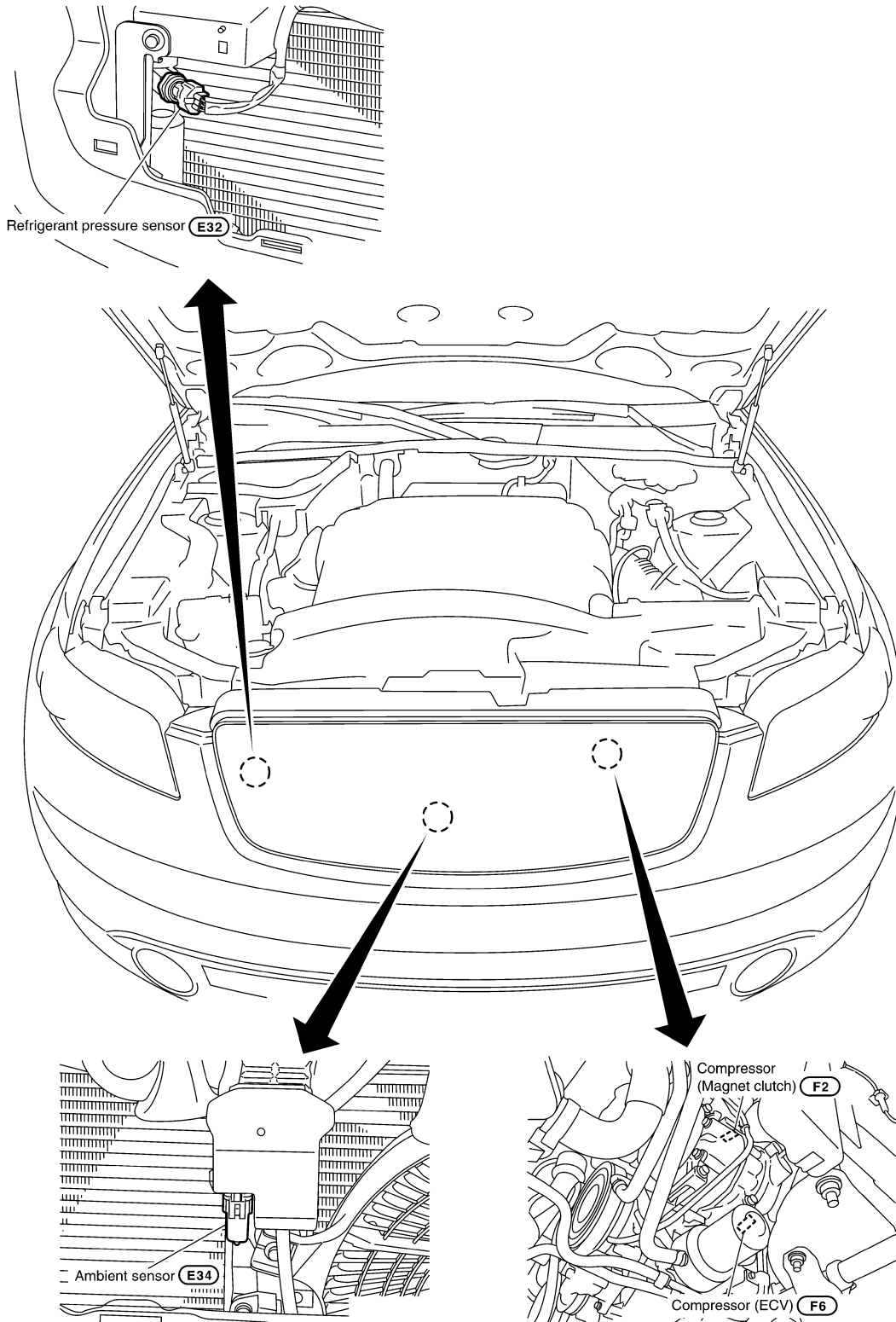

RJA1963E

TROUBLE DIAGNOSIS

< SERVICE INFORMATION > PASSENGER COMPARTMENT

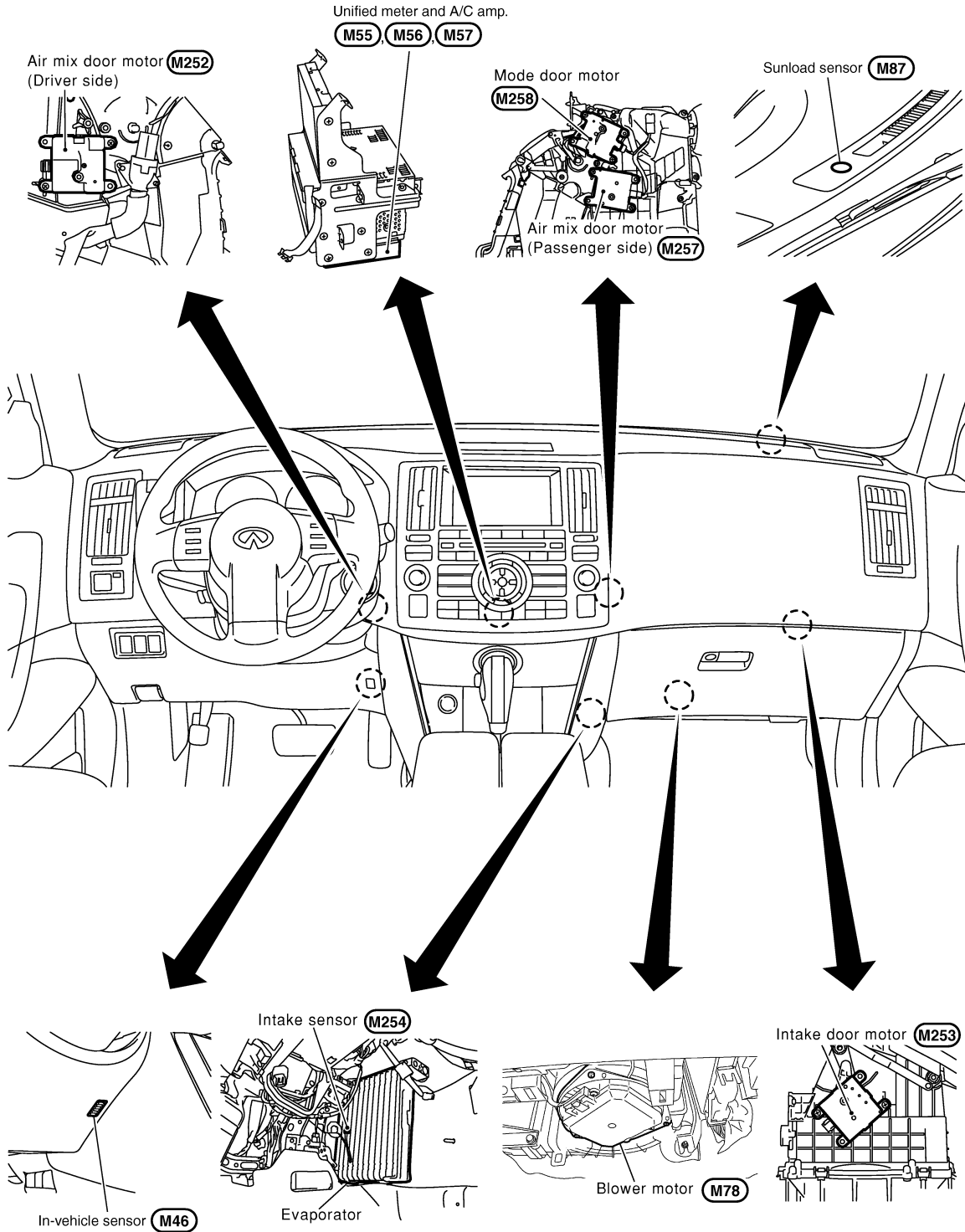

A
B
C
D
E
F
G
H
I
K
L
M
N
O
P

ATC

SJA1606E

TROUBLE DIAGNOSIS

< SERVICE INFORMATION >

Schematic

INFOID:000000001328178

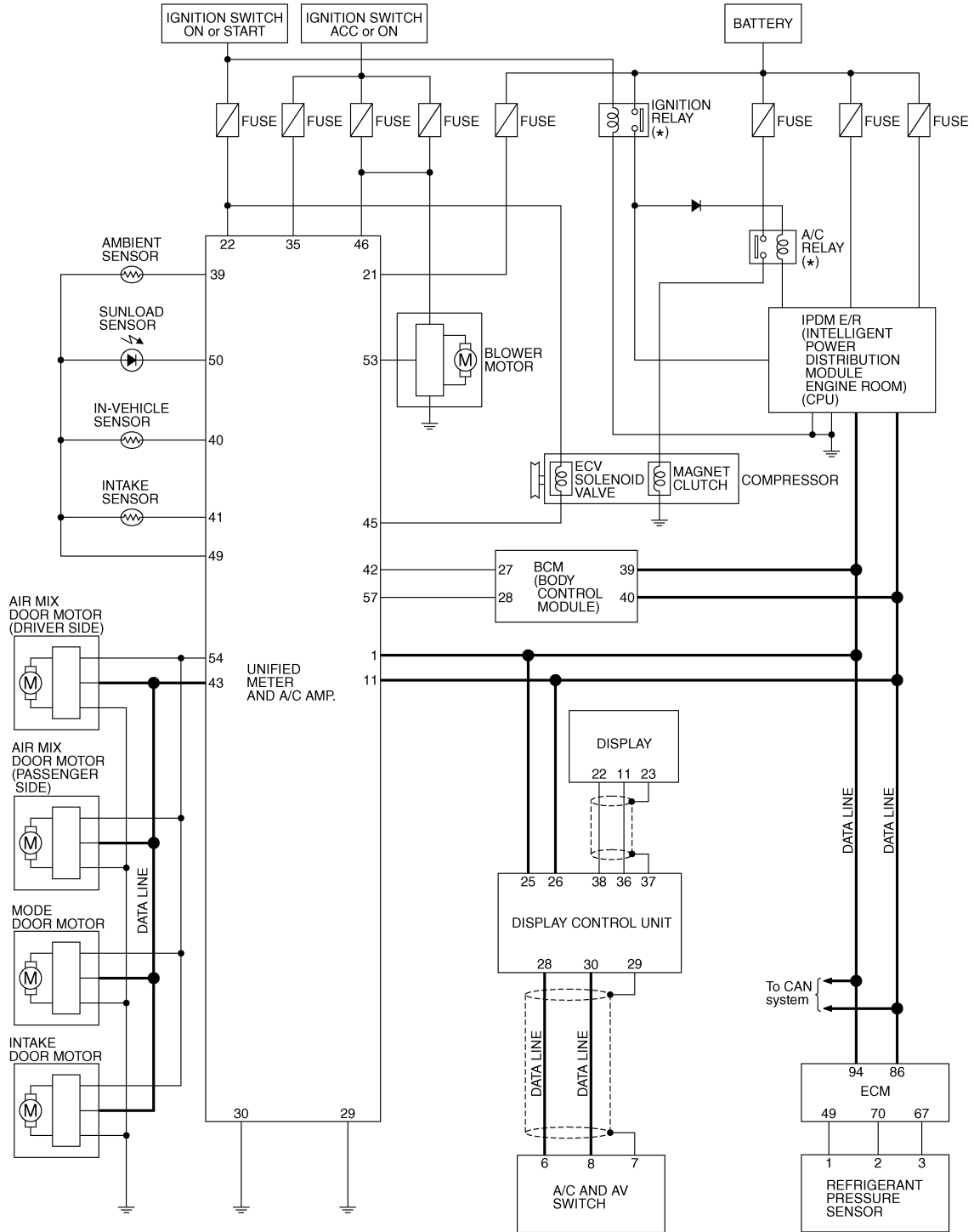

* : This relay is built into the IPDM E/R (Intelligent power distribution module engine room).

TJWM0253E

TROUBLE DIAGNOSIS

< SERVICE INFORMATION >

Wiring Diagram - A/C -

INFOID:000000001328179

ATC-A/C-01

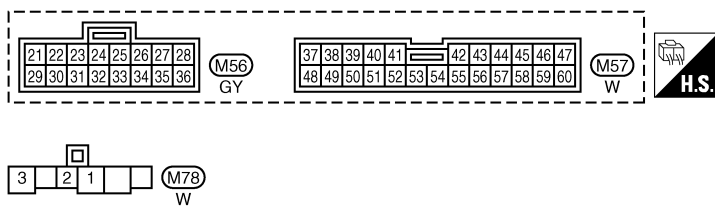
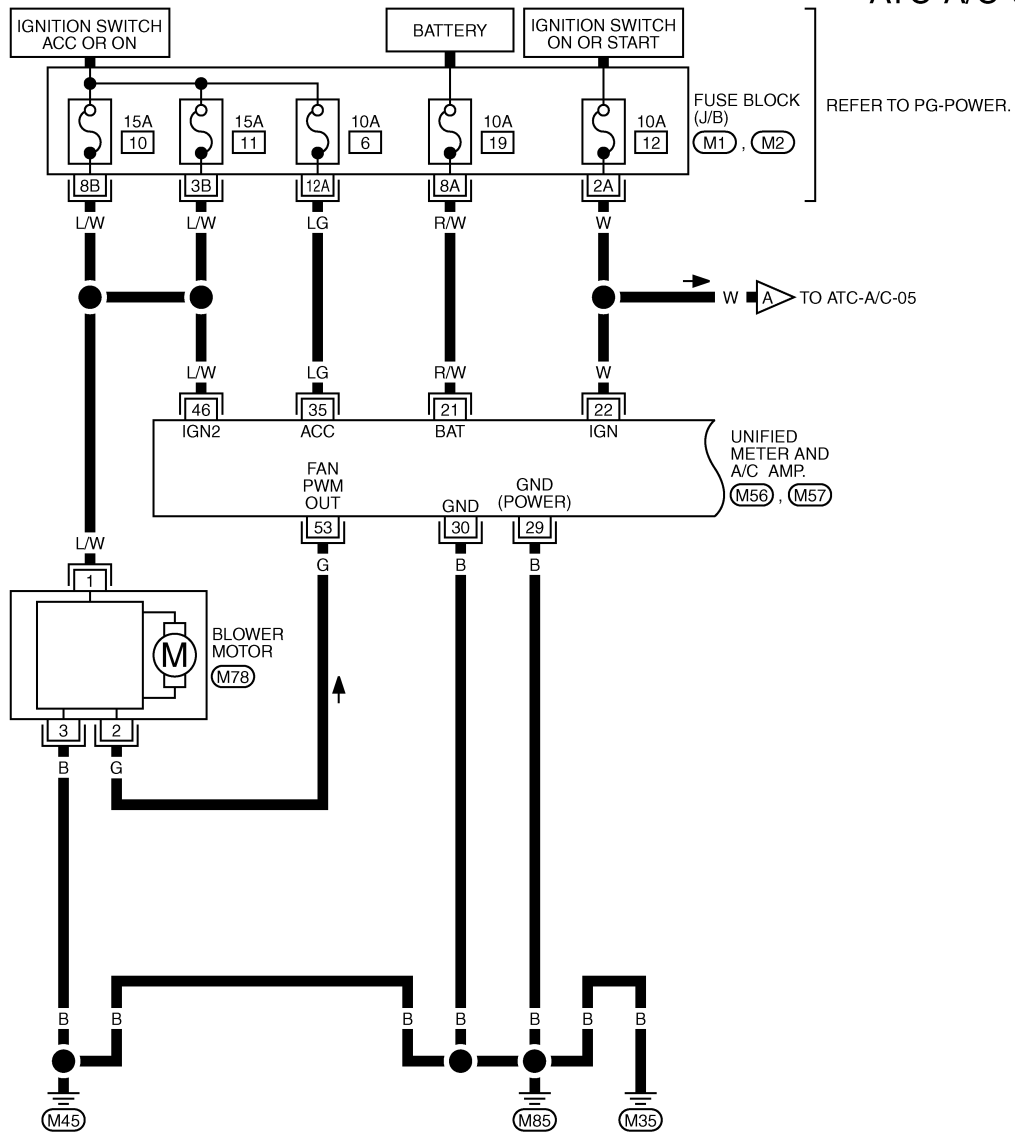

REFER TO THE FOLLOWING.
 (M1), (M2) - FUSE BLOCK-JUNCTION BOX (J/B)

TJWM0254E

A
B
C
D
E
F
G
H
I
ATC
K
L
M
N
O
P

TROUBLE DIAGNOSIS

< SERVICE INFORMATION >

ATC-A/C-02

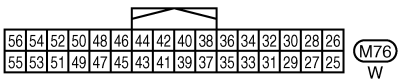
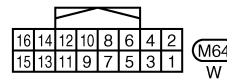
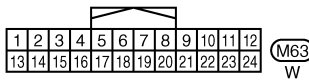
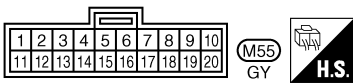
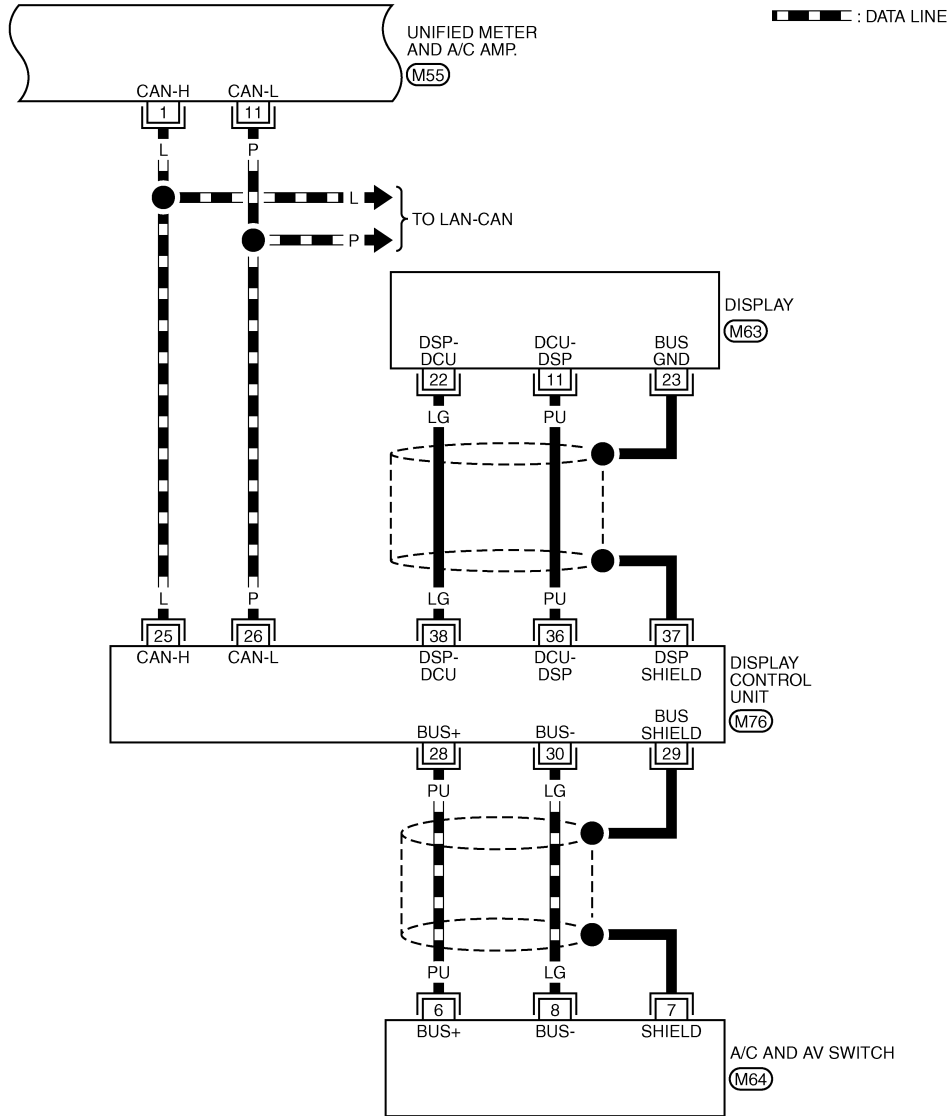

TJWM0255E

TROUBLE DIAGNOSIS

< SERVICE INFORMATION >

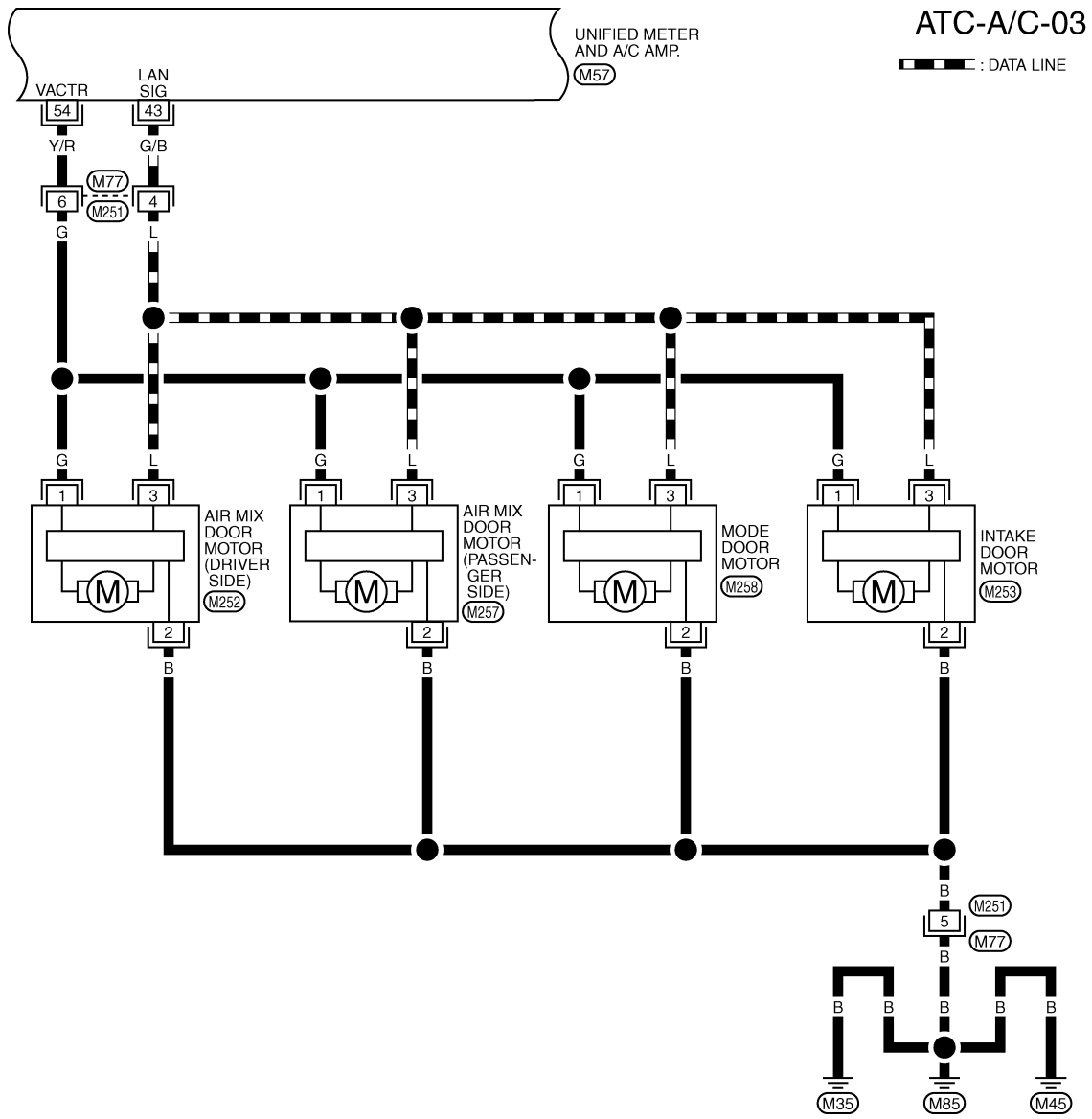

A
B
C
D
E
F
G
H
I
K
L
M
N
O
P

ATC

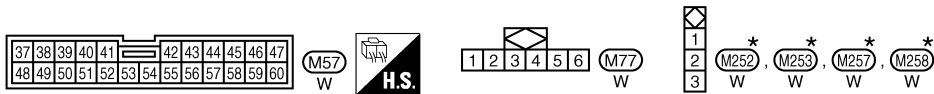

*: THIS CONNECTOR IS NOT SHOWN IN "HARNES LAYOUT", PG SECTION.

TJWM0054E

TROUBLE DIAGNOSIS

< SERVICE INFORMATION >

ATC-A/C-04

▬ : DATA LINE

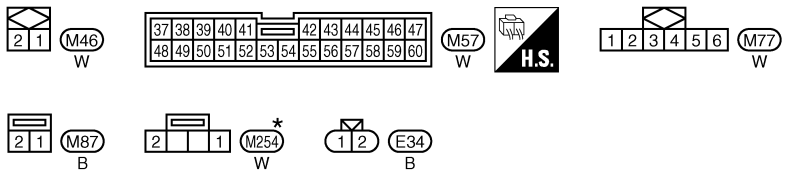
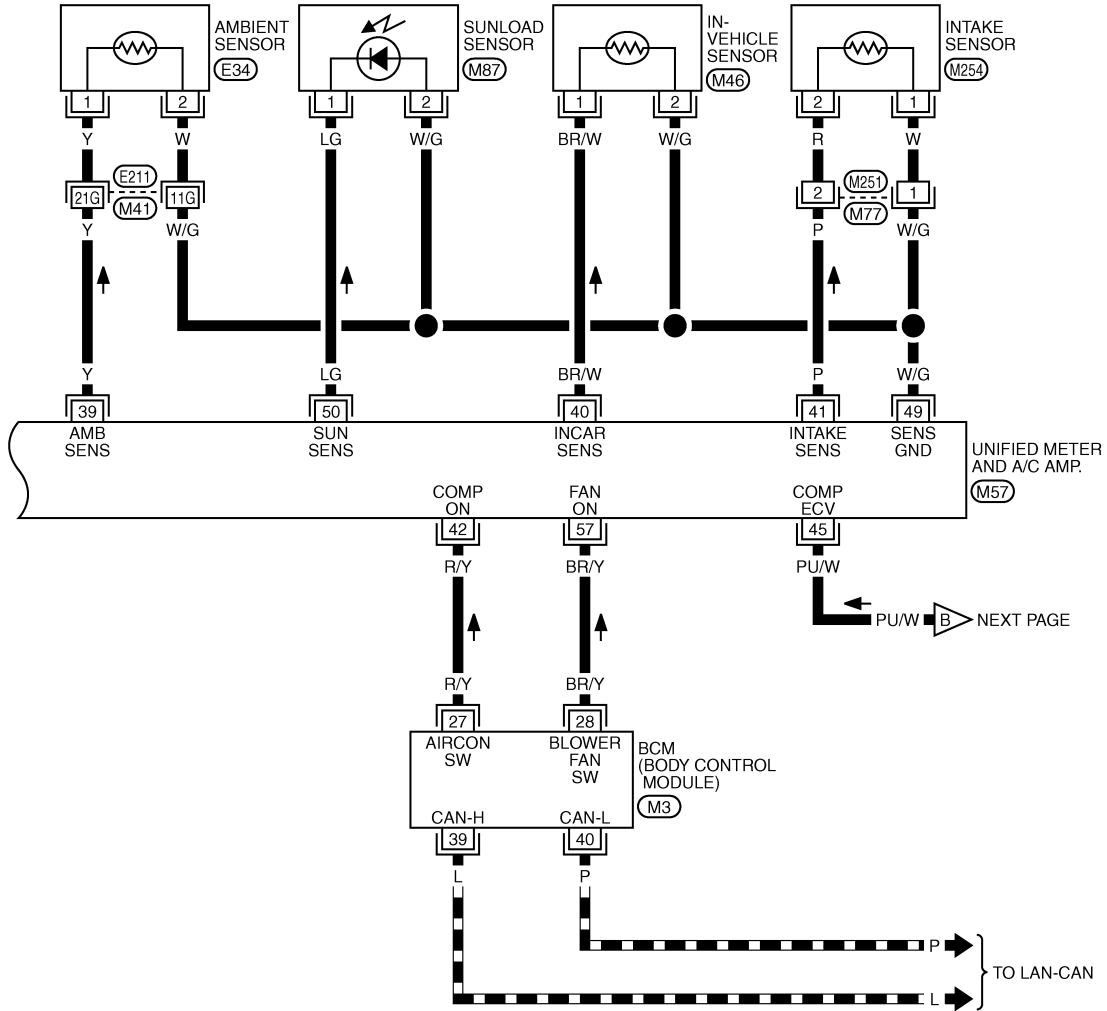

REFER TO THE FOLLOWING.
 (E211) -SUPER MULTIPLE JUNCTION (SMJ)
 (M3) -ELECTRICAL UNITS

*: THIS CONNECTOR IS NOT SHOWN IN "HARNESS LAYOUT", PG SECTION.

TJWM0256E

TROUBLE DIAGNOSIS

< SERVICE INFORMATION >

ATC-A/C-05

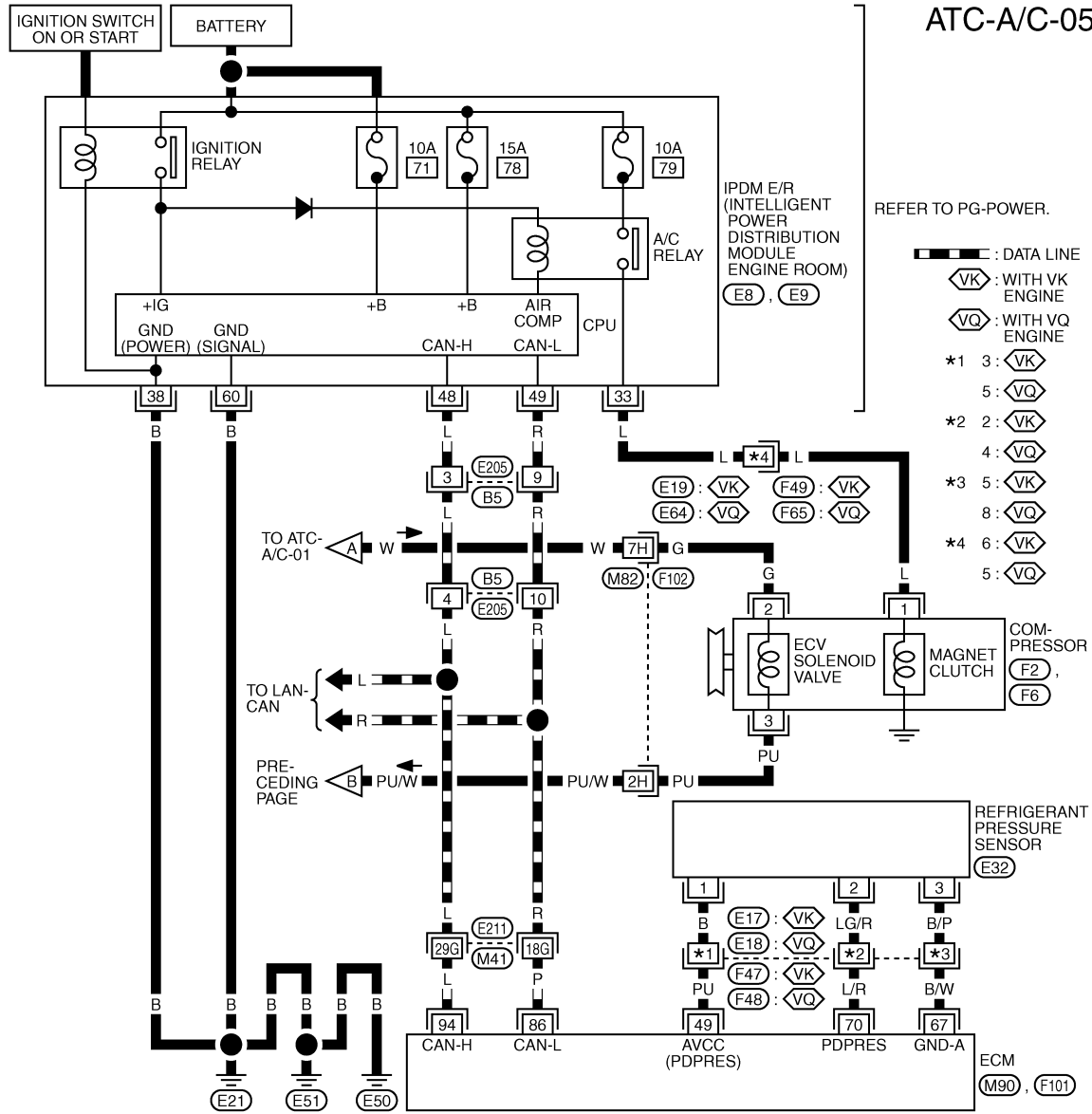

REFER TO PG-POWER.

— : DATA LINE

◊VK◊ : WITH VK ENGINE

◊VQ◊ : WITH VQ ENGINE

*1 3 : ◊VK◊

5 : ◊VQ◊

*2 2 : ◊VK◊

4 : ◊VQ◊

*3 5 : ◊VK◊

8 : ◊VQ◊

*4 6 : ◊VK◊

5 : ◊VQ◊

A
B
C
D
E
F
G
H
I
ATC
K
L
M
N
O
P

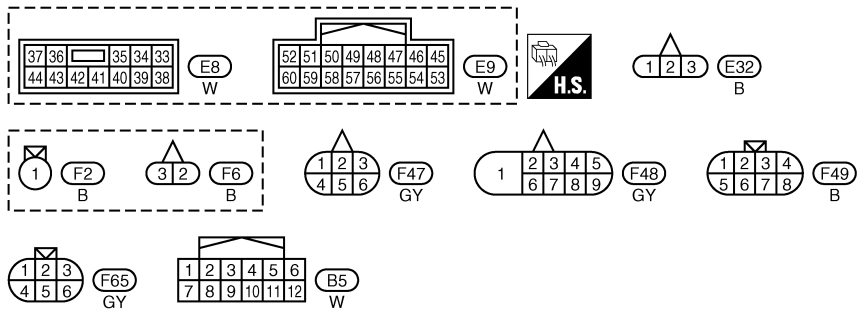

REFER TO THE FOLLOWING.
 (E21), (F102) -SUPER MULTIPLE JUNCTION (SMJ)
 (M90), (F101) -ELECTRICAL UNITS

TJWM0257E

TROUBLE DIAGNOSIS

< SERVICE INFORMATION >

Auto Amp. Terminal and Reference Value

INFOID:000000001328180

Measure voltage between each terminal and ground by referring terminals and reference value for unified meter and A/C amp.

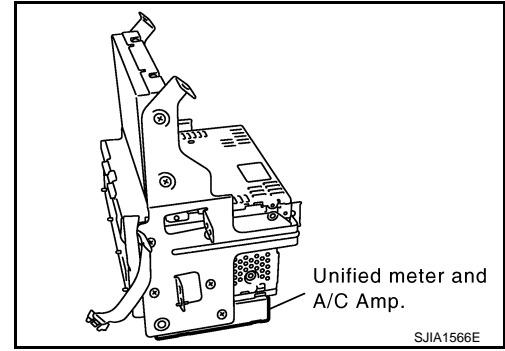

PIN CONNECTOR TERMINAL LAYOUT

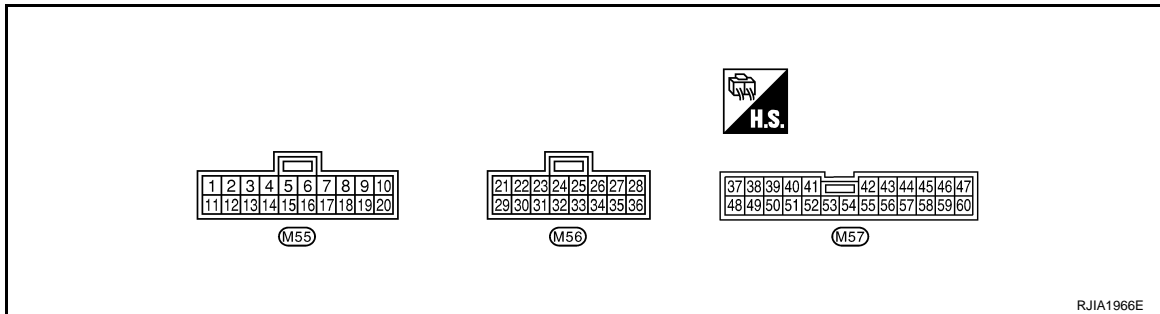

TERMINALS AND REFERENCE VALUE FOR UNIFIED METER AND A/C AMP.

Terminal No.	Wire color	Item	Ignition switch	Condition	Voltage (V)
1	L	CAN-H	—	—	—
11	P	CAN-L	—	—	—
21	R/W	Power supply from BAT	OFF	—	Battery voltage
22	W	Power supply from IGN	ON	—	Battery voltage
29	B	Ground (Power)	ON	—	Approx. 0
30	B	Ground	ON	—	Approx. 0
35	LG	Power supply from ACC	ACC	—	Battery voltage
39	Y	Ambient sensor	—	—	—
40	BR/W	In-vehicle sensor	—	—	—
41	P	Intake sensor	—	—	—
42	R/Y	Compressor ON signal	ON	A/C switch: ON (Blower motor operates.)	Approx. 0
				OFF switch: ON (A/C system: OFF)	

SJIA1423J

TROUBLE DIAGNOSIS

< SERVICE INFORMATION >

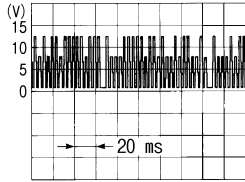
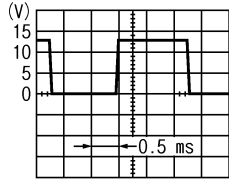
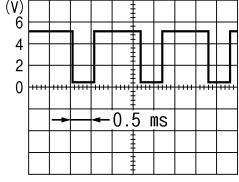
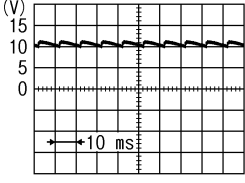
Terminal No.	Wire color	Item	Ignition switch	Condition	Voltage (V)
43	G/B	A/C LAN signal	ON	—	 <p style="text-align: right; font-size: small;">SJIA1453J</p>
45	PU/W	ECV (Electric Control Valve) signal	ON	Self-diagnosis. STEP-4 (Code No. 45)	 <p style="text-align: right; font-size: small;">SJIA1607E</p>
46	L/W	Power supply for IGN2	ON	—	Battery voltage
49	W/G	Sensor ground	ON	—	Approx. 0
50	LG	Sunload sensor	—	—	—
53	G	Blower motor control signal	ON	Blower speed: 1st speed (manual)	 <p style="text-align: right; font-size: small;">SJIA1454J</p>
54	Y/R	Power supply for each door motor	ON	—	Battery voltage
57	BR/Y	Blower motor ON signal	ON	A/C switch: ON (Blower motor operates.)	Approx. 0
				OFF switch: ON (A/C system: OFF)	 <p style="text-align: right; font-size: small;">SJIA1474J</p>

Self-Diagnosis Function

INFOID:000000001328181

DESCRIPTION

The self-diagnosis system diagnoses sensors, door motors, blower motor, etc. by system line. Refer to applicable sections (items) for details. Shifting from normal control to the self-diagnosis system is accomplished by starting the engine (turning the ignition switch ON) and pressing OFF switch for at least 5 seconds. The OFF switch must be pressed within 10 seconds after starting the engine (ignition switch is turned ON). This system will be canceled by either pressing AUTO switch or turning the ignition switch OFF. Shifting from one step is accomplished by means of pressing temperature control switch (driver side), as required.

TROUBLE DIAGNOSIS

< SERVICE INFORMATION >

Shifting from STEP-5 to AUXILIARY MECHANISM is accomplished by means of pressing  (fan) UP switch.

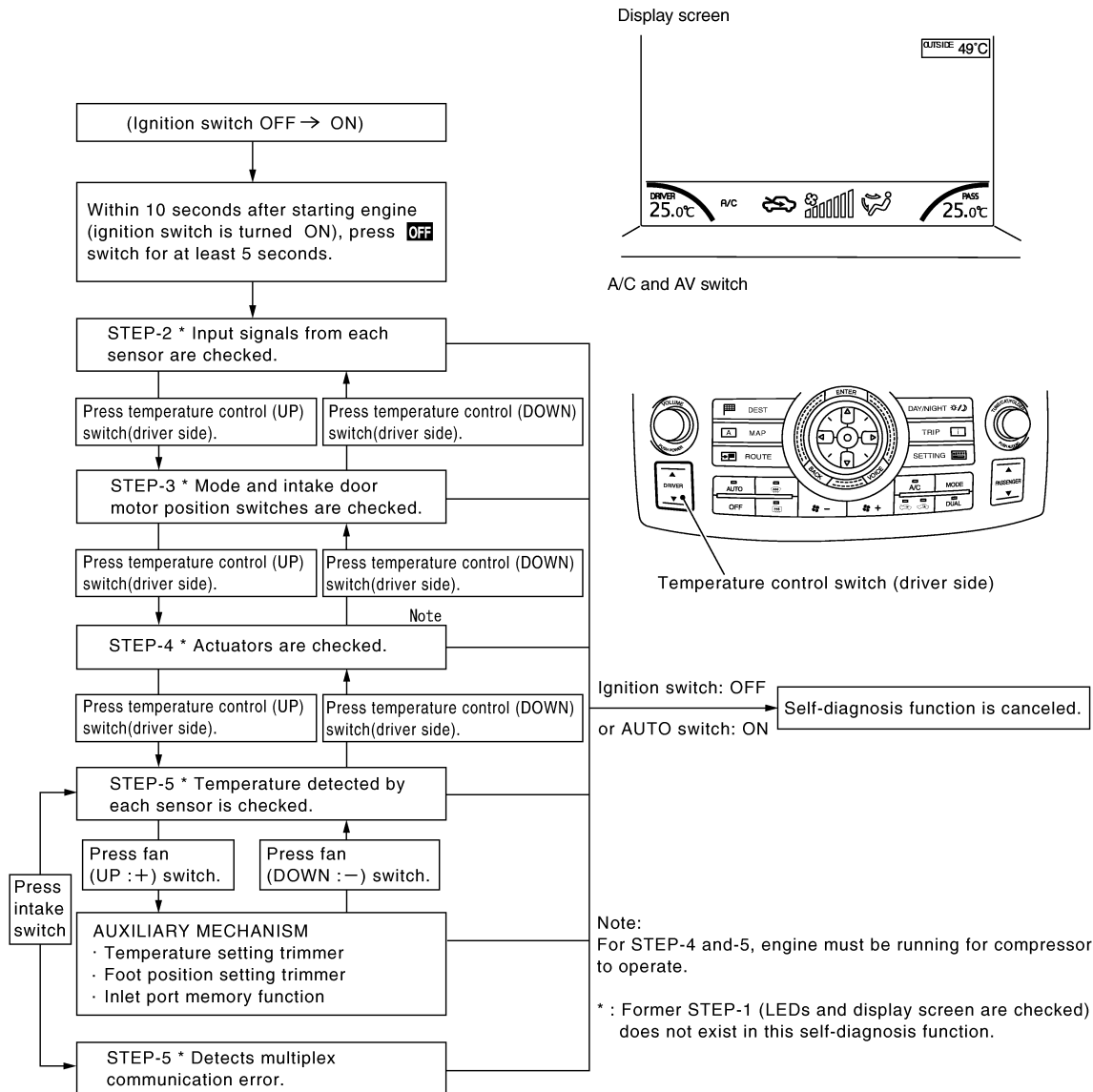

SJIA1571E

FUNCTION CONFIRMATION PROCEDURE

1.SET IN SELF-DIAGNOSIS MODE

1. Turn ignition switch ON.
2. Set in self-diagnosis mode as follows. Within 10 seconds after starting engine (ignition switch is turned ON.), press OFF switch for at least 5 seconds.

NOTE:

- If battery voltage drops below 12 V during diagnosis STEP-3, door motor speed becomes slower and as a result, the system may generate an error even when operation is normal. To avoid this, start engine before performing this diagnosis.
- Former STEP-1 (LEDs and display screen are checked) does not exist in this self-diagnosis function.

>> GO TO 2.

2.STEP-2: SENSOR CIRCUITS ARE CHECKED FOR OPEN OR SHORT CIRCUIT

TROUBLE DIAGNOSIS

< SERVICE INFORMATION >

Does code No. 20 appear on the display?

- YES >> GO TO 3.
- NO >> GO TO 13.

Display (when all sensors are in good order)

Indicates 25 seconds after "2" is indicated.

Indicates

20

SJIA1778E

3.CHECK TO ADVANCE SELF-DIAGNOSIS STEP-3

Press temperature control (UP) switch (driver side).

Advance to self-diagnosis STEP-3?

- YES >> GO TO 4.
- NO >> Replace A/C and AV switch. (Temperature control switch is malfunctioning.)

4.CHECK TO RETURN SELF-DIAGNOSIS STEP-2

Press temperature control (DOWN) switch (driver side).

Return to self-diagnosis STEP-2?

- YES >> GO TO 5.
- NO >> Malfunctioning A/C and AV switch or unified meter and A/C amp. Refer to [ATC-84. "Self-Diagnosis"](#).

5.STEP-3: MODE DOOR AND INTAKE DOOR POSITIONS ARE CHECKED

Press temperature control (UP) switch (driver side).

Does code No. 30 appear on the display?

- YES >> GO TO 6.
- NO >> GO TO 14.

Display (when all doors are in good order)

Indicates 50 seconds after "3" is indicated.

Indicates

30

SJIA1779E

6.STEP-4: OPERATION OF EACH DOOR MOTOR IS CHECKED

1. Press temperature control (UP) switch (driver side).
2. Press  (DEF) switch. Code No. of each door motor test is indicated on the display.

>> GO TO 7.

Indicates

Changes from "1" to "6"

41

SJIA1780E

7.CHECK ACTUATORS

A
B
C
D
E
F
G
H
I
ATC
K
L
M
N
O
P

TROUBLE DIAGNOSIS

< SERVICE INFORMATION >

Refer to the following chart and check discharge air flow, air temperature, blower motor duty ratio and compressor operation.

Discharge air flow			
Mode door position	Air outlet/distribution		
	Vent	Foot	Defroster
	100%	-	-
	58%	42%	-
	19% (25%)	61% (75%)	20% (-)
	14%	46%	40%
	-	-	100%

(): Manually control SJIA0302E

Code No.	41	42	43	44	45	46
Mode door position	VENT	B/L 1	B/L 2	FOOT*1	D/F	DEF
Intake door position	REC	REC	20% FRE	FRE	FRE	FRE
Air mix door position	FULL COLD	FULL COLD	FULL HOT	FULL HOT	FULL HOT	FULL HOT
Blower motor duty ratio	37%	91%	65%	65%	65%	91%
Compressor	ON	ON	OFF	OFF	ON	ON
Electronic control valve (ECV) duty ratio	100%	100%	0%	0%	50%	100%

Checks must be made visually, by listening the sound, or by touching air outlets with hand, etc. for improper operation.

*1: FOOT position during automatic control. Refer to "AUXILIARY MECHANISM: FOOT POSITION SETTING TRIMMER".

OK or NG

OK >> GO TO 8.

- NG >>
- Air outlet does not change.
Go to Mode Door Motor Circuit. Refer to [ATC-57, "Mode Door Motor Circuit"](#).
 - Intake door does not change.
Go to Intake Door Motor Circuit. Refer to [ATC-62, "Intake Door Motor Circuit"](#).
 - Discharge air temperature does not change.
Go to Air Mix Door Motor Circuit. Refer to [ATC-59, "Air Mix Door Motor Circuit"](#).
 - Blower motor operation is malfunctioning.
Go to Blower Motor Circuit. Refer to [ATC-64, "Blower Motor Circuit"](#).
 - Magnet clutch does not engage.
Go to Magnet Clutch Circuit. Refer to [ATC-69, "Magnet Clutch Circuit"](#).

8. STEP-5: TEMPERATURE OF EACH SENSOR IS CHECKED

1. Press temperature control (UP) switch (driver side).
2. Code No. 51 appears on the display.

>> GO TO 9.

9. CHECK AMBIENT SENSOR

Press (DEF) switch one time. Temperature detected by ambient sensor is indicated on the display.

NOTE:

If the temperature indicated on the display greatly differs from the actual temperature, check sensor circuit first, and then check sensor.

OK or NG

OK >> GO TO 10.

NG >> Go to Ambient Sensor Circuit. Refer to [ATC-86, "Ambient Sensor Circuit"](#).

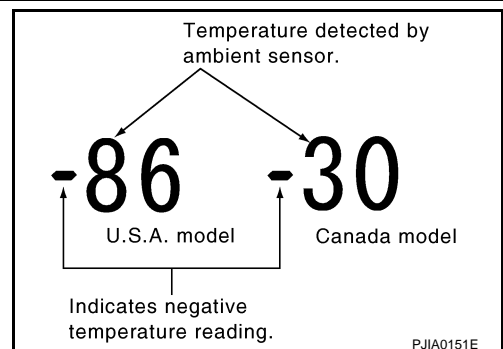

TROUBLE DIAGNOSIS

< SERVICE INFORMATION >

10. CHECK IN-VEHICLE SENSOR

Press  (DEF) switch for the second time. Temperature detected by in-vehicle sensor is indicated on the display.

NOTE:

If the temperature indicated on the display greatly differs from the actual temperature, check sensor circuit first, and then check sensor.

OK or NG

- OK >> GO TO 11.
- NG >> Go to In-vehicle Sensor Circuit. Refer to [ATC-88, "In-vehicle Sensor Circuit"](#).

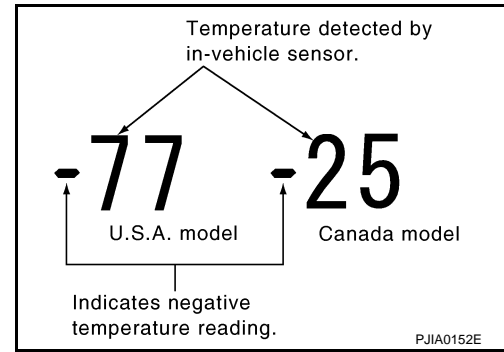

11. CHECK INTAKE SENSOR

Press  (DEF) switch for the third time. Temperature detected by intake sensor is indicated on the display.

NOTE:

If the temperature indicated on the display greatly differs from the actual temperature, check sensor circuit first, and then check sensor.

OK or NG

- OK >> GO TO 12.
- NG >> Go to Intake Sensor Circuit. Refer to [ATC-94, "Intake Sensor Circuit"](#).

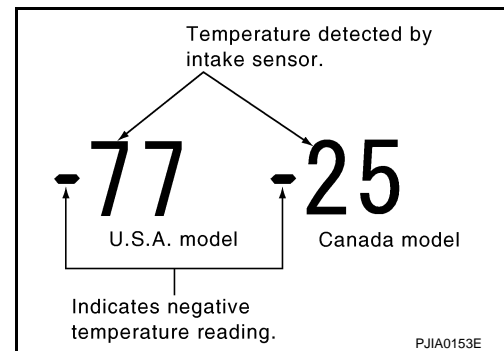



12. CHECK CAN COMMUNICATION ERROR

1. Press intake switch.
2. CAN communication error between the unified meter and A/C amp. and the display control unit can be detected as self-diagnosis results. (If plural errors occur, the display of each error will blink twice for 0.5 second intervals.)

OK or NG

- OK >> 1. Turn ignition switch OFF or AUTO switch ON.
2. INSPECTION END
- NG >> Go to CAN communication. Refer to [BCS-11, "CONSULT-III Function \(BCM\)"](#).
 - Unified meter and A/C amp. - Display control unit

Display	Multiplex communication error
52	In good order
52 	Display control unit ⇔ Unified meter and A/C amp.
52 	Unified meter and A/C amp. ⇔ Display control unit

SJJA1611E

13. CHECK MALFUNCTIONING SENSOR AND DOOR MOTOR

Refer to the following chart for malfunctioning code No.

(If two or more sensors and door motors malfunction, corresponding code Nos. indicates 1 second each.)

Code No.	Malfunctioning sensor and door motor (Including circuits)	Reference page
21 / -21	Ambient sensor	ATC-86, "Ambient Sensor Circuit"
22 / -22	In-vehicle sensor	ATC-88, "In-vehicle Sensor Circuit"
24 / -24	Intake sensor	ATC-94, "Intake Sensor Circuit"
25 / -25	Sunload sensor*1	ATC-91, "Sunload Sensor Circuit"
26 / -26	Air mix door motor PBR (Driver side)	ATC-62, "Air Mix Door Motor PBR Circuit"
27 / -27	Air mix door motor PBR (Passenger side)	

*1: Perform self-diagnosis STEP-2 under sunshine.

TROUBLE DIAGNOSIS

< SERVICE INFORMATION >

When performing indoors, aim a light (more than 60 W) at sunload sensor, otherwise code No. 25 will indicate despite that sunload sensor is functioning properly.

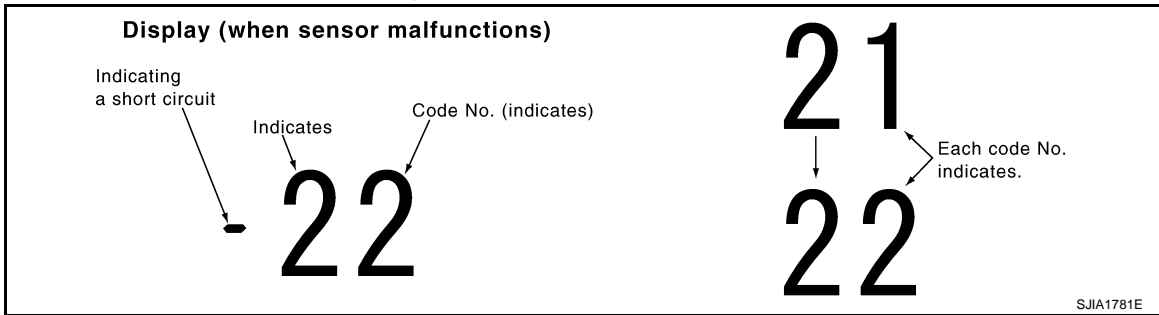

>> INSPECTION END

14. CHECK MALFUNCTIONING DOOR MOTOR POSITION SWITCH

Mode and/or intake door motor PBR(s) is/are malfunctioning.

Code No. *1 *2	Mode or intake door position	Reference page
31	VENT	ATC-57. "Mode Door Motor Circuit"
32	B/L 1	
33	B/L 2	
34	FOOT*3	
35	D/F	
36	DEF	
37	FRE	ATC-62. "Intake Door Motor Circuit"
38	20% FRE	
39	REC	

(If two or more mode or intake door motors malfunction, corresponding code Nos. indicates 1 second each.)

*1: If mode door motor harness connector is disconnected, the following display pattern will appear.

31→32→33→34→35→36→Return to 31

*2: If intake door motor harness connector is disconnected, the following display pattern will appear.

37→38→39→Return to 37

*3: FOOT position during automatic control. Refer to "AUXILIARY MECHANISM: FOOT POSITION SETTING TRIMMER".

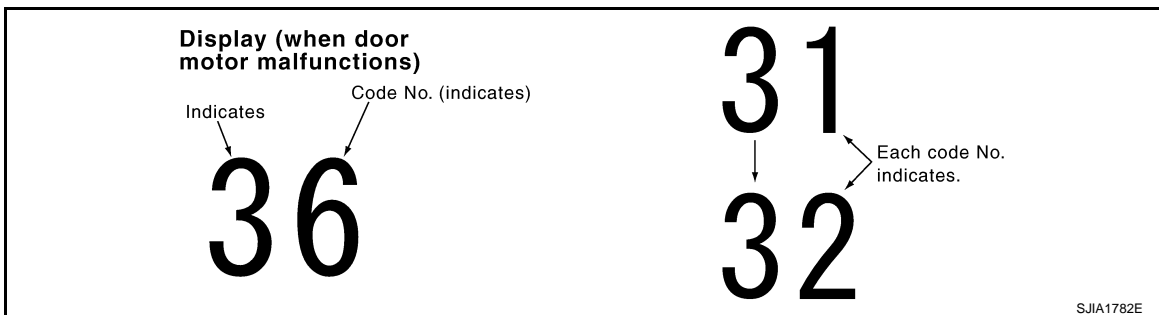

>> INSPECTION END

AUXILIARY MECHANISM: TEMPERATURE SETTING TRIMMER

The trimmer compensates for differences in range of $\pm 3^{\circ}\text{C}$ ($\pm 6^{\circ}\text{F}$) between temperature setting (displayed digitally) and temperature felt by customer.

Operating procedures for this trimmer are as follows:

1. Begin self-diagnosis STEP-5 mode. Refer to "Self-diagnosis Function".
2. Press (fan) UP switch to set system in auxiliary mode.
3. Display shows "61" in auxiliary mechanism. It takes approximately 3 seconds to enable setting operation.

TROUBLE DIAGNOSIS

< SERVICE INFORMATION >

- Press temperature control switch (driver side) as desired. Temperature will change at a rate of 0.5°C (1.0°F) each time a switch is pressed.

CAUTION:

A decimal point is not indicated on the display.

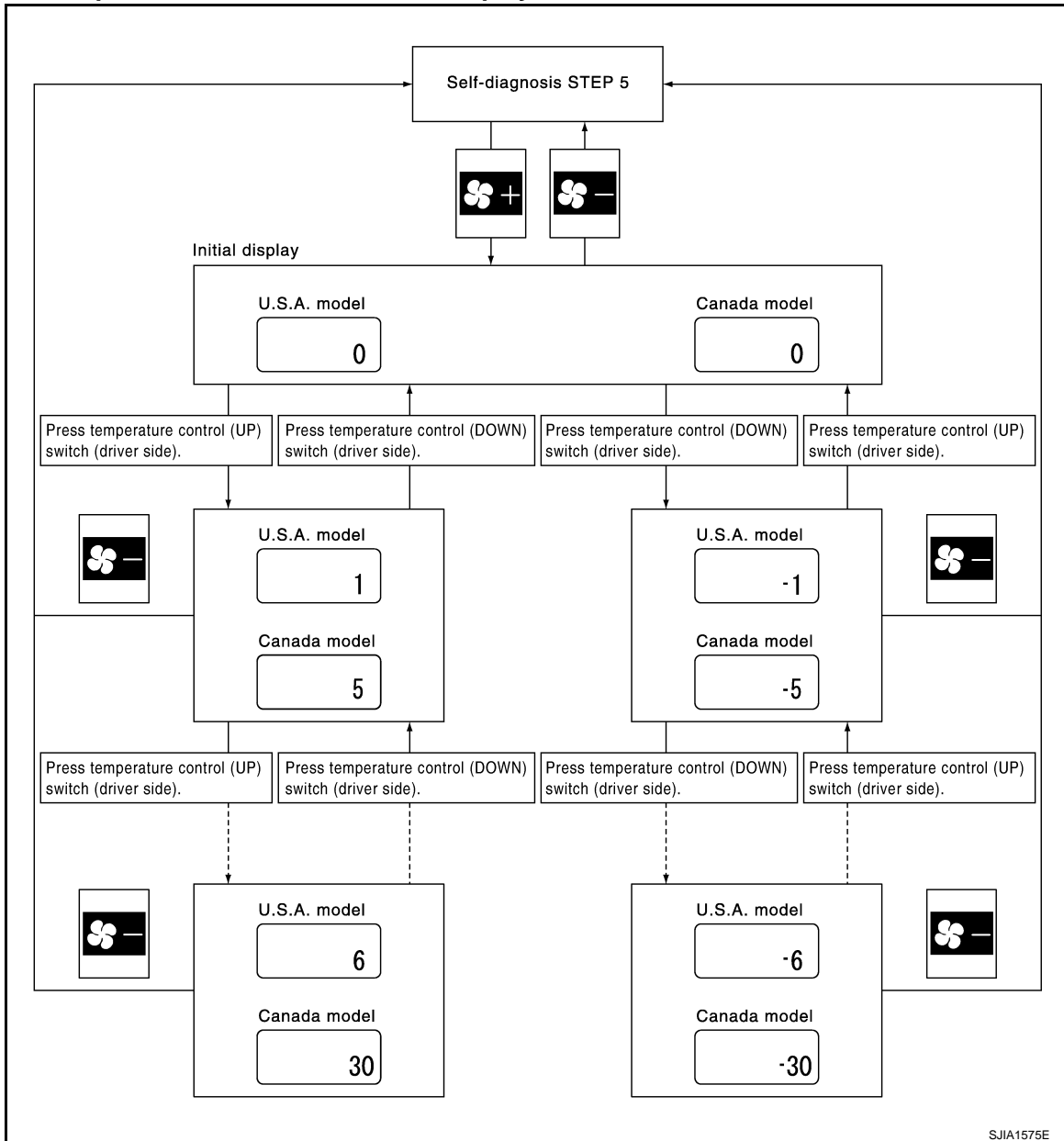

When battery cable is disconnected or battery voltage is below 10 V, trimmer operation is canceled. Temperature set becomes that of initial condition, i.e. 0°C (0°F).

AUXILIARY MECHANISM: FOOT POSITION SETTING TRIMMER

Wind distribution ratio in FOOT mode can be set.



Operating procedures for this trimmer are as follows:

- Begin self-diagnosis STEP-5 mode. Refer to "Self-diagnosis Function".
- Press ⚙️ (fan) UP switch to set system in auxiliary mode.
- Display shows "61" in auxiliary mechanism. It takes approximately 3 seconds to enable setting operation.

TROUBLE DIAGNOSIS

< SERVICE INFORMATION >

4. Press the mode switch as desired.

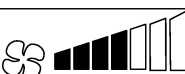
Display	Discharge air flow					
	Automatically controls the mode door			Manually controls the mode door		
	VENT	FOOT	DEF	VENT	FOOT	DEF
 (Initial setting)	19%	61%	20%	25%	75%	—
	19%	61%	20%	19%	61%	20%
	25%	75%	—	19%	61%	20%
	25%	75%	—	25%	75%	—

SJIA1581E

When battery cable is disconnected or battery voltage is below 10 V, trimmer operation is canceled. Wind distribution ratio set becomes that of initial condition.

AUXILIARY MECHANISM: INLET PORT MEMORY FUNCTION

When ignition switch is turned from OFF to ON, inlet port memory function at manual mode can be set.

Operating procedures for this trimmer are as follows:

1. Begin self-diagnosis STEP-5 mode. Refer to "Self-diagnosis Function".
2. Press  (fan) UP switch to set system in auxiliary mode.
3. Press the intake switch as desired.

LED status of FRE position	LED status of REC position	Setting status		Setting changeover method
		FRE	REC	
OFF	OFF	AUTO control	AUTO control	Intake SW: ON
OFF	ON	AUTO control (Initial setting)	Manual REC status is memorized. (Initial setting)	
ON	OFF	Manual FRE status is memorized.	AUTO control	
ON	ON	Manual FRE status is memorized.	Manual REC status is memorized.	

When battery cable is disconnected or battery voltage is below 10 V, memory function is canceled. Memory function set becomes that of initial condition.

Operational Check

INFOID:000000001328182

The purpose of the operational check is to check if the individual system operates properly.

Conditions : Engine running at normal operating temperature

CHECKING MEMORY FUNCTION

1. Press the temperature control (UP) switch (driver side) until 32°C (90°F) is displayed.
2. Press OFF switch.
3. Turn ignition switch OFF.
4. Turn ignition switch ON.
5. Press the AUTO switch.
6. Confirm that the set temperature remains at previous temperature.
7. Press OFF switch.

If NG, go to trouble diagnosis procedure for [ATC-85. "Memory Function"](#).

If OK, continue the check.

CHECKING BLOWER

TROUBLE DIAGNOSIS

< SERVICE INFORMATION >

1. Press fan (UP:+) switch. Blower should operate on low speed. The fan symbol should have one blade lit.
2. Press fan (UP:+) switch again, and continue checking blower speed and fan symbol until all speeds are checked.
3. Leave blower on max. speed.

If NG, go to trouble diagnosis procedure for [ATC-64. "Blower Motor Circuit"](#).

If OK, continue the check.

CHECKING DISCHARGE AIR

1. Press MODE switch and DEF switch.
2. Each position indicator should change shape.
3. Confirm that discharge air comes out according to the air distribution table. Refer to [ATC-29. "Discharge Air Flow"](#).

If NG, go to trouble diagnosis procedure for [ATC-57. "Mode Door Motor Circuit"](#).

If OK, continue the check.

NOTE:

Confirm that the compressor clutch is engaged (sound or visual inspection) and intake door position is at FRE when the D/F or DEF is selected.

Discharge air flow			
Mode door position	Air outlet/distribution		
	Vent	Foot	Defroster
	100%	-	-
	58%	42%	-
	19% (25%)	61% (75%)	20% (-)
	14%	46%	40%
	-	-	100%

(): Manually control SJIA0302E

CHECKING INTAKE AIR

1. Press intake switch. Recirculation indicator should illuminate.
2. Press intake switch again. Fresh indicator should illuminate.
3. Listen for intake door position change. (Slight change of blower sound can be heard.)

If NG, go to trouble diagnosis procedure for [ATC-62. "Intake Door Motor Circuit"](#).

If OK, continue the check.

NOTE:

Confirm that the compressor clutch is engaged (sound or visual inspection) and intake door position is at FRE when the D/F or DEF is selected.

CHECKING TEMPERATURE DECREASE

1. Press temperature control (DOWN) switch (driver side) until 18°C (60°F) is displayed.
2. Check for cold air at discharge air outlets.

If NG, go to trouble diagnosis procedure for [ATC-75. "Insufficient Cooling"](#).

If OK, continue the check.

CHECKING TEMPERATURE INCREASE

1. Press temperature control (UP) switch (driver side) until 32°C (90°F) is displayed.
2. Check for hot air at discharge air outlets.

If NG, go to trouble diagnosis procedure for [ATC-82. "Insufficient Heating"](#).

If OK, continue the check.

CHECKING A/C SWITCH

1. Press AUTO switch and A/C switch.
2. A/C switch indicator will turn ON.
 - Confirm that the compressor clutch engages (sound or visual inspection).

If NG, go to trouble diagnosis procedure for [ATC-69. "Magnet Clutch Circuit"](#).

If OK, continue the check.

CHECKING AUTO MODE

1. Press AUTO switch and A/C switch.
2. Display should indicate AUTO.
 - Confirm that discharge air and blower speed will depend on ambient, in-vehicle, and set temperatures.

If NG, go to trouble diagnosis procedure for [ATC-52. "Power Supply and Ground Circuit for Auto Amp"](#), then if necessary, trouble diagnosis procedure for [ATC-69. "Magnet Clutch Circuit"](#).

TROUBLE DIAGNOSIS

< SERVICE INFORMATION >

If all operational checks are OK (symptom cannot be duplicated), go to Incident Simulation Tests in [GI-25, "How to Perform Efficient Diagnosis for an Electrical Incident"](#) and perform tests as outlined to simulate driving conditions environment. If symptom appears, refer to [ATC-32, "How to Perform Trouble Diagnosis for Quick and Accurate Repair"](#) and perform applicable trouble diagnosis procedures.

Power Supply and Ground Circuit for Auto Amp

INFOID:000000001328183

SYMPTOM: A/C system does not activate.

INSPECTION FLOW

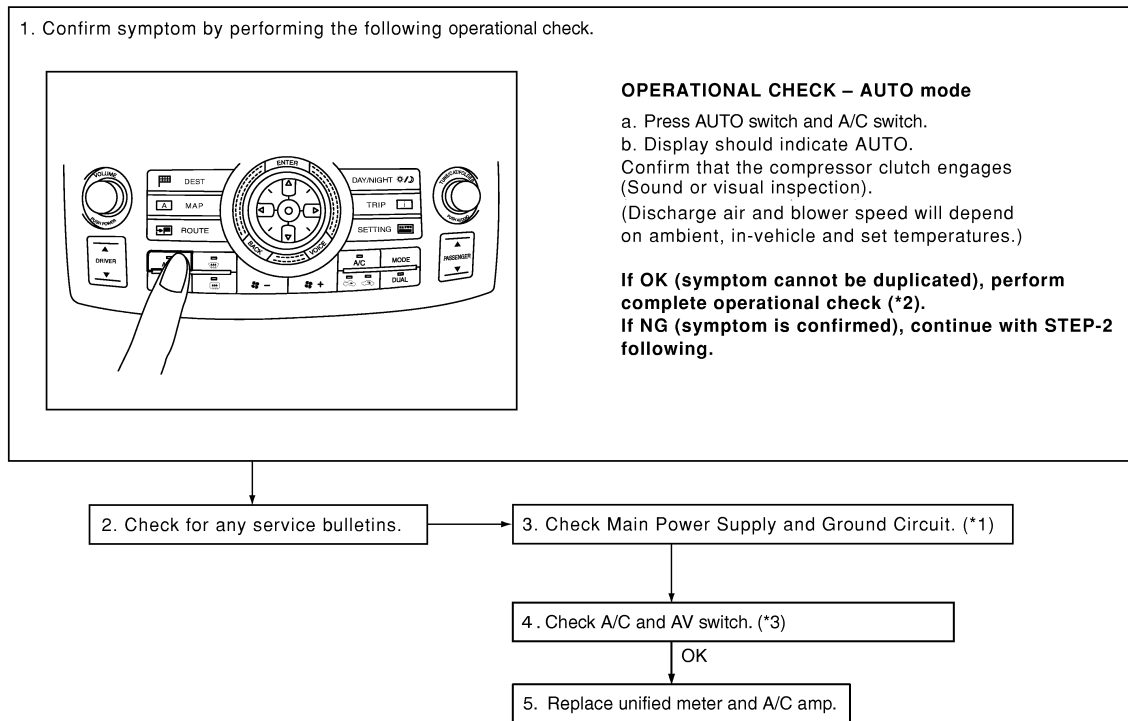

SJA1582E

*1 "DIAGNOSIS PROCEDURE FOR A/C SYSTEM"

*2 [ATC-50, "Operational Check"](#)

*3 [AV-79, "Unable to Operate System with A/C and AV Switch"](#) (Without navigation system) or [AV-127, "Unable to Operate System with A/C and AV Switch"](#) (With navigation system)

COMPONENT DESCRIPTION

Unified Meter and A/C Amp. (Automatic Amplifier)

The unified meter and A/C amp. has a built-in microcomputer which processes information sent from various sensors needed for air conditioner operation. The air mix door motor, mode door motor, intake door motor, blower motor and compressor are then controlled.

When the various switches and temperature control switch are operated, data is input to the unified meter and A/C amp. from the display control unit using CAN communication.

Self-diagnosis functions are also built into unified meter and A/C amp. to provide quick check of malfunctions in the auto air conditioner system.

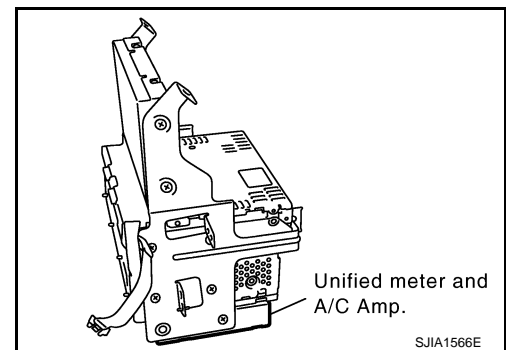

Potential Temperature Control (PTC)

TROUBLE DIAGNOSIS

< SERVICE INFORMATION >

The PTC is built into the A/C and AV switch. It can be set at an interval of 0.5°C (1.0°F) in the 18°C (60°F) to 32°C (90°F) temperature range by pressing temperature control switch. The set temperature is displayed.

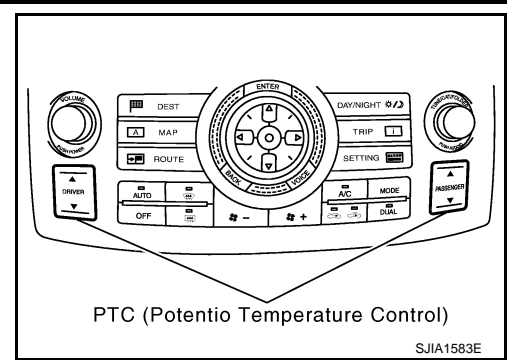

DIAGNOSIS PROCEDURE FOR A/C SYSTEM

SYMPTOM: A/C system does not activate.

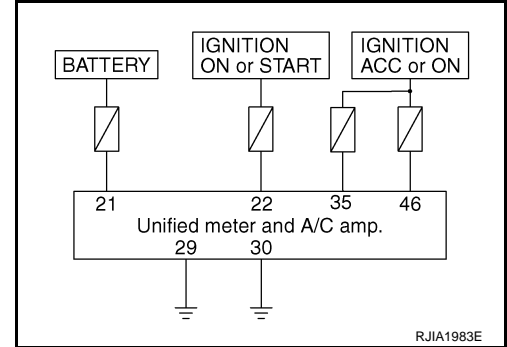

1. CHECK POWER SUPPLY CIRCUIT FOR UNIFIED METER AND A/C AMP.

1. Disconnect unified meter and A/C amp. connector.
2. Check voltage between unified meter and A/C amp. harness connector M56 terminals 21, 22 and 35, unified meter and A/C amp. harness connector M57 terminal 46 and ground.

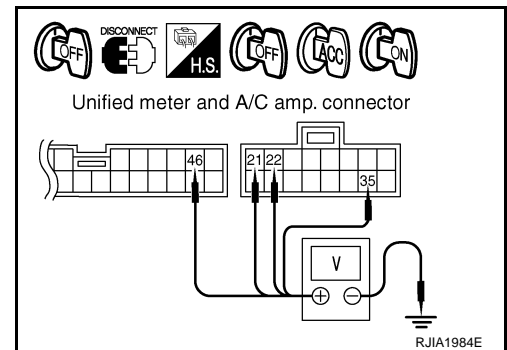

Terminals		Ignition switch position			
(+)		(-)	OFF	ACC	ON
Unified meter and A/C amp. connector	Terminal No.				
M56	21	Ground	Battery voltage	Battery voltage	Battery voltage
M56	22		Approx. 0 V	Approx. 0 V	Battery voltage
M56	35		Approx. 0 V	Battery voltage	Battery voltage
M57	46		Approx. 0 V	Battery voltage	Battery voltage

OK or NG

OK >> GO TO 2.

NG >> Check 10A and 15A fuses [Nos. 6, 10, 11, 12 and 19, located in the fuse block (J/B)]. Refer to [PG-77](#).

- If fuses are OK, check harness for open circuit. Repair or replace if necessary.
- If fuses are NG, check harness for short circuit and replace fuse.

2. CHECK GROUND CIRCUIT FOR UNIFIED METER AND A/C AMP.

1. Turn ignition switch OFF.

TROUBLE DIAGNOSIS

< SERVICE INFORMATION >

- Check continuity between unified meter and A/C amp. harness connector M56 terminal 29, 30 and ground.

29, 30 – Ground : Continuity should exist.

OK or NG

- OK >> Replace unified meter and A/C amp.
 NG >> Repair harness or connector.

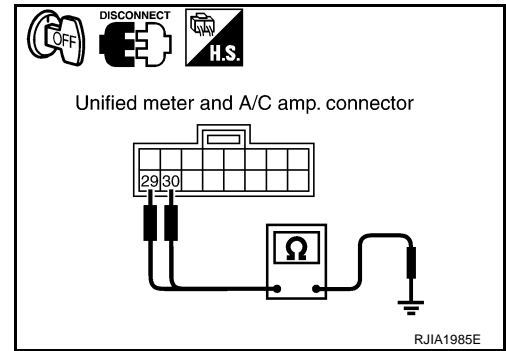

LAN System Circuit

INFOID:000000001328184

SYMPTOM: Mode door motor, intake door motor and/or air mix door motor(s) does not operate normally.

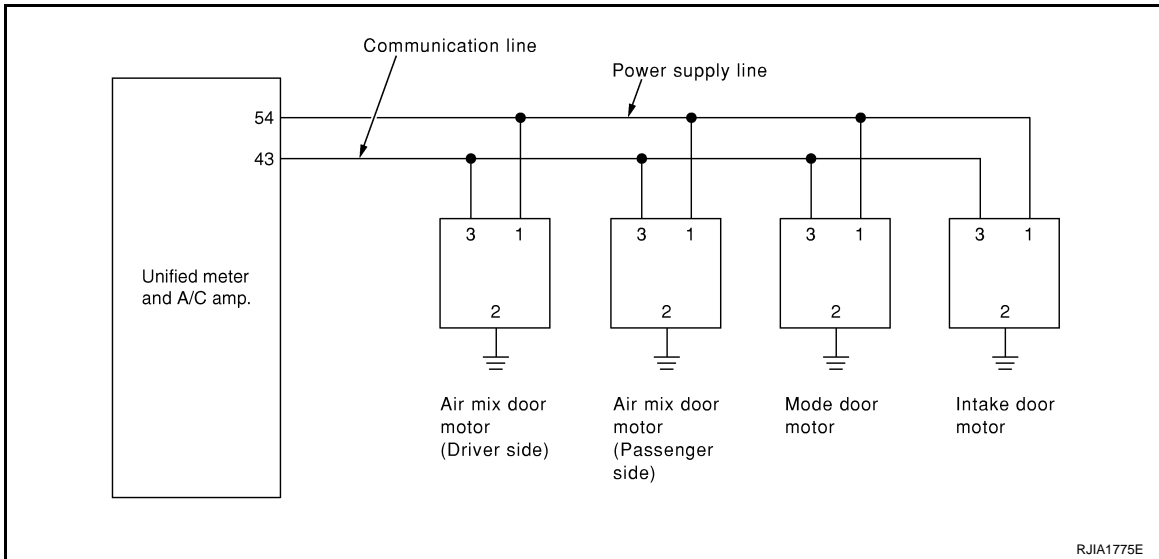

DIAGNOSIS PROCEDURE FOR LAN CIRCUIT

1. CHECK POWER SUPPLY FOR UNIFIED METER AND A/C AMP.

- Turn ignition switch ON.
- Check voltage between unified meter and A/C amp. harness connector M57 terminal 54 and ground.

54 – Ground : Battery voltage

OK or NG

- OK >> GO TO 2.
 NG >> Replace unified meter and A/C amp.

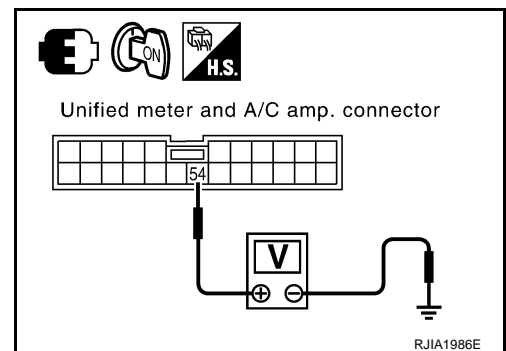

2. CHECK SIGNAL FOR UNIFIED METER AND A/C AMP.

TROUBLE DIAGNOSIS

< SERVICE INFORMATION >

Confirm A/C LAN signal between unified meter and A/C amp. harness connector M57 terminal 43 and ground using an oscilloscope.

Terminals		Voltage
(+)		
Unified meter and A/C amp. connector	Terminal No.	(-)
M57	43	Ground

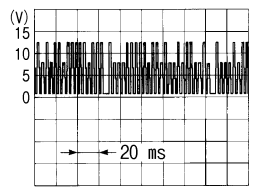

SJA1453J

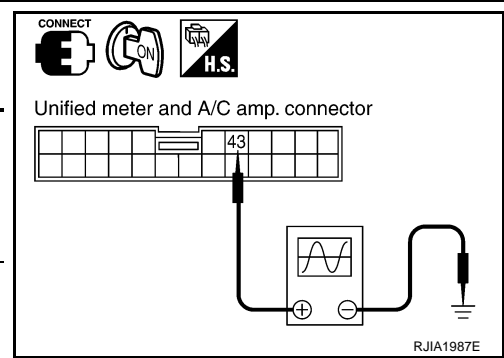

OK or NG

OK >> GO TO 3.

NG >> Replace unified meter and A/C amp.

3.CHECK POWER SUPPLY FOR EACH DOOR MOTOR

Check voltage between each door motor harness connector terminal 1 and ground.

1 – Ground : Battery voltage

OK or NG

OK >> GO TO 4.

NG >> Repair harness or connector.

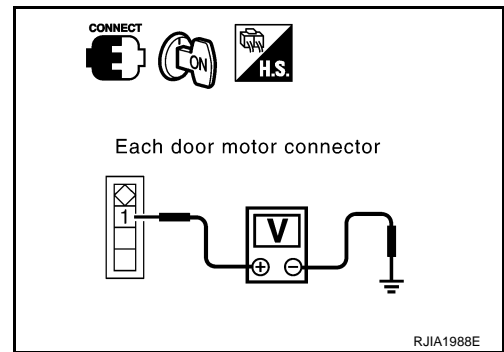

4.CHECK SIGNAL FOR EACH DOOR MOTOR

Confirm A/C LAN signal between each door motor harness connector terminal 3 and ground using an oscilloscope.

Door motor	Terminals		Voltage
	(+)		
	Con-connector	Terminal No.	
Mode	M258	3	Ground
Air mix (Driver side)	M252	3	
Air mix (Passenger side)	M257	3	
Intake	M253	3	

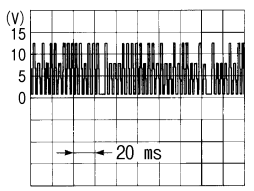

SJA1453J

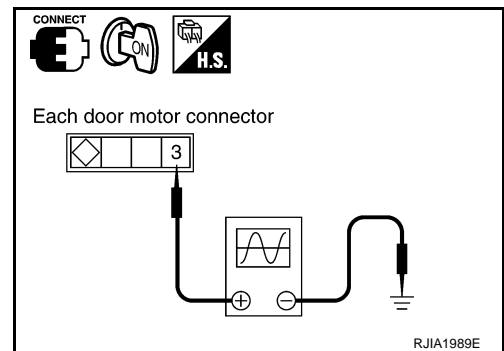

OK or NG

OK >> GO TO 5.

NG >> Repair harness or connector.

5.CHECK MOTOR GROUND CIRCUIT

1. Turn ignition switch OFF.
2. Disconnect each door motor connector.

A
B
C
D
E
F
G
H
I
K
L
M
N
O
P

ATC

TROUBLE DIAGNOSIS

< SERVICE INFORMATION >

3. Check continuity between each door motor harness connector terminal 2 and ground.

2 – Ground : Continuity should exist.

OK or NG

- OK >> GO TO 6.
NG >> Repair harness or connector.

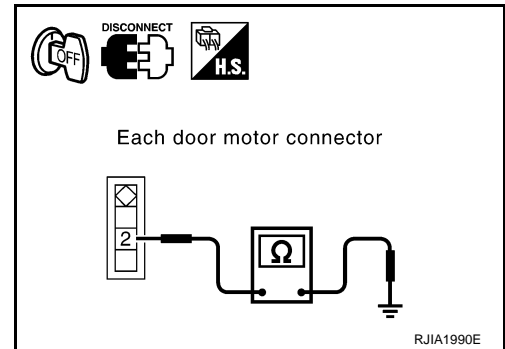

6. CHECK MOTOR OPERATION

1. Reconnect each door motor connector.
2. Turn ignition switch ON.
3. Confirm operation of each door motor.

OK or NG

- OK >> (Return to operate normally.)
• Poor contact in motor connector.
NG >> (Does not operate normally.)
• GO TO 7.

7. CHECK AIR MIX DOOR MOTOR AND INTAKE DOOR MOTOR OPERATION

1. Turn ignition switch OFF.
2. Disconnect mode, air mix (driver side, passenger side), and intake door motor connectors.
3. Reconnect air mix (driver side, passenger side) and intake door motor connectors.
4. Turn ignition switch ON.
5. Confirm operation of air mix door motor (driver side, passenger side) and intake door motor.

OK or NG

- OK >> [Air mix (driver side, passenger side) and intake door motors operate normally.]
• Replace mode door motor.
NG >> [Air mix (driver side, passenger side) and intake door motors does not operate normally.]
• GO TO 8.

8. CHECK MODE DOOR MOTOR AND INTAKE DOOR MOTOR OPERATION

1. Turn ignition switch OFF.
2. Disconnect air mix door motor (driver side, passenger side) connectors.
3. Reconnect mode door motor connector.
4. Turn ignition switch ON.
5. Confirm operation of mode door motor and intake door motor.

OK or NG

- OK >> (Mode and intake door motors operate normally.)
• GO TO 10.
NG >> (Mode and intake door motors does not operate normally.)
• GO TO 9.

9. CHECK MODE DOOR MOTOR AND AIR MIX DOOR MOTOR OPERATION

1. Turn ignition switch OFF.
2. Disconnect intake door motor connector.
3. Reconnect air mix door motor (driver side, passenger side) connectors.
4. Turn ignition switch ON.
5. Confirm operation of mode door motor and air mix door motor (driver side, passenger side).

OK or NG

- OK >> [Mode and air mix door motor (driver side, passenger side) operate normally.]
• Replace intake door motor.
NG >> [Mode and air mix door motor (driver side, passenger side) does not operate normally.]
• Replace display and A/C auto amp.

10. CHECK AIR MIX DOOR MOTOR OPERATION

TROUBLE DIAGNOSIS

< SERVICE INFORMATION >

1. Turn ignition switch OFF.
2. Disconnect air mix door motor (driver side) connector.
3. Turn ignition switch ON.
4. Confirm operation of air mix door motor (passenger side).

OK or NG

- OK >> [Air mix door motor (passenger side) operates normally.]
- Replace air mix door motor (driver side).
- NG >> [Air mix door motor (passenger side) does not operate normally.]
- Replace air mix door motor (passenger side).

Mode Door Motor Circuit

INFOID:000000001328185

SYMPTOM

- Air outlet does not change.
- Mode door motor does not operate normally.

INSPECTION FLOW

1. Confirm symptom by performing the following operational check.

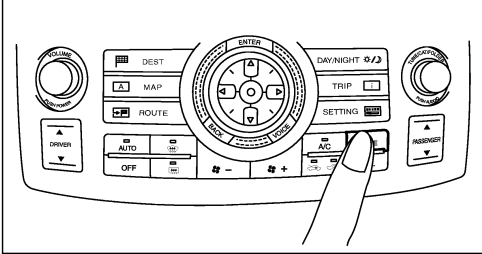

OPERATIONAL CHECK – Discharge air

- a. Press MODE switch and DEF switch.
- b. Each position indicator should change shape.

Discharge air flow

Mode door position	Air outlet/distribution		
	Vent	Foot	Defroster
	100%	–	–
	58%	42%	–
	19%(25%)	61%(75%)	20%(–)
	14%	46%	40%
	–	–	100%

() : Manually control

- c. Confirm that discharge air comes out according to the air distribution table at left.
Refer to "Discharge Air Flow" (*1).

NOTE:

- If OK (symptom cannot be duplicated), perform complete operational check (*2).
- If NG (symptom is confirmed), continue with STEP-2 following.
- Confirm that the compressor clutch is engaged (sound or visual inspection) and intake door position is at FRE when DEF or D/F is selected.

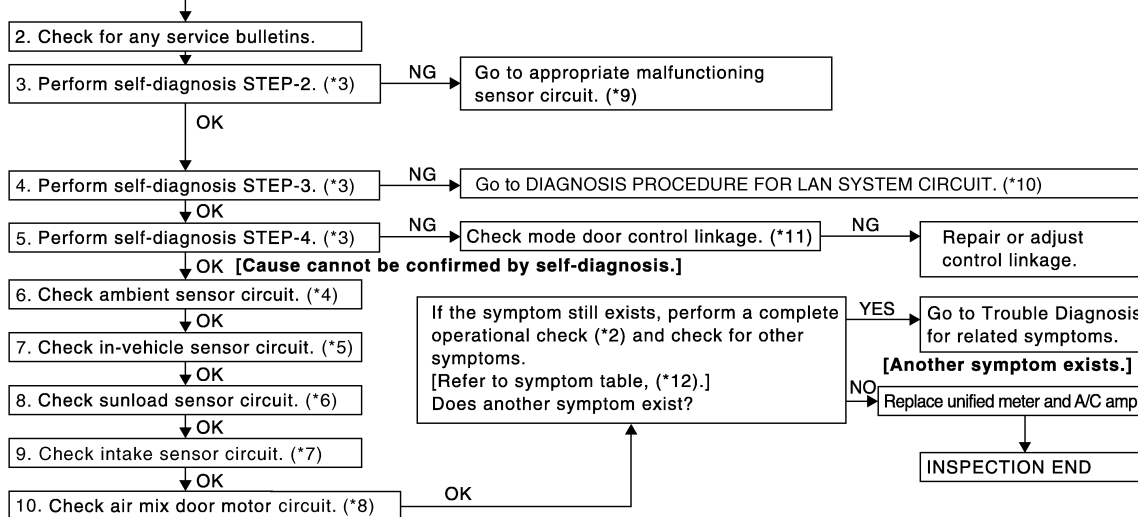

SJIA1806E

TROUBLE DIAGNOSIS

< SERVICE INFORMATION >

- | | | |
|---|---|--|
| *1 ATC-29, "Discharge Air Flow" | *2 ATC-50, "Operational Check" | *3 ATC-43, "Self-Diagnosis Function", see No. 4 to 6. |
| *4 ATC-86, "Ambient Sensor Circuit" | *5 ATC-88, "In-vehicle Sensor Circuit" | *6 ATC-91, "Sunload Sensor Circuit" |
| *7 ATC-94, "Intake Sensor Circuit" | *8 ATC-59, "Air Mix Door Motor Circuit" | *9 ATC-43, "Self-Diagnosis Function", see No. 13. |
| *10 ATC-54, "LAN System Circuit" | *11 ATC-113 | *12 ATC-32, "How to Perform Trouble Diagnosis for Quick and Accurate Repair" |

SYSTEM DESCRIPTION

Component Parts

Mode door control system components are:

- Unified meter and A/C amp.
- Mode door motor (LCU)
- A/C LAN system (PBR built-in mode door motor, air mix door motor and intake door motor)
- In-vehicle sensor
- Ambient sensor
- Sunload sensor
- Intake sensor

System Operation

The unified meter and A/C amp. receives data from each of the sensors. The unified meter and A/C amp. sends air mix door, mode door and intake door opening angle data to the air mix door motor LCUs, mode door motor LCU and intake door motor LCU.

The air mix door motors, mode door motor and intake door motor read their respective signals according to the address signal. Opening angle indication signals received from the unified meter and A/C amp. and each of the motor position sensors are compared by the LCUs in each door motor with the existing decision and opening angles. Subsequently, HOT/COLD, DEF/VENT and FRE/REC operation is selected. The new selection data are returned to the unified meter and A/C amp.

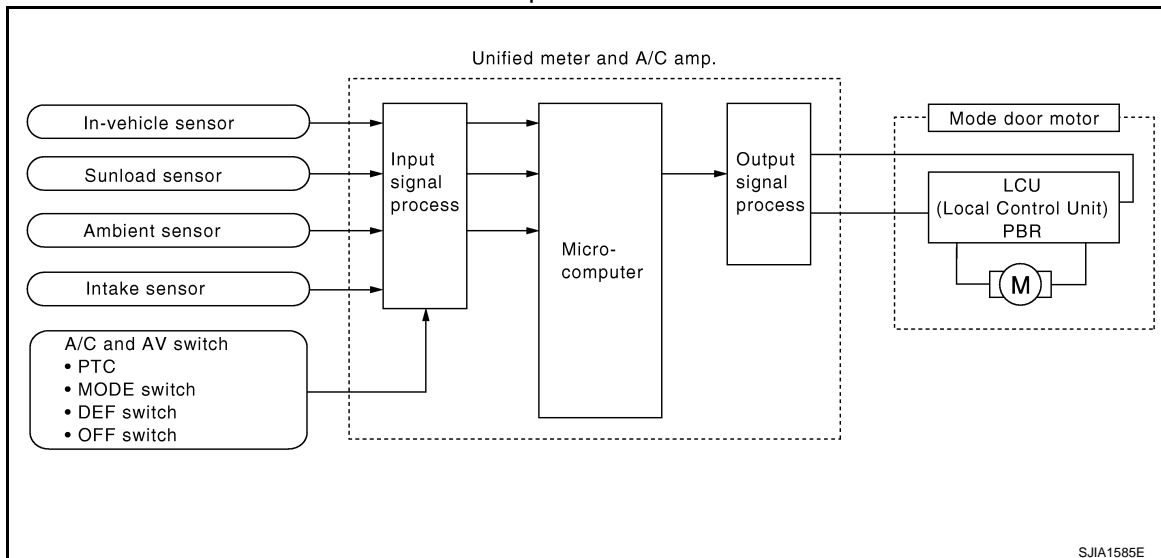

Mode Door Control Specification

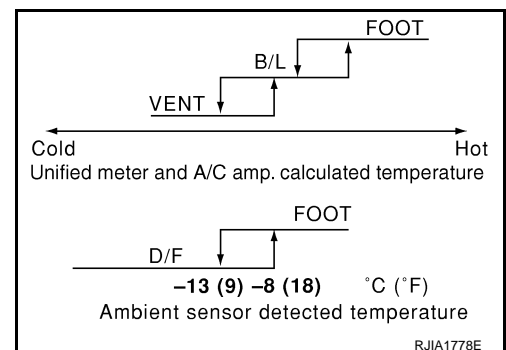

TROUBLE DIAGNOSIS

< SERVICE INFORMATION >

COMPONENT DESCRIPTION

Mode Door Motor

The mode door motor is attached to the heater & cooling unit assembly. It rotates so that air is discharged from the outlet set by the unified meter and A/C amp. Motor rotation is conveyed to a link which activates the mode door.

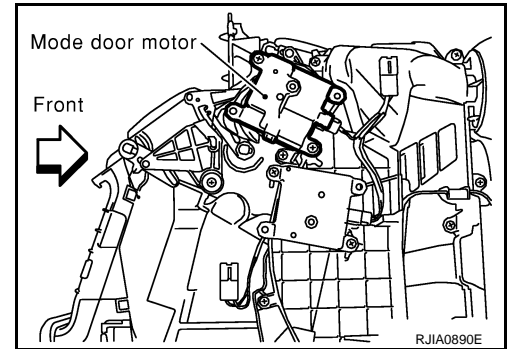

DIAGNOSIS PROCEDURE FOR MODE DOOR MOTOR

SYMPTOM: Mode door motor does not operate normally.

Perform diagnosis procedure. Refer to [ATC-54, "LAN System Circuit"](#).

Air Mix Door Motor Circuit

INFOID:000000001328186

SYMPTOM

- Discharge air temperature does not change.
- Air mix door motor does not operate normally.

INSPECTION FLOW

A
B
C
D
E
F
G
H
I
K
L
M
N
O
P

ATC

TROUBLE DIAGNOSIS

< SERVICE INFORMATION >

1. Confirm symptom by performing the following operational check.

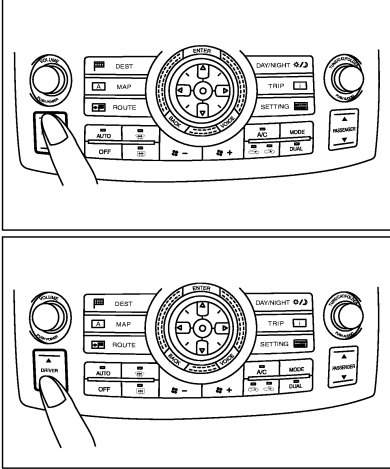

OPERATIONAL CHECK

Temperature increase

- Press temperature control (UP) switch (driver side) until 32°C (90°F) is displayed.
- Check for hot air at discharge air outlets.

Temperature decrease

- Press temperature control (DOWN) switch (driver side) until 18°C (60°F) is displayed.
- Check for cold air at discharge air outlets.

If OK (symptom cannot be duplicated), perform complete operational check (*8).
If NG (symptom is confirmed), continue with STEP-2 following.

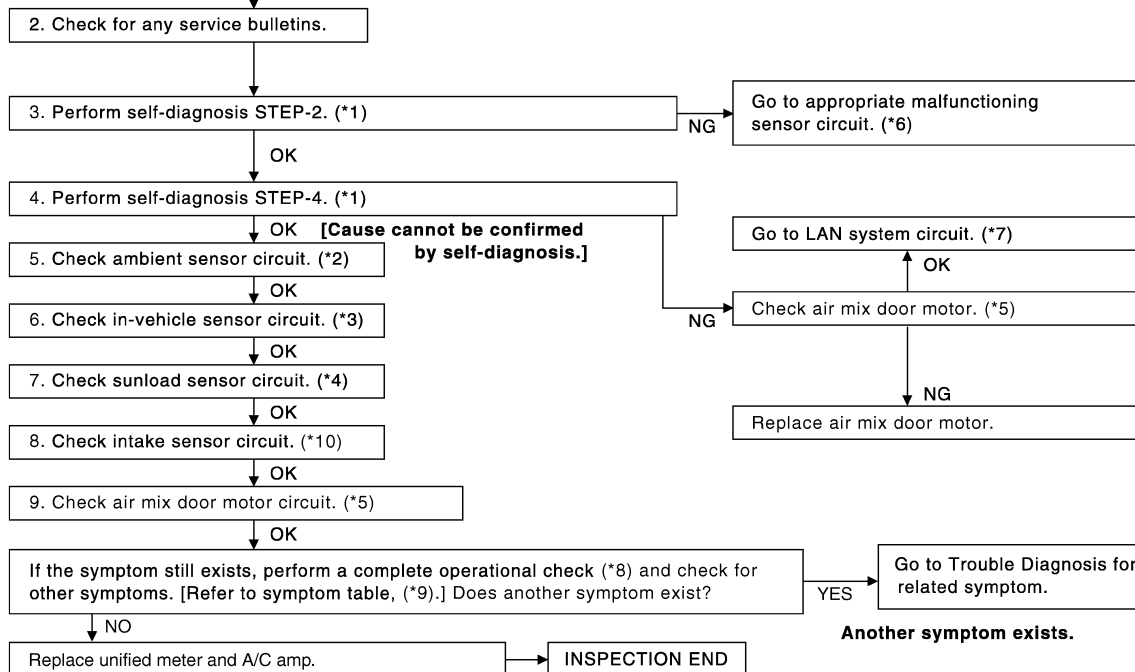

SJIA1586E

*1 [ATC-43. "Self-Diagnosis Function"](#), see No. 4 to 6.

*2 [ATC-86. "Ambient Sensor Circuit"](#)

*3 [ATC-88. "In-vehicle Sensor Circuit"](#)

*4 [ATC-91. "Sunload Sensor Circuit"](#)

*5 [ATC-62. "Air Mix Door Motor PBR Circuit"](#)

*6 [ATC-43. "Self-Diagnosis Function"](#), see No. 13.

*7 [ATC-54. "LAN System Circuit"](#).

*8 [ATC-50. "Operational Check"](#)

*9 [ATC-32. "How to Perform Trouble Diagnosis for Quick and Accurate Repair"](#)

*10 [ATC-94. "Intake Sensor Circuit"](#)

SYSTEM DESCRIPTION

Component Parts

Air mix door control system components are:

- Unified meter and A/C amp.
- Air mix door motor (LCU)
- A/C LAN system (PBR built-in mode door motor, air mix door motor and intake door motor)
- In-vehicle sensor
- Ambient sensor

TROUBLE DIAGNOSIS

< SERVICE INFORMATION >

- Sunload sensor
- Intake sensor

System Operation

The unified meter and A/C amp. receives data from each of the sensors. The unified meter and A/C amp. sends air mix door, mode door and intake door motor opening angle data to the air mix door motor LCUs, mode door motor LCU and intake door motor LCU.

The air mix door motors, mode door motor and intake door motor read their respective signals according to the address signal. Opening angle indication signals received from the unified meter and A/C amp. and each of the motor position sensors are compared by the LCUs in each door motor with the existing decision and opening angles. Subsequently, HOT/COLD, DEF/VENT and FRE/REC operation is selected. The new selection data are returned to the unified meter and A/C amp.

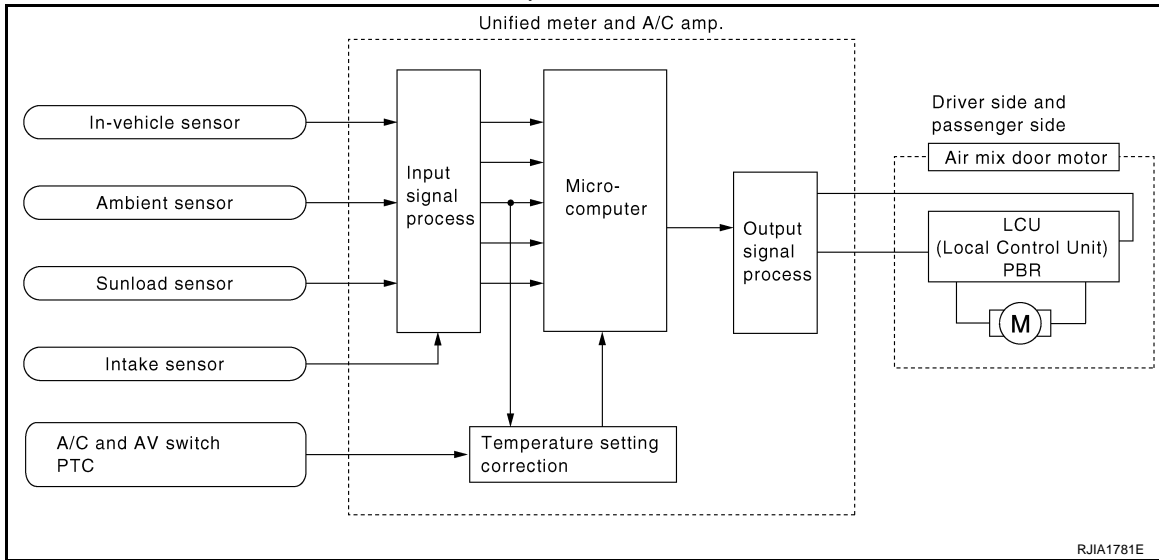

Air Mix Door Control Specification

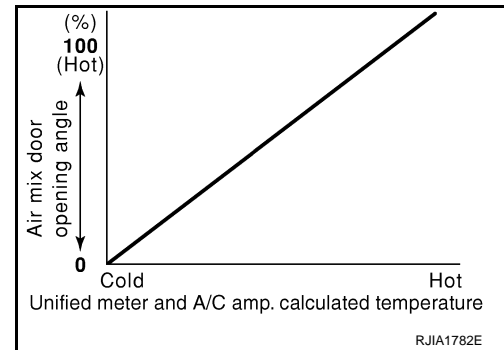

COMPONENT DESCRIPTION

Air Mix Door Motor

The air mix door motors are attached to the heater & cooling unit assembly. It rotates so that the air mix door is opened or closed to a position set by the unified meter and A/C amp. Motor rotation is then conveyed through a shaft and the air mix door position feedback is then sent to the unified meter and A/C amp. by PBR built-in air mix door motor.

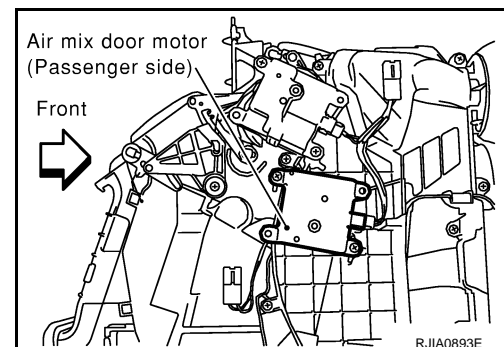

TROUBLE DIAGNOSIS

< SERVICE INFORMATION >

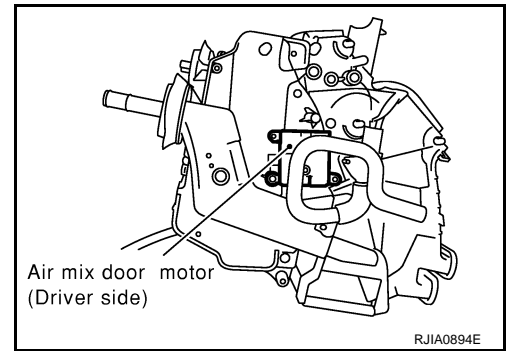

DIAGNOSIS PROCEDURE FOR AIR MIX DOOR MOTOR

SYMPTOM: Discharge air temperature does not change.

Perform diagnosis procedure. Refer to [ATC-54, "LAN System Circuit"](#).

Air Mix Door Motor PBR Circuit

INFOID:000000001328187

SYMPTOM

- Discharge air temperature does not change.
- PBR circuit is open or shorted.

DIAGNOSIS PROCEDURE FOR AIR MIX DOOR MOTOR PBR

Perform diagnosis procedure. Refer to [ATC-54, "LAN System Circuit"](#).

Intake Door Motor Circuit

INFOID:000000001328188

SYMPTOM

- Intake door does not change.
- Intake door motor does not operate normally.

INSPECTION FLOW

TROUBLE DIAGNOSIS

< SERVICE INFORMATION >

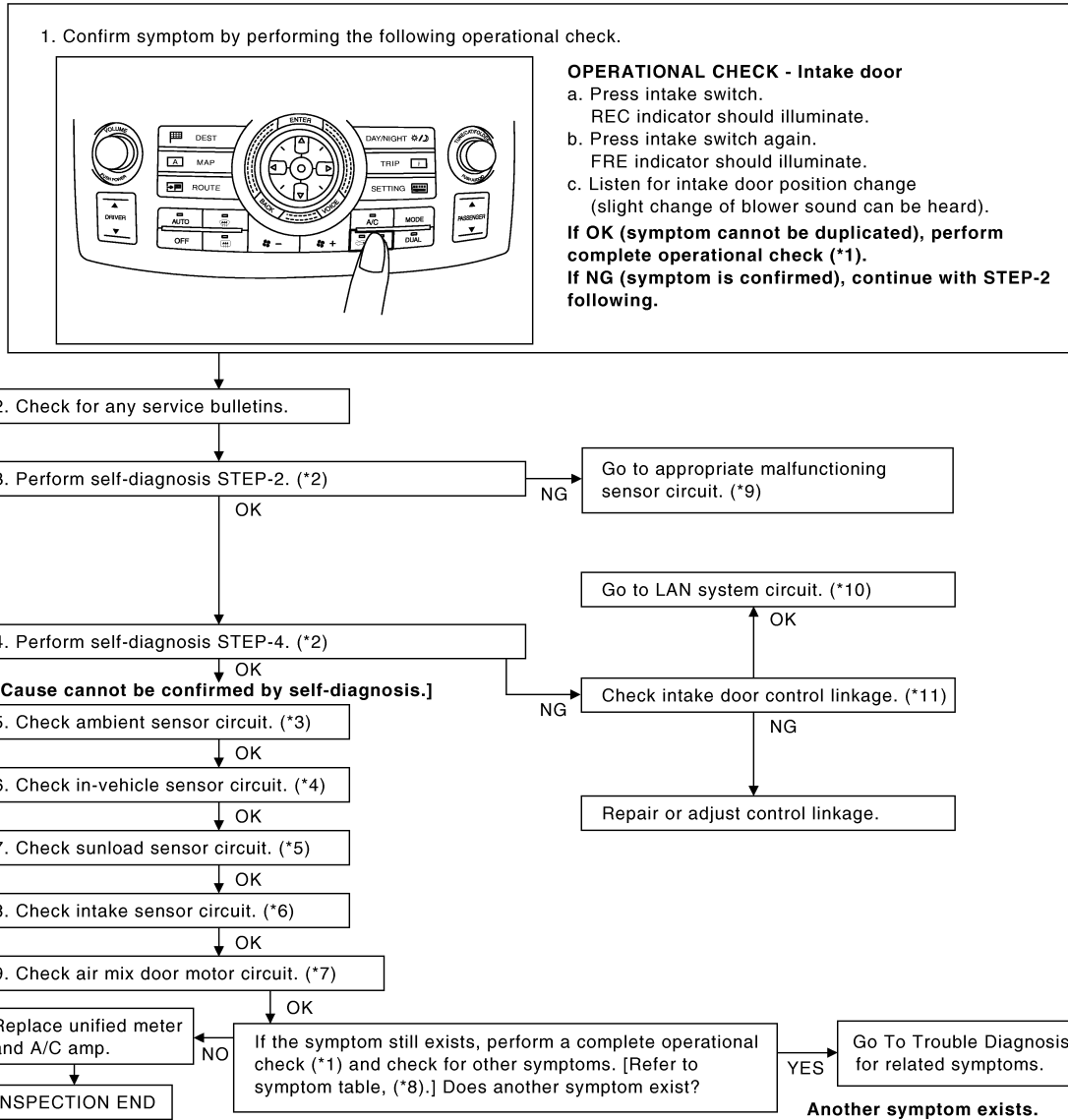

SJIA1807E

- *1 [ATC-50. "Operational Check"](#)
- *2 [ATC-43. "Self-Diagnosis Function"](#), see No. 4 to 6.
- *3 [ATC-86. "Ambient Sensor Circuit"](#)
- *4 [ATC-88. "In-vehicle Sensor Circuit"](#)
- *5 [ATC-91. "Sunload Sensor Circuit"](#)
- *6 [ATC-94. "Intake Sensor Circuit"](#)
- *7 [ATC-59. "Air Mix Door Motor Circuit"](#)
- *8 [ATC-32. "How to Perform Trouble Diagnosis for Quick and Accurate Repair"](#)
- *9 [ATC-43. "Self-Diagnosis Function"](#), see No. 13.
- *10 [ATC-54. "LAN System Circuit"](#)
- *11 [ATC-106](#)

SYSTEM DESCRIPTION

Component Parts

Intake door control system components are:

- Unified meter and A/C amp.
- Intake door motor (LCU)
- A/C LAN system (PBR built-in mode door motor, air mix door motor and intake door motor)
- In-vehicle sensor
- Ambient sensor
- Sunload sensor

TROUBLE DIAGNOSIS

< SERVICE INFORMATION >

• Intake sensor

System Operation

The intake door control determines intake door position based on the ambient temperature, the intake air temperature and the in-vehicle temperature. When the DEF, or OFF switches are pressed or A/C switch is OFF, the unified meter and A/C amp. sets the intake door at the FRE position.

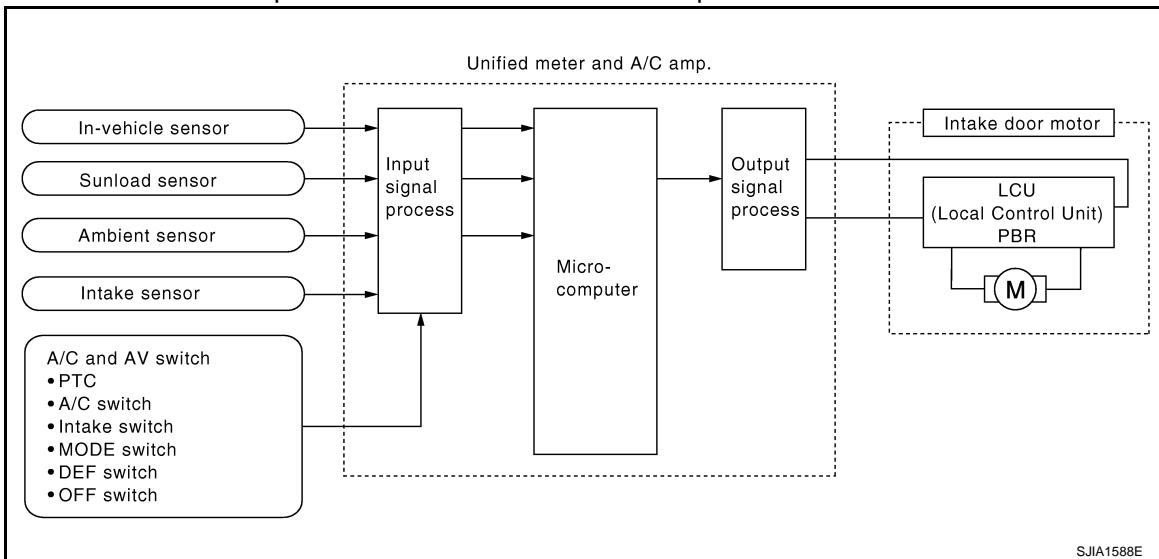

Intake Door Control Specification

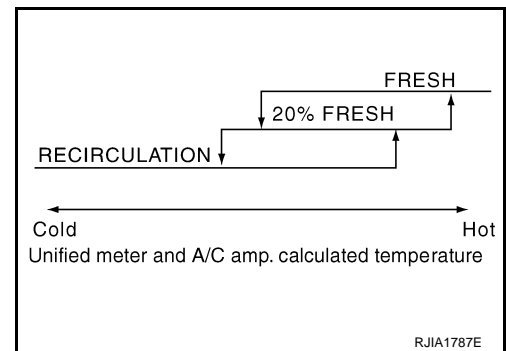

COMPONENT DESCRIPTION

Intake Door Motor

The intake door motor is attached to the blower unit. It rotates so that air is drawn from inlets set by the unified meter and A/C amp. Motor rotation is conveyed to a lever which activates the intake door.

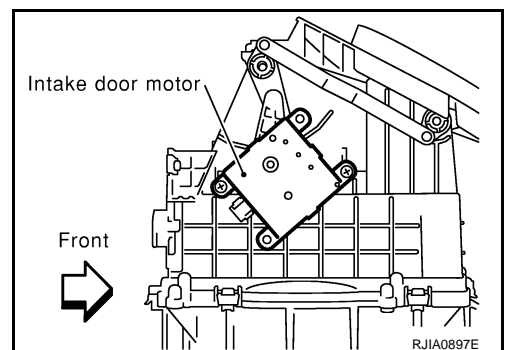

DIAGNOSIS PROCEDURE FOR INTAKE DOOR MOTOR

SYMPTOM: Intake door motor does not operate normally.

Perform diagnosis procedure. Refer to [ATC-54, "LAN System Circuit"](#).

Blower Motor Circuit

INFOID:000000001328189

SYMPTOM: Blower motor operation is malfunctioning.

INSPECTION FLOW

TROUBLE DIAGNOSIS

< SERVICE INFORMATION >

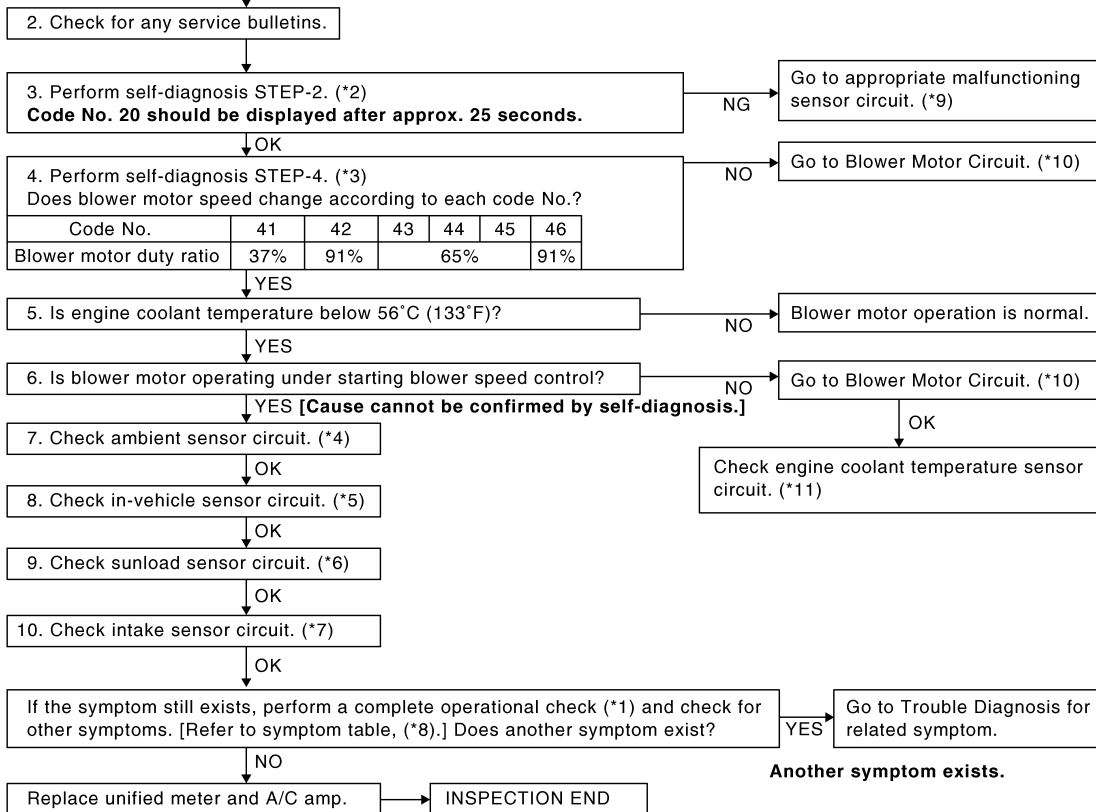
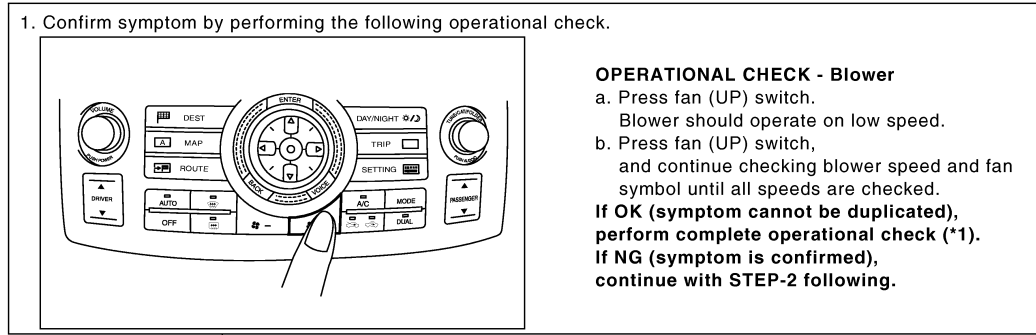

SJIA1808E

*1 [ATC-50. "Operational Check"](#)

*2 [ATC-43. "Self-Diagnosis Function"](#), see No. 4.

*3 [ATC-43. "Self-Diagnosis Function"](#), see No. 6.

*4 [ATC-86. "Ambient Sensor Circuit"](#)

*5 [ATC-88. "In-vehicle Sensor Circuit"](#)

*6 [ATC-91. "Sunload Sensor Circuit"](#)

*7 [ATC-94. "Intake Sensor Circuit"](#)

*8 [ATC-32. "How to Perform Trouble Diagnosis for Quick and Accurate Repair"](#)

*9 [ATC-43. "Self-Diagnosis Function"](#), see No. 13.

*10 "DIAGNOSIS PROCEDURE FOR BLOWER MOTOR"

*11 [EC-193 \(VQ35DE\)](#) or [EC-779 \(VK45DE\)](#)

SYSTEM DESCRIPTION

Component Parts

Fan speed control system components are:

- Unified meter and A/C amp.
- A/C LAN system (PBR built-in mode door motor, air mix door motor and intake door motor)
- In-vehicle sensor
- Ambient sensor
- Sunload sensor

TROUBLE DIAGNOSIS

< SERVICE INFORMATION >

- Intake sensor

System Operation

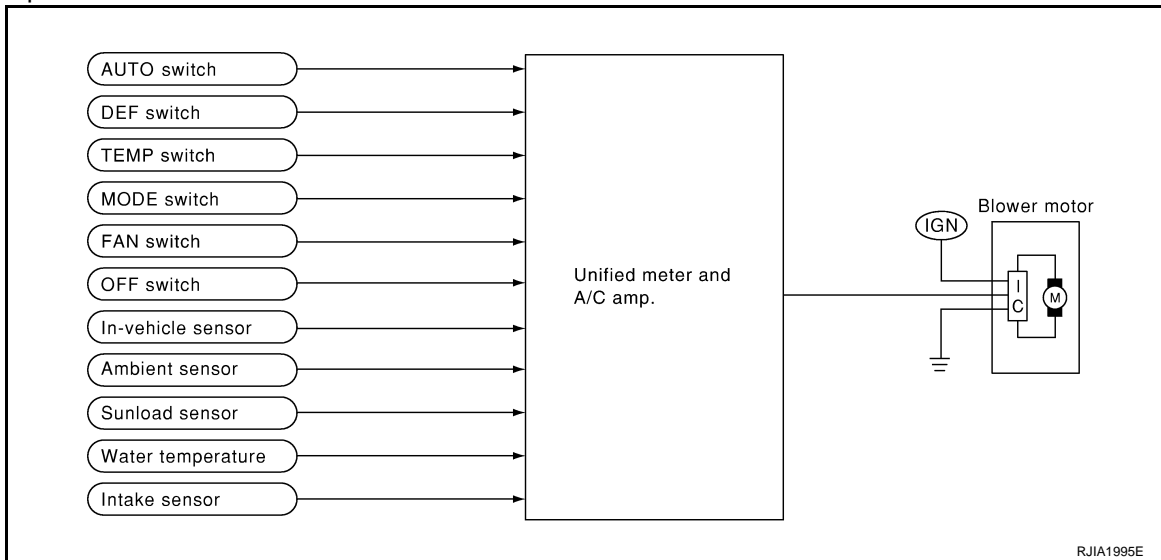

Automatic Mode

In the automatic mode, the blower motor speed is calculated by the unified meter and A/C amp. based on the input from the PBR, in-vehicle sensor, sunload sensor, intake sensor and ambient sensor.

When the air flow is increased, the duty ratio of the blower fan motor's drive signal is changed at 8%/sec. to prevent a sudden increase in air flow.

In addition to manual air flow control and the usual automatic air flow control, starting air flow control, low water temperature starting control and high passenger compartment temperature starting control are available.

Starting Fan Speed Control

Start up from COLD SOAK Condition (Automatic mode)

In a cold start up condition where the engine coolant temperature is below 56°C (133°F), the blower will not operate for a short period of time (up to 150 seconds). The exact start delay time varies depending on the ambient and engine coolant temperature.

In the most extreme case (very low ambient) the blower starting delay will be 150 seconds as described above. After this delay, the blower will operate at low speed until the engine coolant temperature rises above 56°C (133°F), and then the blower speed will increase to the objective speed.

Start up from usual or HOT SOAK Condition (Automatic mode)

The blower will begin operation momentarily after the AUTO switch is pressed. The blower speed will gradually rise to the objective speed over a time period of 3 seconds or less (actual time depends on the objective blower speed).

Blower Speed Compensation

Sunload

When the in-vehicle temperature and the set temperature are very close, the blower will be operating at low speed. The low speed will vary depending on the sunload. During conditions of low or no sunload, the blower speed is at duty ratio 25%. During high sunload conditions, the unified meter and A/C amp. raise the blower speed (duty ratio 49%).

Fan Speed Control Specification

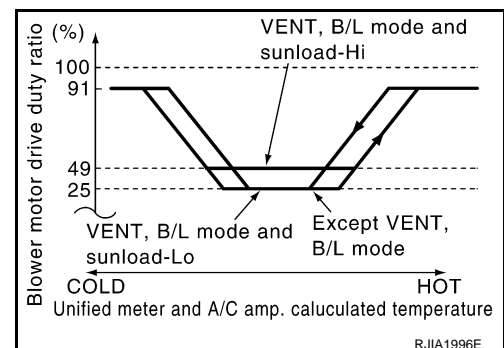

TROUBLE DIAGNOSIS

< SERVICE INFORMATION >

COMPONENT DESCRIPTION

Brush-Less Motor

The blower motor utilizes a brush-less motor with a rotating magnet. Quietness is improved over previous motors where the brush was the point of contact and the coil rotated.

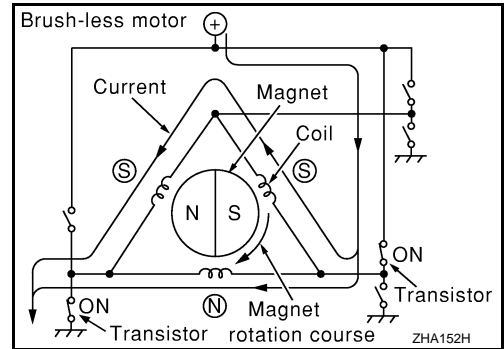

DIAGNOSIS PROCEDURE FOR BLOWER MOTOR

SYMPTOM: Blower motor operation is malfunctioning.

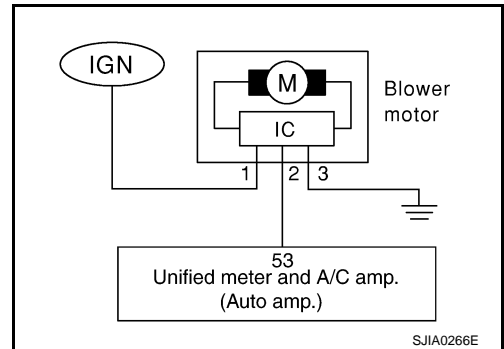

1. CHECK POWER SUPPLY FOR BLOWER MOTOR

1. Disconnect blower motor connector.
2. Turn ignition switch ON.
3. Check voltage between blower motor harness connector M78 terminal 1 and ground.

1 – Ground : Battery voltage

OK or NG

- OK >> GO TO 2.
 NG >> Check power supply circuit and 15A fuses [Nos. 10 and 11, located in the fuse block (J/B)]. Refer to [PG-77](#).
- If fuses are OK, check harness for open circuit. Repair or replace if necessary.
 - If fuses are NG, check harness for short circuit and replace fuse.

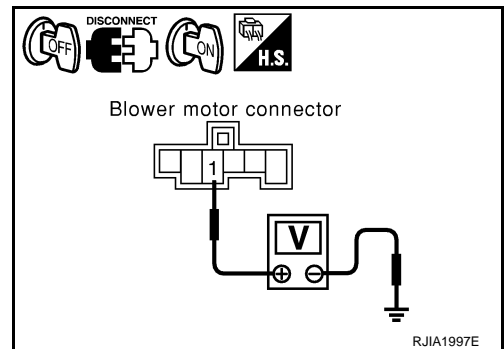

2. CHECK BLOWER MOTOR GROUND CIRCUIT

1. Turn ignition switch OFF.
2. Check continuity between blower motor harness connector M78 terminal 3 and ground.

3 – Ground : Continuity should exist.

OK or NG

- OK >> GO TO 3.
 NG >> Repair harness or connector.

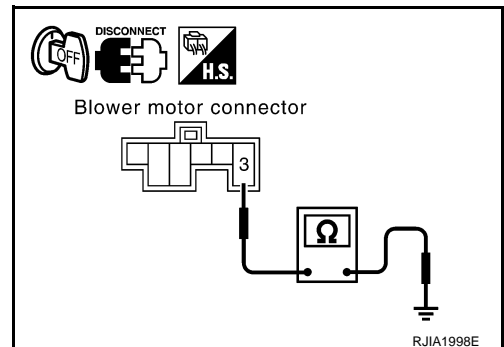

3. CHECK CIRCUIT CONTINUITY BETWEEN BLOWER MOTOR AND UNIFIED METER AND A/C AMP.

1. Disconnect unified meter and A/C amp. connector.

TROUBLE DIAGNOSIS

< SERVICE INFORMATION >

- Check continuity between blower motor harness connector M78 terminal 2 and unified meter and A/C amp. harness connector M57 terminal 53.

2 – 53

: Continuity should exist.

OK or NG

- OK >> GO TO 4.
- NG >> Repair harness or connector.

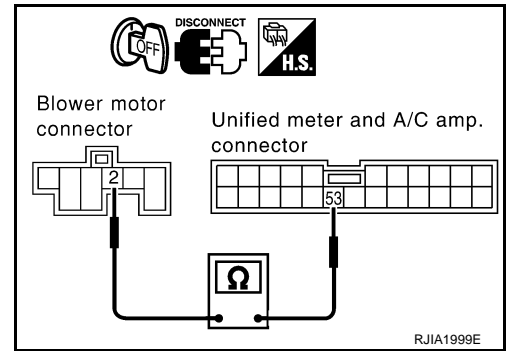

4. CHECK UNIFIED METER AND A/C AMP. OUTPUT SIGNAL

- Reconnect blower motor connector and unified meter and A/C amp. connector.
- Turn ignition switch ON.
- Change the fan speed from Lo to Hi, and check the duty ratios between blower motor harness connector M78 terminal 2 and ground using an oscilloscope. Normal terminal 2 drive signal duty ratios are shown in the table below.

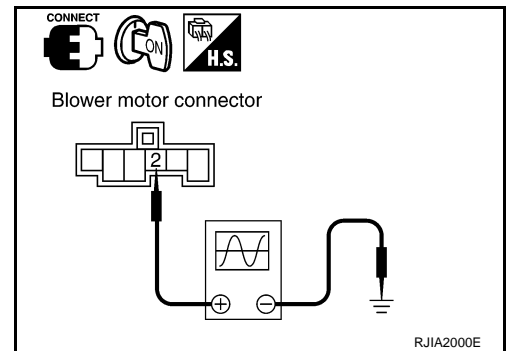

Blower fan speed (Manual)	1st	2nd	3rd	4th	5th	6th	7th
Blower motor connector M78 terminal No. 2 (Oscilloscope)							
	Approx. 1.6 ms	Approx. 1.6 ms	Approx. 1.6 ms	Approx. 1.6 ms	Approx. 1.6 ms	Approx. 1.6 ms	Approx. 1.6 ms
Duty ratio	Approx. 25%	Approx. 35%	Approx. 47%	Approx. 59%	Approx. 69%	Approx. 79%	Approx. 91%

NOTE: Duty ratio = $\frac{T_x}{\text{Approx. } 1.6 \text{ ms}} \times 100 (\%)$

SJIA1802E

OK or NG

- OK >> Replace blower motor after confirming the fan air flow does not change.
- NG >> Replace unified meter and A/C amp.

COMPONENT INSPECTION

Blower Motor

TROUBLE DIAGNOSIS

< SERVICE INFORMATION >

Confirm smooth rotation of the blower motor.

- Ensure that there are no foreign particles inside the blower unit.

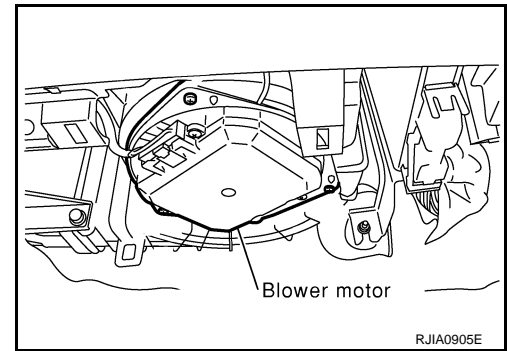

INFOID:000000001328190

Magnet Clutch Circuit

SYMPTOM: Magnet clutch does not engage.

INSPECTION FLOW

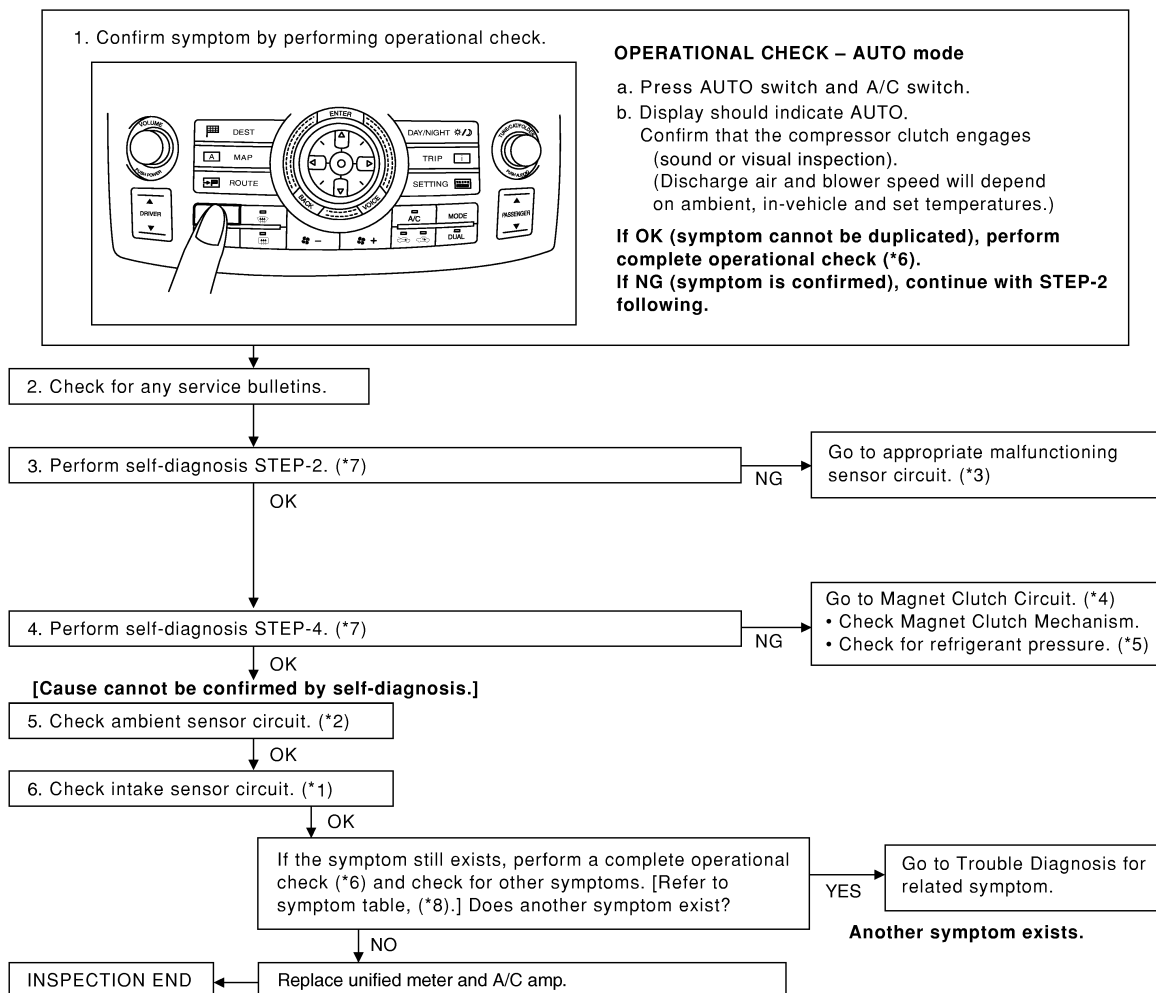

SJIA1590E

*1 [ATC-94, "Intake Sensor Circuit"](#)

*2 [ATC-86, "Ambient Sensor Circuit"](#)

*3 [ATC-43, "Self-Diagnosis Function"](#), see No. 13.

TROUBLE DIAGNOSIS

< SERVICE INFORMATION >

*4 "DIAGNOSIS PROCEDURE FOR MAGNET CLUTCH"

*7 [ATC-43. "Self-Diagnosis Function"](#), see No. 4 to 6.

*5 [ATC-75. "Insufficient Cooling"](#)

*8 [ATC-32. "How to Perform Trouble Diagnosis for Quick and Accurate Repair"](#)

*6 [ATC-50. "Operational Check"](#)

SYSTEM DESCRIPTION

Unified meter and A/C amp. controls compressor operation by ambient temperature, intake air temperature and signal from ECM.

Low Temperature Protection Control

Unified meter and A/C amp. will turn the compressor ON or OFF as determined by a signal detected by ambient sensor and intake sensor.

When ambient temperature is higher than -2°C (28°F), the compressor turns ON. The compressor turns OFF when ambient temperature is lower than -5°C (23°F).

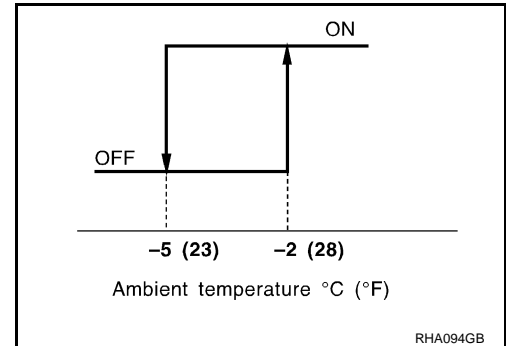

When intake air temperature is higher than 1°C (34°F), the compressor turns ON. The compressor turns OFF when intake air temperature is lower than -5°C (23°F).

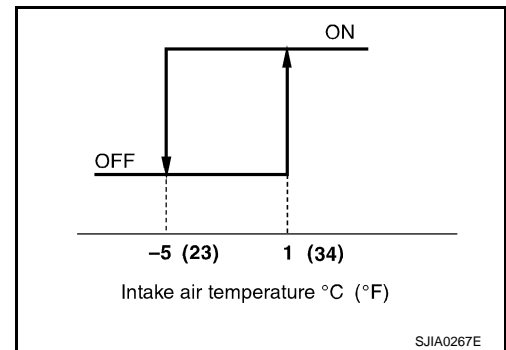

DIAGNOSIS PROCEDURE FOR MAGNET CLUTCH

SYMPTOM: Magnet clutch does not engage when A/C switch is ON.

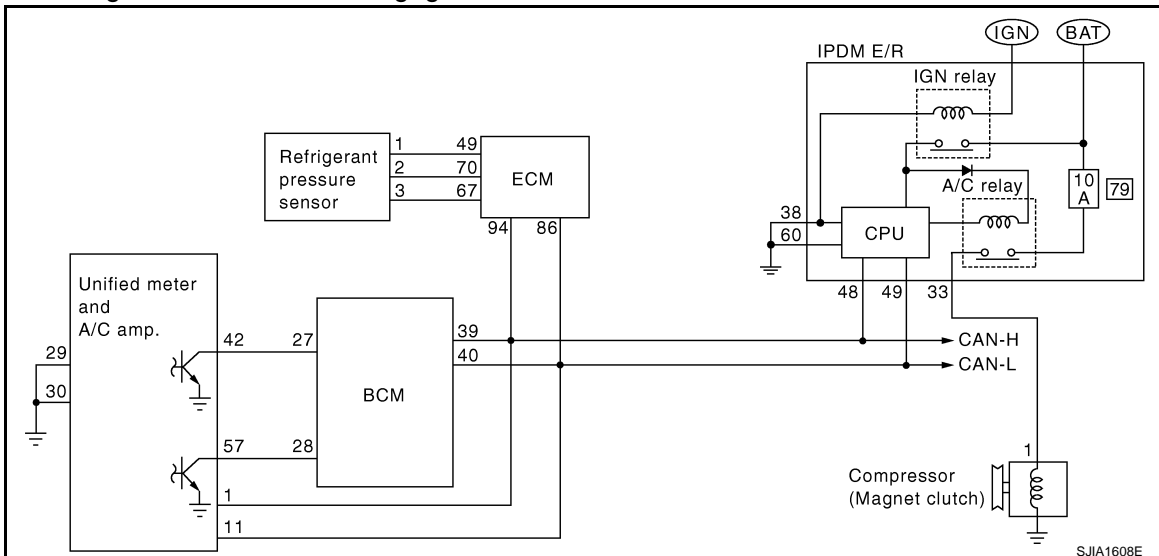

1. CHECK AMBIENT SENSOR AND INTAKE SENSOR CIRCUIT

Check ambient sensor and intake sensor. Refer to [ATC-43. "Self-Diagnosis Function"](#), see No. 9 and 11.

TROUBLE DIAGNOSIS

< SERVICE INFORMATION >



OK or NG

- OK >> GO TO 2.
NG >> • Malfunctioning ambient sensor: Refer to [ATC-86, "Ambient Sensor Circuit"](#).
• Malfunctioning intake sensor: Refer to [ATC-94, "Intake Sensor Circuit"](#).

2.PERFORM IPDM E/R AUTO ACTIVE TEST

Perform "IPDM E/R auto active test". Refer to [PG-20, "Auto Active Test"](#).

Does the magnet clutch operate?

- YES >> •  WITH CONSULT-III: GO TO 5
•  WITHOUT CONSULT-III: GO TO 6.
NO >> Check 10A fuse (No. 79, located in IPDM E/R). Refer to [PG-23, "IPDM E/R Terminal Arrangement"](#), and GO TO 3.

3.CHECK CIRCUIT CONTINUITY BETWEEN IPDM E/R AND COMPRESSOR

1. Turn ignition switch OFF.
2. Disconnect IPDM E/R connector and compressor connector.
3. Check continuity between IPDM E/R harness connector E8 terminal 33 and compressor harness connector F2 terminal 1.

33 – 1 : Continuity should exist.

OK or NG

- OK >> GO TO 4.
NG >> Repair harness or connector.

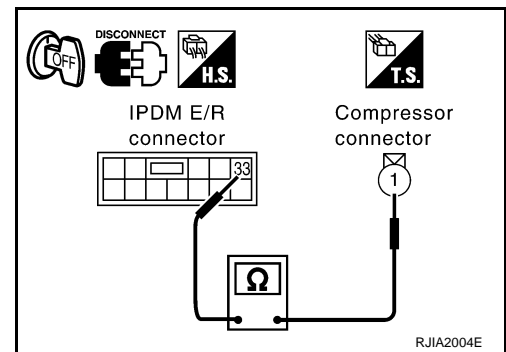

4.CHECK MAGNET CLUTCH CIRCUIT

Check for operation sound when applying battery voltage direct current to terminal.

OK or NG

- OK >> 1. Replace IPDM E/R.
2. Go to self-diagnosis procedure [ATC-43, "Self-Diagnosis Function"](#) and perform self-diagnosis STEP-4. Confirm that magnet clutch operation normal.
NG >> 1. Replace magnet clutch.
2. Go to self-diagnosis procedure [ATC-43, "Self-Diagnosis Function"](#) and perform self-diagnosis STEP-4. Confirm that magnet clutch operation normal.

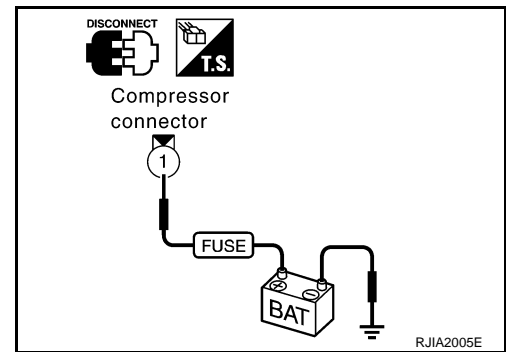

5.CHECK BCM INPUT (COMPRESSOR ON) SIGNAL

Check compressor ON/OFF signal in "Data monitor". Refer to [ATC-32, "CONSULT-III Function"](#).

A/C SW ON : AIR COND SW ON
A/C SW OFF : AIR COND SW OFF

OK or NG

- OK >> GO TO 8.
NG >> GO TO 6.

6.CHECK CIRCUIT CONTINUITY BETWEEN BCM AND UNIFIED METER AND A/C AMP.

1. Turn ignition switch OFF.
2. Disconnect BCM connector and unified meter and A/C amp. connector.

TROUBLE DIAGNOSIS

< SERVICE INFORMATION >

- Check continuity between BCM harness connector M3 terminal 27 and unified meter and A/C amp. harness connector M57 terminal 42.

27 – 42

: Continuity should exist.

OK or NG

- OK >> GO TO 7.
- NG >> Repair harness or connector.

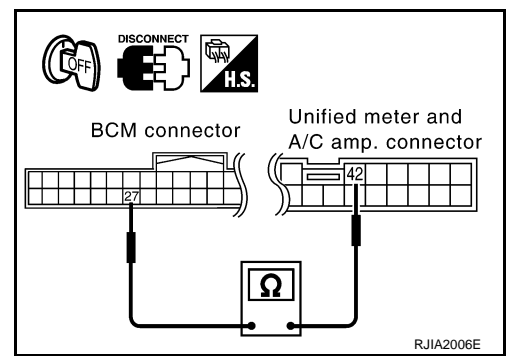

7. CHECK VOLTAGE FOR UNIFIED METER AND A/C AMP. (COMPRESSOR ON SIGNAL)

- Reconnect BCM connector and unified meter and A/C amp. connector.
- Turn ignition switch ON.
- Check voltage between unified meter and A/C amp. harness connector M57 terminal 42 and ground using an oscilloscope.

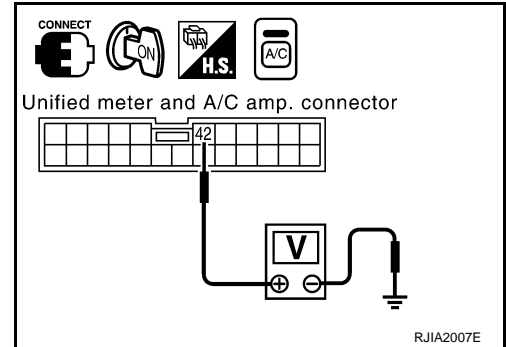

Terminals			Condition	Voltage
(+)		(-)		
Unified meter and A/C amp. connector	Terminal No.			
M57	42	Ground	A/C switch: ON (Blower motor operates.)	Approx. 0 V
			OFF switch: ON (A/C system: OFF)	<p style="text-align: right;">SJIA1423J</p>

OK or NG

- OK >> GO TO 8.
- NG-1 >> If the voltage is approx. 5 V when A/C switch is ON: Replace unified meter and A/C amp.
- NG-2 >> If the voltage is approx. 0 V when A/C switch is OFF: Replace BCM.

8. CHECK REFRIGERANT PRESSURE SENSOR

Ⓟ WITH CONSULT-III

- Start the engine.
- Check voltage of refrigerant pressure sensor in "Data monitor". Refer to [EC-127, "CONSULT-III Reference Value in Data Monitor Mode"](#) (VQ35DE) or [EC-705, "CONSULT-III Reference Value in Data Monitor Mode"](#) (VK45DE).

Ⓧ WITHOUT CONSULT-III

- Start the engine.

TROUBLE DIAGNOSIS

< SERVICE INFORMATION >

- Check voltage between ECM harness connector F101 terminal 70 and ground.

Terminals		(-)	Condition	Voltage
(+) ECM connector				
ECM connector	Terminal No.			
F101	70	Ground	A/C switch: ON (Blower motor operates.)	Approx. 1.0 - 4.0 V

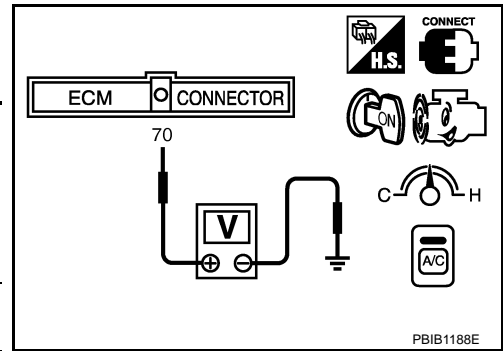

OK or NG

- OK >> • WITH CONSULT-III: GO TO 9.
 • WITHOUT CONSULT-III: GO TO 10.
 NG >> Refer to [EC-581](#) (VQ35DE) or [EC-1177](#) (VK45DE).

9. CHECK BCM INPUT (FAN ON) SIGNAL

Check FAN ON/OFF signal in "Data monitor". Refer to [ATC-32, "CONSULT-III Function"](#).

FAN SW ON : FAN ON SIG ON
FAN SW OFF : FAN ON SIG OFF

OK or NG

- OK >> GO TO 12.
 NG >> GO TO 10.

10. CHECK CIRCUIT CONTINUITY BETWEEN BCM AND UNIFIED METER AND A/C AMP.

- Turn ignition switch OFF.
- Disconnect BCM connector and unified meter and A/C amp. connector.
- Check continuity between BCM harness connector M3 terminal 28 and unified meter and A/C amp. harness connector M57 terminal 57.

28 - 57 : Continuity should exist.

OK or NG

- OK >> GO TO 11.
 NG >> Repair harness or connector.

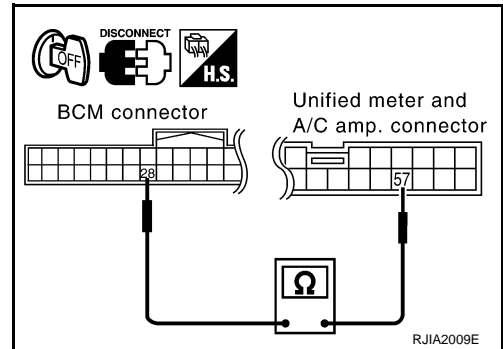

11. CHECK VOLTAGE FOR UNIFIED METER AND A/C AMP. (FAN ON SIGNAL)

- Reconnect BCM connector and unified meter and A/C amp. connector.
- Turn ignition switch ON.
- Check voltage between unified meter and A/C amp. harness connector M57 terminal 57 and ground using an oscilloscope.

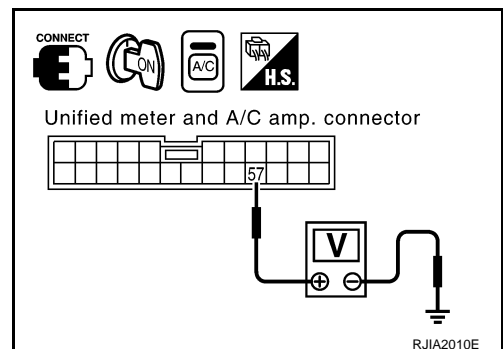

TROUBLE DIAGNOSIS

< SERVICE INFORMATION >

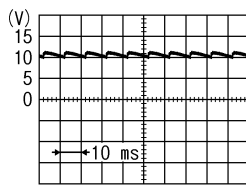
Terminals		(-)	Condition	Voltage
(+)	Terminal No.			
Unified meter and A/C amp. connector			A/C switch: ON (Blower motor operates.)	Approx. 0 V
M57	57	Ground	OFF switch: ON (A/C system: OFF)	

SJIA1474J

OK or NG

OK >> GO TO 12.

NG-1 >> If the voltage is approx. 5 V when blower motor is ON: Replace unified meter and A/C amp.

NG-2 >> If the voltage is approx. 0 V when blower motor is OFF: Replace BCM.

12. CHECK CAN COMMUNICATION

Check CAN communication. Refer to [BCS-13. "U1000 CAN Communication Circuit"](#).

- BCM – ECM
- ECM – IPDM E/R
- ECM – Unified meter and A/C amp.

OK or NG

OK >> Replace ECM

NG >> Repair or replace malfunctioning part(s).

COMPONENT INSPECTION

Refrigerant Pressure Sensor

The refrigerant pressure sensor is attached to the condenser. Make sure that the A/C refrigerant pressure and the sensor output voltage are within the specified range as shown in the A/C operating condition figure. Refer to [EC-581](#) (VQ35DE) or [EC-1177](#) (VK45DE).

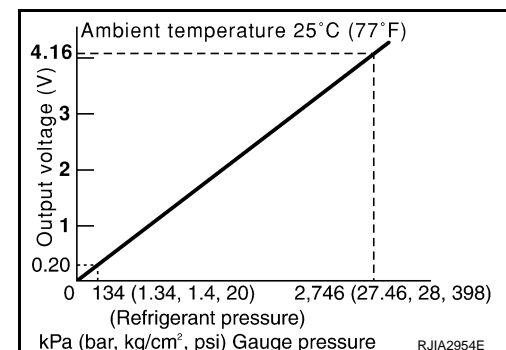
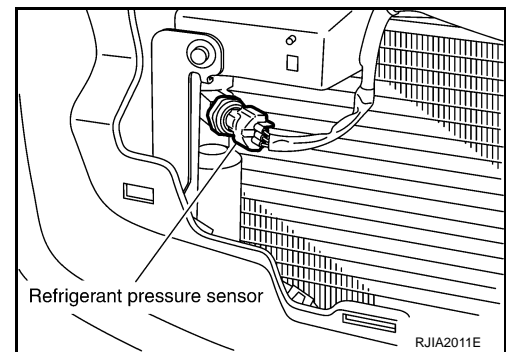

TROUBLE DIAGNOSIS

< SERVICE INFORMATION >

Insufficient Cooling

INFOID:000000001328191

SYMPTOM: Insufficient cooling

INSPECTION FLOW

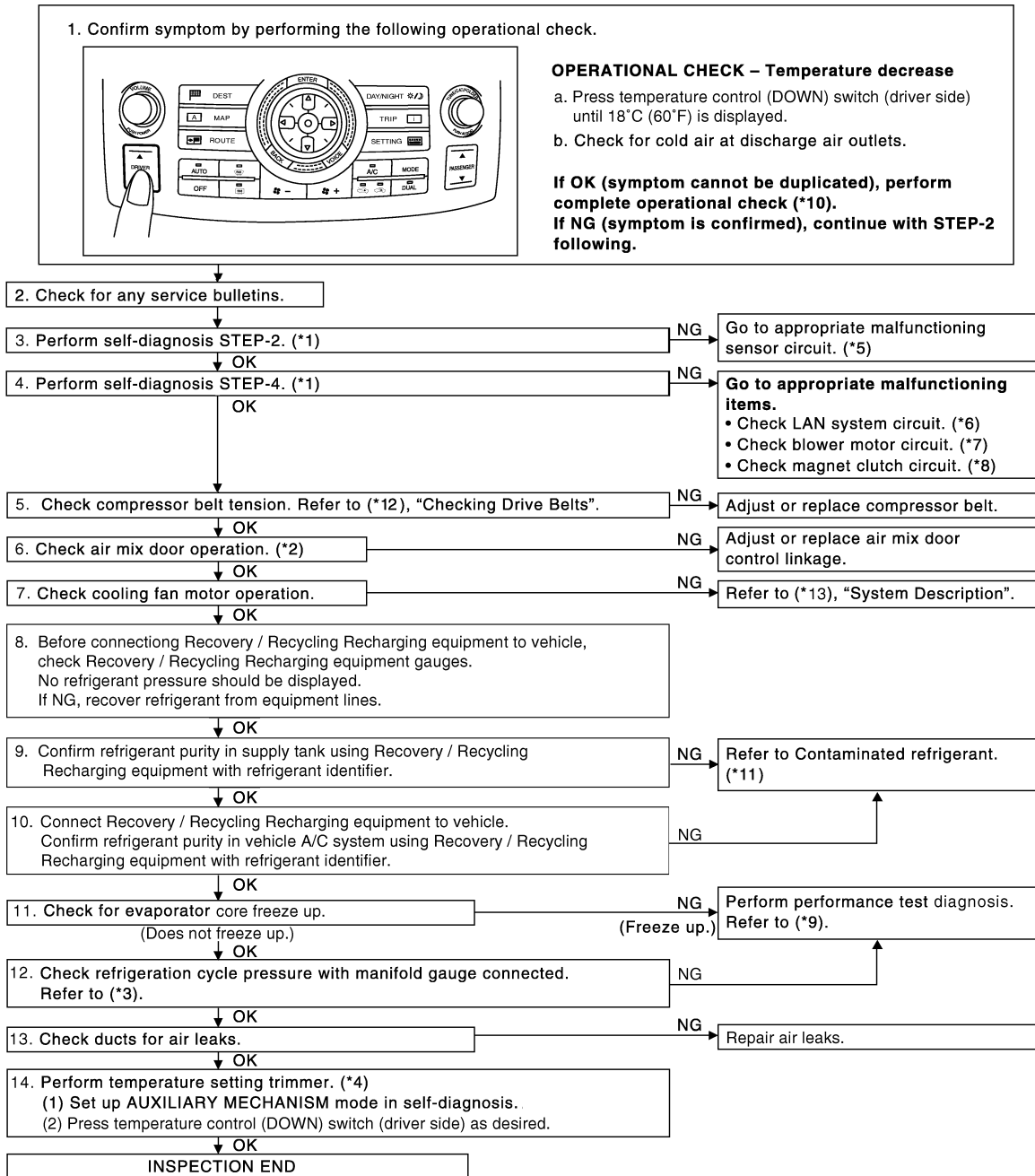

A
B
C
D
E
F
G
H
I
J
K
L
M
N
O
P

ATC

*1 [ATC-43, "Self-Diagnosis Function"](#), see No. 4 to 6.

*2 [ATC-59, "Air Mix Door Motor Circuit"](#)

*3 "Test Reading"

*4 [ATC-43, "Self-Diagnosis Function"](#)

*5 [ATC-43, "Self-Diagnosis Function"](#), see No. 13.

*6 [ATC-54, "LAN System Circuit"](#)

*7 [ATC-64, "Blower Motor Circuit"](#)

*8 [ATC-69, "Magnet Clutch Circuit"](#)

*9 "PERFORMANCE TEST DIAGNOSIS"

SJIA1592E

TROUBLE DIAGNOSIS

< SERVICE INFORMATION >

*10 [ATC-50, "Operational Check"](#)

*11 [ATC-4, "Precaution for Working with HFC-134a \(R-134a\)"](#)

*12 [EM-14, "Checking Drive Belts" \(VQ35DE\) or EM-170, "Checking Drive Belts" \(VK45DE\)](#)

*13 [EC-437, "Description" \(VQ35DE\) or EC-1030, "Description" \(VK45DE\)](#)

PERFORMANCE TEST DIAGNOSIS

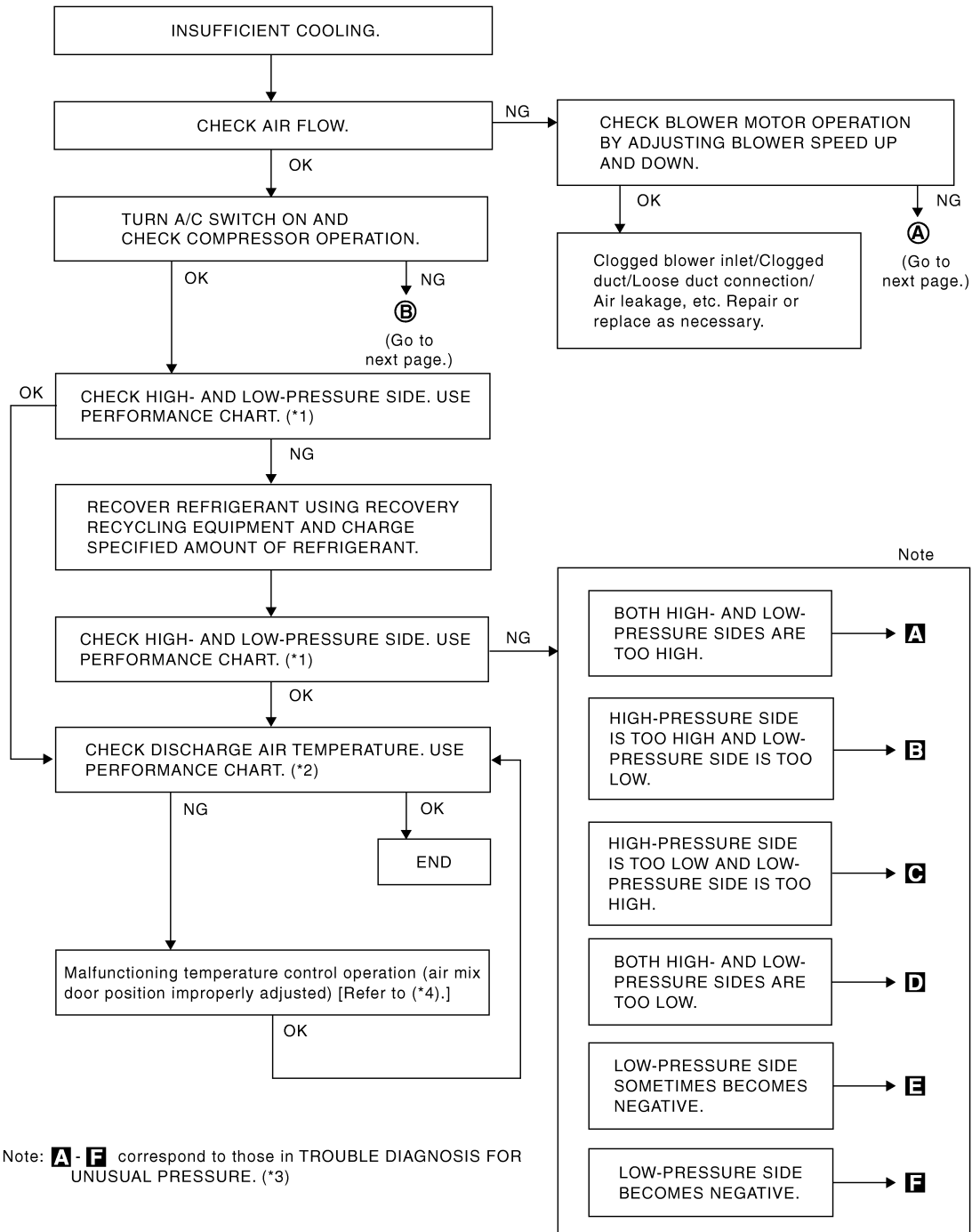

SJIA1226E

*1 "PERFORMANCE CHART"

*2 "PERFORMANCE CHART"

*3 "TROUBLE DIAGNOSIS FOR UNUSUAL PRESSURE"

*4 [ATC-59, "Air Mix Door Motor Circuit"](#)

TROUBLE DIAGNOSIS

< SERVICE INFORMATION >

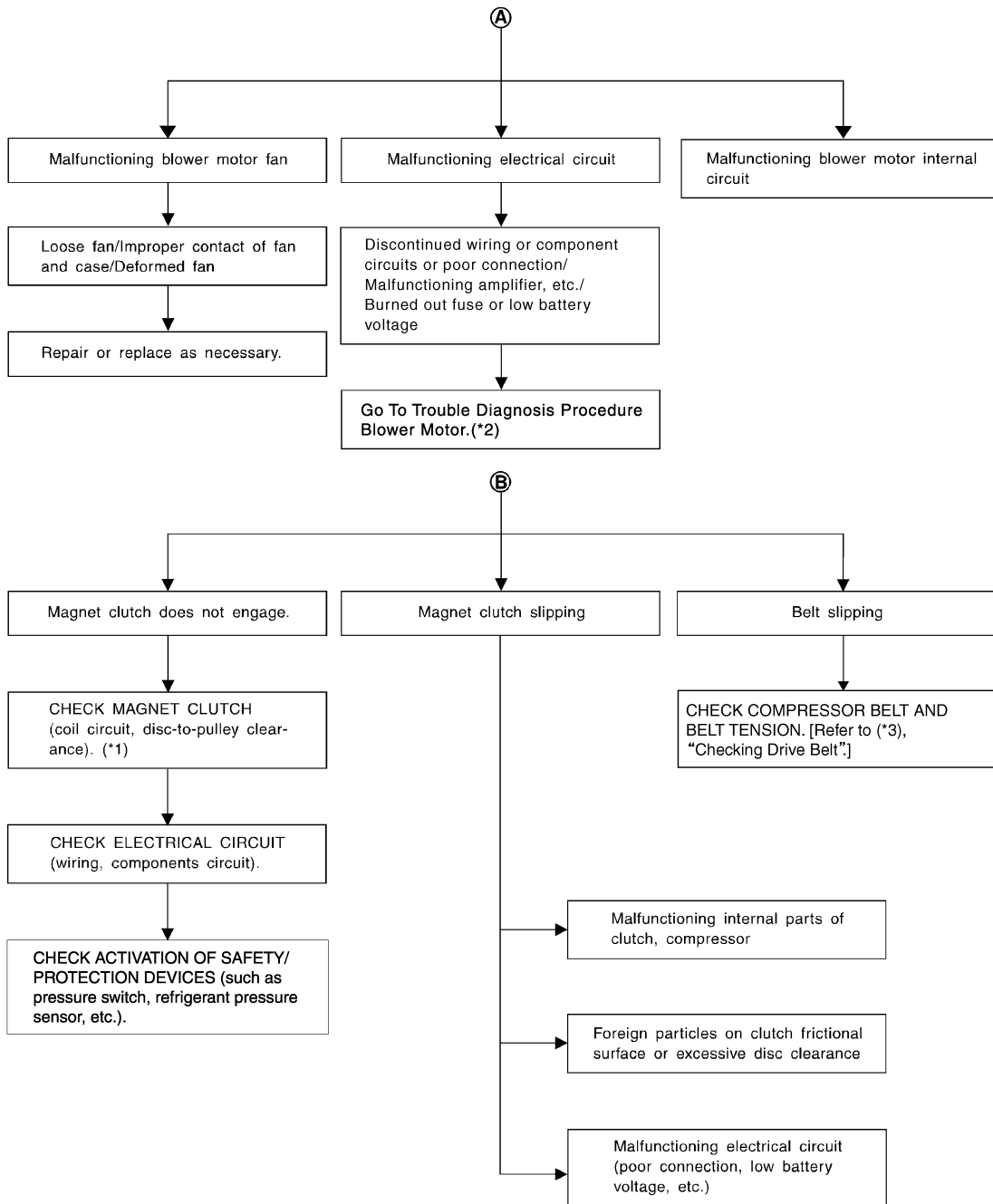

SJIA1642E

*1 [ATC-125. "Removal and Installation of Compressor Clutch"](#)

*2 [ATC-64. "Blower Motor Circuit"](#)

*3 [EM-14. "Checking Drive Belts" \(VQ35DE\)](#) or [EM-170. "Checking Drive Belts" \(VK45DE\)](#)

PERFORMANCE CHART



Test Condition

Testing must be performed as follows:

Vehicle condition	Indoors or in the shade (in a well-ventilated place)
Doors	Closed
Door windows	Open

TROUBLE DIAGNOSIS

< SERVICE INFORMATION >

Vehicle condition	Indoors or in the shade (in a well-ventilated place)
Hood	Open
TEMP.	Max. COLD
Mode switch	 (Ventilation) set
Intake switch	 (Recirculation) set
 Fan (blower) speed	Max. speed set
Engine speed	Idle speed

Operate the air conditioning system for 10 minutes before taking measurements.

Test Reading

Recirculating-to-discharge Air Temperature Table

Inside air (Recirculating air) at blower assembly inlet		Discharge air temperature at center ventilator °C (°F)
Relative humidity %	Air temperature °C (°F)	
50 - 60	20 (68)	11.2 - 13.2 (52 - 56)
	25 (77)	12.2 - 14.8 (54 - 59)
	30 (86)	15.5 - 18.6 (60 - 65)
	35 (95)	21.0 - 24.5 (70 - 76)
	40 (104)	28.7 - 32.6 (84 - 91)
60 - 70	20 (68)	13.2 - 15.2 (56 - 59)
	25 (77)	14.8 - 17.3 (59 - 63)
	30 (86)	18.6 - 21.6 (65 - 71)
	35 (95)	24.5 - 28.0 (76 - 82)
	40 (104)	32.6 - 36.5 (91 - 98)

Ambient Air Temperature-to-operating Pressure Table

Ambient air		High-pressure (Discharge side) kPa (kg/cm ² , psi)	Low-pressure (Suction side) kPa (kg/cm ² , psi)
Relative humidity %	Air temperature °C (°F)		
50 - 70	20 (68)	961 - 1,167 (9.8 - 11.9, 139 - 169)	216 - 265 (2.2 - 2.7, 31 - 38)
	25 (77)	1,108 - 1,353 (11.3 - 13.8, 161 - 196)	230 - 281 (2.3 - 2.9, 33 - 41)
	30 (86)	1,275 - 1,549 (13.0 - 15.8, 185 - 225)	261 - 320 (2.7 - 3.3, 38 - 46)
	35 (95)	1,549 - 1,893 (15.8 - 19.3, 225 - 274)	297 - 364 (3.0 - 3.7, 43 - 53)
	40 (104)	1,814 - 2,216 (18.5 - 22.6, 263 - 321)	357 - 435 (3.6 - 4.4, 52 - 63)

TROUBLE DIAGNOSIS FOR UNUSUAL PRESSURE

Whenever system's high and/or low side pressure(s) is/are unusual, diagnose using a manifold gauge. The marker above the gauge scale in the following tables indicates the standard (usual) pressure range. Since the standard (usual) pressure, however, differs from vehicle to vehicle, refer to above table (Ambient air temperature-to-operating pressure table).

Both High- and Low-pressure Sides are Too High

TROUBLE DIAGNOSIS

< SERVICE INFORMATION >

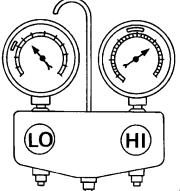
Gauge indication	Refrigerant cycle	Probable cause	Corrective action
<p>Both high- and low-pressure sides are too high.</p>  <p style="text-align: right; font-size: small;">AC359A</p>	<p>The pressure returns to normal soon after water is splashed on condenser.</p>	<p>Excessive refrigerant charge in refrigeration cycle.</p>	<p>Reduce refrigerant until specified pressure is obtained.</p>
	<p>Air suction by cooling fan is insufficient.</p>	<p>Insufficient condenser cooling performance. ↓ 1. Condenser fins are clogged. 2. Improper fan rotation of cooling fan.</p>	<ul style="list-style-type: none"> • Clean condenser. • Check and repair cooling fan as necessary.
	<ul style="list-style-type: none"> • Low-pressure pipe is not cold. • When compressor is stopped high-pressure value quickly drops by approximately 196 kPa (2 kg/cm², 28 psi). It then decreases gradually thereafter. 	<p>Poor heat exchange in condenser (After compressor operation stops, high-pressure decreases too slowly). ↓ Air in refrigeration cycle.</p>	<p>Evacuate repeatedly and re-charge system.</p>
	<p>Engine tends to overheat.</p>	<p>Engine cooling systems malfunction.</p>	<p>Check and repair each engine cooling system.</p>
	<ul style="list-style-type: none"> • An area of the low-pressure pipe is colder than areas near the evaporator outlet. • Low-pressure pipe is sometimes covered with frost. 	<ul style="list-style-type: none"> • Excessive liquid refrigerant on low-pressure side. • Excessive refrigerant discharge flow. • Expansion valve is open a little compared with the specification. <p>↓ Improper expansion valve adjustment.</p>	<p>Replace expansion valve.</p>

High-pressure Side is Too High and Low-pressure Side is Too Low

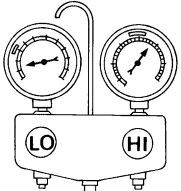
Gauge indication	Refrigerant cycle	Probable cause	Corrective action
<p>High-pressure side is too high and low-pressure side is too low.</p>  <p style="text-align: right; font-size: small;">AC360A</p>	<p>Upper side of condenser and high-pressure side are hot, however, liquid tank is not so hot.</p>	<p>High-pressure tube or parts located between compressor and condenser are clogged or crushed.</p>	<ul style="list-style-type: none"> • Check and repair or replace malfunctioning parts. • Check lubricant for contamination.

High-pressure Side is Too Low and Low-pressure Side is Too High

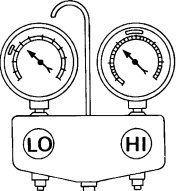
Gauge indication	Refrigerant cycle	Probable cause	Corrective action
<p>High-pressure side is too low and low-pressure side is too high.</p>  <p style="text-align: right; font-size: small;">AC356A</p>	<p>High- and low-pressure sides become equal soon after compressor operation stops.</p>	<p>Compressor pressure operation is improper. ↓ Damaged inside compressor packings.</p>	<p>Replace compressor.</p>
	<p>No temperature difference between high- and low-pressure sides.</p>	<p>Compressor pressure operation is improper. ↓ Damaged inside compressor packings.</p>	<p>Replace compressor.</p>

Both High- and Low-pressure Sides are Too Low

TROUBLE DIAGNOSIS

< SERVICE INFORMATION >

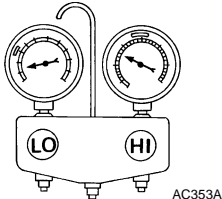
Gauge indication	Refrigerant cycle	Probable cause	Corrective action
<p>Both high- and low-pressure sides are too low.</p>  <p style="text-align: right; font-size: small;">AC353A</p>	<ul style="list-style-type: none"> There is a big temperature difference between liquid tank outlet and inlet. Outlet temperature is extremely low. Liquid tank inlet and expansion valve are frosted. 	Liquid tank inside is slightly clogged.	<ul style="list-style-type: none"> Replace liquid tank. Check lubricant for contamination.
	<ul style="list-style-type: none"> Temperature of expansion valve inlet is extremely low as compared with areas near liquid tank. Expansion valve inlet is frosted. Temperature difference occurs somewhere in high-pressure side. 	High-pressure pipe located between liquid tank and expansion valve is clogged.	<ul style="list-style-type: none"> Check and repair malfunctioning parts. Check lubricant for contamination.
	Expansion valve and liquid tank are warm or slightly cool when touched.	Low refrigerant charge. ↓ Leaking fittings or components.	Check refrigerant for leaks. Refer to ATC-138, "Checking of Refrigerant Leaks" .
	There is a big temperature difference between expansion valve inlet and outlet while the valve itself is frosted.	Expansion valve closes a little compared with the specification. ↓ 1. Improper expansion valve adjustment. 2. Malfunctioning expansion valve. 3. Outlet and inlet may be clogged.	<ul style="list-style-type: none"> Remove foreign particles by using compressed air. Replace expansion valve. Check lubricant for contamination.
	An area of the low-pressure pipe is colder than areas near the evaporator outlet.	Low-pressure pipe is clogged or crushed.	<ul style="list-style-type: none"> Check and repair malfunctioning parts. Check lubricant for contamination.
	Air flow volume is not enough or is too low.	Evaporator is frozen.	<ul style="list-style-type: none"> Check intake sensor circuit. Refer to ATC-94, "Intake Sensor Circuit". Replace compressor. Repair evaporator fins. Replace evaporator. Refer to ATC-64, "Blower Motor Circuit".

Low-pressure Side Sometimes Becomes Negative

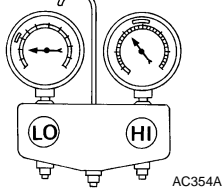
Gauge indication	Refrigerant cycle	Probable cause	Corrective action
<p>Low-pressure side sometimes becomes negative.</p>  <p style="text-align: right; font-size: small;">AC354A</p>	<ul style="list-style-type: none"> Air conditioning system does not function and does not cyclically cool the compartment air. The system constantly functions for a certain period of time after compressor is stopped and restarted. 	Refrigerant does not discharge cyclically. ↓ Moisture is frozen at expansion valve outlet and inlet. ↓ Water is mixed with refrigerant.	<ul style="list-style-type: none"> Drain water from refrigerant or replace refrigerant. Replace liquid tank.

Low-pressure Side Becomes Negative

TROUBLE DIAGNOSIS

< SERVICE INFORMATION >

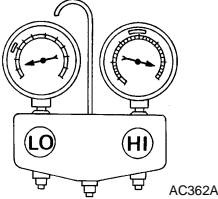
Gauge indication	Refrigerant cycle	Probable cause	Corrective action
<p>Low-pressure side becomes negative.</p> 	<p>Liquid tank or front/rear side of expansion valve's pipe is frosted or wet with dew.</p>	<p>High-pressure side is closed and refrigerant does not flow. ↓ Expansion valve or liquid tank is frosted.</p>	<p>Leave the system at rest until no frost is present. Start it again to check whether or not the malfunction is caused by water or foreign particles.</p> <ul style="list-style-type: none"> If water is the cause, initially cooling is okay. Then the water freezes causing a blockage. Drain water from refrigerant or replace refrigerant. If due to foreign particles, remove expansion valve and remove the particles with dry and compressed air (not shop air). If either of the above methods cannot correct the malfunction, replace expansion valve. Replace liquid tank. Check lubricant for contamination.

DIAGNOSIS PROCEDURE FOR INSUFFICIENT COOLING

SYMPTOM: Insufficient cooling

1. CHECK POWER SUPPLY FOR ECV (ELECTRONIC CONTROL VALVE)

1. Disconnect compressor (ECV) connector.
2. Turn ignition switch ON.
3. Check voltage between compressor (ECV) harness connector F6 terminal 2 and ground.

2 – ground : Battery voltage

OK or NG

- OK >> GO TO 2.
 NG >> Check power supply circuit and 10A fuse [No. 12, located in the fuse block (J/B)]. Refer to [PG-77](#).
- If fuse is OK, check harness for open circuit. Repair or replace if necessary.
 - If fuse is NG, check harness for short circuit and replace fuse.

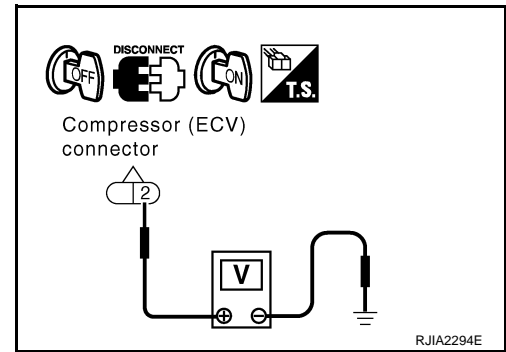

2. CHECK ECV CONTROL SIGNAL

1. Turn ignition switch OFF.
2. Reconnect compressor (ECV) connector.
3. Perform self-diagnosis. Refer to [ATC-43, "Self-Diagnosis Function"](#).
4. Set in self-diagnosis STEP-4 (Code No. 45). Refer to [ATC-43, "Self-Diagnosis Function"](#).
5. Confirm ECV control signal between unified meter and A/C amp. harness connector M57 terminal 45 and ground using an oscilloscope.

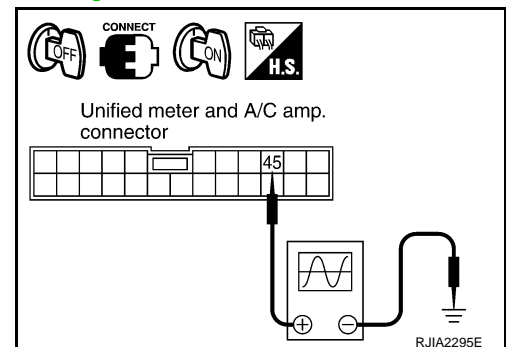

TROUBLE DIAGNOSIS

< SERVICE INFORMATION >

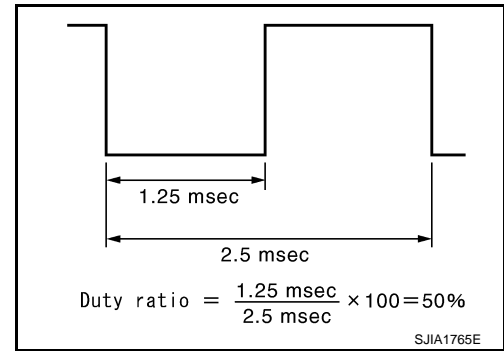

OK or NG

- OK >> Replace compressor.
- NG >> GO TO 3.

3. CHECK CIRCUIT CONTINUITY BETWEEN ECV AND UNIFIED METER AND A/C AMP.

1. Turn ignition switch OFF.
2. Disconnect compressor (ECV) and unified meter and A/C amp. connector.
3. Check continuity between compressor (ECV) harness connector F6 terminal 3 and unified meter and A/C amp. harness connector M57 terminal 45.

3 – 45 : Continuity should exist.

OK or NG

- OK >> GO TO 4.
- NG >> Repair harness or connector.

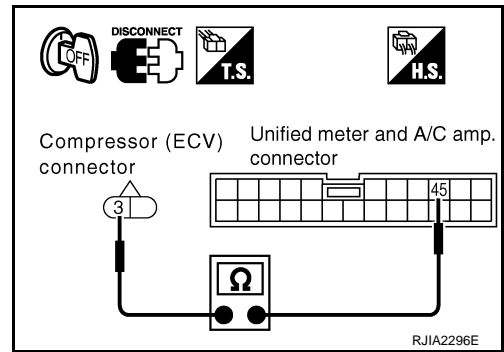

4. CHECK ECV

Check continuity between compressor (ECV) connector F6 terminals 2 and 3.

2 – 3 : Continuity should exist.

OK or NG

- OK >> Replace unified meter and A/C amp.
- NG >> Replace compressor.

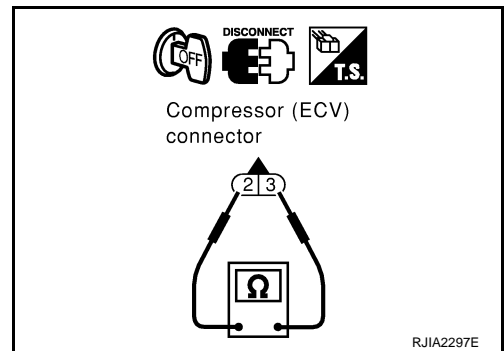

Insufficient Heating

SYMPTOM: Insufficient heating

INSPECTION FLOW

INFOID:000000001328192

TROUBLE DIAGNOSIS

< SERVICE INFORMATION >

1. Confirm symptom by performing the following operational check.

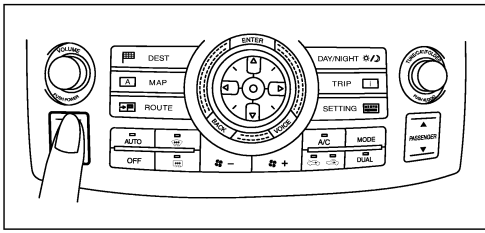

OPERATIONAL CHECK - Temperature increase

- Press temperature control (UP) switch (driver side) until 32°C (90°F) is displayed.
- Check for hot air at discharge air outlets.

If OK (symptom cannot be duplicated), perform complete operational check (*1).
If NG (symptom is confirmed), continue with STEP-2 following.

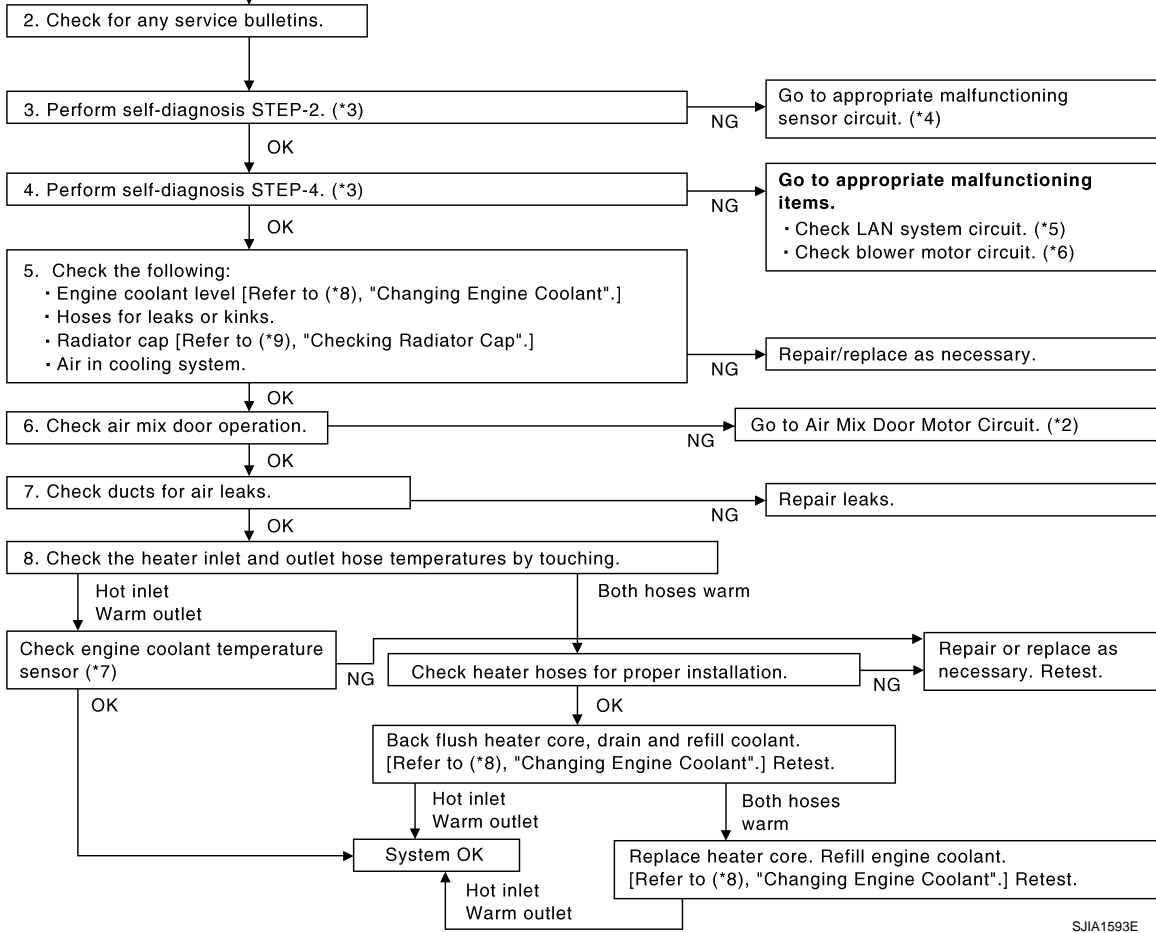

*1 [ATC-50. "Operational Check"](#)

*2 [ATC-59. "Air Mix Door Motor Circuit"](#)

*3 [ATC-43. "Self-Diagnosis Function"](#), see No. 4 to 6.

*4 [ATC-43. "Self-Diagnosis Function"](#), see No. 13.

*5 [ATC-54. "LAN System Circuit"](#)

*6 [ATC-64. "Blower Motor Circuit"](#)

*7 [EC-193 \(VQ35DE\)](#) or [EC-779 \(VK45DE\)](#)

*8 [CO-10. "Changing Engine Coolant"](#) (VQ35DE) or [CO-37. "Changing Engine Coolant"](#) (VK45DE)

*9 [CO-14. "Checking Radiator Cap"](#) (VQ35DE) or [CO-42. "Checking Radiator Cap"](#) (VK45DE)

Noise

INFOID:000000001328193

SYMPTOM: Noise

INSPECTION FLOW

TROUBLE DIAGNOSIS

< SERVICE INFORMATION >

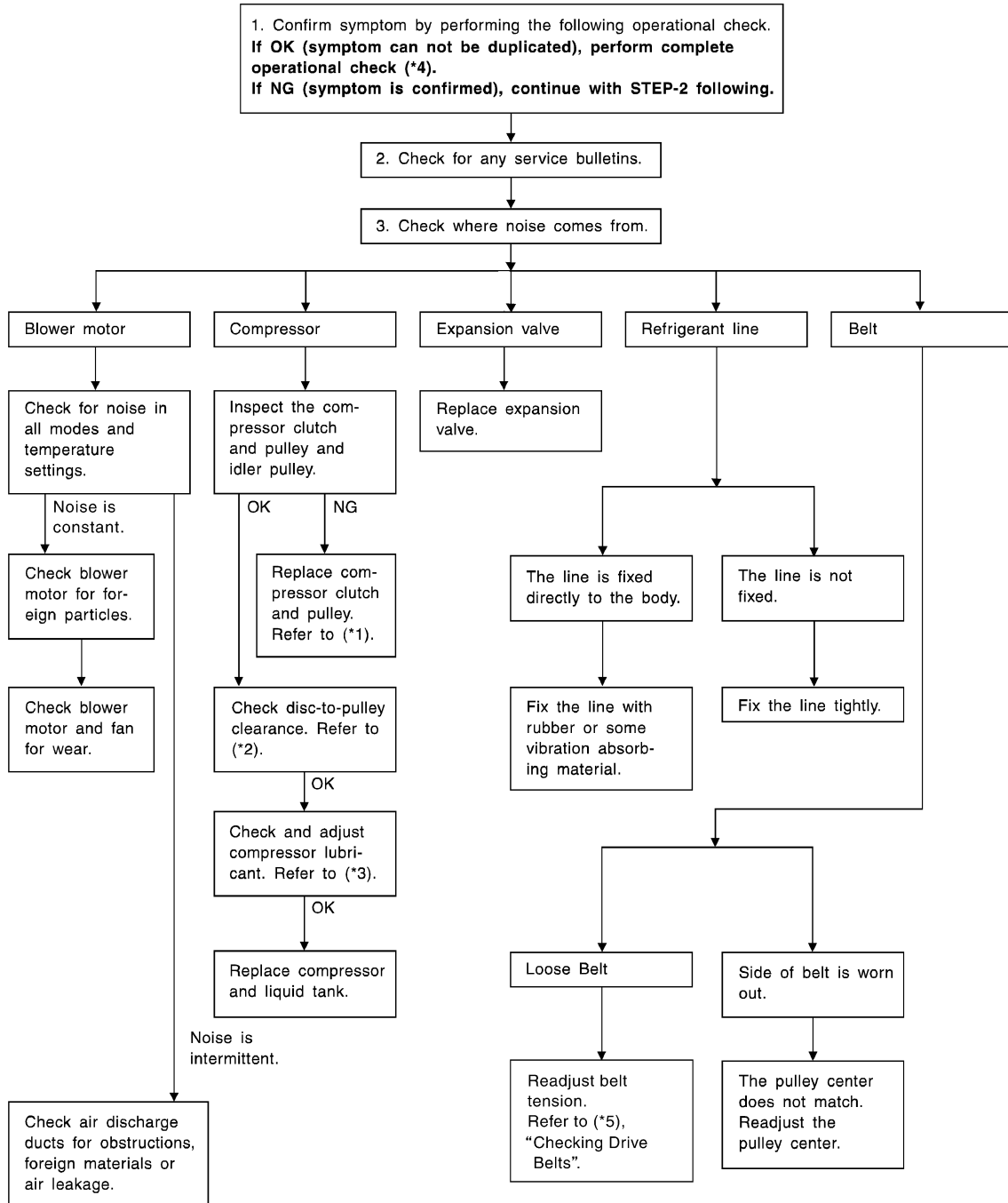

RJIA3108E

*1 [ATC-125, "Removal and Installation of Compressor Clutch"](#)

*2 [ATC-125, "Removal and Installation of Compressor Clutch"](#)

*3 [ATC-22, "Maintenance of Lubricant Quantity in Compressor"](#)

*4 [ATC-50, "Operational Check"](#)

*5 [EM-14, "Checking Drive Belts" \(VQ35DE\) or EM-170, "Checking Drive Belts" \(VK45DE\)](#)

Self-Diagnosis

SYMPTOM: Self-diagnosis cannot be performed.

INSPECTION FLOW

INFOID:000000001328194

TROUBLE DIAGNOSIS

< SERVICE INFORMATION >

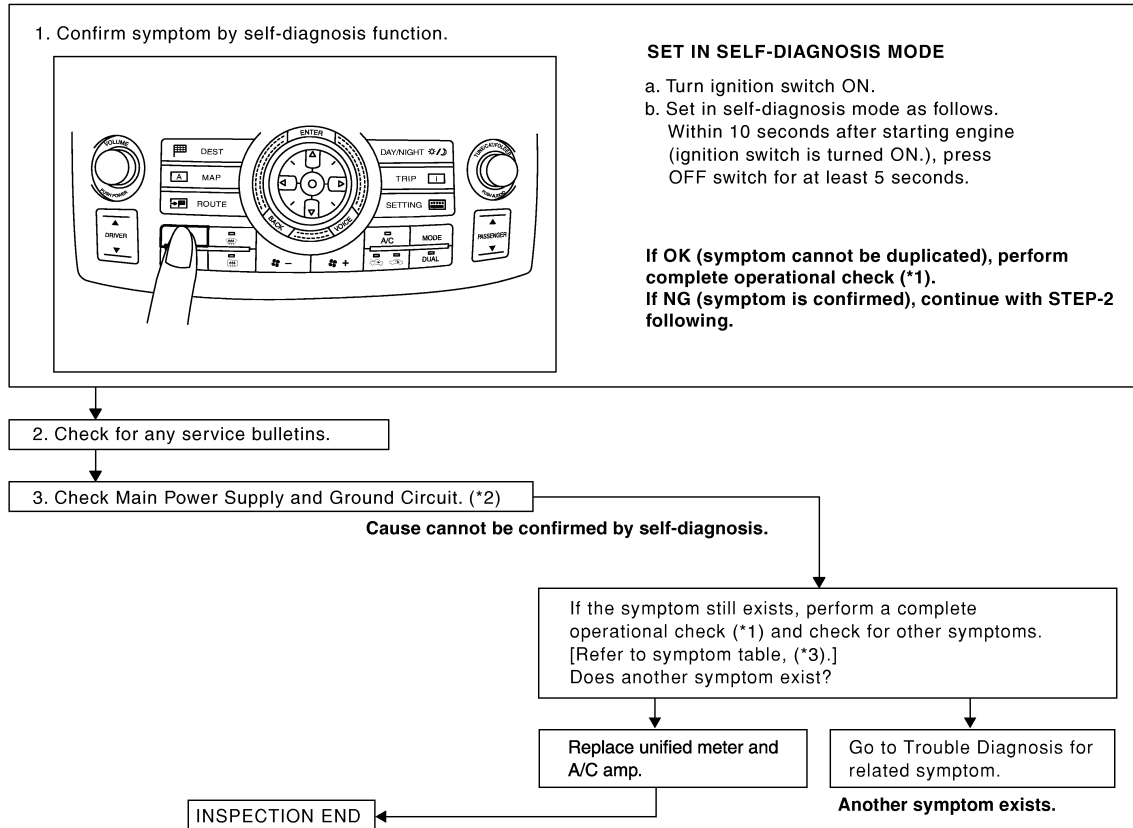

SJIA1803E

*1 [ATC-50. "Operational Check"](#)

*2 [ATC-52. "Power Supply and Ground Circuit for Auto Amp"](#)

*3 [ATC-32. "How to Perform Trouble Diagnosis for Quick and Accurate Repair"](#)

ATC

Memory Function

INFOID:000000001328195

SYMPTOM: Memory function does not operate.

INSPECTION FLOW

TROUBLE DIAGNOSIS

< SERVICE INFORMATION >

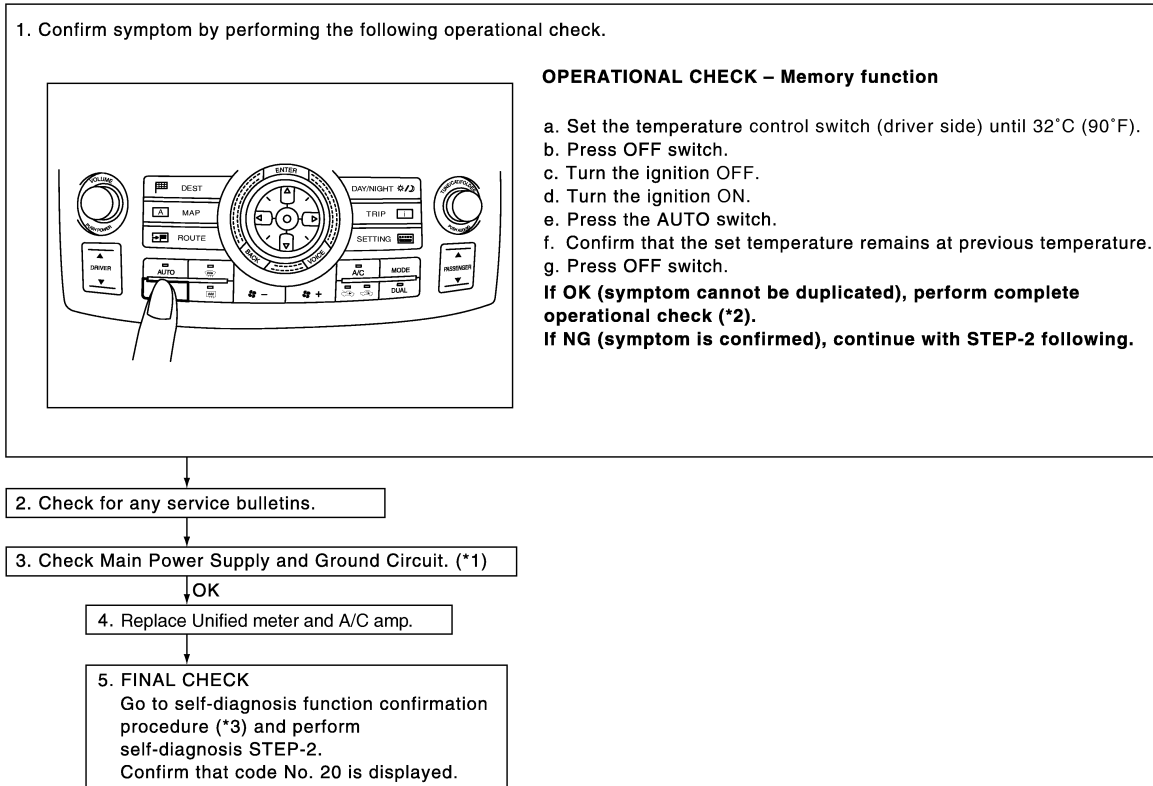

SJIA1595E

*1 [ATC-52, "Power Supply and Ground Circuit for Auto Amp"](#) *2 [ATC-50, "Operational Check"](#)

*3 [ATC-43, "Self-Diagnosis Function"](#)

Ambient Sensor Circuit

INFOID:000000001328196

COMPONENT DESCRIPTION

Ambient Sensor

The ambient sensor is attached on the hood lock stay. It detects ambient temperature and converts it into a resistance value which is then input into the unified meter and A/C amp.

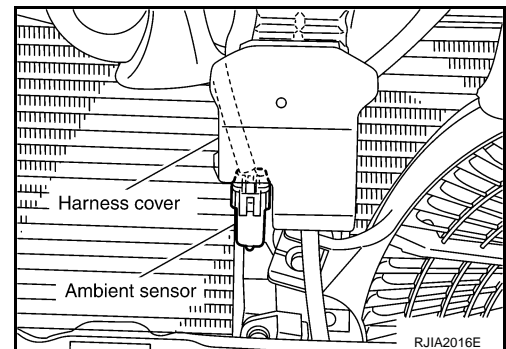

AMBIENT TEMPERATURE INPUT PROCESS

The unified meter and A/C amp. includes a processing circuit for the ambient sensor input. However, when the temperature detected by the ambient sensor increases quickly, the processing circuit retards the unified meter and A/C amp. function. It only allows the unified meter and A/C amp. to recognize an ambient temperature increase of 0.33°C (0.6°F) per 100 seconds.

As an example, consider stopping for a few minutes after high speed driving. Although the actual ambient temperature has not changed, the temperature detected by the ambient sensor will increase. This is because the heat from the engine compartment can radiate to the front grille area, location of the ambient sensor.

DIAGNOSIS PROCEDURE FOR AMBIENT SENSOR

TROUBLE DIAGNOSIS

< SERVICE INFORMATION >

SYMPTOM: Ambient sensor circuit is open or shorted. (21 or -21 is indicated on unified meter and A/C amp. as a result of performing self-diagnosis STEP-2.)

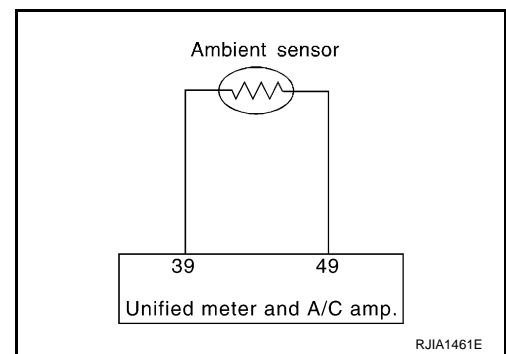

1. CHECK VOLTAGE BETWEEN AMBIENT SENSOR AND GROUND

1. Disconnect ambient sensor connector.
2. Turn ignition switch ON.
3. Check voltage between ambient sensor harness connector E34 terminal 1 and ground.

1 – Ground : Approx. 5 V

OK or NG

- OK >> GO TO 2.
- NG >> GO TO 4.

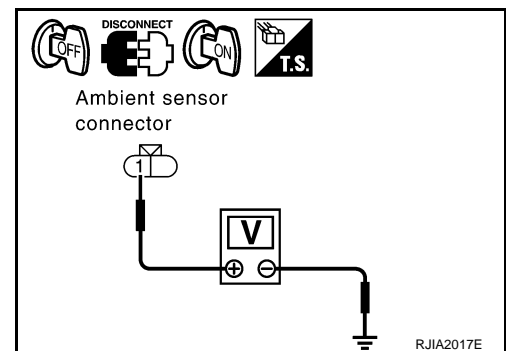

2. CHECK CIRCUIT CONTINUITY BETWEEN AMBIENT SENSOR AND UNIFIED METER AND A/C AMP.

1. Turn ignition switch OFF.
2. Disconnect unified meter and A/C amp. connector.
3. Check continuity between ambient sensor harness connector E34 terminal 2 and unified meter and A/C amp. harness connector M57 terminal 49.

2 – 49 : Continuity should exist.

OK or NG

- OK >> GO TO 3.
- NG >> Repair harness or connector.

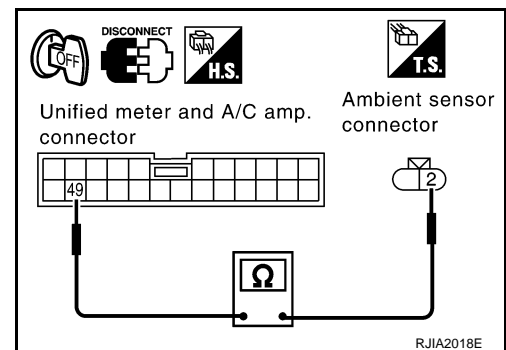

3. CHECK AMBIENT SENSOR

Refer to "Ambient Sensor".

OK or NG

- OK >> 1. Replace unified meter and A/C amp.
2. Go to self-diagnosis [ATC-43. "Self-Diagnosis Function"](#) and perform self-diagnosis STEP-2. Confirm that code No. 20 is displayed.
- NG >> 1. Replace ambient sensor.
2. Go to self-diagnosis [ATC-43. "Self-Diagnosis Function"](#) and perform self-diagnosis STEP-2. Confirm that code No. 20 is displayed.

4. CHECK CIRCUIT CONTINUITY BETWEEN AMBIENT SENSOR AND UNIFIED METER AND A/C AMP.

1. Turn ignition switch OFF.
2. Disconnect unified meter and A/C amp. connector.

A
B
C
D
E
F
G
H
I
K
L
M
N
O
P

ATC

TROUBLE DIAGNOSIS

< SERVICE INFORMATION >

3. Check continuity between ambient sensor harness connector E34 terminal 1 and unified meter and A/C amp. harness connector M57 terminal 39.

1 – 39 : Continuity should exist.

4. Check continuity between ambient sensor harness connector E34 terminal 1 and ground.

1 – Ground : Continuity should not exist.

OK or NG

- OK >> 1. Replace unified meter and A/C amp.
 2. Go to self-diagnosis [ATC-43. "Self-Diagnosis Function"](#) and perform self-diagnosis STEP-2. Confirm that code No. 20 is displayed.
- NG >> Repair harness or connector.

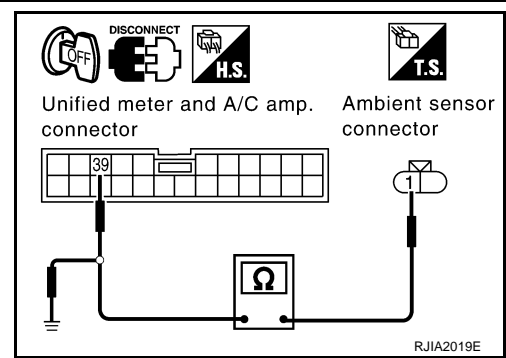

COMPONENT INSPECTION

Ambient Sensor

After disconnecting ambient sensor connector E34, measure resistance between terminals 1 and 2 at sensor side. Refer to the table below.

Temperature °C (°F)	Resistance kΩ
-15 (5)	12.73
-10 (14)	9.92
-5 (23)	7.80
0 (32)	6.19
5 (41)	4.95
10 (50)	3.99
15 (59)	3.24
20 (68)	2.65
25 (77)	2.19
30 (86)	1.81
35 (95)	1.51
40 (104)	1.27
45 (113)	1.07

If NG, replace ambient sensor.

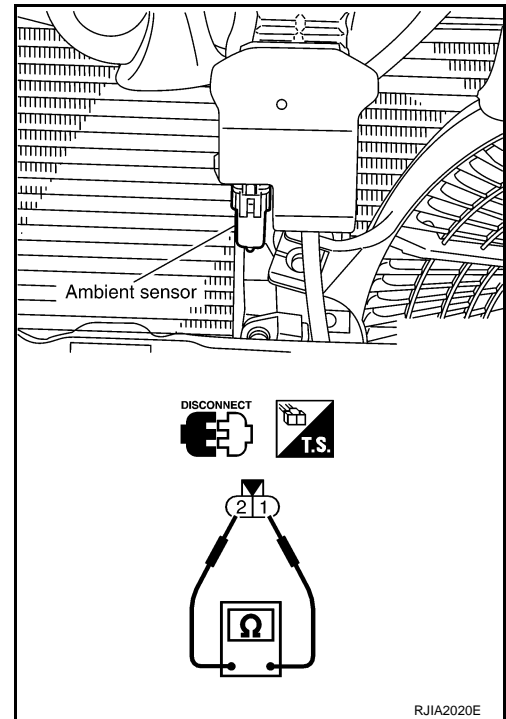

In-vehicle Sensor Circuit

INFOID:000000001328197

COMPONENT DESCRIPTION

In-vehicle Sensor

The in-vehicle sensor is located on instrument driver lower panel. It converts variations in temperature of compartment air drawn from the aspirator into a resistance value. It is then input into the unified meter and A/C amp.

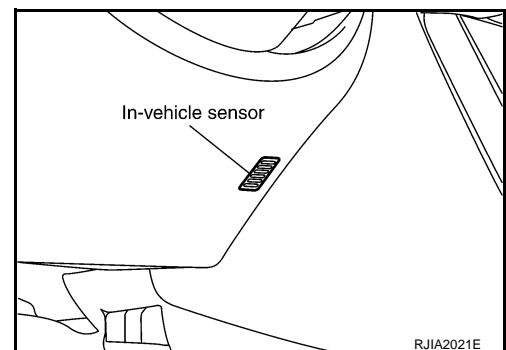

TROUBLE DIAGNOSIS

< SERVICE INFORMATION >

Aspirator

The aspirator is located on driver's side of heater & cooling unit assembly. It produces vacuum pressure due to air discharged from the heater & cooling unit assembly, continuously taking compartment air in the aspirator.

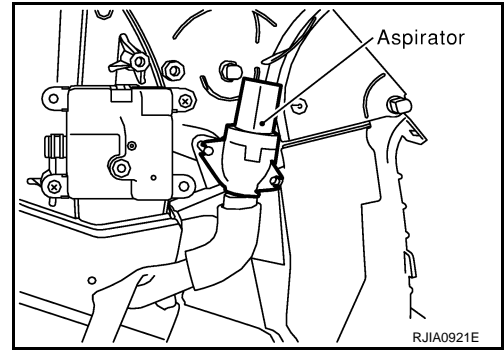

A
B
C
D

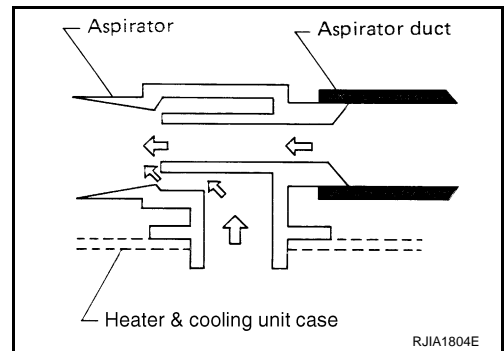

E
F
G
H

DIAGNOSIS PROCEDURE FOR IN-VEHICLE SENSOR

SYMPTOM: In-vehicle sensor circuit is open or shorted. (22 or -22 is indicated on unified meter and A/C amp. as a result of performing self-diagnosis STEP-2.)

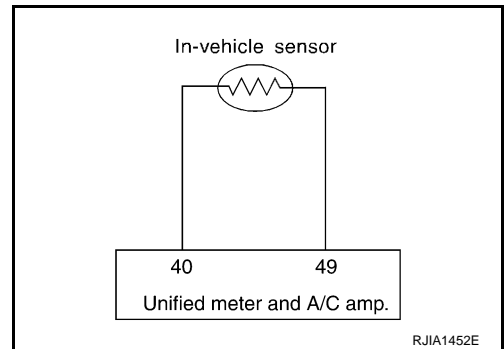

I

ATC

K

1. CHECK VOLTAGE BETWEEN IN-VEHICLE SENSOR AND GROUND

1. Disconnect in-vehicle sensor connector.
2. Turn ignition switch ON.
3. Check voltage between in-vehicle sensor harness connector M46 terminal 1 and ground.

1 – Ground : Approx. 5 V

OK or NG

- OK >> GO TO 2.
NG >> GO TO 4.

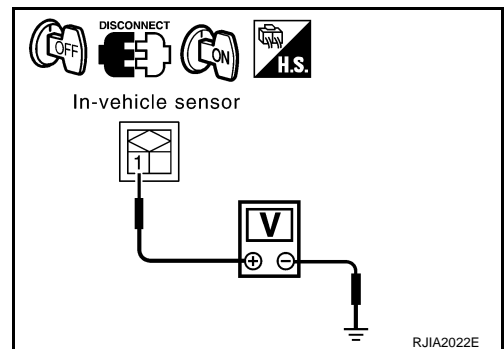

L

M

N

O

P

2. CHECK CIRCUIT CONTINUITY BETWEEN IN-VEHICLE SENSOR AND UNIFIED METER AND A/C AMP.

1. Turn ignition switch OFF.
2. Disconnect unified meter and A/C amp. connector.

TROUBLE DIAGNOSIS

< SERVICE INFORMATION >

3. Check continuity between in-vehicle sensor harness connector M46 terminal 2 and unified meter and A/C amp. harness connector M57 terminal 49.

2 – 49 : Continuity should exist.

OK or NG

- OK >> GO TO 3.
NG >> Repair harness or connector.

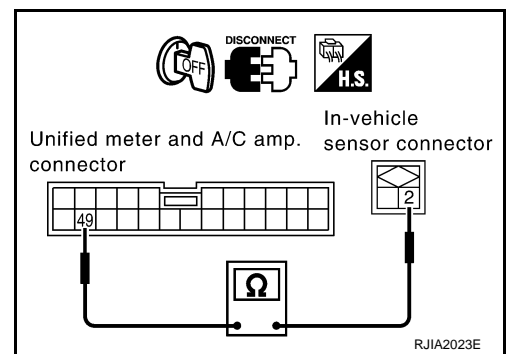

3. CHECK IN-VEHICLE SENSOR

Refer to "In-vehicle Sensor".

OK or NG

- OK >> 1. Replace unified meter and A/C amp.
2. Go to self-diagnosis [ATC-43. "Self-Diagnosis Function"](#) and perform self-diagnosis STEP-2. Confirm that code No. 20 is displayed.
- NG >> 1. Replace in-vehicle sensor.
2. Go to self-diagnosis [ATC-43. "Self-Diagnosis Function"](#) and perform self-diagnosis STEP-2. Confirm that code No. 20 is displayed.

4. CHECK CIRCUIT CONTINUITY BETWEEN IN-VEHICLE SENSOR AND UNIFIED METER AND A/C AMP.

1. Turn ignition switch OFF.
2. Disconnect unified meter and A/C amp. connector.
3. Check continuity between in-vehicle sensor harness connector M46 terminal 1 and unified meter and A/C amp. harness connector M57 terminal 40.

1 – 40 : Continuity should exist.

4. Check continuity between in-vehicle sensor harness connector M46 terminal 1 and ground.

1 – Ground : Continuity should not exist.

OK or NG

- OK >> 1. Replace unified meter and A/C amp.
2. Go to self-diagnosis [ATC-43. "Self-Diagnosis Function"](#) and perform self-diagnosis STEP-2. Confirm that code No. 20 is displayed.
- NG >> Repair harness or connector.

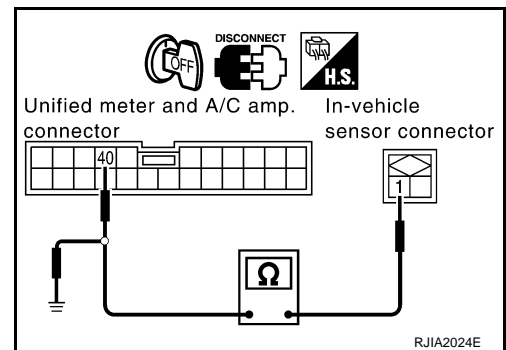

COMPONENT INSPECTION

In-vehicle Sensor

TROUBLE DIAGNOSIS

< SERVICE INFORMATION >

After disconnecting in-vehicle sensor connector M46, measure resistance between terminals 1 and 2 at sensor side. Refer to the table below.

Temperature °C (°F)	Resistance kΩ
-15 (5)	12.73
-10 (14)	9.92
-5 (23)	7.80
0 (32)	6.19
5 (41)	4.95
10 (50)	3.99
15 (59)	3.24
20 (68)	2.65
25 (77)	2.19
30 (86)	1.81
35 (95)	1.51
40 (104)	1.27
45 (113)	1.07

If NG, replace in-vehicle sensor.

Sunload Sensor Circuit

COMPONENT DESCRIPTION

Sunload Sensor

The sunload sensor is located on the passenger's side front defroster grille. It detects sunload entering through windshield by means of a photo diode. The sensor converts the sunload into a current value which is then input into the unified meter and A/C amp.

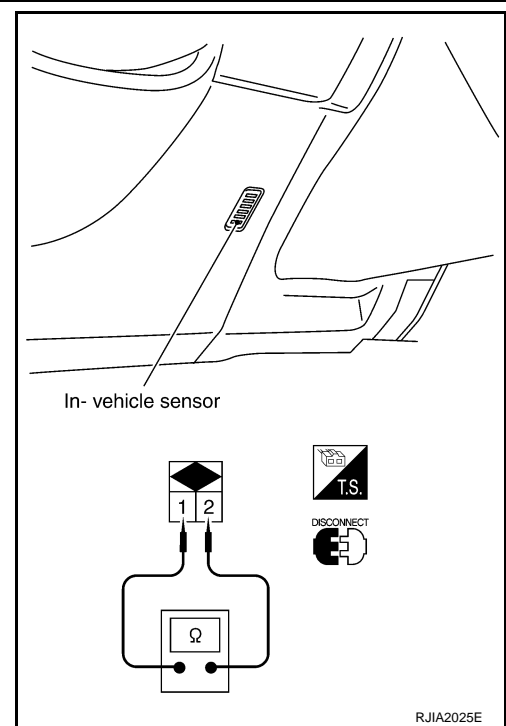

INFOID:000000001328198

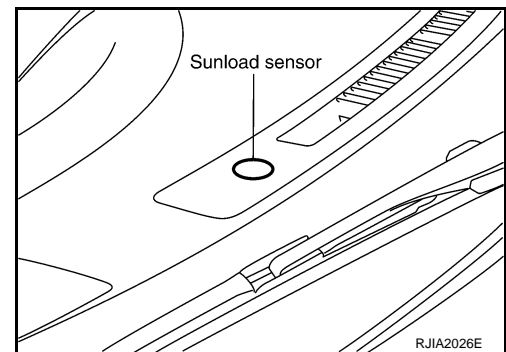

SUNLOAD INPUT PROCESS

The unified meter and A/C amp. also includes a processing circuit which averages the variations in detected sunload over a period of time. This prevents drastic swings in the ATC system operation due to small or quick variations in detected sunload.

For example, consider driving along a road bordered by an occasional group of large trees. The sunload detected by the sunload sensor will vary whenever the trees obstruct the sunlight. The processing circuit averages the detected sunload over a period of time, so that the (insignificant) effect of the trees momentarily obstructing the sunlight does not cause any change in the ATC system operation. On the other hand, shortly after entering a long tunnel, the system will recognize the change in sunload, and the system will react accordingly.

DIAGNOSIS PROCEDURE FOR SUNLOAD SENSOR

A
B
C
D
E
F
G
H
I
ATC
K
L
M
N
O
P

TROUBLE DIAGNOSIS

< SERVICE INFORMATION >

SYMPTOM: Sunload sensor circuit is open or shorted. (25 or -25 is indicated on unified meter and A/C amp. as a result of performing self-diagnosis STEP-2.)

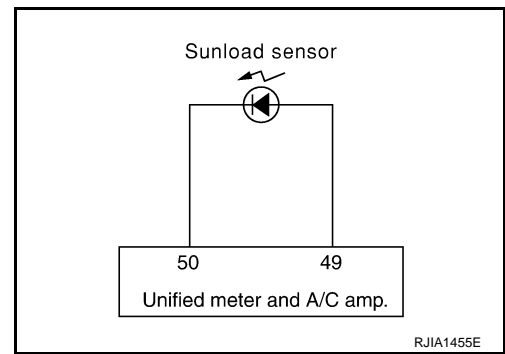

1. CHECK VOLTAGE BETWEEN SUNLOAD SENSOR AND GROUND

1. Disconnect sunload sensor connector.
2. Turn ignition switch ON.
3. Check voltage between sunload sensor harness connector M87 terminal 1 and ground.

1 – Ground : Approx. 5 V

OK or NG

- OK >> GO TO 2.
NG >> GO TO 4.

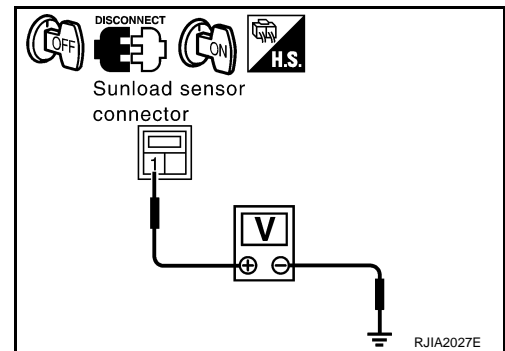

2. CHECK CIRCUIT CONTINUITY BETWEEN SUNLOAD SENSOR AND UNIFIED METER AND A/C AMP.

1. Turn ignition switch OFF.
2. Disconnect unified meter and A/C amp. connector.
3. Check continuity between sunload sensor harness connector M87 terminal 2 and unified meter and A/C amp. harness connector M57 terminal 49.

2 – 49 : Continuity should exist.

OK or NG

- OK >> GO TO 3.
NG >> Repair harness or connector.

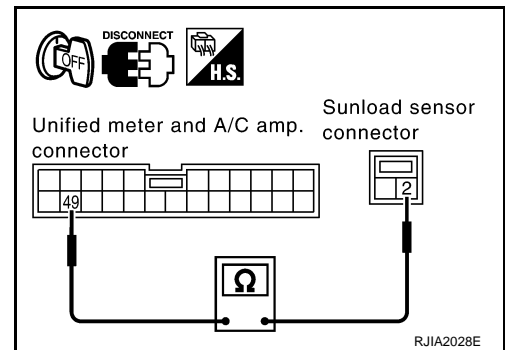

3. CHECK SUNLOAD SENSOR

1. Reconnect sunload sensor connector and unified meter and A/C amp. connector.
2. Refer to "Sunload Sensor".

OK or NG

- OK >> 1. Replace unified meter and A/C amp.
2. Go to self-diagnosis [ATC-43. "Self-Diagnosis Function"](#) and perform self-diagnosis STEP-2. Confirm that code No. 20 is displayed.
- NG >> 1. Replace sunload sensor.
2. Go to self-diagnosis [ATC-43. "Self-Diagnosis Function"](#) and perform self-diagnosis STEP-2. Confirm that code No. 20 is displayed.

4. CHECK CIRCUIT CONTINUITY BETWEEN SUNLOAD SENSOR AND UNIFIED METER AND A/C AMP.

1. Turn ignition switch OFF.
2. Disconnect unified meter and A/C amp. connector.

TROUBLE DIAGNOSIS

< SERVICE INFORMATION >

3. Check continuity between sunload sensor harness connector M87 terminal 1 and unified meter and A/C amp. harness connector M57 terminal 50.

1 – 50 : Continuity should exist.

4. Check continuity between sunload sensor harness connector M87 terminal 1 and ground.

1 – Ground : Continuity should not exist.

OK or NG

- OK >> 1. Replace unified meter and A/C amp.
2. Go to self-diagnosis [ATC-43. "Self-Diagnosis Function"](#) and perform self-diagnosis STEP-2.
Confirm that code No. 20 is displayed.
- NG >> Repair harness or connector.

COMPONENT INSPECTION

Sunload Sensor

Measure voltage between unified meter and A/C amp. harness connector M57 terminal 50 and ground.

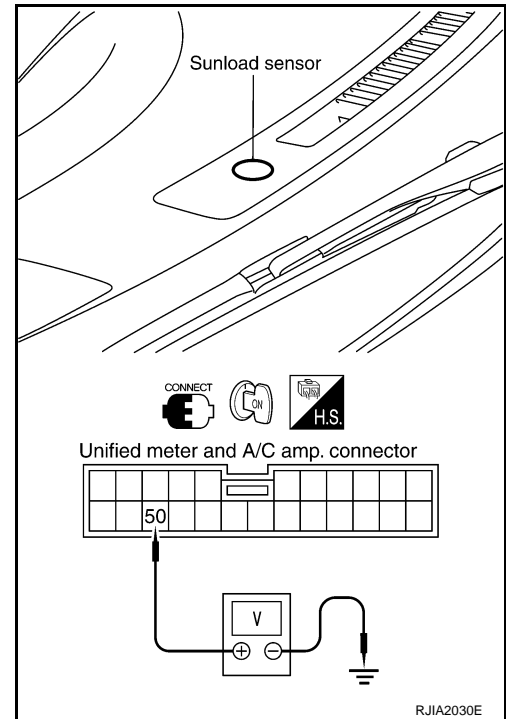
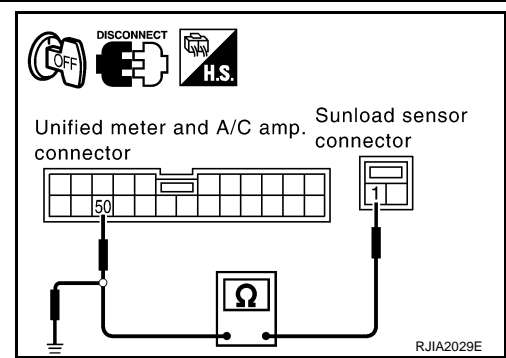

A
B
C
D
E
F
G
H
I
K
L
M
N
O
P

ATC

TROUBLE DIAGNOSIS

< SERVICE INFORMATION >

- When checking sunload sensor, select a place where sunshine directly on it.

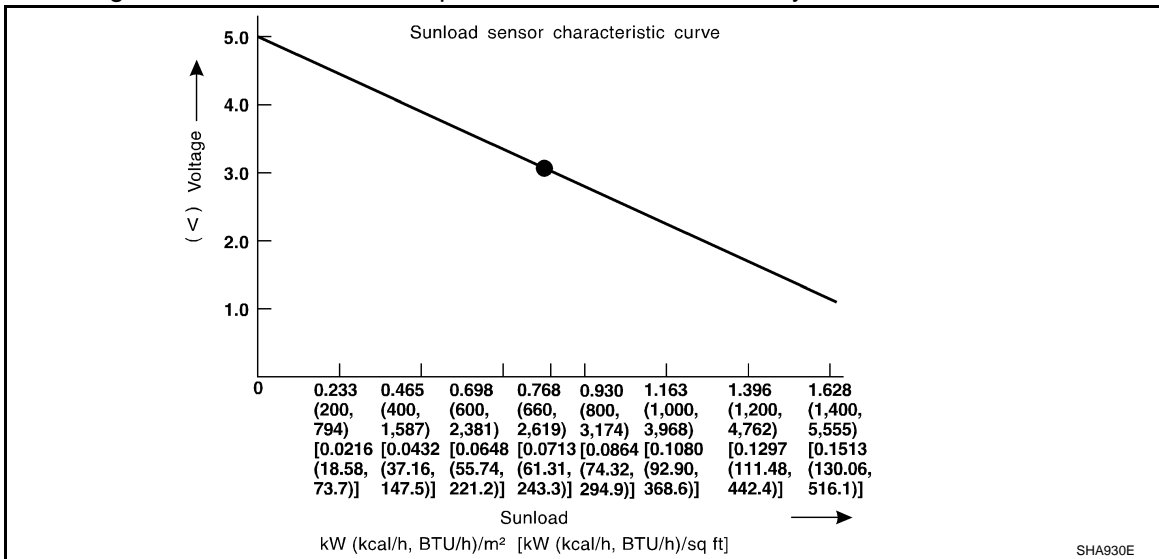

If NG, replace sunload sensor.

Intake Sensor Circuit

INFOID:000000001328199

COMPONENT DESCRIPTION

Intake Sensor

The intake sensor is located on the heater & cooling unit assembly. It converts temperature of air after it passes through the evaporator into a resistance value which is then input to the unified meter and A/C amp.

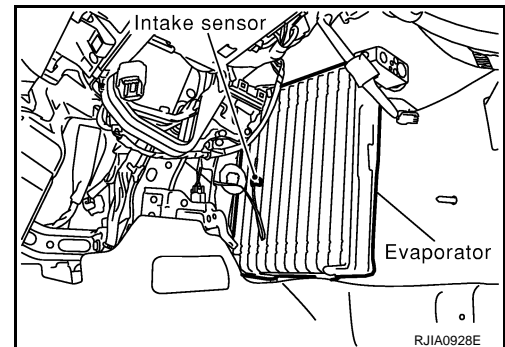

DIAGNOSIS PROCEDURE FOR INTAKE SENSOR

SYMPTOM: Intake sensor circuit is open or shorted. (24 or -24 is indicated on unified meter and A/C amp. as a result of performing self-diagnosis STEP-2.)

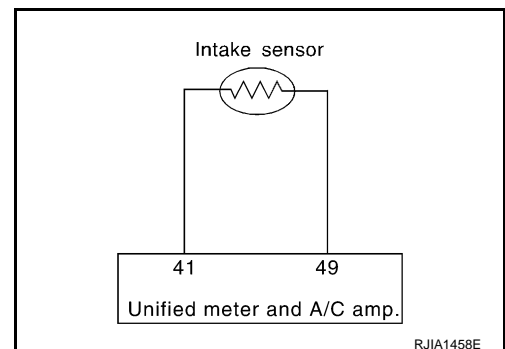

1. CHECK VOLTAGE BETWEEN INTAKE SENSOR AND GROUND

1. Disconnect intake sensor connector.
2. Turn ignition switch ON.

TROUBLE DIAGNOSIS

< SERVICE INFORMATION >

3. Check voltage between intake sensor harness connector M254 terminal 2 and ground.

2 – Ground : Approx. 5 V

OK or NG

- OK >> GO TO 2.
- NG >> GO TO 4.

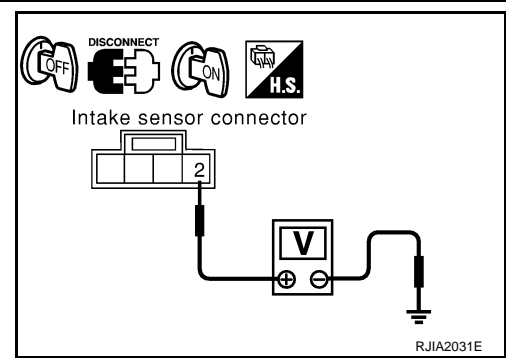

2. CHECK CIRCUIT CONTINUITY BETWEEN INTAKE SENSOR AND UNIFIED METER AND A/C AMP.

1. Turn ignition switch OFF.
2. Disconnect unified meter and A/C amp. connector.
3. Check continuity between intake sensor harness connector M254 terminal 1 and unified meter and A/C amp. harness connector M57 terminal 49.

1 – 49 : Continuity should exist.

OK or NG

- OK >> GO TO 3.
- NG >> Repair harness or connector.

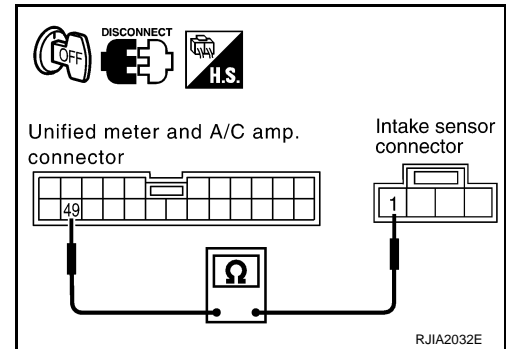

3. CHECK INTAKE SENSOR

Refer to "Intake Sensor".

OK or NG

- OK >> 1. Replace unified meter and A/C amp.
2. Go to self-diagnosis [ATC-43. "Self-Diagnosis Function"](#) and perform self-diagnosis STEP-2. Confirm that code No. 20 is displayed.
- NG >> 1. Replace intake sensor.
2. Go to self-diagnosis [ATC-43. "Self-Diagnosis Function"](#) and perform self-diagnosis STEP-2. Confirm that code No. 20 is displayed.

4. CHECK CIRCUIT CONTINUITY BETWEEN INTAKE SENSOR AND UNIFIED METER AND A/C AMP.

1. Turn ignition switch OFF.
2. Disconnect unified meter and A/C amp. connector.
3. Check continuity between intake sensor harness connector M254 terminal 2 and unified meter and A/C amp. harness connector M57 terminal 41.

2 – 41 : Continuity should exist.

4. Check continuity between intake sensor harness connector M254 terminal 2 and ground.

2 – Ground : Continuity should not exist.

OK or NG

- OK >> 1. Replace unified meter and A/C amp.
2. Go to self-diagnosis [ATC-43. "Self-Diagnosis Function"](#) and perform self-diagnosis STEP-2. Confirm that code No. 20 is displayed.
- NG >> Repair harness or connector.

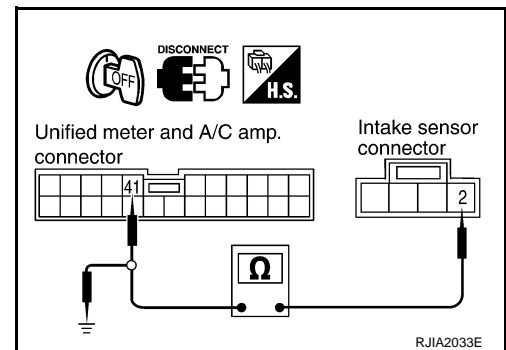

COMPONENT INSPECTION

Intake Sensor

TROUBLE DIAGNOSIS

< SERVICE INFORMATION >

After disconnecting intake sensor connector M254, measure resistance between terminals 1 and 2 at sensor side. Refer to the table below.

Temperature °C (°F)	Resistance kΩ
-15 (5)	12.34
-10 (14)	9.62
-5 (23)	7.56
0 (32)	6.00
5 (41)	4.80
10 (50)	3.87
15 (59)	3.15
20 (68)	2.57
25 (77)	2.12
30 (86)	1.76
35 (95)	1.47
40 (104)	1.23
45 (113)	1.04

If NG, replace intake sensor.

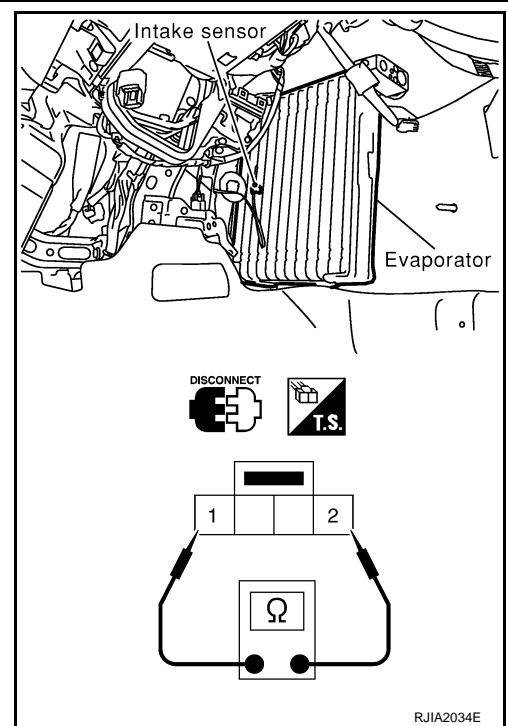

RJIA2034E

CONTROLLER

< SERVICE INFORMATION >

CONTROLLER

Removal and Installation of A/C and AV Switch

INFOID:000000001328200

REMOVAL

Refer to [AV-42. "Removal and Installation for A/C and AV Switch"](#).

INSTALLATION

Installation is basically the reverse order of removal.

A

B

C

D

E

F

G

H

I

ATC

K

L

M

N

O

P

AUTO AMP

< SERVICE INFORMATION >

AUTO AMP

Removal and Installation of Unified Meter and A/C Amp

INFOID:000000001328201

REMOVAL

1. Remove audio unit. Refer to [AV-41. "Removal and Installation of Audio Unit"](#).
2. Remove mounting screws, and then remove unified meter and A/C amp.

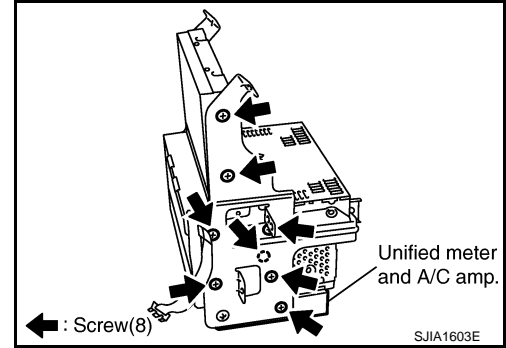

INSTALLATION

Installation is basically the reverse order of removal.

AMBIENT SENSOR

< SERVICE INFORMATION >

AMBIENT SENSOR

Removal and Installation

INFOID:000000001328202

REMOVAL

1. Remove front grille. Refer to [EI-22](#).
2. Disconnect ambient sensor connector, and then remove ambient sensor.

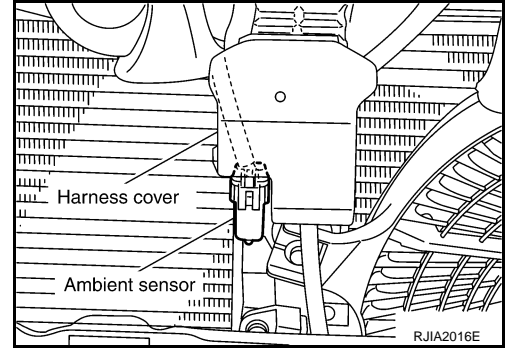

INSTALLATION

Installation is basically the reverse order of removal.

A
B
C
D
E
F
G
H
I
K
L
M
N
O
P

ATC

IN-VEHICLE SENSOR

< SERVICE INFORMATION >

IN-VEHICLE SENSOR

Removal and Installation

INFOID:000000001328203

REMOVAL

1. Remove instrument driver lower panel. Refer to [IP-10](#).
2. Remove mounting screw, and then remove in-vehicle sensor.

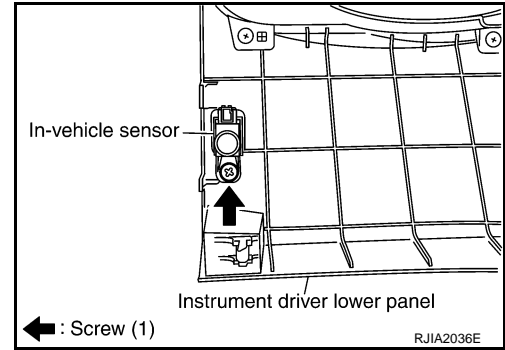

INSTALLATION

Installation is basically the reverse order of removal.

SUNLOAD SENSOR

< SERVICE INFORMATION >

SUNLOAD SENSOR

Removal and Installation

INFOID:000000001328204

REMOVAL

1. Remove front defroster grille (RH). Refer to [IP-10](#).
2. Disconnect sunload sensor connector, and then remove the sunload sensor.

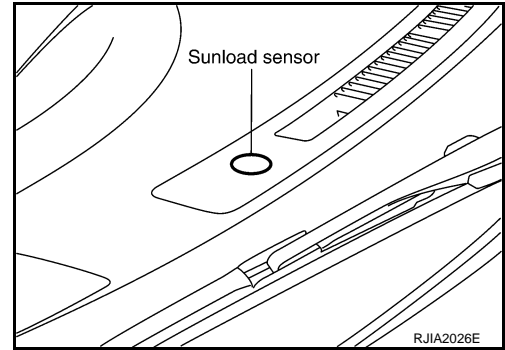

INSTALLATION

Installation is basically the reverse order of removal.

A
B
C
D
E
F
G
H
I
K
L
M
N
O
P

ATC

INTAKE SENSOR

< SERVICE INFORMATION >

INTAKE SENSOR

Removal and Installation

INFOID:000000001328205

REMOVAL

1. Remove low-pressure pipe 2 and high-pressure pipe 3. Refer to [ATC-133. "Removal and Installation of Low-Pressure Pipe 2 and High-pressure Pipe 3"](#).

CAUTION:

Cap or wrap the joint of evaporator, low-pressure pipe 1 and high-pressure pipe 2 with suitable material such as vinyl tape to avoid the entry of air.

2. Slide evaporator to passenger side, and then remove intake sensor.

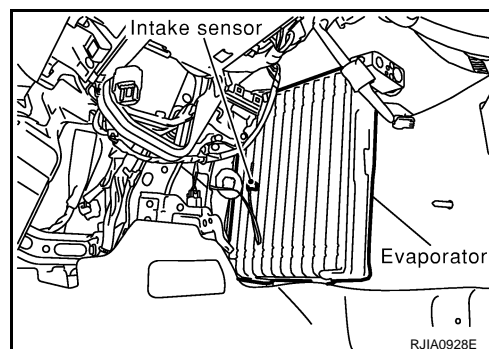

INSTALLATION

Installation is basically the reverse order of removal.

CAUTION:

- Replace O-rings of low-pressure pipe 1, 2 and high-pressure pipe 2, 3 with new ones, and then apply compressor oil to it when installing it.
- Mark the mounting position of intake sensor bracket prior to removal so that the reinstalled sensor can be located in the same position.
- Female-side piping connection is thin and easy to deform. Slowly insert the male-side piping straight in axial direction.
- Insert piping securely until a click is heard.
- After piping connection is completed, pull male-side piping by hand to make sure that connection does not come loose.
- When recharging refrigerant, check for leaks.

BLOWER UNIT

< SERVICE INFORMATION >

BLOWER UNIT

Removal and Installation

INFOID:000000001328206

REMOVAL

1. Remove instrument passenger lower panel. Refer to [IP-10](#).
2. Remove mounting nut, and then remove ECM with bracket attached.
3. Disconnect intake door motor connector and blower fan motor connector.
4. Remove harness clip from blower unit.
5. Remove mounting bolt and screws from blower unit.

CAUTION:

Move blower unit rightward, and remove locating pin (1 part) and joint. Then remove blower unit downward.

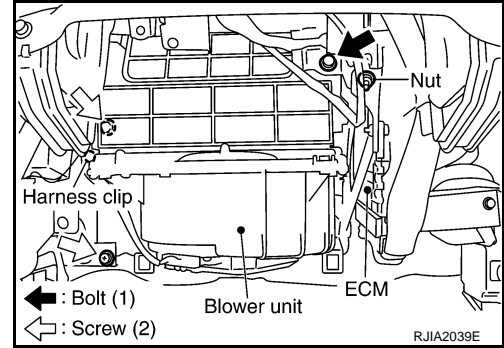

6. Remove blower unit.

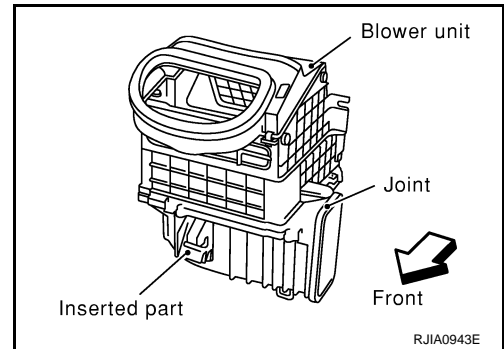

INSTALLATION

Installation is basically the reverse order of removal.

CAUTION:

Make sure locating pin (1 part) and joint are securely inserted.

A
B
C
D
E
F
G
H
I
K
L
M
N
O
P

ATC

BLOWER UNIT

< SERVICE INFORMATION >

Disassembly and Assembly

INFOID:000000001328207

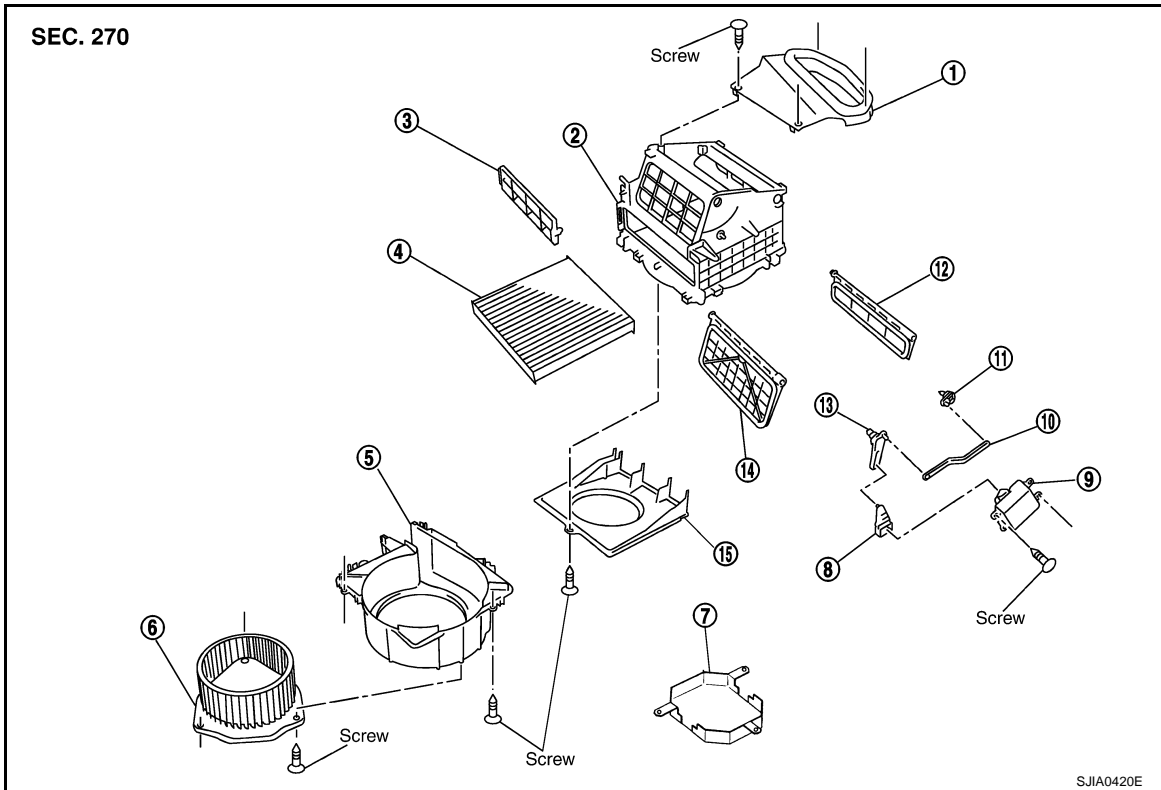

- | | | |
|-------------------------|-------------------------|--------------------------|
| 1. Adapter | 2. Intake upper case | 3. Filter cover |
| 4. In-cabin microfilter | 5. Intake lower case | 6. Blower motor assembly |
| 7. Motor cover | 8. Intake door lever 2 | 9. Intake door motor |
| 10. Intake door link | 11. Intake door lever 3 | 12. Intake door 2 |
| 13. Intake door lever 1 | 14. Intake door 1 | 15. Intake bell mouth |

BLOWER MOTOR

< SERVICE INFORMATION >

BLOWER MOTOR

Removal and Installation

INFOID:000000001328208

REMOVAL

1. Remove instrument lower cover. Refer to [IP-10](#).
2. Disconnect blower motor connector.
3. Remove mounting screws, and then remove blower motor.

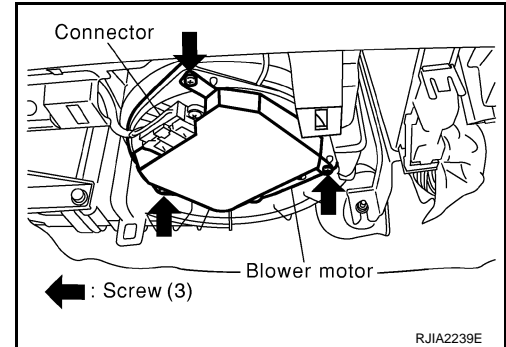

INSTALLATION

Installation is basically the reverse order of removal.

A
B
C
D
E
F
G
H
I
K
L
M
N
O
P

ATC

INTAKE DOOR MOTOR

< SERVICE INFORMATION >

INTAKE DOOR MOTOR

Removal and Installation

INFOID:000000001328209

REMOVAL

1. Remove blower unit. Refer to [ATC-103](#).
2. Remove mounting screws, and then remove intake door motor from blower unit.

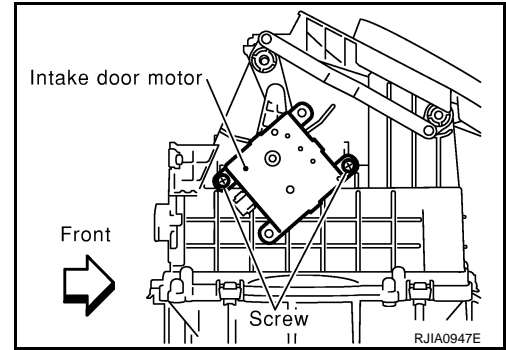

INSTALLATION

Installation is basically the reverse order of removal.

IN-CABIN MICROFILTER

< SERVICE INFORMATION >

IN-CABIN MICROFILTER

Removal and Installation

INFOID:000000001328210

FUNCTION

Air inside passenger compartment is kept clean at either recirculation or fresh mode by installing in-cabin microfilter into blower unit.

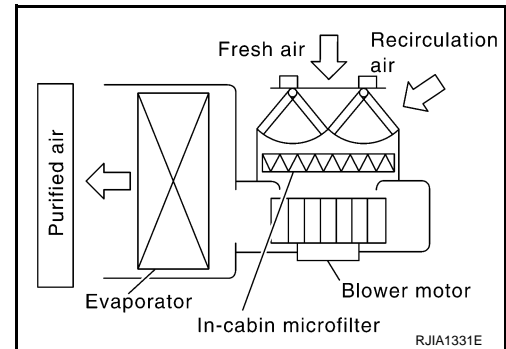

REPLACEMENT TIMING

Replace in-cabin microfilter.

Refer to [MA-5, "Schedule 1"](#) in Schedule 1 and [MA-7, "Schedule 2"](#) in Schedule 2.

When replacing filter, affix a caution label inside the glove box.

REPLACEMENT PROCEDURES

1. Remove instrument passenger lower panel. Refer to [IP-10](#).
2. Remove filter cover, and then remove in-cabin microfilter.
3. Take out in-cabin microfilter from blower unit.
4. Replace with new one and reinstall on blower unit.
5. Reinstall instrument passenger lower panel.

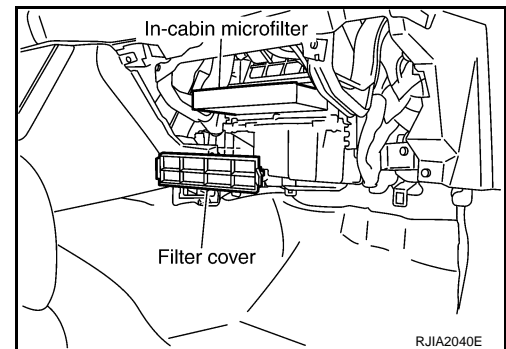

A
B
C
D
E
F
G
H
I
K
L
M
N
O
P

ATC

HEATER & COOLING UNIT ASSEMBLY

< SERVICE INFORMATION >

HEATER & COOLING UNIT ASSEMBLY

Removal and Installation

INFOID:000000001328211

REMOVAL

1. Use a refrigerant collecting equipment (for HFC-134a) to discharge the refrigerant.
2. Drain coolant from cooling system. Refer to [CO-10, "Changing Engine Coolant"](#) (VQ35DE) or [CO-37, "Changing Engine Coolant"](#) (VK45DE).
3. Remove cowl top cover. Refer to [EI-23](#).
4. Remove high-pressure pipe 2 mounting clip.
5. Remove low-pressure flexible hose bracket mounting bolt. Refer to [ATC-128, "Removal and Installation of Low-Pressure Flexible Hose"](#).

6. Disconnect low-pressure pipe 1 and high-pressure pipe 2 from evaporator.

- a. Set a disconnecter [high-pressure side (SST: 9253089908), low-pressure side (SST: 9253089916)] on A/C piping.
- b. Slide a disconnecter toward vehicle front until it clicks.
- c. Slide A/C piping toward vehicle front and disconnect it.

CAUTION:

Cap or wrap the joint of low-pressure pipe 1, 2 and high-pressure pipe 2, 3 with suitable material such as vinyl tape to avoid the entry of air.

7. Remove electric throttle control actuator (VQ35DE). Refer to [EM-19](#).

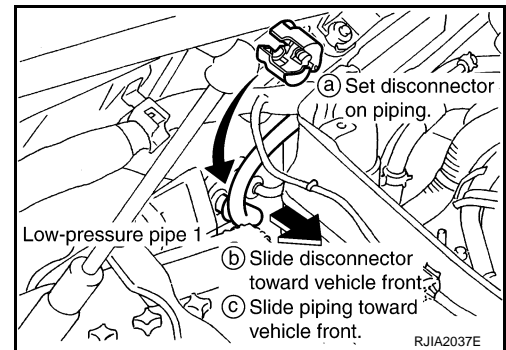

8. Disconnect two heater hoses from heater core.

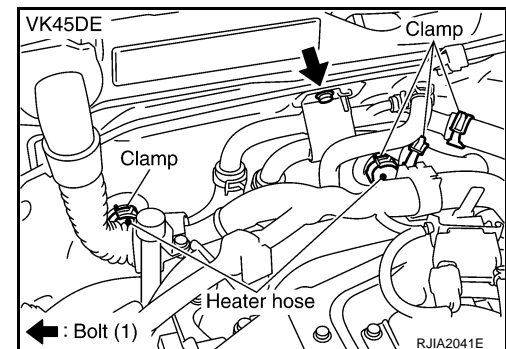
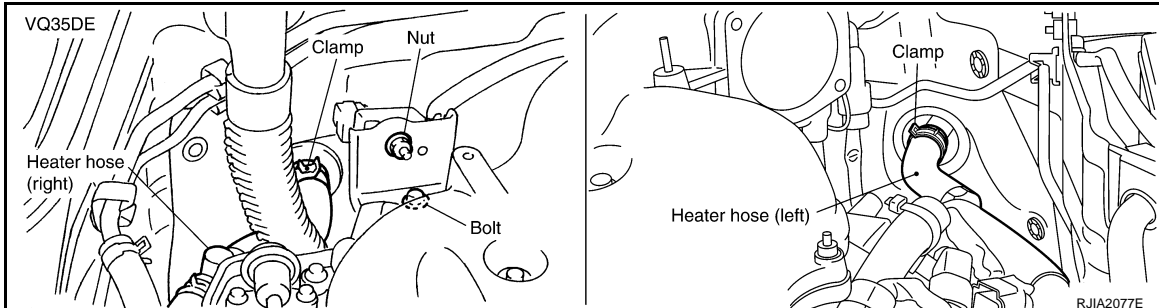

9. Remove instrument panel and pad. Refer to [IP-10](#).
10. Remove blower unit. Refer to [ATC-103](#).

HEATER & COOLING UNIT ASSEMBLY

< SERVICE INFORMATION >

11. Remove mounting nuts and bolts, and then remove instrument stays (left and right side).

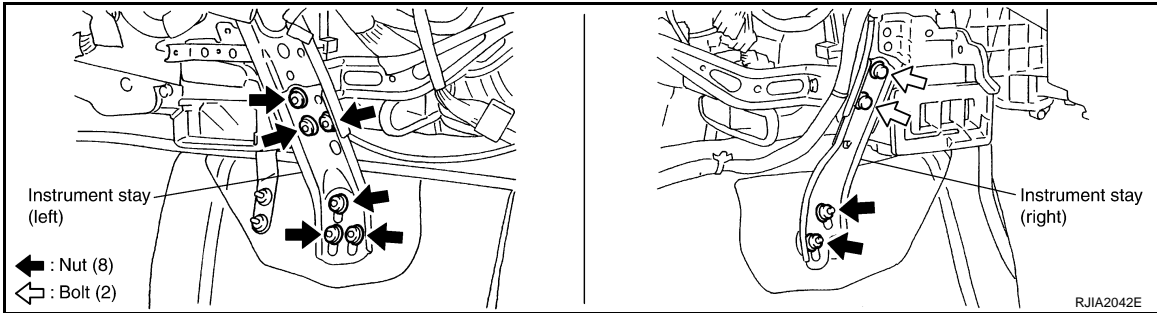

12. Remove mounting bolts from heater & cooling unit assembly.

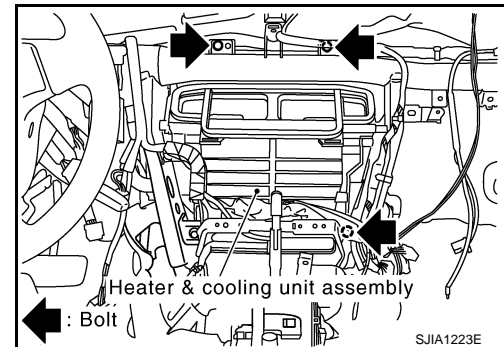

13. Disconnect drain hose.
14. Remove center and side ventilator ducts, defroster nozzle and side defroster ducts. Refer to [ATC-116](#), "[Removal and Installation](#)".
15. Remove steering column mounting bolts and nut.

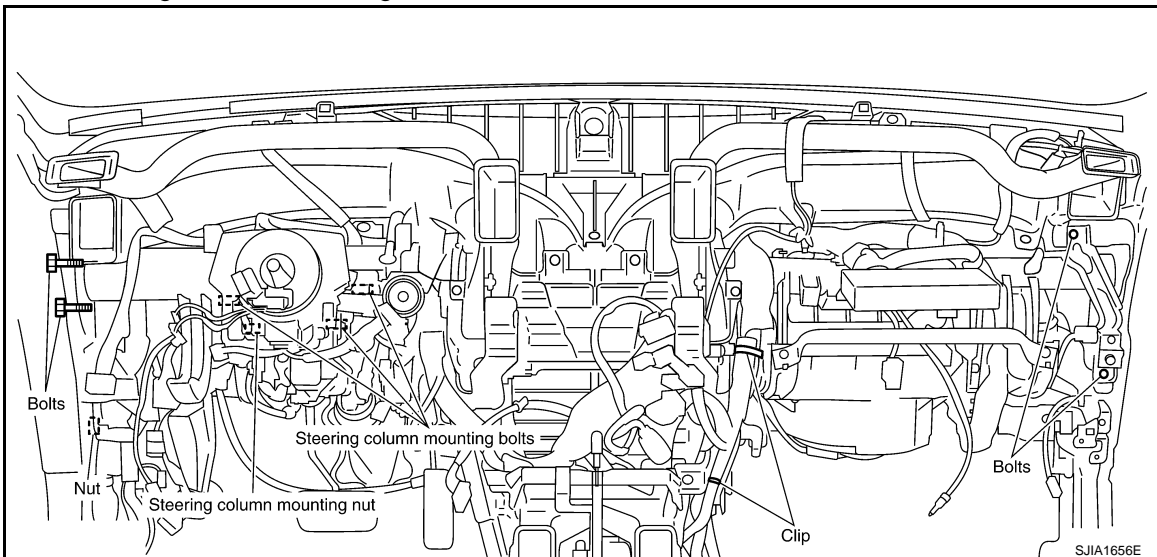

16. Remove steering member mounting bolts, nut and harness clips.
17. Remove steering member, and then remove heater & cooling unit assembly.

INSTALLATION

Installation is basically the reverse order of removal.

CAUTION:

- Replace O-rings of low-pressure pipe 1 and high-pressure pipe 2 with new ones, and then apply compressor oil to it when installing it.
- Female-side piping connection is thin and easy to deform. Slowly insert the male-side piping straight in axial direction.
- Insert piping securely until a click is heard.
- After piping connection is completed, pull male-side piping by hand to make sure that connection does not come loose.
- When recharging refrigerant, check for leaks.

A
B
C
D
E
F
G
H
I
K
L
M
N
O
P

ATC

HEATER & COOLING UNIT ASSEMBLY

< SERVICE INFORMATION >

NOTE:

- When filling radiator with coolant, refer to [CO-10, "Changing Engine Coolant"](#) (VQ35DE) or [CO-37, "Changing Engine Coolant"](#) (VK45DE).
- Recharge the refrigerant.

Heater & cooling unit assembly mounting bolt



: 6.8 N·m (0.69 kg-m, 60 in-lb)

Steering member mounting nut and bolt



: 12 N·m (1.2 kg-m, 9 ft-lb)

Steering column mounting nut and bolt



: 16.7 N·m (1.7 kg-m, 12 ft-lb)

HEATER & COOLING UNIT ASSEMBLY

< SERVICE INFORMATION >

Disassembly and Assembly

INFOID:000000001328212

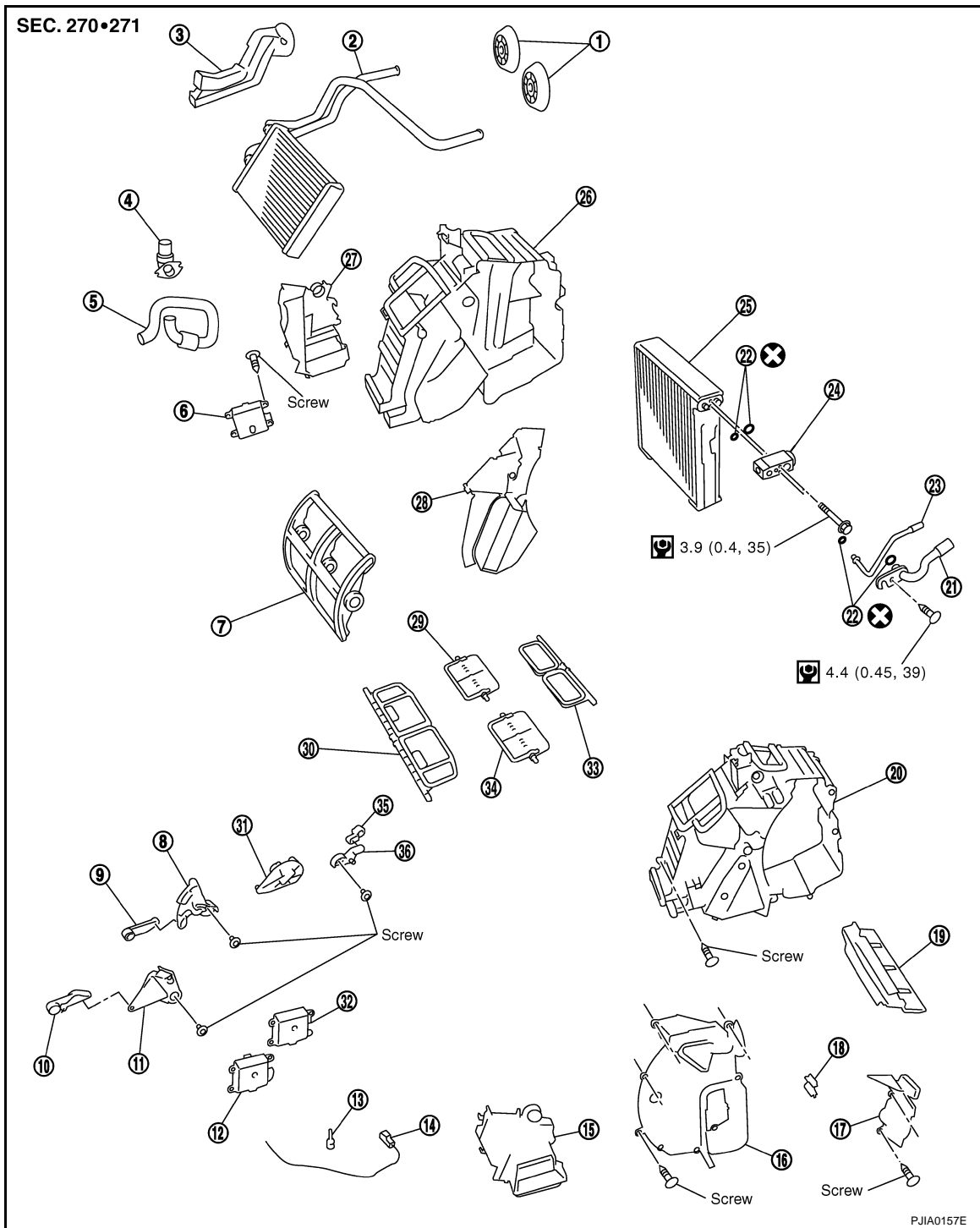

- | | | |
|------------------------------|------------------------------|---|
| 1. Heater pipe grommet | 2. Heater core | 3. Heater pipe cover |
| 4. Aspirator | 5. Aspirator hose | 6. Air mix door motor (driver side) |
| 7. Air mix door (slide door) | 8. Max. cool door link | 9. Max. cool door lever |
| 10. Ventilator door lever | 11. Ventilator door link | 12. Air mix door motor (passenger side) |
| 13. Intake sensor bracket | 14. Intake sensor | 15. Foot duct (right) |
| 16. Evaporator cover | 17. Evaporator cover adaptor | 18. Heater pipe bracket |
| 19. Insulator | 20. Heater case (right) | 21. Low-pressure pipe 2 |
| 22. O-ring | 23. High-pressure pipe 3 | 24. Expansion valve |

A
B
C
D
E
F
G
H
I
ATC
K
L
M
N
O
P

HEATER & COOLING UNIT ASSEMBLY

< SERVICE INFORMATION >

- | | | |
|----------------------------|---------------------------|-------------------------|
| 25. Evaporator | 26. Heater case (left) | 27. Foot duct (left) |
| 28. Center case | 29. Max. cool door (left) | 30. Ventilator door |
| 31. Side link | 32. Mode door motor | 33. Defroster door |
| 34. Max. cool door (right) | 35. Defroster door lever | 36. Defroster door link |



: N·m (kg-m, in-lb)



: Always replace after every disassembly.

MODE DOOR MOTOR

< SERVICE INFORMATION >

MODE DOOR MOTOR

Removal and Installation

INFOID:000000001328213

REMOVAL

1. Remove blower unit. Refer to [ATC-103](#).
2. Remove mounting screws, and then remove mode door motor.
3. Disconnect mode door motor connector.

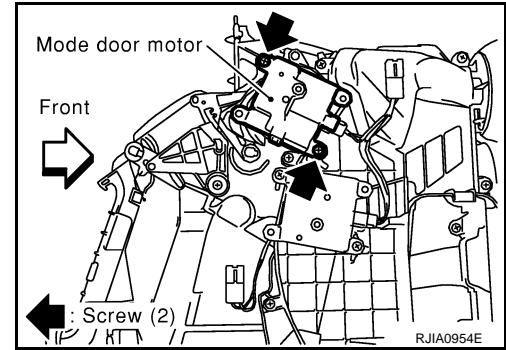

INSTALLATION

Installation is basically the reverse order of removal.

A
B
C
D
E
F
G
H
I
K
L
M
N
O
P

ATC

AIR MIX DOOR MOTOR

< SERVICE INFORMATION >

AIR MIX DOOR MOTOR

Removal and Installation

INFOID:000000001328214

REMOVAL

Driver Side

1. Set the temperature control switch (driver side) at 18°C (60°F), and then disconnect the battery cable from the negative terminal.
2. Remove instrument driver lower panel. Refer to [IP-10](#).
3. Remove mounting screws, and then remove air mix door motor.
4. Disconnect air mix door motor connector.

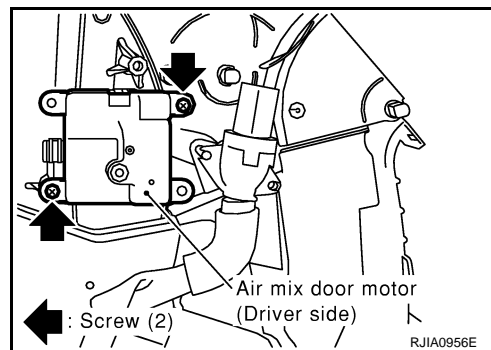

Passenger Side

1. Set the temperature control switch (passenger side) at 18°C (60°F), and then disconnect the battery cable from the negative terminal.
2. Remove blower unit. Refer to [ATC-103](#).
3. Remove mounting screws, and then remove air mix door motor.
4. Disconnect air mix door motor connector.

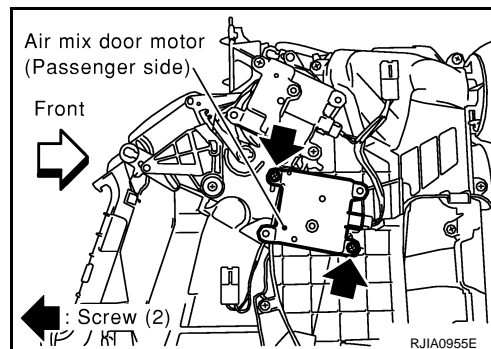

INSTALLATION

Installation is basically the reverse order of removal.

HEATER CORE

< SERVICE INFORMATION >

HEATER CORE

Removal and Installation

INFOID:000000001328215

REMOVAL

1. Remove heater & cooling unit assembly. Refer to [ATC-108](#).
2. Remove foot duct (left). Refer to [ATC-116, "Removal and Installation"](#).
3. Remove mounting screws, and then remove heater pipe cover.
4. Remove heater pipe bracket.
5. Slide heater core (shown in the figure) to driver side.

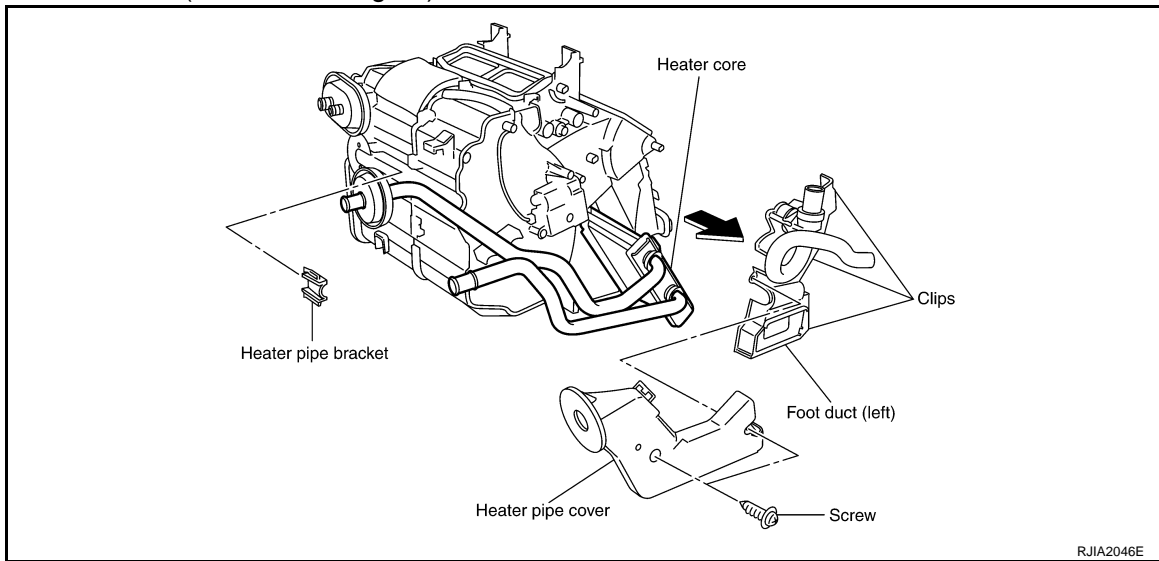

INSTALLATION

Installation is basically the reverse order of removal.

A
B
C
D
E
F
G
H
I
K
L
M
N
O
P

ATC

DUCTS AND GRILLES

< SERVICE INFORMATION >

DUCTS AND GRILLES

Removal and Installation

INFOID:000000001328216

COMPONENT LAYOUT

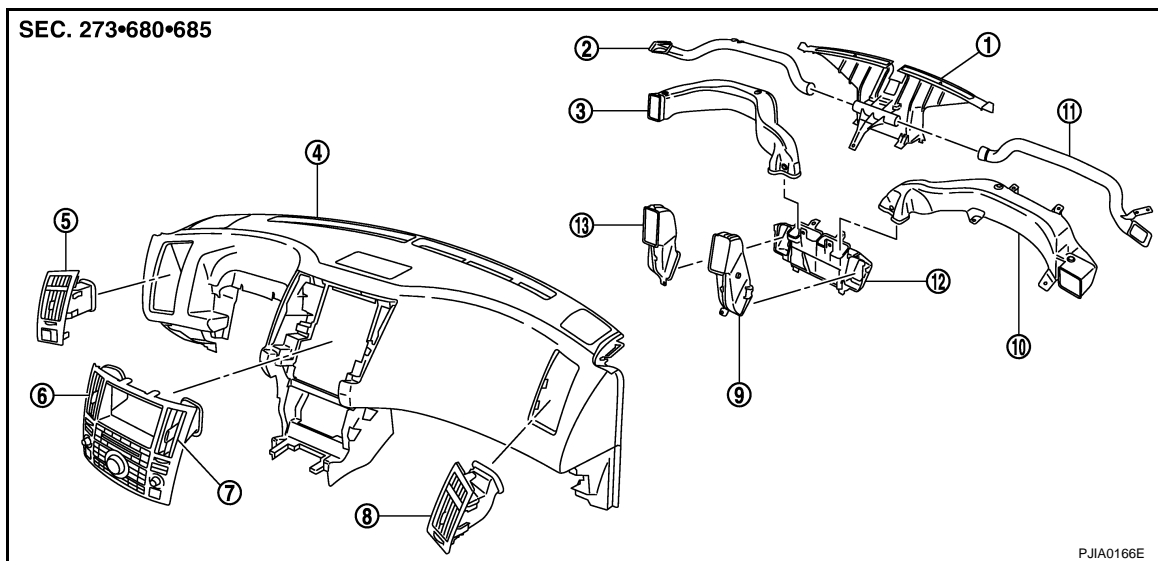

- | | | |
|-------------------------------------|---------------------------------|------------------------------------|
| 1. Defroster nozzle | 2. Side defroster duct (left) | 3. Side ventilator duct (left) |
| 4. Instrument panel | 5. Side ventilation (left) | 6. Center ventilator grille (left) |
| 7. Center ventilator grille (right) | 8. Side ventilation (right) | 9. Center ventilator duct (right) |
| 10. Side ventilator duct (right) | 11. Side defroster duct (right) | 12. Center ventilator duct |
| 13. Center ventilator duct (left) | | |

REMOVAL

Removal of Center Ventilator Grilles

1. Remove cluster lid C. Refer to [IP-10](#).
2. Remove mounting screws, and then remove center ventilator grilles.

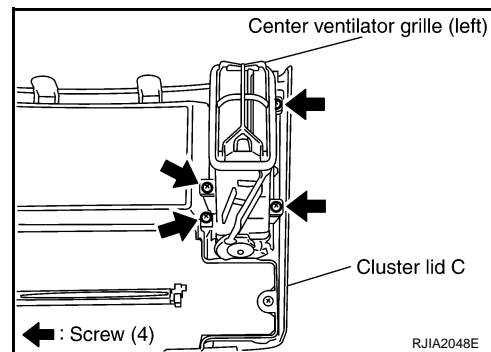

Removal of Side Ventilation

Remove side ventilation. Refer to [IP-10](#).

Removal of Rear Ventilator Grilles

1. Remove center pillar lower garnish. Refer to [IP-10](#).

DUCTS AND GRILLES

< SERVICE INFORMATION >

2. Remove mounting clips, and then remove rear ventilator grilles.

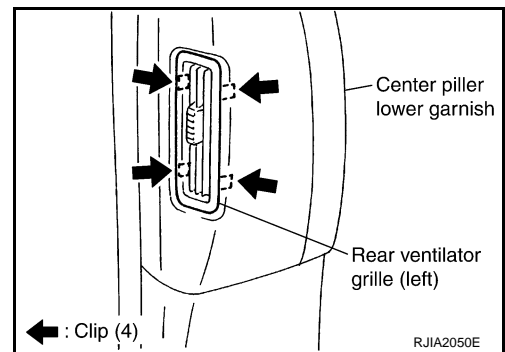

Removal of Defroster Nozzle, Ducts and Ventilator Ducts

1. Remove instrument panel and pad. Refer to [IP-10](#).
2. Remove mounting screws, and then remove side defroster ducts.

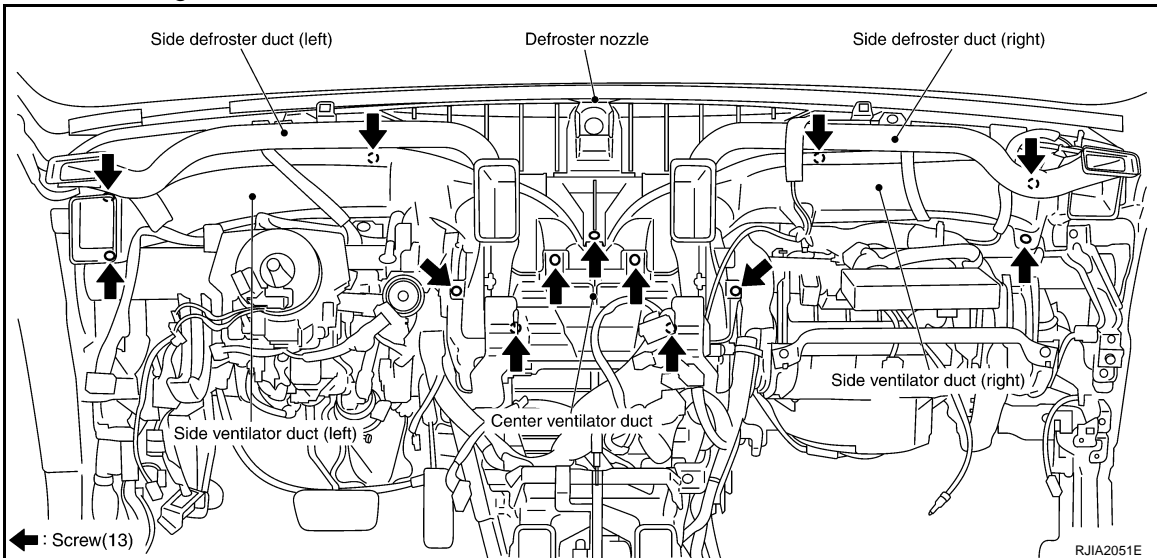

3. Remove mounting screws, and then remove defroster nozzle.
4. Remove mounting screws, and then remove side ventilator ducts (right and left).
5. Remove mounting screws, and then remove center ventilator duct.

Removal of Rear Ventilator Ducts

1. Remove center console. Refer to [IP-10](#).
2. Slide rear ventilator duct 2 toward vehicle front, and then remove it.

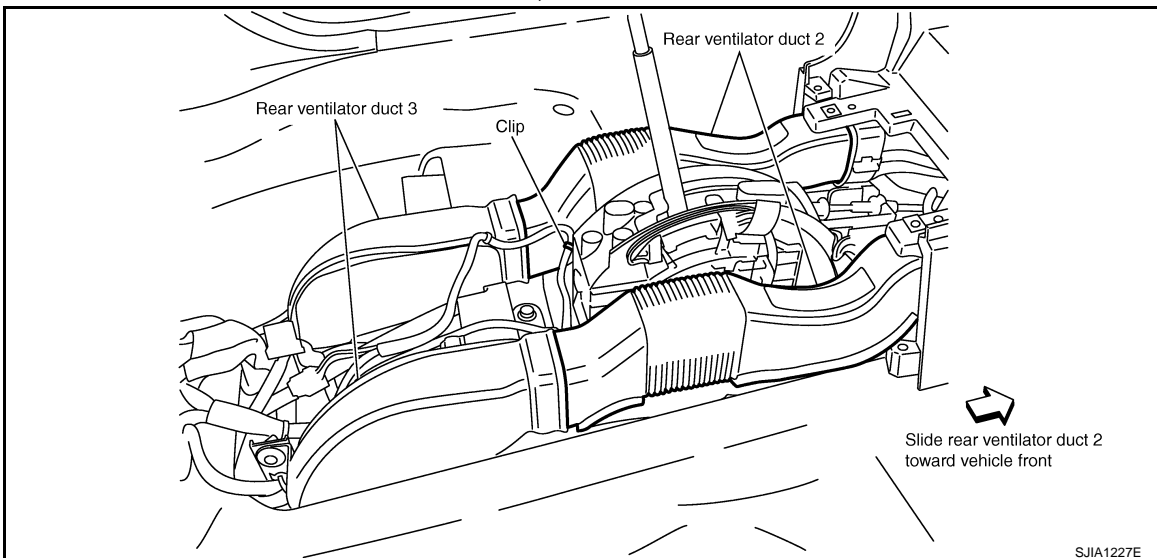

3. Remove floor carpet. Refer to [EI-41](#).

DUCTS AND GRILLES

< SERVICE INFORMATION >

4. Remove mounting clips, and then remove rear ventilator duct 3.

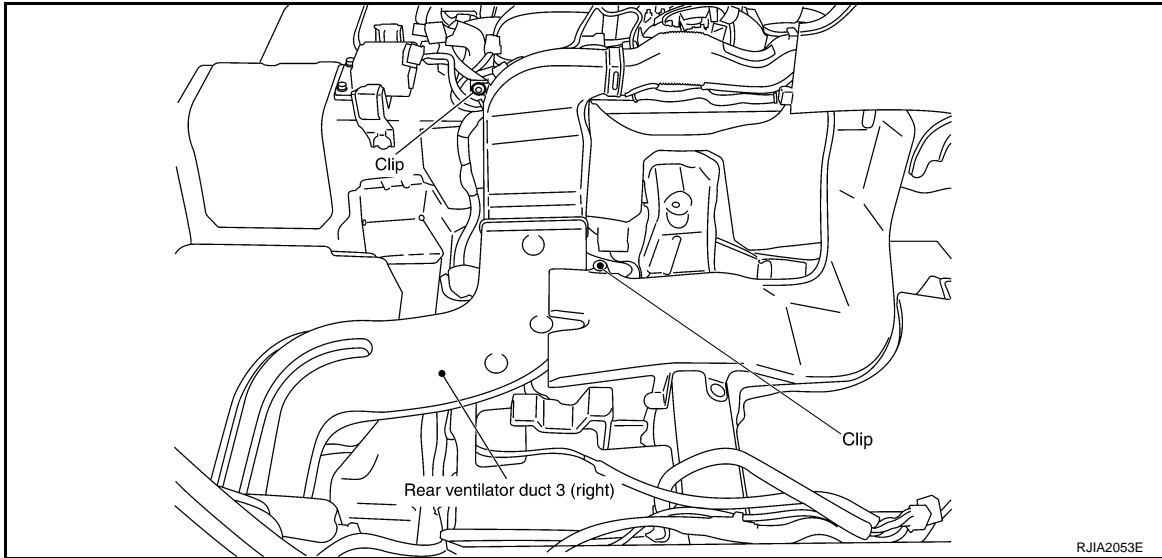

5. Remove instrument panel and pad. Refer to [IP-10](#).
6. Remove rear ventilator duct 1 with center floor duct attached.
7. Remove rear ventilator duct 1 from center floor duct.

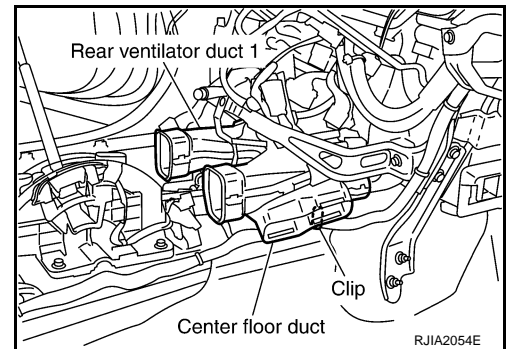

Removal of Foot Ducts

1. Remove heater & cooling unit assembly. Refer to [ATC-108](#).
2. Remove mounting screws, and then remove air mix door motor (right), mode door motor, evaporator cover and foot duct (right).
3. Remove foot duct (left).

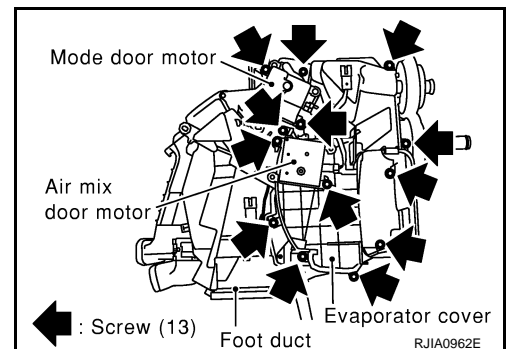

Removal of Floor Ducts

1. Remove floor carpet. Refer to [EI-41](#).
2. Remove mounting clips, and then remove side floor ducts.
3. Remove instrument panel and pad. Refer to [IP-10](#).

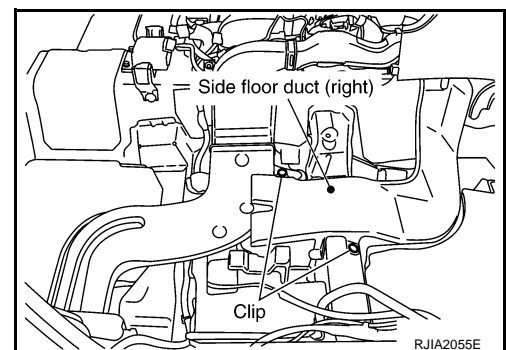

DUCTS AND GRILLES

< SERVICE INFORMATION >

4. Remove mounting clip, and then remove center floor duct with rear ventilator duct 1 attached.
5. Remove center floor duct from rear ventilator duct 1.

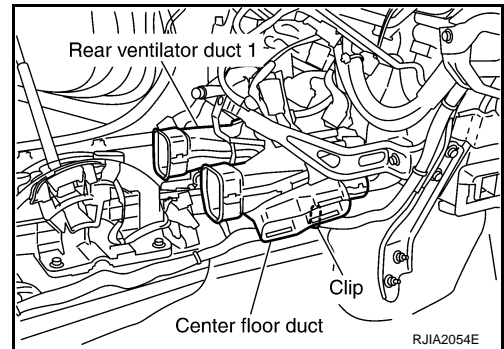

INSTALLATION

Installation is basically the reverse order of removal.

A
B
C
D
E
F
G
H
I
K
L
M
N
O
P

ATC

REFRIGERANT LINES

< SERVICE INFORMATION >

REFRIGERANT LINES

HFC-134a (R-134a) Service Procedure

INFOID:000000001328217

SETTING OF SERVICE TOOLS AND EQUIPMENT

Discharging Refrigerant

WARNING:

Avoid breathing A/C refrigerant and lubricant vapor or mist. Exposure may irritate eyes, nose and throat. Remove HFC-134a (R-134a) from A/C system using certified service equipment meeting requirements of SAE J-2210 [HFC-134a (R-134a) recycling equipment] or J-2209 [HFC-134a (R-134a) recovery equipment]. If accidental system discharge occurs, ventilate work area before resuming service. Additional health and safety information may be obtained from refrigerant and lubricant manufacturers.

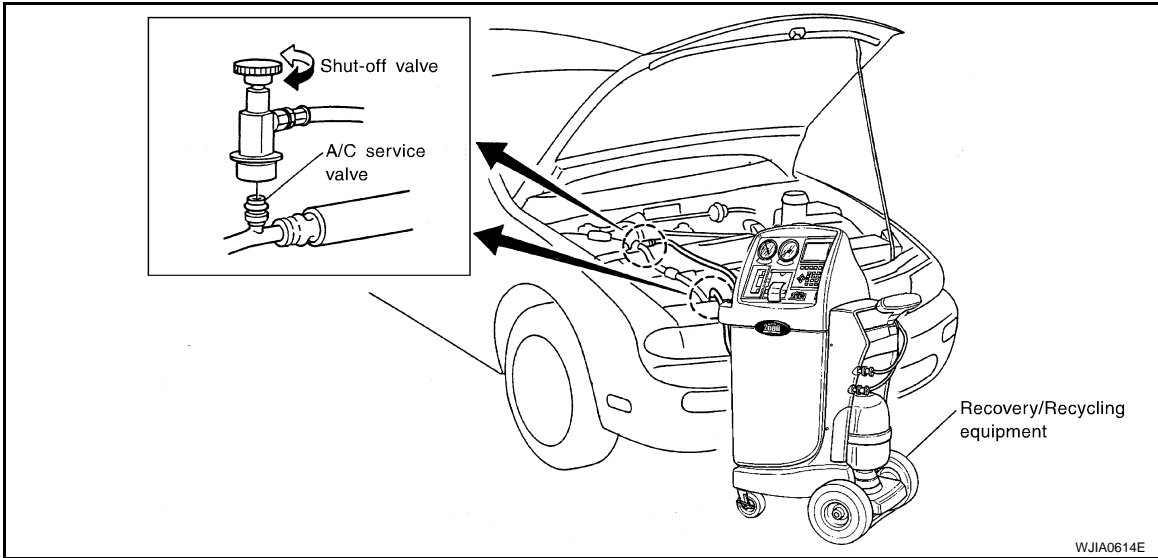

Evacuating System and Charging Refrigerant

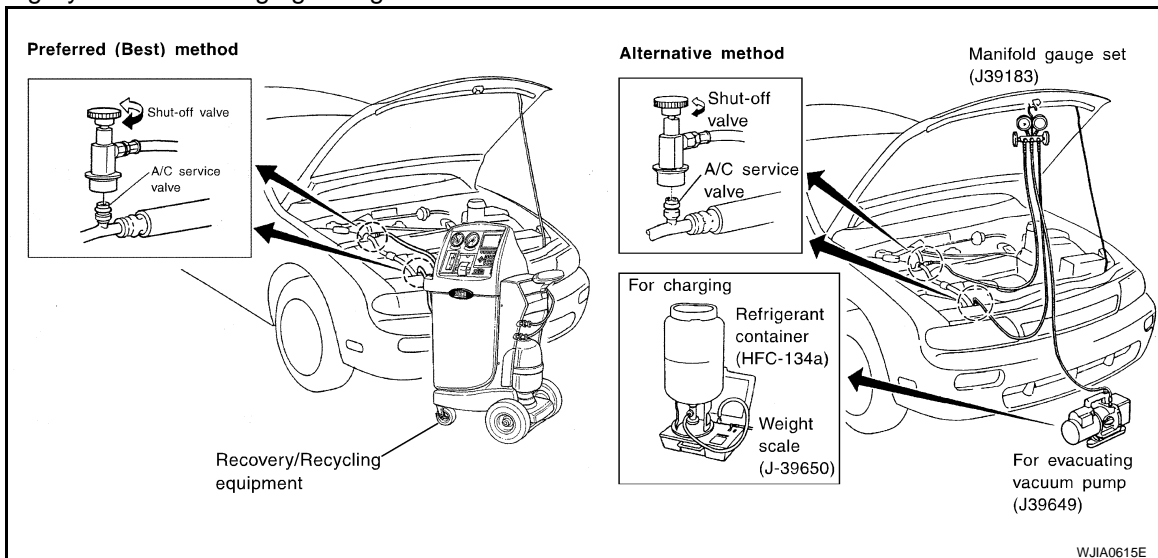

REFRIGERANT LINES

< SERVICE INFORMATION >

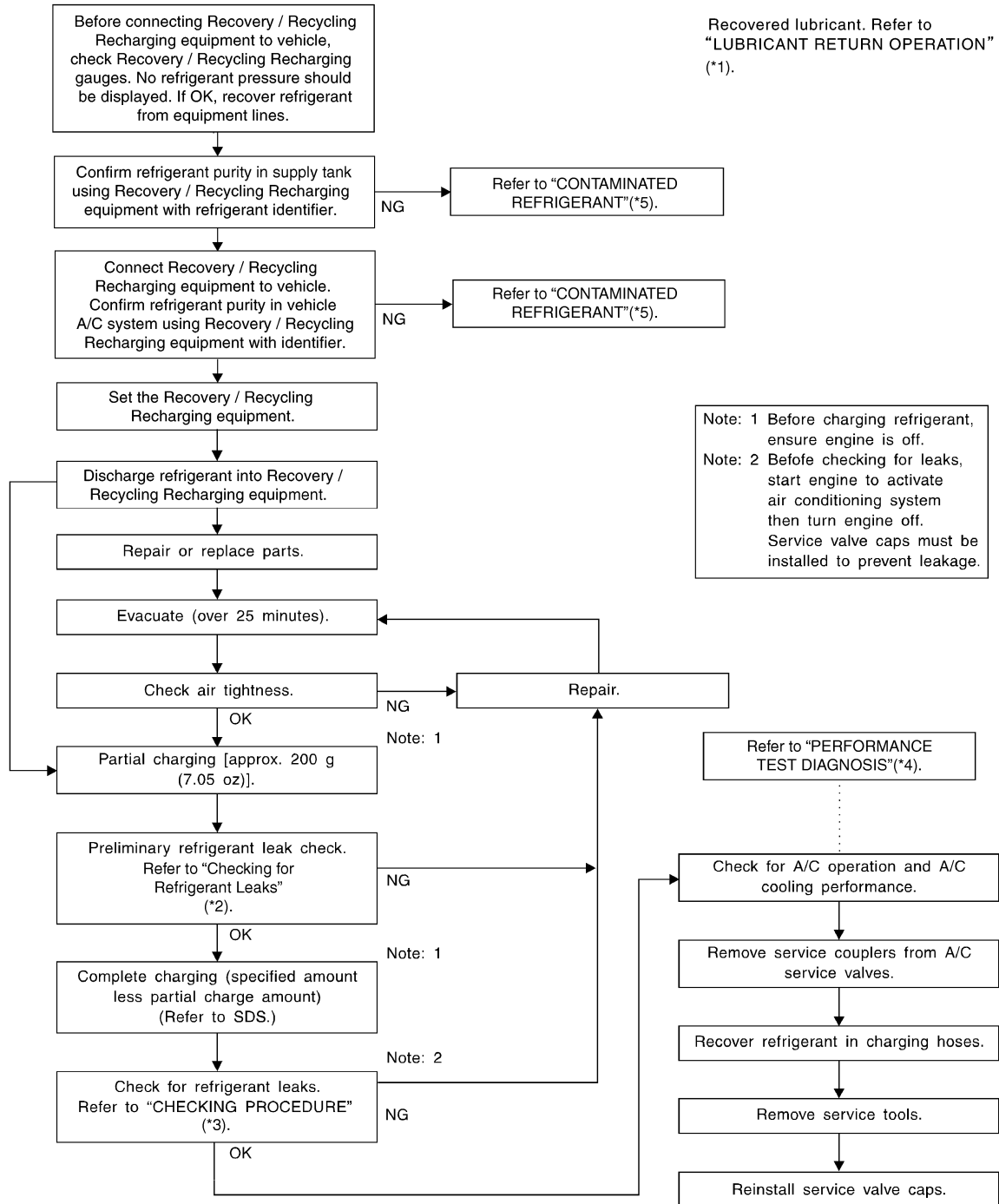

SJIA1275E

*1 [ATC-22, "Maintenance of Lubricant Quantity in Compressor"](#)

*2 [ATC-138, "Checking of Refrigerant Leaks"](#)

*3 [ATC-139, "Electrical Leak Detector"](#)

*4 [ATC-75, "Insufficient Cooling"](#)

*5 [ATC-4, "Precaution for Working with HFC-134a \(R-134a\)"](#)

Component

Refer to [ATC-5, "Precaution for Refrigerant Connection"](#).

INFOID:000000001328218

REFRIGERANT LINES

< SERVICE INFORMATION >

VQ35DE

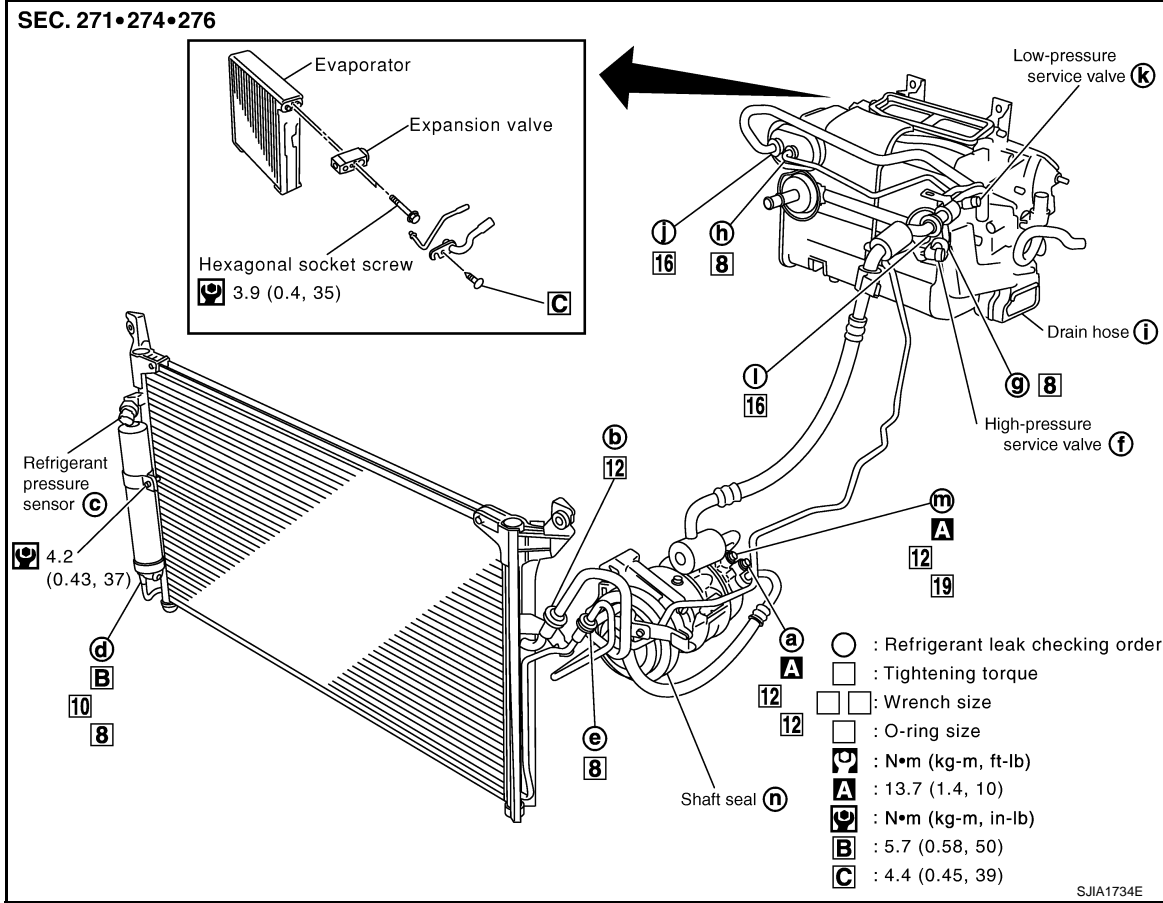

REFRIGERANT LINES

< SERVICE INFORMATION >

VK45DE

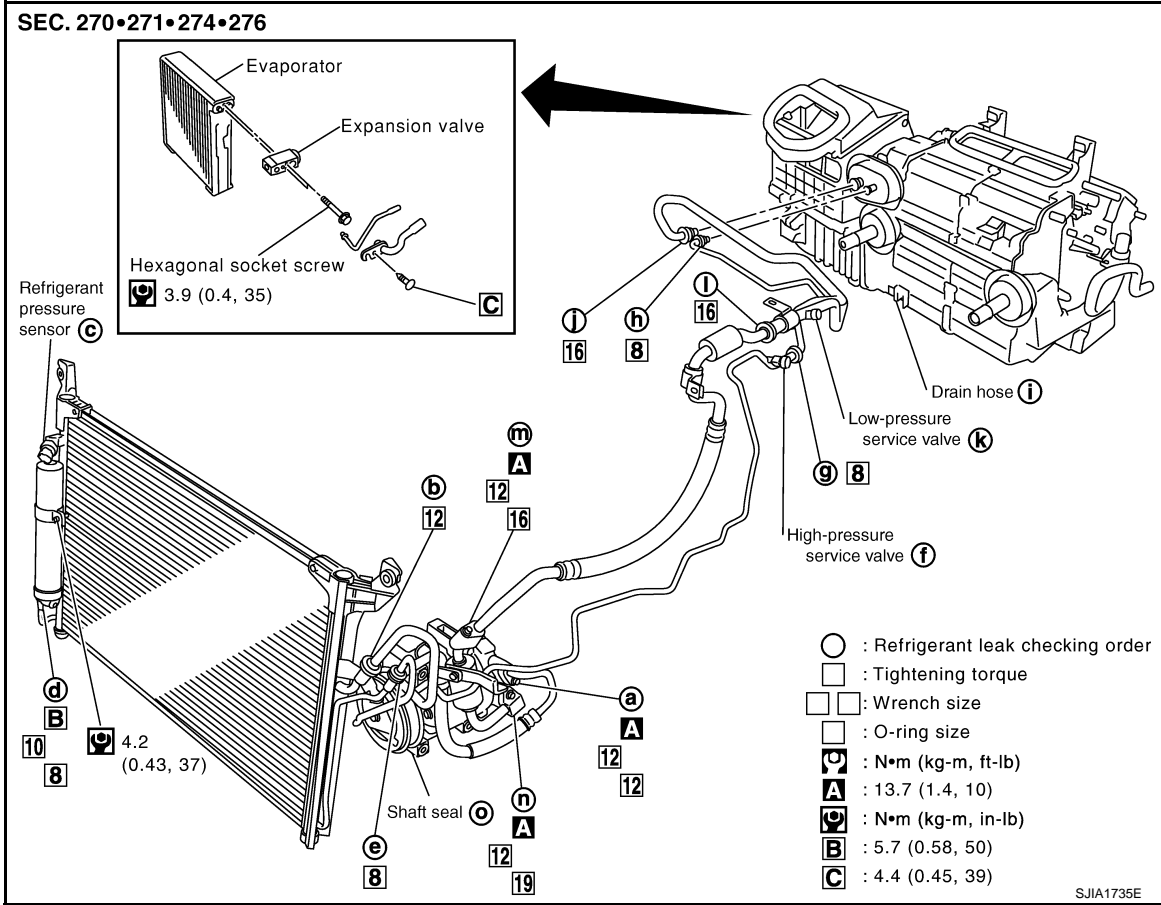

Removal and Installation of Compressor

INFOID:000000001328219

REMOVAL

VQ35DE

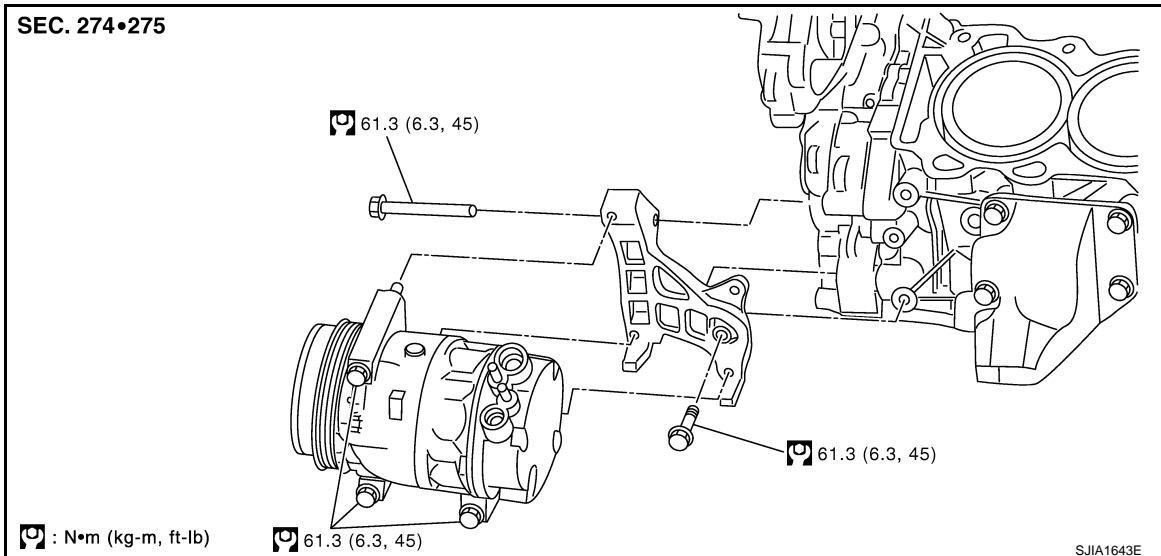

REFRIGERANT LINES

< SERVICE INFORMATION >

VK45DE

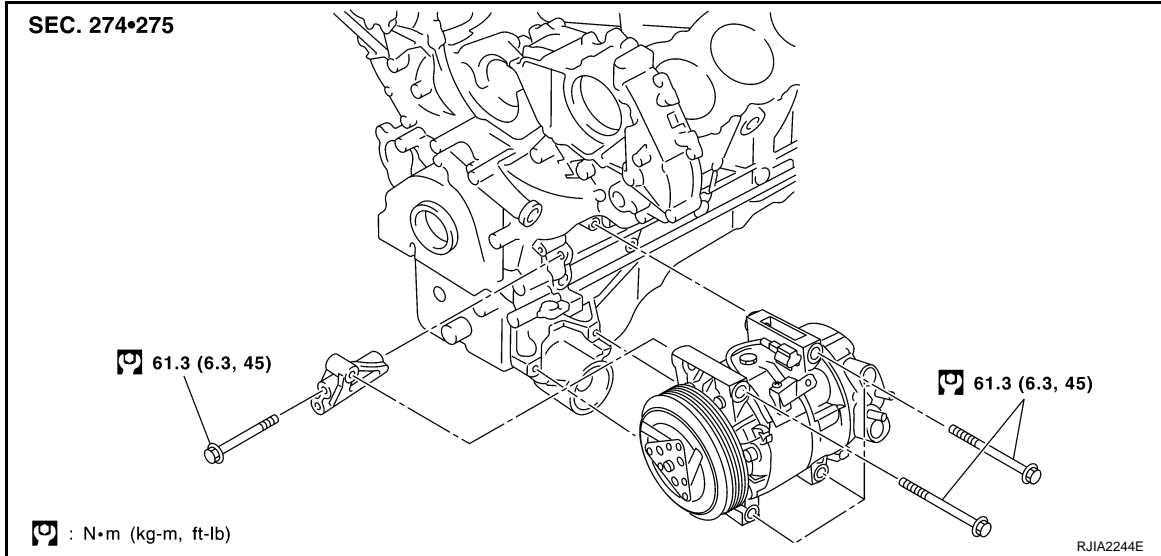

1. Use a refrigerant collecting equipment (for HFC-134a) to discharge the refrigerant.
2. Remove air cleaner case and air duct. Refer to [EM-17](#) (VQ35DE) or [EM-173](#) (VK45DE).
3. Remove front engine undercover, using power tools.
4. Remove cooling fan shroud (lower). Refer to [CO-40](#) (VK45DE).
5. Remove mounting nuts from low-pressure flexible hose and high-pressure flexible hose.
CAUTION:
Cap or wrap the joint of compressor, low-pressure flexible hose and high-pressure flexible hose with suitable material such as vinyl tape to avoid the entry of air.
6. Remove high-pressure flexible hose. Refer to [ATC-129](#), "[Removal and Installation of High-pressure Flexible Hose](#)" (VK45DE).
7. Disconnect compressor connector.

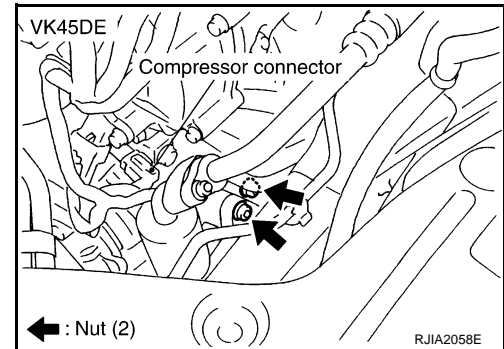
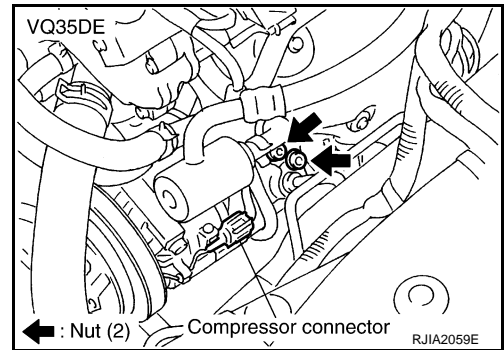

8. Remove A/C compressor belt. Refer to [EM-15](#), "[Removal and Installation](#)" (VQ35DE) or [EM-170](#), "[Removal and Installation](#)" (VK45DE).

REFRIGERANT LINES

< SERVICE INFORMATION >

9. Disconnect compressor (ECV) connector.
10. Remove mounting bolts from compressor, using power tools.
11. Remove compressor downward of the vehicle.

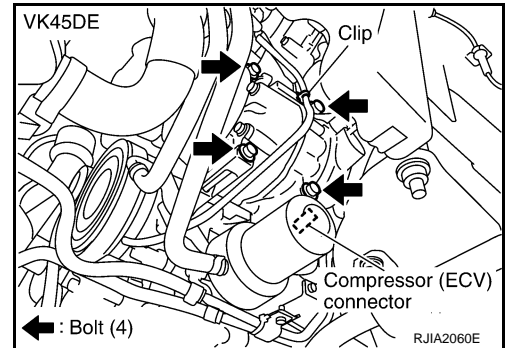
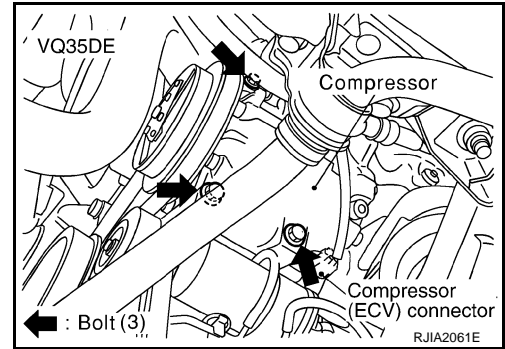

INSTALLATION

Installation is basically the reverse order of removal.

CAUTION:

- Replace O-rings of low-pressure flexible hose and high-pressure flexible hose with new ones, and then apply compressor oil to it when installing it.
- When recharging refrigerant, check for leaks.

Removal and Installation of Compressor Clutch

INFOID:000000001328220

ATC

REMOVAL

Overhaul

1. When removing center bolt, hold clutch disc with a clutch disc wrench (SST).

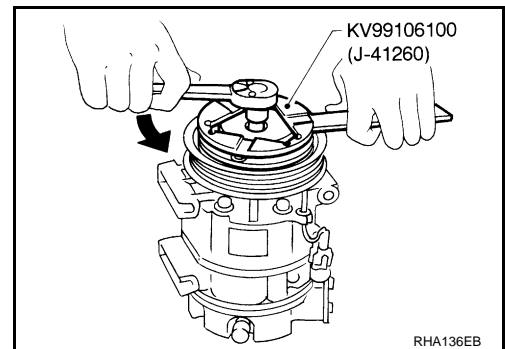

2. Remove clutch disc using a clutch disc puller (SST).

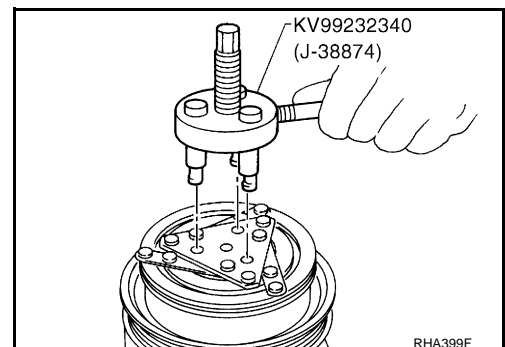

A
B
C
D
E
F
G
H
I
K
L
M
N
O
P

REFRIGERANT LINES

< SERVICE INFORMATION >

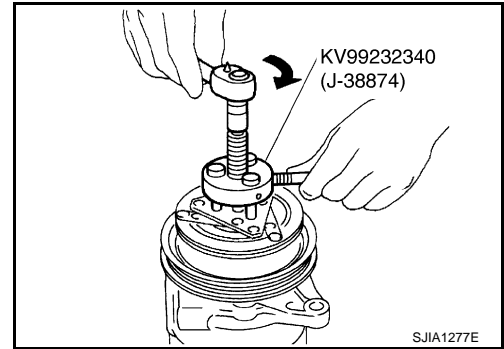

3. Remove snap ring using external snap ring pliers.

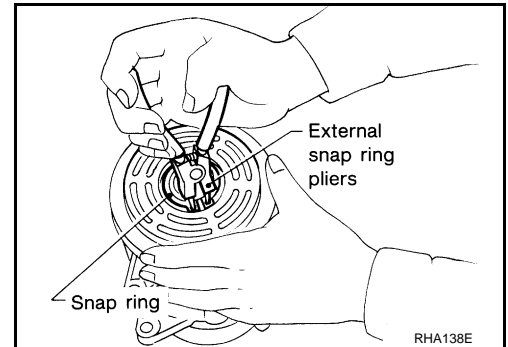

4. Position center pulley puller on the end of drive shaft, and remove pulley assembly using any commercially available pulley puller.
To prevent pulley groove from being deformed, puller claws should be positioned into the edge of pulley assembly.

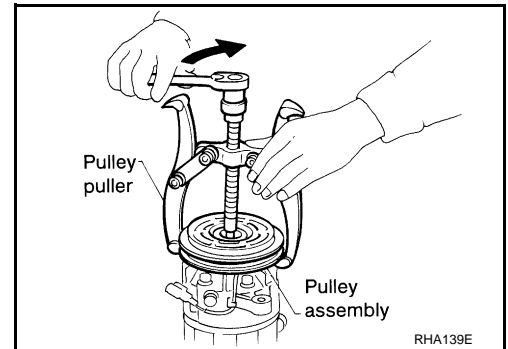

5. Remove field coil harness clip using a pair of pliers.

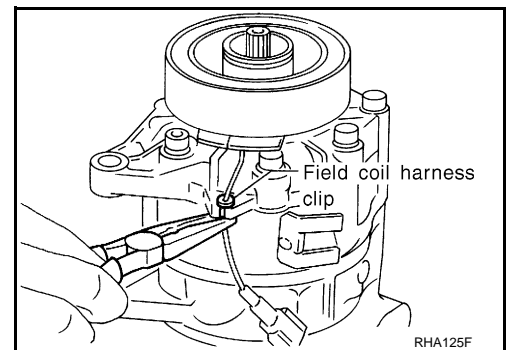

6. Remove snap ring using external snap ring pliers.

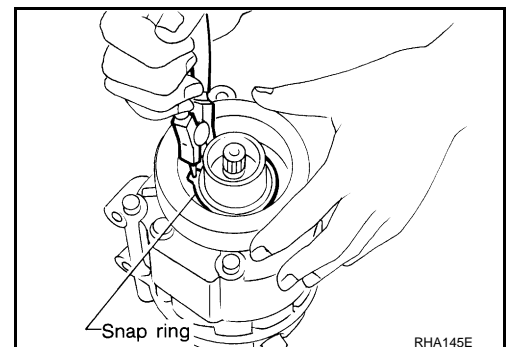

REFRIGERANT LINES

< SERVICE INFORMATION >

Inspection

Clutch disc

If the contact surface shows signs of damage due to excessive heat, replace clutch disc and pulley.

Pulley

Check appearance of pulley assembly. If contact surface of pulley shows signs of excessive grooving, replace clutch disc and pulley. Contact surfaces of pulley assembly should be cleaned with a suitable solvent before reinstallation.

Coil

Check coil for loose connection or cracked insulation.

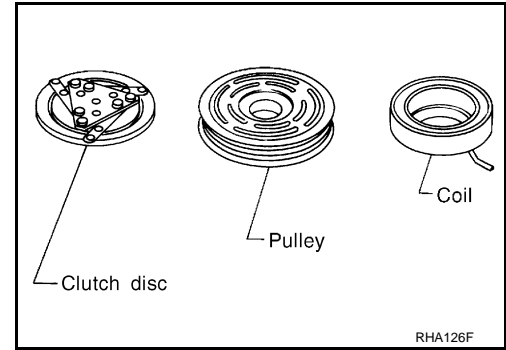

INSTALLATION

1. Install field coil.

Be sure to align coil's pin with hole in compressor's front head.

2. Install field coil harness clip using a screwdriver.

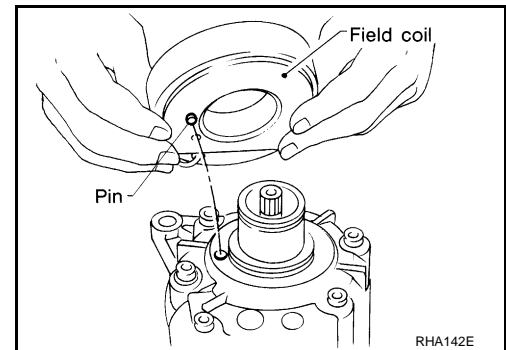

3. Install pulley assembly using pulley installer (SST) and a hand press, and then install snap ring using snap ring pliers.

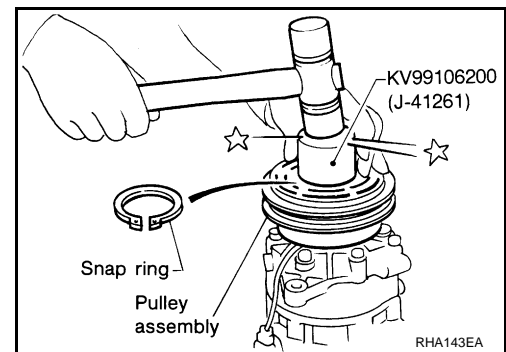

4. Install clutch disc on drive shaft, together with original shim(s). Press clutch disc down by hand.

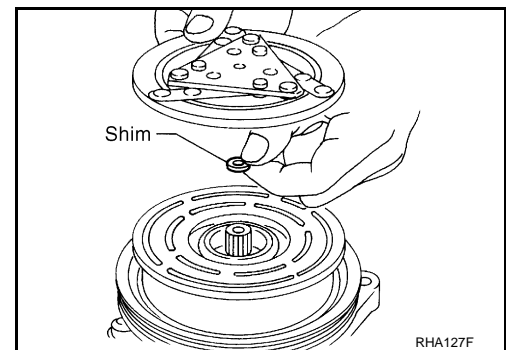

A
B
C
D
E
F
G
H
I
ATC
K
L
M
N
O
P

REFRIGERANT LINES

< SERVICE INFORMATION >

5. Using holder to prevent clutch disc rotation.

 : 14 N·m (1.4 kg-m, 10 ft-lb)

After tightening bolt, make sure pulley rotates smoothly.

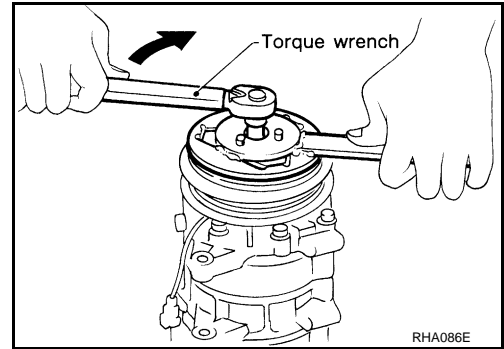

6. Check clearance around entire periphery of clutch disc.

Disc to pulley clearance : 0.25 - 0.6 mm (0.010 - 0.024 in)

If specified clearance is not obtained, replace adjusting spacer and readjust.

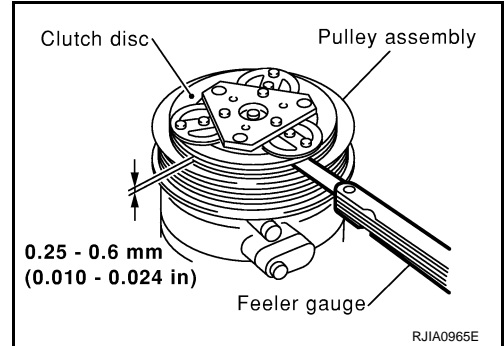

Break-in Operation

When replacing compressor clutch assembly, always carry out break-in operation. This is done by engaging and disengaging clutch about thirty-times. Break-in operation raises the level of transmitted torque.

Removal and Installation of Low-Pressure Flexible Hose

INFOID:000000001328221

REMOVAL

1. Use a refrigerant collecting equipment (for HFC-134a) to discharge the refrigerant.
2. Remove the air cleaner case and air duct. Refer to [EM-17](#) (VQ35DE) or [EM-173](#) (VK45DE).
3. Remove low-pressure flexible hose bracket mounting bolt.

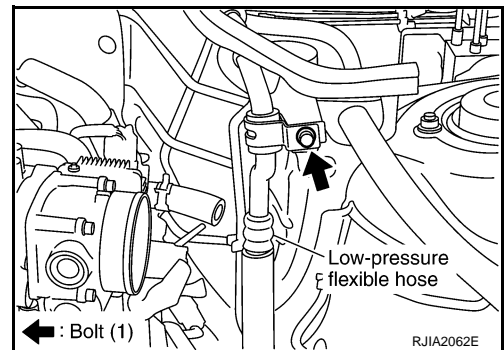

4. Disconnect one-touch joint between low-pressure flexible hose and low-pressure pipe 1.

- a. Set a disconnecter (SST: 9253089916) on A/C piping.
- b. Slide a disconnecter toward vehicle front until it clicks.
- c. Slide A/C piping toward vehicle front and disconnect it.

CAUTION:

Cap or wrap the joint of low-pressure flexible hose and low-pressure pipe 1 with suitable material such as vinyl tape to avoid the entry of air.

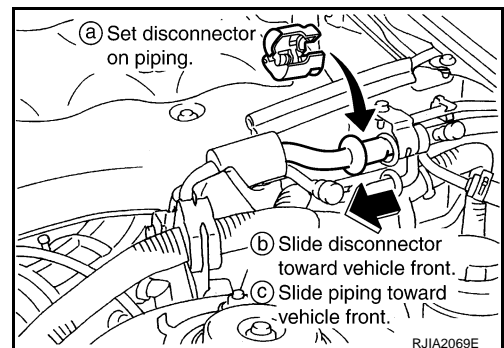

REFRIGERANT LINES

< SERVICE INFORMATION >

5. Remove mounting nut from low-pressure flexible hose.

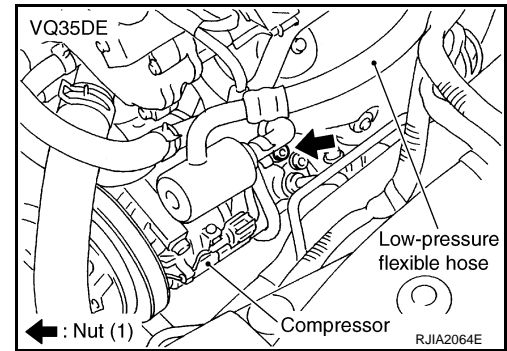

6. Remove mounting nut, and then remove low-pressure pipe (VK45DE).

CAUTION:

Cap or wrap the joint of compressor and low-pressure flexible hose with suitable material such as vinyl tape to avoid the entry of air.

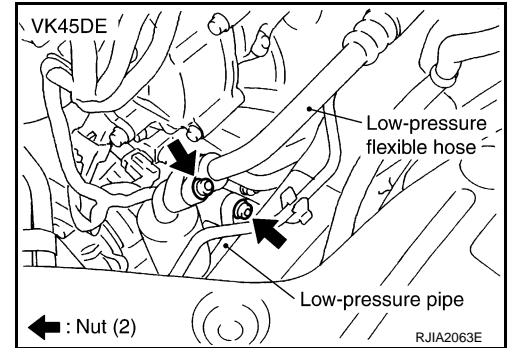

7. Remove low-pressure flexible hose.

CAUTION:

Cap or wrap the joint of compressor and low-pressure pipe 1 with suitable material such as vinyl tape to avoid the entry of air.

INSTALLATION

Installation is basically the reverse order of removal.

CAUTION:

- Replace O-rings of low-pressure flexible hose and low-pressure pipe (VK45DE) with new ones, and then apply compressor oil to it when installing it.
- Female-side piping connection is thin and easy to deform. Slowly insert the male-side piping straight in axial direction.
- Insert piping securely until a click is heard.
- After piping connection is completed, pull male-side piping by hand to make sure that connection does not come loose.
- When recharging refrigerant, check for leaks.

Low-pressure flexible hose bracket mounting bolt

 : 5.5 N·m (0.56 kg·m, 49 in·lb)

Removal and Installation of High-pressure Flexible Hose

INFOID:000000001328222

REMOVAL

1. Use a refrigerant collecting equipment (for HFC-134a) to discharge the refrigerant.
2. Remove air cleaner case and air duct. Refer to [EM-17](#) (VQ35DE) or [EM-173](#) (VK45DE).

A
B
C
D
E
F
G
H
I
K
L
M
N
O
P

ATC

REFRIGERANT LINES

< SERVICE INFORMATION >

3. Remove high-pressure flexible hose bracket mounting bolt.

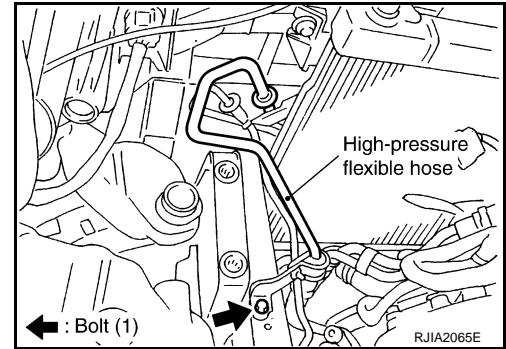

4. Disconnect one-touch joint between high-pressure flexible hose and condenser.
 - a. Set a disconnecter (SST: 9253089912) on A/C piping.
 - b. Slide a disconnecter upward until it clicks.
 - c. Slide A/C piping upward and disconnect it.

CAUTION:

Cap or wrap the joint of condenser and high-pressure flexible hose with suitable material such as vinyl tape to avoid the entry of air.

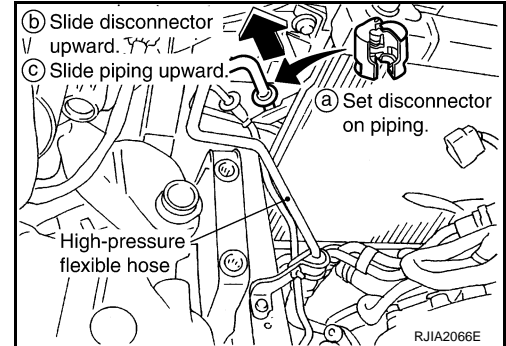

5. Remove mounting nut from high-pressure flexible hose (compressor side), and then remove high-pressure flexible hose.

CAUTION:

Cap or wrap the joint of compressor and high-pressure flexible hose with suitable material such as vinyl tape to avoid the entry of air.

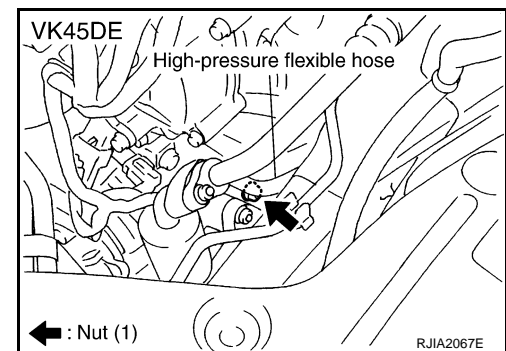
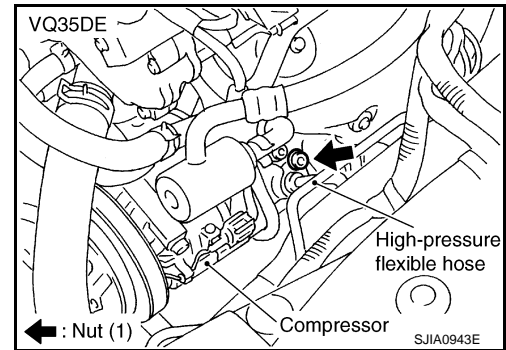

INSTALLATION

Installation is basically the reverse order of removal.

CAUTION:

- Replace O-rings of high-pressure flexible hose with new ones, and then apply compressor oil to it when installing it.
- Female-side piping connection is thin and easy to deform. Slowly insert the male-side piping straight in axial direction.
- Insert piping securely until a click is heard.
- After piping connection is completed, pull male-side piping by hand to make sure that connection does not come loose.
- When recharging refrigerant, check for leaks.

REFRIGERANT LINES

< SERVICE INFORMATION >

High-pressure flexible hose bracket mounting bolt

 : 5.5 N·m (0.56 kg·m, 49 in·lb)

Removal and Installation of Low-Pressure Pipe 1 (Engine Compartment)

INFOID:000000001328223

REMOVAL

1. Use a refrigerant collecting equipment (for HFC-134a) to discharge the refrigerant.
2. Remove cowl top cover. Refer to [EI-23](#).
3. Remove low-pressure pipe 1 bracket and low-pressure flexible hose bracket mounting bolts.

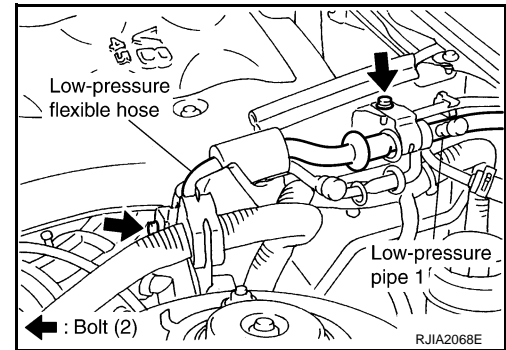

4. Disconnect one-touch joints.
 - a. Set a disconnecter (SST: 9253089916) on A/C piping.
 - b. Slide a disconnecter toward vehicle front until it clicks.
 - c. Slide A/C piping toward vehicle front and disconnect it.

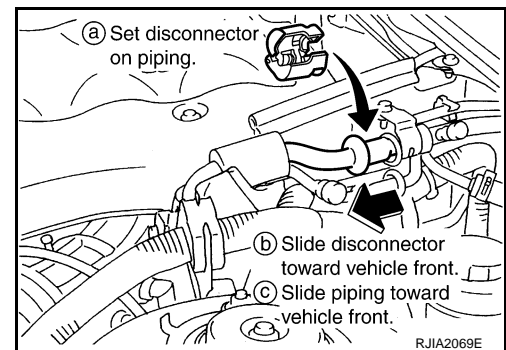

5. Remove low-pressure pipe 1.
CAUTION:
Cap or wrap the joint of low-pressure pipe 1 and 2 with suitable material such as vinyl tape to avoid the entry of air.

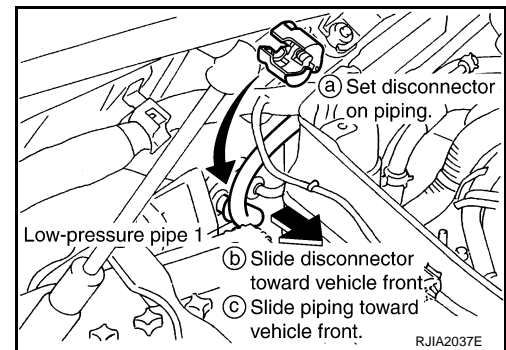

INSTALLATION

Installation is basically the reverse order of removal.

CAUTION:

- Replace O-rings of low-pressure pipe 1 with new ones, and then apply compressor oil to it when installing it.
- Female-side piping connection is thin and easy to deform. Slowly insert the male-side piping straight in axial direction.
- Insert piping securely until a click is heard.
- After piping connection is completed, pull male-side piping by hand to make sure that connection does not come loose.
- When recharging refrigerant, check for leaks.

REFRIGERANT LINES

< SERVICE INFORMATION >

Low-pressure pipe 1 bracket and low-pressure flexible hose bracket mounting bolts

 : 5.5 N·m (0.56 kg-m, 49 in-lb)

Removal and Installation of High-pressure Pipe 1 and 2 (Engine Compartment)

INFOID:000000001328224

REMOVAL

1. Remove low-pressure pipe 1. Refer to [ATC-131, "Removal and Installation of Low-Pressure Pipe 1 \(Engine Compartment\)"](#).
2. Remove high-pressure flexible hose and low-pressure flexible hose. Refer to [ATC-129, "Removal and Installation of High-pressure Flexible Hose"](#) and [ATC-128, "Removal and Installation of Low-Pressure Flexible Hose"](#).
3. Remove high-pressure pipe 1 and 2 from clips.

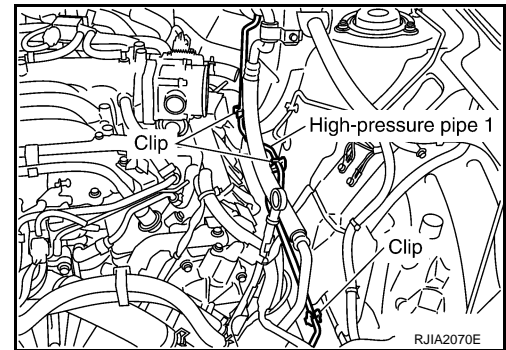

4. Disconnect one-touch joint between condenser and high-pressure pipe 1.
 - a. Set a disconnecter (SST: 9253089908) on A/C piping.
 - b. Slide a disconnecter upward until it clicks.
 - c. Slide A/C piping upward and disconnect it.

CAUTION:

Cap or wrap the joint of condenser and high-pressure pipe 1 with suitable material such as vinyl tape to avoid the entry of air.

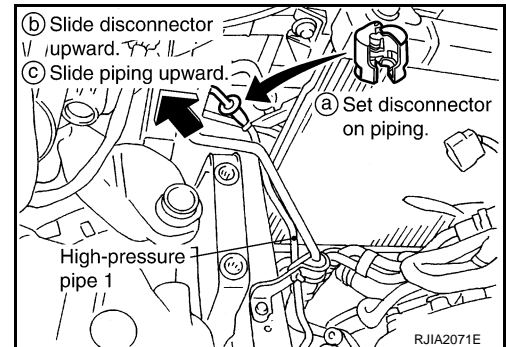

5. Disconnect one-touch joint between high-pressure pipe 1 and 2.
 - a. Set a disconnecter (SST: 9253089908) on A/C piping.
 - b. Slide a disconnecter toward vehicle rear until it clicks.
 - c. Slide A/C piping toward vehicle rear and disconnect it.

CAUTION:

Cap or wrap the joint of high-pressure pipe 1 and 2 with suitable material such as vinyl tape to avoid the entry of air.

6. Remove high-pressure pipe 1.

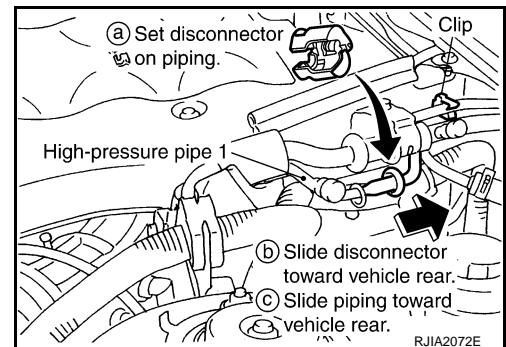

REFRIGERANT LINES

< SERVICE INFORMATION >

7. Disconnect one-touch joint between high-pressure pipe 2 and 3.
 - a. Set a disconnecter (SST: 9253089908) on A/C piping.
 - b. Slide a disconnecter toward vehicle front until it clicks.
 - c. Slide A/C piping toward vehicle front and disconnect it.
8. Remove high-pressure pipe 2.

CAUTION:

Cap or wrap the joint of high-pressure pipe 2 and 3 with suitable material such as vinyl tape to avoid the entry of air.

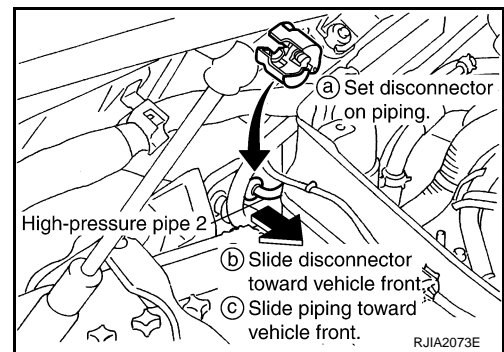

INSTALLATION

Installation is basically the reverse order of removal.

CAUTION:

- Replace O-rings of high-pressure pipe 1 and 2 with new ones, and then apply compressor oil to it when installing it.
- Female-side piping connection is thin and easy to deform. Slowly insert the male-side piping straight in axial direction.
- Insert piping securely until a click is heard.
- After piping connection is completed, pull male-side piping by hand to make sure that connection does not come loose.
- When recharging refrigerant, check for leaks.

Removal and Installation of Low-Pressure Pipe 2 and High-pressure Pipe 3

INFOID:000000001328225

REMOVAL

1. Set the temperature (passenger side) at 18°C (60°F), and then disconnect the battery cable from the negative terminal.
2. Use a refrigerant collecting equipment (for HFC-134a) to discharge the refrigerant.
3. Remove cowl top cover. Refer to [EI-23](#).
4. Remove low-pressure pipe 1 bracket and low-pressure flexible hose bracket mounting bolts.

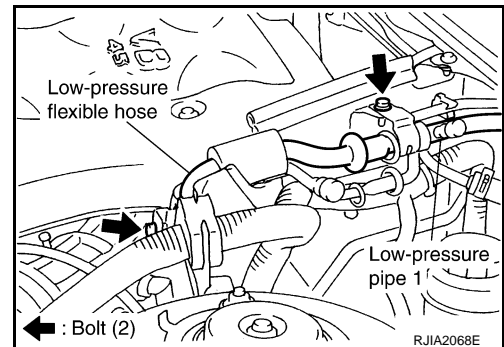

5. Remove high-pressure pipe 1 from vehicle clips.

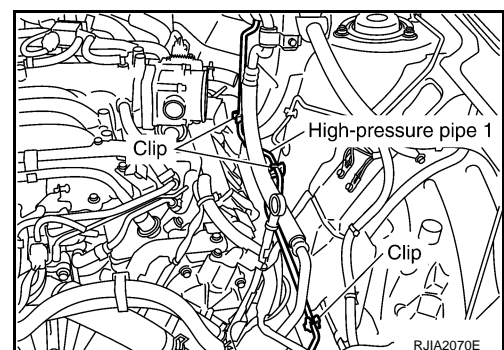

A
B
C
D
E
F
G
H
I
K
L
M
N
O
P

ATC

REFRIGERANT LINES

< SERVICE INFORMATION >

6. Disconnect one-touch joints.
 - a. Set a disconnecter [high-pressure side (SST: 9253089908), low-pressure side (SST: 9253089916)] on A/C piping.
 - b. Slide a disconnecter toward vehicle front until it clicks.
 - c. Slide A/C piping toward vehicle front and disconnect it.

CAUTION:
Cap or wrap the joint of low-pressure pipe 1 and high-pressure pipe 2 with suitable material such as vinyl tape to avoid the entry of air.
7. Remove blower unit. Refer to [ATC-103](#).
8. Remove mounting screws, and then remove air mix door motor (passenger side), mode door motor and evaporator cover.

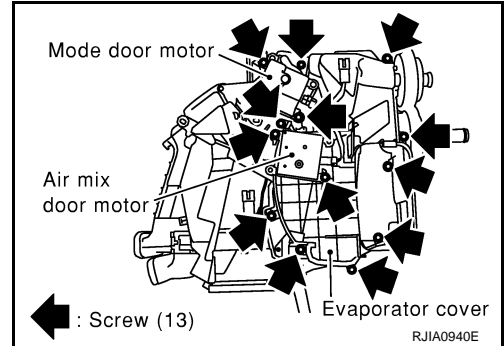
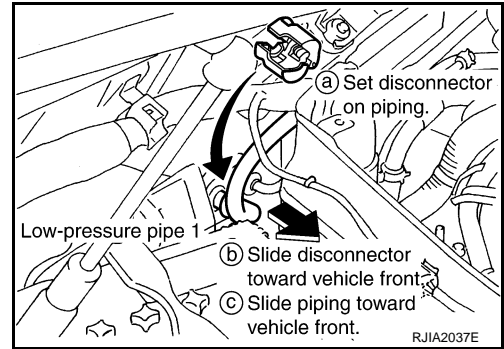

9. Remove mounting bolt, and then remove low-pressure pipe 2 and high-pressure pipe 3.

CAUTION:
Cap or wrap the joint of expansion valve with suitable material such as vinyl tape to avoid the entry of air.

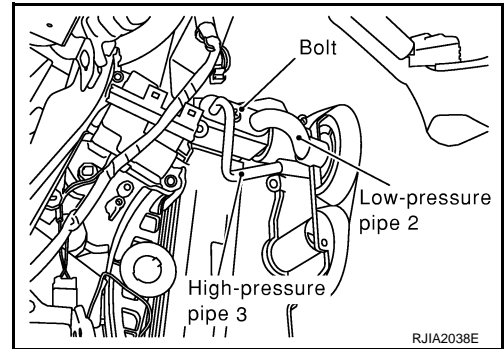

INSTALLATION

Installation is basically the reverse order of removal.

CAUTION:

- Replace O-rings of low-pressure pipe 1, 2 and high-pressure pipe 2, 3 with new ones, and then apply compressor oil to it when installing it.
- Female-side piping connection is thin and easy to deform. Slowly insert the male-side piping straight in axial direction.
- Insert piping securely until a click is heard.
- After piping connection is completed, pull male-side piping by hand to make sure that connection does not come loose.
- When recharging refrigerant, check for leaks.

Low-pressure pipe 1 bracket and low-pressure flexible hose bracket mounting bolts

 : 5.5 N·m (0.56 kg·m, 49 in·lb)

Removal and Installation of Liquid Tank

INFOID:000000001328226

REMOVAL

1. Use a refrigerant collecting equipment (for HFC-134a) to discharge the refrigerant.
2. Remove front grille. Refer to [EI-22](#).
3. Clean liquid tank and its surrounding area, and remove dust and rust from liquid tank.

CAUTION:

REFRIGERANT LINES

< SERVICE INFORMATION >

Be sure to clean carefully.

4. Remove liquid tank and power steering oil cooler mounting bolts.

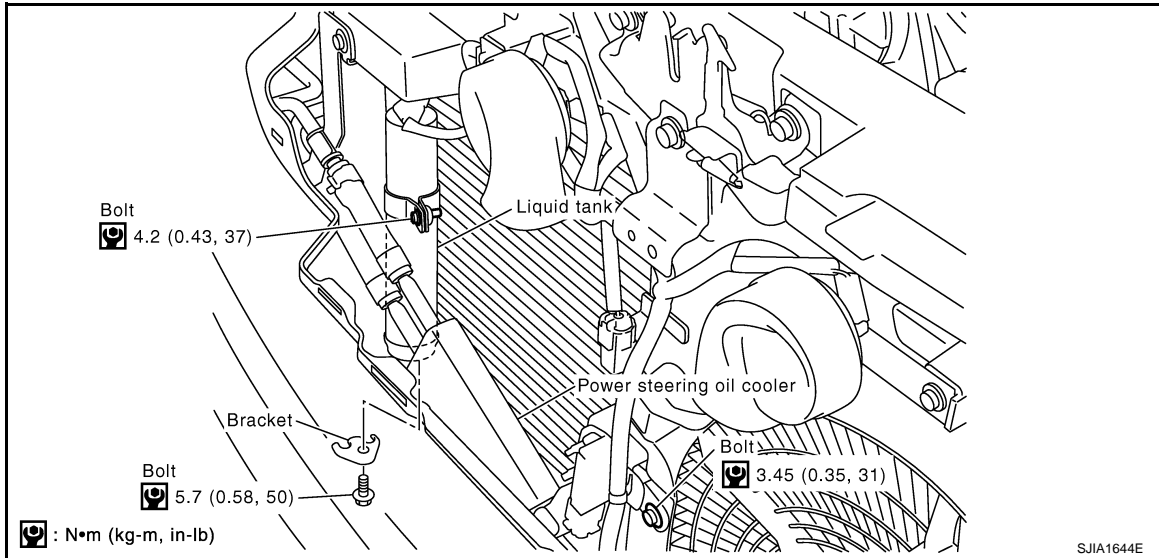

5. Lift liquid tank bracket upward. Remove liquid tank bracket from protruding part of condenser.
6. Slide liquid tank upward, and then remove liquid tank.

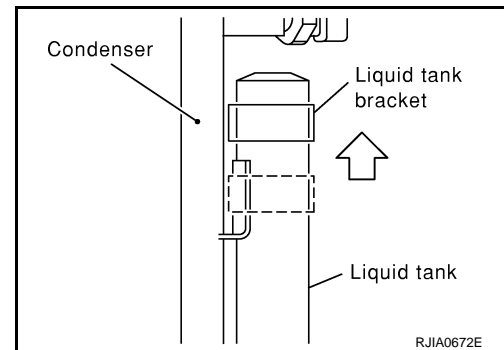

INSTALLATION

Install liquid tank, and then install liquid tank bracket on condenser.

CAUTION:

- Make sure liquid tank bracket is securely installed at protrusion of condenser. (Make sure liquid tank bracket does not move to a position below center of liquid tank.)
- Replace O-rings of condenser pipe with new ones, and then apply compressor oil to it when installing it.
- When recharging refrigerant, check for leaks.

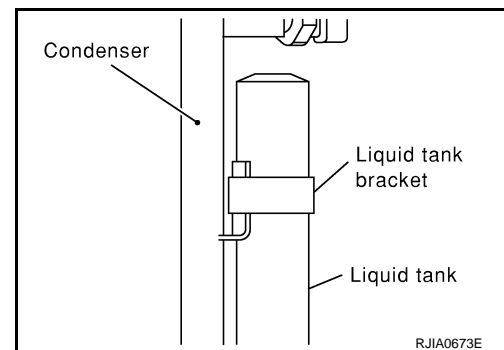

Removal and Installation of Condenser

INFOID:000000001328227

REMOVAL

1. Use a refrigerant collecting equipment (for HFC-134a) to discharge the refrigerant.
2. Remove cooling fan. Refer to [CO-48](#) (VK45DE).
3. Remove radiator cooling fan assembly. Refer to [CO-13](#) (VQ35DE).
4. Remove radiator shroud. Refer to [CO-40](#) (VK45DE).

A
B
C
D
E
F
G
H
I
ATC
K
L
M
N
O
P

REFRIGERANT LINES

< SERVICE INFORMATION >

5. Remove washer tank mounting bolt.

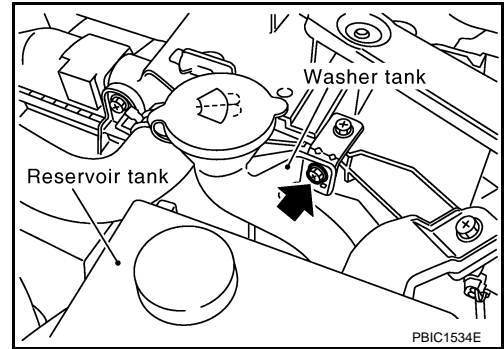

6. Remove high-pressure flexible hose bracket mounting bolt.

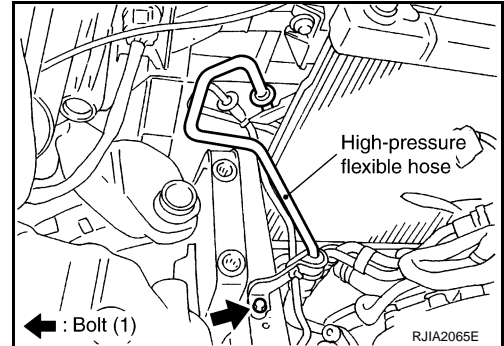

7. Disconnect high-pressure flexible hose and high-pressure pipe 1 from condenser.

- Set a disconnecter [condenser outlet (SST: 9253089908), condenser inlet (SST: 9253089912)] on A/C piping.
- Slide a disconnecter upward until it clicks.
- Slide A/C piping upward and disconnect it.

CAUTION:

Cap or wrap the joint of condenser, high-pressure flexible hose and high-pressure pipe 1 with suitable material such as vinyl tape to avoid the entry of air.

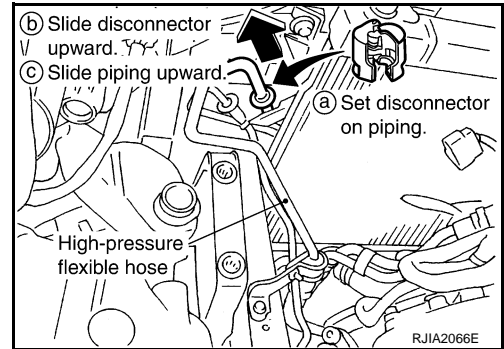

8. Remove condenser mounting bolts.

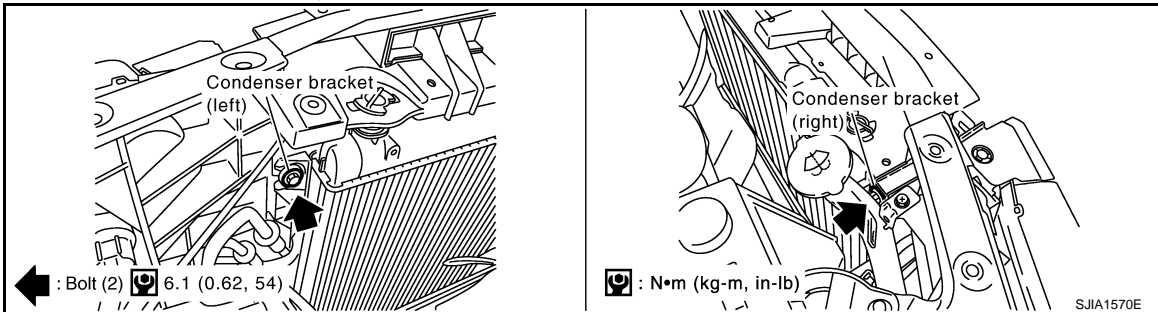

9. Remove radiator upper mount, move radiator and condenser to the engine side.

10. Remove condenser.

CAUTION:

Be careful not to damage the core surface of the condenser and the radiator.

INSTALLATION

Installation is basically the reverse order of removal.

CAUTION:

- Replace O-rings of high-pressure flexible hose and high-pressure pipe 1 with new ones, and then apply compressor oil to it when installing it.
- Female-side piping connection is thin and easy to deform. Slowly insert the male-side piping straight in axial direction.
- Insert piping securely until a click is heard.

REFRIGERANT LINES

< SERVICE INFORMATION >

- After piping connection is completed, pull male-side piping by hand to make sure that connection does not come loose.
- When recharging refrigerant, check for leaks.

High-pressure flexible hose bracket mounting bolt

 : 5.5 N·m (0.56 kg·m, 49 in·lb)

Removal and Installation of Refrigerant Pressure Sensor

INFOID:000000001328228

REMOVAL

1. Remove condenser. Refer to [ATC-135, "Removal and Installation of Condenser"](#).
2. Remove refrigerant pressure sensor from condenser.

CAUTION:

When working, be careful not to damage the condenser.

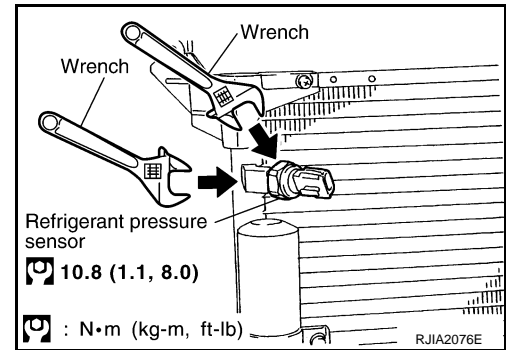

INSTALLATION

Installation is basically the reverse order of removal.

CAUTION:

Apply compressor oil to O-ring of refrigerant pressure sensor when installing it.

Removal and Installation of Evaporator

INFOID:000000001328229

REMOVAL

1. Remove low-pressure pipe 2 and high-pressure pipe 3. Refer to [ATC-133, "Removal and Installation of Low-Pressure Pipe 2 and High-pressure Pipe 3"](#).

CAUTION:

Cap or wrap the joint of evaporator, low-pressure pipe 2 and high-pressure pipe 3 with suitable material such as vinyl tape to avoid the entry of air.

2. Slide evaporator, and then remove it from heater & cooling unit assembly.
3. Remove intake sensor from evaporator, and then remove evaporator.

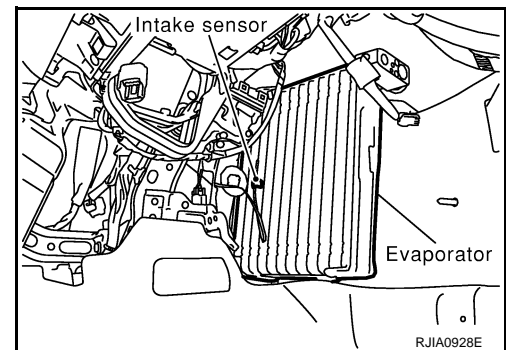

INSTALLATION

Installation is basically the reverse order of removal.

CAUTION:

- Replace O-rings of low-pressure pipe 2 and high-pressure pipe 3 with new ones, and then apply compressor oil to it when installing it.
- Female-side piping connection is thin and easy to deform. Slowly insert the male-side piping straight in axial direction.
- Insert piping securely until a click is heard.
- After piping connection is completed, pull male-side piping by hand to make sure that connection does not come loose.

A
B
C
D
E
F
G
H
I
ATC
K
L
M
N
O
P

REFRIGERANT LINES

< SERVICE INFORMATION >

- O-rings are different from low-pressure pipe 1 (high-pressure pipe 2) and low-pressure pipe 2 (high-pressure pipe 3).
- Mark the mounting position of intake sensor bracket prior to removal so that the reinstalled sensor can be located in the same position.
- When recharging refrigerant, check for leaks.

Low-pressure pipe 1 bracket mounting bolt

 : 5.5 N·m (0.56 kg·m, 49 in·lb)

Removal and Installation of Expansion Valve

INFOID:000000001328230

REMOVAL

1. Remove evaporator. Refer to [ATC-137, "Removal and Installation of Evaporator"](#).
2. Remove mounting bolts, and then remove expansion valve.

CAUTION:

Cap or wrap the joint of evaporator with suitable material such as vinyl tape to avoid the entry of air.

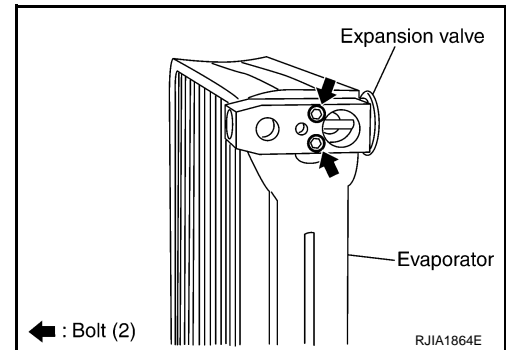

INSTALLATION

Installation is basically the reverse order of removal.

CAUTION:

- Replace O-rings of evaporator with new ones, and then apply compressor oil to it when installing it.
- O-rings are different from low-pressure pipe 1 (high-pressure pipe 2) and low-pressure pipe 2 (high-pressure pipe 3).
- When recharging refrigerant, check for leaks.

Checking of Refrigerant Leaks

INFOID:000000001328231

Perform a visual inspection of all refrigeration parts, fittings, hoses and components for signs of A/C lubricant leakage, damage and corrosion. A/C lubricant leakage may indicate an area of refrigerant leakage. Allow extra inspection time in these areas when using either an electrical leak detector or fluorescent dye leak detector (SST: J-42220).

If dye is observed, confirm the leak with an electrical leak detector. It is possible a prior leak was repaired and not properly cleaned.

When searching for leaks, do not stop when one leak is found but continue to check for additional leaks at all system components and connections.

When searching for refrigerant leaks using an electrical leak detector, move the probe along the suspected leak area at 1 to 2 inches per second and no further than 1/4 inch from the component.

CAUTION:

Moving the electrical leak detector probe slower and closer to the suspected leak area will improve the chances of finding a leak.

Checking System for Leaks Using the Fluorescent Leak Detector

INFOID:000000001328232

1. Check A/C system for leaks using the UV lamp and safety goggles (SST: J-42220) in a low sunlight area (area without windows preferable). Illuminate all components, fittings and lines. The dye will appear as a bright green/yellow area at the point of leakage. Fluorescent dye observed at the evaporator drain opening indicates an evaporator core assembly (tubes, core or expansion valve) leak.
2. If the suspected area is difficult to see, use an adjustable mirror or wipe the area with a clean shop rag or cloth, with the UV lamp for dye residue.
3. After the leak is repaired, remove any residual dye using dye cleaner (SST: J-43872) to prevent future misdiagnosis.

REFRIGERANT LINES

< SERVICE INFORMATION >

4. Perform a system performance check and verify the leak repair with an approved electrical leak detector.

NOTE:

Other gases in the work area or substances on the A/C components, for example, anti-freeze, windshield washer fluid, solvents and lubricants, may falsely trigger the leak detector. Make sure the surfaces to be checked are clean.

Clean with a dry cloth or blow off with shop air.

Do not allow the sensor tip of the detector to contact with any substance. This can also cause false readings and may damage the detector.

Dye Injection

INFOID:000000001328233

(This procedure is only necessary when recharging the system or when the compressor has seized and was replaced.)

1. Check A/C system static (at rest) pressure. Pressure must be at least 345 kPa (3.52 kg/cm², 50 psi).
2. Pour one bottle (1/4 ounce / 7.4 cc) of the A/C refrigerant dye into the injector tool (SST: J-41459).
3. Connect the injector tool to the A/C low-pressure side service valve.
4. Start the engine and switch A/C ON.
5. When the A/C operating (compressor running), inject one bottle (1/4 ounce / 7.4 cc) of fluorescent dye through the low-pressure service valve using dye injector tool (SST: J-41459) (refer to the manufacturer's operating instructions).
6. With the engine still running, disconnect the injector tool from the service valve.

CAUTION:

Be careful the A/C system or replacing a component, pour the dye directly into the open system connection and proceed with the service procedures.

7. Operate the A/C system for a minimum of 20 minutes to mix the dye with the system oil. Depending on the leak size, operating conditions and location of the leak, it may take from minutes to days for the dye to penetrate a leak and become visible.
8. Attach a blue label as necessary.

Electrical Leak Detector

INFOID:000000001328234

PRECAUTIONS FOR HANDLING LEAK DETECTOR

When performing a refrigerant leak check, use an A/C electrical leak detector (SST) or equivalent. Ensure that the instrument is calibrated and set properly per the operating instructions.

The leak detector is a delicate device. In order to use the leak detector properly, read the operating instructions and perform any specified maintenance.

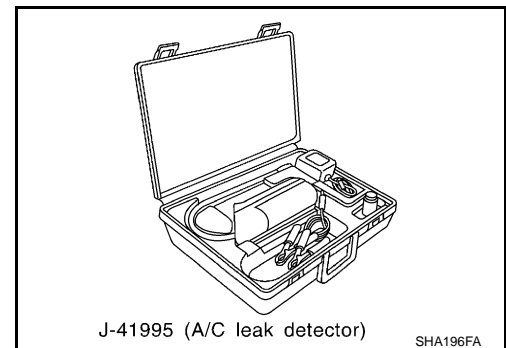

1. Position probe approximately 5 mm (3/16 in) away from point to be checked.

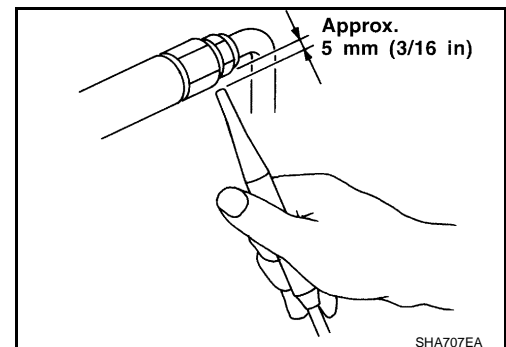

A
B
C
D
E
F
G
H
I
K
L
M
N
O
P

ATC

REFRIGERANT LINES

< SERVICE INFORMATION >

- When testing, circle each fitting completely with probe.

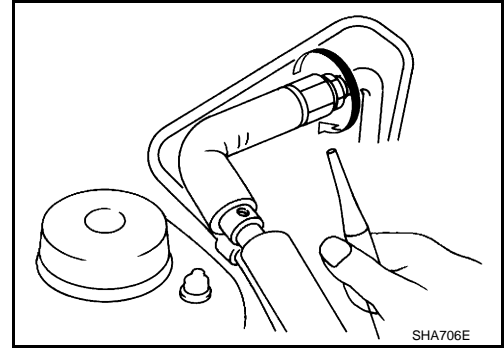

- Move probe along component approximately 25 to 50 mm (1 to 2 in)/sec.

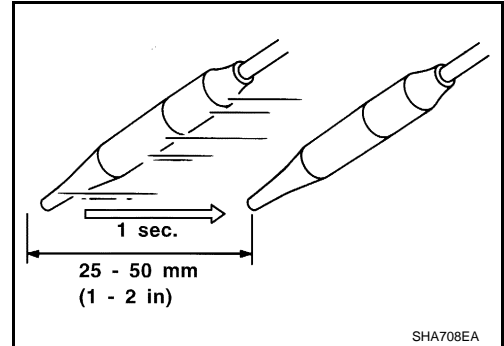

CHECKING PROCEDURE

To prevent inaccurate or false readings, make sure there is no refrigerant vapor, shop chemicals, or cigarette smoke in the vicinity of the vehicle. Perform the leak test in calm area (low air/wind movement) so that the leaking refrigerant is not dispersed.

- Stop the engine.
- Connect a suitable A/C manifold gauge set (SST: J-39183) to the A/C service valves.
- Check if the A/C refrigerant pressure is at least 345 kPa (3.52 kg/cm², 50 psi) above 16°C (61°F). If less than specification, recover/evacuate and recharge the system with the specified amount of refrigerant.

NOTE:

At temperatures below 16°C (61°F), leaks may not be detected since the system may not reach 345 kPa (3.52 kg/cm², 50 psi).

- Perform the leak test from the high-pressure side (compressor discharge a to evaporator inlet h) to the low-pressure side [evaporator drain hose i to shaft seal o (VK45DE) or n (VQ35DE)]. Refer to [ATC-121, "Component"](#). Perform a leak check for the following areas carefully. Clean the component to be checked and move the leak detected probe completely around the connection/component.

Compressor

Check the fitting of high- and low-pressure flexible hoses, relief valve and shaft seal.

Condenser

Check the fitting of high-pressure flexible hose and pipe, refrigerant pressure sensor.

Liquid tank

Check the fitting of refrigerant connection.

Service valves

Check all around the service valves. Ensure service valve caps are secured on the service valves (to prevent leaks).

NOTE:

After removing A/C manifold gauge set from service valves, wipe any residue from valves to prevent any false readings by leak detector.

Cooling unit (Evaporator)

With engine OFF, turn blower fan on "High" for at least 15 seconds to dissipate any refrigerant trace in the cooling unit. Wait a minimum of 10 minutes accumulation time (refer to the manufacturer's recommended procedure for actual wait time) before inserting the leak detector probe into the drain hose.

Keep the probe inserted for at least 10 seconds. Use caution not to contaminate the probe tip with water or dirt that may be in the drain hose.

- If a leak detector detects a leak, verify at least once by blowing compressed air into area of suspected leak, then repeat check as outlined above.

REFRIGERANT LINES

< SERVICE INFORMATION >

6. Do not stop when one leak is found. Continue to check for additional leaks at all system components. If no leaks are found, perform steps 7 - 10.
7. Start the engine.
8. Set the A/C control as follows;
 - a. A/C switch: ON
 - b. Mode door position: VENT (Ventilation)
 - c. Intake position: Recirculation
 - d. Temperature setting: Max. cold
 - e. Fan speed: High
9. Run engine at 1,500 rpm for at least 2 minutes.
10. Stop the engine and perform leak check again following steps 4 through 6 above.

Refrigerant leaks should be checked immediately after stopping the engine. Begin with the leak detector at the compressor. The pressure on the high-pressure side will gradually drop after refrigerant circulation stops and pressure on the low-pressure side will gradually rise, as shown in the graph. Some leaks are more easily detected when pressure is high.

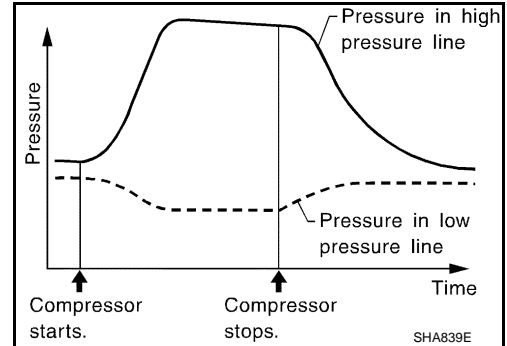

11. Before connecting recovery/recycling recharging equipment to vehicle, check recovery/recycling recharging equipment gauges. No refrigerant pressure should be displayed. If pressure is displayed, recover refrigerant from equipment lines and then check refrigerant purity.
12. Confirm refrigerant purity in supply tank using recovery/recycling recharging equipment and refrigerant identifier.
13. Confirm refrigerant purity in vehicle A/C system using recovery/recycling recharging equipment and refrigerant identifier.
14. Discharge A/C system using approved refrigerant recovery equipment. Repair the leaking fitting or component if necessary.
15. Evacuate and recharge A/C system and perform the leak test to confirm no refrigerant leaks.
16. Perform A/C performance test to ensure system works properly.

SERVICE DATA AND SPECIFICATIONS (SDS)

< SERVICE INFORMATION >

SERVICE DATA AND SPECIFICATIONS (SDS)

Compressor

INFOID:000000001328235

Model		Calsonic Kansei make CWV-618
Type		V-6 variable displacement
Displacement cm ³ (cu in)/rev	Max.	184 (11.228)
	Min.	14.5 (0.885)
Cylinder bore × stroke mm (in)		37 (1.46) × [2.3 - 28.6 (0.091 - 1.126)]
Direction of rotation		Clockwise (viewed from drive end)
Drive belt		Poly V

Lubricant

INFOID:000000001328236

Model		Calsonic Kansei make CWV-618
Name		Nissan A/C System Oil Type S (DH-PS)
Capacity m ℓ (US fl oz, Imp fl oz)	Total in system	180 (6.0, 6.3)
	Compressor (Service part) charging amount	180 (6.0, 6.3)

Refrigerant

INFOID:000000001328237

Type	HFC-134a (R-134a)
Capacity kg (lb)	0.55 (1.21)

Engine Idling Speed

INFOID:000000001328238

Refer to [EC-593, "Idle Speed and Ignition Timing"](#) (VQ35DE) or [EC-1196, "Idle Speed and Ignition Timing"](#) (VK45DE).

Belt Tension

INFOID:000000001328239

Refer to [EM-149, "Standard and Limit"](#) (VQ35DE) or [EM-266, "Standard and Limit"](#) (VK45DE).