

SECTION **RSU**  
 REAR SUSPENSION

A  
B  
C  
D

RSU

CONTENTS

<b>SYMPTOM DIAGNOSIS</b> .....	2	Disposal .....	12	F
<b>NOISE, VIBRATION AND HARSHNESS (NVH) TROUBLESHOOTING</b> .....	2	<b>SUSPENSION ARM</b> .....	13	G
NVH Troubleshooting Chart .....	2	Exploded View .....	13	
<b>PRECAUTION</b> .....	3	Removal and Installation .....	13	
<b>PRECAUTIONS</b> .....	3	Inspection .....	13	H
Precautions for Suspension .....	3	<b>RADIUS ROD</b> .....	15	
<b>PREPARATION</b> .....	4	Exploded View .....	15	I
<b>PREPARATION</b> .....	4	Removal and Installation .....	15	
Special Service Tool .....	4	Inspection .....	15	J
Commercial Service Tool .....	4	<b>FRONT LOWER LINK</b> .....	16	
<b>PERIODIC MAINTENANCE</b> .....	5	Exploded View .....	16	K
<b>REAR SUSPENSION ASSEMBLY</b> .....	5	Removal and Installation .....	16	
Inspection .....	5	Inspection .....	17	L
<b>WHEEL ALIGNMENT</b> .....	6	<b>REAR STABILIZER</b> .....	18	
Inspection .....	6	Exploded View .....	18	M
Adjustment .....	6	Removal and Installation .....	18	
<b>REMOVAL AND INSTALLATION</b> .....	8	Inspection .....	19	N
<b>REAR LOWER LINK &amp; COIL SPRING</b> .....	8	<b>UNIT REMOVAL AND INSTALLATION</b> .....	20	
Exploded View .....	8	<b>REAR SUSPENSION MEMBER</b> .....	20	O
Removal and Installation .....	9	Exploded View .....	20	
Inspection .....	9	Removal and Installation .....	20	P
<b>REAR SHOCK ABSORBER</b> .....	10	Inspection .....	21	
Exploded View .....	10	<b>SERVICE DATA AND SPECIFICATIONS (SDS)</b> .....	23	
Removal and Installation .....	10	<b>SERVICE DATA AND SPECIFICATIONS (SDS)</b> .....	23	
Disassembly and Assembly .....	11	Wheel Alignment .....	23	
Inspection .....	11	Ball Joint .....	23	
		Wheel Height .....	23	

# NOISE, VIBRATION AND HARSHNESS (NVH) TROUBLESHOOTING

< SYMPTOM DIAGNOSIS >

## SYMPTOM DIAGNOSIS

### NOISE, VIBRATION AND HARSHNESS (NVH) TROUBLESHOOTING

#### NVH Troubleshooting Chart

INFOID:000000006565870

Use chart below to find the cause of the symptom. If necessary, repair or replace these parts.

Symptom		Possible cause and SUSPECTED PARTS													Reference			
		Improper installation, looseness	Shock absorber deformation, damage or deflection	Bushing or mounting deterioration	Parts interference	Spring fatigue	Suspension looseness	Incorrect wheel alignment	Stabilizer bar fatigue	PROPELLER SHAFT	DIFFERENTIAL	REAR AXLE AND REAR SUSPENSION	TIRE	ROAD WHEEL		DRIVE SHAFT	BRAKE	STEERING
REAR SUSPENSION	Noise	x	x	x	x	x	x			x	x	x	x	x	x	x	x	RSU-8, RSU-10, RSU-13, RSU-15, RSU-16, RSU-18, RSU-20
	Shake	x	x	x	x		x			x		x	x	x	x			RSU-11
	Vibration	x	x	x	x	x				x		x		x				—
	Shimmy	x	x	x	x			x				x	x	x		x	x	—
	Judder	x	x	x								x	x	x		x	x	—
	Poor quality ride or handling	x	x	x	x	x		x	x			x	x	x				RSU-8, RSU-10, RSU-13, RSU-15, RSU-16, RSU-18, RSU-20
																	RSU-18	
																		NVH in DLN section.
																		NVH in DLN section.
																		NVH in RAX and RSU sections.
																		NVH in WT section.
																		NVH in WT section.
																		NVH in RAX section.
																		NVH in BR section.
																		NVH in ST section.

x: Applicable

# PRECAUTIONS

< PRECAUTION >

## PRECAUTION

### PRECAUTIONS

#### Precautions for Suspension

INFOID:000000006565871

**CAUTION:**

- When installing rubber bushings, the final tightening must be carried out under unladen conditions with tires on ground. Spilled oil might shorten the life of rubber bushings. Be sure to wipe off any spilled oil.
- Unladen conditions mean that fuel, engine coolant and lubricant are full. Spare tire, jack, hand tools and mats are in designated positions.
- After servicing suspension parts, be sure to check wheel alignment.
- Self-lock nuts are not reusable. Always use new ones when installing. Since new self-lock nuts are pre-oiled, tighten as they are.

A

B

C

D

RSU

F

G

H

I

J

K

L

M

N

O

P

# PREPARATION

< PREPARATION >

## PREPARATION

### PREPARATION

#### Special Service Tool

INFOID:000000006565872

The actual shapes of Kent-Moore tools may differ from those of special service tools illustrated here.

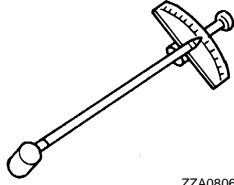
Tool number (Kent-Moore No.) Tool name	Description
ST3127S000 (J-25765-A) Preload gauge  ZZA0806D	Measuring rotating torque of ball joint

#### Commercial Service Tool

INFOID:000000006565873

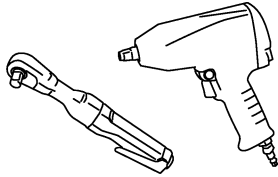
Tool name	Description
Power tool  PBIC0190E	Loosening bolts and nuts

# REAR SUSPENSION ASSEMBLY

< PERIODIC MAINTENANCE >

## PERIODIC MAINTENANCE

### REAR SUSPENSION ASSEMBLY

#### Inspection

INFOID:000000006565874

#### COMPONENT PART

Check the mounting conditions (looseness, backlash) of each component and component conditions (wear, damage) are normal.

#### Ball Joint Axial End Play

Move axle side of suspension arm in the axial direction by hand.  
Check there is no end play.

**Axial end play** : Refer to [RSU-23, "Ball Joint"](#).

#### CAUTION:

- Never depress brake pedal when measuring.
- Never perform with tires on level ground.
- Be careful not to damage ball joint boot. Never damage the installation position by applying excessive force.

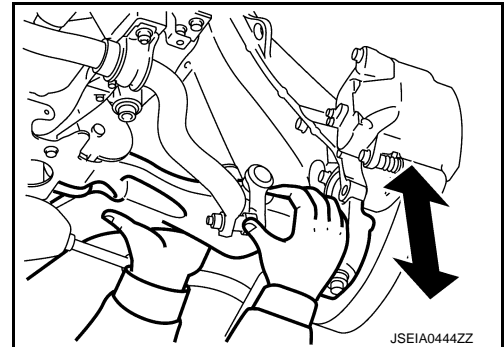

#### SHOCK ABSORBER

Check for oil leakage and damage. Replace it if necessary.

A  
B  
C  
D  
RSU  
F  
G  
H  
I  
J  
K  
L  
M  
N  
O  
P

# WHEEL ALIGNMENT

< PERIODIC MAINTENANCE >

## WHEEL ALIGNMENT

### Inspection

INFOID:000000006565875

#### DESCRIPTION

Measure wheel alignment under unladen conditions.

#### NOTE:

"Unladen conditions" means that fuel, engine coolant, and lubricant are full. Spare tire, jack, hand tools and mats are in designated positions.

#### PRELIMINARY CHECK

Check the following:

- Tires for improper air pressure and wear. Refer to [WT-85, "Tire Air Pressure"](#).
- Road wheels for runout.
- Wheel bearing axial end play. Refer to [RAX-5, "Inspection"](#).
- Ball joint axial end play of suspension arm. Refer to [RSU-5, "Inspection"](#).
- Shock absorber operation.
- Each mounting point of axle and suspension for looseness and deformation.
- Each of front lower link, rear lower link, radius rod, rear suspension member, suspension arm and shock absorber for cracks, deformation, and other damage.
- Vehicle height (posture).

#### GENERAL INFORMATION AND RECOMMENDATIONS

- A four-wheel thrust alignment should be performed.
- This type of alignment is recommended for any NISSAN/INFINITI vehicle.
- The four-wheel "thrust" process helps ensure that the vehicle is properly aligned and the steering wheel is centered.
- The alignment rack itself should be capable of accepting any NISSAN/INFINITI vehicle.
- The rack should be checked to ensure that it is level.
- Make sure the machine is properly calibrated.
- Your alignment equipment should be regularly calibrated in order to give correct information.
- Check with the manufacturer of your specific equipment for their recommended Service/Calibration Schedule.

#### ALIGNMENT PROCESS

#### IMPORTANT:

Use only the alignment specifications listed in this Service Manual.

- When displaying the alignment settings, many alignment machines use "indicators": (Green/red, plus or minus, Go/No Go). **Do not use these indicators.**
- The alignment specifications programmed into your machine that operate these indicators may not be correct.
- This may result in an ERROR.
- Most camera-type alignment machines are equipped with both "Rolling Compensation" method and optional "Jacking Compensation" method to "compensate" the alignment targets or head units. "Rolling Compensation" is the preferred method.
- If using the "Rolling Compensation" method, after installing the alignment targets or head units, push or pull on the rear wheel to move the vehicle. **Do not push or pull on the vehicle body.**
- If using the "Jacking Compensation" method, after installing the alignment targets or head units, raise the vehicle and rotate the wheels 1/2 turn both ways.

#### NOTE:

- Do not use the "Rolling Compensation" method if you are using sensor-type alignment equipment.
- Follow all instructions for the alignment machine you're using for more information.

### Adjustment

INFOID:000000006565876

#### CAMBER

# WHEEL ALIGNMENT

## < PERIODIC MAINTENANCE >

If camber exceeds the standard value, adjust with adjusting bolt (1) in front lower link (2).

**Camber:** Refer to [RSU-23, "Wheel Alignment"](#).

**CAUTION:**

After adjusting camber, be sure to check toe-in.

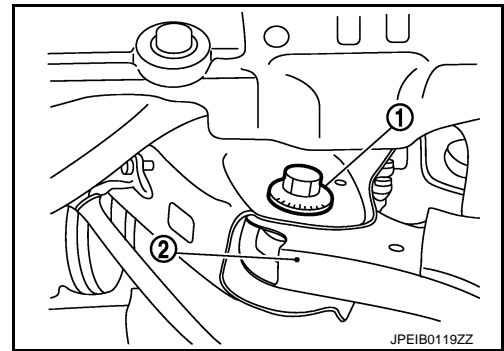

## TOE-IN

Without RAS

• If toe-in exceeds the standard value, adjust with adjusting bolt (1) in rear lower link (2).

**Toe-In:** Refer to [RSU-23, "Wheel Alignment"](#).

**CAUTION:**

Be sure to adjust equally on right and left side with adjusting bolt.

- If toe-in is not still within the specification, inspect and replace any damaged or worn suspension parts.

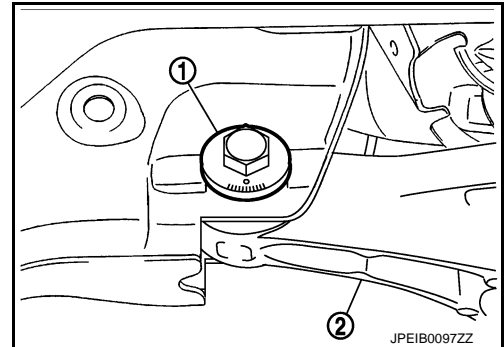

With RAS

• If toe-in exceeds the standard value, adjust with adjusting bolt (1) in rear lower link (2).

**Toe-In:** Refer to [RSU-23, "Wheel Alignment"](#).

**CAUTION:**

Be sure to adjust equally on right and left side with adjusting bolt.

- If toe-in is not still within the specification, inspect and replace any damaged or worn suspension parts.

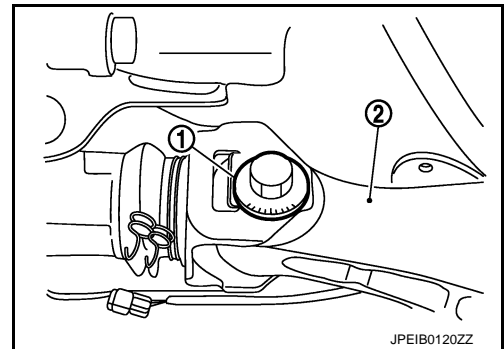

A  
B  
C  
D  
E  
F  
G  
H  
I  
J  
K  
L  
M  
N  
O  
P

RSU

# REAR LOWER LINK & COIL SPRING

< REMOVAL AND INSTALLATION >

## REMOVAL AND INSTALLATION

### REAR LOWER LINK & COIL SPRING

Exploded View

INFOID:000000006565877

WITHOUT RAS

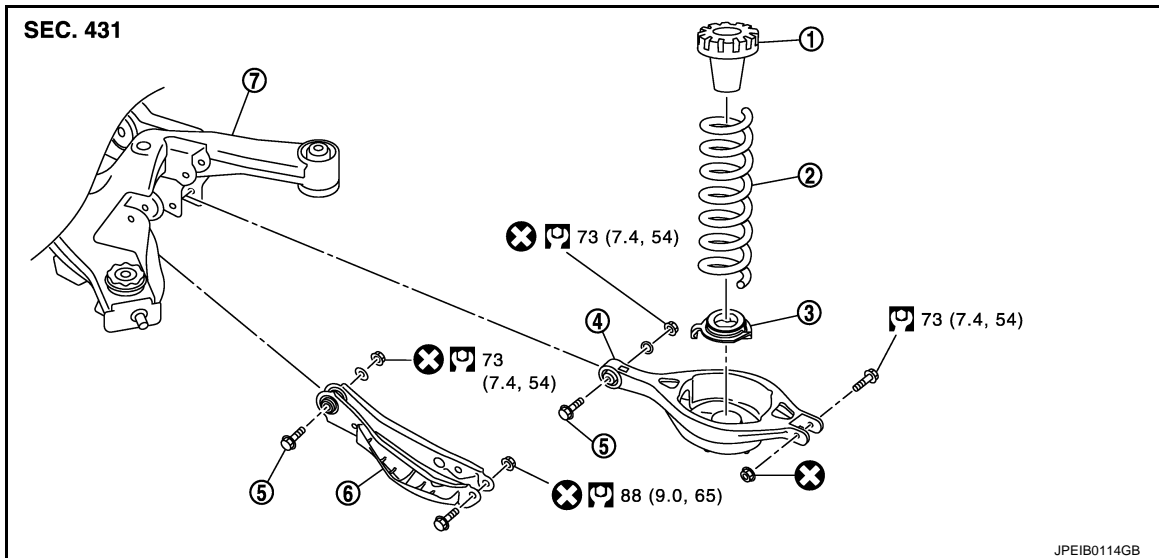

- |                           |                   |                     |
|---------------------------|-------------------|---------------------|
| 1. Upper seat             | 2. Coil spring    | 3. Rubber seat      |
| 4. Rear lower link        | 5. Adjusting bolt | 6. Front lower link |
| 7. Rear suspension member |                   |                     |

Refer to [GI-4, "Components"](#) for symbols in the figure.

WITH RAS

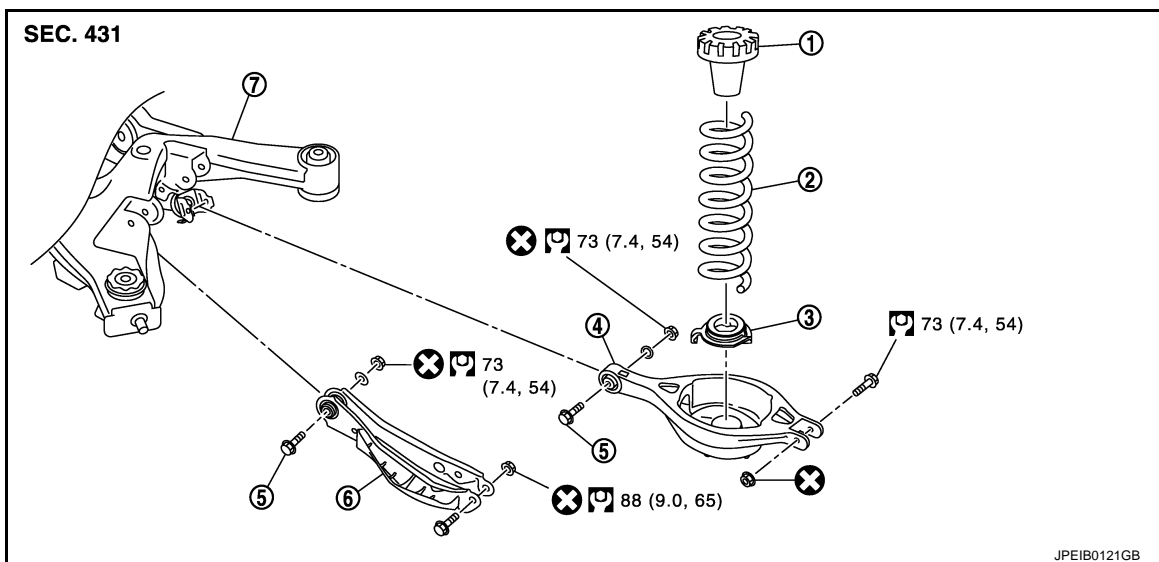

- |                           |                   |                     |
|---------------------------|-------------------|---------------------|
| 1. Upper seat             | 2. Coil spring    | 3. Rubber seat      |
| 4. Rear lower link        | 5. Adjusting bolt | 6. Front lower link |
| 7. Rear suspension member |                   |                     |

Refer to [GI-4, "Components"](#) for symbols in the figure.



# REAR LOWER LINK & COIL SPRING

## < REMOVAL AND INSTALLATION >

### Removal and Installation

INFOID:000000006565878

#### REMOVAL

1. Remove tires with power tool.
2. Set suitable jack under rear lower link to relieve the coil spring tension.
3. Loosen rear lower link mounting nuts [rear suspension member side (without RAS) or RAS actuator assembly (with RAS)], and remove rear lower link mounting bolts and nuts (axle housing side) with power tool.
4. Slowly lower jack, then remove upper seat, coil spring and rubber sheet from rear lower link.
5. Remove rear lower link mounting nuts and adjusting bolts [rear suspension member side (without RAS) or RAS actuator assembly (with RAS)] and remove rear lower link.

#### INSTALLATION

Note the following, and install in the reverse order of removal.

- Match up rubber seat indentions and rear lower link grooves and attach.
- Install coil spring by aligning the lower end of the large diameter side to the step (A) between the rubber seat (1) and the rear lower link (2).

#### **CAUTION:**

**Make sure spring is not up side down.**

- Perform the final tightening of rear suspension member and axle housing rubber bushing position under unladen condition with tires on level ground.

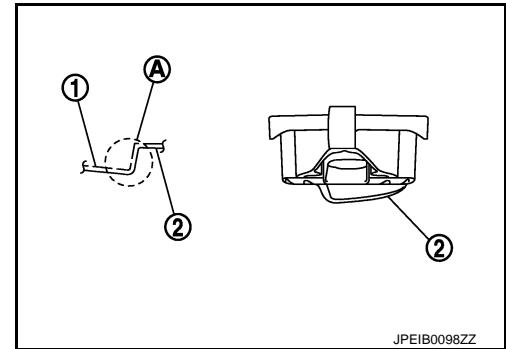

#### Inspection

INFOID:000000006565879

#### INSPECTION AFTER REMOVAL

Check rear lower link, bushing and coil spring for deformation, crack, and damage. Replace it if necessary.

#### INSPECTION AFTER INSTALLATION

1. Check wheel alignment. Refer to [RSU-6. "Inspection"](#).
2. Adjust neutral position of steering angle sensor. Refer to [BRC-10. "ADJUSTMENT OF STEERING ANGLE SENSOR NEUTRAL POSITION : Special Repair Requirement"](#).

# REAR SHOCK ABSORBER

< REMOVAL AND INSTALLATION >

## REAR SHOCK ABSORBER

Exploded View

INFOID:000000006565880

WITHOUT CONTINUOUS DAMPING CONTROL

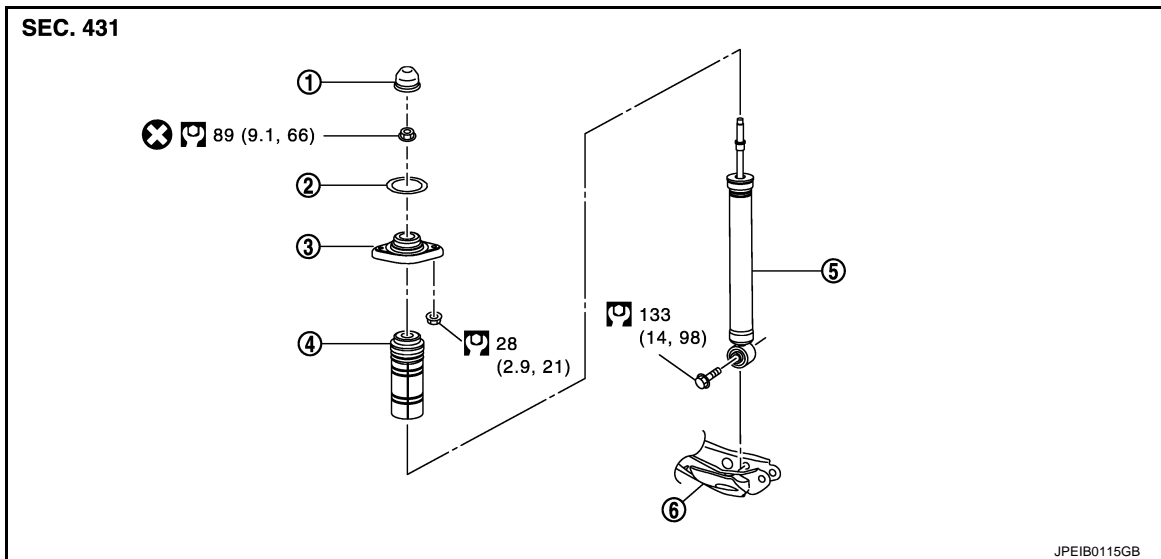

- |                       |                   |                                    |
|-----------------------|-------------------|------------------------------------|
| 1. Cap                | 2. Mounting seal  | 3. Shock absorber mounting bracket |
| 4. Bound bumper cover | 5. Shock absorber | 6. Front lower link                |

Refer to [GI-4, "Components"](#) for symbols in the figure.

WITH CONTINUOUS DAMPING CONTROL

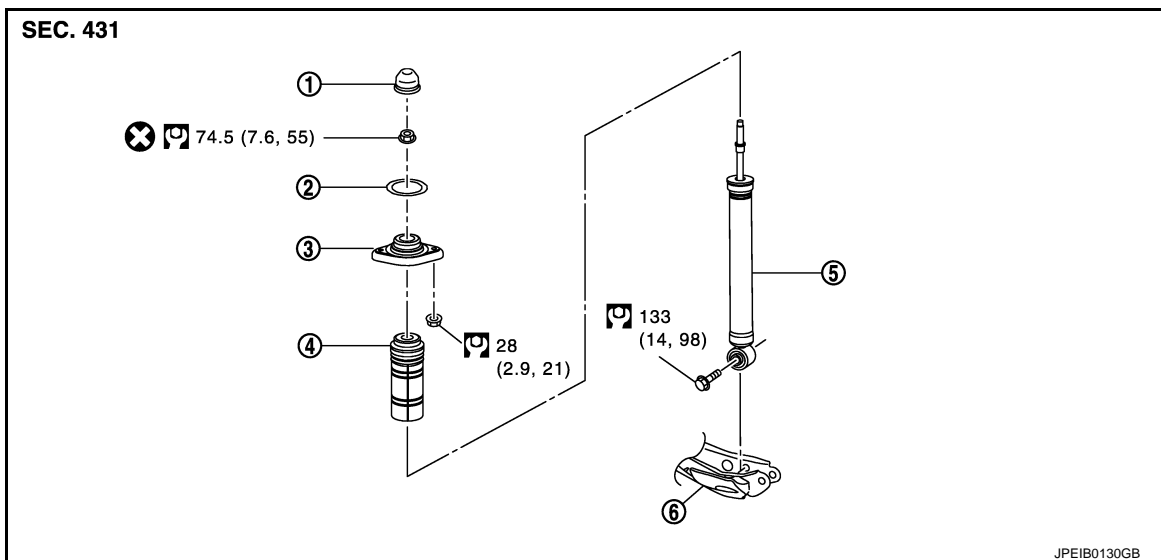

- |                       |                   |                                    |
|-----------------------|-------------------|------------------------------------|
| 1. Cap                | 2. Mounting seal  | 3. Shock absorber mounting bracket |
| 4. Bound bumper cover | 5. Shock absorber | 6. Front lower link                |

Refer to [GI-4, "Components"](#) for symbols in the figure.

## Removal and Installation

INFOID:000000006565881

### REMOVAL

1. Remove tires with power tool.
2. Remove shock absorber actuator harness connector (with Continuous Damping Control).

# REAR SHOCK ABSORBER

## < REMOVAL AND INSTALLATION >

3. Set suitable jack under axle assembly to relieve the coil spring tension.
4. Remove shock absorber (lower side) with power tool.
5. Gradually lower the jack to remove it from rear lower link.
6. Remove shock absorber assembly mounting nuts (upper side) (←), and then remove shock absorber assembly.

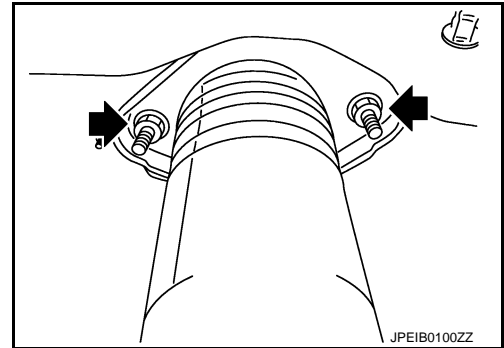

## INSTALLATION

Note the following, and install in the reverse order of removal.

- Perform final tightening of bolts and nuts at the shock absorber lower side (rubber bushing), under unladen conditions with tires on level ground.

## Disassembly and Assembly

INFOID:000000006565882

### DISASSEMBLY

#### **CAUTION:**

**Never damage shock absorber piston rod when removing components from shock absorber.**

1. Remove cap from mounting bracket
2. Wrap a shop cloth around lower side of shock absorber and fix it with a vise.

#### **CAUTION:**

**Never set the cylindrical part of shock absorber with a vise.**

3. Secure the piston rod tip so that piston rod does not turn, and remove piston rod lock nut.
4. Remove mounting seal, mounting bracket and bound bumper cover from shock absorber.

### ASSEMBLY

Install in the reverse order of disassembly.

## Inspection

INFOID:000000006565883

### INSPECTION AFTER REMOVAL

Check the following items, and replace the parts if necessary.

- Shock absorber assembly for deformation, cracks, damage.
- Welded and sealed areas for oil leakage.

### INSPECTION AFTER INSTALLATION

1. Check shock absorber actuator harness connector for proper connection (with Continuous Damping Control).
2. Check wheel alignment. Refer to [RSU-6. "Inspection"](#).
3. Adjust neutral position of steering angle sensor. Refer to [BRC-10. "ADJUSTMENT OF STEERING ANGLE SENSOR NEUTRAL POSITION : Special Repair Requirement"](#).

### INSPECTION AFTER DISASSEMBLY

#### Bound Bumper and Bushing

Check bound bumper cover and bushing for cracks and damage. Replace it if necessary.

#### Shock Absorber

Check the following items, and replace the part if necessary.

- Shock absorber for deformation, cracks, and other damage.
- Piston rod for damage, uneven wear, and distortion.

### INSPECTION AFTER ASSEMBLY

# REAR SHOCK ABSORBER

## < REMOVAL AND INSTALLATION >

Make sure piston rod on shock absorber is not damaged when attaching components to shock absorber.

### Disposal

INFOID:000000006565884

1. Set shock absorber horizontally with the piston rod fully extended.
2. Drill 2 – 3 mm (0.08 – 0.12 in) hole at the position (●) from top as shown in the figure to release gas gradually.

**CAUTION:**

- Wear eye protection (safety glasses).
- Wear gloves.
- Be careful with metal chips or oil blown out by the compressed gas.

**NOTE:**

- Drill vertically in this direction (←).
- Directly to the outer tube avoiding brackets.
- The gas is clear, colorless, odorless, and harmless.

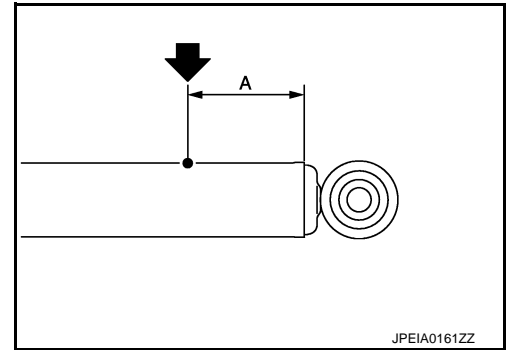

JPEIA0161ZZ

**A : 20 – 30 mm (0.79 – 1.18 in)**

3. Position the drilled hole downward and drain oil by moving the piston rod several times.

**CAUTION:**

**Dispose of drained oil according to the law and local regulations.**

# SUSPENSION ARM

< REMOVAL AND INSTALLATION >

## SUSPENSION ARM

### Exploded View

INFOID:000000006565885

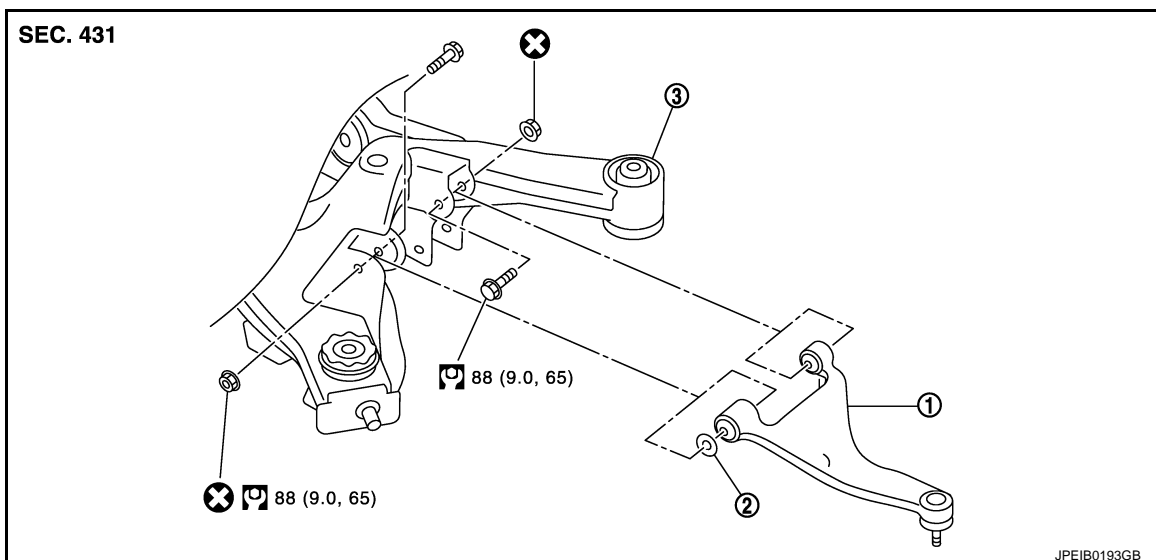

1. Suspension arm
2. Stopper rubber
3. Rear suspension member

Refer to [GI-4, "Components"](#) for symbols in the figure.

## Removal and Installation

INFOID:000000006565886

### REMOVAL

1. Remove tire with power tool.
2. Remove radius rod. Refer to [RSU-15, "Exploded View"](#).
3. Remove caliper assembly mounting bolts. Hang caliper assembly in a place where it will not interfere with work. Refer to [BR-56, "BRAKE CALIPER ASSEMBLY \(1 PISTON TYPE\) : Exploded View"](#) (1 piston type), [BR-60, "BRAKE CALIPER ASSEMBLY \(2 PISTON TYPE\) : Exploded View"](#) (2 piston type).
4. Set suitable jack under axle assembly to relieve the coil spring tension.
5. Remove stabilizer connecting rod. Refer to [RSU-18, "Exploded View"](#).
6. Remove drive shaft. Refer to [RAX-10, "Exploded View"](#).
7. Remove height sensor (with xenon head lamp). Refer to [EXL-313, "Exploded View"](#).
8. Remove cotter pin of suspension arm ball joint, and loosen nut. Refer to [RAX-7, "Exploded View"](#).
9. Remove suspension arm mounting bolts and nuts (rear suspension member side).
10. Use the ball joint remover to remove suspension arm from axle housing. Be careful not to damage ball joint boot.  
**CAUTION:**  
**Tighten temporarily mounting nut to prevent damage to threads and to prevent ball joint remover from coming off.**
11. Remove suspension arm.
12. Remove stabilizer connecting rod mounting bracket. Refer to [RSU-18, "Exploded View"](#).

### INSTALLATION

Note the following and, install in the reverse order of removal.

- Perform final tightening of rear suspension member installation position (rubber bussing), under unladen conditions with tires on level ground.

### Inspection

INFOID:000000006565887

### INSPECTION AFTER REMOVAL

# SUSPENSION ARM

## < REMOVAL AND INSTALLATION >

### Appearance

Check the following items, and replace the part if necessary.

- Suspension arm and bushing for deformation, cracks or damage.
- Boot of ball joint for cracks or damage, and also for grease leakage.

### Ball Joint Inspection

Manually move ball stud at least ten times by hand to check for smooth movement.

### Swing Torque Inspection

- Hook spring balance (A) at cotter pin mounting hole. Confirm spring balance measurement value is within specifications when ball stud begins moving.

**Swing torque** : Refer to [RSU-23, "Ball Joint"](#).

- If swing torque exceeds the standard range, replace suspension arm assembly.

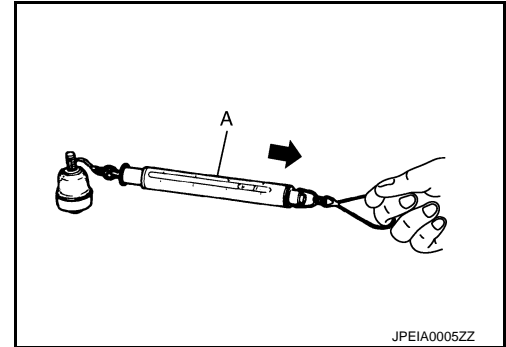

### Rotating Torque Inspection

- Attach the mounting nut to ball stud. Make sure that rotating torque is within the specifications with a preload gauge (A) [SST: ST3127S000 (J-25765-A)].

**Rotating torque** : Refer to [RSU-23, "Ball Joint"](#).

- If rotating torque exceeds the standard range, replace suspension arm assembly.

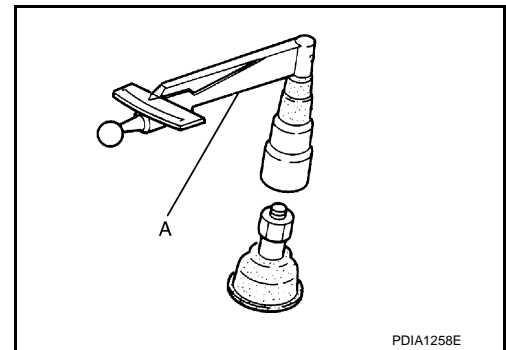

### Axial End Play Inspection

- Move tip of ball stud in axial direction to check for looseness.

**Axial end play** : Refer to [RSU-23, "Ball Joint"](#).

- If axial end play exceeds the standard range, replace suspension arm assembly.

## INSPECTION AFTER INSTALLATION

1. Check wheel alignment. Refer to [RSU-6, "Inspection"](#).
2. Adjust neutral position of steering angle sensor. Refer to [BRC-10, "ADJUSTMENT OF STEERING ANGLE SENSOR NEUTRAL POSITION : Special Repair Requirement"](#).

# RADIUS ROD

< REMOVAL AND INSTALLATION >

## RADIUS ROD

### Exploded View

INFOID:000000006565888

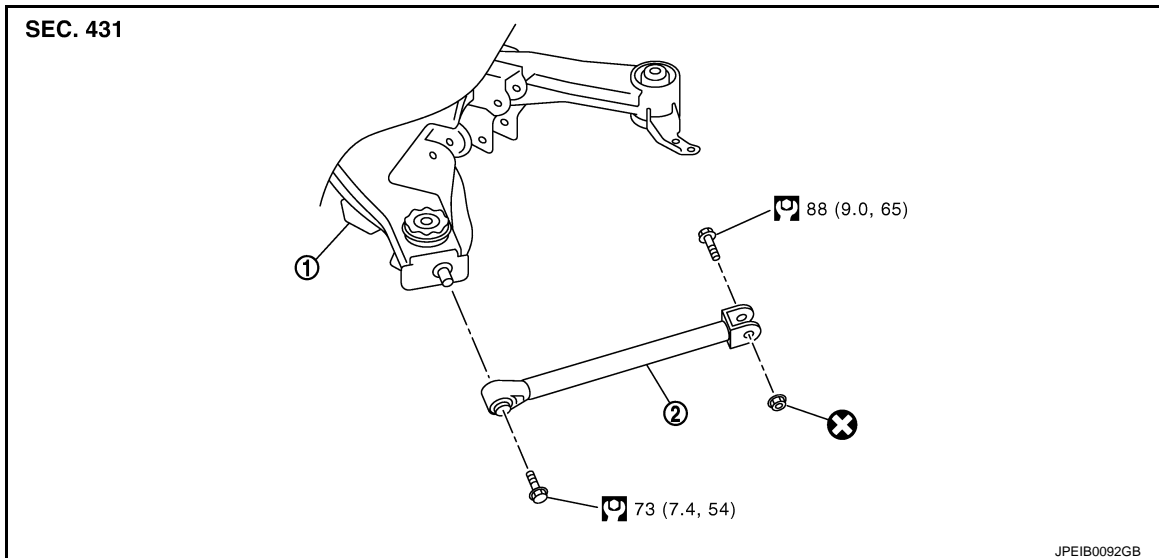

1. Rear suspension member
2. Radius rod

Refer to [GI-4. "Components"](#) for symbols in the figure.

### Removal and Installation

INFOID:000000006565889

#### REMOVAL

1. Remove tire with power tool.
2. Remove radius rod mounting bolt and nut (axle housing side) with power tool.
3. Remove radius rod mounting bolt (rear suspension member side) with power tool, and remove radius rod.

#### INSTALLATION

Note the following, and install in the reverse order of removal.

- Perform final tightening of rear suspension member and axle installation position (rubber bushing), under unladen conditions with tires on level ground.

#### Inspection

INFOID:000000006565890

#### INSPECTION AFTER REMOVAL

Check radius rod and bushing for any deformation, cracks, or damage. Replace it if necessary.

#### INSPECTION AFTER INSTALLATION

1. Check wheel alignment. Refer to [RSU-6. "Inspection"](#).
2. Adjust neutral position of steering angle sensor. Refer to [BRC-10. "ADJUSTMENT OF STEERING ANGLE SENSOR NEUTRAL POSITION : Special Repair Requirement"](#).

# FRONT LOWER LINK

< REMOVAL AND INSTALLATION >

## FRONT LOWER LINK

Exploded View

INFOID:000000006565891

WITHOUT RAS

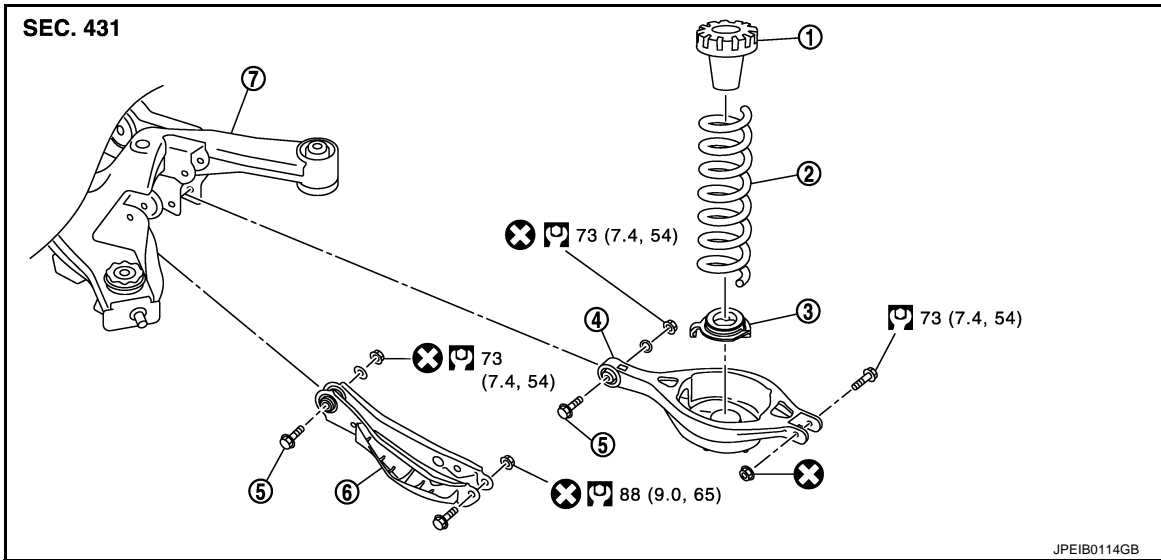

- |                           |                   |                     |
|---------------------------|-------------------|---------------------|
| 1. Upper seat             | 2. Coil spring    | 3. Rubber seat      |
| 4. Rear lower link        | 5. Adjusting bolt | 6. Front lower link |
| 7. Rear suspension member |                   |                     |

Refer to [GI-4, "Components"](#) for symbols in the figure.

WITH RAS

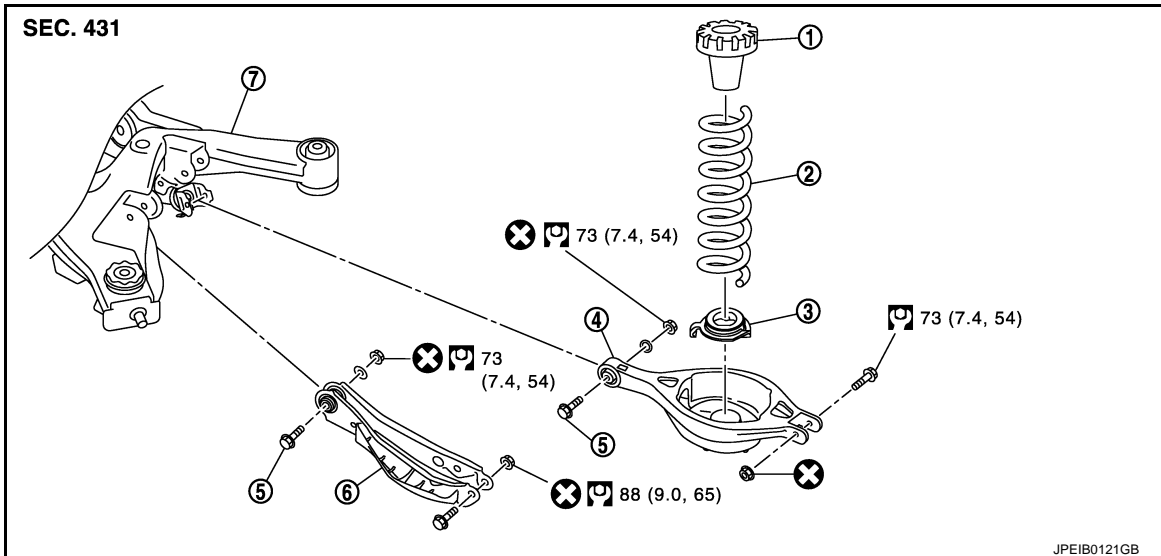

- |                           |                   |                     |
|---------------------------|-------------------|---------------------|
| 1. Upper seat             | 2. Coil spring    | 3. Rubber seat      |
| 4. Rear lower link        | 5. Adjusting bolt | 6. Front lower link |
| 7. Rear suspension member |                   |                     |

Refer to [GI-4, "Components"](#) for symbols in the figure.

## Removal and Installation

INFOID:000000006565892

### REMOVAL



# FRONT LOWER LINK

## < REMOVAL AND INSTALLATION >

---

1. Remove tire with power tool.
2. Set suitable jack under axle assembly to relieve the coil spring tension.
3. Remove shock absorber mounting bolts from front lower link. Refer to [RSU-10, "Exploded View"](#).
4. Remove front lower link mounting bolts and nuts from axle housing with power tool.
5. Remove stabilizer clamp and stabilizer bushing. Refer to [RSU-18, "Exploded View"](#).
6. Remove front lower link mounting bolts and nuts from rear suspension member with power tool, and remove front lower link.

## INSTALLATION

Note the following, and install in the reverse order of removal.

- Perform final tightening of rear suspension member and axle installation position (rubber bushing), under unladen conditions with tires on level ground.

## Inspection

INFOID:000000006565893

RSU

## INSPECTION AFTER REMOVAL

Check front lower link and bushing for any deformation, cracks, or damage. Replace it if necessary.

## INSPECTION AFTER INSTALLATION

1. Check wheel alignment. Refer to [RSU-6, "Inspection"](#).
2. Adjust neutral position of steering angle sensor. Refer to [BRC-10, "ADJUSTMENT OF STEERING ANGLE SENSOR NEUTRAL POSITION : Special Repair Requirement"](#).

# REAR STABILIZER

< REMOVAL AND INSTALLATION >

## REAR STABILIZER

Exploded View

INFOID:000000006565894

STABILIZER CLAMP FIXING METHOD : NUT

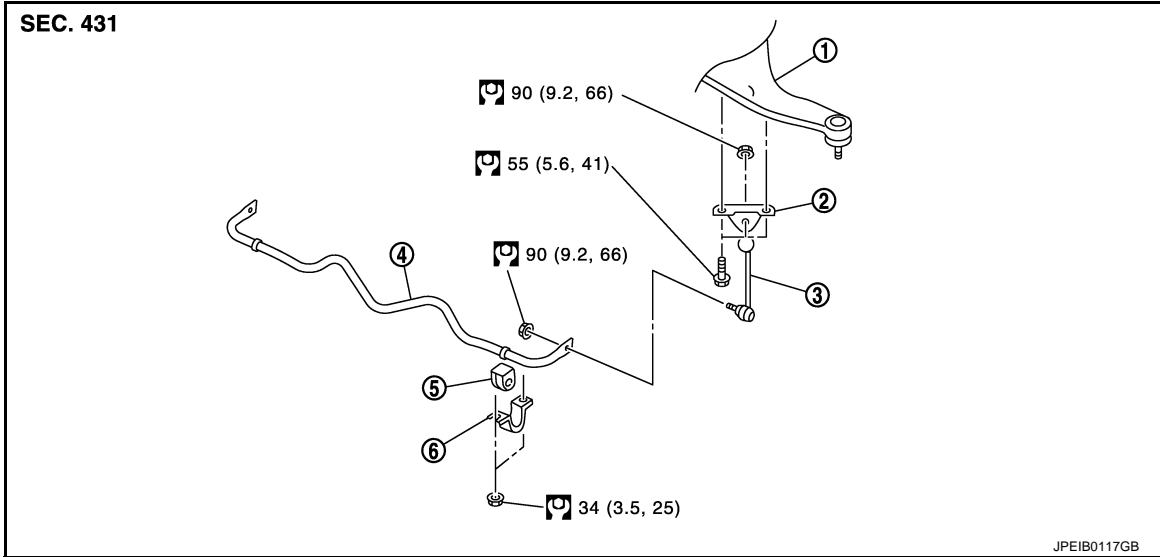

- |                   |   |                                      |
|-------------------|---|--------------------------------------|
| 1. Suspension arm | 2. Stabilizer connecting rod mounting bracket | 3. Stabilizer connecting rod bracket |
| 4. Stabilizer bar | 5. Stabilizer bushing                         | 6. Stabilizer clamp                  |

Refer to [GI-4. "Components"](#) for symbols in the figure.

STABILIZER CLAMP FIXING METHOD : BOLT

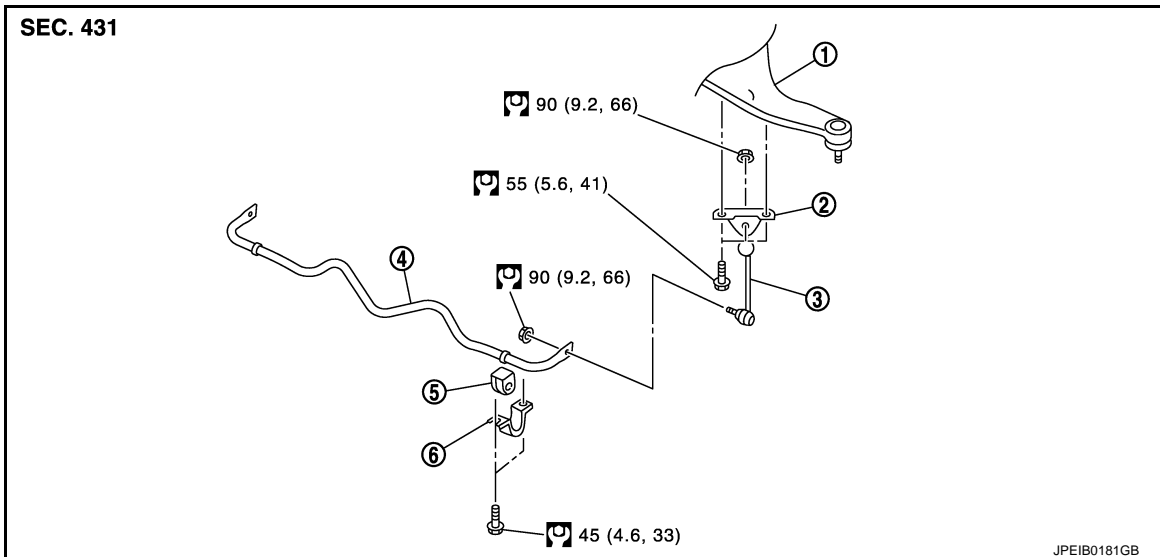

- |                   |   |                                      |
|-------------------|---|--------------------------------------|
| 1. Suspension arm | 2. Stabilizer connecting rod mounting bracket | 3. Stabilizer connecting rod bracket |
| 4. Stabilizer bar | 5. Stabilizer bushing                         | 6. Stabilizer clamp                  |

Refer to [GI-4. "Components"](#) for symbols in the figure.

## Removal and Installation

INFOID:000000006565895

### REMOVAL

# REAR STABILIZER

## < REMOVAL AND INSTALLATION >

1. Remove center muffler. Refer to [EX-5. "Exploded View"](#) (VQ35HR), [EX-10. "Exploded View"](#) (VK50VE). A
2. Remove under cover. B
3. Remove stabilizer connecting rod mounting nuts (lower side) with power tool, and remove stabilizer connecting rod from stabilizer bar. C
4. Remove stabilizer connecting rod mounting nuts (upper side) with power tool, and remove stabilizer connecting rod from stabilizer connecting rod mounting bracket. D
5. Remove mounting bolts or nuts on stabilizer clamp with power tool, and remove stabilizer bar. E
6. Remove stabilizer connecting rod mounting bracket. F

## INSTALLATION

Note the following, and install in the reverse order of removal.

- Tighten the mounting nut to the specified torque while holding a hexagonal part of stabilizer connecting rod side. G

## Inspection

INFOID:000000006565896

RSU

## INSPECTION AFTER REMOVAL

Check stabilizer bar, stabilizer connecting rod, stabilizer bushing and stabilizer clamp for deformation, cracks or damage. Replace it if necessary. H

I

J

K

L

M

N

O

P

Q

R

S

# REAR SUSPENSION MEMBER

< UNIT REMOVAL AND INSTALLATION >

## UNIT REMOVAL AND INSTALLATION

### REAR SUSPENSION MEMBER

Exploded View

INFOID:000000006565897

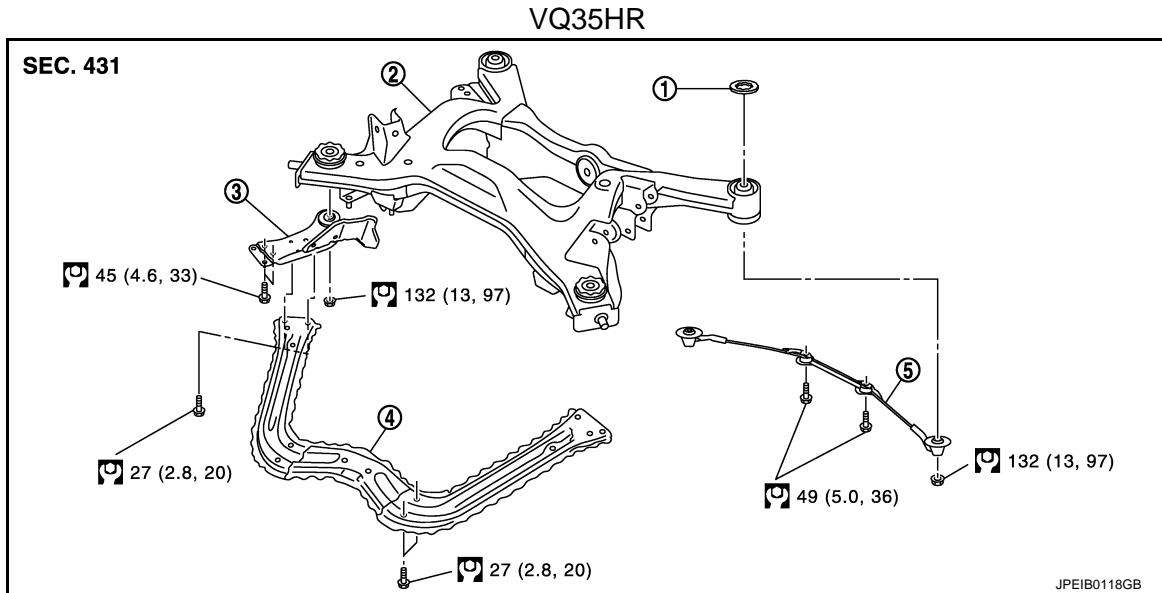

1. Mount stopper
2. Rear suspension member
3. Rear suspension member stay
4. Tunnel stay
5. Pin stay

Refer to [GI-4, "Components"](#) for symbols in the figure.

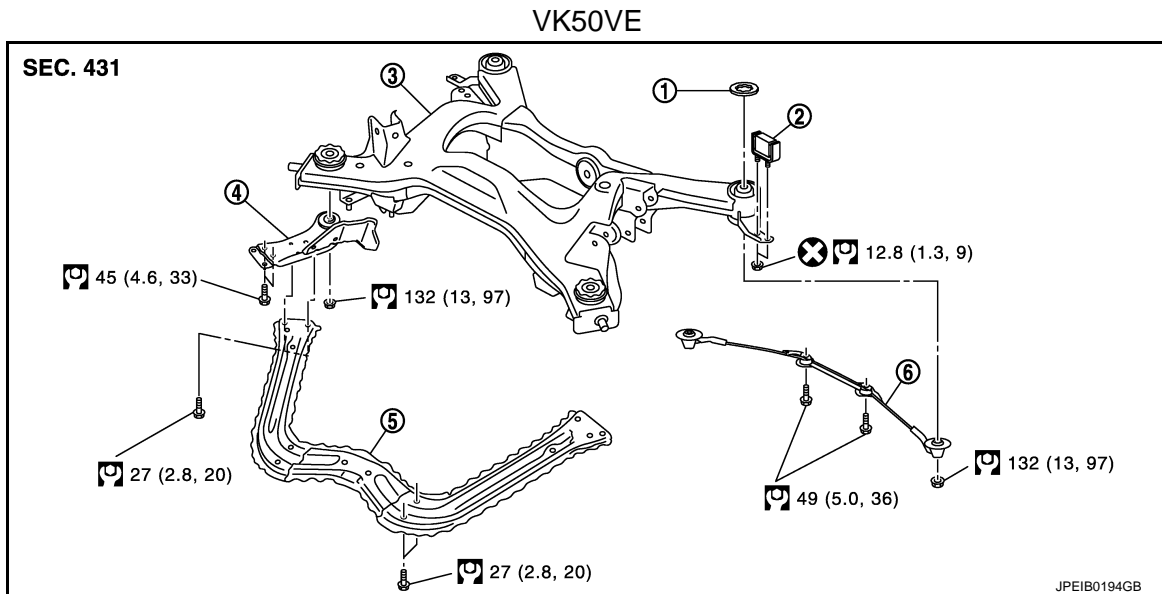

1. Mount stopper
2. Dynamic damper
3. Rear suspension member
4. Rear suspension member stay
5. Tunnel stay
6. Pin stay

Refer to [GI-4, "Components"](#) for symbols in the figure.

## Removal and Installation

INFOID:000000006565898

### REMOVAL

1. Remove tires with power tool.
2. Remove center muffler. Refer to [EX-5, "Exploded View"](#) (VQ35HR), [EX-10, "Exploded View"](#) (VK50VE).

# REAR SUSPENSION MEMBER

## < UNIT REMOVAL AND INSTALLATION >

3. Remove radius rod. Refer to [RSU-15. "Exploded View"](#).
4. Remove caliper assembly. Hang caliper assembly in a place where it will not interfere with work. Refer to [BR-56. "BRAKE CALIPER ASSEMBLY \(1 PISTON TYPE\) : Exploded View"](#) (1 piston type), [BR-60. "BRAKE CALIPER ASSEMBLY \(2 PISTON TYPE\) : Exploded View"](#) (2 piston type).  
**CAUTION:**  
**Avoid depressing brake pedal while brake caliper is removed.**
5. Remove disc rotor. Refer to [BR-57. "BRAKE CALIPER ASSEMBLY \(1 PISTON TYPE\) : Removal and Installation"](#) (1 piston type), [BR-61. "BRAKE CALIPER ASSEMBLY \(2 PISTON TYPE\) : Removal and Installation"](#) (2 piston type).
6. Remove wheel sensor harness from rear suspension member. Refer to [BRC-151. "REAR WHEEL SENSOR : Exploded View"](#).
7. Remove height sensor harness from rear suspension member (with xenon head lamp). Refer to [EXL-313. "Exploded View"](#).
8. Remove shock absorber actuator harness connector (with Continuous Damping Control).
9. Remove stabilizer bar. Refer to [RSU-18. "Exploded View"](#).
10. Remove drive shaft. Refer to [RAX-10. "Exploded View"](#).
11. Remove propeller shaft. Refer to [DLN-126. "Exploded View"](#) (3S80AR), [DLN-135. "Exploded View"](#) (3F80AR-1VL107), [DLN-144. "Exploded View"](#) (3F-R-2VL107).
12. Remove final drive. Refer to [DLN-219. "2WD : Exploded View"](#) [R200 (2WD)], [DLN-221. "AWD : Exploded View"](#) [R200 (AWD)], [DLN-282. "Exploded View"](#) (R230).
13. Remove parking brake cable mounting bolt and separate parking brake cable from vehicle and rear suspension member. Refer to [PB-5. "Exploded View"](#).
14. Remove shock absorber mounting bolts (lower side). Refer to [RSU-10. "Exploded View"](#).
15. Remove rear lower link and coil spring. Refer to [RSU-8. "Exploded View"](#).
16. Remove RAS actuator assembly (with RAS). Refer to [STC-129. "Exploded View"](#).
17. Set suitable jack under rear suspension member.
18. Remove pin stay.
19. Remove dynamic dampers. (VK50VE)
20. Remove tunnel stay.
21. Remove rear suspension member stay.
22. Slowly lower jack, then remove rear suspension member, suspension arm, front lower link, wheel hub and housing from vehicle as a unit.
23. Remove mounting bolts and nuts, then remove suspension arm, front lower link, wheel hub and housing from rear suspension member. Refer to [RSU-13. "Exploded View"](#), [RSU-16. "Exploded View"](#), [RAX-7. "Exploded View"](#)

## INSTALLATION

Note the following, and install in the reverse order of the removal.

- Perform the final tightening of each of parts under unladen conditions, which were removed when removing rear suspension assembly.
- Check wheel sensor harness for proper connection. Refer to [BRC-151. "REAR WHEEL SENSOR : Exploded View"](#).
- Never reuse cotter pin.

## Inspection

INFOID:000000006565899

## INSPECTION AFTER REMOVAL

Check rear suspension member for deformation, cracks, or any other damage. Replace if necessary.

## INSPECTION AFTER INSTALLATION

1. Check shock absorber actuator harness connector for proper connection (with Continuous Damping Control).
2. Adjust parking brake operation (stroke). Refer to [PB-3. "Inspection and Adjustment"](#).
3. Check wheel alignment. Refer to [RSU-6. "Inspection"](#).

## REAR SUSPENSION MEMBER

< UNIT REMOVAL AND INSTALLATION >

---

4. Adjust neutral position of steering angle sensor. Refer to [BRC-10. "ADJUSTMENT OF STEERING ANGLE SENSOR NEUTRAL POSITION : Special Repair Requirement"](#).

# SERVICE DATA AND SPECIFICATIONS (SDS)

< SERVICE DATA AND SPECIFICATIONS (SDS)

## SERVICE DATA AND SPECIFICATIONS (SDS)

### SERVICE DATA AND SPECIFICATIONS (SDS)

#### Wheel Alignment

INFOID:0000000006565900

Item		Standard		
Tire size		265/60R18	265/50R20	265/45R21
Camber Degree minute (Decimal degree)	Minimum	-1° 40' (-1.66°)		
	Nominal	-1° 10' (-1.16°)		
	Maximum	-0° 40' (-0.67°)		
Toe-in	Total toe-in Distance	Minimum	0 mm (0 in)	
		Nominal	In 3.2 mm (0.126 in)	In 3.1 mm (0.122 in)
		Maximum	In 6.4 mm (0.252 in)	In 6.2 mm (0.244 in)
	Toe angle (left wheel or right wheel) Degree minute (Decimal degree)	Minimum	0° 00' (0.00°)	
		Nominal	In 0° 07' (0.12°)	
		Maximum	In 0° 14' (0.23°)	

Measure value under unladen\* conditions.

\*: Fuel, engine coolant and lubricant are full. Spare tire, jack, hand tools and mats are in designated positions.

#### Ball Joint

INFOID:0000000006565901

Item	Standard
Swing torque	0.5 – 3.4 N·m (0.06 – 0.34 kg·m, 5 – 30 in·lb)
Measurement on spring balance (cotter pinhole position)	8.1 – 54.8 N (0.83 – 5.59 kg, 1.83 – 12.31 lb)
Rotating torque	0.5 – 3.4 N·m (0.06 – 0.34 kg·m, 5 – 30 in·lb)
Axial end play	0 mm (0 in)

#### Wheel Height

INFOID:0000000006565902

Applied model	2WD		AWD		
Tire	265/60R18	265/50R20	265/60R18	265/50R20	265/45R21
Rear (Hr)	831 mm (32.72 in)		830 mm (32.68 in)		831 mm (32.72 in)

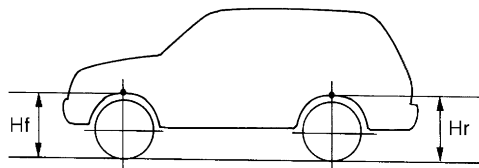

SFA746B

Measure value under unladen\* conditions.

\*: Fuel, engine coolant and lubricant are full. Spare tire, jack, hand tools and mats are in designated positions.