

A

# SECTION ACC

ACC

## ACCELERATOR CONTROL SYSTEM

C

### CONTENTS

D

E

<b>PRECAUTIONS</b> .....	<b>2</b>	<b>Components</b> .....	<b>3</b>	F
Precautions for Supplemental Restraint System (SRS) "AIR BAG" and "SEAT BELT PRE-TEN- SIONER" .....	2	<b>Removal and Installation</b> .....	3	
<b>ACCELERATOR CONTROL SYSTEM</b> .....	<b>3</b>	<b>REMOVAL</b> .....	3	
		<b>INSTALLATION</b> .....	3	G
		<b>INSPECTION AFTER INSTALLATION</b> .....	3	

H

I

J

K

L

M

# PRECAUTIONS

---

## PRECAUTIONS

PF0:00001

### Precautions for Supplemental Restraint System (SRS) “AIR BAG” and “SEAT BELT PRE-TENSIONER”

NBS004IP

The Supplemental Restraint System such as “AIR BAG” and “SEAT BELT PRE-TENSIONER”, used along with a front seat belt, helps to reduce the risk or severity of injury to the driver and front passenger for certain types of collision. This system includes seat belt switch inputs and dual stage front air bag modules. The SRS system uses the seat belt switches to determine the front air bag deployment, and may only deploy one front air bag, depending on the severity of a collision and whether the front occupants are belted or unbelted. Information necessary to service the system safely is included in the SRS and SB section of this Service Manual.

#### **WARNING:**

- To avoid rendering the SRS inoperative, which could increase the risk of personal injury or death in the event of a collision which would result in air bag inflation, all maintenance must be performed by an authorized NISSAN/INFINITI dealer.
- Improper maintenance, including incorrect removal and installation of the SRS, can lead to personal injury caused by unintentional activation of the system. For removal of Spiral Cable and Air Bag Module, see the SRS section.
- Do not use electrical test equipment on any circuit related to the SRS unless instructed to in this Service Manual. SRS wiring harnesses can be identified by yellow and/or orange harnesses or harness connectors.

# ACCELERATOR CONTROL SYSTEM

## ACCELERATOR CONTROL SYSTEM

PFP:18005

### Components

NBS0041Q

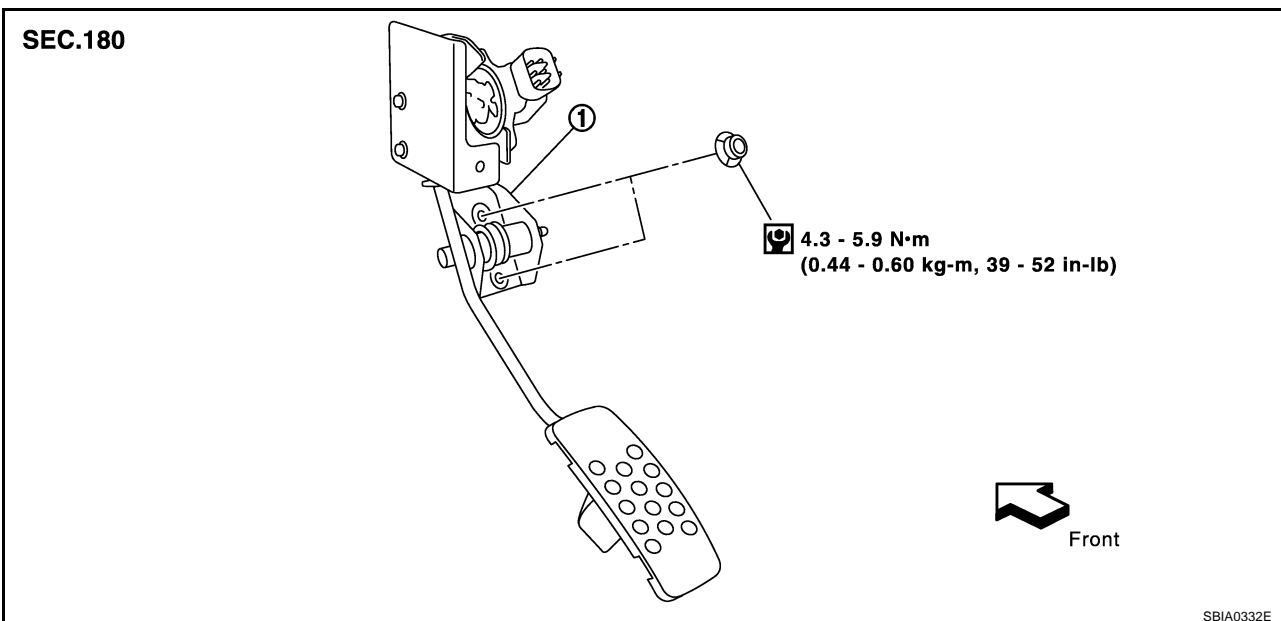

1. Accelerator pedal assembly

## Removal and Installation

NBS005S6

### REMOVAL

1. Disconnect accelerator pedal position sensor harness connector.
2. Loosen mounting nuts, and remove accelerator pedal assembly.

#### CAUTION:

- Do not disassemble accelerator pedal assembly. Do not remove accelerator pedal position sensor from accelerator pedal assembly.
- Avoid impact from dropping etc. during handling.
- Be careful to keep accelerator pedal assembly away from water.

### INSTALLATION

Installation is the reverse order of removal.

### INSPECTION AFTER INSTALLATION

- Make sure accelerator pedal moves smoothly within the whole operation range when it is fully depressed and released.
- Make sure accelerator pedal securely returns to the fully released position.
- For the electrical inspection of accelerator pedal position sensor, refer to the following.
  - VQ35DE  
[EC-576, "DTC P2122, P2123 APP SENSOR"](#), [EC-583, "DTC P2127, P2128 APP SENSOR"](#) and [EC-597, "DTC P2138 APP SENSOR"](#)
  - VK45DE  
[EC-1258, "DTC P2122, P2123 APP SENSOR"](#), [EC-1265, "DTC P2127, P2128 APP SENSOR"](#) and [EC-1279, "DTC P2138 APP SENSOR"](#)

#### CAUTION:

When harness connector of accelerator pedal position sensor is disconnected, perform "Accelerator Pedal Released Position Learning". Refer to [EC-83, "Accelerator Pedal Released Position Learning"](#) (VQ35DE) or [EC-745, "Accelerator Pedal Released Position Learning"](#) (VK45DE).

# ACCELERATOR CONTROL SYSTEM

---