

SECTION **FSU**
FRONT SUSPENSION

A
B
C
D
E
F
G
H
I
J
K
L
M
N
O
P

FSU

CONTENTS

SERVICE INFORMATION	2	COIL SPRING AND STRUT	10
PRECAUTIONS	2	Removal and Installation	10
Caution	2	Disassembly and Assembly	11
PREPARATION	3	TRANSVERSE LINK	13
Special Service Tool	3	Removal and Installation	13
Commercial Service Tool	3	STABILIZER BAR	15
NOISE, VIBRATION AND HARSHNESS		Removal and Installation	15
(NVH) TROUBLESHOOTING	4	FRONT SUSPENSION MEMBER	16
NVH Troubleshooting Chart	4	Removal and Installation	16
FRONT SUSPENSION ASSEMBLY	5	SERVICE DATA AND SPECIFICATIONS	
On-Vehicle Inspection and Service	5	(SDS)	17
Wheel Alignment Inspection	5	Wheel Alignment (Unladen*)	17
Removal and Installation	6	Ball Joint	17
		Wheelarch Height (Unladen*)	17

PRECAUTIONS

< SERVICE INFORMATION >

SERVICE INFORMATION

PRECAUTIONS

Caution

INFOID:000000001327533

- When installing rubber bushings, final tightening must be carried out under unladen conditions with tires on ground. Oil will shorten the life of rubber bushings. Be sure to wipe off any spilled oil.
- Unladen conditions mean that fuel, engine coolant and lubricant are full. Spare tire, jack, hand tools and mats are in designated positions.
- After servicing suspension parts, be sure to check wheel alignment.
- Caulking nuts are not reusable. Always use new ones when installing. Since new caulking nuts are pre-oiled, tighten as they are.
- Avoid burden to front cross bar.

PREPARATION

< SERVICE INFORMATION >

PREPARATION

Special Service Tool

INFOID:000000001327534

The actual shapes of Kent-Moore tools may differ from those of special service tools illustrated here.

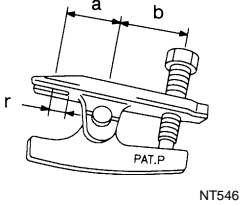
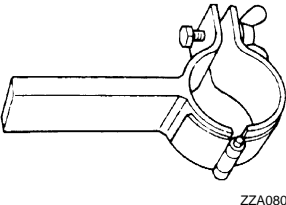
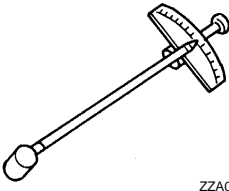
Tool number (Kent-Moore No.) Tool name	Description
HT72520000 (J-25730-A) Ball joint remover a: 33 mm (1.30 in) b: 50 mm (1.97 in) r: 11.5 mm (0.453 in)	 <ul style="list-style-type: none"> • Removing steering outer socket • Removing transverse link
ST35652000 (—) Strut attachment	 <p>Disassembling and assembling strut</p>
ST3127 S000 (See J-25765-A) Preload gauge	 <p>Measuring rotating torque of ball joint</p>

Commercial Service Tool

INFOID:000000001327535

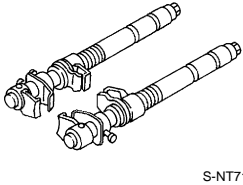
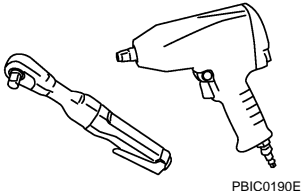
Tool name	Description
Spring compressor	 <p>Removing coil spring</p>
Power tool	 <p>Loosening bolts and nuts</p>

NOISE, VIBRATION AND HARSHNESS (NVH) TROUBLESHOOTING

< SERVICE INFORMATION >

NOISE, VIBRATION AND HARSHNESS (NVH) TROUBLESHOOTING

NVH Troubleshooting Chart

INFOID:000000001327536

Use chart below to help you find the cause of the symptom. If necessary, repair or replace these parts.

Symptom		Possible cause and SUSPECTED PARTS	Reference page																
			FSU-6	FSU-11	—	—	—	FSU-6	FSU-5	FSU-15	NVH in PR section	NVH in RFD section	NVH in FAX and FSU section	NVH in WT section	NVH in WT section	NVH in FAX section	NVH in BR section	NVH in PS section	
Symptom	FRONT SUSPENSION	Noise	x	x	x	x	x	x			x	x	x	x	x	x	x	x	
		Shake	x	x	x	x			x			x		x	x	x	x	x	
		Vibration	x	x	x	x	x					x		x	x				
		Shimmy	x	x	x	x				x				x	x	x		x	x
		Judder	x	x	x									x	x	x		x	x
		Poor quality ride or handling	x	x	x	x	x			x	x			x	x	x			
		Improper installation, looseness																	
		Strut deformation, damage or deflection																	
		Bushing or mounting deterioration																	
		Parts interference																	
		Spring fatigue																	
		Suspension looseness																	
		Incorrect wheel alignment																	
		Stabilizer bar fatigue																	
		PROPELLER SHAFT (For AWD models)																	
		DIFFERENTIAL (For AWD models)																	
		FRONT AXLE AND FRONT SUSPENSION																	
		TIRE																	
		ROAD WHEEL																	
		DRIVE SHAFT (For AWD models)																	
		BRAKE																	
		STEERING																	

x: Applicable

FRONT SUSPENSION ASSEMBLY

< SERVICE INFORMATION >

FRONT SUSPENSION ASSEMBLY

On-Vehicle Inspection and Service

INFOID:000000001327537

Make sure the mounting conditions (looseness, back lash) of each component and component conditions (wear, damage) are normal.

INSPECTION LOWER BALL JOINT END PLAY

1. Set front wheels in a straight-ahead position. Do not depress brake pedal.
2. Place an iron bar or similar tool between transverse link and steering knuckle.
3. Measure axial end play by prying it up and down.

Axial end play : 0 mm (0 in)

CAUTION:

Be careful not to damage ball joint boot.

STRUT INSPECTION

- Check strut for oil leakage, damage and replace if there are. Refer to [FSU-10](#).

Wheel Alignment Inspection

INFOID:000000001327538

DESCRIPTION

- Measure wheel alignment under unladen conditions.

NOTE:

Unladen conditions mean that fuel, engine coolant, and lubricant are full. Spare tire, jack, hand tools and mats are designated positions.

PRELIMINARY CHECK

- Check tires for improper air pressure and wear.
- Check road wheels for runout.
- Check wheel bearing axial end play.
- Check ball joint axial end play of compression rod, upper link, and steering knuckle
- Check shock absorber operation.
- Check each mounting part of axle and suspension for looseness and deformation.
- Check each link, rod and member for cracks, deformation and other damage.
- Check vehicle posture.

GENERAL INFORMATION AND RECOMMENDATIONS

- A four-wheel thrust alignment should be performed.
- This type of alignment is recommended for any NISSAN/INFINITI vehicle.
- The four-wheel "thrust" process helps ensure that the vehicle is properly aligned and the steering wheel is centered.
- The alignment rack itself should be capable of accepting any NISSAN/INFINITI vehicle.
- The rack should be checked to ensure that it is level.
- Make sure the machine is properly calibrated.
- Your alignment equipment should be regularly calibrated in order to give correct information.
- Check with the manufacturer of your specific equipment for their recommended Service/Calibration Schedule.

THE ALIGNMENT PROCESS

IMPORTANT:

Use only the alignment specifications listed in this Service Manual.

- When displaying the alignment settings, many alignment machines use "indicators": (Green/red, plus or minus, Go/No Go). **Do NOT use these indicators.**
- The alignment specifications programmed into your machine that operate these indicators may not be correct.
- This may result in an ERROR.
- Some newer alignment machines are equipped with an optional "Rolling Compensation" method to "compensate" the sensors (alignment targets or head units). **DO NOT use this "Rolling Compensation" method.**

A

B

C

D

FSU

F

G

H

I

J

K

L

M

N

O

P

FRONT SUSPENSION ASSEMBLY

< SERVICE INFORMATION >

- Use the "Jacking Compensation Method". After installing the alignment targets or head units, raise the vehicle and rotate the wheels 1/2 turn both ways.
- See Instructions in the alignment machine you're using for more information on this.

INSPECTION OF CAMBER, CASTER AND KINGPIN INCLINATION ANGLES

- Camber, caster, kingpin inclination angles cannot be adjusted.
- Before inspection, mount front wheels onto turning radius gauge. Mount rear wheels onto a stand that has same height so vehicle will remain horizontal.

Removal and Installation

INFOID:000000001327539

COMPONENTS

FRONT SUSPENSION ASSEMBLY

< SERVICE INFORMATION >

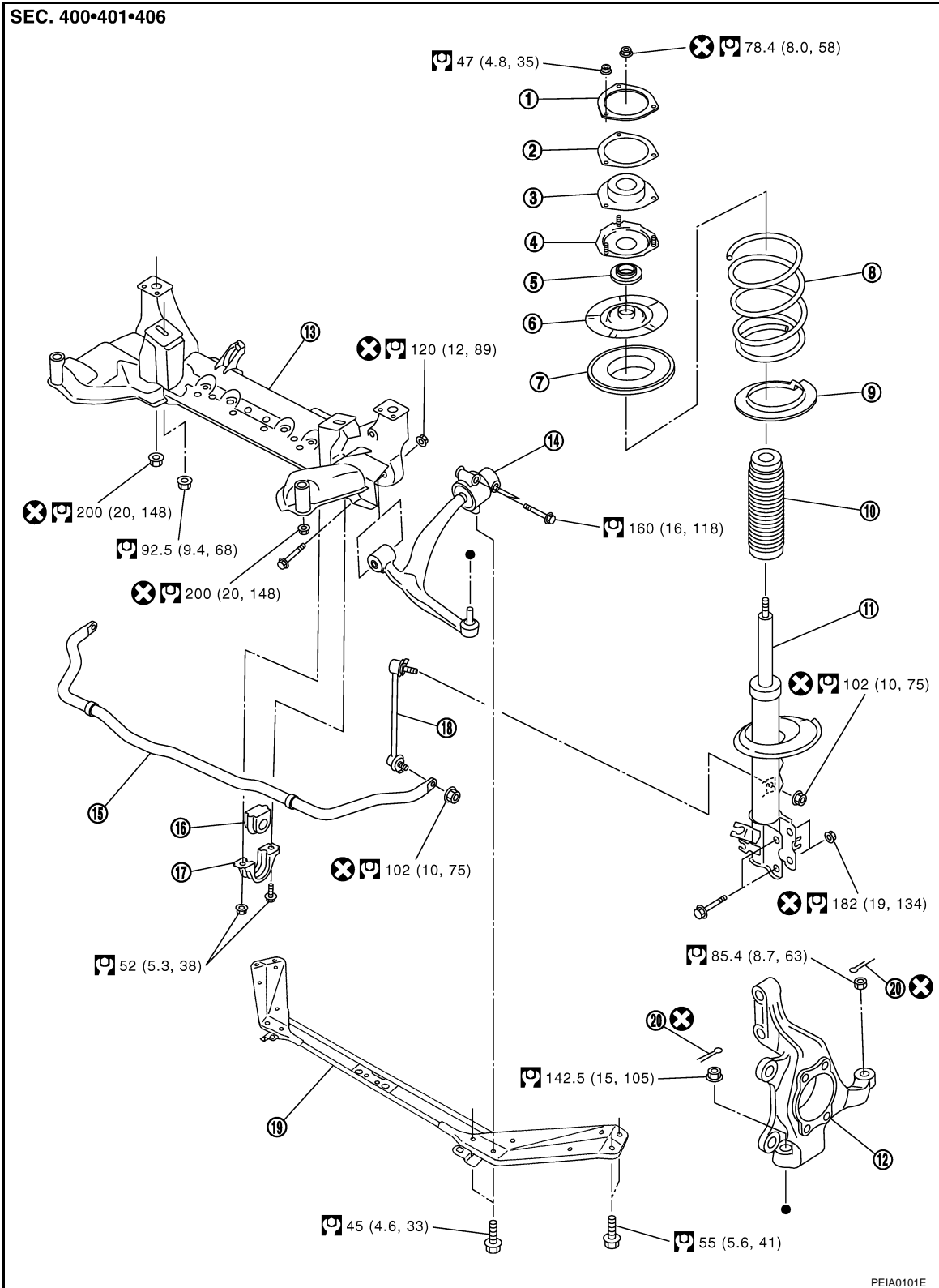

- | | | |
|-------------------------------|----------------------|-------------------------------|
| 1. Strut upper plate | 2. Strut spacer | 3. Mounting insulator |
| 4. Mounting insulator bracket | 5. Mounting bearing | 6. Spring upper seat |
| 7. Spring upper rubber seat | 8. Coil spring | 9. Spring lower rubber seat |
| 10. Bound bumper | 11. Strut | 12. Steering knuckle |
| 13. Front suspension member | 14. Transverse link | 15. Stabilizer bar |
| 16. Stabilizer bushing | 17. Stabilizer clamp | 18. Stabilizer connecting rod |

A
B
C
D
FSU
F
G
H
I
J
K
L
M
N
O
P

FRONT SUSPENSION ASSEMBLY

< SERVICE INFORMATION >

19. Front cross bar
20. Cotter pin
Refer to [GI-8, "Component"](#), for the symbols in the figure.

REMOVAL

1. Set an engine slinger to engine, then suspend engine.
2. Remove tire from vehicle with power tool.
3. Remove brake caliper with power tool. Hang it in a place where it will not interfere with work. Refer to [BR-18](#).
4. Remove brake hose lock plate. Then remove brake hose from strut assembly.
5. Remove disc rotor.
6. Remove wheel sensor harness from strut assembly.
CAUTION:
Do not pull on wheel sensor harness.
7. Remove undercover with power tool.
8. Remove front cross bar.
9. Remove steering hydraulic piping bracket from front suspension member. Refer to [PS-37](#).
10. Remove cotter pin at steering outer socket, then loosen mounting nut.
11. Use a ball joint remover (SST) to remove steering outer socket from steering knuckle. Be careful not to damage ball joint boot.
CAUTION:
Tighten temporarily mounting nut to prevent damage to threads and to prevent ball joint remover (SST) from coming off.
12. Remove mounting bolts of steering gear with power tool, then hang steering gear on vehicle. Refer to [PS-17](#).
13. Remove front final drive side of drive shaft with power tool. (For AWD models) Refer to [FAX-15, "Removal and Installation \(Left Side\)"](#), [FAX-16, "Removal and Installation \(Right Side\)"](#).
14. Set jack under front suspension member.
15. Remove fixing bolts and nuts between strut assembly and steering knuckle with power tool.
16. Remove stabilizer connecting rod upper nut with power tool, separate stabilizer connecting rod and strut assembly.
17. Remove mounting nuts between engine mounting insulator and front suspension member.

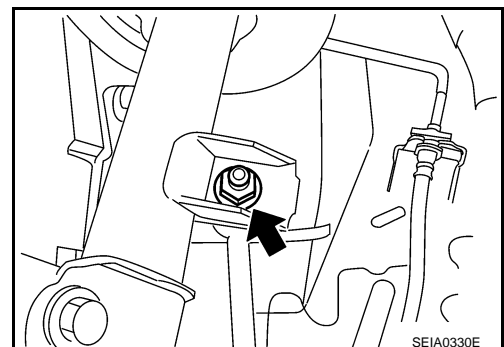
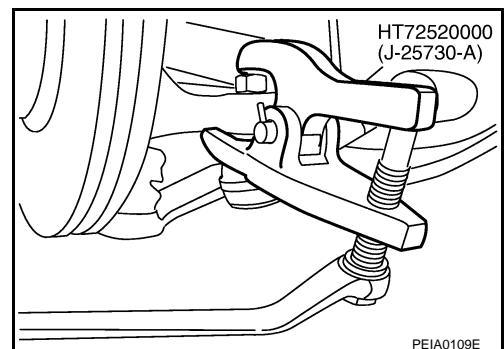
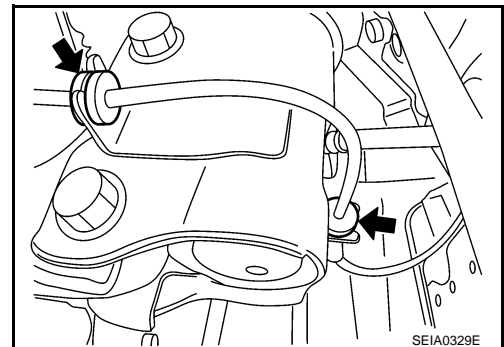
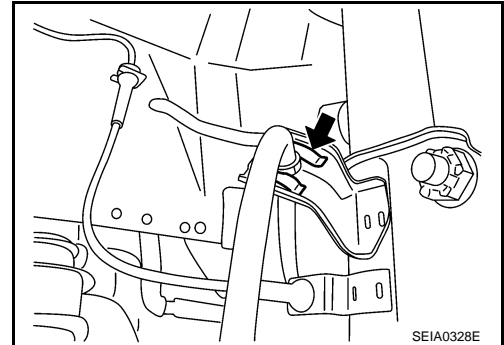

FRONT SUSPENSION ASSEMBLY

< SERVICE INFORMATION >

18. Remove mounting bolts which are at the back of transverse link (mounting part with body) with power tool, separate transverse link.
19. Remove mounting nuts between front suspension member and body with power tool.
20. Move jack down slowly to remove front suspension member, transverse link, stabilizer bar, drive shaft (For AWD models) and steering knuckle from vehicle as a unit.
21. Remove transverse link from steering knuckle. Refer to [FSU-13](#).

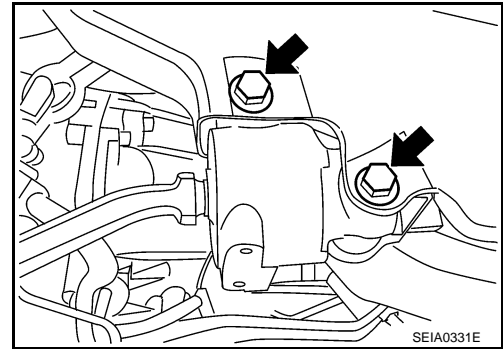

INSTALLATION

- Refer to "Removal and Installation" for tightening torque. Install in the reverse order of removal.

NOTE:

- Refer to component parts location and do not reuse non-reusable parts.
- After removing/installing or replacing suspension components and steering components, check wheel alignment. Refer to [FSU-5, "Wheel Alignment Inspection"](#).
- After adjusting wheel alignment, adjust neutral position of steering angle sensor. Refer to [BRC-8, "Adjustment of Steering Angle Sensor Neutral Position"](#).
- Check the following item after service.
 - Installation condition of wheel sensor harness.

A
B
C
D
F
G
H
I
J
K
L
M
N
O
P

FSU

COIL SPRING AND STRUT

< SERVICE INFORMATION >

COIL SPRING AND STRUT

Removal and Installation

INFOID:000000001327540

REMOVAL

1. Remove tires from vehicle with power tool.
2. Remove brake hose lock plate. Then remove brake hose from strut assembly.

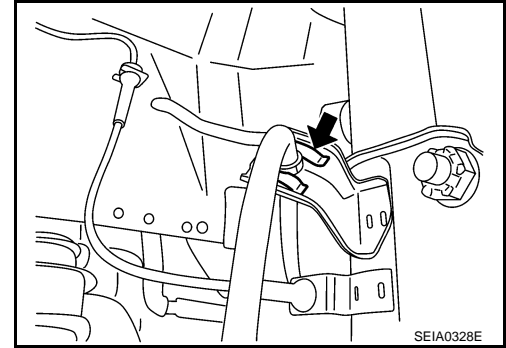

3. Remove wheel sensor harness from strut assembly.

CAUTION:
Do not pull wheel sensor harness.

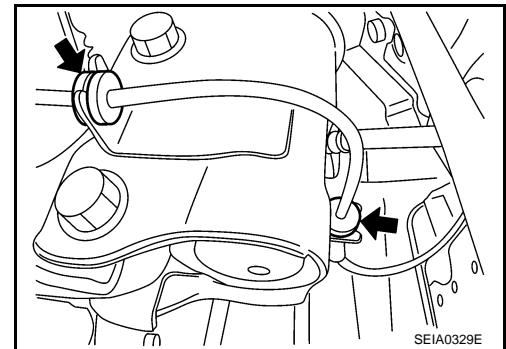

4. Remove stabilizer connecting rod upper nut with power tool, separate stabilizer connecting rod and strut assembly.
5. Remove fixing bolts and nuts between strut assembly and steering knuckle with power tool.
6. Remove mounting nuts on mounting insulator bracket with power tool, then remove strut upper plate, strut spacer and strut from vehicle.

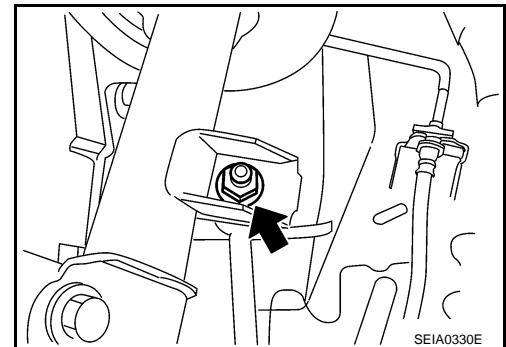

INSTALLATION

- Refer to [FSU-6. "Removal and Installation"](#) for tightening torque. Install in the reverse order of removal.

NOTE:

- Refer to component parts location and do not reuse non-reusable parts.
- After removing/installing or replacing suspension components, check wheel alignment. Refer to [FSU-5. "Wheel Alignment Inspection"](#).
- After adjusting wheel alignment, adjust neutral position of steering angle sensor. Refer to [BRC-8. "Adjustment of Steering Angle Sensor Neutral Position"](#).
- Check the following item after service.
 - Installation condition of wheel sensor harness.

COIL SPRING AND STRUT

< SERVICE INFORMATION >

- Attach strut upper plate as shown in the figure.

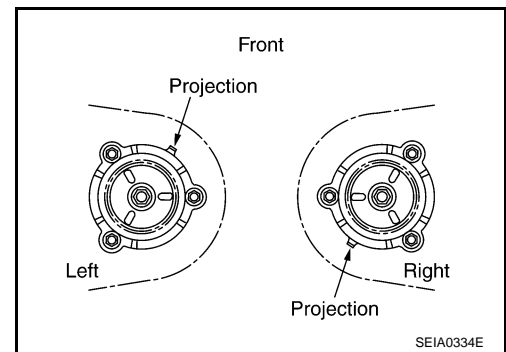

Disassembly and Assembly

INFOID:000000001327541

DISASSEMBLY

NOTE:

Make sure piston rod on strut is not damaged when removing components from strut assembly.

1. Install strut attachment (SST) to strut and fix it in a vise.

CAUTION:

When installing strut attachment (SST) to strut, wrap a shop cloth around strut to protect it from damage.

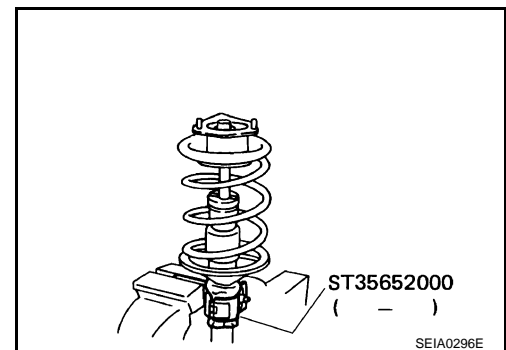

2. Using a spring compressor (commercial service tool), compress coil spring between spring upper seat and spring lower seat (on strut) until coil spring is free.

CAUTION:

Be sure spring compressor (commercial service tool) is securely attached to coil spring. Compress coil spring.

3. After making sure coil spring is free between spring upper seat and spring lower seat of strut, then remove piston rod lock nut.
4. Remove mounting insulator, mounting insulator bracket, mounting bearing, spring upper seat, spring upper rubber seat, bound bumper. Then remove coil spring and spring lower rubber seat from strut.

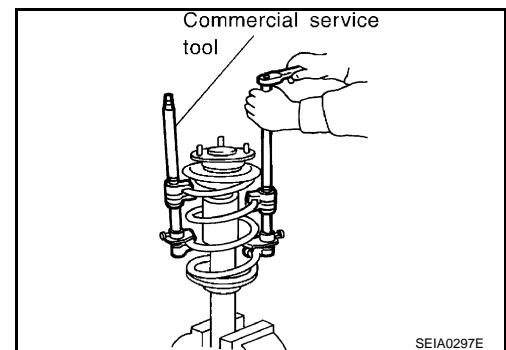

5. Gradually release spring compressor (commercial service tool), and remove coil spring.

CAUTION:

Loosen spring compressor while making sure coil spring attachment position does not move.

6. Remove strut attachment (SST) from strut.

INSPECTION AFTER DISASSEMBLY

Strut Inspection

- Check strut for deformation, cracks, damage, and replace if necessary.
- Check piston rod for damage, uneven wear or distortion, and replace if necessary.
- Check welded and sealed areas for oil leakage, and replace if necessary.

Mounting Insulator and Rubber Parts Inspection

Check mounting insulator for cracks and rubber parts for wear. Replace them if necessary.

Coil Spring Inspection

Check coil spring for cracks, wear or damage, and replace if necessary.

ASSEMBLY

NOTE:

A
B
C
D
FSU
F
G
H
I
J
K
L
M
N
O
P

COIL SPRING AND STRUT

< SERVICE INFORMATION >

Make sure piston rod on strut is not damaged when attaching components to strut.

1. Install strut attachment (SST) to strut and fix it in a vise.

CAUTION:

When installing strut attachment (SST) to strut, wrap a shop cloth around strut to protect it from damage.

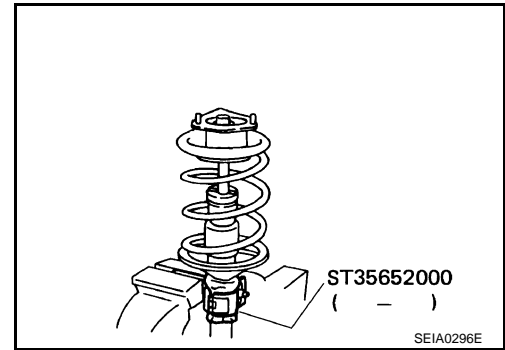

2. Compress coil spring using a spring compressor (commercial service tool), and install it onto strut.

CAUTION:

- Face tube side of coil spring downward. Align lower end to spring rubber seat as shown in the figure.
- Be sure spring compressor (commercial service tool) is securely attached to coil spring. Compress coil spring.

3. Apply soapy water to bound bumper and insert into mounting insulator.

CAUTION:

Do not use machine oil.

4. Install mounting insulator bracket, mounting bearing, bound bumper, spring upper seat, spring upper rubber seat and spring lower rubber seat.

- Installation position of spring upper seat is as shown in the figure.

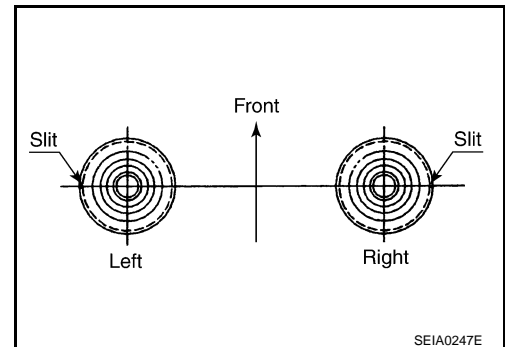
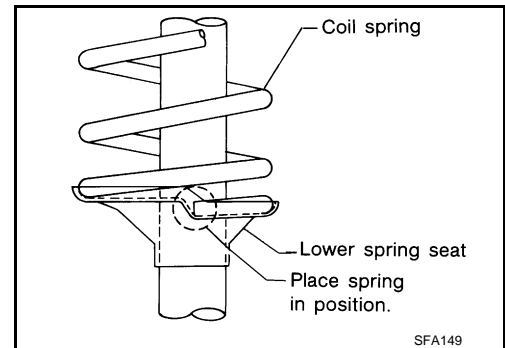

5. Fix mounting insulator, then tighten piston rod lock nut with specified torque.

CAUTION:

Be careful not to deform mounting insulator bracket.

6. Gradually release spring compressor (commercial service tool), and remove coil spring.

CAUTION:

Loosen spring compressor while making sure coil spring attachment position does not move.

7. Remove strut attachment (SST) from strut.

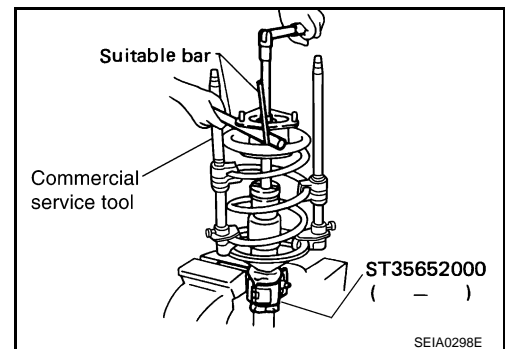

TRANSVERSE LINK

< SERVICE INFORMATION >

TRANSVERSE LINK

Removal and Installation

INFOID:000000001327542

REMOVAL

1. Remove tire from vehicle with power tool.
2. Remove undercover with power tool.
3. Remove front cross bar.
4. Remove cotter pin at transverse link, then loosen mounting nut.
5. Use a ball joint remover (SST) to remove transverse link from steering knuckle. Be careful not to damage ball joint boot.

CAUTION:

Tighten temporarily mounting nut to prevent damage to threads and to prevent ball joint remover (SST) from coming off.

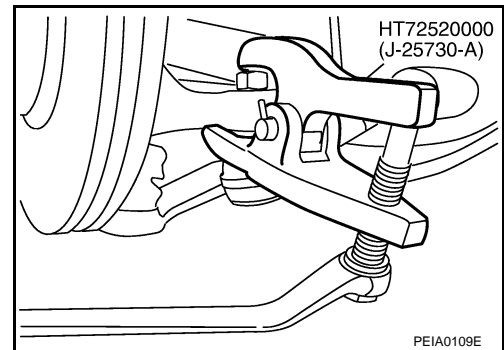

6. Remove mounting bolts which are at the back of transverse link (mounting part with body) with power tool, separate transverse link.
7. Remove mounting bolts which are at the front of transverse link (mounting part with front suspension member) with power tool, separate transverse link.
8. Remove transverse link from vehicle.

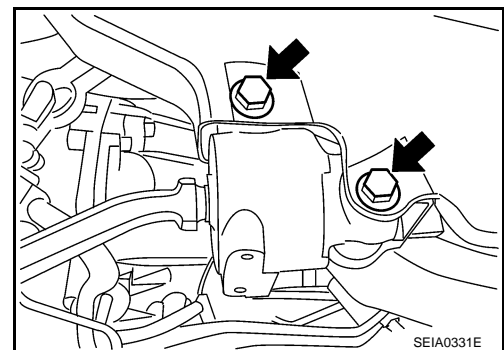

INSPECTION AFTER REMOVAL

Visual Inspection

- Check transverse link and bushing for deformation, cracks, or damage. If any non-standard condition is found, replace it.
- Check boot of ball joint for cracks, or other damage, and also for grease leakage. If any non-standard condition is found, replace it.

Ball Joint Inspection

Manually move ball stud to confirm it moves smoothly with no binding.

Swing Torque Inspection

NOTE:

Before measurement, move ball joint at least ten times by hand to check for smooth movement.

- Hook spring balance at ball stud. Confirm spring balance measurement value is within the specifications when ball stud begins moving.

Swing torque:

Less than 0.5 – 4.9 N·m (0.06 – 0.49 kg·m, 5 – 43 in-lb)

Measure value of spring scale:

Less than 0.5 – 4.9 N·m (0.06 – 0.49 kg·m, 5 – 43 in-lb)

- If it is outside the specified range, replace transverse link assembly.

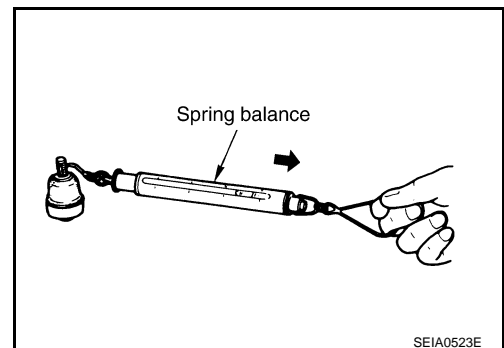

Rotating Torque Inspection

A
B
C
D
FSU
F
G
H
I
J
K
L
M
N
O
P

TRANSVERSE LINK

< SERVICE INFORMATION >

- Attach mounting nut to ball stud. Check that rotating torque is within the specifications with a preload gauge (SST).

Rotating Torque:

Less than 0.5 – 4.9 N·m (0.06 – 0.49 kg·m, 5 – 43 in·lb)

- If it is outside the specified range, replace transverse link assembly.

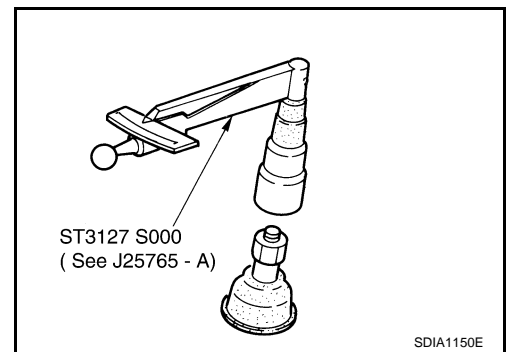

Axial End Play Inspection

- Move tip of ball joint in axial direction to check for looseness.

Axial end play : 0.1 mm (0.004 in)

- If it is outside the specified range, replace transverse link assembly.

INSTALLATION

- Refer to [FSU-6, "Removal and Installation"](#) for tightening torque. Install in the reverse order of removal.

NOTE:

Refer to component parts location and do not reuse non-reusable parts.

- After removing/installing or replacing suspension components, check wheel alignment. Refer to [FSU-5, "Wheel Alignment Inspection"](#).
- After adjusting wheel alignment, adjust neutral position of steering angle sensor. Refer to [BRC-8, "Adjustment of Steering Angle Sensor Neutral Position"](#).

STABILIZER BAR

< SERVICE INFORMATION >

STABILIZER BAR

Removal and Installation

INFOID:000000001327543

REMOVAL

1. Remove tires from vehicle with power tool.
2. Remove undercover with power tool.
3. Remove stabilizer connecting rod lower nut with power tool, separate stabilizer bar and stabilizer connecting rod.
4. Remove stabilizer clamp mounting bolts and nuts with power tool.
5. Remove stabilizer bar, stabilizer clamp, stabilizer bushing from vehicle.

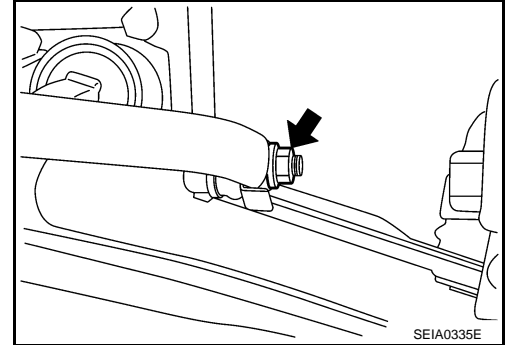

6. Remove stabilizer connecting rod upper nut with power tool, separate stabilizer connecting rod and strut.

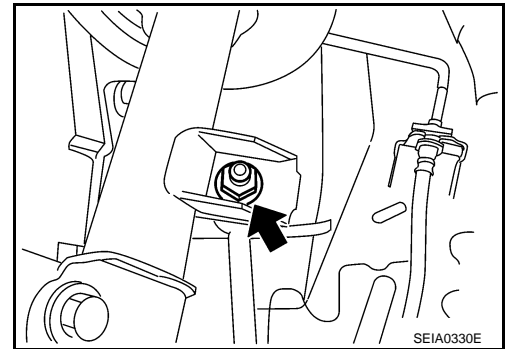

INSPECTION AFTER REMOVAL

Check stabilizer bar, stabilizer connecting rod, stabilizer bushing and stabilizer clamp deformation, cracks and damage, and replace if necessary.

INSTALLATION

- Refer to [FSU-6, "Removal and Installation"](#) for tightening torque. Install in the reverse order of removal.
- NOTE:**
Refer to component parts location and do not reuse non-reusable parts.
- After removing/installing or replacing suspension components, check wheel alignment. Refer to [FSU-5, "Wheel Alignment Inspection"](#).
- After adjusting wheel alignment, adjust neutral position of steering angle sensor. Refer to [BRC-8, "Adjustment of Steering Angle Sensor Neutral Position"](#).
- Stabilizer bar uses pillow ball type connecting rod. Position ball joint with case on pillow ball head parallel to stabilizer bar.

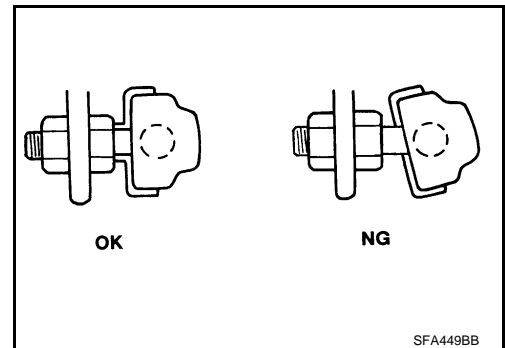

A
B
C
D
FSU
F
G
H
I
J
K
L
M
N
O
P

FRONT SUSPENSION MEMBER

< SERVICE INFORMATION >

FRONT SUSPENSION MEMBER

Removal and Installation

INFOID:000000001327544

REMOVAL

1. Set engine slinger to engine, then suspend an engine.
2. Remove tires from vehicle with power tool.
3. Remove undercover with power tool.
4. Remove front cross bar.
5. Remove mounting bolts which are at the back of transverse link (mounting part with body) with power tool, separate transverse link.
6. Remove mounting bolts which are at the front of transverse link with power tool, separate transverse link.
7. Remove steering hydraulic piping bracket from front suspension member. Refer to [PS-37](#).
8. Remove mounting bolts of steering gear with power tool, then hang steering gear on vehicle. Refer to [PS-17](#).
9. Remove stabilizer bar from front suspension member and stabilizer connecting rod lower side with power tool.
10. Remove mounting nuts between engine mounting insulator and front suspension member.
11. Remove mounting nuts between front suspension member and body with power tool.
12. Move jack down slowly to remove front suspension member from vehicle.

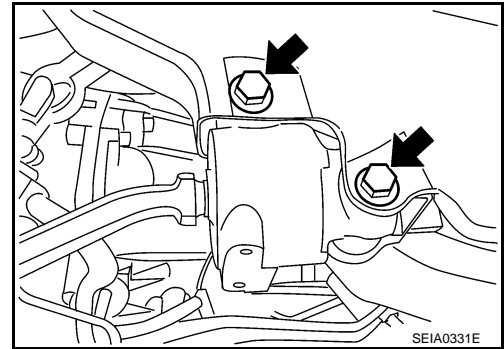

INSPECTION AFTER REMOVAL

Check front suspension member for deformation, cracks, or any other damage. Replace if necessary.

INSTALLATION

- Refer to [FSU-6. "Removal and Installation"](#) for tightening torque. Install in the reverse order of removal.

NOTE:

Refer to component parts location and do not reuse non-reusable parts.

- After removing/installing or replacing suspension components and steering components, check wheel alignment. Refer to [FSU-5. "Wheel Alignment Inspection"](#).
- After adjusting wheel alignment, adjust neutral position of steering angle sensor. Refer to [BRC-8. "Adjustment of Steering Angle Sensor Neutral Position"](#).

SERVICE DATA AND SPECIFICATIONS (SDS)

< SERVICE INFORMATION >

SERVICE DATA AND SPECIFICATIONS (SDS)

Wheel Alignment (Unladen*)

INFOID:000000001327545

Camber Degree minute (Decimal degree)	Minimum	-1°29' (-1.48°)	
	Nominal	-0°44' (-0.73°)	
	Maximum	0°01' (0.02°)	
	Left and right difference	45' (0.75°) or less	
Caster Degree minute (Decimal degree)	Minimum	3°02' (3.03°)	
	Nominal	3°47' (3.78°)	
	Maximum	4°32' (4.53°)	
	Left and right difference	45' (0.75°) or less	
Kingpin inclination Degree minute (Decimal degree)	Minimum	12°20' (12.33°)	
	Nominal	13°05' (13.08°)	
	Maximum	13°50' (13.83°)	
Total toe-in	Distance	Minimum	0.6 mm (0.024 in)
		Nominal	1.6 mm (0.063 in)
		Maximum	2.6 mm (0.102 in)
	Angle (left wheel or right wheel) Degree minute (Decimal degree)	Minimum	0°01' (0.02°)
		Nominal	0°04' (0.06°)
		Maximum	0°06' (0.10°)

*: Fuel, engine coolant and lubricant are oil full. Spare tire, jack, hand tools and mats are in designated positions.

Ball Joint

INFOID:000000001327546

Axial end play	0 mm (0 in)
Swing torque	0.5 – 4.9 N·m (0.06 – 0.49 kg-m, 5 – 43 in-lb)
Measurement on spring balance	0.5 – 4.9 N·m (0.06 – 0.49 kg-m, 5 – 43 in-lb)

Wheelarch Height (Unladen*)

INFOID:000000001327547

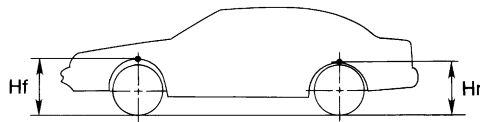

SFA818A

Destination	USA				Canada	
Engine	VQ35DE		VK45DE		VQ35DE	VK45DE
Axle	2WD		AWD		AWD	
Tire size	265/60R18	265/50R20	265/60R18	265/50R20	265/60R18	265/50R20

SERVICE DATA AND SPECIFICATIONS (SDS)

< SERVICE INFORMATION >

Front (Hf)	835 mm (32.87 in)	834 mm (32.83 in)	834 mm (32.83 in)	833 mm (32.80 in)	832 mm (32.76 in)	834 mm (32.83 in)	833 mm (32.80 in)	832 mm (32.76 in)
Rear (Hr)	822 mm (32.36 in)	821 mm (32.32 in)	829 mm (32.64 in)	827 mm (32.56 in)	825 mm (32.48 in)	827 mm (32.56 in)	826 mm (32.52 in)	823 mm (32.40 in)

*: Fuel, engine coolant and lubricant are oil full. Spare tire, jack, hand tools and mats are in designated positions.