

SECTION **CHG**
CHARGING SYSTEM

A

B

C

D

E

CONTENTS

BASIC INSPECTION	3	S TERMINAL CIRCUIT	14	F
DIAGNOSIS AND REPAIR WORKFLOW	3	Description	14	
Work Flow	3	Diagnosis Procedure	14	
SYSTEM DESCRIPTION	6	CHARGING SYSTEM	15	G
CHARGING SYSTEM	6	Wiring Diagram - CHARGING SYSTEM -	15	
System Diagram	6	SYMPTOM DIAGNOSIS	23	H
System Description	6	CHARGING SYSTEM	23	
VQ35HR	6	Symptom Table	23	I
VQ35HR : Component Parts Location	6	PRECAUTION	24	
VK50VE	7	PRECAUTIONS	24	J
VK50VE : Component Parts Location	7	Precaution for Supplemental Restraint System (SRS) "AIR BAG" and "SEAT BELT PRE-TENSIONER"	24	
Component Description	7	Precaution for Power Generation Voltage Variable Control System	24	K
POWER GENERATION VOLTAGE VARIABLE CONTROL SYSTEM	8	PREPARATION	25	L
System Diagram	8	PREPARATION	25	
System Description	8	Special Service Tools	25	
VQ35HR	8	Commercial Service Tools	25	CHG
VQ35HR : Component Parts Location	8	PERIODIC MAINTENANCE	26	
VK50VE	8	CHARGING SYSTEM PRELIMINARY INSPECTION	26	N
VK50VE : Component Parts Location	9	Inspection Procedure	26	
Component Description	9	POWER GENERATION VOLTAGE VARIABLE CONTROL SYSTEM OPERATION INSPECTION	27	O
DTC/CIRCUIT DIAGNOSIS	10	Inspection Procedure	27	
B TERMINAL CIRCUIT	10	REMOVAL AND INSTALLATION	29	P
Description	10	ALTERNATOR	29	
Diagnosis Procedure	10	VQ35HR	29	
L TERMINAL CIRCUIT (OPEN)	11			
Description	11			
Diagnosis Procedure	11			
L TERMINAL CIRCUIT (SHORT)	13			
Description	13			
Diagnosis Procedure	13			

VQ35HR : Exploded View	29
VQ35HR : Removal and Installation (2WD)	30
VQ35HR : Removal and Installation (AWD)	31
VQ35HR : Inspection	32
VK50VE	32
VK50VE : Exploded View	32
VK50VE : Removal and Installation	34
VK50VE : Inspection	34

SERVICE DATA AND SPECIFICATIONS	
(SDS)	36

SERVICE DATA AND SPECIFICATIONS	
(SDS)	36
Alternator	36

DIAGNOSIS AND REPAIR WORKFLOW

< BASIC INSPECTION >

BASIC INSPECTION

DIAGNOSIS AND REPAIR WORKFLOW

Work Flow

INFOID:000000005242953

OVERALL SEQUENCE

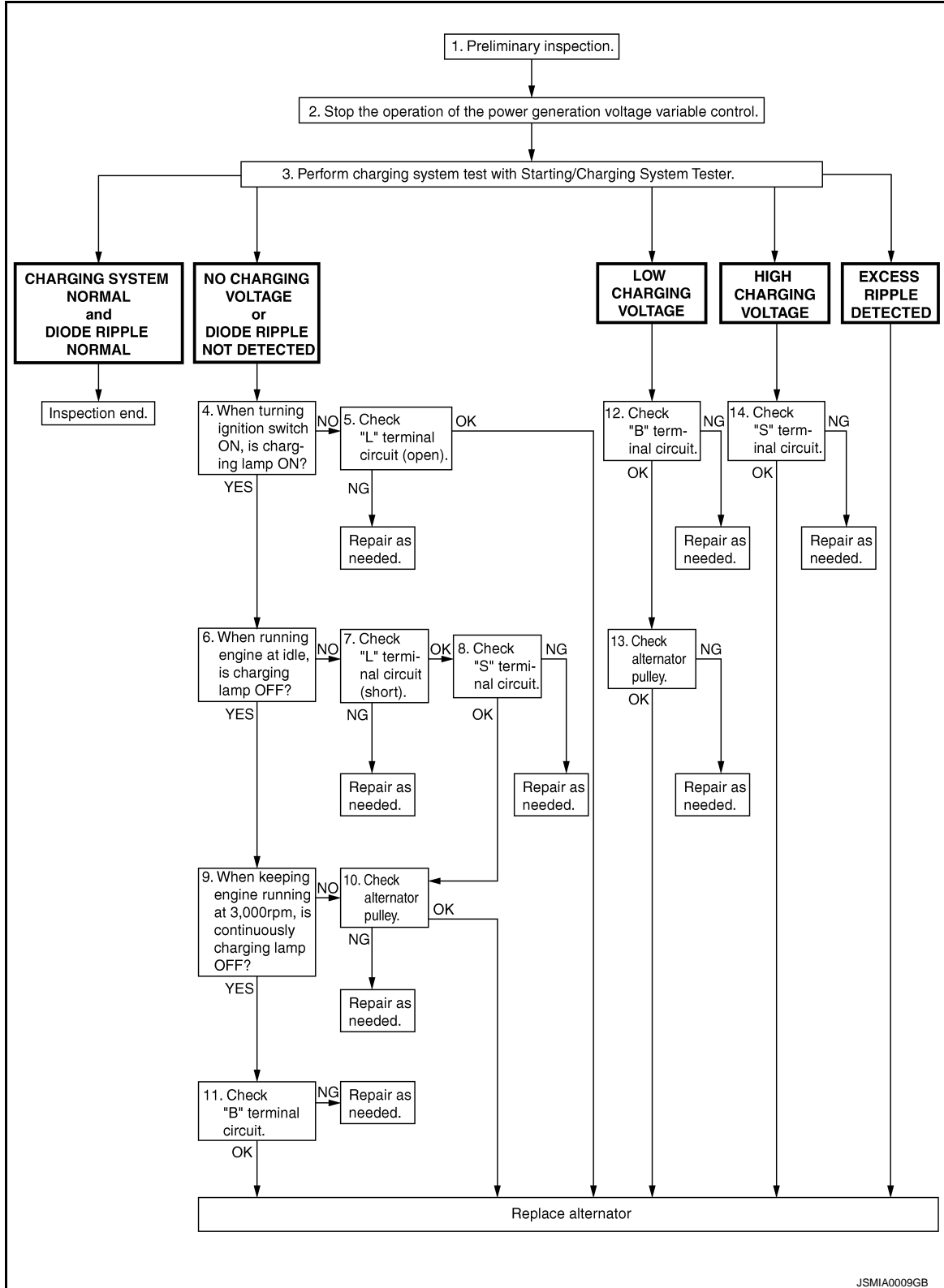

DETAILED FLOW

A
B
C
D
E
F
G
H
I
J
K
L
N
O
P

CHG

DIAGNOSIS AND REPAIR WORKFLOW

< BASIC INSPECTION >

NOTE:

To ensure a complete and thorough diagnosis, the battery, starter and alternator test segments must be done as a set from start to finish.

1. PRELIMINARY INSPECTION

Perform the preliminary inspection. Refer to [CHG-26, "Inspection Procedure"](#).

>> GO TO 2.

2. STOP POWER GENERATION VOLTAGE VARIABLE CONTROL SYSTEM

Stop the operation of the power generation voltage variable control in either of the following procedures.

- After selecting "ENGINE" of "SELECT SYSTEM" using CONSULT-III, set the DUTY value of "ALTERNATOR DUTY" to 0 % by selecting "ALTERNATOR DUTY" of "Active Test". Continue "Active Test" until the end of inspection. (When the DUTY value is 0 or 100 %, the normal power generation is performed according to the characteristic of the IC voltage regulator of the alternator.)
- Turn the ignition switch OFF, and disconnect the battery current sensor connector. [However, DTC (P1550 - P1554) of the engine might remain. After finishing the inspection, connect the battery current sensor connector and erase the self-diagnosis results history of the engine using CONSULT-III.]

>> GO TO 3.

3. DIAGNOSIS WITH STARTING/CHARGING SYSTEM TESTER

Perform the charging system test using Starting/Charging System Tester (SST: J-44373). For details and operating instructions, refer to Technical Service Bulletin.

Test result

CHARGING SYSTEM NORMAL>>Charging system is normal and will also show "DIODE RIPPLE" test result.

NO CHARGING VOLTAGE>>GO TO 4.

LOW CHARGING VOLTAGE>>GO TO 12.

HIGH CHARGING VOLTAGE>>GO TO 14.

DIODE RIPPLE NORMAL>>Diode ripple is OK and will also show "CHARGING VOLTAGE" test result.

EXCESS RIPPLE DETECTED>>Replace the alternator. Perform "DIODE RIPPLE" test again using Starting/Charging System Tester (SST: J-44373) to confirm repair.

DIODE RIPPLE NOT DETECTED>>GO TO 4.

4. INSPECTION WITH CHARGE WARNING LAMP (IGNITION SWITCH IS ON)

Turn the ignition switch ON.

Does the charge warning lamp illuminate?

YES >> GO TO 6.

NO >> GO TO 5.

5. "L" TERMINAL CIRCUIT (OPEN) INSPECTION

Check "L" terminal circuit (open). Refer to [CHG-11, "Diagnosis Procedure"](#).

Is the "L" terminal circuit normal?

YES >> Replace alternator.

NO >> Repair as needed.

6. INSPECTION WITH CHARGE WARNING LAMP (IDLING)

Start the engine and run it at idle.

Does the charge warning lamp turn OFF?

YES >> GO TO 9.

NO >> GO TO 7.

7. "L" TERMINAL CIRCUIT (SHORT) INSPECTION

Check "L" terminal circuit (short). Refer to [CHG-13, "Diagnosis Procedure"](#).

Is the "L" terminal circuit normal?

YES >> GO TO 8.

NO >> Repair as needed.

DIAGNOSIS AND REPAIR WORKFLOW

< BASIC INSPECTION >

8. "S" TERMINAL CIRCUIT INSPECTION

Check "S" terminal circuit. Refer to [CHG-14, "Diagnosis Procedure"](#).

Is the "S" terminal circuit normal?

YES >> GO TO 10.

NO >> Repair as needed.

9. INSPECTION WITH CHARGE WARNING LAMP (ENGINE AT 3,000 RPM)

Increase and maintain the engine speed at 3,000 rpm.

Does the charge warning lamp remain off?

YES >> GO TO 11.

NO >> GO TO 10.

10. INSPECTION OF ALTERNATOR PULLEY

Check alternator pulley. Refer to [CHG-32, "VQ35HR : Inspection"](#) (VQ35HR) or [CHG-34, "VK50VE : Inspection"](#) (VK50VE).

Is alternator pulley normal?

YES >> Replace alternator.

NO >> Repair as needed.

11. "B" TERMINAL CIRCUIT INSPECTION

Check "B" terminal circuit. Refer to [CHG-10, "Diagnosis Procedure"](#).

Is "B" terminal circuit normal?

YES >> Replace alternator.

NO >> Repair as needed.

12. "B" TERMINAL CIRCUIT INSPECTION

Check "B" terminal circuit. Refer to [CHG-10, "Diagnosis Procedure"](#).

Is "B" terminal circuit normal?

YES >> GO TO 13.

NO >> Repair as needed.

13. INSPECTION OF ALTERNATOR PULLEY

Check alternator pulley. Refer to [CHG-32, "VQ35HR : Inspection"](#) (VQ35HR) or [CHG-34, "VK50VE : Inspection"](#) (VK50VE).

Is alternator pulley normal?

YES >> Replace alternator.

NO >> Repair as needed.

14. "S" TERMINAL CIRCUIT INSPECTION

Check "S" terminal circuit. Refer to [CHG-14, "Diagnosis Procedure"](#).

Is the "S" terminal circuit normal?

YES >> Replace alternator.

NO >> Repair as needed.

A
B
C
D
E
F
G
H
I
J
K
L
CHG
N
O
P

CHARGING SYSTEM

< SYSTEM DESCRIPTION >

SYSTEM DESCRIPTION

CHARGING SYSTEM

System Diagram

INFOID:000000005242954

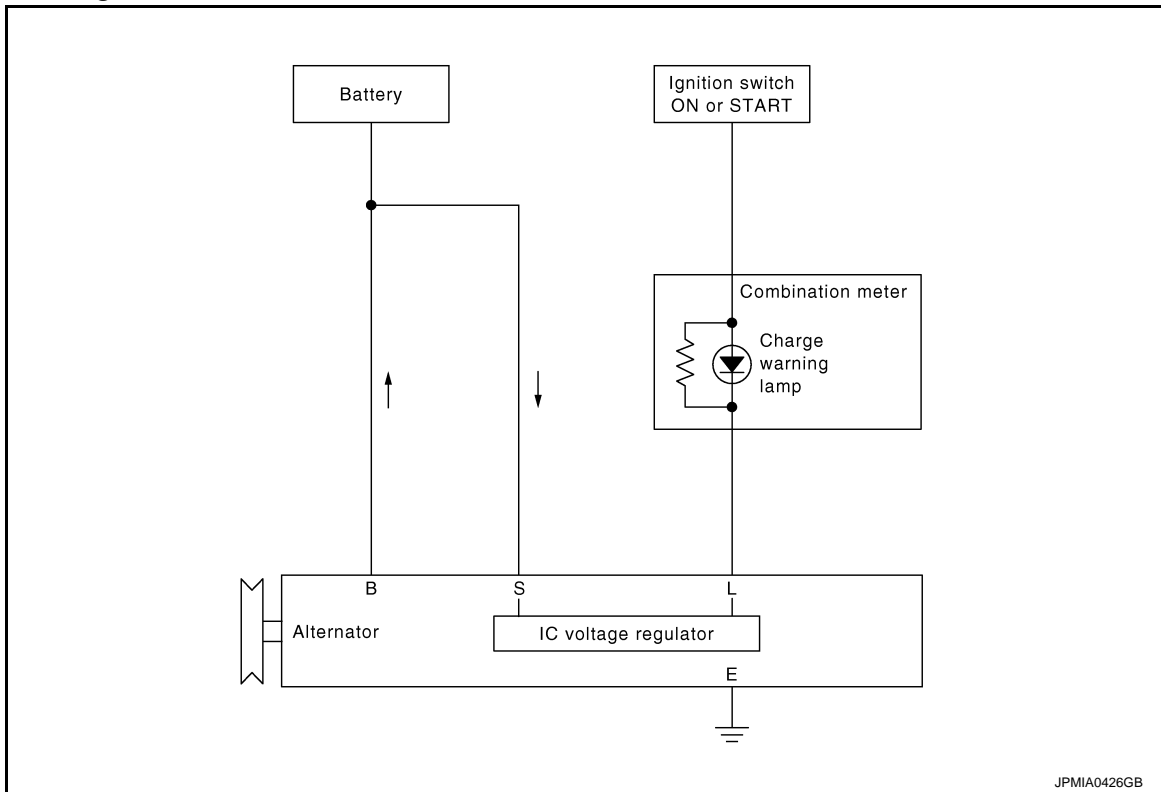

JPMIA0426GB

System Description

INFOID:000000005242955

The alternator provides DC voltage to operate the vehicle's electrical system and to keep the battery charged. The voltage output is controlled by the IC voltage regulator.

VQ35HR

VQ35HR : Component Parts Location

INFOID:000000005242956

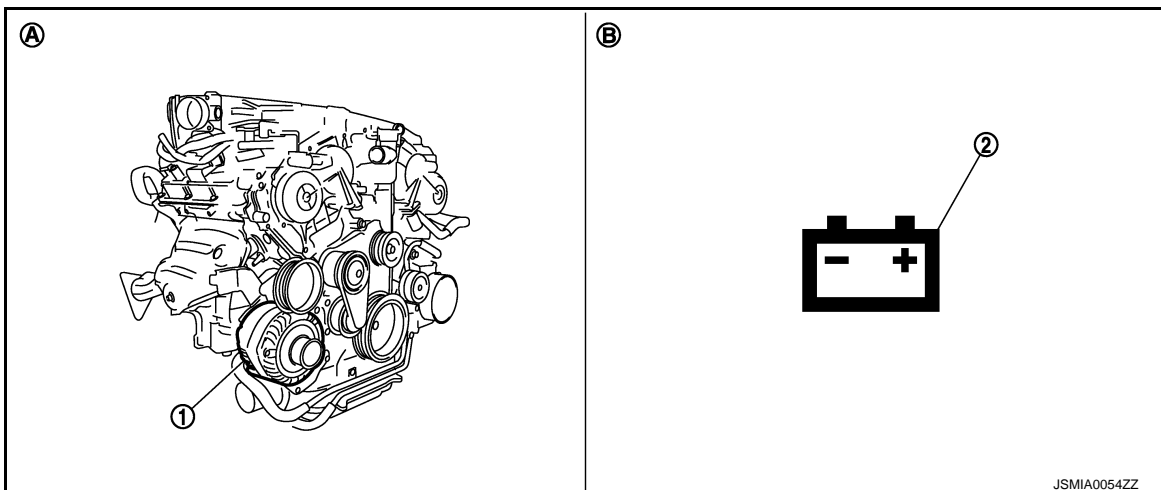

JSMIA0054ZZ

- | | |
|---------------------------------|------------------------|
| 1. Alternator | 2. Charge warning lamp |
| A. Cylinder block (bank 1) side | B. Combination meter |

CHARGING SYSTEM

< SYSTEM DESCRIPTION >

VK50VE

VK50VE : Component Parts Location

INFOID:000000005242957

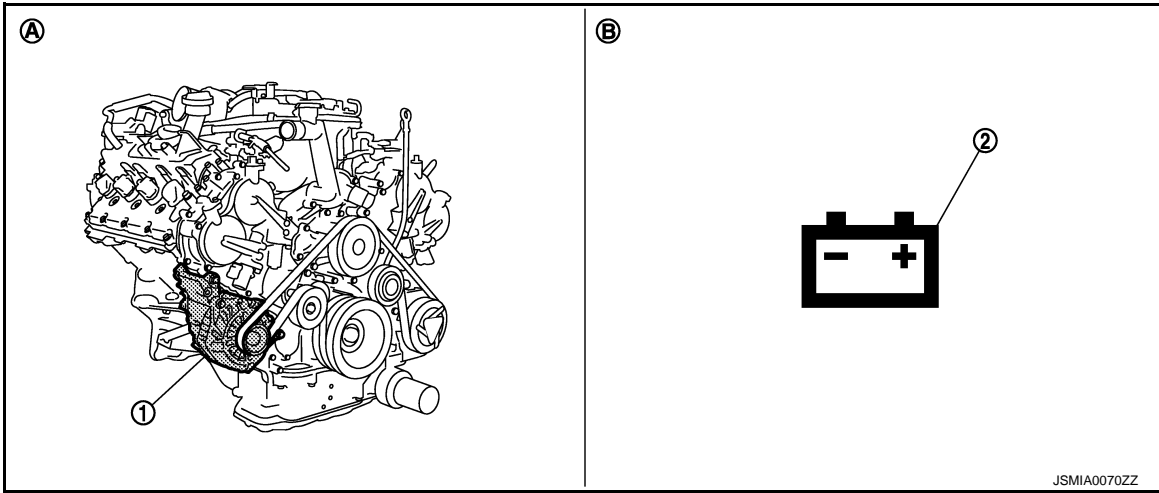

- 1. Alternator
- 2. Charge warning lamp
- A. Cylinder block (bank 1) side
- B. Combination meter

Component Description

INFOID:000000005242958

Component part	Description
Alternator	The alternator provides DC voltage to operate the vehicle electrical system and to keep the battery charged.
Combination meter (Charge warning lamp)	The IC voltage regulator warning function activates to illuminate the charge warning lamp, if any of the following symptoms occur while alternator is operating: <ul style="list-style-type: none"> • Excessive voltage is produced. • No voltage is produced.

A
B
C
D
E
F
G
H
I
J
K
L
N
O
P

CHG

POWER GENERATION VOLTAGE VARIABLE CONTROL SYSTEM

< SYSTEM DESCRIPTION >

POWER GENERATION VOLTAGE VARIABLE CONTROL SYSTEM

System Diagram

INFOID:000000005242959

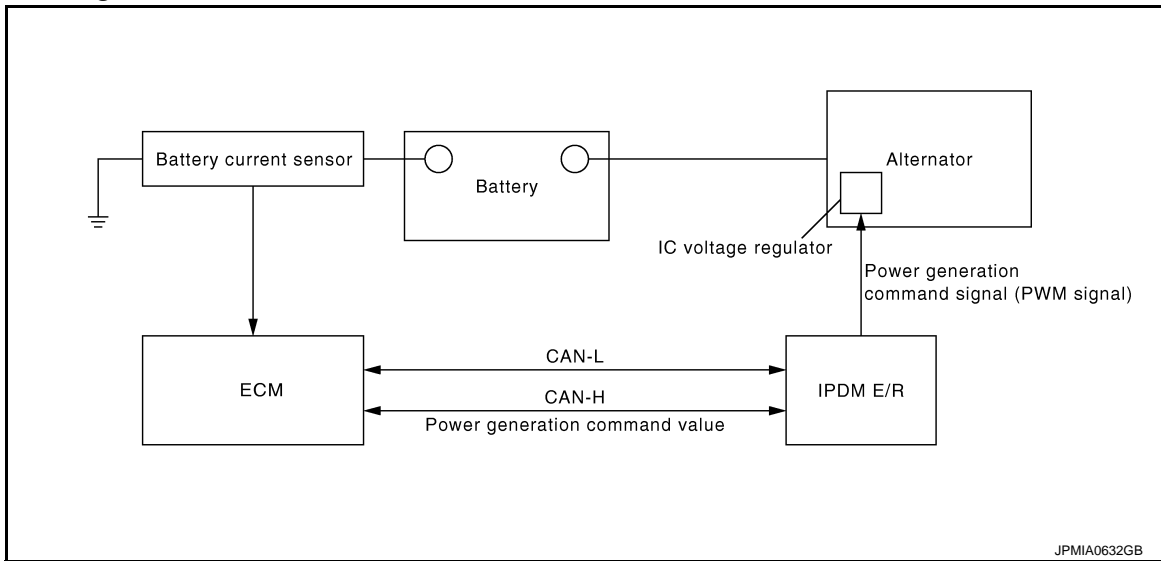

System Description

INFOID:000000005242960

By performing the power generation voltage variable control, the engine load due to the power generation of the alternator is reduced and fuel consumption is decreased.

NOTE:

When any malfunction is detected in the power generation voltage variable control system, the power generation is performed according to the characteristic of the IC voltage regulator of the alternator.

VQ35HR

VQ35HR : Component Parts Location

INFOID:000000005242961

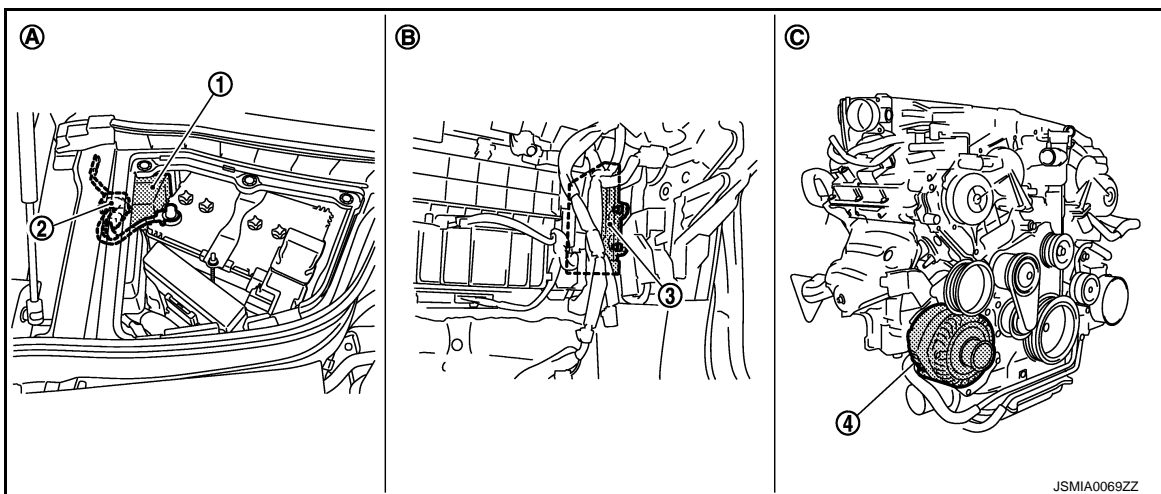

- | | | |
|--------------------------------|---------------------------|---------------------------------|
| 1. IPDM E/R | 2. Battery current sensor | 3. ECM |
| 4. Alternator | | |
| A. Engine room dash panel (RH) | B. Behind glove box | C. Cylinder block (bank 1) side |

VK50VE

POWER GENERATION VOLTAGE VARIABLE CONTROL SYSTEM

< SYSTEM DESCRIPTION >

VK50VE : Component Parts Location

INFOID:000000005242962



- | | | |
|--------------------------------|---------------------------|---------------------------------|
| 1. IPDM E/R | 2. Battery current sensor | 3. ECM |
| 4. Alternator | | |
| A. Engine room dash panel (RH) | B. Behind glove box | C. Cylinder block (bank 1) side |

Component Description

INFOID:000000005242963

Component part	Description
Battery current sensor	Battery current sensor is installed to the battery cable at the negative terminal, and it detects the charging/discharging current of the battery and sends the voltage signal to ECM according to the current value.
ECM	Battery current sensor detects the charging/discharging current of the battery. ECM judges the battery condition based on this signal. ECM judges whether to perform the power generation voltage variable control according to the battery condition. When performing the power generation voltage variable control, ECM calculates the target power generation voltage according to the battery condition and sends the calculated value as the power generation command value to IPDM E/R.
IPDM E/R	IPDM E/R converts the received power generation command value into the power generation command signal (PWM signal) and sends it to the IC voltage regulator.
Alternator (IC voltage regulator)	IC voltage regulator controls the power generation voltage by the target power generation voltage based on the received power generation command signal. When there is no power generation command signal, the alternator performs the normal power generation according to the characteristic of the IC voltage regulator.

A
B
C
D
E
F
G
H
I
J
K
L
CHG
N
O
P

B TERMINAL CIRCUIT

< DTC/CIRCUIT DIAGNOSIS >

DTC/CIRCUIT DIAGNOSIS

B TERMINAL CIRCUIT

Description

INFOID:000000005242964

"B" terminal circuit supplies power to charge the battery and to operate the vehicle's electrical system.

Diagnosis Procedure

INFOID:000000005242965

1. CHECK "B" TERMINAL CONNECTION

1. Turn ignition switch OFF.
2. Check if "B" terminal is clean and tight.

Is the inspection result normal?

YES >> GO TO 2.

NO >> Repair "B" terminal connection. Confirm repair by performing complete Starting/Charging system test. Refer to Technical Service Bulletin.

2. CHECK "B" TERMINAL CIRCUIT

Check voltage between alternator "B" terminal and ground.

Terminals			Voltage (Approx.)
(+)	(-)		
Alternator "B" terminal	Terminal		Battery voltage
E203	1	Ground	

Is the inspection result normal?

YES >> GO TO 3.

NO >> Check harness for open between alternator and fusible link.

3. CHECK "B" TERMINAL CONNECTION (VOLTAGE DROP TEST)

1. Start engine, then engine running at idle and warm.
2. Check voltage between battery positive terminal and alternator "B" terminal.

Terminals			Voltage (Approx.)
(+)	(-)		
Battery positive terminal	Alternator "B" terminal	Terminal	Less than 0.2 V
	E203	1	

Is the inspection result normal?

YES >> "B" terminal circuit is normal. Refer to [CHG-3, "Work Flow"](#).

NO >> Check harness between battery and alternator for poor continuity.

L TERMINAL CIRCUIT (OPEN)

< DTC/CIRCUIT DIAGNOSIS >

L TERMINAL CIRCUIT (OPEN)

Description

INFOID:000000005242966

The "L" terminal circuit controls the charge warning lamp. The charge warning lamp illuminates when the ignition switch is set to ON or START. When the alternator is providing sufficient voltage with the engine running, the charge warning lamp will go off. If the charge warning lamp illuminates with the engine running, a malfunction is indicated.

Diagnosis Procedure

INFOID:000000005242967

1. CHECK "L" TERMINAL CONNECTION

1. Turn ignition switch OFF.
2. Check if "L" terminal is clean and tight.

Is the inspection result normal?

YES >> GO TO 2.

NO >> Repair "L" terminal connection. Confirm repair by performing complete Starting/Charging system test. Refer to Technical Service Bulletin.

2. CHECK "L" TERMINAL CIRCUIT (OPEN)

1. Disconnect alternator connector.
2. Apply ground to alternator harness connector terminal.
3. Check condition of the charge warning lamp with the ignition switch in the ON position.

Alternator harness connector	Terminal	Ground	Condition	
			Ignition switch position	Charge warning lamp
F36	2		ON	Illuminate

Does it illuminate?

YES >> "L" terminal circuit is normal. Refer to [CHG-3. "Work Flow"](#).

NO >> GO TO 3.

3. CHECK HARNESS CONTINUITY (OPEN CIRCUIT)

1. Disconnect the battery cable from the negative terminal.
2. Disconnect the combination meter connector.
3. Check continuity between alternator harness connector and combination meter harness connector.

Alternator harness connector		Combination meter harness connector		Continuity
Connector No.	Terminal No.	Connector No.	Terminal No.	
F36	2	M53	6	Existed

Is the inspection result normal?

YES >> GO TO 4.

NO >> Repair the harness or connector.

4. CHECK HARNESS CONTINUITY (OPEN CIRCUIT)

Check continuity between combination meter harness connector and fuse block.

Combination meter harness connector		Fuse block		Continuity
Connector No.	Terminal No.	Connector No.	Terminal No.	
M53	21	M3	12C	Existed

Is the inspection result normal?

YES >> GO TO 5.

NO >> Repair the harness.

5. CHECK POWER SUPPLY CIRCUIT

1. Connect the battery cable to the negative terminal.

A
B
C
D
E
F
G
H
I
J
K
L

CHG

N
O
P

L TERMINAL CIRCUIT (OPEN)

< DTC/CIRCUIT DIAGNOSIS >

2. Check voltage between combination meter harness connector and ground.

Terminals		(-)	Condition	Voltage (Approx.)
(+)	Terminal			
Combination meter harness connector				
M53	21	Ground	When the ignition switch is in ON position	Battery voltage

Is the inspection result normal?

YES >> Replace combination meter.

NO >> Inspect the power supply circuit. Refer to [PG-81, "Wiring Diagram - IGNITION POWER SUPPLY -](#)

["](#)

L TERMINAL CIRCUIT (SHORT)

< DTC/CIRCUIT DIAGNOSIS >

L TERMINAL CIRCUIT (SHORT)

Description

INFOID:000000005242968

The "L" terminal circuit controls the charge warning lamp. The charge warning lamp illuminates when the ignition switch is set to ON or START. When the alternator is providing sufficient voltage with the engine running, the charge warning lamp will go off. If the charge warning lamp illuminates with the engine running, a malfunction is indicated.

Diagnosis Procedure

INFOID:000000005242969

1. CHECK "L" TERMINAL CIRCUIT (SHORT)

1. Turn ignition switch OFF.
2. Disconnect alternator connector.
3. Turn ignition switch ON.

Does charge warning lamp illuminate?

- YES >> GO TO 2.
NO >> Refer to [CHG-3. "Work Flow"](#).

2. CHECK HARNESS CONTINUITY (SHORT CIRCUIT)

1. Turn the ignition switch OFF.
2. Disconnect the battery cable from the negative terminal.
3. Disconnect combination meter connector.
4. Check continuity between combination meter harness connector and ground.

Combination meter harness connector		Ground	Continuity
Connector No.	Terminal No.		
M53	6		Not existed

Is the inspection result normal?

- YES >> Replace combination meter.
NO >> Repair the harness.

A
B
C
D
E
F
G
H
I
J
K
L

CHG

N
O
P

S TERMINAL CIRCUIT

< DTC/CIRCUIT DIAGNOSIS >

S TERMINAL CIRCUIT

Description

INFOID:000000005242970

The output voltage of the alternator is controlled by the IC voltage regulator at the "S" terminal detecting the input voltage.

The "S" terminal circuit detects the battery voltage to adjust the alternator output voltage with the IC voltage regulator.

Diagnosis Procedure

INFOID:000000005242971

1. CHECK "S" TERMINAL CONNECTION

1. Turn ignition switch OFF.
2. Check if "S" terminal is clean and tight.

Is the inspection result normal?

YES >> GO TO 2.

NO >> Repair "S" terminal connection. Confirm repair by performing complete Starting/Charging system test. Refer to Technical Service Bulletin.

2. CHECK "S" TERMINAL CIRCUIT

Check voltage between alternator harness connector and ground.

Terminals		Voltage (Approx.)
(+)	(-)	
Alternator harness connector	Terminal	Battery voltage
F36	3	
	Ground	

Is the inspection result normal?

YES >> Refer to [CHG-3, "Work Flow"](#).

NO >> Check harness for open between alternator and fuse.

CHARGING SYSTEM

< DTC/CIRCUIT DIAGNOSIS >

CHARGING SYSTEM

Wiring Diagram - CHARGING SYSTEM -

INFOID:000000005242972

CHARGING SYSTEM

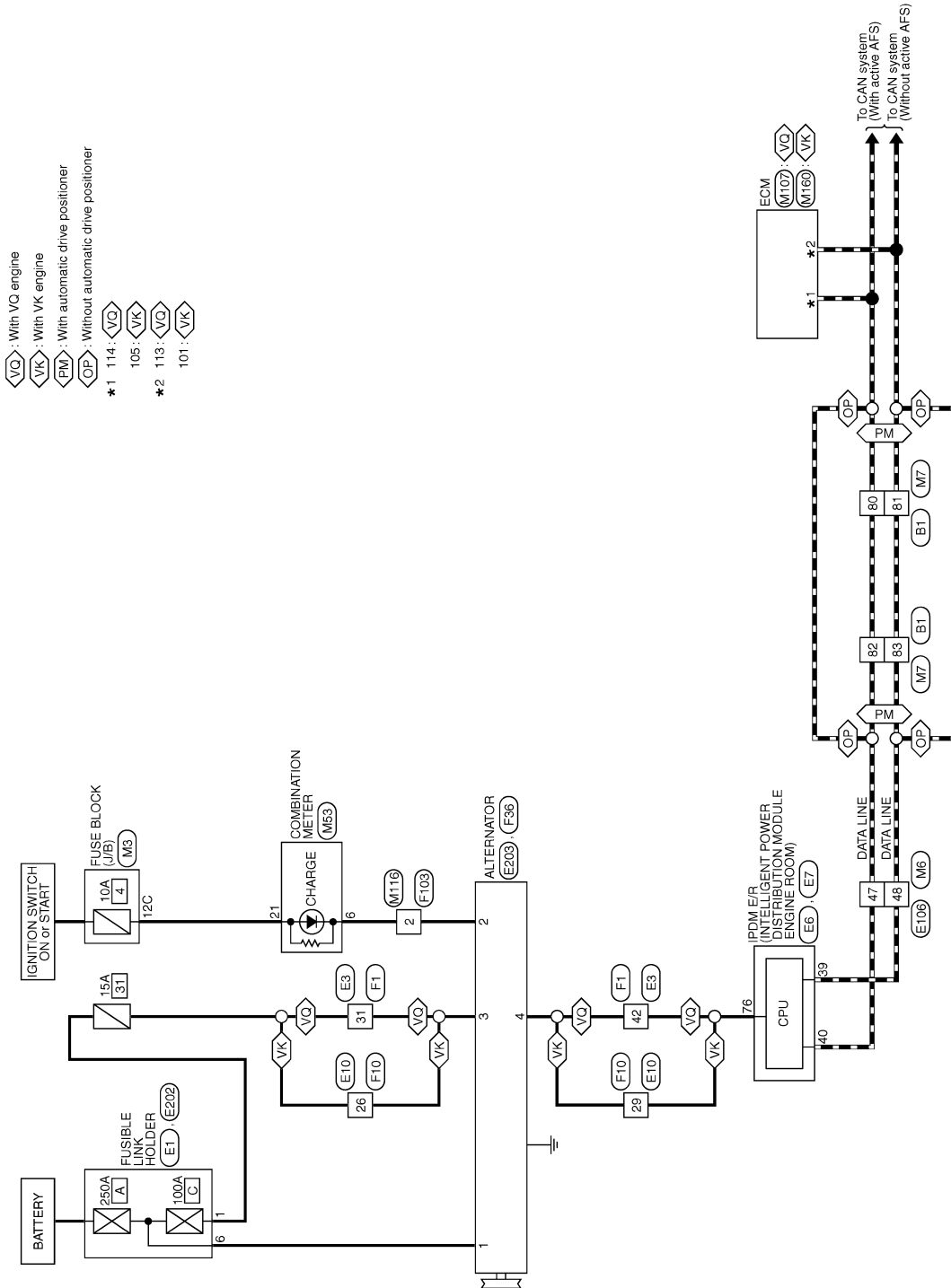

- ◊ VQ : With VQ engine
- ◊ VK : With VK engine
- ◊ PM : With automatic drive positioner
- ◊ OP : Without automatic drive positioner
- *1 114: ◊ VQ
- 105: ◊ VK
- *2 113: ◊ VQ
- 101: ◊ VK

2009/07/29

JCMWA4999GB

CHG

CHARGING SYSTEM

< DTC/CIRCUIT DIAGNOSIS >

CHARGING SYSTEM

Connector No.	B1
Connector Name	WIRE TO WIRE
Connector Type	TH08PW-CS16-TM4

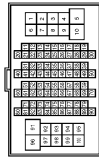

Terminal No.	Color of Wire	Signal Name [Specification]
1	G	
2	L	
3	W	
5	G	
6	G	
7	P	
8	O	
9	W	
10	SB	
11	SB	
12	B	
13	G	
14	R	
15	W	
16	SHIELD	
17	L	
18	P	
19	G	
20	Y	
21	W	
23	V	
24	P	
25	BR	
26	GR	
27	O	
28	W	
29	SHIELD	
38	B	
39	B	
40	LG	
41	G	
42	GR	
43	SB	
44	V	
45	GR	
50	B	
51	V	
52	SB	

53	SHIELD	
54	BR	
55	Y	
56	SHIELD	
57	P	
58	L	
59	SHIELD	
60	L	
61	P	
62	GR	
63	G	
64	O	
65	W	
66	V	
67	LG	
68	Y	
69	G	
70	GR	
71	G	
72	B	
73	W	
74	V	
75	O	
76	LG	
77	L	
78	GR	
79	W	
80	V	
81	P	
82	L	
83	P	
84	SB	
85	R	
86	Y	
87	B	
88	G	
89	BR	
90	W	
91	R	
92	O	
93	BR	
94	V	
95	Y	
96	O	
97	W	
98	GR	
99	W	

Connector No.	E1
Connector Name	FUSIBLE LINK HOLDER
Connector Type	L02FBR-MC



Terminal No.	Color of Wire	Signal Name [Specification]
1	R	
2	W	

Connector No.	E3
Connector Name	WIRE TO WIRE
Connector Type	SA438MB-RS10-SJ22

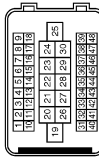

Terminal No.	Color of Wire	Signal Name [Specification]
19	W	
20	GR	
21	G	
22	LG	
23	W	
24	BR	
25	BR	
26	BR	
27	R	
28	R	
29	L	
30	V	
31	LG	
32	L	
33	P	
34	G	
35	Y	
40	O	
41	W	
42	V	
43	W	

Connector No.	E6
Connector Name	ENGINE INTELLIGENT POWER DISTRIBUTION MODULE ENGINE ROOM
Connector Type	TH08PW-NH



Terminal No.	Color of Wire	Signal Name [Specification]
39	P	
40	L	
41	B	
42	Y	
43	SB	
44	W	
45	G	
46	BR	

JCMWA5000GB

CHARGING SYSTEM

< DTC/CIRCUIT DIAGNOSIS >

A
B
C
D
E
F
G
H
I
J
K
L
N
O
P

CHARGING SYSTEM

Connector No.	E7
Connector Name	ENGINE FUEL INJECTOR POWER DISTRIBUTION MODULE ENGINE FICM
Connector Type	TH20FW-GS12-M4

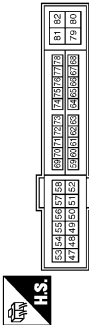

Terminal No.	Color of Wire	Signal Name [Specification]
48	L	-
49	W	- [With VK engine]
49	SB	- [With VQ engine]
51	G	-
52	W	-
53	W	-
54	R	-
55	BR	-
56	O	- [With VK engine]
56	V	- [With VQ engine]
57	LG	-
58	Y	-
58	W	-
59	O	-
74	G	-
74	Y	-
76	P	- [With VK engine]
76	V	- [With VQ engine]
77	B	- [With VK engine]
77	L	- [With VQ engine]
80	W	-

Connector No.	E10
Connector Name	WIRE TO WIRE
Connector Type	SAA36MF-RSS-SHZ8



Terminal No.	Color of Wire	Signal Name [Specification]
1	I	SHIELD
2	-	-

2	L	-
3	G	-
4	BR	-
5	G	-
6	BR	-
7	W	-
8	SHIELD	-
9	W	-
10	W	-
11	W	-
12	W	-
13	R	-
14	LG	-
15	O	-
16	W	-
17	P	-
18	W	-
19	W	-
20	BR	-
21	SB	-
22	W	-
23	V	-
24	Y	-
26	LG	-
27	G	-
28	GR	-
29	Y	-
30	W	-
31	G	-
32	L	-
33	O	-
35	R	-
36	SHIELD	-
37	Y	-
38	SHIELD	-
39	W	-
40	SHIELD	-
41	Y	-
42	SHIELD	-
43	W	-
44	G	-
45	L	-
46	G	-
47	B	-
48	R	-
49	L	-
50	G	-
51	B	-
52	R	-

JCMWA5001GB

CHG

CHARGING SYSTEM

< DTC/CIRCUIT DIAGNOSIS >

CHARGING SYSTEM

Connector No.	E106
Connector Name	WIRE TO WIRE
Connector Type	THBDFW-CS16-TM4



Terminal No.	Color of Wire	Signal Name [Specification]
1	G	-
2	O	-
3	SB	-
4	LG	-
5	Y	-
6	W	-
7	G	-
8	V	-
9	R	-
10	BR	-
11	B	-
12	G	-
13	R	-
14	W	-
15	SHIELD	-
16	SB	-
17	L	-
18	P	-
19	G	-
20	W	- [With ICC]
21	Y	- [Without ICC]
22	R	- [With ICC]
23	V	- [Without ICC]
24	G	-
24	L	- [With ICC]
24	P	- [Without ICC]
25	Y	- [With ICC]
25	L	- [Without ICC]
26	SHIELD	-
28	G	-
29	LG	-
30	O	-
31	BR	-
32	W	-
33	Y	-
34	O	-
35	SB	-

36	P	-
37	Y	-
38	GR	-
39	LG	-
41	LG	-
42	V	-
43	R	-
44	G	-
45	GR	-
46	W	-
47	L	-
48	P	-
49	SB	-
50	BR	-
51	B	-
52	Y	-
53	O	-
54	R	-
55	SB	-
56	P	-
59	P	-
60	SB	-
61	V	-
62	P	-
63	LG	-
64	L	-
65	O	-
66	L	-
68	L	-
70	SHIELD	-
71	G	-
72	G	-
73	R	-
74	BR	-
76	L	-
77	W	-
78	Y	-
80	SB	-
81	L	-
82	W	-
83	LG	-
84	GR	-
85	G	-
86	P	-
87	W	-
88	O	-
89	LG	-
90	BR	-
91	GR	-
92	BR	-
93	SB	-
94	W	-

Terminal No.	95	Y	-	-
	96	W	-	-
	100	Y	-	-

Connector No.	E202
Connector Name	FUSIBLE LINK HOLDER
Connector Type	-



Terminal No.	6	B/Y	-	-
--------------	---	-----	---	---

Connector No.	E203
Connector Name	ALTERNATOR
Connector Type	-



Terminal No.	1	B/Y	B	-
--------------	---	-----	---	---

Connector No.	F1
Connector Name	WIRE TO WIRE
Connector Type	SAA38FB-RS10-SJ22

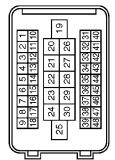

Terminal No.	Color of Wire	Signal Name [Specification]
19	W	-
20	GR	-
21	P	-
22	G	-
23	W	-
23	P	-
26	BR	-
27	R	-
28	R	-
29	L	-
30	Y	-
31	V	-
32	LG	-
33	GR	-
34	G	-
35	Y	-
40	O	-
41	SB	-
42	P	-
43	BR	-

CHARGING SYSTEM

< DTC/CIRCUIT DIAGNOSIS >

CHARGING SYSTEM

Connector No.	F10
Connector Name	WIRE TO WIRE
Connector Type	SA-A3FB-RS-SH23

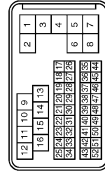

Terminal No.	Color of Wire	Signal Name [Specification]
1	SHIELD	-
2	Y	-
3	G	-
4	BR	-
5	B	-
6	W	-
7	R	-
8	SHIELD	-
9	W	-
10	G	-
11	Y	-
12	V	-
13	P	-
14	L	-
15	O	-
16	R	-
17	GR	-
18	G	-
19	O	-
20	R	-
21	V	-
22	B	-
23	LG	-
24	Y	-
26	O	-
27	SB	-
28	LG	-
29	P	-
30	GR	-
31	BR	-
32	G	-
33	L	-
35	P	-
36	SHIELD	-
37	Y	-
38	SHIELD	-
39	W	-
40	SHIELD	-

41	Y	-
42	SHIELD	-
43	W	-
44	LG	-
45	L	-
46	G	-
47	B	-
48	R	-
49	L	-
50	G	-
51	B	-
52	R	-

Connector No.	F96
Connector Name	ALTERNATOR
Connector Type	HS03FB



Terminal No.	Color of Wire	Signal Name [Specification]
2	G	L
3	O	S [With-VK engine]
3	V	S [With-VG engine]
4	P	G

Connector No.	F103
Connector Name	WIRE TO WIRE
Connector Type	TK38FW-NS10



Terminal No.	Color of Wire	Signal Name [Specification]
1	SHIELD	-
2	G	-
3	W	-
4	GR	- [With-VK engine]

4	R	- [With-V2 engine]
5	R	- [With-VK engine]
6	B	- [With-VG engine]
6	SHIELD	-
7	B	-
8	W	-
9	Y	- [With-VK engine]
9	L	- [With-V2 engine]
10	GR	- [With-VK engine]
10	GR	- [With-V2 engine]
17	GR	-
18	R	-
19	O	-
20	Y	-
26	BR	-
27	L	-
28	B	-
29	LG	-
31	R	-
34	LG	-
35	BR	-
36	W	-
37	Y	-
38	Y	-
43	P	-
44	L	-
45	L	-
46	Y	-

Connector No.	M3
Connector Name	FLISE BLOCK (J/B)
Connector Type	NS12FW-CS



Terminal No.	Color of Wire	Signal Name [Specification]
6C	P	-
7C	B	-
8C	O	-
10C	L	-
11C	LG	-
12C	R	-

JCMWA5003GB

A
B
C
D
E
F
G
H
I
J
K
L
N
O
P

CHG

CHARGING SYSTEM

< DTC/CIRCUIT DIAGNOSIS >

CHARGING SYSTEM

Connector No.	M16
Connector Name	WIRE TO WIRE
Connector Type	TH80MW-CS16-TM4



94	L	-
95	G	-
96	W	-
100	Y	-

35	L	-
36	P	-
37	G	-
38	R	-
39	G	-
41	U	-
42	W	-
43	R	-
44	LG	-
45	GR	-
46	W	-
47	L	-
48	P	-
49	O	-
50	LG	-
51	SB	-
52	Y	-
53	O	-
54	BR	-
55	SB	-
56	P	-
59	SB	-
60	SB	-
61	V	-
62	P	-
63	R	-
64	L	-
65	O	-
66	L	-
68	V	-
70	SHIELD	-
71	O	-
72	GR	-
73	W	-
74	SB	-
76	V	-
77	V	-
78	Y	-
80	O	-
81	L	-
82	W	-
83	Y	-
84	L	-
85	P	-
86	BR	-
87	P	-
88	V	-
89	G	-
90	P	-
91	R	-
92	R	-
93	GR	-

Terminal No.	Color of Wire	Signal Name (Specification)
1	G	-
2	O	-
3	SB	-
4	LG	-
5	GR	-
6	W	-
7	G	-
8	W	-
9	P	-
10	BR	-
11	B	-
12	G	-
13	R	-
14	W	-
15	SHIELD	-
16	BR	-
17	L	-
18	P	-
19	G	-
20	W	- [With ICC]
20	GR	- [Without ICC]
21	BR	- [With ICC]
21	R	- [Without ICC]
22	R	- [With ICC]
22	L	- [Without ICC]
23	G	-
24	L	- [With ICC]
24	P	- [Without ICC]
25	Y	- [With ICC]
25	W	- [Without ICC]
26	SHIELD	-
28	GR	-
29	V	-
30	O	-
31	BR	-
32	W	-
33	Y	-
34	L	-

JCMWA5004GB

CHARGING SYSTEM

< DTC/CIRCUIT DIAGNOSIS >

CHARGING SYSTEM

Connector No.	M7
Connector Name	WIRE TO WIRE
Connector Type	TH80MW-CS16-TM4

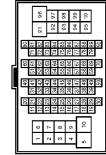

Terminal No.	Color of Wire	Signal Name [Specification]
1	G	-
2	B	-
3	W	-
5	G	-
6	P	-
7	V	-
8	O	-
9	W	-
10	W	-
11	O	-
12	B	-
13	G	-
14	R	-
15	W	-
16	SHIELD	-
17	L	-
18	P	-
19	G	-
20	R	-
21	LG	-
23	V	-
24	P	-
25	BR	-
26	GR	-
27	O	-
28	W	-
29	SHIELD	-
38	B	-
39	B	-
40	LG	-
41	G	-
42	Y	-
43	SB	-
44	W	-
45	B	-
50	B	-
51	V	-
52	LG	-

Connector No.	IM3
Connector Name	COMBINATION METER
Connector Type	TH40FW-NH

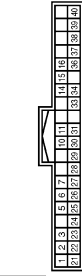

Terminal No.	Color of Wire	Signal Name [Specification]
1	O	BATTERY POWER SUPPLY
2	LG	COMMUNICATION SIGNAL (METER->AMP.)
3	GR	COMMUNICATION SIGNAL (AMP->METER)
5	B	GROUND
6	W	ALTERNATOR SIGNAL
7	P	AIR BAG SIGNAL
10	G	SECURITY INDICATOR SIGNAL
15	B	GROUND
16	B	METER CONTROL SWITCH GROUND
21	R	IGNITION POWER SUPPLY
22	B	GROUND
24	BR	COMMUNICATION SIGNAL (LCD->AMP.)
25	Y	COMMUNICATION SIGNAL (AMP->LCD)
26	R	VEHICLE SPEED SIGNAL (G PULSE)
27	V	PARKING BRAKE SWITCH SIGNAL
28	W	BRAKE FLUID LEVEL SWITCH SIGNAL
29	SB	SEAT BELT BUCKLE SW (DRIVER SIDE)
30	G	PASSENGER SEAT BELT WARNING SIGNAL
31	L	WASHER LEVEL SWITCH SIGNAL
34	O	ILL CON OUT
36	LG	SELECT SWITCH SIGNAL
37	SB	ENTER SWITCH SIGNAL
38	L	TRIP A/B RESET SWITCH SIGNAL
39	P	ILLUMINATION CONTROL SWITCH SIGNAL (-)
40	O	ILLUMINATION CONTROL SWITCH SIGNAL (+)

Connector No.	M107
Connector Name	ECM
Connector Type	RM24FCY-RZ8-R-LH-Z

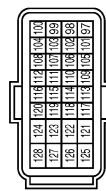

Terminal No.	Color of Wire	Signal Name [Specification]
97	R	APSI
98	Y	APSZ [With ICC]
98	P	APSZ [Without ICC]
99	G	AVCC-APSI [With ICC]
99	L	AVCC-APSI [Without ICC]
100	W	GND-A(APSI)
101	SB	ASCDSW
102	LG	FTPRS
103	L	AVCC-APSZ [With ICC]
103	G	AVCC-APSZ [Without ICC]
104	BR	GND-A(APSZ) [With ICC]
104	GR	GND-A(APSZ) [Without ICC]
105	L	PDPRESS
106	W	IF
107	BR	AVCC-FTPRS
108	V	GDA ASCD
109	G	NEUT-H
110	R	TACHO
111	O	AVCC-PDPRESS
112	V	GND-A
113	P	VEHCAN-L1
114	L	VEHCAN-H1
116	W	GND-A-PDPRES
117	GR	KLINE
121	LG	CDCV
122	P	BRAKE
123	B	GND
124	B	GND
125	GR	VBR
126	BR	BNC SW
127	B	GND
128	B	GND

53	SHIELD	-
54	BR	-
55	Y	-
56	SHIELD	-
57	P	-
58	L	-
59	SHIELD	-
60	L	-
61	BR	-
62	R	-
63	Y	-
64	L	-
65	W	-
66	V	-
67	LG	-
68	Y	-
69	G	-
70	V	-
71	W	-
72	B	-
73	W	-
74	LG	-
75	P	-
76	LG	-
77	SB	-
78	GR	-
79	R	-
80	L	-
81	P	-
82	L	-
83	P	-
84	SB	-
85	W	-
86	Y	-
87	B	-
88	G	-
89	O	-
90	W	-
91	R	-
92	O	-
93	BR	-
94	V	-
95	Y	-
96	O	-
97	W	-
98	R	-
99	G	-
99	O	-

- [With VK engine]
- [With VG engine]

JCMWA5005GB

A
B
C
D
E
F
G
H
I
J
K
L
M
N
O
P

CHG

CHARGING SYSTEM

< DTC/CIRCUIT DIAGNOSIS >

CHARGING SYSTEM

Connector No.	M116
Connector Name	WIRE TO WIRE
Connector Type	TK38AW-NS10

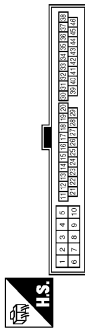

Connector No.	M160
Connector Name	ECM
Connector Type	RH24FY-R28-R-LH-Z

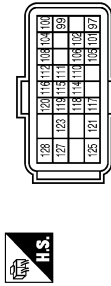

Terminal No.	Color of Wire	Signal Name [Specification]
1	B	-
2	W	-
3	L	-
4	B	- [With VK engine]
4	R	- [With VO engine]
5	R	- [With VK engine]
5	B	- [With VO engine]
6	B	-
7	B	-
9	L	- [With VK engine]
9	R	- [With VO engine]
10	R	-
17	LG	-
18	R	-
18	O	-
20	Y	-
26	V	-
27	L	-
28	B	-
29	LG	-
31	W	-
34	LG	-
35	BR	-
36	W	-
37	Y	-
38	O	-
43	P	-
44	L	-
45	G	-
46	Y	-

Terminal No.	Color of Wire	Signal Name [Specification]
97	R	TACHO
99	L	AVCC2-APSZ [With ICC]
99	G	AVCC2-APSZ [Without ICC]
100	G	AVCC-APSI [With ICC]
100	L	AVCC-APSI [Without ICC]
101	P	VEHCAN-L
102	SB	ASCDSW
104	R	APSI
105	L	VEHCAN-H
106	L	IGNSW
108	Y	APSZ [With ICC]
108	P	APSZ [Without ICC]
110	P	BRAKE
111	V	GND-ASCDSW
112	LG	FPORCK
114	GR	K-LINE
115	BR	GND-APSZ [With ICC]
115	GR	GND-APSZ [Without ICC]
116	G	NEUT-H
117	BR	BNC5W
118	R	BATT
119	W	GND-APSI
120	W	TF
121	GR	VBR
123	B	GND
125	R	FFCM
127	LG	GDCV
128	B	GND

JCMWA5006GB

CHARGING SYSTEM

< SYMPTOM DIAGNOSIS >

SYMPTOM DIAGNOSIS

CHARGING SYSTEM

Symptom Table

INFOID:000000005242973

Symptom	Reference
Discharged battery	Refer to CHG-3, "Work Flow" .
The charge warning lamp does not illuminate when the ignition switch is set to ON.	
The charge warning lamp does not turn OFF after the engine starts.	
The charging warning lamp turns ON when increasing the engine speed.	

A
B
C
D
E
F
G
H
I
J
K
L
N
O
P

CHG

PRECAUTIONS

< PRECAUTION >

PRECAUTION

PRECAUTIONS

Precaution for Supplemental Restraint System (SRS) "AIR BAG" and "SEAT BELT PRE-TENSIONER"

INFOID:000000005242974

The Supplemental Restraint System such as "AIR BAG" and "SEAT BELT PRE-TENSIONER", used along with a front seat belt, helps to reduce the risk or severity of injury to the driver and front passenger for certain types of collision. This system includes seat belt switch inputs and dual stage front air bag modules. The SRS system uses the seat belt switches to determine the front air bag deployment, and may only deploy one front air bag, depending on the severity of a collision and whether the front occupants are belted or unbelted. Information necessary to service the system safely is included in the "SRS AIR BAG" and "SEAT BELT" of this Service Manual.

WARNING:

- To avoid rendering the SRS inoperative, which could increase the risk of personal injury or death in the event of a collision which would result in air bag inflation, all maintenance must be performed by an authorized NISSAN/INFINITI dealer.
- Improper maintenance, including incorrect removal and installation of the SRS, can lead to personal injury caused by unintentional activation of the system. For removal of Spiral Cable and Air Bag Module, see the "SRS AIR BAG".
- Do not use electrical test equipment on any circuit related to the SRS unless instructed to in this Service Manual. SRS wiring harnesses can be identified by yellow and/or orange harnesses or harness connectors.

PRECAUTIONS WHEN USING POWER TOOLS (AIR OR ELECTRIC) AND HAMMERS

WARNING:

- When working near the Air Bag Diagnosis Sensor Unit or other Air Bag System sensors with the ignition ON or engine running, DO NOT use air or electric power tools or strike near the sensor(s) with a hammer. Heavy vibration could activate the sensor(s) and deploy the air bag(s), possibly causing serious injury.
- When using air or electric power tools or hammers, always switch the ignition OFF, disconnect the battery, and wait at least 3 minutes before performing any service.

Precaution for Power Generation Voltage Variable Control System

INFOID:000000005242975

CAUTION:

For this model, the battery current sensor that is installed to the battery cable at the negative terminal measures the charging/discharging current of the battery, and performs various controls. If the electrical component or the ground wire is connected directly to the battery terminal, the current other than that being measured with the battery current sensor is charging to or discharging from the battery. This condition causes the malfunction of the control, and then the battery discharge may occur. Do not connect the electrical component or the ground wire directly to the battery terminal.

PREPARATION

< PREPARATION >

PREPARATION

PREPARATION

Special Service Tools

INFOID:000000005242976

Tool number (Kent-Moore No.) Tool name	Description
<p>— (J-44373 Model MCR620) Starting/Charging System Tester</p>  <p>SEL403X</p>	<p>Tests starting and charging systems. For operating instructions, refer to Technical Service Bulletin.</p>

Commercial Service Tools

INFOID:000000005242977

Tool name	Description
<p>Power tool</p>  <p>PIIB1407E</p>	<p>Loosening bolts, nuts and screws</p>

A

B

C

D

E

F

G

H

I

J

K

L

CHG

N

O

P

CHARGING SYSTEM PRELIMINARY INSPECTION

< PERIODIC MAINTENANCE >

PERIODIC MAINTENANCE

CHARGING SYSTEM PRELIMINARY INSPECTION

Inspection Procedure

INFOID:000000005242978

1. CHECK BATTERY TERMINALS CONNECTION

Check if battery terminals are clean and tight.

Is the inspection result normal?

YES >> GO TO 2.

NO >> Repair battery terminals connection.

2. CHECK FUSE

Check for blown fuse and fusible link.

Unit	Power source (Power supply terminals)	Fuse No.
Alternator	Battery ("S" terminal)	31
Combination meter	Ignition switch ON ("L" terminal)	4

Is the inspection result normal?

YES >> GO TO 3.

NO >> Be sure to eliminate the cause of malfunction before installing new fuse.

3. CHECK "E" TERMINAL CONNECTION

Check if "E" terminal (alternator ground harness) is clean and tight.

Is the inspection result normal?

YES >> GO TO 4.

NO >> Repair "E" terminal connection.

4. CHECK DRIVE BELT TENSION

Check drive belt tension.

- VQ35HR [EM-15, "Checking"](#).
- VK50VE [EM-163, "Checking"](#).

Is the inspection result normal?

YES >> INSPECTION END

NO >> Repair as needed.

POWER GENERATION VOLTAGE VARIABLE CONTROL SYSTEM OPERATION INSPECTION

< PERIODIC MAINTENANCE >

POWER GENERATION VOLTAGE VARIABLE CONTROL SYSTEM OPERATION INSPECTION

Inspection Procedure

INFOID:000000005242979

CAUTION:

When performing this inspection, always use a charged battery that has completed the battery inspection. (When the charging rate of the battery is low, the response speed of the voltage change will become slow. This can cause an incorrect inspection.)

1. CHECK ECM (CONSULT-III)

Perform ECM self-diagnosis with CONSULT-III. Refer to the following.

- VQ35HR models: [EC-124, "CONSULT-III Function"](#).
- VK50VE models: [EC-718, "CONSULT-III Function"](#).

Self-diagnostic results content

No malfunction detected>> GO TO 2.

Malfunction detected>> Check applicable parts, and repair or replace corresponding parts.

2. CHECK OPERATION OF POWER GENERATION VOLTAGE VARIABLE CONTROL SYSTEM

1. Connect CONSULT-III and start the engine.
2. The selector lever is in "P" or "N" position and all of the electric loads and A/C, etc. are turned OFF.
3. Select "ALTERNATOR DUTY" at "Active Test" of "ENGINE", and then check the value of "BATTERY VOLT" monitor when DUTY value of "ALTERNATOR DUTY" is set to 40.0 %.

"BATTERY VOLT"

2 seconds after setting the DUTY value of "ALTERNATOR DUTY" to 40.0 % : 12 - 13.6 V

4. Check the value of "BATTERY VOLT" monitor when DUTY value of "ALTERNATOR DUTY" is set to 80.0%.

"BATTERY VOLT"

20 seconds after setting the DUTY value of "ALTERNATOR DUTY" to 80.0 % : +0.5 V or more against the value of "BATTERY VOLT" monitor when DUTY value is 40.0 %

Is the measurement value within the specification?

YES >> INSPECTION END

NO >> GO TO 3.

3. CHECK IPDM E/R (CONSULT-III)

Perform IPDM E/R self-diagnosis with CONSULT-III. Refer to the following.

- VQ35HR models: [PCS-13, "CONSULT-III Function \(IPDM E/R\)"](#).
- VK50VE models: [PCS-13, "CONSULT-III Function \(IPDM E/R\)"](#).

Self-diagnostic results content

No malfunction detected>> GO TO 4.

Malfunction detected>> Check applicable parts, and repair or replace corresponding parts.

4. CHECK HARNESS BETWEEN ALTERNATOR AND IPDM E/R

1. Turn ignition switch OFF.
2. Disconnect alternator connector and IPDM E/R connector.
3. Check continuity between alternator harness connector and IPDM E/R harness connector.

A
B
C
D
E
F
G
H
I
J
K
L
N
O
P

CHG

POWER GENERATION VOLTAGE VARIABLE CONTROL SYSTEM OPERATION INSPECTION

< PERIODIC MAINTENANCE >

Alternator harness connector		IPDM E/R harness connector		Continuity
Connector	Terminal	Connector	Terminal	
F36	4	E7	76	Existed

4. Check continuity between alternator harness connector and ground.

Alternator harness connector		Ground	Continuity
Connector	Terminal		
F36	4		Not existed

Is the inspection result normal?

YES >> Replace IPDM E/R.

NO >> Repair harness or connector between IPDM E/R and alternator.

ALTERNATOR

< REMOVAL AND INSTALLATION >

REMOVAL AND INSTALLATION

ALTERNATOR

VQ35HR

VQ35HR : Exploded View

INFOID:000000005242980

REMOVAL

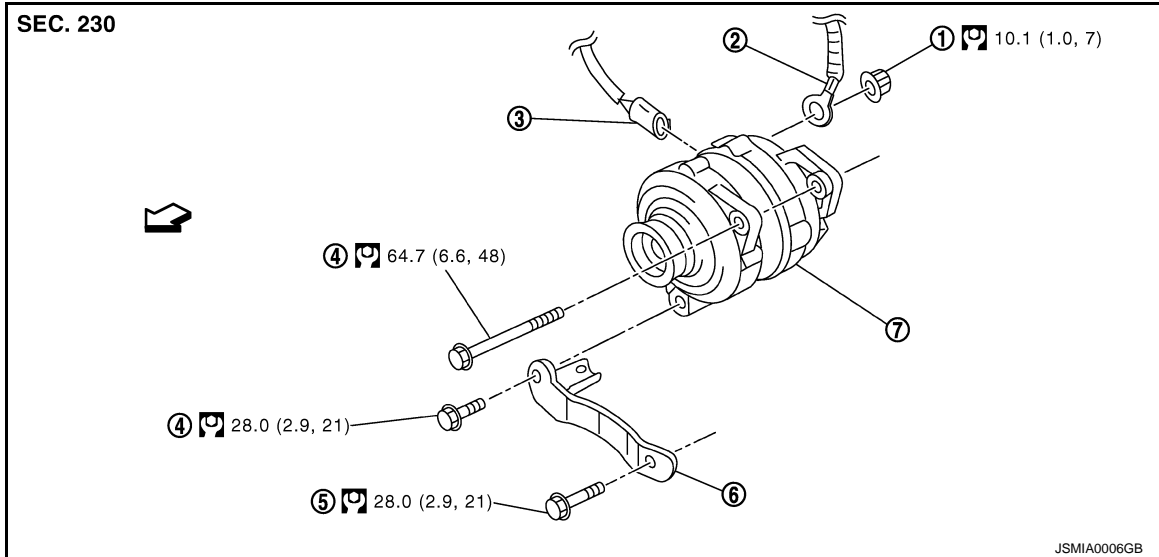

- | | | |
|-----------------------------|----------------------------------|-------------------------|
| 1. "B" terminal nut | 2. "B" terminal harness | 3. Alternator connector |
| 4. Alternator mounting bolt | 5. Alternator stay mounting bolt | 6. Alternator stay |
| 7. Alternator | | |

↔ : Engine front

Refer to [GI-4. "Components"](#) for symbols in the figure.

DISASSEMBLY

A
B
C
D
E
F
G
H
I
J
K
L
N
O
P

CHG

ALTERNATOR

< REMOVAL AND INSTALLATION >

Type: A003TJ1991

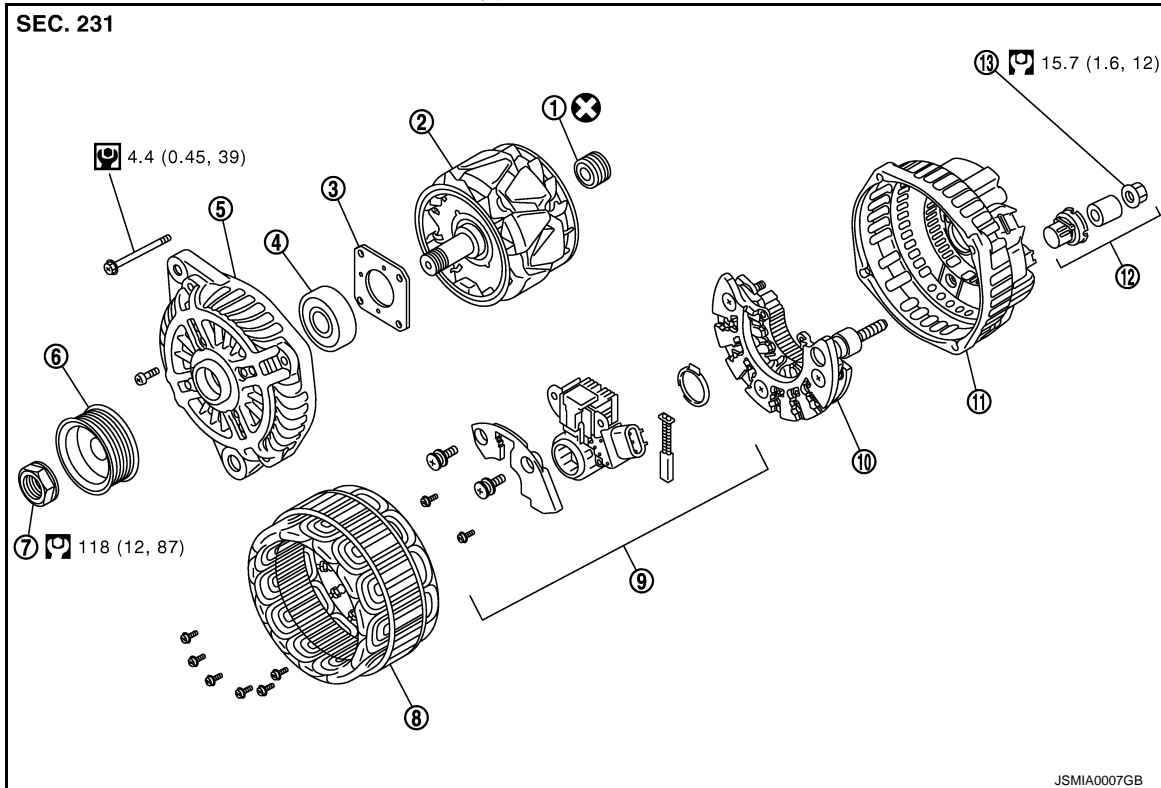

- | | | |
|----------------------|---------------------------|----------------------------------|
| 1. Rear bearing | 2. Rotor assembly | 3. Retainer |
| 4. Front bearing | 5. Front bracket assembly | 6. Pulley |
| 7. Pulley nut | 8. Stator assembly | 9. IC voltage regulator assembly |
| 10. Diode assembly | 11. Rear bracket assembly | 12. Terminal set |
| 13. "B" terminal nut | | |

Refer to [GI-4, "Components"](#) for symbols in the figure.

VQ35HR : Removal and Installation (2WD)

INFOID:000000005242981

REMOVAL

1. Disconnect the battery cable from the negative terminal.
2. Remove engine front undercover, using power tools.
3. Remove drive belt. Refer to [EM-15, "Removal and Installation"](#)
4. Remove the Splash guard (RH).
5. Disconnect alternator connector (1).
6. Remove "B" terminal nut (2).
7. Remove the harness bracket bolts (A).

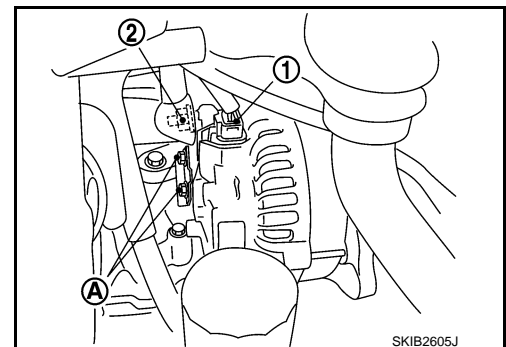

ALTERNATOR

< REMOVAL AND INSTALLATION >

- Remove oil pressure switch harness clip (C) from alternator stay (1).
- Disconnect oil pressure switch connector (D) and oil temperature sensor connector (E).
- Remove alternator mounting bolt (B) and alternator stay mounting bolt (F) using power tools, then remove alternator stay.
- Remove alternator mounting bolt (A), using power tools.

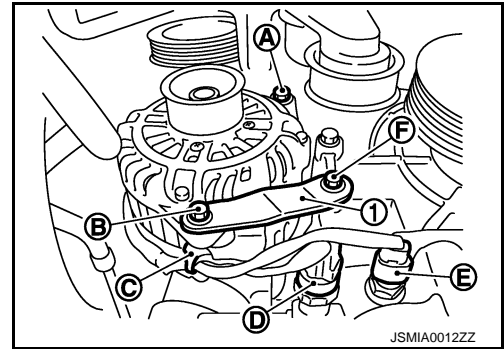

- Move a power steering oil pump hose upward.
- Remove alternator assembly downward from the vehicle.

INSTALLATION

Install in the reverse order of removal.

CAUTION:

Be sure to tighten "B" terminal nut carefully.

- Install alternator, and check tension of belt. Refer to [EM-15, "Checking"](#).
- For this model, the power generation voltage variable control system that controls the power generation voltage of the alternator has been adopted. Therefore, the power generation voltage variable control system operation inspection should be performed after replacing the alternator, and then make sure that the system operates normally. Refer to [CHG-27, "Inspection Procedure"](#).

VQ35HR : Removal and Installation (AWD)

INFOID:000000005242982

REMOVAL

- Disconnect the battery cable from the negative terminal.
- Remove air cleaner case. Refer to [EM-29, "Exploded View"](#).
- Disconnect power steering oil pressure sensor connector (A).
- Remove the clip (B) from the harness bracket (1) and "B" terminal harness from the clip (C).

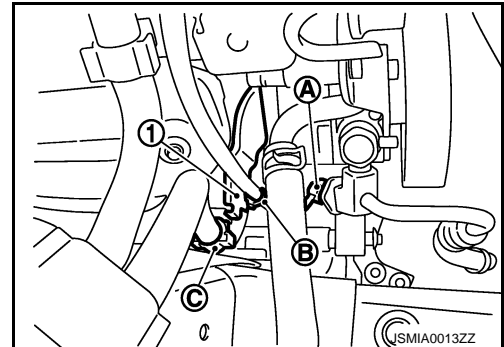

- Remove engine undercover, using power tools.
- Remove drive belt. Refer to [EM-28, "Removal and Installation"](#).
- Remove alternator mounting bolt (B) and alternator stay mounting bolt (C) using power tools, then remove alternator stay (1).
- Remove alternator mounting bolt (A), using power tools.

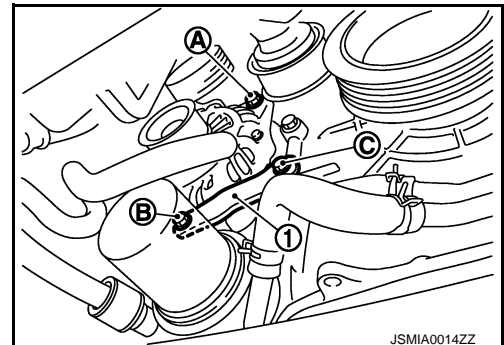

A
B
C
D
E
F
G
H
I
J
K
L

CHG

N
O
P

ALTERNATOR

< REMOVAL AND INSTALLATION >

9. Pull and turn alternator, and then remove the harness bracket bolts (A).
10. Disconnect alternator connector (1).
11. Remove "B" terminal nut (2).

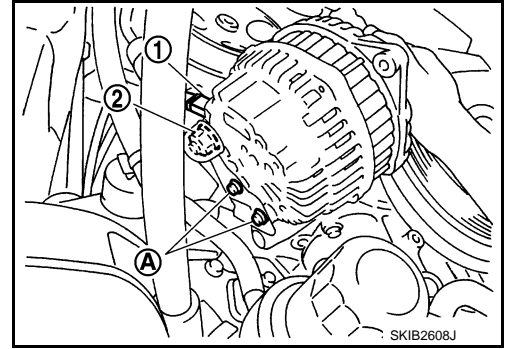

12. Remove power steering oil pump hose bracket bolts (A) and clamp bolts (B).
13. Move a power steering oil pump hose upward.

↶ : Vehicle front

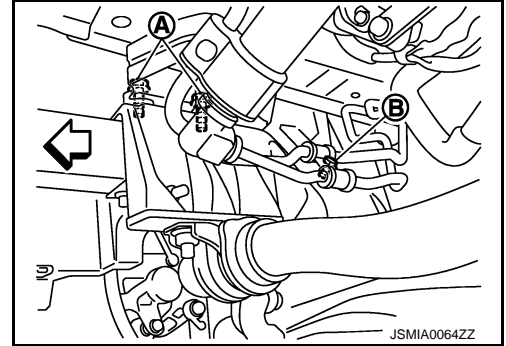

14. Remove alternator assembly downward from the vehicle.

INSTALLATION

Install in the reverse order of removal.

CAUTION:

Be sure to tighten "B" terminal nut carefully.

- Install alternator, and check tension of belt. Refer to [EM-15. "Checking"](#).
- For this model, the power generation voltage variable control system that controls the power generation voltage of the alternator has been adopted. Therefore, the power generation voltage variable control system operation inspection should be performed after replacing the alternator, and then make sure that the system operates normally. Refer to [CHG-27. "Inspection Procedure"](#).

VQ35HR : Inspection

INFOID:000000005242983

ALTERNATOR PULLEY INSPECTION

Perform the following.

- Make sure that alternator pulley does not rattle.
- Make sure that alternator pulley nut is tight. Refer to [CHG-29. "VQ35HR : Exploded View"](#).

VK50VE

VK50VE : Exploded View

INFOID:000000005242984

REMOVAL

ALTERNATOR

< REMOVAL AND INSTALLATION >

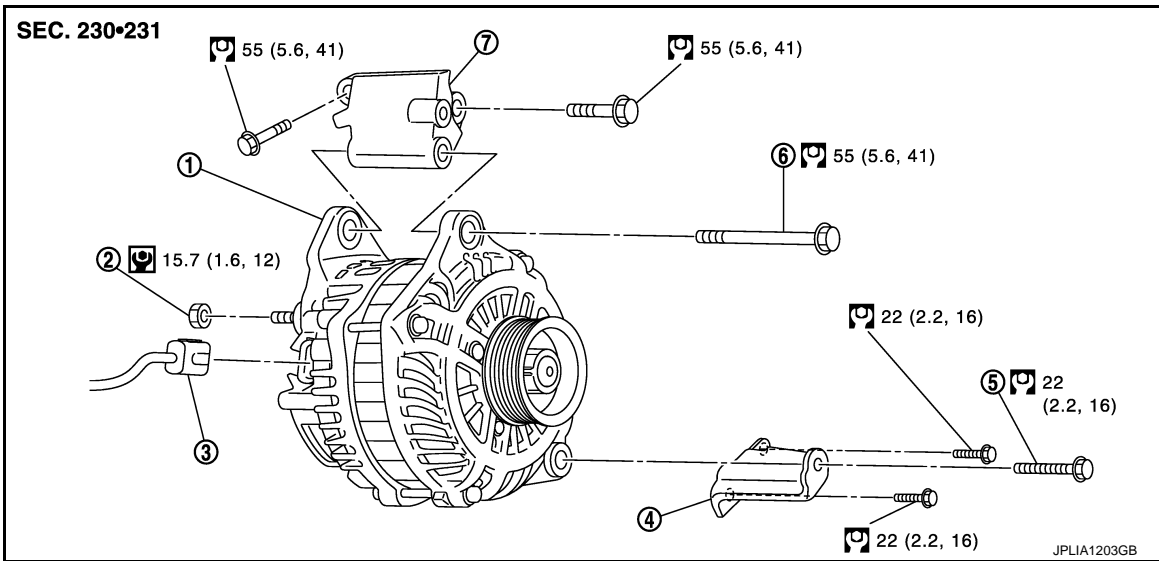

- | | | |
|-----------------------|-----------------------------------|-----------------------------------|
| 1. Alternator | 2. "B" terminal nut | 3. Alternator connector |
| 4. Alternator stay | 5. Alternator mounting lower bolt | 6. Alternator mounting upper bolt |
| 7. Alternator bracket | | |

⇐ : Engine front

Refer to [GI-4, "Components"](#) for symbols in the figure.

DISASSEMBLY

Type: A003TJ3091

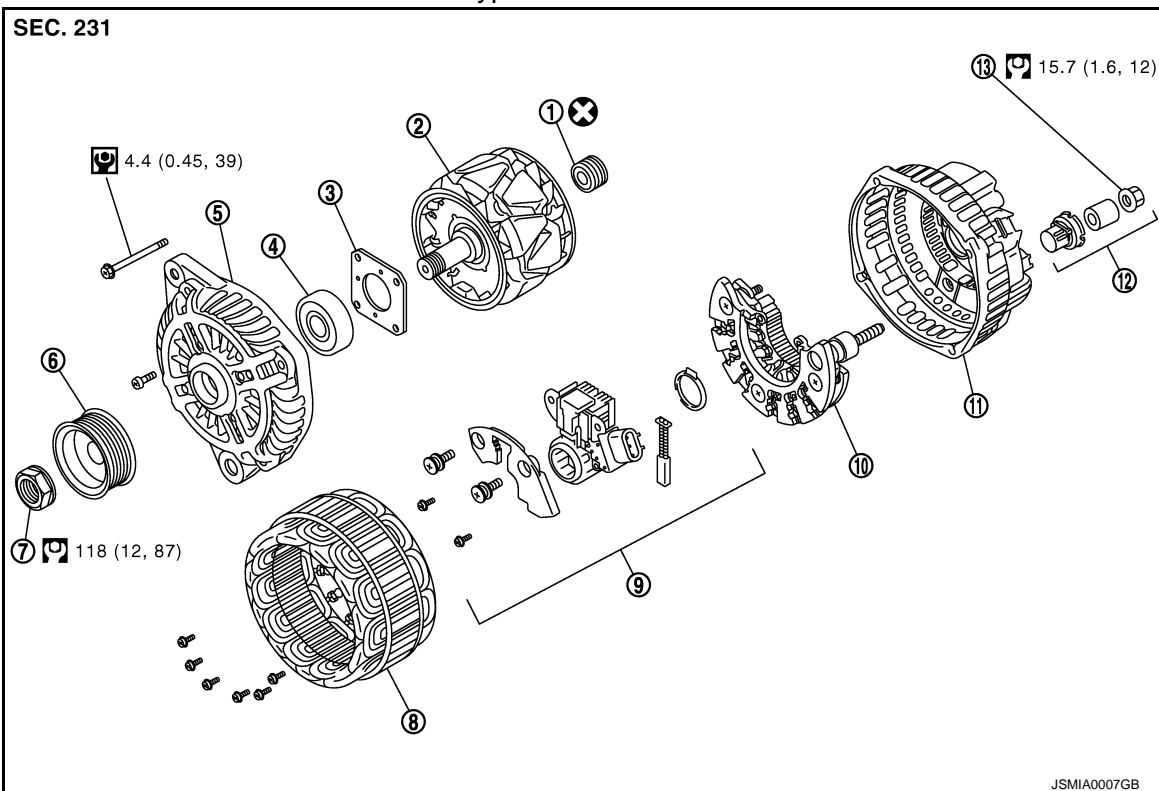

- | | | |
|--------------------|---------------------------|----------------------------------|
| 1. Rear bearing | 2. Rotor assembly | 3. Retainer |
| 4. Front bearing | 5. Front bracket assembly | 6. Pulley |
| 7. Pulley nut | 8. Stator assembly | 9. IC voltage regulator assembly |
| 10. Diode assembly | 11. Rear bracket assembly | 12. Terminal set |

A
B
C
D
E
F
G
H
I
J
K
L
N
O
P

CHG

ALTERNATOR

< REMOVAL AND INSTALLATION >

13. "B" terminal nut

Refer to [GI-4, "Components"](#) for symbols in the figure.

VK50VE : Removal and Installation

INFOID:000000005242985

REMOVAL

1. Disconnect the battery cable from the negative terminal.
2. Remove drive belt. Refer to [EM-176, "Exploded View"](#)
3. Remove the air ducts and air cleaner assembly RH.
4. Remove the alternator connector harness bracket (A).
5. Move a steering hose and harness not to interfere the removal of the alternator.
6. Remove the alternator mounting bolt (B) and alternator mounting bolt (C).

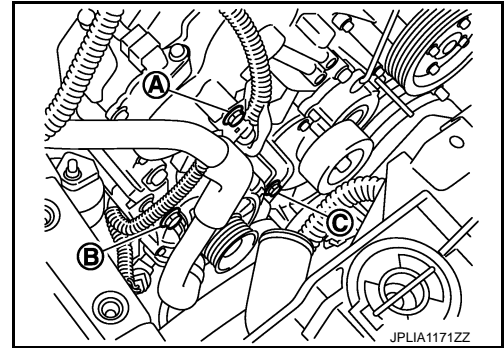

7. Pull and turn alternator, and then remove the "B" terminal nut (A) and alternator connector (B).

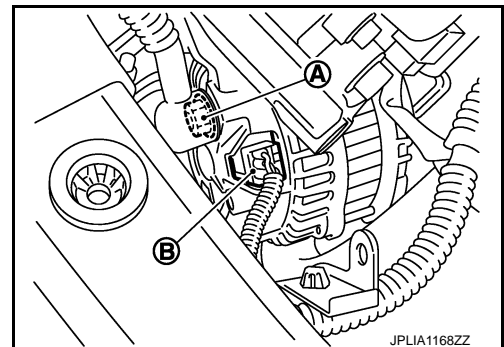

8. Remove alternator assembly (1) upward from the vehicle.

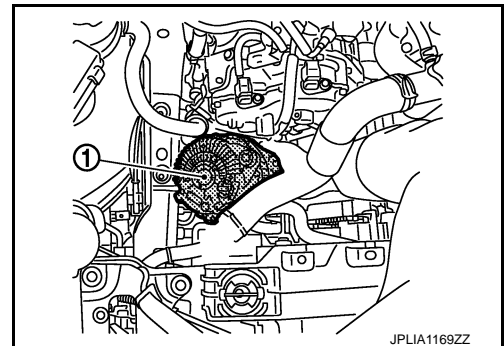

INSTALLATION

Install in the reverse order of removal.

CAUTION:

Be sure to tighten "B" terminal nut carefully.

- Install alternator, and check tension of belt. Refer to [EM-163, "Checking"](#).
- For this model, the power generation voltage variable control system that controls the power generation voltage of the alternator has been adopted. Therefore, the power generation voltage variable control system operation inspection should be performed after replacing the alternator, and then make sure that the system operates normally. Refer to [CHG-27, "Inspection Procedure"](#).

VK50VE : Inspection

INFOID:000000005242986

ALTERNATOR PULLEY INSPECTION

Perform the following.

ALTERNATOR

< REMOVAL AND INSTALLATION >

- Make sure that alternator pulley does not rattle.
- Make sure that alternator pulley nut is tight. Refer to [CHG-32, "VK50VE : Exploded View"](#).

A

B

C

D

E

F

G

H

I

J

K

L

CHG

N

O

P

SERVICE DATA AND SPECIFICATIONS (SDS)

< SERVICE DATA AND SPECIFICATIONS (SDS)

SERVICE DATA AND SPECIFICATIONS (SDS)

SERVICE DATA AND SPECIFICATIONS (SDS)

Alternator

INFOID:000000005242987

	VQ35HR	VK50VE
Type	A003TJ1991	A003TJ3091
	MITSUBISHI make	
Nominal rating [V - A]	12 -150	
Ground polarity	Negative	
Minimum revolution under no-load (When 13.5 V is applied) [rpm]	Less than 1,300	
Hot output current (When 13.5 V is applied) [A/rpm]	More than 31/1,300 More than 122/2,500 More than 144/5,000	
Regulated output voltage [V]	14.1 – 14.7*	
Minimum length of brush [mm (in)]	More than 5.00 (0.197)	
Brush spring pressure [N (g, oz)]	4.1 – 5.3 (418 – 541, 14.7 – 19.1)	
Slip ring minimum outer diameter [mm (in)]	More than 22.1 (0.870)	
Rotor (Field coil) resistance [Ω]	1.7 – 2.0	

*: Adjustment range of power generation voltage variable control is 11.4 - 15.6 V.