

SECTION **FSU**
FRONT SUSPENSION

A
B
C
D

FSU

CONTENTS

2WD		
SYMPTOM DIAGNOSIS	3	
NOISE, VIBRATION AND HARSHNESS (NVH) TROUBLESHOOTING	3	
NVH Troubleshooting Chart	3	
PRECAUTION	4	
PRECAUTIONS	4	
Precaution for Supplemental Restraint System (SRS) "AIR BAG" and "SEAT BELT PRE-TENSIONER"	4	
Precautions Necessary for Steering Wheel Rotation After Battery Disconnection	4	
Precaution for Procedure without Cowl Top Cover.....	5	
Precautions for Suspension	5	
PREPARATION	6	
PREPARATION	6	
Special Service Tool	6	
Commercial Service Tool	6	
PERIODIC MAINTENANCE	7	
FRONT SUSPENSION ASSEMBLY	7	
Inspection	7	
WHEEL ALIGNMENT	8	
Inspection	8	
Adjustment	8	
REMOVAL AND INSTALLATION	10	
FRONT COIL SPRING AND SHOCK ABSORBER	10	
Exploded View	10	
Removal and Installation	10	
Disassembly and Assembly	10	
Inspection	13	
Disposal	13	F
TRANSVERSE LINK	14	
Exploded View	14	G
Removal and Installation	14	
Inspection	14	
UPPER LINK	16	H
Exploded View	16	
Removal and Installation	16	
Inspection	16	I
FRONT STABILIZER	18	
Exploded View	18	J
Removal and Installation	18	
Inspection	18	
UNIT REMOVAL AND INSTALLATION	19	K
FRONT SUSPENSION MEMBER	19	
Exploded View	19	L
Removal and Installation	19	
Inspection	19	
SERVICE DATA AND SPECIFICATIONS (SDS)	20	M
SERVICE DATA AND SPECIFICATIONS (SDS)	20	N
Wheel Alignment	20	
Ball Joint	20	
Wheel Height	21	O
AWD		
SYMPTOM DIAGNOSIS	22	P
NOISE, VIBRATION AND HARSHNESS (NVH) TROUBLESHOOTING	22	
NVH Troubleshooting Chart	22	
PRECAUTION	23	

PRECAUTIONS	23	Disposal	32
Precaution for Supplemental Restraint System (SRS) "AIR BAG" and "SEAT BELT PRE-TENSIONER"	23	TRANSVERSE LINK	34
Precautions Necessary for Steering Wheel Rotation After Battery Disconnection	23	Exploded View	34
Precaution for Procedure without Cowl Top Cover..	24	Removal and Installation	34
Precautions for Suspension	24	Inspection	34
PREPARATION	25	UPPER LINK	36
PREPARATION	25	Exploded View	36
Special Service Tool	25	Removal and Installation	36
Commercial Service Tool	25	Inspection	36
PERIODIC MAINTENANCE	26	FRONT STABILIZER	38
FRONT SUSPENSION ASSEMBLY	26	Exploded View	38
Inspection	26	Removal and Installation	38
WHEEL ALIGNMENT	27	Inspection	38
Inspection	27	UNIT REMOVAL AND INSTALLATION	39
Adjustment	27	FRONT SUSPENSION MEMBER	39
REMOVAL AND INSTALLATION	29	Exploded View	39
FRONT COIL SPRING AND SHOCK ABSORBER	29	Removal and Installation	39
Exploded View	29	Inspection	39
Removal and Installation	29	SERVICE DATA AND SPECIFICATIONS (SDS)	41
Disassembly and Assembly	30	SERVICE DATA AND SPECIFICATIONS (SDS)	41
Inspection	32	Wheel Alignment	41
		Ball Joint	41
		Wheel Height	42

NOISE, VIBRATION AND HARSHNESS (NVH) TROUBLESHOOTING

< SYMPTOM DIAGNOSIS >

[2WD]

SYMPTOM DIAGNOSIS

NOISE, VIBRATION AND HARSHNESS (NVH) TROUBLESHOOTING

NVH Troubleshooting Chart

INFOID:000000006566811

Use chart below to find the cause of the symptom. If necessary, repair or replace these parts.

Symptom		Possible cause and SUSPECTED PARTS	Reference													
			FSU-10, FSU-14, FSU-16, FSU-18, FSU-19	FSU-13	—	—	—	FSU-10, FSU-14, FSU-16, FSU-18, FSU-19	FSU-8	FSU-18	NVH in DLN section	NVH in FAX and FSU section	NVH in WT section	NVH in BR section	NVH in ST section	
Symptom	FRONT SUSPENSION	Noise	x	x	x	x	x	x	x			x	x	x	x	x
		Shake	x	x	x	x		x				x	x	x	x	x
		Vibration	x	x	x	x	x					x	x			x
		Shimmy	x	x	x	x				x			x	x	x	x
		Judder	x	x	x								x	x	x	x
		Poor quality ride or handling	x	x	x	x	x		x	x			x	x		

x: Applicable

A
B
C
D
E
F
G
H
I
J
K
L
M
N
O
P

FSU

PRECAUTION

PRECAUTIONS

Precaution for Supplemental Restraint System (SRS) "AIR BAG" and "SEAT BELT PRE-TENSIONER"

INFOID:000000006566812

The Supplemental Restraint System such as "AIR BAG" and "SEAT BELT PRE-TENSIONER", used along with a front seat belt, helps to reduce the risk or severity of injury to the driver and front passenger for certain types of collision. This system includes seat belt switch inputs and dual stage front air bag modules. The SRS system uses the seat belt switches to determine the front air bag deployment, and may only deploy one front air bag, depending on the severity of a collision and whether the front occupants are belted or unbelted. Information necessary to service the system safely is included in the "SRS AIR BAG" and "SEAT BELT" of this Service Manual.

WARNING:

Always observe the following items for preventing accidental activation.

- To avoid rendering the SRS inoperative, which could increase the risk of personal injury or death in the event of a collision that would result in air bag inflation, all maintenance must be performed by an authorized NISSAN/INFINITI dealer.
- Improper maintenance, including incorrect removal and installation of the SRS, can lead to personal injury caused by unintentional activation of the system. For removal of Spiral Cable and Air Bag Module, see "SRS AIR BAG".
- Never use electrical test equipment on any circuit related to the SRS unless instructed to in this Service Manual. SRS wiring harnesses can be identified by yellow and/or orange harnesses or harness connectors.

PRECAUTIONS WHEN USING POWER TOOLS (AIR OR ELECTRIC) AND HAMMERS

WARNING:

Always observe the following items for preventing accidental activation.

- When working near the Air Bag Diagnosis Sensor Unit or other Air Bag System sensors with the ignition ON or engine running, never use air or electric power tools or strike near the sensor(s) with a hammer. Heavy vibration could activate the sensor(s) and deploy the air bag(s), possibly causing serious injury.
- When using air or electric power tools or hammers, always switch the ignition OFF, disconnect the battery, and wait at least 3 minutes before performing any service.

Precautions Necessary for Steering Wheel Rotation After Battery Disconnection

INFOID:000000006566813

CAUTION:

Comply with the following cautions to prevent any error and malfunction.

- Before removing and installing any control units, first turn the ignition switch to the LOCK position, then disconnect both battery cables.
- After finishing work, confirm that all control unit connectors are connected properly, then re-connect both battery cables.
- Always use CONSULT to perform self-diagnosis as a part of each function inspection after finishing work. If a DTC is detected, perform trouble diagnosis according to self-diagnosis results.

For vehicle with steering lock unit, if the battery is disconnected or discharged, the steering wheel will lock and cannot be turned.

If turning the steering wheel is required with the battery disconnected or discharged, follow the operation procedure below before starting the repair operation.

OPERATION PROCEDURE

1. Connect both battery cables.

NOTE:

Supply power using jumper cables if battery is discharged.

2. Turn the ignition switch to ACC position.
(At this time, the steering lock will be released.)
3. Disconnect both battery cables. The steering lock will remain released with both battery cables disconnected and the steering wheel can be turned.

PRECAUTIONS

[2WD]

< PRECAUTION >

4. Perform the necessary repair operation.
5. When the repair work is completed, re-connect both battery cables. With the brake pedal released, turn the ignition switch from ACC position to ON position, then to LOCK position. (The steering wheel will lock when the ignition switch is turned to LOCK position.)
6. Perform self-diagnosis check of all control units using CONSULT.

Precaution for Procedure without Cowl Top Cover

INFOID:000000006566814

When performing the procedure after removing cowl top cover, cover the lower end of windshield with urethane, etc to prevent damage to windshield.

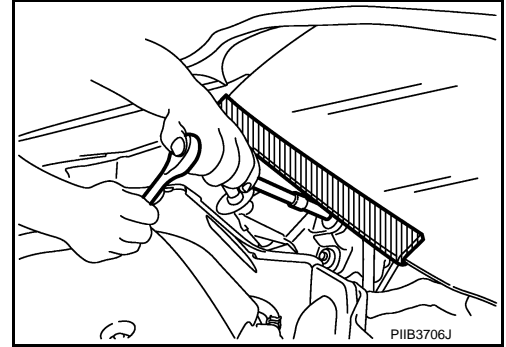

Precautions for Suspension

INFOID:000000006566815

CAUTION:

- When installing rubber bushings, the final tightening must be carried out under unladen conditions with tires on ground. Spilled oil might shorten the life of rubber bushings. Be sure to wipe off any spilled oil.
- Unladen conditions mean that fuel, engine coolant and lubricant are full. Spare tire, jack, hand tools and mats are in designated positions.
- After servicing suspension parts, be sure to check wheel alignment.
- Self-lock nuts are not reusable. Always use new ones when installing. Since new self-lock nuts are pre-oiled, tighten as they are.

PREPARATION

< PREPARATION >

[2WD]

PREPARATION

PREPARATION

Special Service Tool

INFOID:000000006566816

The actual shapes of Kent-Moore tools may differ from those of special service tools illustrated here.

Tool number (Kent-Moore No.) Tool name	Description
ST35652000 (-) Shock absorber attachment	Disassembling and assembling shock absorber
ST3127S000 (J-25765-A) Preload gauge	Measuring rotating torque of ball joint

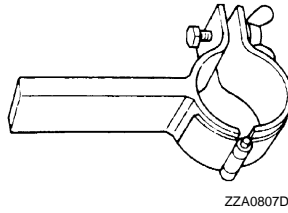

ZZA0807D

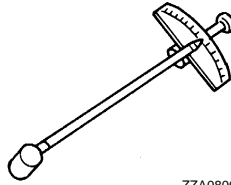

ZZA0806D

Commercial Service Tool

INFOID:000000006566817

Tool name	Description
Power tool	Loosening bolts and nuts
Spring compressor	Removing and installing coil spring

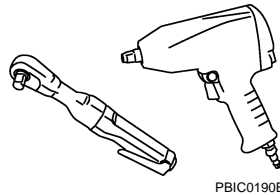

PBIC0190E

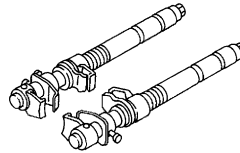

S-NT717

FRONT SUSPENSION ASSEMBLY

< PERIODIC MAINTENANCE >

[2WD]

PERIODIC MAINTENANCE

FRONT SUSPENSION ASSEMBLY

Inspection

INFOID:000000006566818

COMPONENT PART

Check the mounting conditions (looseness, backlash) of each component and component conditions (wear, damage) are normal.

Ball Joint Axial End Play

1. Set front wheels in a straight-ahead position.
2. Move axle side of transverse link and upper link in the axial direction by hand. Check there is no end play.

Axial end play : Refer to [FSU-20. "Ball Joint"](#).

CAUTION:

- Never depress brake pedal when measuring.
- Never perform with tires on level ground.
- Be careful not to damage ball joint boot. Never damage the installation position by applying excessive force.

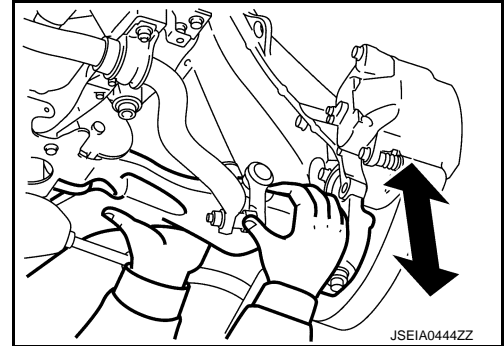

SHOCK ABSORBER

Check for oil leakage, damage. Replace it if necessary.

A
B
C
D
FSU
F
G
H
I
J
K
L
M
N
O
P

WHEEL ALIGNMENT

Inspection

INFOID:000000006566819

DESCRIPTION

CAUTION:

- **Camber, caster, kingpin inclination angles cannot be adjusted.**
- **If camber, caster, or kingpin inclination angle is outside the standard, check front suspension parts for wear and damage. Replace suspect parts if a malfunction is detected.**
- **Kingpin inclination angle is reference value, no inspection is required.**
- Measure wheel alignment under unladen conditions.

NOTE:

“Unladen conditions” means that fuel, engine coolant, and lubricant are full. Spare tire, jack, hand tools and mats are in designated positions.

PRELIMINARY CHECK

Check the following:

- Tires for improper air pressure and wear. Refer to [WT-85, "Tire Air Pressure"](#).
- Road wheels for runout.
- Wheel bearing axial end play. Refer to [FAX-5, "Inspection"](#).
- Transverse link or upper link ball joint axial end play.
- Shock absorber operation.
- Each mounting part of axle and suspension for looseness and deformation.
- Each of suspension member, shock absorber, upper link and transverse link for cracks, deformation and other damage.
- Vehicle height (posture).

GENERAL INFORMATION AND RECOMMENDATIONS

- A four-wheel thrust alignment should be performed.
- This type of alignment is recommended for any NISSAN/INFINITI vehicle.
- The four-wheel “thrust” process helps ensure that the vehicle is properly aligned and the steering wheel is centered.
- The alignment rack itself should be capable of accepting any NISSAN/INFINITI vehicle.
- The rack should be checked to ensure that it is level.
- Make sure the machine is properly calibrated.
- Your alignment equipment should be regularly calibrated in order to give correct information.
- Check with the manufacturer of your specific equipment for their recommended Service/Calibration Schedule.

ALIGNMENT PROCESS

IMPORTANT:

Use only the alignment specifications listed in this Service Manual.

- When displaying the alignment settings, many alignment machines use “indicators”: (Green/red, plus or minus, Go/No Go). **Do not use these indicators.**
- The alignment specifications programmed into your machine that operate these indicators may not be correct.
- This may result in an ERROR.
- Most camera-type alignment machines are equipped with both “Rolling Compensation” method and optional “Jacking Compensation” method to “compensate” the alignment targets or head units. “Rolling Compensation” is the preferred method.
- If using the “Rolling Compensation” method, after installing the alignment targets or head units, push or pull on the rear wheel to move the vehicle. **Do not push or pull on the vehicle body.**
- If using the “Jacking Compensation” method, after installing the alignment targets or head units, raise the vehicle and rotate the wheels 1/2 turn both ways.

NOTE:

- Do not use the “Rolling Compensation” method if you are using sensor-type alignment equipment.
- Follow all instructions for the alignment machine you're using for more information.

Adjustment

INFOID:000000008145954

TOE-IN

WHEEL ALIGNMENT

< PERIODIC MAINTENANCE >

[2WD]

- Loosen the steering outer socket, and then adjust the length using steering inner socket.

Toe-in : Refer to [FSU-20, "Wheel Alignment"](#).

CAUTION:

- Always evenly adjust both toe-in alternately and adjust the difference between the left and right to the standard.
- Always fix the steering inner socket when tightening the steering outer socket.
- After toe-in adjustment, adjust neutral position of steering angle sensor. Refer to [BRC-10, "ADJUSTMENT OF STEERING ANGLE SENSOR NEUTRAL POSITION : Special Repair Requirement"](#).

A
B
C
D
E
F
G
H
I
J
K
L
M
N
O
P

FSU

FRONT COIL SPRING AND SHOCK ABSORBER

< REMOVAL AND INSTALLATION >

[2WD]

REMOVAL AND INSTALLATION

FRONT COIL SPRING AND SHOCK ABSORBER

Exploded View

INFOID:000000006566820

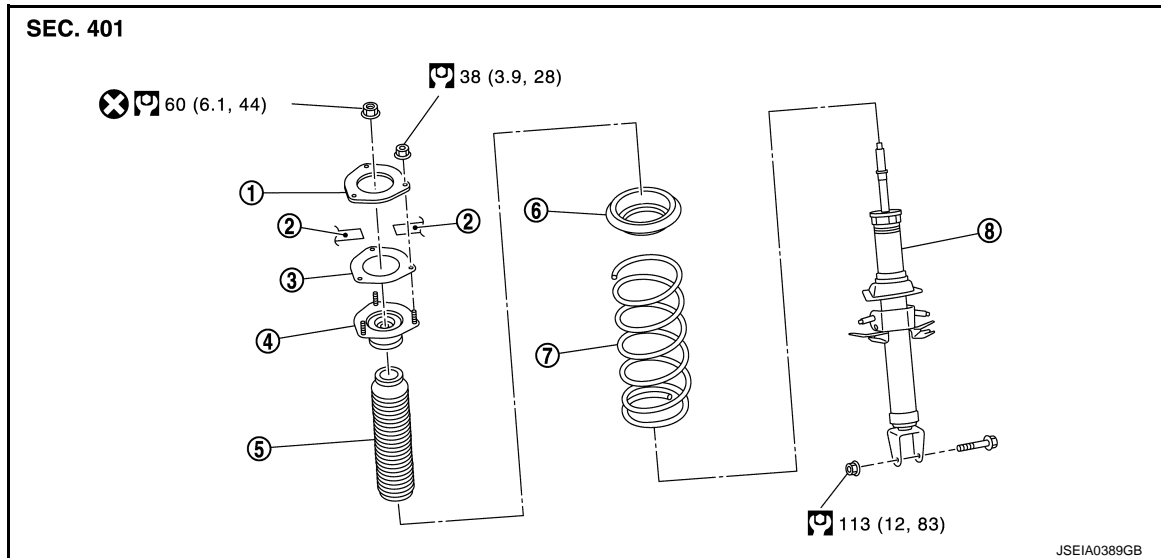

- | | | |
|------------------------------------|-------------------|------------------|
| 1. Gusset | 2. Vehicle body | 3. Mounting seal |
| 4. Shock absorber mounting bracket | 5. Bound bumper | 6. Rubber seat |
| 7. Coil spring | 8. Shock absorber | |

Refer to [GI-4, "Components"](#) for symbols in the figure.

Removal and Installation

INFOID:000000006566821

REMOVAL

1. Remove tires with power tool.
2. Remove wheel sensor and harness connector from shock absorber. Refer to [BRC-150, "FRONT WHEEL SENSOR : Exploded View"](#).

CAUTION:

Never pull on wheel sensor harness.

3. Remove brake hose bracket. Refer to [BR-20, "FRONT : Exploded View"](#).
4. Remove shock absorber from transverse link with power tool.
5. Separate upper link from steering knuckle. Refer to [FAX-6, "Exploded View"](#)
6. Remove shock absorber mounting bracket mounting nuts, and remove shock absorber assembly.

NOTE:

If removing shock absorber is difficult, loosen upper link mounting bolts (vehicle side).

INSTALLATION

Note the following, and install in the reverse order of removal.

- Never tap on the ball joint cap of the stabilizer connecting rod with a hammer or a similar item when inserting the stabilizer connecting rod into the transverse link.
- Perform final tightening of bolts and nuts at the shock absorber lower side (rubber bushing), under unladen conditions with tires on level ground.

Disassembly and Assembly

INFOID:000000006566822

DISASSEMBLY

CAUTION:

Never damage shock absorber piston rod when removing components from shock absorber.

FRONT COIL SPRING AND SHOCK ABSORBER

< REMOVAL AND INSTALLATION >

[2WD]

1. Install shock absorber attachment (A) [SST: ST35652000 (-)] to shock absorber and secure it in a vise.

CAUTION:

When installing the shock absorber attachment to shock absorber, wrap a shop cloth around shock absorber to protect it from damage.

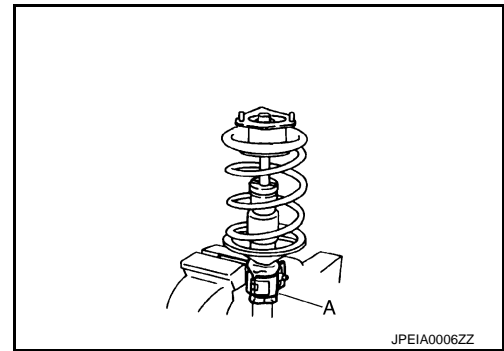

2. Using a spring compressor (A) (commercial service tool), compress coil spring between rubber seat and shock absorber until coil spring with a spring compressor is free.

CAUTION:

Be sure a spring compressor is securely attached coil spring. Compress coil spring.

3. Make sure coil spring with a spring compressor between rubber seat and shock absorber is free. And then remove piston rod lock nut while securing the piston rod tip so that piston rod does not turn.
4. Remove mounting seal, shock absorber mounting bracket, rubber seat, bound bumper from shock absorber.

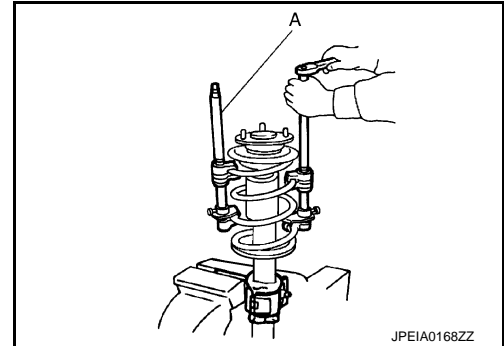

5. After removing coil spring with a spring compressor, then gradually release a spring compressor.

CAUTION:

Loosen while making sure coil spring attachment position does not move.

6. Remove the shock absorber attachment from shock absorber.

ASSEMBLY

1. Install shock absorber attachment (A) [SST: ST35652000 (-)] to shock absorber and secure it in a vise.

CAUTION:

When installing the shock absorber attachment to shock absorber, wrap a shop cloth around shock absorber to protect it from damage.

2. Compress coil spring using a spring compressor (commercial service tool), and install it onto shock absorber.

CAUTION:

- Install with the large-diameter side (A) facing up and the small-diameter side (B) facing down.
- Be sure a spring compressor is securely attached to coil spring. Compress coil spring.

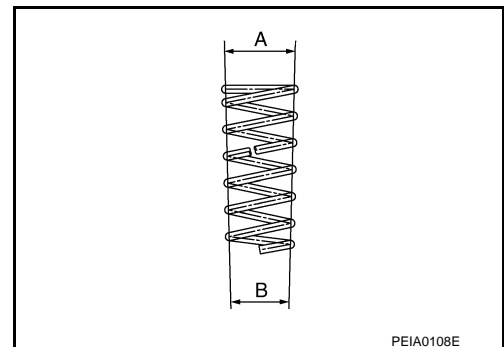

A
B
C
D
FSU
F
G
H
I
J
K
L
M
N
O
P

FRONT COIL SPRING AND SHOCK ABSORBER

< REMOVAL AND INSTALLATION >

[2WD]

3. Install the shock absorber mounting bracket and rubber seat.
CAUTION:
Align the paint mark (A) to the stud bolt (1) position when assembling.
4. Apply soapy water to bound bumper.
CAUTION:
Never use machine oil.

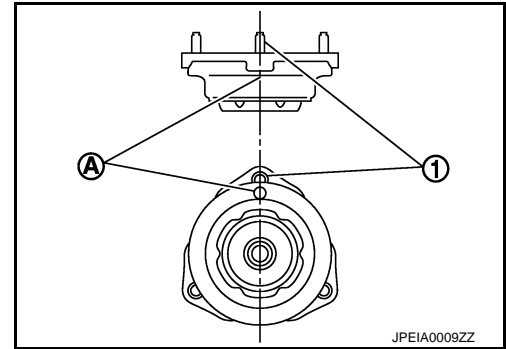

5. Insert bound bumper into shock absorber mounting bracket, and then install it to shock absorber together with rubber seat.

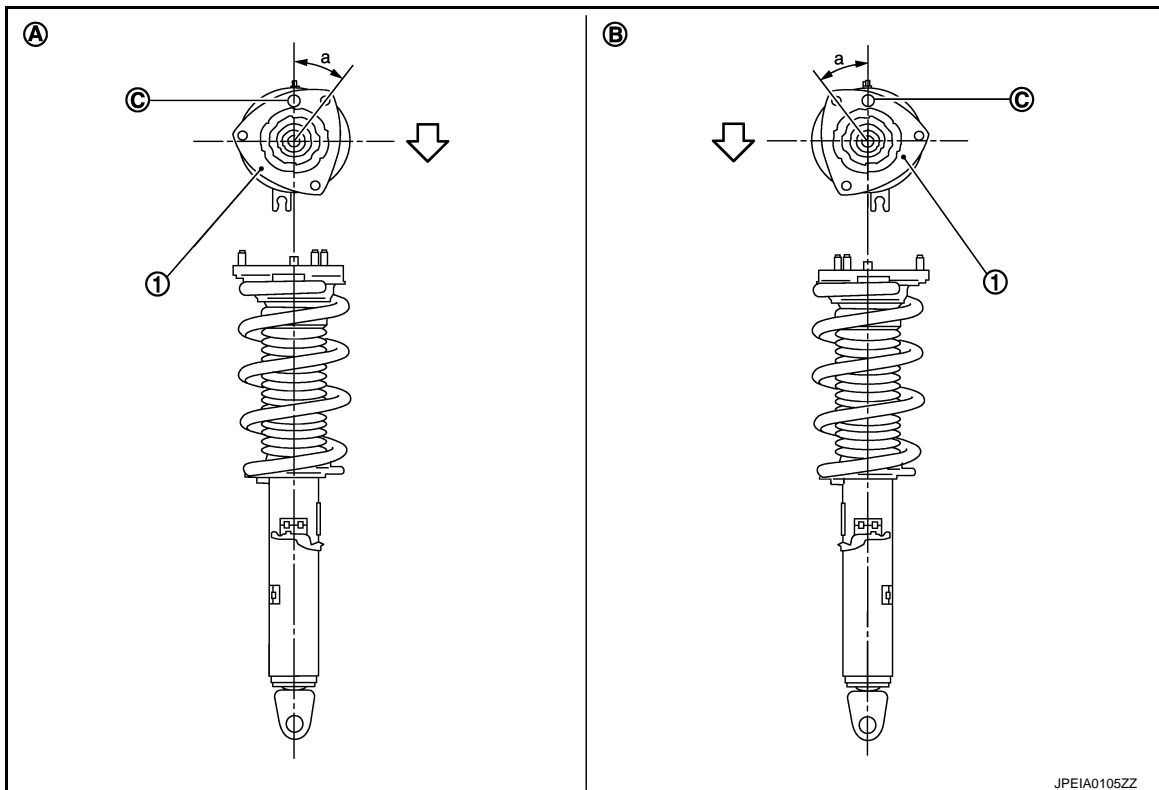

1. Shock absorber mounting bracket
 A. Right side B. Left side C. Coil spring lower end position

⇐ : Vehicle front

- Install the shock absorber mounting bracket as shown in the figure.

Angle (a) : 30.0°

- Check that the lower end of the coil spring (C) is positioned at the spring lower seat of the shock absorber.
6. Secure piston rod tip so that piston rod does not turn, then tighten piston rod lock nut with specified torque.
 7. Gradually release a spring compressor, and remove coil spring.
CAUTION:
Loosen while making sure coil spring attachment position does not move.
 8. Remove the shock absorber attachment from shock absorber.
 9. Install the mounting seal to shock absorber mounting bracket.

FRONT COIL SPRING AND SHOCK ABSORBER

< REMOVAL AND INSTALLATION >

[2WD]

Inspection

INFOID:000000006566823

INSPECTION AFTER INSTALLATION

1. Check wheel sensor harness for proper connection. Refer to [BRC-150. "FRONT WHEEL SENSOR : Exploded View"](#).
2. Check wheel alignment. Refer to [FSU-8. "Inspection"](#).
3. Adjust neutral position of steering angle sensor. Refer to [BRC-10. "ADJUSTMENT OF STEERING ANGLE SENSOR NEUTRAL POSITION : Special Repair Requirement"](#).

INSPECTION AFTER DISASSEMBLY

Shock Absorber

Check the following items, and replace the part if necessary.

- Shock absorber for deformation, cracks or damage.
- Piston rod for damage, uneven wear or distortion.
- Oil leakage.

Shock Absorber Mounting Bracket and Rubber Parts Inspection

Check shock absorber mounting bracket for cracks and rubber parts for wear. Replace it if necessary.

Coil Spring

Check coil spring for cracks, wear or damage. Replace it if necessary.

Disposal

INFOID:000000006566824

1. Set shock absorber horizontally with the piston rod fully extended.
2. Drill 2 – 3 mm (0.08 – 0.12 in) hole at the position (●) from top as shown in the figure to release gas gradually.

CAUTION:

- **Wear eye protection (safety glasses).**
- **Wear gloves.**
- **Be careful with metal chips or oil blown out by the compressed gas.**

NOTE:

- Drill vertically in this direction (←).
- Directly to the outer tube avoiding brackets.
- The gas is clear, colorless, odorless, and harmless.

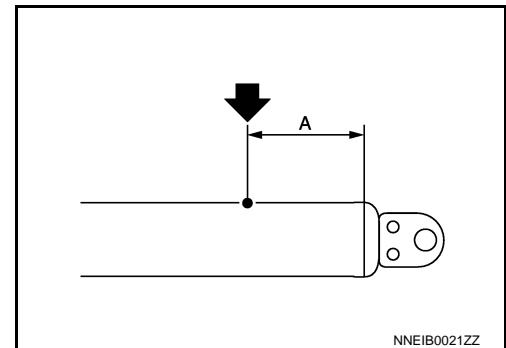

A : 20 – 30 mm (0.79 – 1.18 in)

3. Position the drilled hole downward and drain oil by moving the piston rod several times.

CAUTION:

Dispose of drained oil according to the law and local regulations.

TRANSVERSE LINK

< REMOVAL AND INSTALLATION >

[2WD]

TRANSVERSE LINK

Exploded View

INFOID:000000006566825

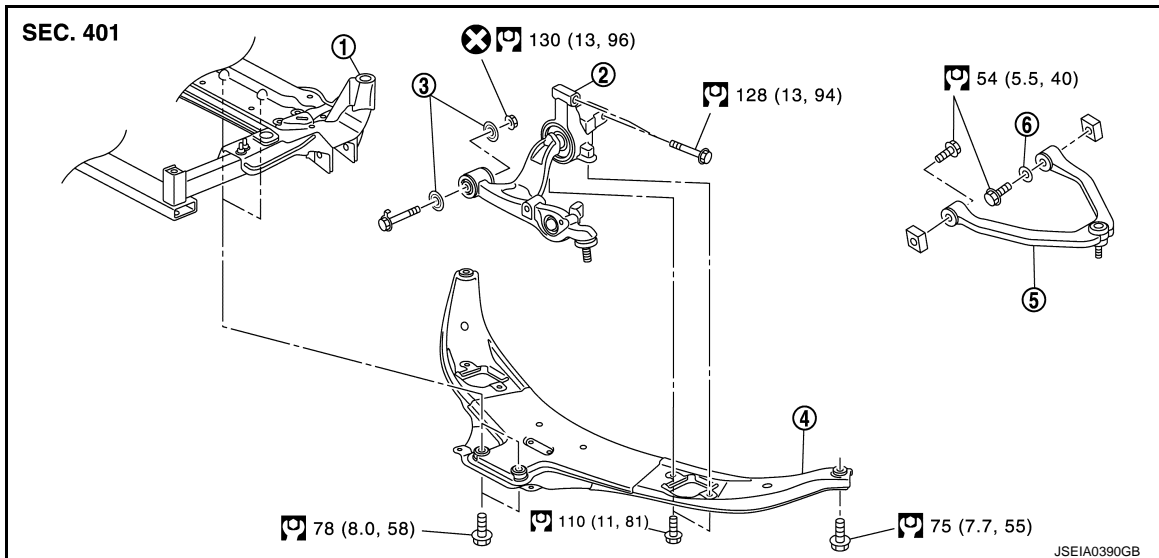

- | | | |
|----------------------------|--------------------|------------------------|
| 1. Front suspension member | 2. Transverse link | 3. Stopper bushing |
| 4. Front cross bar | 5. Upper link | 6. Stopper arm bushing |

Refer to [GI-4, "Components"](#) for symbols in the figure.

Removal and Installation

INFOID:000000006566826

REMOVAL

1. Remove tires with power tool.
2. Remove shock absorber. Refer to [FSU-10, "Exploded View"](#).
3. Temporarily install upper link and steering knuckle. Refer to [FAX-6, "Exploded View"](#).
4. Remove stabilizer connecting rod. Refer to [FSU-18, "Exploded View"](#).
5. Remove front cross bar.
6. Remove transverse link from steering knuckle.
7. Set suitable jack under transverse link.
8. Remove transverse link and stopper bushings.

NOTE:

If removing transverse link mounting bolt (front side) is difficult, rotating steering wheel and remove steering outer socket. Refer to [ST-26, "Exploded View"](#).

INSTALLATION

Note the following, and install in the reverse order of removal.

- Never tap on the ball joint cap of the stabilizer connecting rod with a hammer or a similar item when inserting the stabilizer connecting rod into the transverse link.
- Perform final tightening of bolts and nuts at the front suspension member installation and shock absorber lower side (rubber bushing), under unladen conditions with tires on level ground.

Inspection

INFOID:000000006566827

INSPECTION AFTER REMOVAL

Appearance

Check the following items, and replace the part if necessary.

- Transverse link and bushing for deformation, cracks or damage.
- Ball joint boot for cracks or other damage, and also for grease leakage.

TRANSVERSE LINK

< REMOVAL AND INSTALLATION >

[2WD]

Ball Joint Inspection

Manually move ball stud to confirm it moves smoothly with no binding.

Swing Torque Inspection

NOTE:

Before measurement, move ball stud at least ten times by hand to check for smooth movement.

- Hook a spring balance (A) at cotter pin mounting hole. Confirm spring balance measurement value is within specifications when ball stud begins moving.

Swing torque : Refer to [FSU-20, "Ball Joint"](#).

- If swing torque exceeds standard range, replace transverse link assembly.

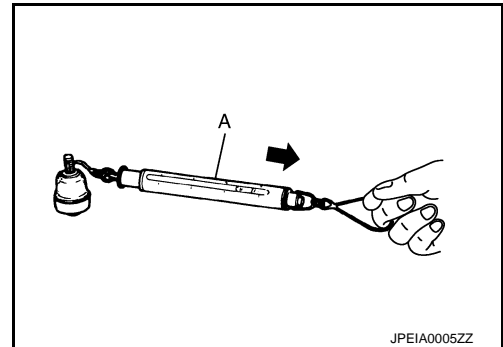

Rotating Torque Inspection

- Attach mounting nut to ball stud. Make sure that rotating torque is within specifications with a preload gauge (A) [SST: ST3127S000 (J-25765-A)].

Rotating torque : Refer to [FSU-20, "Ball Joint"](#).

- If rotating torque exceeds standard range, replace transverse link assembly.

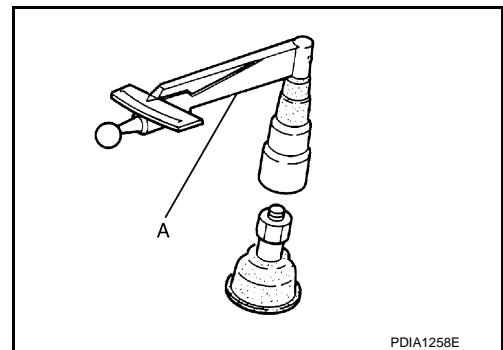

Axial End Play Inspection

- Move tip of ball stud in axial direction to check for looseness.

Axial end play : Refer to [FSU-20, "Ball Joint"](#).

- If axial end play exceeds standard range, replace transverse link assembly.

INSPECTION AFTER INSTALLATION

1. Check wheel sensor harness for proper connection. Refer to [BRC-150, "FRONT WHEEL SENSOR : Exploded View"](#).
2. Check wheel alignment. Refer to [FSU-8, "Inspection"](#).
3. Adjust neutral position of steering angle sensor. Refer to [BRC-10, "ADJUSTMENT OF STEERING ANGLE SENSOR NEUTRAL POSITION : Special Repair Requirement"](#).

UPPER LINK

< REMOVAL AND INSTALLATION >

[2WD]

UPPER LINK

Exploded View

INFOID:000000006566828

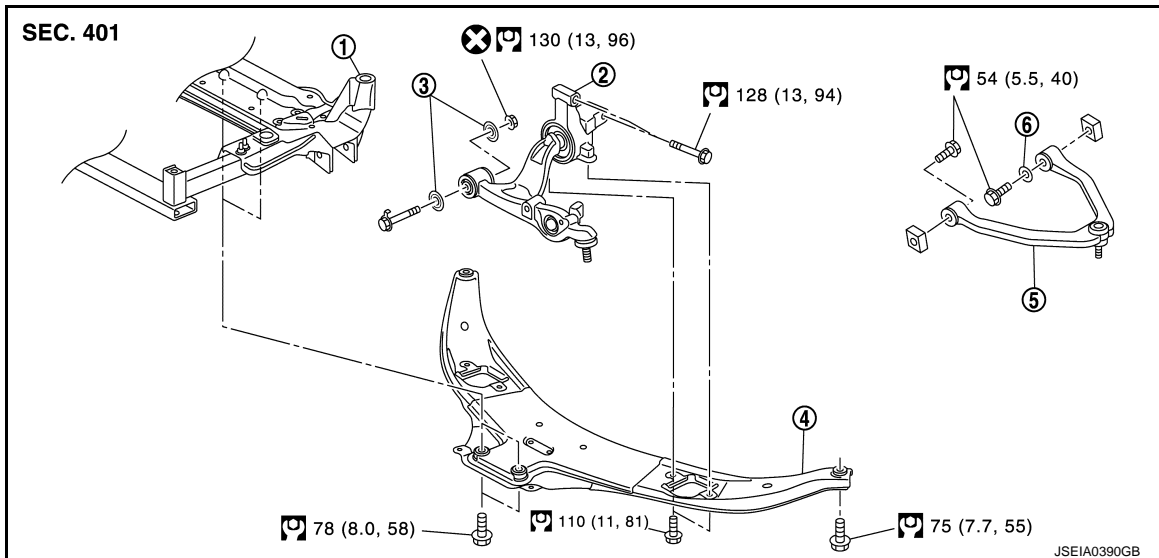

- | | | |
|----------------------------|--------------------|------------------------|
| 1. Front suspension member | 2. Transverse link | 3. Stopper bushing |
| 4. Front cross bar | 5. Upper link | 6. Stopper arm bushing |

Refer to [GI-4, "Components"](#) for symbols in the figure.

Removal and Installation

INFOID:000000006566829

REMOVAL

1. Remove tires with power tool.
2. Remove shock absorber. Refer to [FSU-10, "Exploded View"](#).
3. Remove upper link and stopper arm bushing.

INSTALLATION

Note the following, and install in the reverse order of removal.

- Perform final tightening of bolts and nuts at the vehicle installation position (rubber bushing), under unladen conditions with tires on level ground.

Inspection

INFOID:000000006566830

INSPECTION AFTER REMOVAL

Appearance

Check the following items, and replace the part if necessary.

- Upper link and bushing for deformation, cracks or damage.
- Ball joint boot for cracks or other damage, and also for grease leakage.

Ball Joint Inspection

Manually move ball stud to confirm it moves smoothly with no binding.

Swing Torque Inspection

NOTE:

Before measurement, move ball stud at least ten times by hand to check for smooth movement.

UPPER LINK

[2WD]

< REMOVAL AND INSTALLATION >

- Hook a spring balance (A) at cutout on ball stud. Confirm spring balance measurement value is within specifications when ball stud begins moving.

Swing torque : Refer to [FSU-20, "Ball Joint"](#).

- If swing torque exceeds standard range, replace upper link assembly.

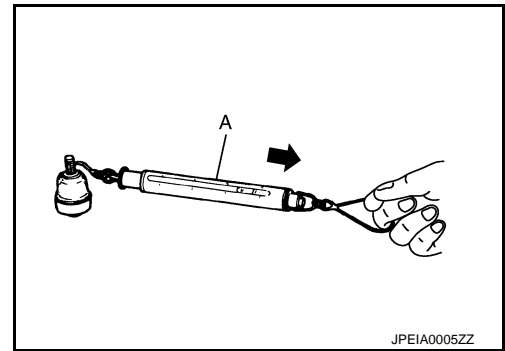

Axial End Play Inspection

- Move tip of ball stud in axial direction to check for looseness.

Axial end play : Refer to [FSU-20, "Ball Joint"](#).

- If axial end play exceeds standard range, replace upper link assembly.

INSPECTION AFTER INSTALLATION

1. Check wheel sensor harness for proper connection. Refer to [BRC-150, "FRONT WHEEL SENSOR : Exploded View"](#).
2. Check wheel alignment. Refer to [FSU-8, "Inspection"](#).
3. Adjust neutral position of steering angle sensor. Refer to [BRC-10, "ADJUSTMENT OF STEERING ANGLE SENSOR NEUTRAL POSITION : Special Repair Requirement"](#).

A
B
C
D
FSU
F
G
H
I
J
K
L
M
N
O
P

FRONT STABILIZER

< REMOVAL AND INSTALLATION >

[2WD]

FRONT STABILIZER

Exploded View

INFOID:000000006566831

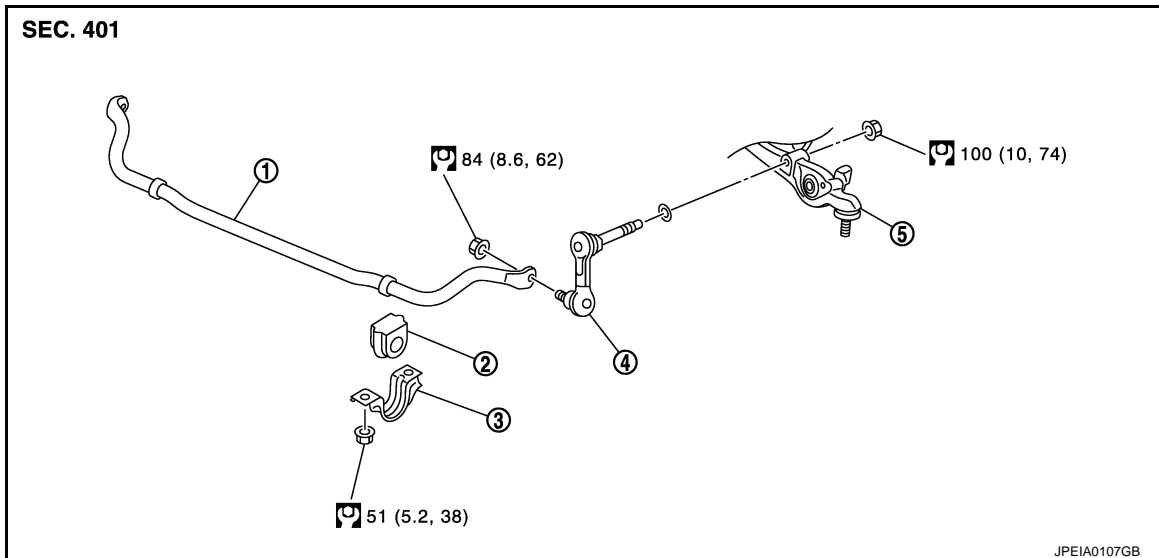

- | | | |
|------------------------------|-----------------------|---------------------|
| 1. Stabilizer bar | 2. Stabilizer bushing | 3. Stabilizer clamp |
| 4. Stabilizer connecting rod | 5. Transverse link | |

Refer to [GI-4, "Components"](#) for symbols in the figure.

Removal and Installation

INFOID:000000006566832

REMOVAL

1. Remove under cover with power tool.
2. Remove stabilizer connecting rod with power tool.
CAUTION:
Apply a matching mark to identify the installation position.
3. Remove stabilizer clamp and stabilizer bushing.
4. Remove stabilizer bar.

INSTALLATION

Note the following, and install in the reverse order of removal.

- Check the matching mark when installing.
- Tighten the mounting nut to the specified torque while holding a hexagonal part of stabilizer connecting rod side.

Inspection

INFOID:000000006566833

INSPECTION AFTER REMOVAL

Check stabilizer bar, stabilizer connecting rod, stabilizer bushing and stabilizer clamp for deformation, cracks or damage. Replace it if necessary.

FRONT SUSPENSION MEMBER

< UNIT REMOVAL AND INSTALLATION >

[2WD]

UNIT REMOVAL AND INSTALLATION

FRONT SUSPENSION MEMBER

Exploded View

INFOID:0000000006566834

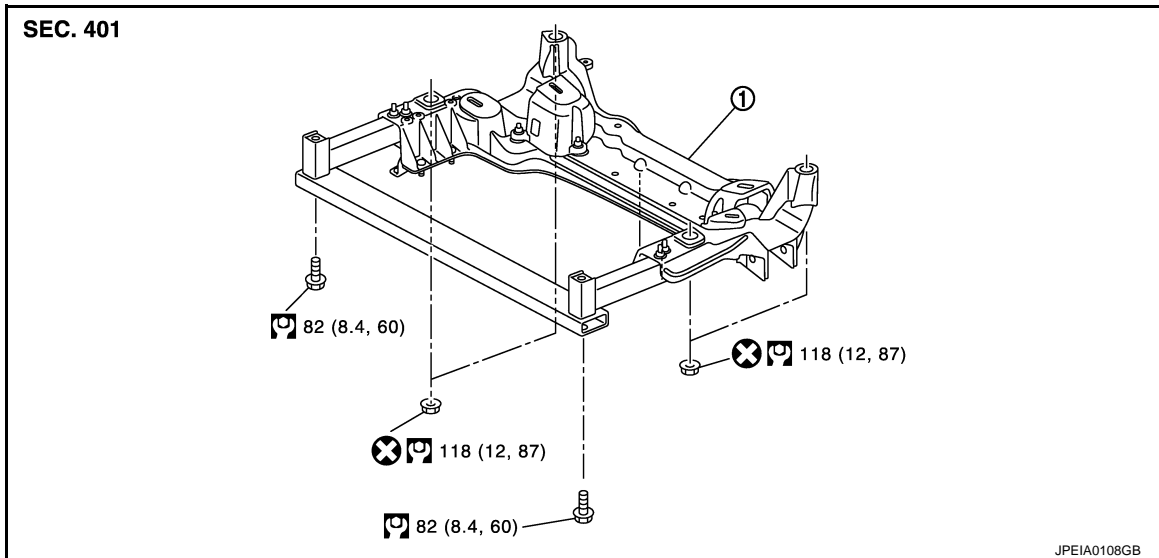

1. Front suspension member

Refer to [GI-4, "Components"](#) for symbols in the figure.

Removal and Installation

INFOID:0000000006566835

REMOVAL

1. Remove tires with power tool.
2. At first, remove the engine and the transmission assembly with front suspension member downward. Then separate the engine, transmission Refer to [EM-83, "2WD : Removal and Installation"](#).
3. Remove the following parts.
 - Steering knuckle and wheel hub and bearing assembly: refer to [FAX-6, "Exploded View"](#).
 - Steering gear assembly and hydraulic line: refer to [ST-26, "Exploded View"](#), [ST-48, "VQ35HR : Exploded View"](#).
 - Stabilizer bar and stabilizer connecting rod: refer to [FSU-18, "Exploded View"](#).
 - Transverse link: refer to [FSU-14, "Exploded View"](#).
 - Engine mount insulator: refer to [EM-83, "2WD : Exploded View"](#).

INSTALLATION

Note the following, and install in the reverse order of removal.

- Perform final tightening of bolts and nuts at the vehicle installation position (rubber bushing), under unladen condition with tires on level ground.

Inspection

INFOID:0000000006566836

INSPECTION AFTER REMOVAL

Check the front suspension member for significant deformation, cracks, or damages. Replace if necessary.

INSPECTION AFTER INSTALLATION

1. Check wheel sensor harness for proper connection. Refer to [BRC-150, "FRONT WHEEL SENSOR : Exploded View"](#).
2. Check wheel alignment. Refer to [FSU-8, "Inspection"](#).
3. Adjust the neutral position of the steering angle sensor. Refer to [BRC-10, "ADJUSTMENT OF STEERING ANGLE SENSOR NEUTRAL POSITION : Special Repair Requirement"](#).

SERVICE DATA AND SPECIFICATIONS (SDS)

< SERVICE DATA AND SPECIFICATIONS (SDS)

[2WD]

SERVICE DATA AND SPECIFICATIONS (SDS)

SERVICE DATA AND SPECIFICATIONS (SDS)

Wheel Alignment

INFOID:000000006566837

Item		Standard	
Camber Degree minute (Decimal degree)	Minimum	-1° 05' (-1.08°)	
	Nominal	-0° 20' (-0.33°)	
	Maximum	0° 25' (0.41°)	
	Left and right difference	0° 33' (0.55°) or less	
Caster Degree minute (Decimal degree)	Minimum	2° 55' (2.92°)	
	Nominal	3° 40' (3.67°)	
	Maximum	4° 25' (4.41°)	
	Left and right difference	0° 39' (0.65°) or less	
Kingpin inclination Degree minute (Decimal degree)	Minimum	7° 55' (7.92°)	
	Nominal	8° 40' (8.67°)	
	Maximum	9° 25' (9.41°)	
Toe-in	Total toe-in Distance	Minimum	In 1 mm (0.04 in)
		Nominal	In 2 mm (0.08 in)
		Maximum	In 3 mm (0.11 in)
	Toe angle (left wheel or right wheel) Degree minute (Decimal Degree)	Minimum	In 0° 02' 12" (0.04°)
		Nominal	In 0° 04' 24" (0.07°)
		Maximum	In 0° 06' 36" (0.11°)

Measure value under unladen* conditions.

*: Fuel, engine coolant and lubricant are full. Spare tire, jack, hand tools and mats are in designated positions.

Ball Joint

INFOID:000000006566838

Item		Standard
Swing torque	Transverse link	0.5 – 3.6 N·m (0.06 – 0.36 kg-m, 5 – 31 in-lb)
	Upper link	0 – 2.0 N·m (0 – 0.20 kg-m, 0 – 17 in-lb)
Measurement on spring balance	Transverse link	7.8 – 56.3 N (0.8 – 5.7 kg, 1.8 – 12.6 lb)
	Upper link	0 – 61.5 N (0 – 6.2 kg, 0 – 13.8 lb)
Rotating torque	Transverse link	0.5 – 3.9 N·m (0.06 – 0.39 kg-m, 5 – 34 in-lb)
Axial end play		0 mm (0 in)

SERVICE DATA AND SPECIFICATIONS (SDS)

< SERVICE DATA AND SPECIFICATIONS (SDS)

[2WD]

Wheel Height

INFOID:000000006566839

Tire size	265/60R18	265/50R20
Front (Hf)	831 mm (32.72 in)	832 mm (32.76 in)

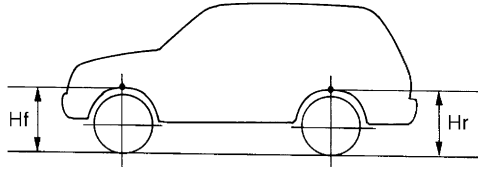

SFA746B

Measure value under unladen* conditions

*: Fuel, engine coolant and lubricant are full. Spare tire, jack, hand tools and mats are in designated positions.

A
B
C
D
F
G
H
I
J
K
L
M
N
O
P

FSU

NOISE, VIBRATION AND HARSHNESS (NVH) TROUBLESHOOTING

< SYMPTOM DIAGNOSIS >

[AWD]

SYMPTOM DIAGNOSIS

NOISE, VIBRATION AND HARSHNESS (NVH) TROUBLESHOOTING

NVH Troubleshooting Chart

INFOID:000000006566840

Use chart below to find the cause of the symptom. If necessary, repair or replace these parts.

Symptom		Possible cause and SUSPECTED PARTS														Reference				
Symptom	FRONT SUSPENSION	Noise	x	x	x	x	x	x			x	x	x	x	x	x	x	x	FSU-29, FSU-34, FSU-36, FSU-38, FSU-39	
		Shake	x	x	x	x		x			x									FSU-32
		Vibration	x	x	x	x	x					x								—
		Shimmy	x	x	x	x			x											—
		Judder	x	x	x															—
		Poor quality ride or handling	x	x	x	x	x		x	x										FSU-29, FSU-34, FSU-36, FSU-38, FSU-39
		Improper installation, looseness																	FSU-2Z	
		Shock absorber deformation, damage or deflection																	FSU-38	
		Bushing or mounting deterioration																		
		Parts interference																		
		Spring fatigue																		
		Suspension looseness																		
		Incorrect wheel alignment																		
		Stabilizer bar fatigue																		
		PROPELLER SHAFT																	NVH in DLN section.	
		DIFFERENTIAL																	NVH in DLN section.	
		FRONT AXLE AND FRONT SUSPENSION																	NVH in FAX and FSU sections.	
		TIRE																	NVH in WT section.	
		ROAD WHEEL																	NVH in WT section.	
		DRIVE SHAFT																	NVH in FAX section.	
		BRAKE																	NVH in BR section.	
		STEERING																	NVH in ST section.	

x: Applicable

PRECAUTION

PRECAUTIONS

Precaution for Supplemental Restraint System (SRS) "AIR BAG" and "SEAT BELT PRE-TENSIONER"

INFOID:000000006566841

The Supplemental Restraint System such as "AIR BAG" and "SEAT BELT PRE-TENSIONER", used along with a front seat belt, helps to reduce the risk or severity of injury to the driver and front passenger for certain types of collision. This system includes seat belt switch inputs and dual stage front air bag modules. The SRS system uses the seat belt switches to determine the front air bag deployment, and may only deploy one front air bag, depending on the severity of a collision and whether the front occupants are belted or unbelted. Information necessary to service the system safely is included in the "SRS AIR BAG" and "SEAT BELT" of this Service Manual.

WARNING:

Always observe the following items for preventing accidental activation.

- To avoid rendering the SRS inoperative, which could increase the risk of personal injury or death in the event of a collision that would result in air bag inflation, all maintenance must be performed by an authorized NISSAN/INFINITI dealer.
- Improper maintenance, including incorrect removal and installation of the SRS, can lead to personal injury caused by unintentional activation of the system. For removal of Spiral Cable and Air Bag Module, see "SRS AIR BAG".
- Never use electrical test equipment on any circuit related to the SRS unless instructed to in this Service Manual. SRS wiring harnesses can be identified by yellow and/or orange harnesses or harness connectors.

PRECAUTIONS WHEN USING POWER TOOLS (AIR OR ELECTRIC) AND HAMMERS

WARNING:

Always observe the following items for preventing accidental activation.

- When working near the Air Bag Diagnosis Sensor Unit or other Air Bag System sensors with the ignition ON or engine running, never use air or electric power tools or strike near the sensor(s) with a hammer. Heavy vibration could activate the sensor(s) and deploy the air bag(s), possibly causing serious injury.
- When using air or electric power tools or hammers, always switch the ignition OFF, disconnect the battery, and wait at least 3 minutes before performing any service.

Precautions Necessary for Steering Wheel Rotation After Battery Disconnection

INFOID:000000006566842

CAUTION:

Comply with the following cautions to prevent any error and malfunction.

- Before removing and installing any control units, first turn the ignition switch to the LOCK position, then disconnect both battery cables.
- After finishing work, confirm that all control unit connectors are connected properly, then re-connect both battery cables.
- Always use CONSULT to perform self-diagnosis as a part of each function inspection after finishing work. If a DTC is detected, perform trouble diagnosis according to self-diagnosis results.

For vehicle with steering lock unit, if the battery is disconnected or discharged, the steering wheel will lock and cannot be turned.

If turning the steering wheel is required with the battery disconnected or discharged, follow the operation procedure below before starting the repair operation.

OPERATION PROCEDURE

1. Connect both battery cables.

NOTE:

Supply power using jumper cables if battery is discharged.

2. Turn the ignition switch to ACC position.
(At this time, the steering lock will be released.)
3. Disconnect both battery cables. The steering lock will remain released with both battery cables disconnected and the steering wheel can be turned.

A
B
C
D
FSU
F
G
H
I
J
K
L
M
N
O
P

PRECAUTIONS

[AWD]

< PRECAUTION >

4. Perform the necessary repair operation.
5. When the repair work is completed, re-connect both battery cables. With the brake pedal released, turn the ignition switch from ACC position to ON position, then to LOCK position. (The steering wheel will lock when the ignition switch is turned to LOCK position.)
6. Perform self-diagnosis check of all control units using CONSULT.

Precaution for Procedure without Cowl Top Cover

INFOID:000000006566843

When performing the procedure after removing cowl top cover, cover the lower end of windshield with urethane, etc to prevent damage to windshield.

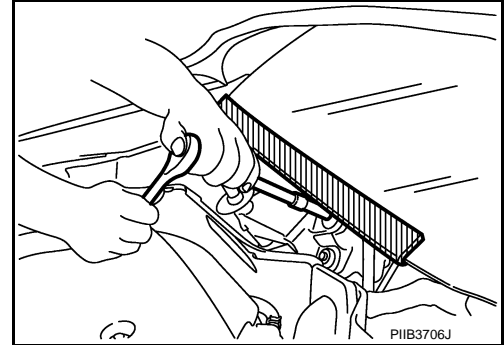

Precautions for Suspension

INFOID:000000006566844

CAUTION:

- When installing rubber bushings, the final tightening must be carried out under unladen conditions with tires on ground. Spilled oil might shorten the life of rubber bushings. Be sure to wipe off any spilled oil.
- Unladen conditions mean that fuel, engine coolant and lubricant are full. Spare tire, jack, hand tools and mats are in designated positions.
- After servicing suspension parts, be sure to check wheel alignment.
- Self-lock nuts are not reusable. Always use new ones when installing. Since new self-lock nuts are pre-oiled, tighten as they are.

PREPARATION

< PREPARATION >

[AWD]

PREPARATION

PREPARATION

Special Service Tool

INFOID:0000000006566845

The actual shapes of Kent-Moore tools may differ from those of special service tools illustrated here.

Tool number (Kent-Moore No.) Tool name	Description
ST35652000 (-) Shock absorber attachment	Disassembling and assembling shock absorber
ST3127S000 (J-25765-A) Preload gauge	Measuring rotating torque of ball joint

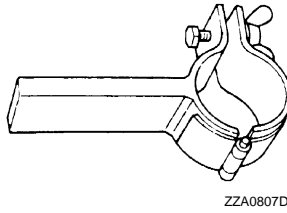

ZZA0807D

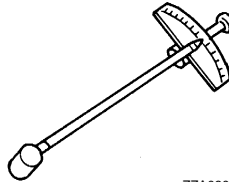

ZZA0806D

Commercial Service Tool

INFOID:0000000006566846

Tool name	Description
Power tool	Loosening bolts and nuts
Spring compressor	Removing and installing coil spring

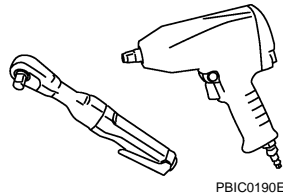

PBIC0190E

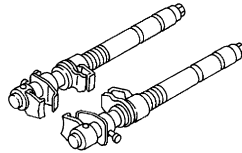

S-NT717

FRONT SUSPENSION ASSEMBLY

< PERIODIC MAINTENANCE >

[AWD]

PERIODIC MAINTENANCE

FRONT SUSPENSION ASSEMBLY

Inspection

INFOID:000000006566847

COMPONENT PART

Check the mounting conditions (looseness, backlash) of each component and component conditions (wear, damage) are normal.

Ball Joint Axial End Play

1. Set front wheels in a straight-ahead position.
2. Move axle side of transverse link and upper link in the axial direction by hand. Check there is no end play.

Axial end play : Refer to [FSU-41, "Ball Joint"](#).

CAUTION:

- Never depress brake pedal when measuring.
- Never perform with tires on level ground.
- Be careful not to damage ball joint boot. Never damage the installation position by applying excessive force.

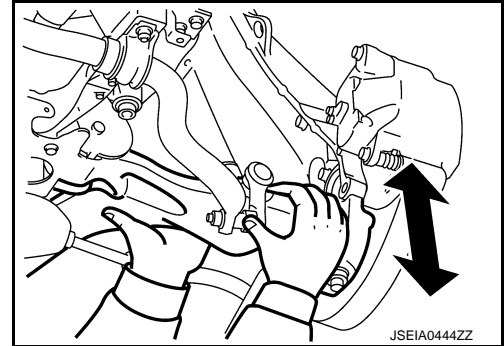

SHOCK ABSORBER

Check for oil leakage, damage. Replace it if necessary.

WHEEL ALIGNMENT

< PERIODIC MAINTENANCE >

[AWD]

WHEEL ALIGNMENT

Inspection

INFOID:000000006566848

DESCRIPTION

CAUTION:

- **Camber, caster, kingpin inclination angles cannot be adjusted.**
- **If camber, caster, or kingpin inclination angle is outside the standard, check front suspension parts for wear and damage. Replace suspect parts if a malfunction is detected.**
- **Kingpin inclination angle is reference value, no inspection is required.**
- Measure wheel alignment under unladen conditions.

NOTE:

“Unladen conditions” means that fuel, engine coolant, and lubricant are full. Spare tire, jack, hand tools and mats are in designated positions.

PRELIMINARY CHECK

Check the following:

- Tires for improper air pressure and wear. Refer to [WT-85, "Tire Air Pressure"](#).
- Road wheels for runout.
- Wheel bearing axial end play. Refer to [FAX-14, "Inspection"](#).
- Transverse link or upper link ball joint axial end play.
- Shock absorber operation.
- Each mounting part of axle and suspension for looseness and deformation.
- Each of suspension member, shock absorber, upper link and transverse link for cracks, deformation and other damage.
- Vehicle height (posture).

GENERAL INFORMATION AND RECOMMENDATIONS

- A four-wheel thrust alignment should be performed.
- This type of alignment is recommended for any NISSAN/INFINITI vehicle.
- The four-wheel “thrust” process helps ensure that the vehicle is properly aligned and the steering wheel is centered.
- The alignment rack itself should be capable of accepting any NISSAN/INFINITI vehicle.
- The rack should be checked to ensure that it is level.
- Make sure the machine is properly calibrated.
- Your alignment equipment should be regularly calibrated in order to give correct information.
- Check with the manufacturer of your specific equipment for their recommended Service/Calibration Schedule.

ALIGNMENT PROCESS

IMPORTANT:

Use only the alignment specifications listed in this Service Manual.

- When displaying the alignment settings, many alignment machines use “indicators”: (Green/red, plus or minus, Go/No Go). **Do not use these indicators.**
- The alignment specifications programmed into your machine that operate these indicators may not be correct.
- This may result in an ERROR.
- Most camera-type alignment machines are equipped with both “Rolling Compensation” method and optional “Jacking Compensation” method to “compensate” the alignment targets or head units. “Rolling Compensation” is the preferred method.
- If using the “Rolling Compensation” method, after installing the alignment targets or head units, push or pull on the rear wheel to move the vehicle. **Do not push or pull on the vehicle body.**
- If using the “Jacking Compensation” method, after installing the alignment targets or head units, raise the vehicle and rotate the wheels 1/2 turn both ways.

NOTE:

- Do not use the “Rolling Compensation” method if you are using sensor-type alignment equipment.
- Follow all instructions for the alignment machine you're using for more information.

Adjustment

INFOID:000000008145955

TOE-IN

WHEEL ALIGNMENT

< PERIODIC MAINTENANCE >

[AWD]

- Loosen the steering outer socket, and then adjust the length using steering inner socket.

Toe-in : Refer to [FSU-41, "Wheel Alignment"](#).

CAUTION:

- Always evenly adjust both toe-in alternately and adjust the difference between the left and right to the standard.
- Always fix the steering inner socket when tightening the steering outer socket.
- After toe-in adjustment, adjust neutral position of steering angle sensor. Refer to [BRC-10, "ADJUSTMENT OF STEERING ANGLE SENSOR NEUTRAL POSITION : Special Repair Requirement"](#).

FRONT COIL SPRING AND SHOCK ABSORBER

< REMOVAL AND INSTALLATION >

[AWD]

REMOVAL AND INSTALLATION

FRONT COIL SPRING AND SHOCK ABSORBER

Exploded View

INFOID:000000006566849

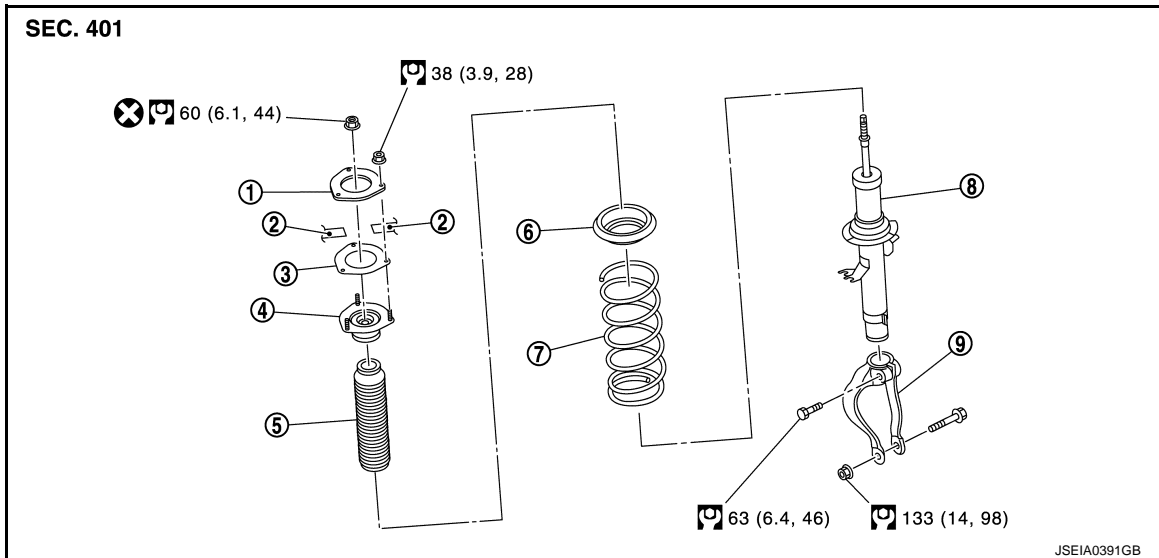

- | | | |
|------------------------------------|-------------------|-----------------------|
| 1. Gusset | 2. Vehicle body | 3. Mounting seal |
| 4. Shock absorber mounting bracket | 5. Bound bumper | 6. Rubber seat |
| 7. Coil spring | 8. Shock absorber | 9. Shock absorber arm |

Refer to [GI-4, "Components"](#) for symbols in the figure.

Removal and Installation

INFOID:000000006566850

REMOVAL

1. Remove engine cover. Refer to [EM-27, "Exploded View"](#) (VQ35HR), [EM-177, "Exploded View"](#) (VK50VE).
2. Remove front fender protector. Refer to [EXT-25, "FENDER PROTECTOR : Exploded View"](#).
3. Remove tires with power tool.
4. Remove wheel sensor and harness connector from vehicle. Refer to [BRC-150, "FRONT WHEEL SENSOR : Exploded View"](#).

CAUTION:

Never pull on wheel sensor harness.

5. Remove shock absorber actuator harness connector (with Continuous Damping Control).
6. Remove front wheel vertical G sensor (with Continuous Damping Control). Refer to [SCS-69, "Exploded View"](#).
7. Remove brake hose bracket. Refer to [BR-20, "FRONT : Exploded View"](#).
8. Remove stabilizer connecting rod with power tool. Refer to [FSU-38, "Exploded View"](#).
9. Remove wheel hub lock nut. Refer to [FAX-16, "Exploded View"](#).
10. Remove shock absorber from transverse link with power tool.
11. Separate upper link from steering knuckle. Refer to [FAX-16, "Exploded View"](#).
12. Separate drive shaft from wheel hub and bearing assembly.
13. Remove shock absorber assembly.

NOTE:

If removing shock absorber is difficult, loosen upper link mounting bolts (vehicle side).

INSTALLATION

Note the following, and install in the reverse order of removal.

FRONT COIL SPRING AND SHOCK ABSORBER

[AWD]

< REMOVAL AND INSTALLATION >

- Never tap on the ball joint cap of the stabilizer connecting rod with a hammer or a similar item when inserting the stabilizer connecting rod into the transverse link.
- Perform final tightening of bolts and nuts at the shock absorber lower side (rubber bushing), under unladen conditions with tires on level ground.

Disassembly and Assembly

INFOID:000000006566851

DISASSEMBLY

CAUTION:

Never damage shock absorber piston rod when removing components from shock absorber.

1. Remove shock absorber arm.
2. Install shock absorber attachment (A) [SST: ST35652000 (-)] to shock absorber and secure it in a vise.

CAUTION:

When installing the shock absorber attachment to shock absorber, wrap a shop cloth around shock absorber to protect it from damage.

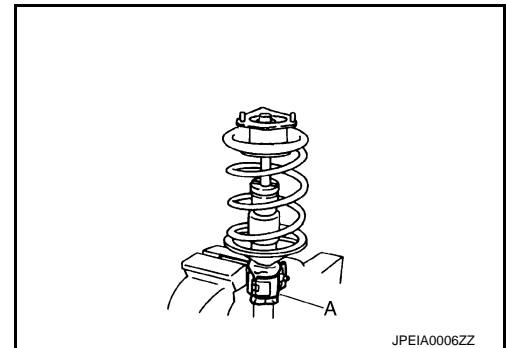

JPEIA0006ZZ

3. Using a spring compressor (A) (commercial service tool), compress coil spring between rubber seat and shock absorber until coil spring with a spring compressor is free.

CAUTION:

Be sure a spring compressor is securely attached coil spring. Compress coil spring

4. Make sure coil spring with a spring compressor between rubber seat and shock absorber is free. And then remove piston rod lock nut while securing the piston rod tip so that piston rod does not turn.
5. Remove mounting seal, shock absorber mounting bracket, rubber seat, bound bumper from shock absorber.
6. After removing coil spring with a spring compressor, then gradually release a spring compressor.

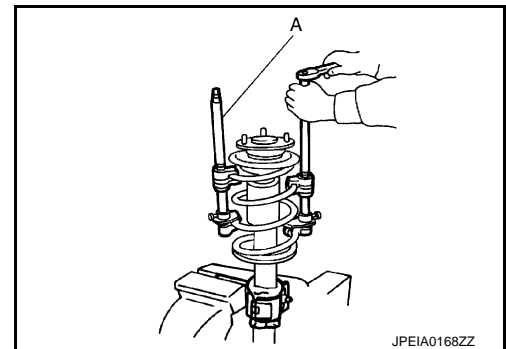

JPEIA0168ZZ

CAUTION:

Loosen while making sure coil spring attachment position does not move.

7. Remove the shock absorber attachment from shock absorber.

ASSEMBLY

1. Install shock absorber attachment (A) [SST: ST35652000 (-)] to shock absorber and secure it in a vise.

CAUTION:

When installing the shock absorber attachment to shock absorber, wrap a shop cloth around shock absorber to protect it from damage.

2. Compress coil spring using a spring compressor (commercial service tool), and install it onto shock absorber.

CAUTION:

FRONT COIL SPRING AND SHOCK ABSORBER

[AWD]

< REMOVAL AND INSTALLATION >

- Install with the large-diameter side (A) facing up and the small-diameter side (B) facing down.
- Be sure a spring compressor is securely attached to coil spring. Compress coil spring.

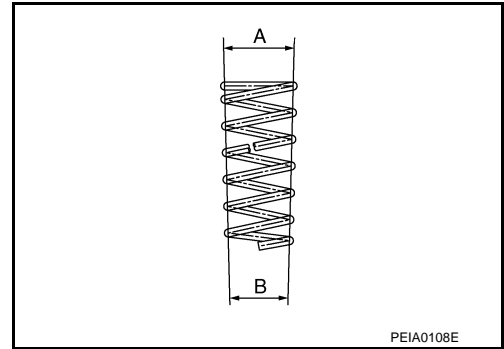

3. Install the shock absorber mounting bracket and rubber seat.
CAUTION:
Align the paint mark (A) to the stud bolt (1) position when assembling.
4. Apply soapy water to bound bumper.
CAUTION:
Never use machine oil.

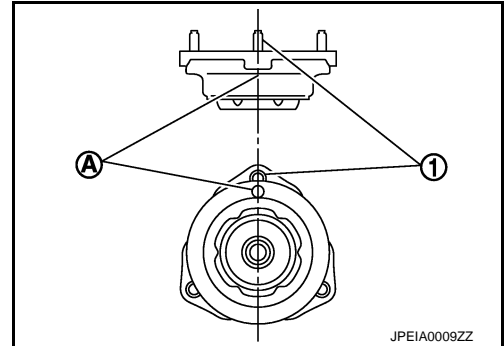

5. Insert bound bumper into shock absorber mounting bracket, and then install it to shock absorber together with rubber seat.

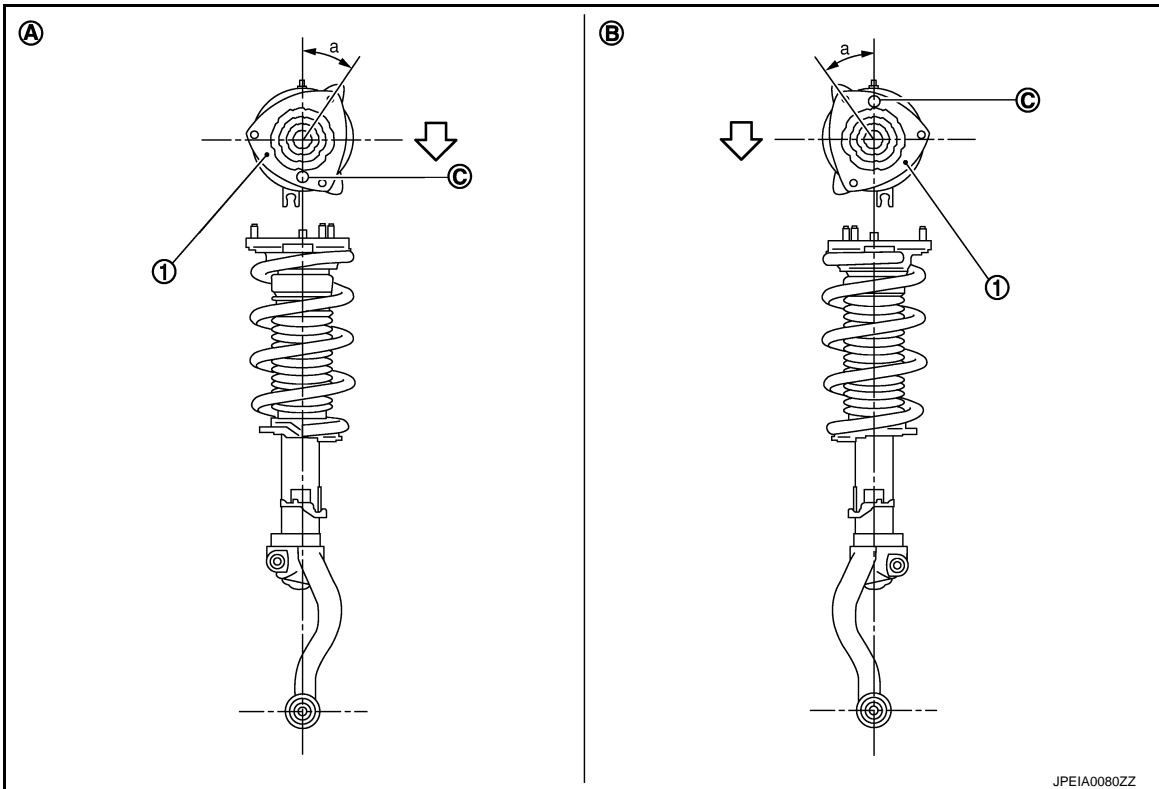

1. Shock absorber mounting bracket

A. Right side

B. Left side

C. Coil spring lower end position

↔ : Vehicle front

- Install the shock absorber mounting bracket as shown in the figure.

FRONT COIL SPRING AND SHOCK ABSORBER

< REMOVAL AND INSTALLATION >

[AWD]

Angle (a) : 30.0°

- Check that the lower end of the coil spring (C) is positioned at the spring lower seat of the shock absorber.
- Secure piston rod tip so that piston rod does not turn, then tighten piston rod lock nut to the specified torque.
 - Gradually release a spring compressor, and remove coil spring.
CAUTION:
Loosen while making sure coil spring attachment position does not move.
 - Remove the shock absorber attachment from shock absorber.
 - Install the shock absorber arm to shock absorber.
CAUTION:
To install, align the shock absorber protrusion (A) with the groove of shock absorber arm (1) and press it all the way to the locating bracket (B).
 - Install the mounting seal to shock absorber mounting bracket.

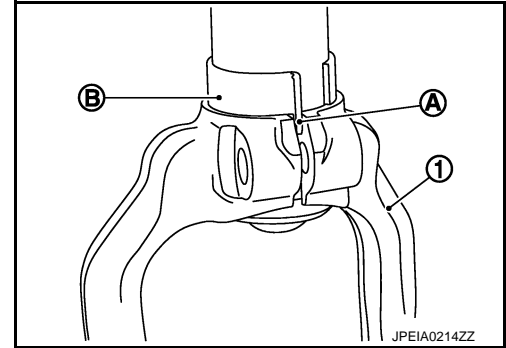

INFOID:000000006566852

Inspection

INSPECTION AFTER INSTALLATION

- Check shock absorber actuator harness connector for proper connection (with Continuous Damping Control).
- Check wheel sensor harness for proper connection. Refer to [BRC-150, "FRONT WHEEL SENSOR : Exploded View"](#).
- Check wheel alignment. Refer to [FSU-27, "Inspection"](#).
- Adjust neutral position of steering angle sensor. Refer to [BRC-10, "ADJUSTMENT OF STEERING ANGLE SENSOR NEUTRAL POSITION : Special Repair Requirement"](#).

INSPECTION AFTER DISASSEMBLY

Shock Absorber

Check the following items, and replace the part if necessary.

- Shock absorber for deformation, cracks or damage.
- Piston rod for damage, uneven wear or distortion.
- Oil leakage.

Shock Absorber Mounting Bracket and Rubber Parts Inspection

Check shock absorber mounting bracket for cracks and rubber parts for wear. Replace it if necessary

Coil Spring

Check coil spring for cracks, wear or damage. Replace it if necessary.

Disposal

INFOID:000000006566853

- Set shock absorber horizontally with the piston rod fully extended.

FRONT COIL SPRING AND SHOCK ABSORBER

< REMOVAL AND INSTALLATION >

[AWD]

2. Drill 2 – 3 mm (0.08 – 0.12 in) hole at the position (●) from top as shown in the figure to release gas gradually.

CAUTION:

- **Wear eye protection (safety glasses).**
- **Wear gloves.**
- **Be careful with metal chips or oil blown out by the compressed gas.**

NOTE:

- Drill vertically in this direction (←).
- Directly to the outer tube avoiding brackets.
- The gas is clear, colorless, odorless, and harmless.

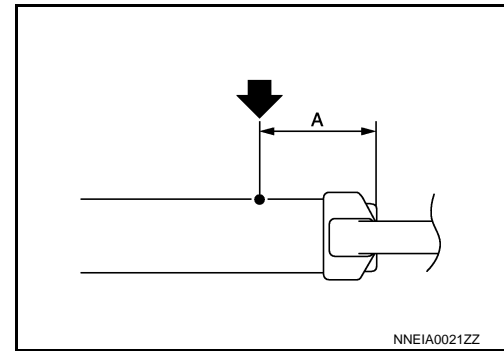

A : 20 – 30 mm (0.79 – 1.18 in)

3. Position the drilled hole downward and drain oil by moving the piston rod several times.

CAUTION:

Dispose of drained oil according to the law and local regulations.

A
B
C
D

FSU

F
G
H
I
J
K
L
M
N
O
P

TRANSVERSE LINK

< REMOVAL AND INSTALLATION >

[AWD]

TRANSVERSE LINK

Exploded View

INFOID:000000006566854

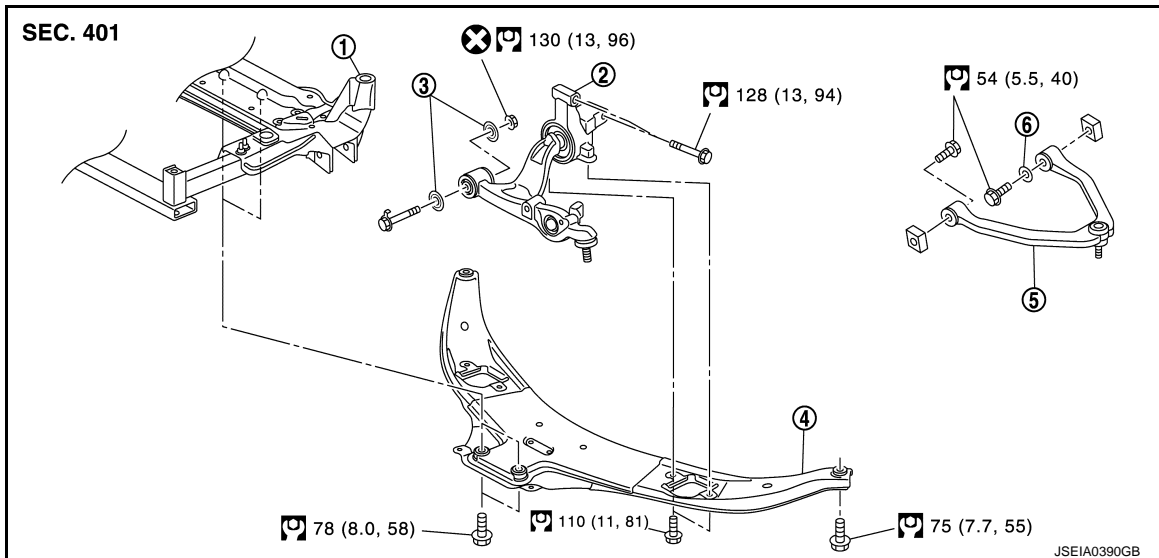

- | | | |
|----------------------------|--------------------|------------------------|
| 1. Front suspension member | 2. Transverse link | 3. Stopper bushing |
| 4. Front cross bar | 5. Upper link | 6. Stopper arm bushing |

Refer to [GI-4, "Components"](#) for symbols in the figure.

Removal and Installation

INFOID:000000006566855

REMOVAL

1. Remove tires with power tool.
2. Remove shock absorber. Refer to [FSU-29, "Exploded View"](#).
3. Temporarily install upper link and steering knuckle. Refer to [FAX-16, "Exploded View"](#).
4. Remove front cross bar.
5. Remove transverse link from steering knuckle.
6. Set suitable jack under transverse link.
7. Remove transverse link and stopper bushings.

NOTE:

If removing transverse link mounting bolt (front side) is difficult, rotating steering wheel and remove steering outer socket. Refer to [ST-26, "Exploded View"](#).

INSTALLATION

Note the following, and install in the reverse order of removal.

- Never tap on the ball joint cap of the stabilizer connecting rod with a hammer or a similar item when inserting the stabilizer connecting rod into the transverse link.
- Perform final tightening of bolts and nuts at the front suspension member installation and shock absorber lower side (rubber bushing), under unladen conditions with tires on level ground.

Inspection

INFOID:000000006566856

INSPECTION AFTER REMOVAL

Appearance

Check the following items, and replace the part if necessary.

- Transverse link and bushing for deformation, cracks or damage.
- Ball joint boot for cracks or other damage, and also for grease leakage.

Ball Joint Inspection

TRANSVERSE LINK

[AWD]

< REMOVAL AND INSTALLATION >

Manually move ball stud to confirm it moves smoothly with no binding.

Swing Torque Inspection

NOTE:

Before measurement, move ball stud at least ten times by hand to check for smooth movement.

- Hook a spring balance (A) at cotter pin mounting hole. Confirm spring balance measurement value is within specifications when ball stud begins moving.

Swing torque : Refer to [FSU-41, "Ball Joint"](#).

- If swing torque exceeds standard range, replace transverse link assembly.

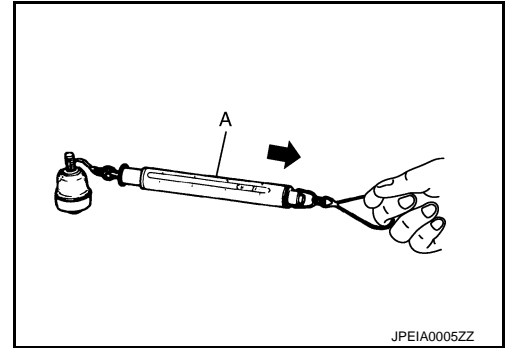

Rotating Torque Inspection

- Attach mounting nut to ball stud. Make sure that rotating torque is within specifications with a preload gauge (A) [SST: 3127S000 (J-25765-A)].

Rotating torque : Refer to [FSU-41, "Ball Joint"](#).

- If rotating torque exceeds standard range, replace transverse link assembly.

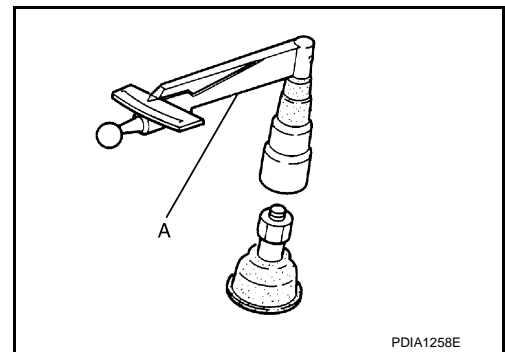

Axial End Play Inspection

- Move tip of ball stud in axial direction to check for looseness.

Axial end play : Refer to [FSU-41, "Ball Joint"](#).

- If axial end play exceeds standard range, replace transverse link assembly.

INSPECTION AFTER INSTALLATION

1. Check shock absorber actuator harness connector for proper connection (with Continuous Damping Control).
2. Check wheel sensor harness for proper connection. Refer to [BRC-150, "FRONT WHEEL SENSOR : Exploded View"](#).
3. Check wheel alignment. Refer to [FSU-27, "Inspection"](#).
4. Adjust neutral position of steering angle sensor. Refer to [BRC-10, "ADJUSTMENT OF STEERING ANGLE SENSOR NEUTRAL POSITION : Special Repair Requirement"](#).

UPPER LINK

< REMOVAL AND INSTALLATION >

[AWD]

UPPER LINK

Exploded View

INFOID:000000006566857

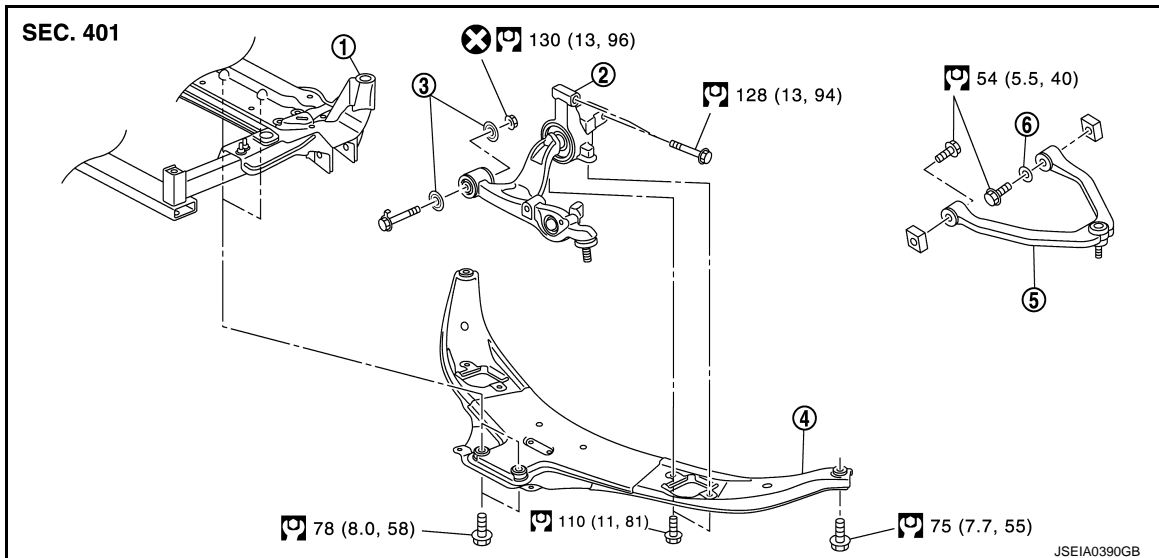

- | | | |
|----------------------------|--------------------|------------------------|
| 1. Front suspension member | 2. Transverse link | 3. Stopper bushing |
| 4. Front cross bar | 5. Upper link | 6. Stopper arm bushing |

Refer to [GI-4, "Components"](#) for symbols in the figure.

Removal and Installation

INFOID:000000006566858

REMOVAL

1. Remove tires from with power tool.
2. Remove shock absorber. Refer to [FSU-29, "Exploded View"](#).
3. Remove upper link and stopper arm bushing.

INSTALLATION

Note the following, and install in the reverse order of removal.

- Perform final tightening of bolts and nuts at the vehicle installation position (rubber bushing), under unladen conditions with tires on level ground.

Inspection

INFOID:000000006566859

INSPECTION AFTER REMOVAL

Appearance

Check the following items, and replace the part if necessary.

- Upper link and bushing for deformation, cracks or damage.
- Ball joint boot for cracks or other damage, and also for grease leakage.

Ball Joint Inspection

Manually move ball stud to confirm it moves smoothly with no binding.

Swing Torque Inspection

NOTE:

Before measurement, move ball stud at least ten times by hand to check for smooth movement.

UPPER LINK

< REMOVAL AND INSTALLATION >

[AWD]

- Hook a spring balance (A) at cutout on ball stud. Confirm spring balance measurement value is within specifications when ball stud begins moving.

Swing torque : Refer to [FSU-41, "Ball Joint"](#).

- If swing torque exceeds standard range, replace upper link assembly.

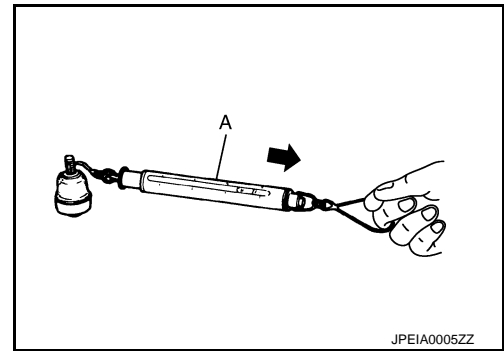

Axial End Play Inspection

- Move tip of ball stud in axial direction to check for looseness.

Axial end play : Refer to [FSU-41, "Ball Joint"](#).

- If axial end play exceeds standard range, replace upper link assembly.

INSPECTION AFTER INSTALLATION

1. Check shock absorber actuator harness connector for proper connection (with Continuous Damping Control).
2. Check wheel sensor harness for proper connection. Refer to [BRC-150, "FRONT WHEEL SENSOR : Exploded View"](#).
3. Check wheel alignment. Refer to [FSU-27, "Inspection"](#).
4. Adjust neutral position of steering angle sensor. Refer to [BRC-10, "ADJUSTMENT OF STEERING ANGLE SENSOR NEUTRAL POSITION : Special Repair Requirement"](#).

A
B
C
D

FSU

F
G
H
I
J
K
L
M
N
O
P

FRONT STABILIZER

< REMOVAL AND INSTALLATION >

[AWD]

FRONT STABILIZER

Exploded View

INFOID:000000006566860

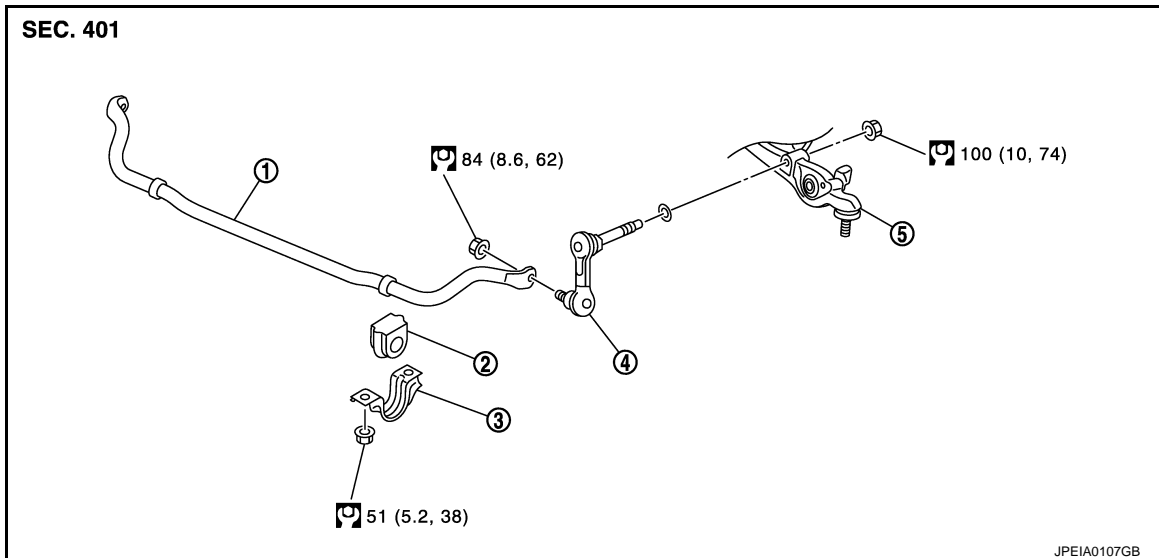

- | | | |
|------------------------------|-----------------------|---------------------|
| 1. Stabilizer bar | 2. Stabilizer bushing | 3. Stabilizer clamp |
| 4. Stabilizer connecting rod | 5. Transverse link | |

Refer to [GI-4, "Components"](#) for symbols in the figure.

Removal and Installation

INFOID:000000006566861

REMOVAL

1. Remove under cover.
2. Remove stabilizer connecting rod with power tool.
CAUTION:
Apply a matching mark to identify the installation position.
3. Remove stabilizer clamp and stabilizer bushing.
4. Remove stabilizer bar.

INSTALLATION

Note the following, and install in the reverse order of removal.

- Check the matching mark when installing.
- Tighten the mounting nut to the specified torque while holding a hexagonal part of stabilizer connecting rod side.

Inspection

INFOID:000000006566862

INSPECTION AFTER REMOVAL

Check stabilizer bar, stabilizer connecting rod, stabilizer bushing and stabilizer clamp for deformation, cracks or damage. Replace it if necessary.

FRONT SUSPENSION MEMBER

< UNIT REMOVAL AND INSTALLATION >

[AWD]

UNIT REMOVAL AND INSTALLATION

FRONT SUSPENSION MEMBER

Exploded View

INFOID:0000000006566863

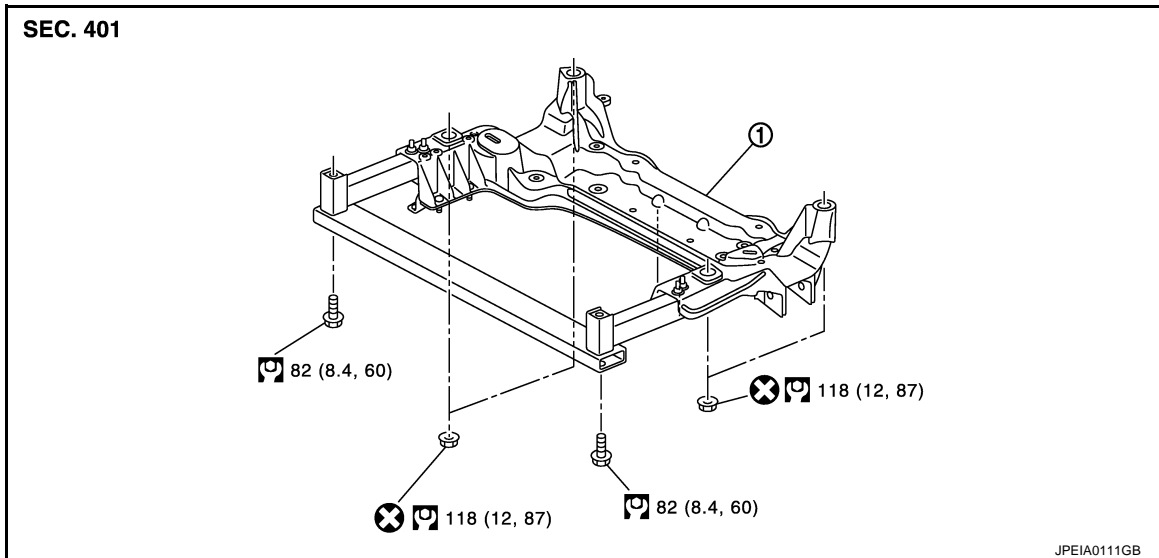

1. Front suspension member

Refer to [GI-4, "Components"](#) for symbols in the figure.

Removal and Installation

INFOID:0000000006566864

REMOVAL

1. Remove tire with power tool.
2. At first, remove the following parts as a set.
 - Engine, transmission assembly, transfer and front final drive: refer to [EM-88, "AWD : Removal and Installation"](#) (VQ35HR), [EM-200, "Removal and Installation"](#) (VK50VE).
 - Drive shaft: refer to [FAX-26, "Exploded View"](#).
3. Remove the following parts.
 - Steering knuckle and wheel hub and bearing assembly: refer to [FAX-16, "Exploded View"](#).
 - Steering gear assembly and hydraulic line: refer to [ST-26, "Exploded View"](#), [ST-48, "VQ35HR : Exploded View"](#) (VQ35HR), [ST-49, "VK50VE : Exploded View"](#) (VK50VE).
 - Stabilizer bar and stabilizer connecting rod: refer to [FSU-38, "Exploded View"](#).
 - Transverse link: refer to [FSU-34, "Exploded View"](#).
 - Engine mount insulator: refer to [EM-88, "AWD : Exploded View"](#) (VQ35HR), [EM-200, "Exploded View"](#) (VK50VE).

INSTALLATION

Note the following, and install in the reverse order of removal.

- Perform final tightening of bolts and nut at the vehicle installation position (rubber bushing), under unladen condition with tires on level ground.

Inspection

INFOID:0000000006566865

INSPECTION AFTER REMOVAL

Check the front suspension member for significant deformation, cracks, or damages. Replace if necessary.

INSPECTION AFTER INSTALLATION

1. Check shock absorber actuator harness connector for proper connection (with Continuous Damping Control).

FRONT SUSPENSION MEMBER

< UNIT REMOVAL AND INSTALLATION >

[AWD]

2. Check wheel sensor harness for proper connection. Refer to [BRC-150. "FRONT WHEEL SENSOR : Exploded View"](#).
3. Check wheel alignment. Refer to [FSU-27. "Inspection"](#).
4. Adjust the neutral position of the steering angle sensor. Refer to [BRC-10. "ADJUSTMENT OF STEERING ANGLE SENSOR NEUTRAL POSITION : Special Repair Requirement"](#).

SERVICE DATA AND SPECIFICATIONS (SDS)

< SERVICE DATA AND SPECIFICATIONS (SDS)

[AWD]

SERVICE DATA AND SPECIFICATIONS (SDS)

SERVICE DATA AND SPECIFICATIONS (SDS)

Wheel Alignment

INFOID:0000000006566866

Item		Standard	
Camber Degree minute (Decimal degree)	Minimum	-1° 05' (-1.08°)	
	Nominal	-0° 20' (-0.33°)	
	Maximum	0° 25' (0.41°)	
	Left and right difference	0° 33' (0.55°) or less	
Caster Degree minute (Decimal degree)	Minimum	2° 55' (2.92°)	
	Nominal	3° 40' (3.67°)	
	Maximum	4° 25' (4.41°)	
	Left and right difference	0° 39' (0.65°) or less	
Kingpin inclination Degree minute (Decimal degree)	Minimum	7° 55' (7.92°)	
	Nominal	8°40' (8.67°)	
	Maximum	9° 25' (9.41°)	
Toe-in	Total toe-in Distance	Minimum	In 1 mm (0.04 in)
		Nominal	In 2 mm (0.08 in)
		Maximum	In 3 mm (0.11 in)
	Toe angle (left wheel or right wheel) Degree minute (Decimal Degree)	Minimum	In 0° 02' 12" (0.04°)
		Nominal	In 0° 04' 24" (0.07°)
		Maximum	In 0° 06' 36" (0.11°)

Measure value under unladen* conditions.

*: Fuel, engine coolant and lubricant are full. Spare tire, jack, hand tools and mats are in designated positions.

Ball Joint

INFOID:0000000006566867

Item		Standard
Swing torque	Transverse link	0.5 – 3.6 N·m (0.06 – 0.36 kg-m, 5 – 31 in-lb)
	Upper link	0 – 2.0 N·m (0 – 0.20 kg-m, 0 – 17 in-lb)
Measurement on spring balance	Transverse link	7.8 – 56.3 N (0.8 – 5.7 kg, 1.8 – 12.6 lb)
	Upper link	0 – 61.5 N (0 – 6.2 kg, 0 – 13.8 lb)
Rotating torque	Transverse link	0.5 – 3.9 N·m (0.06 – 0.39 kg-m, 5 – 34 in-lb)
Axial end play		0 mm (0 in)

SERVICE DATA AND SPECIFICATIONS (SDS)

< SERVICE DATA AND SPECIFICATIONS (SDS)

[AWD]

Wheel Height

INFOID:000000006566868

Tire size	265/60R18	265/50R20	265/45R21
Front (Hf)	830 mm (32.68 in)		831 mm (32.72 in)

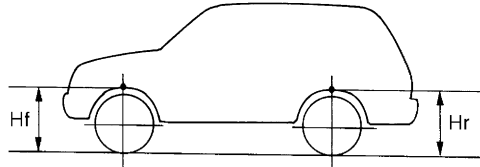

SFA746B

Measure value under unladen* conditions.

*: Fuel, engine coolant and lubricant are full. Spare tire, jack, hand tools and mats are in designated positions.