

SECTION **IP**
INSTRUMENT PANEL

A
B
C
D
E
F
G
H
I
IP
K
L
M
N
O
P

CONTENTS

PRECAUTION	2	SYMPTOM DIAGNOSIS	6
PRECAUTIONS	2	SQUEAK AND RATTLE TROUBLE DIAG- NOSES	6
Precaution for Supplemental Restraint System (SRS) "AIR BAG" and "SEAT BELT PRE-TEN- SIONER"	2	Work Flow	6
Precautions Necessary for Steering Wheel Rota- tion After Battery Disconnection	2	Inspection Procedure	8
Precaution	3	Diagnostic Worksheet	10
PREPARATION	4	REMOVAL AND INSTALLATION	12
PREPARATION	4	INSTRUMENT PANEL ASSEMBLY	12
Special Service Tools	4	Exploded View	12
Commercial Service Tools	4	Removal and Installation	13
CLIP LIST	5	CENTER CONSOLE ASSEMBLY	23
Clip List	5	Exploded View	23
		Removal and Installation	23
		Disassembly and Assembly	25

PRECAUTIONS

< PRECAUTION >

PRECAUTION

PRECAUTIONS

Precaution for Supplemental Restraint System (SRS) "AIR BAG" and "SEAT BELT PRE-TENSIONER"

INFOID:000000006566494

The Supplemental Restraint System such as "AIR BAG" and "SEAT BELT PRE-TENSIONER", used along with a front seat belt, helps to reduce the risk or severity of injury to the driver and front passenger for certain types of collision. This system includes seat belt switch inputs and dual stage front air bag modules. The SRS system uses the seat belt switches to determine the front air bag deployment, and may only deploy one front air bag, depending on the severity of a collision and whether the front occupants are belted or unbelted. Information necessary to service the system safely is included in the "SRS AIR BAG" and "SEAT BELT" of this Service Manual.

WARNING:

Always observe the following items for preventing accidental activation.

- To avoid rendering the SRS inoperative, which could increase the risk of personal injury or death in the event of a collision that would result in air bag inflation, all maintenance must be performed by an authorized NISSAN/INFINITI dealer.
- Improper maintenance, including incorrect removal and installation of the SRS, can lead to personal injury caused by unintentional activation of the system. For removal of Spiral Cable and Air Bag Module, see "SRS AIR BAG".
- Never use electrical test equipment on any circuit related to the SRS unless instructed to in this Service Manual. SRS wiring harnesses can be identified by yellow and/or orange harnesses or harness connectors.

PRECAUTIONS WHEN USING POWER TOOLS (AIR OR ELECTRIC) AND HAMMERS

WARNING:

Always observe the following items for preventing accidental activation.

- When working near the Air Bag Diagnosis Sensor Unit or other Air Bag System sensors with the ignition ON or engine running, never use air or electric power tools or strike near the sensor(s) with a hammer. Heavy vibration could activate the sensor(s) and deploy the air bag(s), possibly causing serious injury.
- When using air or electric power tools or hammers, always switch the ignition OFF, disconnect the battery, and wait at least 3 minutes before performing any service.

Precautions Necessary for Steering Wheel Rotation After Battery Disconnection

INFOID:000000006566495

CAUTION:

Comply with the following cautions to prevent any error and malfunction.

- Before removing and installing any control units, first turn the ignition switch to the LOCK position, then disconnect both battery cables.
- After finishing work, confirm that all control unit connectors are connected properly, then re-connect both battery cables.
- Always use CONSULT to perform self-diagnosis as a part of each function inspection after finishing work. If a DTC is detected, perform trouble diagnosis according to self-diagnosis results.

For vehicle with steering lock unit, if the battery is disconnected or discharged, the steering wheel will lock and cannot be turned.

If turning the steering wheel is required with the battery disconnected or discharged, follow the operation procedure below before starting the repair operation.

OPERATION PROCEDURE

1. Connect both battery cables.

NOTE:

Supply power using jumper cables if battery is discharged.

2. Turn the ignition switch to ACC position.
(At this time, the steering lock will be released.)
3. Disconnect both battery cables. The steering lock will remain released with both battery cables disconnected and the steering wheel can be turned.

PRECAUTIONS

< PRECAUTION >

4. Perform the necessary repair operation.
5. When the repair work is completed, re-connect both battery cables. With the brake pedal released, turn the ignition switch from ACC position to ON position, then to LOCK position. (The steering wheel will lock when the ignition switch is turned to LOCK position.)
6. Perform self-diagnosis check of all control units using CONSULT.

Precaution

INFOID:000000006566496

- Disconnect battery negative terminal in advance.
- Disconnect air bag system line in advance.
- Never tamper with or force air bag lid open, as this may adversely affect air bag performance.
- Be careful not to scratch pad and other parts.
- When removing or disassembling any part, be careful not to damage or deform it. Protect parts, which may get in the way with a shop cloth.
- When removing parts with a screwdriver or other tool, cover the tool surface by vinyl tape to protect parts.
- Keep removed parts protected with a shop cloth.
- If a clip is deformed or damaged, replace it.
- If an un reusable part is removed, replace it with a new one.
- Tighten bolts and nuts firmly to the specified torque.
- After reassembly has been completed, make sure each part functions correctly.
- Remove stains in the following way.

Water-soluble stains:

Dip a soft cloth in warm water, and then squeeze it tightly. After wiping the stain, wipe with a soft dry cloth.

Oil stain:

Dissolve a synthetic detergent in warm water (density of 2 to 3%), dip the cloth, then clean off the stain with the cloth. Next, dip the cloth in fresh water and squeeze it tightly. Then clean off the detergent completely. Then wipe the area with a soft dry cloth.

- Never use any organic solvent, such as thinner or benzine.

A
B
C
D
E
F
G
H
I
K
L
M
N
O
P



PREPARATION

< PREPARATION >

PREPARATION

PREPARATION

Special Service Tools

INFOID:000000006566497

The actual shapes of Kent-Moore tools may differ from those of special service tools illustrated here.

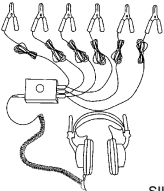
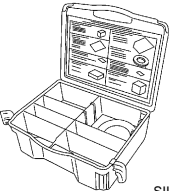
Tool number (Kent-Moore No.) Tool name	Description
<p>(J-39570) Chassis ear</p>  <p style="text-align: right;">SIIA0993E</p>	<p>Locates the noise</p>
<p>(J-43980) NISSAN Squeak and Rattle Kit</p>  <p style="text-align: right;">SIIA0994E</p>	<p>Repairs the cause of noise</p>

Commercial Service Tools

INFOID:000000006566498

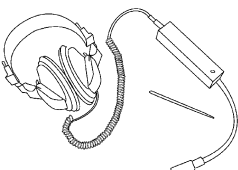
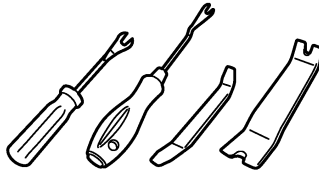
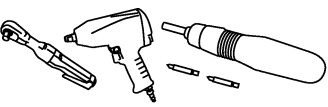
Tool name	Description
<p>Engine ear</p>  <p style="text-align: right;">SIIA0995E</p>	<p>Locates the noise</p>
<p>Remover tool</p>  <p style="text-align: right;">JMKIA3050ZZ</p>	<p>Removes clips, pawls and metal clips</p>
<p>Power tool</p>  <p style="text-align: right;">PIIB1407E</p>	

CLIP LIST

< PREPARATION >

CLIP LIST

Clip List

INFOID:000000006889794

Shapes	Removal & Installation	Shapes	Removal & Installation
	<p>Removal: Remove by bending up with flat-bladed screwdrivers or clip remover.</p>		<p>Removal:</p>
	<p>Removal: Remove with a clip remover.</p>		<p>Removal:</p>
	<p>Removal: Push center pin to catching position. (Do not remove center pin by hitting it.)</p> <p>Installation:</p>		<p>Removal: Holder portion of clip must be spread out to remove rod.</p>
	<p>Removal: Remove by bending up with flat-bladed screwdrivers or clip remover.</p>		<p>Removal:</p> <ol style="list-style-type: none"> Screw out with a Phillips screwdriver. Remove female portion with flat-bladed screwdriver.
	<p>Removal:</p>		<p>Removal:</p> <p>Rotate 45° to remove.</p> <p>Installation:</p>
	<p>Removal:</p>		<p>Removal:</p>

JMJIA3734GB

A
B
C
D
E
F
G
H
I
IP
K
L
M
N
O
P

SQUEAK AND RATTLE TROUBLE DIAGNOSES

< SYMPTOM DIAGNOSIS >

SYMPTOM DIAGNOSIS

SQUEAK AND RATTLE TROUBLE DIAGNOSES

Work Flow

INFOID:000000006566491

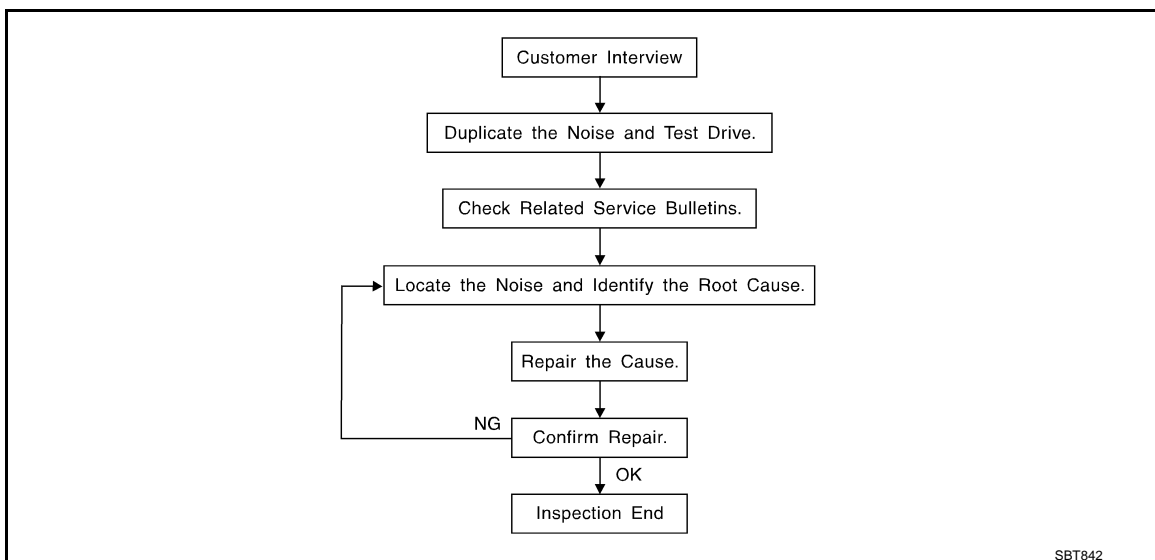

CUSTOMER INTERVIEW

Interview the customer if possible, to determine the conditions that exist when the noise occurs. Use the Diagnostic Worksheet during the interview to document the facts and conditions when the noise occurs and any of customer's comments; refer to [IP-10. "Diagnostic Worksheet"](#). This information is necessary to duplicate the conditions that exist when the noise occurs.

- The customer may not be able to provide a detailed description or the location of the noise. Attempt to obtain all the facts and conditions that exist when the noise occurs (or does not occur).
- If there is more than one noise in the vehicle, perform a diagnosis and repair the noise that the customer is concerned about. This can be accomplished by performing a cruise test on the vehicle with the customer.
- After identifying the type of noise, isolate the noise in terms of its characteristics. The noise characteristics are provided so the customer, service adviser and technician are all speaking the same language when defining the noise.
- Squeak – (Like tennis shoes on a clean floor)
Squeak characteristics include the light contact/fast movement/brought on by road conditions/hard surfaces = higher pitch noise/softer surfaces = lower pitch noises/edge to surface = chirping
- Creak – (Like walking on an old wooden floor)
Creak characteristics include firm contact/slow movement/twisting with a rotational movement/pitch dependent on materials/often brought on by activity.
- Rattle – (Like shaking a baby rattle)
Rattle characteristics include the fast repeated contact/vibration or similar movement/loose parts/missing clip or fastener/incorrect clearance.
- Knock – (Like a knock on a door)
Knock characteristics include hollow sounding/sometimes repeating/often brought on by driver action.
- Tick – (Like a clock second hand)
Tick characteristics include gentle contacting of light materials/loose components/can be caused by driver action or road conditions.
- Thump – (Heavy, muffled knock noise)
Thump characteristics include softer knock/dead sound often brought on by activity.
- Buzz – (Like a bumblebee)
Buzz characteristics include high frequency rattle/firm contact.
- Often the degree of acceptable noise level will vary depending up on the person. A noise that a technician may judge as acceptable may be very irritating to the customer.
- Weather conditions, especially humidity and temperature, may have a great effect on noise level.

DUPLICATE THE NOISE AND TEST DRIVE

SQUEAK AND RATTLE TROUBLE DIAGNOSES

< SYMPTOM DIAGNOSIS >

If possible, drive the vehicle with the customer until the noise is duplicated. Note any additional information on the Diagnostic Worksheet regarding the conditions or location of the noise. This information can be used to duplicate the same conditions when the repair is reconfirmed.

If the noise can be duplicated easily during the test drive, to help identify the source of the noise, try to duplicate the noise with the vehicle stopped by doing one or all of the following:

- 1) Close a door.
 - 2) Tap or push/pull around the area where the noise appears to be coming from.
 - 3) Rev the engine.
 - 4) Use a floor jack to recreate vehicle "twist".
 - 5) At idle, apply engine load (electrical load, half-clutch on M/T models, drive position on A/T models).
 - 6) Raise the vehicle on a hoist and hit a tire with a rubber hammer.
- Drive the vehicle and attempt to duplicate the conditions the customer states exist when the noise occurs.
 - If it is difficult to duplicate the noise, drive the vehicle slowly on an undulating or rough road to stress the vehicle body.

CHECK RELATED SERVICE BULLETINS

After verifying the customer concern or symptom, check ASIST for Technical Service Bulletins (TSBs) related to that concern or symptom.

If a TSB relates to the symptom, follow the procedure to repair the noise.

LOCATE THE NOISE AND IDENTIFY THE ROOT CAUSE

1. Narrow down the noise to a general area. To help pinpoint the source of the noise, use a listening tool (Chassis ear: J-39570, Engine ear and mechanics stethoscope).
2. Narrow down the noise to a more specific area and identify the cause of the noise by:
 - Removing the components in the area that is are suspected to be the cause of the noise.
Do not use too much force when removing clips and fasteners, otherwise clips and fastener can be broken or lost during the repair, resulting in the creation of new noise.
 - Tapping or pushing/pulling the component that is are suspected to be the cause of the noise.
Do not tap or push/pull the component with excessive force, otherwise the noise will be eliminated only temporarily.
 - Feeling for a vibration by hand by touching the component(s) that is are suspected to be the cause of the noise.
 - Placing a piece of paper between components that are suspected to be the cause of the noise.
 - Looking for loose components and contact marks.
Refer to [IP-8, "Inspection Procedure"](#).

REPAIR THE CAUSE

- If the cause is a loose component, tighten the component securely.
- If the cause is insufficient clearance between components:
 - Separate components by repositioning or loosening and retightening the component, if possible.
 - Insulate components with a suitable insulator such as urethane pads, foam blocks, felt cloth tape or urethane tape. A Nissan Squeak and Rattle Kit (J-43980) is available through the authorized Nissan Parts Department.

CAUTION:

Never use excessive force as many components are constructed of plastic and may be damaged.

NOTE:

Always check with the Parts Department for the latest parts information.

The following materials are contained in the Nissan Squeak and Rattle Kit (J-43980). Each item can be ordered separately as needed.

URETHANE PADS [1.5 mm (0.059 in) thick]

Insulates connectors, harness, etc.

- 76268-9E005: 100 × 135 mm (3.937 × 5.315 in)
- 76884-71L01: 60 × 85 mm (2.362 × 3.346 in)
- 76884-71L02: 15 × 25 mm (0.591 × 0.984 in)

INSULATOR (Foam blocks)

Insulates components from contact. Can be used to fill space behind a panel.

- 73982-9E000: 45 mm (1.772 in) thick, 50 × 50 mm (1.969 × 1.969 in)
- 73982-50Y00: 10 mm (0.394 in) thick, 50 × 50 mm (1.969 × 1.969 in)

INSULATOR (Light foam block)

80845-71L00: 30 mm (1.18 in) thick, 30 × 50 mm (1.181 × 1.969in)

FELT CLOTHTAPE

SQUEAK AND RATTLE TROUBLE DIAGNOSES

< SYMPTOM DIAGNOSIS >

Used to insulate where movement does not occur. Ideal for instrument panel applications.

- 68370-4B000: 15 × 25 mm (0.591 × 0.984 in) pad
- 68239-13E00: 5 mm (0.197 in) wide tape roll

The following materials, not found in the kit, can also be used to repair squeaks and rattles.

UHMW (TEFLON) TAPE

Insulates where slight movement is present. Ideal for instrument panel applications.

SILICONE GREASE

Used in place of UHMW tape that is be visible or does not fit. Will only last a few months.

SILICONE SPRAY

Used when grease cannot be applied.

DUCT TAPE

Used to eliminate movement.

CONFIRM THE REPAIR

Confirm that the cause of a noise is repaired by test driving the vehicle. Operate the vehicle under the same conditions as when the noise originally occurred. Refer to the notes on the Diagnostic Worksheet.

Inspection Procedure

INFOID:000000006566492

Refer to Table of Contents for specific component removal and installation information.

INSTRUMENT PANEL

Most incidents are caused by contact and movement between:

1. The cluster lid A and instrument panel
2. Acrylic lens and combination meter housing
3. Instrument panel to front pillar garnish
4. Instrument panel to windshield
5. Instrument panel mounting pins
6. Wiring harnesses behind the combination meter
7. A/C defroster duct and duct joint

These incidents can usually be located by tapping or moving the components to duplicate the noise or by pressing on the components while driving to stop the noise. Most of these incidents can be repaired by applying felt cloth tape or silicon spray (in hard to reach areas). Urethane pads can be used to insulate wiring harness.

CAUTION:

Never use silicone spray to isolate a squeak or rattle. If the area is saturated with silicone, the recheck of repair becomes impossible.

CENTER CONSOLE

Components to pay attention to include:

1. Shifter assembly cover to finisher
2. A/C control unit and cluster lid C
3. Wiring harnesses behind audio and A/C control unit

The instrument panel repair and isolation procedures also apply to the center console.

DOORS

Pay attention to the following:

1. Finisher and inner panel making a slapping noise
2. Inside handle escutcheon to door finisher
3. Wiring harnesses tapping
4. Door striker out of alignment causing a popping noise on starts and stops

Tapping or moving the components or pressing on them while driving to duplicate the conditions can isolate many of these incidents. The areas can usually be insulated with felt cloth tape or insulator foam blocks from the Nissan Squeak and Rattle Kit (J-43980) to repair the noise.

TRUNK

Trunk noises are often caused by a loose jack or loose items put into the trunk by the customer.

In addition look for the following:

1. Trunk lid dumpers out of adjustment

SQUEAK AND RATTLE TROUBLE DIAGNOSES

< SYMPTOM DIAGNOSIS >

2. Trunk lid striker out of adjustment
3. The trunk lid torsion bars knocking together
4. A loose license plate or bracket

Most of these incidents can be repaired by adjusting, securing or insulating the item(s) or component(s) causing the noise.

SUNROOF/HEADLINING

Noises in the sunroof/headlining area can often be traced to one of the following:

1. Sunroof lid, rail, linkage or seals making a rattle or light knocking noise
2. Sunvisor shaft shaking in the holder
3. Front or rear windshield touching headlining and squeaking

Again, pressing on the components to stop the noise while duplicating the conditions can isolate most of these incidents. Repairs usually consist of insulating with felt cloth tape.

SEATS

When isolating seat noise it's important to note the position the seats in and the load placed on the seat when the noise occurs. These conditions should be duplicated when verifying and isolating the cause of the noise.

Cause of seat noise include:

1. Headrest rods and holder
2. A squeak between the seat pad cushion and frame
3. The rear seatback lock and bracket

These noises can be isolated by moving or pressing on the suspected components while duplicating the conditions under which the noise occurs. Most of these incidents can be repaired by repositioning the component or applying urethane tape to the contact area.

UNDERHOOD

Some interior noise may be caused by components under the hood or on the engine wall. The noise is then transmitted into the passenger compartment.

Causes of transmitted underhood noise include:

1. Any component mounted to the engine wall
2. Components that pass through the engine wall
3. Engine wall mounts and connectors
4. Loose radiator mounting pins
5. Hood bumpers out of adjustment
6. Hood striker out of adjustment

These noises can be difficult to isolate since they cannot be reached from the interior of the vehicle. The best method is to secure, move or insulate one component at a time and test drive the vehicle. Also, engine RPM or load can be changed to isolate the noise. Repairs can usually be made by moving, adjusting, securing, or insulating the component causing the noise.

A
B
C
D
E
F
G
H
I
IP
K
L
M
N
O
P

SQUEAK AND RATTLE TROUBLE DIAGNOSES

< SYMPTOM DIAGNOSIS >

Diagnostic Worksheet

INFOID:000000006566493



SQUEAK & RATTLE DIAGNOSTIC WORKSHEET

Dear Infiniti Customer:

We are concerned about your satisfaction with your Infiniti vehicle. Repairing a squeak or rattle sometimes can be very difficult. To help us fix your Infiniti right the first time, please take a moment to note the area of the vehicle where the squeak or rattle occurs and under what conditions. You may be asked to take a test drive with a service consultant or technician to ensure we confirm the noise you are hearing.

I. WHERE DOES THE NOISE COME FROM? (circle the area of the vehicle)

The illustrations are for reference only, and may not reflect the actual configuration of your vehicle.

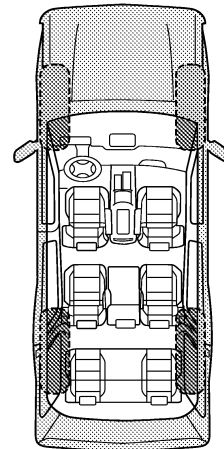
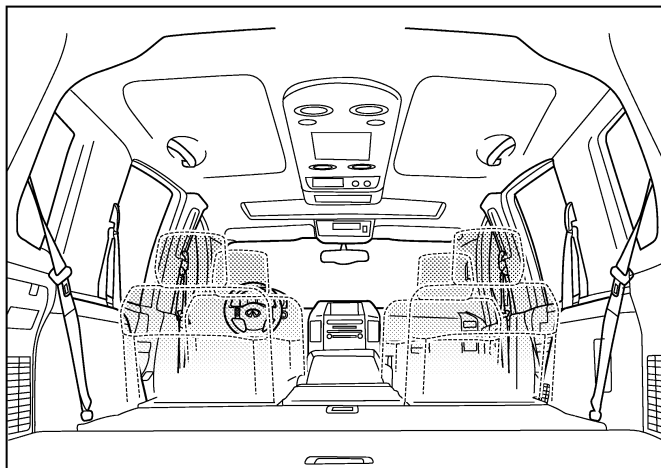
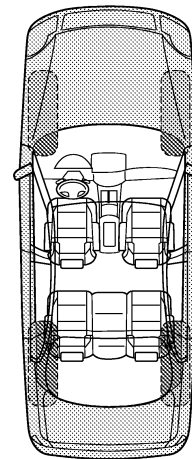
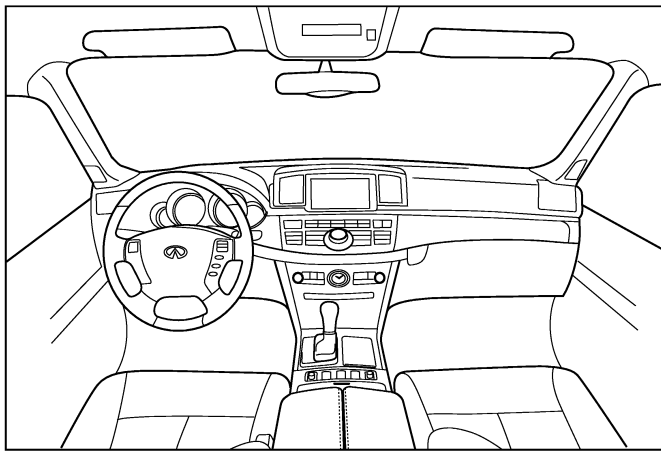

Continue to page 2 of the worksheet and briefly describe the location of the noise or rattle. In addition, please indicate the conditions which are present when the noise occurs.

PIIB8741E

SQUEAK AND RATTLE TROUBLE DIAGNOSES

< SYMPTOM DIAGNOSIS >

SQUEAK & RATTLE DIAGNOSTIC WORKSHEET - page 2

Briefly describe the location where the noise occurs:

II. WHEN DOES IT OCCUR? (please check the boxes that apply)

- | | |
|---|--|
| <input type="checkbox"/> anytime | <input type="checkbox"/> after sitting out in the rain |
| <input type="checkbox"/> 1st time in the morning | <input type="checkbox"/> when it is raining or wet |
| <input type="checkbox"/> only when it is cold outside | <input type="checkbox"/> dry or dusty conditions |
| <input type="checkbox"/> only when it is hot outside | <input type="checkbox"/> other: |

III. WHEN DRIVING:

- through driveways
- over rough roads
- over speed bumps
- only about ____ mph
- on acceleration
- coming to a stop
- on turns: left, right or either (circle)
- with passengers or cargo
- other: _____
- after driving ____ miles or ____ minutes

IV. WHAT TYPE OF NOISE

- squeak (like tennis shoes on a clean floor)
- creak (like walking on an old wooden floor)
- rattle (like shaking a baby rattle)
- knock (like a knock at the door)
- tick (like a clock second hand)
- thump (heavy, muffled knock noise)
- buzz (like a bumble bee)

TO BE COMPLETED BY DEALERSHIP PERSONNEL

Test Drive Notes:

	YES	NO	Initials of person performing
Vehicle test driven with customer	<input type="checkbox"/>	<input type="checkbox"/>	_____
- Noise verified on test drive	<input type="checkbox"/>	<input type="checkbox"/>	_____
- Noise source located and repaired	<input type="checkbox"/>	<input type="checkbox"/>	_____
- Follow up test drive performed to confirm repair	<input type="checkbox"/>	<input type="checkbox"/>	_____

VIN: _____ Customer Name: _____
W.O.# _____ Date: _____

This form must be attached to Work Order

PIIB8742E

A
B
C
D
E
F
G
H
I
IP
K
L
M
N
O
P

INSTRUMENT PANEL ASSEMBLY

< REMOVAL AND INSTALLATION >

REMOVAL AND INSTALLATION

INSTRUMENT PANEL ASSEMBLY

Exploded View

INFOID:000000006566499

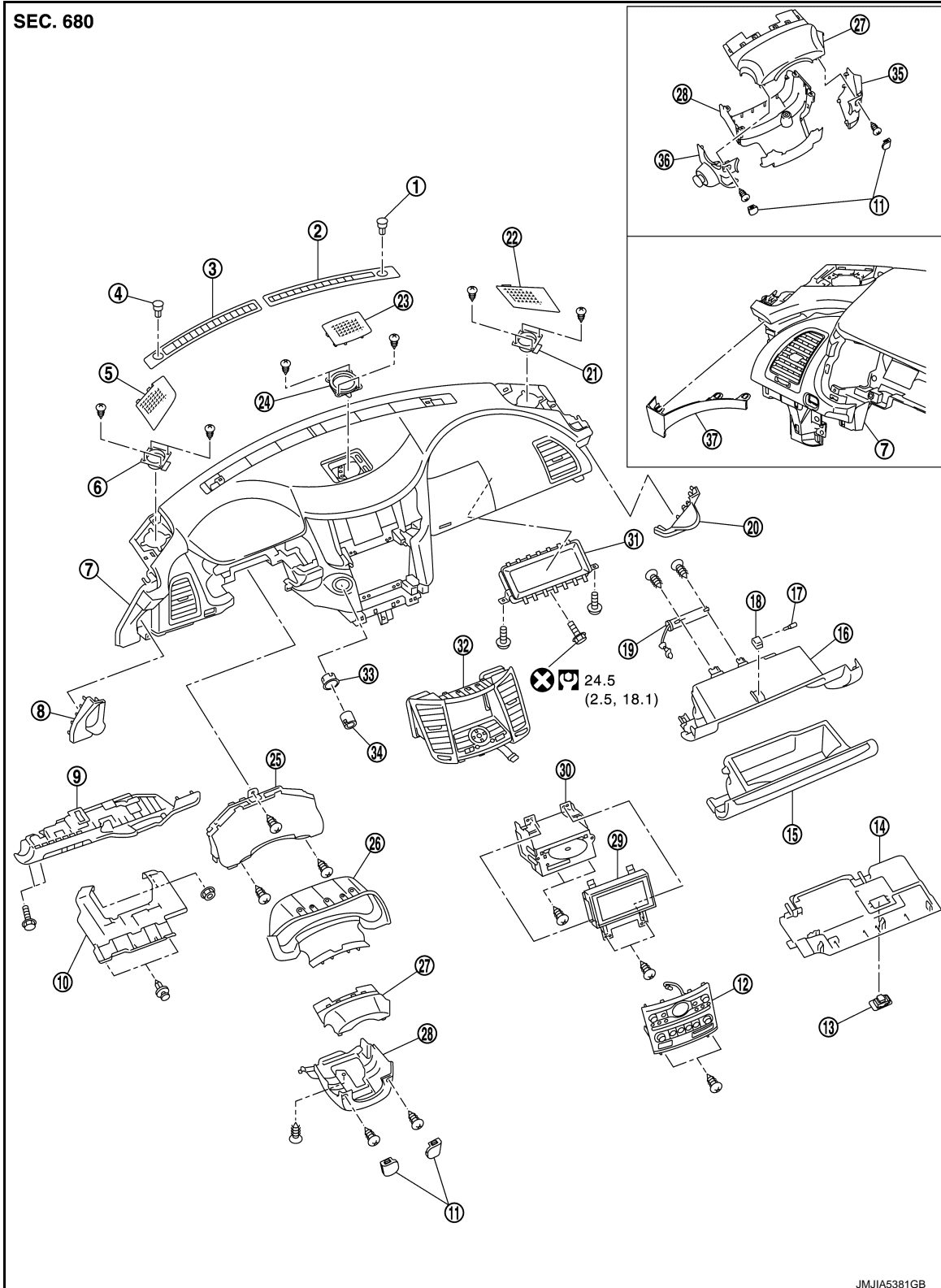

INSTRUMENT PANEL ASSEMBLY

< REMOVAL AND INSTALLATION >

- | | | | |
|---------------------------------|-----------------------------------|-----------------------------------|---|
| 1. Optical sensor | 2. Front defroster grille RH | 3. Front defroster grille LH | A |
| 4. Sunload sensor | 5. Speaker grille LH | 6. Front squawker LH | |
| 7. Instrument panel assembly | 8. Instrument side finisher LH | 9. Instrument lower panel LH | B |
| 10. Instrument lower cover LH | 11. Steering column mask | 12. Cluster lid C | |
| 13. Illumination lamp | 14. Instrument lower cover RH | 15. Glove box assembly | C |
| 16. Instrument lower panel RH | 17. Socket and bulb | 18. Illumination lamp | |
| 19. Glove box damper | 20. Instrument side finisher RH | 21. Front squawker RH | D |
| 22. Speaker grille RH | 23. Center speaker grille | 24. Center speaker | |
| 25. Combination meter | 26. Cluster lid A | 27. Steering column upper cover | E |
| 28. Steering column lower cover | 29. Display unit | 30. AV control unit (audio unit) | |
| 31. Passenger air bag module | 32. Cluster lid D | 33. Ignition switch cover | F |
| 34. Push button ignition switch | 35. Steering column side cover RH | 36. Steering column side cover LH | |
| 37. Instrument finisher A | | | G |

 : Always replace after every disassembly.

 : N·m (kg-m, ft-lb)

Removal and Installation

INFOID:000000006566500

WORK STEP

When removing instrument panel assembly, combination meter, AV C/U (audio unit), instrument finisher A and center console assembly take steps in the order shown by the number below.

PARTS	INSTRUMENT PANEL ASSEMBLY	COMBINATION METER	AV control unit (audio unit)	INSTRUMENT FINISHER A	CENTER CONSOLE ASSEMBLY
Console upper finisher	[1]		[1]		[1]
Console finisher assembly	[2]		[2]		[2]
Console switch finisher	[3]				[3]
Console pocket assembly	[4]		[3]		[4]
Console rear finisher	[5]				[5]
Rear ventilator duct	[6]				[6]
Center console assembly	[7]				[7]
Instrument lower cover LH	[8]	[1]		[1]	
Instrument lower panel LH	[9]	[2]		[2]	
Front body side welt LH	[10]			[3]	
Instrument side finisher LH	[11]			[4]	
Instrument finisher A				[5]	
Front pillar garnish LH	[12]				
Speaker grille LH	[13]				
Front squawker LH	[14]				
Steering wheel	[15]				
Steering column cover	[16]	[3]			
Combination switch	[17]	[4]			
Paddle switch LH/RH	[18]				
Cluster lid A	[19]	[5]			
Combination meter	[20]	[6]			
Center speaker grille	[21]				
Center speaker	[22]				

INSTRUMENT PANEL ASSEMBLY

< REMOVAL AND INSTALLATION >

Inside key antenna	[23]				
Cluster lid C	[24]		[4]		
Cluster lid D	[25]		[5]		
Front display unit	[26]		[6]		
AV control unit (audio unit)	[27]		[7]		
Push button ignition switch	[28]				
Front defroster grille LH	[29]				
Front defroster grille RH	[30]				
Glove box assembly	[31]				
Instrument lower cover RH	[32]				
Instrument lower panel RH	[33]				
Front body side welt RH	[34]				
Instrument side finisher RH	[35]				
Front pillar garnish RH	[36]				
Speaker grille RH	[37]				
Front squawker RH	[38]				
Instrument panel assembly	[39]				

[]: Number indicates step in removal procedures.

WARNING:

Before servicing, turn ignition switch OFF, disconnect battery negative terminal and wait 3 minutes or more.

CAUTION:

When removing, always use a remover tool that is made of plastic.

REMOVAL

1. Remove console upper finisher.
 1. Open the console lid.
 2. Remove console upper finisher (1) fixing pawls with remover tool (A).
 3. Pull back console upper finisher.

 : Pawl

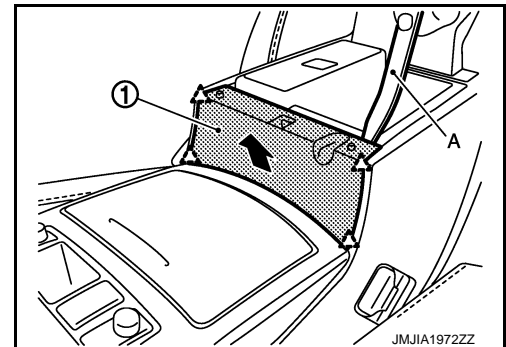

2. Remove console finisher assembly.
 1. Remove selector lever knob. Refer to [TM-193, "Removal and Installation"](#).
 2. Remove console finisher assembly (1) fixing clips with remover tool (A).
 3. Pull up console finisher assembly.
 4. Disconnect harness connector.

 : Clip

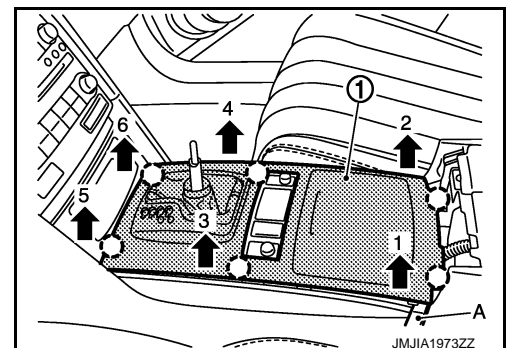

INSTRUMENT PANEL ASSEMBLY

< REMOVAL AND INSTALLATION >

3. Remove console switch finisher.
 1. Remove console switch finisher (1) fixing screws (A).
 2. Pull up console switch finisher.
 3. Disconnect harness connectors.

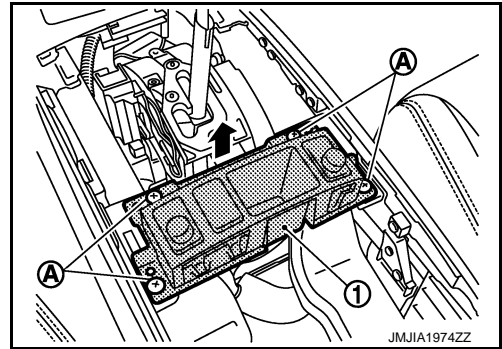

4. Remove console pocket assembly.
 1. Pull back console pocket assembly (1), and disengage clips.
 2. Disconnect harness connector.

 : Clip

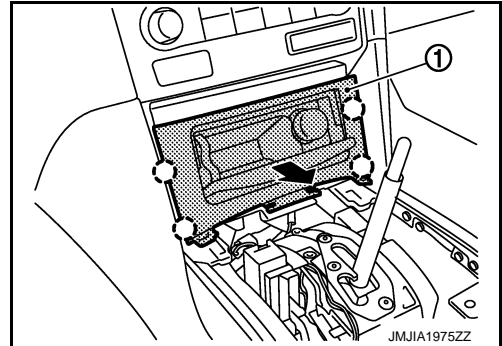

5. Disconnect USB connector harness connector. Refer to [AV-398. "Removal and Installation"](#).
6. Disconnect auxiliary input jacks harness connector. Refer to [AV-656. "Removal and Installation"](#).
7. Disconnect console power socket harness connector. Refer to [PWO-20. "CONSOLE POWER SOCKET : Removal and Installation"](#).
8. Remove center console assembly fixing screws (A).

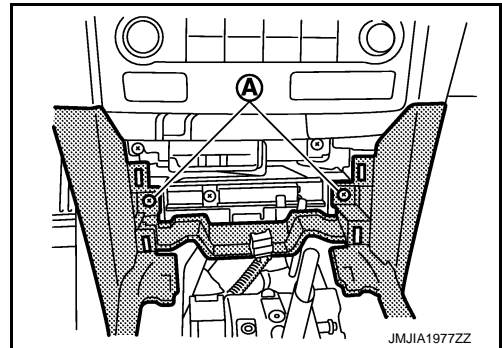

9. Remove console rear finisher.
 1. Put front seat to frontmost position.
 2. Pull back the console rear finisher (1) with remover tool (A).
 3. Disconnect harness connectors.

 : Metal clip

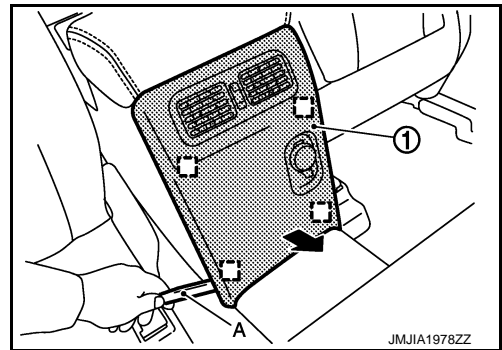

A
B
C
D
E
F
G
H
I
IP
K
L
M
N
O
P

INSTRUMENT PANEL ASSEMBLY

< REMOVAL AND INSTALLATION >

10. Remove rear ventilator duct (1).
Refer to [VTL-16, "REAR VENTILATOR DUCT 1 : Removal and Installation"](#).
11. Remove center console fixing screws (A).

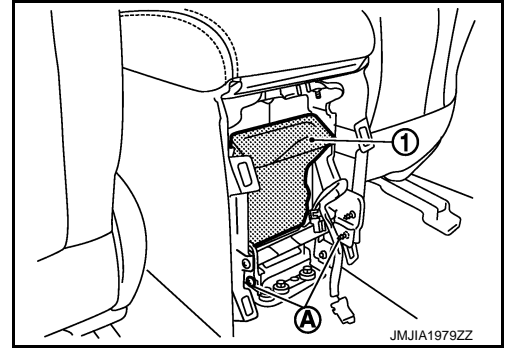

12. Remove center console assembly.
 1. Put front seat to rearmost position.
 2. Pull back and lift up center console assembly (1).

 : Clip

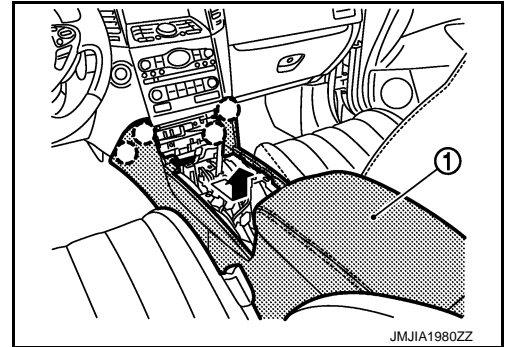

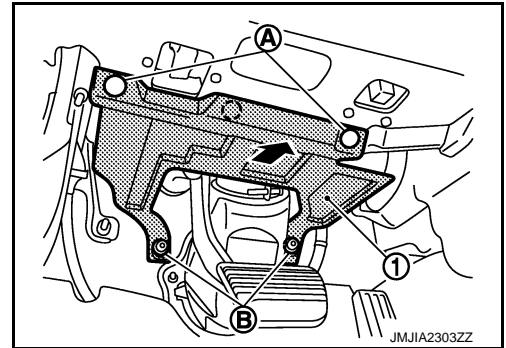

13. Remove instrument lower cover LH (VK engine model only).
 1. Remove instrument lower cover LH (1) fixing clips (A) and plastic nuts (B).
 2. Pull back instrument lower cover LH.

 : Clip



14. Remove instrument lower panel LH.
 1. Remove hood opener lever fixing bolts.
 2. Pull back instrument lower panel LH (1).

 : Clip
 : Pawl

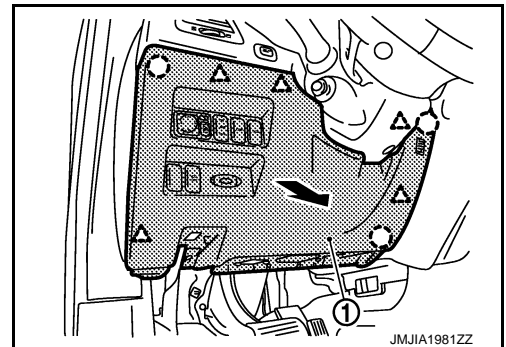

INSTRUMENT PANEL ASSEMBLY

< REMOVAL AND INSTALLATION >

- Remove skirt clips of steering column lower cover (2).

 : Clip

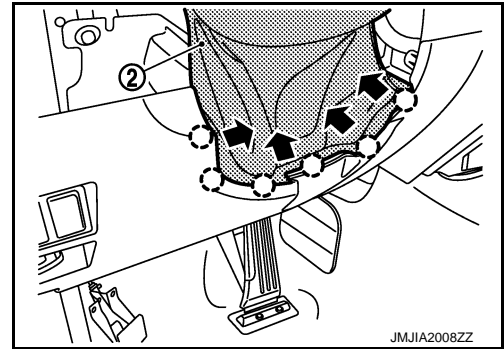

- Release data link connector (pawl) then remove it from instrument lower panel LH.
- Disconnect harness connectors and aspirator duct.

- Remove front body side welt LH. Refer to [INT-18, "Removal and Installation"](#).
- Remove instrument side finisher LH.
Pull back instrument side finisher LH (1).

 : Clip

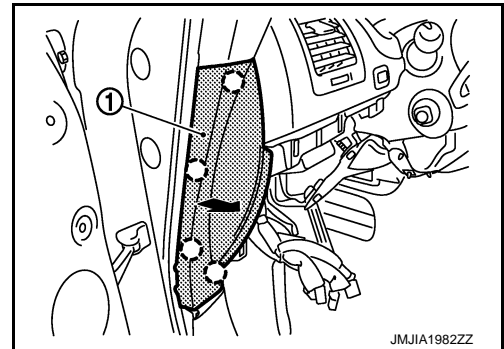

- Remove instrument finisher A.
 - Insert remover tool (A) between instrument finisher A and instrument panel assembly to disengage the pawls as shown in the figure.
 - Pull back instrument finisher A.

 : Pawl

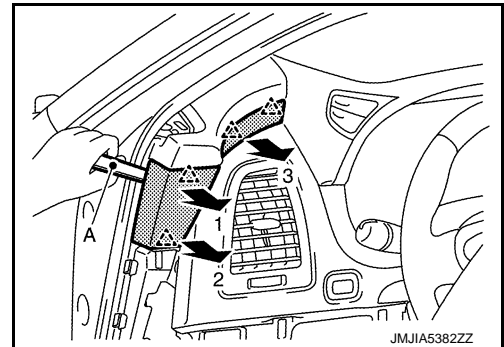

- Remove front pillar garnish LH. Refer to [INT-18, "Removal and Installation"](#).
- Remove speaker grille LH.
 - Remove speaker grille LH (1) fixing pawls with remover tool (A).
 - Pull up and back speaker grille LH (1).

 : Pawl

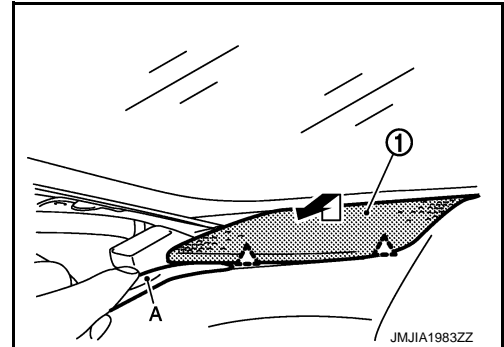

- Remove front squawker. Refer to [AV-166, "Exploded View"](#).
- Remove steering wheel. Refer to [ST-17, "Removal and Installation"](#).
- Remove steering column covers.

A
B
C
D
E
F
G
H
I
IP
K
L
M
N
O
P

INSTRUMENT PANEL ASSEMBLY

< REMOVAL AND INSTALLATION >

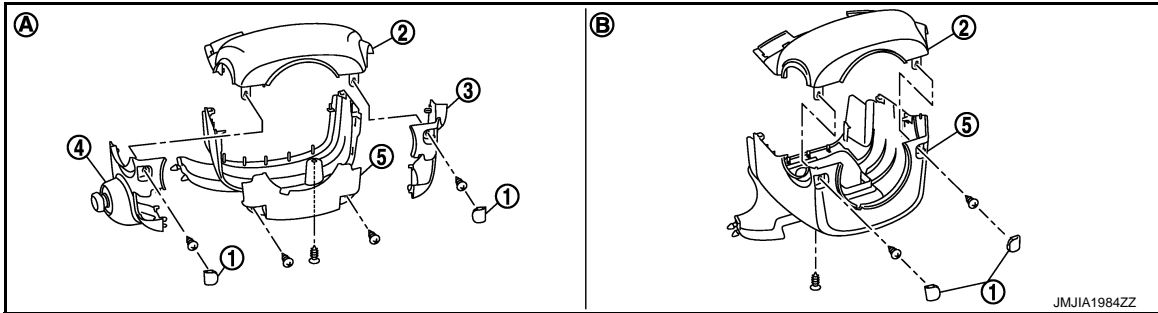

(A) Column cover (with PADDLE SHIFTER)

(B) Column cover (without PADDLE SHIFTER)

1. Remove steering column mask (1) and then remove steering column cover fixing screws.
2. Remove skirt clips and pawls of cluster lid A (6).

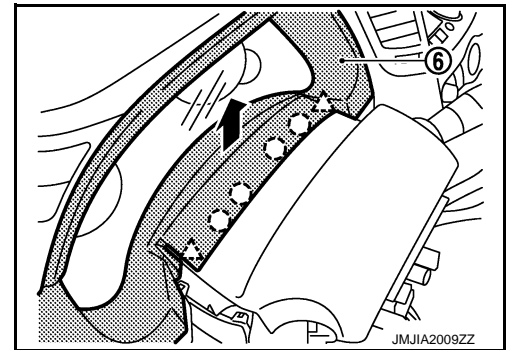
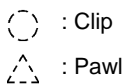

3. Pull up steering column upper cover (2), and then remove steering column upper cover.
4. Remove steering column side cover RH (3) fixing pawls and then remove steering column side cover RH. (with PADDLE SHIFTER)
5. Pull the steering column side cover LH (4) to the left side. (with PADDLE SHIFTER)
6. Disconnect ADP steering switch connector. (with ADP)
7. Remove steering column lower cover (5) fixing screws.
8. Pull down steering column lower cover and then remove steering column lower cover.

23. Remove combination switch. Refer to [BCS-97, "Removal and Installation"](#).
24. Remove paddle switch LH/RH (with PADDLE SHIFTER). Refer to [TM-510, "Exploded View"](#).
25. Remove cluster lid A.
 1. Pull back cluster lid A (1), and disengage pawls.
 2. Remove cluster lid A.

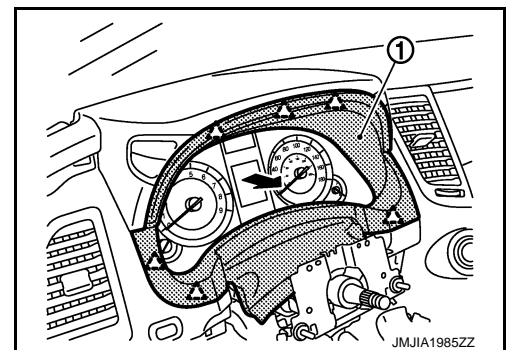
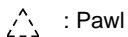

26. Remove combination meter. Refer to [MWI-187, "Exploded View"](#).

INSTRUMENT PANEL ASSEMBLY

< REMOVAL AND INSTALLATION >

27. Disconnect harness connector (A).
28. Remove instrument harness (1) fixing clip (B).

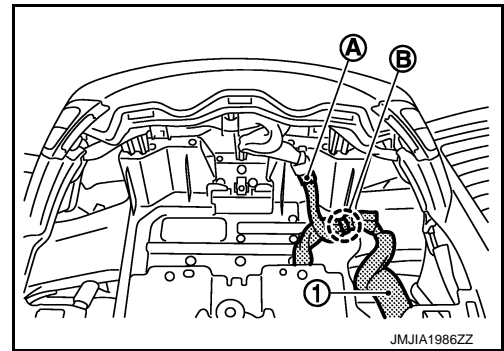

29. Disconnect trip A/B reset switch (1) harness connector (A). Refer to [MWI-190, "Exploded View"](#).

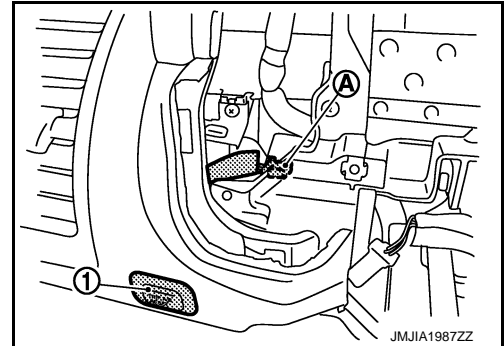

30. Remove center speaker grille.
 1. Disengage center speaker grille (1) fixing clips and pawls with remover tool (A).
 2. Pull up center speaker grille.

- : Clip
- △ : Pawl

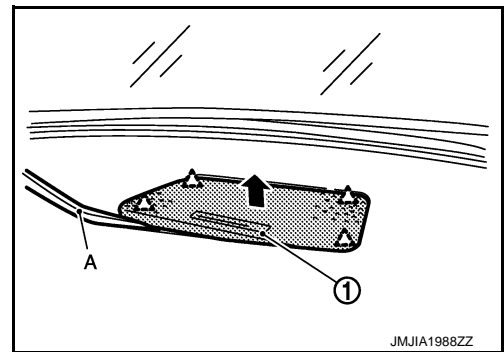

31. Remove center speaker. Refer to [AV-391, "Exploded View"](#).
32. Remove inside key antenna. Refer to [DLK-297, "INSTRUMENT CENTER : Removal and Installation"](#).
33. Remove cluster lid C.

1. Remove cluster lid C (1) fixing screws (A).
2. Pull down and back cluster lid C.
3. Disconnect harness connectors.

- △ : Pawl

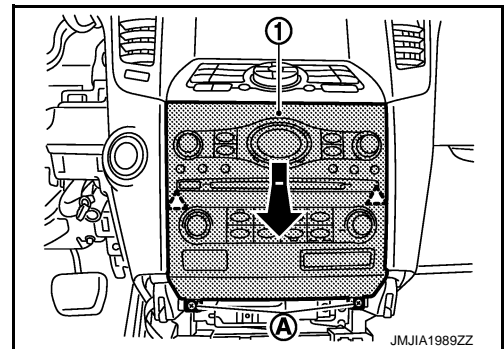

A
B
C
D
E
F
G
H
I
IP
K
L
M
N
O
P

INSTRUMENT PANEL ASSEMBLY

< REMOVAL AND INSTALLATION >

34. Remove cluster lid D.

1. Remove cluster lid D (1) fixing screws (A).
2. Pull back cluster lid D.
3. Disconnect harness connectors.

 : Pawl

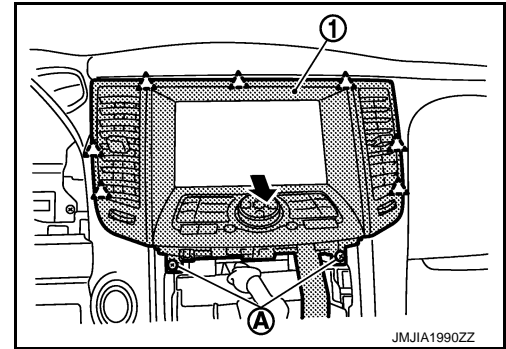

35. Remove front display unit. Refer to [AV-163, "Removal and Installation"](#).

36. Remove AV control unit. Refer to [AV-161, "Removal and Installation"](#).

37. Remove push button ignition switch. Refer to [SEC-276, "Removal and Installation"](#).

38. Remove front defroster grille LH. Refer to [VTL-13, "FRONT DEFROSTER GRILLE : Removal and Installation"](#).

39. Remove front defroster grille RH. Refer to [VTL-13, "FRONT DEFROSTER GRILLE : Removal and Installation"](#).

40. Remove glove box assembly.

1. Open the glove box.
2. Pull back glove box assembly (1).

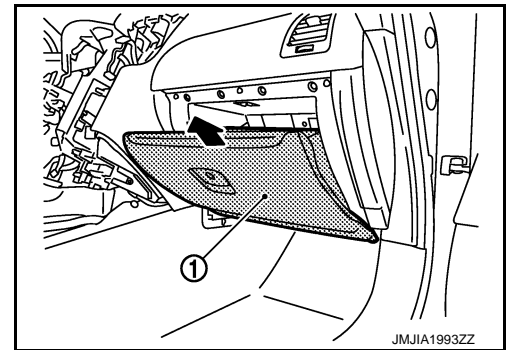

3. Remove damper pin (1) of left side.

 : Clip

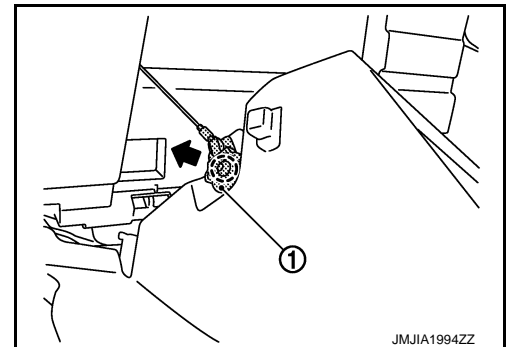

41. Remove instrument lower cover RH.

1. Pull downward, disengage pawls.
2. Pull back instrument lower cover RH (1).
3. Disconnect illumination lamp harness connector.

 : Pawl

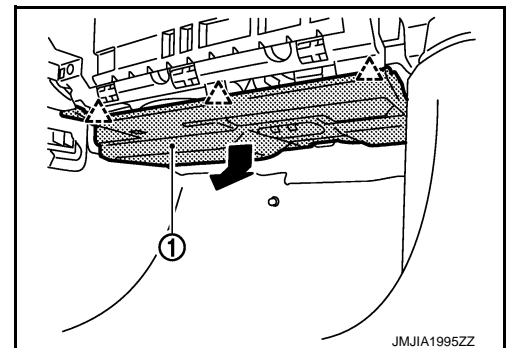

INSTRUMENT PANEL ASSEMBLY

< REMOVAL AND INSTALLATION >

42. Remove instrument lower panel RH.
1. Remove instrument lower panel RH (1) fixing screws (A).
 2. Pull back instrument lower panel RH.
 3. Disconnect glove box lamp harness connector.

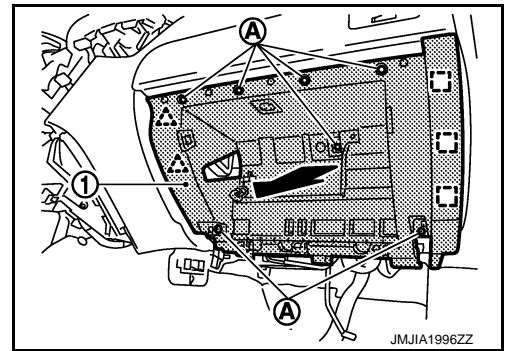
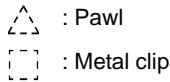

43. Disconnect passenger air bag module connector. Refer to [SR-17, "Exploded View"](#).
44. Remove passenger air bag module fixing bolt. Refer to [SR-17, "Removal and Installation"](#).
45. Remove front body side welt RH. Refer to [INT-18, "Removal and Installation"](#).
46. Remove instrument side finisher RH.
1. Insert a remover tool into lower space.
 2. Pull the instrument side finisher RH (1) crosswise.

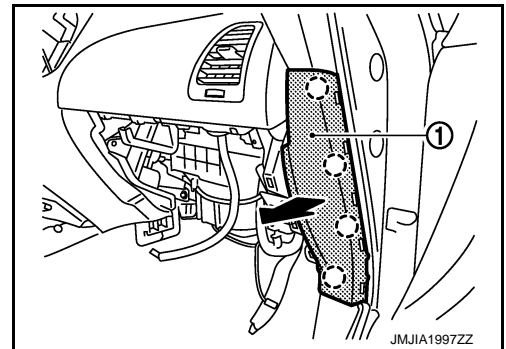
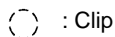

47. Remove front pillar garnish RH. Refer to [INT-18, "Removal and Installation"](#).
48. Remove speaker grille RH.
1. Remove speaker grille RH (1) fixing pawls with remover tool (A).
 2. Pull up and back speaker grille RH (1).

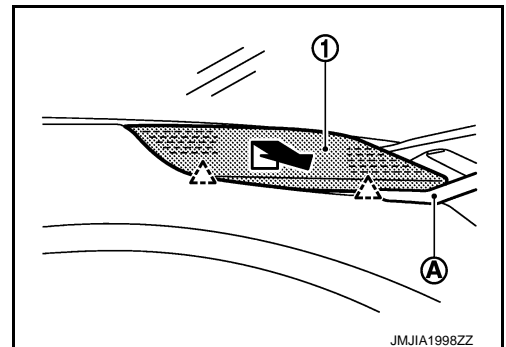
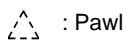

49. Remove front squawker RH. Refer to [AV-166, "Exploded View"](#).
50. Disconnect antenna connectors (A).
51. Remove harness clips (B).

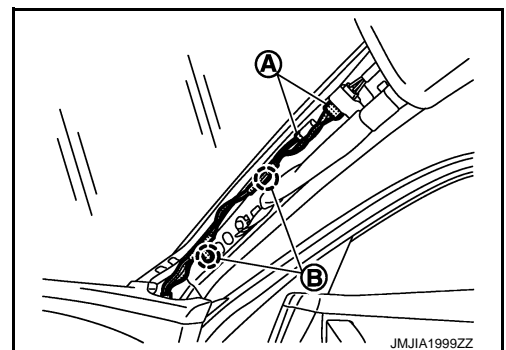

52. Remove instrument panel assembly.

A
B
C
D
E
F
G
H
I
IP
K
L
M
N
O
P

INSTRUMENT PANEL ASSEMBLY

< REMOVAL AND INSTALLATION >

1. Remove instrument panel assembly mounting bolts (A), screws (B) and clips (C).

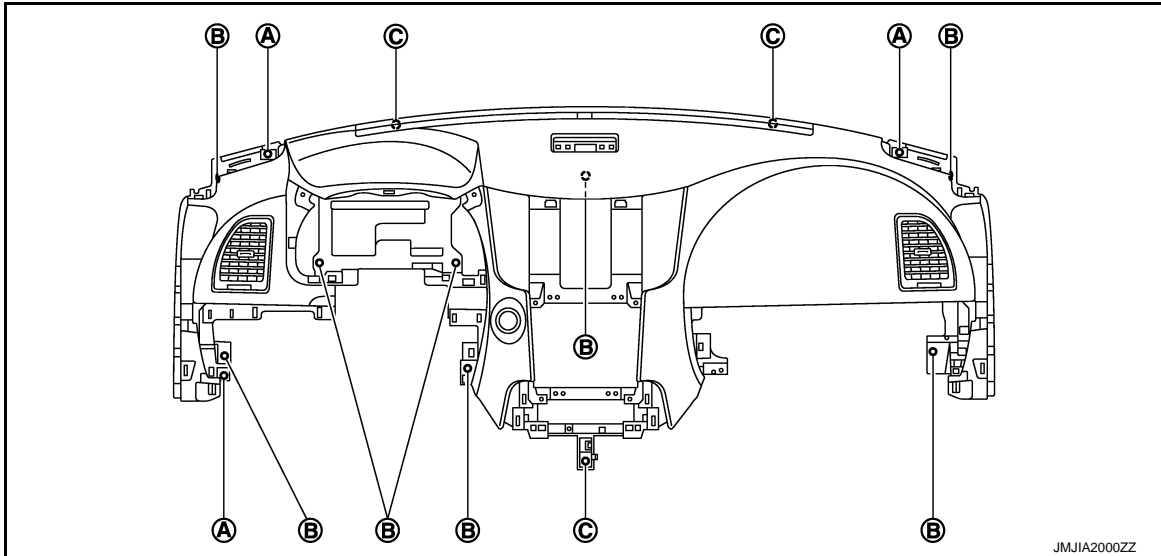

CAUTION:

Cover tool with a shop cloth to prevent windshield glass being damaged.

2. Remove instrument panel assembly from passenger door opening portion.

CAUTION:

- **Cover center console upper surface with a shop cloth to prevent it from being damaged.**
- **When removing instrument panel assembly, 2 workers are required so as to prevent it from dropping.**

53. Remove the following parts after removing instrument panel assembly.

- Passenger air bag module: Refer to [SR-17. "Removal and Installation"](#).
- Side ventilator grille LH/RH: Refer to [VTL-12. "SIDE VENTILATOR GRILLE : Removal and Installation"](#).
- Ventilator duct LH/RH: Refer to [VTL-14. "VENTILATOR DUCT : Removal and Installation"](#).
- Adaptor duct: Refer to [VTL-14. "ADAPTOR DUCT : Removal and Installation"](#).
- Defroster nozzle: Refer to [VTL-15. "DEFROSTER NOZZLE : Removal and Installation"](#).
- Side defroster nozzle LH/RH: Refer to [VTL-15. "SIDE DEFROSTER NOZZLE : Removal and Installation"](#).
- Antenna feeder: Refer to [AV-181. "Feeder Layout"](#).
- GPS antenna: Refer to [AV-400. "Exploded View"](#).
- Trip A/B reset switch: Refer to [MWI-190. "Removal and Installation"](#).

INSTALLATION

Note the following items, and then install in the reverse order of removal.

CAUTION:

- **Never use the steering wheel mounting nut after removal, replace with the new nut.**
- **Never use the driver air bag module mounting bolts after removal, replace with the new bolts.**
- **Never use the passenger air bag module mounting bolt after removal, replace with the new bolt.**

CENTER CONSOLE ASSEMBLY

< REMOVAL AND INSTALLATION >

CENTER CONSOLE ASSEMBLY

Exploded View

INFOID:000000006566501

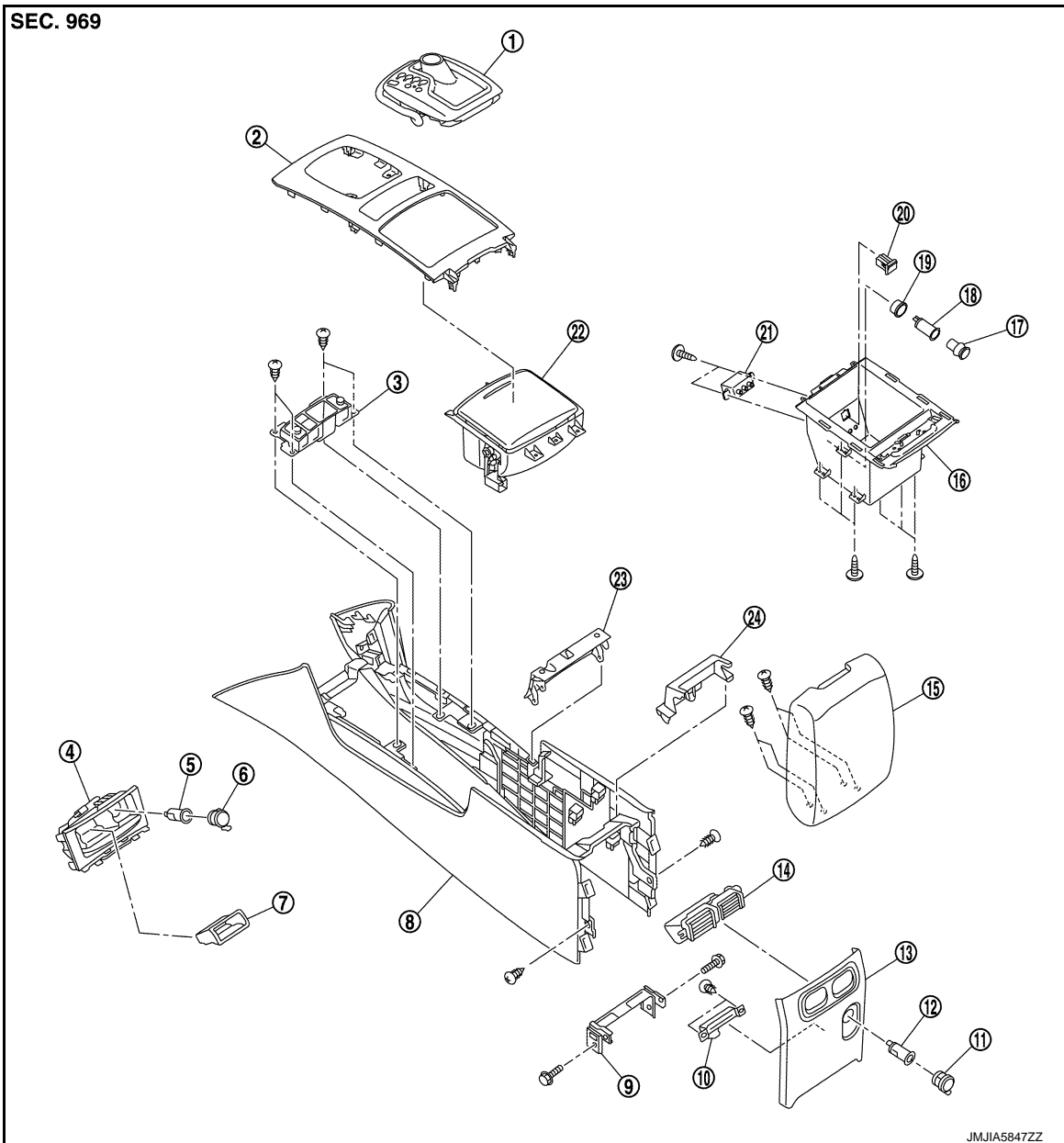

- | | | |
|----------------------------|------------------------------|----------------------------|
| 1. Indicator assembly | 2. Console finisher assembly | 3. Console switch finisher |
| 4. Console pocket assembly | 5. Socket inner case | 6. Socket knob |
| 7. Pocket | 8. Center console assembly | 9. Console bracket |
| 10. Inside key antenna | 11. Socket knob | 12. Socket inner case |
| 13. Console rear finisher | 14. Rear ventilator grille | 15. Console lid assembly |
| 16. Console box assembly | 17. Socket knob | 18. Socket inner case |
| 19. Socket ring | 20. USB connector | 21. Auxiliary input jacks |
| 22. Cup holder assembly | 23. Console upper finisher | 24. Console hinge mask |

Removal and Installation

INFOID:000000006566502

CAUTION:
When removing, always use a remover tool that is made of plastic.

A
B
C
D
E
F
G
H
I
IP
K
L
M
N
O
P

CENTER CONSOLE ASSEMBLY

< REMOVAL AND INSTALLATION >

REMOVAL

1. Remove selector lever knob. Refer to [TM-193, "Removal and Installation"](#).
2. Remove console upper finisher.
 1. Open the console lid.
 2. Remove console upper finisher (1) fixing pawls with remover tool (A).
 3. Pull back console upper finisher.

 : Pawl

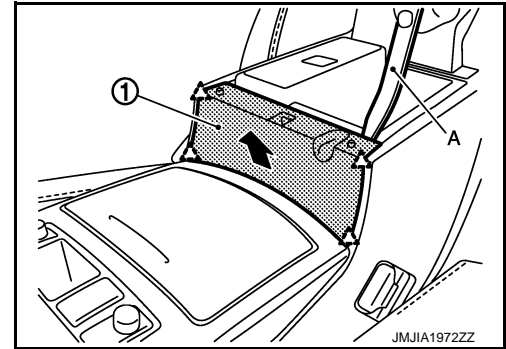

3. Remove console finisher assembly.
 1. Remove console finisher assembly (1) fixing clips with remover tool (A).
 2. Pull up console finisher assembly.
 3. Disconnect harness connector.

 : Clip

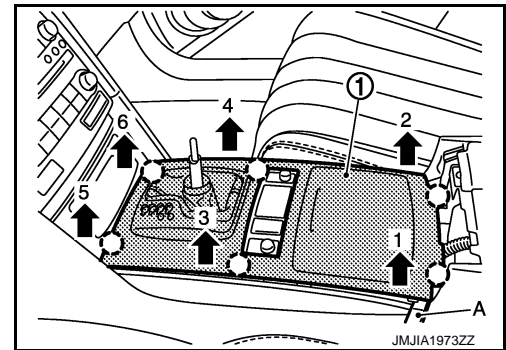

4. Remove console switch finisher.
 1. Remove console switch finisher (1) fixing screws (A).
 2. Pull up console switch finisher.
 3. Disconnect harness connectors.

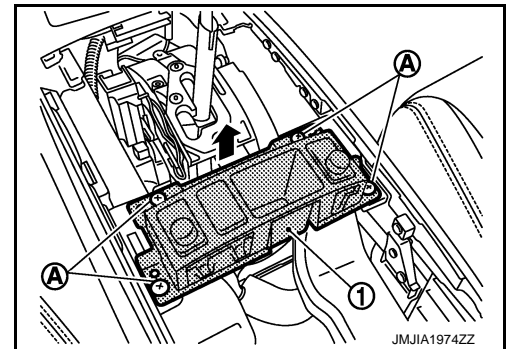

5. Remove console pocket assembly.
 1. Pull back console pocket assembly (1), and disengage clips.
 2. Disconnect harness connector.

 : Clip

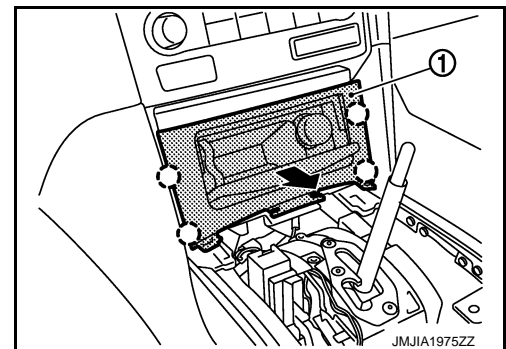

6. Disconnect USB connector harness connector. Refer to [PWO-20, "CONSOLE POWER SOCKET : Removal and Installation"](#).
7. Disconnect auxiliary input jacks harness connector. Refer to [AV-656, "Removal and Installation"](#).
8. Disconnect console power socket harness connector. Refer to [AV-657, "Removal and Installation"](#).

CENTER CONSOLE ASSEMBLY

< REMOVAL AND INSTALLATION >

9. Remove center console assembly fixing screws (A).

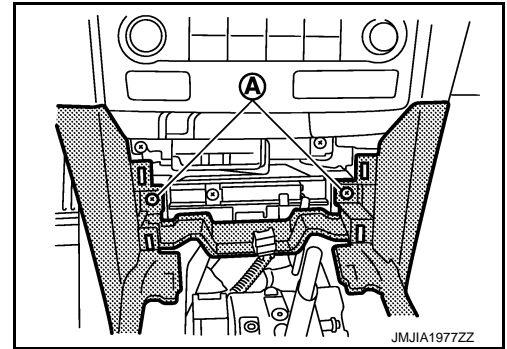

10. Put front seat to front most position.

11. Remove console rear finisher.

1. Pull back the console rear finisher (1) with remover tool (A).
2. Disconnect harness connectors.

 : Metal clip

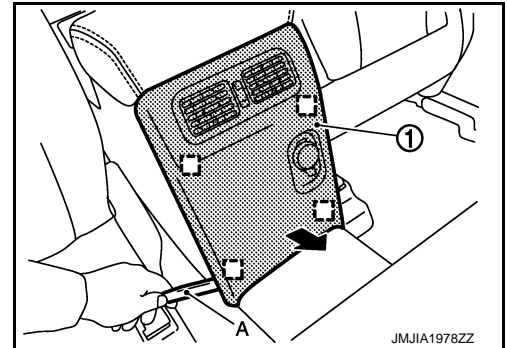

12. Remove rear ventilator duct (1).

Refer to [VTL-16. "REAR VENTILATOR DUCT 1 : Removal and Installation"](#).

13. Remove center console fixing screws (A).

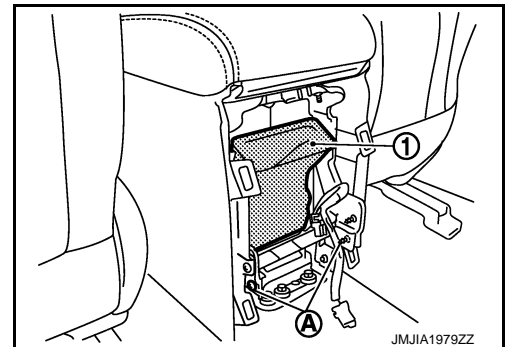

14. Remove center console assembly.

Pull back and lift up center console assembly (1).

 : Clip

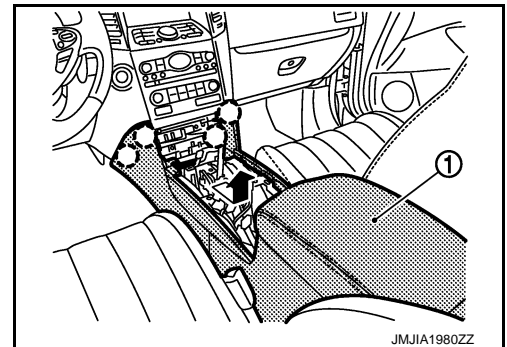

INSTALLATION

Install in the reverse order of removal.

Disassembly and Assembly

INFOID:000000006566503

CAUTION:

When disassembling, always use a remover tool that is made of plastic.

DISASSEMBLY

1. Remove center console assembly. Refer to [IP-23. "Removal and Installation"](#).

CENTER CONSOLE ASSEMBLY

< REMOVAL AND INSTALLATION >

2. Remove console lid assembly.

1. Open the console lid.
2. Remove console hinge mask (1) fixing pawls with remover tool (A).

 : Pawl

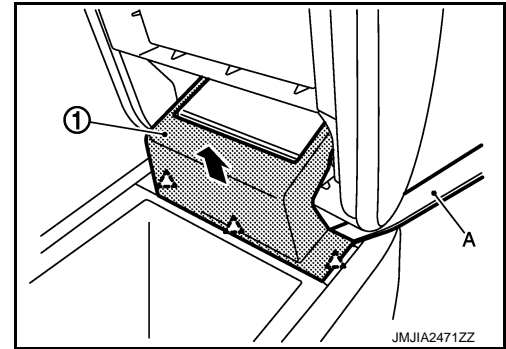

3. Remove console lid assembly (1) fixing screws (A), and then remove console lid assembly.

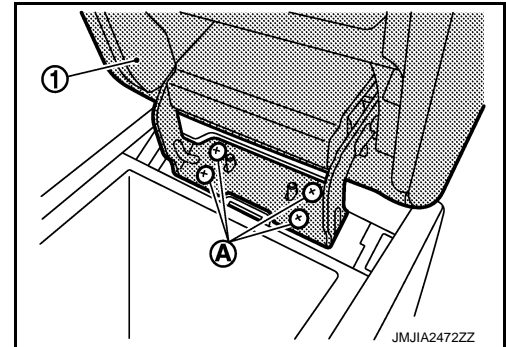

3. Remove console box assembly.

1. Remove console pad LH.
 - Remove console pad LH (1) fixing screws (A).
 - Pull toward the arrow direction.

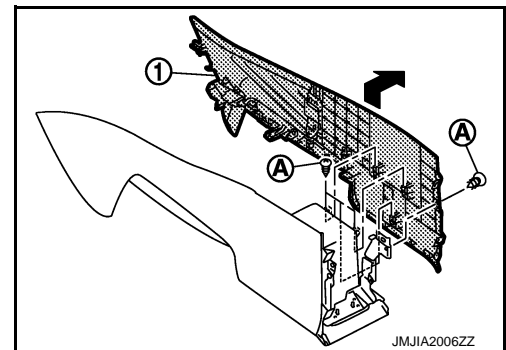

2. Remove console pad RH.
 - Remove console pad RH (1) fixing screws (A).
 - Pull toward the arrow direction.
 - Remove console rear bracket (2).
 - Remove console box assembly (3).

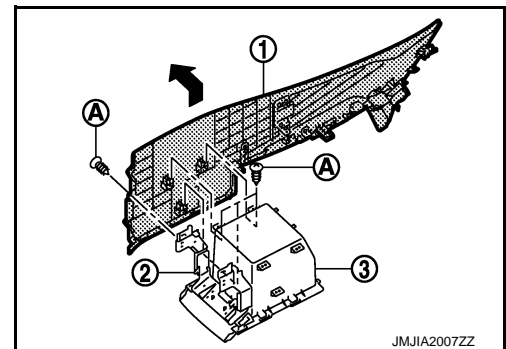

NOTE:

- Removal and installation of USB connector: Refer to [AV-176, "Removal and Installation"](#).
- Removal and installation of auxiliary input jacks: Refer to [AV-656, "Removal and Installation"](#).
- Removal and installation of console power socket: Refer to [PWO-20, "CONSOLE POWER SOCKET : Removal and Installation"](#).

ASSEMBLY

Assemble in the reverse order of disassembly.