

SECTION **SR**  
SRS AIRBAG

A  
B  
C  
D  
E  
F  
G  
SR  
I  
J  
K  
L  
M  
N  
O  
P

CONTENTS

<b>PRECAUTION</b> .....	2	Exploded View .....	11
<b>PRECAUTIONS</b> .....	2	Removal and Installation .....	11
Precaution for Supplemental Restraint System (SRS) "AIR BAG" and "SEAT BELT PRE-TENSIONER" .....	2	<b>SPIRAL CABLE</b> .....	14
Precautions Necessary for Steering Wheel Rotation After Battery Disconnection .....	2	Exploded View .....	14
Service .....	3	Removal and Installation .....	14
<b>PREPARATION</b> .....	4	<b>PASSENGER AIR BAG MODULE</b> .....	17
<b>PREPARATION</b> .....	4	Exploded View .....	17
Commercial Service Tools .....	4	Removal and Installation .....	17
<b>BASIC INSPECTION</b> .....	5	<b>CURTAIN AIR BAG MODULE</b> .....	19
<b>COLLISION DIAGNOSIS</b> .....	5	Exploded View .....	19
<b>FOR FRONTAL COLLISION</b> .....	5	Removal and Installation .....	19
FOR FRONTAL COLLISION : When SRS is activated in a collision .....	5	<b>CRASH ZONE SENSOR</b> .....	21
FOR FRONTAL COLLISION : When SRS is not activated in a collision .....	6	Exploded View .....	21
<b>FOR SIDE AND ROLLOVER COLLISION</b> .....	7	Removal and Installation .....	21
FOR SIDE AND ROLLOVER COLLISION : When SRS is activated in a collision .....	7	<b>SATELLITE SENSOR</b> .....	23
FOR SIDE AND ROLLOVER COLLISION : When SRS is not activated in a collision .....	8	Exploded View .....	23
<b>REMOVAL AND INSTALLATION</b> .....	11	Removal and Installation .....	23
<b>DRIVER AIR BAG MODULE</b> .....	11	<b>DIAGNOSIS SENSOR UNIT</b> .....	25
		Exploded View .....	25
		Removal and Installation .....	25
		<b>SEAT BELT PRE-TENSIONER</b> .....	27
		Removal and Installation .....	27
		<b>OCCUPANT DETECTION SYSTEM CONTROL UNIT</b> .....	28
		Exploded View .....	28
		Removal and Installation .....	28

# PRECAUTIONS

< PRECAUTION >

## PRECAUTION

### PRECAUTIONS

#### Precaution for Supplemental Restraint System (SRS) "AIR BAG" and "SEAT BELT PRE-TENSIONER"

INFOID:000000006562522

The Supplemental Restraint System such as "AIR BAG" and "SEAT BELT PRE-TENSIONER", used along with a front seat belt, helps to reduce the risk or severity of injury to the driver and front passenger for certain types of collision. This system includes seat belt switch inputs and dual stage front air bag modules. The SRS system uses the seat belt switches to determine the front air bag deployment, and may only deploy one front air bag, depending on the severity of a collision and whether the front occupants are belted or unbelted. Information necessary to service the system safely is included in the "SRS AIR BAG" and "SEAT BELT" of this Service Manual.

#### **WARNING:**

Always observe the following items for preventing accidental activation.

- To avoid rendering the SRS inoperative, which could increase the risk of personal injury or death in the event of a collision that would result in air bag inflation, all maintenance must be performed by an authorized NISSAN/INFINITI dealer.
- Improper maintenance, including incorrect removal and installation of the SRS, can lead to personal injury caused by unintentional activation of the system. For removal of Spiral Cable and Air Bag Module, see "SRS AIR BAG".
- Never use electrical test equipment on any circuit related to the SRS unless instructed to in this Service Manual. SRS wiring harnesses can be identified by yellow and/or orange harnesses or harness connectors.

#### PRECAUTIONS WHEN USING POWER TOOLS (AIR OR ELECTRIC) AND HAMMERS

#### **WARNING:**

Always observe the following items for preventing accidental activation.

- When working near the Air Bag Diagnosis Sensor Unit or other Air Bag System sensors with the ignition ON or engine running, never use air or electric power tools or strike near the sensor(s) with a hammer. Heavy vibration could activate the sensor(s) and deploy the air bag(s), possibly causing serious injury.
- When using air or electric power tools or hammers, always switch the ignition OFF, disconnect the battery, and wait at least 3 minutes before performing any service.

#### Precautions Necessary for Steering Wheel Rotation After Battery Disconnection

INFOID:000000006562523

#### **CAUTION:**

Comply with the following cautions to prevent any error and malfunction.

- Before removing and installing any control units, first turn the ignition switch to the LOCK position, then disconnect both battery cables.
- After finishing work, confirm that all control unit connectors are connected properly, then re-connect both battery cables.
- Always use CONSULT to perform self-diagnosis as a part of each function inspection after finishing work. If a DTC is detected, perform trouble diagnosis according to self-diagnosis results.

For vehicle with steering lock unit, if the battery is disconnected or discharged, the steering wheel will lock and cannot be turned.

If turning the steering wheel is required with the battery disconnected or discharged, follow the operation procedure below before starting the repair operation.

#### OPERATION PROCEDURE

1. Connect both battery cables.

#### **NOTE:**

Supply power using jumper cables if battery is discharged.

2. Turn the ignition switch to ACC position.  
(At this time, the steering lock will be released.)
3. Disconnect both battery cables. The steering lock will remain released with both battery cables disconnected and the steering wheel can be turned.

# PRECAUTIONS

## < PRECAUTION >

4. Perform the necessary repair operation.
5. When the repair work is completed, re-connect both battery cables. With the brake pedal released, turn the ignition switch from ACC position to ON position, then to LOCK position. (The steering wheel will lock when the ignition switch is turned to LOCK position.)
6. Perform self-diagnosis check of all control units using CONSULT.

## Service

INFOID:000000006562525

- Never use electrical test equipment to check SRS circuits unless instructed to in this Service Manual.
- Before servicing the SRS, turn ignition switch OFF, disconnect both battery cables and wait at least 3 minutes.  
For approximately 3 minutes after the cables are removed, it is still possible for the air bag and seat belt pretensioner to deploy. Therefore, never work on any SRS connectors or wires until at least 3 minutes have elapsed.
- Diagnosis sensor unit must always be installed with their arrow marks “⇐” pointing towards the front of the vehicle for proper operation. Also check diagnosis sensor unit for cracks, deformities or rust before installation and replace as required.
- The spiral cable must be aligned in the neutral position since its rotations are limited. Never turn steering wheel and column after removal of steering gear.
- Handle air bag module carefully. Always place driver and passenger air bag modules with the pad side facing upward and seat mounted front side air bag module standing with the stud bolt side facing down.
- Conduct self-diagnosis to check entire SRS for proper functioning after replacing any components.
- After air bag inflates, the front instrument panel assembly should be replaced if damaged.
- Always replace instrument panel pad following passenger air bag deployment.

A  
B  
C  
D  
E  
F  
G  
I  
J  
K  
L  
M  
N  
O  
P

SR

# PREPARATION

< PREPARATION >

## PREPARATION

### PREPARATION

#### Commercial Service Tools

INFOID:000000006562526

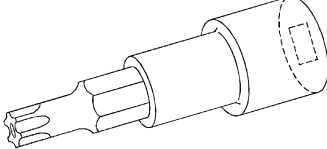
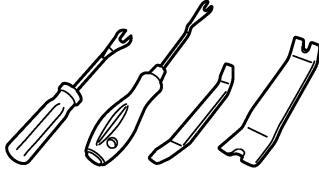
Tool name	Description
Tamper resistant TORX bit  S-NT757	Removes tool of driver air bag module and/or Diagnosis sensor unit
Remover tool  JMKIA3050ZZ	Removes clips, pawls and metal clips

# COLLISION DIAGNOSIS

< BASIC INSPECTION >

## BASIC INSPECTION

### COLLISION DIAGNOSIS FOR FRONTAL COLLISION

FOR FRONTAL COLLISION : When SRS is activated in a collision

INFOID:000000006562527

**CAUTION:**

**Due to varying models and option levels, not all parts listed in the chart below apply to all vehicles.**

**WORK PROCEDURE**

1. Before performing any of the following steps, ensure that all vehicle body and structural repairs have been completed.
2. Replace the diagnosis sensor unit.
3. Remove the front air bag modules, crash zone sensor, bracket and seat belt pre-tensioner assemblies.
4. Check the SRS components using the table below:  
Replace any SRS components showing visible signs of damage. (dents, cracks and deformation, etc.)
5. Install new front air bag modules, crash zone sensor assembly, bracket and seat belt pre-tensioner assemblies.
6. Perform self-diagnosis using CONSULT or air bag warning lamp. Refer to [SRC-17, "Diagnosis Description"](#) for details. Ensure entire SRS operates properly.
7. After the work is completed, perform self-diagnosis to check that no malfunction is detected. Refer to [SRC-17, "Diagnosis Description"](#).

**SRS INSPECTION (FOR FRONTAL COLLISION)**

Part	Inspection
Driver air bag module	If the driver air bag has deployed: <b>REPLACE</b> Install with new fasteners.
Passenger air bag module (if equipped)	If the passenger air bag has deployed: <b>REPLACE</b> Install with new fasteners.
Crash zone sensor	If any of the front air bags or seat belt pre-tensioners* have been activated: <b>REPLACE</b> the crash zone sensor and bracket with new fasteners. *: Confirm seat belt pre-tensioner activation using CONSULT only.
Seat belt pre-tensioner assemblies (All applicable locations: buckle, retractor, lap outer)	If either the driver or passenger seat belt pre-tensioner* has been activated: <b>REPLACE</b> all seat belt pre-tensioner assemblies with new fasteners. *: Confirm seat belt pre-tensioner activation using CONSULT only.
Diagnosis sensor unit	If any of the SRS components have been activated: <b>REPLACE</b> the diagnosis sensor unit. Install with new fasteners.
Steering wheel	<ol style="list-style-type: none"> <li>1. Visually check steering wheel for deformities.</li> <li>2. Check harness (built into steering wheel) and connectors for damage, and terminals for deformities.</li> <li>3. Install driver air bag module into the steering wheel to check fit and alignment with the wheel.</li> <li>4. Check steering wheel for excessive free play.</li> <li>5. If no damage is found, reinstall.</li> <li>6. If damaged – <b>REPLACE</b>.</li> </ol>
Spiral cable	If the driver front air bag has deployed: <b>REPLACE</b> the spiral cable.
Occupant classification system (Passenger seat)	<ol style="list-style-type: none"> <li>1. Remove passenger seat assembly.</li> <li>2. Check control unit case for dents, cracks or deformities.</li> <li>3. Check connectors and pressure sensor tube for damage, and terminals for deformities.</li> <li>4. Check seat frame and cushion pan for dents or deformities.</li> <li>5. If no damage is found, reinstall seat with new fasteners.</li> <li>6. If damaged – <b>REPLACE</b> seat cushion assembly with new fasteners.</li> </ol>

# COLLISION DIAGNOSIS

## < BASIC INSPECTION >

Part	Inspection
Harness and connectors	<ol style="list-style-type: none"> <li>1. Check connectors for poor connection, damage, and terminals for deformities.</li> <li>2. Check harness for binding, chafing, cuts, or deformities.</li> <li>3. If no damage is found, reinstall the harness and connectors.</li> <li>4. If damaged – REPLACE the damaged harness. Do not attempt to repair, splice or modify any SRS harness.</li> </ol>
Instrument panel assembly	If the passenger air bag has deployed: REPLACE the instrument panel assembly. (integrated type)

## FOR FRONTAL COLLISION : When SRS is not activated in a collision

INFOID:000000006562528

### CAUTION:

**Due to varying models and option levels, not all parts listed in the chart below apply to all vehicles.**

### WORK PROCEDURE

1. Before performing any of the following steps, ensure that all vehicle body and structural repairs have been completed.
2. Check the SRS components using the table below:  
Replace any SRS components showing visible signs of damage. (dents, cracks and deformation, etc.)
3. Perform self-diagnosis using CONSULT or air bag warning lamp. Refer to [SRC-17, "Diagnosis Description"](#) for details. Ensure entire SRS operates properly.
4. After the work is completed, perform self-diagnosis to check that no malfunction is detected. Refer to [SRC-17, "Diagnosis Description"](#).

### SRS INSPECTION (FOR FRONTAL COLLISION)

Part	Inspection
Driver air bag module	<p>If the driver air bag has NOT been deployed:</p> <ol style="list-style-type: none"> <li>1. Remove driver air bag module. Check harness cover and connectors for damage, terminals for deformities, and harness for binding.</li> <li>2. Install driver air bag module into the steering wheel to check fit and alignment with the wheel.</li> <li>3. If no damage is found, reinstall with new fasteners.</li> <li>4. If damaged – REPLACE. Install driver air bag module with new fasteners.</li> </ol>
Passenger air bag module (if equipped)	<p>If the passenger air bag has NOT been deployed:</p> <ol style="list-style-type: none"> <li>1. Remove passenger air bag module. Check harness cover and connectors for damage, terminals for deformities, and harness for binding.</li> <li>2. Install passenger air bag module into the instrument panel to check fit with the instrument panel.</li> <li>3. If no damage is found, reinstall with new fasteners.</li> <li>4. If damaged – REPLACE. Install passenger air bag modules with new fasteners.</li> </ol>
Crash zone sensor	<p>If the front air bags or seat belt pre-tensioners have NOT been activated:</p> <ol style="list-style-type: none"> <li>1. Remove the crash zone sensor. Check harness connectors for damage, terminals for deformities, and harness for binding.</li> <li>2. Check for visible signs of damage (dents, cracks, deformation, etc.) of the crash zone sensor and bracket.</li> <li>3. Install the crash zone sensor to check fit.</li> <li>4. If no damage is found, reinstall with new fasteners.</li> <li>5. If damaged – REPLACE the crash zone sensor and bracket with new fasteners.</li> </ol>
Seat belt pre-tensioner assemblies (All applicable locations: buckle, retractor, lap outer)	<p>If the pre-tensioners have NOT been activated:</p> <ol style="list-style-type: none"> <li>1. Remove seat belt pre-tensioners. Check harness cover and connectors for damage, terminals for deformities, and harness for binding.</li> <li>2. Check belts for damage and anchors for loose mounting.</li> <li>3. Check retractor for smooth operation.</li> <li>4. Check seat belt adjuster for damage.</li> <li>5. Check for deformities of the center pillar inner.</li> <li>6. If the center pillar inner has no damage, REPLACE the seat belt pre-tensioner assembly.</li> <li>7. If no damage is found, reinstall seat belt pre-tensioner assembly.</li> <li>8. If damaged – REPLACE. Install the seat belt pre-tensioners with new fasteners.</li> </ol>

# COLLISION DIAGNOSIS

## < BASIC INSPECTION >

Part	Inspection
Diagnosis sensor unit	If none of the SRS components have been activated: 1. Check case for dents, cracks or deformities. 2. Check connectors for damage, and terminals for deformities. 3. If no damage is found, reinstall with new fasteners. 4. If damaged – REPLACE. Install diagnosis sensor unit with new fasteners.
Steering wheel	1. Visually check steering wheel for deformities. 2. Check harness (built into steering wheel) and connectors for damage, and terminals for deformities. 3. Install driver air bag module into the steering wheel to check fit and alignment with the wheel. 4. Check steering wheel for excessive free play. 5. If no damage is found, reinstall. 6. If damaged – REPLACE.
Spiral cable	If the driver front air bag has not deployed: 1. Visually check spiral cable and combination switch for damage. 2. Check connectors and protective tape for damage. 3. Check steering wheel for noise, binding or heavy operation. 4. If no damage is found, reinstall. 5. If damaged – REPLACE.
Occupant classification system (Passenger seat)	1. Remove passenger seat assembly. 2. Check control unit case for dents, cracks or deformities. 3. Check connectors and pressure sensor tube for damage, and terminals for deformities. 4. Check seat frame and cushion pan for dents or deformities. 5. If no damage is found, reinstall seat with new fasteners. 6. If damaged – REPLACE seat cushion assembly with new fasteners.
Harness and connectors	1. Check connectors for poor connection, damage, and terminals for deformities. 2. Check harness for binding, chafing, cuts, or deformities. 3. If no damage is found, reinstall the harness and connectors. 4. If damaged – REPLACE the damaged harness. Do not attempt to repair, splice or modify any SRS harness.
Instrument panel assembly	If the passenger air bag has NOT deployed: 1. Visually check instrument panel assembly for damage. 2. If no damage is found, reinstall the instrument panel assembly. 3. If damaged – REPLACE the instrument panel assembly.

A  
B  
C  
D  
E  
F  
G  
SR  
I  
J

## FOR SIDE AND ROLLOVER COLLISION

### FOR SIDE AND ROLLOVER COLLISION : When SRS is activated in a collision

INFOID:000000006562529

#### **CAUTION:**

**Due to varying models and option levels, not all parts listed in the chart below apply to all vehicles.**

#### WORK PROCEDURE

1. Before performing any of the following steps, ensure that all vehicle body and structural repairs have been completed.
2. Replace the following components:
  - Front seat back assembly (on the side on which side air bag is activated)
  - Door finisher (on the side on which door-mounted curtain air bag is activated)
  - Pop-up roll bar assemblies and pop-up roll bar covers
  - Satellite sensor LH/RH (on the side on which side air bag is activated)
  - Diagnosis sensor unit
  - Seat belt pre-tensioner assemblies
3. Check the SRS components and the related parts using the following table. Replace any SRS components and the related parts showing visible signs of damage. (dents, cracks, deformation, etc.)
4. Perform self-diagnosis using CONSULT and “AIR BAG” warning lamp. Refer to [SRC-17, "Diagnosis Description"](#) for details. Make sure entire SRS operates properly.
5. After the work is completed, perform self-diagnosis to check that no malfunction is detected. Refer to [SRC-17, "Diagnosis Description"](#).

K  
L  
M  
N  
O  
P

# COLLISION DIAGNOSIS

## < BASIC INSPECTION >

### SRS INSPECTION (FOR SIDE AND ROLLOVER COLLISION)

Part	Inspection
Curtain air bag module LH	If the curtain air bag LH has deployed: REPLACE the curtain air bag module LH. Install with new fasteners.
Curtain air bag module RH	If the curtain air bag RH has deployed: REPLACE the curtain air bag module RH. Install with new fasteners.
Front side air bag module LH	If the front side air bag LH has deployed: REPLACE front seatback assembly LH.
Front side air bag module RH	If the front side air bag RH has deployed: REPLACE front seatback assembly RH.
Satellite sensor (LH or RH)	If any of the SRS components have deployed: REPLACE the satellite sensor on the collision side with new fasteners.
Diagnosis sensor unit	If any of the SRS components have deployed: REPLACE the diagnosis sensor unit with new fasteners.
Seat belt pre-tensioner assemblies (All applicable locations: buckle, retractor, lap outer)	If either the driver or passenger seat belt pre-tensioner* has been activated: REPLACE all seat belt pre-tensioner assemblies with new fasteners. *: Confirm seat belt pre-tensioner activation using CONSULT only.
Center inner pillar	1. Check the center inner pillar on the collision side for damage (dents, cracks, deformation, etc.). 2. If damaged – REPAIR the center inner pillar.
Trim/headlining	1. Check for visible signs of damage (dents, cracks, deformation, etc.) of the interior trim on the collision side. 2. If damaged – REPLACE the damaged trim parts.
Door-mounted curtain air bag module LH	If the door-mounted curtain air bag module LH has deployed: REPLACE the door finisher LH and door-mounted curtain air bag module. Install with new fasteners.
Door-mounted curtain air bag module RH	If the door-mounted curtain air bag module RH has deployed: REPLACE the door finisher RH and door-mounted curtain air bag module. Install with new fasteners.
Pop-up roll bar assemblies	If the pop-up roll bar has deployed: REPLACE pop-up roll bar assemblies and pop-up roll bar covers. Install with new fasteners.

### FOR SIDE AND ROLLOVER COLLISION : When SRS is not activated in a collision

INFOID:000000006562530

#### **CAUTION:**

**Due to varying models and option levels, not all parts listed in the chart below apply to all vehicles.**

#### WORK PROCEDURE

1. Before performing any of the following steps, ensure that all vehicle body and structural repairs have been completed.
2. Check the SRS components and the related parts using the following table.
  - If the front seat back assembly is damaged, the front seat back assembly must be replaced.
  - If the door finisher assembly is damaged, the door finisher assembly and door-mounted curtain air bag module must be replaced.
3. Perform self-diagnosis using CONSULT and “AIR BAG” warning lamp. Refer to [SRC-17. "Diagnosis Description"](#) for details. Make sure entire SRS operates properly.
4. After the work is completed, perform self-diagnosis to check that no malfunction is detected. Refer to [SRC-17. "Diagnosis Description"](#).

### SRS INSPECTION (FOR SIDE AND ROLLOVER COLLISION)



# COLLISION DIAGNOSIS

## < BASIC INSPECTION >

Part	Inspection	
Curtain air bag module LH	If the curtain air bag LH has NOT deployed: 1. Check for visible signs of damage (dents, tears, deformation, etc.) of the center pillar on the collision side. 2. If damaged – Remove the curtain air bag module LH. 3. Check for visible signs of damage (tears etc.) of the curtain air bag module LH. 4. Check harness and connectors for damage, and terminals for deformities. 5. If no damage is found, reinstall the curtain air bag module LH with new fasteners. 6. If damaged – REPLACE the curtain air bag module LH with new fasteners.	A B C
Curtain air bag module RH	If the curtain air bag RH has NOT deployed: 1. Check for visible signs of damage (dents, tears, deformation, etc.) of the center pillar on the collision side. 2. If damaged – Remove the curtain air bag module RH. 3. Check for visible signs of damage (tears etc.) of the curtain air bag module RH. 4. Check harness and connectors for damage, and terminals for deformities. 5. If no damage is found, reinstall the curtain air bag module RH with new fasteners. 6. If damaged – REPLACE the curtain air bag module RH with new fasteners.	D E
Front side air bag module LH	If the front side air bag LH has NOT deployed: 1. Check for visible signs of damage (dents, tears, deformation, etc.) of the seat back on the collision side. 2. Check harness and connectors for damage, and terminals for deformities. 3. If damaged – REPLACE the front seatback assembly LH.	F
Front side air bag module RH	If the front side air bag RH has NOT deployed: 1. Check for visible signs of damage (dents, tears, deformation, etc.) of the seat back on the collision side. 2. Check harness and connectors for damage, and terminals for deformities. 3. If damaged – REPLACE the front seatback assembly RH.	G <b>SR</b>
Satellite sensor (LH or RH)	If none of the SRS components have been activated: 1. Remove the satellite sensor (LH or RH) on the collision side. Check harness connectors for damage, terminals for deformities, and harness for binding. 2. Check for visible signs of damage (dents, cracks, deformation, etc.) of the satellite sensor (LH or RH). 3. Install the satellite sensor (LH or RH) to check fit. 4. If no damage is found, reinstall the satellite sensor (LH or RH) with new fasteners. 5. If damaged – REPLACE the satellite sensor (LH or RH) with new fasteners.	I J
Diagnosis sensor unit	If none of the SRS components have been activated: 1. Check case and bracket for dents, cracks or deformities. 2. Check connectors for damage, and terminals for deformities. 3. If no damage is found, reinstall the diagnosis sensor unit with new fasteners. 4. If damaged – REPLACE the diagnosis sensor unit with new fasteners.	K L
Seat belt pre-tensioner assemblies (All applicable locations: buckle, retractor, lap outer)	If the pre-tensioners have NOT been activated: 1. Remove seat belt pre-tensioners. Check harness cover and connectors for damage, terminals for deformities, and harness for binding. 2. Check belts for damage and anchors for loose mounting. 3. Check retractor for smooth operation. 4. Check seat belt adjuster for damage. 5. Check for deformities of the center pillar inner. 6. If the center pillar inner has no damage, REPLACE the seat belt pre-tensioner assembly. 7. If no damage is found, reinstall seat belt pre-tensioner assembly. 8. If damaged – REPLACE. Install the seat belt pre-tensioners with new fasteners.	M N O
Seat (with front side air bag)	If the front LH or front RH side air bag modules have NOT deployed: 1. Visually check the seat on the collision side. 2. Remove the seat on the collision side and check the following for damage and deformities. - Harness, connectors and terminals - Frame and recliner (for front and rear seat), and also adjuster and slides (for front seat) 3. If no damage is found, reinstall the seat. 4. If damaged – REPLACE the damaged seat parts using new fasteners. If the front seat back is damaged, the front seat back assembly must be replaced.	P
Center inner pillar	1. Check the center inner pillar on the collision side for damage (dents, cracks, deformation, etc.). 2. If damaged – REPAIR the center inner pillar.	

# COLLISION DIAGNOSIS

## < BASIC INSPECTION >

Part	Inspection
Trim/headlining	<ol style="list-style-type: none"> <li>1. Check for visible signs of damage (dents, cracks, deformation, etc.) of the interior trim on the collision side.</li> <li>2. If damaged – REPLACE the damaged trim parts.</li> </ol>
Door-mounted curtain air bag module LH	<p>If the door-mounted curtain air bag LH has NOT deployed:</p> <ol style="list-style-type: none"> <li>1. Check for visible signs of damage (dents, tears, deformation, etc.) of the door finisher on the collision side.</li> <li>2. If damaged – REPLACE the door finisher LH with new fasteners.</li> <li>3. Check for visible signs of damaged (tears etc.) of the door-mounted curtain air bag module LH.</li> <li>4. Check harness and connectors for damage, and terminals for deformities.</li> <li>5. If no damage is found, reinstall door finisher. <b>CAUTION:</b> <b>When removing door-mounted curtain air bag module from door finisher, never reuse door finisher.</b></li> <li>6. If damaged – REPLACE the door finisher LH and door-mounted curtain air bag module LH with new fasteners.</li> </ol>
Door-mounted curtain air bag module RH	<p>If the door-mounted curtain air bag RH has NOT deployed:</p> <ol style="list-style-type: none"> <li>1. Check for visible signs of damage (dents, tears, deformation, etc.) of the door finisher on the collision side.</li> <li>2. If damaged – REPLACE the door finisher RH with new fasteners.</li> <li>3. Check for visible signs of damage (tears etc.) of the door-mounted curtain air bag module RH.</li> <li>4. Check harness and connectors for damage, and terminals for deformities.</li> <li>5. If no damage is found, reinstall door finisher. <b>CAUTION:</b> <b>When removing door-mounted curtain air bag module from door finisher, never reuse door finisher.</b></li> <li>6. If damaged – REPLACE the door finisher RH and door-mounted curtain air bag module RH with new fasteners.</li> </ol>
Pop-up roll bar	<p>If the pop-up roll bar has NOT deployed:</p> <ol style="list-style-type: none"> <li>1. Check for visible signs of damage (dents, tears, deformation, etc.) of the pop-up roll bar.</li> <li>2. If damaged – REPLACE the pop-up roll bar with new fasteners.</li> <li>3. Check harness and connectors for damage, and terminals for deformities.</li> <li>4. If no damage is found, reinstall the pop-up roll bar with new fasteners.</li> <li>5. Check for visible signs of damage (dents, cracks, deformation, etc.) of the seatback support brace assembly.</li> <li>6. If damaged – REPAIR the seatback support brace assembly.</li> </ol>

# DRIVER AIR BAG MODULE

< REMOVAL AND INSTALLATION >

## REMOVAL AND INSTALLATION

### DRIVER AIR BAG MODULE

Exploded View

INFOID:000000006562531

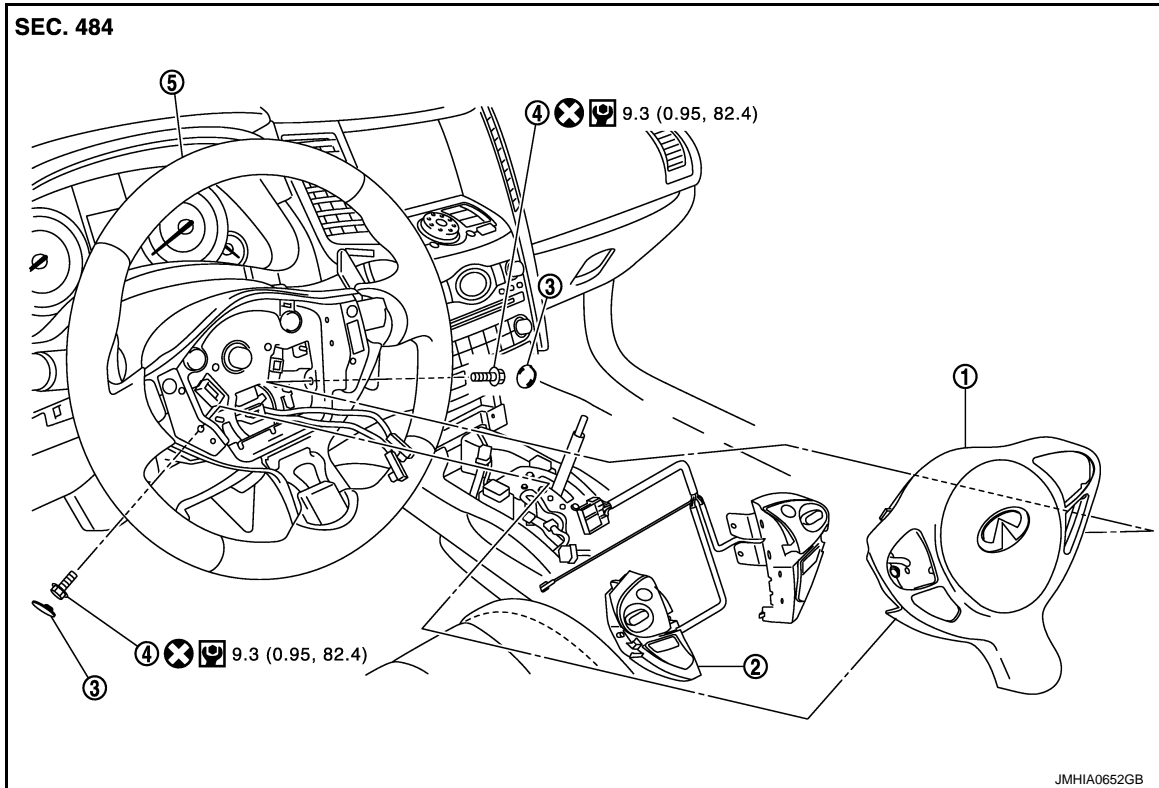

- |                          |                    |                     |
|--------------------------|--------------------|---------------------|
| 1. Driver air bag module | 2. Steering switch | 3. Side lid (LH/RH) |
| 4. TORX bolt (LH/RH)     | 5. Steering wheel  |                     |

⊗ : Always replace after every disassembly.

9.3 : N·m (kg·m, in·lb)

### Removal and Installation

INFOID:000000006562532

#### **WARNING:**

- Before servicing, turn ignition switch OFF, disconnect battery negative terminal and wait 3 minutes or more.
- Always work from the side of air bag module. Never work in front of it.
- Never use the air tools or the electric tools for servicing.

#### REMOVAL

1. Remove the side lids (LH/RH).

# DRIVER AIR BAG MODULE

## < REMOVAL AND INSTALLATION >

2. Remove the driver air bag module mounting TORX bolt (LH/RH) with TORX bit (A).

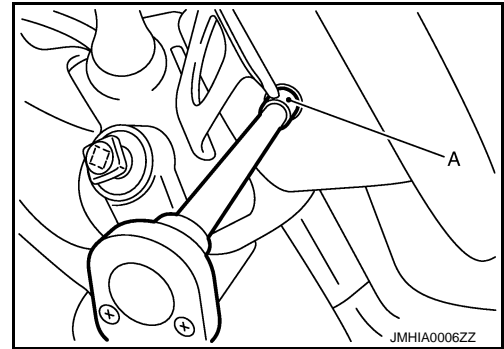

3. Pull out the driver air bag module assembly.
4. Disconnect the driver air bag module harness connector.

### CAUTION:

- For installing/removing the driver air bag module harness connector, insert thin screwdriver wrapped in tape into notch, lift lock and remove connector.
- Install connector with lock raised, and push lock into connector.
- After installing the connector, check that the lock is pushed securely into it.

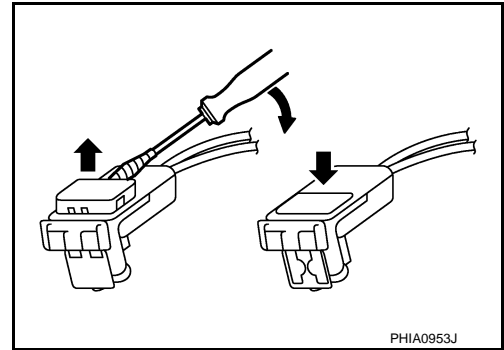

5. Remove the driver air bag module assembly.

### CAUTION:

- Always place the driver air bag module with pad side facing upward.

↕ : Upward

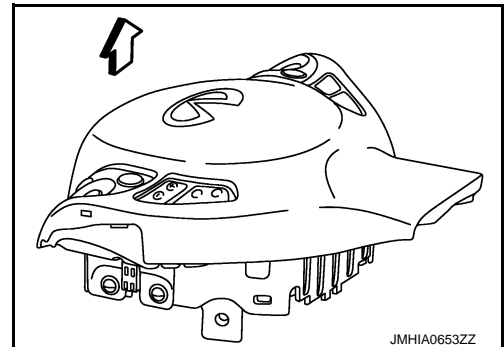

- Never impact the driver air bag module.
- Replace the driver air bag module if it has been dropped or sustained an impact.



- Never insert any foreign objects (screwdriver, etc.) into the driver air bag module.
- Never disassemble the driver air bag module.
- Never expose the driver air bag module to temperatures exceeding 90°C (194°F).
- Never allow oil, grease, detergent, or water to come in contact with the driver air bag module.

## INSTALLATION

Note the following items, and then install in the reverse order of removal.

## DRIVER AIR BAG MODULE

### < REMOVAL AND INSTALLATION >

#### CAUTION:

- Never use the old TORX bolts after removal, replace with the new bolts.
- Fix the driver air bag module harness to the harness fixing hook (A).

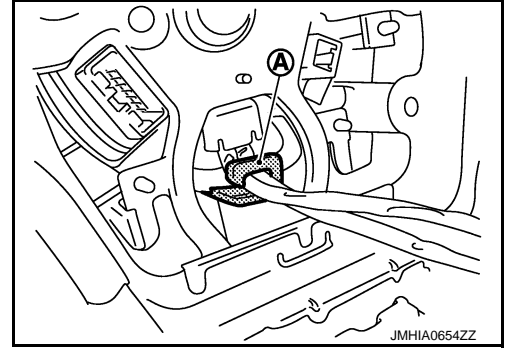

- Never damage the harness while installing.
- Tighten the TORX bolts after completely adjusting the centers of fixing holes on the driver air bag module side and the steering wheel side. If the holes are misaligned, the bolt threads are damaged and the module is not installed securely.
- If malfunction is detected by the air bag warning lamp, after repair or replacement of the malfunctioning parts, reset the memory using self-diagnosis or CONSULT. Refer to [SRC-21. "CONSULT-III Function"](#).
- After the work is completed, check that no system malfunction is detected by air bag warning lamp.

A  
B  
C  
D  
E  
F  
G  
I  
J  
K  
L  
M  
N  
O  
P

SR

# SPIRAL CABLE

< REMOVAL AND INSTALLATION >

## SPIRAL CABLE

Exploded View

INFOID:000000006562533

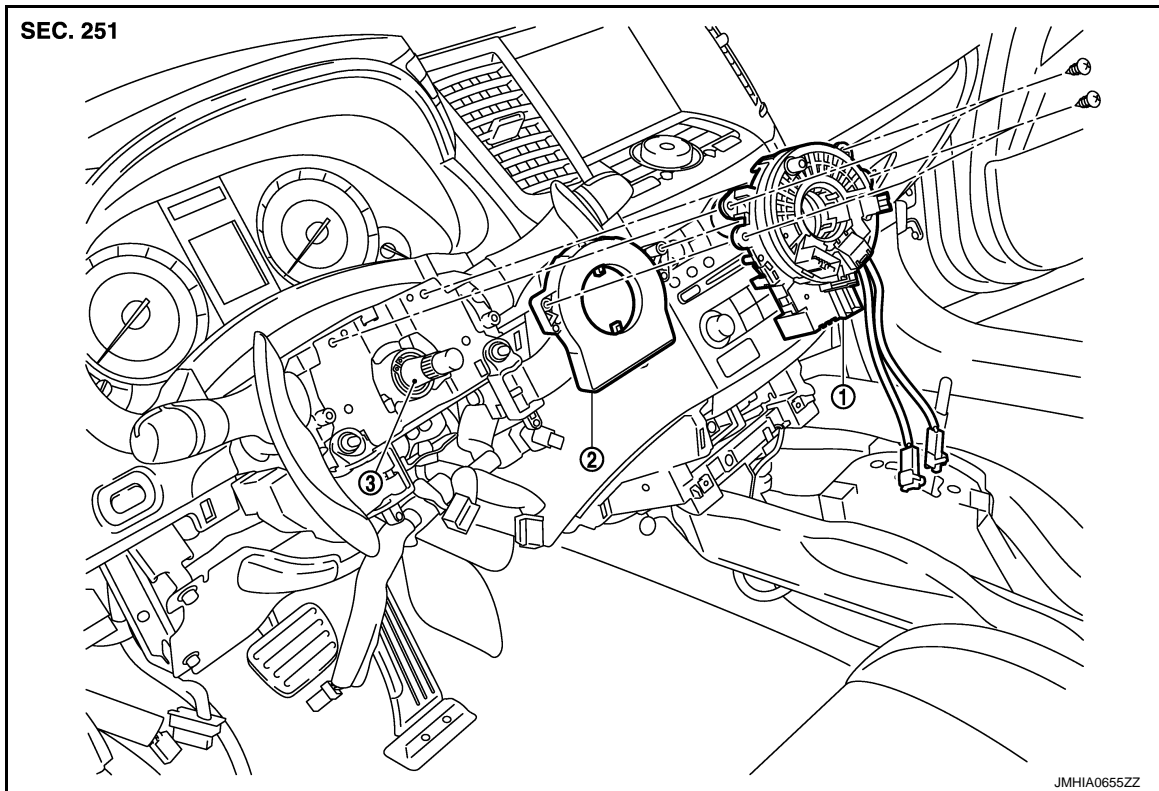

1. Spiral cable

2. Steering angle sensor

3. Steering column assembly

## Removal and Installation

INFOID:000000006562534

### WARNING:

- Before servicing, turn ignition switch OFF, disconnect battery negative terminal and wait 3 minutes or more.
- Never use the air tools or the electric tools for servicing.

### REMOVAL

1. Remove the driver air bag module. Refer to [SR-11, "Removal and Installation"](#).
2. Remove the steering wheel. Refer to [ST-17, "Removal and Installation"](#).
3. Remove the steering column cover. Refer to [IP-12, "Exploded View"](#).
4. Disconnect the spiral cable body side harness connectors (A) and the steering angle sensor harness connector (B).

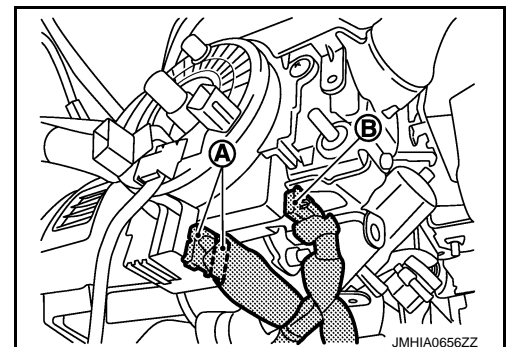

5. Remove the spiral cable fixing screws.

# SPIRAL CABLE

## < REMOVAL AND INSTALLATION >

6. Remove the spiral cable side pawls (LH/RH) with flat-bladed screw driver (A).

 : Pawl

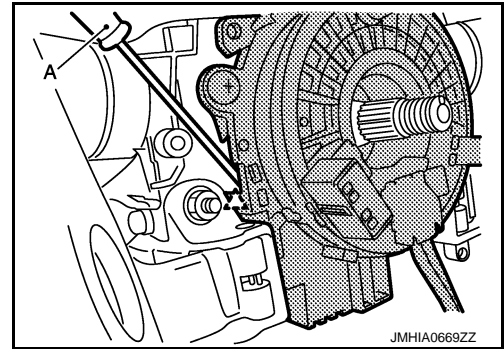

7. Pull the spiral cable and steering angle sensor out forward.

### CAUTION:

- Never impact the spiral cable.
- Replace the spiral cable if it has been dropped or sustained an impact.



- Never disassemble the spiral cable.
- Never apply lubricant to the spiral cable.
- Never allow oil, grease, detergent, or water to come in contact with the spiral cable.

## INSTALLATION

Note the following items, and then install in the reverse order of removal.

### CAUTION:

- The spiral cable may snap during steering operation if the cable is installed in an improper position. The neutral position is set as per the following.
- Carefully turn the spiral cable clockwise to the end position. Then turn it counterclockwise (about 2 and a half turns) and stop turning at the mark (B) on which the stopper insertion holes are in the same position.
- The service part is installed in the neutral position by the stopper and can be set without adjusting after the stopper is removed.
- Never over turn the spiral cable or go beyond the number of turns required. (This will cause the cable to snap)
- Adjust the spiral cable locating pin (A) to the steering wheel locating pin hole (C).

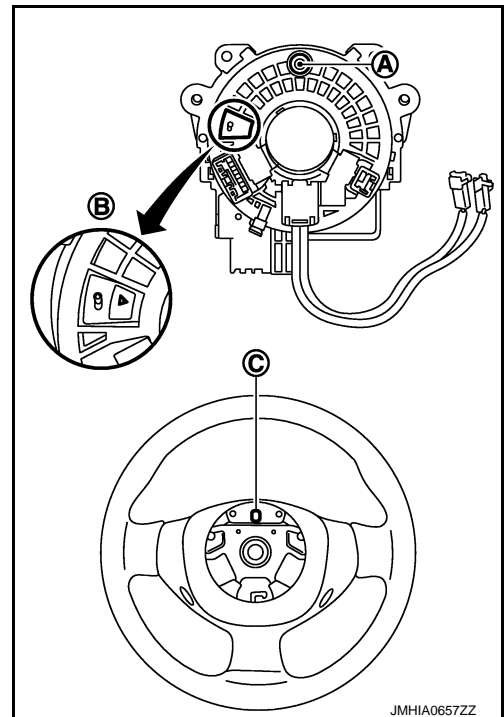

## SPIRAL CABLE

### < REMOVAL AND INSTALLATION >

---

- If malfunction is detected by the air bag warning lamp, after repair or replacement of the malfunctioning parts, reset the memory using self-diagnosis or CONSULT. Refer to [SRC-21, "CONSULT-III Function"](#).
- After the work is completed, check that no system malfunction is detected by air bag warning lamp.



# PASSENGER AIR BAG MODULE

< REMOVAL AND INSTALLATION >

## PASSENGER AIR BAG MODULE

Exploded View

INFOID:000000006562535

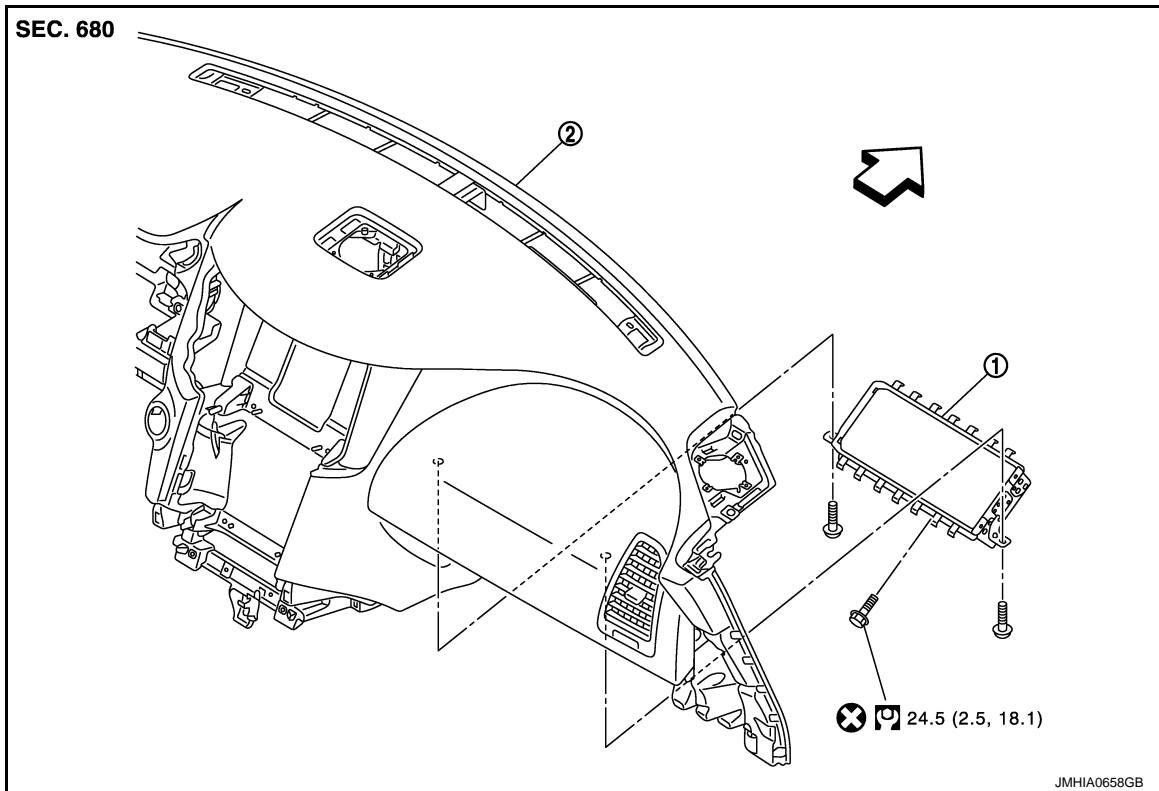

1. Passenger air bag module      2. Instrument panel assembly

← : Vehicle front

⊗ : Always replace after every disassembly.

⌚ : N·m (kg·m, ft·lb)

## Removal and Installation

INFOID:000000006562536

### WARNING:

- Before servicing, turn ignition switch OFF, disconnect battery negative terminal and wait 3 minutes or more.
- Always work from the side of air bag module. Never work in front of it.
- Never use the air tools or the electric tools for servicing.

### REMOVAL

1. Remove the instrument panel assembly. Refer to [IP-13, "Removal and Installation"](#).
2. Remove the passenger air bag module (1) fixing screws (A).

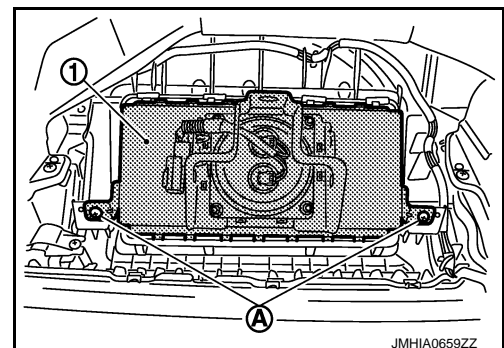

# PASSENGER AIR BAG MODULE

## < REMOVAL AND INSTALLATION >

3. Disconnect pawls by using remover tool (A), and then remove the passenger air bag module (1) from the instrument panel assembly (2).

 : Pawl

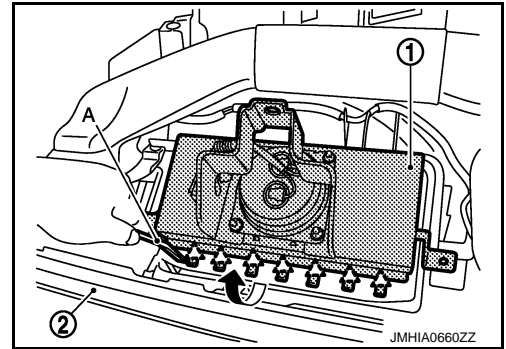

### CAUTION:

- Always place the passenger air bag module with pad side facing upward.

 : Upward

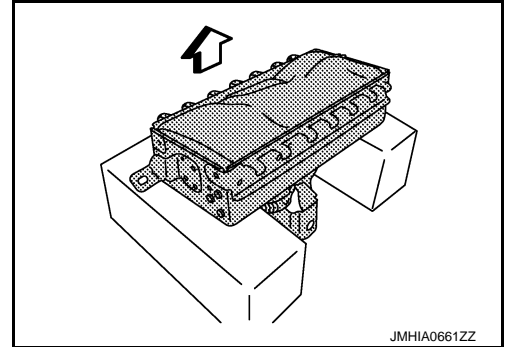

- Never impact the passenger air bag module.
- Replace the passenger air bag module if it has been dropped or sustained an impact.



- Never insert any foreign objects (screwdriver, etc.) into the passenger air bag module.
- Never disassemble the passenger air bag module.
- Never expose the passenger air bag module to temperatures exceeding 90°C (194°F).
- Never allow oil, grease, detergent, or water to come in contact with the passenger air bag module.

## INSTALLATION

Note the following items, and then install in the reverse order of removal.

### CAUTION:

- Never use the old fixing bolts after removal; replace with the new bolts.
- Never damage the harness while installing.
- If malfunction is detected by the air bag warning lamp, after repair or replacement of the malfunctioning parts, reset the memory using self-diagnosis or CONSULT. Refer to [SRC-21, "CONSULT-III Function"](#).
- After the work is completed, check that no system malfunction is detected by air bag warning lamp.

# CURTAIN AIR BAG MODULE

< REMOVAL AND INSTALLATION >

## CURTAIN AIR BAG MODULE

Exploded View

INFOID:000000006562537

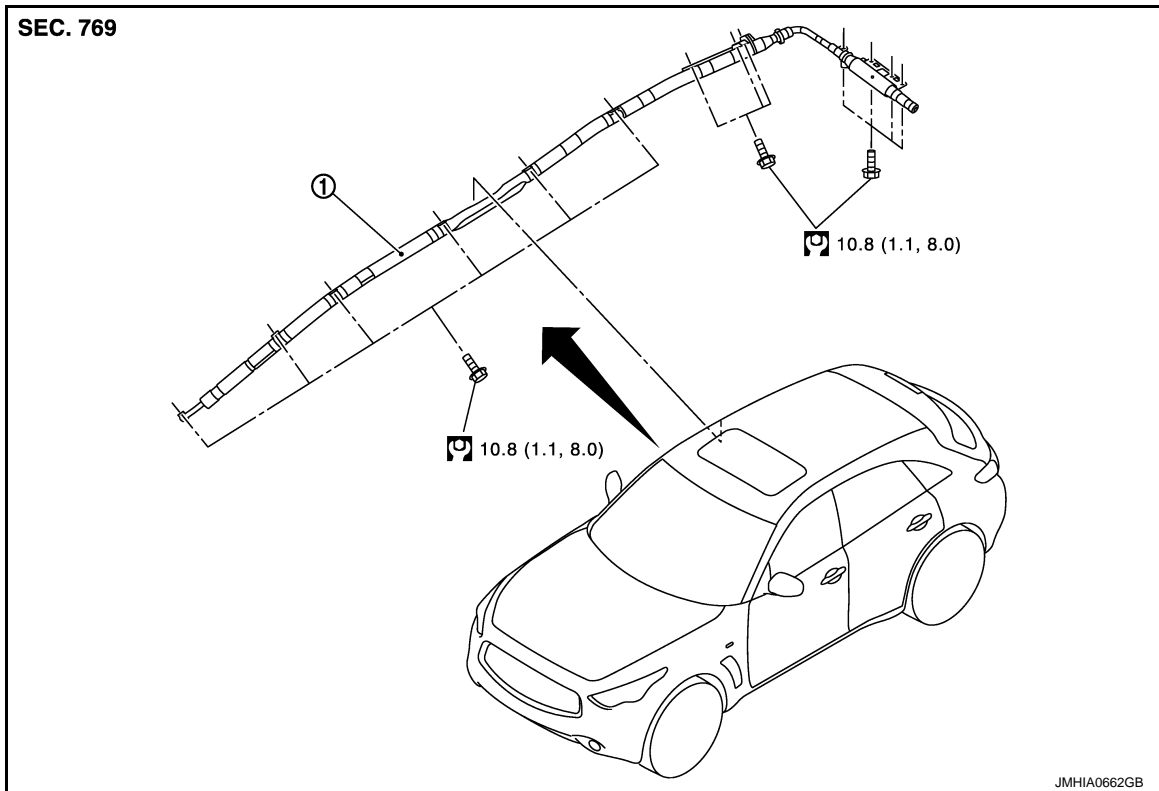

1. Curtain air bag module

 : N·m (kg-m, ft-lb)

## Removal and Installation

INFOID:000000006562538

### WARNING:

- Before servicing, turn ignition switch OFF, disconnect battery negative terminal and wait 3 minutes or more.
- Never use the air tools or the electric tools for servicing.

### REMOVAL

1. Remove the headlining. Refer to [INT-26. "Removal and Installation"](#).
2. Remove the curtain air bag module harness connector.

### CAUTION:

- For installing/removing the curtain air bag module harness connector, insert thin screwdriver wrapped in tape into notch, lift lock and remove connector.
- Install the connector with lock raised, and push lock into the connector.
- After installing the connector, check that the lock is pushed securely into it.

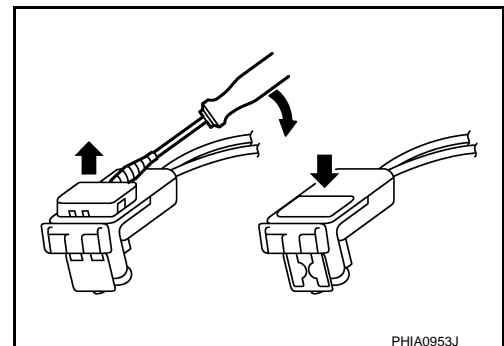

3. Remove the fixing bolts, and then remove the curtain air bag module.

### CAUTION:

A  
B  
C  
D  
E  
F  
G

SR

I

J

K

L

M

N

O

P

# CURTAIN AIR BAG MODULE

## < REMOVAL AND INSTALLATION >

- Never impact the curtain air bag module.
- Replace the curtain air bag module if it has been dropped or sustained an impact.



- Never insert any foreign objects (screwdriver, etc.) into the curtain air bag module.
- Never disassemble the curtain air bag module.
- Never expose the curtain air bag module to temperatures exceeding 90°C (194°F).
- Never allow oil, grease, detergent, or water to come in contact with the curtain air bag module.

## INSTALLATION

Note the following items, and then install in the reverse order of removal.

### CAUTION:

- Never damage the harness while installing.
- If malfunction is detected by the air bag warning lamp, after repair or replacement of the malfunctioning parts, reset the memory using self-diagnosis or CONSULT. Refer to [SRC-21, "CONSULT-III Function"](#).
- After the work is completed, check that no system malfunction is detected by air bag warning lamp.

# CRASH ZONE SENSOR

< REMOVAL AND INSTALLATION >

## CRASH ZONE SENSOR

Exploded View

INFOID:000000006562539

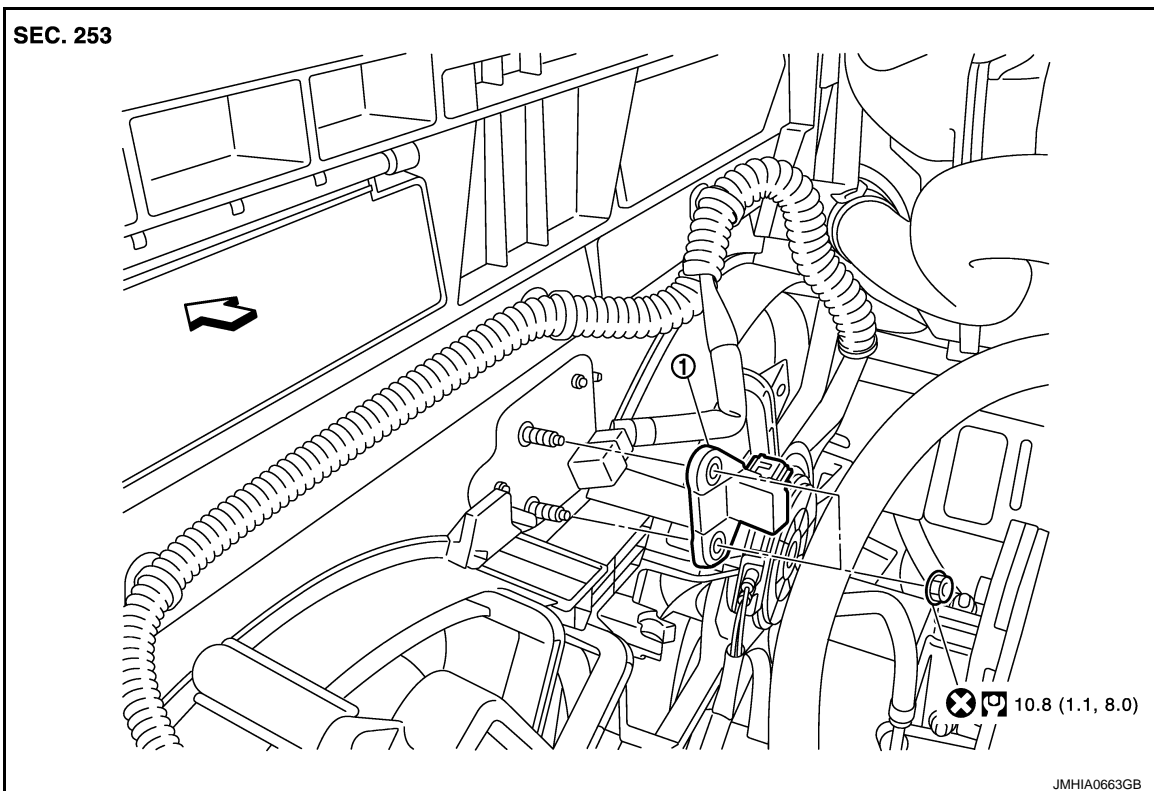

1. Crash zone sensor

↔ : Vehicle front

⊗ : Always replace after every disassembly.

⊙ : N·m (kg·m, ft·lb)

## Removal and Installation

INFOID:000000006562540

### **WARNING:**

- Before servicing, turn ignition switch OFF, disconnect battery negative terminal and wait 3 minutes or more.
- Never use the air tools or the electric tools for servicing.

### REMOVAL

1. Remove the air duct (inlet).
  - VQ35 engine: Refer to [EM-29, "Exploded View"](#).
  - VK50 engine: Refer to [EM-180, "Exploded View"](#).
2. Remove the reservoir tank.
  - VQ35 engine: Refer to [CO-14, "Exploded View"](#).
  - VK50 engine: Refer to [CO-40, "Exploded View"](#).

A  
B  
C  
D  
E  
F  
G  
SR  
I  
J  
K  
L  
M  
N  
O  
P

# CRASH ZONE SENSOR

## < REMOVAL AND INSTALLATION >

3. Disconnect crash zone sensor harness connector (A).
4. Remove the crash zone sensor (1) fixing nuts (B).

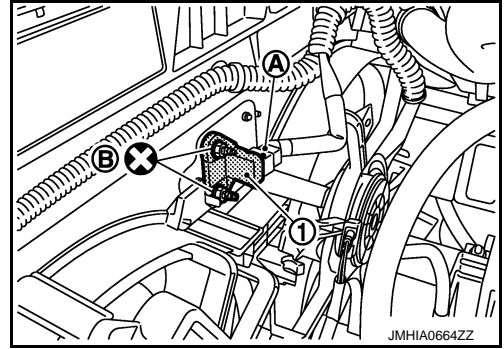

5. Remove the crash zone sensor.

### CAUTION:

- Never impact the crash zone sensor.
- Replace the crash zone sensor if it has been dropped or sustained an impact.



- Replace the crash zone sensor of deployed the driver air bag module, deployed the passenger air bag module and deployed the seat belt pre-tensioner.

## INSTALLATION

Note the following items, and then install in the reverse order of removal.

### CAUTION:

- Never use the old fixing nuts after removal, replace with the new nuts.
- Never damage the harness while installing.
- If malfunction is detected by the air bag warning lamp, after repair or replacement of the malfunctioning parts, reset the memory using self-diagnosis or CONSULT. Refer to [SRC-21. "CONSULT-III Function"](#).
- After the work is completed, check that no system malfunction is detected by air bag warning lamp.

# SATELLITE SENSOR

< REMOVAL AND INSTALLATION >

## SATELLITE SENSOR

### Exploded View

INFOID:000000006562541

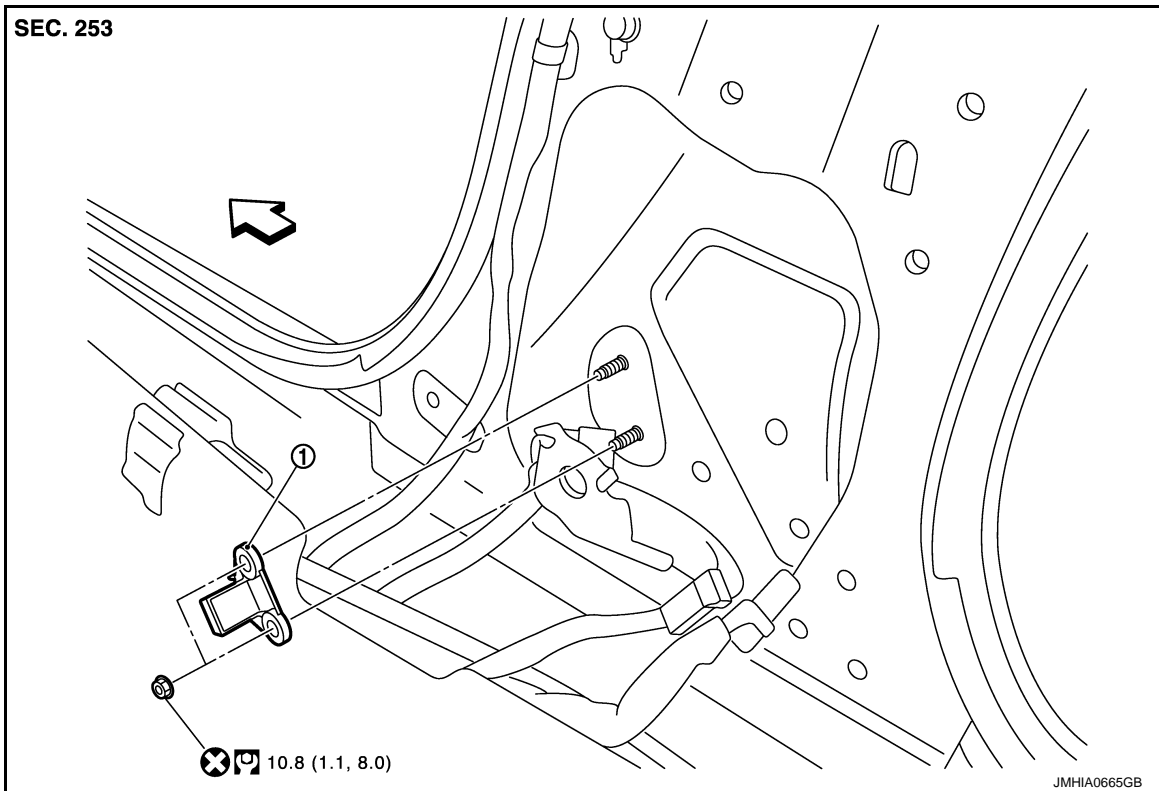

1. Satellite sensor

↔ : Vehicle front

⊗ : Always replace after every disassembly.

⊞ : N·m (kg·m, ft·lb)

### Removal and Installation

INFOID:000000006562542

#### **WARNING:**

- Before servicing, turn ignition switch OFF, disconnect battery negative terminal and wait 3 minutes or more.
- Never use the air tools or the electric tools for servicing.

#### REMOVAL

1. Remove the front seat belt retractor. Refer to [SB-6. "SEAT BELT RETRACTOR : Removal and Installation"](#).
2. Remove the satellite sensor (1) fixing nuts (B).
3. Disconnect the harness connector (A), and then remove the satellite sensor.

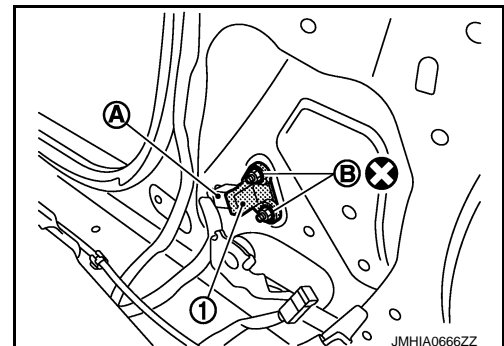

#### **CAUTION:**

## SATELLITE SENSOR

### < REMOVAL AND INSTALLATION >

- Replace the satellite sensor of deployed the side air bag module and deployed the curtain air bag module.
- Never impact the satellite sensor.
- Replace the satellite sensor if it has been dropped or sustained an impact.



### INSTALLATION

Note the following items, and then install in the reverse order of removal.

#### **CAUTION:**

- Never use the old fixing nuts after removal, replace with the new nuts.
- Never damage the harness while installing.
- If malfunction is detected by the air bag warning lamp, after repair or replacement of the malfunctioning parts, reset the memory using self-diagnosis or CONSULT. Refer to [SRC-21, "CONSULT-III Function"](#).
- After the work is completed, check that no system malfunction is detected by air bag warning lamp.



# DIAGNOSIS SENSOR UNIT

< REMOVAL AND INSTALLATION >

## DIAGNOSIS SENSOR UNIT

### Exploded View

INFOID:000000006562543

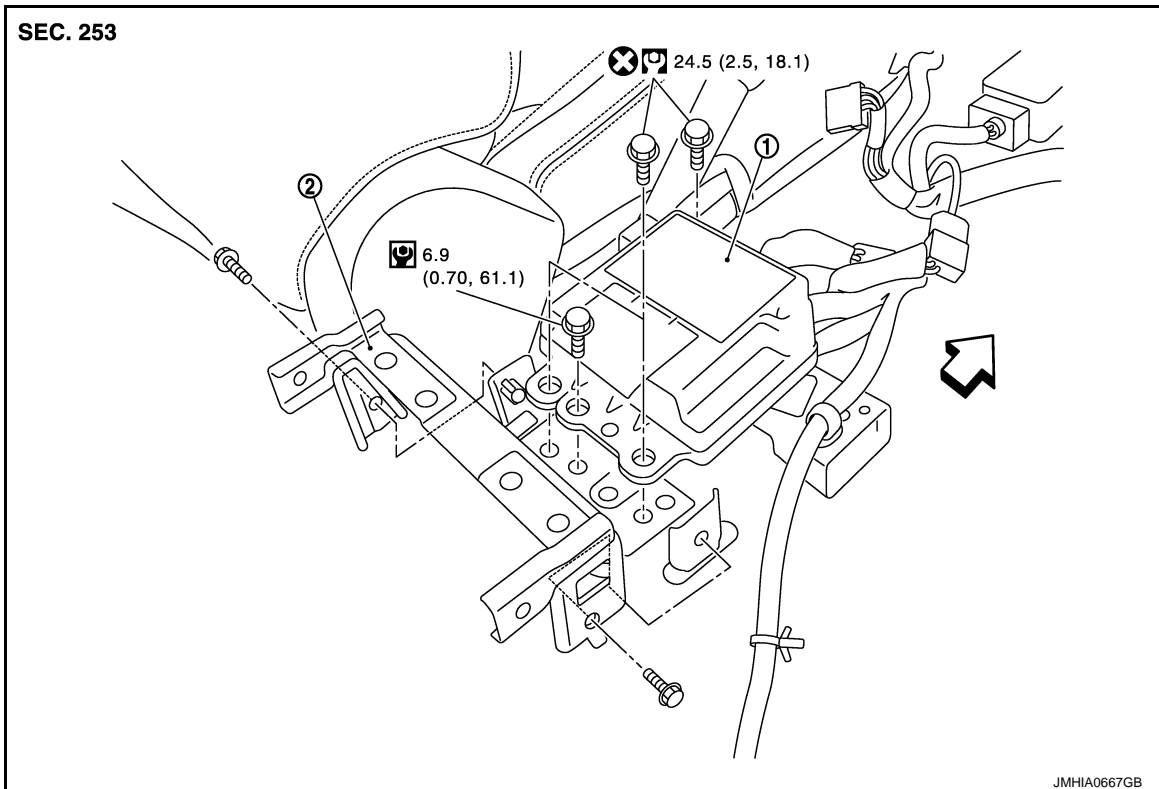

1. Diagnosis sensor unit                      2. Console bracket

↔ : Vehicle front

⊗ : Always replace after every disassembly.

⊕ : N·m (kg·m, ft·lb)

⊖ : N·m (kg·m, in·lb)

### Removal and Installation

INFOID:000000006562544

#### **WARNING:**

- Before servicing, turn ignition switch OFF, disconnect battery negative terminal and wait 3 minutes or more.
- Before disconnecting the air bag sensor unit harness connector, be sure to disconnect the each harness connector of the air bag module and the pre-tensioner seat belt to prevent air bag deployment by static electricity and the pre-tensioner seat belt operation.
- Never use the air tools or the electric tools for servicing.
- When replacing the air bag diagnosis sensor unit, always check with the parts department for the latest parts information. Installing an incorrect air bag diagnosis sensor unit may or may not cause the air bag warning lamp to illuminate and may cause incorrect deployment of the supplemental air bags and seat belt pre-tensioners in a collision resulting in serious personal injury or death.

#### REMOVAL

1. Always check the air bag diagnosis sensor unit ECU discriminated number (identification number) using CONSULT.
2. Disconnect each connector of all air bag modules and the pre-tensioner seat belts.
3. Remove the center console assembly. Refer to [IP-23. "Removal and Installation"](#).
4. Disconnect the diagnosis sensor unit harness connector.

## DIAGNOSIS SENSOR UNIT

### < REMOVAL AND INSTALLATION >

5. Remove the console bracket fixing bolts (A), and then remove the console bracket (1).
6. Remove the diagnosis sensor unit fixing bolts (B), and then remove the diagnosis sensor unit (2).

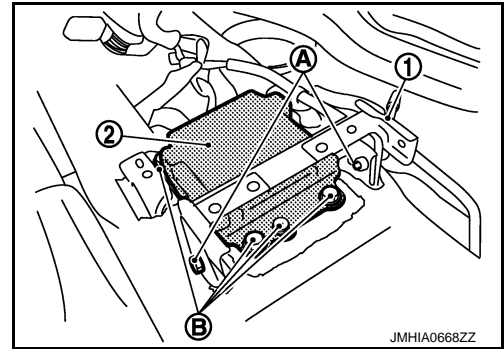

### CAUTION:

- Replace the diagnosis sensor unit of deployed driver air bag module, deployed passenger air bag module, deployed side air bag module, deployed curtain air bag module or deployed seat belt pretensioner.
- Never impact the diagnosis sensor unit.
- Replace the diagnosis sensor unit if it has been dropped or sustained an impact.



### INSTALLATION

Install air bag diagnosis sensor unit in the reverse order of removal.

### CAUTION:

- Never use the old bolts after removal, replace with the new bolts.
- Never damage the harness while installing.
- If malfunction is detected by the air bag warning lamp, after repair or replacement of the malfunctioning parts, reset the memory using self-diagnosis or CONSULT. Refer to [SRC-21, "CONSULT-III Function"](#).
- After the work is completed, check that no system malfunction is detected by air bag warning lamp.
- After replacing the air bag diagnosis sensor unit, confirm using CONSULT that the ECU discriminated number (identification number) of the new replacement air bag sensor unit matches the ECU discriminated number (identification number) of the replaced (old) air bag diagnosis sensor unit.

### NOTE:

If the ECU discriminated number of the new replacement air bag diagnosis sensor unit differs from the ECU discriminated number of the replaced air bag diagnosis sensor unit, reconfirm the parts information and verify that the correct air bag diagnosis sensor unit was installed.

# SEAT BELT PRE-TENSIONER

< REMOVAL AND INSTALLATION >

## SEAT BELT PRE-TENSIONER

### Removal and Installation

INFOID:000000006562545

For removal and installation procedures, refer to [SB-6. "SEAT BELT RETRACTOR : Removal and Installation"](#).

- A
- B
- C
- D
- E
- F
- G
- SR**
- I
- J
- K
- L
- M
- N
- O
- P

# OCCUPANT DETECTION SYSTEM CONTROL UNIT

< REMOVAL AND INSTALLATION >

## OCCUPANT DETECTION SYSTEM CONTROL UNIT

### Exploded View

INFOID:000000006600465

Refer to [SE-113. "Exploded View"](#).

### Removal and Installation

INFOID:000000006600466

#### REMOVAL

1. Remove passenger seat assembly. Refer to [SE-116. "Removal and Installation"](#).
2. Remove occupant detection system control unit (1) fixing screws (A).
3. Disconnect occupant detection system control unit harness connector.
4. Remove occupant detection system control unit from seat cushion frame (2).

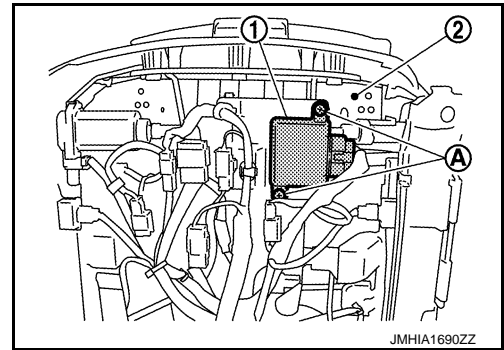

#### INSTALLATION

Install in the reverse order of removal.