

# SECTION **BCS**

## BODY CONTROL SYSTEM

A  
B  
C

### CONTENTS

<b>BASIC INSPECTION</b> .....	<b>COMMON ITEM</b> .....	F
<b>INSPECTION AND ADJUSTMENT</b> .....	COMMON ITEM : CONSULT Function (BCM - COMMON ITEM) .....	
<b>ADDITIONAL SERVICE WHEN REPLACING CONTROL UNIT (BCM)</b> .....	<b>DOOR LOCK</b> .....	G
ADDITIONAL SERVICE WHEN REPLACING CONTROL UNIT (BCM) : Description .....	DOOR LOCK : CONSULT Function (BCM - DOOR LOCK) .....	
ADDITIONAL SERVICE WHEN REPLACING CONTROL UNIT (BCM) : Work Procedure .....	<b>REAR WINDOW DEFOGGER</b> .....	H
<b>CONFIGURATION (BCM)</b> .....	REAR WINDOW DEFOGGER : CONSULT Function (BCM - REAR DEFOGGER) .....	
CONFIGURATION (BCM) : Description .....	<b>BUZZER</b> .....	I
CONFIGURATION (BCM) : Work Procedure .....	BUZZER : CONSULT Function (BCM - BUZZER)...	
CONFIGURATION (BCM) : Configuration list .....	<b>INT LAMP</b> .....	J
<b>TRANSIT MODE CANCEL OPERATION</b> .....	INT LAMP : CONSULT Function (BCM - INT LAMP) .....	
Description .....	<b>HEADLAMP</b> .....	K
Work Procedure .....	HEADLAMP : CONSULT Function (BCM - HEAD LAMP) .....	
<b>SYSTEM DESCRIPTION</b> .....	<b>WIPER</b> .....	L
<b>BODY CONTROL SYSTEM</b> .....	WIPER : CONSULT Function (BCM - WIPER) .....	
System Description .....	<b>FLASHER</b> .....	N
Component Parts Location .....	FLASHER : CONSULT Function (BCM - FLASHER) .....	
<b>COMBINATION SWITCH READING SYSTEM</b> .....	<b>INTELLIGENT KEY</b> .....	O
System Diagram .....	INTELLIGENT KEY : CONSULT Function (BCM - INTELLIGENT KEY) .....	
System Description .....	<b>COMB SW</b> .....	P
<b>SIGNAL BUFFER SYSTEM</b> .....	COMB SW : CONSULT Function (BCM - COMB SW) .....	
System Diagram .....	<b>BCM</b> .....	
System Description .....	BCM : CONSULT Function (BCM - BCM) .....	
<b>POWER CONSUMPTION CONTROL SYSTEM</b> .....	<b>IMMU</b> .....	
System Diagram .....	IMMU : CONSULT-III Function (BCM - IMMU) .....	
System Description .....		
Component Parts Location .....		
<b>DIAGNOSIS SYSTEM (BCM)</b> .....		

BCS

D  
E

F  
G

H  
I

J  
K

L  
M

N  
O

P  
Q

<b>BATTERY SAVER</b> .....	<b>32</b>	<b>POWER SUPPLY AND GROUND CIRCUIT</b> ....	<b>41</b>
BATTERY SAVER : CONSULT Function (BCM - BATTERY SAVER) .....	32	Diagnosis Procedure .....	41
<b>TRUNK</b> .....	<b>33</b>	<b>COMBINATION SWITCH INPUT CIRCUIT</b> .....	<b>42</b>
TRUNK : CONSULT Function (BCM - TRUNK) ....	33	Diagnosis Procedure .....	42
<b>THEFT ALM</b> .....	<b>34</b>	<b>COMBINATION SWITCH OUTPUT CIRCUIT</b> ...	<b>44</b>
THEFT ALM : CONSULT Function (BCM - THEFT ALM) .....	34	Diagnosis Procedure .....	44
<b>RETAINED PWR</b> .....	<b>35</b>	<b>ECU DIAGNOSIS INFORMATION</b> .....	<b>46</b>
RETAINED PWR : CONSULT Function (BCM - RE- TAINED PWR) .....	35	<b>BCM (BODY CONTROL MODULE)</b> .....	<b>46</b>
<b>SIGNAL BUFFER</b> .....	<b>35</b>	Reference Value .....	46
SIGNAL BUFFER : CONSULT Function (BCM - SIGNAL BUFFER) .....	35	Wiring Diagram - BCM - .....	68
<b>DTC/CIRCUIT DIAGNOSIS</b> .....	<b>36</b>	Fail-safe .....	72
<b>U1000 CAN COMM</b> .....	<b>36</b>	DTC Inspection Priority Chart .....	73
Description .....	36	DTC Index .....	74
DTC Logic .....	36	<b>SYMPTOM DIAGNOSIS</b> .....	<b>76</b>
Diagnosis Procedure .....	36	<b>COMBINATION SWITCH SYSTEM SYMP- TOMS</b> .....	<b>76</b>
<b>U1010 CONTROL UNIT (CAN)</b> .....	<b>37</b>	Symptom Table .....	76
DTC Logic .....	37	<b>NORMAL OPERATING CONDITION</b> .....	<b>77</b>
Diagnosis Procedure .....	37	Description .....	77
<b>U0415 VEHICLE SPEED SIG</b> .....	<b>38</b>	<b>PRECAUTION</b> .....	<b>78</b>
Description .....	38	<b>PRECAUTIONS</b> .....	<b>78</b>
DTC Logic .....	38	Precaution for Supplemental Restraint System (SRS) "AIR BAG" and "SEAT BELT PRE-TEN- SIONER" .....	78
Diagnosis Procedure .....	38	<b>REMOVAL AND INSTALLATION</b> .....	<b>79</b>
<b>B2562 LOW VOLTAGE</b> .....	<b>39</b>	<b>BCM (BODY CONTROL MODULE)</b> .....	<b>79</b>
DTC Logic .....	39	Exploded View .....	79
Diagnosis Procedure .....	39	Removal and Installation .....	79
<b>B26E7 TPMS CAN COMM</b> .....	<b>40</b>	<b>COMBINATION SWITCH</b> .....	<b>80</b>
DTC Logic .....	40	Exploded View .....	80
Diagnosis Procedure .....	40	Removal and Installation .....	80

# INSPECTION AND ADJUSTMENT

< BASIC INSPECTION >

## BASIC INSPECTION

### INSPECTION AND ADJUSTMENT

#### ADDITIONAL SERVICE WHEN REPLACING CONTROL UNIT (BCM)

#### ADDITIONAL SERVICE WHEN REPLACING CONTROL UNIT (BCM) : Description

INFOID:000000007805091

##### BEFORE REPLACEMENT

When replacing BCM, save or print current vehicle specification with CONSULT configuration before replacement.

##### NOTE:

If "READ CONFIGURATION" can not be used, use the "WRITE CONFIGURATION - Manual selection" after replacing BCM.

##### AFTER REPLACEMENT

##### CAUTION:

When replacing BCM, always perform "WRITE CONFIGURATION" with CONSULT. Or not doing so, BCM control function does not operate normally.

- Complete the procedure of "WRITE CONFIGURATION" in order.
- Configuration is different for each vehicle model. Confirm configuration of each vehicle model.
- If you set incorrect "WRITE CONFIGURATION", incidents might occur.

##### NOTE:

When replacing BCM, perform the system initialization (NATS) (if equipped).

#### ADDITIONAL SERVICE WHEN REPLACING CONTROL UNIT (BCM) : Work Procedure

INFOID:000000007805092

#### 1. SAVING VEHICLE SPECIFICATION

##### CONSULT Configuration

Perform "READ CONFIGURATION" to save or print current vehicle specification. Refer to [BCS-4, "CONFIGURATION \(BCM\) : Description"](#).

##### NOTE:

If "READ CONFIGURATION" can not be used, use the "WRITE CONFIGURATION - Manual selection" after replacing BCM.

>> GO TO 2.

#### 2. REPLACE BCM

Replace BCM. Refer to [BCS-79, "Removal and Installation"](#).

>> GO TO 3.

#### 3. WRITING VEHICLE SPECIFICATION

##### CONSULT Configuration

Perform "WRITE CONFIGURATION - Config file" or "WRITE CONFIGURATION - Manual selection" to write vehicle specification. Refer to [BCS-4, "CONFIGURATION \(BCM\) : Work Procedure"](#).

>> GO TO 4.

#### 4. INITIALIZE BCM (NATS) (IF EQUIPPED)

Perform BCM initialization. (NATS)

>> WORK END

#### CONFIGURATION (BCM)

A  
B  
C  
D  
E  
F  
G  
H  
I  
J  
K  
L

BCS

N  
O  
P

# INSPECTION AND ADJUSTMENT

< BASIC INSPECTION >

## CONFIGURATION (BCM) : Description

INFOID:000000007805093

Vehicle specification needs to be written with CONSULT because it is not written after replacing BCM. Configuration has three functions as follows.

Function	Description
READ CONFIGURATION	<ul style="list-style-type: none"><li>• Reads the vehicle configuration of current BCM.</li><li>• Saves the read vehicle configuration.</li></ul>
WRITE CONFIGURATION - Manual selection	Writes the vehicle configuration with manual selection.
WRITE CONFIGURATION - Config file	Writes the vehicle configuration with saved data.

### NOTE:

Manual setting item: Items which need selection by vehicle specifications

Automatic setting item: Items which are written in automatically (Setting can not be changed)

For some models and specifications, the automatic setting item may not be displayed.

### CAUTION:

**When replacing BCM, always perform "WRITE CONFIGURATION" with CONSULT. Or not doing so, BCM control function does not operate normally.**

- Complete the procedure of "WRITE CONFIGURATION" in order.
- Configuration is different for each vehicle model. Confirm configuration of each vehicle model.
- Never perform "WRITE CONFIGURATION" except for new BCM.
- If you set incorrect "WRITE CONFIGURATION", incidents might occur.

## CONFIGURATION (BCM) : Work Procedure

INFOID:000000007805094

### 1. WRITING MODE SELECTION

 CONSULT Configuration  
Select "CONFIGURATION" of BCM.

When writing saved data >> GO TO 2.  
When writing manually >> GO TO 3.

### 2. PERFORM "WRITE CONFIGURATION - CONFIG FILE"

 CONSULT Configuration  
Perform "WRITE CONFIGURATION - Config file".

>> WORK END

### 3. PERFORM "WRITE CONFIGURATION - MANUAL SELECTION"

-  CONSULT Configuration
1. Select "WRITE CONFIGURATION - Manual selection".
  2. Identify the correct model and configuration list. Refer to [BCS-5. "CONFIGURATION \(BCM\) : Configuration list"](#).
  3. Confirm and/or change setting value for each item.

#### CAUTION:

**Thoroughly read and understand the vehicle specification. ECU control may not operate normally if the setting is not correct.**

#### NOTE:

If items are not displayed, touch "SETTING". Refer to [BCS-5. "CONFIGURATION \(BCM\) : Configuration list"](#) for written items and setting value.

4. Select "SETTING".

#### CAUTION:

**Make sure to select "SETTING" even if the indicated configuration of brand new BCM is same as the desirable configuration. If not, configuration which is set automatically by selecting vehicle model can not be memorized.**

5. When "COMMAND FINISHED", select "END".

# INSPECTION AND ADJUSTMENT

< BASIC INSPECTION >

>> GO TO 4.

## 4. OPERATION CHECK

Confirm that each function controlled by BCM operates normally.

>> WORK END

## CONFIGURATION (BCM) : Configuration list

INFOID:000000007514191

### CAUTION:

Thoroughly read and understand the vehicle specification. ECU control may not operate normally if the setting is not correct.

MANUAL SETTING ITEM		NOTE
Items	Setting value	
BATTERY SAVER FUNCTION	MODE1	—
AUTO BACK DOOR	WITH	—
DTRL	WITH ⇔ WITHOUT	<ul style="list-style-type: none"> <li>• WITH: With daytime running light system</li> <li>• WITHOUT: Without daytime running light system</li> </ul>
RAIN SENSOR CONFIG	WITH ⇔ WITHOUT	—
Key Fob Type	MODE7	—

⇔: Items which confirm vehicle specifications

AUTO SETTING ITEM		NOTE
Items	Setting value	
UNLOCK WITH SHOCK	WITHOUT	—
AUTO DOOR LOCK SPEED	MODE2	—
P-POS WARN	MODE1	—
ROOF FUNCTION	W/O REQ SW	—
ROOM LAMP ON TIME	MODE5	—
ROOM LAMP OFF TIME	MODE5	—
AV C/U	WITH	—
Trunk/Glass Hatch select	Glass Hatch	Even on a vehicle without glass hatch. It displays "Glass Hatch".
TRANSIT MODE	WITH	—
TR OPEN SW (INT)	MODE1	—
DI LMP VARIAT	MODE2	—
LIGHT RECOG	MODE4	—
TRANSMISSION	AT with ABS	—
REAR WIPER	WITH	—
TR CANCEL SW	WITHOUT	—
BCM AC CONTROL	MODE1	—
WELCOME LIGHT TIMER2	MODE4	—
TPMS	TPMS SBF	—
RAIN SEN TYPE	MODE3	—
WELCOME LIGHT OP SET	WITH	—

# TRANSIT MODE CANCEL OPERATION

< BASIC INSPECTION >

---

## TRANSIT MODE CANCEL OPERATION

### Description

INFOID:000000007805095

- BCM is in transit mode if turn signal indicator on combination meter turns ON for 1 minute when ignition switch is turned from OFF to ON.
- In this case, cancel operation must be performed.

#### **NOTE:**

Do not cancel transit mode during storage of the vehicle. Always cancel transit mode before delivery of the vehicle to customer.

### Work Procedure

INFOID:000000007805096

#### 1. TRANSIT MODE CANCEL OPERATION

---

1. Turn ignition switch OFF.
2. Turn and hold front wiper switch to HI, and then operate turn signal switch to RH or LH.

>> GO TO 2.

#### 2. TRANSIT MODE CANCEL CHECK

---

1. Turn front wiper switch and turn signal switch OFF.
2. Turn ignition switch ON.
3. Check that turn signal indicator on combination meter does not turn ON.

>> WORK END

# BODY CONTROL SYSTEM

< SYSTEM DESCRIPTION >

## SYSTEM DESCRIPTION

### BODY CONTROL SYSTEM

#### System Description

INFOID:000000007514192

#### OUTLINE

- BCM (Body Control Module) controls the various electrical components. It inputs the information required to the control from CAN communication and the signal received from each switch and sensor.
- BCM has combination switch reading function for reading the operation status of combination switches (light, turn signal, wiper and washer) in addition to a function for controlling the operation of various electrical components. It also has the signal transmission function as the passed point of signal and the power saving control function that reduces the power consumption with the ignition switch OFF.
- BCM is equipped with the diagnosis function that performs the diagnosis with CONSULT and various settings.

#### BCM CONTROL FUNCTION LIST

System	Reference
Combination switch reading system	<a href="#">BCS-9, "System Diagram"</a>
Signal buffer system	<a href="#">BCS-13, "System Diagram"</a>
Power consumption control system	<a href="#">BCS-15, "System Diagram"</a>
Auto light system	<a href="#">EXL-13, "System Diagram"</a>
Turn signal and hazard warning lamp system	<a href="#">EXL-26, "System Diagram"</a>
Headlamp system	<a href="#">EXL-9, "System Diagram"</a>
Parking, license plate and tail lamps system	<a href="#">EXL-28, "System Diagram"</a>
Front fog lamp system	<a href="#">EXL-23, "System Diagram"</a>
Exterior lamp battery saver system	<a href="#">EXL-31, "System Diagram"</a>
Daytime running light system	<a href="#">EXL-16, "System Diagram"</a>
Interior room lamp control system	<a href="#">INL-7, "System Diagram"</a>
Step lamp system	
Interior room lamp battery saver system	<a href="#">INL-13, "System Diagram"</a>
Front wiper and washer system	<ul style="list-style-type: none"> <li>• <a href="#">WW-6, "WITH RAIN SENSOR : System Diagram"</a> (With rain sensor)</li> <li>• <a href="#">WW-10, "WITHOUT RAIN SENSOR : System Diagram"</a> (Without rain sensor)</li> </ul>
Rear wiper and washer system	<a href="#">WW-15, "System Diagram"</a>
Warning chime system	<a href="#">WCS-5, "WARNING CHIME SYSTEM : System Diagram"</a>
Door lock system	<a href="#">DLK-15, "System Diagram"</a>
Automatic back door system	<a href="#">DLK-49, "System Diagram"</a>
Infiniti Vehicle Immobilizer System (IVIS) - NATS	<a href="#">SEC-15, "System Diagram"</a>
Vehicle security system	<a href="#">SEC-19, "System Diagram"</a>
Panic alarm	
Automatic drive positioner system	<a href="#">ADP-13, "AUTOMATIC DRIVE POSITIONER SYSTEM : System Diagram"</a>
Rear window defogger system	<a href="#">DEF-4, "System Diagram"</a>

# BODY CONTROL SYSTEM

## < SYSTEM DESCRIPTION >

System	Reference
Intelligent Key system/engine start system	Door lock unlock function
	Remote keyless function
	Back door open function
	Warning function
	Key reminder function
	Engine start function
Power window system	<a href="#">PWC-7, "System Diagram"</a>
Retained accessory power (RAP) system	<a href="#">PWC-7, "System Description"</a>

## Component Parts Location

INFOID:000000007514193

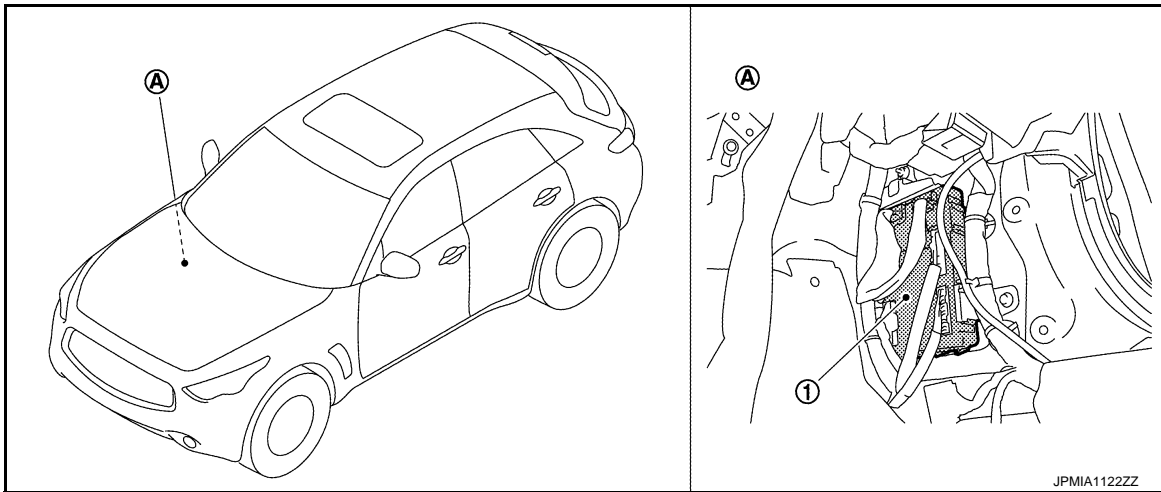

- 1. BCM
- A. Dash side lower (passenger side)



# COMBINATION SWITCH READING SYSTEM

< SYSTEM DESCRIPTION >

## COMBINATION SWITCH READING SYSTEM

### System Diagram

INFOID:000000007514194

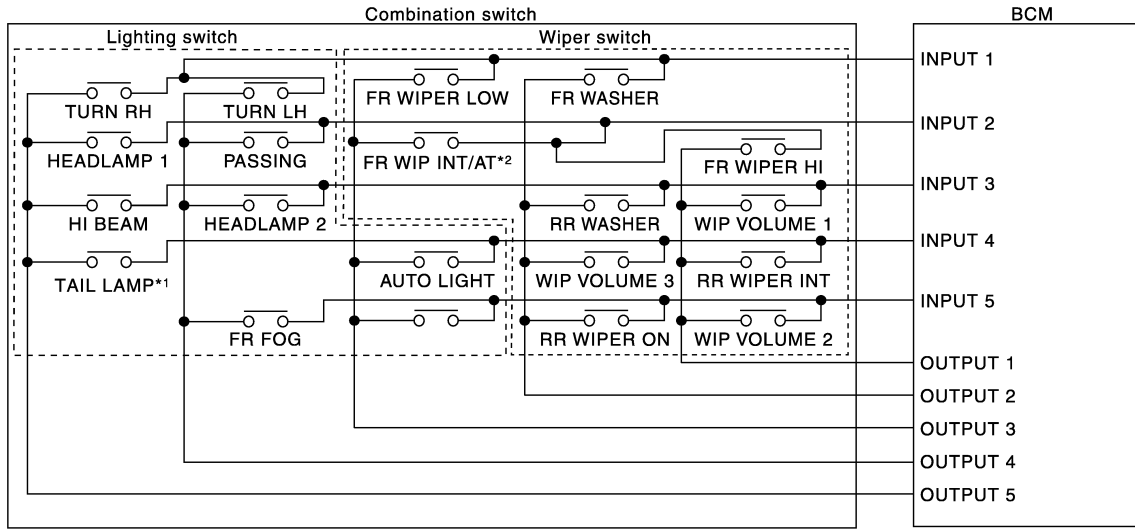

JMMIA0292GB

#### NOTE:

- \*1: TAIL LAMP switch links lighting switch 1ST position.
- \*2: "FR WIP INT/AT" is FR WIPER INT/AUTO.

### System Description

INFOID:000000007514195

#### OUTLINE

- BCM reads the status of the combination switch (light, turn signal, wiper and washer) and recognizes the status of each switch.
- BCM is a combination of 5 output terminals (OUTPUT 1 - 5) and 5 input terminals (INPUT 1 - 5). It reads a maximum of 20 switch status.

### COMBINATION SWITCH MATRIX

#### Combination switch circuit

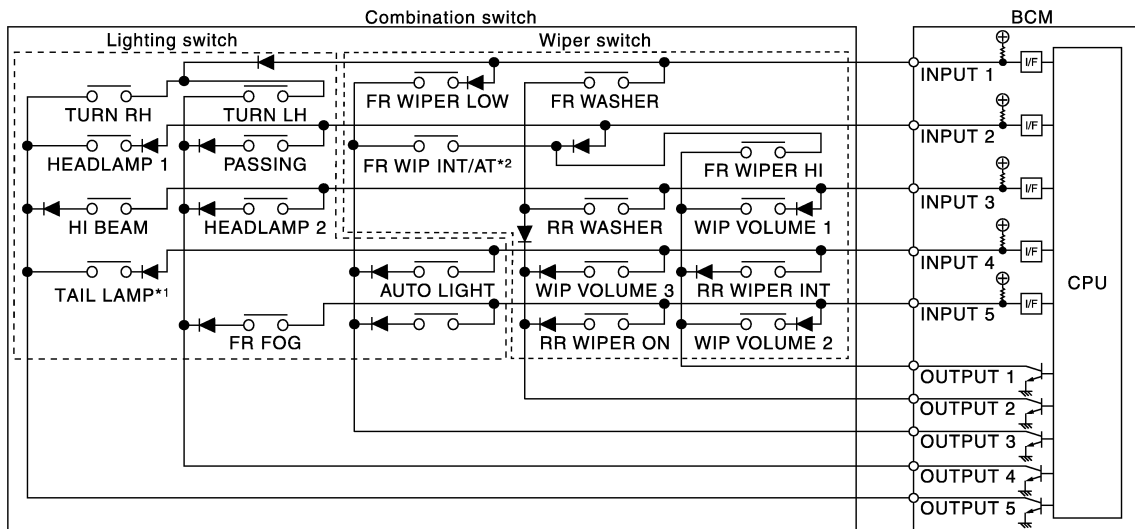

JMMIA0293GB

#### NOTE:

- \*1: TAIL LAMP switch links lighting switch 1ST position.
- \*2: "FR WIP INT/AT" is FR WIPER INT/AUTO.

A  
B  
C  
D  
E  
F  
G  
H  
I  
J  
K  
L  
N  
O  
P

BCS

# COMBINATION SWITCH READING SYSTEM

## < SYSTEM DESCRIPTION >

Combination switch INPUT-OUTPUT system list

System	OUTPUT 1	OUTPUT 2	OUTPUT 3	OUTPUT 4	OUTPUT 5
INPUT 1	—	FR WASHER	FR WIPER LOW	TURN LH	TURN RH
INPUT 2	FR WIPER HI	—	FR WIPER INT/ AUTO	PASSING	HEADLAMP 1
INPUT 3	WIP VOLUME 1	—	—	HEADLAMP 2	HI BEAM
INPUT 4	—	WIP VOLUME 3	AUTO LIGHT	—	TAIL LAMP
INPUT 5	WIP VOLUME 2	—	—	FR FOG	—

**NOTE:**

Headlamp has a dual system switch.

## COMBINATION SWITCH READING FUNCTION

Description

- BCM reads the status of the combination switch at 10 ms interval normally.

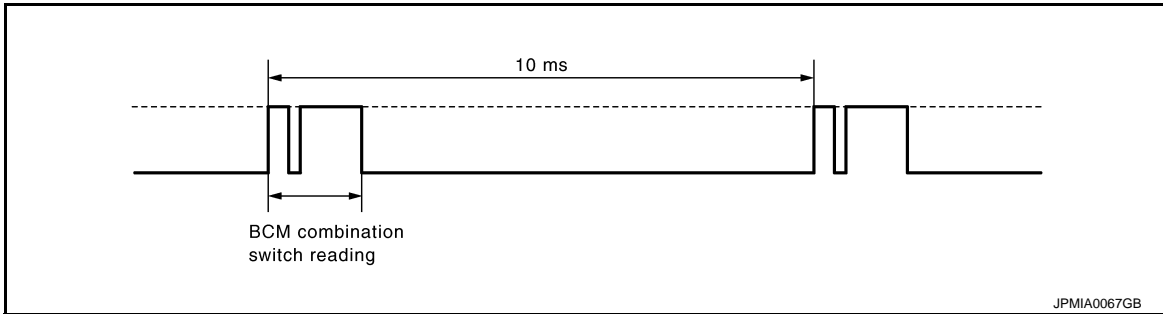

**NOTE:**

BCM reads the status of the combination switch at 60 ms interval when BCM is controlled at low power consumption mode.

- BCM operates as follows and judges the status of the combination switch.
  - INPUT 1 - 5 outputs the voltage waveforms of 5 systems simultaneously.
  - It operates the transistor on OUTPUT side in the following order: OUTPUT 5 → 4 → 3 → 2 → 1.
  - The voltage waveform of INPUT corresponding to the formed circuit changes according to the operation of the transistor on OUTPUT side if any (1 or more) switches are ON.
  - It reads this change of the voltage as the status signal of the combination switch.

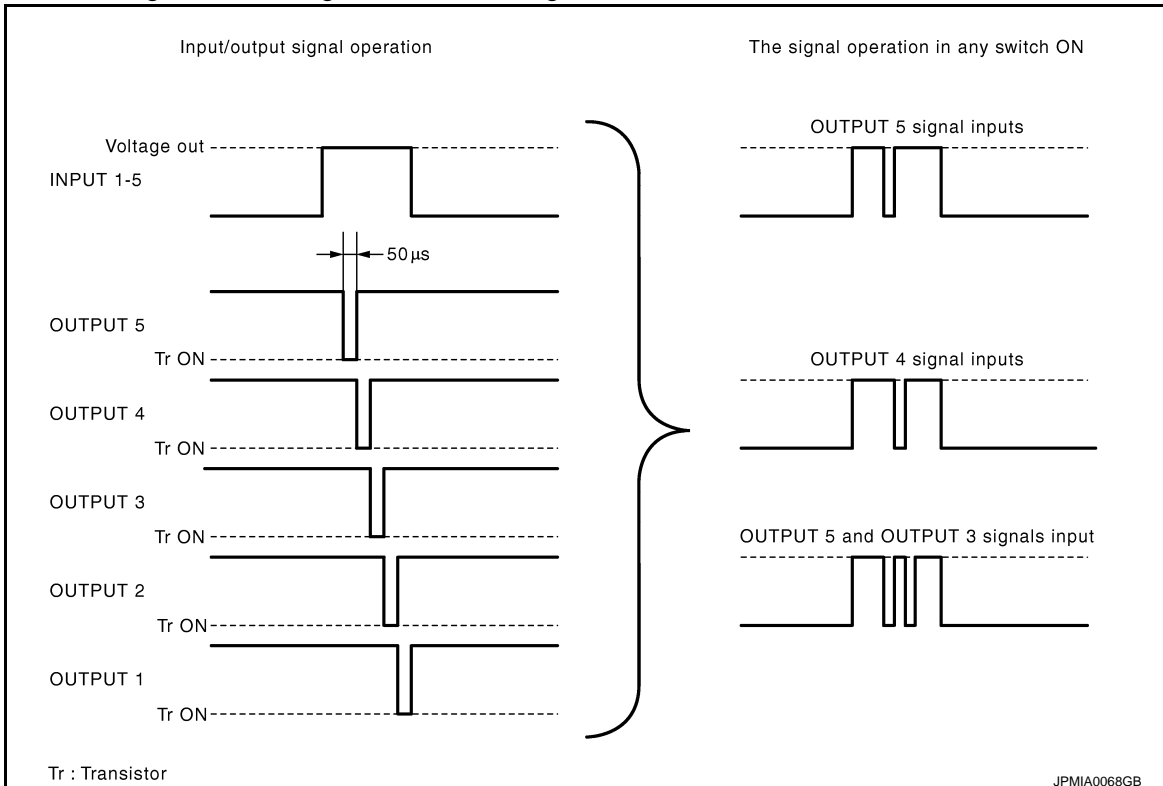

# COMBINATION SWITCH READING SYSTEM

## < SYSTEM DESCRIPTION >

### Operation Example

In the following operation example, the combination of the status signals of the combination switch is replaced as follows: INPUT 1 - 5 to "1 - 5" and OUTPUT 1 - 5 to "A - E".

Example 1: When a switch (TURN RH switch) is turned ON

- The circuit between INPUT 1 and OUTPUT 5 is formed when the TURN RH switch is turned ON.

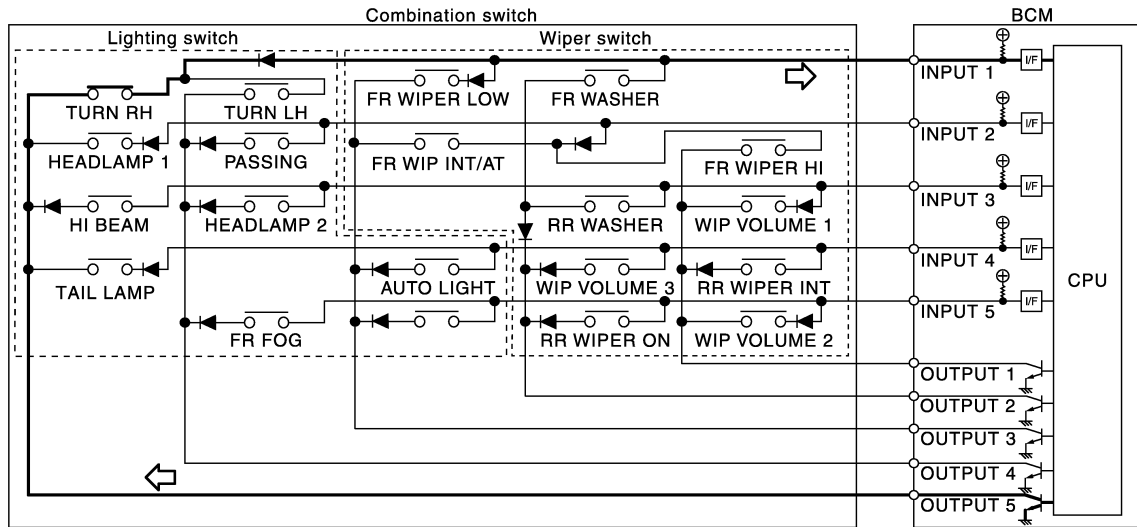

- BCM detects the combination switch status signal "1E" when the signal of OUTPUT 5 is input to INPUT 1.
- BCM judges that the TURN RH switch is ON when the signal "1E" is detected.

Example 2: When some switches (turn RH switch, front wiper LO switch) are turned ON

- The circuits between INPUT 1 and OUTPUT 5 and between INPUT 1 and OUTPUT 3 are formed when the TURN RH switch and FR WIPER LOW switch are turned ON.

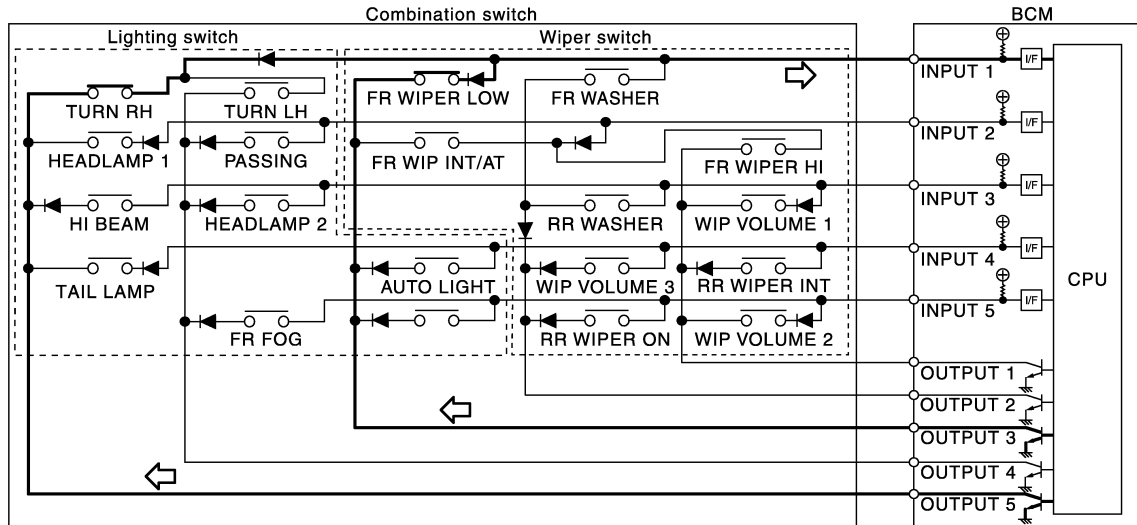

- BCM detects the combination switch status signal "1CE" when the signals of OUTPUT 3 and OUTPUT 5 are input to INPUT 1.
- BCM judges that the TURN RH switch and FR WIPER LOW switch are ON when the signal "1CE" is detected.

### WIPER VOLUME DIAL POSITION

BCM judges the wiper volume dial 1 - 7 by the status of WIP VOLUME 1, 2 and 3 switches.

Wiper volume dial position	Switch status		
	WIP VOLUME 1	WIP VOLUME 2	WIP VOLUME 3
1	ON	ON	ON
2	ON	ON	OFF

# COMBINATION SWITCH READING SYSTEM

## < SYSTEM DESCRIPTION >

Wiper volume dial position	Switch status		
	WIP VOLUME 1	WIP VOLUME 2	WIP VOLUME 3
3	ON	OFF	OFF
4	OFF	OFF	OFF
5	OFF	OFF	ON
6	OFF	ON	ON
7	OFF	ON	OFF

**NOTE:**

For details of wiper volume dial position, refer to [WW-6. "WITH RAIN SENSOR : System Description"](#) (with rain sensor), [WW-10. "WITH-OUT RAIN SENSOR : System Description"](#) (without rain sensor).

# SIGNAL BUFFER SYSTEM

< SYSTEM DESCRIPTION >

## SIGNAL BUFFER SYSTEM

### System Diagram

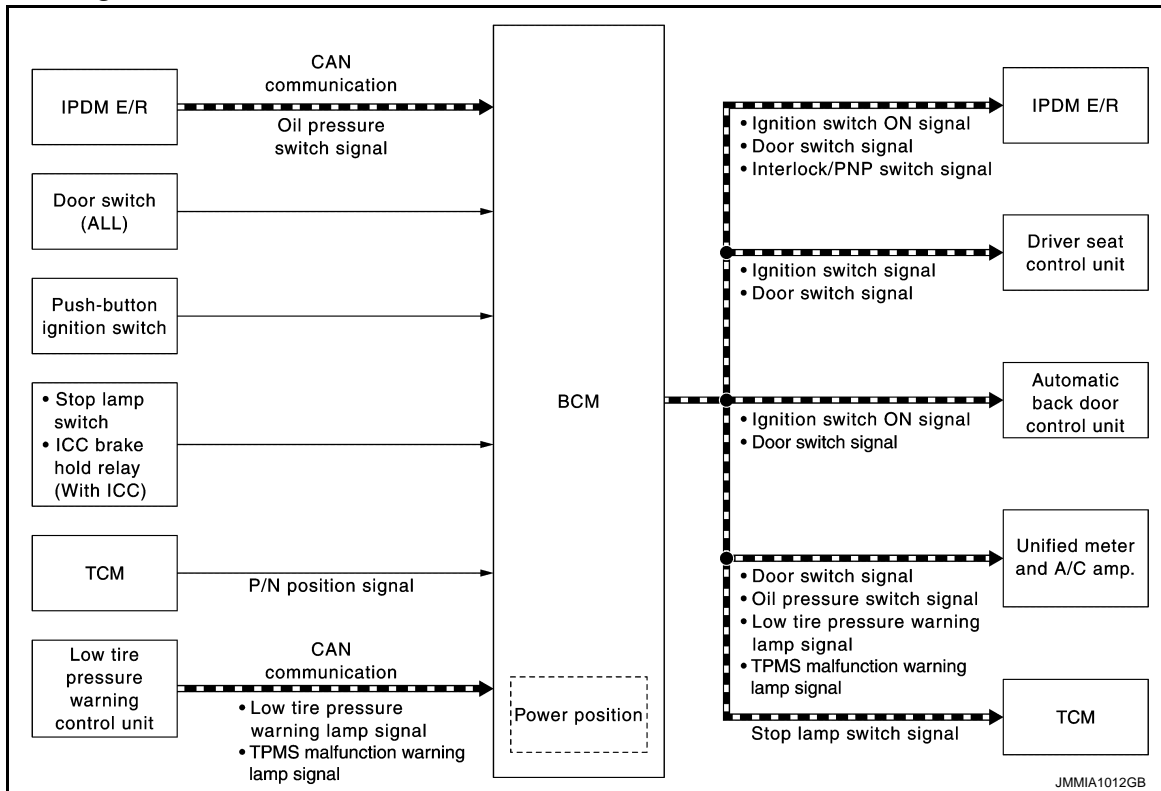

### System Description

INFOID:000000007514197

#### OUTLINE

BCM has the signal transmission function that outputs/transmits each input/received signal to each unit.

#### Signal transmission function list

Signal name	Input	Output	Description
<ul style="list-style-type: none"> <li>Ignition switch ON signal</li> <li>Ignition switch signal</li> </ul>	Push-button ignition switch (Push switch)	<ul style="list-style-type: none"> <li>IPDM E/R (CAN)</li> <li>Driver seat control unit (CAN)</li> <li>Automatic back door control unit (CAN)</li> </ul>	Inputs the push-button ignition switch (push switch) signal and transmits the ignition switch status judged with BCM via CAN communication.
Door switch signal	Any door switch	<ul style="list-style-type: none"> <li>Unified meter and A/C amp. (CAN)</li> <li>IPDM E/R (CAN)</li> <li>Driver seat control unit (CAN)</li> </ul>	Inputs the door switch signal and transmits it via CAN communication.
Oil pressure switch signal	IPDM E/R (CAN)	Unified meter and A/C amp. (CAN)	Transmits the received oil pressure switch signal via CAN communication.
Stop lamp switch signal	<ul style="list-style-type: none"> <li>Stop lamp switch</li> <li>ICC brake hold relay (With ICC)</li> </ul>	TCM (CAN)	Inputs the stop lamp switch 1 signal and stop lamp switch 2 signal, and transmits it via CAN communication.
Interlock/PNP switch signal	TCM	IPDM E/R	Inputs the selector lever P/N position signal, and transmits the interlock/PNP switch signal via CAN communication.

A  
B  
C  
D  
E  
F  
G  
H  
I  
J  
K  
L

BCS

N  
O  
P

## SIGNAL BUFFER SYSTEM

### < SYSTEM DESCRIPTION >

Signal name	Input	Output	Description
Low tire pressure warning lamp signal	Low tire pressure warning control unit	Unified meter and A/C amp. (CAN)	Transmits the received low tire pressure warning lamp signal via CAN communication.
TPMS malfunction warning lamp signal	Low tire pressure warning control unit	Unified meter and A/C amp. (CAN)	Transmits the received TPMS malfunction warning lamp signal via CAN communication.

# POWER CONSUMPTION CONTROL SYSTEM

< SYSTEM DESCRIPTION >

## POWER CONSUMPTION CONTROL SYSTEM

### System Diagram

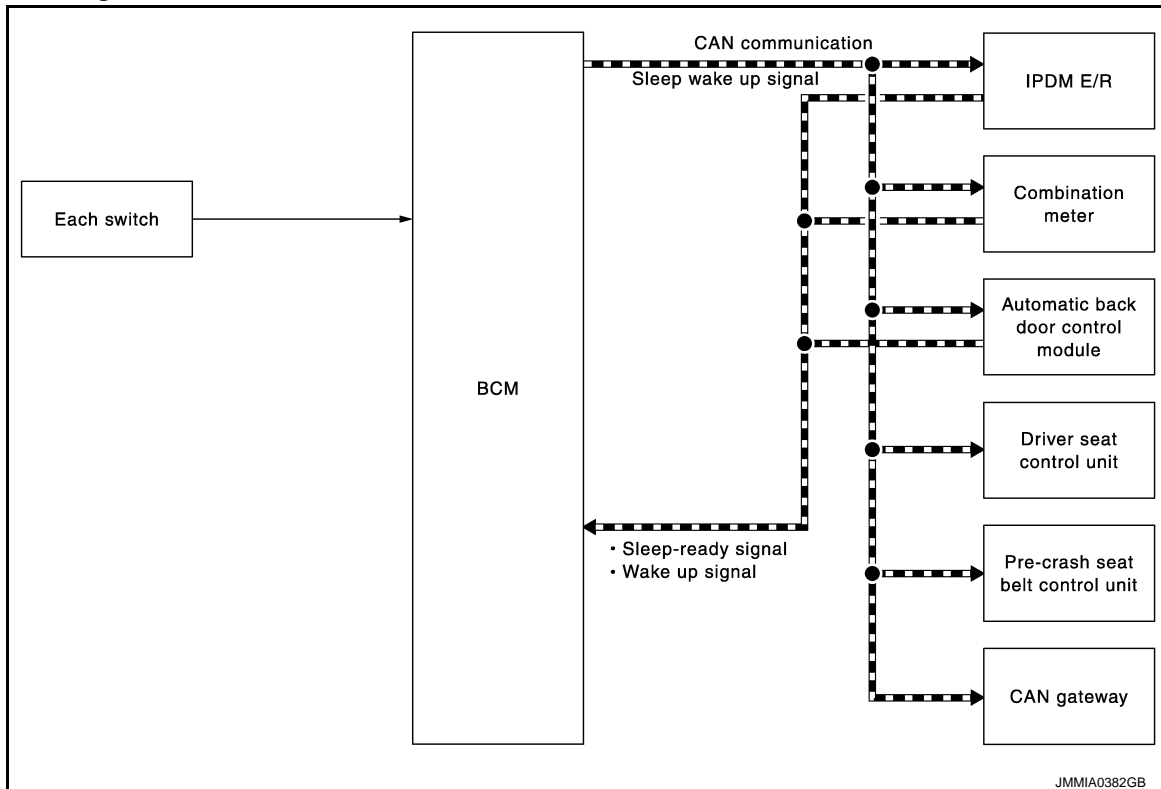

#### NOTE:

Combination meter is received via unified meter and A/C amp.

### System Description

INFOID:000000007514199

#### OUTLINE

- BCM incorporates a power saving control function that reduces the power consumption according to the vehicle status.
- BCM switches the status (control mode) by itself with the power saving control function. It performs the sleep request to each unit [IPDM E/R, combination meter (unified meter and A/C amp.), driver seat control unit, pre-crash seat belt control unit, automatic back door control unit and CAN gateway] that operates with the ignition switch OFF.

#### Normal mode (wake-up)

- CAN communication is normally performed with other units
- Each control with BCM is operating properly

#### CAN communication sleep mode (CAN sleep)

- CAN transmission is stopped
- Control with BCM only is operating

#### Low power consumption mode (BCM sleep)

- Low power consumption control is active
- CAN transmission is stopped

#### LOW POWER CONSUMPTION CONTROL WITH BCM

BCM reduces the power consumption with the following operation in the low power consumption mode.

- The reading interval of the each switches changes from 10 ms interval to 60 ms interval.

#### Sleep mode activation

- BCM receives the sleep-ready signal (ready) from IPDM E/R, unified meter and A/C amp. and automatic back door control unit via CAN communication.
- BCM transmits the sleep wake up signal (sleep) to each unit when all of the CAN sleep conditions are fulfilled.

A  
B  
C  
D  
E  
F  
G  
H  
I  
J  
K  
L

BCS

N  
O  
P

# POWER CONSUMPTION CONTROL SYSTEM

## < SYSTEM DESCRIPTION >

- Each unit stops the transmission of CAN communication with the sleep wake up signal. BCM is in CAN communication sleep mode.
- BCM is in the low power consumption mode and perform the low power consumption control when all of the BCM sleep conditions are fulfilled with CAN sleep condition.

### Sleep condition

CAN sleep condition	BCM sleep condition
<ul style="list-style-type: none"> <li>• Receiving the sleep-ready signal (ready) from all units</li> <li>• Ignition switch: OFF</li> <li>• Vehicle security system and panic alarm: Not operation</li> <li>• Warning chime: Not operation</li> <li>• Intelligent Key system buzzer: Not operation</li> <li>• Stop lamp switch: OFF</li> <li>• ICC brake hold relay (with ICC): OFF</li> <li>• Key slot (card switch) status: No change</li> <li>• Turn signal indicator lamp: Not operation</li> <li>• Exterior lamp: OFF</li> <li>• Door lock status: No change</li> <li>• CONSULT communication status: Not communication</li> <li>• Meter display signal: Non-transmission</li> <li>• Door switch status: No change</li> <li>• Rear window defogger: OFF</li> </ul>	<ul style="list-style-type: none"> <li>• Interior room lamp battery saver: Time out</li> <li>• RAP system: OFF</li> <li>• Power window switch communication: No transmission</li> <li>• Push-button ignition switch illumination: OFF</li> <li>• Infiniti Vehicle Immobilizer System (IVIS) - NATS: Not operation</li> <li>• Remote keyless entry receiver communication status: No communication</li> <li>• LOCK indicator lamp: OFF</li> <li>• ACC indicator lamp: OFF</li> <li>• ON indicator lamp: OFF</li> </ul>

### Wake-up operation

- BCM changes from the low power consumption mode to the CAN communication sleep mode when the any of the BCM wake-up conditions is fulfilled. Only the control with BCM is activated.
- BCM transmits the sleep wake up signal (wake up) to each unit when any of the CAN wake-up conditions is fulfilled. It changes from the low power consumption mode or the CAN communication sleep mode to the normal mode.
- Each unit starts the transmission of CAN communication with the sleep wake up signal. In addition, the unified meter and A/C amp. transmits the wake up signal to BCM via CAN communication to report the CAN communication start.

### Wake-up condition

BCM wake-up condition	CAN wake-up condition
<ul style="list-style-type: none"> <li>• Power window switch communication: Receiving</li> <li>• Remote keyless entry receiver: Receiving</li> </ul>	<ul style="list-style-type: none"> <li>• Receiving the sleep-ready signal (Not-ready) from any units</li> <li>• Key slot (key switch): OFF → ON, ON → OFF</li> <li>• Push-button ignition switch (push switch): OFF → ON</li> <li>• Hazard switch: OFF → ON</li> <li>• PASSING switch: OFF → ON, ON → OFF</li> <li>• TAIL LAMP switch: OFF → ON</li> <li>• Driver door switch: OFF → ON, ON → OFF</li> <li>• Passenger door switch: OFF → ON, ON → OFF</li> <li>• Rear RH door switch: OFF → ON, ON → OFF</li> <li>• Rear LH door switch: OFF → ON, ON → OFF</li> <li>• Back door switch: OFF → ON, ON → OFF</li> <li>• Driver door request switch: OFF → ON</li> <li>• Passenger door request switch: OFF → ON</li> <li>• Back door opener request switch: OFF → ON</li> <li>• Stop lamp switch: ON</li> <li>• ICC brake hold relay (with ICC): ON</li> </ul>



# POWER CONSUMPTION CONTROL SYSTEM

< SYSTEM DESCRIPTION >

## Component Parts Location

INFOID:000000007514200

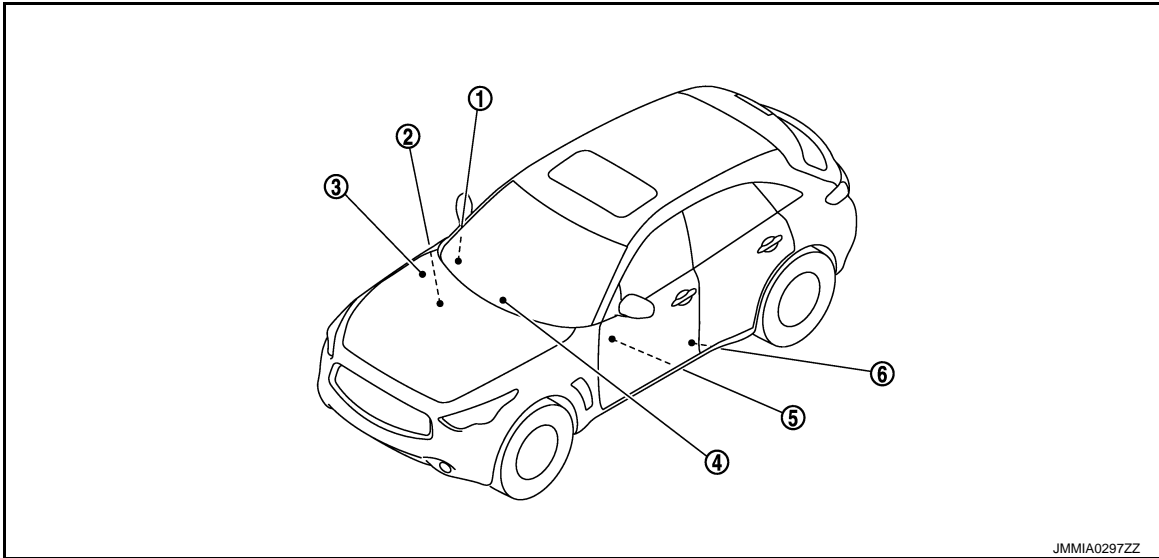

- |   |  |   |
|---|--|---|
| 1. CAN gateway<br>Refer to <a href="#">LAN-93, "Component Parts Location"</a> .                               | 2. BCM<br>Refer to <a href="#">BCS-8, "Component Parts Location"</a> .   | 3. IPDM E/R<br>Refer to <a href="#">PCS-5, "Component Parts Location"</a> .                         |
| 4. Unified meter and A/C amp.<br>Refer to <a href="#">MWI-10, "METER SYSTEM : Component Parts Location"</a> . | 5. Driver seat control unit<br>Refer to <a href="#">ADP-15, "AUTOMATIC DRIVE POSITIONER SYSTEM : Component Parts Location"</a> . | 6. Pre-crash seat belt control unit<br>Refer to <a href="#">SBC-9, "Component Parts Location"</a> . |

A  
B  
C  
D  
E  
F  
G  
H  
I  
J  
K  
L  
N  
O  
P

BCS

# DIAGNOSIS SYSTEM (BCM)

< SYSTEM DESCRIPTION >

## DIAGNOSIS SYSTEM (BCM)

### COMMON ITEM

#### COMMON ITEM : CONSULT Function (BCM - COMMON ITEM)

INFOID:000000007514201

#### APPLICATION ITEM

CONSULT performs the following functions via CAN communication with BCM.

Diagnosis mode	Function Description
Work Support	Changes the setting for each system function.
Self Diagnostic Result	Displays the diagnosis results judged by BCM.
CAN Diag Support Monitor	Monitors the reception status of CAN communication viewed from BCM.
Data Monitor	The BCM input/output signals are displayed.
Active Test	The signals used to activate each device are forcibly supplied from BCM.
Ecu Identification	The BCM part number is displayed.
Configuration	<ul style="list-style-type: none"> <li>Read and save the vehicle specification.</li> <li>Write the vehicle specification when replacing BCM.</li> </ul>

#### SYSTEM APPLICATION

BCM can perform the following functions for each system.

#### NOTE:

It can perform the diagnosis modes except the following for all sub system selection items.

×: Applicable item

System	Sub system selection item	Diagnosis mode		
		Work Support	Data Monitor	Active Test
Door lock	DOOR LOCK	×	×	×
Rear window defogger	REAR DEFOGGER		×	×
Warning chime	BUZZER		×	×
Interior room lamp timer	INT LAMP	×	×	×
Exterior lamp	HEAD LAMP	×	×	×
Wiper and washer	WIPER	×	×	×
Turn signal and hazard warning lamps	FLASHER	×	×	×
—	AIR CONDITONER*			
<ul style="list-style-type: none"> <li>Intelligent Key system</li> <li>Engine start system</li> </ul>	INTELLIGENT KEY	×	×	×
Combination switch	COMB SW		×	
Body control system	BCM	×		
IVIS - NATS	IMMU		×	×
Interior room lamp battery saver	BATTERY SAVER	×	×	×
Back door open	TRUNK		×	×
Vehicle security system	THEFT ALM	×	×	×
RAP system	RETAINED PWR		×	
Signal buffer system	SIGNAL BUFFER		×	×

#### NOTE:

\*: This item is displayed, but is not used.

#### FREEZE FRAME DATA (FFD)

The BCM records the following vehicle condition at the time a particular DTC is detected, and displays on CONSULT.

# DIAGNOSIS SYSTEM (BCM)

## < SYSTEM DESCRIPTION >

CONSULT screen item	Indication/Unit	Description		
Vehicle Speed	km/h	Vehicle speed of the moment a particular DTC is detected		A
Odo/Trip Meter	km	Total mileage (Odometer value) of the moment a particular DTC is detected		
Vehicle Condition	SLEEP>LOCK	Power position status of the moment a particular DTC is detected*	While turning BCM status from low power consumption mode to normal mode (Power supply position is "LOCK"*)	B
	SLEEP>OFF		While turning BCM status from low power consumption mode to normal mode (Power supply position is "OFF".)	C
	LOCK>ACC		While turning power supply position from "LOCK" to "ACC"	
	ACC>ON		While turning power supply position from "ACC" to "IGN"	D
	RUN>ACC		While turning power supply position from "RUN" to "ACC" (Vehicle is stopping and selector lever is except P position.)	
	CRANK>RUN		While turning power supply position from "CRANKING" to "RUN" (From cranking up the engine to run it)	E
	RUN>URGENT		While turning power supply position from "RUN" to "ACC" (Emergency stop operation)	F
	ACC>OFF		While turning power supply position from "ACC" to "OFF"	
	OFF>LOCK		While turning power supply position from "OFF" to "LOCK"*	G
	OFF>ACC		While turning power supply position from "OFF" to "ACC"	
	ON>CRANK		While turning power supply position from "IGN" to "CRANKING"	
	OFF>SLEEP		While turning BCM status from normal mode (Power supply position is "OFF".) to low power consumption mode	H
	LOCK>SLEEP		While turning BCM status from normal mode (Power supply position is "LOCK".) to low power consumption mode	I
	LOCK		Power supply position is "LOCK"*	
	OFF		Power supply position is "OFF" (Ignition switch OFF)	J
	ACC		Power supply position is "ACC" (Ignition switch ACC)	
	ON		Power supply position is "IGN" (Ignition switch ON with engine stopped)	K
	ENGINE RUN		Power supply position is "RUN" (Ignition switch ON with engine running)	
CRANKING	Power supply position is "CRANKING" (At engine cranking)	L		
IGN Counter	0 - 39	The number of times that ignition switch is turned ON after DTC is detected <ul style="list-style-type: none"> <li>• The number is 0 when a malfunction is detected now.</li> <li>• The number increases like 1 → 2 → 3...38 → 39 after returning to the normal condition whenever ignition switch OFF → ON.</li> <li>• The number is fixed to 39 until the self-diagnosis results are erased if it is over 39.</li> </ul>		BCS

### NOTE:

\*: Power supply position shifts to "LOCK" from "OFF", when ignition switch is in the OFF position, selector lever is in the P position, and any of the following conditions are met.

- Closing door
- Opening door
- Door is locked using door request switch
- Door is locked using Intelligent Key

The power supply position shifts to "ACC" when the push-button ignition switch (push switch) is pushed at "LOCK".

## DOOR LOCK

### DOOR LOCK : CONSULT Function (BCM - DOOR LOCK)

INFOID:000000007806409

### BCM CONSULT FUNCTION

CONSULT performs the following functions via CAN communication with BCM.

# DIAGNOSIS SYSTEM (BCM)

## < SYSTEM DESCRIPTION >

Diagnosis mode	Function Description
WORK SUPPORT	Changes the setting for each system function.
DATA MONITOR	The BCM input/output signals are displayed.
ACTIVE TEST	The signals used to activate each device are forcibly supplied from BCM.

## WORK SUPPORT

Monitor item	Description
DOOR LOCK-UNLOCK SET	Selective unlock function mode can be changed to operate (WITH) or not operate (WITHOUT) with this mode.
AUTOMATIC DOOR LOCK SELECT	Automatic door lock function mode can be selected from the following in this mode. <ul style="list-style-type: none"> <li>VH SPD: All doors are locked when vehicle speed more than 24km/h (15MPH)</li> <li>P RANGE: All doors are locked when shifting the selector lever from P position to other than the P position</li> </ul>
AUTOMATIC DOOR UNLOCK SELECT	Automatic door unlock function mode can be selected from the following in the mode. <ul style="list-style-type: none"> <li>MODE 1: All doors are unlocked when the power supply position is changed from ON to OFF</li> <li>MODE 2: All doors are unlocked when shifting the selector lever from any position other than the P to P position</li> <li>MODE 3: Driver side door is unlocked when the power supply position is changed from ON to OFF</li> <li>MODE 4: Driver side door is unlocked when shifting the selector lever from any position other than the P to P position</li> </ul>
AUTOMATIC LOCK/UNLOCK SET	Automatic door lock/unlock function mode can be selected from the following in this mode. <ul style="list-style-type: none"> <li>Off: non-operational</li> <li>Unlock Only: door unlock operation only</li> <li>Lock Only: door lock operation only</li> <li>Lock/Unlock: lock/unlock operation</li> </ul>

## DATA MONITOR

Monitor Item	Contents
REQ SW-DR	Indicated [ON/OFF] condition of door request switch (driver side).
REQ SW-AS	Indicated [ON/OFF] condition of door request switch (passenger side).
REQ SW-BD/TR	Indicated [ON/OFF] condition of back door request switch.
DOOR SW-DR	Indicated [ON/OFF] condition of front door switch (driver side).
DOOR SW-AS	Indicated [ON/OFF] condition of front door switch (passenger side).
DOOR SW-RR	Indicated [ON/OFF] condition of rear door switch RH.
DOOR SW-RL	Indicated [ON/OFF] condition of rear door switch LH.
DOOR SW-BK	Indicated [ON/OFF] condition of back door switch.
CDL LOCK SW	Indicated [ON/OFF] condition of lock signal from door lock unlock switch.
CDL UNLOCK SW	Indicated [ON/OFF] condition of unlock signal from door lock unlock switch.
KEY CYL LK-SW	Indicated [ON/OFF] condition of lock signal from door key cylinder.
KEY CYL UN-SW	Indicated [ON/OFF] condition of unlock signal from door key cylinder.

## ACTIVE TEST

# DIAGNOSIS SYSTEM (BCM)

## < SYSTEM DESCRIPTION >

Test item	Description
DOOR LOCK	<p>This test is able to check door lock/unlock operation.</p> <ul style="list-style-type: none"> <li>The all door lock actuators are locked when "ALL LCK" on CONSULT screen is touched.</li> <li>The all door lock actuators are unlocked when "ALL UNLK" on CONSULT screen is touched.</li> <li>The door lock actuator (driver side) is unlocked when "DR UNLK" on CONSULT screen is touched.</li> <li>The door lock actuator (passenger side) is unlocked when "AS UNLK" on CONSULT screen is touched.</li> <li>The door lock actuator (rear LH and RH) is unlocked when "OTR ULK" on CONSULT screen is touched.</li> </ul>

## REAR WINDOW DEFOGGER

### REAR WINDOW DEFOGGER : CONSULT Function (BCM - REAR DEFOGGER)

INFOID:000000007805098

#### Data monitor

Monitor Item	Description
REAR DEF SW	This is displayed even when it is not equipped.
PUSH SW	Indicates [ON/OFF] condition of push switch.

#### ACTIVE TEST

Test Item	Description
REAR DEFOGGER	Rear window defogger operates when "ON" on CONSULT screen is touched.

## BUZZER

### BUZZER : CONSULT Function (BCM - BUZZER)

INFOID:000000007805099

#### CONSULT APPLICATION ITEMS

Test item	Diagnosis mode	Description
BUZZER	Data Monitor	Displays BCM input data in real time.
	Active Test	Operation of electrical loads can be checked by sending driving signal to them.

#### DATA MONITOR

Display item [Unit]	Description
PUSH SW [On/Off]	Status of push button ignition switch judged by BCM.
UNLK SEN-DR [On/Off]	Status of unlock sensor judged by BCM.
VEH SPEED 1 [Km/h or mph]	Value of vehicle speed signal received from ABS actuator and electric unit (control unit) with CAN communication line.
KEY SW-SLOT [On/Off]	Status of key slot judged by BCM.
TAIL LAMP SW [On/Off]	Status of each switch judged by BCM using the combination switch readout function.
FR FOG SW [On/Off]	Status of front fog lamp switch judged by BCM.
DOOR SW-DR [On/Off]	Status of driver side door switch judged by BCM.

#### ACTIVE TEST

A  
B  
C  
D  
E  
F  
G  
H  
I  
J  
K  
L

BCS

N  
O  
P

# DIAGNOSIS SYSTEM (BCM)

## < SYSTEM DESCRIPTION >

Display item [Unit]	Description
IGN KEY WARN ALM	The key warning chime operation can be checked by operating the relevant function (On/Off).
SEAT BELT WARN TEST	The seat belt warning chime operation can be checked by operating the relevant function (On/Off).
LIGHT WARN ALM	The light warning chime operation can be checked by operating the relevant function (On/Off).

## INT LAMP

### INT LAMP : CONSULT Function (BCM - INT LAMP)

INFOID:000000007806357

## WORK SUPPORT

Service item	Setting item	Setting
SET I/L D-UNLCK INTCON	On*	Interior room lamps link with door unlock. (Interior room lamp timer function)
	Off	Interior room lamps do not link with door unlock.
ROOM LAMP TIMER SET	MODE 2	7.5 sec.
	MODE 3*	15 sec.
	MODE 4	30 sec.
ROOM LAMP ON TIME SET	MODE 1	<b>NOTE:</b> The item is indicated, but not used.
	MODE 2	
	MODE 3	
	MODE 4	
	MODE 5*	
ROOM LAMP OFF TIME SET	MODE 1	<b>NOTE:</b> The item is indicated, but not used.
	MODE 2	
	MODE 3	
	MODE 4	
	MODE 5*	
R LAMP TIMER LOGIC SET	MODE 1*	Interior room lamp timer activates by synchronizing all doors.
	MODE 2	Interior room lamp timer activates by synchronizing the driver door only.

\*: Factory setting

## DATA MONITOR

Monitor item [Unit]	Description
REQ SW-DR [On/Off]	The switch status input from request switch (driver side)
REQ SW-AS [On/Off]	The switch status input from request switch (passenger side)
REQ SW-RR [On/Off]	<b>NOTE:</b> The item is indicated, but not monitored.
REQ SW-RL [On/Off]	
PUSH SW [On/Off]	The switch status input from push-button ignition switch
UNLK SEN-DR [On/Off]	Driver door unlock status input from unlock sensor

# DIAGNOSIS SYSTEM (BCM)

## < SYSTEM DESCRIPTION >

Monitor item [Unit]	Description
KEY SW-SLOT [On/Off]	Key switch status input from key slot
DOOR SW-DR [On/Off]	The switch status input from front door switch (driver side)
DOOR SW-AS [On/Off]	The switch status input from front door switch (passenger side)
DOOR SW-RR [On/Off]	The switch status input from rear door switch (RH)
DOOR SW- RL [On/Off]	The switch status input from rear door switch (LH)
DOOR SW-BK [On/Off]	The switch status input from back door switch
CDL LOCK SW [On/Off]	Lock switch status received from central door lock/unlock switch by power window switch serial link
CDL UNLOCK SW [On/Off]	Unlock switch status received from central door lock/unlock switch by power window switch serial link
KEY CYL LK-SW [On/Off]	Lock switch status received from key cylinder lock/unlock switch by power window switch serial link
KEY CYL UN-SW [On/Off]	Unlock switch status received from key cylinder lock/unlock switch by power window switch serial link
TRNK/HAT MNTR [On/Off]	The switch status input from trunk room lamp switch
RKE-LOCK [On/Off]	Lock signal status received from remote keyless entry receiver
RKE-UNLOCK [On/Off]	Unlock signal status received from remote keyless entry receiver

## ACTIVE TEST

Test item	Operation	Description
INT LAMP	On	Outputs the room lamp timer signal to the total illumination control unit to activate interior room lamps. (Hospitality lighting functioning table "Scene 1")
	Off	Stops the room lamp timer signal.
STEP LAMP TEST	On	Outputs the step lamp control signal to turn step lamp ON.
	Off	Stops the step lamp control signal to turn step lamp OFF.
LUGGAGE LAMP TEST	On	<b>NOTE:</b> The item is indicated, but not used.
	Off	

## HEADLAMP

### HEADLAMP : CONSULT Function (BCM - HEAD LAMP)

INFOID:000000007806351

## WORK SUPPORT

Service item	Setting item	Setting
CUSTOM A/LIGHT SETTING	MODE 1*	Normal
	MODE 2	More sensitive setting than normal setting (Turns ON earlier than normal operation.)
	MODE 3	More sensitive setting than MODE 2 (Turns ON earlier than MODE 2.)
	MODE 4	Less sensitive setting than normal setting (Turns ON later than normal operation.)
BATTERY SAVER SET	On*	With the exterior lamp battery saver function
	Off	Without the exterior lamp battery saver function

# DIAGNOSIS SYSTEM (BCM)

## < SYSTEM DESCRIPTION >

Service item	Setting item	Setting
ILL DELAY SET	MODE 1*	45 sec.
	MODE 2	Without the function
	MODE 3	30 sec.
	MODE 4	60 sec.
	MODE 5	90 sec.
	MODE 6	120 sec.
	MODE 7	150 sec.
	MODE 8	180 sec.

Sets delay timer function timer operation time.  
(All doors closed)

\*: Factory setting

## DATA MONITOR

Monitor item [Unit]	Description
PUSH SW [On/Off]	The switch status input from push-button ignition switch
ENGINE STATE [Stop/Stall/Crank/Run]	The engine status received from ECM with CAN communication
VEH SPEED 1 [km/h]	The value of the vehicle speed received from unified meter and A/C amp. with CAN communication
KEY SW-SLOT [On/Off]	Key switch status input from key slot
TURN SIGNAL R [On/Off]	Each switch status that BCM judges from the combination switch reading function
TURN SIGNAL L [On/Off]	
TAIL LAMP SW [On/Off]	
HI BEAM SW [On/Off]	
HEAD LAMP SW1 [On/Off]	
HEAD LAMP SW2 [On/Off]	
PASSING SW [On/Off]	
AUTO LIGHT SW [On/Off]	
FR FOG SW [On/Off]	
DOOR SW-DR [On/Off]	
DOOR SW-AS [On/Off]	The switch status input from front door switch (passenger side)
DOOR SW-RR [On/Off]	The switch status input from rear door switch RH
DOOR SW- RL [On/Off]	The switch status input from rear door switch LH



# DIAGNOSIS SYSTEM (BCM)

## < SYSTEM DESCRIPTION >

Monitor item [Unit]	Description
DOOR SW-BK [On/Off]	<b>NOTE:</b> The item is indicated, but not monitored.
OPTICAL SENSOR [V]	The value of exterior brightness voltage input from the optical sensor

## ACTIVE TEST

Test item	Operation	Description
TAIL LAMP	On	Transmits the position light request signal to IPDM E/R with CAN communication to turn the tail lamp ON.
	Off	Stops the position light request signal transmission.
HEAD LAMP	Hi	Transmits the high beam request signal with CAN communication to turn the headlamp (HI).
	Low	Transmits the low beam request signal with CAN communication to turn the headlamp (LO).
	Off	Stops the high & low beam request signal transmission.
FR FOG LAMP	On	Transmits the front fog light request signal to IPDM E/R with CAN communication to turn the front fog lamp ON.
	Off	Stops the front fog light request signal transmission.
RR FOG LAMP	On	<b>NOTE:</b> The item is indicated, but cannot be tested.
	Off	
CORNERING LAMP	RH	<b>NOTE:</b> The item is indicated, but cannot be tested.
	LH	
	Off	
ILL DIM SIGNAL	On	<b>NOTE:</b> The item is indicated, but cannot be tested.
	Off	

## WIPER

### WIPER : CONSULT Function (BCM - WIPER)

INFOID:000000007805101

## WORK SUPPORT

Service item	Setting item	Description
WIPER SPEED SETTING*1	On	With vehicle speed (Front wiper intermittent time linked with the vehicle speed and wiper intermittent dial position)
	Off*2	Without vehicle speed (Front wiper intermittent time linked with the wiper intermittent dial position)

\*1:For models without rain sensor.

\*2:Factory setting.

## DATA MONITOR

Monitor Item [Unit]	Description
PUSH SW [Off/On]	The switch status input from push-button ignition switch.
VEHICLE SPEED 1 [km/h]	The value of the vehicle speed signal received from unified meter and A/C amp. with CAN communication.

# DIAGNOSIS SYSTEM (BCM)

## < SYSTEM DESCRIPTION >

Monitor Item [Unit]	Description
FR WIPER HI [Off/On]	Each switch status that BCM judges from the combination switch reading function.
FR WIPER LOW [Off/On]	
FR WASHER SW [Off/On]	
FR WIPER INT [Off/On]	
FR WIPER STOP [Off/On]	Front wiper motor (stop position) status received from IPDM E/R with CAN communication.
INT VOLUME [1 - 7]	Each switch status that BCM judges from the combination switch reading function.
RR WIPER ON [Off/On]	Each switch status that BCM judges from the combination switch reading function.
RR WIPER INT [Off/On]	
RR WASHER SW [Off/On]	
RR WIPER STOP [Off/On]	Rear wiper motor (stop position) status input from the rear wiper motor.
H/L WASH SW [Off/On]	<b>NOTE:</b> The item is indicated, but not monitored.

## ACTIVE TEST

Test item	Operation	Description
FR WIPER	Hi	Transmits the front wiper request signal (HI) to IPDM E/R with CAN communication to operate the front wiper HI operation.
	Lo	Transmits the front wiper request signal (LO) to IPDM E/R with CAN communication to operate the front wiper LO operation.
	INT	Transmits the front wiper request signal (INT) to IPDM E/R with CAN communication to operate the front wiper INT operation.
	Off	Stops transmitting the front wiper request signal to stop the front wiper operation.
RR WIPER	On	Outputs the voltage to operate the rear wiper motor.
	Off	Stops the voltage to stop.

## FLASHER

### FLASHER : CONSULT Function (BCM - FLASHER)

INFOID:000000007806353

## WORK SUPPORT

Service item	Setting item	Setting	
HAZARD ANSWER BACK	Lock/Unlk*	With locking/unlocking	Sets the hazard warning lamp answer back function when the door is lock/unlock with the request switch or the key fob.
	Unlk Only	With unlocking only	
	Lock Only	With locking only	
	Off	Without the function	

\*: Factory setting

## DATA MONITOR

# DIAGNOSIS SYSTEM (BCM)

## < SYSTEM DESCRIPTION >

Monitor item [Unit]	Description
REQ SW-DR [On/Off]	The switch status input from the request switch (driver side)
REQ SW-AS [On/Off]	The switch status input from the request switch (passenger side)
PUSH SW [On/Off]	The switch status input from the push-button ignition switch
TURN SIGNAL R [On/Off]	Each switch condition that BCM judges from the combination switch reading function
TURN SIGNAL L [On/Off]	
HAZARD SW [On/Off]	The switch status input from the hazard switch
RKE-LOCK [On/Off]	Lock signal status received from the remote keyless entry receiver
RKE-UNLOCK [On/Off]	Unlock signal status received from the remote keyless entry receiver
RKE-PANIC [On/Off]	Panic alarm signal status received from the remote keyless entry receiver

## ACTIVE TEST

Test item	Operation	Description
FLASHER	Off	Stops the voltage to turn the turn signal lamps OFF.
	LH	Outputs the voltage to blink the left side turn signal lamps.
	RH	Outputs the voltage to blink the right side turn signal lamps.

## INTELLIGENT KEY

### INTELLIGENT KEY : CONSULT Function (BCM - INTELLIGENT KEY)

INFOID:000000007806410

## WORK SUPPORT

Monitor item	Description
REMO CONT ID CONFIR	It can be checked whether Intelligent Key ID code is registered or not in this mode.
AUTO LOCK SET	Auto door lock time can be changed in this mode. <ul style="list-style-type: none"> <li>• MODE 1: 1 min.</li> <li>• MODE 2: 5 min.</li> <li>• MODE 3: 30 sec.</li> <li>• MODE 4: 2 min.</li> </ul>
WELCOME LIGHT OP SET	Welcome light function mode can be changed to operate (WITH) or not operate (WITHOUT) in this mode.
LOCK/UNLOCK BY I-KEY	Door lock/unlock function by door request switch (driver side, passenger side and back door) mode can be changed to operate (WITH) or not operate (WITHOUT) in this mode.
ENGINE START BY I-KEY	Engine start function mode can be changed to operate (WITH) or not operate (WITHOUT) in this mode.
TRUNK/GLASS HATCH OPEN	Buzzer reminder function mode by back door request switch can be changed to operate (ON) or not operate (OFF) in this mode.
PANIC ALARM SET	Panic alarm button pressing time on Intelligent Key remote control button can be selected from the following in this mode. <ul style="list-style-type: none"> <li>• MODE 1: 0.5 sec.</li> <li>• MODE 2: Non-operational</li> <li>• MODE 3: 1.5 sec.</li> </ul>

A  
B  
C  
D  
E  
F  
G  
H  
I  
J  
K  
L

BCS

N  
O  
P

## DIAGNOSIS SYSTEM (BCM)

### < SYSTEM DESCRIPTION >

Monitor item	Description
PW DOWN SET	Unlock button pressing time on Intelligent Key button can be selected from the following in this mode. <ul style="list-style-type: none"> <li>• MODE 1: 3 sec.</li> <li>• MODE 2: Non-operational</li> <li>• MODE 3: 5 sec.</li> </ul>
TRUNK OPEN DELAY	<b>NOTE:</b> This item is displayed, but cannot be supported.
LO- BATT OF KEY FOB WARN	Intelligent Key low battery warning mode can be changed to operate (WITH) or not operate (WITHOUT) with this mode.
ANTI KEY LOCK IN FUNCTI	Key reminder function mode can be changed to operate (WITH) or not operate (WITHOUT) with this mode.
HAZARD ANSWER BACK	Hazard reminder function mode can be selected from the following in this mode. <ul style="list-style-type: none"> <li>• LOCK ONLY: Door lock operation only</li> <li>• UNLOCK ONLY: Door unlock operation only</li> <li>• LOCK/UNLOCK: Lock/unlock operation</li> <li>• OFF: Non-operational</li> </ul>
ANS BACK I-KEY LOCK	Buzzer reminder function (lock operation) mode by door request switch (driver side and passenger side) can be selected from the following in this mode. <ul style="list-style-type: none"> <li>• Horn chirp: Sound horn</li> <li>• Buzzer: Sound Intelligent Key warning buzzer</li> <li>• OFF: Non-operational</li> </ul>
ANS BACK I-KEY UNLOCK	Buzzer reminder function (unlock operation) mode by door request switch can be changed to operate (ON) or not operate (OFF) in this mode.
SHORT CRANKING OUTPUT	Starter motor can operate during the times below. <ul style="list-style-type: none"> <li>• 70 msec.</li> <li>• 100 msec.</li> <li>• 200 msec.</li> </ul>
INSIDE ANT DIAGNOSIS	This function allows inside key antenna self-diagnosis.
HORN WITH KEYLESS LOCK	Horn reminder function mode by Intelligent Key button can be changed to operate (ON) or not operate (OFF) in this mode.
WELCOME LIGHT SELECT	Welcome light function mode can be selected from the following in this mode. <ul style="list-style-type: none"> <li>• Puddle Lamp (ON/OFF)</li> <li>• Room Lamp (ON/OFF)</li> <li>• Head and Tail Lamps (This item is displayed, but cannot be supported.)</li> <li>• Outside Handle (This item is displayed, but cannot be supported.)</li> </ul>

### SELF-DIAG RESULT

Refer to [BCS-74, "DTC Index"](#).

### DATA MONITOR

Monitor Item	Condition
REQ SW -DR	Indicates [ON/OFF] condition of door request switch (driver side).
REQ SW -AS	Indicates [ON/OFF] condition of door request switch (passenger side).
REQ SW -BD/TR	Indicates [ON/OFF] condition of back door request switch.
PUSH SW	Indicates [ON/OFF] condition of push-button ignition switch.
IGN RLY2 -F/B	Indicates [ON/OFF] condition of ignition relay 2.
CLUCH SW	<b>NOTE:</b> This item is displayed, but cannot be monitored.
BRAKE SW 1	Indicates [ON/OFF] condition of brake switch.
DETE/CANCL SW	Indicates [ON/OFF] condition of the P position.
SFT PN/N SW	Indicates [ON/OFF] condition of the P or N position.
S/L -LOCK	<b>NOTE:</b> This item is displayed, but cannot be monitored.

# DIAGNOSIS SYSTEM (BCM)

## < SYSTEM DESCRIPTION >

Monitor Item	Condition
S/L -UNLOCK	<b>NOTE:</b> This item is displayed, but cannot be monitored.
S/L RELAY -F/B	<b>NOTE:</b> This item is displayed, but cannot be monitored.
UNLK SEN -DR	Indicates [ON/OFF] condition of driver door UNLOCK status.
PUSH SW -IPDM	Indicates [ON/OFF] condition of push-button ignition switch.
IGN RLY1 -F/B	Indicates [ON/OFF] condition of ignition relay 1.
DETE SW -IPDM	Indicates [ON/OFF] condition of the P position.
SFT PN -IPDM	Indicates [ON/OFF] condition of the P or N position.
SFT P -MET	Indicates [ON/OFF] condition of the P position.
SFT N -MET	Indicates [ON/OFF] condition of the N position.
ENGINE STATE	Indicates [STOP/START/CRANK/RUN] condition of engine states.
S/L LOCK-IPDM	<b>NOTE:</b> This item is displayed, but cannot be monitored.
S/L UNLK-IPDM	<b>NOTE:</b> This item is displayed, but cannot be monitored.
S/L RELAY-REQ	<b>NOTE:</b> This item is displayed, but cannot be monitored.
VEH SPEED 1	Displays the vehicle speed signal received from unified meter and A/C amp. by numerical value [Km/h].
VEH SPEED 2	Displays the vehicle speed signal received from ABS or VDC or CVT by numerical value [Km/h].
DOOR STAT-DR	Indicates [LOCK/READY/UNLOCK] condition of driver side door status.
DOOR STAT-AS	Indicates [LOCK/READY/UNLOCK] condition of passenger side door status.
ID OK FLAG	Indicates [SET/RESET] condition of key ID.
PRMT ENG STRT	Indicates [SET/RESET] condition of engine start possibility.
PRMT RKE STRT	<b>NOTE:</b> This item is displayed, but cannot be monitored.
KEY SW -SLOT	Indicates [ON/OFF] condition of key slot.
TRNK/HAT MNTR	<b>NOTE:</b> This item is displayed, but cannot be monitored.
RKE-LOCK	Indicates [ON/OFF] condition of LOCK signal from Intelligent Key.
RKE-UNLOCK	Indicates [ON/OFF] condition of UNLOCK signal from Intelligent Key.
RKE-TR/BD	<b>NOTE:</b> This item is displayed, but cannot be monitored.
RKE-PANIC	Indicates [ON/OFF] condition of PANIC button of Intelligent Key.
RKE-P/W OPEN	Indicates [ON/OFF] condition of P/W DOWN signal from Intelligent Key.
RKE-MODE CHG	Indicates [ON/OFF] condition of MODE CHANGE signal from Intelligent Key.
RKE OPE COUN1	When remote keyless entry receiver receives the signal transmitted while operating on Intelligent Key, the numerical values starts changing.
RKE OPE COUN2	<b>NOTE:</b> This item is displayed, but cannot be monitored.

## ACTIVE TEST

Test item	Description
BATTERY SAVER	This test is able to check interior room lamp operation. The interior room lamp is activated when "ON" on CONSULT screen is touched.
PW REMOTO DOWN SET	This test is able to check power window down operation. The power window down is activated when "ON" on CONSULT screen is touched.

# DIAGNOSIS SYSTEM (BCM)

## < SYSTEM DESCRIPTION >

Test item	Description
OUTSIDE BUZZER	This test is able to check Intelligent Key warning buzzer operation. The Intelligent Key warning buzzer is activated when "ON" on CONSULT screen is touched.
INSIDE BUZZER	This test is able to check warning chime in combination meter operation. <ul style="list-style-type: none"> <li>• Takes away warning chime sounds when "TAKE OUT" on CONSULT screen is touched.</li> <li>• Key warning chime sounds when "KEY" on CONSULT screen is touched.</li> <li>• The P position warning chime sounds when "KNOB" on CONSULT screen is touched.</li> </ul>
INDICATOR	This test is able to check warning lamp operation. <ul style="list-style-type: none"> <li>• "KEY" Warning lamp illuminates when "RED ON" on CONSULT screen is touched.</li> <li>• The "KEY" Warning lamp blinks when "RED IND" on CONSULT screen is touched.</li> </ul>
INT LAMP	This test is able to check interior room lamp operation. The interior room lamp is activated when "ON" on CONSULT screen is touched.
LCD	This test is able to check meter display information <ul style="list-style-type: none"> <li>• Engine start information displays when "BP N" on CONSULT screen is touched.</li> <li>• Engine start information displays when "BP I" on CONSULT screen is touched.</li> <li>• Key ID warning displays when "ID NG" on CONSULT screen is touched.</li> <li>• ROTAT: This item is displayed, but cannot be tasted.</li> <li>• The P position warning displays when "SFT P" on CONSULT screen is touched.</li> <li>• Intelligent Key insert information displays when "INSRT" on CONSULT screen is touched.</li> <li>• Intelligent Key low battery warning displays when "BATT" on CONSULT screen is touched.</li> <li>• Take away through window warning displays when "NO KY" on CONSULT screen is touched.</li> <li>• Take away warning displays when "OUTKY" on CONSULT screen is touched.</li> <li>• The OFF position warning displays when "LK WN" on CONSULT screen is touched.</li> </ul>
TRUNK/GLASS HATCH	<b>NOTE:</b> This item is displayed, but cannot be used.
FLASHER	This test is able to check security hazard lamp operation. The hazard lamps is activated when "LH" or "RH" on CONSULT screen is touched.
HORN	This test is able to check horn operation. The horn will be activated when "ON" on CONSULT screen is touched.
P RANGE	This test is able to check A/T shift selector power supply A/T shift selector power is supplied when "ON" on CONSULT screen is touched.
ENGINE SW ILLUMI	This test is able to check push-ignition switch illumination operation. Push-ignition switch illumination illuminates when "ON" on CONSULT screen is touched.
LOCK INDICATOR	This test is able to check indicator in push-ignition switch operation. Indicator in push-ignition switch (LOCK) illuminates when "ON" on CONSULT screen is touched.
ACC INDICATOR	This test is able to check indicator in push-ignition switch operation. Indicator in push-ignition switch (ACC) illuminates when "ON" on CONSULT screen is touched.
IGNITION ON IND	This test is able to check indicator in push-ignition switch operation. Indicator in push-ignition switch (ON) illuminates when "ON" on CONSULT screen is touched.
KEY SLOT ILLUMI	This test is able to check key slot illumination operation. Key slot illumination blinks when "ON" on CONSULT screen is touched.

## COMB SW

### COMB SW : CONSULT Function (BCM - COMB SW)

INFOID:000000007514212

## DATA MONITOR

Monitor item [UNIT]	Description
FR WIPER HI [Off/On]	Displays the status of the FR WIPER HI switch in combination switch judged by BCM with the combination switch reading function.
FR WIPER LOW [Off/On]	Displays the status of the FR WIPER LOW switch in combination switch judged by BCM with the combination switch reading function.
FR WASHER SW [Off/On]	Displays the status of the FR WASHER switch in combination switch judged by BCM with the combination switch reading function.
FR WIPER INT [Off/On]	Displays the status of the FR WIPER INT switch in combination switch judged by BCM with the combination switch reading function.

# DIAGNOSIS SYSTEM (BCM)

## < SYSTEM DESCRIPTION >

Monitor item [UNIT]	Description	
FR WIPER STOP [Off/On]	Displays the status of the front wiper stop position signal received from IPDM E/R via CAN communication.	A
INT VOLUME [1 - 7]	Displays the status of wiper volume dial position judged by BCM with the combination switch reading function.	B
RR WIPER ON [Off/On]	Displays the status of the RR WIPER ON switch in combination switch judged by BCM with the combination switch reading function.	C
RR WIPER INT [Off/On]	Displays the status of the RR WIPER INT switch in combination switch judged by BCM with the combination switch reading function.	C
RR WASHER SW [Off/On]	Displays the status of the RR WASHER switch in combination switch judged by BCM with the combination switch reading function.	D
RR WIPER STOP [Off/On]	Displays the status of the rear wiper stop position signal received from rear wiper motor.	E
TURN SIGNAL R [Off/On]	Displays the status of the TURN RH switch in combination switch judged by BCM with the combination switch reading function.	E
TURN SIGNAL L [Off/On]	Displays the status of the TURN LH switch in combination switch judged by BCM with the combination switch reading function.	F
TAIL LAMP SW [Off/On]	Displays the status of the TAIL LAMP switch in combination switch judged by BCM with the combination switch reading function.	F
HI BEAM SW [Off/On]	Displays the status of the HI BEAM switch in combination switch judged by BCM with the combination switch reading function.	G
HEAD LAMP SW 1 [Off/On]	Displays the status of the HEADLAMP 1 switch in combination switch judged by BCM with the combination switch reading function.	H
HEAD LAMP SW 2 [Off/On]	Displays the status of the HEADLAMP 2 switch in combination switch judged by BCM with the combination switch reading function.	H
PASSING SW [Off/On]	Displays the status of the PASSING switch in combination switch judged by BCM with the combination switch reading function.	I
AUTO LIGHT SW [Off/On]	Displays the status of the AUTO LIGHT switch in combination switch judged by BCM with the combination switch reading function.	J
FR FOG SW [Off/On]	Displays the status of the FR FOG switch in combination switch judged by BCM with the combination switch reading function.	J
RR FOG SW [Off/On]	<b>NOTE:</b> The item is indicated, but not monitored.	K

## BCM

### BCM : CONSULT Function (BCM - BCM)

INFOID:000000007514213

## WORK SUPPORT

BCS

Item	Description	
RESET SETTING VALUE	Return a value set with Work Support of each system to a default value in factory shipment.	N

## IMMU

### IMMU : CONSULT-III Function (BCM - IMMU)

INFOID:000000007514214

## DATA MONITOR

P

# DIAGNOSIS SYSTEM (BCM)

## < SYSTEM DESCRIPTION >

Monitor item	Content
CONFIRM ID ALL	Indicates [YET] at all time. Switches to [DONE] when a registered Intelligent Key is inserted into the key slot.
CONFIRM ID4	
CONFIRM ID3	
CONFIRM ID2	
CONFIRM ID1	
TP 4	Indicates the number of ID which has been registered.
TP 3	
TP 2	
TP 1	
PUSH SW	Indicates [ON/OFF] condition of push-button ignition switch.
KEY SW -SLOT	Indicates [ON/OFF] condition of key slot.

## ACTIVE TEST

Test item	Description
THEFT IND	This test is able to check security indicator lamp operation. The lamp will be turned on when "ON" on CONSULT-III screen touched.

## BATTERY SAVER

### BATTERY SAVER : CONSULT Function (BCM - BATTERY SAVER)

INFOID:000000007806362

## WORK SUPPORT

Service item	Setting item	Setting
ROOM LAMP BAT SAV SET	On*	With the interior room lamp battery saver function
	Off	Without the interior room lamp battery saver function
ROOM LAMP TIMER SET	MODE 1	30 min.
	MODE 2	60 min.
	MODE 3*	15 min.
BATTERY SAVER SET	On*	With the exterior lamp battery saver function
	Off	Without the exterior lamp battery saver function

\*: Factory setting

## DATA MONITOR

Monitor item [Unit]	Description
REQ SW-DR [On/Off]	The switch status input from request switch (driver side)
REQ SW-AS [On/Off]	The switch status input from request switch (passenger side)
REQ SW-RR [On/Off]	<b>NOTE:</b> The item is indicated, but not monitored.
REQ SW-RL [On/Off]	
PUSH SW [On/Off]	The switch status input from push-button ignition switch
UNLK SEN-DR [On/Off]	Driver door unlock status input from unlock sensor



# DIAGNOSIS SYSTEM (BCM)

## < SYSTEM DESCRIPTION >

Monitor item [Unit]	Description
KEY SW-SLOT [On/Off]	Key switch status input from key slot
DOOR SW-DR [On/Off]	The switch status input from front door switch (driver side)
DOOR SW-AS [On/Off]	The switch status input from front door switch (passenger side)
DOOR SW-RR [On/Off]	The switch status input from rear door switch (RH)
DOOR SW- RL [On/Off]	The switch status input from rear door switch (LH)
DOOR SW-BK [On/Off]	The switch status input from back door switch
CDL LOCK SW [On/Off]	Lock switch status received from central door lock/unlock switch by power window switch serial link
CDL UNLOCK SW [On/Off]	Unlock switch status received from central door lock/unlock switch by power window switch serial link
KEY CYL LK-SW [On/Off]	Lock switch status received from key cylinder lock/unlock switch by power window switch serial link
KEY CYL UN-SW [On/Off]	Unlock switch status received from key cylinder lock/unlock switch by power window switch serial link
TRNK/HAT MNTR [On/Off]	The switch status input from trunk room lamp switch
RKE-LOCK [On/Off]	Lock signal status received from remote keyless entry receiver
RKE-UNLOCK [On/Off]	Unlock signal status received from remote keyless entry receiver

## ACTIVE TEST

Test item	Operation	Description
BATTERY SAVER	Off	Cuts the interior room lamp power supply (battery saver signal).
	On	Provides the interior room lamp power supply (battery saver signal).

## TRUNK

### TRUNK : CONSULT Function (BCM - TRUNK)

INFOID:000000007806411

BCS

#### BCM CONSULT FUNCTION

CONSULT performs the following functions via CAN communication with BCM.

Diagnosis mode	Function Description
DATA MONITOR	The BCM input/output signals are displayed.
ACTIVE TEST	The signals used to activate each device are forcibly supplied from BCM.

#### DATA MONITOR

Monitor Item	Contents
PUSH SW	Indicates [ON/OFF] condition of push-button ignition switch.
UNLK SEN -DR	<b>NOTE:</b> This item is displayed, but cannot be monitored.
VEH SPEED 1	Indicates [Km/h] condition of vehicle speed signal from combination meter.
KEY CYL SW-TR	<b>NOTE:</b> This item is displayed, but cannot be monitored.

# DIAGNOSIS SYSTEM (BCM)

## < SYSTEM DESCRIPTION >

Monitor Item	Contents
TR CANCEL SW	<b>NOTE:</b> This item is displayed, but cannot be monitored.
TR/BD OPEN SW	Indicates [ON/OFF] condition of back door opener switch.
TRNK/HAT MNTR	<b>NOTE:</b> This item is displayed, but cannot be monitored.
RKE-TR/BD*	<b>NOTE:</b> This item is displayed, but cannot be monitored.

\*: With back door opener system

## ACTIVE TEST

Test item	Description
TRUNK/GLASS HATCH	<b>NOTE:</b> This item is displayed, but cannot be used.

## THEFT ALM

### THEFT ALM : CONSULT Function (BCM - THEFT ALM)

INFOID:000000007805102

## DATA MONITOR

Monitored Item	Description
REQ SW -DR	Indicates [ON/OFF] condition of door request switch (driver side).
REQ SW -AS	Indicates [ON/OFF] condition of door request switch (passenger side).
REQ SW -RR	<b>NOTE:</b> This is displayed even when it is not equipped.
REQ SW -RL	<b>NOTE:</b> This is displayed even when it is not equipped.
REQ SW -BD/TR	Indicates [ON/OFF] condition of back door request switch.
PUSH SW	Indicates [ON/OFF] condition of push-button ignition switch
UNLK SEN -DR	Indicates [ON/OFF] condition of driver door UNLOCK status.
KEY SW -SLOT	Indicates [ON/OFF] condition of key slot.
DOOR SW-DR	Indicates [ON/OFF] condition of front door switch LH.
DOOR SW-AS	Indicates [ON/OFF] condition of front door switch RH.
DOOR SW-RR	Indicates [ON/OFF] condition of rear door switch RH.
DOOR SW-RL	Indicates [ON/OFF] condition of rear door switch LH.
DOOR SW-BK	Indicates [ON/OFF] condition of back door switch.
CDL LOCK SW	Indicates [ON/OFF] condition of lock signal from door lock/unlock switch LH and RH.
CDL UNLOCK SW	Indicates [ON/OFF] condition of unlock signal from door lock/unlock switch LH and RH.
KEY CYL LK-SW	Indicates [ON/OFF] condition of lock signal from front door key cylinder switch.
KEY CYL UN-SW	Indicates [ON/OFF] condition of unlock signal from front door key cylinder switch.
KEY CYL SW-TR	<b>NOTE:</b> This is displayed even when it is not equipped.
TR/BD OPEN SW	Indicates [ON/OFF] condition of back door opener switch.
TRNK/HAT MNTR	<b>NOTE:</b> This is displayed even when it is not equipped.
RKE-LOCK	Indicates [ON/OFF] condition of LOCK signal from Intelligent Key.
RKE-UNLOCK	Indicates [ON/OFF] condition of UNLOCK signal from Intelligent Key.
RKE-TR/BD	<b>NOTE:</b> This is displayed even when it is not equipped.

# DIAGNOSIS SYSTEM (BCM)

< SYSTEM DESCRIPTION >

## WORK SUPPORT

Test Item	Description
SECURITY ALARM SET	This mode is able to confirm and change security alarm ON-OFF setting.
THEFT ALM TRG	The switch which triggered vehicle security alarm is recorded. This mode is able to confirm and erase the record of vehicle security alarm. The trigger data can be erased by touching "CLEAR" on CONSULT screen.

## ACTIVE TEST

Test Item	Description
THEFT IND	This test is able to check security indicator lamp operation. The lamp will be turned on when "ON" on CONSULT screen is touched.
VEHICLE SECURITY HORN	This test is able to check vehicle security horn operation. The horns will be activated for 0.5 seconds after "ON" on CONSULT screen is touched.
HEADLAMP(HI)	This test is able to check vehicle security lamp operation. The headlamps will be activated for 0.5 seconds after "ON" on CONSULT screen is touched.
FLASHER	This test is able to check vehicle security hazard lamp operation. The hazard lamps will be activated after "LH" or "RH" on CONSULT screen is touched.

## RETAINED PWR

### RETAINED PWR : CONSULT Function (BCM - RETAINED PWR)

INFOID:000000007805103

#### Data monitor

Monitor Item	Description
DOOR SW-DR	Indicates [ON/OFF] condition of driver side door switch.
DOOR SW-AS	Indicates [ON/OFF] condition of passenger side door switch.

## SIGNAL BUFFER

### SIGNAL BUFFER : CONSULT Function (BCM - SIGNAL BUFFER)

INFOID:000000007514220

#### DATA MONITOR

Monitor item [UNIT]	Description
PUSH SW [Off/On]	Displays the status of the push-button ignition switch (push switch) judged by BCM.

## ACTIVE TEST

Test item	Operation	Description
OIL PRESSURE SW	Off	OFF
	On	BCM transmits the oil pressure switch signal to the unified meter and A/C amp. via CAN communication, which illuminates the oil pressure warning lamp in the combination meter.

A  
B  
C  
D  
E  
F  
G  
H  
I  
J  
K  
L  
N  
O  
P

BCS

# U1000 CAN COMM

< DTC/CIRCUIT DIAGNOSIS >

## DTC/CIRCUIT DIAGNOSIS

### U1000 CAN COMM

#### Description

INFOID:000000007514221

CAN (Controller Area Network) is a serial communication line for real time applications. It is an on-vehicle multiplex communication line with high data communication speed and excellent error detection ability. Modern vehicle is equipped with many electronic control unit, and each control unit shares information and links with other control units during operation (not independent). In CAN communication, control units are connected with 2 communication lines (CAN H-line, CAN L-line) allowing a high rate of information transmission with less wiring. Each control unit transmits/receives data but selectively reads required data only.  
CAN Communication Signal Chart. Refer to [LAN-31, "CAN Communication Signal Chart"](#).

#### DTC Logic

INFOID:000000007514222

#### DTC DETECTION LOGIC

DTC	CONSULT display description	DTC Detection Condition	Possible cause
U1000	CAN COMM	When BCM cannot communicate CAN communication signal continuously for 2 seconds or more.	CAN communication system

#### Diagnosis Procedure

INFOID:000000007514223

#### 1. PERFORM SELF DIAGNOSTIC

1. Turn ignition switch ON and wait for 2 seconds or more.
2. Check "Self Diagnostic Result".

Is DTC "U1000" displayed?

- YES >> Refer to [LAN-21, "Trouble Diagnosis Flow Chart"](#).  
NO >> Refer to [GI-45, "Intermittent Incident"](#).

# U1010 CONTROL UNIT (CAN)

< DTC/CIRCUIT DIAGNOSIS >

## U1010 CONTROL UNIT (CAN)

### DTC Logic

INFOID:000000007514224

### DTC DETECTION LOGIC

DTC	CONSULT display de- scription	DTC Detection Condition	Possible cause
U1010	CONTROL UNIT(CAN)	BCM detected internal CAN communication circuit malfunction.	BCM

### Diagnosis Procedure

INFOID:000000007514225

#### 1. REPLACE BCM

When DTC "U1010" is detected, replace BCM.

>> Replace BCM. Refer to [BCS-79. "Exploded View"](#).

A  
B  
C  
D  
E  
F  
G  
H  
I  
J  
K  
L

BCS

N  
O  
P

# U0415 VEHICLE SPEED SIG

< DTC/CIRCUIT DIAGNOSIS >

## U0415 VEHICLE SPEED SIG

### Description

INFOID:000000007514226

U0415 is displayed if any unusual condition is present in the reception status of the vehicle speed signal from the ABS actuator and electric unit (control unit).

### DTC Logic

INFOID:000000007514227

### DTC DETECTION LOGIC

DTC	CONSULT display description	DTC Detection Condition	Probable cause
U0415	VEHICLE SPEED	When the vehicle speed signal received from the ABS actuator and electric unit (control unit) remains abnormal for 2 seconds or more.	<ul style="list-style-type: none"><li>• ABS actuator and electric unit (control unit)</li><li>• BCM</li></ul>

### DTC CONFIRMATION PROCEDURE

#### 1. DTC CONFIRMATION

1. Erase the DTC.
2. Turn ignition switch OFF.
3. Perform the "Self Diagnostic Result" of CONSULT, when passed 2 seconds or more after the ignition switch is turned ON.

#### Is any DTC detected?

- YES >> Refer to [BCS-38, "Diagnosis Procedure"](#).  
NO >> INSPECTION END

### Diagnosis Procedure

INFOID:000000007514228

#### 1. ABS ACTUATOR AND ELECTRIC UNIT (CONTROL UNIT) SELF-DIAG RESULTS

Perform "Self-Diagnostic Result" of ABS actuator and electric unit (control unit) with CONSULT. Refer to [BRC-44, "CONSULT Function"](#).

#### Is any DTC detected?

- YES >> Repair or replace the malfunctioning part.  
NO >> Replace BCM. Refer to [BCS-79, "Exploded View"](#).

# B2562 LOW VOLTAGE

< DTC/CIRCUIT DIAGNOSIS >

## B2562 LOW VOLTAGE

### DTC Logic

INFOID:000000007514229

### DTC DETECTION LOGIC

DTC	CONSULT display description	DTC Detection Condition	Possible cause
B2562	LOW VOLTAGE	When the power supply voltage to BCM remains less than 8.8 V for 120 seconds or more	Harness or connector (power supply circuit)

### DTC CONFIRMATION PROCEDURE

#### 1. DTC CONFIRMATION

1. Erase DTC.
2. Turn ignition switch OFF.
3. Perform the "Self Diagnostic Result" of CONSULT, when passed 120 seconds or more after the ignition switch is turned ON.

#### Is any DTC detected?

- YES >> Refer to [BCS-39, "Diagnosis Procedure"](#).  
NO >> INSPECTION END

### Diagnosis Procedure

INFOID:000000007514230

#### 1. CHECK POWER SUPPLY CIRCUIT

Check BCM power supply circuit. Refer to [BCS-41, "Diagnosis Procedure"](#).

#### Is the circuit normal?

- YES >> Replace BCM. Refer to [BCS-79, "Exploded View"](#).  
NO >> Repair the malfunctioning part.

A  
B  
C  
D  
E  
F  
G  
H  
I  
J  
K  
L

BCS

N  
O  
P

# B26E7 TPMS CAN COMM

< DTC/CIRCUIT DIAGNOSIS >

## B26E7 TPMS CAN COMM

### DTC Logic

INFOID:000000007514231

### DTC DETECTION LOGIC

DTC	CONSULT display description	DTC Detection Condition	Probable cause
B26E7	TPMS CAN COMM	When ignition switch is ON, BCM cannot received CAN communication signal from low tire pressure warning control unit.	<ul style="list-style-type: none"><li>• CAN communication system</li><li>• Low tire pressure warning control unit</li><li>• BCM</li></ul>

### DTC CONFIRMATION PROCEDURE

#### 1. DTC CONFIRMATION

1. Erase the DTC.
2. Turn ignition switch OFF.
3. Perform the "Self Diagnostic Result" of CONSULT, when passed 2 seconds or more after the ignition switch is turned ON.

#### Is any DTC detected?

- YES >> Refer to [BCS-40, "Diagnosis Procedure"](#).  
NO >> INSPECTION END

### Diagnosis Procedure

INFOID:000000007514232

#### NOTE:

If DTC "B26E7" detected along with DTC "U1000", first diagnose the DTC "U1000". Refer to [BCS-36, "Diagnosis Procedure"](#).

#### 1. LOW TIRE PRESSURE WARNING CONTROL UNIT SELF DIAGNOSTIC RESULT

Perform "Self Diagnostic Result" of low tire pressure warning control unit with CONSULT. Refer to [BRC-44, "CONSULT Function"](#).

#### Is any DTC detected?

- YES >> GO TO 2.  
NO >> GO TO 4.

#### 2. LOW TIRE PRESSURE WARNING CONTROL UNIT DIAGNOSIS

Perform low tire pressure warning control unit component diagnosis of detected DTC. Refer to [BCS-74, "DTC Index"](#).

>> GO TO 3.

#### 3. BCM SELF DIAGNOSTIC RESULT

Erase DTC of BCM, and perform "Self Diagnostic Result" again.

#### Is DTC "B26E7" detected?

- YES >> Replace BCM. Refer to [BCS-79, "Exploded View"](#).  
NO >> INSPECTION END

#### 4. REPLACE LOW TIRE PRESSURE WARNING CONTROL UNIT TEMPORARILY

Remove low tire pressure warning control unit, and install normal low tire pressure warning control unit.

>> GO TO 5.

#### 5. BCM SELF-DIAGNOSTIC RESULT

Erase DTC of BCM, and perform "Self Diagnostic Result" again.

#### Is DTC "B26E7" detected?

- YES >> Replace BCM. Refer to [BCS-79, "Exploded View"](#).  
NO >> Replace low tire pressure warning control unit. Refer to [WT-62, "Exploded View"](#).



# POWER SUPPLY AND GROUND CIRCUIT

< DTC/CIRCUIT DIAGNOSIS >

## POWER SUPPLY AND GROUND CIRCUIT

### Diagnosis Procedure

INFOID:000000007514233

#### 1. CHECK FUSE AND FUSIBLE LINK

Check that the following fuse and fusible link are not blown.

Signal name	Fuse and fusible link No.
Battery power supply	L
	10

#### Is the fuse fusing?

YES >> Replace the blown fuse or fusible link after repairing the affected circuit if a fuse or fusible link is blown.

NO >> GO TO 2.

#### 2. CHECK POWER SUPPLY CIRCUIT

1. Turn ignition switch OFF.
2. Disconnect BCM connectors.
3. Check voltage between BCM harness connector and ground.

Terminals		Voltage (Approx.)
(+)	(-)	
BCM		Ground  Battery voltage
Connector	Terminal	
M118	1	
M119	11	

#### Is the measurement value normal?

YES >> GO TO 3.

NO >> Repair harness or connector.

#### 3. CHECK GROUND CIRCUIT

Check continuity between BCM harness connector and ground.

BCM		Ground	Continuity
Connector	Terminal		
M119	13		Existed

#### Does continuity exist?

YES >> INSPECTION END

NO >> Repair harness or connector.

A  
B  
C  
D  
E  
F  
G  
H  
I  
J  
K  
L  
N  
O  
P

BCS

# COMBINATION SWITCH INPUT CIRCUIT

< DTC/CIRCUIT DIAGNOSIS >

## COMBINATION SWITCH INPUT CIRCUIT

### Diagnosis Procedure

INFOID:000000007514234

#### 1. CHECK INPUT 1 - 5 SYSTEM CIRCUIT FOR OPEN

1. Turn the ignition switch OFF.
2. Disconnect the BCM and combination switch connectors.
3. Check continuity between BCM harness connector and combination switch harness connector.

System	BCM		Combination switch		Continuity
	Connector	Terminal	Connector	Terminal	
INPUT 1	M122	107	M33	11	Existed
INPUT 2		109		9	
INPUT 3		88		7	
INPUT 4		108		10	
INPUT 5		87		13	

Does continuity exist?

YES >> GO TO 2.

NO >> Repair the harnesses or connectors.

#### 2. CHECK INPUT 1 - 5 SYSTEM CIRCUIT FOR SHORT

Check for continuity between BCM harness connector and ground.

System	BCM		Ground	Continuity
	Connector	Terminal		
INPUT 1	M122	107	Ground	Not existed
INPUT 2		109		
INPUT 3		88		
INPUT 4		108		
INPUT 5		87		

Does continuity exist?

YES >> Repair the harnesses or connectors.

NO >> GO TO 3.

#### 3. CHECK BCM OUTPUT VOLTAGE

1. Connect the BCM connector.
2. Check voltage between BCM harness connector and ground.

System	Terminals		Ground	Voltage (Approx.)
	(+)	(-)		
	BCM			
	Connector	Terminal		
INPUT 1	M122	107	Ground	Refer to <a href="#">BCS-46, "Reference Value"</a> .
INPUT 2		109		
INPUT 3		88		
INPUT 4		108		
INPUT 5		87		

Is the measurement value normal?

YES >> GO TO 4.

NO >> Replace BCM. Refer to [BCS-79, "Exploded View"](#).

# COMBINATION SWITCH INPUT CIRCUIT

< DTC/CIRCUIT DIAGNOSIS >

## 4. CHECK BCM INPUT SIGNAL

1. Connect the combination switch connector.
2. Turn ON any switch in the system that is malfunctioning.
3. Check voltage between BCM harness connector and ground.

System	Terminals		Voltage (Approx.)	
	(+)	(-)		
	BCM			
	Connector	Terminal	Ground	Refer to <a href="#">BCS-46</a> . "Reference Value".
INPUT 1	M122	107		
INPUT 2		109		
INPUT 3		88		
INPUT 4		108		
INPUT 5		87		

Is the measurement value normal when any of the switches is turned ON?

- YES >> Replace BCM. Refer to [BCS-79](#). "Exploded View".  
 NO >> Replace the combination switch.

A  
B  
C  
D  
E  
F  
G  
H  
I  
J  
K  
L

BCS

N  
O  
P

# COMBINATION SWITCH OUTPUT CIRCUIT

< DTC/CIRCUIT DIAGNOSIS >

## COMBINATION SWITCH OUTPUT CIRCUIT

### Diagnosis Procedure

INFOID:000000007514235

#### 1. CHECK OUTPUT 1 - 5 SYSTEM CIRCUIT FOR OPEN

1. Turn the ignition switch OFF.
2. Disconnect the BCM and combination switch connectors.

**NOTE:**

BCM connector disconnects M123 only.

3. Check continuity between BCM harness connector and combination switch harness connector.

System	BCM		Combination switch		Continuity
	Connector	Terminal	Connector	Terminal	
OUTPUT 1	M123	143	M33	12	Existed
OUTPUT 2		144		14	
OUTPUT 3		145		5	
OUTPUT 4		146		2	
OUTPUT 5		142		8	

Does continuity exist?

YES >> GO TO 2.

NO >> Repair the harnesses or connectors.

#### 2. CHECK OUTPUT 1 - 5 SYSTEM CIRCUIT FOR SHORT

Check for continuity between BCM harness connector and ground.

System	BCM		Ground	Continuity
	Connector	Terminal		
OUTPUT 1	M123	143	Ground	Not existed
OUTPUT 2		144		
OUTPUT 3		145		
OUTPUT 4		146		
OUTPUT 5		142		

Does continuity exist?

YES >> Repair the harnesses or connectors.

NO >> GO TO 3.

#### 3. CHECK COMBINATION SWITCH INTERNAL CIRCUIT

1. Connect the combination switch connector.
2. Turn ON any switch in the system that is malfunctioning.
3. Check voltage between combination switch harness connector and ground.

**NOTE:**

Check that the combination switch outputs a signal from combination switch input system.

# COMBINATION SWITCH OUTPUT CIRCUIT

< DTC/CIRCUIT DIAGNOSIS >

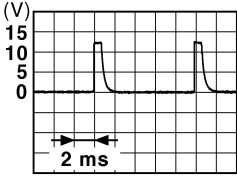
System	Terminals		Value (Approx.)
	(+)	(-)	
	Combination switch		
	Connector	Terminal	
OUTPUT 1	M33	12	 1.4 V
OUTPUT 2		14	
OUTPUT 3		5	
OUTPUT 4		2	
OUTPUT 5		8	

Is the measurement value normal when any of the switches is turned ON?

- YES >> Replace BCM. Refer to [BCS-79, "Exploded View"](#).
- NO >> Replace the combination switch.

A  
B  
C  
D  
E  
F  
G  
H  
I  
J  
K  
L  
N  
O  
P

BCS

# BCM (BODY CONTROL MODULE)

< ECU DIAGNOSIS INFORMATION >

## ECU DIAGNOSIS INFORMATION

### BCM (BODY CONTROL MODULE)

Reference Value

INFOID:000000007514236

VALUES ON THE DIAGNOSIS TOOL

CONSULT MONITOR ITEM

Monitor Item	Condition	Value/Status
FR WIPER HI	Other than front wiper switch HI	Off
	Front wiper switch HI	On
FR WIPER LOW	Other than front wiper switch LO	Off
	Front wiper switch LO	On
FR WASHER SW	Front washer switch OFF	Off
	Front washer switch ON	On
FR WIPER INT	Other than front wiper switch INT/AUTO	Off
	Front wiper switch INT/AUTO	On
FR WIPER STOP	Front wiper is not in STOP position	Off
	Front wiper is in STOP position	On
INT VOLUME	Wiper volume dial is in a dial position 1 - 7	Wiper volume dial position
RR WIPER ON	Other than rear wiper switch ON	Off
	Rear wiper switch ON	On
RR WIPER INT	Other than rear wiper switch INT	Off
	Rear wiper switch INT	On
RR WASHER SW	Rear washer switch OFF	Off
	Rear washer switch ON	On
RR WIPER STOP	Rear wiper is in STOP position	Off
	Rear wiper is not in STOP position	On
TURN SIGNAL R	Other than turn signal switch RH	Off
	Turn signal switch RH	On
TURN SIGNAL L	Other than turn signal switch LH	Off
	Turn signal switch LH	On
TAIL LAMP SW	Other than lighting switch 1ST and 2ND	Off
	Lighting switch 1ST or 2ND	On
HI BEAM SW	Other than lighting switch HI	Off
	Lighting switch HI	On
HEAD LAMP SW 1	Other than lighting switch 2ND	Off
	Lighting switch 2ND	On
HEAD LAMP SW 2	Other than lighting switch 2ND	Off
	Lighting switch 2ND	On
PASSING SW	Other than lighting switch PASS	Off
	Lighting switch PASS	On
AUTO LIGHT SW	Other than lighting switch AUTO	Off
	Lighting switch AUTO	On
FR FOG SW	Front fog lamp switch OFF	Off
	Front fog lamp switch ON	On

## BCM (BODY CONTROL MODULE)

### < ECU DIAGNOSIS INFORMATION >

Monitor Item	Condition	Value/Status	
RR FOG SW	<b>NOTE:</b> The item is indicated, but not monitored.	Off	A
DOOR SW-DR	Driver door closed	Off	B
	Driver door opened	On	
DOOR SW-AS	Passenger door closed	Off	C
	Passenger door opened	On	
DOOR SW-RR	Rear RH door closed	Off	D
	Rear RH door opened	On	
DOOR SW-RL	Rear LH door closed	Off	E
	Rear LH door opened	On	
DOOR SW-BK	Back door closed	Off	F
	Back door opened	On	
CDL LOCK SW	Other than power door lock switch LOCK	Off	G
	Power door lock switch LOCK	On	
CDL UNLOCK SW	Other than power door lock switch UNLOCK	Off	H
	Power door lock switch UNLOCK	On	
KEY CYL LK-SW	Other than driver door key cylinder LOCK position	Off	I
	Driver door key cylinder LOCK position	On	
KEY CYL UN-SW	Other than driver door key cylinder UNLOCK position	Off	J
	Driver door key cylinder UNLOCK position	On	
KEY CYL SW-TR	<b>NOTE:</b> The item is indicated, but not monitored.	Off	K
HAZARD SW	Hazard switch is OFF	Off	L
	Hazard switch is ON	On	
REAR DEF SW	<b>NOTE:</b> The item is indicated, but not monitored.	Off	
TR CANCEL SW	<b>NOTE:</b> The item is indicated, but not monitored.	Off	
TR/BD OPEN SW	Back door opener switch OFF	Off	BCS
	While the back door opener switch is turned ON	On	
TRNK/HAT MNTR	<b>NOTE:</b> The item is indicated, but not monitored.	Off	
REVERSE SW	<b>NOTE:</b> The item is indicated, but not monitored.	Off	
RKE-LOCK	LOCK button of the Intelligent Key is not pressed	Off	N
	LOCK button of the Intelligent Key is pressed	On	
RKE-UNLOCK	UNLOCK button of the Intelligent Key is not pressed	Off	O
	UNLOCK button of the Intelligent Key is pressed	On	
RKE-TR/BD	<b>NOTE:</b> The item is indicated, but not monitored.	Off	
RKE-PANIC	PANIC button of the Intelligent Key is not pressed	Off	P
	PANIC button of the Intelligent Key is pressed	On	
RKE-P/W OPEN	UNLOCK button of the Intelligent Key is not pressed	Off	
	UNLOCK button of the Intelligent Key is pressed and held	On	
RKE-MODE CHG	LOCK/UNLOCK button of the Intelligent Key is not pressed and held simultaneously	Off	
	LOCK/UNLOCK button of the Intelligent Key is pressed and held simultaneously	On	

## BCM (BODY CONTROL MODULE)

### < ECU DIAGNOSIS INFORMATION >

Monitor Item	Condition	Value/Status
OPTICAL SENSOR	Bright outside of the vehicle	Close to 5 V
	Dark outside of the vehicle	Close to 0 V
REQ SW -DR	Driver door request switch is not pressed	Off
	Driver door request switch is pressed	On
REQ SW -AS	Passenger door request switch is not pressed	Off
	Passenger door request switch is pressed	On
REQ SW -RR	<b>NOTE:</b> The item is indicated, but not monitored.	Off
REQ SW -RL	<b>NOTE:</b> The item is indicated, but not monitored.	Off
REQ SW -BD/TR	Back door request switch is not pressed	Off
	Back door request switch is pressed	On
PUSH SW	Push-button ignition switch (push switch) is not pressed	Off
	Push-button ignition switch (push switch) is pressed	On
IGN RLY2 -F/B	<b>NOTE:</b> The item is indicated, but not monitored.	Off
ACC RLY -F/B	<b>NOTE:</b> The item is indicated, but not monitored.	Off
CLUCH SW	<b>NOTE:</b> The item is indicated, but not monitored.	Off
BRAKE SW 1	The brake pedal is depressed when No. 7 fuse is blown	Off
	The brake pedal is not depressed when No. 7 fuse is blown, or No. 7 fuse is normal	On
BRAKE SW 2	The brake pedal is not depressed	Off
	The brake pedal is depressed	On
DETE/CANCL SW	Selector lever in P position	Off
	Selector lever in any position other than P	On
SFT PN/N SW	Selector lever in any position other than P and N	Off
	Selector lever in P or N position	On
S/L -LOCK	<b>NOTE:</b> The item is indicated but not monitored.	Off
S/L -UNLOCK	<b>NOTE:</b> The item is indicated but not monitored.	Off
S/L RELAY-F/B	<b>NOTE:</b> The item is indicated but not monitored.	Off
UNLK SEN -DR	Driver door is unlocked	Off
	Driver door is locked	On
PUSH SW -IPDM	Push-button ignition switch (push-switch) is not pressed	Off
	Push-button ignition switch (push-switch) is pressed	On
IGN RLY1 -F/B	Ignition switch in OFF or ACC position	Off
	Ignition switch in ON position	On
DETE SW -IPDM	Selector lever in any position other than P	Off
	Selector lever in P position	On
SFT PN -IPDM	Selector lever in any position other than P and N	Off
	Selector lever in P or N position	On
SFT P -MET	Selector lever in any position other than P	Off
	Selector lever in P position	On



## BCM (BODY CONTROL MODULE)

### < ECU DIAGNOSIS INFORMATION >

Monitor Item	Condition	Value/Status	
SFT N -MET	Selector lever in any position other than N	Off	A
	Selector lever in N position	On	
ENGINE STATE	Engine stopped	Stop	B
	While the engine stalls	Stall	
	At engine cranking	Crank	C
	Engine running	Run	
S/L LOCK-IPDM	<b>NOTE:</b> The item is indicated but not monitored.	Off	D
S/L UNLK-IPDM	<b>NOTE:</b> The item is indicated but not monitored.	Off	
S/L RELAY-REQ	<b>NOTE:</b> The item is indicated but not monitored.	Off	E
VEH SPEED 1	While driving	Equivalent to speedometer reading	
VEH SPEED 2	While driving	Equivalent to speedometer reading	F
DOOR STAT-DR	Driver door is locked	LOCK	G
	Wait with selective UNLOCK operation (5 seconds)	READY	
	Driver door is unlocked	UNLOCK	
DOOR STAT-AS	Passenger door is locked	LOCK	H
	Wait with selective UNLOCK operation (5 seconds)	READY	
	Passenger door is unlocked	UNLOCK	
ID OK FLAG	Driver side door is open after ignition switch is turned OFF (Selector lever is in the P position)	Reset	I
	Ignition switch ON	Set	
PRMT ENG STRT	The engine start is prohibited	Reset	J
	The engine start is permitted	Set	
PRMT RKE STRT	<b>NOTE:</b> The item is indicated, but not monitored.	Reset	K
KEY SW -SLOT	The Intelligent Key is not inserted into key slot	Off	L
	The Intelligent Key is inserted into key slot	On	
RKE OPE COUN1	During the operation of the Intelligent Key	Operation frequency of the Intelligent Key	
RKE OPE COUN2	<b>NOTE:</b> The item is indicated, but not monitored.	—	BCS
CONFIRM ID ALL	The key ID that the key slot receives is not recognized by any key ID registered to BCM.	Yet	N
	The key ID that the key slot receives accords with any key ID registered to BCM.	Done	
CONFIRM ID4	The key ID that the key slot receives is not recognized by the fourth key ID registered to BCM.	Yet	O
	The key ID that the key slot receives is recognized by the fourth key ID registered to BCM.	Done	
CONFIRM ID3	The key ID that the key slot receives is not recognized by the third key ID registered to BCM.	Yet	P
	The key ID that the key slot receives is recognized by the third key ID registered to BCM.	Done	

## BCM (BODY CONTROL MODULE)

### < ECU DIAGNOSIS INFORMATION >

Monitor Item	Condition	Value/Status
CONFIRM ID2	The key ID that the key slot receives is not recognized by the second key ID registered to BCM.	Yet
	The key ID that the key slot receives is recognized by the second key ID registered to BCM.	Done
CONFIRM ID1	The key ID that the key slot receives is not recognized by the first key ID registered to BCM.	Yet
	The key ID that the key slot receives is recognized by the first key ID registered to BCM.	Done
TP 4	The ID of fourth Intelligent Key is not registered to BCM	Yet
	The ID of fourth Intelligent Key is registered to BCM	Done
TP 3	The ID of third Intelligent Key is not registered to BCM	Yet
	The ID of third Intelligent Key is registered to BCM	Done
TP 2	The ID of second Intelligent Key is not registered to BCM	Yet
	The ID of second Intelligent Key is registered to BCM	Done
TP 1	The ID of first Intelligent Key is not registered to BCM	Yet
	The ID of first Intelligent Key is registered to BCM	Done

# BCM (BODY CONTROL MODULE)

< ECU DIAGNOSIS INFORMATION >

## TERMINAL LAYOUT

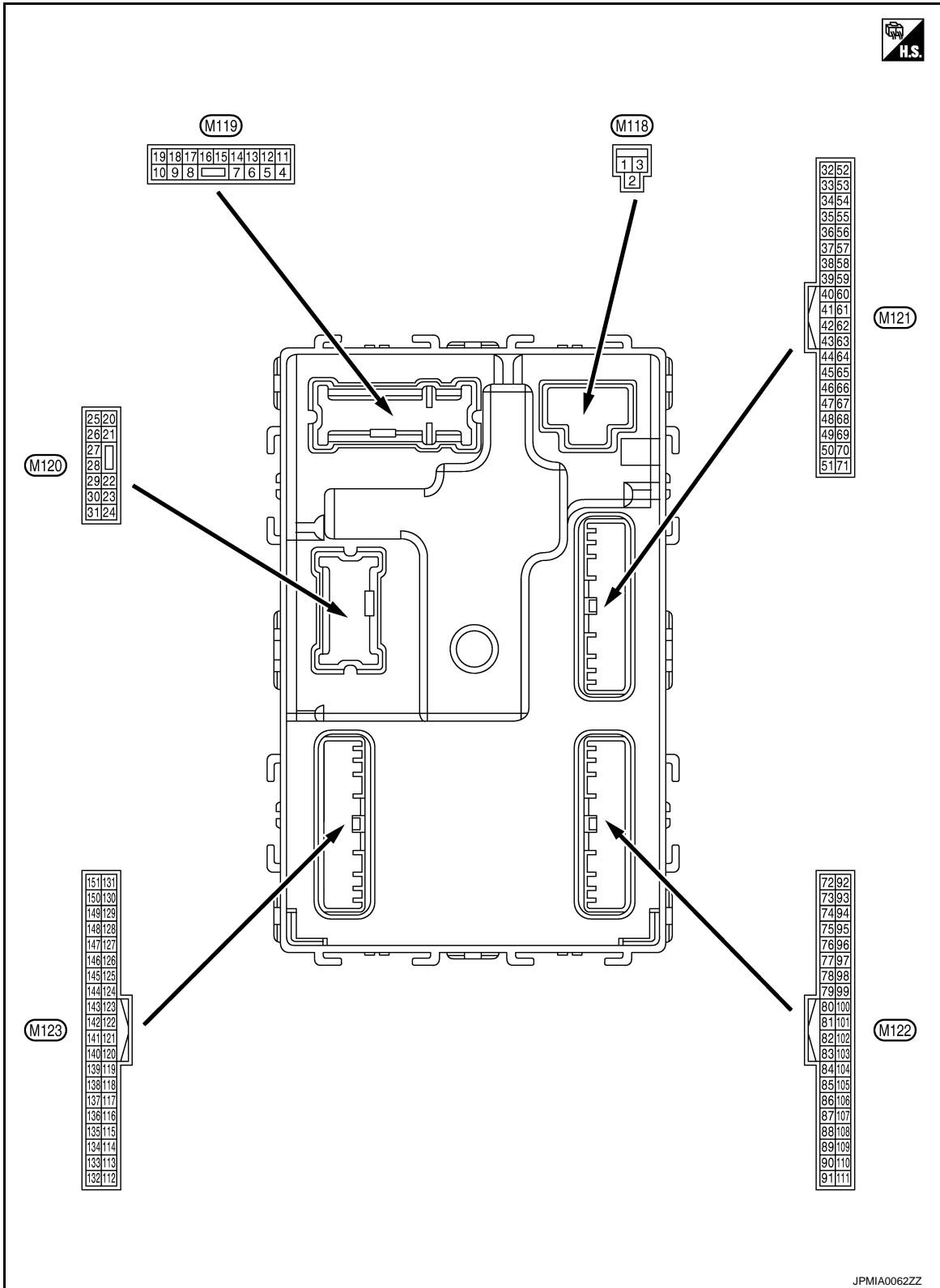

PHYSICAL VALUES

A  
B  
C  
D  
E  
F  
G  
H  
I  
J  
K  
L  
M  
N  
O  
P

BCS

# BCM (BODY CONTROL MODULE)

## < ECU DIAGNOSIS INFORMATION >

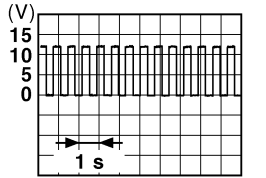
Terminal No. (Wire color)		Description		Condition		Value (Approx.)
+	-	Signal name	Input/ Output			
1 (W)	Ground	Battery power supply	Input	Ignition switch OFF		Battery voltage
2 (Y)	Ground	P/W power supply (BAT)	Output	Ignition switch OFF		12 V
3 (BG)	Ground	P/W power supply (IGN)	Output	Ignition switch ON		12 V
4 (P)	Ground	Interior room lamp power supply	Output	Interior room lamp battery saver is activated. (Cuts the interior room lamp power supply)		0 V
				Interior room lamp battery saver is not activated. (Outputs the interior room lamp power supply)		12 V
5 (V)	Ground	Passenger door UN- LOCK	Output	Passenger door	UNLOCK (Actuator is activated)	12 V
					Other than UNLOCK (Actuator is not activated)	0 V
7 (Y)	Ground	Step lamp control	Output	Step lamp	ON	0 V
					OFF	12 V
8 (V)	Ground	All doors, fuel lid LOCK	Output	All doors, fuel lid	LOCK (Actuator is activated)	12 V
					Other than LOCK (Actuator is not activated)	0 V
9 (G)	Ground	Driver door, fuel lid UNLOCK	Output	Driver door, fuel lid	UNLOCK (Actuator is activated)	12 V
					Other than UNLOCK (Actuator is not activated)	0 V
10 (BR)	Ground	Rear RH door and rear LH door UN- LOCK	Output	Rear RH door and rear LH door	UNLOCK (Actuator is activated)	12 V
					Other than UNLOCK (Actuator is not activated)	0 V
11 (R)	Ground	Battery power supply	Input	Ignition switch OFF		Battery voltage
13 (B)	Ground	Ground	—	Ignition switch ON		0 V
15 (Y)	Ground	ACC indicator lamp	Output	Ignition switch	OFF (LOCK indicator is not illuminated)	Battery voltage
					ACC or ON	0 V
17 (W)	Ground	Turn signal RH (Front)	Output	Ignition switch ON	Turn signal switch OFF	0 V
					Turn signal switch RH	 6.5 V

# BCM (BODY CONTROL MODULE)

## < ECU DIAGNOSIS INFORMATION >

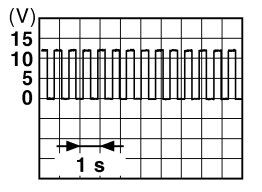
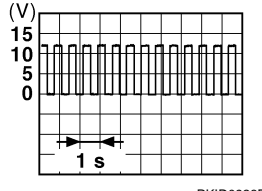
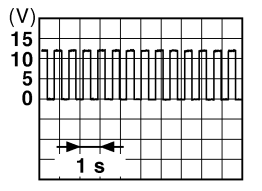
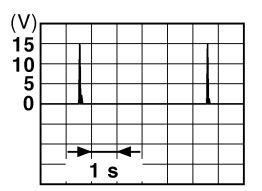
Terminal No. (Wire color)		Description		Condition	Value (Approx.)
+	-	Signal name	Input/ Output		
18 (BG)	Ground	Turn signal LH (Front)	Output	Ignition switch ON	Turn signal switch OFF 0 V
				Turn signal switch LH	 6.5 V
19 (SB)	Ground	Interior room lamp control	Output	Other than under condition	5.0 V
				<ul style="list-style-type: none"> <li>Interior room lamp timer is activated. (Door is unlocked. etc...)</li> <li>Welcome light function is activated.</li> </ul>	0 V
20 (V)	Ground	Turn signal RH (Rear)	Output	Ignition switch ON	Turn signal switch OFF 0 V
				Turn signal switch RH	 6.5 V
25 (G)	Ground	Turn signal LH (Rear)	Output	Ignition switch ON	Turn signal switch OFF 0 V
				Turn signal switch LH	 6.5 V
26 (P)	Ground	Rear wiper	Output	Rear wiper	OFF (Stopped) 0 V
				ON (Operated)	12 V
34 (SB)	Ground	Luggage room anten- na (-)	Output	Ignition switch OFF	When Intelligent Key is in the passenger compart- ment
				When Intelligent Key is not in the passenger com- partment	 12 V

A  
B  
C  
D  
E  
F  
G  
H  
I  
J  
K  
L  
N  
O  
P

BCS

# BCM (BODY CONTROL MODULE)

## < ECU DIAGNOSIS INFORMATION >

Terminal No. (Wire color)		Description		Condition	Value (Approx.)
+	-	Signal name	Input/ Output		
35 (V)	Ground	Luggage room antenna (+)	Output	Ignition switch OFF	
				When Intelligent Key is not in the passenger compartment	
38 (B)	Ground	Back door antenna (-)	Output	When the back door opener request switch is operated with ignition switch OFF	
				When Intelligent Key is not in the antenna detection area	
39 (W)	Ground	Back door antenna (+)	Output	When the back door opener request switch is operated with ignition switch OFF	
				When Intelligent Key is not in the antenna detection area	
47 (Y)	Ground	Ignition relay (IPDM E/R) control	Output	Ignition switch	12 V
				OFF or ACC	0 V

# BCM (BODY CONTROL MODULE)

## < ECU DIAGNOSIS INFORMATION >

Terminal No. (Wire color)		Description		Condition	Value (Approx.)
+	-	Signal name	Input/ Output		
52 (LG)	Ground	Starter relay control	Output	Ignition switch ON	12 V
				When selector lever is not in P or N position	0 V
60 (SB)	Ground	Push-button ignition switch (Push switch)	Input	Push-button ignition switch (Push switch)	0 V
				Pressed	12 V
61 (W)	Ground	Back door opener request switch	Input	Back door request switch	0 V
				ON (Pressed)	1.0 V
64 (L)	Ground	Intelligent Key warning buzzer (Engine room)	Output	Intelligent Key warning buzzer (Engine room)	0 V
				Not sounding	12 V
65 (BG)	Ground	Rear wiper stop position	Input	Rear wiper	0 V
				In stop position	1.0 V
66 (LG)	Ground	Back door switch	Input	Back door switch	0 V
				OFF (Door close)	12 V
67 (P)	Ground	Back door opener switch	Input	Back door opener switch	0 V
				Not pressed	8.5 - 9.0 V
68 (BR)	Ground	Rear RH door switch	Input	Rear RH door switch	0 V
				OFF (Door close)	8.5 - 9.0 V
				ON (Door open)	0 V

A  
B  
C  
D  
E  
F  
G  
H  
I  
J  
K  
L

BCS

N  
O  
P

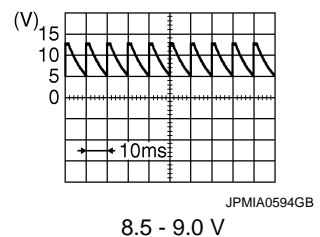
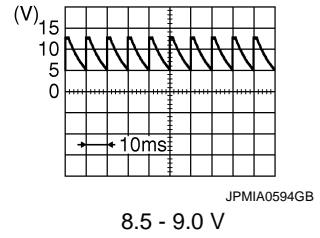
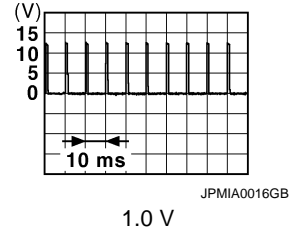
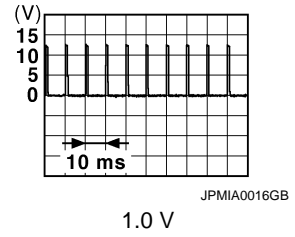

# BCM (BODY CONTROL MODULE)

## < ECU DIAGNOSIS INFORMATION >

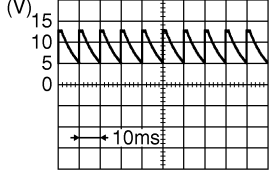
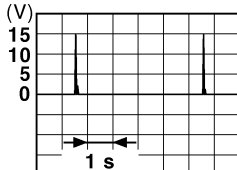
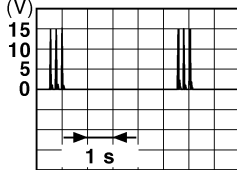
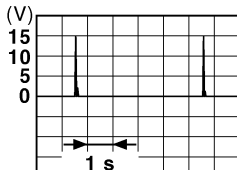
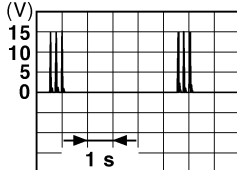
Terminal No. (Wire color)		Description		Condition	Value (Approx.)	
+	-	Signal name	Input/ Output			
69 (R)	Ground	Rear LH door switch	Input	Rear LH door switch	OFF (Door close)	 8.5 - 9.0 V
				ON (Door open)	0 V	
74 (SB)	Ground	Passenger door antenna (-)	Output	When the passenger door request switch is operated with ignition switch OFF	When Intelligent Key is in the antenna detection area	 JMKIA0062GB
				When Intelligent Key is not in the antenna detection area	 JMKIA0063GB	
75 (BR)	Ground	Passenger door antenna (+)	Output	When the passenger door request switch is operated with ignition switch OFF	When Intelligent Key is in the antenna detection area	 JMKIA0062GB
				When Intelligent Key is not in the antenna detection area	 JMKIA0063GB	



# BCM (BODY CONTROL MODULE)

## < ECU DIAGNOSIS INFORMATION >

Terminal No. (Wire color)		Description		Condition	Value (Approx.)
+	-	Signal name	Input/ Output		
76 (V)	Ground	Driver door antenna (-)	Output	When the driver door request switch is operated with ignition switch OFF	
				When Intelligent Key is in the antenna detection area	
77 (LG)	Ground	Driver door antenna (+)	Output	When the driver door request switch is operated with ignition switch OFF	
				When Intelligent Key is in the antenna detection area	
78 (Y)	Ground	Room antenna (-) (Instrument panel)	Output	Ignition switch OFF	
				When Intelligent Key is in the passenger compartment	

A

B

C

D

E

F

G

H

I

J

K

L

BCS

N

O

P

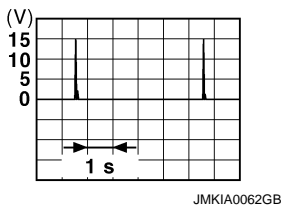
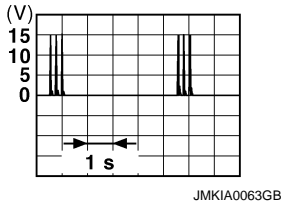
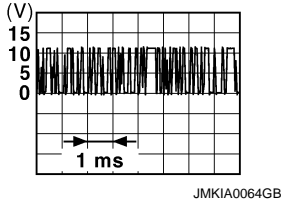
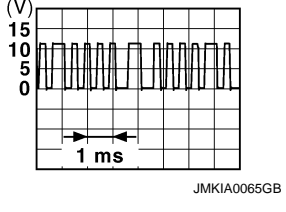

# BCM (BODY CONTROL MODULE)

## < ECU DIAGNOSIS INFORMATION >

Terminal No. (Wire color)		Description		Condition	Value (Approx.)	
+	-	Signal name	Input/ Output			
79 (BR)	Ground	Room antenna (+) (Instrument panel)	Output	Ignition switch OFF		
				When Intelligent Key is not in the passenger compart- ment		
80 (GR)	Ground	NATS antenna amp.	Input/ Output	During waiting	Ignition switch is pressed while inserting the Intelli- gent Key into the key slot.	Just after pressing ignition switch. Pointer of tester should move.
81 (W)	Ground	NATS antenna amp.	Input/ Output	During waiting	Ignition switch is pressed while inserting the Intelli- gent Key into the key slot.	Just after pressing ignition switch. Pointer of tester should move.
82 (P)	Ground	Ignition relay [Fuse block (J/B)] control	Output	Ignition switch	OFF or ACC	0 V
					ON	12 V
83 (GR)	Ground	Remote keyless entry receiver communica- tion	Input/ Output	During waiting		
				When operating either button on the Intelli- gent Key		

# BCM (BODY CONTROL MODULE)

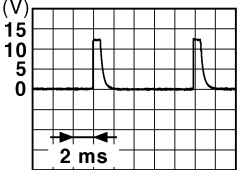
## < ECU DIAGNOSIS INFORMATION >

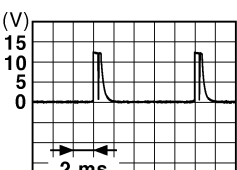
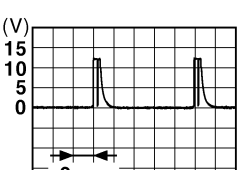
Terminal No. (Wire color)		Description		Condition	Value (Approx.)
+	-	Signal name	Input/ Output		
87 (BR)	Ground	Combination switch INPUT 5	Input	Combination switch	All switches OFF (Wiper volume dial 4) <div style="text-align: right;">  <p style="text-align: right;">1.4 V</p> </div>
					Front fog lamp switch ON (Wiper volume dial 4) <div style="text-align: right;">  <p style="text-align: right;">1.3 V</p> </div>
					Rear wiper switch ON (Wiper volume dial 4) <div style="text-align: right;">  <p style="text-align: right;">1.3 V</p> </div>
					Any of the conditions below with all switches OFF <ul style="list-style-type: none"> <li>• Wiper volume dial 1</li> <li>• Wiper volume dial 2</li> <li>• Wiper volume dial 6</li> <li>• Wiper volume dial 7</li> </ul> <div style="text-align: right;">  <p style="text-align: right;">1.3 V</p> </div>

A  
B  
C  
D  
E  
F  
G  
H  
I  
J  
K  
L

BCS

N  
O  
P

# BCM (BODY CONTROL MODULE)

## < ECU DIAGNOSIS INFORMATION >

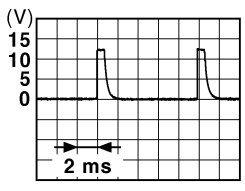
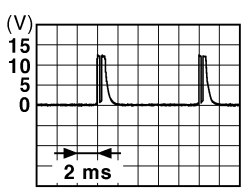
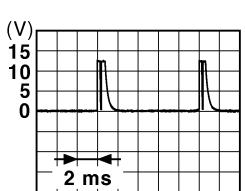
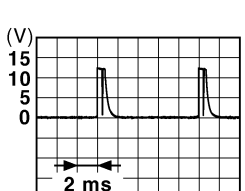
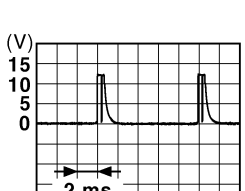
Terminal No. (Wire color)		Description		Condition	Value (Approx.)	
+	-	Signal name	Input/ Output			
88 (V)	Ground	Combination switch INPUT 3	Input	Combination switch	All switches OFF (Wiper volume dial 4)	 <p style="text-align: right; margin-right: 20px;">JPMIA0041GB</p> <p style="text-align: center;">1.4 V</p>
					Lighting switch HI (Wiper volume dial 4)	 <p style="text-align: right; margin-right: 20px;">JPMIA0036GB</p> <p style="text-align: center;">1.3 V</p>
					Lighting switch 2ND (Wiper volume dial 4)	 <p style="text-align: right; margin-right: 20px;">JPMIA0037GB</p> <p style="text-align: center;">1.3 V</p>
					Rear washer switch ON (Wiper volume dial 4)	 <p style="text-align: right; margin-right: 20px;">JPMIA0039GB</p> <p style="text-align: center;">1.3 V</p>
					Any of the conditions be- low with all switches OFF	<ul style="list-style-type: none"> <li>• Wiper volume dial 1</li> <li>• Wiper volume dial 2</li> <li>• Wiper volume dial 3</li> </ul>  <p style="text-align: right; margin-right: 20px;">JPMIA0040GB</p> <p style="text-align: center;">1.3 V</p>
90 (P)	Ground	CAN-L	Input/ Output	—	—	
91 (L)	Ground	CAN-H	Input/ Output	—	—	

# BCM (BODY CONTROL MODULE)

## < ECU DIAGNOSIS INFORMATION >

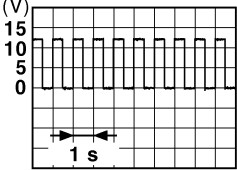
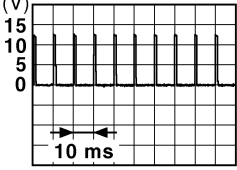
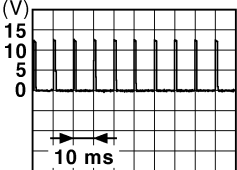
Terminal No. (Wire color)		Description		Condition	Value (Approx.)	
+	-	Signal name	Input/ Output			
92 (LG)	Ground	Key slot illumination	Output	Key slot illumination	OFF	12 V
					Blinking	 <p style="text-align: right; font-size: small;">JPMAI0015GB</p>
					ON	0 V
93 (V)	Ground	ON indicator lamp	Output	Ignition switch	OFF (LOCK indicator is not illuminated)	Battery voltage
					ON or ACC	0 V
95 (BG)	Ground	ACC relay control	Output	Ignition switch	OFF	0 V
					ACC or ON	12 V
96 (GR)	Ground	A/T shift selector (Detention switch) power supply	Output	—	12 V	
99 (R)	Ground	Selector lever P position switch	Input	Selector lever	P position	0 V
					Any position other than P	12 V
100 (G)	Ground	Passenger door request switch	Input	Passenger door request switch	ON (Pressed)	0 V
					OFF (Not pressed)	 <p style="text-align: right; font-size: small;">JPMAI0016GB</p>
101 (SB)	Ground	Driver door request switch	Input	Driver door request switch	ON (Pressed)	0 V
					OFF (Not pressed)	 <p style="text-align: right; font-size: small;">JPMAI0016GB</p>
102 (BG)	Ground	Blower fan motor relay control	Output	Ignition switch	OFF or ACC	0 V
					ON	12 V
103 (BR)	Ground	Remote keyless entry receiver power supply	Output	Ignition switch OFF	12 V	

A  
B  
C  
D  
E  
F  
G  
H  
I  
J  
K  
L  
N  
O  
P

BCS

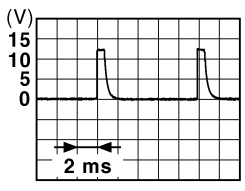
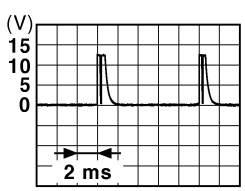
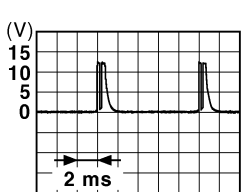
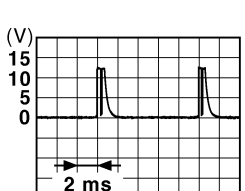
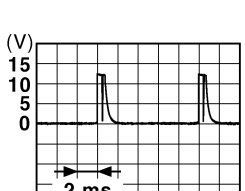

# BCM (BODY CONTROL MODULE)

## < ECU DIAGNOSIS INFORMATION >

Terminal No. (Wire color)		Description		Condition	Value (Approx.)
+	-	Signal name	Input/ Output		
107 (LG)	Ground	Combination switch INPUT 1	Input	Combination switch (Wiper volume dial 4)	All switches OFF <div style="text-align: right;">  <p style="text-align: right;">1.4 V</p> </div>
					Turn signal switch LH <div style="text-align: right;">  <p style="text-align: right;">1.3 V</p> </div>
					Turn signal switch RH <div style="text-align: right;">  <p style="text-align: right;">1.3 V</p> </div>
					Front wiper switch LO <div style="text-align: right;">  <p style="text-align: right;">1.3 V</p> </div>
					Front washer switch ON <div style="text-align: right;">  <p style="text-align: right;">1.3 V</p> </div>

# BCM (BODY CONTROL MODULE)

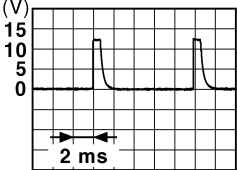
## < ECU DIAGNOSIS INFORMATION >

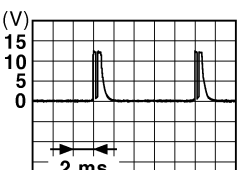
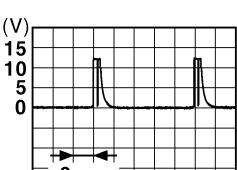
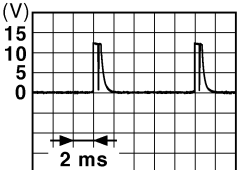

Terminal No. (Wire color)		Description		Condition	Value (Approx.)	
+	-	Signal name	Input/ Output			
108 (R)	Ground	Combination switch INPUT 4	Input	Combination switch	All switches OFF (Wiper volume dial 4)	 <p>1.4 V</p>
					Lighting switch AUTO (Wiper volume dial 4)	 <p>1.3 V</p>
					Lighting switch 1ST (Wiper volume dial 4)	 <p>1.3 V</p>
					Rear wiper switch INT (Wiper volume dial 4)	 <p>1.3 V</p>
					Any of the conditions below with all switches OFF <ul style="list-style-type: none"> <li>• Wiper volume dial 1</li> <li>• Wiper volume dial 5</li> <li>• Wiper volume dial 6</li> </ul>	 <p>1.3 V</p>

A  
B  
C  
D  
E  
F  
G  
H  
I  
J  
K  
L  
N  
O  
P

BCS

# BCM (BODY CONTROL MODULE)

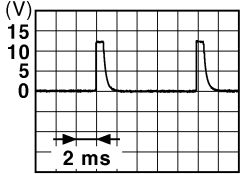
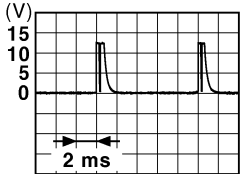
## < ECU DIAGNOSIS INFORMATION >

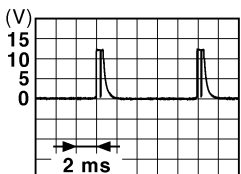
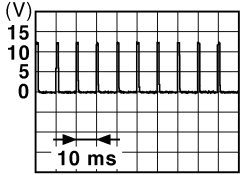
Terminal No. (Wire color)		Description		Condition	Value (Approx.)	
+	-	Signal name	Input/ Output			
109 (Y)	Ground	Combination switch INPUT 2	Input	Combination switch (Wiper volume dial 4)	All switches OFF	 <p style="text-align: right;">JPMIA0041GB 1.4 V</p>
					Lighting switch PASS	 <p style="text-align: right;">JPMIA0037GB 1.3 V</p>
					Lighting switch 2ND	 <p style="text-align: right;">JPMIA0036GB 1.3 V</p>
					Front wiper switch INT/ AUTO	 <p style="text-align: right;">JPMIA0038GB 1.3 V</p>
					Front wiper switch HI	 <p style="text-align: right;">JPMIA0040GB 1.3 V</p>
					ON	0 V
110 (G)	Ground	Hazard switch	Input	Hazard switch	OFF	 <p style="text-align: right;">JPMIA0012GB 1.1 V</p>



# BCM (BODY CONTROL MODULE)

## < ECU DIAGNOSIS INFORMATION >

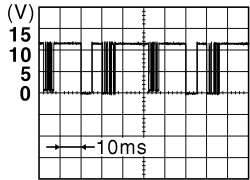
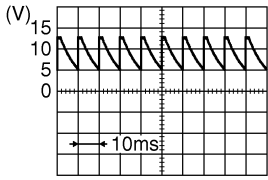
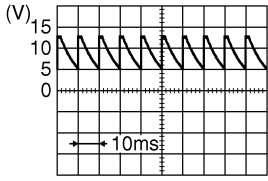
Terminal No. (Wire color)		Description		Condition	Value (Approx.)
+	-	Signal name	Input/ Output		
112 (GR)	Ground	Rain sensor serial link	Input/ Output	Ignition switch ON	 8.7 V
113 (P)	Ground	Optical sensor	Input	Ignition switch ON	When bright outside of the vehicle Close to 5 V
				When dark outside of the vehicle Close to 0 V	
116 (BR)	Ground	Stop lamp switch 1	Input	—	Battery voltage
118 (P)	Ground	Stop lamp switch 2 (Without ICC)	Input	Stop lamp switch OFF (Brake pedal is not depressed)	0 V
				Stop lamp switch ON (Brake pedal is depressed)	Battery voltage
		Stop lamp switch 2 (With ICC)		Stop lamp switch OFF (Brake pedal is not depressed) and ICC brake hold relay OFF	0 V
				Stop lamp switch ON (Brake pedal is depressed) or ICC brake hold relay ON	Battery voltage
119 (SB)	Ground	Front door lock assembly driver side (Unlock sensor)	Input	Driver door	 8.5 - 9.0 V
				UNLOCK status (Unlock switch sensor ON)	0 V
121 (BR)	Ground	Key slot switch	Input	When the Intelligent Key is inserted into key slot	12 V
				When the Intelligent Key is not inserted into key slot	0 V
123 (W)	Ground	IGN feedback	Input	Ignition switch OFF or ACC	0 V
				ON	Battery voltage
124 (LG)	Ground	Passenger door switch	Input	Passenger door switch	 8.5 - 9.0 V
				ON (Door open)	0 V

A  
B  
C  
D  
E  
F  
G  
H  
I  
J  
K  
L

BCS

N  
O  
P

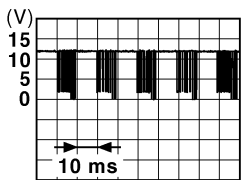
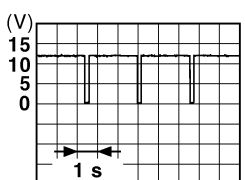
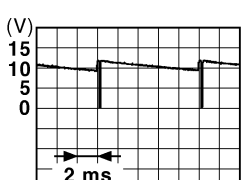
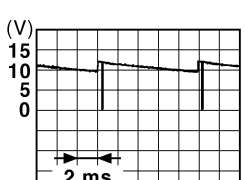

# BCM (BODY CONTROL MODULE)

## < ECU DIAGNOSIS INFORMATION >

Terminal No. (Wire color)		Description		Condition	Value (Approx.)
+	-	Signal name	Input/ Output		
132 (BG)	Ground	Power window switch communication	Input/ Output	Ignition switch ON	 <p style="text-align: right; font-size: small;">JPMIA0013GB</p> <p style="text-align: center;">10.2 V</p>
				Ignition switch OFF or ACC	12 V
134 (GR)	Ground	LOCK indicator lamp	Output	LOCK indicator lamp	Battery voltage
				OFF	0 V
137 (B)	Ground	Receiver and sensor ground	Input	Ignition switch ON	0 V
138 (Y)	Ground	Sensor power supply	Output	Ignition switch	0 V
				ACC or ON	5.0 V
140 (R)	Ground	Selector lever P/N position	Input	Selector lever	12 V
				Except P and N positions	0 V
141 (G)	Ground	Security indicator lamp	Output	Security indicator lamp	0 V
				Blinking	 <p style="text-align: right; font-size: small;">JPMIA0014GB</p> <p style="text-align: center;">11.3 V</p>
				OFF	12 V
142 (BG)	Ground	Combination switch OUTPUT 5	Output	Combination switch (Wiper volume dial 4)	0 V
				All switches OFF	0 V
				Lighting switch 1ST	 <p style="text-align: right; font-size: small;">JPMIA0031GB</p> <p style="text-align: center;">10.7 V</p>
				Lighting switch HI	
				Lighting switch 2ND	
Turn signal switch RH					
143 (P)	Ground	Combination switch OUTPUT 1	Output	Combination switch	0 V
				All switches OFF (Wiper volume dial 4)	 <p style="text-align: right; font-size: small;">JPMIA0032GB</p> <p style="text-align: center;">10.7 V</p>
				Front wiper switch HI (Wiper volume dial 4)	
				Rear wiper switch INT (Wiper volume dial 4)	
				Any of the conditions below with all switches OFF	
<ul style="list-style-type: none"> <li>• Wiper volume dial 1</li> <li>• Wiper volume dial 2</li> <li>• Wiper volume dial 3</li> <li>• Wiper volume dial 6</li> <li>• Wiper volume dial 7</li> </ul>					

# BCM (BODY CONTROL MODULE)

## < ECU DIAGNOSIS INFORMATION >

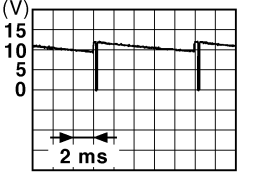
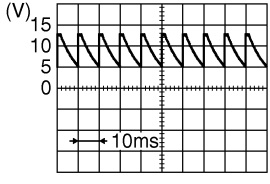
Terminal No. (Wire color)		Description		Condition	Value (Approx.)	
+	-	Signal name	Input/ Output			
144 (G)	Ground	Combination switch OUTPUT 2	Output	Combination switch	All switches OFF (Wiper volume dial 4)	0 V
					Front washer switch ON (Wiper volume dial 4)	
					Rear wiper switch ON (Wiper volume dial 4)	
					Rear washer switch ON (Wiper volume dial 4)	
					Any of the conditions below with all switches OFF <ul style="list-style-type: none"> <li>• Wiper volume dial 1</li> <li>• Wiper volume dial 5</li> <li>• Wiper volume dial 6</li> </ul>	
145 (L)	Ground	Combination switch OUTPUT 3	Output	Combination switch (Wiper volume dial 4)	All switches OFF	0 V
					Front wiper switch INT/ AUTO	
					Front wiper switch LO	
					Lighting switch AUTO	
146 (SB)	Ground	Combination switch OUTPUT 4	Output	Combination switch (Wiper volume dial 4)	All switches OFF	0 V
					Front fog lamp switch ON	
					Lighting switch 2ND	
					Lighting switch PASS	
					Turn signal switch LH	
150 (GR)	Ground	Driver door switch	Input	Driver door switch	OFF (Door close)	 8.5 - 9.0 V
					ON (Door open)	0 V
151 (G)	Ground	Rear window defog- ger relay control	Output	Rear window de- fogger	Active	0 V
					Not activated	Battery voltage

A  
B  
C  
D  
E  
F  
G  
H  
I  
J  
K  
L  
N  
O  
P

BCS

# BCM (BODY CONTROL MODULE)

< ECU DIAGNOSIS INFORMATION >

## Wiring Diagram - BCM -

INFOID:000000007514237

For connector terminal arrangements, harness layouts, and alphabets in a  (option abbreviation; if not described in wiring diagram), refer to [GI-13, "Connector Information"](#).

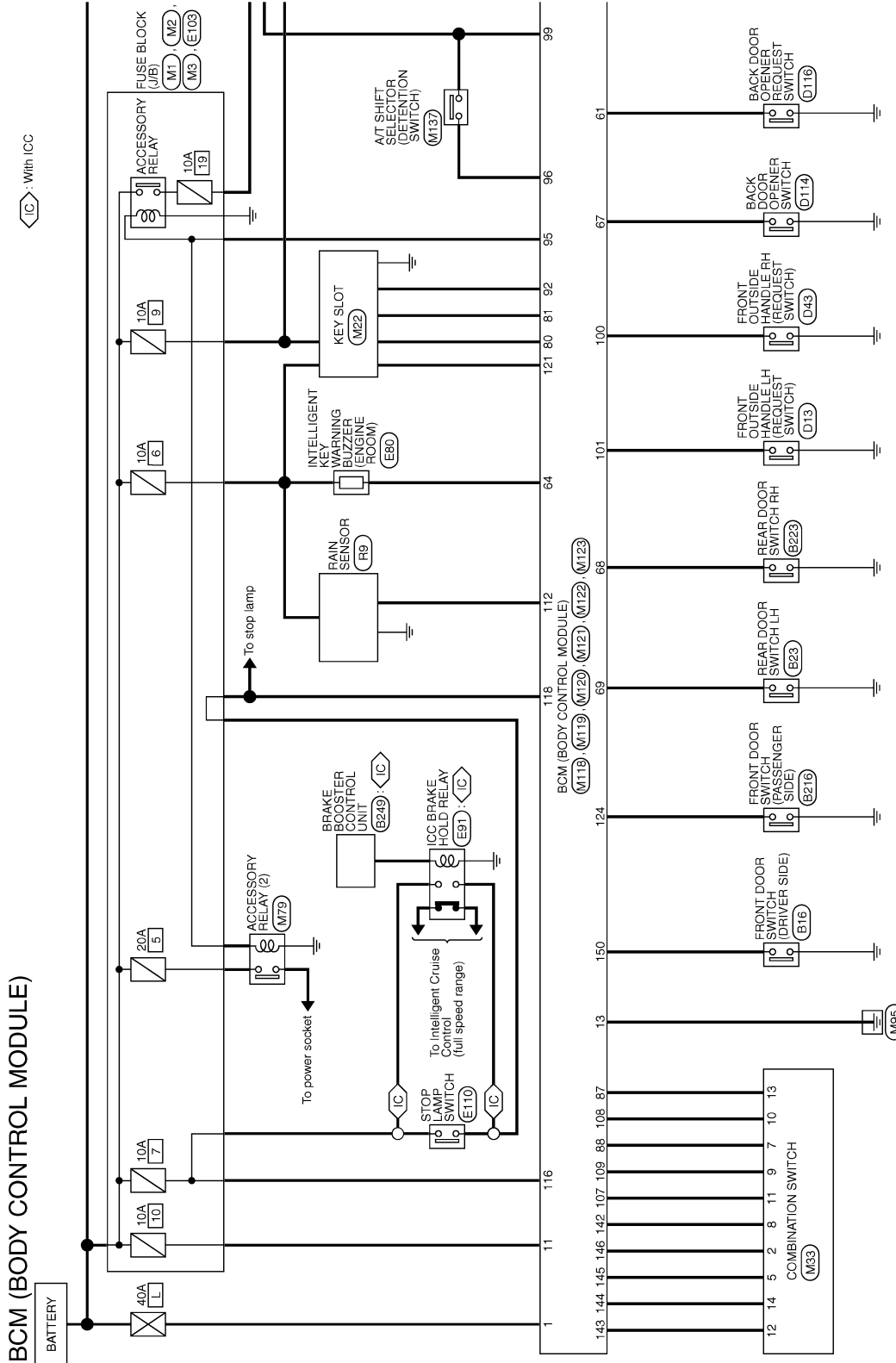

# BCM (BODY CONTROL MODULE)

< ECU DIAGNOSIS INFORMATION >

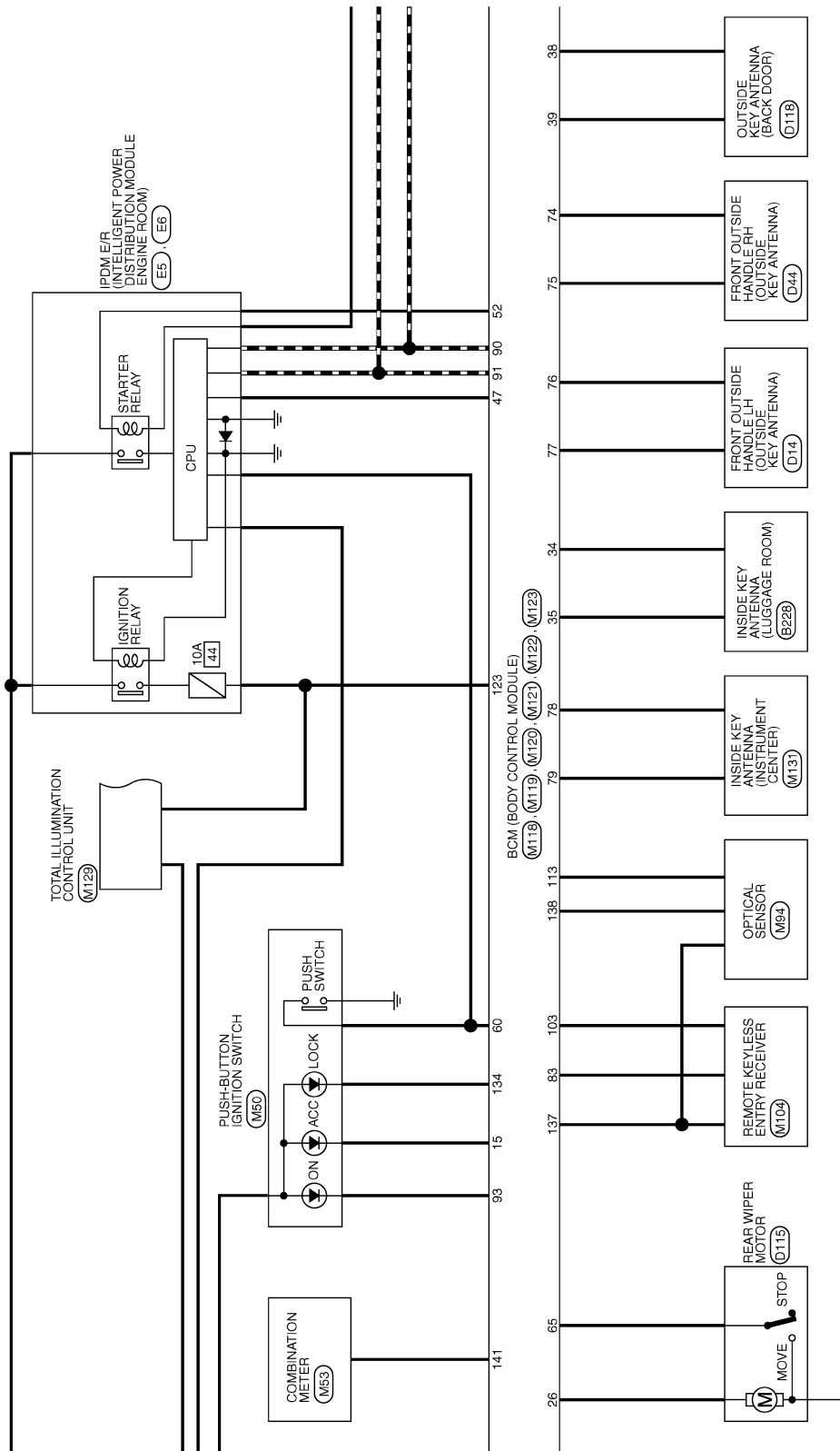

JRMWC4837GB

A  
B  
C  
D  
E  
F  
G  
H  
I  
J  
K  
L  
N  
O  
P

BCS

# BCM (BODY CONTROL MODULE)

< ECU DIAGNOSIS INFORMATION >

- ◊VC◊ : With VQ engine
- ◊VK◊ : With VK engine
- ◊NV◊ : With NAVI
- ◊CN◊ : Without NAVI
- ◊FM◊ : With automatic drive positioner
- ◊OP◊ : Without automatic drive positioner

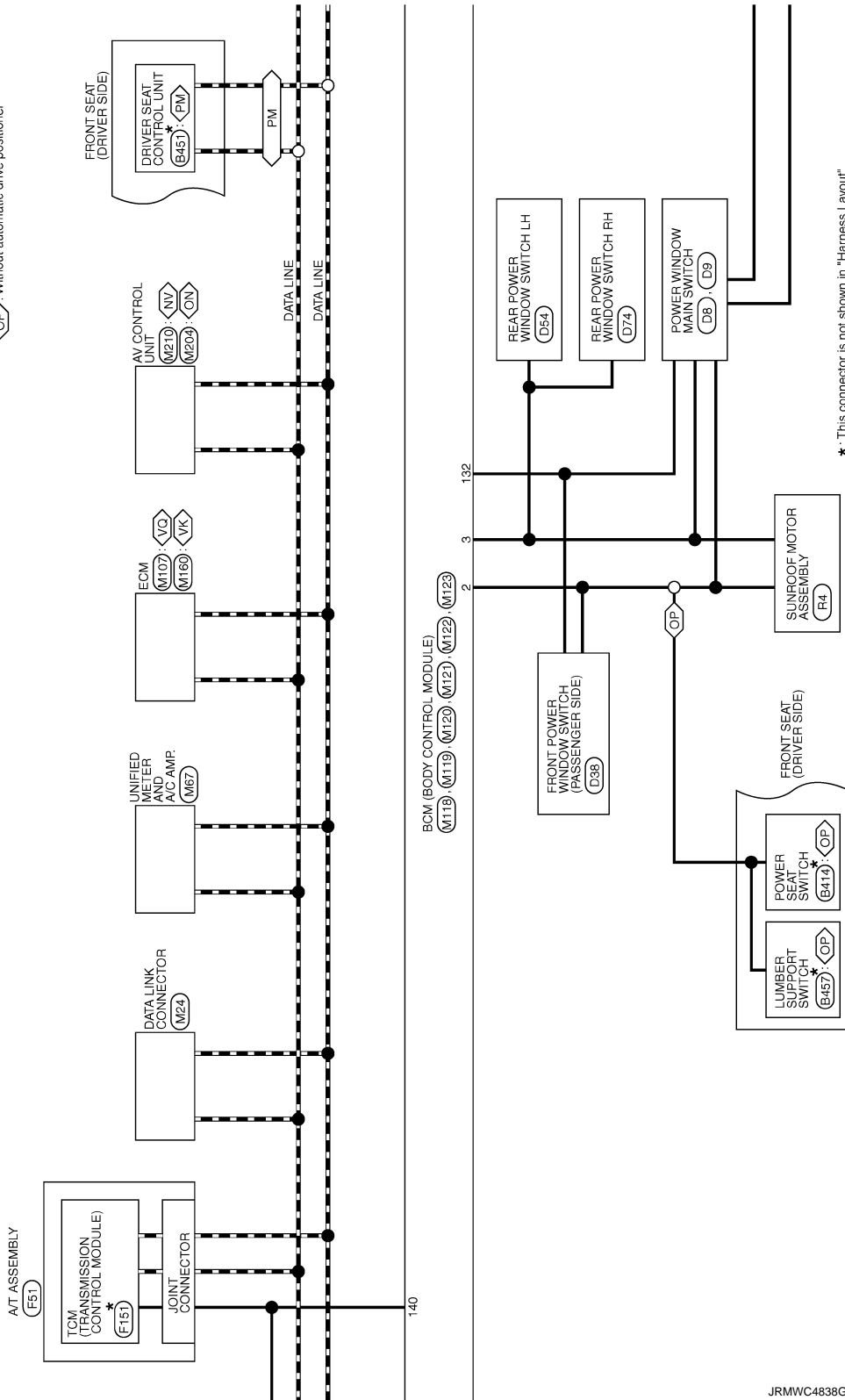

JRMWC4838GB

# BCM (BODY CONTROL MODULE)

< ECU DIAGNOSIS INFORMATION >

IC : With ICC  
OI : Without ICC

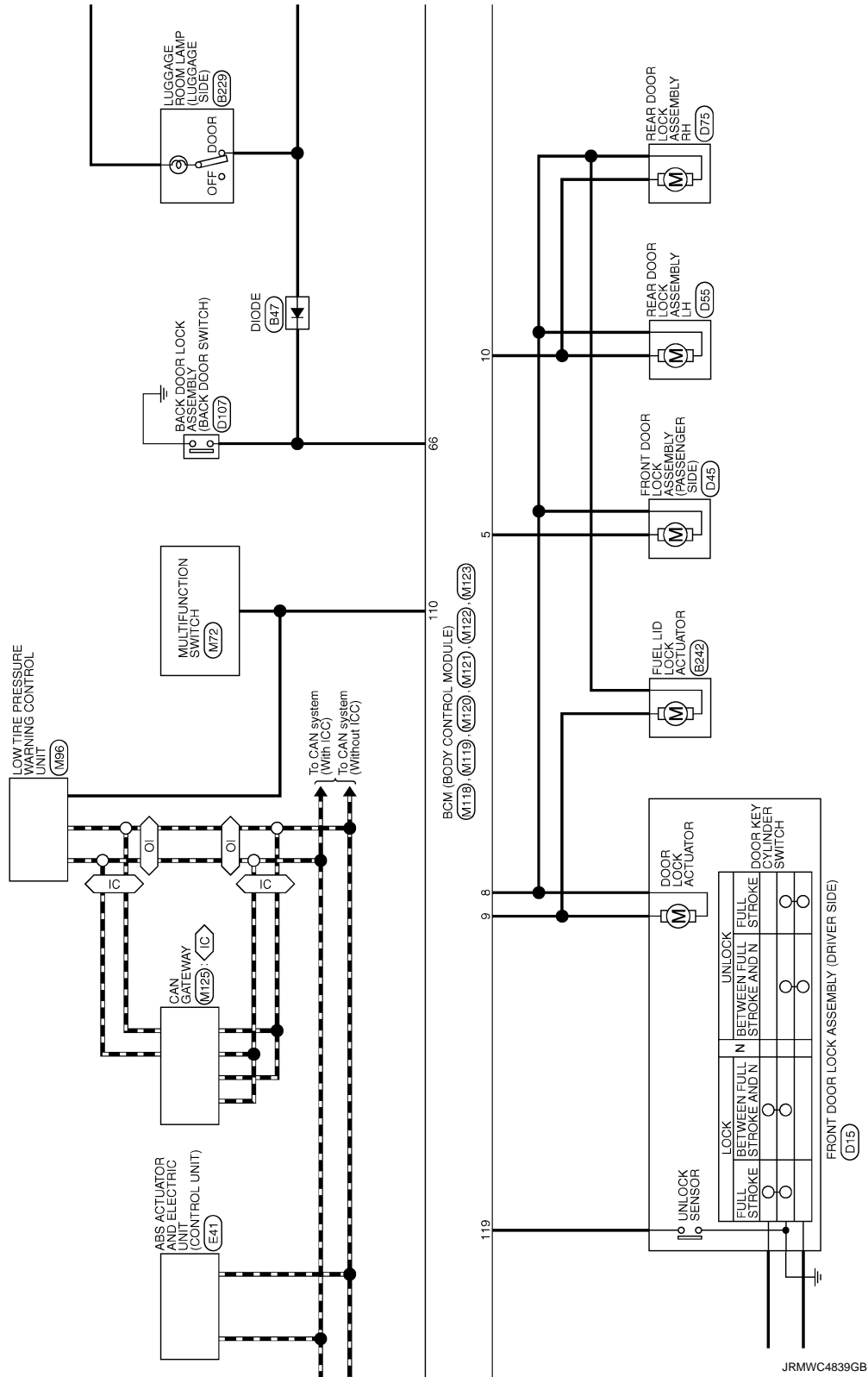

JRMWC4839GB

A  
B  
C  
D  
E  
F  
G  
H  
I  
J  
K  
L  
N  
O  
P

BCS

# BCM (BODY CONTROL MODULE)

< ECU DIAGNOSIS INFORMATION >

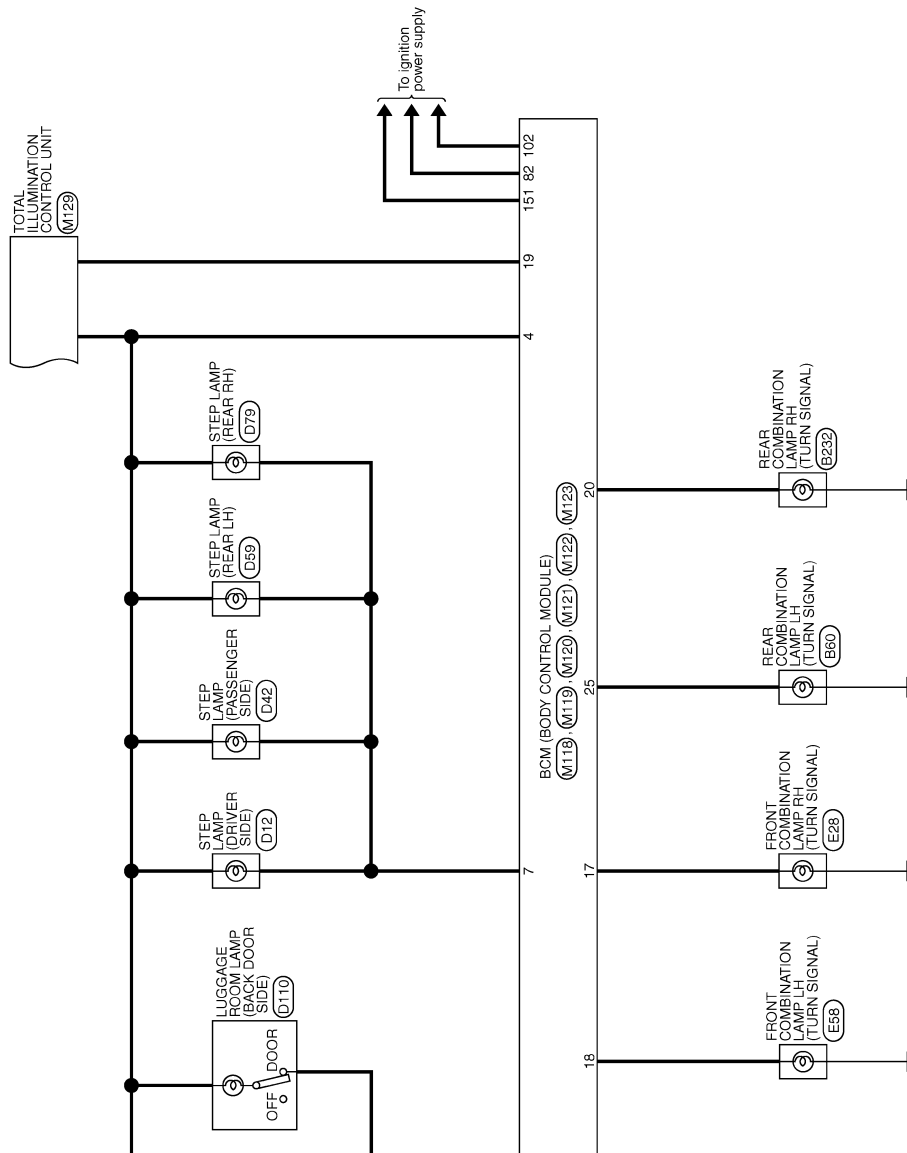

JRMWC4840GB

## Fail-safe

INFOID:000000007514238

### FAIL-SAFE CONTROL BY DTC

BCM performs fail-safe control when any DTC are detected.



# BCM (BODY CONTROL MODULE)

## < ECU DIAGNOSIS INFORMATION >

Display contents of CONSULT	Fail-safe	Cancellation
B2190: NATS ANTENNA AMP	Inhibit engine cranking	Erase DTC
B2191: DIFFERENCE OF KEY	Inhibit engine cranking	Erase DTC
B2192: ID DISCORD BCM-ECM	Inhibit engine cranking	Erase DTC
B2193: CHAIN OF BCM-ECM	Inhibit engine cranking	Erase DTC
B2195: ANTI SCANNING	Inhibit engine cranking	Ignition switch ON → OFF
B2560: STARTER CONT RELAY	Inhibit engine cranking	500 ms after the following CAN signal communication status becomes consistent <ul style="list-style-type: none"> <li>• Starter control relay signal</li> <li>• Starter relay status signal</li> </ul>
B2608: STARTER RELAY	Inhibit engine cranking	500 ms after the following signal communication status becomes consistent <ul style="list-style-type: none"> <li>• Starter relay control signal</li> <li>• Starter relay status signal (CAN)</li> </ul>
B260A: IGNITION RELAY	Inhibit engine cranking	500 ms after the following conditions are fulfilled <ul style="list-style-type: none"> <li>• IGN relay (IPDM E/R) control signal: OFF (Battery voltage)</li> <li>• Ignition ON signal (CAN to IPDM E/R): OFF (Request signal)</li> <li>• Ignition ON signal (CAN from IPDM E/R): OFF (Condition signal)</li> </ul>
B260F: ENG STATE SIG LOST	Maintains the power supply position attained at the time of DTC detection	When any of the following conditions are fulfilled <ul style="list-style-type: none"> <li>• Power position changes to ACC</li> <li>• Receives engine status signal (CAN)</li> </ul>
B2617: STARTER RELAY CIRC	Inhibit engine cranking	1 second after the starter relay control inside BCM becomes normal
B2618: BCM	Inhibit engine cranking	1 second after the ignition relay (IPDM E/R) control inside BCM becomes normal
B261E: VEHICLE TYPE	Inhibit engine cranking	BCM initialization

### FAIL-SAFE CONTROL BY RAIN SENSOR MALFUNCTION

- BCM judges the rain sensor serial link error by the rain sensor serial link condition and detects the rain sensor malfunction by rain sensor malfunction signal.
- When BCM detects the rain sensor serial link error or the rain sensor malfunction while front wiper AUTO operation, BCM operates a fail-safe control.

#### NOTE:

If rain sensor malfunction is detected when ignition switch is turned OFF ⇒ ON and front wiper switch is INT position, BCM operates a fail-safe control.

### REAR WIPER MOTOR PROTECTION

BCM detects the rear wiper stopping position according to the rear wiper stop position signal. When the rear wiper stop position signal does not change for more than 5 seconds while driving the rear wiper, BCM stops power supply to protect the rear wiper motor.

#### Condition of cancellation

1. More than 1 minute is passed after the rear wiper stops.
2. Turn rear wiper switch OFF.
3. Operate the rear wiper switch or rear washer switch.

### DTC Inspection Priority Chart

INFOID:000000007514239

If some DTCs are displayed at the same time, perform inspections one by one based on the following priority chart.

Priority	DTC
1	B2562: LOW VOLTAGE
2	<ul style="list-style-type: none"> <li>• U1000: CAN COMM</li> <li>• U1010: CONTROL UNIT(CAN)</li> </ul>

# BCM (BODY CONTROL MODULE)

## < ECU DIAGNOSIS INFORMATION >

Priority	DTC
3	<ul style="list-style-type: none"> <li>• B2190: NATS ANTENNA AMP</li> <li>• B2191: DIFFERENCE OF KEY</li> <li>• B2192: ID DISCORD BCM-ECM</li> <li>• B2193: CHAIN OF BCM-ECM</li> <li>• B2195: ANTI SCANNING</li> </ul>
4	<ul style="list-style-type: none"> <li>• B2553: IGNITION RELAY</li> <li>• B2555: STOP LAMP</li> <li>• B2556: PUSH-BTN IGN SW</li> <li>• B2557: VEHICLE SPEED</li> <li>• B2560: STARTER CONT RELAY</li> <li>• B2601: SHIFT POSITION</li> <li>• B2602: SHIFT POSITION</li> <li>• B2603: SHIFT POSI STATUS</li> <li>• B2604: PNP/CLUTCH SW</li> <li>• B2605: PNP/CLUTCH SW</li> <li>• B2608: STARTER RELAY</li> <li>• B260A: IGNITION RELAY</li> <li>• B260F: ENG STATE SIG LOST</li> <li>• B2614: BCM</li> <li>• B2615: BCM</li> <li>• B2616: BCM</li> <li>• B2617: BCM</li> <li>• B2618: BCM</li> <li>• B261A: PUSH-BTN IGN SW</li> <li>• B261E: VEHICLE TYPE</li> <li>• B26EA: KEY REGISTRATION</li> <li>• U0415: VEHICLE SPEED SIG</li> </ul>
5	<ul style="list-style-type: none"> <li>• B2621: INSIDE ANTENNA</li> <li>• B2623: INSIDE ANTENNA</li> </ul>
6	B26E7: TPMS CAN COMM

## DTC Index

INFOID:000000007514240

### NOTE:

The details of time display are as follows.

- CRNT: A malfunction is detected now.
- PAST: A malfunction was detected in the past.

IGN counter is displayed on Freeze Frame Data. For details of Freeze Frame Data, refer to [BCS-18, "COMMON ITEM : CONSULT Function \(BCM - COMMON ITEM\)"](#).

CONSULT display	Fail-safe	Freeze Frame Data •Vehicle Speed •Odo/Trip Meter •Vehicle Condition	Intelligent Key warn- ing lamp ON	Reference
No DTC is detected. Further testing may be required.	—	—	—	—
U1000: CAN COMM	—	—	—	<a href="#">BCS-36</a>
U1010: CONTROL UNIT(CAN)	—	—	—	<a href="#">BCS-37</a>
U0415: VEHICLE SPEED SIG	—	—	—	<a href="#">BCS-38</a>
B2190: NATS ANTENNA AMP	×	—	—	<a href="#">SEC-47</a>
B2191: DIFFERENCE OF KEY	×	—	—	<a href="#">SEC-50</a>
B2192: ID DISCORD BCM-ECM	×	—	—	<a href="#">SEC-51</a>
B2193: CHAIN OF BCM-ECM	×	—	—	<a href="#">SEC-53</a>
B2195: ANTI SCANNING	×	—	—	<a href="#">SEC-54</a>
B2553: IGNITION RELAY	—	×	—	<a href="#">PCS-49</a>
B2555: STOP LAMP	—	×	—	<a href="#">SEC-55</a>

## BCM (BODY CONTROL MODULE)

< ECU DIAGNOSIS INFORMATION >

CONSULT display	Fail-safe	Freeze Frame Data •Vehicle Speed •Odo/Trip Meter •Vehicle Condition	Intelligent Key warn- ing lamp ON	Reference	A
B2556: PUSH-BTN IGN SW	—	×	×	<a href="#">SEC-57</a>	B
B2557: VEHICLE SPEED	×	×	×	<a href="#">SEC-59</a>	C
B2560: STARTER CONT RELAY	×	×	×	<a href="#">SEC-60</a>	D
B2562: LOW VOLTAGE	—	×	—	<a href="#">BCS-39</a>	E
B2601: SHIFT POSITION	×	×	×	<a href="#">SEC-61</a>	F
B2602: SHIFT POSITION	×	×	×	<a href="#">SEC-64</a>	G
B2603: SHIFT POSI STATUS	×	×	×	<a href="#">SEC-66</a>	H
B2604: PNP/CLUTCH SW	×	×	×	<a href="#">SEC-69</a>	I
B2605: PNP/CLUTCH SW	×	×	×	<a href="#">SEC-71</a>	J
B2608: STARTER RELAY	×	×	×	<a href="#">SEC-73</a>	K
B260A: IGNITION RELAY	×	×	×	<a href="#">PCS-51</a>	L
B260F: ENG STATE SIG LOST	×	×	×	<a href="#">SEC-75</a>	A
B2614: BCM	—	×	×	<a href="#">PCS-53</a>	B
B2615: BCM	—	×	×	<a href="#">PCS-55</a>	C
B2616: BCM	—	×	×	<a href="#">PCS-57</a>	D
B2617: BCM	×	×	×	<a href="#">SEC-77</a>	E
B2618: BCM	×	×	×	<a href="#">PCS-59</a>	F
B261A: PUSH-BTN IGN SW	—	×	×	<a href="#">SEC-79</a>	G
B261E: VEHICLE TYPE	×	×	× (Turn ON for 15 seconds)	<a href="#">SEC-82</a>	H
B2621: INSIDE ANTENNA	—	×	—	<a href="#">DLK-100</a>	I
B2623: INSIDE ANTENNA	—	×	—	<a href="#">DLK-102</a>	J
B26E7: TPMS CAN COMM	—	—	—	<a href="#">BCS-40</a>	K
B26EA: KEY REGISTRATION	—	×	× (Turn ON for 15 seconds)	<a href="#">SEC-76</a>	L

BCS

# COMBINATION SWITCH SYSTEM SYMPTOMS

< SYMPTOM DIAGNOSIS >

## SYMPTOM DIAGNOSIS

### COMBINATION SWITCH SYSTEM SYMPTOMS

#### Symptom Table

INFOID:000000007514241

1. Perform "Data Monitor" of CONSULT to check for any malfunctioning item.
2. Check the malfunction combinations.

Malfunction item: x

Malfunction combination	Data monitor item																
	FR WIPER HI	FR WIPER LOW	FR WASHER SW	FR WIPER INT	RR WIPER ON	RR WIPER INT	RR WASHER SW	INT VOLUME	TURN SIGNAL R	TURN SIGNAL L	TAIL LAMP SW	HI BEAM SW	HEAD LAMP SW 1	HEAD LAMP SW 2	PASSING SW	AUTO LIGHT SW	FR FOG SW
A		x	x						x	x							
B	x			x									x		x		
C							x	x				x		x			
D						x		x			x					x	
E					x			x									x
F	x					x		x									
G			x		x		x	x									
H		x		x												x	
I										x				x	x		x
J									x		x	x	x				
K	All Items																
L	If only one item is detected or the item is not applicable to the combinations A to K																

3. Identify the malfunctioning part from the agreed combination and repair or replace the part.

Malfunction combination	Malfunctioning part	Repair or replace
A	Combination switch INPUT 1 circuit	Inspect the combination switch input circuit applicable to the malfunctioning part. Refer to <a href="#">BCS-42, "Diagnosis Procedure"</a> .
B	Combination switch INPUT 2 circuit	
C	Combination switch INPUT 3 circuit	
D	Combination switch INPUT 4 circuit	
E	Combination switch INPUT 5 circuit	
F	Combination switch OUTPUT 1 circuit	Inspect the combination switch output circuit applicable to the malfunctioning part. Refer to <a href="#">BCS-44, "Diagnosis Procedure"</a> .
G	Combination switch OUTPUT 2 circuit	
H	Combination switch OUTPUT 3 circuit	
I	Combination switch OUTPUT 4 circuit	
J	Combination switch OUTPUT 5 circuit	
K	BCM	Replace BCM. Refer to <a href="#">BCS-79, "Exploded View"</a> .
L	Combination switch	Replace the combination switch.

# NORMAL OPERATING CONDITION

< SYMPTOM DIAGNOSIS >

## NORMAL OPERATING CONDITION

### Description

INFOID:000000007805097

#### TRANSIT MODE

- Transit mode inhibits battery power consumption during transportation or storage of the vehicle.
- BCM is set to transit mode before delivery.
- In transit mode, remote keyless entry function, headlamp ON/OFF function, theft warning alarm function, and other BCM control functions do not operate normally.
- Therefore, cancel operation must be performed so that the vehicle is used in normal status.
- For transit mode cancel operation, refer to [BCS-6. "Description"](#).

#### NOTE:

Do not cancel transit mode during storage of the vehicle. Always cancel transit mode before delivery of the vehicle to customer.

A  
B  
C  
D  
E  
F  
G  
H  
I  
J  
K  
L  
N  
O  
P

BCS

# PRECAUTIONS

< PRECAUTION >

## PRECAUTION

### PRECAUTIONS

#### Precaution for Supplemental Restraint System (SRS) "AIR BAG" and "SEAT BELT PRE-TENSIONER"

INFOID:000000007514242

The Supplemental Restraint System such as "AIR BAG" and "SEAT BELT PRE-TENSIONER", used along with a front seat belt, helps to reduce the risk or severity of injury to the driver and front passenger for certain types of collision. This system includes seat belt switch inputs and dual stage front air bag modules. The SRS system uses the seat belt switches to determine the front air bag deployment, and may only deploy one front air bag, depending on the severity of a collision and whether the front occupants are belted or unbelted. Information necessary to service the system safely is included in the "SRS AIR BAG" and "SEAT BELT" of this Service Manual.

#### **WARNING:**

Always observe the following items for preventing accidental activation.

- To avoid rendering the SRS inoperative, which could increase the risk of personal injury or death in the event of a collision that would result in air bag inflation, all maintenance must be performed by an authorized NISSAN/INFINITI dealer.
- Improper maintenance, including incorrect removal and installation of the SRS, can lead to personal injury caused by unintentional activation of the system. For removal of Spiral Cable and Air Bag Module, see "SRS AIR BAG".
- Never use electrical test equipment on any circuit related to the SRS unless instructed to in this Service Manual. SRS wiring harnesses can be identified by yellow and/or orange harnesses or harness connectors.

#### PRECAUTIONS WHEN USING POWER TOOLS (AIR OR ELECTRIC) AND HAMMERS

#### **WARNING:**

Always observe the following items for preventing accidental activation.

- When working near the Air Bag Diagnosis Sensor Unit or other Air Bag System sensors with the ignition ON or engine running, never use air or electric power tools or strike near the sensor(s) with a hammer. Heavy vibration could activate the sensor(s) and deploy the air bag(s), possibly causing serious injury.
- When using air or electric power tools or hammers, always switch the ignition OFF, disconnect the battery, and wait at least 3 minutes before performing any service.

# BCM (BODY CONTROL MODULE)

< REMOVAL AND INSTALLATION >

## REMOVAL AND INSTALLATION

### BCM (BODY CONTROL MODULE)

Exploded View

INFOID:000000007514243

#### NOTE:

Before replacing BCM, perform "READ CONFIGURATION" to save or print current vehicle specification. Refer to [BCS-3. "ADDITIONAL SERVICE WHEN REPLACING CONTROL UNIT \(BCM\) : Description"](#).

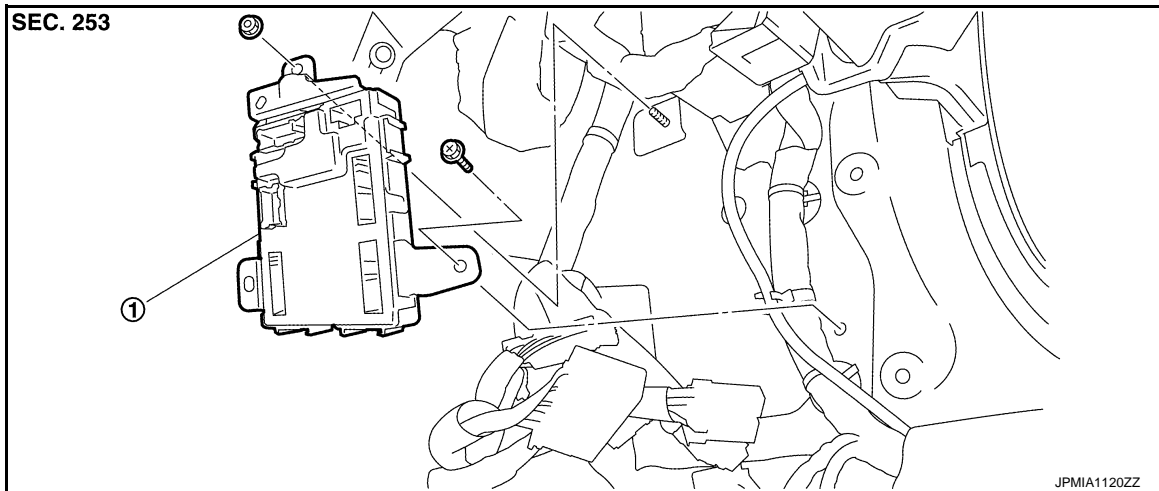

1. BCM

### Removal and Installation

INFOID:000000007514244

#### NOTE:

Before replacing BCM, perform "READ CONFIGURATION" to save or print current vehicle specification. Refer to [BCS-3. "ADDITIONAL SERVICE WHEN REPLACING CONTROL UNIT \(BCM\) : Description"](#).

#### REMOVAL

1. Remove dash side finisher (passenger side). Refer to [INT-17. "Exploded View"](#).
2. Remove bolt and nut.
3. Remove BCM and disconnect the connector.

#### INSTALLATION

Install in the reverse order of removal.

#### CAUTION:

**Be sure to perform "WRITE CONFIGURATION" when replacing BCM. Or not doing so, BCM control function does not operate normally.**

#### NOTE:

Be sure to perform the system initialization (NATS) when replacing BCM. Refer to [BCS-3. "ADDITIONAL SERVICE WHEN REPLACING CONTROL UNIT \(BCM\) : Work Procedure"](#).

A  
B  
C  
D  
E  
F  
G  
H  
I  
J  
K  
L  
N  
O  
P

BCS

# COMBINATION SWITCH

< REMOVAL AND INSTALLATION >

## COMBINATION SWITCH

### Exploded View

INFOID:000000007514245

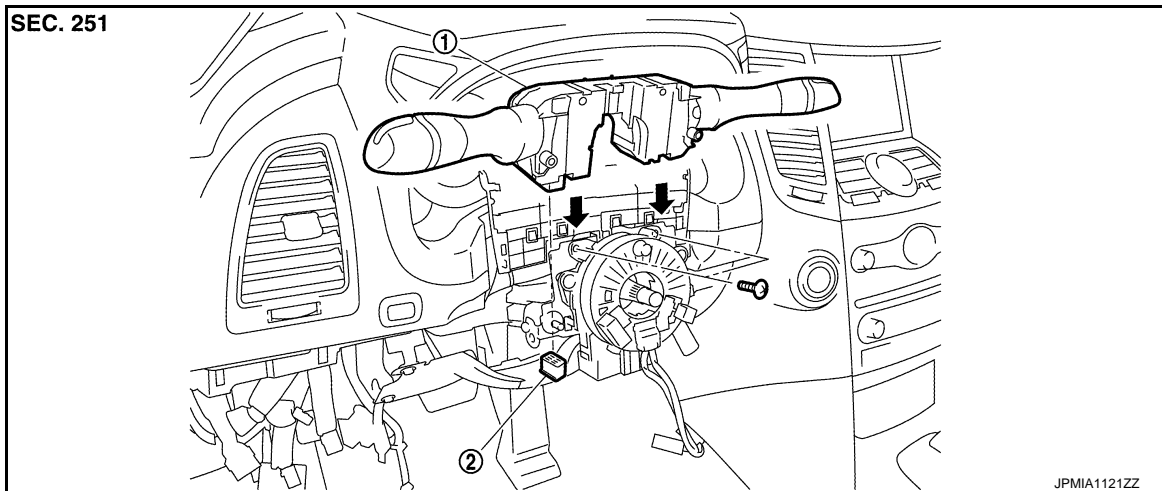

1. Combination switch

2. Combination switch connector

### Removal and Installation

INFOID:000000007514246

#### REMOVAL

1. Remove steering column cover. Refer to [IP-11, "Exploded View"](#).
2. Remove screws.
3. Disconnect the connector.
4. Pull up the combination switch to remove it.

#### INSTALLATION

Install in the reverse order of removal.