

A
CO
C
D
E
F
G
H
I
J
K
L
M
N
O
P

SECTION CO

ENGINE COOLING SYSTEM

CONTENTS

VQ35HR	
SYSTEM DESCRIPTION	3
DESCRIPTION	3
Engine Cooling System	3
Engine Cooling System Schematic	3
SYMPTOM DIAGNOSIS	4
OVERHEATING CAUSE ANALYSIS	4
Troubleshooting Chart	4
PRECAUTION	6
PRECAUTIONS	6
Precaution for Supplemental Restraint System (SRS) "AIR BAG" and "SEAT BELT PRE-TENSIONER"	6
PREPARATION	7
PREPARATION	7
Commercial Service Tools	7
PERIODIC MAINTENANCE	8
ENGINE COOLANT	8
Inspection	8
Draining	8
Refilling	9
Flushing	11
RADIATOR	12
RADIATOR CAP	12
RADIATOR CAP : Inspection	12
RADIATOR	12
RADIATOR : Inspection	12
REMOVAL AND INSTALLATION	14
RADIATOR	14
	Exploded View
	Removal and Installation
	Inspection
	14
	14
	17
COOLING FAN	18
Exploded View	18
Removal and Installation	18
Disassembly and Assembly	18
Inspection	19
WATER PUMP	20
Exploded View	20
Removal and Installation	20
Inspection	22
WATER INLET AND THERMOSTAT ASSEMBLY	23
Exploded View	23
Removal and Installation	23
Inspection	24
WATER OUTLET AND WATER PIPING	25
Exploded View	25
Removal and Installation	25
Inspection	26
SERVICE DATA AND SPECIFICATIONS (SDS)	27
SERVICE DATA AND SPECIFICATIONS (SDS)	27
Periodical Maintenance Specification	27
Radiator	27
Thermostat	27
VK50VE	
SYSTEM DESCRIPTION	28
DESCRIPTION	28
Engine Cooling System	28
Engine Cooling System Schematic	29

SYMPTOM DIAGNOSIS	30	REMOVAL AND INSTALLATION	40
OVERHEATING CAUSE ANALYSIS	30	RADIATOR	40
Troubleshooting Chart	30	Exploded View	40
PRECAUTION	32	Removal and Installation	40
PRECAUTIONS	32	Inspection	43
Precaution for Supplemental Restraint System (SRS) "AIR BAG" and "SEAT BELT PRE-TEN- SIONER"	32	COOLING FAN	44
PREPARATION	33	Exploded View	44
PREPARATION	33	Removal and Installation	44
Commercial Service Tools	33	Disassembly and Assembly	44
PERIODIC MAINTENANCE	34	Inspection	45
ENGINE COOLANT	34	WATER PUMP	46
Inspection	34	Exploded View	46
Draining	34	Removal and Installation	46
Refilling	35	Inspection	47
Flushing	37	WATER INLET AND THERMOSTAT ASSEM- BLY	48
RADIATOR	38	Exploded View	48
RADIATOR CAP	38	Removal and Installation	48
RADIATOR CAP : Inspection	38	Inspection	49
RADIATOR	38	SERVICE DATA AND SPECIFICATIONS (SDS)	51
RADIATOR : Inspection	38	SERVICE DATA AND SPECIFICATIONS (SDS)	51
		Periodical Maintenance Specification	51
		Radiator	51
		Thermostat	51

DESCRIPTION

< SYSTEM DESCRIPTION >

[VQ35HR]

SYSTEM DESCRIPTION

DESCRIPTION

Engine Cooling System

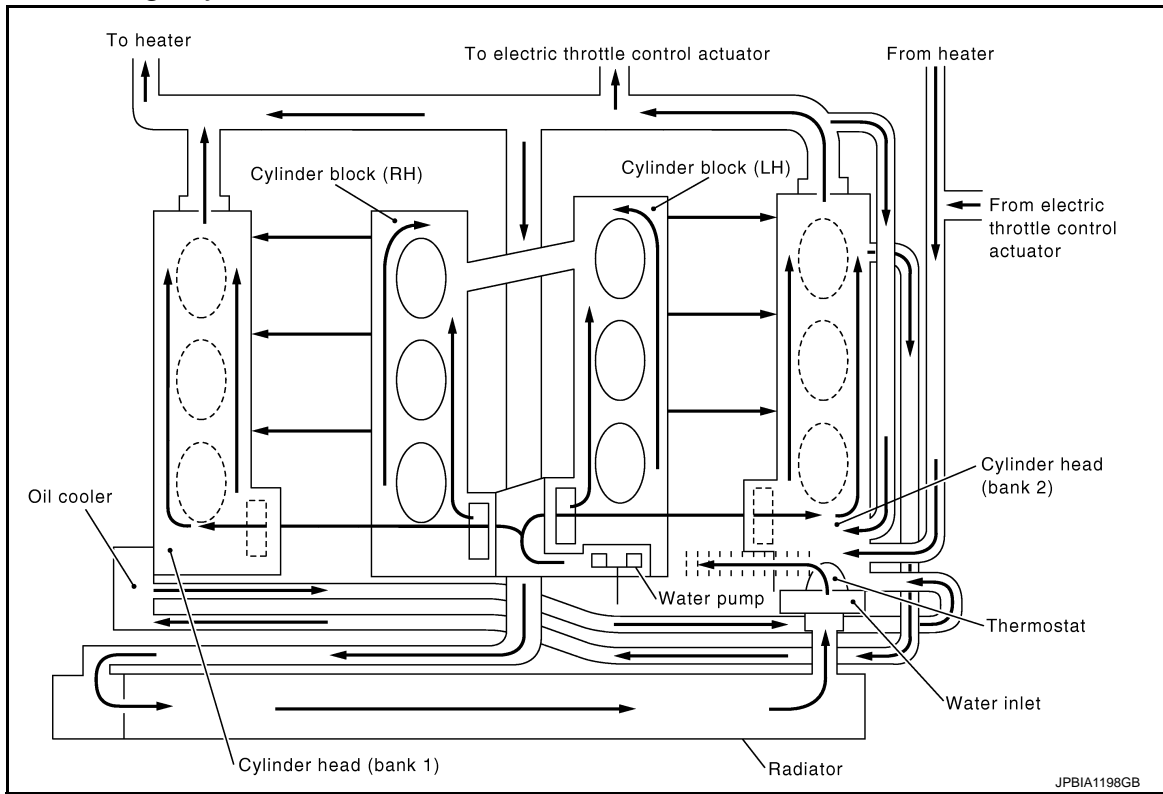

INFOID:000000007512272

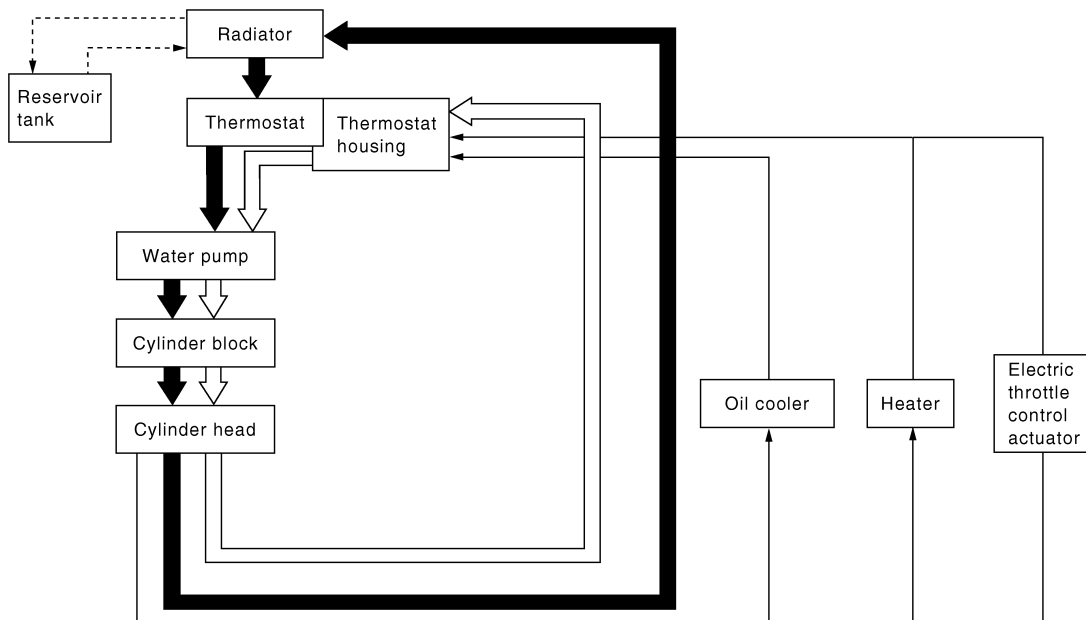

Engine Cooling System Schematic

INFOID:000000007512273

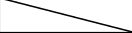
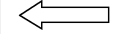

	Thermostat
	Closed
	Open

JP8IA1198GB

A
CO
C
D
E
F
G
H
I
J
K
L
M
N
O
P

OVERHEATING CAUSE ANALYSIS

< SYMPTOM DIAGNOSIS >

[VQ35HR]

SYMPTOM DIAGNOSIS

OVERHEATING CAUSE ANALYSIS

Troubleshooting Chart

INFOID:000000007512274

		Symptom	Check items	
Cooling system parts malfunction	Poor heat transfer	Water pump malfunction	Worn or loose drive belt	—
		Thermostat stuck closed	—	
		Damaged fins	Dust contamination or paper clogging	
			Physical damage	
	Clogged radiator cooling tube	Excess foreign material (rust, dirt, sand, etc.)		
	Reduced air flow	Cooling fan does not operate	Fan assembly	—
		High resistance to fan rotation		
		Damaged fan blades		
	Damaged radiator shroud	—	—	—
	Improper engine coolant mixture ratio	—	—	—
	Poor engine coolant quality	—	Engine coolant density	—
	Insufficient engine coolant	Engine coolant leakage	Cooling hose	Loose clamp
				Cracked hose
			Water pump	Poor sealing
			Radiator cap	Loose
Poor sealing				
Radiator		O-ring for damage, deterioration or improper fitting		
		Cracked radiator tank		
		Cracked radiator core		
Reservoir tank	Cracked reservoir tank			
Overflowing reservoir tank	Exhaust gas leakage into cooling system	Cylinder head deterioration		
		Cylinder head gasket deterioration		

OVERHEATING CAUSE ANALYSIS

< SYMPTOM DIAGNOSIS >

[VQ35HR]

	Symptom		Check items				
Except cooling system parts malfunction	—	Overload on engine	Abusive driving	High engine rpm under no load	A		
				Driving in low gear for extended time	CO		
				Driving at extremely high speed			
					Powertrain system malfunction		C
					Installed improper size wheels and tires	—	D
					Dragging brakes		
			Improper ignition timing		E		
	Blocked or restricted air flow		Blocked bumper	—			
		Blocked radiator grille		Installed car brassiere			
				Mud contamination or paper clogging	—	F	
			Blocked radiator	—			
			Blocked condenser			G	
	Installed large fog lamp	Blocked air flow					

A
CO
C
D
E
F
G
H
I
J
K
L
M
N
O
P

PRECAUTION

PRECAUTIONS

Precaution for Supplemental Restraint System (SRS) "AIR BAG" and "SEAT BELT PRE-TENSIONER"

INFOID:000000007795673

The Supplemental Restraint System such as "AIR BAG" and "SEAT BELT PRE-TENSIONER", used along with a front seat belt, helps to reduce the risk or severity of injury to the driver and front passenger for certain types of collision. This system includes seat belt switch inputs and dual stage front air bag modules. The SRS system uses the seat belt switches to determine the front air bag deployment, and may only deploy one front air bag, depending on the severity of a collision and whether the front occupants are belted or unbelted. Information necessary to service the system safely is included in the "SRS AIR BAG" and "SEAT BELT" of this Service Manual.

WARNING:

Always observe the following items for preventing accidental activation.

- To avoid rendering the SRS inoperative, which could increase the risk of personal injury or death in the event of a collision that would result in air bag inflation, all maintenance must be performed by an authorized NISSAN/INFINITI dealer.
- Improper maintenance, including incorrect removal and installation of the SRS, can lead to personal injury caused by unintentional activation of the system. For removal of Spiral Cable and Air Bag Module, see "SRS AIR BAG".
- Never use electrical test equipment on any circuit related to the SRS unless instructed to in this Service Manual. SRS wiring harnesses can be identified by yellow and/or orange harnesses or harness connectors.

PRECAUTIONS WHEN USING POWER TOOLS (AIR OR ELECTRIC) AND HAMMERS

WARNING:

Always observe the following items for preventing accidental activation.

- When working near the Air Bag Diagnosis Sensor Unit or other Air Bag System sensors with the ignition ON or engine running, never use air or electric power tools or strike near the sensor(s) with a hammer. Heavy vibration could activate the sensor(s) and deploy the air bag(s), possibly causing serious injury.
- When using air or electric power tools or hammers, always switch the ignition OFF, disconnect the battery, and wait at least 3 minutes before performing any service.

PREPARATION

< PREPARATION >

[VQ35HR]

PREPARATION

PREPARATION

Commercial Service Tools

INFOID:000000007512276

A

CO

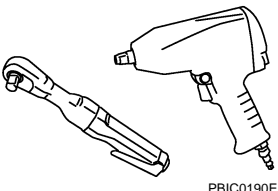
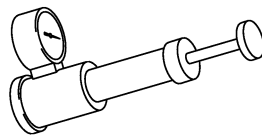
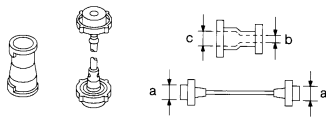
Tool name	Description
<p>Power tool</p>  <p>PBI0190E</p>	<p>Loosening bolts and nuts</p>
<p>Radiator cap tester</p>  <p>PBI1982E</p>	<p>Checking radiator and radiator cap</p>
<p>Radiator cap tester adapter</p>  <p>S-NT564</p>	<p>Adapting radiator cap tester to radiator cap and water outlet (front) filler neck a: 28 (1.10) dia. b: 31.4 (1.236) dia. c: 41.3 (1.626) dia. Unit: mm (in)</p>

C

D

E

F

G

H

I

J

K

L

M

N

O

P

PERIODIC MAINTENANCE

ENGINE COOLANT

Inspection

INFOID:000000007512277

LEVEL

- Check if the reservoir tank engine coolant level is within the “MIN” to “MAX” when the engine is cool.

A : MAX

B : MIN

- Adjust the engine coolant level as necessary.

CAUTION:

Refill Genuine NISSAN Long Life Antifreeze/Coolant (blue) or equivalent in its quality mixed with water (distilled or demineralized). Refer to [MA-17, "FOR NORTH AMERICA : Fluids and Lubricants"](#).

- Check that the reservoir tank cap is tightened.

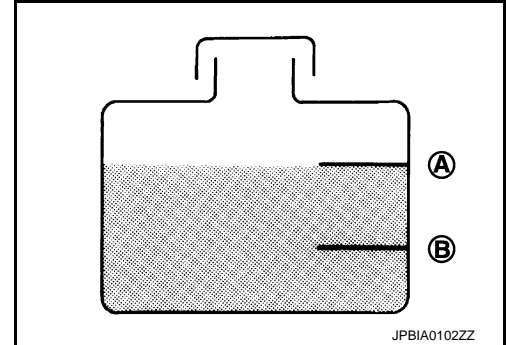

LEAKAGE

- To check for leakage, apply pressure to the cooling system with the radiator cap tester and radiator cap tester adapter (commercial service tool) (A).

Testing pressure : Refer to [CO-27, "Radiator"](#).

WARNING:

Never remove radiator cap when engine is hot. Serious burns could occur from high-pressure engine coolant escaping from water outlet (front).

CAUTION:

Higher test pressure than specified may cause radiator damage.

NOTE:

In a case that engine coolant decreases, fill radiator with engine coolant.

- If anything is found, repair or replace damaged parts.

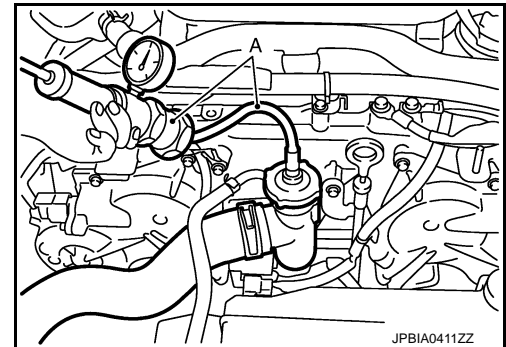

Draining

INFOID:000000007512278

WARNING:

- Never change engine coolant when the engine is hot to avoid being scalded.
- Wrap a thick cloth around radiator cap and carefully remove radiator cap. First, turn radiator cap a quarter of a turn to release built-up pressure. Then turn radiator cap all the way.

1. Connect drain hose.

NOTE:

Use general-purpose hose with the dimensions shown in the figure.

A : ϕ 15 - 16 mm (0.59 - 0.63 in)

B : 145 mm (5.71 in)

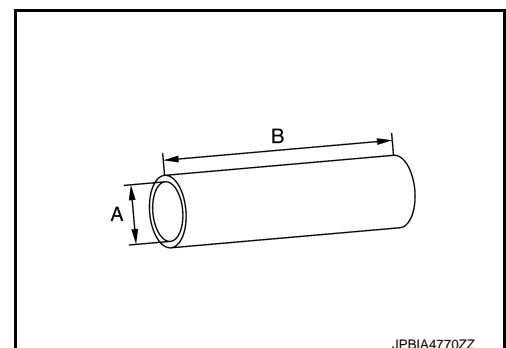

ENGINE COOLANT

[VQ35HR]

< PERIODIC MAINTENANCE >

- Open radiator drain plug (2) at the bottom of radiator, and then remove radiator cap.

- 1 : Engine under cover
A : Radiator drain plug hole
⇐ : Vehicle front

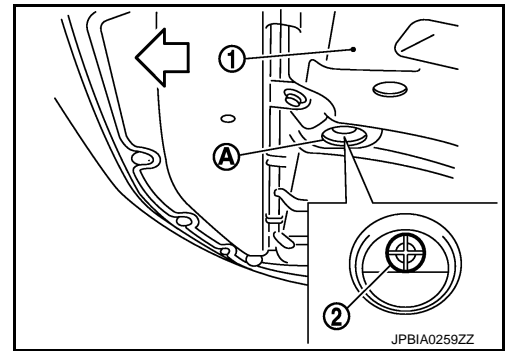

When draining all of engine coolant in the system, open water drain plugs on cylinder block. Refer to [EM-93, "Setting"](#).

- Remove reservoir tank as necessary, and drain engine coolant and clean reservoir tank before installing.
- Check drained engine coolant for contaminants such as rust, corrosion or discoloration. If contaminated, flush the engine cooling system. Refer to [CO-11, "Flushing"](#).
- Disconnect drain hose.

Refilling

INFOID:000000007512279

CAUTION:

- Do not reuse O-rings.
- Do not put additive such as waterleak preventive, since it may cause cooling waterway clogging.
- Refill Genuine NISSAN Long Life Antifreeze/Coolant (blue) or equivalent in its quality mixed with water (distilled or demineralized). Refer to [MA-17, "FOR NORTH AMERICA : Fluids and Lubricants"](#).

- Remove engine cover. Refer to [EM-26, "Exploded View"](#).
- Install reservoir tank if removed, and radiator drain plug.

CAUTION:

Be sure to clean drain plug and install with new O-ring.

Tightening torque : Refer to [CO-14, "Exploded View"](#).

If water drain plugs on cylinder block are removed, close and tighten them. Refer to [EM-120, "Disassembly and Assembly"](#).

- Check that each hose clamp is firmly tightened.
- Remove air relief plug (2) on radiator left side.

- 1 : Reservoir tank
3 : Engine cover
⇐ : Vehicle front

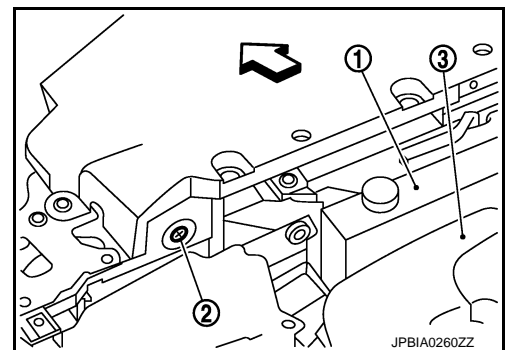

ENGINE COOLANT

[VQ35HR]

< PERIODIC MAINTENANCE >

5. Remove air relief plug (1) on heater hose. (models with air relief plug on heater hose)

2 : Heater hose

↔ : Vehicle front

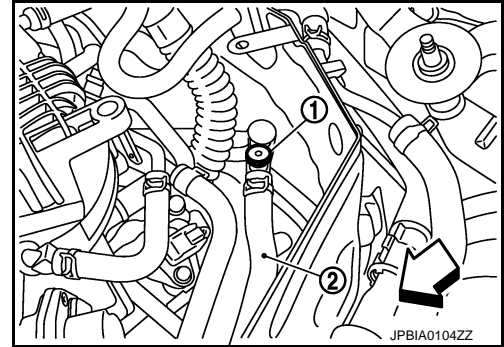

6. Fill radiator, and reservoir tank if removed, to specified level.
- Pour engine coolant through engine coolant filler neck slowly of less than 2 ℓ (2-1/8 US qt, 1-3/4 Imp qt) a minute to allow air in system to escape.

Engine coolant capacity
(With reservoir tank at
"MAX" level)

: Refer to [CO-27,](#)
["Periodical Maintenance Specification".](#)

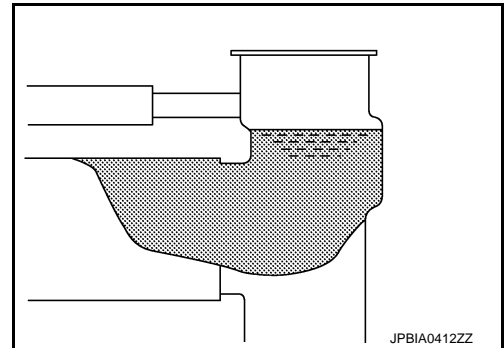

Reservoir tank engine coolant capacity
(At "MAX" level)

: Refer to [CO-27,](#)
["Periodical Maintenance Specification".](#)

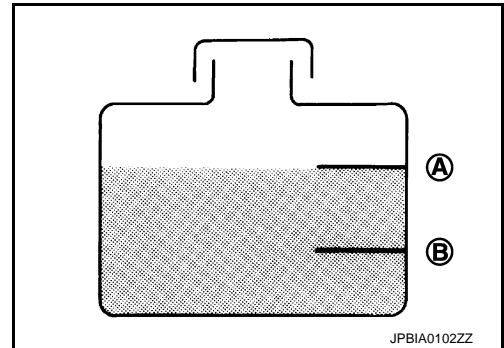

7. When engine coolant overflows air relief hole on radiator, install air relief plug with new O-ring.

CAUTION:
Do not reuse O-ring.

Tightening torque : Refer to [CO-14, "Exploded View".](#)

8. Repeat step 6.
9. When engine coolant overflows air relief hole on heater hose, install air relief plug with new O-ring. Then refill radiator with engine coolant. (models with air relief plug on heater hose)

CAUTION:
Do not reuse O-ring.

 : 1.2 N·m (0.12 kg·m, 11 in·lb)

10. Install radiator cap.
11. Warm up engine until opening thermostat. Standard for warming-up time is approximately 10 minutes at 3,000 rpm.
- Check thermostat opening condition by touching radiator hose (lower) to see a flow of warm water.
- CAUTION:**
Watch water temperature gauge so as not to overheat engine.
12. Stop the engine and cool down to less than approximately 50°C (122°F).
- Cool down using fan to reduce the time.
 - If necessary, refill radiator up to filler neck with engine coolant.

ENGINE COOLANT

< PERIODIC MAINTENANCE >

[VQ35HR]

13. Refill reservoir tank to "MAX" level line with engine coolant.
14. Repeat steps 10 through 13 two or more times with radiator cap installed until engine coolant level no longer drops.
15. Check cooling system for leakage with engine running.
16. Warm up the engine, and check for sound of engine coolant flow while running engine from idle up to 3,000 rpm with heater temperature controller set at several position between "COOL" and "WARM".
 - Sound may be heard from the heater unit.
17. Repeat step 16 three times.
18. If sound is heard, bleed air from cooling system by repeating step 6, and steps from 10 to 17 until engine coolant level no longer drops.
19. Check that the reservoir tank cap is tightened.

Flushing

INFOID:000000007512280

1. Install reservoir tank if removed, and radiator drain plug.
CAUTION:
Be sure to clean drain plug and install with new O-ring.

Tightening torque : Refer to [CO-14, "Exploded View"](#).

If water drain plugs on cylinder block are removed, close and tighten them. Refer to [EM-120, "Disassembly and Assembly"](#).

2. Remove air relief plug (1) on heater hose. (models with air relief plug on heater hose)

- 2 : Heater hose
⇐ : Vehicle front

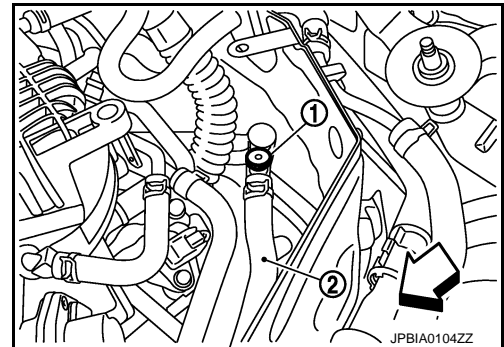

3. Remove air relief plug (2) on radiator.

- 1 : Reservoir tank
3 : Engine cover
⇐ : Vehicle front

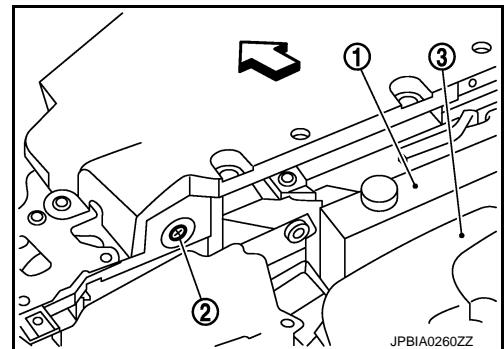

4. Fill radiator with water until water spills from the air relief holes, then close air relief plugs. Fill radiator and reservoir tank with water and reinstall radiator cap.

Tightening torque : Refer to [CO-14, "Exploded View"](#).

5. Run the engine and warm it up to normal operating temperature.
6. Rev the engine two or three times under no-load.
7. Stop the engine and wait until it cools down.
8. Drain water from the system. Refer to [CO-8, "Draining"](#).
9. Repeat steps 1 through 8 until clear water begins to drain from radiator.
10. Check that the reservoir tank cap is tightened.

RADIATOR RADIATOR CAP

RADIATOR CAP : Inspection

INFOID:000000007512281

- Check valve seat of radiator cap.
- Check if valve seat (A) is swollen to the extent that the edge of the metal plunger (B) cannot be seen when watching it vertically from the top.
- Check if valve seat has no soil and damage.

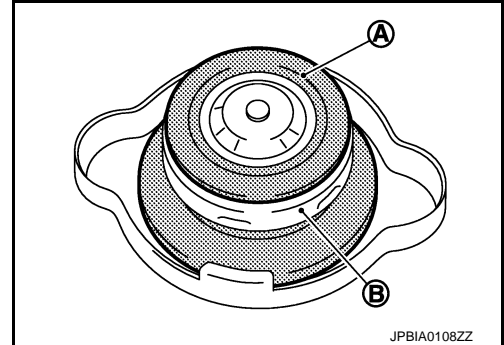

- Pull negative-pressure valve to open it, and check that it close completely when released.
- Check that there is no dirt or damage on the valve seat of radiator cap negative-pressure valve.
- Check that there are no unusualness in the opening and closing conditions of negative-pressure valve.

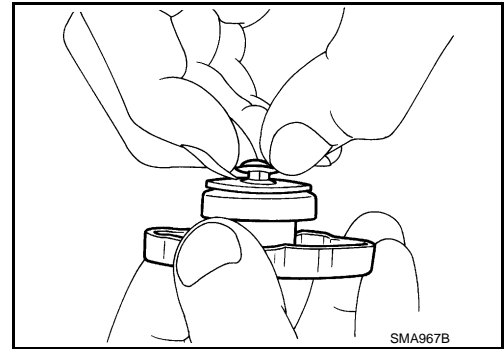

- Check radiator cap relief pressure.
- When connecting radiator cap to the radiator cap tester (commercial service tool) and the radiator cap tester adapter (commercial service tool) (A), apply engine coolant to the cap seal surface.

Standard and limit : Refer to [CO-27, "Radiator"](#).

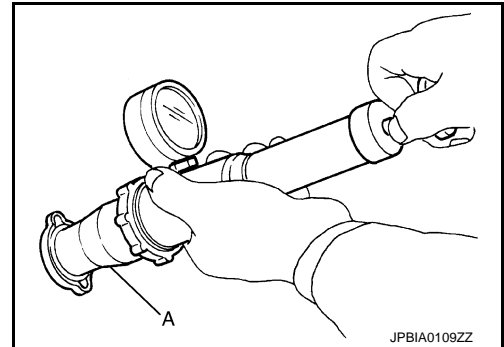

- Replace radiator cap if there is an unusualness related to the above three.

CAUTION:

When installing radiator cap, thoroughly wipe out the water outlet (front) filler neck to remove any waxy residue or foreign material.

RADIATOR

RADIATOR : Inspection

INFOID:000000007512282

Check radiator for mud or clogging. If necessary, clean radiator as per the following:

- Be careful not to bend or damage radiator fins.
 - When radiator is cleaned without removal, remove all surrounding parts such as radiator cooling fan assembly and horns. Then tape harness and connectors to prevent water from entering.
1. Apply water by hose to the back side of the radiator core vertically downward.
 2. Apply water again to all radiator core surfaces once per minute.

RADIATOR

[VQ35HR]

< PERIODIC MAINTENANCE >

3. Stop washing if any stains no longer flow out from radiator.
4. Blow air into the back side of radiator core vertically downward.
 - Use compressed air lower than 490 kPa (5 kg/cm², 71 psi) and keep distance more than 30 cm (11.8 in).
5. Blow air again into all the radiator core surfaces once per minute until no water sprays out.

A

CO

C

D

E

F

G

H

I

J

K

L

M

N

O

P

RADIATOR

< REMOVAL AND INSTALLATION >

[VQ35HR]

REMOVAL AND INSTALLATION

RADIATOR

Exploded View

INFOID:000000007512283

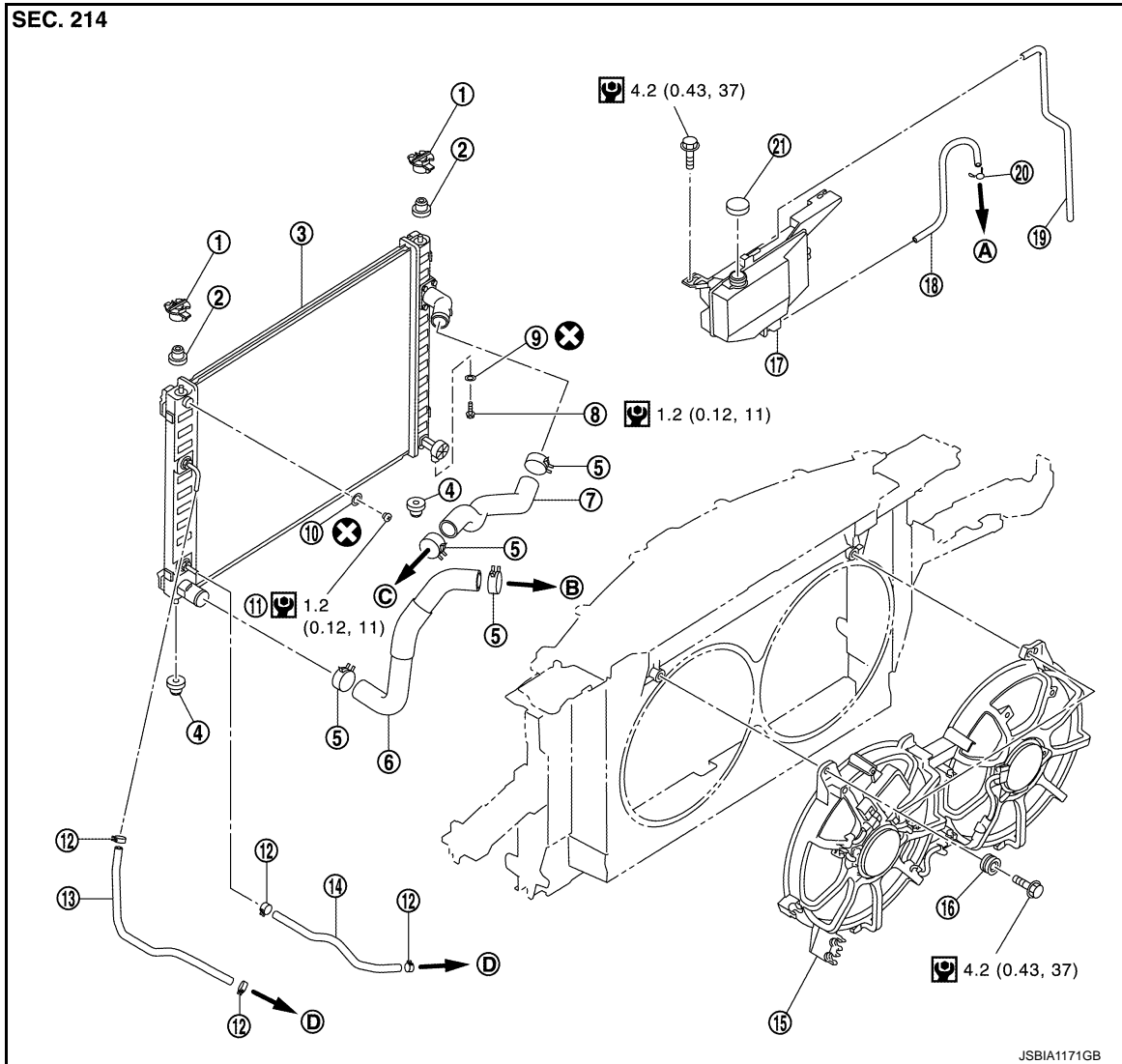

- | | | |
|-----------------------------|----------------------------|----------------------------|
| 1. Upper mount bracket | 2. Mounting rubber (upper) | 3. Radiator |
| 4. Mounting rubber (lower) | 5. Clamp | 6. Radiator hose (lower) |
| 7. Radiator hose (upper) | 8. Drain plug | 9. O-ring |
| 10. O-ring | 11. Air relief plug | 12. Clamp |
| 13. A/T fluid cooler hose | 14. A/T fluid cooler hose | 15. Cooling fan assembly |
| 16. Grommet | 17. Reservoir tank | 18. Reservoir tank hose |
| 19. Reservoir tank hose | 20. Clamp | 21. Reservoir tank cap |
| A. To water outlet (front) | B. To water inlet | C. To water outlet (front) |
| D. To A/T fluid cooler pipe | | |

Refer to [GI-4, "Components"](#) for symbols in the figure.

Removal and Installation

INFOID:000000007512284

REMOVAL

WARNING:

RADIATOR

< REMOVAL AND INSTALLATION >

[VQ35HR]

Never remove radiator cap when engine is hot. Serious burns could occur from high-pressure engine coolant escaping from water outlet (front). Wrap a thick cloth around the cap. Slowly turn it a quarter of a turn to release built-up pressure. Carefully remove radiator cap by turning it all the way.

1. Remove the following parts:
 - Engine under cover, using a power tool.
 - Engine cover: Refer to [EM-26, "Exploded View"](#).
 - Air cleaner case: Refer to [EM-28, "Exploded View"](#).
 - Air duct (inlet): Refer to [EM-28, "Exploded View"](#).
 - Hood lock stay assembly and horn: Refer to [DLK-291, "Exploded View"](#) and [HRN-4, "Exploded View"](#).
2. Remove condenser. Refer to [HA-49, "Exploded View"](#).
3. Drain engine coolant from radiator. Refer to [CO-8, "Draining"](#).

CAUTION:

- Perform this step when the engine is cold.
- Never spill engine coolant on drive belt.

4. Disconnect A/T fluid cooler hoses from radiator.
 - Install blind plug to avoid leakage of A/T fluid.
5. Remove radiator hoses (upper and lower) and reservoir tank hose.

CAUTION:

- Be careful not to allow engine coolant to contact drive belt.
- Never loosen radiator water inlet pipe mounting screw (A). If loosened, replace radiator (1).

2 : Radiator water inlet pipe

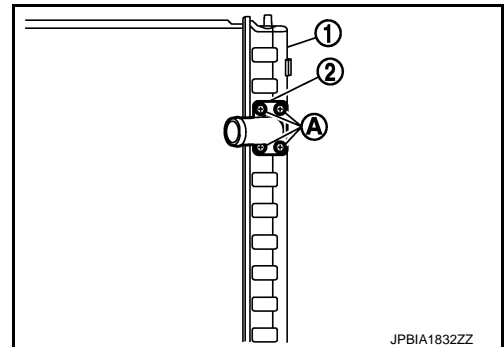

6. Rotate two radiator upper mount brackets 90 degrees in direction as shown in the figure, and remove them.

1 : Radiator upper mount bracket

A : Turn 90° counterclockwise

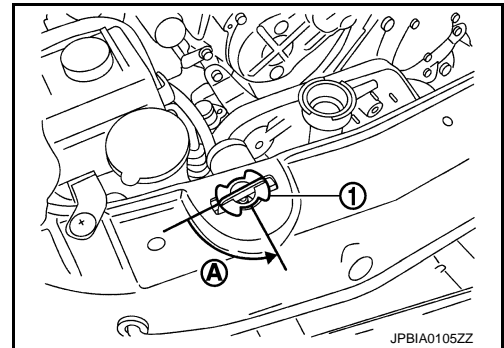

7. Remove radiator as per the following:

CAUTION:

Be careful not to damage radiator core.

- a. Lift up and pull the radiator (1) forward, and then remove the mounting rubber (lower) (3) from the radiator core support (2).

← : Vehicle front

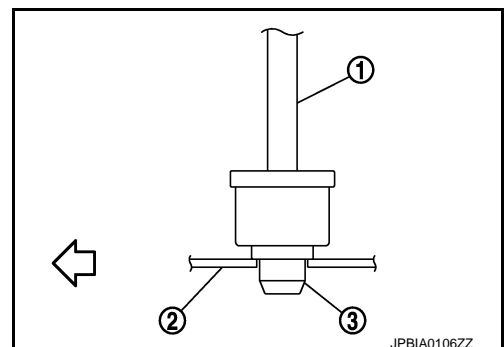

RADIATOR

< REMOVAL AND INSTALLATION >

[VQ35HR]

b. Remove radiator (1) from front of radiator core support (2).

↔ : Vehicle front

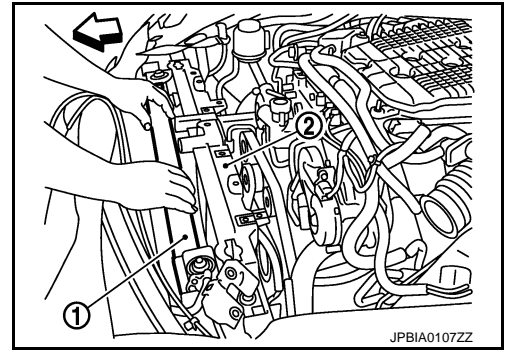

INSTALLATION

Note the following, and install in the reverse order of removal.

CAUTION:

- Do not reuse O-rings.
- Replace water hose clamp if it is removed.
- Use genuine mounting bolts for the cooling fan assembly and strictly observe the tightening torque. (Breakage prevention for radiator)

NOTE:

- Insert the radiator hose (1) all the way to the stopper (2) or by 33 mm (1.30 in) (hose without a stopper).

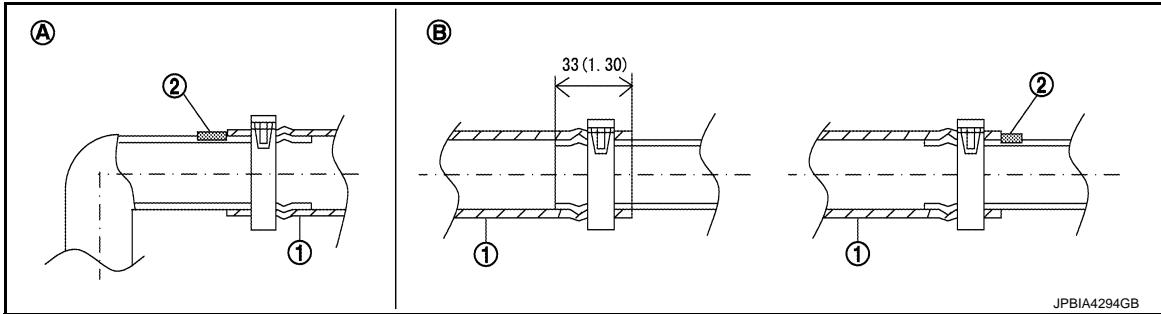

Unit mm (in)

A. Radiator side

B. Engine side

- For the orientation of the hose clamp pawl, refer to the figure.

Radiator hose	Hose end	Paint mark	Position of hose clamp*
Radiator hose (upper)	Radiator side	Upper	A
	Engine side	Upper	B
Radiator hose (lower)	Radiator side	Lower	C
	Engine side	Right side	D

*Refer to the illustrations for the specific position each hose clamp tab.

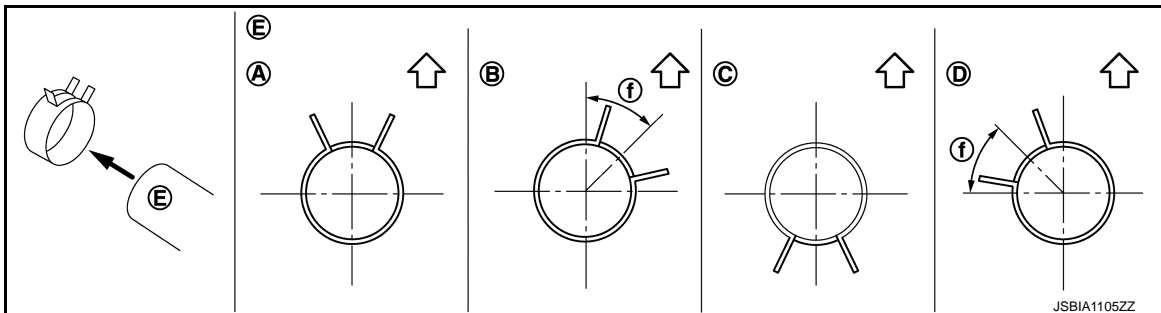

E. View E

f. 45°

↔ Vehicle upper

RADIATOR

[VQ35HR]

< REMOVAL AND INSTALLATION >

- The angle (b) created by the hose clamp pawl and the specified line (A) must be within $\pm 30^\circ$ as shown in the figure.

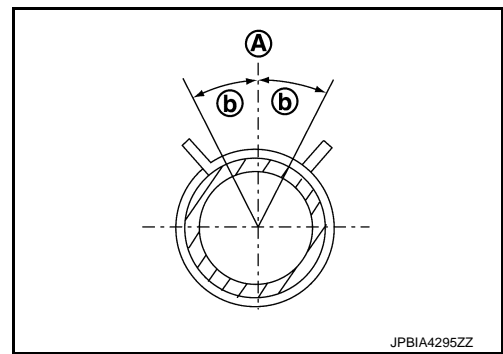

- To install hose clamps (1), check that the dimension (A) from the end of the paint mark (2) on the radiator hose to the hose clamp is within the reference value.

Dimension "A" : (-1) – (+1) mm
(-0.04) – (+0.04) in

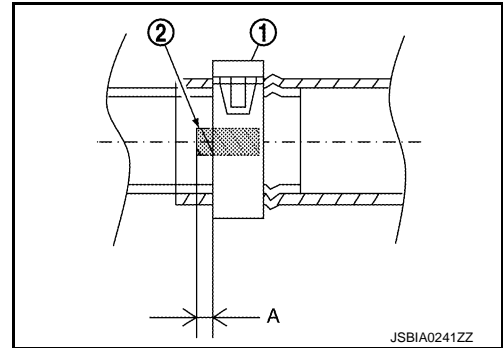

Inspection

INFOID:000000007512285

INSPECTION AFTER INSTALLATION

- Check for leakage of engine coolant using the radiator cap tester adapter (commercial service tool) and the radiator cap tester (commercial service tool). Refer to [CO-34. "Inspection"](#).
- Start and warm up the engine. Visually check that there is no leakage of engine coolant and A/T fluid.

COOLING FAN

< REMOVAL AND INSTALLATION >

[VQ35HR]

COOLING FAN

Exploded View

INFOID:000000007512286

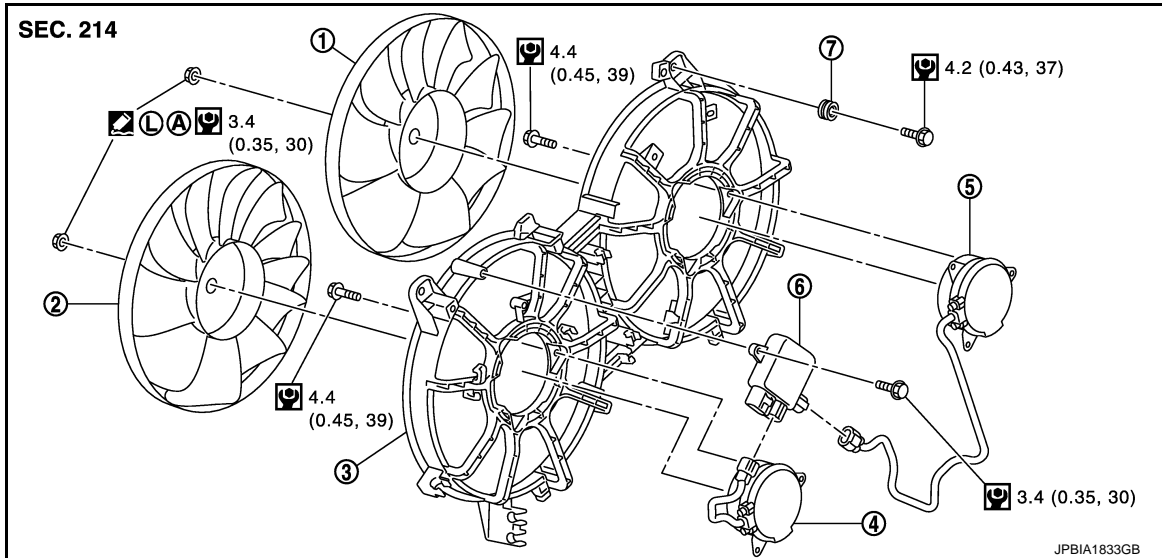

- | | | |
|-----------------------------|---------------------|-------------------------------|
| 1. Cooling fan (RH) | 2. Cooling fan (LH) | 3. Fan shroud |
| 4. Fan motor (LH) | 5. Fan motor (RH) | 6. Cooling fan control module |
| 7. Grommet | | |
| A. Apply on fan motor shaft | | |

: Apply high strength thread locking sealant or equivalent.

Refer to [GI-4, "Components"](#) for symbols not described on the above.

Removal and Installation

INFOID:000000007512287

REMOVAL

1. Drain engine coolant. Refer to [CO-8, "Draining"](#).
2. Remove reservoir tank. Refer to [CO-14, "Exploded View"](#).
3. Remove air cleaner case (bank 1 and bank 2). Refer to [EM-28, "Exploded View"](#).
4. Remove mounting bolt from high pressure flexible hose bracket. Refer to [HA-42, "Exploded View"](#).
5. Remove radiator hose (upper). Refer to [CO-14, "Exploded View"](#).
6. Disconnect harness connector from cooling fan control module, and move harness to aside.
7. Remove cooling fan assembly.

CAUTION:

Be careful not to damage or scratch on radiator core.

INSTALLATION

Note the following, and install in the reverse order of removal.

CAUTION:

Only use genuine parts for cooling fan mounting bolt and observe the specified torque (to prevent radiator from being damaged).

Disassembly and Assembly

INFOID:000000007512288

DISASSEMBLY

1. Disconnect harness connector from cooling fan control module.
2. Remove cooling fan control module from cooling fan assembly.

CAUTION:

Handle carefully to avoid dropping and impact.

COOLING FAN

[VQ35HR]

< REMOVAL AND INSTALLATION >

3. Remove cooling fan mounting nuts, and then remove the cooling fan (RH and LH).
4. Remove fan motors (RH and LH).

ASSEMBLY

Note the following, and assemble in the reverse order of disassembly.

CAUTION:

RH and LH cooling fans are different. Be careful not to misassemble them.

- Install each fan in the following position.

Right side : 9 blades

Left side : 11 blades

- Secure the harness tightly to the fan shroud to prevent the fan rotation area from being slack.

Inspection

INFOID:000000007512289

INSPECTION AFTER REMOVAL

Check that fan motors operate normally.

NOTE:

Cooling fans are controlled by cooling fan control module. For details, refer to [EC-479. "Description"](#).

INSPECTION AFTER DISASSEMBLY

Cooling Fan

Inspect cooling fan for crack or unusual bend.

- If anything is found, replace cooling fan.

A

CO

C

D

E

F

G

H

I

J

K

L

M

N

O

P

WATER PUMP

< REMOVAL AND INSTALLATION >

[VQ35HR]

WATER PUMP

Exploded View

INFOID:000000007512290

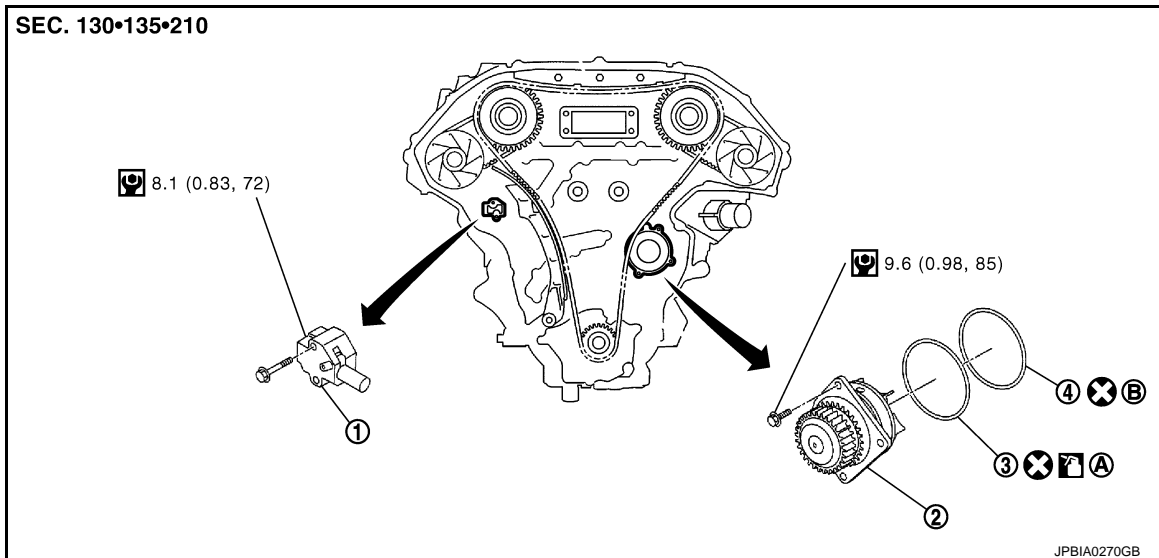

- | | | |
|-------------------------------------|--|----------------------|
| 1. Timing chain tensioner (primary) | 2. Water pump | 3. O-ring |
| 4. O-ring | | |
| A. Identify with yellow paint mark | B. Identify with light blue paint mark | Apply engine coolant |

Refer to [GI-4, "Components"](#) for symbols in the figure.

Removal and Installation

INFOID:000000007512291

CAUTION:

- When removing water pump assembly, be careful not to get engine coolant on drive belt.
- Water pump cannot be disassembled and should be replaced as a unit.
- After installing water pump, connect hose and clamp securely, then check for leakage using the radiator cap tester (commercial service tool) and the radiator cap tester adapter (commercial service tool).

REMOVAL

1. Remove engine cover. Refer to [EM-26, "Exploded View"](#).
2. Release the fuel pressure. Refer to [EC-564, "Inspection"](#).
3. Disconnect the battery cable from the negative terminal.
4. Remove air duct and air cleaner case assembly (bank 1 and bank 2). Refer to [EM-28, "Exploded View"](#).
5. Remove reservoir tank. Refer to [CO-14, "Exploded View"](#).
6. Separate engine harness removing their brackets from front timing chain case.
7. Remove engine undercover with a power tool.
8. Drain engine oil. Refer to [LU-9, "Draining"](#).
CAUTION:
 - Perform this step when the engine is cold.
 - Never spill engine oil on drive belt.
9. Drain engine coolant from radiator. Refer to [CO-8, "Draining"](#).
CAUTION:
 - Perform this step when the engine is cold.
 - Never spill engine coolant on drive belt.
10. Remove radiator hose (lower). Refer to [CO-14, "Exploded View"](#).
11. Remove cooling fan assembly. Refer to [CO-18, "Exploded View"](#).
12. Remove front timing chain case. Refer to [EM-52, "Exploded View"](#).

WATER PUMP

[VQ35HR]

< REMOVAL AND INSTALLATION >

13. Remove timing chain tensioner (primary) as per the following:

- Remove lower mounting bolt (A).
- Loosen upper mounting bolt (B) slowly, and then turn chain tensioner (primary) (1) on the upper mounting bolt so that plunger (C) is fully expanded.

NOTE:

Even if plunger is fully expanded, it is not dropped from the body of timing chain tensioner (primary).

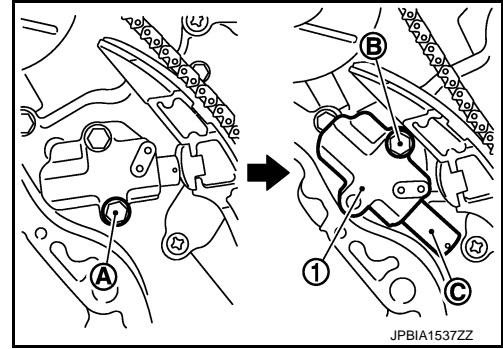

c. Remove upper mounting bolt, and then remove timing chain tensioner (primary).

14. Remove water pump as per the following:

a. Remove three water pump mounting bolts. Secure a gap between water pump gear and timing chain, by turning crankshaft counterclockwise until timing chain looseness on water pump sprocket becomes maximum.

b. Screw M8 bolts (A) [pitch: 1.25 mm (0.0492 in) length: approximately 50 mm (1.97 in)] into water pumps upper and lower mounting bolt holes until they reach timing chain case. Then, alternately tighten each bolt for a half turn, and pull out water pump (1).

CAUTION:

- Pull straight out while preventing vane from contacting socket in installation area.
- Remove water pump without causing sprocket to contact timing chain.

c. Remove M8 bolts and O-rings from water pump.

CAUTION:

Never disassemble water pump.

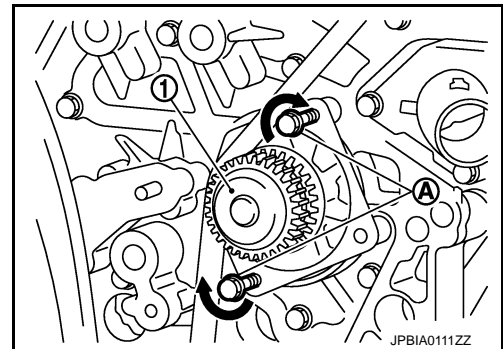

INSTALLATION

CAUTION:

Do not reuse O-rings.

1. Install new O-rings to water pump.

CAUTION:

Do not reuse O-rings.

- Apply engine oil to O-ring (1) and engine coolant to O-ring (3) as shown in the figure.

2 : Water pump

- Locate O-ring with yellow paint mark (A) to front side.
- Locate O-ring with light blue paint mark (B) to rear side.

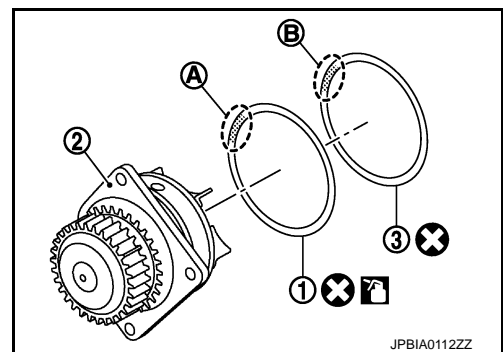

2. Install water pump.

CAUTION:

Never allow cylinder block to nip O-rings when installing water pump.

- Check timing chain and water pump sprocket are engaged.
- Insert water pump by tightening mounting bolts alternately and evenly.

3. Install timing chain tensioner (primary) as per the following:

a. Turn crankshaft clockwise so that timing chain on the timing chain tensioner (primary) side is loose.

WATER PUMP

< REMOVAL AND INSTALLATION >

[VQ35HR]

- b. Pull plunger stopper tab (A) up (or turn lever downward) so as to remove plunger stopper tab from the ratchet of plunger (D).

NOTE:

Plunger stopper tab and lever (C) are synchronized.

- c. Push plunger into the inside of tensioner body.
d. Hold plunger in the fully compressed position by engaging plunger stopper tab with the tip of ratchet.
e. To secure lever, insert stopper pin (E) through hole of lever into tensioner body hole (B).
• The lever parts and the tab are synchronized. Therefore, the plunger will be secured under this condition.

NOTE:

Figure shows the example of 1.2 mm (0.047 in) diameter thin screwdriver being used as the stopper pin.

- f. Install timing chain tensioner (primary).
• Remove dust and foreign material completely from backside of timing chain tensioner (primary) and from installation area of rear timing chain case.
g. Remove stopper pin.
h. Check again that timing chain and water pump sprocket are engaged.
4. Install in the reverse order of removal for remaining parts.
• **After starting engine, let idle for three minutes, then rev engine up to 3,000 rpm under no load to purge air from the high-pressure chamber of chain tensioner. Engine may produce a rattling noise. This indicates that air still remains in the chamber and is not a matter of concern.**

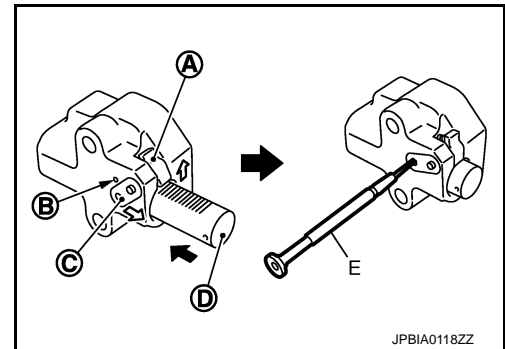

Inspection

INFOID:000000007512292

INSPECTION AFTER REMOVAL

- Check for badly rusted or corroded water pump body assembly.
- Check for rough operation due to excessive end play.
- If anything is found, replace water pump.

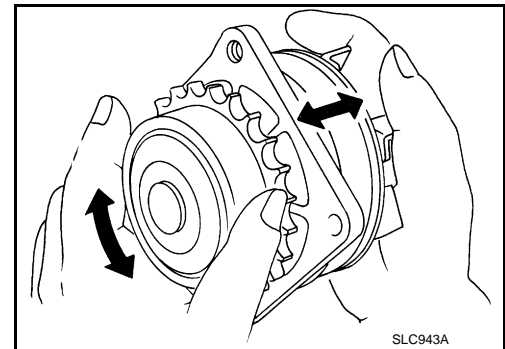

INSPECTION AFTER INSTALLATION

- Check that the reservoir tank cap is tightened.
- Check for leakage of engine coolant using the radiator cap tester adapter (commercial service tool) and the radiator cap tester (commercial service tool). Refer to [CO-34, "Inspection"](#).
- Start and warm up the engine. Visually check that there is no leakage of engine coolant.

WATER INLET AND THERMOSTAT ASSEMBLY

< REMOVAL AND INSTALLATION >

[VQ35HR]

WATER INLET AND THERMOSTAT ASSEMBLY

Exploded View

INFOID:000000007512293

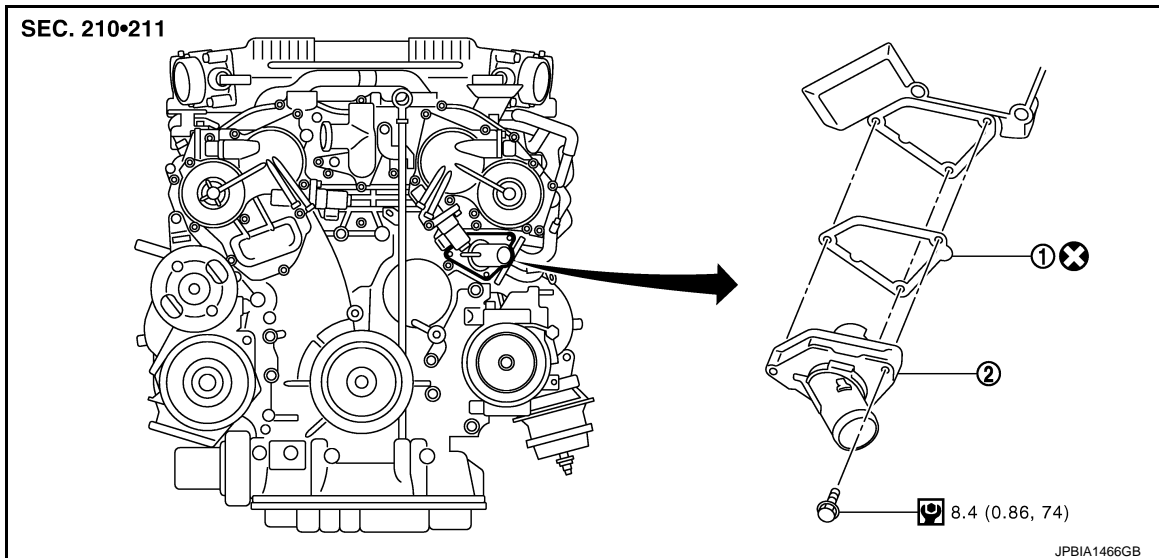

1. Gasket
2. Water inlet and thermostat assembly

Refer to [GI-4, "Components"](#) for symbols in the figure.

Removal and Installation

INFOID:000000007512294

REMOVAL

1. Remove engine cover. Refer to [EM-26, "Exploded View"](#).
2. Remove air duct and air cleaner case assembly (bank 2). Refer to [EM-28, "Exploded View"](#).
3. Remove reservoir tank. Refer to [CO-14, "Exploded View"](#).
4. Remove engine undercover with a power tool.
5. Drain engine coolant from radiator drain plug at the bottom of radiator. Refer to [CO-8, "Draining"](#).
CAUTION:
 - Perform this step when the engine is cold.
 - Never spill engine coolant on drive belt.
6. Disconnect radiator hose (lower).
7. Disconnect intake valve timing control solenoid valve harness connector (bank 2), and remove intake valve timing control solenoid valve.
8. Remove water inlet and thermostat assembly (1).

A : Never loosen these screws.

CAUTION:

Never disassemble water inlet and thermostat assembly.
Replace them as a unit, if necessary.

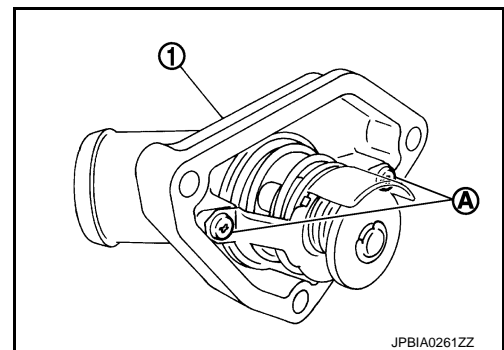

INSTALLATION

Note the following, and install in the reverse order of removal.

- Be careful not to spill engine coolant over engine room. Use rag to absorb engine coolant.

WATER INLET AND THERMOSTAT ASSEMBLY

< REMOVAL AND INSTALLATION >

[VQ35HR]

Inspection

INFOID:000000007512295

INSPECTION AFTER REMOVAL

1. Check valve seating condition at ordinary room temperatures. It should seat tightly.
2. Check valve operation.

Thermostat (Standard) : Refer to [CO-27, "Thermostat"](#).

- If the malfunctioning condition, when valve seating at ordinary room temperature, or measured values are out of the standard, replace water inlet and thermostat assembly.

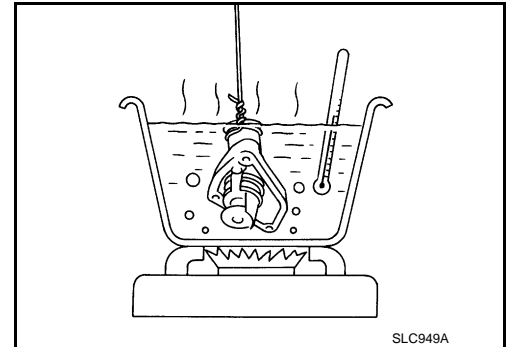

INSPECTION AFTER INSTALLATION

- Check that the reservoir tank cap is tightened.
- Check for leakage of engine coolant using the radiator cap tester adapter (commercial service tool) and the radiator cap tester (commercial service tool). Refer to [CO-8, "Inspection"](#).
- Start and warm up the engine. Visually check that there is no leakage of engine coolant.

WATER OUTLET AND WATER PIPING

< REMOVAL AND INSTALLATION >

[VQ35HR]

WATER OUTLET AND WATER PIPING

Exploded View

INFOID:000000007512296

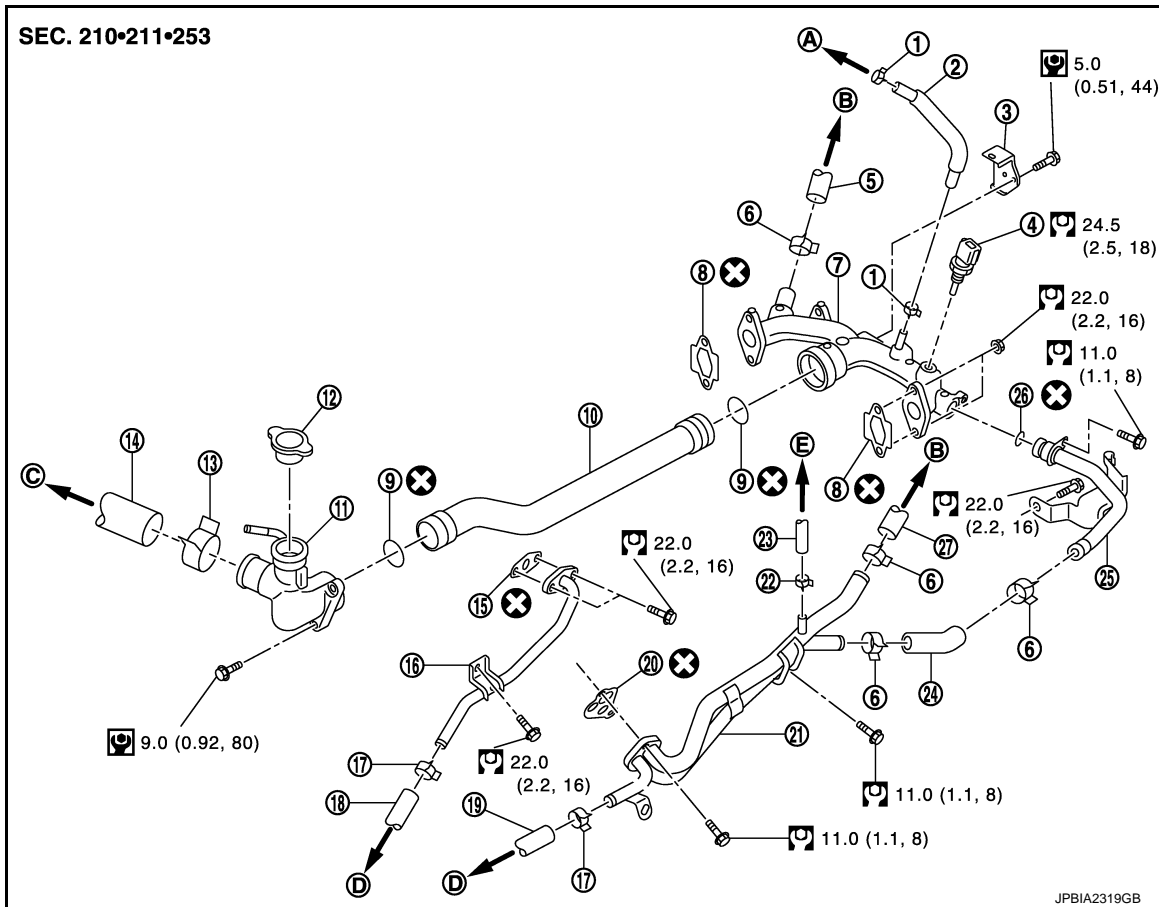

- | | | |
|---|---|--------------------|
| 1. Clamp | 2. Water hose | 3. Harness bracket |
| 4. Engine coolant temperature sensor | 5. Heater hose | 6. Clamp |
| 7. Water outlet (rear) | 8. Gasket | 9. O-ring |
| 10. Water outlet pipe | 11. Water outlet (front) | 12. Radiator cap |
| 13. Clamp | 14. Radiator hose (upper) | 15. Gasket |
| 16. Water pipe | 17. Clamp | 18. Water hose |
| 19. Water hose | 20. Gasket | 21. Heater pipe |
| 22. Clamp | 23. Water hose | 24. Water hose |
| 25. Water bypass pipe | 26. O-ring | 27. Heater hose |
| A. To electric throttle control actuator (bank 1) | B. To heater core | C. To radiator |
| D. To oil cooler | E. To electric throttle control actuator (bank 2) | |

Refer to [GI-4, "Components"](#) for symbols in the figure.

Removal and Installation

INFOID:000000007512297

REMOVAL

1. Remove engine undercover with a power tool.
2. Drain engine coolant from drain plugs on radiator and cylinder block. Refer to [CO-8, "Draining"](#) and [EM-93, "Setting"](#).

CAUTION:

- Perform this step when the engine is cold.

WATER OUTLET AND WATER PIPING

[VQ35HR]

< REMOVAL AND INSTALLATION >

- **Never spill engine coolant on drive belt.**

3. Remove engine cover. Refer to [EM-26, "Exploded View"](#).
4. Remove air duct and air cleaner case assembly. Refer to [EM-28, "Exploded View"](#).
5. Remove intake manifold collector. Refer to [EM-30, "Exploded View"](#).
6. Remove intake manifold. Refer to [EM-33, "Exploded View"](#).
7. Remove reservoir tank. Refer to [CO-14, "Exploded View"](#).
8. Remove oil level gauge and guide. Refer to [EM-45, "Exploded View"](#).
9. Remove radiator hose (upper) and heater hose.
10. Remove water outlet (front) and water outlet pipe.
11. Remove water outlet (rear).
12. Separate engine harness removing their bracket from water outlet (rear).
13. Remove engine coolant temperature sensor if necessary.

CAUTION:

Be careful not to damage engine coolant temperature sensor.

14. Remove water pipe, heater pipe, water bypass pipe, and water outlet (rear).

INSTALLATION

Note the following, and install in the reverse order of removal.

CAUTION:

- **Do not reuse O-rings.**
- **Never allow water outlet (rear) to nip O-rings when installing water outlet pipe and water bypass pipe.**
- Securely insert each hose, and install clamp at a position where it does not interfere with the pipe bulge.
- When inserting water outlet pipe and water bypass pipe into water outlet, apply neutral detergent to O-ring.

Inspection

INFOID:000000007512298

INSPECTION AFTER INSTALLATION

- Check that the reservoir tank cap is tightened.
- Check for leakage of engine coolant using the radiator cap tester adapter (commercial service tool) and the radiator cap tester (commercial service tool). Refer to [CO-8, "Inspection"](#).
- Start and warm up the engine. Visually check that there is no leakage of engine coolant.

SERVICE DATA AND SPECIFICATIONS (SDS)

< SERVICE DATA AND SPECIFICATIONS (SDS)

[VQ35HR]

SERVICE DATA AND SPECIFICATIONS (SDS)

SERVICE DATA AND SPECIFICATIONS (SDS)

Periodical Maintenance Specification

INFOID:0000000007512299

ENGINE COOLANT CAPACITY (APPROXIMATELY)

Unit: ℓ (US qt, Imp qt)

Engine coolant capacity [With reservoir tank ("MAX" level)]	9.2 (9-3/4, 8-1/8)
Reservoir tank engine coolant capacity (At "MAX" level)	0.8 (7/8, 3/4)

Radiator

INFOID:0000000007512300

Unit: kPa (kg/cm², psi)

Cap relief pressure	Standard	122.3 - 151.7 (1.2 - 1.5, 18 - 22)
	Limit	107 (1.1, 16)
Leakage testing pressure		157 (1.6, 23)

Thermostat

INFOID:0000000007512301

Thermostat	Standard
Valve opening temperature	82°C (180°F)
Maximum valve lift	9.0 mm/95°C (0.354 in/203°F)
Valve closing temperature	77°C (171°F)

A
CO
C
D
E
F
G
H
I
J
K
L
M
N
O
P

SYSTEM DESCRIPTION

DESCRIPTION

Engine Cooling System

INFOID:000000007512302

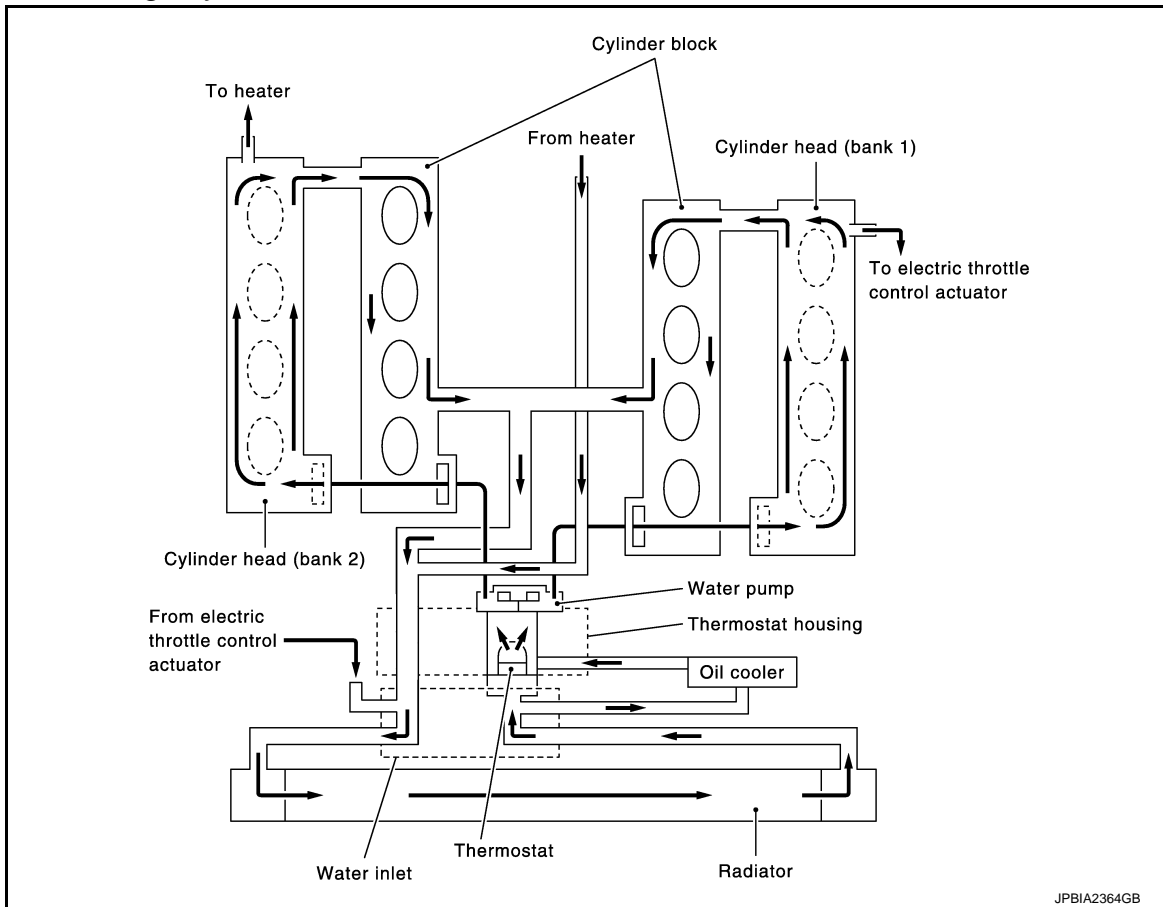

JPBIA2364GB

DESCRIPTION

< SYSTEM DESCRIPTION >

[VK50VE]

Engine Cooling System Schematic

INFOID:000000007512303

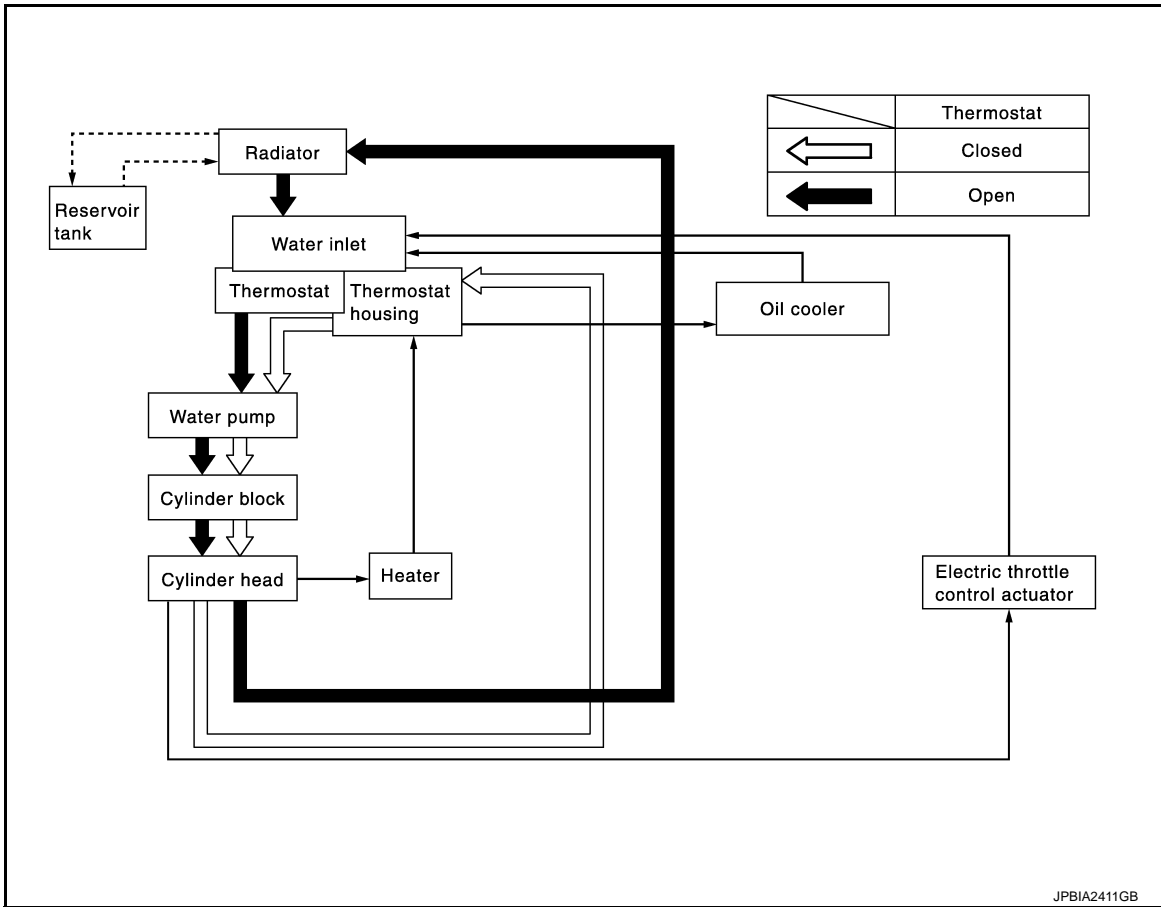

A
CO
C
D
E
F
G
H
I
J
K
L
M
N
O
P

OVERHEATING CAUSE ANALYSIS

< SYMPTOM DIAGNOSIS >

[VK50VE]

SYMPTOM DIAGNOSIS

OVERHEATING CAUSE ANALYSIS

Troubleshooting Chart

INFOID:000000007512304

	Symptom		Check items		
Cooling system parts malfunction	Poor heat transfer	Water pump malfunction	Worn or loose drive belt	—	
		Thermostat stuck closed	—		
		Damaged fins	Dust contamination or paper clogging		
			Physical damage		
		Clogged radiator cooling tube	Excess foreign material (rust, dirt, sand, etc.)		
	Reduced air flow	Cooling fan does not operate	Fan assembly	—	
		High resistance to fan rotation			
		Damaged fan blades			
		Damaged radiator shroud	—	—	
		Improper engine coolant mixture ratio	—	—	
		Poor engine coolant quality	—	Engine coolant density	—
	Insufficient engine coolant	Engine coolant leakage	Cooling hose	Loose clamp	
				Cracked hose	
			Water pump	Poor sealing	
			Radiator cap	Loose	
Poor sealing					
Radiator			O-ring for damage, deterioration or improper fitting		
		Cracked radiator tank			
		Cracked radiator core			
	Reservoir tank	Cracked reservoir tank			
Overflowing reservoir tank	Exhaust gas leakage into cooling system	Cylinder head deterioration			
		Cylinder head gasket deterioration			

OVERHEATING CAUSE ANALYSIS

< SYMPTOM DIAGNOSIS >

[VK50VE]

	Symptom		Check items			
Except cooling system parts malfunction	—	Overload on engine	Abusive driving	High engine rpm under no load	A	
				Driving in low gear for extended time	CO	
				Driving at extremely high speed		
				Powertrain system malfunction		C
				Installed improper size wheels and tires	—	D
				Dragging brakes		
		Improper ignition timing		E		
	Blocked or restricted air flow	Blocked bumper	—		E	
		Blocked radiator grille	Installed car brassiere			
			Mud contamination or paper clogging	—	F	
		Blocked radiator	—			
		Blocked condenser	Blocked air flow		G	
Installed large fog lamp						

A
CO
C
D
E
F
G
H
I
J
K
L
M
N
O
P

PRECAUTION

PRECAUTIONS

Precaution for Supplemental Restraint System (SRS) "AIR BAG" and "SEAT BELT PRE-TENSIONER"

INFOID:000000007795674

The Supplemental Restraint System such as "AIR BAG" and "SEAT BELT PRE-TENSIONER", used along with a front seat belt, helps to reduce the risk or severity of injury to the driver and front passenger for certain types of collision. This system includes seat belt switch inputs and dual stage front air bag modules. The SRS system uses the seat belt switches to determine the front air bag deployment, and may only deploy one front air bag, depending on the severity of a collision and whether the front occupants are belted or unbelted. Information necessary to service the system safely is included in the "SRS AIR BAG" and "SEAT BELT" of this Service Manual.

WARNING:

Always observe the following items for preventing accidental activation.

- To avoid rendering the SRS inoperative, which could increase the risk of personal injury or death in the event of a collision that would result in air bag inflation, all maintenance must be performed by an authorized NISSAN/INFINITI dealer.
- Improper maintenance, including incorrect removal and installation of the SRS, can lead to personal injury caused by unintentional activation of the system. For removal of Spiral Cable and Air Bag Module, see "SRS AIR BAG".
- Never use electrical test equipment on any circuit related to the SRS unless instructed to in this Service Manual. SRS wiring harnesses can be identified by yellow and/or orange harnesses or harness connectors.

PRECAUTIONS WHEN USING POWER TOOLS (AIR OR ELECTRIC) AND HAMMERS

WARNING:

Always observe the following items for preventing accidental activation.

- When working near the Air Bag Diagnosis Sensor Unit or other Air Bag System sensors with the ignition ON or engine running, never use air or electric power tools or strike near the sensor(s) with a hammer. Heavy vibration could activate the sensor(s) and deploy the air bag(s), possibly causing serious injury.
- When using air or electric power tools or hammers, always switch the ignition OFF, disconnect the battery, and wait at least 3 minutes before performing any service.

PREPARATION

< PREPARATION >

[VK50VE]

PREPARATION

PREPARATION

Commercial Service Tools

INFOID:000000007512306

A

CO

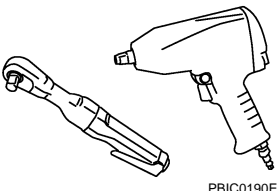
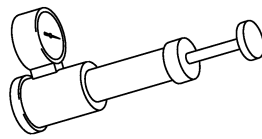
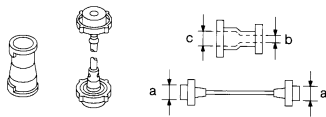
Tool name	Description
<p>Power tool</p>  <p>PBIC0190E</p>	<p>Loosening bolts and nuts</p>
<p>Radiator cap tester</p>  <p>PBIC1982E</p>	<p>Checking radiator and radiator cap</p>
<p>Radiator cap tester adapter</p>  <p>S-NT564</p>	<p>Adapting radiator cap tester to radiator cap and water inlet filler neck a: 28 (1.10) dia. b: 31.4 (1.236) dia. c: 41.3 (1.626) dia. Unit: mm (in)</p>

C

D

E

F

G

H

I

J

K

L

M

N

O

P

PERIODIC MAINTENANCE

ENGINE COOLANT

Inspection

INFOID:000000007512307

LEVEL

- Check if the reservoir tank engine coolant level is within the "MIN" to "MAX" when the engine is cool.

A : MAX

B : MIN

- Adjust the engine coolant level if necessary.

CAUTION:

Refill Genuine NISSAN Long Life Antifreeze/Coolant (blue) or equivalent in its quality mixed with water (distilled or demineralized). Refer to [MA-17, "FOR NORTH AMERICA : Fluids and Lubricants"](#).

- Check that the reservoir tank cap is tightened.

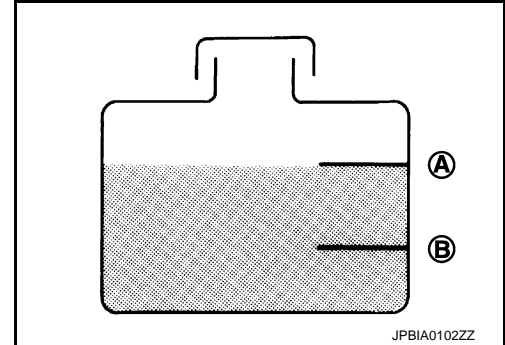

JPBIA0102ZZ

LEAKAGE

- To check for leakage, apply pressure to the cooling system with the radiator cap tester and radiator cap tester adapter (commercial service tool) (A).

Testing pressure : Refer to [CO-51, "Radiator"](#).

WARNING:

Never remove radiator cap when engine is hot. Serious burns could occur from high-pressure engine coolant escaping from water inlet.

CAUTION:

Higher test pressure than specified may cause radiator damage.

NOTE:

In a case that engine coolant decreases, fill radiator with engine coolant.

- If anything is found, repair or replace damaged parts.

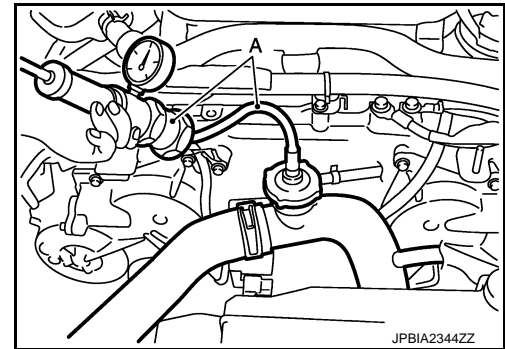

JPBIA2344ZZ

Draining

INFOID:000000007512308

WARNING:

- Never change engine coolant when the engine is hot to avoid being scalded.
- Wrap a thick cloth around radiator cap and carefully remove radiator cap. First, turn radiator cap a quarter of a turn to release built-up pressure. Then turn radiator cap all the way.

- Connect drain hose.

NOTE:

Use general-purpose hose with the dimensions shown in the figure.

A : ϕ 15 - 16 mm (0.59 - 0.63 in)

B : 145 mm (5.71 in)

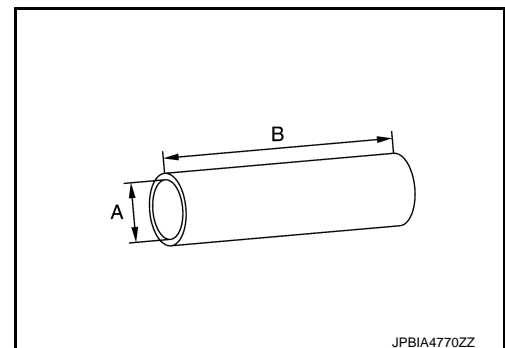

JPBIA4770ZZ

ENGINE COOLANT

[VK50VE]

< PERIODIC MAINTENANCE >

- Open radiator drain plug (2) at the bottom of radiator, and then remove radiator cap.

- 1 : Engine under cover
A : Radiator drain plug hole
⇐ : Vehicle front

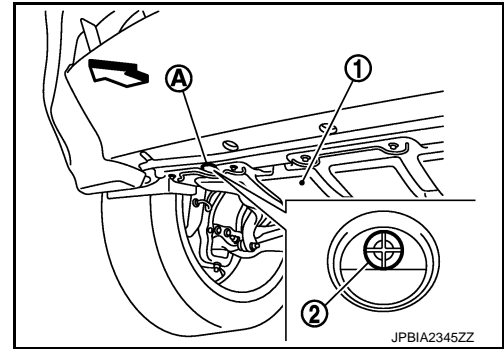

When draining all of engine coolant in the system, open water drain plug on cylinder block. Refer to [EM-204, "Setting"](#).

- Remove reservoir tank if necessary, and drain engine coolant and clean reservoir tank before installing.
- Check drained engine coolant for contaminants such as rust, corrosion or discoloration. If contaminated, flush the engine cooling system. Refer to [CO-37, "Flushing"](#).
- Disconnect drain hose.

Refilling

INFOID:000000007512309

CAUTION:

- Do not reuse O-rings.
- Do not put additive such as waterleak preventive, since it may cause cooling waterway clogging.
- Refill Genuine NISSAN Long Life Antifreeze/Coolant (blue) or equivalent in its quality mixed with water (distilled or demineralized). Refer to [MA-17, "FOR NORTH AMERICA : Fluids and Lubricants"](#).

- Remove engine cover and engine room cover (LH). Refer to [EM-175, "Exploded View"](#).
- Install reservoir tank if removed, and radiator drain plug.

CAUTION:

Be sure to clean drain plug and install with new O-ring.

-  : 1.2 N·m (0.12 kg·m, 11 in·lb)

If water drain plug on cylinder block is removed, close and tighten it. Refer to [EM-258, "Disassembly and Assembly"](#).

- Check that each hose clamp is firmly tightened.
- Remove air relief plug (2) on radiator left side.

- 1 : Reservoir tank
3 : Water inlet
⇐ : Vehicle front

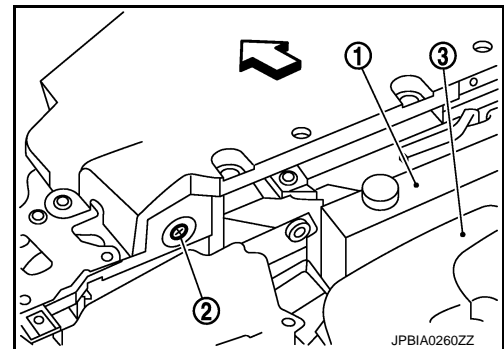

ENGINE COOLANT

[VK50VE]

< PERIODIC MAINTENANCE >

5. Remove air relief plug (1) on heater hose.

↶ : Vehicle front

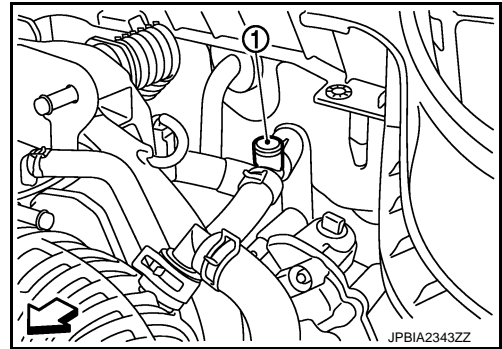

6. Fill water inlet, and reservoir tank if removed, to specified level.
- Pour engine coolant through engine coolant filler neck slowly of less than 2 ℓ (2-1/8 US qt, 1-3/4 Imp qt) a minute to allow air in system to escape.

Engine coolant capacity
(With reservoir tank at
"MAX" level)

: Refer to [CO-51](#),
"[Periodical Maintenance
Specification](#)".

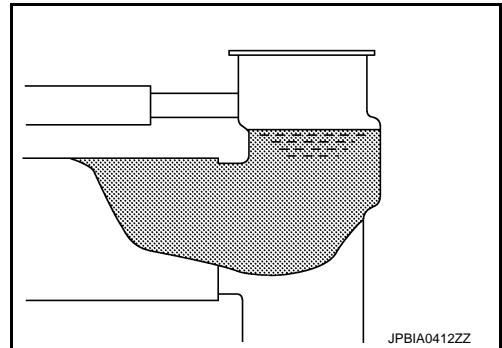

Reservoir tank engine cool-
ant capacity
(At "MAX" level)

: Refer to [CO-51](#),
"[Periodical Maintenance
e Specification](#)".

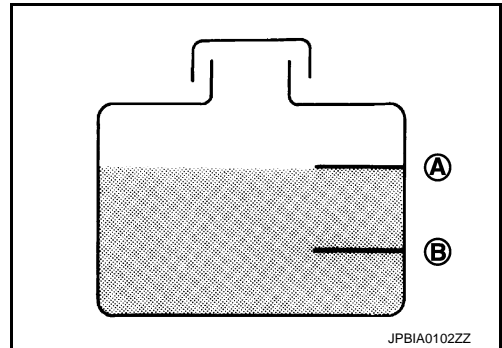

7. When engine coolant overflows air relief hole on radiator, install air relief plug with new O-ring.

CAUTION:
Do not reuse O-rings.

 : 1.2 N·m (0.12 kg·m, 11 in·lb)

8. Repeat step 6.
9. When engine coolant overflows air relief hole on heater hose, install air relief plug with new O-ring. Then refill radiator with engine coolant.

CAUTION:
Do not reuse O-rings.

 : 1.2 N·m (0.12 kg·m, 11 in·lb)

10. Install radiator cap.
11. Warm up engine until opening thermostat. Standard for warming-up time is approximately 10 minutes at 3,000 rpm.
- Check thermostat opening condition by touching radiator hose (lower) to see a flow of warm water.
- CAUTION:**
Watch water temperature gauge so as not to overheat engine.
12. Stop the engine and cool down to less than approximately 50°C (122°F).
- Cool down using fan to reduce the time.
 - If necessary, refill radiator up to filler neck with engine coolant.

ENGINE COOLANT

[VK50VE]

< PERIODIC MAINTENANCE >

13. Refill reservoir tank to "MAX" level line with engine coolant.
14. Repeat steps 10 through 13 two or more times with radiator cap installed until engine coolant level no longer drops.
15. Check cooling system for leakage with engine running.
16. Warm up the engine, and check for sound of engine coolant flow while running engine from idle up to 3,000 rpm with heater temperature controller set at several position between "COOL" and "WARM".
 - Sound may be heard from the heater unit.
17. Repeat step 16 three times.
18. If sound is heard, bleed air from cooling system by repeating step 6, and steps from 10 to 17 until engine coolant level no longer drops.
19. Check that the reservoir tank cap is tightened.

Flushing

INFOID:000000007512310

1. Install reservoir tank if removed, and radiator drain plug.
CAUTION:
Be sure to clean drain plug and install with new O-ring.

 : 1.2 N·m (0.12 kg·m, 11 in·lb)

If water drain plug on cylinder block is removed, close and tighten it. Refer to [EM-258, "Disassembly and Assembly"](#).

2. Remove air relief plug (1) on heater hose.

 : Vehicle front

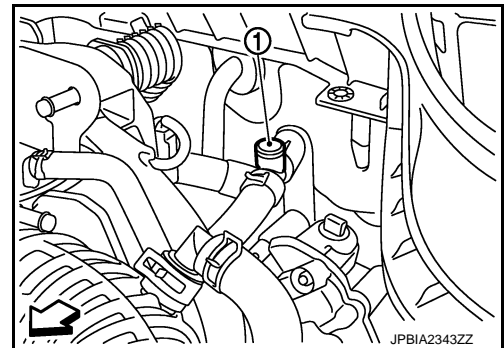

3. Remove air relief plug (2) on radiator.

1 : Reservoir tank

3 : Water inlet

 : Vehicle front

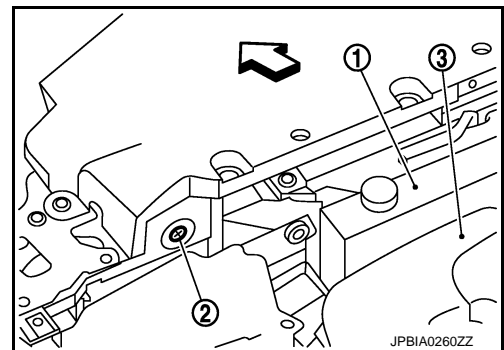

4. Fill water inlet with water until water spills from the air relief holes, then close air relief plugs. Fill water inlet and reservoir tank with water and reinstall radiator cap.

 : 1.2 N·m (0.12 kg·m, 11 in·lb)

5. Run the engine and warm it up to normal operating temperature.
6. Rev the engine two or three times under no-load.
7. Stop the engine and wait until it cools down.
8. Drain water from the system. Refer to [CO-34, "Draining"](#).
9. Repeat steps 1 through 8 until clear water begins to drain from radiator.
10. Check that the reservoir tank cap is tightened.

RADIATOR RADIATOR CAP

RADIATOR CAP : Inspection

INFOID:000000007512311

- Check valve seat of radiator cap.
- Check if valve seat (A) is swollen to the extent that the edge of the metal plunger (B) cannot be seen when watching it vertically from the top.
- Check if valve seat has no soil and damage.

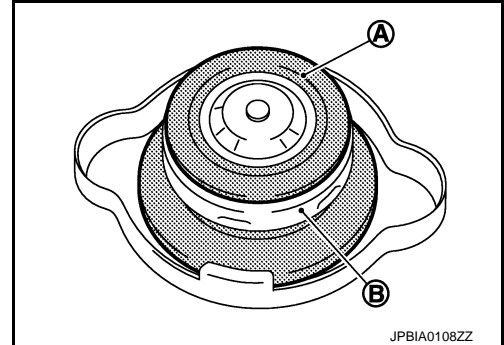

- Pull negative-pressure valve to open it, and check that it close completely when released.
- Check that there is no dirt or damage on the valve seat of radiator cap negative-pressure valve.
- Check that there are no unusualness in the opening and closing conditions of negative-pressure valve.

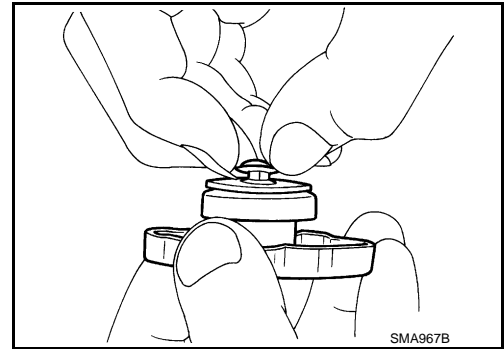

- Check radiator cap relief pressure.
- When connecting radiator cap to the radiator cap tester (commercial service tool) and the radiator cap tester adapter (commercial service tool) (A), apply engine coolant to the cap seal surface.

Standard and limit : Refer to [CO-51, "Radiator"](#).

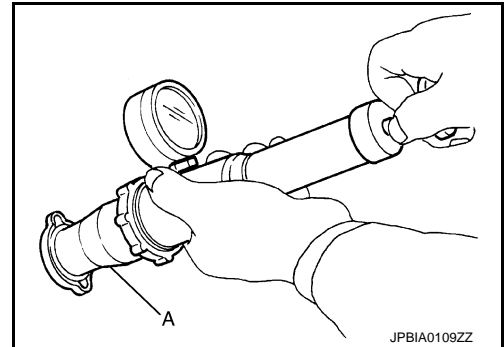

- Replace radiator cap if there is an unusualness related to the above three.

CAUTION:

When installing radiator cap, thoroughly wipe out the water inlet filler neck to remove any waxy residue or foreign material.

RADIATOR

RADIATOR : Inspection

INFOID:000000007512312

Check radiator for mud or clogging. If necessary, clean radiator as per the following:

- Be careful not to bend or damage radiator fins.
 - When radiator is cleaned without removal, remove all surrounding parts such as radiator cooling fan assembly and horns. Then tape harness and connectors to prevent water from entering.
1. Apply water by hose to the back side of the radiator core vertically downward.
 2. Apply water again to all radiator core surfaces once per minute.

RADIATOR

[VK50VE]

< PERIODIC MAINTENANCE >

3. Stop washing if any stains no longer flow out from radiator.
4. Blow air into the back side of radiator core vertically downward.
 - Use compressed air lower than 490 kPa (5 kg/cm², 71 psi) and keep distance more than 30 cm (11.8 in).
5. Blow air again into all the radiator core surfaces once per minute until no water sprays out.

A

CO

C

D

E

F

G

H

I

J

K

L

M

N

O

P

RADIATOR

< REMOVAL AND INSTALLATION >

[VK50VE]

REMOVAL AND INSTALLATION

RADIATOR

Exploded View

INFOID:000000007512313

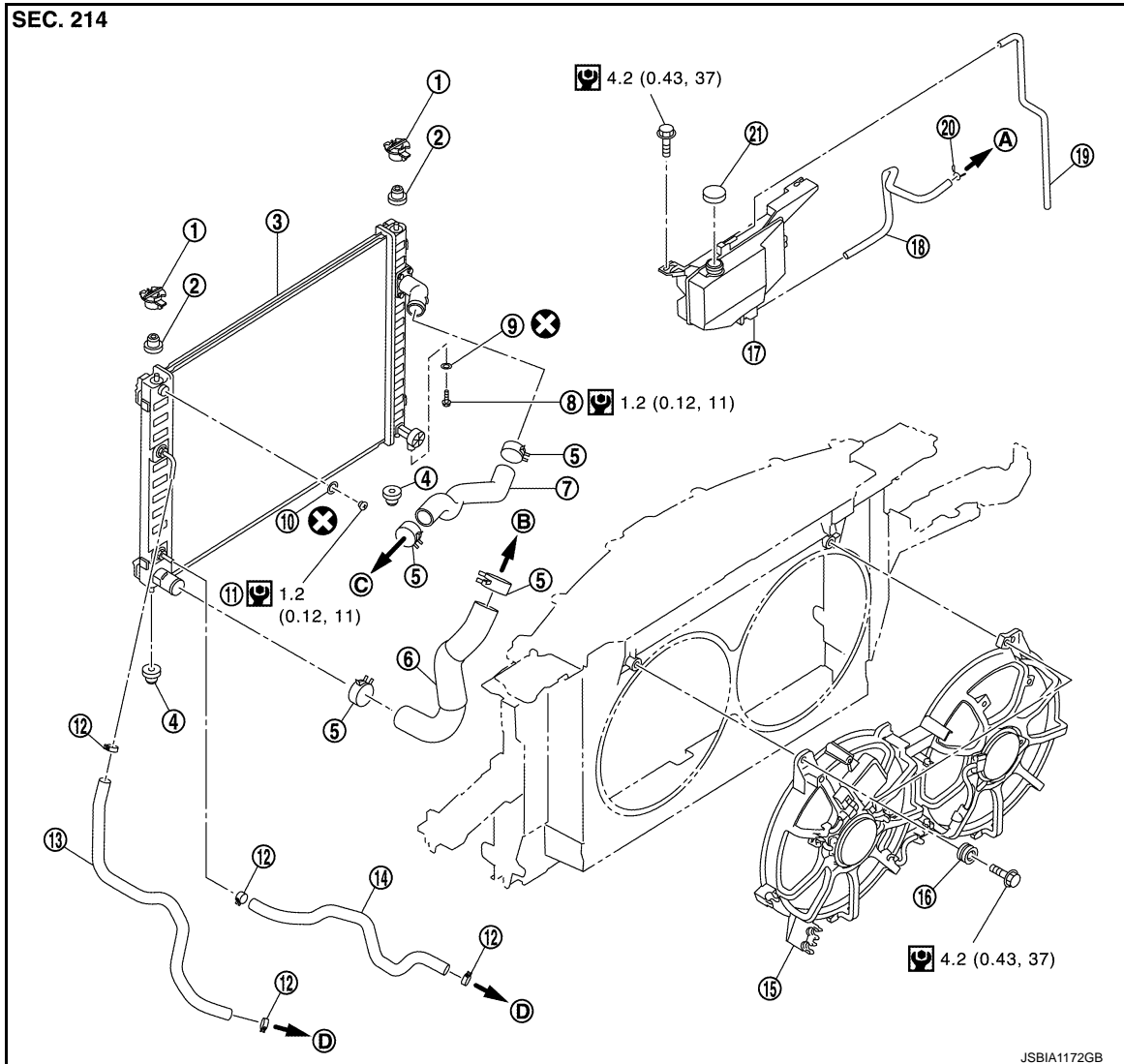

- | | | |
|-----------------------------|----------------------------|----------------------------|
| 1. Upper mount bracket | 2. Mounting rubber (upper) | 3. Radiator |
| 4. Mounting rubber (lower) | 5. Clamp | 6. Radiator hose (lower) |
| 7. Radiator hose (upper) | 8. Drain plug | 9. O-ring |
| 10. O-ring | 11. Air relief plug | 12. Clamp |
| 13. A/T fluid cooler hose | 14. A/T fluid cooler hose | 15. Cooling fan assembly |
| 16. Grommet | 17. Reservoir tank | 18. Reservoir tank hose |
| 19. Reservoir tank hose | 20. Clamp | 21. Reservoir tank cap |
| A. To water outlet (front) | B. To water inlet | C. To water outlet (front) |
| D. To A/T fluid cooler pipe | | |

Refer to [GI-4, "Components"](#) for symbols in the figure.

Removal and Installation

INFOID:000000007512314

REMOVAL

WARNING:

RADIATOR

< REMOVAL AND INSTALLATION >

[VK50VE]

Never remove radiator cap when engine is hot. Serious burns could occur from high-pressure engine coolant escaping from water inlet. Wrap a thick cloth around the cap. Slowly turn it a quarter of a turn to release built-up pressure. Carefully remove radiator cap by turning it all the way.

1. Remove the following parts:
 - Engine under cover, using a power tool.
 - Engine cover and engine room cover (RH and LH): Refer to [EM-175, "Exploded View"](#).
 - Air cleaner case: Refer to [EM-178, "Exploded View"](#).
 - Air duct (inlet): Refer to [EM-178, "Exploded View"](#).
 - Hood lock stay assembly and horn: Refer to [DLK-291, "Exploded View"](#) and [HRN-4, "Exploded View"](#).
2. Remove condenser. Refer to [HA-107, "Exploded View"](#).
3. Drain engine coolant from radiator. Refer to [CO-34, "Draining"](#).

CAUTION:

- Perform this step when the engine is cold.
- Never spill engine coolant on drive belts.

4. Disconnect A/T fluid cooler hoses from radiator.
 - Install blind plug to avoid leakage of A/T fluid.
5. Remove radiator hoses (upper and lower) and reservoir tank hose.

CAUTION:

- Be careful not to allow engine coolant to contact drive belts.
- Never loosen radiator water inlet pipe mounting screw (A). If loosened, replace radiator (1).

2 : Radiator water inlet pipe

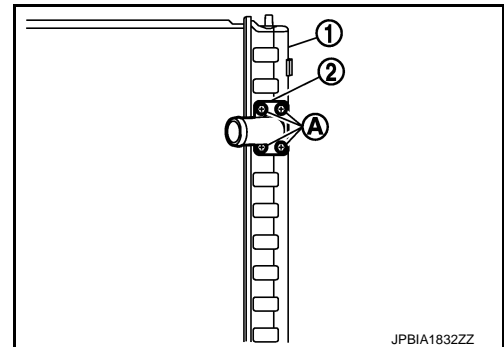

6. Rotate two radiator upper mount brackets 90 degrees in direction as shown in the figure, and remove them.

1 : Radiator upper mount bracket

A : Turn 90° counterclockwise

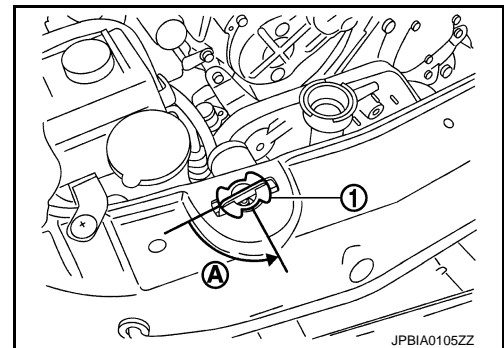

7. Remove radiator as per the following:

CAUTION:

Be careful not to damage radiator core.

- a. Lift up and pull the radiator (1) forward, and then remove the mounting rubber (lower) (3) from the radiator core support (2).

← : Vehicle front

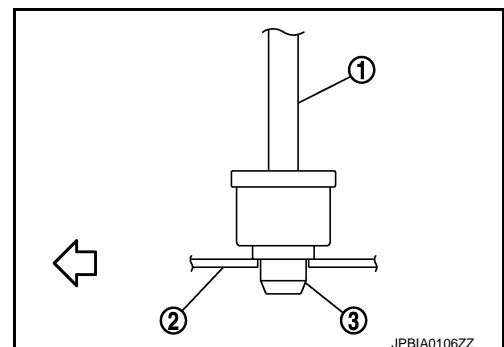

RADIATOR

< REMOVAL AND INSTALLATION >

[VK50VE]

b. Remove radiator (1) from front of radiator core support (2).

↶ : Vehicle front

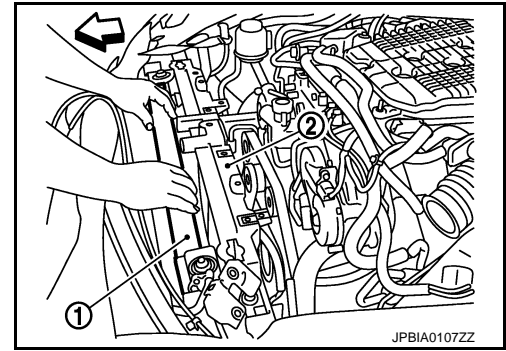

INSTALLATION

Note the following, and install in the reverse order of removal.

CAUTION:

- Do not reuse O-rings.
- Use genuine mounting bolts for the cooling fan assembly and strictly observe the tightening torque. (Breakage prevention for radiator)

NOTE:

- Insert the radiator hose (1) all the way to the stopper (2) or by 33 mm (1.30 in) (hose without a stopper).

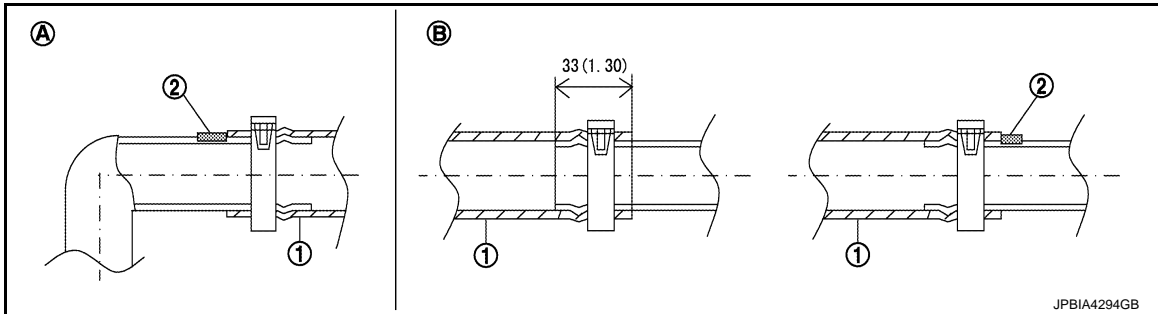

Unit mm (in)

A. Radiator side

B. Engine side

- For the orientation of the hose clamp pawl, refer to the figure.

Radiator hose	Hose end	Paint mark	Position of hose clamp*
Radiator hose (upper)	Radiator side	Upper	A
	Engine side	Upper	B
Radiator hose (lower)	Radiator side	Lower	C
	Engine side	Front side	D

*Refer to the illustrations for the specific position each hose clamp tab.

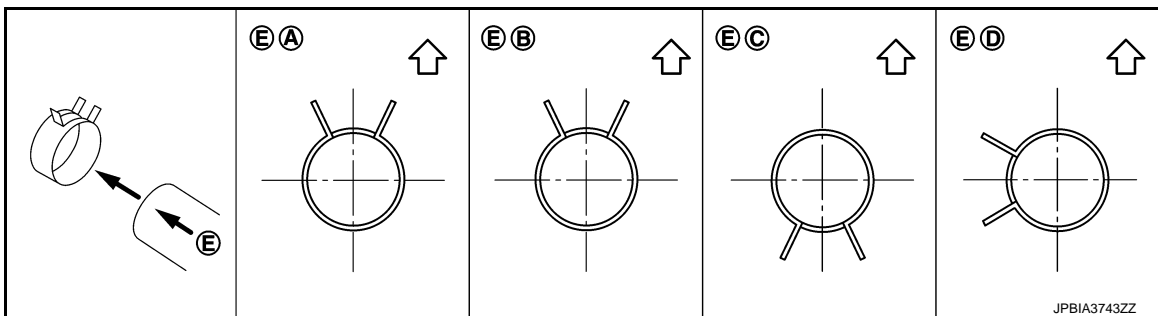

↶ Vehicle upper

RADIATOR

[VK50VE]

< REMOVAL AND INSTALLATION >

- The angle (b) created by the hose clamp pawl and the specified line (A) must be within $\pm 30^\circ$ as shown in the figure.

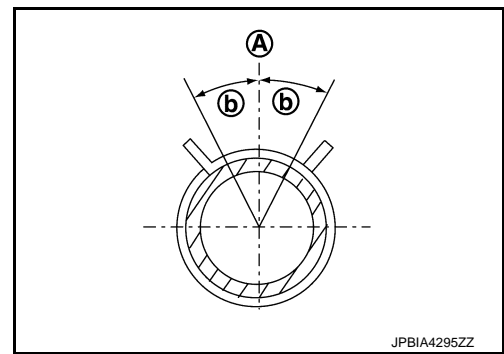

- To install hose clamps (1), check that the dimension (A) from the end of the paint mark (2) on the radiator hose to the hose clamp is within the reference value.

Dimension "A" : (-1) – (+1) mm
(-0.04) – (+0.04) in

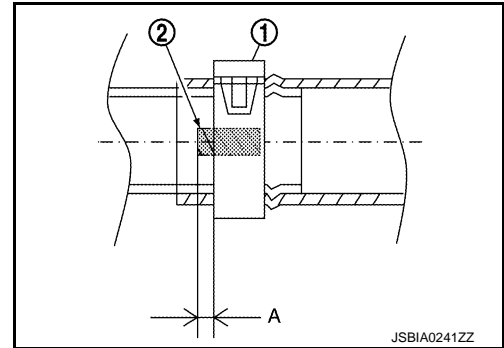

Inspection

INFOID:000000007512315

INSPECTION AFTER INSTALLATION

- Check for leakage of engine coolant using the radiator cap tester adapter (commercial service tool) and the radiator cap tester (commercial service tool). Refer to [CO-34. "Inspection"](#).
- Start and warm up the engine. Visually check that there is no leakage of engine coolant and A/T fluid.

COOLING FAN

< REMOVAL AND INSTALLATION >

[VK50VE]

COOLING FAN

Exploded View

INFOID:000000007512316

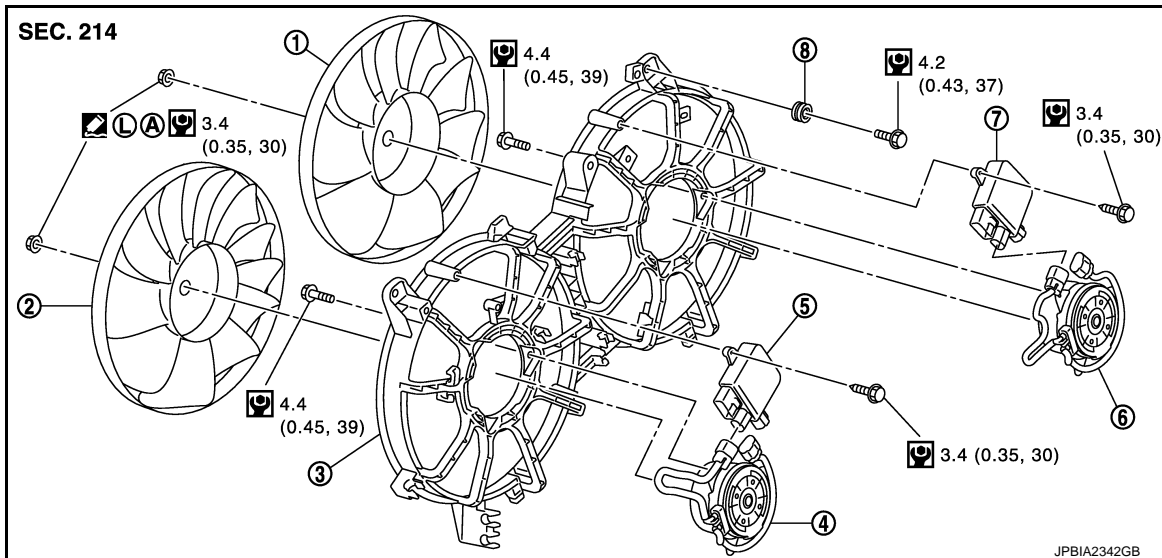

- | | | |
|-------------------------------|-------------------------------|-------------------|
| 1. Cooling fan (RH) | 2. Cooling fan (LH) | 3. Fan shroud |
| 4. Fan motor (LH) | 5. Cooling fan control module | 6. Fan motor (RH) |
| 7. Cooling fan control module | 8. Grommet | |
- A. Apply on fan motor shaft

Apply high strength thread locking sealant or equivalent.

Refer to [GI-4, "Components"](#) for symbols not described on the above.

Removal and Installation

INFOID:000000007512317

REMOVAL

1. Drain engine coolant. Refer to [CO-34, "Draining"](#).
2. Remove reservoir tank. Refer to [CO-40, "Exploded View"](#).
3. Remove air cleaner case. Refer to [EM-178, "Exploded View"](#).
4. Remove mounting bolt from high pressure flexible hose bracket. Refer to [HA-99, "Exploded View"](#).
5. Remove radiator hose (upper). Refer to [CO-40, "Exploded View"](#).
6. Disconnect harness connector from cooling fan control modules, and move harness to aside.
7. Remove cooling fan assembly.

CAUTION:

Be careful not to damage or scratch on radiator core.

INSTALLATION

Note the following, and install in the reverse order of removal.

CAUTION:

Only use genuine parts for cooling fan mounting bolt and observe the specified torque (to prevent radiator from being damaged).

Disassembly and Assembly

INFOID:000000007512318

DISASSEMBLY

1. Disconnect harness connector from cooling fan control modules.
2. Remove cooling fan control modules from cooling fan assembly.

CAUTION:

Handle carefully to avoid dropping and impact.

COOLING FAN

[VK50VE]

< REMOVAL AND INSTALLATION >

3. Remove cooling fan mounting nuts, and then remove the cooling fan (RH and LH).
4. Remove fan motors (RH and LH).

ASSEMBLY

Note the following, and assemble in the reverse order of disassembly.

CAUTION:

RH and LH cooling fans are different. Be careful not to misassemble them.

- Install each fan in the following position.

Right side : 9 blades

Left side : 11 blades

- Secure the harness tightly to the fan shroud to prevent the fan rotation area from being slack.

Inspection

INFOID:000000007512319

INSPECTION AFTER REMOVAL

Check that fan motors operate normally.

NOTE:

Cooling fans are controlled by cooling fan control module. For details, refer to [EC-657, "System Description"](#).

INSPECTION AFTER DISASSEMBLY

Cooling Fan

Inspect cooling fan for crack or unusual bend.

- If anything is found, replace cooling fan.

A

CO

C

D

E

F

G

H

I

J

K

L

M

N

O

P

WATER PUMP

< REMOVAL AND INSTALLATION >

[VK50VE]

WATER PUMP

Exploded View

INFOID:000000007512320

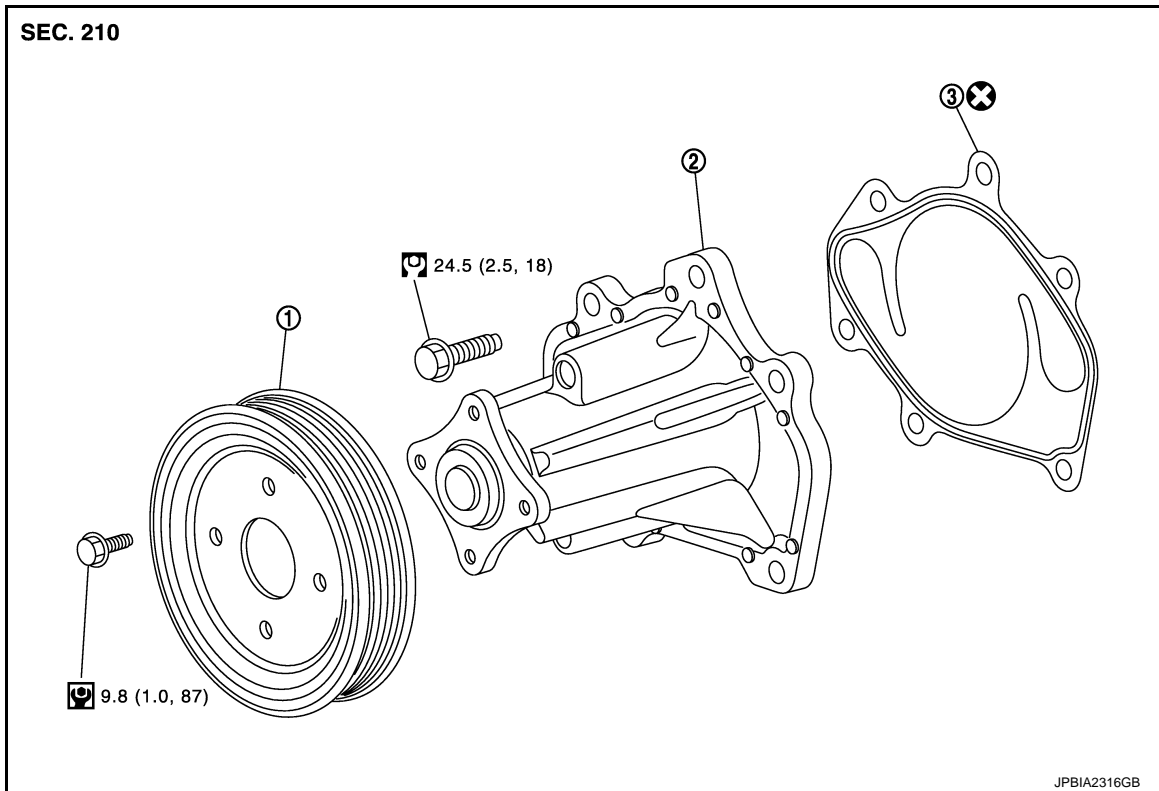

1. Water pump pulley

2. Water pump

3. Gasket

Refer to [GI-4, "Components"](#) for symbols in the figure.

Removal and Installation

INFOID:000000007512321

CAUTION:

- When removing water pump assembly, be careful not to get engine coolant on drive belts.
- Water pump cannot be disassembled and should be replaced as a unit.
- After installing water pump, connect hose and clamp securely, then check for leakage using the radiator cap tester (commercial service tool) and the radiator cap tester adapter (commercial service tool).

REMOVAL

1. Remove following parts:
 - Engine undercover, using a power tool.
 - Engine cover and engine room cover (RH and LH). Refer to [EM-175, "Exploded View"](#).
 - Air duct (inlet): Refer to [EM-178, "Exploded View"](#).
 - Reservoir tank. Refer to [CO-40, "Exploded View"](#).
2. Loosen water pump pulley mounting bolts.
3. Remove alternator, water pump and A/C compressor belt: Refer to [EM-165, "Removal and Installation"](#).
4. Remove water pump pulley.
5. Drain engine coolant from drain plugs on radiator and cylinder block. Refer to [CO-34, "Draining"](#) and [EM-204, "Setting"](#).

CAUTION:

- Perform this step when engine is cold.
 - Never spill engine coolant on drive belt.
6. Remove water pump. Refer to [CO-46, "Exploded View"](#).
 - Engine coolant will leak from cylinder block, so have a receptacle ready under vehicle.

WATER PUMP

< REMOVAL AND INSTALLATION >

[VK50VE]

CAUTION:

- Handle the water pump vane so that it does not contact any other parts.
- Never disassemble water pump.

INSTALLATION

Install in the reverse order of removal.

Inspection

INFOID:000000007512322

INSPECTION AFTER REMOVAL

- Visually check that there is no significant dirt or rusting on water pump body and vane (A).
- Check there is no slack in vane shaft, and that it turns smoothly when rotated by hand.
- If anything is found, replace water pump.

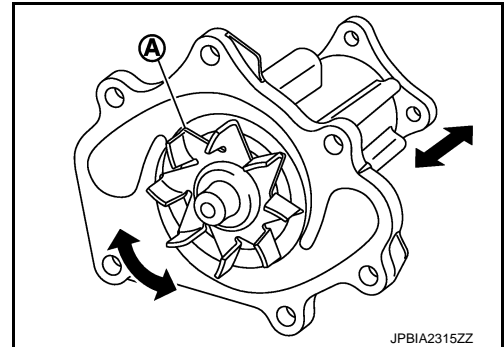

INSPECTION AFTER INSTALLATION

- Check that the reservoir tank cap is tightened.
- Check for leakage of engine coolant using the radiator cap tester adapter (commercial service tool) and the radiator cap tester (commercial service tool). Refer to [CO-34. "Inspection"](#).
- Start and warm up the engine. Visually check that there is no leakage of engine coolant.

A
CO
C
D
E
F
G
H
I
J
K
L
M
N
O
P

WATER INLET AND THERMOSTAT ASSEMBLY

< REMOVAL AND INSTALLATION >

[VK50VE]

WATER INLET AND THERMOSTAT ASSEMBLY

Exploded View

INFOID:000000007512323

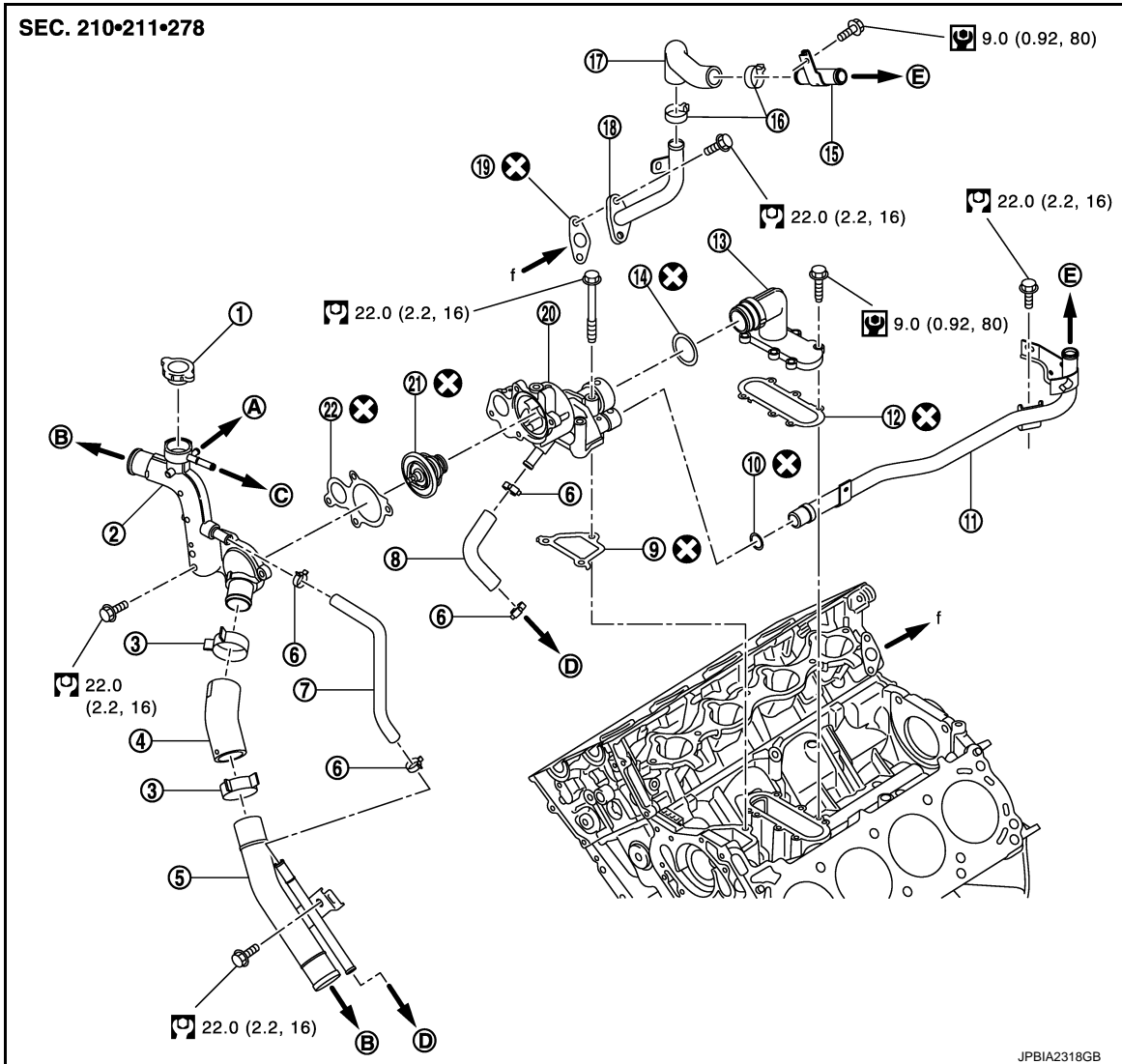

- | | | |
|-----------------------|------------------------|----------------|
| 1. Radiator cap | 2. Water inlet | 3. Clamp |
| 4. Water suction hose | 5. Water suction pipe | 6. Clamp |
| 7. Water hose | 8. Water hose | 9. Gasket |
| 10. O-ring | 11. Heater pipe | 12. Gasket |
| 13. Water connector | 14. O-ring | 15. Water pipe |
| 16. Clamp | 17. Water hose | 18. Water pipe |
| 19. Gasket | 20. Thermostat housing | 21. Thermostat |
| 22. Gasket | | |
- A. To electric throttle control actuator B. To radiator C. To reservoir tank
D. To oil cooler E. To heater

Refer to [GI-4, "Components"](#) for symbols in the figure.

Removal and Installation

INFOID:000000007512324

REMOVAL

1. Remove engine cover and engine room cover (RH and LH). Refer to [EM-175, "Exploded View"](#).

WATER INLET AND THERMOSTAT ASSEMBLY

[VK50VE]

< REMOVAL AND INSTALLATION >

2. Remove air duct (inlet). Refer to [EM-178, "Exploded View"](#).
3. Remove reservoir tank. Refer to [CO-40, "Exploded View"](#).
4. Remove engine undercover with a power tool.
5. Drain engine coolant from drain plugs on radiator and cylinder block. Refer to [CO-34, "Draining"](#) and [EM-204, "Setting"](#).

CAUTION:

- Perform this step when engine is cold.
- Never spill engine coolant on drive belts.

6. Disconnect radiator hose (upper and lower). Refer to [CO-40, "Exploded View"](#).
7. Remove intake manifold. Refer to [EM-180, "Exploded View"](#).
8. Remove water suction pipe and water suction hose.
9. Remove water inlet and thermostat.
10. Remove water connector, heater pipes and heater hoses.
11. Remove thermostat housing.

INSTALLATION

Note the following, and install in the reverse order of removal.

CAUTION:

- Do not reuse O-rings.
- Be careful not to spill engine coolant over engine room. Use rag to absorb engine coolant.

Thermostat

- Install thermostat with the whole circumference of each flange part (A) fit securely inside rubber ring (1).

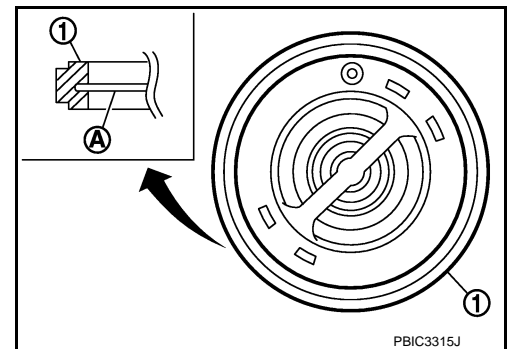

- Install thermostat with jiggle valve (A) facing upwards. The position deviation may be within the range of 20 degrees (b).

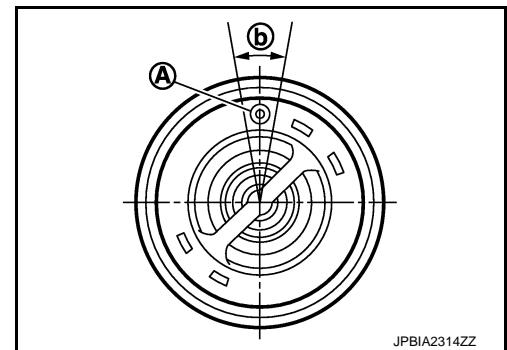

Water Connector and Heater Pipe

- First apply a neutral detergent to O-rings, then quickly insert the insertion parts of the water connector and heater pipe into the installation holes.

Inspection

INFOID:000000007512325

INSPECTION AFTER REMOVAL

- Check that valve in thermostat is completely closing at normal temperature.

WATER INLET AND THERMOSTAT ASSEMBLY

[VK50VE]

< REMOVAL AND INSTALLATION >

- Place a thread (A) so that it is caught in the valve of the thermostat. Immerse fully in a container filled with water. Heat while stirring.
- The valve opening temperature is the temperature at which the valve opens and falls from the thread.
- After checking the maximum valve lift, lower the water temperature and check the valve closing temperature.

Thermostat (Standard) : Refer to [CO-51, "Thermostat"](#).

- If the malfunctioning condition, when valve seating at ordinary room temperature, or measured values are out of the standard, replace thermostat.

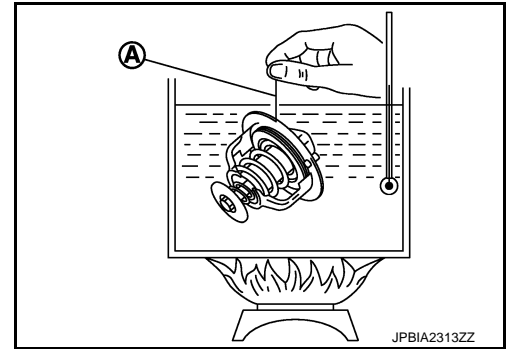

INSPECTION AFTER INSTALLATION

- Check that the reservoir tank cap is tightened.
- Check for leakage of engine coolant using the radiator cap tester adapter (commercial service tool) and the radiator cap tester (commercial service tool). Refer to [CO-34, "Inspection"](#).
- Start and warm up the engine. Visually check that there is no leakage of engine coolant.

SERVICE DATA AND SPECIFICATIONS (SDS)

< SERVICE DATA AND SPECIFICATIONS (SDS)

[VK50VE]

SERVICE DATA AND SPECIFICATIONS (SDS)

SERVICE DATA AND SPECIFICATIONS (SDS)

Periodical Maintenance Specification

INFOID:0000000007512326

ENGINE COOLANT CAPACITY (APPROXIMATELY)

Unit: ℓ (US qt, Imp qt)

Engine coolant capacity [With reservoir tank ("MAX" level)]	11 (11-5/8, 9-5/8)
Reservoir tank engine coolant capacity (At "MAX" level)	0.8 (7/8, 3/4)

Radiator

INFOID:0000000007512327

Unit: kPa (kg/cm², psi)

Cap relief pressure	Standard	122.3 - 151.7 (1.2 - 1.5, 18 - 22)
	Limit	107 (1.1, 16)
Leakage testing pressure		157 (1.6, 23)

Thermostat

INFOID:0000000007512328

Thermostat	Standard
Valve opening temperature	82°C (180°F)
Maximum valve lift	10.0 mm/95°C (0.394 in/203°F)
Valve closing temperature	77°C (171°F)

A
CO
C
D
E
F
G
H
I
J
K
L
M
N
O
P