

SECTION STR

STARTING SYSTEM

CONTENTS

BASIC INSPECTION	2	PRECAUTION	12	A
DIAGNOSIS AND REPAIR WORK FLOW	2	PRECAUTIONS	12	STR
Work Flow	2	Precaution for Supplemental Restraint System (SRS) "AIR BAG" and "SEAT BELT PRE-TENSIONER"	12	C
SYSTEM DESCRIPTION	5	Precaution for Procedure without Cowl Top Cover...12		D
STARTING SYSTEM	5	Precautions For Xenon Headlamp Service	12	E
System Diagram	5	PREPARATION	14	F
System Description	5	PREPARATION	14	G
VQ35HR	5	Special Service Tools	14	H
VQ35HR : Component Parts Location	6	Commercial Service Tools	14	I
VK50VE	6	REMOVAL AND INSTALLATION	15	J
VK50VE : Component Parts Location	7	STARTER MOTOR	15	K
Component Description	7	VQ35HR	15	L
DTC/CIRCUIT DIAGNOSIS	8	VQ35HR : Exploded View	15	M
B TERMINAL CIRCUIT	8	VQ35HR : Removal and Installation (2WD)	16	N
Description	8	VQ35HR : Removal and Installation (AWD)	17	O
Diagnosis Procedure	8	VQ35HR : Inspection	18	P
S CONNECTOR CIRCUIT	9	VK50VE	18	
Description	9	VK50VE : Exploded View	18	
Diagnosis Procedure	9	VK50VE : Removal and Installation	20	
STARTING SYSTEM	10	VK50VE : Inspection	20	
Wiring Diagram - STARTING SYSTEM -	10	SERVICE DATA AND SPECIFICATIONS (SDS)	21	
SYMPTOM DIAGNOSIS	11	SERVICE DATA AND SPECIFICATIONS (SDS)	21	
STARTING SYSTEM	11	Starter Motor	21	
Symptom Table	11			

DIAGNOSIS AND REPAIR WORK FLOW

< BASIC INSPECTION >

BASIC INSPECTION

DIAGNOSIS AND REPAIR WORK FLOW

Work Flow

INFOID:000000007519288

OVERALL SEQUENCE

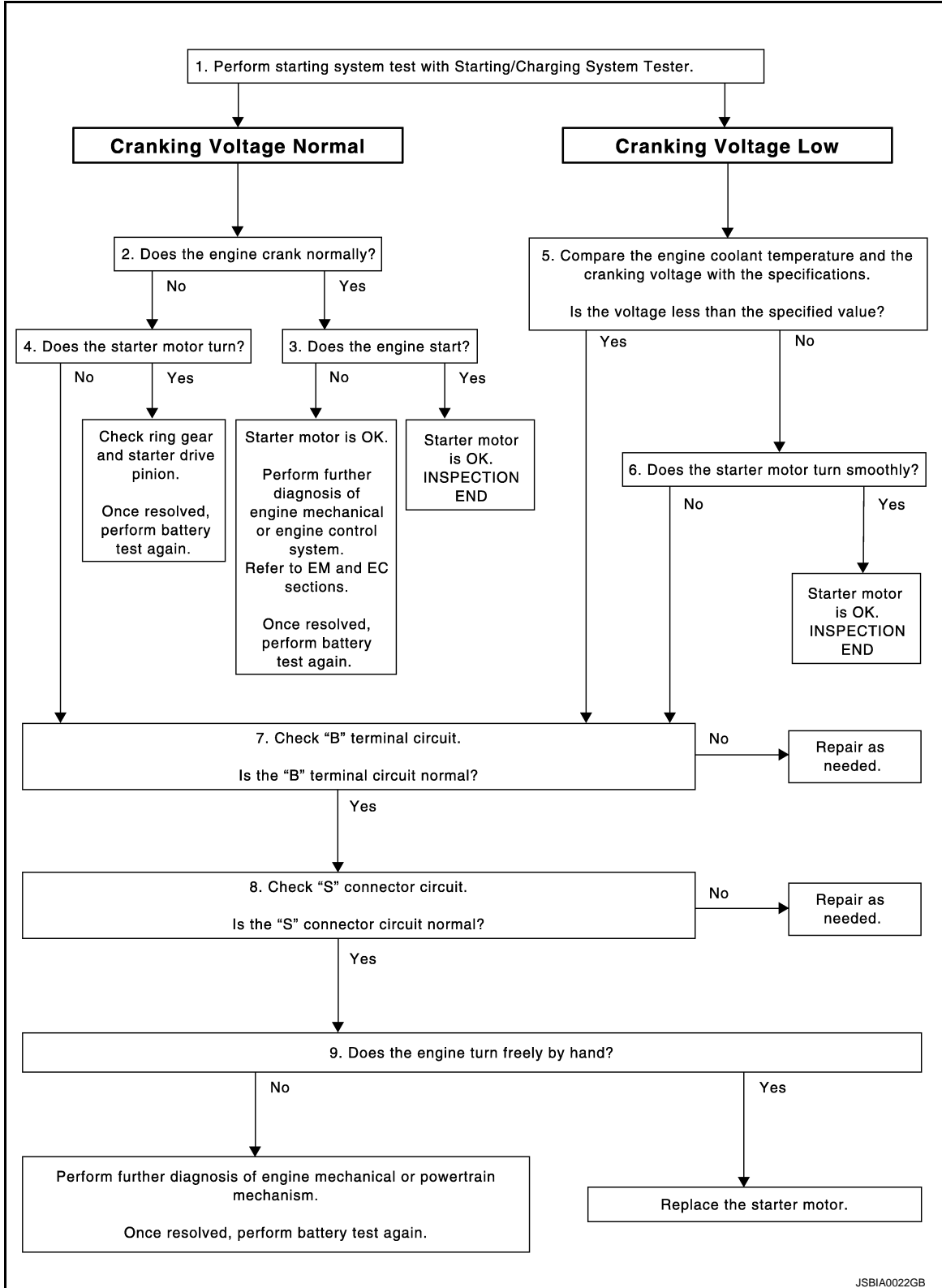

JSBIA0022GB

DETAILED FLOW

DIAGNOSIS AND REPAIR WORK FLOW

< BASIC INSPECTION >

NOTE:

To ensure a complete and thorough diagnosis, the battery, starter motor and alternator test segments must be done as a set from start to finish.

1. DIAGNOSIS WITH STARTING/CHARGING SYSTEM TESTER

Perform the starting system test with Starting/Charging System Tester (SST: J-44373). For details and operating instructions, refer to Technical Service Bulletin.

Test result

CRANKING VOLTAGE NORMAL>>GO TO 2.

CRANKING VOLTAGE LOW>>GO TO 5.

CHARGE BATTERY>>Perform the slow battery charging procedure. (Initial rate of charge is 10A for 12 hours.) Perform battery test again. Refer to Technical Service Bulletin.

REPLACE BATTERY>>Before replacing battery, clean the battery cable clamps and battery posts. Perform battery test again. Refer to Technical Service Bulletin. If second test result is "REPLACE BATTERY", then do so. Perform battery test again to confirm repair.

2. CRANKING CHECK

Check that the starter motor operates correctly.

Does the engine crank normally?

YES >> GO TO 3.

NO >> GO TO 4.

3. ENGINE START CHECK

Check that the engine starts.

Does the engine start?

YES >> Starter motor is OK. INSPECTION END

NO >> Perform further diagnosis of engine mechanical or engine control system. Refer EM and EC sections. Once resolved, perform battery test again.

4. STARTER MOTOR ACTIVATION

Check that the starter motor operates.

Does the starter motor turn?

YES >> Check ring gear and starter motor drive pinion. Once resolved, perform battery test again.

NO >> GO TO 7.

5. COMPARISON BETWEEN ENGINE COOLANT AND CRANKING VOLTAGE

Compare the engine coolant temperature and the cranking voltage with the specifications.

Minimum Specification of Cranking Voltage Referencing Coolant Temperature

Engine coolant temperature [°C (°F)]	Voltage [V]
-30 to -20 (-22 to -4)	8.6
-19 to -10 (-2 to 14)	9.1
-9 to 0 (16 to 32)	9.5
More than 1 (More than 34)	9.9

Is the voltage less than the specified value?

YES >> GO TO 7.

NO >> GO TO 6.

6. STARTER OPERATION

Check the starter operation status.

Does the starter motor turn smoothly?

YES >> Starter motor is OK. INSPECTION END

NO >> GO TO 7.

7. "B" TERMINAL CIRCUIT INSPECTION

Check "B" terminal circuit. Refer to [STR-8, "Diagnosis Procedure"](#).

Is "B" terminal circuit normal?

A

STR

C

D

E

F

G

H

I

J

K

L

M

N

O

P

DIAGNOSIS AND REPAIR WORK FLOW

< BASIC INSPECTION >

- YES >> GO TO 8.
- NO >> Repair as needed.

8. "S" CONNECTOR CIRCUIT INSPECTION

Check "S" connector circuit. Refer to [STR-9. "Diagnosis Procedure"](#).

Is "S" connector circuit normal?

- YES >> GO TO 9.
- NO >> Repair as needed.

9. ENGINE ROTATION STATUS

Check that the engine can be rotated by hand.

Does the engine turn freely by hand?

- YES >> Replace starter motor.
- NO >> Perform further diagnosis of engine mechanical or powertrain mechanism. Once resolved, perform battery test again. Refer to Technical Service Bulletin.

STARTING SYSTEM

< SYSTEM DESCRIPTION >

SYSTEM DESCRIPTION

STARTING SYSTEM

System Diagram

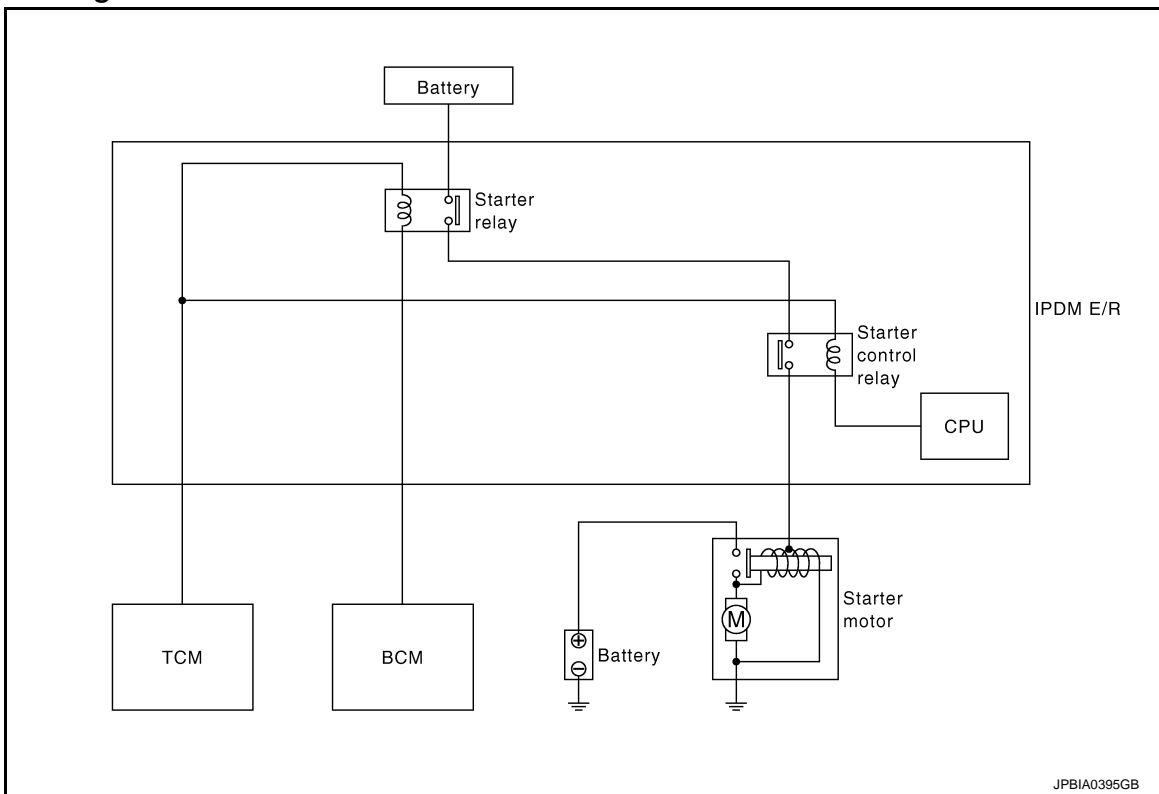

System Description

The starter motor plunger closes and provides a closed circuit between the battery and starter motor. The starter motor is grounded to the engine block. With power and ground supplied, cranking occurs and the engine starts.

VQ35HR

A

STR

C

D

E

F

G

H

I

J

K

L

M

N

O

P

STARTING SYSTEM

< SYSTEM DESCRIPTION >

VQ35HR : Component Parts Location

INFOID:000000007519291

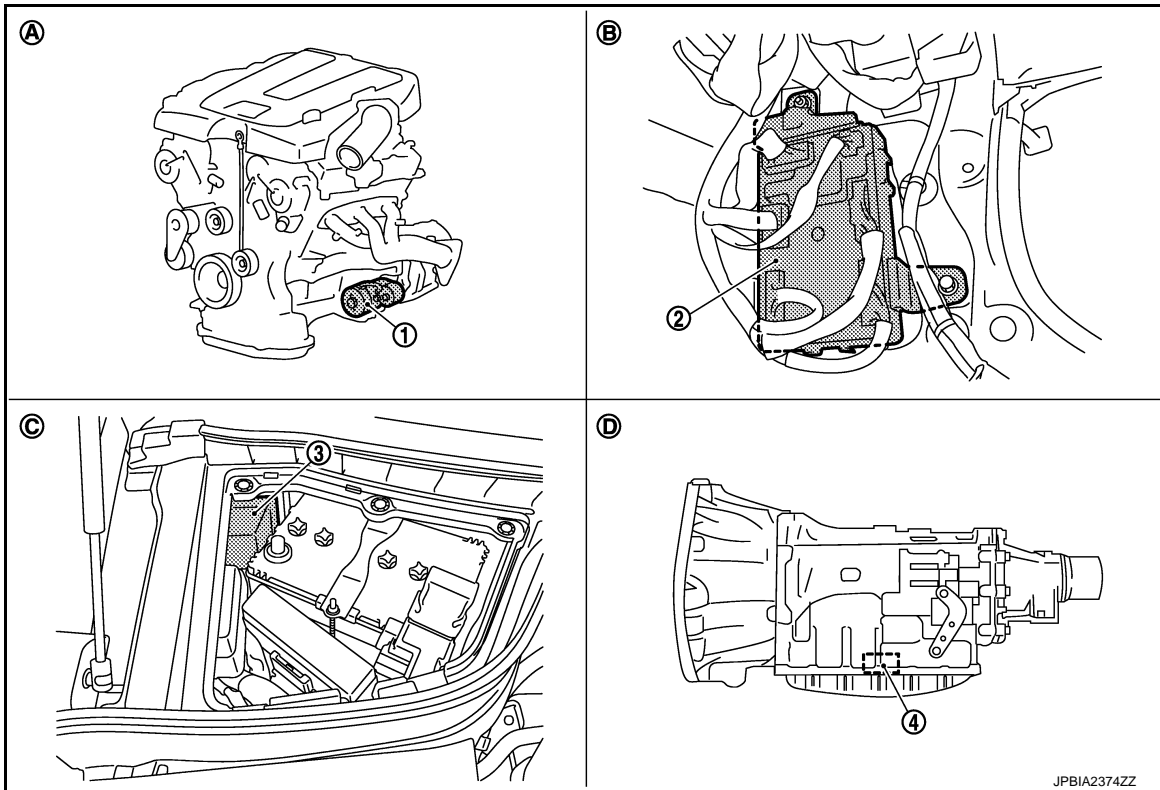

1. Starter motor

2. BCM

3. IPDM E/R

4. TCM

A. Cylinder block (bank 2) side

B. Dash side lower (Passenger side)

C. Engine room dash panel (RH)

D. Inside of A/T (built into A/T)

VK50VE

STARTING SYSTEM

< SYSTEM DESCRIPTION >

VK50VE : Component Parts Location

INFOID:000000007519292

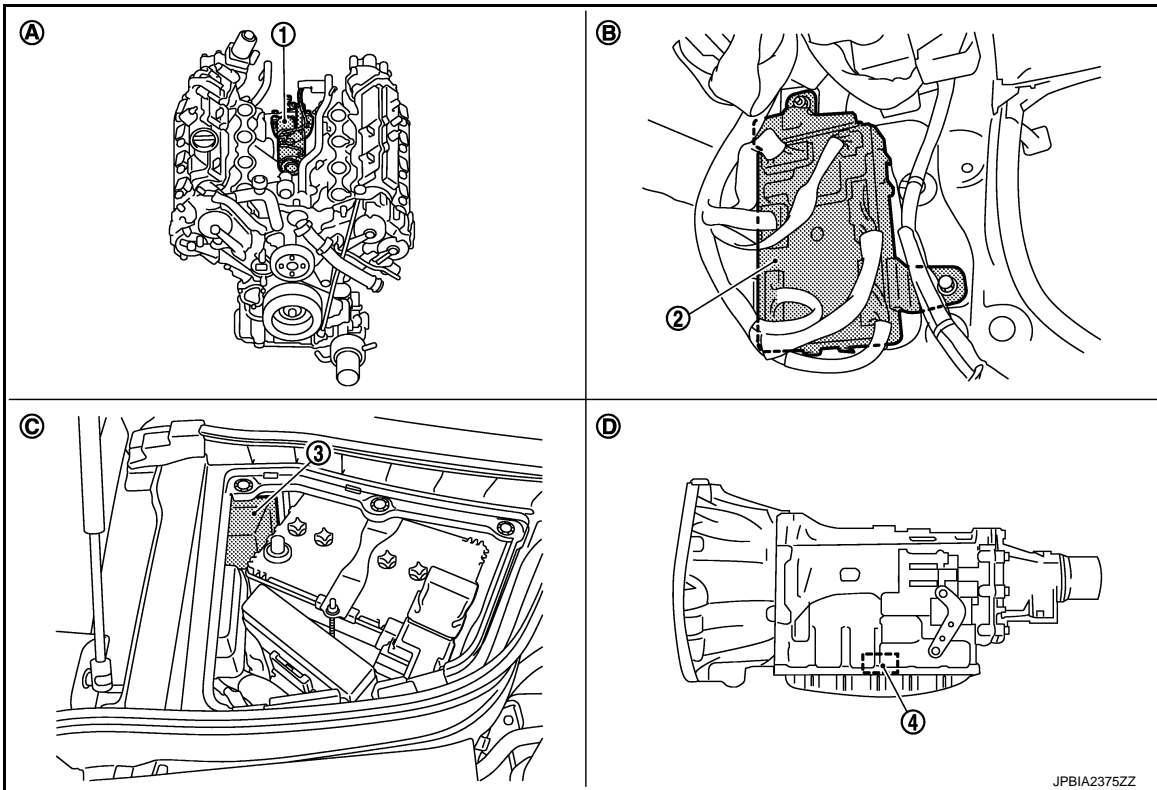

- | | | |
|-----------------------------------|-------------------------------------|--------------------------------|
| 1. Starter motor | 2. BCM | 3. IPDM E/R |
| 4. TCM | | |
| A. Engine | B. Dash side lower (Passenger side) | C. Engine room dash panel (RH) |
| D. Inside of A/T (built into A/T) | | |

Component Description

INFOID:000000007519293

Component part	Description
TCM	TCM supplies power to the starter relay and starter control relay inside IPDM E/R when the selector lever is shifted to the P or N position.
BCM	BCM controls the starter relay inside IPDM E/R.
IPDM E/R	CPU inside IPDM E/R controls the starter control relay.
Starter motor	The starter motor plunger closes and the motor is supplied with battery power, which in turn cranks the engine, when the "S" terminal is supplied with electric power.

B TERMINAL CIRCUIT

< DTC/CIRCUIT DIAGNOSIS >

DTC/CIRCUIT DIAGNOSIS

B TERMINAL CIRCUIT

Description

INFOID:000000007519294

The "B" terminal is constantly supplied with battery power.

Diagnosis Procedure

INFOID:000000007519295

CAUTION:

Perform diagnosis under the condition that engine cannot start by the following procedure.

1. Remove fuel pump fuse.
2. Crank or start the engine (where possible) until the fuel pressure is released.

1. CHECK "B" TERMINAL CIRCUIT

1. Turn ignition switch OFF.
2. Check that starter motor "B" terminal connection is clean and tight.
3. Check voltage between starter motor "B" terminal and ground.

Terminals		Voltage (Approx.)
(+)	(-)	
Starter motor "B" terminal	Terminal	Battery voltage
E204 (VQ35HR) E206 (VK50VE)	2	
	Ground	

Is the inspection result normal?

YES >> GO TO 2.

NO >> Check harness between battery and starter motor for open circuit.

2. CHECK BATTERY CABLE CONNECTION STATUS (VOLTAGE DROP TEST)

1. Shift A/T selector lever to "P" or "N" position.
2. Check voltage between battery positive terminal and starter motor "B" terminal.

Terminals		Condition	Voltage (Approx.)
(+)	(-)		
Battery positive terminal	Starter motor "B" terminal	When the ignition switch is in START position	Less than 0.5 V
	E204 (VQ35HR) E206 (VK50VE)		

Is the inspection result normal?

YES >> GO TO 3.

NO >> Check harness between the battery and the starter motor for poor continuity.

3. CHECK GROUND CIRCUIT STATUS (VOLTAGE DROP TEST)

1. Shift A/T selector lever to "P" or "N" position.
2. Check voltage between starter motor case and battery negative terminal.

Terminals		Condition	Voltage (Approx.)
(+)	(-)		
Starter motor case	Battery negative terminal	When the ignition switch is in START position	Less than 0.2 V

Is the inspection result normal?

YES >> "B" terminal circuit is OK. Further inspection is necessary. Refer to [STR-2, "Work Flow"](#).

NO >> Check the starter motor case and ground for poor continuity.

S CONNECTOR CIRCUIT

< DTC/CIRCUIT DIAGNOSIS >

S CONNECTOR CIRCUIT

Description

INFOID:000000007519296

The starter motor magnetic switch is supplied with power when the ignition switch is turned to the START position while the selector lever is in the P or N position.

A
STR

Diagnosis Procedure

INFOID:000000007519297

CAUTION:

Perform diagnosis under the condition that engine cannot start by the following procedure.

1. Remove fuel pump fuse.
2. Crank or start the engine (where possible) until the fuel pressure is released.

1. CHECK "S" CONNECTOR CIRCUIT

1. Turn ignition switch OFF.
2. Disconnect starter motor connector.
3. Shift A/T selector lever to "P" or "N" position.
4. Check voltage between starter motor harness connector and ground.

Terminals		(-)	Condition	Voltage (Approx.)
(+)	Terminal			
Starter motor harness connector	1	Ground	When the ignition switch is in START position	Battery voltage

Is the inspection result normal?

- YES >> "S" connector circuit is OK. Further inspection is necessary. Refer to [STR-2, "Work Flow"](#).
NO >> GO TO 2.

2. CHECK HARNESS CONTINUITY (OPEN CIRCUIT)

1. Disconnect IPDM E/R connector.
2. Check continuity between starter motor harness connector and IPDM E/R harness connector.

Starter motor harness connector		IPDM E/R harness connector		Continuity
Connector No.	Terminal No.	Connector No.	Terminal No.	
F52 (VQ35HR) F55 (VK50VE)	1	E7	80	Existed

Is the inspection result normal?

- YES >> Further inspection is necessary. Refer to [STR-2, "Work Flow"](#).
NO >> Repair the harness.

C
D
E
F
G
H
I
J
K
L
M
N
O
P

STARTING SYSTEM

< SYMPTOM DIAGNOSIS >

SYMPTOM DIAGNOSIS

STARTING SYSTEM

Symptom Table

INFOID:000000007519300

A

STR

Symptom	Reference
No normal cranking	Refer to STR-2, "Work Flow" .
Starter motor does not rotate	

C

D

E

F

G

H

I

J

K

L

M

N

O

P

PRECAUTIONS

< PRECAUTION >

PRECAUTION

PRECAUTIONS

Precaution for Supplemental Restraint System (SRS) "AIR BAG" and "SEAT BELT PRE-TENSIONER"

INFOID:000000007519301

The Supplemental Restraint System such as "AIR BAG" and "SEAT BELT PRE-TENSIONER", used along with a front seat belt, helps to reduce the risk or severity of injury to the driver and front passenger for certain types of collision. This system includes seat belt switch inputs and dual stage front air bag modules. The SRS system uses the seat belt switches to determine the front air bag deployment, and may only deploy one front air bag, depending on the severity of a collision and whether the front occupants are belted or unbelted. Information necessary to service the system safely is included in the "SRS AIR BAG" and "SEAT BELT" of this Service Manual.

WARNING:

Always observe the following items for preventing accidental activation.

- To avoid rendering the SRS inoperative, which could increase the risk of personal injury or death in the event of a collision that would result in air bag inflation, all maintenance must be performed by an authorized NISSAN/INFINITI dealer.
- Improper maintenance, including incorrect removal and installation of the SRS, can lead to personal injury caused by unintentional activation of the system. For removal of Spiral Cable and Air Bag Module, see "SRS AIR BAG".
- Never use electrical test equipment on any circuit related to the SRS unless instructed to in this Service Manual. SRS wiring harnesses can be identified by yellow and/or orange harnesses or harness connectors.

PRECAUTIONS WHEN USING POWER TOOLS (AIR OR ELECTRIC) AND HAMMERS

WARNING:

Always observe the following items for preventing accidental activation.

- When working near the Air Bag Diagnosis Sensor Unit or other Air Bag System sensors with the ignition ON or engine running, never use air or electric power tools or strike near the sensor(s) with a hammer. Heavy vibration could activate the sensor(s) and deploy the air bag(s), possibly causing serious injury.
- When using air or electric power tools or hammers, always switch the ignition OFF, disconnect the battery, and wait at least 3 minutes before performing any service.

Precaution for Procedure without Cowl Top Cover

INFOID:000000007795682

When performing the procedure after removing cowl top cover, cover the lower end of windshield with urethane, etc to prevent damage to windshield.

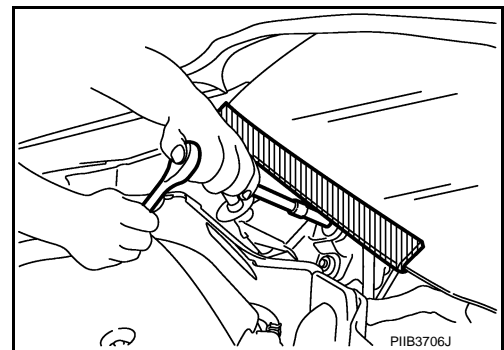

Precautions For Xenon Headlamp Service

INFOID:000000007795683

WARNING:

Comply with the following warnings to prevent any serious accident.

- Disconnect the battery cable (negative terminal) or the power supply fuse before installing, removing, or touching the xenon headlamp (bulb included). The xenon headlamp contains high-voltage generated parts.
- Never work with wet hands.
- Check the xenon headlamp ON-OFF status after assembling it to the vehicle. Never turn the xenon headlamp ON in other conditions. Connect the power supply to the vehicle-side connector.

PRECAUTIONS

< PRECAUTION >

(Turning it ON outside the lamp case may cause fire or visual impairments.)

- Never touch the bulb glass immediately after turning it OFF. It is extremely hot.

CAUTION:

Comply with the following cautions to prevent any error and malfunction.

- Install the xenon bulb securely. (Insufficient bulb socket installation may melt the bulb, the connector, the housing, etc. by high-voltage leakage or corona discharge.)
- Never perform HID circuit inspection with a tester.
- Never touch the xenon bulb glass with hands. Never put oil and grease on it.
- Dispose of the used xenon bulb after packing it in thick vinyl without breaking it.
- Never wipe out dirt and contamination with organic solvent (thinner, gasoline, etc.).

A

STR

C

D

E

F

G

H

I

J

K

L

M

N

O

P

PREPARATION

< PREPARATION >

PREPARATION

PREPARATION

Special Service Tools

INFOID:000000007519302

Tool number (Kent-Moore No.) Tool name	Description
<p>— (J-44373 Model MCR620) Starting/Charging System Tester</p>  <p>SEL403X</p>	<p>Tests starting and charging systems. For operating instructions, refer to Technical Service Bulletin.</p>

Commercial Service Tools

INFOID:000000007519303

Tool name	Description
<p>Power tool</p>  <p>PIIB1407E</p>	<p>Loosening bolts, nuts and screws</p>

STARTER MOTOR

< REMOVAL AND INSTALLATION >

REMOVAL AND INSTALLATION

STARTER MOTOR

VQ35HR

VQ35HR : Exploded View

INFOID:000000007519304

A

STR

REMOVAL

C

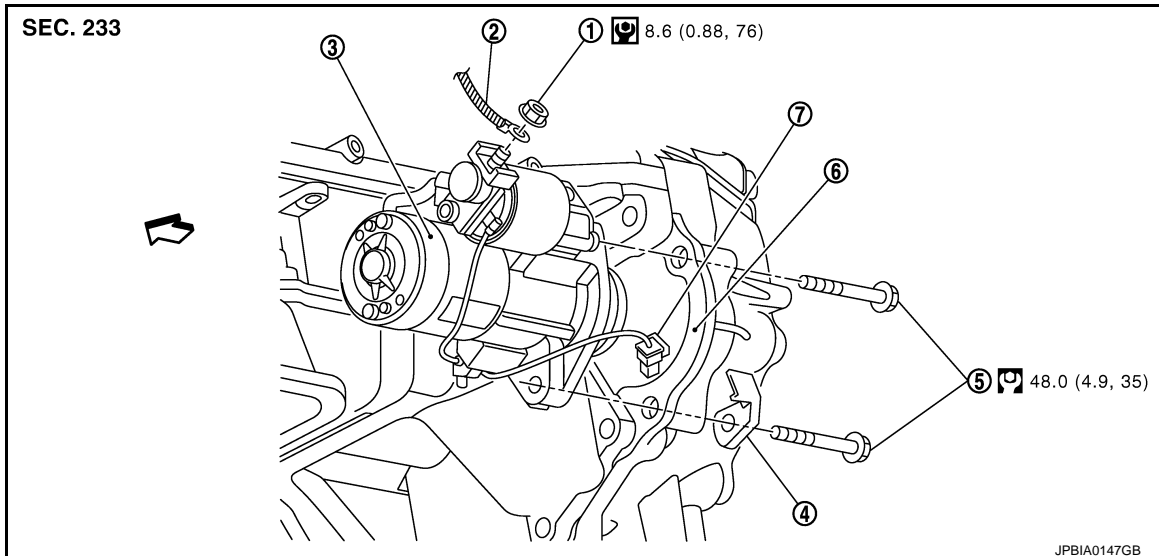

D

E

F

G

H

- | | | |
|-------------------------|--------------------------------|----------------------|
| 1. "B" terminal nut | 2. "B" terminal harness | 3. Starter motor |
| 4. Harness clip bracket | 5. Starter motor mounting bolt | 6. Converter housing |
| 7. "S" connector | | |

I

⇐: Engine front

J

Refer to [GI-4, "Components"](#) for symbols in the figure.

DISASSEMBLY

K

L

M

N

O

P

STARTER MOTOR

< REMOVAL AND INSTALLATION >

Type: S114-927

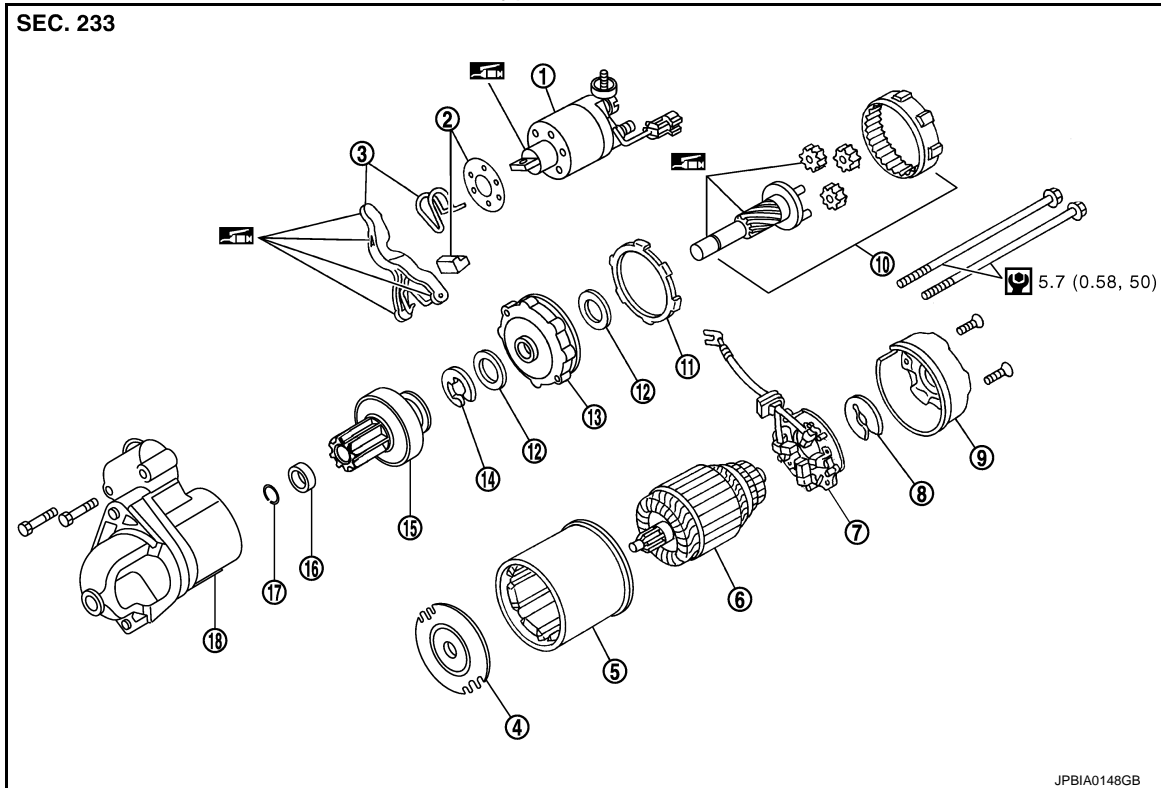

- | | | |
|-----------------------------|-------------------------|------------------------|
| 1. Magnetic switch assembly | 2. Dust cover kit | 3. Shift lever set |
| 4. Center bracket (A) | 5. Yoke assembly | 6. Armature assembly |
| 7. Brush holder assembly | 8. Thrust washer | 9. Rear cover assembly |
| 10. Shaft gear assembly | 11. Packing | 12. Thrust washer |
| 13. Center bracket (P) | 14. E-ring | 15. Pinion assembly |
| 16. Pinion stopper | 17. Pinion stopper clip | 18. Gear case assembly |

 High-temperature grease point

Refer to [GI-4, "Components"](#) for symbols not described on the above.

VQ35HR : Removal and Installation (2WD)

INFOID:000000007519305

Removal

1. Disconnect the battery cable from the negative terminal.
2. Remove engine undercover using power tools.
3. Remove "B" terminal nut (1).

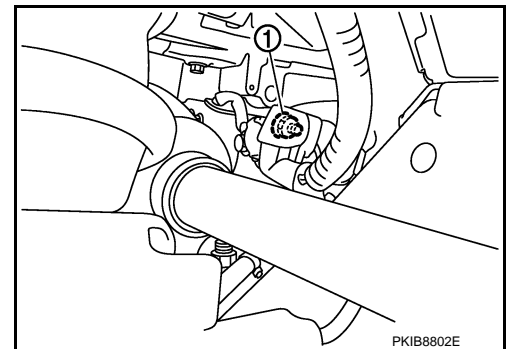

STARTER MOTOR

< REMOVAL AND INSTALLATION >

4. Disconnect "S" connector (1).
5. Remove starter motor mounting bolts (A) and harness bracket (2), using power tools.

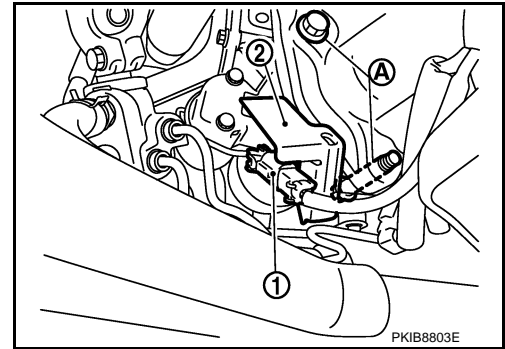

6. Remove compressor bracket bolts (A).
7. Remove compressor bracket (1).

↔ : Vehicle front

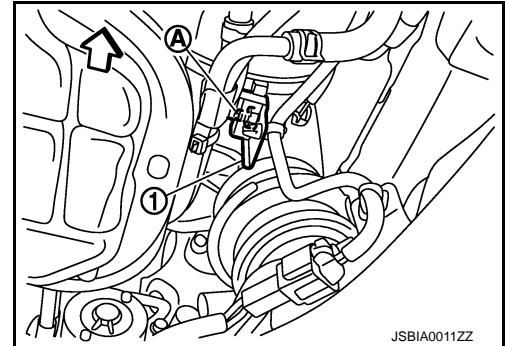

8. Remove A/T fluid cooler tube clip bolts and bracket. Refer to [TM-197, "2WD : Exploded View"](#).
9. Move A/T fluid cooler tube (1) downward.
10. Remove starter motor (2) forward from the vehicle.

↔ : Vehicle front

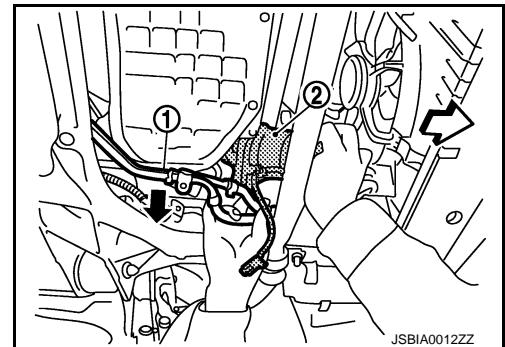

INSTALLATION

Install in the reverse order of removal.

CAUTION:

Be sure to tighten "B" terminal nut carefully.

VQ35HR : Removal and Installation (AWD)

INFOID:000000007519306

Removal

1. Disconnect the battery cable from the negative terminal.
2. Remove engine undercover, using power tools.
3. Remove "B" terminal nut (1).

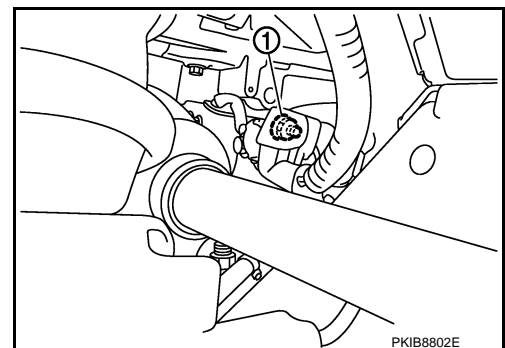

A
STR
C
D
E
F
G
H
I
J
K
L
M
N
O
P

STARTER MOTOR

< REMOVAL AND INSTALLATION >

4. Disconnect "S" connector (1).
5. Remove starter motor mounting bolts (A) and harness bracket (2), using power tools.

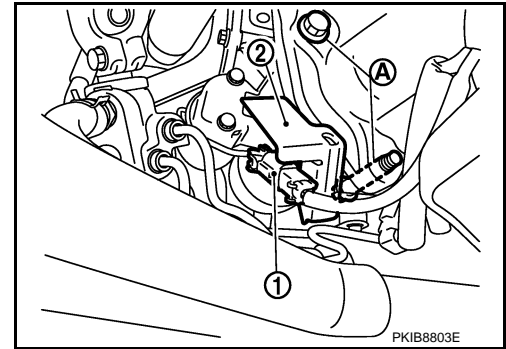

6. Remove front drive shaft left side housing bolts. Refer to [FAX-26. "Exploded View"](#).
7. Move a front drive shaft left side forward.
8. Remove stater motor (1) to left side from the vehicle.

↶ : Vehicle front

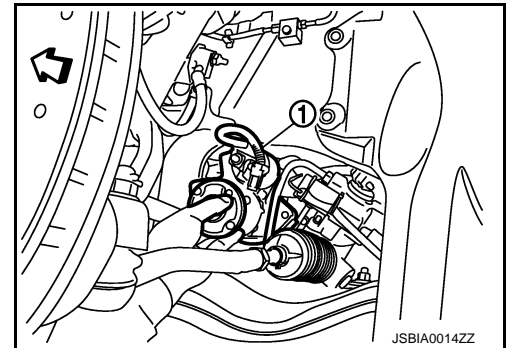

INSTALLATION

Install in the reverse order of removal.

CAUTION:

Be sure to tighten "B" terminal nut carefully.

VQ35HR : Inspection

INFOID:000000007519307

INSPECTION AFTER DISASSEMBLY

Pinion/Clutch Check

1. Inspect pinion teeth.
 - Replace pinion if teeth are worn or damaged. (Also check condition of ring gear teeth.)
2. Inspect reduction gear teeth.
 - Replace reduction gear if teeth are worn or damaged. (Also check condition of armature shaft gear teeth.)
3. Check to see if pinion locks in one direction and rotates smoothly in the opposite direction.
 - If it locks or rotates in both directions, or unusual resistance is evident, replace.

VK50VE

VK50VE : Exploded View

INFOID:000000007519308

REMOVAL

STARTER MOTOR

< REMOVAL AND INSTALLATION >

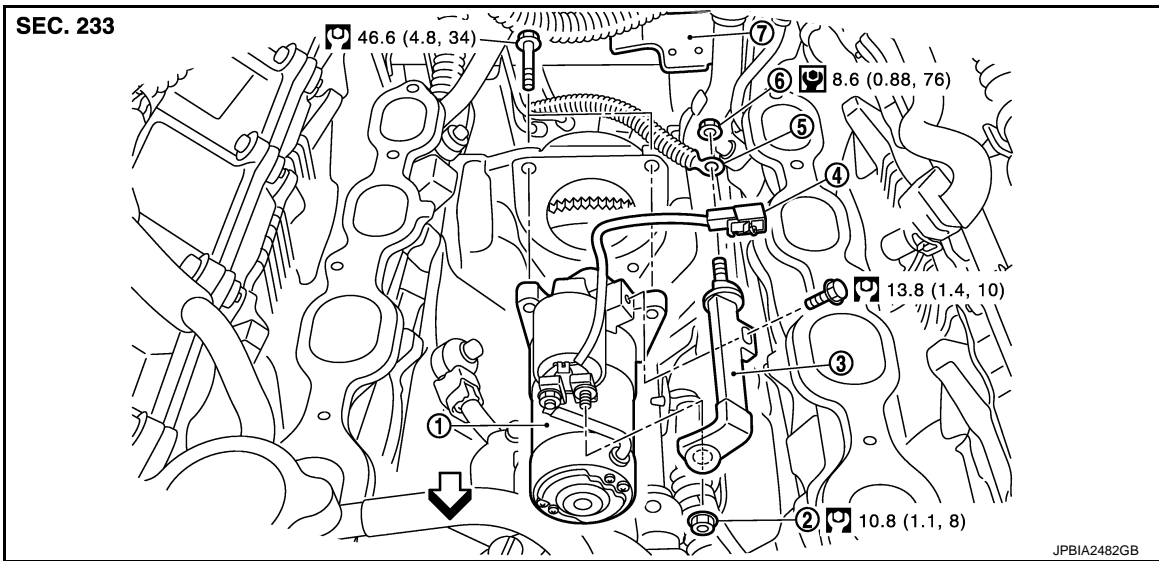

- | | | |
|--------------------------|-------------------------------|---------------------------|
| 1. Starter motor | 2. "B" terminal extension nut | 3. "B" terminal extension |
| 4. "S" connector | 5. "B" terminal harness | 6. "B" terminal nut |
| 7. "S" connector bracket | | |

⇐ Engine front

Refer to [GI-4, "Components"](#) for symbols in the figure.

DISASSEMBLY

Type: M001T30671

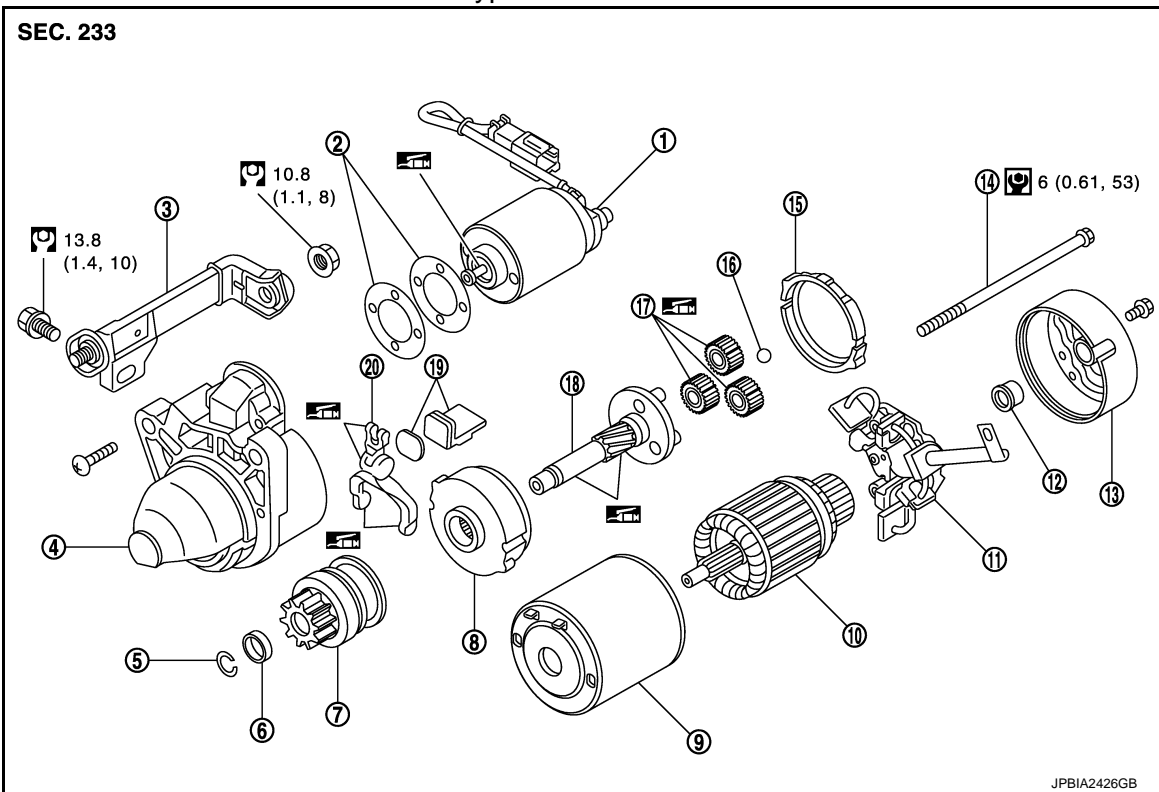

- | | | |
|-----------------------------|---------------------------|---------------------------|
| 1. Magnetic switch assembly | 2. Adjusting plate | 3. "B" terminal extension |
| 4. Gear case assembly | 5. Stopper ring | 6. Stopper |
| 7. Pinion assembly | 8. Internal gear | 9. Yoke assembly |
| 10. Armature assembly | 11. Brush holder assembly | 12. Metal RR |

STARTER MOTOR

< REMOVAL AND INSTALLATION >

- | | | |
|--------------------|--------------------|----------------|
| 13. Rear cover | 14. Through bolt | 15. Packing |
| 16. Ball | 17. Planetary gear | 18. Gear shaft |
| 19. Dust cover kit | 20. Shift lever | |

 High-temperature grease point

Refer to [GI-4. "Components"](#) for symbols not described on the above.

VK50VE : Removal and Installation

INFOID:000000007519309

REMOVAL

1. Disconnect the battery cable from the negative terminal.
2. Remove engine cover, using power tools. Refer to [EM-175. "Exploded View"](#).
3. Remove intake manifold. Refer to [EM-180. "Exploded View"](#).
4. Remove "B" terminal nut.
5. Disconnect "S" connector.
6. Remove starter motor mounting bolts using power tools.
7. Remove starter motor upward from the vehicle.

INSTALLATION

Install in the reverse order of removal.

CAUTION:

Be sure to tighten "B" terminal nut carefully.

VK50VE : Inspection

INFOID:000000007519310

INSPECTION AFTER DISASSEMBLY

Pinion/Clutch Check

1. Inspect pinion teeth.
 - Replace pinion if teeth are worn or damaged. (Also check condition of ring gear teeth.)
2. Inspect reduction gear teeth.
 - Replace reduction gear if teeth are worn or damaged. (Also check condition of armature shaft gear teeth.)
3. Check to see if pinion locks in one direction and rotates smoothly in the opposite direction.
 - If it locks or rotates in both directions, or unusual resistance is evident, replace.

SERVICE DATA AND SPECIFICATIONS (SDS)

< SERVICE DATA AND SPECIFICATIONS (SDS)

SERVICE DATA AND SPECIFICATIONS (SDS)

SERVICE DATA AND SPECIFICATIONS (SDS)

Starter Motor

INFOID:000000007519311

A

STR

Applied model		VQ35HR	VK50VE
		S114-927	M001T30671
Type		HITACHI make	mitsubishi make
		Reduction gear type	
System voltage [V]		12	
No-load	Terminal voltage [V]	11	
	Current [A]	Less than 110	Less than 120
	Revolution [rpm]	More than 2,700	More than 3,220
Minimum diameter of commutator [mm. (in)]		28.0 (1.102)	28.8 (1.134)
Minimum length of brush [mm. (in)]		10.5 (0.413)	10.0 (0.394)
Brush spring tension [N (kg, lb.)]		16.2 (1.65, 3.6)	23.4 – 31.6 (2.4, 5.3 – 3.2, 7.1)
Clearance between bearing metal and armature shaft [mm. (in)]		Less than 0.2 (0.008)	Less than 0.2 (0.008)
Clearance between pinion front edge and pinion stopper [mm. (in)]		0.3 - 2.5 (0.012 – 0.098)	0.5 – 2.0 (0.02 – 0.079)

C

D

E

F

G

H

I

J

K

L

M

N

O

P