

SECTION **DLN**
DRIVELINE

A
B
C

DLN

CONTENTS

E

TRANSFER: TX15B

BASIC INSPECTION	8	DTC Logic	26	F
DIAGNOSIS AND REPAIR WORKFLOW	8	Diagnosis Procedure	26	
Work Flow	8	P1808 VEHICLE SPEED SENSOR (ABS)	27	G
SYSTEM DESCRIPTION	10	Description	27	
4WD SYSTEM	10	DTC Logic	27	
System Diagram	10	Diagnosis Procedure	27	H
System Description	11	P1810 4 LO SWITCH	28	
Component Parts Location	13	Description	28	I
CAN Communication	14	DTC Logic	28	
Cross-Sectional View	14	Diagnosis Procedure	28	
Power Transfer	15	Component Inspection	30	J
DIAGNOSIS SYSTEM (TRANSFER CONTROL UNIT)	17	P1813 4WD SHIFT SWITCH	31	
CONSULT Function (ALL MODE AWD/4WD)	17	Description	31	K
NOISE, VIBRATION AND HARSHNESS (NVH) TROUBLESHOOTING	20	DTC Logic	31	
NVH Troubleshooting Chart	20	Diagnosis Procedure	31	
DTC/CIRCUIT DIAGNOSIS	21	Component Inspection	33	L
P1801, P1811 POWER SUPPLY CIRCUIT FOR TRANSFER CONTROL UNIT	21	P1814 WAIT DETECTION SWITCH	34	
Description	21	Description	34	M
DTC Logic	21	DTC Logic	34	
Diagnosis Procedure	21	Diagnosis Procedure	34	
Component Inspection	23	Component Inspection	36	N
P1802 – P1804, P1809 TRANSFER CONTROL UNIT	24	P1816 PNP SWITCH (A/T)	37	
Description	24	Description	37	O
DTC Logic	24	DTC Logic	37	
Diagnosis Procedure	24	Diagnosis Procedure	37	
P1807 VEHICLE SPEED SENSOR (A/T)	26	P1816 PNP SWITCH (M/T)	38	P
Description	26	Description	38	
		DTC Logic	38	
		Diagnosis Procedure	38	
		Component Inspection	39	
		P1817 ACTUATOR MOTOR	41	
		Description	41	
		DTC Logic	41	
		Diagnosis Procedure	41	
		Component Inspection	46	

P1818 ACTUATOR POSITION SWITCH	48	ATP SWITCH	83
Description	48	Description	83
DTC Logic	48	Diagnosis Procedure	83
Diagnosis Procedure	48	Component Inspection	85
P1819 TRANSFER CONTROL DEVICE	51	PRECAUTION	86
Description	51	PRECAUTIONS	86
DTC Logic	51	Precaution for Supplemental Restraint System (SRS) "AIR BAG" and "SEAT BELT PRE-TENSIONER"	86
Diagnosis Procedure	51	Precaution for Transfer Assembly and Transfer Control Unit Replacement	86
P1820 ENGINE SPEED SIGNAL	54	Precaution	88
Description	54	Service Notice	89
DTC Logic	54	PREPARATION	90
Diagnosis Procedure	54	PREPARATION	90
U1010 CONTROL UNIT (CAN)	55	Special Service Tool	90
Description	55	Commercial Service Tool	92
DTC Logic	55	PERIODIC MAINTENANCE	93
Diagnosis Procedure	55	TRANSFER FLUID	93
ECU DIAGNOSIS INFORMATION	56	Replacement	93
TRANSFER CONTROL UNIT	56	Inspection	93
Reference Value	56	REMOVAL AND INSTALLATION	95
DTC Index	60	TRANSFER CONTROL UNIT	95
WIRING DIAGRAM	63	Removal and Installation	95
PART TIME 4WD SYSTEM	63	FRONT OIL SEAL	96
Wiring Diagram	63	Removal and Installation	96
SYMPTOM DIAGNOSIS	72	REAR OIL SEAL	98
4WD SYSTEM SYMPTOMS	72	Removal and Installation	98
Symptom Table	72	TRANSFER CONTROL DEVICE	100
4WD WARNING LAMP DOES NOT TURN ON ..	73	Removal and Installation	100
Description	73	AIR BREATHER HOSE	102
Diagnosis Procedure	73	Removal and Installation	102
4WD SHIFT INDICATOR LAMP AND 4LO INDICATOR LAMP DO NOT TURN ON	75	UNIT REMOVAL AND INSTALLATION ...	104
Description	75	TRANSFER ASSEMBLY	104
Diagnosis Procedure	75	Removal and Installation	104
4WD SHIFT INDICATOR LAMP OR 4LO INDICATOR LAMP DO NOT CHANGE	77	UNIT DISASSEMBLY AND ASSEMBLY ..	106
Description	77	TRANSFER ASSEMBLY	106
Diagnosis Procedure	77	Exploded View	106
ATP WARNING LAMP DOES NOT TURN ON ..	79	Disassembly and Assembly	107
Description	79	PLANETARY CARRIER	123
Diagnosis Procedure	79	Disassembly and Assembly	123
4WD SHIFT INDICATOR LAMP KEEPS FLASHING	81	FRONT DRIVE SHAFT	127
Description	81	Disassembly and Assembly	127
Diagnosis Procedure	81	SHIFT CONTROL	129
4WD WARNING LAMP FLASHES SLOWLY ...	82		
Description	82		
Diagnosis Procedure	82		

Disassembly and Assembly	129	PREPARATION	143	
SERVICE DATA AND SPECIFICATIONS (SDS)	132	Commercial Service Tool	143	A
SERVICE DATA AND SPECIFICATIONS (SDS)	132	SYSTEM DESCRIPTION	144	
General Specification	132	NOISE, VIBRATION, AND HARSHNESS (NVH) TROUBLESHOOTING	144	B
Inspection and Adjustment	132	NVH Troubleshooting Chart	144	C
PROPELLER SHAFT: 2F1310		BASIC INSPECTION	145	
PRECAUTION	133	PROPELLER SHAFT ASSEMBLY	145	DLN
PRECAUTIONS	133	Inspection	145	
Precaution for Supplemental Restraint System (SRS) "AIR BAG" and "SEAT BELT PRE-TENSIONER"	133	UNIT REMOVAL AND INSTALLATION ...	146	E
PREPARATION	134	PROPELLER SHAFT	146	
PREPARATION	134	Removal and Installation	146	F
Commercial Service Tool	134	UNIT DISASSEMBLY AND ASSEMBLY .	148	
SYSTEM DESCRIPTION	135	PROPELLER SHAFT	148	G
NOISE, VIBRATION, AND HARSHNESS (NVH) TROUBLESHOOTING	135	Disassembly and Assembly	148	
NVH Troubleshooting Chart	135	SERVICE DATA AND SPECIFICATIONS (SDS)	150	H
BASIC INSPECTION	136	SERVICE DATA AND SPECIFICATIONS (SDS)	150	I
PROPELLER SHAFT ASSEMBLY	136	General Specification	150	
Inspection	136	Snap Ring	150	J
UNIT REMOVAL AND INSTALLATION ...	137	PROPELLER SHAFT: 3S1310		
PROPELLER SHAFT	137	PRECAUTION	151	K
Removal and Installation	137	PRECAUTIONS	151	
UNIT DISASSEMBLY AND ASSEMBLY .	139	Precaution for Supplemental Restraint System (SRS) "AIR BAG" and "SEAT BELT PRE-TENSIONER"	151	L
PROPELLER SHAFT	139	PREPARATION	152	
Disassembly and Assembly	139	PREPARATION	152	M
SERVICE DATA AND SPECIFICATIONS (SDS)	141	Special Service Tools	152	
SERVICE DATA AND SPECIFICATIONS (SDS)	141	Commercial Service Tool	152	N
General Specification	141	SYSTEM DESCRIPTION	153	
Snap Ring	141	NOISE, VIBRATION AND HARSHNESS (NVH) TROUBLESHOOTING	153	O
PROPELLER SHAFT: 2S1330		NVH Troubleshooting Chart	153	
PRECAUTION	142	BASIC INSPECTION	154	P
PRECAUTIONS	142	PROPELLER SHAFT ASSEMBLY	154	
Precaution for Supplemental Restraint System (SRS) "AIR BAG" and "SEAT BELT PRE-TENSIONER"	142	Inspection	154	
PREPARATION	143	UNIT REMOVAL AND INSTALLATION ...	155	
		REAR PROPELLER SHAFT	155	
		Removal and Installation	155	

PERIODIC MAINTENANCE	189	Changing Differential Gear Oil	223	
		Checking Differential Gear Oil	223	A
DIFFERENTIAL GEAR OIL	189	REMOVAL AND INSTALLATION	224	
Changing Differential Gear Oil	189	FRONT OIL SEAL	224	B
Checking Differential Gear Oil	189	Removal and Installation	224	
REMOVAL AND INSTALLATION	190	CARRIER COVER	226	C
FRONT OIL SEAL	190	Removal and Installation	226	
Removal and Installation	190	UNIT REMOVAL AND INSTALLATION ...	227	DLN
SIDE OIL SEAL	192	REAR FINAL DRIVE	227	
Removal and Installation	192	Removal and Installation	227	
CARRIER COVER	193	UNIT DISASSEMBLY AND ASSEMBLY .	228	E
Removal and Installation	193	REAR FINAL DRIVE	228	
UNIT REMOVAL AND INSTALLATION ...	194	Disassembly and Assembly	228	F
FRONT FINAL DRIVE ASSEMBLY	194	SERVICE DATA AND SPECIFICATIONS		
Removal and Installation	194	(SDS)	247	G
UNIT DISASSEMBLY AND ASSEMBLY .	196	SERVICE DATA AND SPECIFICATIONS		
FRONT FINAL DRIVE	196	(SDS)	247	H
Disassembly and Assembly	196	General Specification	247	
SERVICE DATA AND SPECIFICATIONS		Inspection and Adjustment	247	
(SDS)	215	REAR FINAL DRIVE: M226		
SERVICE DATA AND SPECIFICATIONS		PRECAUTION	249	I
(SDS)	215	PRECAUTIONS	249	J
General Specification	215	Precaution for Supplemental Restraint System		
Inspection and Adjustment	215	(SRS) "AIR BAG" and "SEAT BELT PRE-TEN-		
C200		SIONER"	249	
PRECAUTION	217	Precaution for Servicing Rear Final Drive	249	K
PRECAUTIONS	217	PREPARATION	250	
Precaution for Supplemental Restraint System		PREPARATION	250	L
(SRS) "AIR BAG" and "SEAT BELT PRE-TEN-		Special Service Tool	250	
SIONER"	217	Commercial Service Tool	251	
Precaution for Servicing Rear Final Drive	217	SYSTEM DESCRIPTION	252	M
PREPARATION	218	DESCRIPTION	252	
PREPARATION	218	Cross-Sectional View	252	N
Special Service Tool	218	SYMPTOM DIAGNOSIS	253	
Commercial Service Tool	220	NOISE, VIBRATION AND HARSHNESS		
SYSTEM DESCRIPTION	221	(NVH) TROUBLESHOOTING	253	O
NOISE, VIBRATION AND HARSHNESS		NVH Troubleshooting Chart	253	
(NVH) TROUBLESHOOTING	221	PERIODIC MAINTENANCE	254	P
NVH Troubleshooting Chart	221	DIFFERENTIAL GEAR OIL	254	
DESCRIPTION	222	Changing Differential Gear Oil	254	
Cross-Sectional View	222	Checking Differential Gear Oil	254	
PERIODIC MAINTENANCE	223	REMOVAL AND INSTALLATION	255	
DIFFERENTIAL GEAR OIL	223			

FRONT OIL SEAL	255	P1834 CONTROL UNIT 1	280
Removal and Installation	255	Description	280
CARRIER COVER	257	DTC Logic	280
Removal and Installation	257	P1835 CONTROL UNIT 2	281
UNIT REMOVAL AND INSTALLATION ...	258	Description	281
REAR FINAL DRIVE ASSEMBLY	258	DTC Logic	281
Removal and Installation	258	P1836 CONTROL UNIT 3	282
UNIT DISASSEMBLY AND ASSEMBLY ..	259	Description	282
REAR FINAL DRIVE ASSEMBLY	259	DTC Logic	282
Disassembly and Assembly	259	P1837 CONTROL UNIT 4	283
SERVICE DATA AND SPECIFICATIONS		Description	283
(SDS)	268	DTC Logic	283
SERVICE DATA AND SPECIFICATIONS		Diagnosis Procedure	284
(SDS)	268	P1838 ON SWITCH	284
General Specification	268	Description	284
Inspection and Adjustment	268	DTC Logic	284
REAR FINAL DRIVE: M226 (ELD)		Diagnosis Procedure	284
BASIC INSPECTION	270	P1839 POSITION SWITCH ON	286
DIAGNOSIS AND REPAIR WORKFLOW	270	Description	286
Work Flow	270	DTC Logic	286
SYSTEM DESCRIPTION	272	Diagnosis Procedure	286
DIFFERENTIAL LOCK SYSTEM	272	P1844 RELAY	288
Cross-Sectional View	272	Description	288
System Diagram	273	DTC Logic	288
System Description	273	Diagnosis Procedure	288
Component Parts Location	274	P1847 SOLENOID CIRCUIT	289
Component Description	275	Description	289
DIAGNOSIS SYSTEM (DIFFERENTIAL		DTC Logic	289
LOCK CONTROL UNIT)	276	P1848 SOLENOID DISCONNECT	290
DIFFERENTIAL LOCK CONTROL UNIT	276	Description	290
DIFFERENTIAL LOCK CONTROL UNIT : CON-		DTC Logic	290
SULT Function (DIFF LOCK)	276	Diagnosis Procedure	290
NOISE, VIBRATION AND HARSHNESS		P1849 SOLENOID SHORT	292
(NVH) TROUBLESHOOTING	277	Description	292
NVH Troubleshooting Chart	277	DTC Logic	292
DTC/CIRCUIT DIAGNOSIS	278	Diagnosis Procedure	292
U1000 CAN COMM CIRCUIT	278	P1850 SOLENOID CURRENT	294
Description	278	Description	294
DTC Logic	278	DTC Logic	294
Diagnosis Procedure	278	Diagnosis Procedure	294
P1833 INITIAL START	279	C1203 ABS SYSTEM	296
Description	279	Description	296
DTC Logic	279	DTC Logic	296
Diagnosis Procedure	279	LOCK INDICATOR LAMP	297
		Description	297
		Component Function Check	297
		Diagnosis Procedure	297
		ECU DIAGNOSIS INFORMATION	299
		DIFFERENTIAL LOCK CONTROL UNIT	299

Reference Value	299	PERIODIC MAINTENANCE	313	
DTC Index	300	DIFFERENTIAL GEAR OIL	313	A
WIRING DIAGRAM	301	Changing Differential Gear Oil	313	
REAR FINAL DRIVE	301	Checking Differential Gear Oil	313	B
Wiring Diagram	301	REMOVAL AND INSTALLATION	314	
SYMPTOM DIAGNOSIS	306	DIFFERENTIAL LOCK CONTROL UNIT	314	C
DIFF LOCK INDICATOR LAMP INOPERA-		Removal and Installation	314	
TIVE	306	DIFFERENTIAL LOCK POSITION SWITCH ..	315	
Inspection Procedure	306	Removal and Installation	315	DLN
DIFF LOCK INDICATOR LAMP DOES NOT		FRONT OIL SEAL	319	
TURN ON WITH DIFFERENTIAL LOCK		Removal and Installation	319	E
SWITCHED ON	307	CARRIER COVER	321	
Inspection Procedure	307	Removal and Installation	321	F
DIFF LOCK INDICATOR LAMP FLASHES		UNIT REMOVAL AND INSTALLATION ...	322	
WHILE DRIVING	308	REAR FINAL DRIVE ASSEMBLY	322	G
Description	308	Removal and Installation	322	
Inspection Procedure	308	UNIT DISASSEMBLY AND ASSEMBLY .	324	H
PRECAUTION	309	REAR FINAL DRIVE	324	
PRECAUTIONS	309	Disassembly and Assembly	324	I
Precaution for Supplemental Restraint System		SERVICE DATA AND SPECIFICATIONS		
(SRS) "AIR BAG" and "SEAT BELT PRE-TEN-		(SDS)	334	J
SIONER"	309	SERVICE DATA AND SPECIFICATIONS		
Precaution	309	(SDS)	334	K
Precaution for Servicing Rear Final Drive	310	General Specification	334	
PREPARATION	311	Inspection and Adjustment	334	L
PREPARATION	311			M
Special Service Tool	311			N
Commercial Service Tool	312			O
				P

BASIC INSPECTION

DIAGNOSIS AND REPAIR WORKFLOW

Work Flow

INFOID:000000007323848

WORK FLOW

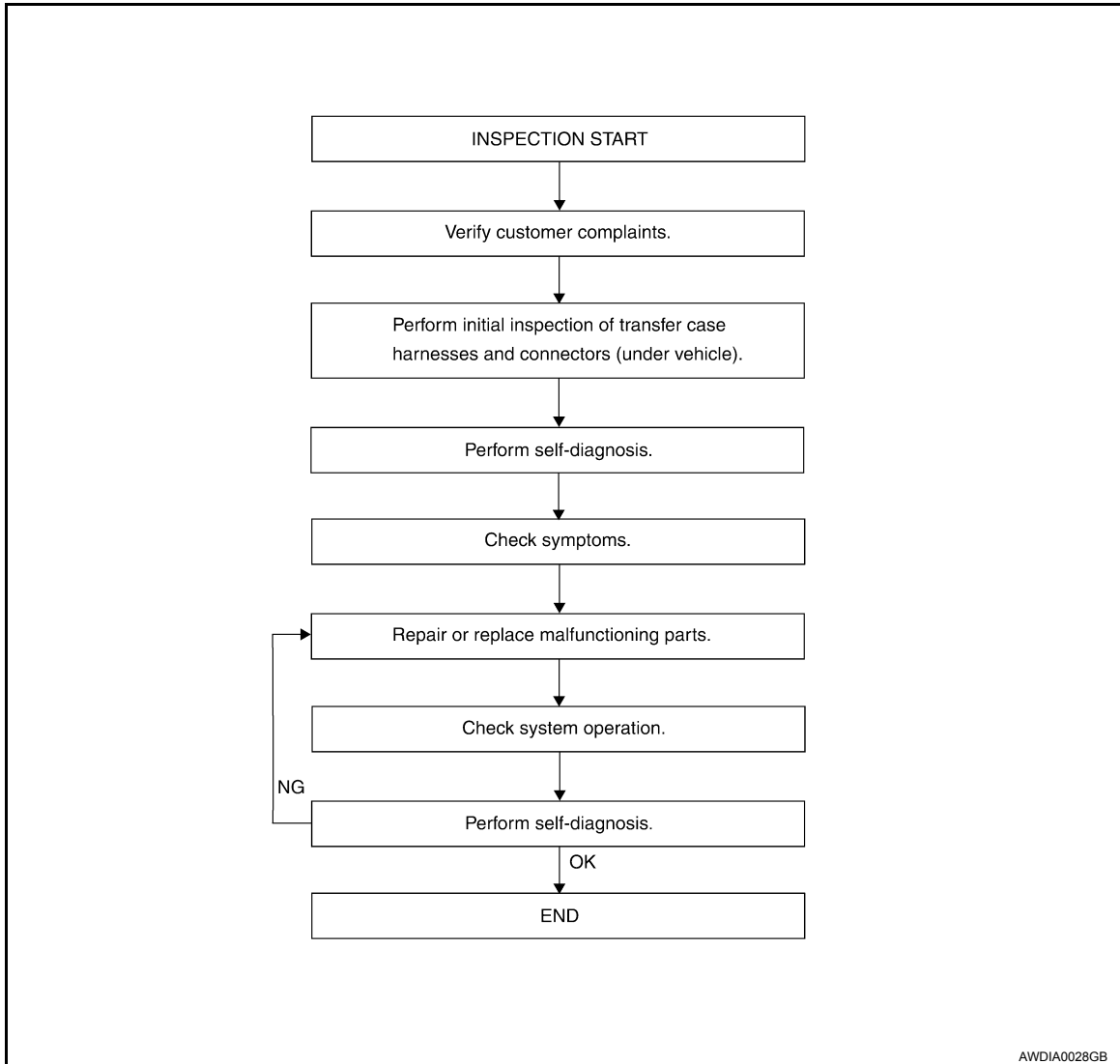

DETAILED FLOW

1. CUSTOMER INFORMATION

Interview the customer to obtain detailed information about the symptom.

>> GO TO 2

2. INITIAL INSPECTION

Perform an initial inspection of all accessible transfer case harnesses and connectors under the vehicle.

>> GO TO 3

3. SELF-DIAGNOSIS

Perform self-diagnosis. Refer to [DLN-17, "CONSULT Function \(ALL MODE AWD/4WD\)"](#).

DIAGNOSIS AND REPAIR WORKFLOW

< BASIC INSPECTION >

[TRANSFER: TX15B]

>> GO TO 4

4.SYMPTOM

Check for symptoms. Refer to [DLN-72. "Symptom Table"](#).

>> GO TO 5

5.MALFUNCTIONING PARTS

Repair or replace the applicable parts.

>> GO TO 6

6.SYSTEM OPERATION

Check system operation.

>> GO TO 7

7.SELF-DIAGNOSIS

Perform self-diagnosis.

Are any DTCs displayed?

YES >> GO TO 5

NO >> Inspection End

A

B

C

DLN

E

F

G

H

I

J

K

L

M

N

O

P

4WD SYSTEM

< SYSTEM DESCRIPTION >

[TRANSFER: TX15B]

SYSTEM DESCRIPTION

4WD SYSTEM

System Diagram

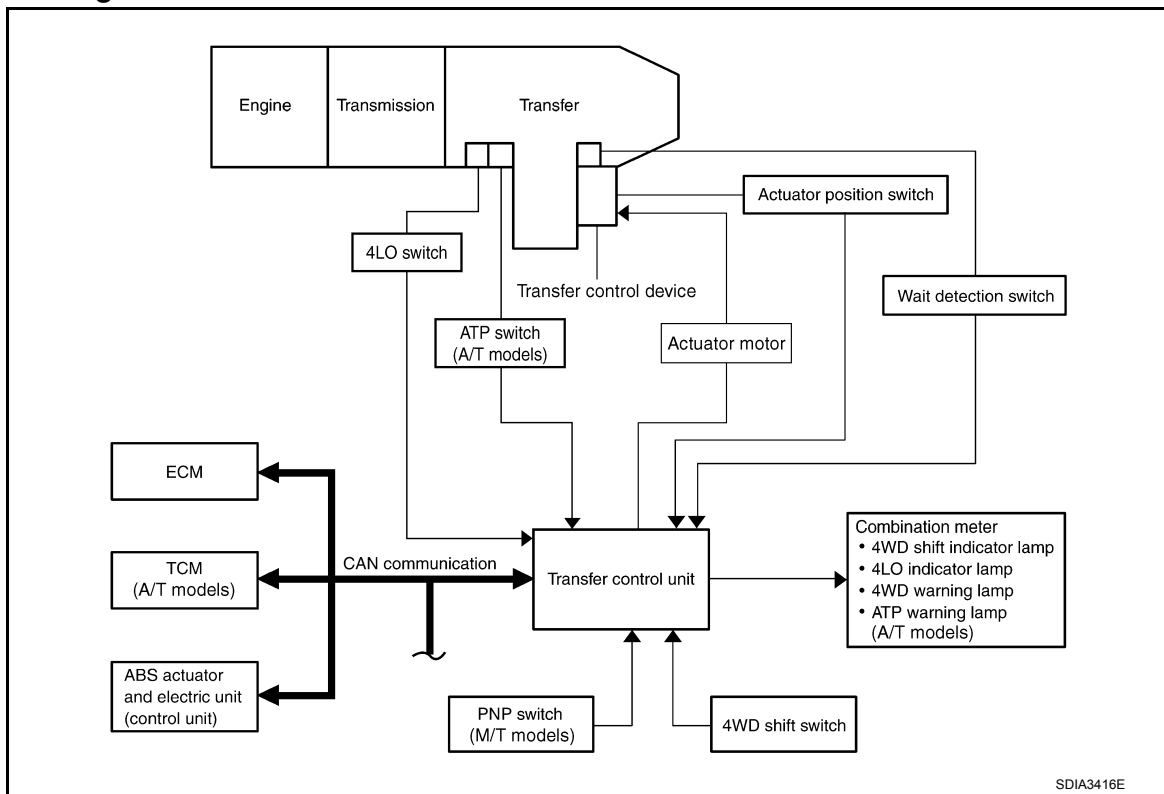

COMPONENT DESCRIPTION

Components	Function
Transfer control unit	Controls transfer control device and controls shifts between 2WD/4WD and 4H/4LO.
Transfer control device	Integrates actuator motor and actuator position switch.
Actuator motor	Moves shift rods when signalled by transfer control unit.
Actuator position switch	Detects actuator motor position.
Wait detection switch	Detects if transfer case is in 4WD.
4LO switch	Detects if transfer case is in 4LO.
ATP switch (A/T models)	Detects if transfer case is in neutral.
4WD shift switch	Allows driver to select from 2WD/4WD and 4H/4LO.
4WD warning lamp	<ul style="list-style-type: none"> • Illuminates if malfunction is detected in 4WD system. • Flashes (1 flash / 2 seconds) if rotation difference of front wheels and rear wheels is large.
ATP warning lamp (A/T models)	Indicates that A/T parking mechanism does not operate when A/T selector lever is in "P" position because transfer case is in neutral.
4WD shift indicator lamp	Displays driving range selected by 4WD shift switch.
4LO indicator lamp	Displays 4LO range.
PNP switch (M/T models)	Detects if manual transmission is under neutral condition.
ABS actuator and electric unit (control unit)	Transmits the following signals via CAN communication to transfer control unit. <ul style="list-style-type: none"> • Vehicle speed signal • Stop lamp switch signal (brake signal)

4WD SYSTEM

< SYSTEM DESCRIPTION >

[TRANSFER: TX15B]

Components	Function
TCM (A/T models)	Transmits the following signal via CAN communication to transfer control unit. <ul style="list-style-type: none">• Output shaft revolution signal• A/T position indicator signal (transmission range switch signal)
ECM	Transmits engine speed signal via CAN communication to transfer control unit.

System Description

INFOID:000000007323850

TRANSFER CONTROL DEVICE

Integrates actuator motor and actuator position switch.

Actuator Motor

Moves shift rods when signalled by transfer control unit.

Actuator Position Switch

Detects actuator motor position and then sends signal to transfer control unit.

WAIT DETECTION SWITCH

Detects if transfer case is in 4WD by the 2-4 shift fork position.

NOTE:

If 4WD shift switch is switched to 4H or 4LO and the transfer case is not in 4WD completely, the wait detection system will operate.

4LO SWITCH

4LO switch detects if the transfer case is in 4LO by the position of the L-H shift fork.

ATP SWITCH (A/T MODELS)

ATP switch detects if transfer case is in neutral by the position of the L-H shift fork.

NOTE:

Transfer case may be in neutral when shifting between 4H-4LO.

PNP SWITCH (M/T models)

PNP switch detects if manual transmission is under neutral condition.

TRANSFER CONTROL UNIT

- Transfer control unit controls transfer control device and it directs shifts from 4H-4LO and 2WD-4WD.
- Self-diagnosis can be done.

TRANSFER SHIFT HIGH AND LOW RELAYS

Transfer shift high and low relays apply power supply to transfer control device (actuator motor).

TRANSFER SHUT OFF RELAYS

Transfer shut off relays 1 and 2 apply power supply to transfer control unit.

4WD SHIFT SWITCH AND INDICATOR LAMP

A

B

C

DLN

E

F

G

H

I

J

K

L

M

N





O

P

4WD SYSTEM

< SYSTEM DESCRIPTION >

[TRANSFER: TX15B]

4WD shift switch	Indicator lamp		Operation of 4WD shift switch	Use condition
	4WD shift	4LO		
2WD		OFF	2WD⇔4H switching can be done while driving. The indicator lamp will change when the driving mode is changed. Gear shift in between 2WD⇔4H position must be performed at speeds below 100 km/h (60 MPH).	For driving on dry, paved roads.
4H				For driving on rough, sandy or snow-covered roads.
4LO		Flashing	For M/T models, to shift between 4H⇔4LO, stop the vehicle and shift the transmission shift lever to the Neutral position with the clutch pedal depressed. For A/T models, to shift between 4H⇔4LO, stop the vehicle and shift the transmission selector to the "N" position with the brake pedal depressed. Depressed and turn the 4WD shift switch. The 4WD shift switch will not shift to the desired mode if the transmission is not in "N" or the vehicle is moving. You must wait for the 4LO indicator lamp to stop flashing and remain lit or turned off before shifting your transmission into gear or releasing the clutch pedal.	The 4LO indicator lamp flashes when shifting between 4LO⇔4H.
		ON	For use when maximum power and traction is required at low speeds (for example on steep grades or rocky, sandy, muddy roads.).	

SDIA3290E

4WD Shift Switch

4WD shift switch is able to select from 2WD, 4H or 4LO.

4WD Shift Indicator Lamp

- Displays driving conditions selected by the 4WD shift switch while engine is running. When the 4WD warning lamp is turned on, all 4WD shift indicator lamps will turn off.
- Turns ON when ignition switch is turned ON, for purpose of lamp check. Turns OFF approximately for 1 second after the engine starts if system is normal.

4LO Indicator Lamp

- Displays 4LO while engine is running. 4LO indicator lamp flashes if transfer gear does not shift completely into 4H⇔4LO. In this condition, the transfer case may be in neutral and the A/T parking mechanism may not operate.
- Turns ON when ignition switch is turned ON, for purpose of lamp check. Turns OFF approximately for 1 second after the engine starts if system is normal.

4WD WARNING LAMP

Turns on or flashes when there is a malfunction in 4WD system.

Also turns on when ignition switch is turned ON, for purpose of lamp check. Turns OFF approximately for 1 second after the engine starts if system is normal.

4WD Warning Lamp Indication

Condition	4WD warning lamp
System normal	OFF
Lamp check	Turns ON when ignition switch is turned ON. Turns OFF after engine start.
4WD system malfunction	ON
During self-diagnosis	Flashes malfunction mode.
Large difference in diameter of front/rear tires	Flashes slow (1 flash / 2 seconds) (Continues to flash until the ignition switch is turned OFF)

ATP WARNING LAMP (A/T MODELS)

4WD SYSTEM

< SYSTEM DESCRIPTION >

[TRANSFER: TX15B]

When the A/T selector lever is in "P" position, the vehicle may move if the transfer case is in neutral. ATP warning lamp is turned on to indicate this condition to the driver.

Component Parts Location

INFOID:000000007323851

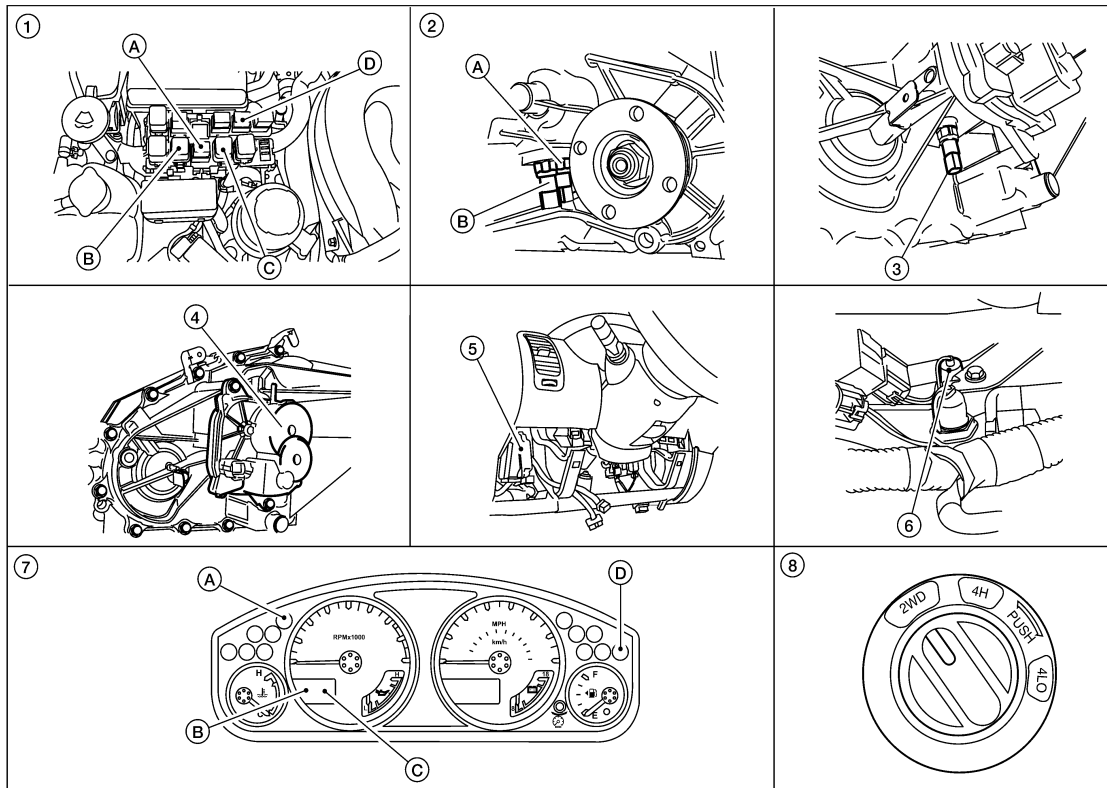
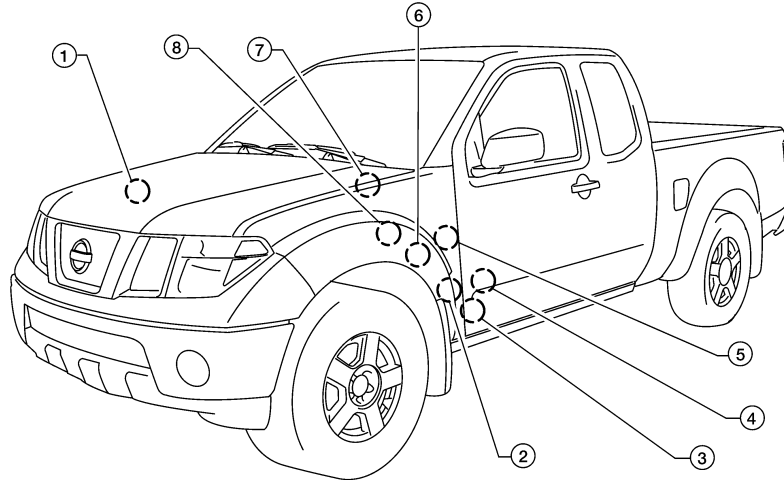

WDIA0345E

- | | | |
|---|---|-------------------------------------|
| <p>1. Fuse and relay box
 A: Transfer shut off relay 1 E156
 B: Transfer shift high relay E46
 C: Transfer shift low relay E47
 D: Transfer shut off relay 2 E157</p> | <p>2. A: ATP switch F55 (A/T models)
 B: 4 LO switch F60
 (View with front propeller shaft re-
 moved.)</p> | <p>3. Wait detection switch F59</p> |
|---|---|-------------------------------------|

A
B
C
DLN
E
F
G
H
I
J
K
L
M
N
O
P

4WD SYSTEM

< SYSTEM DESCRIPTION >

[TRANSFER: TX15B]

- | | | |
|---|---|---|
| 4. Transfer control device F58 | 5. Transfer control unit M152, M153
(View with lower instrument panel LH removed.) | 6. Park/neutral position switch F66
(M/T models) |
| 7. Combination meter M24
A: 4WD warning lamp
B: 4LO indicator lamp
C: 4WD shift indicator lamp
D: ATP warning lamp (A/T models) | 8. 4WD shift switch M141 | |

CAN Communication

INFOID:000000007323852

Refer to [LAN-4, "System Description"](#).

Cross-Sectional View

INFOID:000000007323853

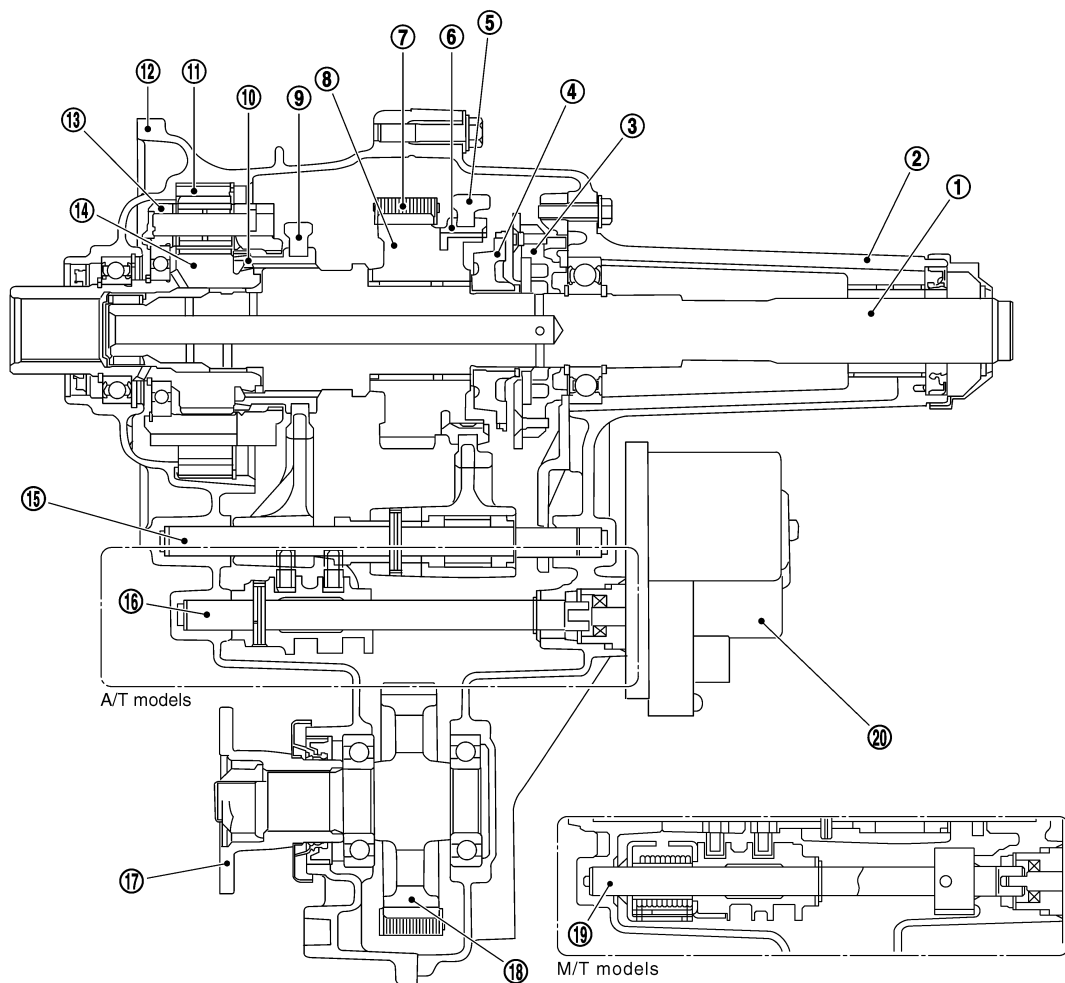

SDIA3418E

- | | | |
|--------------------------------|-----------------------------|-----------------------|
| 1. Mainshaft | 2. Rear case | 3. Oil pump assembly |
| 4. Clutch gear | 5. 2-4 shift fork | 6. 2-4 sleeve |
| 7. Drive chain | 8. Sprocket | 9. L-H shift fork |
| 10. L-H sleeve | 11. Internal gear | 12. Front case |
| 13. Planetary carrier assembly | 14. Sun gear assembly | 15. L-H shift rod |
| 16. Control shift rod A/T | 17. Companion flange | 18. Front drive shaft |
| 19. Control shift rod M/T | 20. Transfer control device | |

4WD SYSTEM

< SYSTEM DESCRIPTION >

[TRANSFER: TX15B]

INFOID:000000007323854

Power Transfer

POWER TRANSFER DIAGRAM

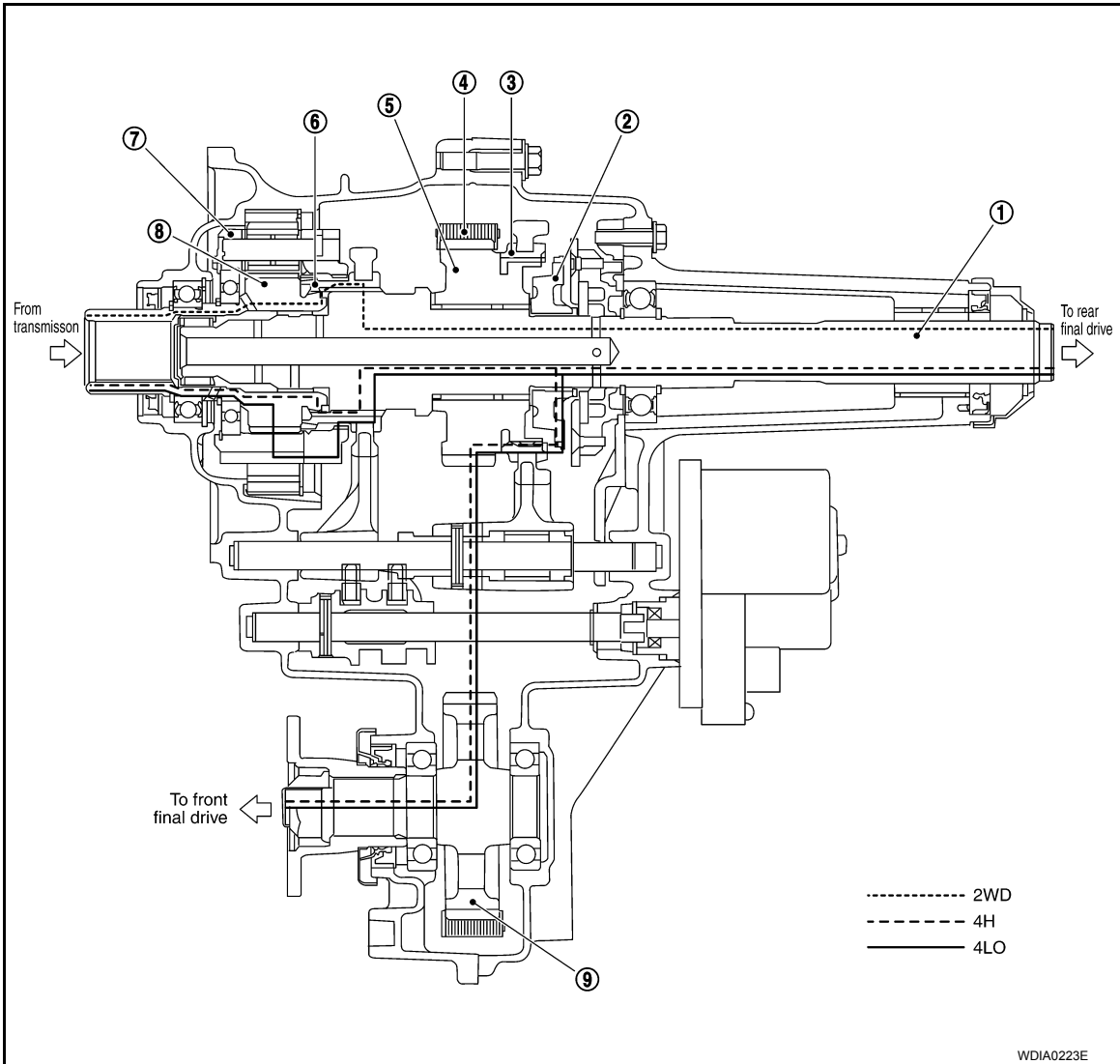

- | | | |
|-------------------------------|----------------------|----------------------|
| 1. Mainshaft | 2. Clutch gear | 3. 2-4 sleeve |
| 4. Drive chain | 5. Sprocket | 6. L-H sleeve |
| 7. Planetary carrier assembly | 8. Sun gear assembly | 9. Front drive shaft |

POWER TRANSFER FLOW

A
B
C
DLN
E
F
G
H
I
J
K
L
M
N
O
P

4WD SYSTEM

< SYSTEM DESCRIPTION >

[TRANSFER: TX15B]

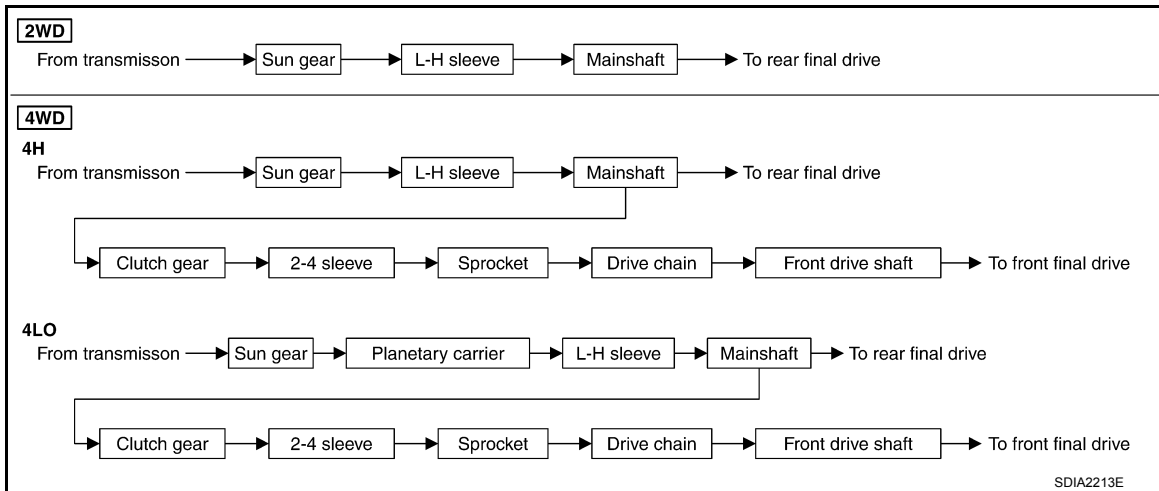

DIAGNOSIS SYSTEM (TRANSFER CONTROL UNIT)

< SYSTEM DESCRIPTION >

[TRANSFER: TX15B]

DIAGNOSIS SYSTEM (TRANSFER CONTROL UNIT)

CONSULT Function (ALL MODE AWD/4WD)

INFOID:000000007323855

FUNCTION

CONSULT can display each diagnostic item using the following direct diagnostic modes.

Direct Diagnostic Mode	Description
Self Diagnostic Result	The transfer control unit self diagnostic results are displayed.
Data Monitor	The transfer control unit input/output data is displayed in real time.
CAN Diag Support Monitor	The result of transmit/receive diagnosis of CAN communication is displayed.

SELF DIAGNOSTIC RESULT

Operation Procedure

1. Connect "CONSULT".
2. With engine at idle, touch "SELF-DIAG RESULTS".
Display shows malfunction experienced since the last erasing operation.

NOTE:

The details for "TIME" are as follows:

- "0": Error currently detected with transfer control unit.
- Except for "0": Error detected in the past and memorized with transfer control unit.
Detects frequency of driving after DTC occurs (frequency of turning ignition switch "ON/OFF").

How to Erase Self-diagnostic Results

1. Perform applicable inspection of malfunctioning item and then repair or replace.
2. Start engine and select "SELF-DIAG RESULTS" mode for "ALL MODE AWD/4WD" with CONSULT.
3. Touch "ERASE" on CONSULT screen to erase DTC memory.

CAUTION:

If memory cannot be erased, perform applicable diagnosis.

⊗ SELF-DIAGNOSTIC PROCEDURE (WITHOUT CONSULT)

Description

If the engine starts when there is something wrong with the 4WD system, the 4WD warning lamp turns ON or flickers in the combination meter. When the system functions properly, the warning lamp turns ON when the ignition switch is turned to "ON", and it turns OFF after engine starts. To locate the cause of a problem, start the self-diagnosis function. The 4WD warning lamp in the combination meter will indicate the problem area by flickering according to the self-diagnostic results. Refer to [DLN-60, "DTC Index"](#).

Diagnostic Procedure (A/T models)

1. Warm up engine.
2. Turn ignition switch "ON" and "OFF" at least twice, and then turn ignition switch "OFF".
3. Move A/T selector lever to "P" position.
4. Turn 4WD shift switch to "2WD" position.
5. Turn ignition switch "ON". (Do not start engine.)
6. 4WD warning lamp should turn ON.
If 4WD warning lamp does not turn ON, refer to [DLN-73, "Diagnosis Procedure"](#).
7. Move A/T selector lever to "R" position.
8. Turn 4WD shift switch to "2WD", "4H" and "2WD" in order.
9. Move A/T selector lever to "P" position.
10. Turn 4WD shift switch to "4H", "2WD" and "4H" in order.
11. Move A/T selector lever to "N" position.
12. Turn 4WD shift switch to "2WD" position.
13. Move A/T selector lever to "P" position.
14. Read the flickering of 4WD warning lamp.

DIAGNOSIS SYSTEM (TRANSFER CONTROL UNIT)

< SYSTEM DESCRIPTION >

[TRANSFER: TX15B]

Refer to "Judgement Self-diagnosis".

Diagnostic Procedure (M/T models)

1. Warm up engine.
2. Turn ignition switch "ON" and "OFF" at least twice, and then turn ignition switch "OFF".
3. Move M/T shift lever to neutral position.
4. Turn 4WD shift switch to "2WD" position.
5. Turn ignition switch "ON". (Do not start engine.)
6. 4WD warning lamp should turn ON.
If 4WD warning lamp does not turn ON, refer to [DLN-73, "Diagnosis Procedure"](#).
7. Move M/T shift lever to any position other than neutral.
8. Turn 4WD shift switch to "2WD", "4H" and "2WD" in order.
9. Move M/T shift lever to neutral position.
10. Turn 4WD shift switch to "4H", "2WD" and "4H" in order.
11. Move M/T shift lever to any position other than neutral.
12. Turn 4WD shift switch to "2WD" position.
13. Move M/T shift lever to neutral position.
14. Read the flickering of 4WD warning lamp.
Refer to "Judgement Self-diagnosis".

Self-diagnosis example

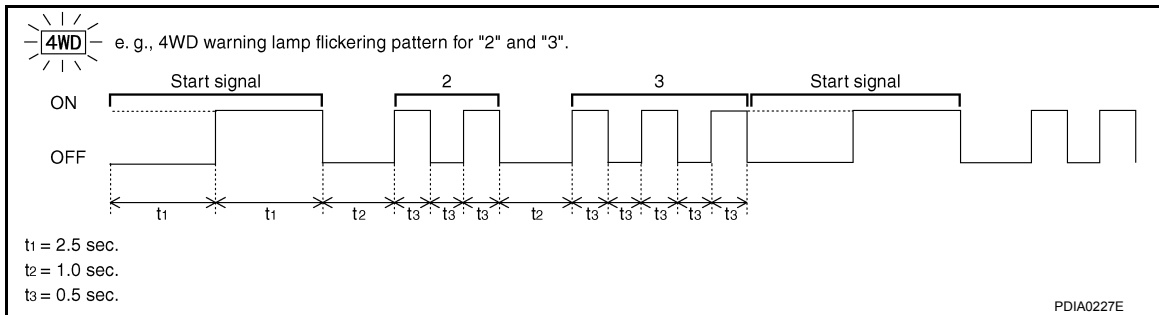

DATA MONITOR

Operation Procedure

1. Connect "CONSULT."
2. Touch "DATA MONITOR".
3. Select from "SELECT MONITOR ITEM", screen of data monitor mode is displayed.

NOTE:

**When malfunction is detected, CONSULT performs REAL-TIME DIAGNOSIS.
Also, any malfunction detected while in this mode will be displayed at real time.**

×: Standard -: Not applicable

Monitor Item (Unit)	Selection			Description
	ECU INPUT SIGNALS	MAIN SIGNALS	SELECTION FROM MENU	
VHCL/S SEN-FR [km/h] or [mph]	×	-	×	Wheel speed calculated by ABS actuator and electric unit (control unit). Signal input with CAN communication line.
VHCL/S SEN-RR [km/h] or [mph]	×	-	×	Wheel speed calculated by TCM. Signal input with CAN communication line.
ENGINE SPEED [rpm]	×	-	×	Engine speed is displayed. Signal input with CAN communication line.
BATTERY VOLT [V]	×	-	×	Power supply voltage for transfer control unit.

DIAGNOSIS SYSTEM (TRANSFER CONTROL UNIT)

< SYSTEM DESCRIPTION >

[TRANSFER: TX15B]

Monitor Item (Unit)	Selection			Description
	ECU INPUT SIGNALS	MAIN SIGNALS	SELECTION FROM MENU	
2WD SWITCH [On/Off]	×	-	×	4WD shift switch signal status is displayed. (4L means 4LO of 4WD shift switch.)
4H SWITCH [On/Off]	×	-	×	
4L SWITCH [On/Off]	×	-	×	
4L POSI SW [On/Off]	×	-	×	4LO switch signal status is displayed.
ATP SWITCH [On/Off]	×	-	×	ATP switch signal status is displayed.
WAIT DETCT SW [On/Off]	×	-	×	Wait detection switch signal status is displayed.
4WD MODE [2H/4H/4L]	-	×	×	Control status of 4WD recognized by transfer control unit. (2WD, 4H or 4LO)
VHCL/S COMP [km/h] or [mph]	-	×	×	Vehicle speed recognized by transfer control unit.
SHIFT ACT 1 [On/Off]	-	×	×	Output condition to actuator motor (clockwise)
SHIFT AC MON1 [On/Off]	-	-	×	Check signal for transfer control unit signal output
SHIFT ACT 2 [On/Off]	-	×	×	Output condition to actuator motor (counterclockwise)
SHIFT AC MON2 [On/Off]	-	-	×	Check signal for transfer control unit signal output
SFT ACT/R MON [On/Off]	-	-	×	Operating condition of actuator motor relay (integrated in transfer control unit)
SHIFT POS SW1 [On/Off]	×	-	×	Condition of actuator position switch 1
SHIFT POS SW2 [On/Off]	×	-	×	Condition of actuator position switch 2
SHIFT POS SW3 [On/Off]	×	-	×	Condition of actuator position switch 3
SHIFT POS SW4 [On/Off]	×	-	×	Condition of actuator position switch 4
4WD FAIL LAMP [On/Off]	-	×	×	Control status of 4WD warning lamp is displayed.
2WD IND [On/Off]	-	-	×	Control status of 4WD shift indicator lamp (rear) is displayed.
4H IND [On/Off]	-	-	×	Control status of 4WD shift indicator lamp (front and center) is displayed.
4L IND [On/Off]	-	-	×	Control status of 4LO indicator lamp is displayed.

A
B
C
DLN
E
F
G
H
I
J
K
L
M
N
O
P

NOISE, VIBRATION AND HARSHNESS (NVH) TROUBLESHOOTING

< SYSTEM DESCRIPTION >

[TRANSFER: TX15B]

NOISE, VIBRATION AND HARSHNESS (NVH) TROUBLESHOOTING

NVH Troubleshooting Chart

INFOID:000000007323856

Use the chart below to help you find the cause of the symptom. The numbers indicate the order of the inspection. If necessary, repair or replace these parts.

Reference page		DLN-93			DLN-106			DLN-106	DLN-106	DLN-106
SUSPECTED PARTS (Possible cause)		TRANSFER FLUID (Level low)	TRANSFER FLUID (Wrong)	TRANSFER FLUID (Level too high)	LIQUID GASKET (Damaged)	O-RING (Worn or damaged)	OIL SEAL (Worn or damaged)	SHIFT FORK (Worn or damaged)	GEAR (Worn or damaged)	BEARING (Worn or damaged)
Symptom	Noise	1	2						3	3
	Transfer fluid leakage		3	1	2	2	2			
	Hard to shift or will not shift		1	1				2		

P1801, P1811 POWER SUPPLY CIRCUIT FOR TRANSFER CONTROL UNIT

< DTC/CIRCUIT DIAGNOSIS >

[TRANSFER: TX15B]

DTC/CIRCUIT DIAGNOSIS

P1801, P1811 POWER SUPPLY CIRCUIT FOR TRANSFER CONTROL UNIT

Description

INFOID:000000007323857

The transfer control unit controls the transfer control device which controls shifts between 4H and 4LO and between 2WD and 4WD. When the vehicle battery is removed, the power supply to the transfer control unit is interrupted, and self-diagnosis memory function is suspended. These DTCs may also set when the power supply voltage for the transfer control unit is abnormally low while driving.

DTC Logic

INFOID:000000007323858

DTC DETECTION LOGIC

DTC	CONSULT	Diagnostic item is detected when...	Reference
[P1801]	*INITIAL START*	Due to removal of battery which cuts off power supply to transfer control unit, self-diagnosis memory function is suspended.	DLN-21
[P1811]	BATTERY VOLTAGE	Power supply voltage for transfer control unit is abnormally low while driving.	

DTC CONFIRMATION PROCEDURE

1. DTC CONFIRMATION PROCEDURE

1. Turn ignition switch ON.
2. Perform self-diagnosis.

Are DTCs "P1801 or P1811 detected?"

- YES >> Perform diagnosis procedure. Refer to [DLN-21, "Diagnosis Procedure"](#).
 NO >> Inspection End.

Diagnosis Procedure

INFOID:000000007323859

Regarding Wiring Diagram information, refer to [DLN-63, "Wiring Diagram"](#).

1. CHECK POWER SUPPLY

1. Turn ignition switch "OFF". (Stay for at least 5 seconds.)
2. Disconnect transfer control unit harness connector.
3. Check voltage between transfer control unit harness connector terminals and ground.

Connector	Terminal	Voltage (Approx.)
M152	19 - Ground	Battery voltage
	25 - Ground	0V
M153	40 - Ground	Battery voltage
	44 - Ground	0V
	45 - Ground	

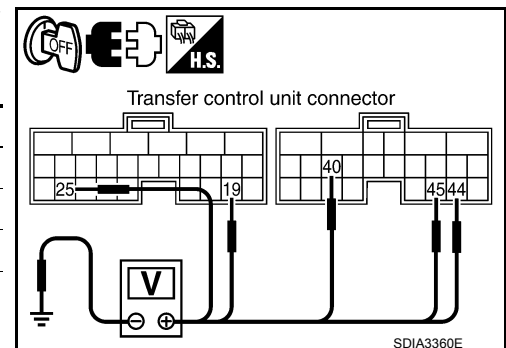

P1801, P1811 POWER SUPPLY CIRCUIT FOR TRANSFER CONTROL UNIT

< DTC/CIRCUIT DIAGNOSIS >

[TRANSFER: TX15B]

- Turn ignition switch "ON". (Do not start engine.)
- Check voltage between transfer control unit harness connector terminals and ground.

Connector	Terminal	Voltage (Approx.)
M152	19 - Ground	Battery voltage
	25 - Ground	
M153	40 - Ground	
	44 - Ground	
	45 - Ground	

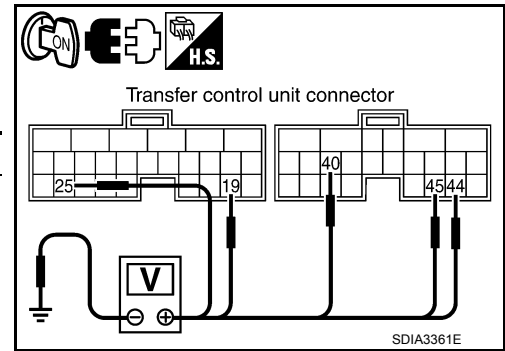

Is there voltage?

YES >> GO TO 2.

NO >> Check the following. If any items are damaged, repair or replace damaged parts.

- 40A fuse (No. J, located in the fuse and fusible link box).
- 10A fuses (No. 18, located in the fuse block (J/B) and Nos. 57 and 58 located in the fuse and relay box).
- Harness for short or open between battery and transfer control unit harness connector M152 terminal 19.
- Harness for short or open between battery and transfer shut off relay 2 harness connector E157 terminal 1 and 3.
- Harness for short or open between battery and transfer shut off relay 1 harness connector E156 terminal 3.
- Harness for short or open between ignition switch and transfer control unit harness connector M152 terminal 25.
- Harness for short or open between ignition switch and transfer shut off relay 1 harness connector E156 terminal 1.
- Harness for short or open between transfer shut off relay 2 harness connector E157 terminal 5 and transfer control unit harness connector M153 terminals 44, 45.
- Harness for short or open between transfer shut off relay 1 harness connector E156 terminal 5 and transfer control unit harness connector M153 terminals 44, 45.
- Harness for short or open between transfer shut off relay 2 harness connector E157 terminal 2 and transfer control unit harness connector M153 terminal 40.
- Harness for open between transfer shut off relay 1 harness connector E156 terminal 2 and ground.
- Battery and ignition switch.
- Transfer shut off relay 1, 2. Refer to [DLN-23. "Component Inspection"](#).

2. CHECK GROUND CIRCUIT

- Turn ignition switch "OFF".
- Disconnect transfer control unit harness connector.
- Check continuity between transfer control unit harness connector M152 terminals 6 (M/T models) and 18, and M153 terminal 32 and ground.

Continuity should exist.

Also check harness for short to power.

Do you have continuity?

YES >> GO TO 3.

NO >> Repair open circuit or short to power in harness or connectors.

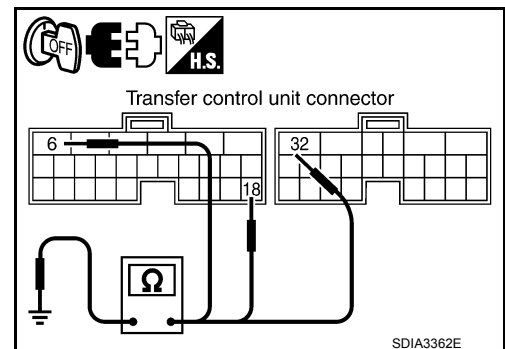

3. CHECK TRANSFER CONTROL UNIT

Check transfer control unit input/output signal. Refer to [DLN-56. "Reference Value"](#).

Are the inspection results normal?

YES >> GO TO 4.

P1801, P1811 POWER SUPPLY CIRCUIT FOR TRANSFER CONTROL UNIT

< DTC/CIRCUIT DIAGNOSIS >

[TRANSFER: TX15B]

NO >> Check transfer control unit pin terminals for damage or loose connection with harness connector.
If any items are damaged, repair or replace damaged parts.

4.CHECK DTC

Drive vehicle and then perform Self-diagnosis.

Do DTCs P1801 or P1811 display?

YES >> Replace transfer control unit. Refer to [DLN-95, "Removal and Installation"](#).

NO >> Inspection End.

Component Inspection

INFOID:000000007323860

1. Turn ignition switch "OFF". (Stay for at least 5 seconds.)
2. Remove transfer shut off relay 1 and transfer shut off relay 2. Refer to [DLN-23, "Component Inspection"](#).
3. Apply 12V direct current between transfer shut off relay terminals 1 and 2.
4. Check continuity between relay terminals 3 and 5.

Condition	Continuity
12V direct current supply between terminals 1 and 2	Yes
OFF	No

5. If inspection results are not normal, replace the transfer shut off relay 1 or 2.

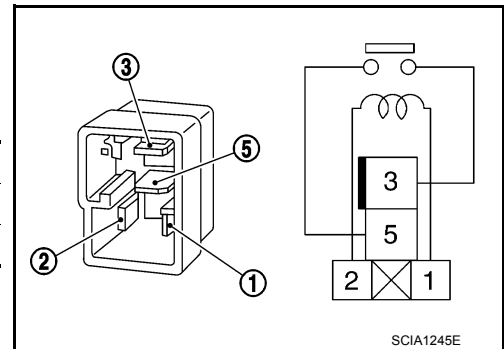

A
B
C
DLN
E
F
G
H
I
J
K
L
M
N
O
P

P1802 – P1804, P1809 TRANSFER CONTROL UNIT

< DTC/CIRCUIT DIAGNOSIS >

[TRANSFER: TX15B]

P1802 – P1804, P1809 TRANSFER CONTROL UNIT

Description

INFOID:000000007323861

The transfer control unit controls the transfer control device which controls shifts between 4H and 4LO and between 2WD and 4WD. A DTC may set when any of the following occur:

- Malfunction is detected in the memory (RAM) system of transfer control unit.
- Malfunction is detected in the memory (ROM) system of transfer control unit.
- Malfunction is detected in the memory (EEPROM) system of transfer control unit.
- AD converter system of transfer control unit is malfunctioning.

DTC Logic

INFOID:000000007323862

DTC DETECTION LOGIC

DTC	CONSULT	Diagnostic item is detected when...	Reference
[P1802]	CONTROL UNIT 1	Malfunction is detected in the memory (RAM) system of transfer control unit.	DLN-24
[P1803]	CONTROL UNIT 2	Malfunction is detected in the memory (ROM) system of transfer control unit.	
[P1804]	CONTROL UNIT 3	Malfunction is detected in the memory (EEPROM) system of transfer control unit.	
[P1809]	CONTROL UNIT 4	AD converter system of transfer control unit is malfunctioning.	

DTC CONFIRMATION PROCEDURE

1. DTC CONFIRMATION PROCEDURE

1. Turn ignition switch ON.
2. Perform self-diagnosis.

Are DTCs "P1802 - P1804 or P1809 detected?"

- YES >> Perform diagnosis procedure. Refer to [DLN-24, "Diagnosis Procedure"](#).
NO >> Inspection End.

Diagnosis Procedure

INFOID:000000007323863

1. INSPECTION START

Do you have CONSULT?

YES or NO

- YES >> GO TO 2.
NO >> GO TO 3.

2. PERFORM SELF-DIAGNOSIS (WITH CONSULT)

1. Turn ignition switch "ON".
2. Select "SELF-DIAG RESULTS" mode for "ALL MODE AWD/4WD" with CONSULT.
3. Touch "ERASE".
4. Turn ignition switch "OFF" and wait at least 10 seconds.
5. Perform the self-diagnosis again.

Is the "CONTROL UNIT 1 [P1802]", "CONTROL UNIT 2 [P1803]", "CONTROL UNIT 3 [P1804]" or CONTROL UNIT 4 [P1809]" displayed?

- YES >> Replace transfer control unit. Refer to [DLN-95, "Removal and Installation"](#).
NO >> Inspection End.

3. PERFORM SELF-DIAGNOSIS (WITHOUT CONSULT)

1. Perform the self-diagnosis and then erase self-diagnostic results. Refer to [DLN-17, "CONSULT Function \(ALL MODE AWD/4WD\)"](#).
2. Perform the self-diagnosis again.

P1802 – P1804, P1809 TRANSFER CONTROL UNIT

< DTC/CIRCUIT DIAGNOSIS >

[TRANSFER: TX15B]

Do the self-diagnostic results indicate AD converter?

YES >> Replace transfer control unit. Refer to [DLN-95, "Removal and Installation"](#).

NO >> Inspection End.

A

B

C

DLN

E

F

G

H

I

J

K

L

M

N

O

P

P1807 VEHICLE SPEED SENSOR (A/T)

< DTC/CIRCUIT DIAGNOSIS >

[TRANSFER: TX15B]

P1807 VEHICLE SPEED SENSOR (A/T)

Description

INFOID:000000007323864

The transmission control module (TCM) transmits the output shaft revolution signal via CAN communication to Transfer control unit. DTC P1807 will set when a malfunction is detected in the output shaft revolution signal or an improper signal is input while driving.

DTC Logic

INFOID:000000007323865

DTC DETECTION LOGIC

DTC	CONSULT	Diagnostic item is detected when...	Reference
[P1807]	VHCL SPEED SEN·AT	<ul style="list-style-type: none">Malfunction is detected in output shaft revolution signal that is output from TCM through CAN communication.Improper signal is input while driving.	DLN-26

DTC CONFIRMATION PROCEDURE

1. DTC CONFIRMATION PROCEDURE

1. Turn ignition switch ON.
2. Perform self-diagnosis.

Is DTC P1807 detected?

- YES >> Perform diagnosis procedure. Refer to [DLN-26. "Diagnosis Procedure"](#).
NO >> Inspection End.

Diagnosis Procedure

INFOID:000000007323866

1. CHECK DTC WITH TCM

Perform self-diagnosis with TCM. Refer to [DLN-17. "CONSULT Function \(ALL MODE AWD/4WD\)"](#).

Is any malfunction detected by self-diagnosis?

- YES >> Check the malfunctioning system.
NO >> GO TO 2.

2. CHECK TRANSFER CONTROL UNIT

Check transfer control unit input/output signal. Refer to [DLN-56. "Reference Value"](#).

Are the inspection results normal?

- YES >> GO TO 3.
NO >> Check transfer control unit pin terminals for damage or loose connection with harness connector.
If any items are damaged, repair or replace damaged parts.

3. CHECK DTC

Drive vehicle and then perform Self-diagnosis.

Is DTC P1807 displayed?

- YES >> Perform self-diagnosis with TCM again.
NO >> Inspection End.

P1808 VEHICLE SPEED SENSOR (ABS)

< DTC/CIRCUIT DIAGNOSIS >

[TRANSFER: TX15B]

P1808 VEHICLE SPEED SENSOR (ABS)

Description

INFOID:000000007323867

The ABS actuator and electric unit (control unit) transmits a vehicle speed signal via CAN communication to the transfer control unit. DTC P1808 sets when a malfunction is detected in the vehicle speed signal that is output from the ABS actuator and electric unit (control unit) or an improper signal is input while driving.

DTC Logic

INFOID:000000007323868

DTC DETECTION LOGIC

DTC	CONSULT	Diagnostic item is detected when...	Reference
[P1808]	VHCL SPEED SEN-ABS	<ul style="list-style-type: none">Malfunction is detected in vehicle speed signal that is output from ABS actuator and electric unit (control unit) through CAN communication.Improper signal is input while driving.	DLN-27

DTC CONFIRMATION PROCEDURE

1. DTC CONFIRMATION PROCEDURE

1. Turn ignition switch ON.
2. Perform self-diagnosis.

Is DTC "P1808 displayed?"

- YES >> Perform diagnosis procedure. Refer to [DLN-27. "Diagnosis Procedure"](#).
NO >> Inspection End.

Diagnosis Procedure

INFOID:000000007323869

1. CHECK DTC WITH ABS ACTUATOR AND ELECTRIC UNIT (CONTROL UNIT)

Perform self-diagnosis with ABS actuator and electric unit (control unit) for specific BRC system type.

Is any malfunction detected by self-diagnosis?

- YES >> Check the malfunctioning system.
NO >> GO TO 2.

2. CHECK TRANSFER CONTROL UNIT

Check transfer control unit input/output signal. Refer to [DLN-56. "Reference Value"](#).

Are the inspection results normal?

- YES >> GO TO 3.
NO >> Check transfer control unit pin terminals for damage or loose connection with harness connector.
If any items are damaged, repair or replace damaged parts.

3. CHECK DTC

Drive vehicle and then perform Self-diagnosis.

Is DTC P1808 displayed?

- YES >> Perform self-diagnosis with ABS actuator and electric unit (control unit) for specific BRC system type.
NO >> Inspection End.

P1810 4 LO SWITCH

< DTC/CIRCUIT DIAGNOSIS >

[TRANSFER: TX15B]

P1810 4 LO SWITCH

Description

INFOID:000000007323870

The 4LO switch detects that the transfer case is in 4LO range. DTC P1810 will set when an improper signal from the 4LO switch is input due to an open or short circuit.

DTC Logic

INFOID:000000007323871

DTC DETECTION LOGIC

DTC	CONSULT	Diagnostic item is detected when...	Reference
[P1810]	4L POSI SW TF	Improper signal from 4LO switch is input due to open or short circuit.	DLN-28

DTC CONFIRMATION PROCEDURE

1. DTC CONFIRMATION PROCEDURE

1. Turn ignition switch ON.
2. Perform self-diagnosis.

Is DTC P1810 displayed?

- YES >> Perform diagnosis procedure. Refer to [DLN-28, "Diagnosis Procedure"](#).
 NO >> Inspection End.

Diagnosis Procedure

INFOID:000000007323872

Regarding Wiring Diagram information, refer to [DLN-63, "Wiring Diagram"](#).

1. CHECK 4LO POSITION SWITCH SIGNAL

With CONSULT

1. Start engine.
2. Select "DATA MONITOR" mode for "ALL MODE AWD/4WD" with CONSULT.
3. Read out the value of "4L POSI SW".

Condition		Display value
<ul style="list-style-type: none"> • Vehicle stopped • Engine running • A/T selector lever "N" position • Brake pedal depressed 	4WD shift switch: 4LO	ON
	Except the above	OFF

Without CONSULT

1. Start engine.
2. Check voltage between transfer control unit harness connector terminal and ground.

Connector	Terminal	Condition	Voltage (Approx.)
M152	24 - Ground	<ul style="list-style-type: none"> • Vehicle stopped • Engine running • A/T selector lever "N" position • Brake pedal depressed 	0V
		Except the above	Battery voltage

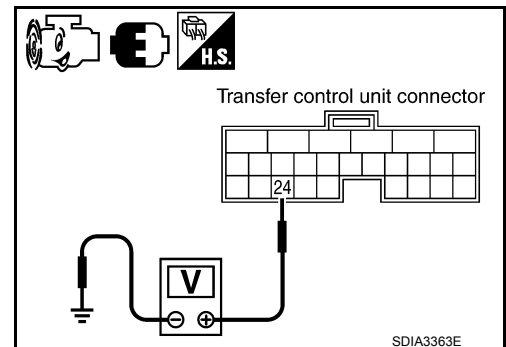

Are the inspection results normal?

P1810 4 LO SWITCH

[TRANSFER: TX15B]

< DTC/CIRCUIT DIAGNOSIS >

- YES >> GO TO 5.
- NO >> GO TO 2.

2.CHECK HARNESS BETWEEN TRANSFER CONTROL UNIT AND 4LO SWITCH

1. Turn ignition switch "OFF". (Stay for at least 5 seconds.)
2. Disconnect transfer control unit harness connector and the 4LO switch harness connector.
3. Check continuity between transfer control unit harness connector M152 terminal 24 and 4LO switch harness connector F60 terminal 13.

Continuity should exist.

Also check harness for short to ground and short to power.

Is there continuity?

- YES >> GO TO 3.
- NO >> Repair or replace damaged parts.

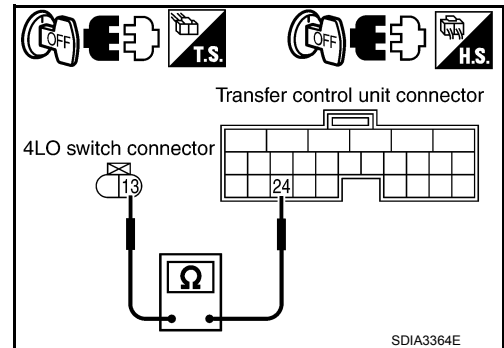

3.CHECK GROUND CIRCUIT

1. Turn ignition switch "OFF". (Stay for at least 5 seconds.)
2. Disconnect 4LO switch harness connector.
3. Check continuity between 4LO switch harness connector F60 terminal 12 and ground.

Continuity should exist.

Also check harness for short to power.

Is there continuity?

- YES >> GO TO 4.
- NO >> Repair open circuit or short to power in harness or connectors.

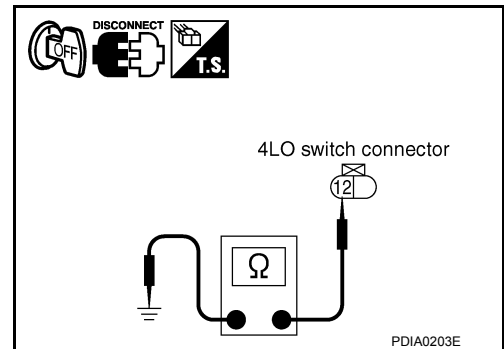

4.CHECK 4LO SWITCH

1. Turn ignition switch "OFF". (Stay for at least 5 seconds.)
2. Disconnect 4LO switch harness connector.
3. Remove 4LO switch. Refer to [DLN-13. "Component Parts Location"](#).
4. Push and release 4LO switch and check continuity between 4LO switch terminals 12 and 13.

Terminal	Condition	Continuity
12 - 13	Push 4LO switch	Yes
	Release 4LO switch	No

Are the inspection results normal?

- YES >> GO TO 5.
- NO >> Replace 4LO switch.

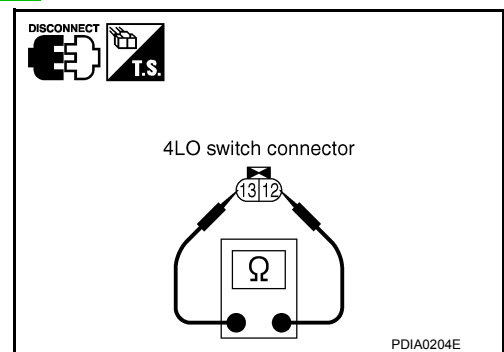

5.CHECK TRANSFER CONTROL UNIT

Check transfer control unit input/output signal. Refer to [DLN-56. "Reference Value"](#).

Are the inspection results normal?

- YES >> GO TO 6.
- NO >> Check transfer control unit pin terminals for damage or loose connection with harness connector. If any items are damaged, repair or replace damaged parts.

6.CHECK DTC

Drive the vehicle and then perform self-diagnosis.

Is DTC P1810 displayed?

A
B
C
DLN
E
F
G
H
I
J
K
L
M
N
O
P

P1810 4 LO SWITCH

[TRANSFER: TX15B]

< DTC/CIRCUIT DIAGNOSIS >

- YES >> Replace transfer control unit. Refer to [DLN-13, "Component Parts Location"](#).
NO >> Inspection End.

Component Inspection

INFOID:000000007323873

1. Turn ignition switch "OFF". (Stay for at least 5 seconds.)
2. Disconnect 4LO switch harness connector.
3. Remove 4LO switch. Refer to [DLN-13, "Component Parts Location"](#).
4. Push and release 4LO switch and check continuity between 4LO switch terminals 12 and 13.

Terminal	Condition	Continuity
12 - 13	Push 4LO switch	Yes
	Release 4LO switch	No

5. If the inspection results are not normal replace the 4LO switch.

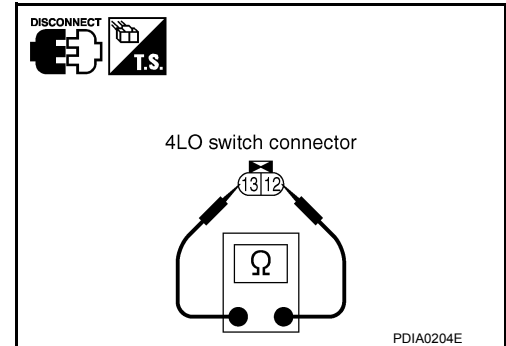

P1813 4WD SHIFT SWITCH

< DTC/CIRCUIT DIAGNOSIS >

[TRANSFER: TX15B]

P1813 4WD SHIFT SWITCH

Description

INFOID:000000007323874

The 4WD shift switch allows the driver to select 2WD or 4WD and 4H or 4LO. DTC P1813 will set if more than two switch inputs are simultaneously detected by the transfer control unit due to a short circuit in the 4WD shift switch.

DTC Logic

INFOID:000000007323875

DTC DETECTION LOGIC

DTC	CONSULT	Diagnostic item is detected when...	Reference
[P1813]	4WD MODE SW	More than two switch inputs are simultaneously detected due to short circuit of 4WD shift switch.	DLN-31

DTC CONFIRMATION PROCEDURE

1. DTC CONFIRMATION PROCEDURE

1. Turn ignition switch ON.
2. Perform self-diagnosis.

Is DTC P1813 displayed?

- YES >> Perform diagnosis procedure. Refer to [DLN-31, "Diagnosis Procedure"](#).
 NO >> Inspection End.

Diagnosis Procedure

INFOID:000000007323876

Regarding Wiring Diagram information, refer to [DLN-63, "Wiring Diagram"](#).

1. CHECK 4WD SHIFT SWITCH SIGNAL

With CONSULT

1. Turn ignition switch "ON".
2. Select "DATA MONITOR" mode for "ALL MODE AWD/4WD" with CONSULT.
3. Read out ON/OFF switching action of the "2WD SWITCH", "4H SWITCH", "4L SWITCH" with operating 4WD shift switch.

Without CONSULT

1. Turn ignition switch "ON".
2. Check voltage between transfer control unit harness connector terminals and ground.

Connector	Terminal	Condition	Voltage (Approx.)
M152	14 - Ground	4WD shift switch: 2WD	Battery voltage
		4WD shift switch: 4H and 4LO	0V
	15 - Ground	4WD shift switch: 4H	Battery voltage
		4WD shift switch: 2WD and 4LO	0V
	16 - Ground	4WD shift switch: 4LO	Battery voltage
		4WD shift switch: 2WD and 4H	0V

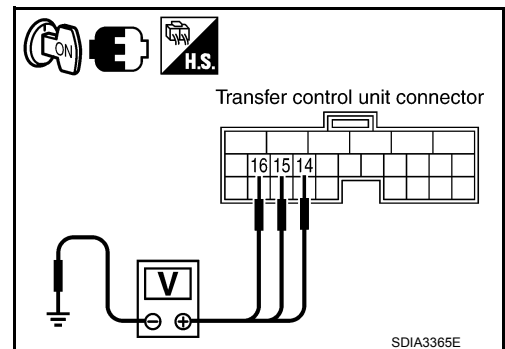

Are the inspection results normal?

- YES >> GO TO 5.

P1813 4WD SHIFT SWITCH

[TRANSFER: TX15B]

< DTC/CIRCUIT DIAGNOSIS >

NO >> GO TO 2.

2. CHECK 4WD SHIFT SWITCH POWER SUPPLY CIRCUIT

1. Turn ignition switch "OFF". (Stay for at least 5 seconds.)
2. Disconnect 4WD shift switch harness connector.
3. Check voltage between 4WD shift switch harness connector terminal 1 and ground.

Connector	Terminal	Voltage (Approx.)
M141	1 - Ground	0V

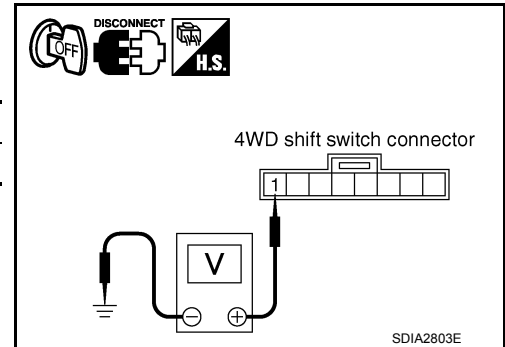

4. Turn ignition switch "ON". (Do not start engine.)
5. Check voltage between 4WD shift switch harness connector terminal 1 and ground.

Connector	Terminal	Voltage (Approx.)
M141	1 - Ground	Battery voltage

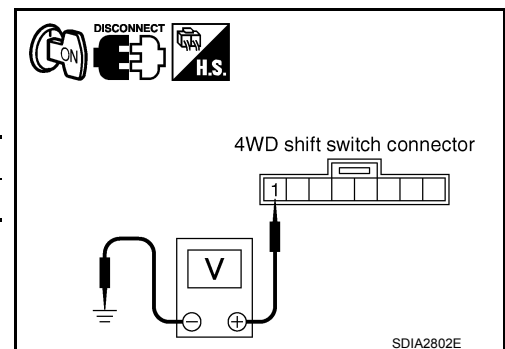

Is there voltage?

YES >> GO TO 3.

- NO >> 1. Check harness for short or open between 4WD shift switch harness connector terminal 1 and transfer shut off relay 2 harness connector E157 terminal 5 and 10A fuse (No. 58 located in the fuse and relay box). If any items are damaged, repair or replace damaged parts.

2. Perform trouble diagnosis for power supply circuit. Refer to [DLN-21, "Diagnosis Procedure"](#).

3. CHECK HARNESS BETWEEN 4WD SHIFT SWITCH AND TRANSFER CONTROL UNIT

1. Turn ignition switch "OFF". (Stay for at least 5 seconds.)
2. Disconnect transfer control unit harness connector and the 4WD shift switch harness connector.
3. Check continuity between the following terminals.
 - Transfer control unit harness connector M152 terminal 14 and 4WD shift switch harness connector M141 terminal 3.
 - Transfer control unit harness connector M152 terminal 15 and 4WD shift switch harness connector M141 terminal 5.
 - Transfer control unit harness connector M152 terminal 16 and 4WD shift switch harness connector M141 terminal 6.

Continuity should exist.

Also check harness for short to ground and short to power.

Is there continuity?

YES >> GO TO 4.

NO >> Repair or replace damaged parts.

4. CHECK 4WD SHIFT SWITCH

1. Turn ignition switch "OFF". (Stay for at least 5 seconds.)
2. Remove 4WD shift switch harness connector.

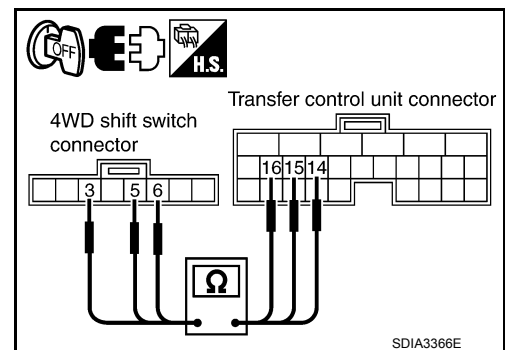

P1813 4WD SHIFT SWITCH

[TRANSFER: TX15B]

< DTC/CIRCUIT DIAGNOSIS >

- Operate 4WD shift switch and check continuity between 4WD shift switch terminals.

Terminal	Condition	Continuity
1 - 3	4WD shift switch: 2WD	Yes
	4WD shift switch: 4H and 4LO	No
1 - 5	4WD shift switch: 4H	Yes
	4WD shift switch: 2WD and 4LO	No
1 - 6	4WD shift switch: 4LO	Yes
	4WD shift switch: 2WD and 4H	No

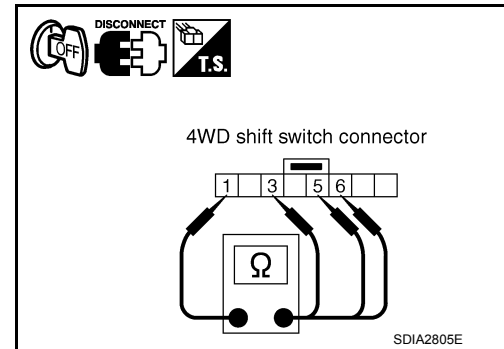

Are the inspection results normal?

- YES >> GO TO 5.
- NO >> Replace 4WD shift switch.

5.CHECK TRANSFER CONTROL UNIT

Check transfer control unit input/output signal. Refer to [DLN-56. "Reference Value"](#).

Are the inspection results normal?

- YES >> GO TO 6.
- NO >> Check transfer control unit pin terminals for damage or loose connection with harness connector. If any items are damaged, repair or replace damaged parts.

6.CHECK DTC

Drive the vehicle and then perform self-diagnosis.

Is DTC P1813 displayed?

- YES >> Replace transfer control unit. Refer to [DLN-95. "Removal and Installation"](#).
- NO >> Inspection End.

Component Inspection

INFOID:000000007323877

- Turn ignition switch "OFF". (Stay for at least 5 seconds.)
- Remove 4WD shift switch harness connector.
- Operate 4WD shift switch and check continuity between 4WD shift switch terminals.

Terminal	Condition	Continuity
1 - 3	4WD shift switch: 2WD	Yes
	4WD shift switch: 4H and 4LO	No
1 - 5	4WD shift switch: 4H	Yes
	4WD shift switch: 2WD and 4LO	No
1 - 6	4WD shift switch: 4LO	Yes
	4WD shift switch: 2WD and 4H	No

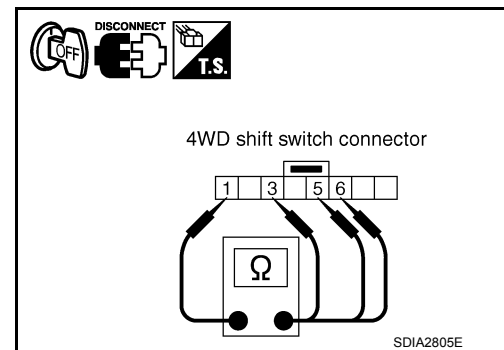

- If the inspection results are abnormal replace the 4WD shift switch.

P1814 WAIT DETECTION SWITCH

< DTC/CIRCUIT DIAGNOSIS >

[TRANSFER: TX15B]

P1814 WAIT DETECTION SWITCH

Description

INFOID:000000007323878

The wait detection switch detects if the transfer case is in 4WD. DTC P1814 will set if an improper signal from the wait detection switch is input due to open or short circuit.

DTC Logic

INFOID:000000007323879

DTC DETECTION LOGIC

DTC	CONSULT	Diagnostic item is detected when...	Reference
[P1814]	4WD DETECT SWITCH	Improper signal from wait detection switch is input due to open or short circuit.	DLN-34

DTC CONFIRMATION PROCEDURE

1. DTC CONFIRMATION PROCEDURE

1. Turn ignition switch ON.
2. Perform self-diagnosis.

Is DTC P1814 detected?

- YES >> Perform diagnosis procedure. Refer to [DLN-34, "Diagnosis Procedure"](#).
 NO >> Inspection End.

Diagnosis Procedure

INFOID:000000007323880

Regarding Wiring Diagram information, refer to [DLN-63, "Wiring Diagram"](#).

1. CHECK WAIT DETECTION SWITCH SIGNAL

With CONSULT

1. Start engine.
2. Select "DATA MONITOR" mode for "ALL MODE AWD/4WD" with CONSULT.
3. Read out the value of "WAIT DETCT SW".

Condition	Display value
<ul style="list-style-type: none"> • Vehicle stopped • Engine running 	4WD shift switch: 4H and 4LO ON
<ul style="list-style-type: none"> • A/T selector lever "N" position • Brake pedal depressed 	4WD shift switch: 2WD OFF

Without CONSULT

1. Start engine.
2. Check voltage between transfer control unit harness connector terminal and ground.

Connector	Terminal	Condition	Voltage (Approx.)
M152	17 - Ground	<ul style="list-style-type: none"> • Vehicle stopped • Engine running 	4WD shift switch : 4H and 4LO 0V
		<ul style="list-style-type: none"> • A/T selector lever "N" position • Brake pedal depressed 	4WD shift switch: 2WD Battery voltage

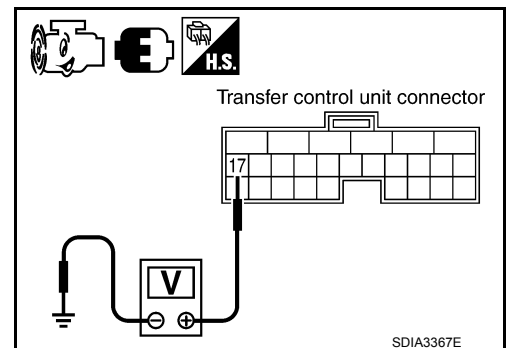

Are the inspection results normal?

P1814 WAIT DETECTION SWITCH

< DTC/CIRCUIT DIAGNOSIS >

[TRANSFER: TX15B]

- YES >> GO TO 5.
- NO >> GO TO 2.

2.CHECK HARNESS BETWEEN TRANSFER CONTROL UNIT AND WAIT DETECTION SWITCH

1. Turn ignition switch "OFF". (Stay for at least 5 seconds.)
2. Disconnect transfer control unit harness connector and the wait detection switch harness connector.
3. Check continuity between transfer control unit harness connector M152 terminal 17 and wait detection switch harness connector F59 terminal 10.

Continuity should exist.

Also check harness for short to ground and short to power.

Is there continuity?

- YES >> GO TO 3.
- NO >> Repair or replace damaged parts.

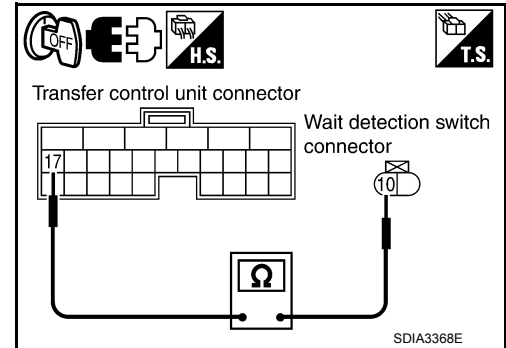

3.CHECK GROUND CIRCUIT

1. Turn ignition switch "OFF". (Stay for at least 5 seconds.)
2. Disconnect wait detection switch harness connector.
3. Check continuity between wait detection switch harness connector F59 terminal 11 and ground.

Continuity should exist.

Also check harness for short to power.

Is there continuity?

- YES >> GO TO 4.
- NO >> Repair open circuit or short to power in harness or connectors.

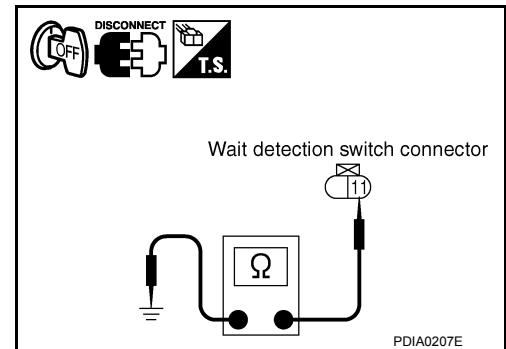

4.CHECK WAIT DETECTION SWITCH

1. Turn ignition switch "OFF". (Stay for at least 5 seconds.)
2. Disconnect wait detection switch harness connector.
3. Remove wait detection switch. Refer to [DLN-13. "Component Parts Location"](#).
4. Push and release wait detection switch and check continuity between wait detection switch terminals 10 and 11.

Terminal	Condition	Continuity
10 - 11	Push wait detection switch	Yes
	Release wait detection switch	No

Are the inspection results normal?

- YES >> GO TO 5.
- NO >> Replace wait detection switch.

5.CHECK TRANSFER CONTROL UNIT

Check transfer control unit input/output signal. Refer to [DLN-56. "Reference Value"](#).

Are the inspection results normal?

- YES >> GO TO 6.
- NO >> Check transfer control unit pin terminals for damage or loose connection with harness connector. If any items are damaged, repair or replace damaged parts.

6.CHECK DTC

Drive the vehicle and then perform self-diagnosis.

Is DTC P1814 displayed?

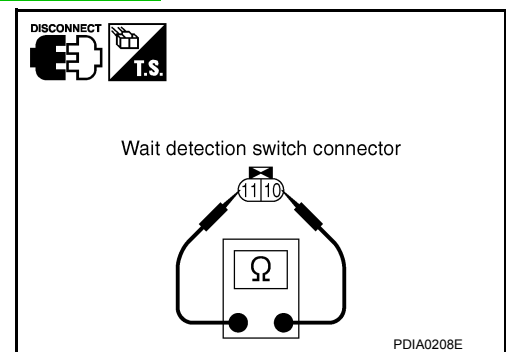

A
B
C
DLN
E
F
G
H
I
J
K
L
M
N
O
P

P1814 WAIT DETECTION SWITCH

< DTC/CIRCUIT DIAGNOSIS >

[TRANSFER: TX15B]

- YES >> Replace transfer control unit. Refer to [DLN-95. "Removal and Installation"](#).
- NO >> Inspection End.

Component Inspection

INFOID:000000007323881

1. Turn ignition switch "OFF". (Stay for at least 5 seconds.)
2. Disconnect wait detection switch harness connector.
3. Remove wait detection switch. Refer to [DLN-13. "Component Parts Location"](#).
4. Push and release wait detection switch and check continuity between wait detection switch terminals 10 and 11.

Terminal	Condition	Continuity
10 - 11	Push wait detection switch	Yes
	Release wait detection switch	No

5. If the inspection results are abnormal replace the wait detection switch.

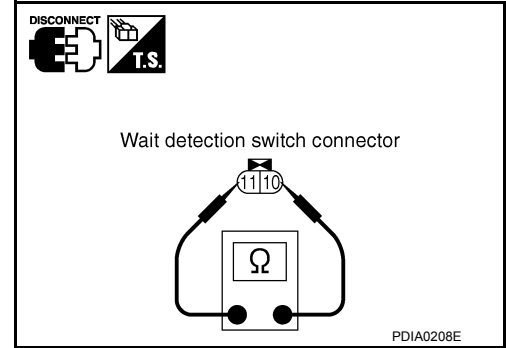

P1816 PNP SWITCH (A/T)

< DTC/CIRCUIT DIAGNOSIS >

[TRANSFER: TX15B]

P1816 PNP SWITCH (A/T)

Description

INFOID:000000007323882

The transmission range switch transmits the A/T position indicator signal (transmission range switch signal) via CAN communication to the transfer control unit. DTC P1816 will set when the transmission range switch signal is malfunctioning or there is a communication error.

DTC Logic

INFOID:000000007323883

DTC DETECTION LOGIC

DTC	CONSULT	Diagnostic item is detected when...	Reference
[P1816]	PNP SW/CIRC	When transmission range switch signal is malfunction or communication error between the control units.	DLN-37

DTC CONFIRMATION PROCEDURE

1. DTC CONFIRMATION PROCEDURE

1. Turn ignition switch ON.
2. Perform self-diagnosis.

Is DTC P1816 displayed?

- YES >> Perform diagnosis procedure. Refer to [DLN-37. "Diagnosis Procedure"](#).
NO >> Inspection End.

Diagnosis Procedure

INFOID:000000007323884

1. CHECK DTC WITH TCM

Perform self-diagnosis with TCM. Refer to [DLN-17. "CONSULT Function \(ALL MODE AWD/4WD\)"](#).

Is any malfunction detected by self-diagnosis?

- YES >> Check the malfunctioning system.
NO >> GO TO 2.

2. CHECK TRANSFER CONTROL UNIT

Check transfer control unit input/output signal. Refer to [DLN-56. "Reference Value"](#).

Is the inspection result normal?

- YES >> GO TO 3.
NO >> Check transfer control unit pin terminals for damage or loose connection with harness connector.
If any items are damaged, repair or replace damaged parts.

3. CHECK DTC

Drive the vehicle and then perform self-diagnosis.

Is DTC P1816 displayed?

- YES >> Perform self-diagnosis with TCM again.
NO >> Inspection End.

P1816 PNP SWITCH (M/T)

< DTC/CIRCUIT DIAGNOSIS >

[TRANSFER: TX15B]

P1816 PNP SWITCH (M/T)

Description

INFOID:000000007323885

The M/T PNP switch signals neutral position to the transfer control unit. DTC P1816 will set when the M/T PNP switch signal is malfunctioning.

DTC Logic

INFOID:000000007323886

DTC DETECTION LOGIC

DTC	CONSULT	Diagnostic item is detected when...	Reference
[P1816]	PNP SW/CIRC	When M/T PNP switch signal is malfunction.	DLN-38

DTC CONFIRMATION PROCEDURE

1. DTC CONFIRMATION PROCEDURE

1. Turn ignition switch ON.
2. Perform self-diagnosis.

Is DTC P1816 displayed?

- YES >> Perform diagnosis procedure. Refer to [DLN-38, "Diagnosis Procedure"](#).
NO >> Inspection End.

Diagnosis Procedure

INFOID:000000007323887

Regarding Wiring Diagram information, refer to [DLN-63, "Wiring Diagram"](#).

1. CHECK PARK/NEUTRAL POSITION SWITCH SIGNAL

1. Turn ignition switch ON.
2. Check voltage between transfer control unit harness connector M152 terminal 33 and ground.

Connector	Terminal	Condition	Voltage (Approx.)
M152	33 - Ground	Ignition switch: ON	0V
		Except the above	Battery voltage

Is the inspection result normal?

- YES >> GO TO 5.
NO >> GO TO 2.

2. CHECK HARNESS BETWEEN TRANSFER CONTROL UNIT AND PARK/NEUTRAL POSITION SWITCH

1. Turn ignition switch OFF. (Stay for at least 5 seconds.)
2. Disconnect transfer control unit harness connector and the park/neutral position switch harness connector.

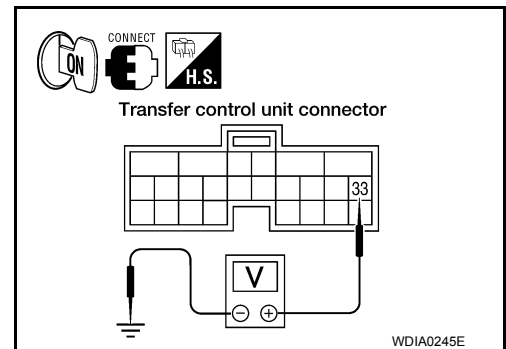

P1816 PNP SWITCH (M/T)

[TRANSFER: TX15B]

< DTC/CIRCUIT DIAGNOSIS >

3. Check continuity between transfer control unit harness connector M152 terminal 33 and park/neutral position switch harness connector F66 terminal 1.

Continuity should exist.

Also check harness for short to ground and short to power.

Is the inspection result normal?

- YES >> GO TO 3.
NO >> Repair or replace damaged parts.

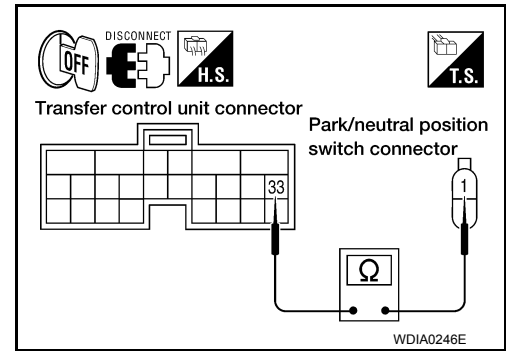

3. CHECK GROUND CIRCUIT

1. Turn ignition switch OFF. (Stay for at least 5 seconds.)
2. Disconnect park/neutral position switch harness connector.
3. Check continuity between park/neutral position switch harness connector F66 terminal 2 and ground.

Continuity should exist.

Also check harness for short to power.

Is the inspection result normal?

- YES >> GO TO 4.
NO >> Repair open circuit or short to power in harness or connectors.

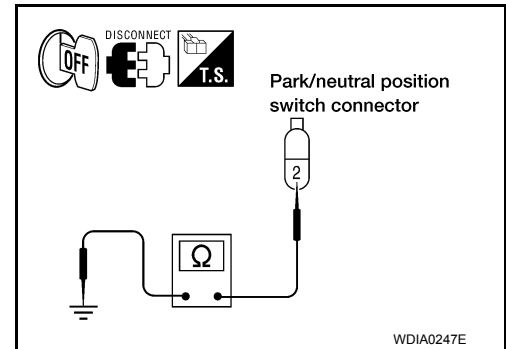

4. CHECK PARK/NEUTRAL POSITION SWITCH

1. Turn ignition switch OFF. (Stay for at least 5 seconds.)
2. Remove park/neutral position switch. Refer to [DLN-13, "Component Parts Location"](#).
3. Push and release park/neutral position switch and check continuity between park/neutral position switch terminals 1 and 2.

Terminal	Condition	Continuity
1 - 2	Push park/neutral position switch	Yes
	Release park/neutral position switch	No

Is the inspection result normal?

- YES >> GO TO 5.
NO >> Replace park/neutral position switch. Refer to [DLN-13, "Component Parts Location"](#).

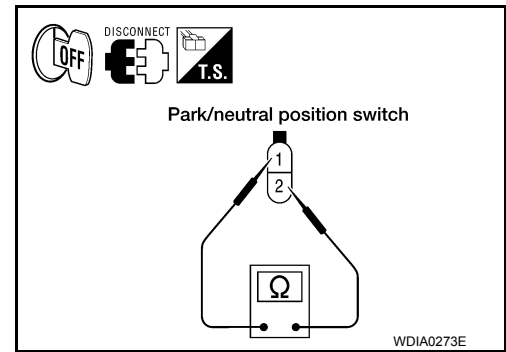

5. CHECK TRANSFER CONTROL UNIT

Check transfer control unit input/output signal. Refer to [DLN-56, "Reference Value"](#).

Is the inspection result normal?

- YES >> Inspection End.
NO >> Check transfer control unit pin terminals for damage or loose connection with harness connector. If any items are damaged, repair or replace damaged parts.

Component Inspection

INFOID:000000007323888

1. Turn ignition switch "OFF". (Stay for at least 5 seconds.)
2. Disconnect neutral position switch harness connector.
3. Remove neutral position switch. Refer to [DLN-13, "Component Parts Location"](#).

P1816 PNP SWITCH (M/T)

[TRANSFER: TX15B]

< DTC/CIRCUIT DIAGNOSIS >

4. Push and release neutral position switch and check continuity between neutral position switch terminals 1 and 2.

Terminal	Condition	Continuity
1 - 2	Push neutral position switch	Yes
	Release neutral position switch	No

5. If NG, replace the neutral position switch.

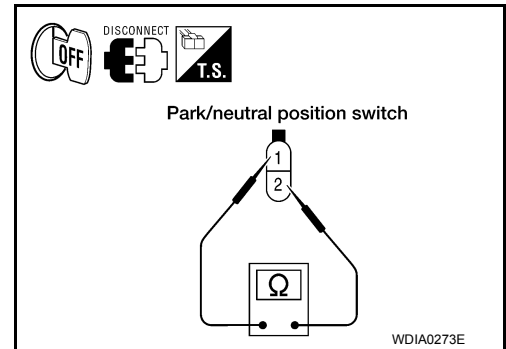

P1817 ACTUATOR MOTOR

< DTC/CIRCUIT DIAGNOSIS >

[TRANSFER: TX15B]

P1817 ACTUATOR MOTOR

Description

INFOID:000000007323889

The actuator motor receives signals from the transfer control unit and controls shift rods which shift the transfer case. DTC P1817 will set when any of the following occur:

- Motor does not operate properly due to open or short circuit in actuator motor.
- Malfunction is detected in the actuator motor. (When 4WD shift switch is operated and actuator motor does not operate)
- Malfunction is detected in transfer shift high relay or transfer shift low relay.

DTC Logic

INFOID:000000007323890

DTC DETECTION LOGIC

DTC	CONSULT	Diagnostic item is detected when...	Reference
[P1817]	SHIFT ACTUATOR	<ul style="list-style-type: none">• Motor does not operate properly due to open or short circuit in actuator motor.• Malfunction is detected in the actuator motor. (When 4WD shift switch is operated and actuator motor is not operated)• Malfunction is detected in transfer shift high relay or transfer shift low relay.	DLN-41

DTC CONFIRMATION PROCEDURE

1. DTC CONFIRMATION PROCEDURE

1. Turn ignition switch ON.
2. Perform self-diagnosis.

Is DTC P1817 detected?

YES >> Perform diagnosis procedure. Refer to [DLN-41, "Diagnosis Procedure"](#).

NO >> Inspection End.

Diagnosis Procedure

INFOID:000000007323891

Regarding Wiring Diagram information, refer to [DLN-63, "Wiring Diagram"](#).

1. CHECK ACTUATOR MOTOR SIGNAL

With CONSULT

1. Start engine.
2. Select "DATA MONITOR" mode for "ALL MODE AWD/4WD" with CONSULT.
3. Read out the value of "SHIFT ACT1", "SHIFT AC MON1", "SHIFT ACT2", "SHIFT AC MON2".

P1817 ACTUATOR MOTOR

< DTC/CIRCUIT DIAGNOSIS >

[TRANSFER: TX15B]

Monitored item	Condition	Display value
SHIFT ACT1	4WD shift switch: 2WD to 4H or 4H to 4LO or 2WD to 4LO	ON
	Except the above	OFF
SHIFT AC MON1	4WD shift switch: 2WD to 4H or 4H to 4LO or 2WD to 4LO	ON
	Except the above	OFF
SHIFT ACT2	4WD shift switch: 4LO to 4H or 4H to 2WD or 4LO to 2WD	ON
	Except the above	OFF
SHIFT AC MON2	4WD shift switch: 4LO to 4H or 4H to 2WD or 4LO to 2WD	ON
	Except the above	OFF

⊗ Without CONSULT

1. Start engine.
2. Depress brake pedal and stop vehicle.
3. Set A/T selector lever to "N" position.
4. Check voltage between transfer control unit harness connector terminal and ground.

Connector	Terminal	Condition	Voltage (Approx.)
M153	28 - Ground	When 4WD shift switch is operated (While actuator motor is operating.)	Battery voltage → 0V
		When 4WD shift switch is not operated	0V
	31 - Ground	Always	0V
M153	42 - Ground	<ul style="list-style-type: none"> • Vehicle stopped • Engine running 4WD shift switch: 2WD to 4H or 4H to 4LO or 2WD to 4LO	0V
		<ul style="list-style-type: none"> • A/T selector lever "N" position • Brake pedal depressed Except the above	Battery voltage
M153	47 - Ground	4WD shift switch: 2WD to 4H or 4H to 4LO or 2WD to 4LO	Battery voltage → 0V
		Except the above	0V
	48 - Ground	4WD shift switch: 4LO to 4H or 4H to 2WD or 4LO to 2WD	Battery voltage → 0V
		Except the above	0V
50 - Ground	4WD shift switch: 4LO to 4H or 4H to 2WD or 4LO to 2WD	0V	
	Except the above	Battery voltage	

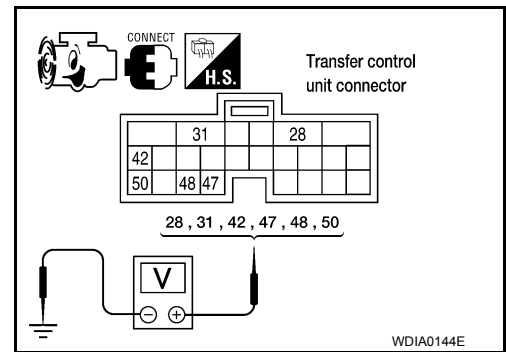

P1817 ACTUATOR MOTOR

[TRANSFER: TX15B]

< DTC/CIRCUIT DIAGNOSIS >

Are the inspection results normal?

- YES >> GO TO 9.
- NO >> GO TO 2.

2. CHECK ACTUATOR MOTOR POWER SUPPLY CIRCUIT

1. Turn ignition switch "OFF". (Stay for at least 5 seconds.)
2. Disconnect transfer control unit harness connector.
3. Check voltage between transfer control unit harness connector terminal 27 and ground.

Connector	Terminal	Voltage (Approx.)
M153	27 - Ground	0V

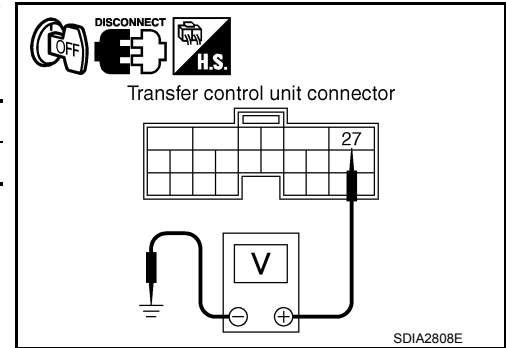

4. Turn ignition switch "ON".
5. Check voltage between transfer control unit harness connector terminal 27 and ground.

Connector	Terminal	Voltage (Approx.)
M153	27 - Ground	Battery voltage

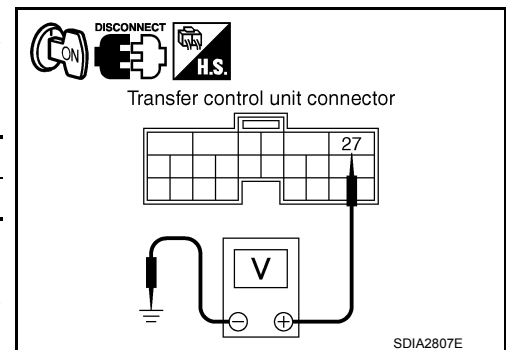

Are the inspection results normal?

- YES >> GO TO 3.
- NO >> 1. Check harness for short or open between transfer control unit harness connector M153 terminal 27 and transfer shut off relay 2 harness connector E157 terminal 5 and 10A fuse (No. 57, located in the fuse and relay block). If any items are damaged, repair or replace damaged parts.
- 2. Perform trouble diagnosis for power supply circuit. Refer to [DLN-21, "Diagnosis Procedure"](#).

3. CHECK TRANSFER RELAY POWER SUPPLY CIRCUIT

1. Turn ignition switch "OFF". (Stay for at least 5 seconds.)
2. Remove transfer shift high relay and transfer shift low relay. Refer to [DLN-13, "Component Parts Location"](#).
3. Check voltage between transfer shift high and low relay connector terminals and ground.

Connector	Terminal	Voltage (Approx.)
E46	2 - Ground	0V
E47	2 - Ground	0V

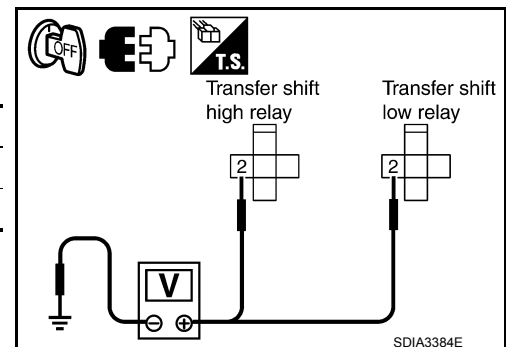

A
B
C
DLN
E
F
G
H
I
J
K
L
M
N
O
P

P1817 ACTUATOR MOTOR

< DTC/CIRCUIT DIAGNOSIS >

[TRANSFER: TX15B]

- Turn ignition switch "ON". (Do not start engine.)
- Check voltage between transfer shift high and low relay connector terminals and ground.

Connector	Terminal	Voltage (Approx.)
E46	2 - Ground	Battery voltage
E47	2 - Ground	Battery voltage

Are the inspection results normal?

YES >> GO TO 4.

NO >> Check the following. If any items are damaged, repair or replace damaged parts.

- Harness for short or open between transfer control unit harness connector terminal 27 and transfer shift high relay harness connector E46 terminal 2.
- Harness for short or open between transfer control unit harness connector terminal 27 and transfer shift low relay harness connector terminal E47 terminal 2.

4. CHECK TRANSFER RELAY

- Turn ignition switch "OFF". (Stay for at least 5 seconds.)
- Remove transfer shift high relay and transfer shift low relay.
- Apply 12V direct current between transfer shift high and low relay terminals 1 and 2.
- Check continuity between relay terminals 3 and 4, 3 and 5.

Terminal	Condition	Continuity
3 - 4	12V direct current supply between terminals 1 and 2	No
	OFF	Yes
3 - 5	12V direct current supply between terminals 1 and 2	Yes
	OFF	No

Are the inspection results normal?

YES >> GO TO 5.

NO >> Replace the transfer shift high or low relay.

5. CHECK (1): HARNESS BETWEEN TRANSFER CONTROL UNIT AND TRANSFER SHIFT RELAY

- Turn ignition switch "OFF". (Stay for at least 5 seconds.)
- Disconnect transfer control unit harness connector.
- Remove transfer shift high relay and transfer shift low relay.
- Check continuity between the following terminals.
 - Transfer control unit harness connector M153 terminal 42 and transfer shift high relay harness connector E46 terminal 1.
 - Transfer control unit harness connector M153 terminal 50 and transfer shift low relay harness connector E47 terminal 1.

Continuity should exist.

Also check harness for short to ground and short to power.

Is there continuity?

YES >> GO TO 6.

NO >> Repair or replace damaged parts.

6. CHECK (2): HARNESS BETWEEN TRANSFER CONTROL UNIT AND TRANSFER SHIFT RELAY

- Turn ignition switch "OFF". (Stay for at least 5 seconds.)
- Disconnect transfer control unit harness connector.
- Remove transfer shift high relay and transfer shift low relay.

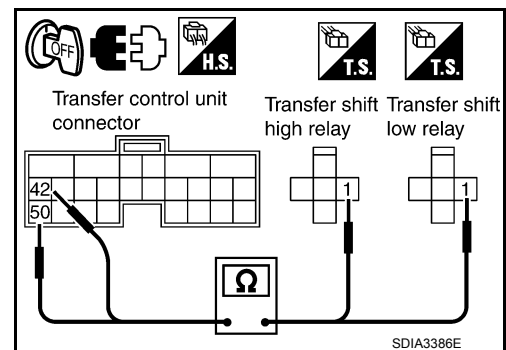
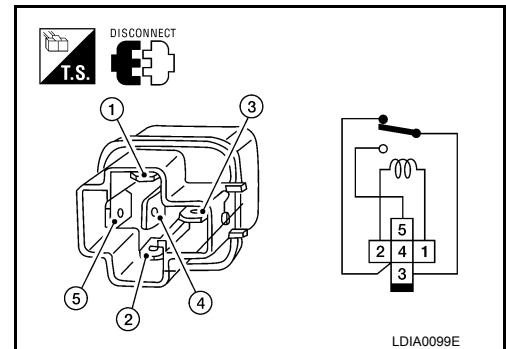
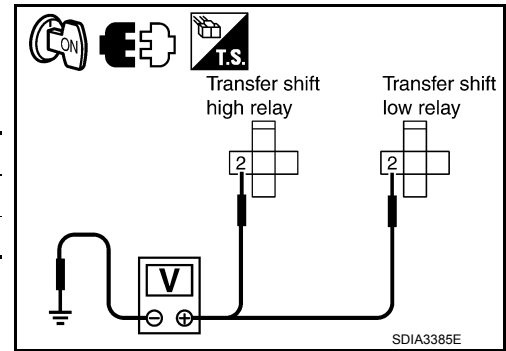

P1817 ACTUATOR MOTOR

< DTC/CIRCUIT DIAGNOSIS >

[TRANSFER: TX15B]

4. Check continuity between the following terminals.
 - Transfer control unit harness connector M153 terminal 28 and transfer shift high relay harness connector E46 terminal 5.
 - Transfer control unit harness connector M153 terminal 28 and transfer shift low relay harness connector E47 terminal 5.
 - Transfer control unit harness connector M153 terminal 31 and transfer shift high relay harness connector E46 terminal 4.
 - Transfer control unit harness connector M153 terminal 31 and transfer shift low relay harness connector E47 terminal 4.

Continuity should exist.

Also check harness for short to ground and short to power.

Is there continuity?

YES >> GO TO 7.

NO >> Repair or replace damaged parts.

7. CHECK ACTUATOR MOTOR OPERATION CIRCUIT

1. Turn ignition switch "OFF". (Stay for at least 5 seconds.)
2. Disconnect transfer control unit harness connector and the transfer control device (actuator motor) harness connector.
3. Check continuity between the following terminals.
 - Transfer control unit harness connector M153 terminal 47 and transfer control device (actuator motor) harness connector F58 terminal 23.
 - Transfer control unit harness connector M153 terminal 48 and transfer control device (actuator motor) harness connector F58 terminal 24.

- Transfer control device (actuator motor) harness connector F58 terminal 24 and transfer shift high relay harness connector E46 terminal 3.
- Transfer control device (actuator motor) harness connector F58 terminal 23 and transfer shift low relay harness connector E47 terminal 3.

Continuity should exist.

Also check harness for short to ground and short to power.

Is there continuity?

YES >> GO TO 8.

NO >> Repair or replace damaged parts.

8. CHECK ACTUATOR MOTOR

1. Remove transfer control device. Refer to [DLN-100, "Removal and Installation"](#).

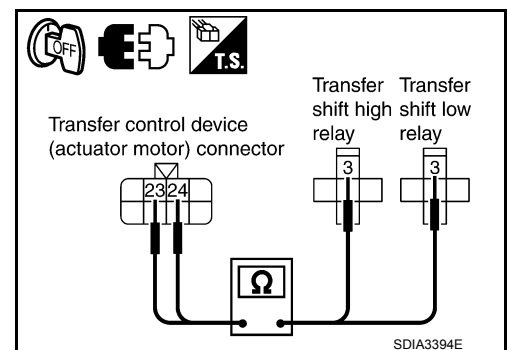
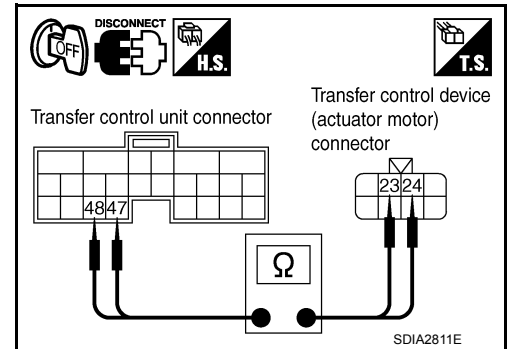
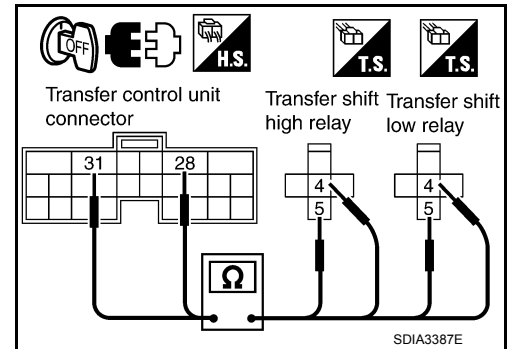

P1817 ACTUATOR MOTOR

[TRANSFER: TX15B]

< DTC/CIRCUIT DIAGNOSIS >

- Check operation by applying battery voltage to transfer control device (actuator motor) terminals 23 and 24.

CAUTION:

Be careful not to overheat the harness.

Terminal	Actuator motor
24 (Battery voltage) - 23 (Ground)	Clockwise rotate
23 (Battery voltage) - 24 (Ground)	Counterclockwise rotate

Does actuator motor rotate?

- YES >> GO TO 9.
 NO >> Replace transfer control device (actuator motor).

9. CHECK TRANSFER CONTROL UNIT

Check transfer control unit input/output signal. Refer to [DLN-56, "Reference Value"](#).

Are the inspection results normal?

- YES >> GO TO 10.
 NO >> Check transfer control unit pin terminals for damage or loose connection with harness connector.
 If any items are damaged, repair or replace damaged parts.

10. CHECK DTC

Perform the self-diagnosis, after driving a vehicle for a while.

Is DTC P1817 displayed?

- YES >> Replace transfer control unit. Refer to [DLN-95, "Removal and Installation"](#).
 NO >> Inspection End.

Component Inspection

INFOID:000000007323892

ACTUATOR MOTOR

- Remove transfer control device. Refer to [DLN-100, "Removal and Installation"](#).
- Check operation by applying battery voltage to transfer control device (actuator motor) terminals 23 and 24.

CAUTION:

Be careful not to overheat the harness.

Terminal	Actuator motor
24 (Battery voltage) - 23 (Ground)	Clockwise rotate
23 (Battery voltage) - 24 (Ground)	Counterclockwise rotate

- If the inspection results are abnormal replace the transfer control device (actuator motor).

TRANSFER RELAY

- Turn ignition switch "OFF". (Stay for at least 5 seconds.)
- Remove transfer shift high relay and transfer shift low relay 2. Refer to [DLN-13, "Component Parts Location"](#).
- Apply 12V direct current between transfer shift high and low relay terminals 1 and 2.

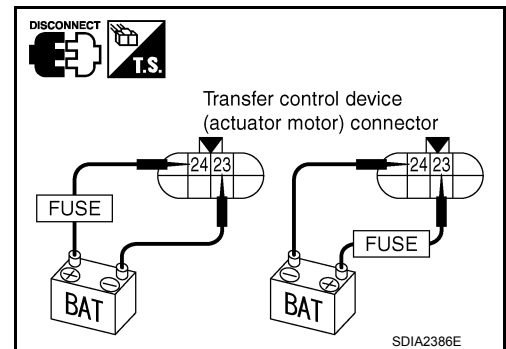
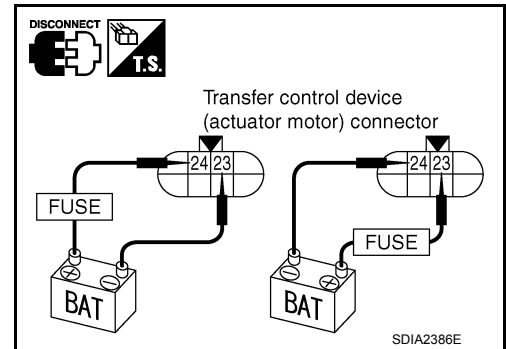

P1817 ACTUATOR MOTOR

< DTC/CIRCUIT DIAGNOSIS >

[TRANSFER: TX15B]

4. Check continuity between relay terminals 3 and 4, and 3 and 5.

Terminal	Condition	Continuity
3 - 4	12V direct current supply between terminals 1 and 2	No
	OFF	Yes
3 - 5	12V direct current supply between terminals 1 and 2	Yes
	OFF	No

5. If the inspection results are abnormal replace the transfer shift high or low relay.

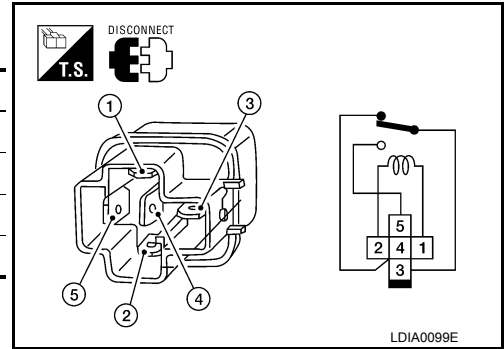

A
B
C

DLN

E
F
G
H
I
J
K
L
M
N
O
P

P1818 ACTUATOR POSITION SWITCH

< DTC/CIRCUIT DIAGNOSIS >

[TRANSFER: TX15B]

P1818 ACTUATOR POSITION SWITCH

Description

INFOID:000000007323893

The actuator position switch detects the current actuator motor range. DTC P1818 will set if either of the following occur:

- Improper signal from actuator position switch is input due to open or short circuit.
- Malfunction is detected in actuator position switch.

DTC Logic

INFOID:000000007323894

DTC DETECTION LOGIC

DTC	CONSULT	Diagnostic item is detected when...	Reference
[P1818]	SHIFT ACT POSI SW	<ul style="list-style-type: none">• Improper signal from actuator position switch is input due to open or short circuit.• Malfunction is detected in actuator position switch.	DLN-48

DTC CONFIRMATION PROCEDURE

1. DTC CONFIRMATION PROCEDURE

1. Turn ignition switch ON.
2. Perform self-diagnosis.

Is DTC P1818 detected?

- YES >> Perform diagnosis procedure. Refer to [DLN-48, "Diagnosis Procedure"](#).
NO >> Inspection End.

Diagnosis Procedure

INFOID:000000007323895

Regarding Wiring Diagram information, refer to [DLN-63, "Wiring Diagram"](#).

1. CHECK ACTUATOR POSITION SWITCH SIGNAL

Ⓜ With CONSULT

1. Start engine.
2. Depress brake pedal and stop vehicle.
3. Set A/T selector lever to "N" position.
4. Select "DATA MONITOR" mode for "ALL MODE AWD/4WD" with CONSULT.
5. Read out the value of "SHIFT POS SW1", "SHIFT POS SW2", "SHIFT POS SW3", "SHIFT POS SW4".

Monitored item	Condition	Display value
SHIFT POS SW1	4WD shift switch: 2WD and 4LO	ON
	4WD shift switch: 4H	OFF
SHIFT POS SW2	4WD shift switch: 4LO	ON
	4WD shift switch: 2WD and 4H	OFF
SHIFT POS SW3	4WD shift switch: 2WD and 4H	ON
	4WD shift switch: 4LO	OFF
SHIFT POS SW4	4WD shift switch: 4H and 4LO	ON
	4WD shift switch: 2WD	OFF

ⓧ Without CONSULT

1. Start engine.

P1818 ACTUATOR POSITION SWITCH

[TRANSFER: TX15B]

< DTC/CIRCUIT DIAGNOSIS >

2. Depress brake pedal and stop vehicle.
3. Set A/T selector lever to "N" position.
4. Check voltage between transfer control unit harness connector terminal and ground.

Connector	Terminal	Condition	Voltage (Approx.)
M152	10 - Ground	4WD shift switch: 2WD and 4LO	0V
		4WD shift switch: 4H	Battery voltage
	11 - Ground	4WD shift switch: 4LO	0V
		4WD shift switch: 2WD and 4H	Battery voltage
	12 - Ground	4WD shift switch: 2WD and 4H	0V
		4WD shift switch: 4LO	Battery voltage
	13 - Ground	4WD shift switch: 4H and 4LO	0V
		4WD shift switch: 2WD	Battery voltage

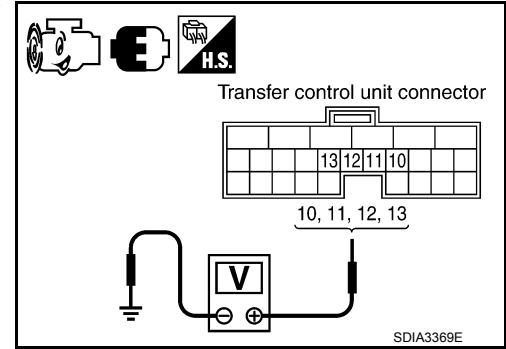

Are the inspection results normal?

- YES >> GO TO 4.
NO >> GO TO 2.

2. CHECK HARNESS BETWEEN TRANSFER CONTROL UNIT AND ACTUATOR POSITION SWITCH

1. Turn ignition switch "OFF". (Stay for at least 5 seconds.)
2. Disconnect transfer control unit harness connector and the transfer control device (actuator position switch) harness connector.
3. Check continuity between the following terminals.
 - Transfer control unit harness connector M152 terminal 10 and transfer control device (actuator position switch) harness connector F58 terminal 26.
 - Transfer control unit harness connector M152 terminal 11 and transfer control device (actuator position switch) harness connector F58 terminal 20.
 - Transfer control unit harness connector M152 terminal 12 and transfer control device (actuator position switch) harness connector F58 terminal 21.
 - Transfer control unit harness connector M152 terminal 13 and transfer control device (actuator position switch) harness connector F58 terminal 25.

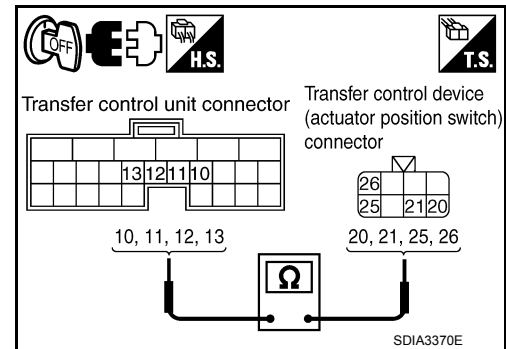

Continuity should exist.

Also check harness for short to ground and short to power.

Is there continuity?

- YES >> GO TO 3.
NO >> Repair or replace damaged parts.

3. CHECK GROUND CIRCUIT

1. Turn ignition switch "OFF". (Stay for at least 5 seconds.)

P1818 ACTUATOR POSITION SWITCH

< DTC/CIRCUIT DIAGNOSIS >

[TRANSFER: TX15B]

2. Check continuity between transfer control device (actuator position switch) harness connector F58 terminal 22 and ground.

Continuity should exist.

Also check harness for short to power.

Is there continuity?

YES >> GO TO 4.

NO >> Repair open circuit or short to power in harness or connectors.

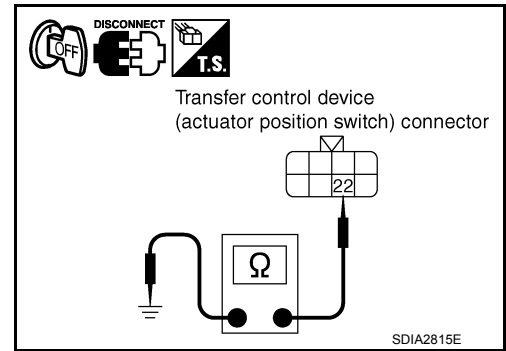

4. CHECK TRANSFER CONTROL UNIT

Check transfer control unit input/output signal. Refer to [DLN-56, "Reference Value"](#).

Are the inspection results normal?

YES >> GO TO 5.

NO >> Check transfer control unit pin terminals for damage or loose connection with harness connector. If any items are damaged, repair or replace damaged parts.

5. CHECK DTC

Perform the self-diagnosis, after driving a vehicle for a while.

Is DTC P1818 displayed?

YES >> Replace transfer control device. Refer to [DLN-100, "Removal and Installation"](#).

NO >> Inspection End.

P1819 TRANSFER CONTROL DEVICE

< DTC/CIRCUIT DIAGNOSIS >

[TRANSFER: TX15B]

P1819 TRANSFER CONTROL DEVICE

Description

INFOID:000000007323896

The transfer control device integrates the actuator motor and actuator position switch. DTC P1819 will set if either of the following conditions exist:

- Malfunction occurs in transfer control device drive circuit.
- Malfunction is detected in transfer shut off relay 1 and transfer shut off relay 2.

DTC Logic

INFOID:000000007323897

DTC DETECTION LOGIC

DTC	CONSULT	Diagnostic item is detected when...	Reference
[P1819]	SHIFT ACT CIR	<ul style="list-style-type: none"> • Malfunction is detected in transfer shut off relay 1 and transfer shut off relay 2. • Malfunction occurs in transfer control device drive circuit. 	DLN-51

DTC CONFIRMATION PROCEDURE

1. DTC CONFIRMATION PROCEDURE

1. Turn ignition switch ON.
2. Perform self-diagnosis.

Is DTC P1819 detected?

- YES >> Perform diagnosis procedure. Refer to [DLN-51. "Diagnosis Procedure"](#).
- NO >> Inspection End.

Diagnosis Procedure

INFOID:000000007323898

Regarding Wiring Diagram information, refer to [DLN-63. "Wiring Diagram"](#).

1. CHECK POWER SUPPLY

1. Turn ignition switch "OFF". (Stay for at least 5 seconds.)
2. Disconnect transfer control unit harness connector.
3. Check voltage between transfer control unit harness connector terminal and ground.

Connector	Terminal	Voltage (Approx.)
M152	25 - Ground	0V
M153	27 - Ground	

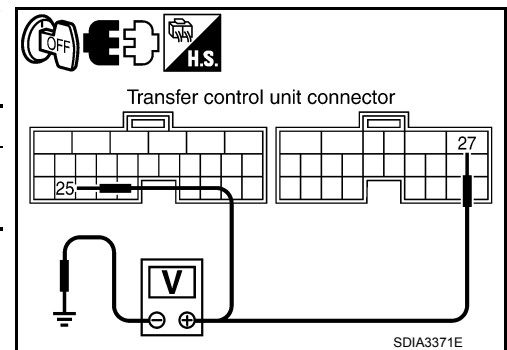

P1819 TRANSFER CONTROL DEVICE

[TRANSFER: TX15B]

< DTC/CIRCUIT DIAGNOSIS >

- Turn ignition switch "ON". (Do not start engine.)
- Check voltage between transfer control unit harness connector terminals and ground.

Connector	Terminal	Voltage (Approx.)
M152	25 - Ground	Battery voltage
M153	27 - Ground	

Are the inspection results normal?

YES >> GO TO 2.

NO >> Check the following. If any items are damaged, repair or replace damaged parts.

- 10A fuse (No. 57, located in the fuse and relay box).
- 40A fuse (No. J, located in the fuse and fusible link box).
- Harness for short or open between battery and transfer shut off relay 1 harness connector E156 terminal 3.
- Harness for short or open between transfer control unit harness connector M153 terminal 27 and transfer shut off relay 1 harness connector E156 terminal 5.
- Harness for short or open between ignition switch and transfer shut off relay 1 harness connector E156 terminal 1.
- Harness for short or open between transfer shut off relay 1 harness connector E156 terminal 2 and ground.
- Harness for short or open between ignition switch and transfer control unit harness connector M152 terminal 25.
- Battery and ignition switch.
- Transfer shut off relay 1. Refer to [DLN-23, "Component Inspection"](#).

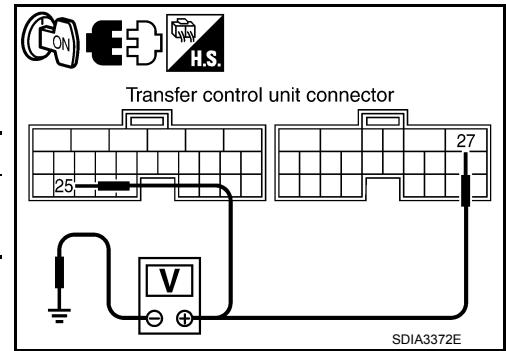

2. CHECK GROUND CIRCUIT

- Turn ignition switch "OFF".
- Disconnect transfer control unit harness connector.
- Check continuity between transfer control unit harness connector M153 terminal 32 and ground.

Continuity should exist.

Also check harness for short to power.

Is there continuity?

YES >> GO TO 3.

NO >> Repair open circuit or short to power in harness or connectors.

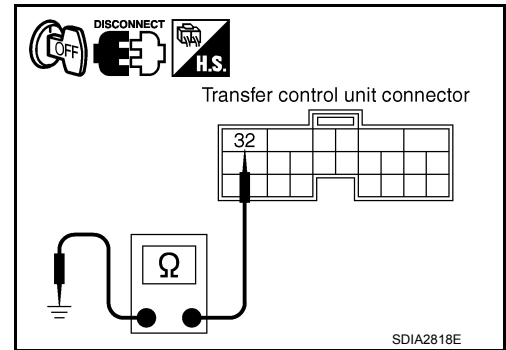

3. CHECK POWER SUPPLY SIGNAL

- Turn ignition switch "OFF". (Stay for at least 5 seconds.)
- Connect transfer control unit harness connector.
- Check voltage between transfer control unit harness connector terminal and ground.

Connector	Terminal	Voltage (Approx.)
M153	40 - Ground	Battery voltage

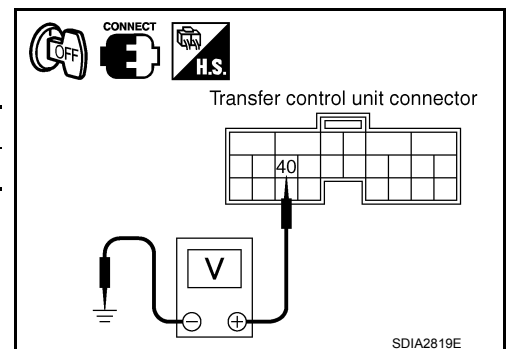

P1819 TRANSFER CONTROL DEVICE

< DTC/CIRCUIT DIAGNOSIS >

[TRANSFER: TX15B]

- Turn ignition switch "ON". (Do not start engine.)
- Check voltage between transfer control unit harness connector terminal and ground.

Connector	Terminal	Voltage (Approx.)
M153	40 - Ground	0V

Are the inspection results normal?

YES >> GO TO 4.

NO >> Check the following. If any items are damaged, repair or replace damaged parts.

- Harness for short or open between battery and transfer shut off relay 2 harness connector E157 terminal 1.
- Harness for short or open between transfer shut off relay 2 harness connector E157 terminal 2 and transfer control unit harness connector M153 terminal 40.
- Transfer shut off relay 2.

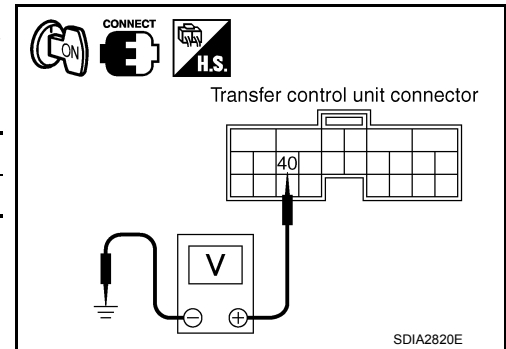

4. CHECK TRANSFER CONTROL UNIT

Check transfer control unit input/output signal. Refer to [DLN-56, "Reference Value"](#).

Are the inspection results normal?

YES >> GO TO 5 (With CONSULT) or GO TO 6 (Without CONSULT).

NO >> Check transfer control unit pin terminals for damage or loose connection with harness connector. If any items are damaged, repair or replace damaged parts.

5. PERFORM SELF-DIAGNOSIS (WITH CONSULT)

With CONSULT

- Turn ignition switch "ON". (Do not start engine.)
- Select "SELF-DIAG RESULTS" mode for "ALL MODE AWD/4WD" with CONSULT.
- Touch "ERASE".
- Turn ignition switch "OFF" and wait at least 10 seconds.
- Perform the self-diagnosis again.

Is the "SHIFT ACT CIR [P1819]" displayed?

YES >> Replace transfer control unit. Refer to [DLN-95, "Removal and Installation"](#).

NO >> Inspection End.

6. PERFORM SELF-DIAGNOSIS (WITHOUT CONSULT)

Without CONSULT

- Perform the self-diagnosis and then erase self-diagnostic results. Refer to [DLN-17, "CONSULT Function \(ALL MODE AWD/4WD\)"](#).
- Perform the self-diagnosis again.

Do the self-diagnostic results indicate transfer control device?

YES >> Replace transfer control unit. Refer to [DLN-95, "Removal and Installation"](#).

NO >> Inspection End.

P1820 ENGINE SPEED SIGNAL

< DTC/CIRCUIT DIAGNOSIS >

[TRANSFER: TX15B]

P1820 ENGINE SPEED SIGNAL

Description

INFOID:000000007323899

The ECM transmits the engine speed signal via CAN communication to the transfer control unit. DTC P1820 will set when either of the following occur:

- Malfunction is detected in engine speed signal that is output from the ECM.
- Improper signal is input while driving.

DTC Logic

INFOID:000000007323900

DTC DETECTION LOGIC

DTC	CONSULT	Diagnostic item is detected when...	Reference
[P1820]	ENGINE SPEED SIG	<ul style="list-style-type: none">• Malfunction is detected in engine speed signal that is output from ECM through CAN communication.• Improper signal is input while driving.	DLN-54

DTC CONFIRMATION PROCEDURE

1. DTC CONFIRMATION PROCEDURE

1. Turn ignition switch ON.
2. Perform self-diagnosis.

Is DTC P1820 detected?

- YES >> Perform diagnosis procedure. Refer to [DLN-54, "Diagnosis Procedure"](#).
NO >> Inspection End.

Diagnosis Procedure

INFOID:000000007323901

1. CHECK DTC WITH ECM

Perform self-diagnosis with ECM. Refer to [EC-499, "CONSULT Function"](#).

Is any malfunction detected by self-diagnosis?

- YES >> Check the malfunctioning system.
NO >> GO TO 2.

2. CHECK TRANSFER CONTROL UNIT

Check transfer control unit input/output signal. Refer to [DLN-56, "Reference Value"](#).

Are the inspection results normal?

- YES >> GO TO 3.
NO >> Check transfer control unit pin terminals for damage or loose connection with harness connector.
If any items are damaged, repair or replace damaged parts.

3. CHECK DTC

Perform the self-diagnosis, after driving a vehicle for a while.

Is DTC P1820 displayed?

- YES >> Perform self-diagnosis with ECM again.
NO >> Inspection End.

U1010 CONTROL UNIT (CAN)

< DTC/CIRCUIT DIAGNOSIS >

[TRANSFER: TX15B]

U1010 CONTROL UNIT (CAN)

Description

INFOID:000000007323902

CAN (Controller Area Network) is a serial communication line for real time application. It is an on-vehicle multiplex communication line with high data communication speed and excellent error detection ability. Many electronic control units are equipped onto a vehicle, and each control unit shares information and links with other control units during operation (not independent). In CAN communication, control units are connected with 2 communication lines (CAN-H line, CAN-L line) allowing a high rate of information transmission with less wiring. Each control unit communicate data but selectively reads required data only.

DTC Logic

INFOID:000000007323903

DTC DETECTION LOGIC

DTC	Display item	Malfunction detected condition	Possible cause
U1010	CONTROL UNIT (CAN)	Detecting error during the initial diagnosis of CAN controller of transfer control unit.	Malfunction of transfer control unit

DTC CONFIRMATION PROCEDURE

1. DTC REPRODUCTION PROCEDURE

With CONSULT

1. Turn the ignition switch ON.
2. Perform transfer control unit self-diagnosis. Refer to [DLN-17. "CONSULT Function \(ALL MODE AWD/4WD\)"](#).

Is DTC U1010 detected?

- YES >> Proceed to diagnosis procedure. Refer to [DLN-55. "Diagnosis Procedure"](#).
NO >> Inspection End.

Diagnosis Procedure

INFOID:000000007323904

1. CHECK TRANSFER CONTROL UNIT CONNECTOR

Check transfer control unit connectors for disconnection and deformation.

Is the inspection result normal?

- YES >> Replace transfer control unit. Refer to [DLN-95. "Removal and Installation"](#).
NO >> Repair or replace parts as necessary.

TRANSFER CONTROL UNIT

< ECU DIAGNOSIS INFORMATION >

[TRANSFER: TX15B]

ECU DIAGNOSIS INFORMATION

TRANSFER CONTROL UNIT

Reference Value

INFOID:000000007323905

VALUE ON THE DIAGNOSIS TOOL

CONSULT data monitor item

Monitored item [Unit]	Content	Condition	Display value	
VHCL/S SEN·FR [km/h] or [mph]	Wheel speed (Front wheel)	Vehicle stopped	0 km/h (0 mph)	
		Vehicle running CAUTION: Check air pressure of tire under standard condition.	Approximately equal to the indication on speedometer (Inside of ±10%)	
VHCL/S SEN·RR [km/h] or [mph]	Wheel speed (Rear wheel)	Vehicle stopped	0 km/h (0 mph)	
		Vehicle running CAUTION: Check air pressure of tire under standard condition.	Approximately equal to the indication on speedometer (Inside of ±10%)	
ENGINE SPEED [rpm]	Engine speed	Engine stopped (Engine speed: Less than 400 rpm)	0 rpm	
		Engine running (Engine speed: 400 rpm or more)	Approximately equal to the indication on tachometer	
BATTERY VOLT [V]	Power supply voltage for transfer control unit	Ignition switch: ON	Battery voltage	
2WD SWITCH [On/Off]	Input condition from 4WD shift switch	4WD shift switch: 2WD	On	
		4WD shift switch: 4H and 4LO	Off	
4H SWITCH [On/Off]	Input condition from 4WD shift switch	4WD shift switch: 4H	On	
		4WD shift switch: 2WD and 4LO	Off	
4L SWITCH [On/Off]	Input condition from 4WD shift switch	4WD shift switch: 4LO	On	
		4WD shift switch: 2WD and 4H	Off	
4L POSI SW [On/Off]	Condition of 4LO switch	<ul style="list-style-type: none"> • Vehicle stopped • Engine running • A/T selector lever "N" position • Brake pedal depressed 	4WD shift switch: 4LO On	
		Except the above	Off	
ATP SWITCH [On/Off]	Condition of ATP switch	<ul style="list-style-type: none"> • Vehicle stopped • Engine running • A/T selector lever "N" position • Brake pedal depressed 	4WD shift switch : 4H to 4LO or 4LO to 4H (While actuator motor is operating.) On	
		Except the above	Off	
WAIT DETCT SW [On/Off]	Condition of wait detection switch	<ul style="list-style-type: none"> • Vehicle stopped • Engine running • A/T selector lever "N" position • Brake pedal depressed 	4WD shift switch : 4H and 4LO On	
		4WD shift switch: 2WD	Off	
4WD MODE [2H/4H/4L]	Control status of 4WD (Output condition of 4WD shift indicator lamp and 4LO indicator lamp)	4WD shift switch (Engine running)	2WD	2H
			4H	4H
			4LO	4L

TRANSFER CONTROL UNIT

< ECU DIAGNOSIS INFORMATION >

[TRANSFER: TX15B]

Monitored item [Unit]	Content	Condition	Display value
VHCL/S COMP [km/h] or [mph]	Vehicle speed	Vehicle stopped	0 km/h (0 mph)
		Vehicle running CAUTION: Check air pressure of tire under standard condition.	Approximately equal to the indication on speedometer (Inside of ±10%)
SHIFT ACT 1 [On/Off]	Output condition to actuator motor (clockwise)	<ul style="list-style-type: none"> • Vehicle stopped • Engine running • A/T selector lever "N" position • Brake pedal depressed 	4WD shift switch : 2WD to 4H or 4H to 4LO or 2WD to 4LO On
		Except the above	Off
SHIFT AC MON1 [On/Off]	Check signal for transfer control unit signal output	<ul style="list-style-type: none"> • Vehicle stopped • Engine running • A/T selector lever "N" position • Brake pedal depressed 	4WD shift switch : 2WD to 4H or 4H to 4LO or 2WD to 4LO On
		Except the above	Off
SHIFT ACT 2 [On/Off]	Output condition to actuator motor (counterclockwise)	<ul style="list-style-type: none"> • Vehicle stopped • Engine running • A/T selector lever "N" position • Brake pedal depressed 	4WD shift switch : 4LO to 4H or 4H to 2WD or 4LO to 2WD On
		Except the above	Off
SHIFT AC MON2 [On/Off]	Check signal for transfer control unit signal output	<ul style="list-style-type: none"> • Vehicle stopped • Engine running • A/T selector lever "N" position • Brake pedal depressed 	4WD shift switch : 4LO to 4H or 4H to 2WD or 4LO to 2WD On
		Except the above	Off
SHIFT ACT/R MON [On/Off]	Operating condition of actuator motor relay (integrated in transfer control unit)	<ul style="list-style-type: none"> • Vehicle stopped • Engine running • A/T selector lever "N" position • Brake pedal depressed 	When 4WD shift switch is operated On
		When 4WD shift switch is not operated Off	
SHIFT POS SW1 [On/Off]	Condition of actuator position switch 1	<ul style="list-style-type: none"> • Vehicle stopped • Engine running • A/T selector lever "N" position • Brake pedal depressed 	4WD shift switch: 2WD and 4LO On
SHIFT POS SW2 [On/Off]	Condition of actuator position switch 2		4WD shift switch: 4H Off
			4WD shift switch: 4LO On
SHIFT POS SW3 [On/Off]	Condition of actuator position switch 3		4WD shift switch: 2WD and 4H On
			4WD shift switch: 4LO Off
SHIFT POS SW4 [On/Off]	Condition of actuator position switch 4		4WD shift switch: 4H and 4LO On
			4WD shift switch: 2WD Off
4WD FAIL LAMP [On/Off]	4WD warning lamp condition		4WD warning lamp: On On
		4WD warning lamp: Off Off	
2WD IND [On/Off]	Rear indicator of 4WD shift indicator lamp condition	Rear indicator of 4WD shift indicator lamp: On On	
		Rear indicator of 4WD shift indicator lamp: Off Off	
4H IND [On/Off]	Front and center indicator of 4WD shift indicator lamp condition	Front and center indicator of 4WD shift indicator lamp : ON On	
		Front and center indicator of 4WD shift indicator lamp : OFF Off	
4L IND [On/Off]	4LO indicator lamp condition	4LO indicator lamp: On On	
		4LO indicator lamp: Off Off	

A
B
C
DLN
E
F
G
H
I
J
K
L
M
N
O
P

PHYSICAL VALUES

TRANSFER CONTROL UNIT

< ECU DIAGNOSIS INFORMATION >

[TRANSFER: TX15B]

Terminal Layout

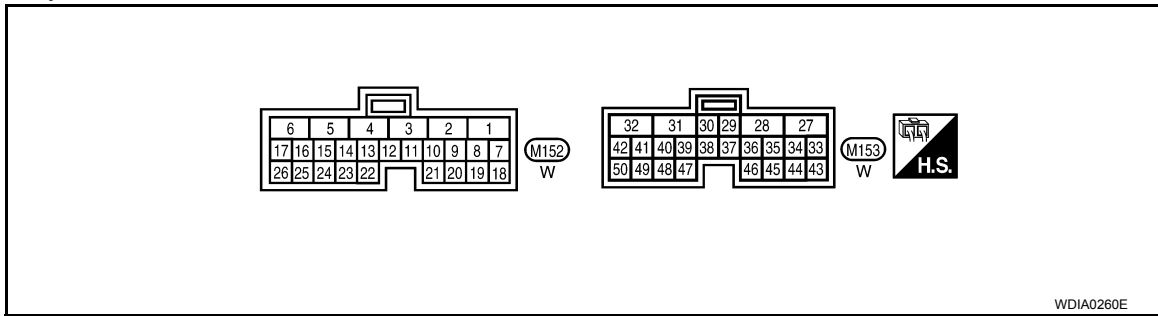

Terminal	Wire color	Item	Condition	Data (Approx.)
1	L	CAN-H	–	–
2	P	CAN-L	–	–
3	SB	K-LINE (CONSULT signal)	–	–
6	B	Ground (M/T models)	Always	0V
10	LG	Actuator position switch 1	4WD shift switch: 2WD and 4LO	0V
11	W	Actuator position switch 2	4WD shift switch: 4H	Battery voltage
			4WD shift switch: 4LO	0V
12	BR	Actuator position switch 3	4WD shift switch: 2WD and 4H	Battery voltage
			4WD shift switch: 2WD and 4H	0V
13	L	Actuator position switch 4	4WD shift switch: 4LO	Battery voltage
			4WD shift switch: 4H and 4LO	0V
14	G	4WD shift switch (2WD)	4WD shift switch: 2WD	Battery voltage
			4WD shift switch: 2WD	Battery voltage
15	O	4WD shift switch (4H)	4WD shift switch: 4H and 4LO	0V
			4WD shift switch: 4H	Battery voltage
16	W	4WD shift switch (4LO)	4WD shift switch: 2WD and 4LO	0V
			4WD shift switch: 4LO	Battery voltage
17	O	Wait detection switch	4WD shift switch: 4H and 4LO	0V
			4WD shift switch: 2WD	Battery voltage
18	B	Ground	Always	0V
19	R	Power supply (Memory back-up)	Ignition switch: ON	Battery voltage
			Ignition switch: OFF	Battery voltage
23	R	ATP switch (A/T models)	4WD shift switch : 4H to 4LO or 4LO to 4H (While actuator motor is operating.)	0V
			Except the above	Battery voltage
24	Y	4LO switch	4WD shift switch: 4LO	0V
			Except the above	Battery voltage

TRANSFER CONTROL UNIT

< ECU DIAGNOSIS INFORMATION >

[TRANSFER: TX15B]

Terminal	Wire color	Item	Condition		Data (Approx.)	
25	W/G	Ignition switch monitor	Ignition switch: ON		Battery voltage	
			Ignition switch: OFF		0V	
27	L	Actuator motor power supply	Ignition switch: ON		Battery voltage	
			Ignition switch: OFF (5 seconds after ignition switch is turned OFF)		0V	
28	SB	Actuator motor (+)	<ul style="list-style-type: none"> • Vehicle stopped • Engine running • A/T selector lever "N" position • Brake pedal depressed 	When 4WD shift switch is operated (while actuator motor is operating)	Battery voltage → 0V	
31	G	Actuator motor (-)		When 4WD shift switch is not operated	0V	
				Always	0V	
32	B	Ground	Always		0V	
33	P	Park/Neutral position switch (M/T models)	Ignition switch: ON	M/T shift lever neutral position	0V	
				Except the above		Battery voltage
35	V	4WD shift indicator lamp (Rear indicator)	Engine running	Rear indicator of 4WD shift indicator lamp : ON	0V	
				Rear indicator of 4WD shift indicator lamp : OFF	Battery voltage	
36	BR	4WD shift indicator lamp (Front and center indicator)		Front and center indicator of 4WD shift indicator lamp: ON	0V	
				Front and center indicator of 4WD shift indicator lamp: OFF	Battery voltage	
37	O	4LO indicator lamp		4LO indicator lamp: ON	0V	
				4LO indicator lamp: OFF	Battery voltage	
38	GR	4WD warning lamp		4WD warning lamp: ON	0V	
				4WD warning lamp: OFF	Battery voltage	
39	LG	ATP warning lamp (A/T models)		<ul style="list-style-type: none"> • Vehicle stopped • Engine running • A/T selector lever "P" position • Brake pedal depressed 	4WD shift switch: 4H to 4LO or 4LO to 4H (While actuator motor is operating.)	Battery voltage
					Except the above	
40	V	Transfer shut off relay	Ignition switch: ON		0V	
			Ignition switch: OFF (5 seconds after ignition switch is turned OFF)		Battery voltage	
42	LG	Transfer shift high relay	<ul style="list-style-type: none"> • Vehicle stopped • Engine running • A/T selector lever "N" position • Brake pedal depressed 	4WD shift switch: 2WD to 4H or 4H to 4LO or 2WD to 4LO	0V	
				Except the above		Battery voltage
44	Y	Power supply	Ignition switch: ON		Battery voltage	
			Ignition switch: OFF (5 seconds after ignition switch is turned OFF)		0V	
45	GR	Power supply	Ignition switch: ON		Battery voltage	
			Ignition switch: OFF (5 seconds after ignition switch is turned OFF)		0V	

A
B
C
DLN
E
F
G
H
I
J
K
L
M
N
O
P

TRANSFER CONTROL UNIT

< ECU DIAGNOSIS INFORMATION >

[TRANSFER: TX15B]

Terminal	Wire color	Item	Condition	Data (Approx.)
47	O	Transfer shift high relay monitor	4WD shift switch: 2WD to 4H or 4H to 4LO or 2WD to 4LO (while actuator motor is operating)	Battery voltage → 0V
			Except the above	0V
48	R	Transfer shift low relay monitor	4WD shift switch: 4LO to 4H or 4H to 2WD or 4LO to 2WD (while actuator motor is operating)	Battery voltage → 0V
			Except the above	0V
50	Y	Transfer shift low relay	4WD shift switch: 4LO to 4H or 4H to 2WD or 4LO to 2WD	0V
			Except the above	Battery voltage

CAUTION:

When using a circuit tester to measure voltage for inspection, be sure not to extend forcibly any connector terminals.

NOTE:

Data are reference value and are measured between each terminal and ground.

DTC Index

INFOID:000000007323906

DTC CHART

DTC	CONSULT	Diagnostic item is detected when...	Reference
[P1801]	*INITIAL START*	Due to removal of battery which cuts off power supply to transfer control unit, self-diagnosis memory function is suspended.	DLN-21
[P1802]	CONTROL UNIT (1,2,3)	Malfunction is detected in the memory (RAM) system of transfer control unit.	DLN-24
[P1803]		Malfunction is detected in the memory (ROM) system of transfer control unit.	
[P1804]		Malfunction is detected in the memory (EEPROM) system of transfer control unit.	
[P1807]	VHCL SPEED SEN·AT	<ul style="list-style-type: none"> Malfunction is detected in output shaft revolution signal that is output from TCM through CAN communication. Improper signal is input while driving. 	DLN-26
[P1808]	VHCL SPEED SEN·ABS	<ul style="list-style-type: none"> Malfunction is detected in vehicle speed signal that is output from ABS actuator and electric unit (control unit) through CAN communication. Improper signal is input while driving. 	DLN-27
[P1809]	CONTROL UNIT 4	AD converter system of transfer control unit is malfunctioning.	DLN-24
[P1810]	4L POSI SW TF	Improper signal from 4LO switch is input due to open or short circuit.	DLN-28
[P1811]	BATTERY VOLTAGE	Power supply voltage for transfer control unit is abnormally low while driving.	DLN-21
[P1813]	4WD MODE SW	More than two switch inputs are simultaneously detected due to short circuit of 4WD shift switch.	DLN-31
[P1814]	4WD DETECT SWITCH	Improper signal from wait detection switch is input due to open or short circuit.	DLN-34
[P1816]	PNP SW/CIRC	When transmission range switch (A/T models) signal is malfunctioning.	DLN-37
		When PNP switch (M/T models) signal is malfunctioning.	DLN-38

TRANSFER CONTROL UNIT

< ECU DIAGNOSIS INFORMATION >

[TRANSFER: TX15B]

DTC	CONSULT	Diagnostic item is detected when...	Reference
[P1817]	SHIFT ACTUATOR	<ul style="list-style-type: none"> Motor does not operate properly due to open or short circuit in actuator motor. Malfunction is detected in the actuator motor. (When 4WD shift switch is operated and actuator motor is not operated) Malfunction is detected in transfer shift high relay or transfer shift low relay. 	DLN-41
[P1818]	SHIFT ACT POSI SW	<ul style="list-style-type: none"> Improper signal from actuator position switch is input due to open or short circuit. Malfunction is detected in actuator position switch. 	DLN-48
[P1819]	SHIFT ACT CIR	<ul style="list-style-type: none"> Malfunction is detected in transfer shut off relay 1 and transfer shut off relay 2. Malfunction occurs in transfer control device drive circuit. 	DLN-51
[P1820]	ENGINE SPEED SIG	<ul style="list-style-type: none"> Malfunction is detected in engine speed signal that is output from ECM through CAN communication. Improper signal is input while driving. 	DLN-54
[U1010]	CONTROL UNIT (CAN)	Detecting error during the initial diagnosis of CAN controller of transfer control unit.	DLN-55

NOTE:

If "SHIFT ACT POSI SW [P1818]" or "SHIFT ACT CIR [P1819]" is displayed, first erase self-diagnostic results. ("SHIFT ACT POSI SW [P1818]" or "SHIFT ACT CIR [P1819]" may be displayed after installing transfer control unit or transfer assembly.)

FLASH CODE CHART

Flashing pattern	Item	Diagnostic item is detected when...	Reference
2	Output shaft revolution signal (from TCM)	<ul style="list-style-type: none"> Malfunction is detected in output shaft revolution signal that is output from TCM through CAN communication. Improper signal is input while driving. 	DLN-26
3	Vehicle speed signal (from ABS)	<ul style="list-style-type: none"> Malfunction is detected in vehicle speed signal that is output from ABS actuator and electric unit (control unit) through CAN communication. Improper signal is input while driving. 	DLN-27
4	CAN communication	Malfunction has been detected from CAN communication.	DLN-14
5	AD converter	AD converter system of transfer control unit is malfunctioning.	DLN-24
6	4LO switch	Improper signal from 4LO switch is input due to open or short circuit.	DLN-28
7	Engine speed signal	<ul style="list-style-type: none"> Malfunction is detected in engine speed signal that is output from ECM through CAN communication. Improper signal is input while driving. 	DLN-54
8	Power supply	Power supply voltage for transfer control unit is abnormally low while driving.	DLN-21
9	4WD shift switch	More than two switch inputs are simultaneously detected due to short circuit of 4WD shift switch.	DLN-31
10	Wait detection switch	Improper signal from wait detection switch is input due to open or short circuit.	DLN-34

TRANSFER CONTROL UNIT

< ECU DIAGNOSIS INFORMATION >

[TRANSFER: TX15B]

Flashing pattern	Item	Diagnostic item is detected when...	Reference
11	Actuator motor	<ul style="list-style-type: none"> Motor does not operate properly due to open or short circuit in actuator motor. Malfunction is detected in the actuator motor. (When 4WD shift switch is operated and actuator motor is not operated.) Malfunction is detected in transfer shift high relay or transfer shift low relay. 	DLN-41
12	Actuator position switch	<ul style="list-style-type: none"> Improper signal from actuator position switch is input due to open or short circuit. Malfunction is detected in the actuator position switch. 	DLN-48
13	Transfer control device	<ul style="list-style-type: none"> Malfunction is detected in transfer shut off relay 1 and transfer shut off 2. Malfunction occurs in transfer control device drive circuit. 	DLN-51
14	Transmission range switch signal (A/T models)	When transmission range switch signal is malfunctioning.	DLN-37
	PNP switch signal (M/T models)	When PNP switch signal is malfunctioning.	DLN-38
Repeats flickering every 0.25 sec.	Data erase display	<ul style="list-style-type: none"> Power supply failure of memory back-up. Battery is disconnected for a long time. Battery performance is poor. 	DLN-21
Repeats flickering every 2 to 5 sec.	—	Circuits that the self-diagnosis covers have no malfunction.	—
No flickering	PNP switch (M/T models), transmission range switch (A/T models) or 4WD shift switch	PNP switch (M/T models), transmission range switch (A/T models) or 4WD shift switch circuit is shorted or open.	DLN-38 (M/T models), DLN-37 (A/T models) or DLN-31

NOTE:

If actuator position switch" or transfer control device" is displayed, first erase self-diagnostic results. (They may be displayed after installing transfer control unit or transfer assembly.)

PART TIME 4WD SYSTEM

< WIRING DIAGRAM >

[TRANSFER: TX15B]

WIRING DIAGRAM

PART TIME 4WD SYSTEM

Wiring Diagram

INFOID:000000007323907

PART TIME 4WD SYSTEM

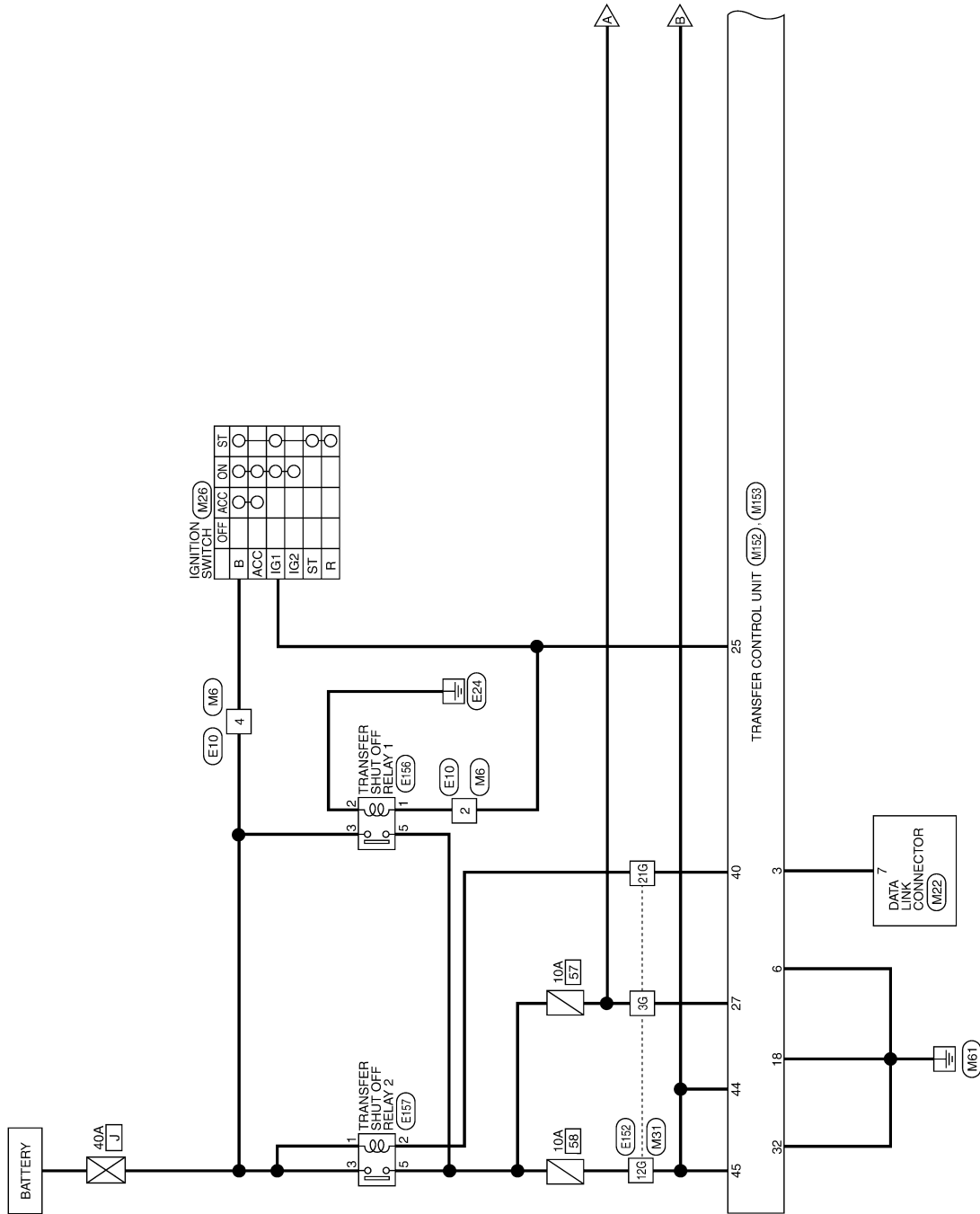

ABDWA0054GB

A
B
C
DLN
E
F
G
H
I
J
K
L
M
N
O
P

PART TIME 4WD SYSTEM

< WIRING DIAGRAM >

[TRANSFER: TX15B]

(M) WITH M/T

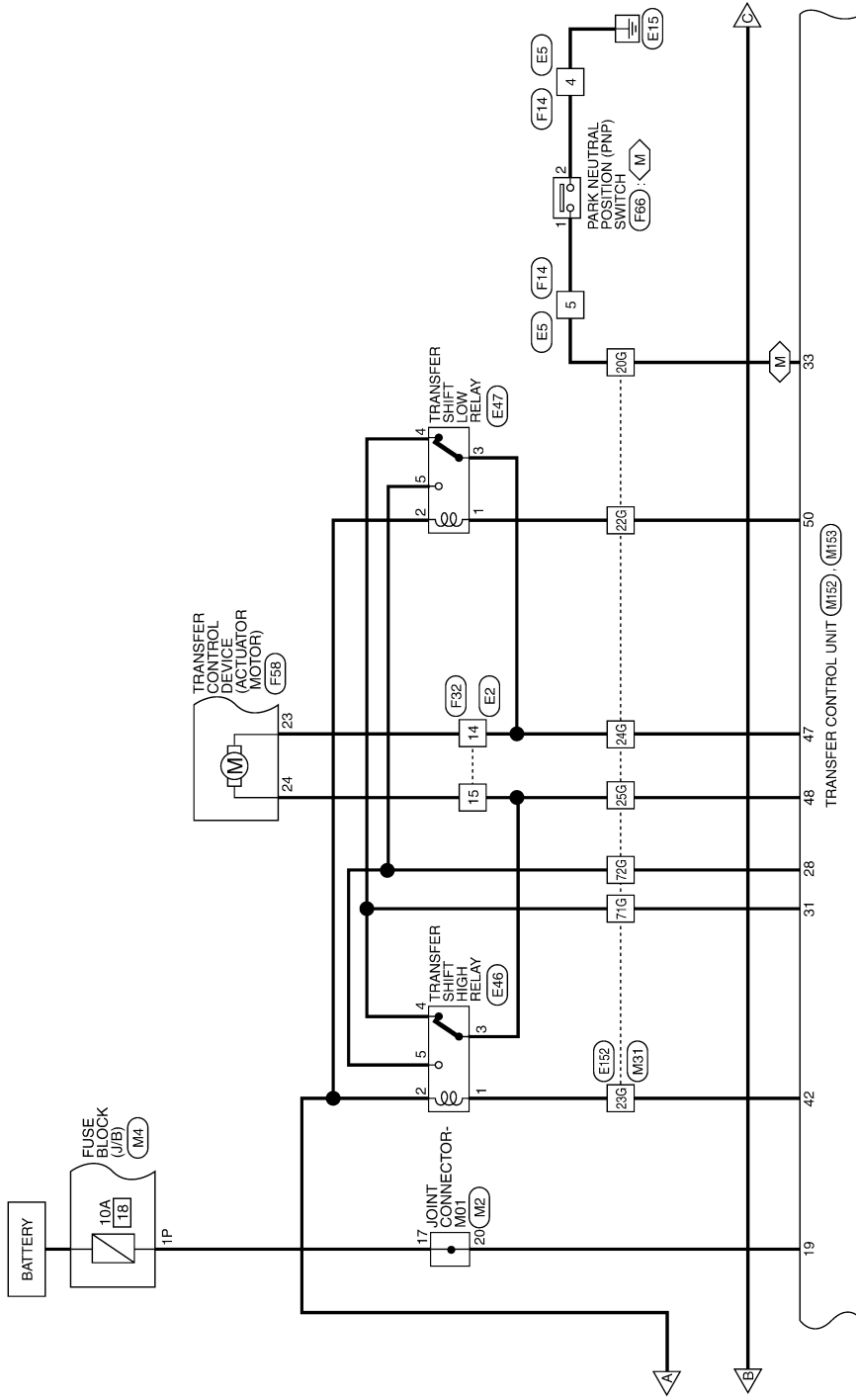

AADWA0201GB

PART TIME 4WD SYSTEM

< WIRING DIAGRAM >

[TRANSFER: TX15B]

⬡: WITH A/T

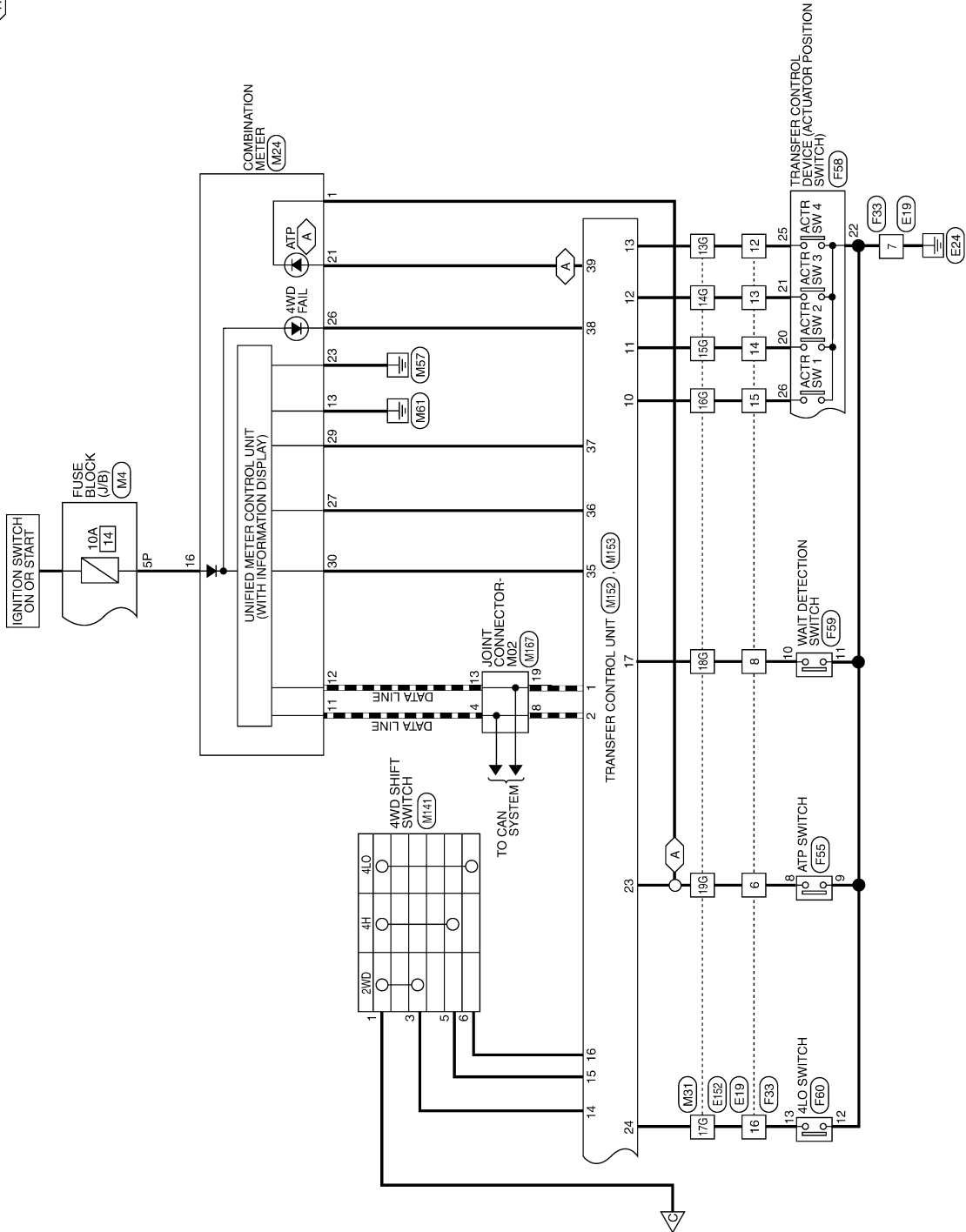

ABDWA0575GB

A
B
C
DLN
E
F
G
H
I
J
K
L
M
N
O
P

PART TIME 4WD SYSTEM

< WIRING DIAGRAM >

[TRANSFER: TX15B]

PART TIME 4WD SYSTEM CONNECTORS

Connector No.	M2
Connector Name	JOINT CONNECTOR-M01
Connector Color	BLUE

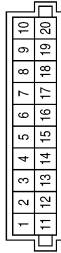

Terminal No.	Color of Wire	Signal Name
17	R/B	-
20	R	-

Connector No.	M4
Connector Name	FUSE BLOCK (J/B)
Connector Color	WHITE



Terminal No.	Color of Wire	Signal Name
1P	R/B	-
5P	W/G	-

Connector No.	M6
Connector Name	WIPE TO WIRE
Connector Color	WHITE



Terminal No.	Color of Wire	Signal Name
2	W/G	-
4	G	-

Connector No.	M22
Connector Name	DATA LINK CONNECTOR
Connector Color	WHITE

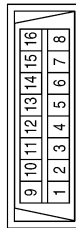

Terminal No.	Color of Wire	Signal Name
7	W	-

Connector No.	M24
Connector Name	COMBINATION METER
Connector Color	WHITE

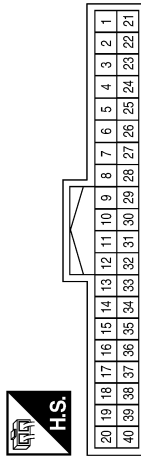

Terminal No.	Color of Wire	Signal Name
1	R	ATP-
11	P	CAN-L
12	L	CAN-H
13	GR	GROUND
16	W/G	RUN START
21	LG	ATP+
23	B	POWER GND
26	GR	4WD FAIL
27	BR	4WD (LOCK) INPUT
29	O	4WD (4LO) INPUT
30	V	4WD (2WD) INPUT

Connector No.	M26
Connector Name	IGNITION SWITCH
Connector Color	WHITE



Terminal No.	Color of Wire	Signal Name
B	G	-
IG1	W/G	-

PART TIME 4WD SYSTEM

< WIRING DIAGRAM >

[TRANSFER: TX15B]

Terminal No.	Color of Wire	Signal Name
24G	O	-
25G	R	-
71G	G	-
72G	SB	-

Terminal No.	Color of Wire	Signal Name
3G	L	-
12G	GR	-
13G	L	-
14G	BR	-
15G	W	-
16G	LG	-
17G	Y	-
18G	O	-
19G	R	-
20G	P	-
21G	V	-
22G	Y	-
23G	LG	-

Connector No.	M31
Connector Name	WIRE TO WIRE
Connector Color	WHITE

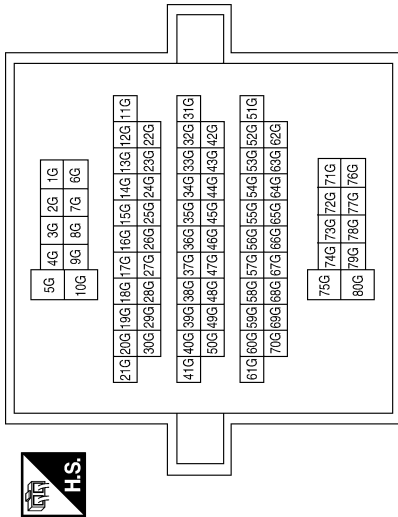

Terminal No.	Color of Wire	Signal Name
10	LG	ACTR SW1
11	W	ACTR SW2
12	BR	ACTR SW3
13	L	ACTR SW4
14	G	2WD SW
15	O	4H SW
16	W	4L SW
17	O	4WD POSITION SW
18	B	GND
19	R	MEMOR B/U
20	-	-
21	-	-
22	-	-
23	R	ATP-SW
24	Y	4L POSITION SW
25	W/G	IGN SW
26	-	-

Connector No.	M152
Connector Name	TRANSFER CONTROL UNIT
Connector Color	WHITE

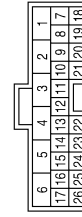

Terminal No.	Color of Wire	Signal Name
1	L	CAN-H
2	P	CAN-L
3	SB	K-LINE
4	-	-
5	-	-
6	B	GND
7	-	-
8	-	-
9	-	-

Connector No.	M141
Connector Name	4WD SHIFT SWITCH
Connector Color	GRAY



Terminal No.	Color of Wire	Signal Name
1	Y	+
3	G	2WD
5	O	LOCK
6	W	4LO

ABDIA0865GB

A
B
C
DLN
E
F
G
H
I
J
K
L
M
N
O
P

PART TIME 4WD SYSTEM

< WIRING DIAGRAM >

[TRANSFER: TX15B]

Connector No.	M167
Connector Name	JOINT CONNECTOR-M02
Connector Color	BLUE

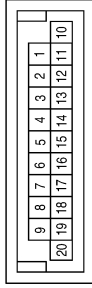

Terminal No.	Color of Wire	Signal Name
4	P	-
8	P	-
13	L	-
19	L	-

Terminal No.	Color of Wire	Signal Name
35	V	2WD IND
36	BR	4H IND
37	O	4LO IND
38	GR	4WD FAIL
39	LG	ATP IND (WITH A/T)
40	V	SSOF
41	-	-
42	LG	MTR RLY 1
43	-	-
44	Y	V IGN
45	GR	V IGN
46	-	-
47	O	MTR MONITOR 1
48	R	MTR MONITOR 2
49	-	-
50	Y	MTR RELAY 2

Connector No.	M153
Connector Name	TRANSFER CONTROL UNIT
Connector Color	WHITE

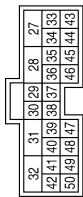

Terminal No.	Color of Wire	Signal Name
27	L	V IGN
28	SB	MOTOR +
29	-	-
30	-	-
31	G	MOTOR -
32	B	GND
33	P	NEUT SW (WITH M/T)
34	-	-

Connector No.	E10
Connector Name	WIRE TO WIRE
Connector Color	WHITE



Terminal No.	Color of Wire	Signal Name
2	W/G	-
4	G	-

Connector No.	E5
Connector Name	WIRE TO WIRE
Connector Color	WHITE

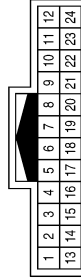

Terminal No.	Color of Wire	Signal Name
4	B/Y	-
5	O	-

Connector No.	E2
Connector Name	WIRE TO WIRE
Connector Color	WHITE

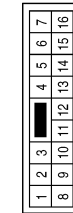

Terminal No.	Color of Wire	Signal Name
14	O	-
15	GR	-

ABDIA0866GB

PART TIME 4WD SYSTEM

< WIRING DIAGRAM >

[TRANSFER: TX15B]

Connector No.	E47
Connector Name	TRANSFER SHIFT LOW RELAY
Connector Color	BLACK

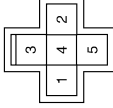

Terminal No.	Color of Wire	Signal Name
1	Y	-
2	R	-
3	O	-
4	G	-
5	SB	-

Connector No.	E46
Connector Name	TRANSFER SHIFT HIGH RELAY
Connector Color	BLACK

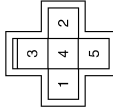

Terminal No.	Color of Wire	Signal Name
1	LG	-
2	R	-
3	GR	-
4	G	-
5	SB	-

Connector No.	E19
Connector Name	WIRE TO WIRE
Connector Color	WHITE

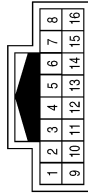

Terminal No.	Color of Wire	Signal Name
6	R	-
7	B	-
8	O	-
12	L	-
13	BR	-
14	W	-
15	LG	-
16	Y	-

Terminal No.	Color of Wire	Signal Name
24G	O	-
25G	R	-
71G	G	-
72G	SB	-

Terminal No.	Color of Wire	Signal Name
3G	L	-
12G	GR	-
13G	L	-
14G	BR	-
15G	W	-
16G	LG	-
17G	Y	-
18G	O	-
19G	R	-
20G	P	-
21G	V	-
22G	Y	-
23G	LG	-

Connector No.	E152
Connector Name	WIRE TO WIRE
Connector Color	WHITE

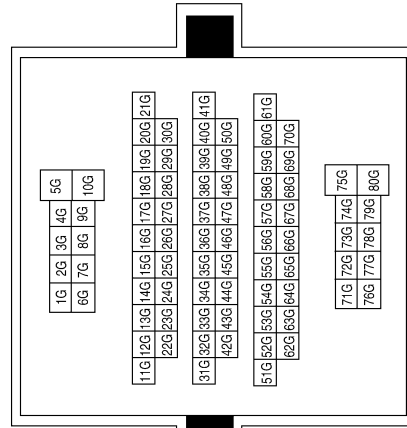

ABDIA0867GB

A
B
C
DLN
E
F
G
H
I
J
K
L
M
N
O
P

PART TIME 4WD SYSTEM

< WIRING DIAGRAM >

[TRANSFER: TX15B]

Connector No.	E156
Connector Name	TRANSFER SHUT OFF RELAY 1
Connector Color	BLUE



Terminal No.	Color of Wire	Signal Name
1	W/G	-
2	B	-
3	B	-
5	W	-

Connector No.	E157
Connector Name	TRANSFER SHUT OFF RELAY 2
Connector Color	BLUE



Terminal No.	Color of Wire	Signal Name
1	G	-
2	V	-
3	B	-
5	W	-

Connector No.	F14
Connector Name	WIRE TO WIRE
Connector Color	WHITE

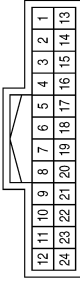

Terminal No.	Color of Wire	Signal Name
4	B/Y	-
5	O	-

Connector No.	F32
Connector Name	WIRE TO WIRE
Connector Color	WHITE

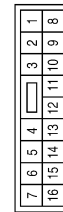

Terminal No.	Color of Wire	Signal Name
14	O	-
15	GR	-

Connector No.	F33
Connector Name	WIRE TO WIRE
Connector Color	WHITE

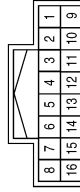

Terminal No.	Color of Wire	Signal Name
6	R	-
7	B	-
8	O	-
12	L	-
13	BR	-
14	W	-
15	LG	-
16	Y	-

Connector No.	F55
Connector Name	ATP SWITCH
Connector Color	BLACK



Terminal No.	Color of Wire	Signal Name
8	R	-
9	B	-

ABDIA0142GB

PART TIME 4WD SYSTEM

< WIRING DIAGRAM >

[TRANSFER: TX15B]

Connector No.	F60
Connector Name	4LO SWITCH
Connector Color	GRAY

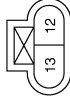

Terminal No.	Color of Wire	Signal Name
12	B	-
13	Y	-

Connector No.	F59
Connector Name	WAIT DETECTION SWITCH
Connector Color	GRAY



Terminal No.	Color of Wire	Signal Name
10	O	-
11	B	-

Connector No.	F58
Connector Name	TRANSFER CONTROL DEVICE
Connector Color	BLACK

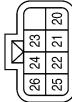

Terminal No.	Color of Wire	Signal Name
20	W	ACTR SW 2
21	BR	ACTR SW 3
22	B	-
23	O	-
24	GR	-
25	L	ACTR SW 4
26	LG	ACTR SW 1

Connector No.	F66
Connector Name	PARK NEUTRAL POSITION (PNP) SWITCH
Connector Color	BLACK



Terminal No.	Color of Wire	Signal Name
1	O	-
2	B/Y	-

ABDIA0143GB

A
B
C
DLN
E
F
G
H
I
J
K
L
M
N
O
P

4WD SYSTEM SYMPTOMS

< SYMPTOM DIAGNOSIS >

[TRANSFER: TX15B]

SYMPTOM DIAGNOSIS

4WD SYSTEM SYMPTOMS

Symptom Table

INFOID:000000007323908

Symptom	Condition	Reference page
4WD shift indicator lamp and 4LO indicator lamp do not turn ON (lamp check)	Ignition switch: ON	DLN-75
4WD warning lamp does not turn ON (lamp check)		DLN-73
4WD shift indicator lamp or 4LO indicator lamp does not change	Engine running	DLN-77
ATP warning lamp does not turn ON		DLN-79
ATP switch is malfunctioning		DLN-83
4WD shift indicator lamp repeats flashing	While driving	DLN-81
4WD warning lamp flashes slowly (1 time/2 seconds)		DLN-82

4WD WARNING LAMP DOES NOT TURN ON

< SYMPTOM DIAGNOSIS >

[TRANSFER: TX15B]

4WD WARNING LAMP DOES NOT TURN ON

Description

INFOID:000000007323909

4WD warning lamp does not turn ON when turning ignition switch to ON.

Diagnosis Procedure

INFOID:000000007323910

Regarding Wiring Diagram information, refer to [DLN-63, "Wiring Diagram"](#).

1. CHECK TRANSFER CONTROL UNIT POWER SUPPLY AND GROUND CIRCUITS

Refer to [DLN-21, "Diagnosis Procedure"](#).

Are the inspection results normal?

YES >> GO TO 2.

NO >> Perform repairs as necessary.

2. CHECK COMBINATION METER POWER SUPPLY CIRCUIT

1. Turn ignition switch "OFF". (Stay for at least 5 seconds.)
2. Disconnect combination meter harness connector.
3. Check voltage between combination meter harness connector terminals and ground.

Connector	Terminal	Voltage (Approx.)
M24	16 - Ground	0V

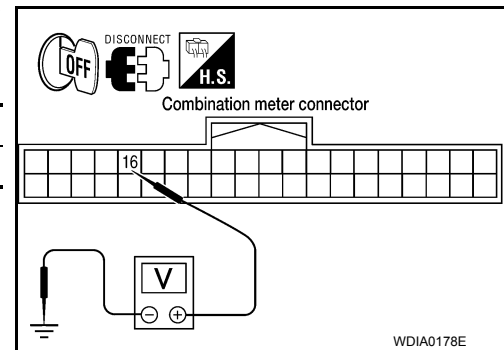

4. Turn ignition switch "ON". (Do not start engine.)
5. Check voltage between combination meter harness connector terminals and ground.

Connector	Terminal	Voltage (Approx.)
M24	16 - Ground	Battery voltage

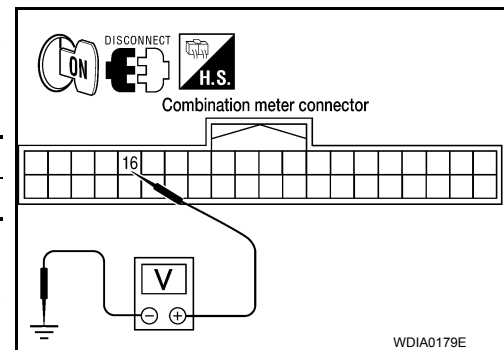

Are the inspection results normal?

YES >> GO TO 3.

NO >> Check the following. If any items are damaged, repair or replace damaged parts.

- 10A fuse [No. 14, located in the fuse block (J/B)] or ignition switch.
- Harness for short or open between ignition switch and combination meter harness connector terminal 16

3. CHECK HARNESS BETWEEN TRANSFER CONTROL UNIT AND COMBINATION METER

1. Turn ignition switch "OFF". (Stay for at least 5 seconds.)

4WD WARNING LAMP DOES NOT TURN ON

< SYMPTOM DIAGNOSIS >

[TRANSFER: TX15B]

2. Check continuity between transfer control unit harness connector M153 terminal 38 and combination meter harness connector M24 terminal 26.

Continuity should exist.

Also check harness for short to ground and short to power.

Is there continuity?

- YES >> GO TO 4.
- NO >> Repair or replace damaged parts.

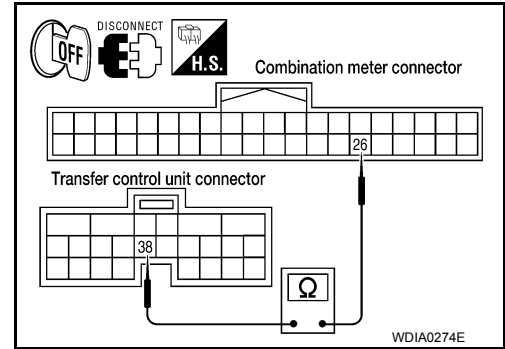

4.CHECK INDICATOR LAMP CIRCUIT

1. Turn ignition switch "OFF". (Stay for at least 5 seconds.)
2. Connect combination meter harness connector.
3. Disconnect transfer control unit harness connector.
4. Turn ignition switch "ON". (Do not start engine.)
5. Ground the following terminal using suitable wiring.
 - Transfer control unit harness connector M153 terminal 38 and ground.

Does the indicator lamp turn on?

- YES >> GO TO 5.
- NO >> Replace the combination meter. Refer to [MWI-89](#), "[Removal and Installation](#)".

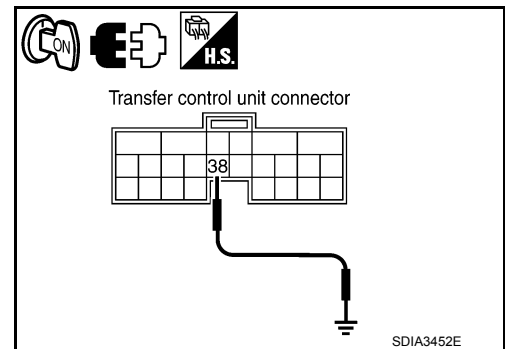

5.SYMPTOM CHECK

Check again.

Does the symptom still occur?

- YES >> GO TO 6.
- NO >> Inspection End.

6.CHECK TRANSFER CONTROL UNIT

Check transfer control unit input/output signal. Refer to [DLN-56](#), "[Reference Value](#)".

Are the inspection results normal?

- YES >> Inspection End.
- NO >> Check transfer control unit pin terminals for damage or loose connection with harness connector. If any items are damaged, repair or replace damaged parts.

4WD SHIFT INDICATOR LAMP AND 4LO INDICATOR LAMP DO NOT TURN ON

< SYMPTOM DIAGNOSIS > [TRANSFER: TX15B]

4WD SHIFT INDICATOR LAMP AND 4LO INDICATOR LAMP DO NOT TURN ON

Description

INFOID:000000007323911

4WD shift indicator lamp and 4LO indicator lamp do not turn ON for approx. 1 second when turning ignition switch to ON.

Diagnosis Procedure

INFOID:000000007323912

Regarding Wiring Diagram information, refer to [DLN-63, "Wiring Diagram"](#).

1. CHECK TRANSFER CONTROL UNIT POWER SUPPLY AND GROUND CIRCUITS

Refer to [DLN-21, "Diagnosis Procedure"](#).

Are the inspection results normal?

- YES >> GO TO 2.
 NO >> Perform repairs as necessary.

2. CHECK COMBINATION METER POWER SUPPLY CIRCUIT

1. Turn ignition switch "OFF". (Stay for at least 5 seconds.)
2. Disconnect combination meter harness connector.
3. Check voltage between combination meter harness connector terminals and ground.

Connector	Terminal	Voltage (Approx.)
M24	16 - Ground	0V

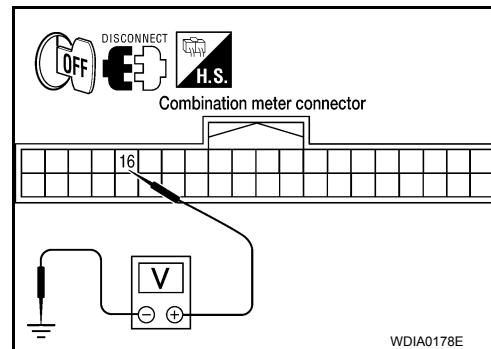

4. Turn ignition switch "ON". (Do not start engine.)
5. Check voltage between combination meter harness connector terminals and ground.

Connector	Terminal	Voltage (Approx.)
M24	16 - Ground	Battery voltage

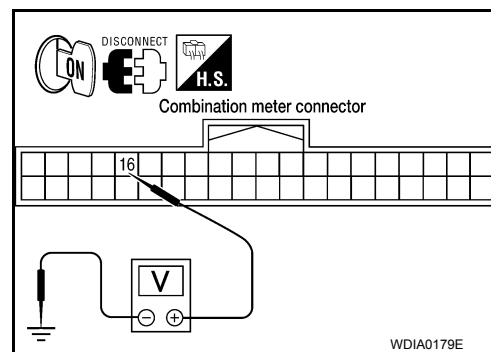

Are the inspection results normal?

- YES >> GO TO 3.
 NO >> Check the following. If any items are damaged, repair or replace damaged parts.
- 10A fuse [No. 14, located in the fuse block (J/B)] or ignition switch.
 - Harness for short or open between ignition switch and combination meter harness connector terminal 16

3. CHECK HARNESS BETWEEN TRANSFER CONTROL UNIT AND COMBINATION METER

1. Turn ignition switch "OFF". (Stay for at least 5 seconds.)

4WD SHIFT INDICATOR LAMP AND 4LO INDICATOR LAMP DO NOT TURN ON

[TRANSFER: TX15B]

< SYMPTOM DIAGNOSIS >

2. Check continuity between the following terminals.
 - Transfer control unit harness connector M153 terminal 35 and combination meter harness connector M24 terminal 30.
 - Transfer control unit harness connector M153 terminal 36 and combination meter harness connector M24 terminal 27.
 - Transfer control unit harness connector M153 terminal 37 and combination meter harness connector M24 terminal 29.

Continuity should exist.

Also check harness for short to ground and short to power.

Does continuity exist?

- YES >> GO TO 4.
NO >> Repair or replace damaged parts.

4. CHECK INDICATOR LAMP CIRCUIT

1. Turn ignition switch "OFF". (Stay for at least 5 seconds.)
2. Connect combination meter harness connector.
3. Disconnect transfer control unit harness connector.
4. Turn ignition switch "ON". (Do not start engine.)
5. Ground the following terminals using suitable wiring.
 - Transfer control unit harness connector M153 terminal 35 and ground.
 - Transfer control unit harness connector M153 terminal 36 and ground.
 - Transfer control unit harness connector M153 terminal 37 and ground.

Do indicator lamps turn on?

- YES >> GO TO 5.
NO >> Replace the combination meter. Refer to [MWI-89](#).
["Removal and Installation"](#).

5. SYMPTOM CHECK

Check again.

Does the symptom still occur?

- YES >> GO TO 6.
NO >> Inspection End.

6. CHECK TRANSFER CONTROL UNIT

Check transfer control unit input/output signal. Refer to [DLN-56](#). ["Reference Value"](#).

Are the inspection results normal?

- YES >> Inspection End.
NO >> Check transfer control unit pin terminals for damage or loose connection with harness connector. If any items are damaged, repair or replace damaged parts.

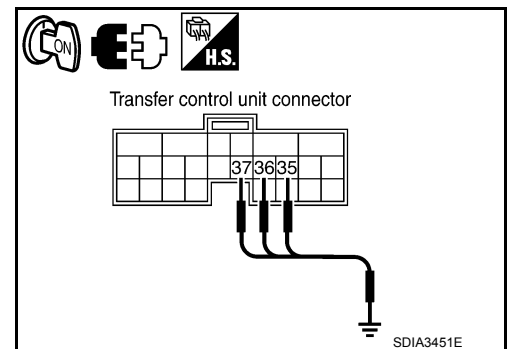
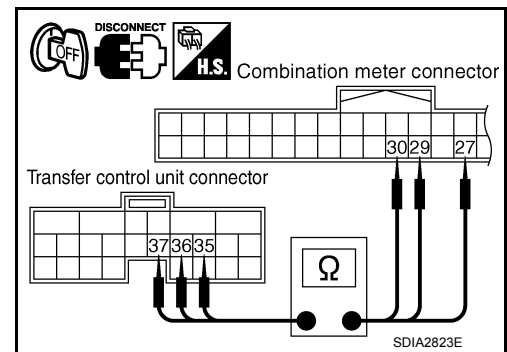

4WD SHIFT INDICATOR LAMP OR 4LO INDICATOR LAMP DO NOT CHANGE

Description

INFOID:000000007323913

4WD shift indicator lamp or 4LO indicator lamp do not change when switching the 4WD shift switch.

Diagnosis Procedure

INFOID:000000007323914

1.CONFIRM THE SYMPTOM

Confirm 4WD shift indicator lamp and 4LO indicator lamp when ignition switch is turned to ON.

Do 4WD shift indicator lamp and 4LO indicator lamp turn on?

YES-1 (A/T models)>>GO TO 2.

YES-2 (M/T models)>>GO TO 3.

NO >> Go to [DLN-75, "Diagnosis Procedure"](#).

2.CHECK SYSTEM FOR STOP LAMP SWITCH

Perform trouble diagnosis for stop lamp switch system. Refer to [BRC-51, "Diagnosis Procedure"](#) (Type 1) or [BRC-170, "Diagnosis Procedure"](#) (Type 2).

Are the inspection results normal?

YES >> GO TO 3.

NO >> Repair or replace damaged parts.

3.CHECK SYSTEM FOR 4WD SHIFT SWITCH

Perform trouble diagnosis for 4WD shift switch system. Refer to [DLN-31, "Diagnosis Procedure"](#).

Are the inspection results normal?

YES >> GO TO 4.

NO >> Repair or replace damaged parts.

4.CHECK SYSTEM FOR WAIT DETECTION SWITCH

Perform trouble diagnosis for wait detection switch system. Refer to [DLN-34, "Diagnosis Procedure"](#).

Are the inspection results normal?

YES >> GO TO 5.

NO >> Repair or replace damaged parts.

5.CHECK SYSTEM FOR 4LO SWITCH

Perform trouble diagnosis for 4LO switch system. Refer to [DLN-28, "Diagnosis Procedure"](#).

Are the inspection results normal?

YES-1 (A/T models)>>GO TO 6.

YES-2 (M/T models)>>GO TO 7.

NO >> Repair or replace damaged parts.

6.CHECK SYSTEM FOR ATP SWITCH

Perform trouble diagnosis for ATP switch system. Refer to [DLN-83, "Diagnosis Procedure"](#).

Are the inspection results normal?

YES >> GO TO 7.

NO >> Repair or replace damaged parts.

7.SYMPTOM CHECK

Check again.

Does the symptom still occur?

YES >> GO TO 8.

NO >> Inspection End.

8.CHECK TRANSFER CONTROL UNIT

Check transfer control unit input/output signal. Refer to [DLN-56, "Reference Value"](#).

A
B
C
DLN
E
F
G
H
I
J
K
L
M
N
O
P

4WD SHIFT INDICATOR LAMP OR 4LO INDICATOR LAMP DO NOT CHANGE

< SYMPTOM DIAGNOSIS >

[TRANSFER: TX15B]

Are the inspection results normal?

YES >> GO TO 9.

NO >> Check transfer control unit pin terminals for damage or loose connection with harness connector.
If any items are damaged, repair or replace damaged parts.

9. CHECK TRANSFER INNER PARTS

1. Disassemble transfer assembly. Refer to [DLN-107, "Disassembly and Assembly"](#).

2. Check transfer inner parts.

Are the inspection results normal?

YES >> Inspection End.

NO >> Repair or replace damaged parts.

ATP WARNING LAMP DOES NOT TURN ON

< SYMPTOM DIAGNOSIS >

[TRANSFER: TX15B]

ATP WARNING LAMP DOES NOT TURN ON

Description

INFOID:000000007323915

ATP warning lamp does not turn ON when the transfer case is switched in or out of 4LO with the A/T selector lever in N position.

Diagnosis Procedure

INFOID:000000007323916

Regarding Wiring Diagram information, refer to [DLN-63, "Wiring Diagram"](#).

1. CHECK SYSTEM FOR CAN COMMUNICATION LINE

Perform self-diagnosis. Refer to [DLN-17, "CONSULT Function \(ALL MODE AWD/4WD\)"](#).

Do the self-diagnostic results indicate CAN communication?

- YES >> Perform trouble diagnosis for CAN communication line. Refer to [DLN-60, "DTC Index"](#).
- NO >> GO TO 2.

2. CHECK SYSTEM FOR 4WD SHIFT SWITCH

Perform trouble diagnosis for 4WD shift switch system. Refer to [DLN-31, "Diagnosis Procedure"](#).

Are the inspection results normal?

- YES >> GO TO 3.
- NO >> Repair or replace damaged parts.

3. CHECK SYSTEM FOR TRANSMISSION RANGE (A/T MODELS) OR PNP (M/T MODELS) SWITCH SIGNAL

Perform trouble diagnosis for transmission range (A/T models) or PNP (M/T models) switch signal system. Refer to [DLN-37, "Diagnosis Procedure"](#) (A/T models) or [DLN-38, "Diagnosis Procedure"](#) (M/T models).

Are the inspection results normal?

- YES >> GO TO 4.
- NO >> Repair or replace damaged parts.

4. CHECK SYSTEM FOR ATP SWITCH

Perform trouble diagnosis for ATP switch system. Refer to [DLN-83, "Diagnosis Procedure"](#).

Are the inspection results normal?

- YES >> GO TO 5.
- NO >> Repair or replace damaged parts.

5. CHECK ATP WARNING LAMP CIRCUIT

1. Disconnect ATP switch harness connector.
2. Turn ignition switch "ON". (Do not start engine.)
3. Ground terminal 8 on ATP switch connector F55 using suitable wiring.
4. Turn ignition switch "OFF". (Stay for at least 5 seconds.)

Does ATP warning lamp turn on?

- YES >> GO TO 9.
- NO >> GO TO 6.

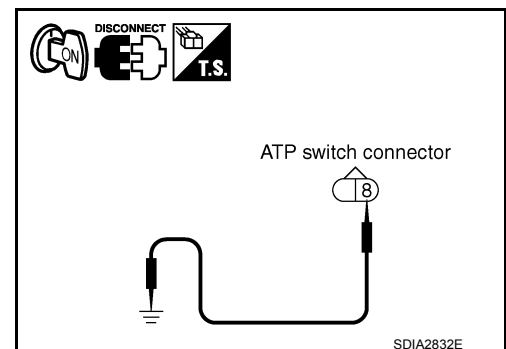

6. CHECK HARNESS BETWEEN TRANSFER CONTROL UNIT AND COMBINATION METER

1. Turn ignition switch "OFF". (Stay for at least 5 seconds.)
2. Disconnect transfer control unit harness connector and combination meter harness connector.

ATP WARNING LAMP DOES NOT TURN ON

< SYMPTOM DIAGNOSIS >

[TRANSFER: TX15B]

3. Check continuity between transfer control unit harness connector M153 terminal 39 and combination meter harness connector M24 terminal 21.

Continuity should exist.

Also check harness for short to ground and short to power.

Does continuity exist?

- YES >> GO TO 7.
NO >> Repair or replace damaged parts.

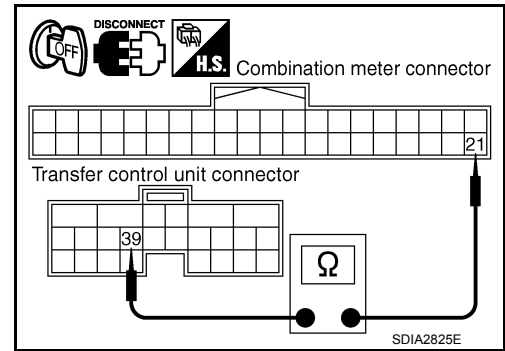

7. CHECK HARNESS BETWEEN COMBINATION METER AND ATP SWITCH

1. Turn ignition switch "OFF". (Stay for at least 5 seconds.)
2. Disconnect ATP switch harness connector.
3. Check continuity between combination meter harness connector M24 terminal 1 and ATP switch harness connector F55 terminal 8.

Continuity should exist.

Also check harness for short to ground and short to power.

Does continuity exist?

- YES >> GO TO 8.
NO >> Repair or replace damaged parts.

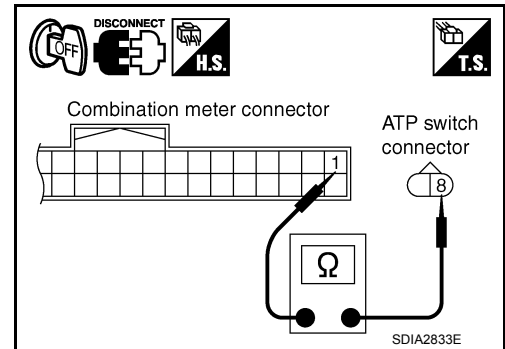

8. SYMPTOM CHECK

Check again.

Does the symptom still occur?

- YES >> GO TO 9.
NO >> Inspection End.

9. CHECK TRANSFER CONTROL UNIT

Check transfer control unit input/output signal. Refer to [DLN-56, "Reference Value"](#).

Are the inspection results normal?

- YES >> GO TO 10.
NO >> Check transfer control unit pin terminals for damage or loose connection with harness connector.
If any items are damaged, repair or replace damaged parts.

10. CHECK TRANSFER INNER PARTS

1. Disassemble transfer assembly. Refer to [DLN-107, "Disassembly and Assembly"](#).
2. Check transfer inner parts.

Are the inspection results normal?

- YES >> Inspection End.
NO >> Repair or replace damaged parts.

4WD SHIFT INDICATOR LAMP KEEPS FLASHING

< SYMPTOM DIAGNOSIS >

[TRANSFER: TX15B]

4WD SHIFT INDICATOR LAMP KEEPS FLASHING

Description

INFOID:000000007323917

The 4WD shift indicator lamp keeps flashing.

Diagnosis Procedure

INFOID:000000007323918

1.CONFIRM THE SYMPTOM

1. Set 4WD shift switch to "2WD".
2. Drive the vehicle straight forward and backward keeping speed under 20 km/h (12 MPH).

Does 4WD shift indicator lamp keep flashing?

- YES >> GO TO 2.
NO >> Inspection End.

2.CHECK SYSTEM FOR WAIT DETECTION SWITCH

Perform trouble diagnosis for wait detection switch system. Refer to [DLN-34, "Diagnosis Procedure"](#).

Are the inspection results normal?

- YES >> GO TO 3.
NO >> Repair or replace damaged parts.

3.CHECK SYSTEM FOR 4LO SWITCH

Perform trouble diagnosis for 4LO switch. Refer to [DLN-28, "Diagnosis Procedure"](#).

Are the inspection results normal?

- YES >> GO TO 4.
NO >> Repair or replace damaged parts.

4.SYMPTOM CHECK

Check again.

Does the symptom still occur?

- YES >> GO TO 5.
NO >> Inspection End.

5.CHECK TRANSFER CONTROL UNIT

Check transfer control unit input/output signal. Refer to [DLN-56, "Reference Value"](#).

Are the inspection results normal?

- YES >> GO TO 6.
NO >> Check transfer control unit pin terminals for damage or loose connection with harness connector.
If any items are damaged, repair or replace damaged parts.

6.CHECK TRANSFER INNER PARTS

1. Disassemble transfer assembly. Refer to [DLN-107, "Disassembly and Assembly"](#).
2. Check transfer inner parts.

Are the inspection results normal?

- YES >> Inspection End.
NO >> Repair or replace damaged parts.

A
B
C
DLN
E
F
G
H
I
J
K
L
M
N
O
P

4WD WARNING LAMP FLASHES SLOWLY

< SYMPTOM DIAGNOSIS >

[TRANSFER: TX15B]

4WD WARNING LAMP FLASHES SLOWLY

Description

INFOID:000000007323919

The 4WD warning lamp flashes slowly while driving (1 time / 2 seconds). The lamp continues to flash until the ignition switch is turned OFF.

Diagnosis Procedure

INFOID:000000007323920

1. CHECK TIRES

Check the following. Refer to [WT-52, "Tire"](#).

- Tire size
- Tire wear
- Tire pressure

Are the inspection results normal?

YES >> GO TO 2.

NO >> Repair or replace damaged parts.

2. SYMPTOM CHECK

Check again.

Does the symptom still occur?

YES >> GO TO 3.

NO >> Inspection End.

3. CHECK TRANSFER CONTROL UNIT

Check transfer control unit input/output signal. Refer to [DLN-56, "Reference Value"](#).

Are the inspection results normal?

YES >> Inspection End.

NO >> Check transfer control unit pin terminals for damage or loose connection with harness connector.
If any items are damaged, repair or replace damaged parts.

ATP SWITCH

< SYMPTOM DIAGNOSIS >

[TRANSFER: TX15B]

ATP SWITCH

Description

INFOID:000000007323921

The ATP indicator does not come on when the transfer is in neutral and the A/T lever is in neutral or, the ATP indicator stays on when the transfer case is not in neutral.

Diagnosis Procedure

INFOID:000000007323922

Regarding Wiring Diagram information, refer to [DLN-63, "Wiring Diagram"](#).

1. CHECK ATP SWITCH SIGNAL

With CONSULT

1. Start engine.
2. Select "DATA MONITOR" mode for "ALL MODE AWD/4WD" with CONSULT.
3. Read out the value of "ATP SWITCH".

Condition		Display value
<ul style="list-style-type: none"> • Vehicle stopped • Engine running • A/T selector lever "N" position • Brake pedal depressed 	4WD shift switch: 4H to 4LO or 4LO to 4H (While actuator motor is operating.)	ON
Except the above		OFF

Without CONSULT

1. Start engine.
2. Check voltage between transfer control unit harness connector terminal and ground.

Connector	Terminal	Condition		Voltage (Approx.)
M152	23 - Ground	<ul style="list-style-type: none"> • Vehicle stopped • Engine running • A/T selector lever "N" position • Brake pedal depressed 	4WD shift switch: 4H to 4LO or 4LO to 4H (While actuator motor is operating.)	0V
		Except the above		Battery voltage

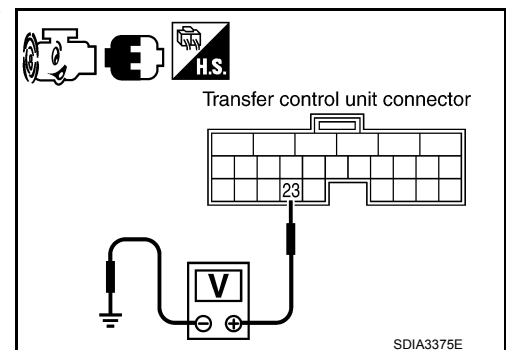

Are the inspection results normal?

- YES >> GO TO 5.
NO >> GO TO 2.

2. CHECK HARNESS BETWEEN TRANSFER CONTROL UNIT AND ATP SWITCH

1. Turn ignition switch "OFF". (Stay for at least 5 seconds.)
2. Disconnect transfer control unit harness connector and the ATP switch harness connector.

ATP SWITCH

[TRANSFER: TX15B]

< SYMPTOM DIAGNOSIS >

3. Check continuity between transfer control unit harness connector M152 terminal 23 and ATP switch harness connector F55 terminal 8.

Continuity should exist.

Also check harness for short to ground and short to power.

Does continuity exist?

- YES >> GO TO 3.
NO >> Repair or replace damaged parts.

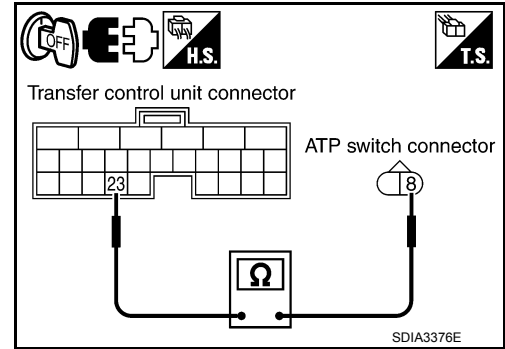

3.CHECK GROUND CIRCUIT

1. Turn ignition switch "OFF". (Stay for at least 5 seconds.)
2. Disconnect ATP switch harness connector.
3. Check continuity between ATP switch harness connector F55 terminal 9 and ground.

Continuity should exist.

Also check harness for short to power.

Does continuity exist?

- YES >> GO TO 4.
NO >> Repair open circuit or short to power in harness or connectors.

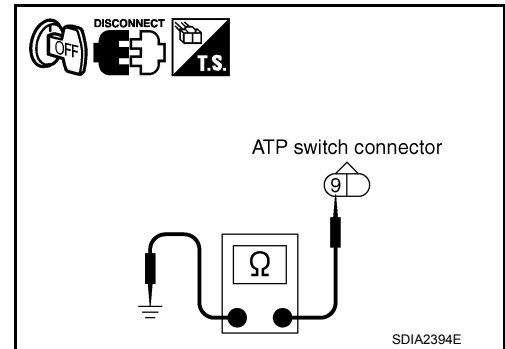

4.CHECK ATP SWITCH

1. Turn ignition switch "OFF". (Stay for at least 5 seconds.)
2. Remove ATP switch. Refer to [DLN-13, "Component Parts Location"](#).
3. Push and release ATP switch and check continuity between ATP switch terminals 8 and 9.

Terminal	Condition	Continuity
8 - 9	Push ATP switch	Yes
	Release ATP switch	No

Are the inspection results normal?

- YES >> GO TO 5.
NO >> Replace ATP switch.

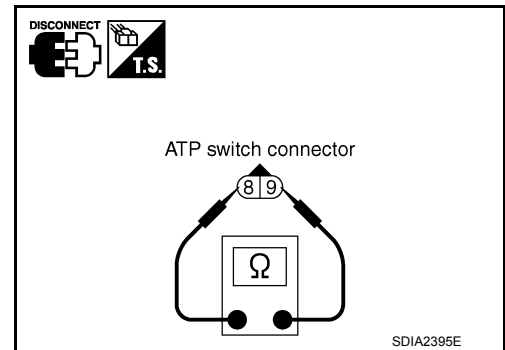

5.CHECK TRANSFER CONTROL UNIT

Check transfer control unit input/output signal. Refer to [DLN-56, "Reference Value"](#).

Are the inspection results normal?

- YES >> GO TO 6.
NO >> Check transfer control unit pin terminals for damage or loose connection with harness connector. If any items are damaged, repair or replace damaged parts.

6.CHECK ATP WARNING LAMP

1. Turn ignition switch "ON". (Do not start engine.)
2. A/T selector lever "N" position and engage the parking brake.
3. Switch 4WD shift switch from 4H to 4LO or 4LO to 4H.

Does the ATP warning lamp turn ON while the actuator motor is operating?

- YES >> Inspection End.
NO >> Refer to [DLN-79, "Diagnosis Procedure"](#).

ATP SWITCH

< SYMPTOM DIAGNOSIS >

[TRANSFER: TX15B]

Component Inspection

INFOID:000000007323923

1. Turn ignition switch "OFF". (Stay for at least 5 seconds.)
2. Disconnect ATP switch harness connector.
3. Remove ATP switch. Refer to [DLN-13, "Component Parts Location"](#).
4. Push and release ATP switch and check continuity between ATP switch terminals 8 and 9.

Terminal	Condition	Continuity
8 - 9	Push ATP switch	Yes
	Release ATP switch	No

5. If the inspection results are abnormal replace the ATP switch.

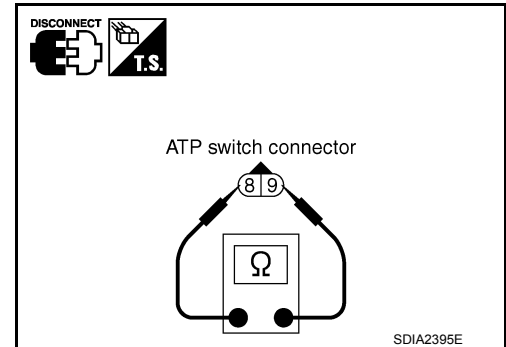

A
B
C
DLN
E
F
G
H
I
J
K
L
M
N
O
P

PRECAUTION

PRECAUTIONS

Precaution for Supplemental Restraint System (SRS) "AIR BAG" and "SEAT BELT PRE-TENSIONER"

INFOID:000000007323924

The Supplemental Restraint System such as "AIR BAG" and "SEAT BELT PRE-TENSIONER", used along with a front seat belt, helps to reduce the risk or severity of injury to the driver and front passenger for certain types of collision. This system includes seat belt switch inputs and dual stage front air bag modules. The SRS system uses the seat belt switches to determine the front air bag deployment, and may only deploy one front air bag, depending on the severity of a collision and whether the front occupants are belted or unbelted. Information necessary to service the system safely is included in the SR and SB section of this Service Manual.

WARNING:

- To avoid rendering the SRS inoperative, which could increase the risk of personal injury or death in the event of a collision which would result in air bag inflation, all maintenance must be performed by an authorized NISSAN/INFINITI dealer.
- Improper maintenance, including incorrect removal and installation of the SRS, can lead to personal injury caused by unintentional activation of the system. For removal of Spiral Cable and Air Bag Module, see the SR section.
- Do not use electrical test equipment on any circuit related to the SRS unless instructed to in this Service Manual. SRS wiring harnesses can be identified by yellow and/or orange harnesses or harness connectors.

PRECAUTIONS WHEN USING POWER TOOLS (AIR OR ELECTRIC) AND HAMMERS

WARNING:

- When working near the Airbag Diagnosis Sensor Unit or other Airbag System sensors with the Ignition ON or engine running, DO NOT use air or electric power tools or strike near the sensor(s) with a hammer. Heavy vibration could activate the sensor(s) and deploy the air bag(s), possibly causing serious injury.
- When using air or electric power tools or hammers, always switch the Ignition OFF, disconnect the battery, and wait at least 3 minutes before performing any service.

Precaution for Transfer Assembly and Transfer Control Unit Replacement

INFOID:000000007323925

When replacing transfer assembly or transfer control unit, check the 4WD shift indicator pattern and adjustment of the position between transfer assembly and transfer control unit if necessary.





CHECK 4WD SHIFT INDICATOR PATTERN

1. Set 4WD shift switch to "2WD", "4H", "4LO", "4H" and "2WD" in order. Stay at each switch position for at least 2 seconds.
2. Confirm 4WD shift indicator lamp and 4LO indicator lamp change properly as follows.

PRECAUTIONS

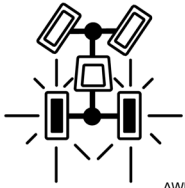
< PRECAUTION >

[TRANSFER: TX15B]

4WD shift switch	Indicator lamp		Operation of 4WD shift switch
	4WD shift	4LO	
2WD	 AWDIA0872ZZ	OFF	2WD ⇔ 4H switching can be done while driving. The indicator lamp will change when the driving mode is changed. Gear shifting between 2WD ⇔ 4H position must be performed at speeds below 100 km/h (60 MPH).
4H	 AWDIA0873ZZ		
4LO	 AWDIA0873ZZ	Flashing	For M/T models, to shift between 4H ⇔ 4LO, stop the vehicle and shift the transmission shift selector to the Neutral position with the clutch pedal depressed. For A/T models, to shift between 4H ⇔ 4LO, stop vehicle and shift transmission shift selector to the "N" position with brake pedal depressed.
	 AWDIA0873ZZ	ON	The 4WD shift switch will not shift to the desired mode if the transmission is not in "N" or the vehicle is moving. You must wait for the 4LO indicator lamp to stop flashing and remain lit or turned off before shifting your transmission into gear or releasing the clutch pedal.

- If OK, the position between transfer assembly and transfer control unit is correct.
- If NG, the position is different between transfer assembly and transfer control unit. Adjust the position between transfer assembly and transfer control unit. Refer to pattern table below.

Transfer position adjustment pattern

4WD shift switch condition	Refer procedure
4WD shift switch is in "2WD" when engine is stopped.	"METHOD FOR ADJUSTMENT WITH 4WD SHIFT SWITCH AT "2WD""
4WD shift switch is in "4H" or "4LO" when engine is stopped.	"METHOD FOR ADJUSTMENT WITH 4WD SHIFT SWITCH AT "4H" OR "4LO""

NOTE:

Method of adjustment can be chosen voluntarily, according to location of 4WD shift switch.

METHOD FOR ADJUSTMENT WITH 4WD SHIFT SWITCH AT "2WD"

Select Adjustment Pattern

1. Start engine. Run engine for at least 10 seconds.
2. Check 4WD shift indicator lamp and 4LO indicator lamp.

Indicator lamp condition	Refer procedure
When 4WD shift indicator lamp or 4LO indicator lamp is flashing.	"Pattern A"
Except for above.	"Pattern B"

PRECAUTIONS

[TRANSFER: TX15B]

< PRECAUTION >

Pattern A

1. Shift the transmission according to the directions below, and stay in "N" for at least 2 seconds.
 - For A/T models, stop vehicle and move A/T shift selector to "N" position with brake pedal depressed.
 - For M/T models, stop vehicle and move M/T shift selector to the neutral position with brake and clutch pedal depressed.
2. Turn 4WD shift switch to "4LO" position. Stay in "4LO" for at least 2 seconds.
3. Turn ignition switch "OFF".
4. Start engine.
5. Erase self-diagnosis. Refer to [DLN-17, "CONSULT Function \(ALL MODE AWD/4WD\)"](#).
6. Check 4WD shift indicator lamp and 4LO indicator lamp again. Refer to "CHECK 4WD SHIFT INDICATOR PATTERN".
If 4WD shift indicator lamp and 4LO indicator lamp do not indicate proper pattern, install new transfer control unit and retry the above check.

Pattern B

1. Shift the transmission according to the directions below, and stay in "N" for at least 2 seconds.
 - For A/T models, stop vehicle and move A/T shift selector to "N" position with brake pedal depressed.
 - For M/T models, stop vehicle and move M/T shift selector to the neutral position with brake and clutch pedal depressed.
2. Turn ignition switch "OFF".
3. Start engine.
4. Erase self-diagnosis. Refer to [DLN-17, "CONSULT Function \(ALL MODE AWD/4WD\)"](#).
5. Check 4WD shift indicator lamp and 4LO indicator lamp again. Refer to "CHECK 4WD SHIFT INDICATOR PATTERN".
If 4WD shift indicator lamp and 4LO indicator lamp do not indicate proper pattern, install new transfer control unit and retry the above check.

METHOD FOR ADJUSTMENT WITH 4WD SHIFT SWITCH AT "4H" OR "4LO"

1. Start engine. Run the engine for at least 10 seconds.
2. Shift the transmission according to the directions below, and stay in "N" for at least 2 seconds.
 - For A/T models, stop vehicle and move A/T shift selector to "N" position with brake pedal depressed.
 - For M/T models, stop vehicle and move M/T shift selector to the neutral position with brake and clutch pedal depressed.
3. Turn 4WD shift switch to "2WD" position. Stay in "2WD" for at least 2 seconds.
4. Turn ignition switch "OFF".
5. Start engine.
6. Erase self-diagnosis. Refer to [DLN-17, "CONSULT Function \(ALL MODE AWD/4WD\)"](#).
7. Check 4WD shift indicator lamp and 4LO indicator lamp again. Refer to "CHECK 4WD SHIFT INDICATOR PATTERN".
If 4WD shift indicator lamp and 4LO indicator lamp do not indicate proper pattern, install new transfer control unit and retry the above check.

Precaution

INFOID:000000007323926

- **Before connecting or disconnecting the transfer control unit harness connector, turn ignition switch "OFF" and disconnect the battery cables. Battery voltage is applied to transfer control unit even if ignition switch is turned "OFF".**

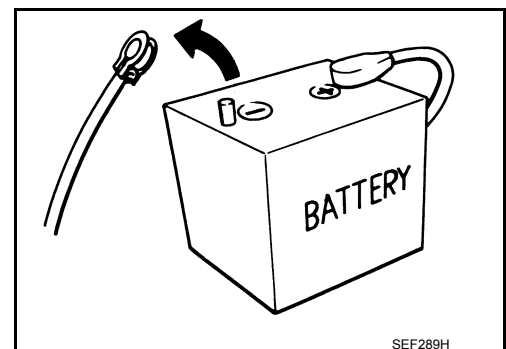

SEF289H

PRECAUTIONS

< PRECAUTION >

[TRANSFER: TX15B]

- When connecting or disconnecting pin connectors into or from transfer control unit, take care not to damage pin terminals (bend or break).
When connecting pin connectors make sure that there are not any bends or breaks on transfer control unit pin terminals.

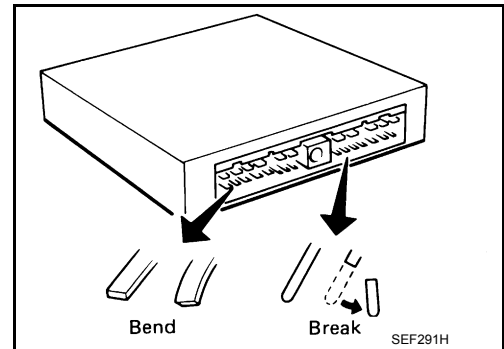

- Before replacing transfer control unit, perform transfer control unit input/output signal inspection and make sure transfer control unit functions properly. Refer to [DLN-56, "Reference Value"](#).

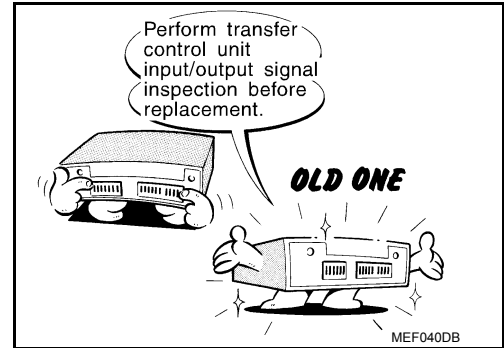

Service Notice

INFOID:000000007323927

- After overhaul refill the transfer with new transfer fluid.
- Check the fluid level or replace the fluid only with the vehicle parked on level ground.
- During removal or installation, keep inside of transfer clear of dust or dirt.
- Disassembly should be done in a clean work area.
- Before proceeding with disassembly, thoroughly clean the transfer. It is important to prevent the internal parts from becoming contaminated by dirt or other foreign matter.
- Check for the correct installation status prior to removal or disassembly. If matchmarks are required, be certain they do not interfere with the function of the parts when applied.
- All parts should be carefully cleaned with a general purpose, non-flammable solvent before inspection or reassembly.
- Check appearance of the disassembled parts for damage, deformation, and unusual wear. Replace them with a new ones if necessary.
- Gaskets, seals and O-rings should replaced any time the transfer is disassembled.
- In principle, tighten bolts or nuts gradually in several steps working diagonally from inside to outside. If tightening sequence is specified, use it.
- Observe the specified torque when assembling.
- Clean and flush the parts sufficiently and blow-dry them.
- Be careful not to damage sliding surfaces and mating surfaces.
- Use lint-free cloth or towels for wiping parts clean. Common shop rags can leave fibers that could interfere with the operation of the transfer.

A
B
C
DLN
E
F
G
H
I
J
K
L
M
N
O
P

PREPARATION

< PREPARATION >

[TRANSFER: TX15B]

PREPARATION

PREPARATION

Special Service Tool

INFOID:000000007323928

The actual shapes of Kent-Moore tools may differ from those of special service tools illustrated here.

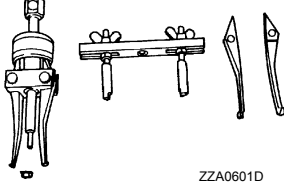
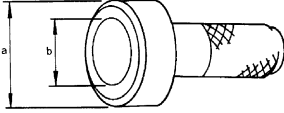
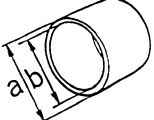
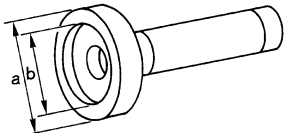
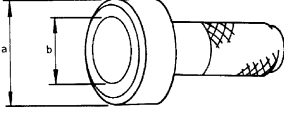
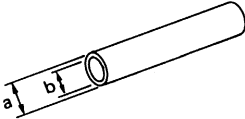
Tool number (Kent-Moore No.) Tool name	Description
ST33290001 (J-34286) Puller	 <p style="text-align: center;">ZZA0601D</p> <ul style="list-style-type: none"> • Removing front oil seal • Removing rear oil seal • Removing metal bushing
KV38100500 (—) Drift	 <p style="text-align: center;">ZZA0811D</p> <ul style="list-style-type: none"> • Installing front oil seal • Installing rear oil seal • Installing rear bearing • Installing front bearing <p>a: 80 mm (3.15 in) dia. b: 60 mm (2.36 in) dia.</p>
KV40105310 (—) Drift	 <p style="text-align: center;">ZZA1003D</p> <ul style="list-style-type: none"> • Installing dust cover <p>a: 89 mm (3.50 in) dia. b: 80.7 mm (3.17 in) dia.</p>
KV38100200 (—) Drift	 <p style="text-align: center;">ZZA1143D</p> <ul style="list-style-type: none"> • Removing sun gear assembly and planetary carrier assembly • Removing input bearing • Installing sun gear assembly and planetary carrier assembly <p>a: 65 mm (2.56 in) dia. b: 49 mm (1.93 in) dia.</p>
ST30720000 (J-25405) Drift	 <p style="text-align: center;">ZZA0811D</p> <ul style="list-style-type: none"> • Installing input bearing • Installing input oil seal • Installing carrier bearing <p>a: 77 mm (3.03 in) dia. b: 55 mm (2.17 in) dia.</p>
KV32102700 (—) Drift	 <p style="text-align: center;">ZZA0534D</p> <ul style="list-style-type: none"> • Installing mainshaft rear bearing <p>a: 48 mm (1.89 in) dia. b: 41 mm (1.61 in) dia.</p>

PREPARATION

< PREPARATION >

[TRANSFER: TX15B]

Tool number (Kent-Moore No.) Tool name	Description	
KV40104830 (—) Drift	<ul style="list-style-type: none"> Installing input oil seal a: 70 mm (2.76 in) dia. b: 63.5 mm (2.50 in) dia. 	A B C
ST35300000 (—) Drift	<ul style="list-style-type: none"> Removing carrier bearing Installing metal bushing Removing front bearing a: 59 mm (2.32 in) dia. b: 45 mm (1.77 in) dia. 	DLN E F
ST30021000 (J-22912-01) Puller	<ul style="list-style-type: none"> Removing carrier bearing Removing front bearing Removing rear bearing 	G H
ST33710000 (—) Drift	<ul style="list-style-type: none"> Removing needle bearing Removing metal bushing Removing rear bearing a: 89 mm (3.5 in) b: 30 mm (1.18 in) dia. c: 24 mm (0.94 in) dia. 	I J
ST35325000 (—) Drift bar	<ul style="list-style-type: none"> Removing metal bushing a: 215 mm (8.46 in) b: 25 mm (0.98 in) dia. c: M12 × 1.5P 	K L M
ST33220000 (—) Drift	<ul style="list-style-type: none"> Installing needle bearing a: 37 mm (1.46 in) dia. b: 31 mm (1.22 in) dia. c: 22 mm (0.87 in) dia. 	N O P

PREPARATION

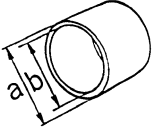
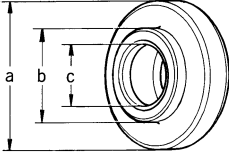

< PREPARATION >

[TRANSFER: TX15B]

Tool number (Kent-Moore No.) Tool name	Description
ST27863000 (—) Drift	<ul style="list-style-type: none"> • Installing carrier bearing a: 75 mm (2.95 in) dia. b: 62 mm (2.44 in) dia.
 ZZA1003D	
ST30901000 (J-26010-01) Drift	<ul style="list-style-type: none"> • Installing rear bearing • Installing front bearing a: 79 mm (3.11 in) dia. b: 45 mm (1.77 in) dia. c: 35.2 mm (1.38 in) dia.
 ZZA0978D	

Commercial Service Tool

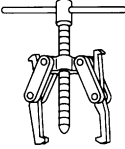
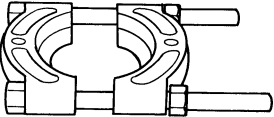
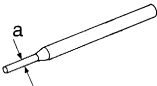
INFOID:000000007323929

Tool name	Description
Puller	<ul style="list-style-type: none"> • Removing companion flange • Removing mainshaft rear bearing
 NT077	
Puller	Removing mainshaft rear bearing
 ZZB0823D	
Pin punch	Removing retaining pin a: 6 mm (0.24 in) dia.
 NT410	
Power tool	Loosening nuts, screws and bolts
 PIIB1407E	

PERIODIC MAINTENANCE

TRANSFER FLUID

Replacement

INFOID:000000007323930

CAUTION:

If using the vehicle for towing, the transfer fluid must be replaced as specified. Refer to [MA-11, "FOR USA AND CANADA : Periodic Maintenance"](#) (United States and Canada) or [MA-15, "FOR MEXICO : Periodic Maintenance"](#) (Mexico).

DRAINING

1. Stop engine.
2. Remove the drain plug and gasket and drain the fluid.
3. Install the drain plug with a new gasket to the transfer. Tighten to the specified torque. Refer to [DLN-106, "Exploded View"](#).

CAUTION:

Do not reuse gasket.

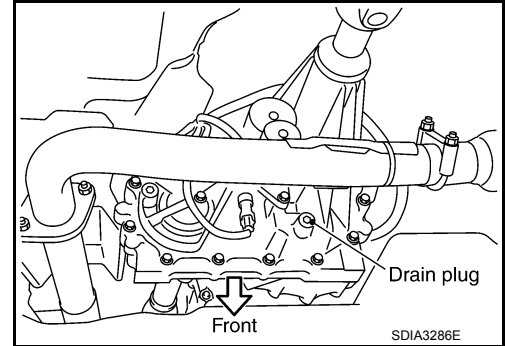

FILLING

1. Remove the filler plug and gasket.
2. Fill the transfer with new fluid until the fluid level reaches the specified limit near the filler plug hole.

Fluid grade and capacity : Refer to [MA-18, "FOR USA AND CANADA : Fluids and Lubricants"](#) (United States and Canada) and [MA-20, "FOR MEXICO : Fluids and Lubricants"](#) (Mexico).

CAUTION:

Carefully fill fluid. (Fill up for approx. 3 minutes.)

3. Leave the vehicle for 3 minutes, and check fluid level again.
4. Install the filler plug with a new gasket to the transfer. Tighten to the specified torque. Refer to [DLN-106, "Exploded View"](#).

CAUTION:

Do not reuse gasket.

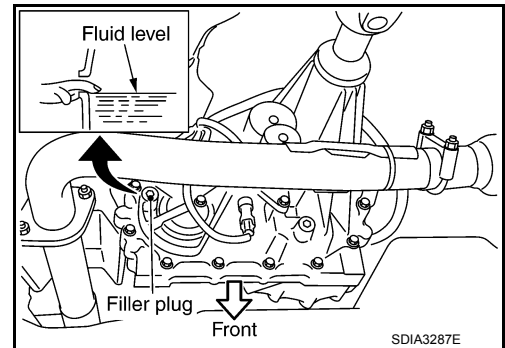

Inspection

INFOID:000000007323931

CAUTION:

If using the vehicle for towing, the transfer fluid must be replaced as specified. Refer to [MA-11, "FOR USA AND CANADA : Periodic Maintenance"](#) (United States and Canada) and [MA-15, "FOR MEXICO : Periodic Maintenance"](#) (Mexico).

FLUID LEAKAGE AND FLUID LEVEL

1. Make sure that fluid is not leaking from the transfer assembly or around it.

A
B
C
DLN
E
F
G
H
I
J
K
L
M
N
O
P

TRANSFER FLUID

< PERIODIC MAINTENANCE >

[TRANSFER: TX15B]

2. Check fluid level from the filler plug hole as shown.
CAUTION:
Do not start engine while checking fluid level.
3. Install the filler plug with a new gasket to the transfer. Tighten to the specified torque. Refer to [DLN-106, "Exploded View"](#).
CAUTION:
Do not reuse gasket.

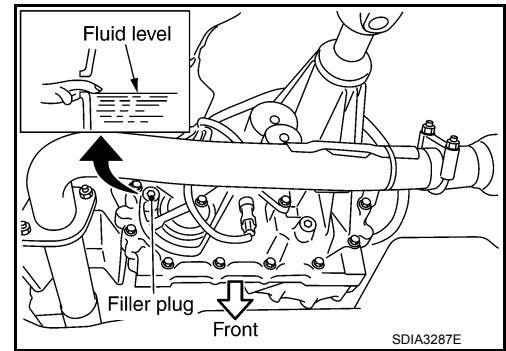

TRANSFER CONTROL UNIT

< REMOVAL AND INSTALLATION >

[TRANSFER: TX15B]

REMOVAL AND INSTALLATION

TRANSFER CONTROL UNIT

Removal and Installation

INFOID:000000007323932

REMOVAL

1. Switch 4WD shift switch to 2WD and set transfer assembly to 2WD.

CAUTION:

When removing transfer control unit, transfer state must be at 2WD.

2. Turn the ignition switch OFF and disconnect negative battery terminal.
3. Remove the instrument lower panel LH. Refer to [IP-18. "Removal and Installation"](#).
4. Disconnect the two transfer control unit connectors.
5. Remove the transfer control unit bolts.
6. Remove the transfer control unit.

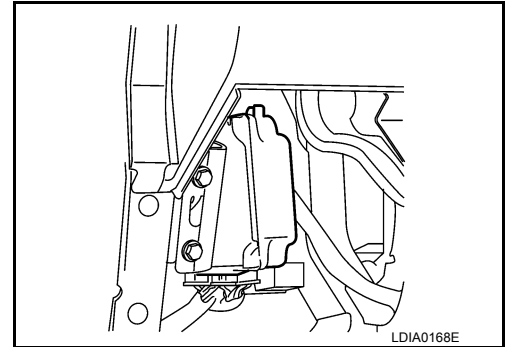

INSTALLATION

Installation is in the reverse order of removal.

- When installing the transfer control unit, tighten bolts to the specified torque.

Transfer control unit bolts : 3.4 N·m (0.35 kg-m, 30 in-lb)

- After the installation, check 4WD shift indicator pattern. If NG, adjust position between transfer assembly and transfer control unit. Refer to [DLN-86. "Precaution for Transfer Assembly and Transfer Control Unit Replacement"](#).

FRONT OIL SEAL

< REMOVAL AND INSTALLATION >

[TRANSFER: TX15B]

FRONT OIL SEAL

Removal and Installation

INFOID:000000007323933

REMOVAL

1. Remove the front propeller shaft. Refer to [DLN-137, "Removal and Installation"](#).
2. Remove the companion flange self-lock nut using suitable tool.

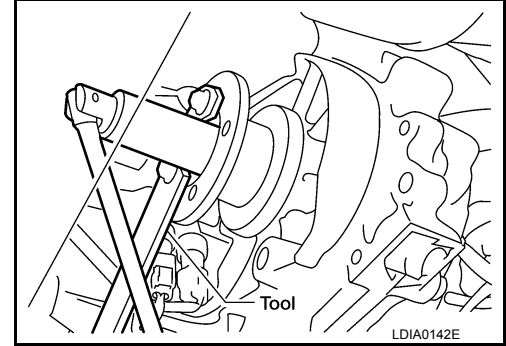

3. Put a matching mark on top of the front drive shaft in line with the mark on the companion flange.

CAUTION:

Use paint to make the matching mark on the front drive shaft. Do not damage the front drive shaft.

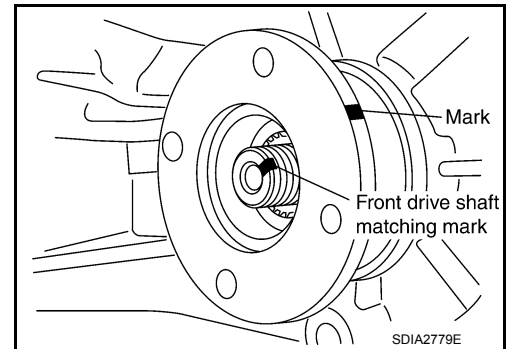

4. Remove the companion flange using suitable tool.

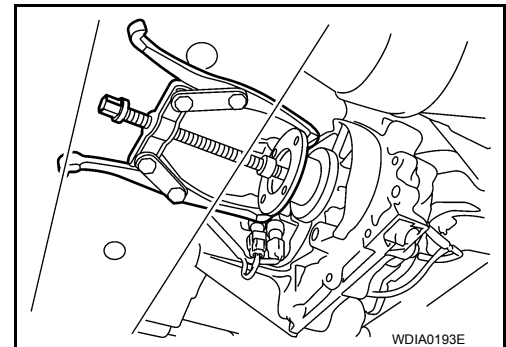

5. Remove the front oil seal from the front case using Tool.

Tool number : ST33290001 (J-34286)

CAUTION:

Do not damage front case.

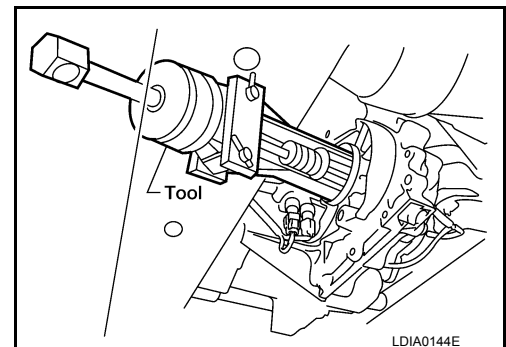

INSTALLATION

FRONT OIL SEAL

< REMOVAL AND INSTALLATION >

[TRANSFER: TX15B]

1. Install the new front oil seal until it is flush with the end face of the front case using Tool.

Tool number : KV38100500 (—)

CAUTION:

- Do not reuse oil seal.
- Apply petroleum jelly to oil seal.

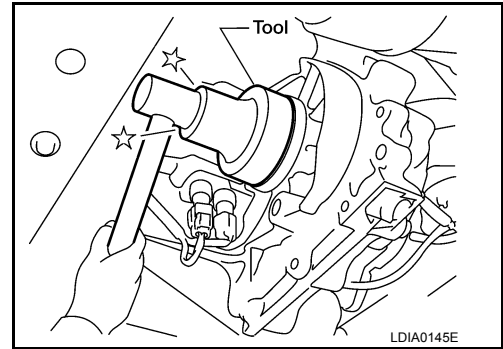

2. Align the matching mark of the front drive shaft with the matching mark of the companion flange, then install the companion flange.

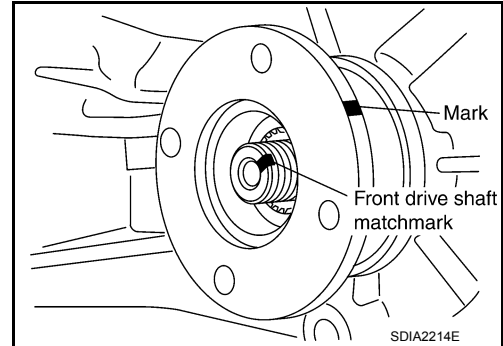

3. Install the new self-lock nut and tighten to the specified torque using suitable tool. Refer to [DLN-106. "Exploded View"](#).

CAUTION:

Do not reuse self-lock nut.

4. Install the front propeller shaft. Refer to [DLN-137. "Removal and Installation"](#).
5. Check the transfer fluid level and refill as necessary. Refer to [DLN-93. "Inspection"](#).

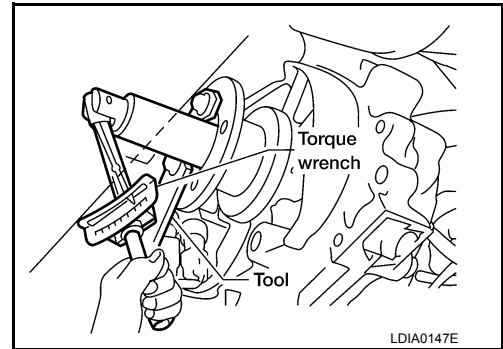

A
B
C
DLN
E
F
G
H
I
J
K
L
M
N
O
P

REAR OIL SEAL

< REMOVAL AND INSTALLATION >

[TRANSFER: TX15B]

REAR OIL SEAL

Removal and Installation

INFOID:000000007323934

REMOVAL

1. Remove the rear propeller shaft. Refer to [DLN-146. "Removal and Installation"](#) (2S1330) or [DLN-177. "Removal and Installation"](#) (3S1330-2BJ100).
2. Remove the dust cover from the rear case.
CAUTION:
Do not damage the rear case.
3. Remove the oil cover from the dust cover.

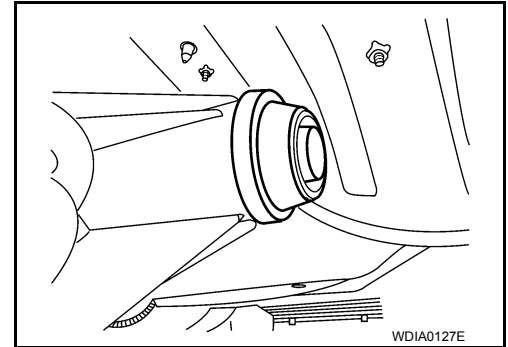

4. Remove the rear oil seal from the rear case using Tool.
CAUTION:
Do not damage the rear case.

Tool number : ST33290001 (J-34286)

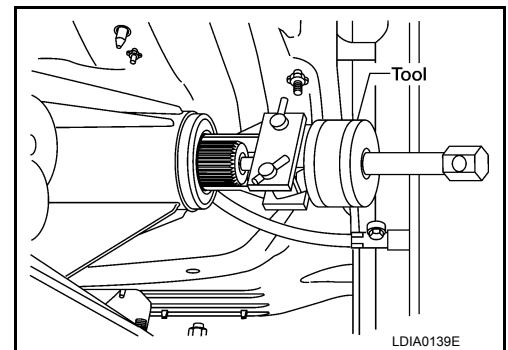

INSTALLATION

1. Install the new rear oil seal until it is flush with the end face of the rear case using Tool.

Tool number : KV38100500 (—)

CAUTION:

- Do not reuse oil seal.
- Apply petroleum jelly to oil seal.

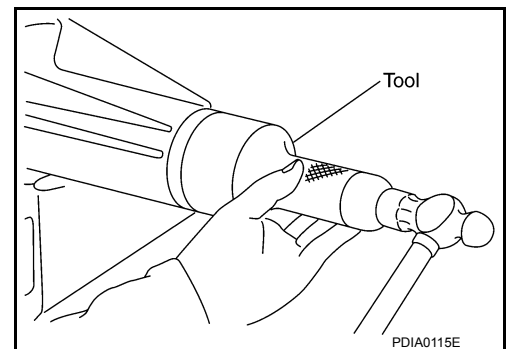

2. Install the oil cover until it reaches the end face of the new dust cover.

CAUTION:

- Position the oil cover with the notch at bottom position.
- Do not reuse duct cover.

REAR OIL SEAL

< REMOVAL AND INSTALLATION >

[TRANSFER: TX15B]

3. Apply petroleum jelly to the circumference of the new dust cover. Position the new dust cover as shown.

CAUTION:

- Do not reuse dust cover.
- Position the protrusions at the position shown.
- (1): Dust cover
- (A): Protrusions
- (2): Rear case assembly

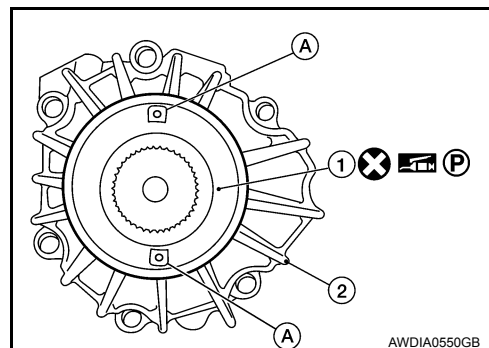

4. Install the new dust cover to the rear case using Tool.

Tool number : KV40105310 (—)

CAUTION:

- Do not reuse dust cover.
- Apply petroleum jelly to dust cover.

5. Install the rear propeller shaft. Refer to [DLN-146, "Removal and Installation"](#) (2S1330) or [DLN-177, "Removal and Installation"](#) (3S1330-2BJ100).
6. Check the transfer fluid level and refill as necessary. Refer to [DLN-93, "Inspection"](#).

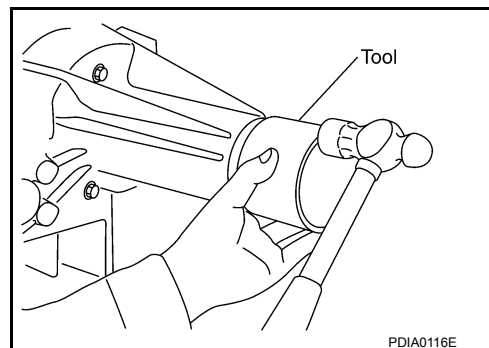

A
B
C
DLN
E
F
G
H
I
J
K
L
M
N
O
P

TRANSFER CONTROL DEVICE

< REMOVAL AND INSTALLATION >

[TRANSFER: TX15B]

TRANSFER CONTROL DEVICE

Removal and Installation

INFOID:000000007323935

REMOVAL

1. Switch the 4WD shift switch to 2WD and set the transfer assembly to 2WD.
2. Disconnect the transfer control device connector.
3. Remove the breather hose from the transfer control device.
4. Remove the bolts and detach the transfer control device.

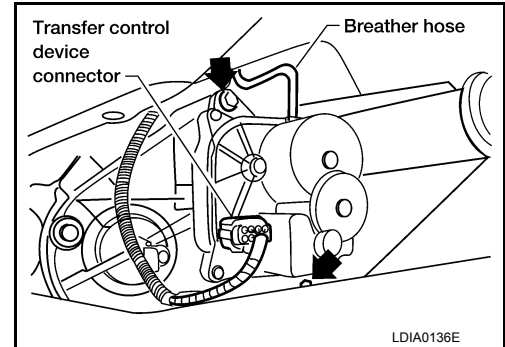

INSTALLATION

1. Install the new O-ring to the transfer control device.

CAUTION:

- Do not reuse O-ring.
- Apply petroleum jelly to O-ring.

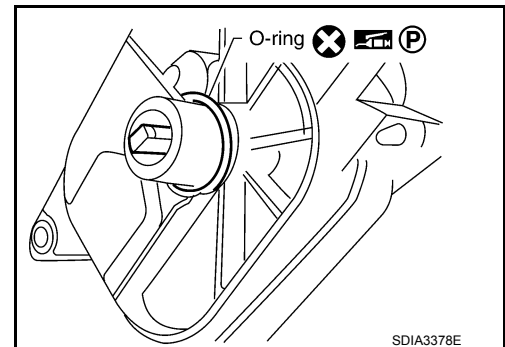

2. Install the transfer control device.
 - a. Turn the control shift rod fully counterclockwise using a flat-bladed screwdriver, and then put a mark on the control shift rod.

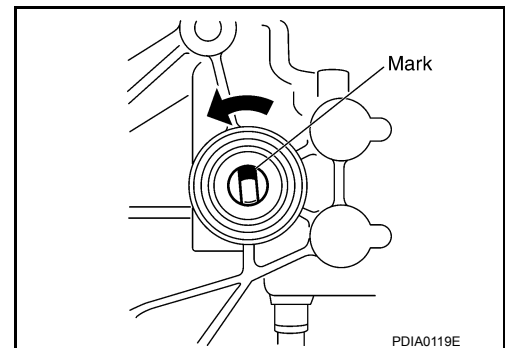

- b. Align the transfer control device shaft cutout with the mark on the control shift rod, and install.

NOTE:

Turn the transfer control device when the transfer control device connection does not match.

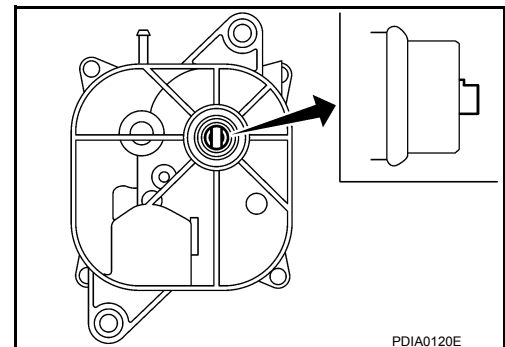

TRANSFER CONTROL DEVICE

< REMOVAL AND INSTALLATION >

[TRANSFER: TX15B]

- c. Tighten the bolts to the specified torque. Refer to [DLN-106. "Exploded View"](#).
3. Install the breather hose to the transfer control device.
4. Connect the transfer control device connector.
5. After the installation, check the 4WD shift indicator pattern. If NG, adjust the position between the transfer assembly and transfer control unit. Refer to [DLN-86. "Precaution for Transfer Assembly and Transfer Control Unit Replacement"](#).

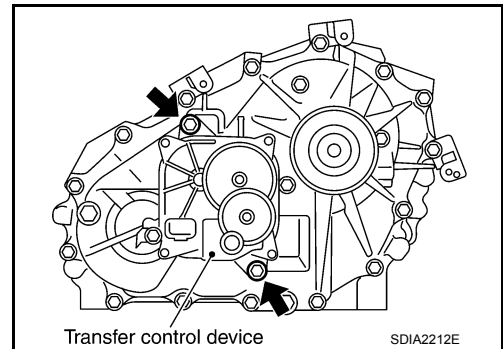

A

B

C

DLN

E

F

G

H

I

J

K

L

M

N

O

P

AIR BREATHER HOSE

< REMOVAL AND INSTALLATION >

[TRANSFER: TX15B]

2. Install transfer control device air breather hose and transfer air breather hose on clip A and clip B with the paint mark facing upward.

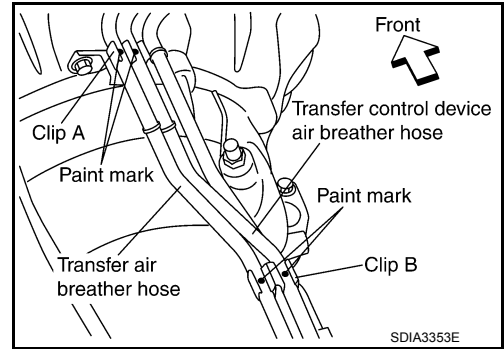

3. Install clip C on transfer control device air breather hose and transfer air breather hose with the paint mark matched.

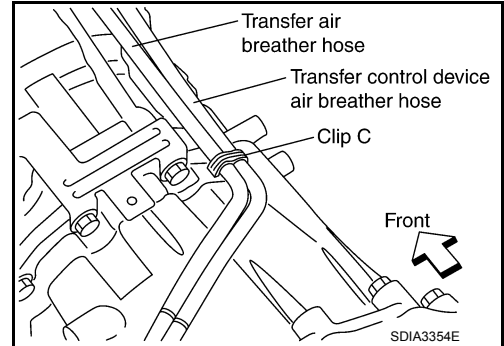

4. Install transfer control device air breather hose and transfer air breather hose on clip D with the paint mark facing upward.

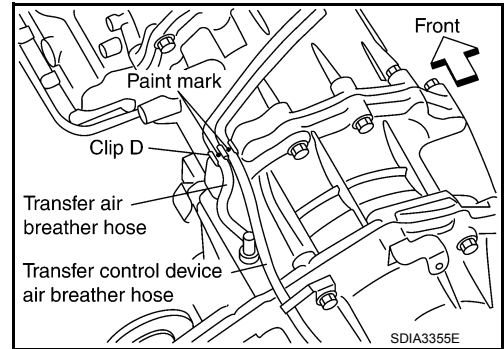

5. Install transfer air breather hose (A) into the breather tube (transfer, metal connector) until the hose end reaches the base of the tube. Set transfer air breather hose with paint mark (B) facing upward.

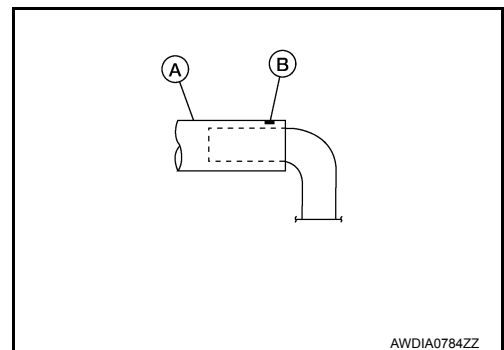

6. Install transfer control device air breather hose into transfer control device (case connector) until the hose end reaches the base of the tube. Set transfer control device air breather hose with paint mark facing forward.

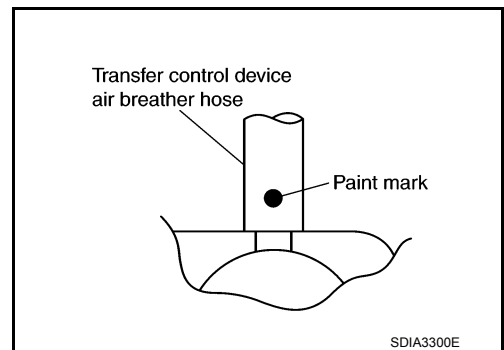

A
B
C
DLN
E
F
G
H
I
J
K
L
M
N
O
P

UNIT REMOVAL AND INSTALLATION

TRANSFER ASSEMBLY

Removal and Installation

INFOID:000000007323937

NOTE:

When removing components such as hoses, tubes/lines, etc., cap or plug openings to prevent fluid from spilling.

REMOVAL

1. Switch 4WD shift switch to 2WD and set transfer assembly to 2WD.
2. Partially drain the transfer fluid. Refer to [DLN-93, "Replacement"](#).
3. Remove the transmission under cover (if equipped) using power tool.
4. Remove the center exhaust tube and main muffler. Refer to [EX-6, "Removal and Installation"](#).
5. Remove the front and rear propeller shafts. Refer to [DLN-137, "Removal and Installation"](#) (front) and [DLN-146, "Removal and Installation"](#) (2S1330) or [DLN-177, "Removal and Installation"](#) (3S1330-2BJ100).

CAUTION:

Do not damage spline, sleeve yoke and rear oil seal when removing rear propeller shaft.

6. Remove insulator nuts from the transmission crossmember. Refer to [TM-74, "Removal and Installation from Vehicle \(For 4WD Models\)"](#) (M/T) or [TM-307, "Removal and Installation for VQ40DE 4WD Models"](#) (A/T).
7. Position two suitable jacks under the transmission and transfer assembly.
8. Remove the transmission crossmember. Refer to [TM-74, "Removal and Installation from Vehicle \(For 4WD Models\)"](#) (M/T) or [TM-307, "Removal and Installation for VQ40DE 4WD Models"](#) (A/T).

WARNING:

Support transmission and transfer assembly using two suitable jacks while removing transmission crossmember.

9. Disconnect the electrical connectors from the following:
 - ATP switch
 - 4LO switch
 - Wait detection switch
 - Transfer control device
10. Remove wire harness from retainers.
11. Disconnect each air breather hose from the following. Refer to [DLN-102, "Removal and Installation"](#).
 - Transfer control device
 - Breather tube (transfer)
12. Remove the transfer to transmission and transmission to transfer bolts.

WARNING:

Support transfer assembly with suitable jack while removing it.

13. Remove the transfer assembly.

CAUTION:

Do not damage transmission rear oil seal (A/T).

INSTALLATION

Installation is in the reverse order of removal.

- Tighten the bolts to specification.

Tightening torque : 36 N·m (3.7kg-m, 27 ft-lb)

- Fill the transfer with new fluid. Refer to [DLN-93, "Replacement"](#).
- Check the transfer fluid. Refer to [MA-49, "TRANSFER FLUID : Inspection"](#).
- Start the engine for one minute. Then stop the engine and recheck the transfer fluid. Refer to [MA-49, "TRANSFER FLUID : Inspection"](#).

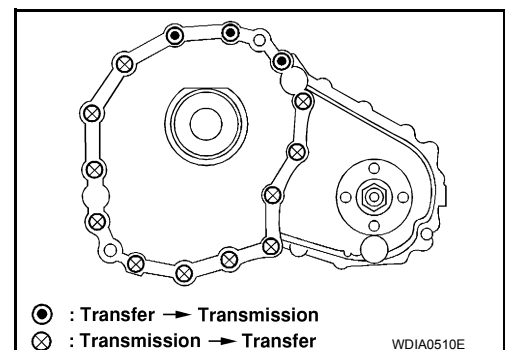

TRANSFER ASSEMBLY

< UNIT REMOVAL AND INSTALLATION >

[TRANSFER: TX15B]

- After the installation, check the 4WD shift indicator pattern. If NG, adjust the position between the transfer assembly and transfer control unit. Refer to [DLN-86, "Precaution for Transfer Assembly and Transfer Control Unit Replacement"](#).

A

B

C

DLN

E

F

G

H

I

J

K

L

M

N

O

P

TRANSFER ASSEMBLY

< UNIT DISASSEMBLY AND ASSEMBLY >

[TRANSFER: TX15B]

UNIT DISASSEMBLY AND ASSEMBLY

TRANSFER ASSEMBLY

Exploded View

INFOID:000000007323938

COMPONENTS

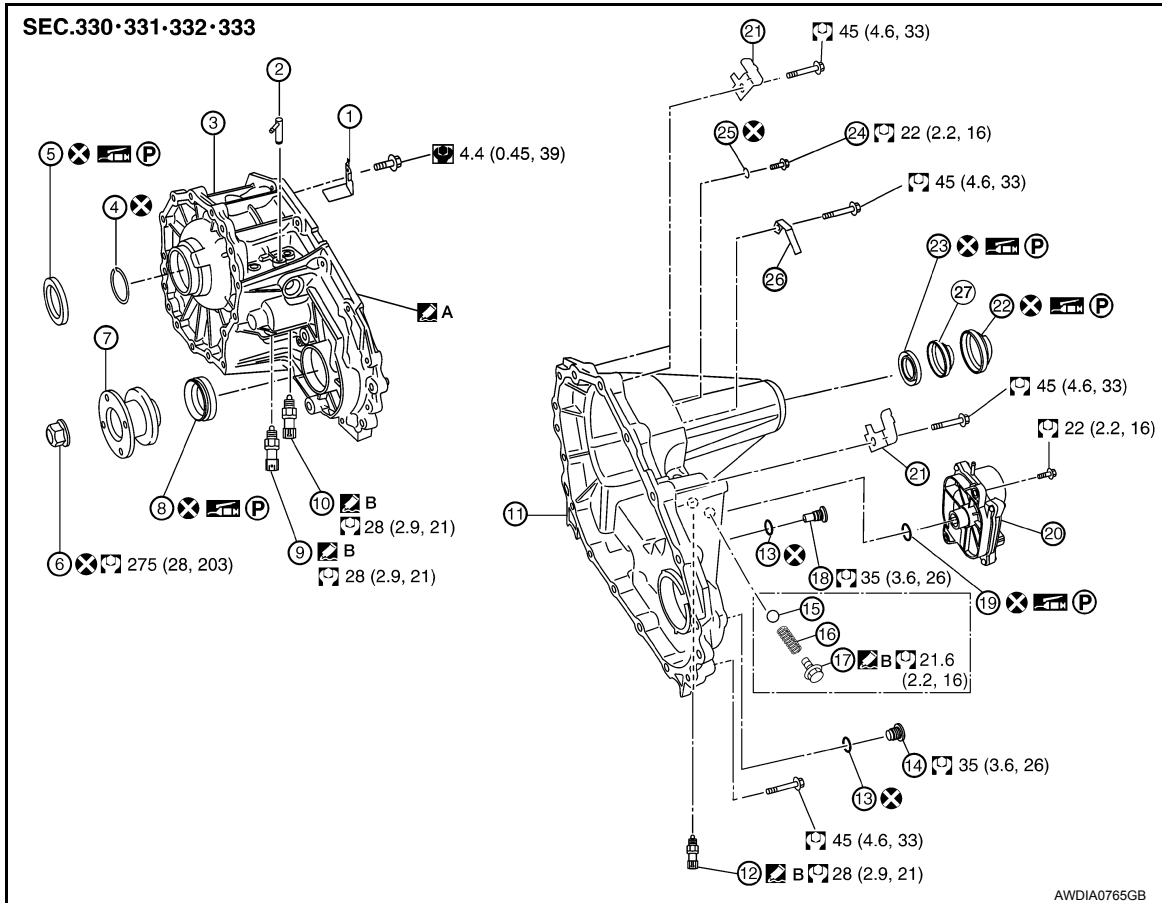

- | | | |
|---|--|---------------------------------------|
| 1. Baffle plate | 2. Breather tube | 3. Front case |
| 4. Snap ring | 5. Input oil seal | 6. Self-lock nut |
| 7. Companion flange | 8. Front oil seal | 9. 4LO switch (gray with green paint) |
| 10. ATP switch (black) | 11. Rear case | 12. Wait detection switch (gray) |
| 13. Gasket | 14. Filler plug | 15. Check ball (M/T models only) |
| 16. Check shift spring (M/T models only) | 17. Check plug (M/T models only) | 18. Drain plug |
| 19. O-ring | 20. Transfer control device | 21. Harness bracket |
| 22. Dust cover | 23. Rear oil seal | 24. Retainer bolt |
| 25. Gasket | 26. Air breather hose clamp | 27. Oil cover |
| A. Apply Genuine Anaerobic Liquid Gasket or equivalent. | B. Apply Genuine Silicone RTV or equivalent. | |

TRANSFER ASSEMBLY

< UNIT DISASSEMBLY AND ASSEMBLY >

[TRANSFER: TX15B]

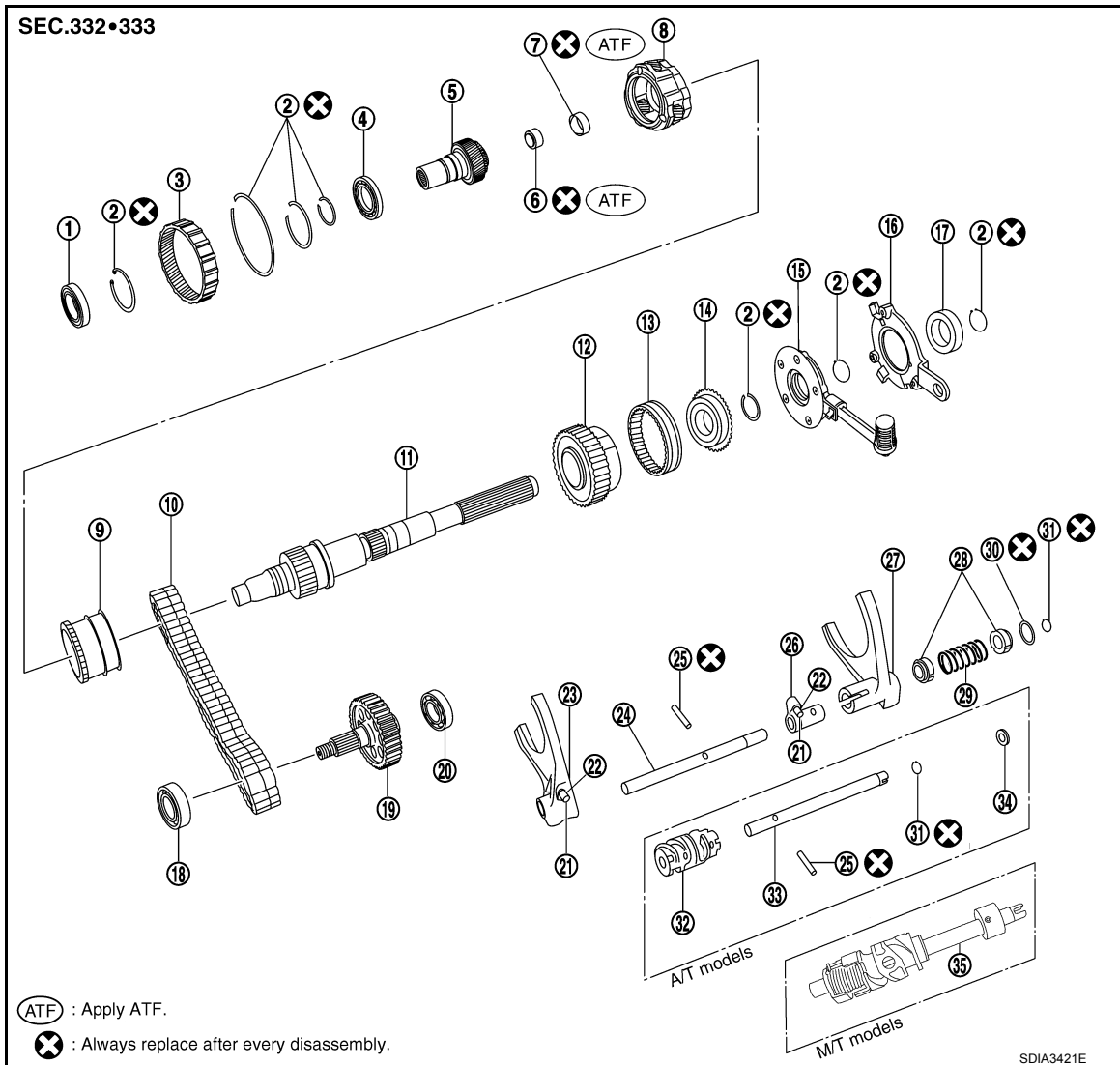

- | | | |
|-----------------------|--------------------------------|-----------------------|
| 1. Input bearing | 2. Snap ring | 3. Internal gear |
| 4. Carrier bearing | 5. Sun gear | 6. Needle bearing |
| 7. Metal bushing | 8. Planetary carrier assembly | 9. L-H sleeve |
| 10. Drive chain | 11. Mainshaft | 12. Sprocket |
| 13. 2-4 sleeve | 14. Clutch gear | 15. Oil pump assembly |
| 16. Retainer | 17. Mainshaft rear bearing | 18. Front bearing |
| 19. Front drive shaft | 20. Rear bearing | 21. Clevis pin |
| 22. Shift collar | 23. L-H shift fork | 24. L-H shift rod |
| 25. Retaining pin | 26. 2-4 shift bracket | 27. 2-4 shift fork |
| 28. Fork guide collar | 29. 2-4 shift fork spring | 30. Retaining ring |
| 31. Snap ring | 32. Drum cam | 33. Control shift rod |
| 34. Spacer | 35. Control shift rod assembly | |

Disassembly and Assembly

INFOID:000000007323939

DISASSEMBLY

1. Remove the drain plug and filler plug.

A
B
C
DLN
E
F
G
H
I
J
K
L
M
N
O
P

TRANSFER ASSEMBLY

< UNIT DISASSEMBLY AND ASSEMBLY >

[TRANSFER: TX15B]

2. Remove the transfer control device from the rear case.
3. Remove the O-ring from the transfer control device.

CAUTION:
Do not reuse O-ring.

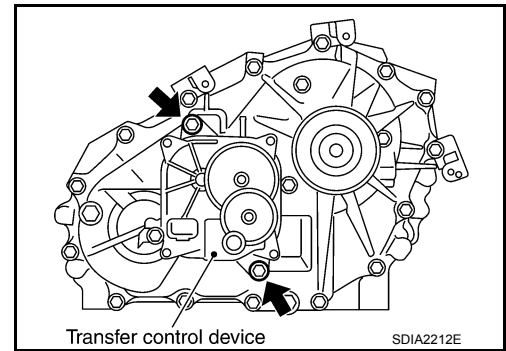

4. Remove the self-lock nut from the companion flange, using suitable tool.

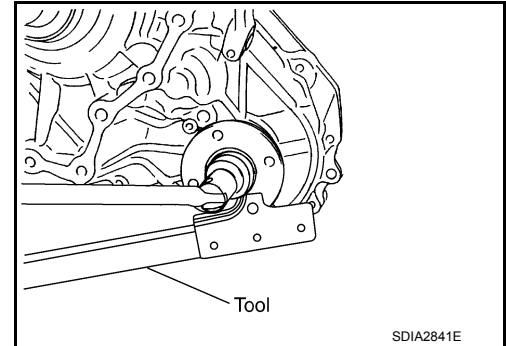

5. Put a matching mark on top of the front drive shaft in line with the mark on the companion flange.

CAUTION:
Use paint to make the matching mark on the front drive shaft. Do not damage the front drive shaft.

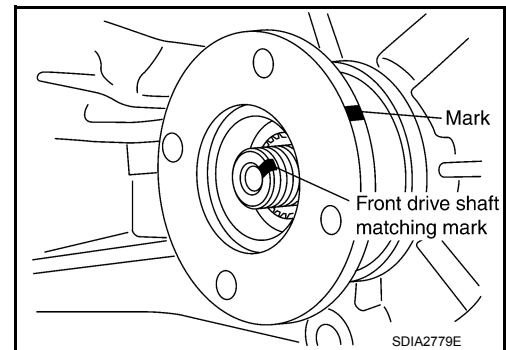

6. Remove the companion flange, using suitable tool.

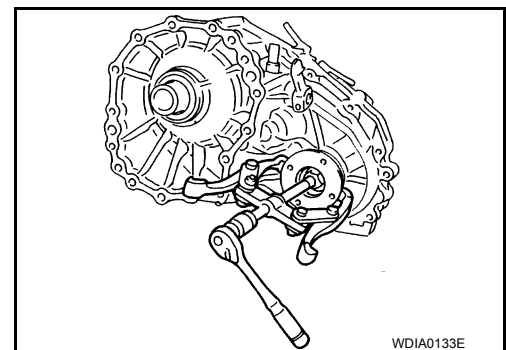

7. Remove the front oil seal from the front case, using Tool.

Tool number : ST33290001 (J-34286)

CAUTION:
Do not damage front case or front drive shaft.

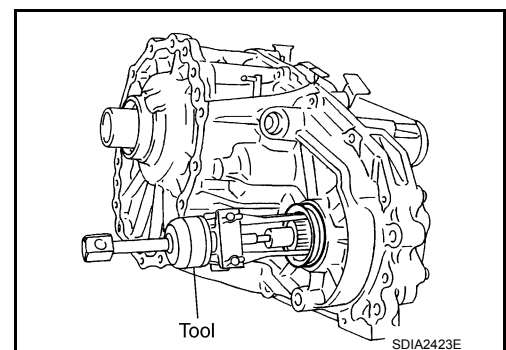

TRANSFER ASSEMBLY

< UNIT DISASSEMBLY AND ASSEMBLY >

[TRANSFER: TX15B]

8. Remove the 4LO switch [gray (with green paint)] and ATP switch (black) from the front case.

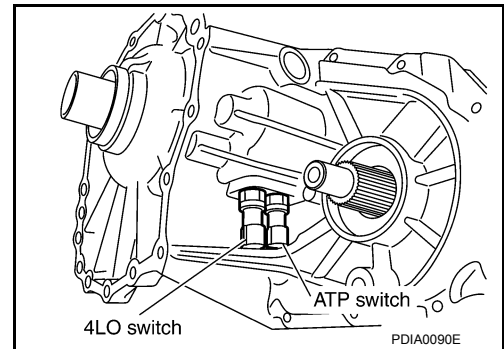

9. Remove the wait detection switch (gray) from the rear case.

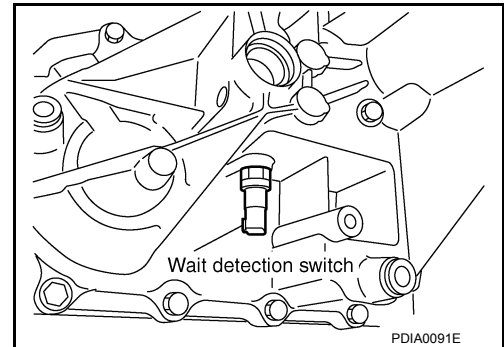

10. Remove check plug, check shift spring and check ball (M/T models only).

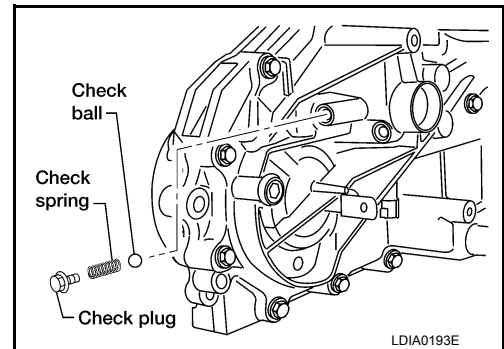

11. Remove the dust cover from the rear case, using suitable tool.

CAUTION:
Do not damage rear case.

12. Remove oil cover from the dust cover.

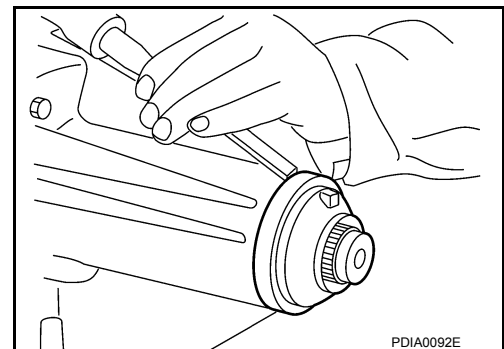

13. Remove the rear oil seal from the rear case, using Tool.

CAUTION:
Do not damage rear case or mainshaft.

Tool number : ST33290001 (J-34286)

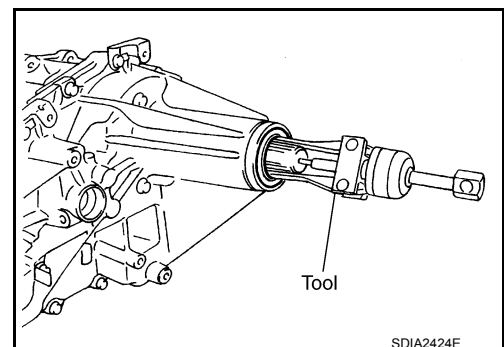

A
B
C
DLN
E
F
G
H
I
J
K
L
M
N
O
P

TRANSFER ASSEMBLY

< UNIT DISASSEMBLY AND ASSEMBLY >

[TRANSFER: TX15B]

14. Remove the input oil seal from the front case, using suitable tool.

CAUTION:

Do not damage front case, sun gear or input bearing.

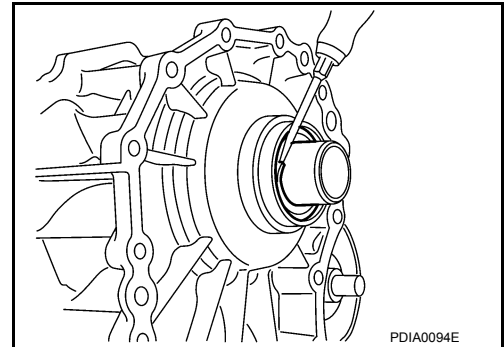

15. Remove the retainer bolts and gaskets.

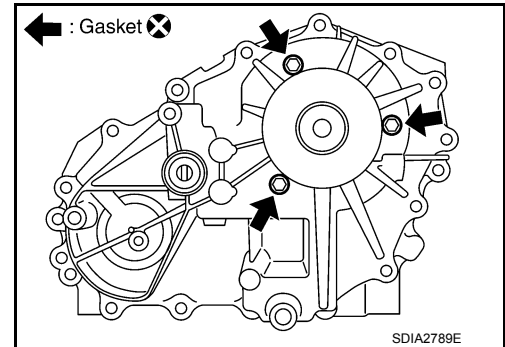

16. Remove the rear case bolts, harness bracket and air breather hose clamp from the rear case.

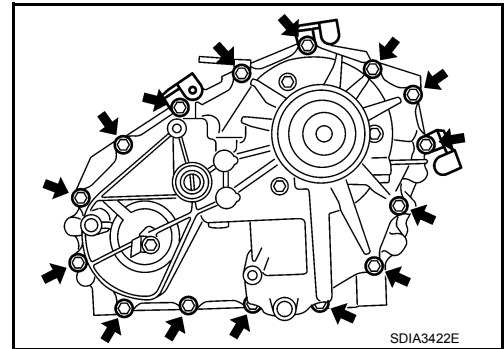

17. Separate the front case from the rear case. Then remove the rear case by prying it up, using suitable tool.

CAUTION:

Do not damage the mating surface.

18. Remove the spacer from the control shift rod (A/T models only).

CAUTION:

Do not drop spacer.

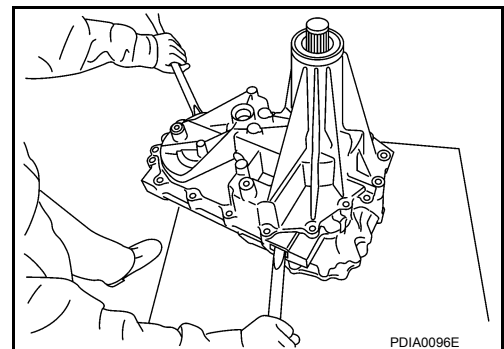

19. Remove the snap ring from the mainshaft, using suitable tool.

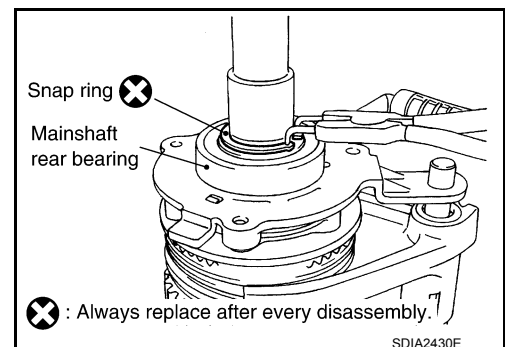

TRANSFER ASSEMBLY

< UNIT DISASSEMBLY AND ASSEMBLY >

[TRANSFER: TX15B]

20. Remove the mainshaft rear bearing from the mainshaft, using suitable tool.
21. Remove the retainer from the mainshaft.

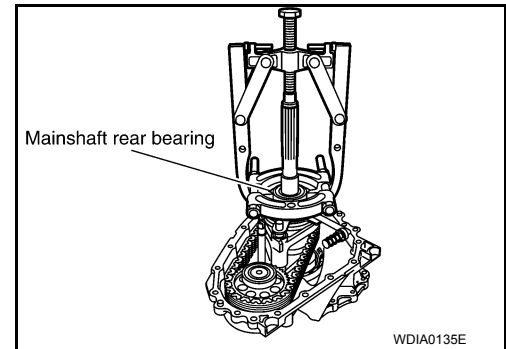

22. Remove the snap ring from the mainshaft, using suitable tool.
23. Remove the oil pump assembly from the mainshaft.

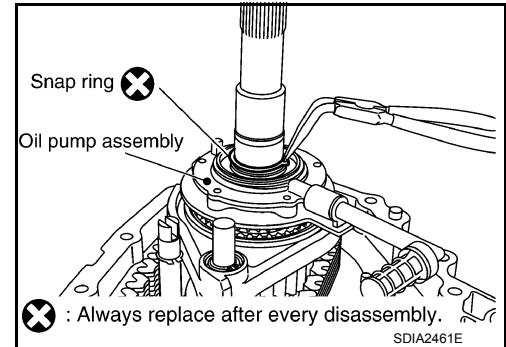

24. Remove the snap ring from the mainshaft, using suitable tool.
25. Remove the clutch gear from the mainshaft.

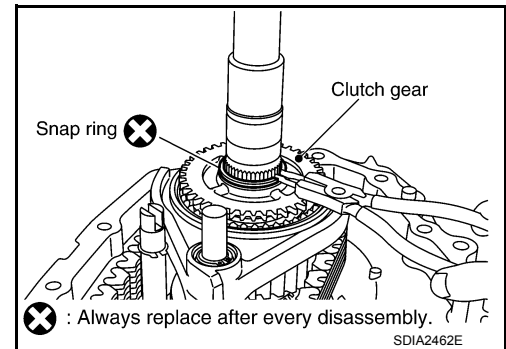

26. Remove the snap ring from the L-H shift rod assembly, using suitable tool.
27. Remove the 2-4 sleeve and 2-4 shift fork assembly from the mainshaft.

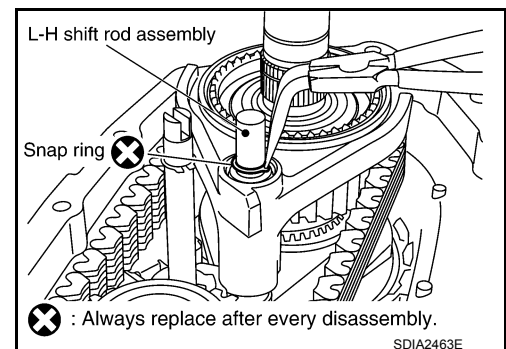

28. Remove the drive chain together with the sprocket and front drive shaft from the front case.
29. Remove the mainshaft from the sun gear assembly.
30. Remove the L-H shift rod assembly and control shift rod assembly from the front case.
31. Remove the L-H sleeve together with the L-H shift fork from the planetary carrier assembly.

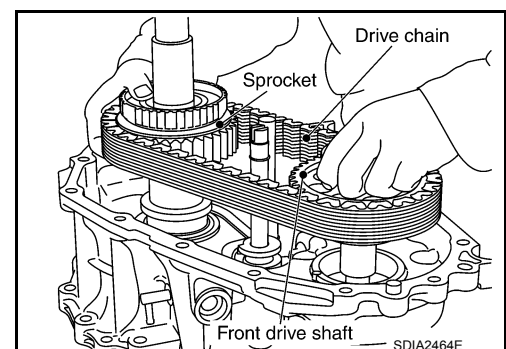

A
B
C
DLN
E
F
G
H
I
J
K
L
M
N
O
P

TRANSFER ASSEMBLY

< UNIT DISASSEMBLY AND ASSEMBLY >

[TRANSFER: TX15B]

32. Remove the snap ring from the sun gear.

CAUTION:

Do not damage sun gear or input bearing.

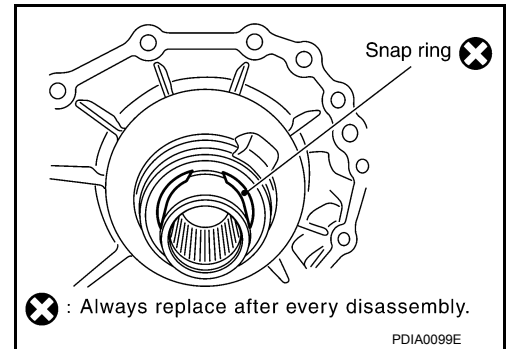

33. Press the sun gear assembly and planetary carrier assembly from the front case, using Tool.

Tool number : KV38100200 (—)

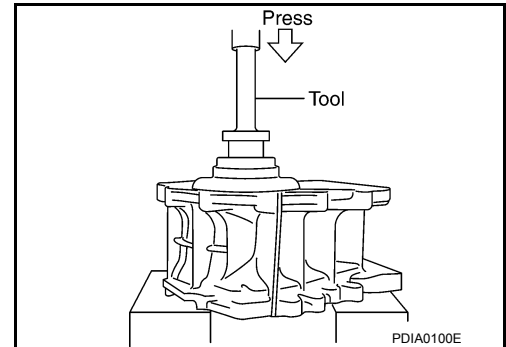

34. Remove the snap ring from the front case.

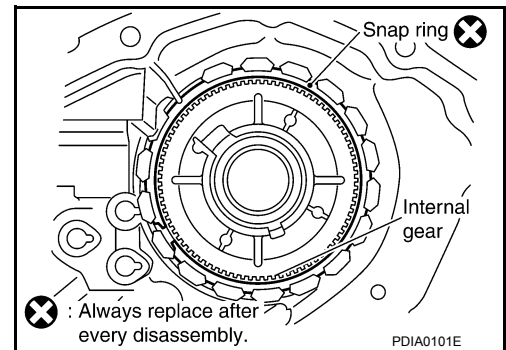

35. Remove the internal gear from the front case.

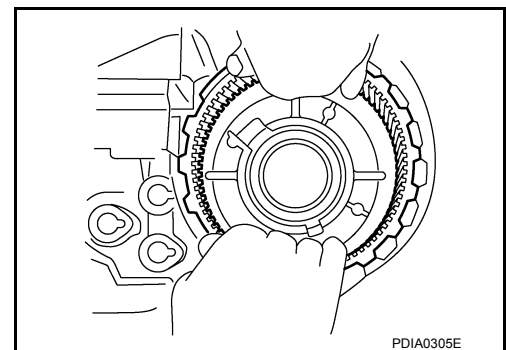

36. Remove the snap ring from the front case.

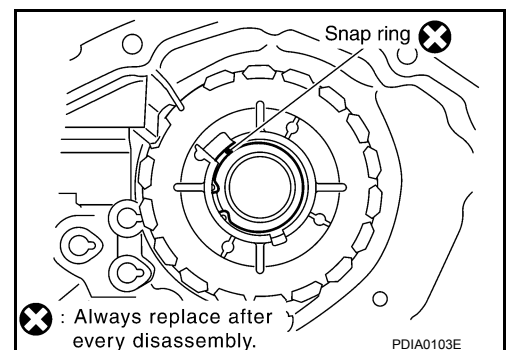

TRANSFER ASSEMBLY

< UNIT DISASSEMBLY AND ASSEMBLY >

[TRANSFER: TX15B]

37. Remove the input bearing from the front case, using Tool.

Tool number : KV38100200 (—)

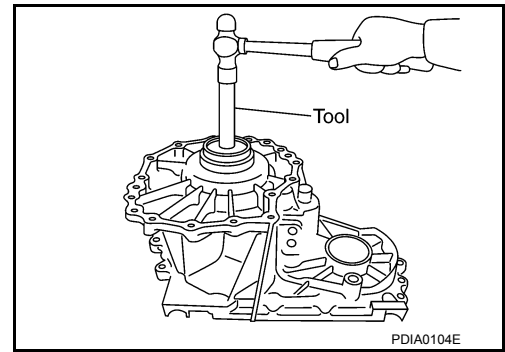

38. Remove the baffle plate from the front case.

39. Remove the breather tube from the front case.

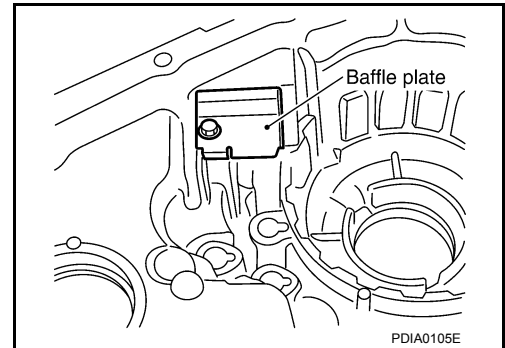

INSPECTION AFTER DISASSEMBLY

Case

Check the contact surfaces of the shift rod and bearing for wear and damage. If any is found, replace with a new one.

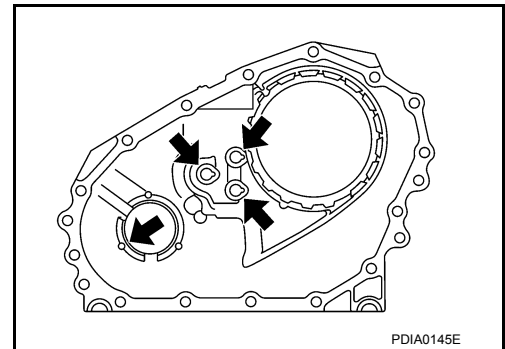

Sleeve

Check the items below. If necessary, replace them with new ones.

- Damage and excessive wear of the contact surfaces of the sprocket, mainshaft and sleeve.
- Sleeve must move smoothly.

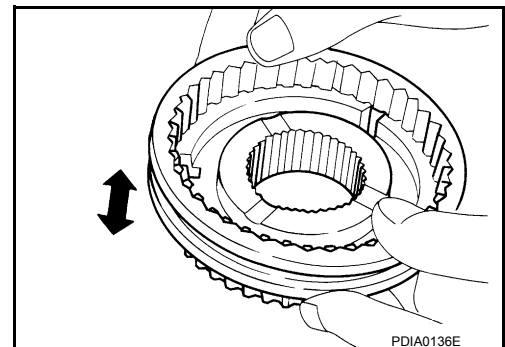

Gear, Shaft and Drive Chain

A
B
C
DLN
E
F
G
H
I
J
K
L
M
N
O
P

TRANSFER ASSEMBLY

< UNIT DISASSEMBLY AND ASSEMBLY >

[TRANSFER: TX15B]

Check the items below. If necessary, replace them with new ones.

- Damage, peeling, uneven wear and bending of the shaft.
- Excessive wear, damage and peeling of the gear.

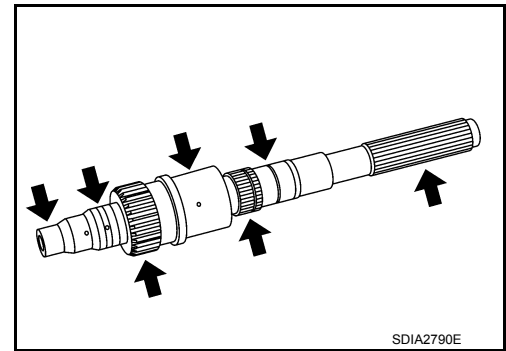

Bearing

Check the bearing for damage and rough rotation. If necessary, replace it with a new one.

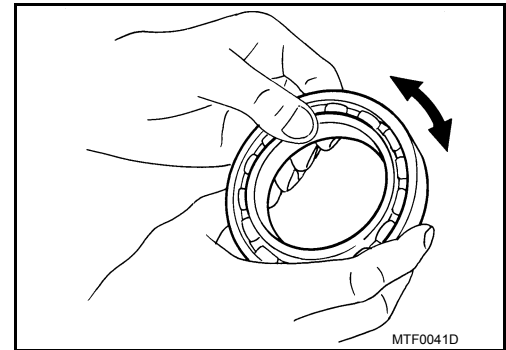

ASSEMBLY

1. Install the breather tube.

CAUTION:

Install breather tube in the direction shown.

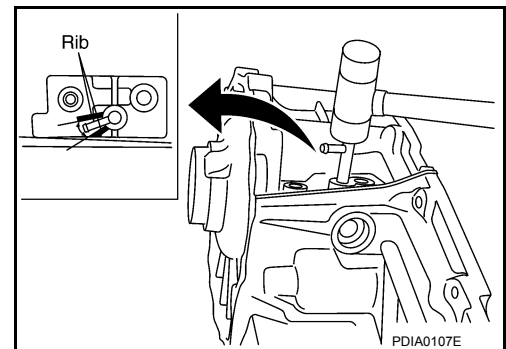

2. Install the baffle plate to the front case. Tighten the bolt to the specified torque. Refer to [DLN-107, "Disassembly and Assembly"](#).

CAUTION:

Install baffle plate by pushing it in the direction shown while tightening the bolt.

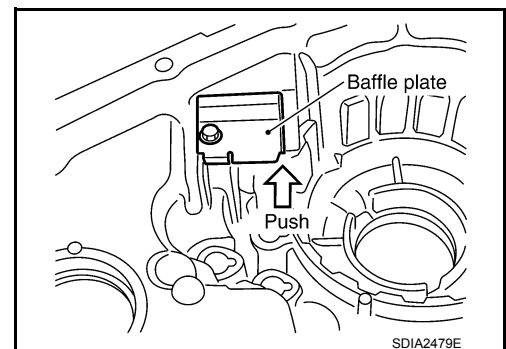

TRANSFER ASSEMBLY

< UNIT DISASSEMBLY AND ASSEMBLY >

[TRANSFER: TX15B]

3. Install the input bearing to the front case, using Tool.

Tool number : ST30720000 (J-25405)

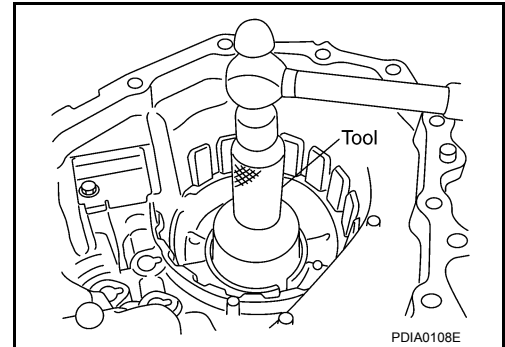

4. Install the new snap ring to the front case.

CAUTION:
Do not reuse snap ring.

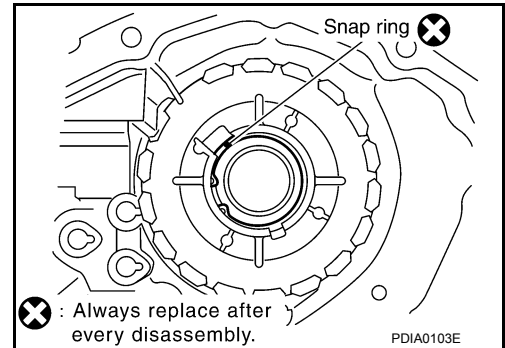

5. Install the internal gear with the groove facing up into the front case.

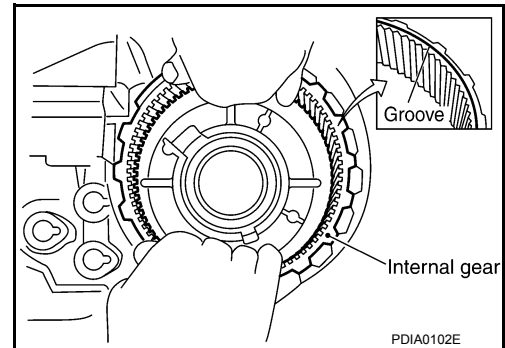

6. Install the snap ring to the front case.

CAUTION:
Do not reuse snap ring.

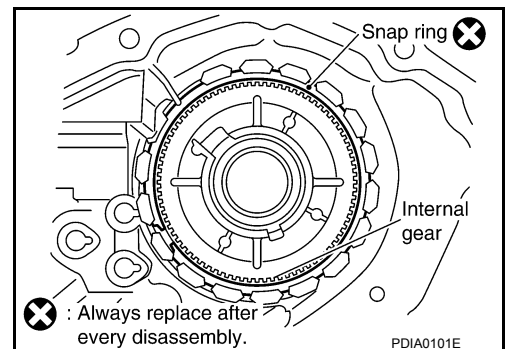

7. Install the planetary carrier assembly and sun gear assembly to the front case, using Tool.

Tool number : KV38100200 (—)

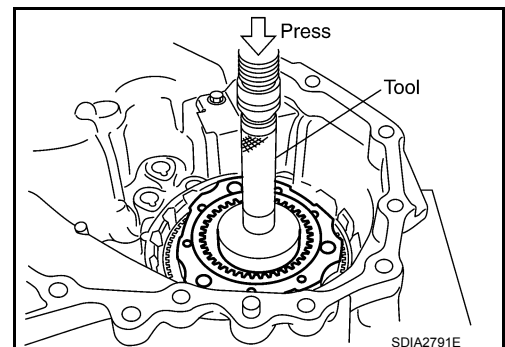

A
B
C
DLN
E
F
G
H
I
J
K
L
M
N
O
P

TRANSFER ASSEMBLY

< UNIT DISASSEMBLY AND ASSEMBLY >

[TRANSFER: TX15B]

8. Install the snap ring to the sun gear.

CAUTION:

- Do not reuse snap ring.
- Do not damage sun gear.

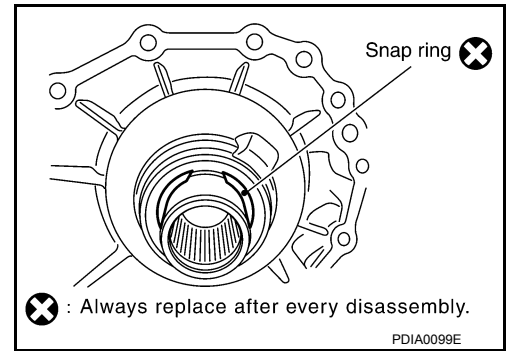

9. Set the L-H sleeve together with the L-H shift fork assembly onto the planetary carrier assembly.

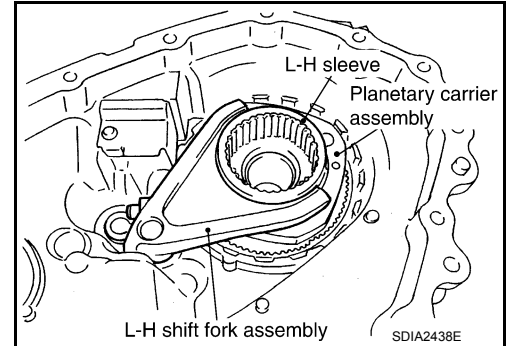

10. Install the control shift rod assembly to the front case.

CAUTION:

Set pin of L-H shift fork assembly into the groove of drum cam.

11. Turn the control shift rod assembly fully counterclockwise.

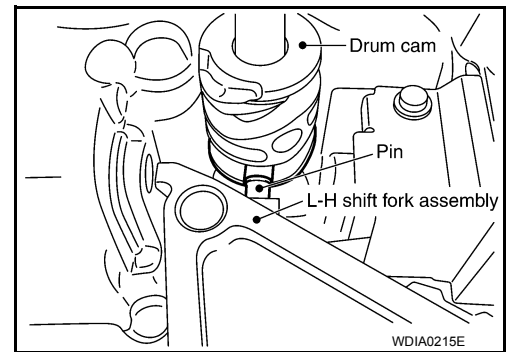

12. Install the L-H shift rod assembly through the L-H shift fork assembly opening to the front case.

CAUTION:

Set pin of L-H shift rod assembly into the groove of drum cam.

13. Install the mainshaft to the sun gear assembly.

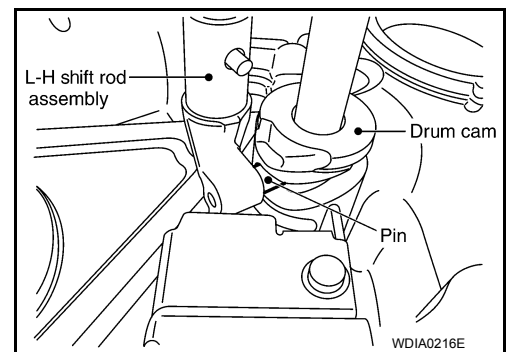

14. Install the drive chain to the front drive shaft and sprocket.

CAUTION:

Install with the Identification mark of drive chain on the side of the rear bearing of front drive shaft.

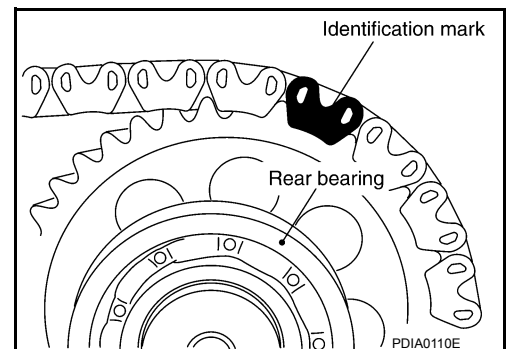

TRANSFER ASSEMBLY

< UNIT DISASSEMBLY AND ASSEMBLY >

[TRANSFER: TX15B]

15. Install the drive chain together with the front drive shaft and sprocket to the front case.

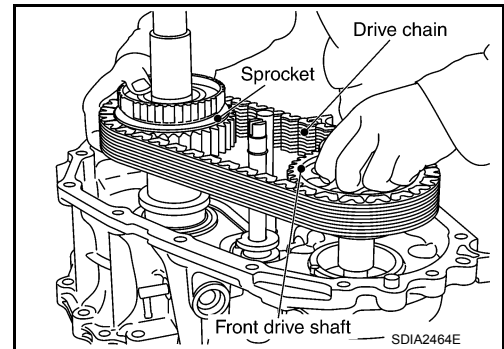

16. Install the 2-4 sleeve and 2-4 shift fork assembly to the mainshaft.

CAUTION:

- Install with proper orientation of 2-4 sleeve.
- Install 2-4 shift fork with engaging the grooves of 2-4 shift fork in the retaining pin of 2-4 shift bracket.

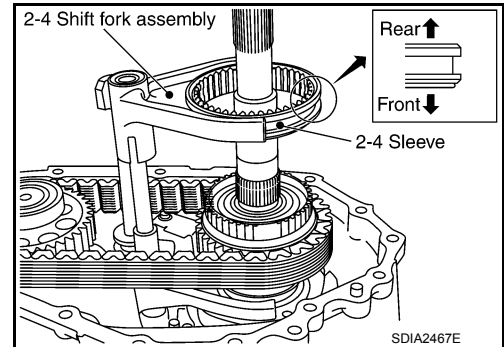

17. Install the snap ring to the L-H shift rod assembly, using suitable tool.

CAUTION:

Do not reuse snap ring.

18. Install the clutch gear to the mainshaft.

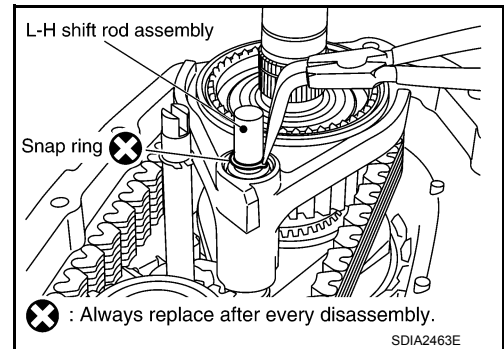

19. Install the snap ring to the mainshaft, using suitable tool.

CAUTION:

Do not reuse snap ring.

20. Install the oil pump assembly to the mainshaft.

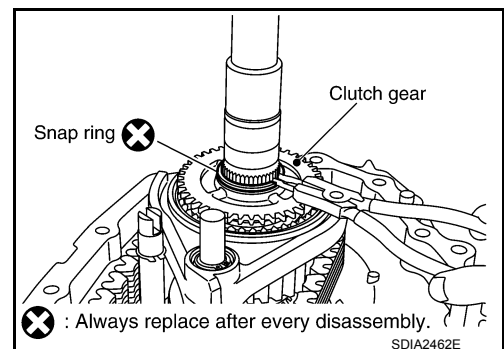

21. Install the snap ring to the mainshaft, using suitable tool.

CAUTION:

Do not reuse snap ring.

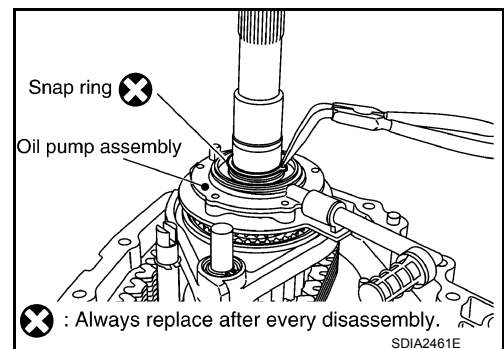

A
B
C
DLN

E
F
G
H
I
J
K

L
M
N
O
P

TRANSFER ASSEMBLY

< UNIT DISASSEMBLY AND ASSEMBLY >

[TRANSFER: TX15B]

22. Install the retainer to the mainshaft.

CAUTION:

Set the projection of oil pump assembly to the identification hole, and then align locating hole of retainer to the L-H shift rod assembly.

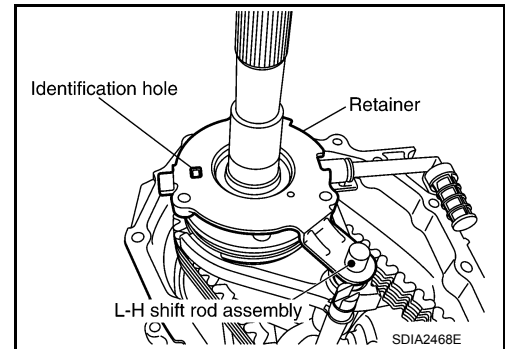

23. Install the mainshaft rear bearing to the mainshaft, using Tool.

Tool number : KV32102700 (—)

CAUTION:

Do not push too hard in order to avoid snap rings becoming dislodged from mainshaft.

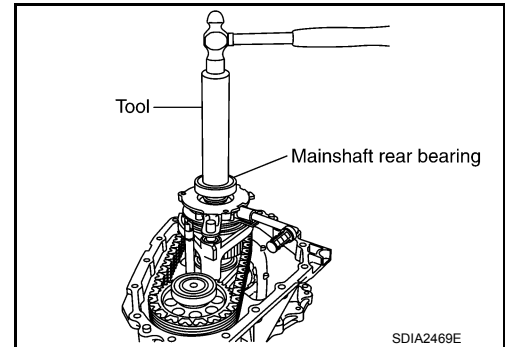

24. Install the snap ring to the mainshaft, using suitable tool.

CAUTION:

Do not reuse snap ring.

25. Install the spacer to the control shift rod (A/T models only).

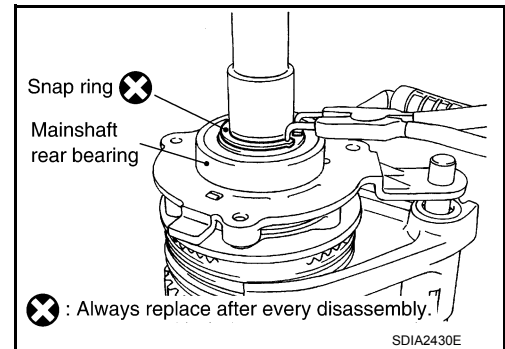

26. Apply liquid gasket to the mating surface of the front case.

• Use **Genuine Anaerobic Liquid Gasket** or equivalent. Refer to [GI-22, "Recommended Chemical Products and Sealants"](#).

CAUTION:

Remove old sealant adhering to mating surfaces. Also remove any moisture, oil, or foreign material adhering to application and mating surfaces.

27. Install the rear case to the front case.

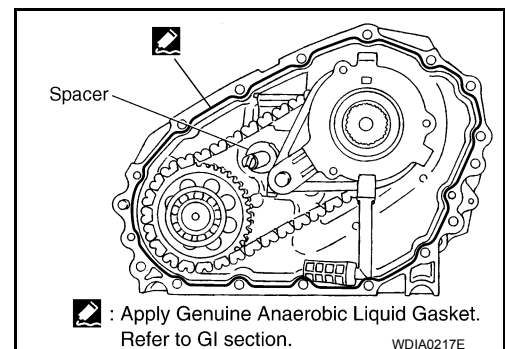

28. Tighten the bolts to the specified torque. Refer to [DLN-106, "Exploded View"](#).

CAUTION:

Be sure to install the harness brackets and air breather hose clamp.

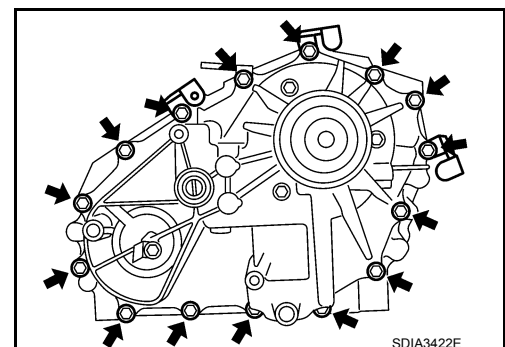

TRANSFER ASSEMBLY

< UNIT DISASSEMBLY AND ASSEMBLY >

[TRANSFER: TX15B]

29. Install the retainer bolts with new gaskets. Tighten the bolts to the specified torque. Refer to [DLN-106, "Exploded View"](#).

CAUTION:

- Do not reuse gasket.
- Tighten them to the specified torque again.

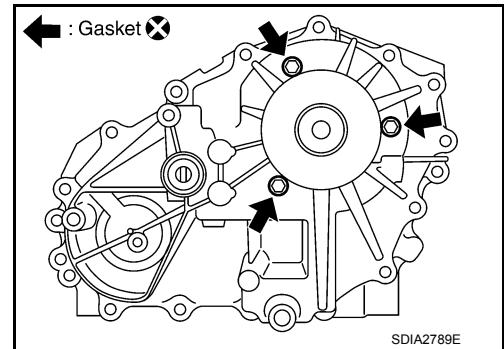

30. Apply petroleum jelly to the circumference of the oil seal, and install it to the front case, using Tools.

Dimension (A) : 4.0 - 4.6 mm (0.157 - 0.181 in)

Tool number (A): ST30720000 (J-25405)
(B): KV40104830 (—)

CAUTION:

- Do not reuse oil seal.
- Apply petroleum jelly to oil seal.

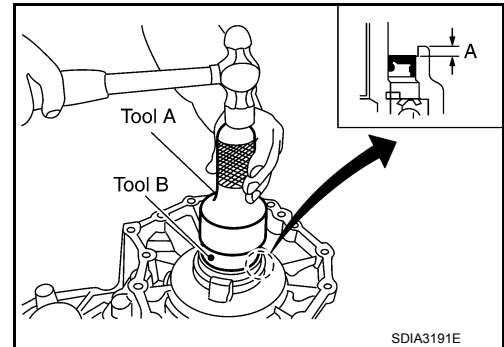

31. Install the rear oil seal until it is flush with the end face of the rear case, using Tool.

Tool number : KV38100500 (—)

CAUTION:

- Do not reuse oil seal.
- Apply petroleum jelly to oil seal.

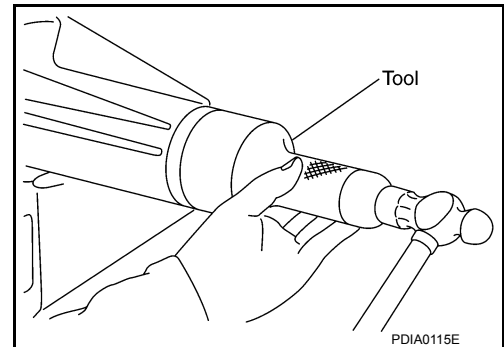

32. Install the oil cover until it reaches the end face of the new dust cover.

CAUTION:

Position the oil cover with the notch at bottom position.

33. Apply petroleum jelly to the circumference of the new dust cover. Position the dust cover as shown.

CAUTION:

- Do not reuse dust cover.
- Position the protrusions at the position shown.
- (1): Dust cover
- (A): Protrusions
- (2): Rear case assembly

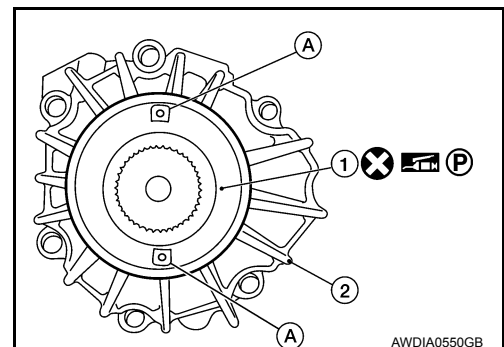

A
B
C
DLN
E
F
G
H
I
J
K
L
M
N
O
P

TRANSFER ASSEMBLY

< UNIT DISASSEMBLY AND ASSEMBLY >

[TRANSFER: TX15B]

34. Install the dust cover to the rear case, using Tool.

Tool number : KV40105310 (—)

CAUTION:

- Do not reuse dust cover.
- Apply petroleum jelly to dust cover.

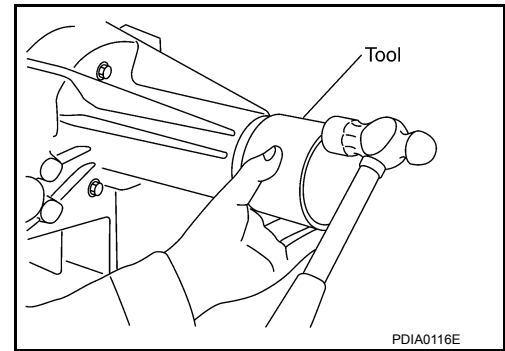

35. Install check ball and check spring to rear case (M/T models only).

36. Apply sealant to thread of check plug, then install it to rear case and tighten to the specified torque (M/T models only). Refer to [DLN-106, "Exploded View"](#).

- Use Genuine Silicone RTV or equivalent. Refer to [GI-22, "Recommended Chemical Products and Sealants"](#).

CAUTION:

Remove old sealant and oil adhering to threads.

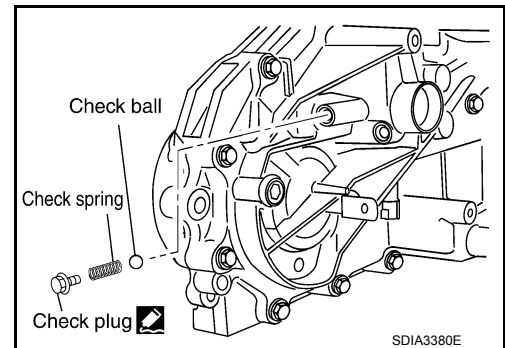

37. Apply sealant to the threads of the wait detection switch (gray). Then install it to the rear case and tighten to the specified torque. Refer to [DLN-106, "Exploded View"](#).

- Use Genuine Silicone RTV or equivalent. Refer to [GI-22, "Recommended Chemical Products and Sealants"](#).

CAUTION:

Remove old sealant and oil adhering to threads.

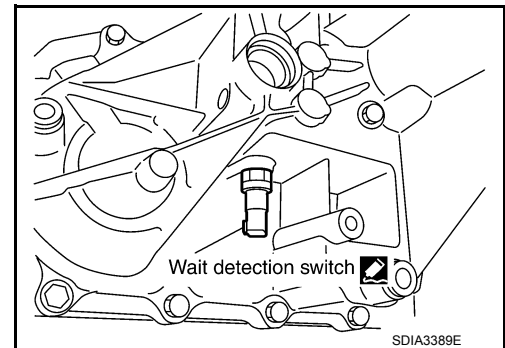

38. Apply sealant to the threads of the 4LO switch (gray with green paint) and ATP switch (black). Then install them to the front case and tighten to the specified torque. Refer to [DLN-106, "Exploded View"](#).

- Use Genuine Silicone RTV or equivalent. Refer to [GI-22, "Recommended Chemical Products and Sealants"](#).

CAUTION:

Remove old sealant and oil adhering to threads.

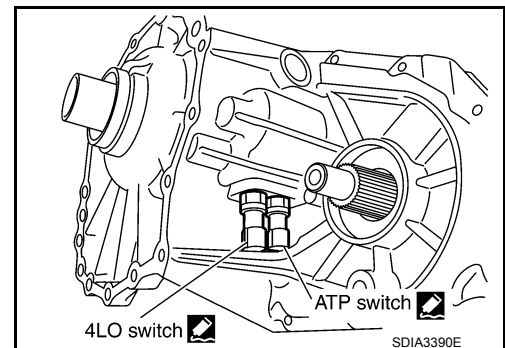

TRANSFER ASSEMBLY

< UNIT DISASSEMBLY AND ASSEMBLY >

[TRANSFER: TX15B]

39. Install the front oil seal until it is flush with the end face of the front case, using Tool.

Tool number : KV38100500 (—)

CAUTION:

- Do not reuse oil seal.
- Apply petroleum jelly to oil seal.

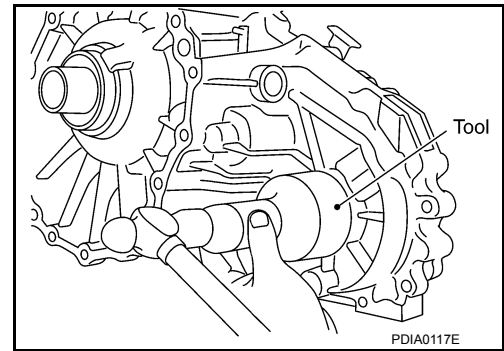

40. Align the matching mark on the front drive shaft with the mark on the companion flange, then install the companion flange.

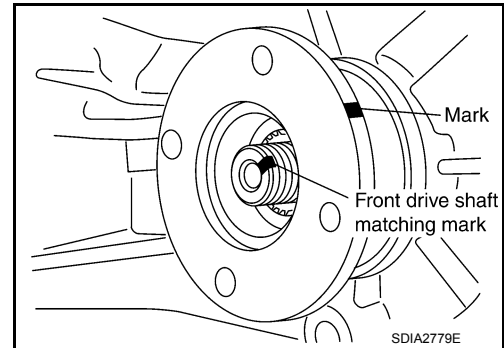

41. Install the companion flange self-lock nut. Tighten to the specified torque, using suitable tool. Refer to [DLN-106, "Exploded View"](#).

CAUTION:

Do not reuse self-lock nut.

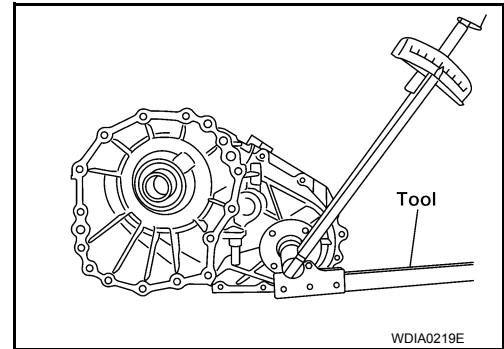

42. Install the O-ring to the transfer control device.

CAUTION:

- Do not reuse O-ring.
- Apply petroleum jelly to O-ring.

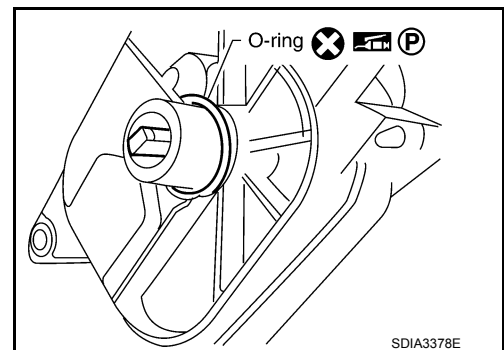

43. Install the transfer control device to the rear case.

- a. Turn the control shift rod fully counterclockwise using a suitable tool, and then put a mark on the control shift rod.

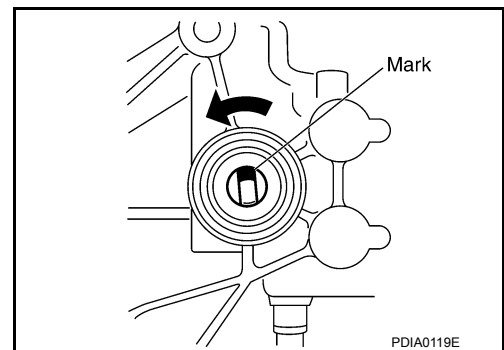

A
B
C
DLN
E
F
G
H
I
J
K
L
M
N
O
P

TRANSFER ASSEMBLY

< UNIT DISASSEMBLY AND ASSEMBLY >

[TRANSFER: TX15B]

- b. Align the transfer control device shaft cutout with the mark on the control shift rod, and install it.

NOTE:

Turn the transfer control device when the transfer control device connection does not match.

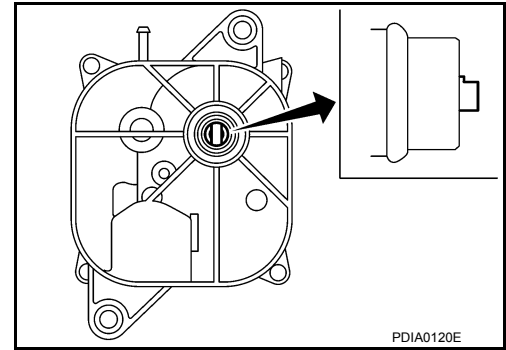

- c. Tighten the bolts to the specified torque. Refer to [DLN-106](#). "[Exploded View](#)".

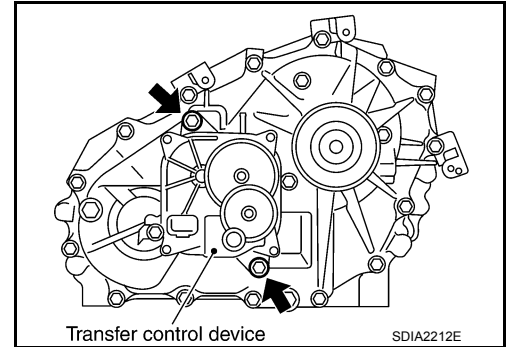

44. Install the drain plug and filler plug with new gaskets to the rear case. Tighten to the specified torque. Refer to [DLN-106](#). "[Exploded View](#)".

CAUTION:

Do not reuse gaskets.

PLANETARY CARRIER

< UNIT DISASSEMBLY AND ASSEMBLY >

[TRANSFER: TX15B]

PLANETARY CARRIER

Disassembly and Assembly

INFOID:000000007323940

DISASSEMBLY

1. Remove the snap ring.
2. Remove the sun gear assembly from the planetary carrier assembly using suitable tool.

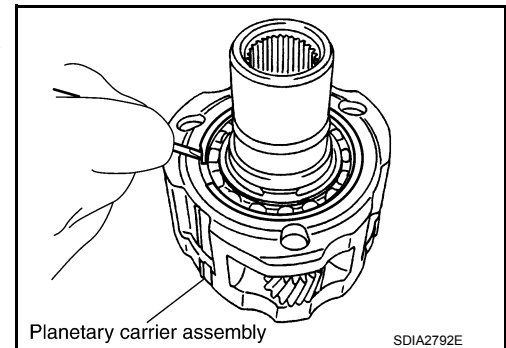

3. Remove the snap ring from the sun gear assembly using suitable tool.

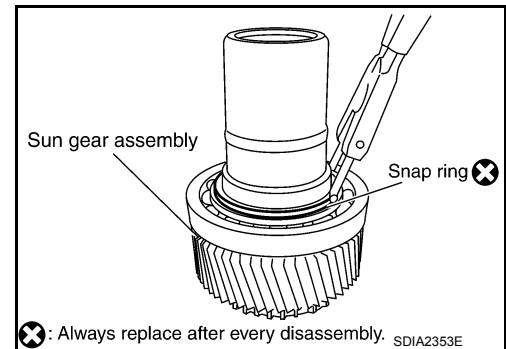

4. Remove the carrier bearing from the sun gear using Tools.

Tool number (A): ST35300000 (—)
(B): ST30021000 (J-22912-01)

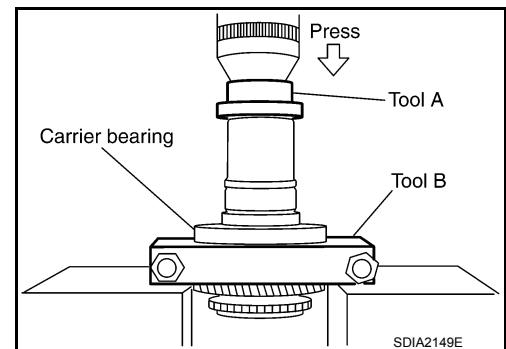

5. Remove the needle bearing from the sun gear using Tool.

Tool number : ST33710000 (—)

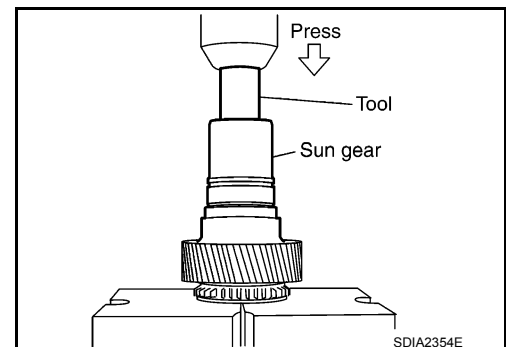

A
B
C
DLN
E
F
G
H
I
J
K
L
M
N
O
P

PLANETARY CARRIER

< UNIT DISASSEMBLY AND ASSEMBLY >

[TRANSFER: TX15B]

6. Remove the metal bushing from the sun gear using Tools.

- Tool number**
- (A): ST33710000 (—)
 - (B): ST35325000 (—)
 - (C): ST33290001 (J-34286)

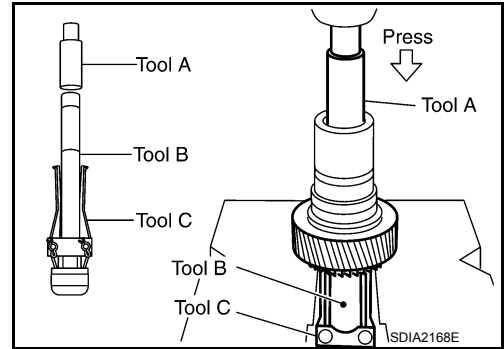

INSPECTION AFTER DISASSEMBLY

Bearing

Check the bearing for damage and rough rotation. If necessary, replace the bearing with a new one.

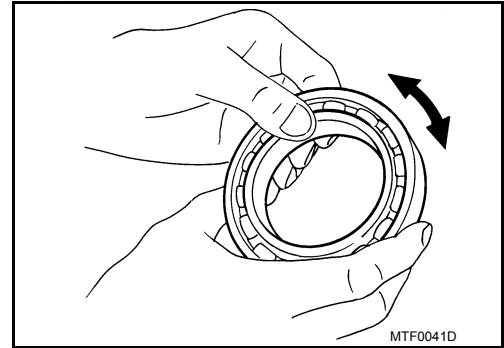

Planetary Carrier

• Measure the end play of each pinion gear. If it is out of specification, replace the planetary carrier assembly with new one.

Pinion gear end play : 0.1 - 0.7 mm (0.004 - 0.028 in)

• Check the working face of each gear and bearing for damage, burrs, partial wear, dents and other abnormality. If any is found, replace the planetary carrier assembly with a new one.

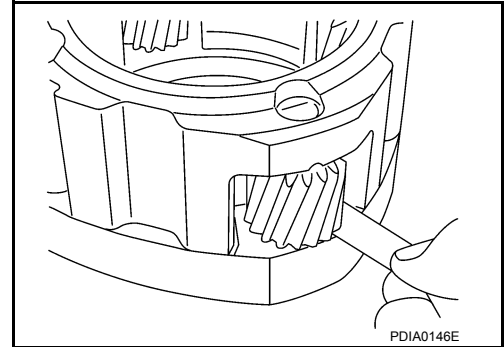

Sun Gear

• Check if the oil passage of the sun gear assembly is clogged. For this, try to pass a 3.6 mm (0.142 in) dia. wire through the oil passage as shown.

• Check the sliding and contact surface of each gear and bearing for damage, burrs, partial wear, dents and other abnormality. If any is found, replace the sun gear assembly with a new one.

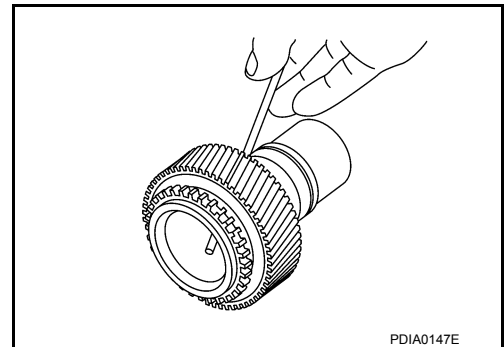

Internal Gear

PLANETARY CARRIER

< UNIT DISASSEMBLY AND ASSEMBLY >

[TRANSFER: TX15B]

Check the internal gear teeth for damage, partial wear, dents or other abnormality. If any is found, replace the internal gear with a new one.

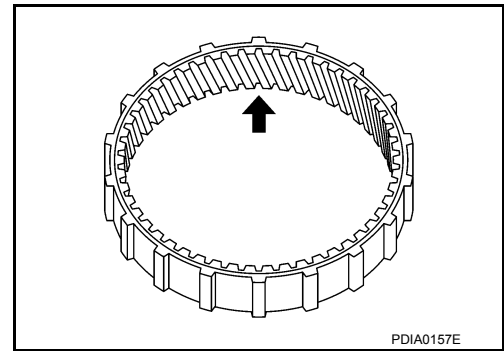

ASSEMBLY

1. Apply ATF to the new metal bushing, then install the new metal bushing until it becomes Dimension (A) using Tool.

Tool number : ST35300000 (—)

Dimension (A) : 7.7 - 8.3mm (0.303 - 0.327in)

CAUTION:

Do not reuse metal bushing.

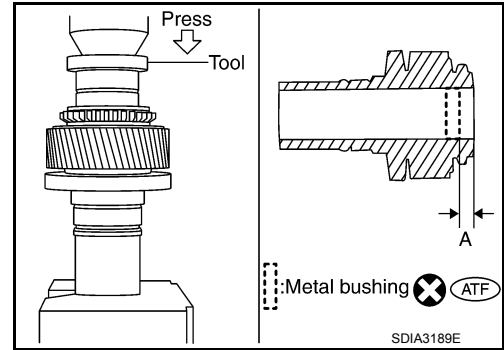

2. Apply ATF to the new needle bearing, then install the new needle bearing until it becomes Dimension (B) using Tool.

Tool number : ST33220000 (—)

Dimension (B) : 62.5 - 63.1mm (2.461 - 2.484in)

CAUTION:

Do not reuse needle bearing.

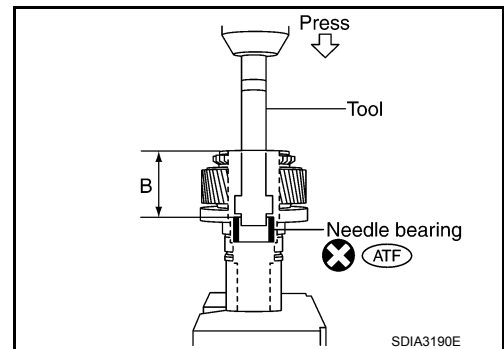

3. Install the carrier bearing to the sun gear using Tools.

Tool number (A): ST30720000 (J-25405)

(B): ST27863000 (—)

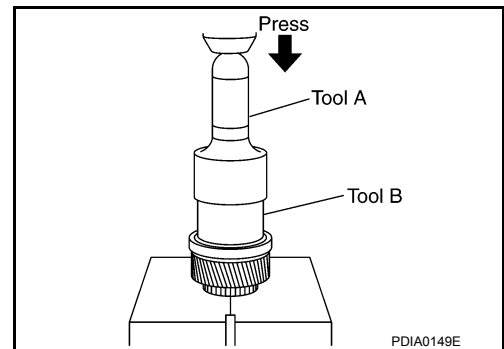

4. Install the new snap ring to the sun gear assembly using suitable tool.

CAUTION:

Do not reuse snap ring.

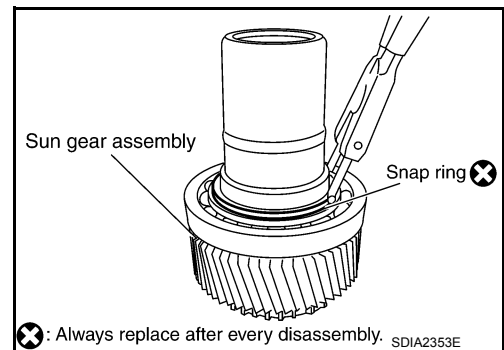

A
B
C
DLN
E
F
G
H
I
J
K
L
M
N
O
P

PLANETARY CARRIER

< UNIT DISASSEMBLY AND ASSEMBLY >

[TRANSFER: TX15B]

5. Install the sun gear assembly to the planetary carrier assembly.
6. Install the new snap ring to the planetary carrier assembly.

CAUTION:

Do not reuse snap ring.

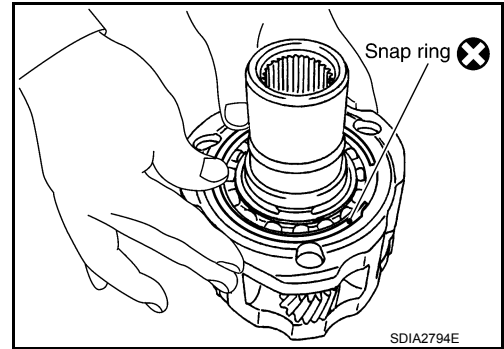

FRONT DRIVE SHAFT

< UNIT DISASSEMBLY AND ASSEMBLY >

[TRANSFER: TX15B]

FRONT DRIVE SHAFT

Disassembly and Assembly

INFOID:000000007323941

DISASSEMBLY

1. Remove the front bearing using Tools.

Tool number (A): ST35300000 (—)
(B): ST30021000 (J-22912-01)

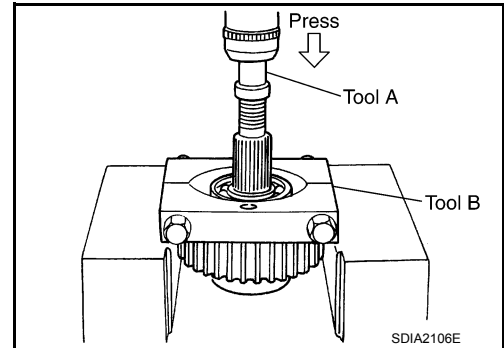

2. Remove the rear bearing using Tools.

Tool number (A): ST33710000 (—)
(B): ST30021000 (J-22912-01)

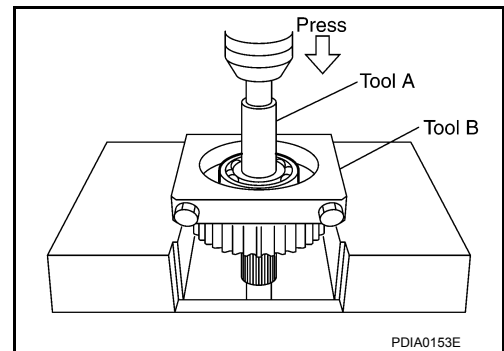

INSPECTION AFTER DISASSEMBLY

Front Drive Shaft

Check the items below. If necessary, replace them with new ones.

- Damage, peeling, dent, uneven wear and bending of the shaft.
- Excessive wear, damage and peeling of the gear.

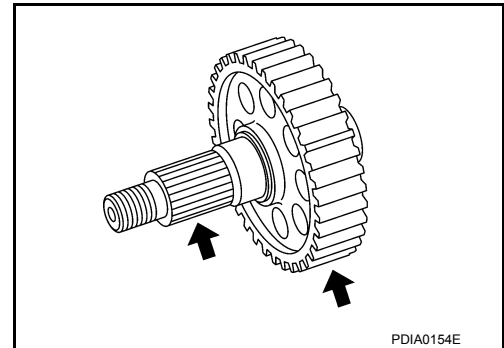

Bearing

Check the bearing for damage and rough rotation. If necessary, replace the bearing with a new one.

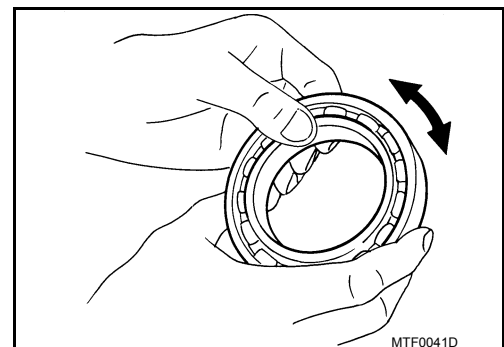

ASSEMBLY

A
B
C
DLN
E
F
G
H
I
J
K
L
M
N
O
P

FRONT DRIVE SHAFT

< UNIT DISASSEMBLY AND ASSEMBLY >

[TRANSFER: TX15B]

1. Install the rear bearing using Tools.

Tool number (A): KV38100500 (—)
(B): ST30901000 (J-26010-01)

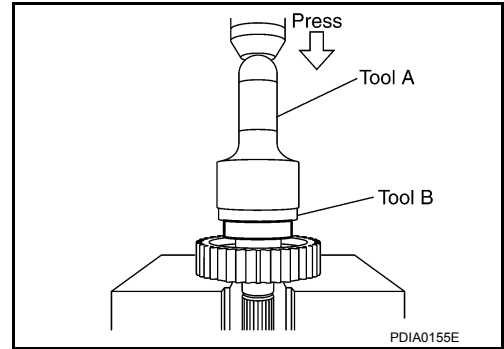

2. Install the front bearing using Tools.

Tool number (A): KV38100500 (—)
(B): ST30901000 (J-26010-01)

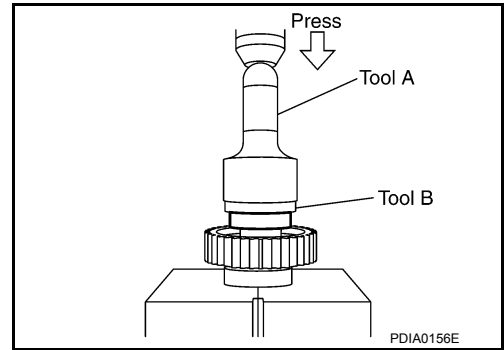

SHIFT CONTROL

< UNIT DISASSEMBLY AND ASSEMBLY >

[TRANSFER: TX15B]

SHIFT CONTROL

Disassembly and Assembly

INFOID:000000007323942

DISASSEMBLY (A/T MODELS)

1. Remove the snap ring.
CAUTION:
Do not reuse snap ring.
2. Remove the retaining pin.
CAUTION:
Do not reuse retaining pin.
3. Remove the drum cam from the control shift rod.

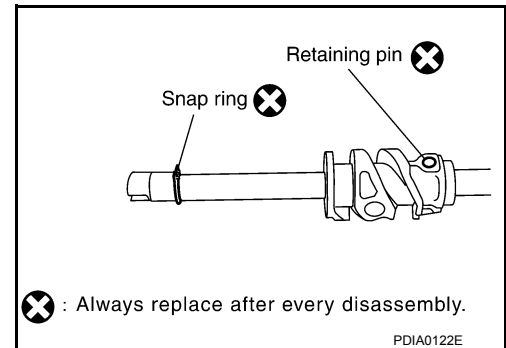

4. Remove the retaining pin from the L-H shift rod.
CAUTION:
Do not reuse retaining pin.
5. Remove the 2-4 shift bracket.

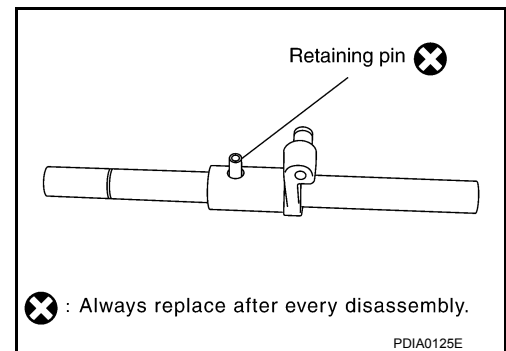

6. Remove the retaining ring from the 2-4 shift fork, using suitable tool.
CAUTION:
Do not reuse retaining ring.
7. Remove the fork guide collar and 2-4 shift fork spring from the 2-4 shift fork.

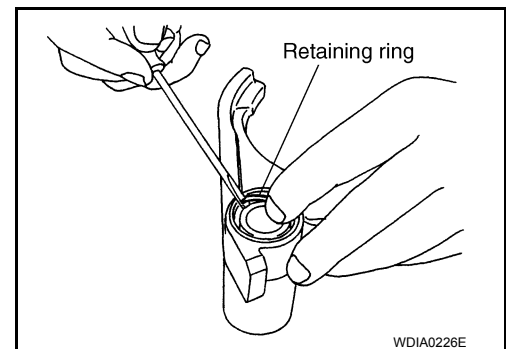

DISASSEMBLY (M/T MODELS)

1. Remove the retaining ring from the 2-4 shift fork, using suitable tool.
CAUTION:
Do not reuse retaining ring.
2. Remove the fork guide collar and 2-4 shift fork spring from the 2-4 shift fork.

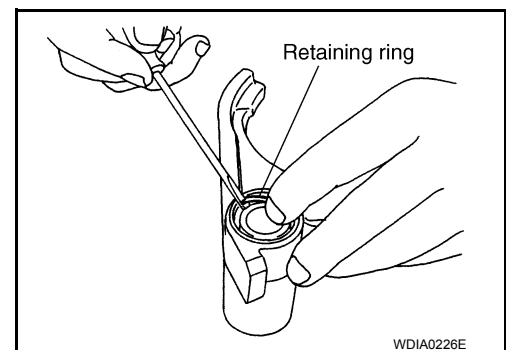

INSPECTION AFTER DISASSEMBLY

Shift Fork

A
B
C
DLN
E
F
G
H
I
J
K
L
M
N
O
P

SHIFT CONTROL

< UNIT DISASSEMBLY AND ASSEMBLY >

[TRANSFER: TX15B]

- Measure the clearance between the shift fork and sleeve. If it is out of specification, replace it with a new one.

Standard value

2-4 : Refer to [DLN-132, "Inspection and Adjustment"](#)

L-H : Refer to [DLN-132, "Inspection and Adjustment"](#)

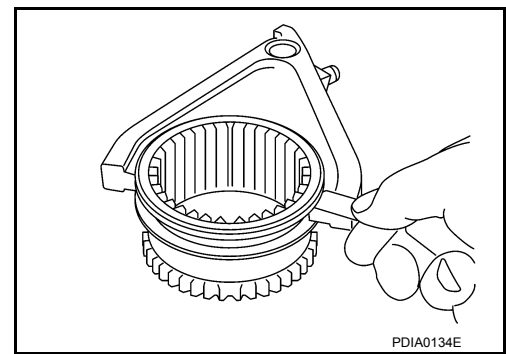

Shift Rod and Fork Components

- Check the working face of the shift rod and fork for wear, partial wear, abrasion, bending and other abnormality. If any is found, replace with a new one.

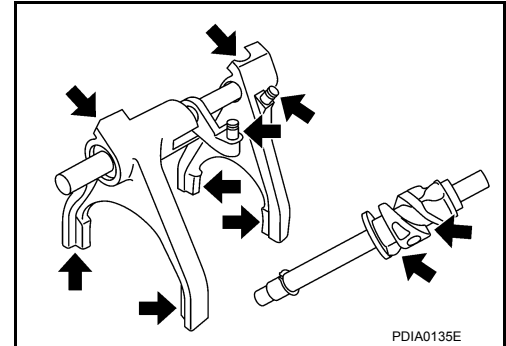

ASSEMBLY (A/T MODELS)

1. Install clevis pin and shift collar to L-H shift fork after assembling them.

CAUTION:

Use caution when installing L-H shift fork, clevis pin or shift collar.

2. Install clevis pin and shift collar to 2-4 shift bracket after assembling them.

CAUTION:

Use caution when installing 2-4 shift bracket.

3. Install the fork guide collar and 2-4 shift fork spring to the 2-4 shift fork, and then secure it with the retaining ring.

CAUTION:

- Do not reuse retaining ring.
- Be careful with orientation.

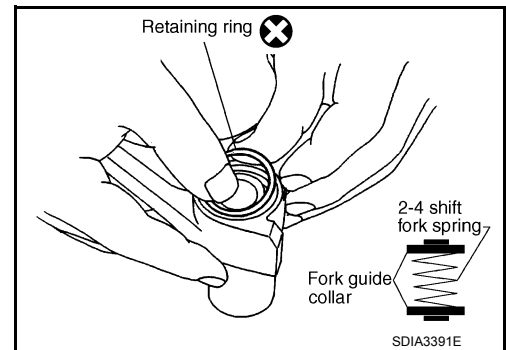

4. Install the 2-4shift bracket to the L-H shift rod.
5. Install the retaining pin evenly to the L-H shift rod.

CAUTION:

Do not reuse retaining pin.

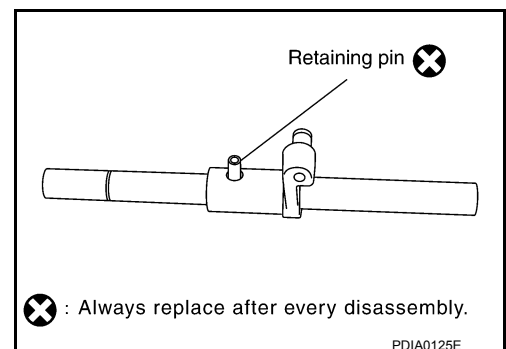

⊗ : Always replace after every disassembly.

SHIFT CONTROL

< UNIT DISASSEMBLY AND ASSEMBLY >

[TRANSFER: TX15B]

6. Install the drum cam to the control shift rod, and then secure it with the retaining pin.

CAUTION:

Do not reuse retaining pin.

7. Install the snap ring to the control shift rod.

CAUTION:

Do not reuse snap ring.

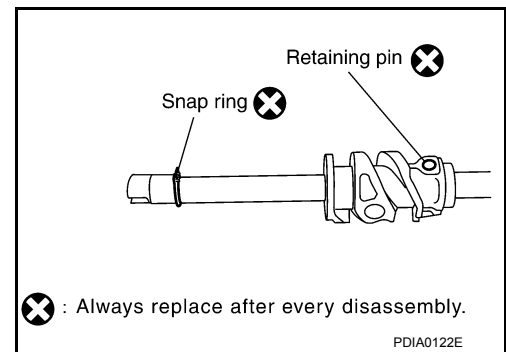

ASSEMBLY (M/T MODELS)

1. Install clevis pin and shift collar to L-H shift fork after assembling them.

CAUTION:

Use caution when installing L-H shift fork, clevis pin or shift collar.

2. Install clevis pin and shift collar to 2-4 shift bracket after assembling them.

CAUTION:

Use caution when installing 2-4 shift bracket.

3. Install the fork guide collar and 2-4 shift fork spring to the 2-4 shift fork, and then secure it with the retaining ring.

CAUTION:

- Do not reuse retaining ring.
- Be careful with orientation.

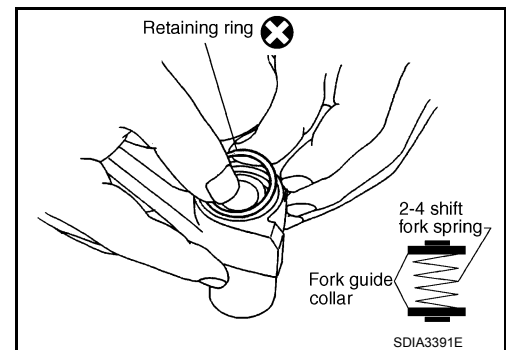

A

B

C

DLN

E

F

G

H

I

J

K

L

M

N

O

P

SERVICE DATA AND SPECIFICATIONS (SDS)

< SERVICE DATA AND SPECIFICATIONS (SDS)

[TRANSFER: TX15B]

SERVICE DATA AND SPECIFICATIONS (SDS)

SERVICE DATA AND SPECIFICATIONS (SDS)

General Specification

INFOID:000000007323943

Applied model	VQ40DE		
Transfer model	TX15B		
Gear ratio	High	1.000	
	Low	2.625	
Number of teeth	Planetary gear	Sun gear	56
		Internal gear	91
	Front drive sprocket		38
	Front drive shaft		38
Fluid Capacity (Approx)	ℓ (US qt, Imp qt)	2.0 (2 1/8, 1 3/4)	

Inspection and Adjustment

INFOID:000000007323944

PINION GEAR END PLAY

Unit: mm (in)

Item	Standard
Pinion gear end play	0.1 - 0.7 (0.004 - 0.028)

CLEARANCE BETWEEN SHIFT FORK AND SLEEVE

Unit: mm (in)

Item	Standard
2-4 shift fork to 2-4 sleeve	Less than 0.46 (0.018)
L-H shift fork to L-H sleeve	Less than 0.46 (0.018)

PRECAUTION

PRECAUTIONS

Precaution for Supplemental Restraint System (SRS) "AIR BAG" and "SEAT BELT PRE-TENSIONER"

INFOID:000000007323945

The Supplemental Restraint System such as "AIR BAG" and "SEAT BELT PRE-TENSIONER", used along with a front seat belt, helps to reduce the risk or severity of injury to the driver and front passenger for certain types of collision. This system includes seat belt switch inputs and dual stage front air bag modules. The SRS system uses the seat belt switches to determine the front air bag deployment, and may only deploy one front air bag, depending on the severity of a collision and whether the front occupants are belted or unbelted. Information necessary to service the system safely is included in the SR and SB section of this Service Manual.

WARNING:

- To avoid rendering the SRS inoperative, which could increase the risk of personal injury or death in the event of a collision which would result in air bag inflation, all maintenance must be performed by an authorized NISSAN/INFINITI dealer.
- Improper maintenance, including incorrect removal and installation of the SRS, can lead to personal injury caused by unintentional activation of the system. For removal of Spiral Cable and Air Bag Module, see the SR section.
- Do not use electrical test equipment on any circuit related to the SRS unless instructed to in this Service Manual. SRS wiring harnesses can be identified by yellow and/or orange harnesses or harness connectors.

PRECAUTIONS WHEN USING POWER TOOLS (AIR OR ELECTRIC) AND HAMMERS

WARNING:

- When working near the Airbag Diagnosis Sensor Unit or other Airbag System sensors with the Ignition ON or engine running, DO NOT use air or electric power tools or strike near the sensor(s) with a hammer. Heavy vibration could activate the sensor(s) and deploy the air bag(s), possibly causing serious injury.
- When using air or electric power tools or hammers, always switch the Ignition OFF, disconnect the battery, and wait at least 3 minutes before performing any service.

A
B
C
DLN
E
F
G
H
I
J
K
L
M
N
O
P

PREPARATION

< PREPARATION >

[PROPELLER SHAFT: 2F1310]

PREPARATION

PREPARATION

Commercial Service Tool

INFOID:000000007323946

Tool name	Description
<p data-bbox="146 409 267 441">Power tool</p>  <p data-bbox="836 619 909 651">PIIB1407E</p>	<p data-bbox="998 409 1347 441">Loosening nuts, screws and bolts</p>

NOISE, VIBRATION, AND HARSHNESS (NVH) TROUBLESHOOTING

< SYSTEM DESCRIPTION >

[PROPELLER SHAFT: 2F1310]

SYSTEM DESCRIPTION

NOISE, VIBRATION, AND HARSHNESS (NVH) TROUBLESHOOTING

NVH Troubleshooting Chart

INFOID:000000007323947

Use the chart below to help you find the cause of the symptom. If necessary, repair or replace these parts.

Symptom	Possible cause and suspected parts											
	Uneven rotation torque	Rotation imbalance	Excessive run out	Differential	Axle	Suspension	Tires	Road wheel	Drive shaft	Brakes	Steering	
Noise	x	x	x	x	x	x	x	x	x	x	x	x
Shake					x	x	x	x	x	x		x
Vibration	x	x	x		x	x	x		x			x

x: Applicable

A
B
C
DLN
E
F
G
H
I
J
K
L
M
N
O
P

BASIC INSPECTION

PROPELLER SHAFT ASSEMBLY

Inspection

INFOID:000000007323948

APPEARANCE AND NOISE INSPECTION

- Check the propeller shaft tube surface for dents or cracks. If damaged, replace the propeller shaft assembly.
- Check the bearings for noise and damage. Repair or replace the bearings as necessary.

PROPELLER SHAFT VIBRATION

If a vibration is present at high speed, inspect the propeller shaft runout first.

1. Measure the runout of the propeller shaft tube at several points by rotating the final drive companion flange with your hands. Refer to [DLN-141, "General Specification"](#).

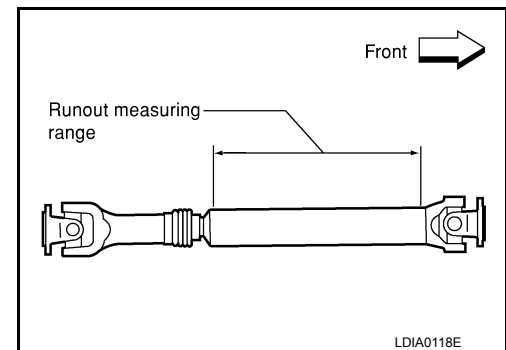
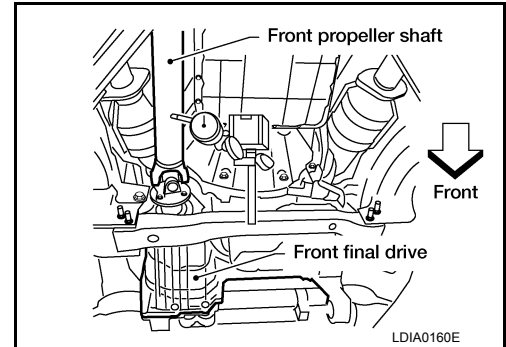

2. If the runout exceeds specifications, disconnect the propeller shaft at the final drive companion flange; then rotate the companion flange 90°, 180° and 270° and reconnect the propeller shaft.
3. Check the runout again. If the runout still exceeds specifications, replace the propeller shaft assembly.
4. After installation, check for vibration by driving the vehicle.

PROPELLER SHAFT

< UNIT REMOVAL AND INSTALLATION >

[PROPELLER SHAFT: 2F1310]

UNIT REMOVAL AND INSTALLATION

PROPELLER SHAFT

Removal and Installation

INFOID:000000007323949

COMPONENTS

Model 2F1310

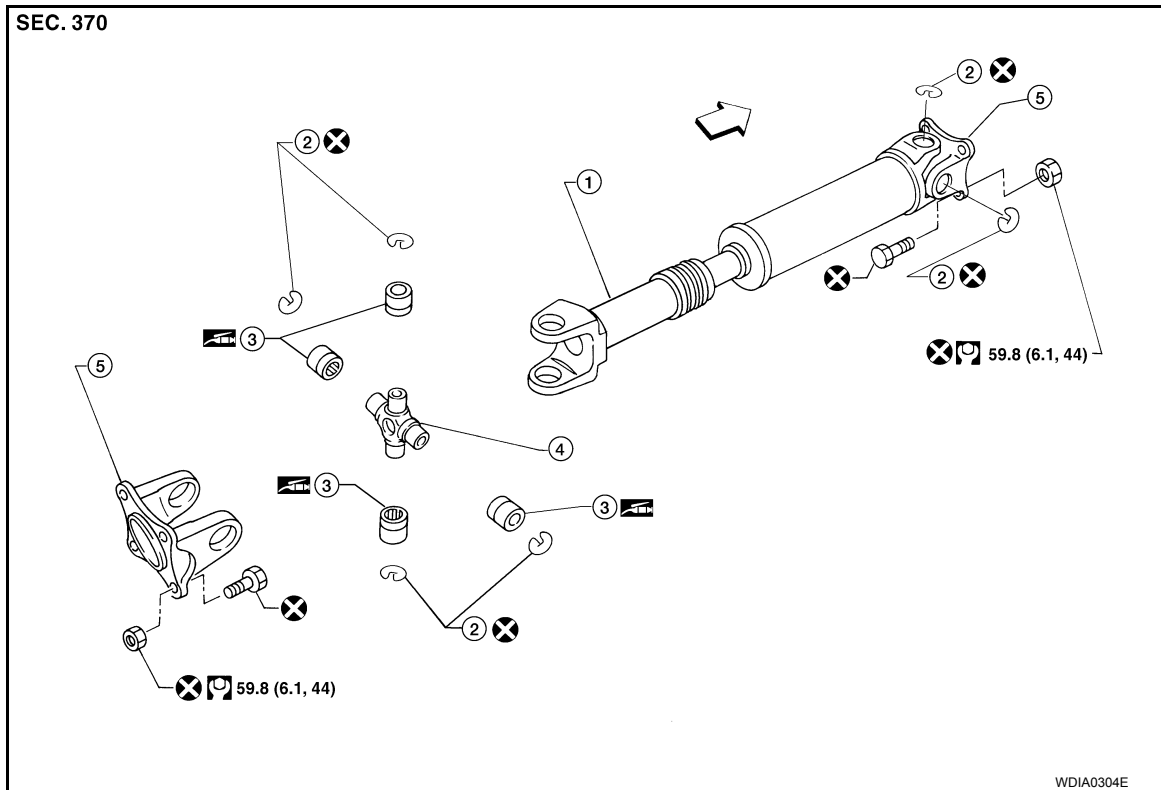

- | | | |
|-------------------------|----------------|--------------------|
| 1. Propeller shaft tube | 2. Snap ring | 3. Journal bearing |
| 4. Journal | 5. Flange yoke | ⇐ Front |

REMOVAL

1. Remove under cover (if equipped).
2. Put matching marks on the front propeller shaft flange yoke and the front final drive companion flange as shown.

CAUTION:

For matching marks, use paint. Do not damage the flange yoke and companion flange of the front final drive.

3. Put matching marks on the front propeller shaft flange yoke and the transfer companion flange.

CAUTION:

For matching marks, use paint. Do not damage the flange yoke and companion flange of the front final drive.

4. Remove the bolts and then remove the front propeller shaft from the front final drive and transfer.

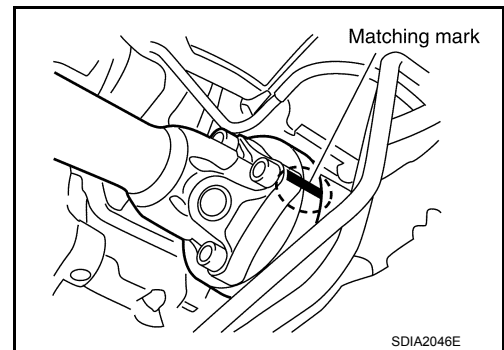

INSPECTION

A
B
C
DLN
E
F
G
H
I
J
K
L
M
N
O
P

PROPELLER SHAFT

< UNIT REMOVAL AND INSTALLATION >

[PROPELLER SHAFT: 2F1310]

- Inspect the propeller shaft runout. If runout exceeds the limit, replace the propeller shaft assembly. Refer to [DLN-141, "General Specification"](#).

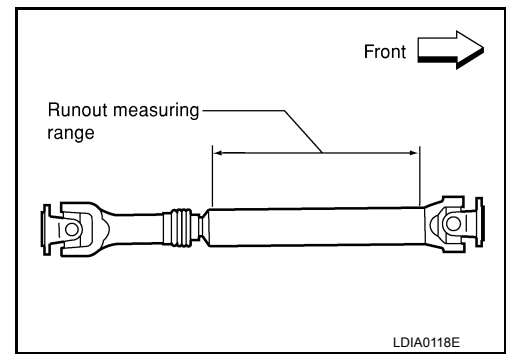

- While holding the flange yoke on one side, check axial play of the joint as shown. If the journal axial play exceeds the specification, repair or replace the journal parts. Refer to [DLN-141, "General Specification"](#).
- Check the propeller shaft tube surface for dents or cracks. If damage is detected, replace the propeller shaft assembly.

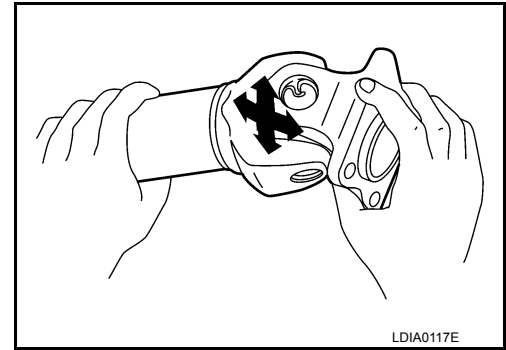

INSTALLATION

Installation is in the reverse order of removal.

- After installation, check for vibration by driving the vehicle. Refer to [DLN-135, "NVH Troubleshooting Chart"](#).

CAUTION:

Do not reuse the bolts and nuts. Always install new ones.

PROPELLER SHAFT

< UNIT DISASSEMBLY AND ASSEMBLY >

[PROPELLER SHAFT: 2F1310]

UNIT DISASSEMBLY AND ASSEMBLY

PROPELLER SHAFT

Disassembly and Assembly

INFOID:000000007323950

DISASSEMBLY

Journal

1. Put matching marks on the front propeller shaft and flange yoke as shown.

CAUTION:

For matching marks, use paint. Do not damage the front propeller shaft or flange yoke.

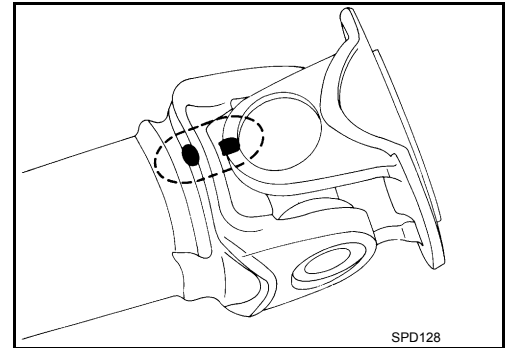

2. Remove the snap rings.

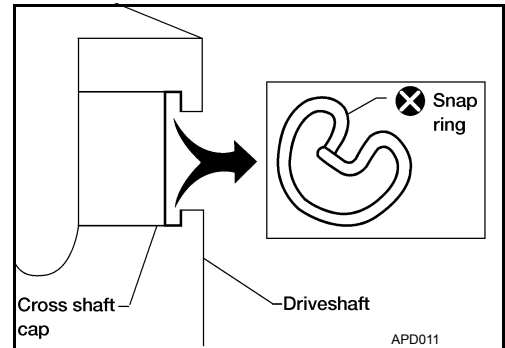

3. Push out and remove the journal bearings by lightly tapping the flange yoke with a hammer, taking care not to damage the journal or flange yoke hole.

NOTE:

Put marks on the disassembled parts so that they can be reinstalled in their original positions from which they were removed.

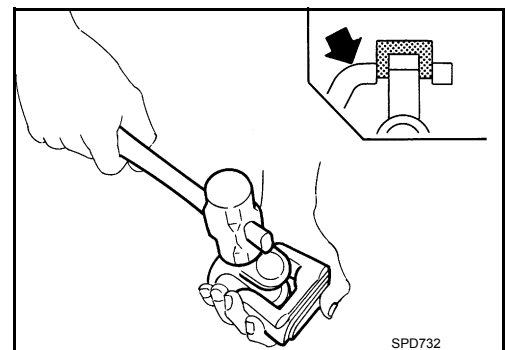

4. Push out and remove the remaining journal bearings at the opposite side by lightly tapping the flange yoke with a hammer, taking care not to damage the journal or flange yoke hole.

NOTE:

Put marks on the disassembled parts so that they can be reinstalled in their original positions from which they were removed.

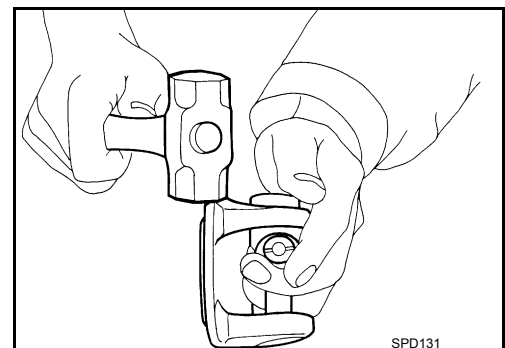

ASSEMBLY

A
B
C
DLN
E
F
G
H
I
J
K
L
M
N
O
P

PROPELLER SHAFT

< UNIT DISASSEMBLY AND ASSEMBLY >

[PROPELLER SHAFT: 2F1310]

Journal

1. Assemble the journal bearings. Apply multipurpose grease on the bearing inner surface.

NOTE:

During assembly, use caution so that the needle bearings do not fall down.

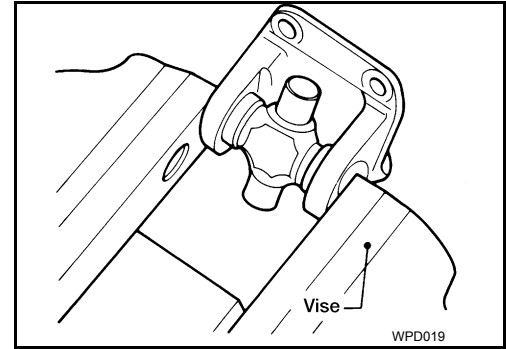

2. Select new snap rings that will provide the specified play in an axial direction of the journal, and install them. Refer to [DLN-141](#).

"Snap Ring":

CAUTION:

Do not reuse snap rings

NOTE:

Select snap rings with a difference in thickness at both sides within 0.02 mm (0.0008 in).

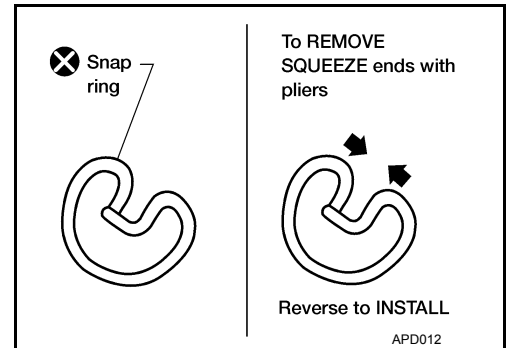

3. Adjust the thrust clearance between the bearing and snap ring to zero by tapping the yoke.

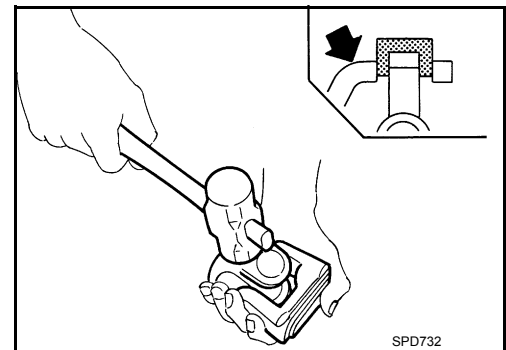

4. Make sure that the journal moves smoothly and is below the joint flex effort specification. Refer to [DLN-141](#). "[General Specification](#)".

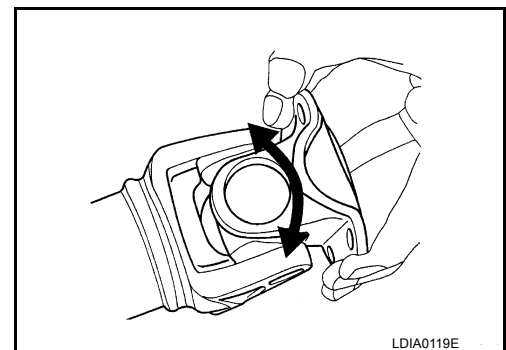

SERVICE DATA AND SPECIFICATIONS (SDS)

< SERVICE DATA AND SPECIFICATIONS (SDS)

[PROPELLER SHAFT: 2F1310]

SERVICE DATA AND SPECIFICATIONS (SDS)

SERVICE DATA AND SPECIFICATIONS (SDS)

General Specification

INFOID:000000007323951

Applied model		VQ40DE
		4WD
Front	Propeller shaft model	2F1310
	Number of joints	2
	Coupling method with front final drive	Flange type
	Coupling method with transfer	Flange type
	Shaft length (Spider to spider)	696 ± 1.5 mm (27.40 ± 0.06 in)
	Shaft outer diameter	63.5 + 0.00/- 0.13 mm (2.5 + 0.00/- 0.01 in)
	Journal axial play	0.02 mm (0.0008 in) or less
	Propeller shaft runout limit	0.6 mm (0.024 in) or less
	Propeller shaft joint flex effort	2.26 N·m (0.23 kg·m, 20 in·lb) or less

Snap Ring

INFOID:000000007323952

Unit: mm (in)

Thickness	Color	Part Number*
1.99 (0.0783)	White	37146-C9400
2.02 (0.0795)	Yellow	37147-C9400
2.05 (0.0807)	Red	37148-C9400
2.08 (0.0819)	Green	37149-C9400
2.11 (0.0831)	Blue	37150-C9400
2.14 (0.0843)	Light brown	37151-C9400
2.17 (0.0854)	Black	37152-C9400
2.20 (0.0866)	No paint	37153-C9400

*: Always check with the Parts Department for the latest parts information.

PRECAUTION

PRECAUTIONS

Precaution for Supplemental Restraint System (SRS) "AIR BAG" and "SEAT BELT PRE-TENSIONER"

INFOID:000000007323953

The Supplemental Restraint System such as "AIR BAG" and "SEAT BELT PRE-TENSIONER", used along with a front seat belt, helps to reduce the risk or severity of injury to the driver and front passenger for certain types of collision. This system includes seat belt switch inputs and dual stage front air bag modules. The SRS system uses the seat belt switches to determine the front air bag deployment, and may only deploy one front air bag, depending on the severity of a collision and whether the front occupants are belted or unbelted. Information necessary to service the system safely is included in the SR and SB section of this Service Manual.

WARNING:

- To avoid rendering the SRS inoperative, which could increase the risk of personal injury or death in the event of a collision which would result in air bag inflation, all maintenance must be performed by an authorized NISSAN/INFINITI dealer.
- Improper maintenance, including incorrect removal and installation of the SRS, can lead to personal injury caused by unintentional activation of the system. For removal of Spiral Cable and Air Bag Module, see the SR section.
- Do not use electrical test equipment on any circuit related to the SRS unless instructed to in this Service Manual. SRS wiring harnesses can be identified by yellow and/or orange harnesses or harness connectors.

PRECAUTIONS WHEN USING POWER TOOLS (AIR OR ELECTRIC) AND HAMMERS

WARNING:

- When working near the Airbag Diagnosis Sensor Unit or other Airbag System sensors with the Ignition ON or engine running, DO NOT use air or electric power tools or strike near the sensor(s) with a hammer. Heavy vibration could activate the sensor(s) and deploy the air bag(s), possibly causing serious injury.
- When using air or electric power tools or hammers, always switch the Ignition OFF, disconnect the battery, and wait at least 3 minutes before performing any service.

PREPARATION

< PREPARATION >

[PROPELLER SHAFT: 2S1330]

PREPARATION

PREPARATION

Commercial Service Tool

INFOID:000000007323954

Tool name	Description
Power tool  PIIB1407E	Loosening nuts, screws and bolts

A

B

C

DLN

E

F

G

H

I

J

K

L

M

N

O

P

NOISE, VIBRATION, AND HARSHNESS (NVH) TROUBLESHOOTING

< SYSTEM DESCRIPTION >

[PROPELLER SHAFT: 2S1330]

SYSTEM DESCRIPTION

NOISE, VIBRATION, AND HARSHNESS (NVH) TROUBLESHOOTING

NVH Troubleshooting Chart

INFOID:000000007323955

Use the chart below to help you find the cause of the symptom. If necessary, repair or replace these parts.

Symptom		Possible cause and suspected parts										
		Uneven rotation torque	Rotation imbalance	Excessive run out	Differential	Axle	Suspension	Tires	Road wheel	Drive shaft	Brakes	Steering
Noise		x	x	x	x	x	x	x	x	x	x	x
Shake						x	x	x	x	x	x	x
Vibration		x	x	x		x	x	x		x		x

x: Applicable

Reference page											
	DLN-145	DLN-145	DLN-150	DLN-187, "NVH Troubleshooting Chart" DLN-221, "NVH Troubleshooting Chart" DLN-253, "NVH Troubleshooting Chart" DLN-277, "NVH Troubleshooting Chart"	FAX-4, "NVH Troubleshooting Chart" RAX-5, "NVH Troubleshooting Chart" RAX-17, "NVH Troubleshooting Chart"	FSU-5, "NVH Troubleshooting Chart" RSU-4, "NVH Troubleshooting Chart"	WT-43, "NVH Troubleshooting Chart"	WT-43, "NVH Troubleshooting Chart"	DLN-135, "NVH Troubleshooting Chart" DLN-144, "NVH Troubleshooting Chart" DLN-144, "NVH Troubleshooting Chart"	BR-5, "NVH Troubleshooting Chart"	ST-5, "NVH Troubleshooting Chart"

PROPELLER SHAFT ASSEMBLY

< BASIC INSPECTION >

[PROPELLER SHAFT: 2S1330]

BASIC INSPECTION

PROPELLER SHAFT ASSEMBLY

Inspection

INFOID:000000007323956

APPEARANCE AND NOISE INSPECTION

- Check the propeller shaft tube surface for dents or cracks. If damaged, replace the propeller shaft assembly.
- Check the bearings for noise and damage. Repair or replace the bearings as necessary.

PROPELLER SHAFT VIBRATION

If a vibration is present at high speed, inspect the propeller shaft runout first.

1. Measure the runout of the propeller shaft tube at several points by rotating the final drive companion flange with your hands. Refer to [DLN-150, "General Specification"](#).

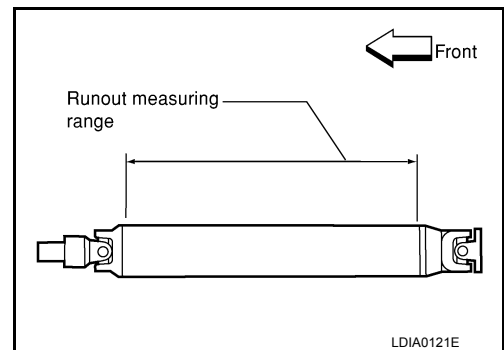
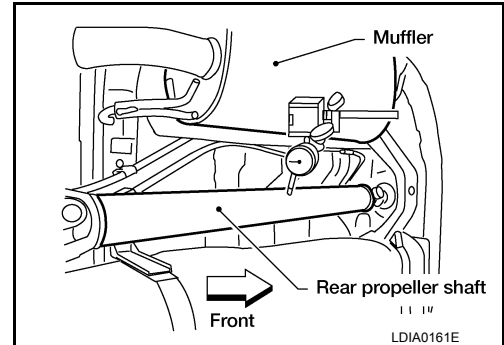

2. If the runout exceeds specifications, disconnect the propeller shaft at the final drive companion flange; then rotate the companion flange 90°, 180° and 270° and reconnect the propeller shaft.
3. Check the runout again. If the runout still exceeds specifications, replace the propeller shaft assembly.
4. After installation, check for vibration by driving vehicle.

PROPELLER SHAFT

< UNIT REMOVAL AND INSTALLATION >

[PROPELLER SHAFT: 2S1330]

UNIT REMOVAL AND INSTALLATION

PROPELLER SHAFT

Removal and Installation

INFOID:000000007323957

COMPONENTS

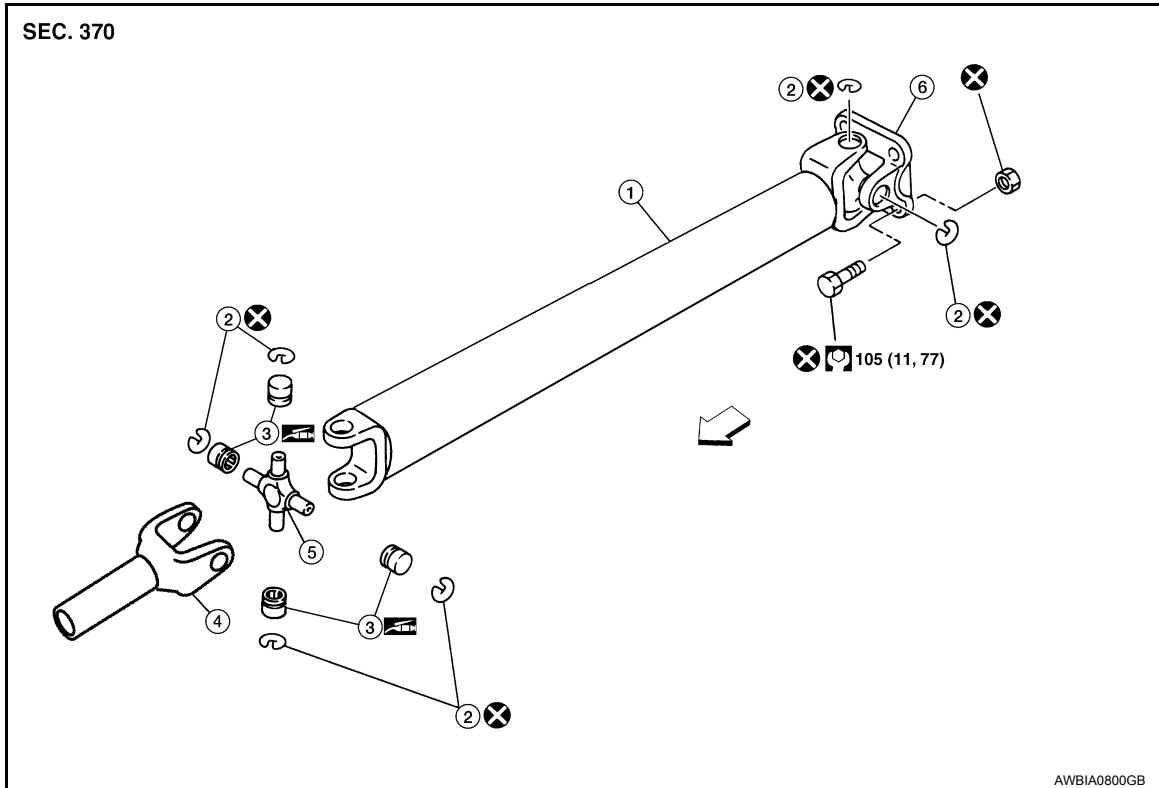

- | | | |
|-------------------------|--------------|--------------------|
| 1. Propeller shaft tube | 2. Snap ring | 3. Journal bearing |
| 4. Sleeve yoke | 5. Journal | 6. Flange yoke |
- ← Front

NOTE:

When removing components such as hoses, tubes/lines, etc., cap or plug openings to prevent fluid from spilling.

REMOVAL

1. Remove under cover (if equipped).
2. Put transmission in neutral and release the parking brake.
3. Put matching marks on the rear propeller shaft flange yoke and the rear final drive companion flange as shown.

CAUTION:

For matching marks, use paint. Do not damage the rear propeller shaft flange yoke or the companion flange.

4. Remove the bolts, then remove the propeller shaft from the rear final drive and transfer.

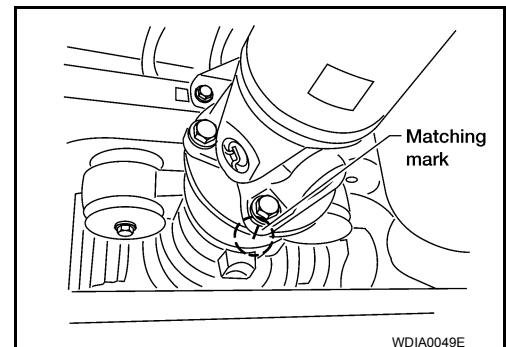

INSPECTION

PROPELLER SHAFT

< UNIT REMOVAL AND INSTALLATION >

[PROPELLER SHAFT: 2S1330]

- Inspect the propeller shaft runout. If runout exceeds the limit, replace the propeller shaft assembly. Refer to [DLN-150, "General Specification"](#).

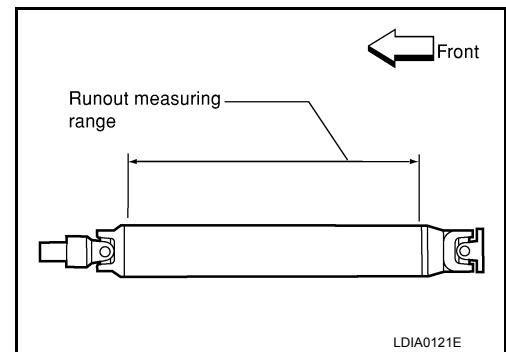

- While holding the flange yoke on one side, check axial play of the joint as shown. If the journal axial play exceeds the specification, repair or replace the journal parts. Refer to [DLN-150, "General Specification"](#).
- Check the propeller shaft tube for dents or cracks. If damage is detected, replace the propeller shaft assembly.

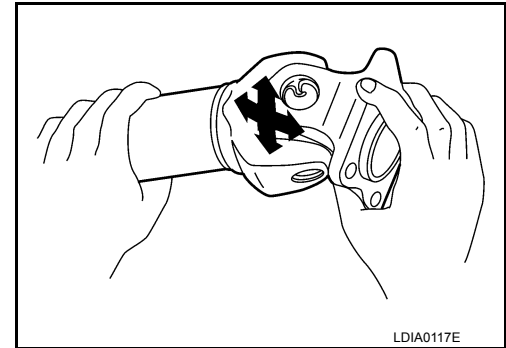

INSTALLATION

Installation is in the reverse order of removal.

- After installation, check for vibration by driving the vehicle. Refer to [DLN-144, "NVH Troubleshooting Chart"](#).
- If propeller shaft assembly or final drive assembly has been replaced, connect them as follows:
 - Face companion flange mark (A) of the final drive (1) upward. With the mark (A) faced upward, couple the propeller shaft and the final drive so that the matching mark (B) of the propeller shaft (2) can be positioned as closest as possible with the matching mark (C) of the final drive companion flange.
 - Tighten propeller shaft and final drive bolts and nuts to specifications. Refer to [DLN-146, "Removal and Installation"](#).

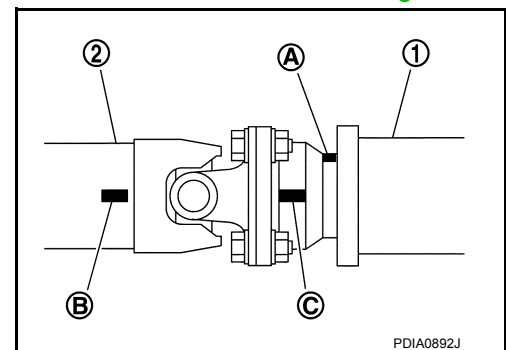

CAUTION:

Do not reuse the bolts and nuts. Always install new ones.

PROPELLER SHAFT

< UNIT DISASSEMBLY AND ASSEMBLY >

[PROPELLER SHAFT: 2S1330]

UNIT DISASSEMBLY AND ASSEMBLY

PROPELLER SHAFT

Disassembly and Assembly

INFOID:000000007323958

DISASSEMBLY

Journal

1. Put matching marks on the rear propeller shaft and flange yoke as shown.

CAUTION:

For matching marks use paint. Do not damage the rear propeller shaft or flange yoke.

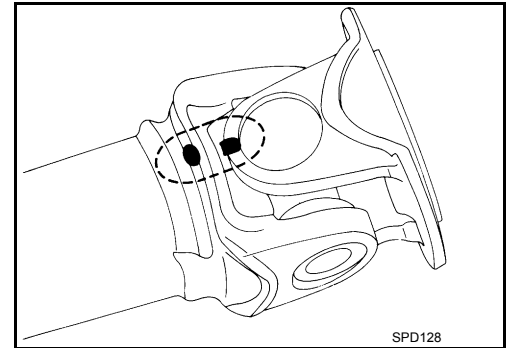

2. Remove the snap rings.

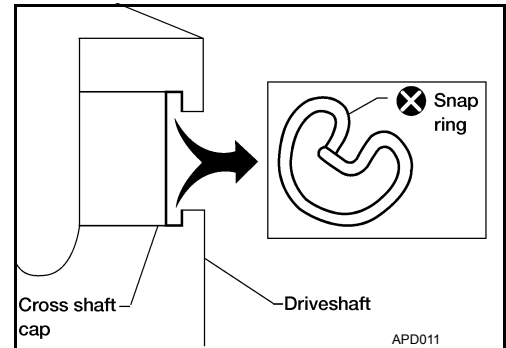

3. Push out and remove the journal bearings by lightly tapping the flange yoke with a hammer, taking care not to damage the journal or flange yoke hole.

NOTE:

Put marks on the disassembled parts so that they can be reinstalled in their original positions from which they were removed.

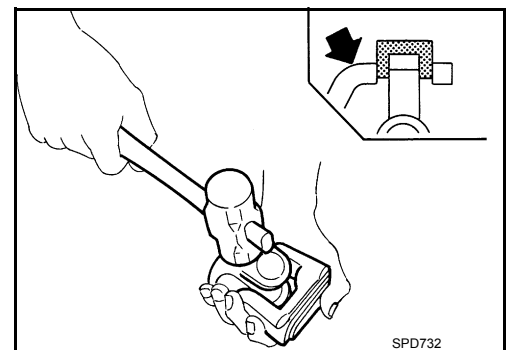

4. Push out and remove the remaining journal bearings at the opposite side by lightly tapping the flange yoke with a hammer, taking care not to damage the journal or flange yoke hole.

NOTE:

Put marks on the disassembled parts so that they can be reinstalled in their original positions from which they were removed.

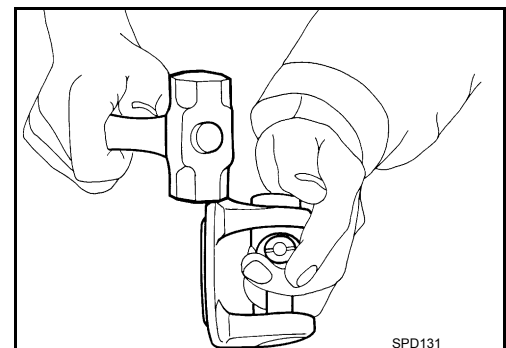

ASSEMBLY

PROPELLER SHAFT

< UNIT DISASSEMBLY AND ASSEMBLY >

[PROPELLER SHAFT: 2S1330]

Journal

1. Assemble the journal bearings. Apply multipurpose grease on the bearing inner surface.

NOTE:

During assembly, use caution so that the needle bearings do not fall down.

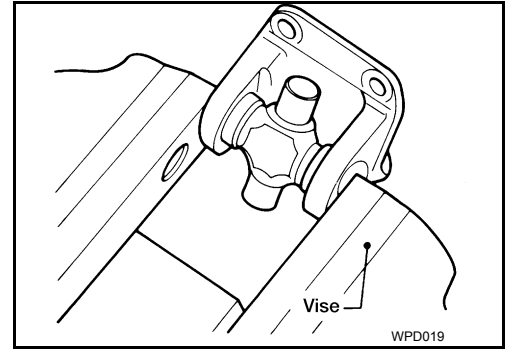

2. Select new snap rings that will provide the specified play in an axial direction of the journal, and install them. Refer to [DLN-150](#).

"Snap Ring".

CAUTION:

Do not reuse snap rings

NOTE:

Select snap rings with a difference in thickness at both sides within 0.02 mm (0.0008 in).

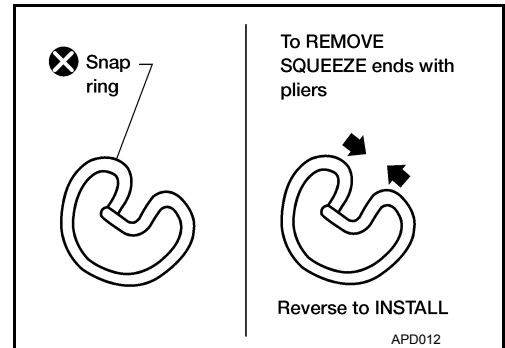

3. Adjust the thrust clearance between the bearing and snap ring to zero by tapping the yoke.

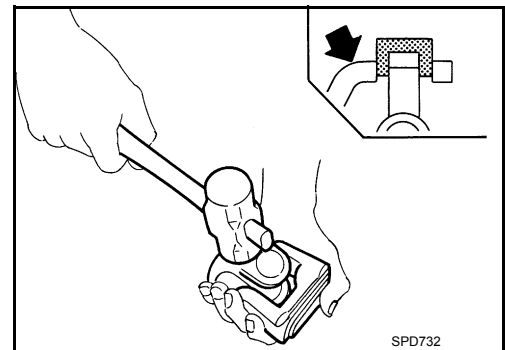

4. Make sure that the journal moves smoothly and is below the propeller joint flex effort specification. Refer to [DLN-150](#). "[General Specification](#)".

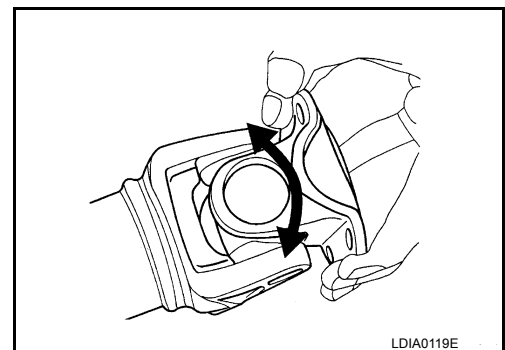

A
B
C
DLN
E
F
G
H
I
J
K
L
M
N
O
P

SERVICE DATA AND SPECIFICATIONS (SDS)

< SERVICE DATA AND SPECIFICATIONS (SDS)

[PROPELLER SHAFT: 2S1330]

SERVICE DATA AND SPECIFICATIONS (SDS)

SERVICE DATA AND SPECIFICATIONS (SDS)

General Specification

INFOID:000000007323959

Applied model	VQ40DE		
	4WD Short bed		
Transmission type	6M/T	5A/T	
Grade	SE, Off-Road	SE, LE	Off-Road
Number of pinion joints	2		
Coupling method with rear final drive	Flange type		
Coupling method with transmission	Sleeve type		
Shaft length (spider to spider)	1266.8 ± 1.5 mm (49.87 ± 0.06 in)	1280.8 ± 1.5 mm (50.43 ± 0.06 in)	1266.8 ± 1.5 mm (49.87 ± 0.06 in)
Shaft outer diameter	102.5 + 0.17/ -0.25 mm (4.00 ± 0.01 in)		
Journal axial play	0.02 mm (0.0008 in) or less		
Propeller shaft runout limit	1.02 mm (0.04 in) or less		
Propeller shaft joint flex effort	2.26 N·m (0.23 kg·m, 20 in·lb) or less		

Snap Ring

INFOID:000000007323960

Unit: mm (in)

Thickness	Color	Part Number*
1.600 - 1.638 (0.0630 - 0.0645)	Black	37146-EA500
1.549 - 1.588 (0.0610 - 0.0625)	Black	37147-EA500
1.524 - 1.562 (0.0600 - 0.0615)	Black	37148-EA500
1.499 - 1.537 (0.0590 - 0.0605)	Black	37149-EA500

*: Always check with the Parts Department for the latest parts information.

PRECAUTION

PRECAUTIONS

Precaution for Supplemental Restraint System (SRS) "AIR BAG" and "SEAT BELT PRE-TENSIONER"

INFOID:000000007323961

The Supplemental Restraint System such as "AIR BAG" and "SEAT BELT PRE-TENSIONER", used along with a front seat belt, helps to reduce the risk or severity of injury to the driver and front passenger for certain types of collision. This system includes seat belt switch inputs and dual stage front air bag modules. The SRS system uses the seat belt switches to determine the front air bag deployment, and may only deploy one front air bag, depending on the severity of a collision and whether the front occupants are belted or unbelted. Information necessary to service the system safely is included in the SR and SB section of this Service Manual.

WARNING:

- To avoid rendering the SRS inoperative, which could increase the risk of personal injury or death in the event of a collision which would result in air bag inflation, all maintenance must be performed by an authorized NISSAN/INFINITI dealer.
- Improper maintenance, including incorrect removal and installation of the SRS, can lead to personal injury caused by unintentional activation of the system. For removal of Spiral Cable and Air Bag Module, see the SR section.
- Do not use electrical test equipment on any circuit related to the SRS unless instructed to in this Service Manual. SRS wiring harnesses can be identified by yellow and/or orange harnesses or harness connectors.

PRECAUTIONS WHEN USING POWER TOOLS (AIR OR ELECTRIC) AND HAMMERS

WARNING:

- When working near the Airbag Diagnosis Sensor Unit or other Airbag System sensors with the Ignition ON or engine running, DO NOT use air or electric power tools or strike near the sensor(s) with a hammer. Heavy vibration could activate the sensor(s) and deploy the air bag(s), possibly causing serious injury.
- When using air or electric power tools or hammers, always switch the Ignition OFF, disconnect the battery, and wait at least 3 minutes before performing any service.

A
B
C
DLN
E
F
G
H
I
J
K
L
M
N
O
P

PREPARATION

< PREPARATION >

[PROPELLER SHAFT: 3S1310]

PREPARATION

PREPARATION

Special Service Tools

INFOID:000000007323962

Tool name	Description
205-D002 (—) Bearing splitter	Removing center support bearing assembly

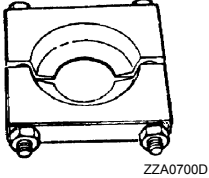

The diagram shows a square-shaped bearing splitter tool with a central circular opening and four mounting feet. The part number ZZA0700D is printed below the diagram.

Commercial Service Tool

INFOID:000000007323963

Tool name	Description
Power tool	Loosening nuts, screws and bolts



The diagram shows a power tool with a long handle and a specialized bit, along with several small components like nuts and bolts. The part number PIIB1407E is printed below the diagram.

NOISE, VIBRATION AND HARSHNESS (NVH) TROUBLESHOOTING

< SYSTEM DESCRIPTION >

[PROPELLER SHAFT: 3S1310]

SYSTEM DESCRIPTION

NOISE, VIBRATION AND HARSHNESS (NVH) TROUBLESHOOTING

NVH Troubleshooting Chart

INFOID:000000007323964

Use the chart below to help you find the cause of the symptom. If necessary, repair or replace these parts.

Symptom	Possible cause and suspected parts											
	Uneven rotation torque	Rotation imbalance	Excessive run out	Differential	Axle	Suspension	Tires	Road wheel	Drive shaft	Brakes	Steering	
Noise	x	x	x	x	x	x	x	x	x	x	x	x
Shake						x	x	x	x	x	x	x
Vibration	x	x	x			x	x	x		x		x

x: Applicable

A
B
C
DLN
E
F
G
H
I
J
K
L
M
N
O
P

DLN

BASIC INSPECTION

PROPELLER SHAFT ASSEMBLY

Inspection

INFOID:000000007323965

APPEARANCE AND NOISE INSPECTION

Check the propeller shaft tube surface for dents or cracks. If damaged, replace the propeller shaft assembly.

PROPELLER SHAFT VIBRATION

If a vibration is present at high speed, inspect the propeller shaft runout first.

1. Measure the runout of the propeller shaft tube at several points by rotating the final drive companion flange with your hands.

Propeller shaft runout limit

2WD Refer to [DLN-161, "General Specification"](#)

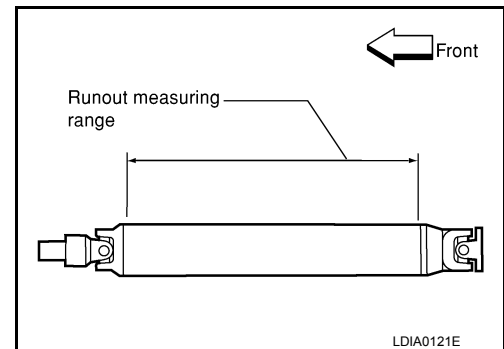
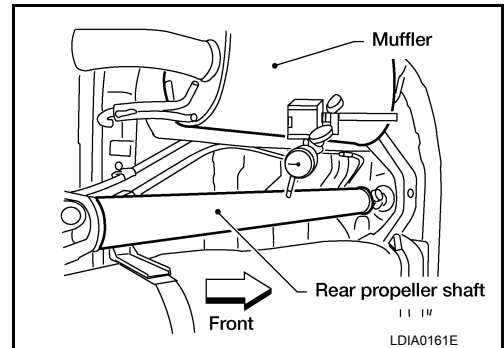

2. If the runout exceeds specifications, disconnect the propeller shaft at the final drive companion flange; then rotate the companion flange 90°, 180° and 270° and reconnect the propeller shaft.
3. Check the runout again. If the runout still exceeds specifications, replace the propeller shaft assembly.
4. After installation, check for vibration by driving vehicle.

REAR PROPELLER SHAFT

< UNIT REMOVAL AND INSTALLATION >

[PROPELLER SHAFT: 3S1310]

UNIT REMOVAL AND INSTALLATION

REAR PROPELLER SHAFT

Removal and Installation

INFOID:000000007323966

COMPONENTS

Model 3S1310

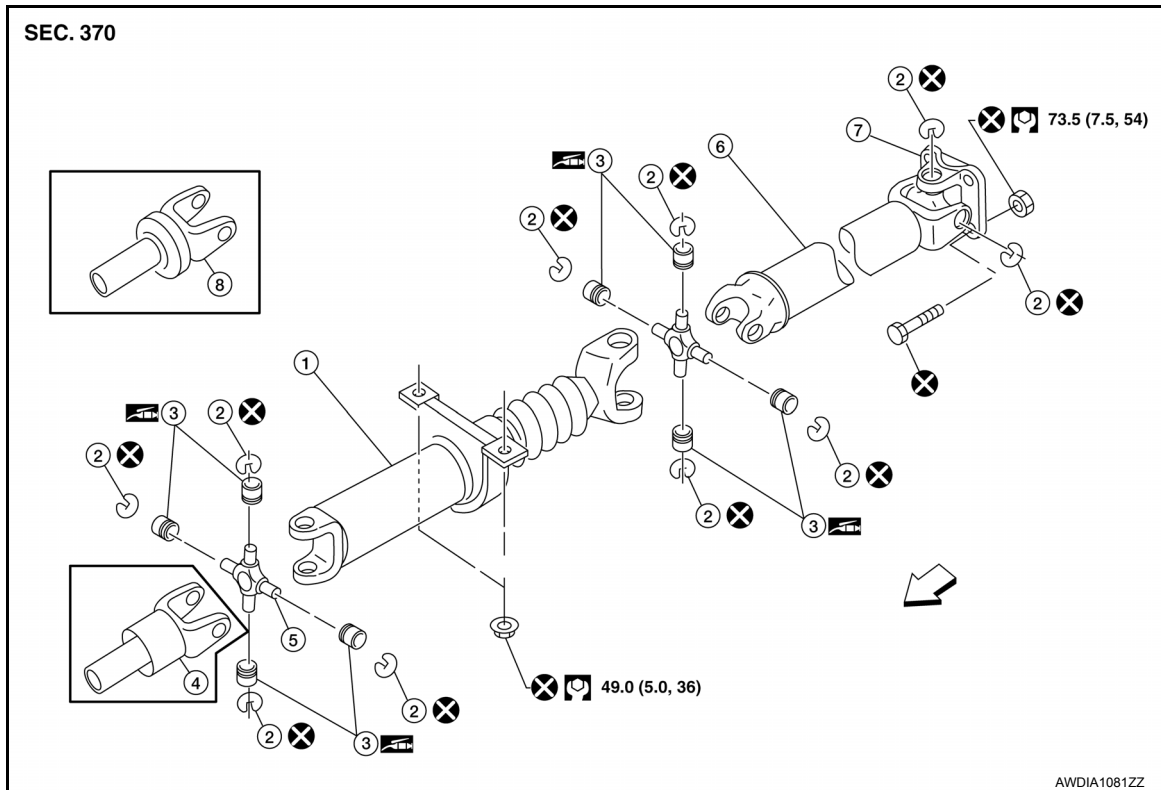

- | | | |
|--------------------------------|-----------------------|--------------------------------|
| 1. Propeller shaft (1st shaft) | 2. Snap ring | 3. Journal bearing |
| 4. Sleeve yoke (5A/T) | 5. Journal | 6. Propeller shaft (2nd shaft) |
| 7. Flange yoke | 8. Sleeve yoke (5M/T) | ↔ Front |

NOTE:

When removing components such as hoses, tubes/lines, etc., cap or plug openings to prevent fluid from spilling.

REMOVAL

1. Remove under cover (if equipped).
2. Put the transmission in neutral and release the parking brake.
3. Put matching marks on the rear propeller shaft flange yoke and the rear final drive companion flange as shown.

CAUTION:

For matching marks, use paint. Do not damage the rear propeller shaft flange yoke or the companion flange.

4. Remove the bolts, then remove the propeller shaft from the rear final drive and transmission.

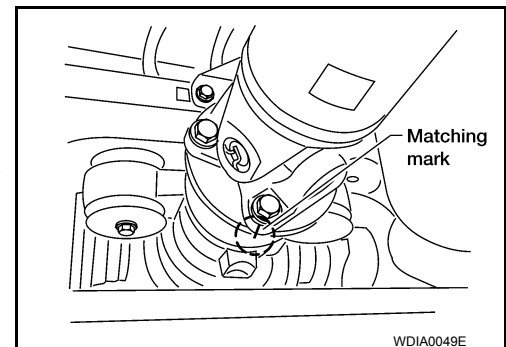

INSPECTION

REAR PROPELLER SHAFT

< UNIT REMOVAL AND INSTALLATION >

[PROPELLER SHAFT: 3S1310]

- Inspect the propeller shaft runout. If runout exceeds the limit, replace the propeller shaft assembly.

Propeller shaft runout limit

2WD : Refer to [DLN-161, "General Specification"](#)

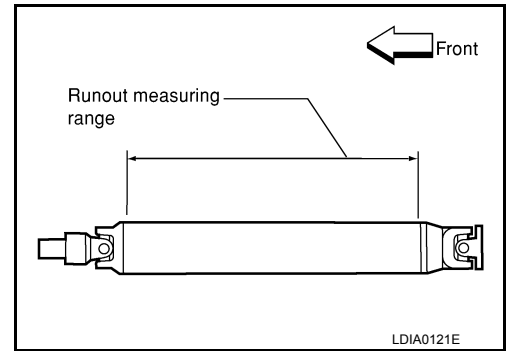

- While holding the flange yoke on one side, check axial play of the joint as shown. If the journal axial play exceeds the specification, repair or replace the journal parts.

Journal axial play : Refer to [DLN-161, "General Specification"](#)

- Check the propeller shaft for dents or cracks. If damage is detected, replace the propeller shaft assembly.

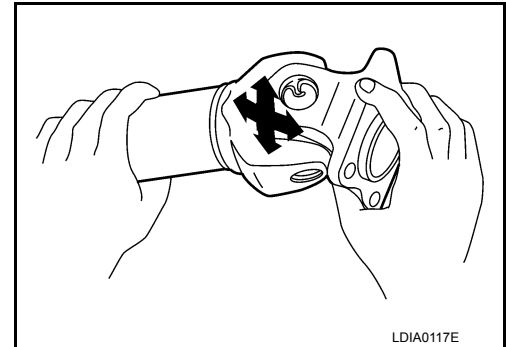

INSTALLATION

Installation is in the reverse order of removal.

- After installation, check for vibration by driving the vehicle. Refer to [DLN-153, "NVH Troubleshooting Chart"](#).

CAUTION:

Do not reuse the bolts and nuts. Always install new ones.

REAR PROPELLER SHAFT

< UNIT DISASSEMBLY AND ASSEMBLY >

[PROPELLER SHAFT: 3S1310]

UNIT DISASSEMBLY AND ASSEMBLY

REAR PROPELLER SHAFT

Disassembly and Assembly

INFOID:000000007323967

DISASSEMBLY

Journal

1. Remove the propeller shaft assembly from the vehicle. Refer to [DLN-155. "Removal and Installation"](#).
2. Put matching marks on the rear propeller shaft tube and flange yoke as shown.

CAUTION:

For matching marks use paint. Do not damage the rear propeller shaft or flange yoke.

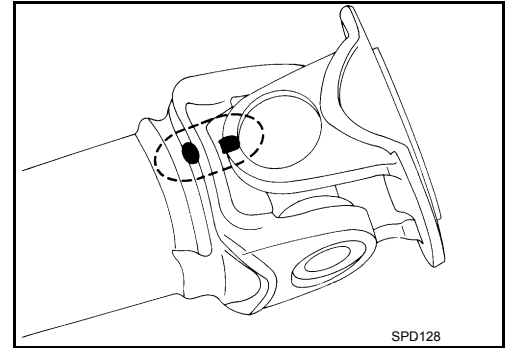

3. Remove the snap rings.

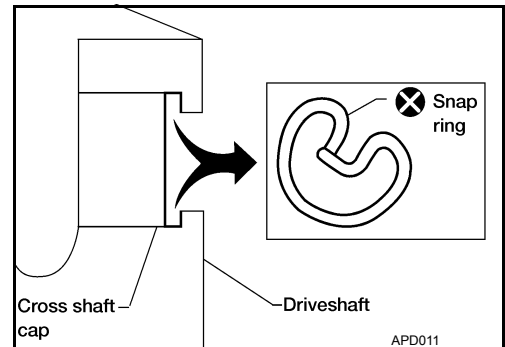

4. Push out and remove the journal bearing by lightly tapping the yoke with a hammer, taking care not to damage the journal or yoke hole.

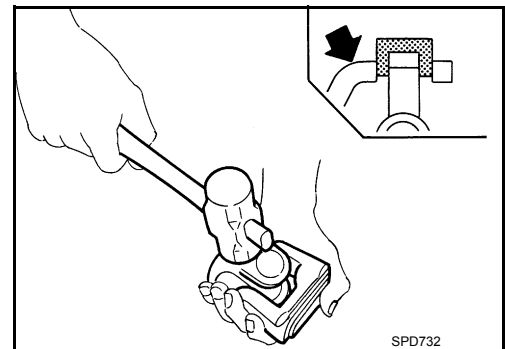

5. Remove the bearing at the opposite side of above operation.

NOTE:

Put marks on the disassembled parts so that they can be reinstalled in their original positions from which they were removed.

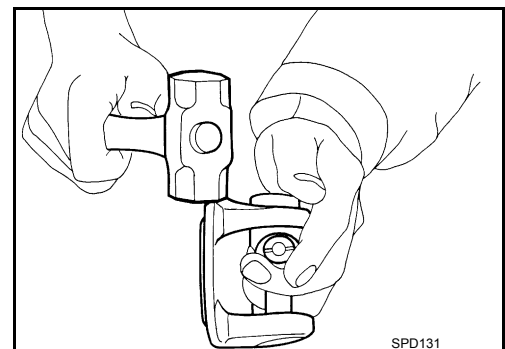

A
B
C
DLN
E
F
G
H
I
J
K
L
M
N
O
P

REAR PROPELLER SHAFT

< UNIT DISASSEMBLY AND ASSEMBLY >

[PROPELLER SHAFT: 3S1310]

Center Support Bearing

1. Remove the propeller shaft assembly from the vehicle. Refer to [DLN-155, "Removal and Installation"](#).
2. Put matching marks on the propeller shaft tube and the slip yoke.

CAUTION:

For matching marks, use paint. Do not damage the propeller shaft tube or slip yoke.

3. Remove and discard the clamp near the center support bearing, then slide the slip yoke off of propeller shaft tube.

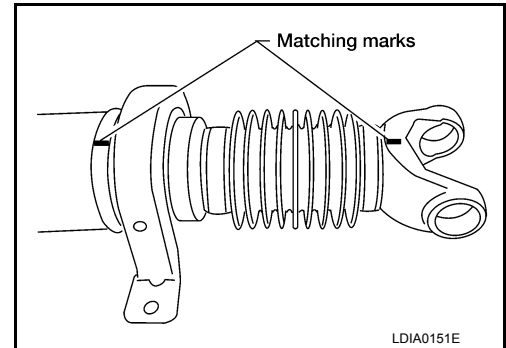

4. Press the center support bearing off the propeller shaft tube using Tool and suitable hydraulic press.

Tool number : 205-D002

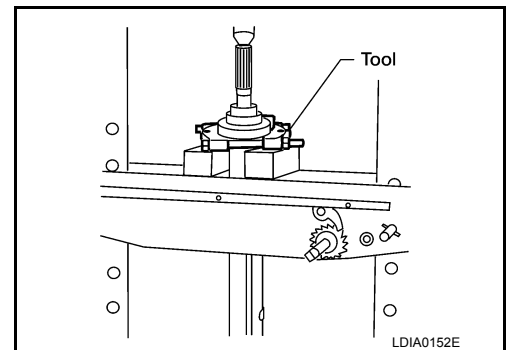

ASSEMBLY

Journal

1. Assemble the journal bearings. Apply multipurpose grease on the bearing inner surface.

NOTE:

During assembly, use caution so that the needle bearings do not fall down.

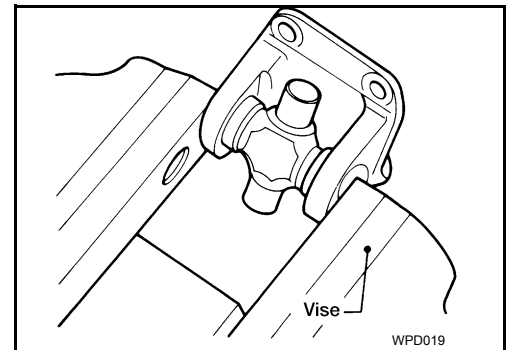

2. Select snap rings that will provide the specified play in an axial direction of the journal, and install them. Refer to [DLN-161, "Snap Ring"](#).

NOTE:

Select snap rings with a difference in thickness at both sides within 0.02 mm (0.0008 in).

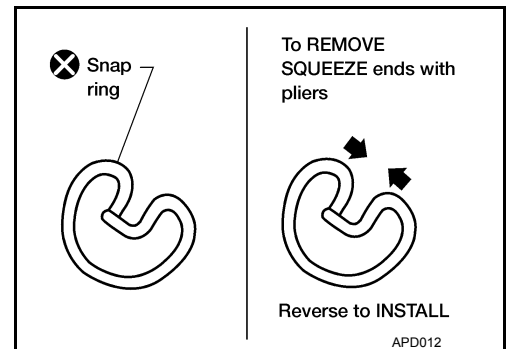

REAR PROPELLER SHAFT

< UNIT DISASSEMBLY AND ASSEMBLY >

[PROPELLER SHAFT: 3S1310]

3. Adjust the thrust clearance between the bearing and snap ring to zero by tapping the yoke.

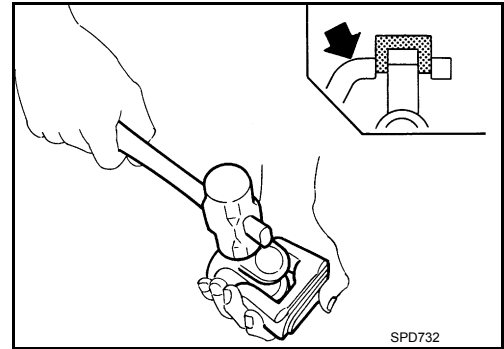

4. Make sure that the journal moves smoothly and is below the joint flex effort specification. Refer to [DLN-161, "General Specification"](#).

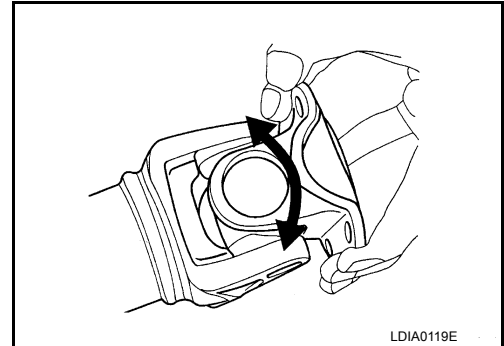

Center Support Bearing

1. Apply a thin coat of multi-purpose grease to both the propeller shaft tube and the inside surface of the center support bearing.
2. Install the center support bearing on the propeller shaft tube using a suitable pipe pressing on the inner race.

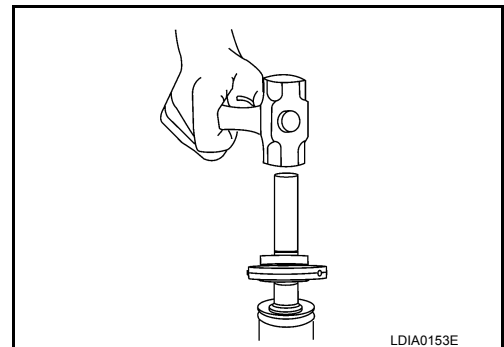

3. Install a new clamp over the boot on the slip yoke.
4. Align the matching marks and install the slip yoke on the propeller shaft tube.

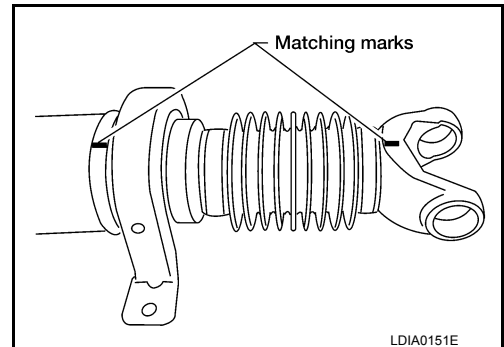

5. Clean the surfaces and position the boot over the propeller shaft tube and tighten the clamp.

A
B
C
DLN
E
F
G
H
I
J
K
L
M
N
O
P

REAR PROPELLER SHAFT

< UNIT DISASSEMBLY AND ASSEMBLY >

[PROPELLER SHAFT: 3S1310]

6. Install the center support bearing bracket, then install the rear propeller shaft assembly in the vehicle. Refer to [DLN-155](#), "[Removal and Installation](#)".

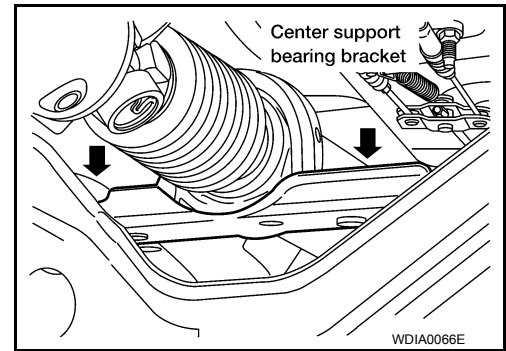

SERVICE DATA AND SPECIFICATIONS (SDS)

< SERVICE DATA AND SPECIFICATIONS (SDS)

[PROPELLER SHAFT: 3S1310]

SERVICE DATA AND SPECIFICATIONS (SDS)

SERVICE DATA AND SPECIFICATIONS (SDS)

General Specification

INFOID:000000007323968

Applied model	QR25DE
	2WD
	M/T A/T
Propeller shaft model	3S1310
Number of joints	3
Coupling method with rear final drive	Flange type
Coupling method with transmission	Sleeve type
1st Shaft length (Center bearing to spider)	741.5 ± 1.5 mm (29.19 ± 0.06 in)
2nd Shaft length (Spider to spider)	779.8 ± 1.5 mm (30.70 ± 0.06 in)
Shaft outer diameter	76.2 + 0.00/- 0.13 mm (3.00 +0.00/- 0.01 in)
Journal axial play	0.02 mm (0.0008 in) or less
Propeller shaft runout limit	0.6 mm (0.024 in) or less
Propeller shaft joint flex effort	2.26 N·m (0.23 kg-m, 20 in-lb) or less

Snap Ring

INFOID:000000007323969

Unit: mm (in)

Thickness	Color	Part Number*
1.99 (0.0783)	White	37146-C9400
2.02 (0.0795)	Yellow	37147-C9400
2.05 (0.0807)	Red	37148-C9400
2.08 (0.0819)	Green	37149-C9400
2.11 (0.0831)	Blue	37150-C9400
2.14 (0.0843)	Light brown	37151-C9400
2.17 (0.0854)	Black	37152-C9400
2.20 (0.0866)	No paint	37153-C9400

*: Always check with the Parts Department for the latest parts information.

PRECAUTION

PRECAUTIONS

Precaution for Supplemental Restraint System (SRS) "AIR BAG" and "SEAT BELT PRE-TENSIONER"

INFOID:000000007323970

The Supplemental Restraint System such as "AIR BAG" and "SEAT BELT PRE-TENSIONER", used along with a front seat belt, helps to reduce the risk or severity of injury to the driver and front passenger for certain types of collision. This system includes seat belt switch inputs and dual stage front air bag modules. The SRS system uses the seat belt switches to determine the front air bag deployment, and may only deploy one front air bag, depending on the severity of a collision and whether the front occupants are belted or unbelted. Information necessary to service the system safely is included in the SR and SB section of this Service Manual.

WARNING:

- To avoid rendering the SRS inoperative, which could increase the risk of personal injury or death in the event of a collision which would result in air bag inflation, all maintenance must be performed by an authorized NISSAN/INFINITI dealer.
- Improper maintenance, including incorrect removal and installation of the SRS, can lead to personal injury caused by unintentional activation of the system. For removal of Spiral Cable and Air Bag Module, see the SR section.
- Do not use electrical test equipment on any circuit related to the SRS unless instructed to in this Service Manual. SRS wiring harnesses can be identified by yellow and/or orange harnesses or harness connectors.

PRECAUTIONS WHEN USING POWER TOOLS (AIR OR ELECTRIC) AND HAMMERS

WARNING:

- When working near the Airbag Diagnosis Sensor Unit or other Airbag System sensors with the Ignition ON or engine running, DO NOT use air or electric power tools or strike near the sensor(s) with a hammer. Heavy vibration could activate the sensor(s) and deploy the air bag(s), possibly causing serious injury.
- When using air or electric power tools or hammers, always switch the Ignition OFF, disconnect the battery, and wait at least 3 minutes before performing any service.

PREPARATION

< PREPARATION >

[3S1330]

PREPARATION

PREPARATION

Special Service Tools

INFOID:000000007323971

Tool name	Description
205-D002 (—) Bearing splitter	Removing center support bearing assembly

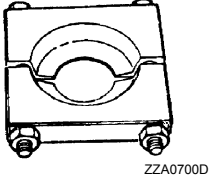

ZZA0700D

A

B

C

DLN

E

Commercial Service Tool

INFOID:000000007323972

Tool name	Description
Power tool	Loosening nuts, screws and bolts



PIIB1407E

F

G

H

I

J

K

L

M

N

O

P

NOISE, VIBRATION AND HARSHNESS (NVH) TROUBLESHOOTING

< SYSTEM DESCRIPTION >

[3S1330]

SYSTEM DESCRIPTION

NOISE, VIBRATION AND HARSHNESS (NVH) TROUBLESHOOTING

NVH Troubleshooting Chart

INFOID:000000007323973

Use the chart below to help you find the cause of the symptom. If necessary, repair or replace these parts.

Symptom	Possible cause and suspected parts											
	Uneven rotation torque	Rotation imbalance	Excessive run out	Differential	Axle	Suspension	Tires	Road wheel	Drive shaft	Brakes	Steering	
Noise	x	x	x	x	x	x	x	x	x	x	x	x
Shake					x	x	x	x	x	x		x
Vibration	x	x	x		x	x	x		x			x

x: Applicable

Reference page	DLN-165	DLN-165	DLN-172	DLN-221. "NVH Troubleshooting Chart" DLN-253. "NVH Troubleshooting Chart"	FAX-4. "NVH Troubleshooting Chart" RAX-5. "NVH Troubleshooting Chart"	FSU-5. "NVH Troubleshooting Chart" RSU-4. "NVH Troubleshooting Chart"	WT-43. "NVH Troubleshooting Chart"	WT-43. "NVH Troubleshooting Chart"	RAX-5. "NVH Troubleshooting Chart"	BR-5. "NVH Troubleshooting Chart"	ST-5. "NVH Troubleshooting Chart"
----------------	-------------------------	-------------------------	-------------------------	--	--	--	--	--	--	---	---

BASIC INSPECTION

PROPELLER SHAFT ASSEMBLY

Inspection

INFOID:000000007323974

APPEARANCE AND NOISE INSPECTION

Check the propeller shaft tube surface for dents or cracks. If damaged, replace the propeller shaft assembly.

PROPELLER SHAFT VIBRATION

If a vibration is present at high speed, inspect the propeller shaft runout first.

1. Measure the runout of the propeller shaft tube at several points by rotating the final drive companion flange with your hands.

Propeller shaft runout limit

2WD : Refer to [DLN-172, "General Specification"](#)

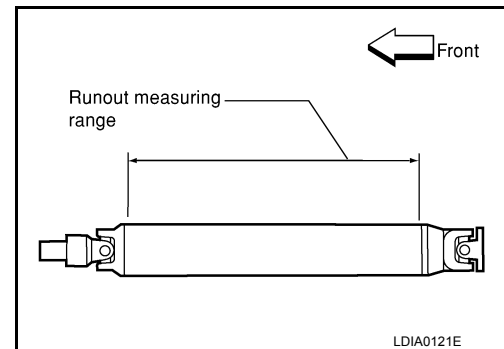
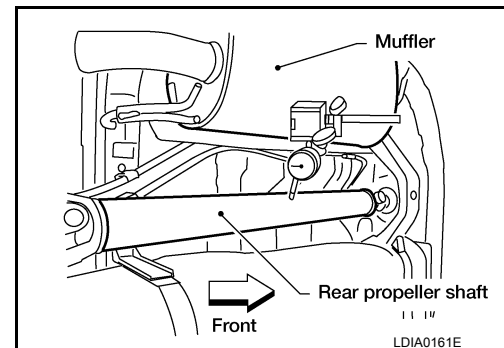

2. If the runout exceeds specifications, disconnect the propeller shaft at the final drive companion flange; then rotate the companion flange 90°, 180° and 270° and reconnect the propeller shaft.
3. Check the runout again. If the runout still exceeds specifications, replace the propeller shaft assembly.
4. After installation, check for vibration by driving vehicle.

REAR PROPELLER SHAFT

< UNIT REMOVAL AND INSTALLATION >

[3S1330]

UNIT REMOVAL AND INSTALLATION

REAR PROPELLER SHAFT

Removal and Installation

INFOID:000000007323975

COMPONENTS

Model 3S1330

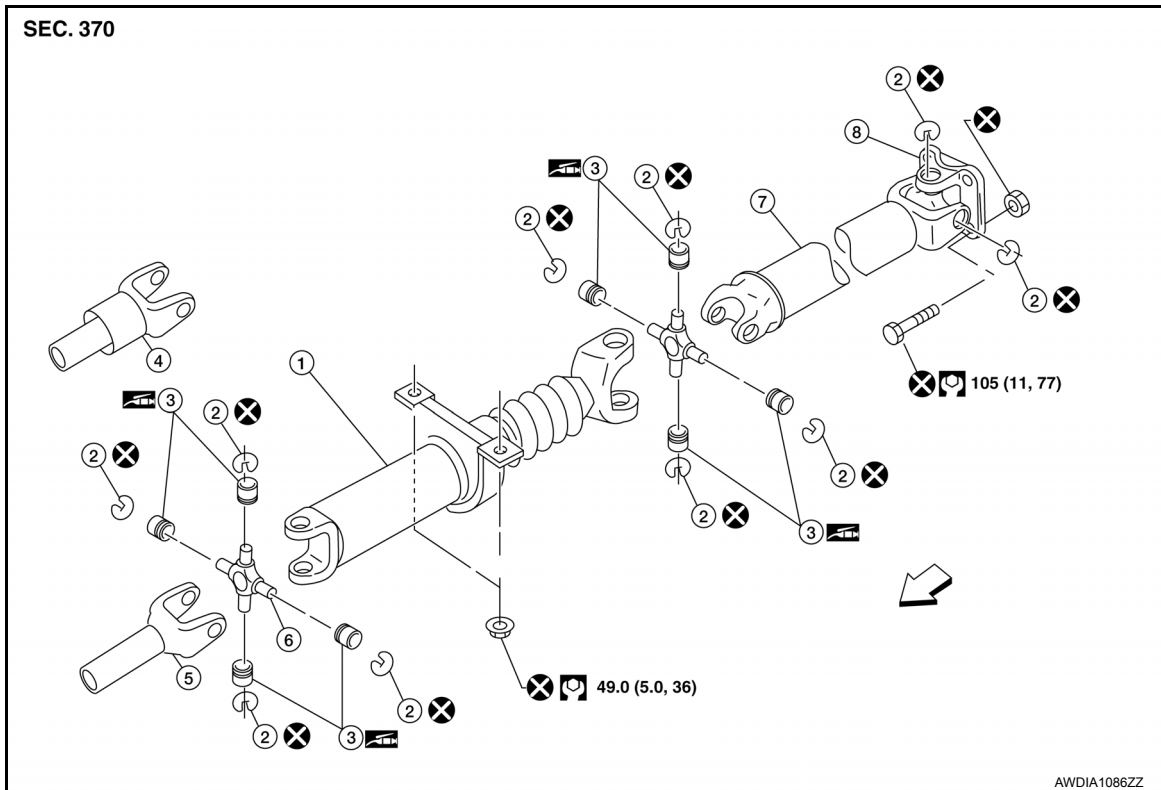

- | | | |
|--------------------------------|----------------------|--------------------------------|
| 1. Propeller shaft (1st shaft) | 2. Snap ring | 3. Journal bearing |
| 4. Sleeve yoke (A/T) | 5. Journal | 6. Propeller shaft (2nd shaft) |
| 7. Flange yoke | 8. Sleeve yoke (M/T) | ⇐ Front |

NOTE:

When removing components such as hoses, tubes/lines, etc., cap or plug openings to prevent fluid from spilling.

REMOVAL

1. Remove under cover (if equipped).
2. Put the transmission in neutral and release the parking brake.
3. Put matching marks on the rear propeller shaft flange yoke and the rear final drive companion flange as shown.

CAUTION:

For matching marks, use paint. Do not damage the rear propeller shaft flange yoke or the companion flange.

4. Remove the bolts, then remove the propeller shaft from the rear final drive and transmission.

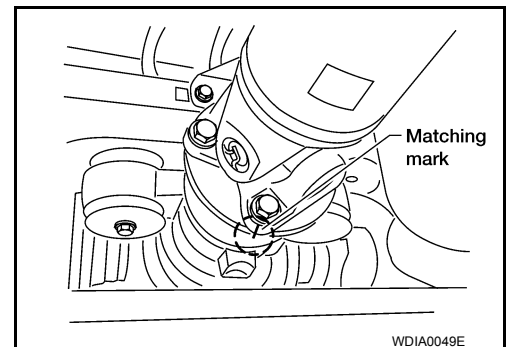

INSPECTION

REAR PROPELLER SHAFT

[3S1330]

< UNIT REMOVAL AND INSTALLATION >

- Inspect the propeller shaft runout. If runout exceeds the limit, replace the propeller shaft assembly.

Propeller shaft runout limit

2WD : Refer to [DLN-172, "General Specification"](#)

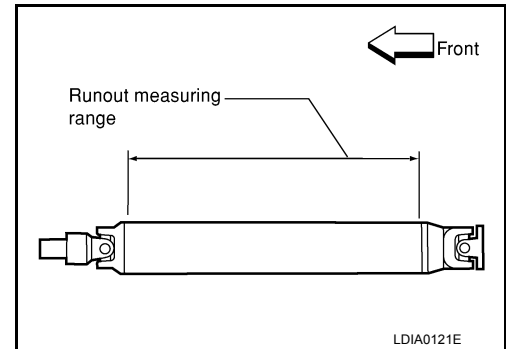

- While holding the flange yoke on one side, check axial play of the joint as shown. If the journal axial play exceeds the specification, repair or replace the journal parts.

Journal axial play : Refer to [DLN-172, "General Specification"](#)

- Check the propeller shaft for dents or cracks. If damage is detected, replace the propeller shaft assembly.

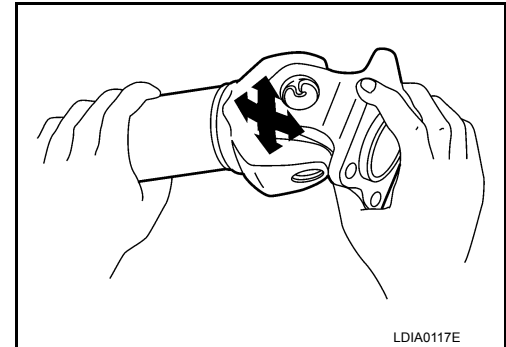

INSTALLATION

Installation is in the reverse order of removal.

- After installation, check for vibration by driving the vehicle. Refer to [DLN-164, "NVH Troubleshooting Chart"](#).

CAUTION:

Do not reuse the bolts and nuts. Always install new ones.

A
B
C
DLN
E
F
G
H
I
J
K
L
M
N
O
P

REAR PROPELLER SHAFT

< UNIT DISASSEMBLY AND ASSEMBLY >

[3S1330]

UNIT DISASSEMBLY AND ASSEMBLY

REAR PROPELLER SHAFT

Disassembly and Assembly

INFOID:000000007323976

DISASSEMBLY

Journal

1. Remove the propeller shaft assembly from the vehicle. Refer to [DLN-166. "Removal and Installation"](#).
2. Put matching marks on the rear propeller shaft tube and flange yoke as shown.

CAUTION:

For matching marks use paint. Do not damage the rear propeller shaft or flange yoke.

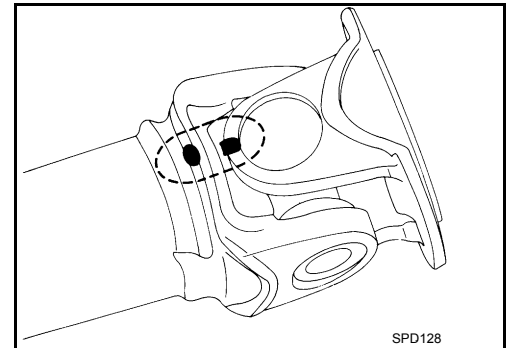

3. Remove the snap rings.

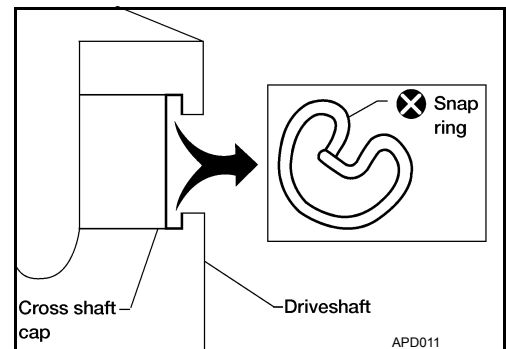

4. Push out and remove the journal bearing by lightly tapping the yoke with a hammer, taking care not to damage the journal or yoke hole.

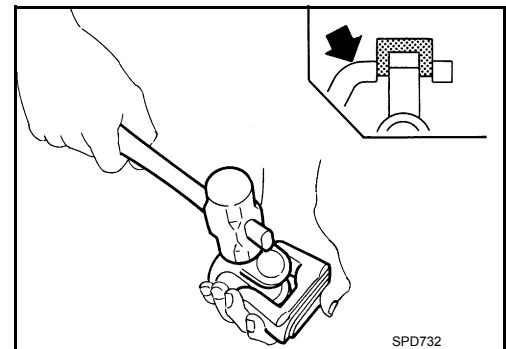

5. Remove the bearing at the opposite side of above operation.

NOTE:

Put marks on the disassembled parts so that they can be reinstalled in their original positions from which they were removed.

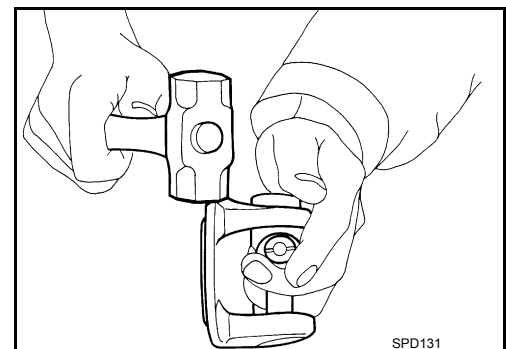

REAR PROPELLER SHAFT

< UNIT DISASSEMBLY AND ASSEMBLY >

[3S1330]

Center Support Bearing

1. Remove the propeller shaft assembly from the vehicle. Refer to [DLN-166, "Removal and Installation"](#).
2. Put matching marks on the propeller shaft tube and the slip yoke.

CAUTION:

For matching marks, use paint. Do not damage the propeller shaft tube or slip yoke.

3. Remove and discard the clamp near the center support bearing, then slide the slip yoke off of propeller shaft tube.

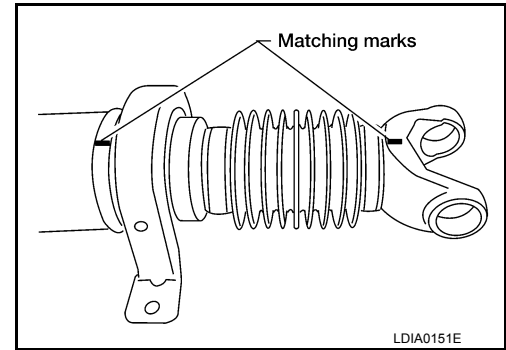

4. Press the center support bearing off the propeller shaft tube using Tool and suitable hydraulic press.

Tool number : 205-D002

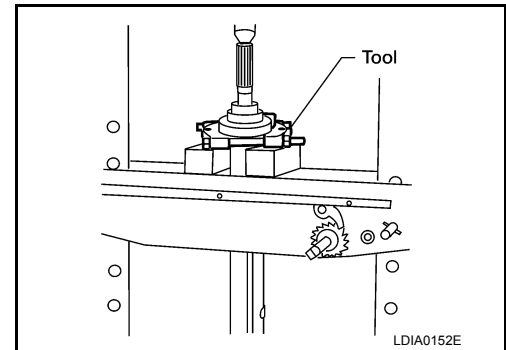

ASSEMBLY

Journal

1. Assemble the journal bearings. Apply multipurpose grease on the bearing inner surface.

NOTE:

During assembly, use caution so that the needle bearings do not fall down.

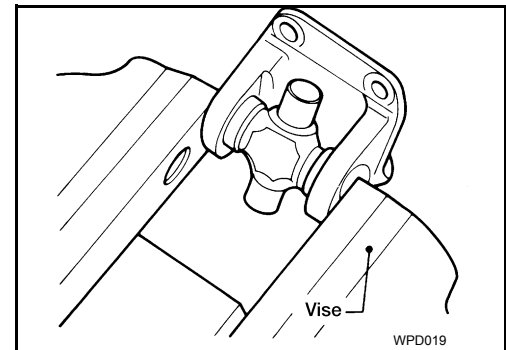

2. Select snap rings that will provide the specified play in an axial direction of the journal, and install them. Refer to [DLN-172, "Snap Ring"](#).

NOTE:

Select snap rings with a difference in thickness at both sides within 0.02 mm (0.0008 in).

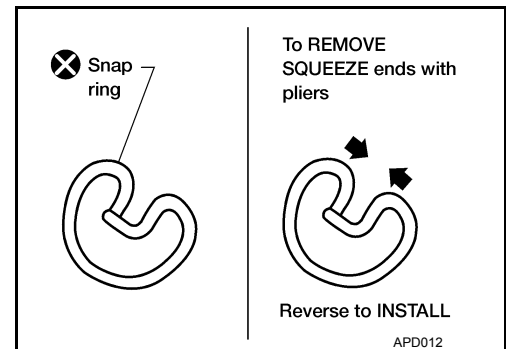

A
B
C
DLN
E
F
G
H
I
J
K
L
M
N
O
P

REAR PROPELLER SHAFT

< UNIT DISASSEMBLY AND ASSEMBLY >

[3S1330]

3. Adjust the thrust clearance between the bearing and snap ring to zero by tapping the yoke.

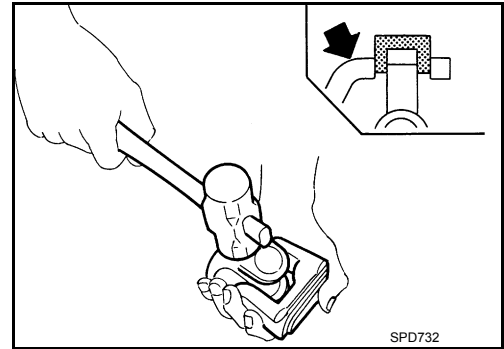

4. Make sure that the journal moves smoothly and is below the joint flex effort specification. Refer to [DLN-172, "General Specification"](#).

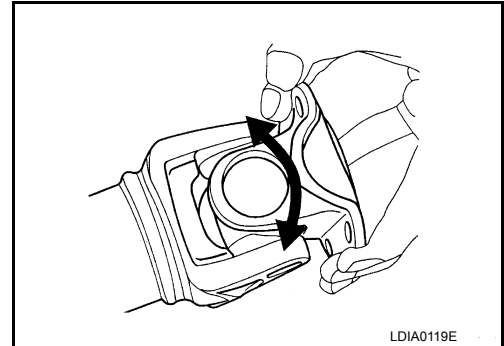

Center Support Bearing

1. Apply a thin coat of multi-purpose grease to both the propeller shaft tube and the inside surface of the center support bearing.
2. Install the center support bearing on the propeller shaft tube using a suitable pipe pressing on the inner race.

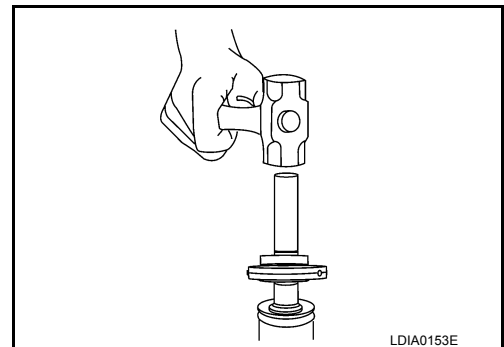

3. Install a new clamp over the boot on the slip yoke.
4. Align the matching marks and install the slip yoke on the propeller shaft tube.

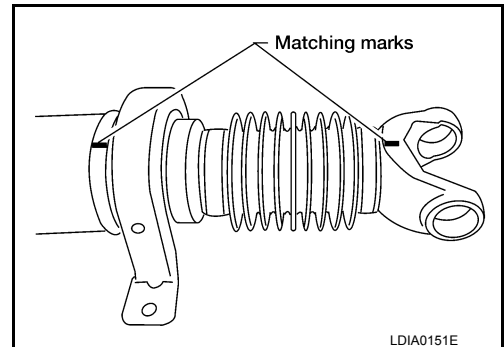

5. Clean the surfaces and position the boot over the propeller shaft tube and tighten the clamp.

REAR PROPELLER SHAFT

< UNIT DISASSEMBLY AND ASSEMBLY >

[3S1330]

6. Install the center support bearing bracket, then install the rear propeller shaft assembly in the vehicle. Refer to [DLN-166](#), "[Removal and Installation](#)".

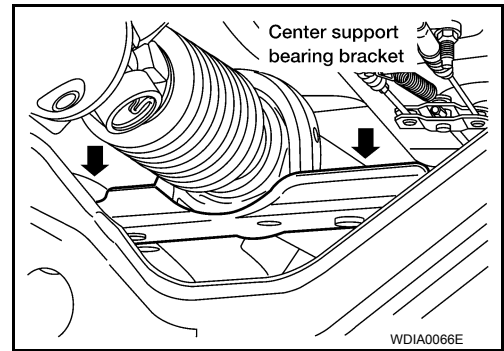

A
B
C

DLN

E
F
G
H
I
J
K
L
M
N
O
P

SERVICE DATA AND SPECIFICATIONS (SDS)

< SERVICE DATA AND SPECIFICATIONS (SDS)

[3S1330]

SERVICE DATA AND SPECIFICATIONS (SDS)

SERVICE DATA AND SPECIFICATIONS (SDS)

General Specification

INFOID:000000007323977

Applied model	VQ40DE		
	2WD		
	M/T short bed	M/T long bed	A/T long bed
Propeller shaft model	3S1330		
Number of joints	3		
Coupling method with rear final drive	Flange type		
Coupling method with transmission	Sleeve type		
1st Shaft length (Center bearing to spider)	674.5 ± 1.5 mm (26.56 ± 0.06 in)	674.5 ± 1.5 mm (26.56 ± 0.06 in)	741.5 ± 1.5 mm (29.19 ± 0.06 in)
2nd Shaft length (Spider to spider)	783.8 ± 1.5 mm (30.86 ± 0.06 in)	1138.8 ± 1.5 mm (44.83 ± 0.06 in)	1152.8 ± 1.5 mm (45.39 ± 0.06 in)
Shaft outer diameter	76.2 + 0.00/ - 0.13 mm (3.00 + 0.00/ - 0.01 in)		
Journal axial play	0.02 mm (0.0008 in) or less		
Propeller shaft runout limit	0.6 mm (0.024 in) or less		
Propeller shaft joint flex effort	2.26 N·m (0.23 kg·m, 20 in·lb) or less		

Snap Ring

INFOID:000000007323978

Unit: mm (in)

Thickness	Color	Part Number*
1.99 (0.0783)	White	37146-C9400
2.02 (0.0795)	Yellow	37147-C9400
2.05 (0.0807)	Red	37148-C9400
2.08 (0.0819)	Green	37149-C9400
2.11 (0.0831)	Blue	37150-C9400
2.14 (0.0843)	Light brown	37151-C9400
2.17 (0.0854)	Black	37152-C9400
2.20 (0.0866)	No paint	37153-C9400

*: Always check with the Parts Department for the latest parts information.

PRECAUTION

PRECAUTIONS

Precaution for Supplemental Restraint System (SRS) "AIR BAG" and "SEAT BELT PRE-TENSIONER"

INFOID:000000007323979

The Supplemental Restraint System such as "AIR BAG" and "SEAT BELT PRE-TENSIONER", used along with a front seat belt, helps to reduce the risk or severity of injury to the driver and front passenger for certain types of collision. This system includes seat belt switch inputs and dual stage front air bag modules. The SRS system uses the seat belt switches to determine the front air bag deployment, and may only deploy one front air bag, depending on the severity of a collision and whether the front occupants are belted or unbelted. Information necessary to service the system safely is included in the SR and SB section of this Service Manual.

WARNING:

- To avoid rendering the SRS inoperative, which could increase the risk of personal injury or death in the event of a collision which would result in air bag inflation, all maintenance must be performed by an authorized NISSAN/INFINITI dealer.
- Improper maintenance, including incorrect removal and installation of the SRS, can lead to personal injury caused by unintentional activation of the system. For removal of Spiral Cable and Air Bag Module, see the SR section.
- Do not use electrical test equipment on any circuit related to the SRS unless instructed to in this Service Manual. SRS wiring harnesses can be identified by yellow and/or orange harnesses or harness connectors.

PRECAUTIONS WHEN USING POWER TOOLS (AIR OR ELECTRIC) AND HAMMERS

WARNING:

- When working near the Airbag Diagnosis Sensor Unit or other Airbag System sensors with the Ignition ON or engine running, DO NOT use air or electric power tools or strike near the sensor(s) with a hammer. Heavy vibration could activate the sensor(s) and deploy the air bag(s), possibly causing serious injury.
- When using air or electric power tools or hammers, always switch the Ignition OFF, disconnect the battery, and wait at least 3 minutes before performing any service.

A
B
C
DLN
E
F
G
H
I
J
K
L
M
N
O
P

PREPARATION

< PREPARATION >

[PROPELLER SHAFT: 3S1330-2BJ100]

PREPARATION

PREPARATION

Special Service Tools

INFOID:000000007323980

Tool name	Description
205-D002 (—) Bearing splitter	Removing center support bearing assembly

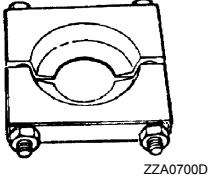

Commercial Service Tool

INFOID:000000007323981

Tool name	Description
Power tool	Loosening nuts, screws and bolts



NOISE, VIBRATION AND HARSHNESS (NVH) TROUBLESHOOTING

< SYSTEM DESCRIPTION >

[PROPELLER SHAFT: 3S1330-2BJ100]

SYSTEM DESCRIPTION

NOISE, VIBRATION AND HARSHNESS (NVH) TROUBLESHOOTING

NVH Troubleshooting Chart

INFOID:000000007323982

Use the chart below to help you find the cause of the symptom. If necessary, repair or replace these parts.

Symptom	Possible cause and suspected parts											
	Uneven rotation torque	Rotation imbalance	Excessive run out	Differential	Axle	Suspension	Tires	Road wheel	Drive shaft	Brakes	Steering	
Noise	x	x	x	x	x	x	x	x	x	x	x	x
Shake					x	x	x	x	x	x		x
Vibration	x	x	x		x	x	x		x			x

x: Applicable

Reference page	Possible cause and suspected parts											
	Uneven rotation torque	Rotation imbalance	Excessive run out	Differential	Axle	Suspension	Tires	Road wheel	Drive shaft	Brakes	Steering	
	DLN-135 (front) DLN-175 (rear)	DLN-135 (front) DLN-175 (rear)	DLN-135 (front) DLN-153 (rear)	DLN-187, "NVH Troubleshooting Chart" DLN-221, "NVH Troubleshooting Chart"	FAX-4, "NVH Troubleshooting Chart" RAX-5, "NVH Troubleshooting Chart"	FSU-5, "NVH Troubleshooting Chart" RSU-4, "NVH Troubleshooting Chart"	WT-43, "NVH Troubleshooting Chart"	WT-43, "NVH Troubleshooting Chart"	FAX-4, "NVH Troubleshooting Chart"	BR-5, "NVH Troubleshooting Chart"	ST-5, "NVH Troubleshooting Chart"	

A
B
C
DLN
E
F
G
H
I
J
K
L
M
N
O
P

PROPELLER SHAFT ASSEMBLY

< BASIC INSPECTION >

[PROPELLER SHAFT: 3S1330-2BJ100]

BASIC INSPECTION

PROPELLER SHAFT ASSEMBLY

Inspection

INFOID:000000007323983

APPEARANCE AND NOISE INSPECTION

Check the propeller shaft tube surface for dents or cracks. If damaged, replace the propeller shaft assembly.

PROPELLER SHAFT VIBRATION

If a vibration is present at high speed, inspect the propeller shaft runout first.

1. Measure the runout of the propeller shaft tube at several points by rotating the final drive companion flange with your hands.

Propeller shaft runout limit

2WD : Refer to [DLN-182, "General Specification"](#)

4WD : Refer to [DLN-182, "General Specification"](#)

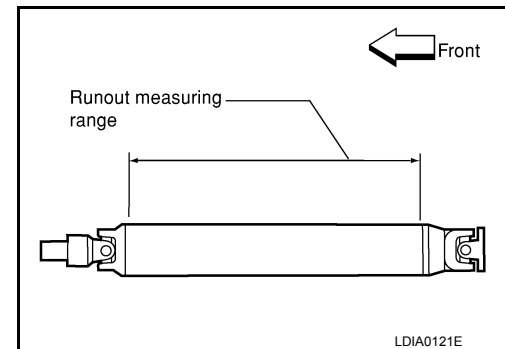
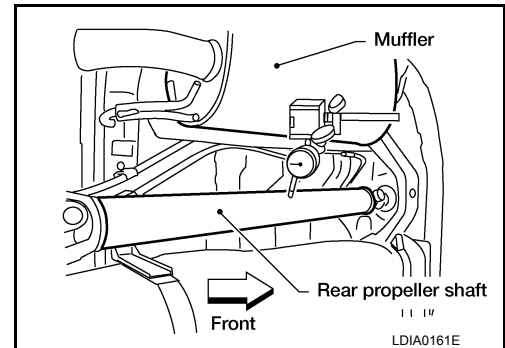

2. If the runout exceeds specifications, disconnect the propeller shaft at the final drive companion flange; then rotate the companion flange 90°, 180° and 270° and reconnect the propeller shaft.
3. Check the runout again. If the runout still exceeds specifications, replace the propeller shaft assembly.
4. After installation, check for vibration by driving vehicle.

REAR PROPELLER SHAFT

< UNIT REMOVAL AND INSTALLATION >

[PROPELLER SHAFT: 3S1330-2BJ100]

UNIT REMOVAL AND INSTALLATION

REAR PROPELLER SHAFT

Removal and Installation

INFOID:000000007323984

COMPONENTS

Model 3S1330-2BJ100

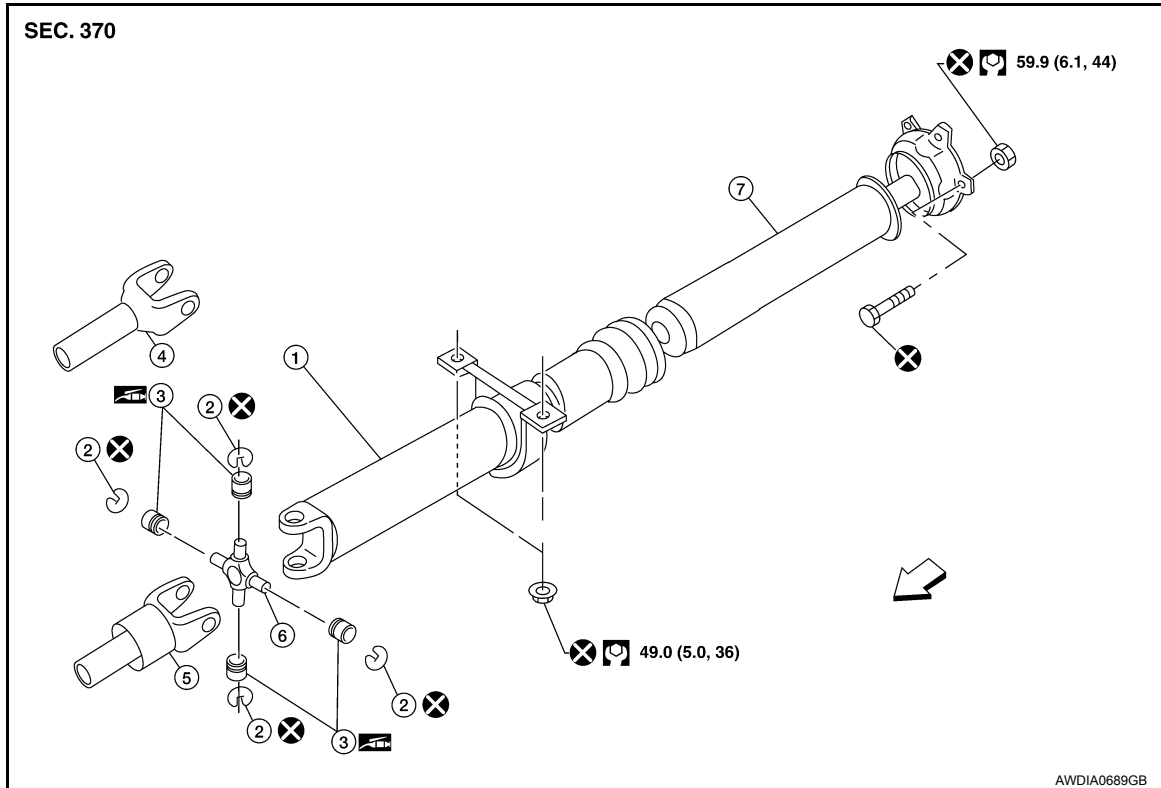

- | | | |
|--------------------------------|----------------------|--------------------|
| 1. Propeller shaft (1st shaft) | 2. Snap ring | 3. Journal bearing |
| 4. Sleeve yoke (4WD) | 5. Sleeve yoke (2WD) | 6. Journal |
| 7. Propeller shaft (2nd shaft) | ← Front | |

NOTE:

When removing components such as hoses, tubes/lines, etc., cap or plug openings to prevent fluid from spilling.

REMOVAL

1. Remove under cover (if equipped).
2. Put the transmission in neutral and release the parking brake.
3. Put matching marks on the rear propeller shaft flange yoke and the rear final drive companion flange as shown.

CAUTION:

For matching marks, use paint. Do not damage the rear propeller shaft flange yoke or the companion flange.

4. Remove the bolts, then remove the propeller shaft from the rear final drive and transmission or transfer.

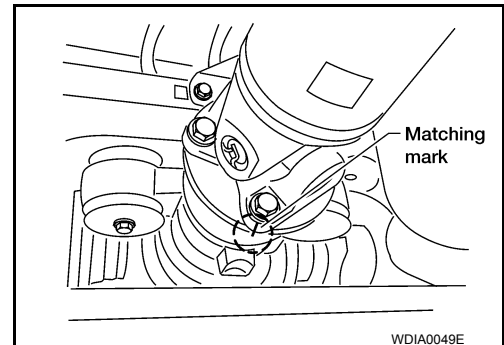

INSPECTION

REAR PROPELLER SHAFT

< UNIT REMOVAL AND INSTALLATION >

[PROPELLER SHAFT: 3S1330-2BJ100]

- Inspect the propeller shaft runout. If runout exceeds the limit, replace the propeller shaft assembly.

Propeller shaft runout limit

2WD : Refer to [DLN-182, "General Specification"](#)

4WD : Refer to [DLN-182, "General Specification"](#)

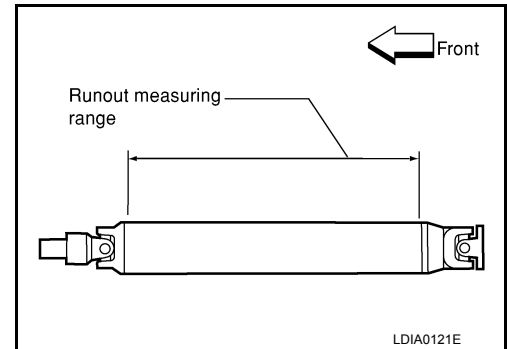

- While holding the flange yoke on one side, check axial play of the joint as shown. If the journal axial play exceeds the specification, repair or replace the journal parts.

Journal axial play : Refer to [DLN-182, "General Specification"](#)

- Check the propeller shaft for dents or cracks. If damage is detected, replace the propeller shaft assembly.

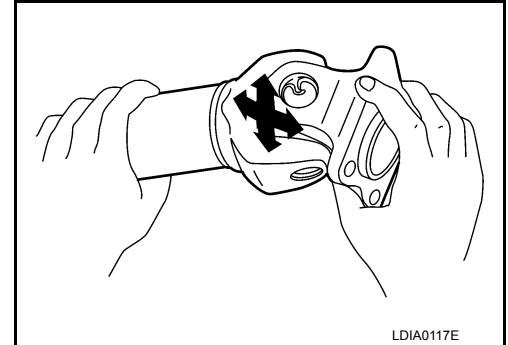

INSTALLATION

Installation is in the reverse order of removal.

- After installation, check for vibration by driving the vehicle. Refer to [DLN-175, "NVH Troubleshooting Chart"](#).

CAUTION:

Do not reuse the bolts and nuts. Always install new ones.

REAR PROPELLER SHAFT

< UNIT DISASSEMBLY AND ASSEMBLY >

[PROPELLER SHAFT: 3S1330-2BJ100]

UNIT DISASSEMBLY AND ASSEMBLY

REAR PROPELLER SHAFT

Disassembly and Assembly

INFOID:000000007323985

DISASSEMBLY

Journal

1. Remove the propeller shaft assembly from the vehicle. Refer to [DLN-177. "Removal and Installation"](#).
2. Put matching marks on the rear propeller shaft tube and flange yoke as shown.

CAUTION:

For matching marks use paint. Do not damage the rear propeller shaft or flange yoke.

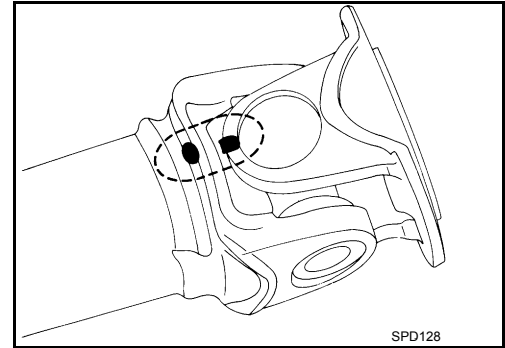

3. Remove the snap rings.

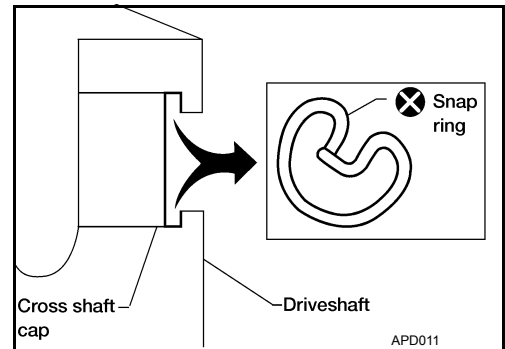

4. Push out and remove the journal bearing by lightly tapping the yoke with a hammer, taking care not to damage the journal or yoke hole.

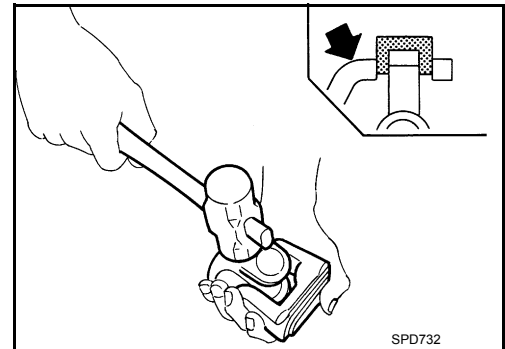

5. Remove the bearing at the opposite side of above operation.

NOTE:

Put marks on the disassembled parts so that they can be reinstalled in their original positions from which they were removed.

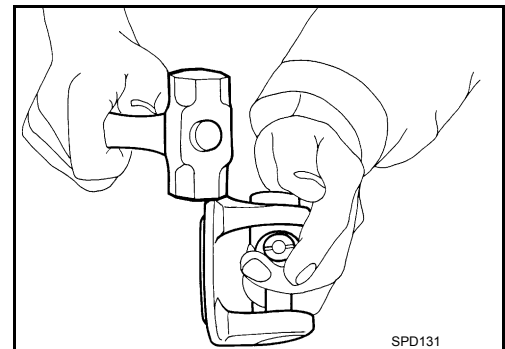

A
B
C
DLN
E
F
G
H
I
J
K
L
M
N
O
P

REAR PROPELLER SHAFT

< UNIT DISASSEMBLY AND ASSEMBLY >

[PROPELLER SHAFT: 3S1330-2BJ100]

Center Support Bearing

1. Remove the propeller shaft assembly from the vehicle. Refer to [DLN-177, "Removal and Installation"](#).
2. Put matching marks on the propeller shaft tube and the slip yoke.

CAUTION:

For matching marks, use paint. Do not damage the propeller shaft tube or slip yoke.

3. Remove and discard the clamp near the center support bearing, then slide the slip yoke off of propeller shaft tube.
4. Press the center support bearing off the propeller shaft tube using Tool and suitable hydraulic press.

Tool number : 205-D002

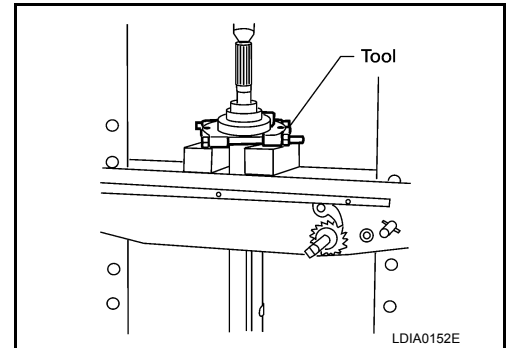

ASSEMBLY

Journal

1. Assemble the journal bearings. Apply multipurpose grease on the bearing inner surface.

NOTE:

During assembly, use caution so that the needle bearings do not fall down.

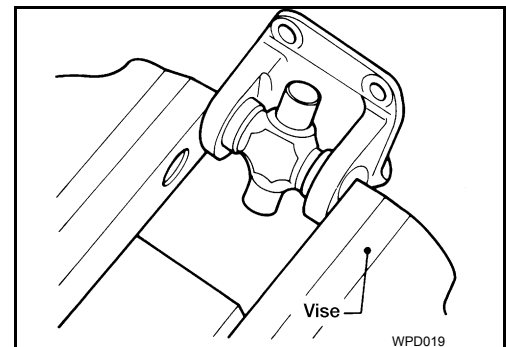

2. Select snap rings that will provide the specified play in an axial direction of the journal, and install them. Refer to [DLN-182, "Snap Ring"](#).

NOTE:

Select snap rings with a difference in thickness at both sides within 0.02 mm (0.0008 in).

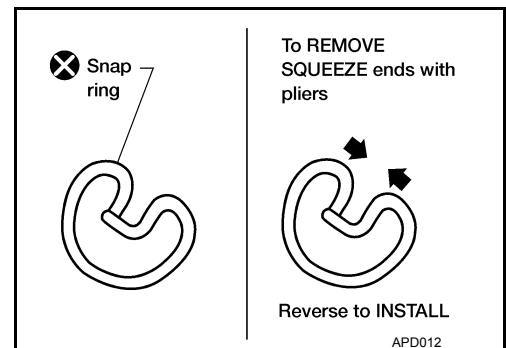

3. Adjust the thrust clearance between the bearing and snap ring to zero by tapping the yoke.

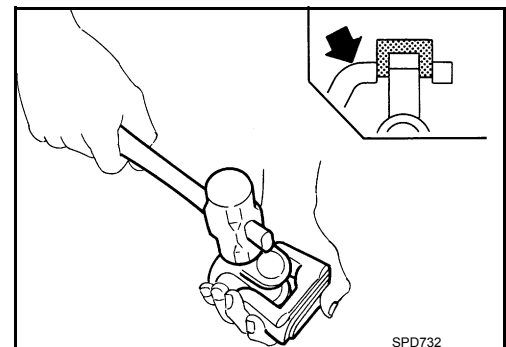

REAR PROPELLER SHAFT

< UNIT DISASSEMBLY AND ASSEMBLY >

[PROPELLER SHAFT: 3S1330-2BJ100]

4. Make sure that the journal moves smoothly and is below the joint flex effort specification. Refer to [DLN-182, "General Specification"](#).

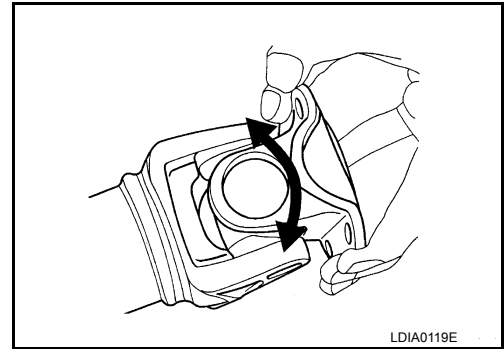

A
B
C

DLN

Center Support Bearing

1. Apply a thin coat of multi-purpose grease to both the propeller shaft tube and the inside surface of the center support bearing.
2. Install the center support bearing on the propeller shaft tube using a suitable pipe pressing on the inner race.

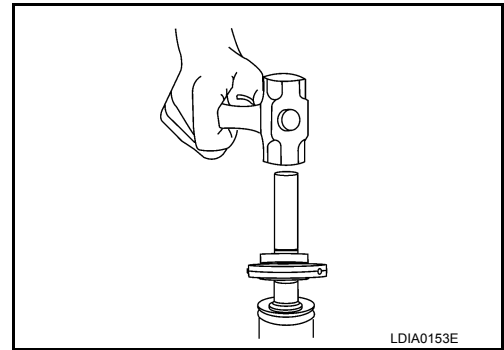

E
F
G
H

3. Install a new clamp over the boot on the slip yoke.
4. Align the matching marks and install the slip yoke on the propeller shaft tube.
5. Clean the surfaces and position the boot over the propeller shaft tube and tighten the clamp.
6. Install the center support bearing bracket, then install the rear propeller shaft assembly in the vehicle. Refer to [DLN-177, "Removal and Installation"](#).

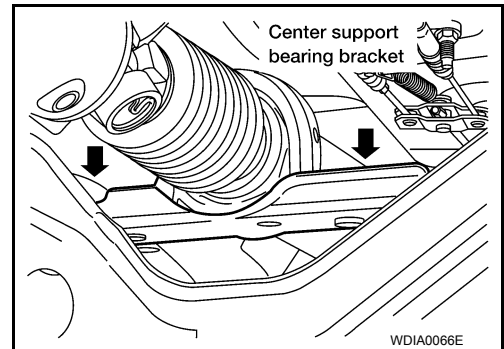

I
J
K
L
M
N
O
P

SERVICE DATA AND SPECIFICATIONS (SDS)

< SERVICE DATA AND SPECIFICATIONS (SDS)

[PROPELLER SHAFT: 3S1330-2BJ100]

SERVICE DATA AND SPECIFICATIONS (SDS)

SERVICE DATA AND SPECIFICATIONS (SDS)

General Specification

INFOID:000000007323986

Applied model	Long bed 4WD		Short bed 2WD
	VQ40DE		
	M/T	A/T	A/T
Propeller shaft model	3S1330-2BJ100		
Number of joints	3		
Coupling method with rear final drive	Flange type		
Coupling method with transmission	Sleeve type		
1st Shaft length (Center bearing to spider)	625.5 ± 1.5 mm (24.63 ± 0.06 in)	625.5 ± 1.5 mm (24.63 ± 0.06 in)	741.5 ± 1.5 mm (29.19 ± 0.06 in)
2nd Shaft length (CV joint to flange mount surface)	783.6 ± 1.5 mm (30.85 ± 0.06 in)	813.6 ± 1.5 mm (32.03 ± 0.06 in)	813.6 ± 1.5 mm (32.03 ± 0.06 in) [783.6 ± 1.5 mm (30.85 ± 0.06 in)]*
Shaft outer diameter	76.2 +0.00/ - 0.13 mm (3.00 + 0.00/ - 0.01 in)		
Journal axial play	0.02 mm (0.0008 in) or less		
Propeller shaft runout limit	0.6 mm (0.024 in) or less		
Propeller shaft joint flex effort	2.26 N·m (0.23 kg-m, 20 in-lb) or less		

*Off-Road

Snap Ring

INFOID:000000007323987

Model 3S1330-2B100

Unit: mm (in)

Thickness	Color	Part Number*
1.99 (0.0783)	White	37146-C9400
2.02 (0.0795)	Yellow	37147-C9400
2.05 (0.0807)	Red	37148-C9400
2.08 (0.0819)	Green	37149-C9400
2.11 (0.0831)	Blue	37150-C9400
2.14 (0.0843)	Light brown	37151-C9400
2.17 (0.0854)	Black	37152-C9400
2.20 (0.0866)	No paint	37153-C9400

*: Always check with the Parts Department for the latest parts information.

PRECAUTION

PRECAUTIONS

Precaution for Supplemental Restraint System (SRS) "AIR BAG" and "SEAT BELT PRE-TENSIONER"

INFOID:000000007323988

The Supplemental Restraint System such as "AIR BAG" and "SEAT BELT PRE-TENSIONER", used along with a front seat belt, helps to reduce the risk or severity of injury to the driver and front passenger for certain types of collision. This system includes seat belt switch inputs and dual stage front air bag modules. The SRS system uses the seat belt switches to determine the front air bag deployment, and may only deploy one front air bag, depending on the severity of a collision and whether the front occupants are belted or unbelted. Information necessary to service the system safely is included in the SR and SB section of this Service Manual.

WARNING:

- To avoid rendering the SRS inoperative, which could increase the risk of personal injury or death in the event of a collision which would result in air bag inflation, all maintenance must be performed by an authorized NISSAN/INFINITI dealer.
- Improper maintenance, including incorrect removal and installation of the SRS, can lead to personal injury caused by unintentional activation of the system. For removal of Spiral Cable and Air Bag Module, see the SR section.
- Do not use electrical test equipment on any circuit related to the SRS unless instructed to in this Service Manual. SRS wiring harnesses can be identified by yellow and/or orange harnesses or harness connectors.

PRECAUTIONS WHEN USING POWER TOOLS (AIR OR ELECTRIC) AND HAMMERS

WARNING:

- When working near the Airbag Diagnosis Sensor Unit or other Airbag System sensors with the Ignition ON or engine running, DO NOT use air or electric power tools or strike near the sensor(s) with a hammer. Heavy vibration could activate the sensor(s) and deploy the air bag(s), possibly causing serious injury.
- When using air or electric power tools or hammers, always switch the Ignition OFF, disconnect the battery, and wait at least 3 minutes before performing any service.

Precaution for Servicing Front Final Drive

INFOID:000000007323989

- Before starting diagnosis of the vehicle, understand the symptoms well. Perform correct and systematic operations.
- Check for the correct installation status prior to removal or disassembly. When matching marks are required, be certain they do not interfere with the function of the parts they are applied to.
- Overhaul should be done in a clean work area, a dust proof area is recommended.
- Before disassembly, completely remove sand and mud from the exterior of the unit, preventing them from entering into the unit during disassembly or assembly.
- Always use shop paper for cleaning the inside of components.
- Avoid using cotton gloves or a shop cloth to prevent the entering of lint.
- Check appearance of the disassembled parts for damage, deformation, and abnormal wear. Replace them with new ones if necessary.
- Gaskets, seals and O-rings should be replaced any time the unit is disassembled.
- Clean and flush the parts sufficiently and blow them dry.
- Be careful not to damage sliding surfaces and mating surfaces.
- When applying sealant, remove the old sealant from the mating surface; then remove any moisture, oil, and foreign materials from the application and mating surfaces.
- In principle, tighten nuts or bolts gradually in several steps working diagonally from inside to outside. If a tightening sequence is specified, observe it.
- During assembly, observe the specified tightening torque.
- Add new differential gear oil, petroleum jelly, or multi-purpose grease, as specified.

A
B
C
DLN
E
F
G
H
I
J
K
L
M
N
O
P

PREPARATION

< PREPARATION >

[FRONT FINAL DRIVE: R180A]

PREPARATION

PREPARATION

Special Service Tool

INFOID:000000007323990

The actual shapes of Kent-Moore tools may differ from those of special service tools illustrated here.

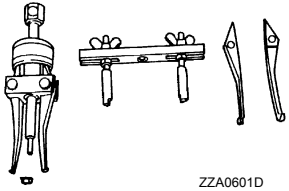
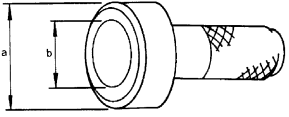
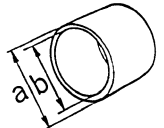
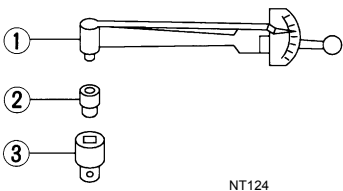
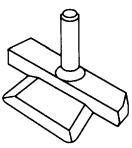
Tool number (Kent-Moore No.) Tool name	Description
ST33290001 (J-34286) Puller  <p style="text-align: center;">ZZA0601D</p>	Removing front oil seal
ST30720000 (J-25405) Drift  <p style="text-align: center;">ZZA0811D</p>	<ul style="list-style-type: none"> • Installing front oil seal • Installing side oil seal <p>a: 77 mm (3.03 in) dia. b: 55.5 mm (2.185 in) dia.</p>
ST27863000 (—) Drift  <p style="text-align: center;">ZZA1003D</p>	<ul style="list-style-type: none"> • Installing front oil seal • Installing side oil seal <p>a: 74.5 mm (2.933 in) dia. b: 62.5 mm (2.461 in) dia.</p>
ST3127S000 (J-25765-A) Preload gauge 1: GG91030000 (J-25765) Torque wrench 2: HT62940000 (—) Socket adapter (1/2") 3: HT62900000 (—) Socket adapter (3/8")  <p style="text-align: center;">NT124</p>	Measuring drive pinion bearing preload torque and total preload torque
KV10111100 (J-37228) Seal cutter  <p style="text-align: center;">S-NT046</p>	Removing carrier cover

PREPARATION

< PREPARATION >

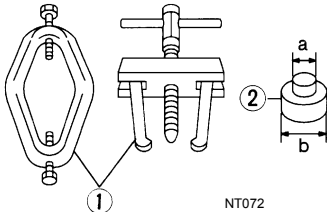
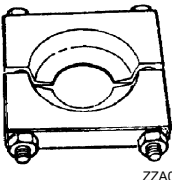
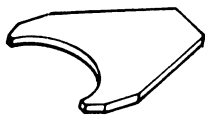
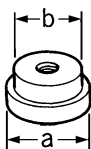
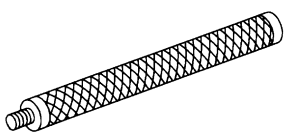
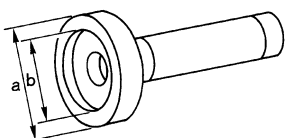
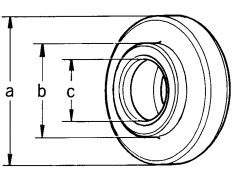

[FRONT FINAL DRIVE: R180A]

Tool number (Kent-Moore No.) Tool name	Description	
ST3306S001 (—) Differential side bearing puller set 1: ST33051001 (J-22888-20) Puller 2: ST33061000 (J-8107-2) Base		A B C <div style="background-color: black; color: white; padding: 2px; text-align: center;">DLN</div>
ST30031000 (J-22912-01) Replacer		E F
KV38100600 (J-25267) Drift		G H
ST30613000 (J-25742-3) Drift		I J K
ST30611000 (J-25742-1) Drift bar		L M
KV38100200 (J-26233) Drift		N O
ST30901000 (J-26010-01) Drift		P

PREPARATION

< PREPARATION >

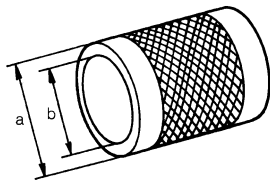
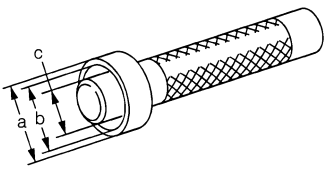
[FRONT FINAL DRIVE: R180A]

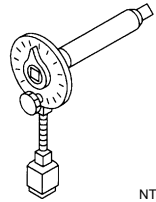
Tool number (Kent-Moore No.) Tool name		Description
ST33200000 (J-26082) Drift	 <p style="text-align: center; font-size: small;">ZZA1002D</p>	Installing drive pinion front bearing inner race a: 60 mm (2.36 in) dia. b: 44.5 mm (1.752 in) dia.
ST33230000 (J-35867) Drift	 <p style="text-align: center; font-size: small;">ZZA1046D</p>	Installing side bearing inner race a: 51 mm (2.01 in) dia. b: 41 mm (1.61 in) dia. c: 28 mm (1.10 in) dia.
— (J-34309) Differential shim selector tool	 <p style="text-align: center; font-size: small;">NT134</p>	Adjusting bearing preload and drive pinion height
— (J-25269-18) Side bearing disc (2 Req'd)	 <p style="text-align: center; font-size: small;">NT135</p>	Selecting drive pinion height adjusting washer
KV10112100 (BT-8653-A) Angle wrench	 <p style="text-align: center; font-size: small;">NT014</p>	Tightening bolts for drive gear

Commercial Service Tool

INFOID:000000007323991

Tool name		Description
Power tool	 <p style="text-align: center; font-size: x-small;">PIIB1407E</p>	Loosening nuts, screws and bolts

NOISE, VIBRATION AND HARSHNESS (NVH) TROUBLESHOOTING

< SYSTEM DESCRIPTION >

[FRONT FINAL DRIVE: R180A]

SYSTEM DESCRIPTION

NOISE, VIBRATION AND HARSHNESS (NVH) TROUBLESHOOTING

NVH Troubleshooting Chart

INFOID:000000007323992

Use the chart below to help you find the cause of the symptom. If necessary, repair or replace these parts.

Symptom	Noise															
		x	x	x	x	x	x	x	x	x	x	x	x	x	x	x
Reference page		DLN-196	DLN-196	DLN-196	DLN-196	DLN-196	DLN-189	DLN-135. "NVH Troubleshooting Chart"	FAX-4. "NVH Troubleshooting Chart"	FSU-5. "NVH Troubleshooting Chart"	WT-43. "NVH Troubleshooting Chart"	WT-43. "NVH Troubleshooting Chart"	FAX-4. "NVH Troubleshooting Chart"	BR-5. "NVH Troubleshooting Chart"	ST-5. "NVH Troubleshooting Chart"	
Possible cause and SUSPECTED PARTS		Gear tooth rough	Gear contact improper	Tooth surfaces worn	Backlash incorrect	Companion flange excessive runout	Gear oil improper	PROPELLER SHAFT	FRONT AXLE	FRONT SUSPENSION	TIRES	ROAD WHEEL	DRIVE SHAFT	BRAKES	STEERING	

x: Applicable

A
B
C
DLN
E
F
G
H
I
J
K
L
M
N
O
P

DESCRIPTION

< SYSTEM DESCRIPTION >

[FRONT FINAL DRIVE: R180A]

DESCRIPTION

Cross-Sectional View

INFOID:000000007323993

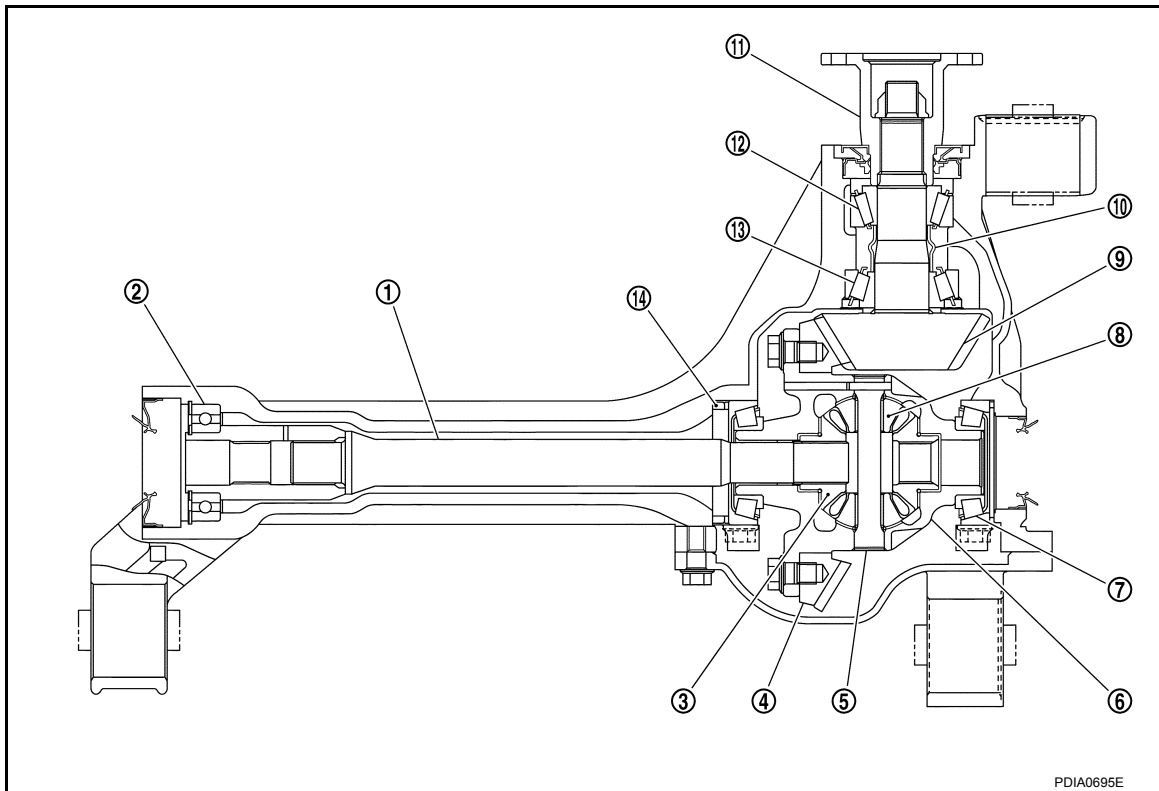

- | | | |
|-------------------------------|------------------------------------|--------------------------------|
| 1. Differential side shaft | 2. Differential side shaft bearing | 3. Side gear |
| 4. Drive gear | 5. Pinion mate shaft | 6. Differential case |
| 7. Side bearing | 8. Pinion mate gear | 9. Drive pinion |
| 10. Collapsible spacer | 11. Companion flange | 12. Drive pinion front bearing |
| 13. Drive pinion rear bearing | 14. Housing spacer | |

PERIODIC MAINTENANCE

DIFFERENTIAL GEAR OIL

Changing Differential Gear Oil

INFOID:000000007323994

DRAINING

1. Stop the engine.
2. Remove the drain plug and gasket from the front final drive assembly to drain the differential gear oil.
3. Install the drain plug with a new gasket to the front final drive assembly. Tighten to the specified torque. Refer to [DLN-196, "Disassembly and Assembly"](#).

CAUTION:
Do not reuse gasket.

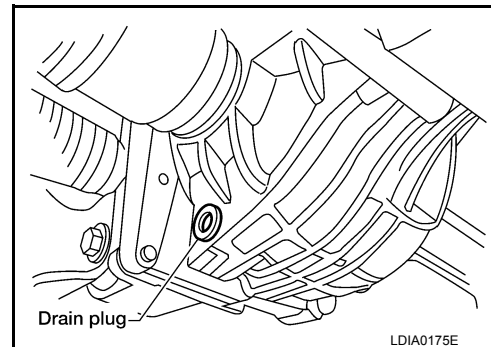

FILLING

1. Remove the filler plug and gasket from the front final drive assembly.
2. Fill the front final drive assembly with new differential gear oil until the level reaches the specified level near the filler plug hole.

Differential gear oil grade and capacity : Refer to [MA-18, "FOR USA AND CANADA : Fluids and Lubricants"](#) (United States and Canada) and [MA-20, "FOR MEXICO : Fluids and Lubricants"](#) (Mexico).

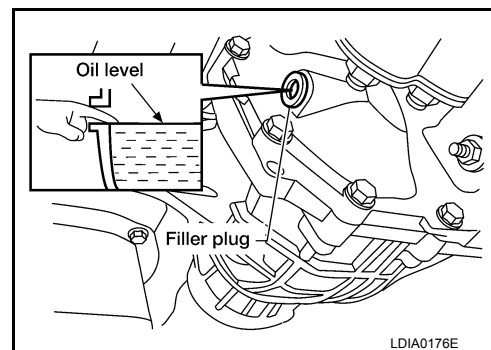

3. Install the filler plug with a new gasket on it to the front final drive assembly. Tighten to the specified torque. Refer to [DLN-196, "Disassembly and Assembly"](#).

CAUTION:
Do not reuse gasket.

Checking Differential Gear Oil

INFOID:000000007323995

DIFFERENTIAL GEAR OIL LEAKAGE AND LEVEL

1. Make sure that differential gear oil is not leaking from the front final drive assembly or around it.
2. Check the differential gear oil level from the filler plug hole as shown.

CAUTION:
Do not start engine while checking differential gear oil level.

3. Install the filler plug with a new gasket on it to the front final drive assembly. Tighten to the specified torque. Refer to [DLN-196, "Disassembly and Assembly"](#).

CAUTION:
Do not reuse gasket.

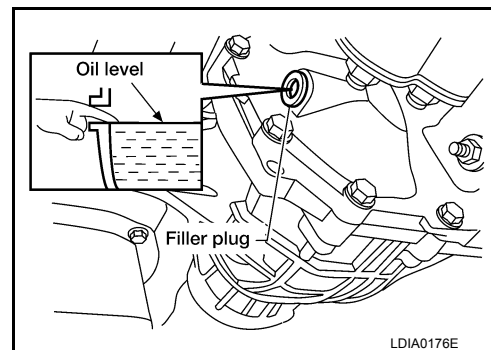

A
B
C
DLN
E
F
G
H
I
J
K
L
M
N
O
P

REMOVAL AND INSTALLATION

FRONT OIL SEAL

Removal and Installation

INFOID:000000007323996

NOTE:

When removing components such as hoses, tubes/lines, etc., cap or plug openings to prevent fluid from spilling.

REMOVAL

1. Remove the drive shafts from the front final drive assembly. Refer to [FAX-6, "Removal and Installation"](#).
2. Remove the front propeller shaft from the front final drive assembly. Refer to [DLN-137, "Removal and Installation"](#).
3. Measure the total preload torque. Refer to [DLN-196, "Disassembly and Assembly"](#).

NOTE:

Record the total preload torque measurement.

4. Remove the drive pinion lock nut using suitable tool.
5. Put matching marks on the companion flange and drive pinion using paint.

CAUTION:

Use paint to make the matching marks. Do not damage the companion flange or drive pinion.

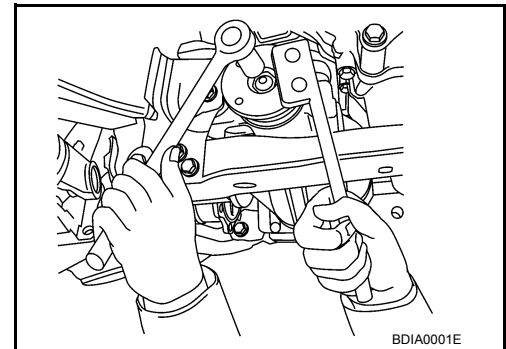

BDIA0001E

6. Remove the companion flange using suitable tool.

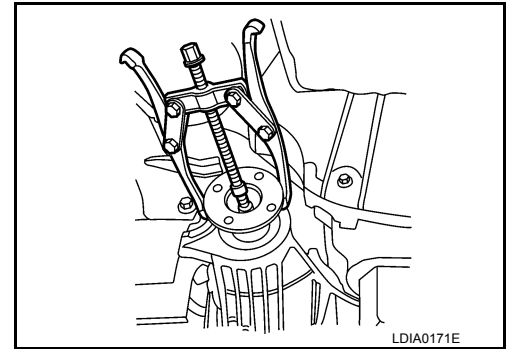

LDIA0171E

7. Remove the front oil seal using Tool.

Tool number : ST33290001 (J-34286)

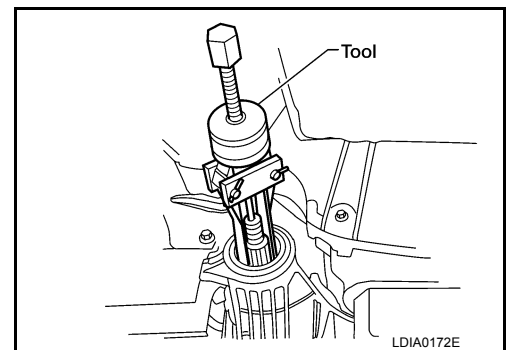

LDIA0172E

INSTALLATION

FRONT OIL SEAL

< REMOVAL AND INSTALLATION >

[FRONT FINAL DRIVE: R180A]

1. Apply multi-purpose grease to the lips and differential gear oil to the circumference of the new front oil seal. Then drive the new front oil seal in evenly until it becomes flush with the gear carrier using Tools.

Tool number (A): ST30720000 (J-25405)
(B): ST27863000 (—)

CAUTION:

- Do not reuse front oil seal.
- Do not incline the new front oil seal when installing.
- Apply multi-purpose grease to the lips and differential gear oil to the circumference of the new front oil seal.

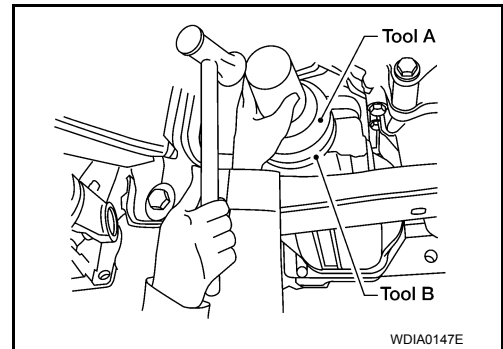

2. Install the companion flange to the drive pinion while aligning the matching marks.
3. Apply anti-corrosive oil to the threads of the drive pinion and the seating surface of the new drive pinion lock nut. Then adjust the drive pinion lock nut tightening torque using suitable tool (A), and check the total preload torque using Tool (B).

Tool number (B): ST3127S000 (J-25765-A)

Total preload torque: Refer to [DLN-196, "Disassembly and Assembly"](#).

- The total preload torque should be within the total preload torque specification. When not replacing the collapsible spacer, it should also be equal to the measurement taken during removal plus an additional 0.56 N·m (0.06 Kg-m, 5 in-lb).
- If the total preload torque is low, tighten the drive pinion lock nut in 6.8 N·m (0.69 Kg-m, 5ft-lb) increments until the total preload torque is met.

CAUTION:

- Do not reuse drive pinion lock nut.
- Apply anti-corrosive oil to the threads of the drive pinion and the seating surface of the new drive pinion lock nut.
- Adjust the drive pinion lock nut tightening torque to the lower limit first. Do not exceed the drive pinion lock nut specified torque. Refer to [DLN-196, "Disassembly and Assembly"](#).
- Do not loosen drive pinion lock nut to adjust the total preload torque. If the drive pinion lock nut torque or the total preload torque exceeds the specifications, replace the collapsible spacer and tighten it again to adjust. Refer to [DLN-196, "Disassembly and Assembly"](#).
- After adjustment, rotate drive pinion back and forth 2 to 3 times to check for unusual noise, rotation malfunction, and other malfunctions.

4. Install new side oil seals into the front final drive assembly. Refer to [DLN-192, "Removal and Installation"](#).
5. Installation of the remaining components is in the reverse order of removal.

CAUTION:

Check the differential gear oil level and refill as necessary. Refer to [DLN-189, "Checking Differential Gear Oil"](#).

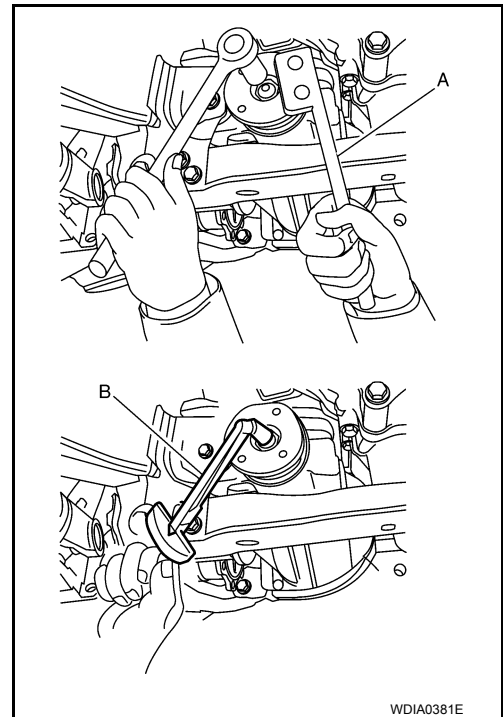

SIDE OIL SEAL

< REMOVAL AND INSTALLATION >

[FRONT FINAL DRIVE: R180A]

SIDE OIL SEAL

Removal and Installation

INFOID:000000007323997

REMOVAL

1. Remove the drive shafts from the front final drive assembly. Refer to [FAX-6, "Removal and Installation"](#).
2. Remove the side oil seal using suitable tool.

CAUTION:

Do not reuse the side oil seal.

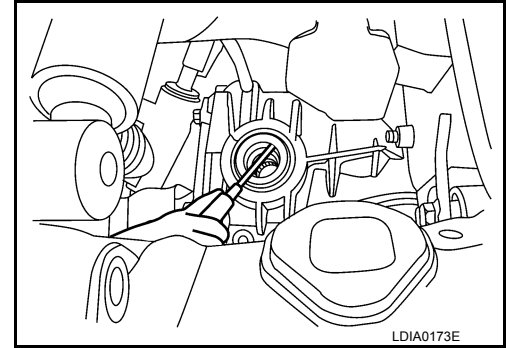

INSTALLATION

1. Apply multi-purpose grease to the lips and differential gear oil to the circumference of the new side oil seal. Then drive the new side oil seal in evenly until it becomes flush with the gear carrier using Tools.

Tool number (A): ST30720000 (J-25405)
 (B): ST27863000 (—)

CAUTION:

- Do not reuse side oil seal.
- Do not incline the new side oil seal when installing.
- Apply multi-purpose grease to the lips and differential gear oil to the circumference of the new side oil seal.

2. Installation of the remaining components is in the reverse order of removal.

CAUTION:

Check the differential gear oil level and refill as necessary. Refer to [DLN-189, "Checking Differential Gear Oil"](#).

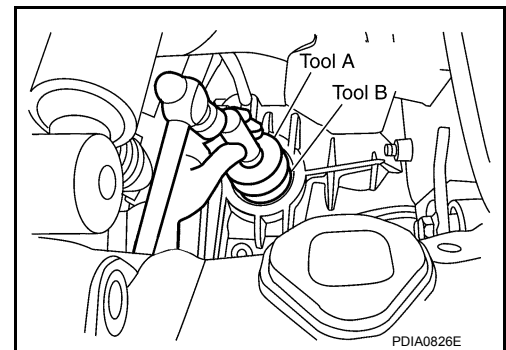

CARRIER COVER

< REMOVAL AND INSTALLATION >

[FRONT FINAL DRIVE: R180A]

CARRIER COVER

Removal and Installation

INFOID:000000007323998

REMOVAL

1. Drain the differential gear oil. Refer to [DLN-189, "Changing Differential Gear Oil"](#).
2. Remove the front final drive assembly. Refer to [DLN-194, "Removal and Installation"](#).
3. Remove the carrier cover bolts and separate the carrier cover from the gear carrier using Tool.

Tool number : KV10111100 (J-37228)

CAUTION:

- Do not damage the mating surface.
- Do not insert flat-bladed screwdriver, this will damage the mating surface.

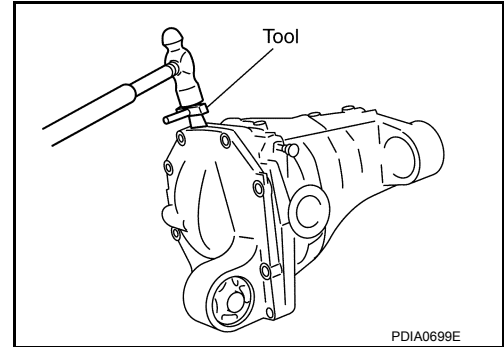

INSTALLATION

1. Apply a 3 mm (0.12 in) bead of sealant to the mating surface of the carrier cover as shown.
 - Use Genuine Silicone RTV or equivalent. Refer to [GI-22, "Recommended Chemical Products and Sealants"](#).

CAUTION:

Remove any old sealant adhering to the mating surfaces. Also remove any moisture, oil, or foreign material adhering to the application and mating surfaces.

2. Install the carrier cover to the gear carrier. Tighten the bolts to the specified torque. Refer to [DLN-196, "Disassembly and Assembly"](#).
3. Install the front final drive assembly. Refer to [DLN-194, "Removal and Installation"](#).

CAUTION:

Fill the front final drive assembly with recommended differential gear oil. Refer to [DLN-189](#).

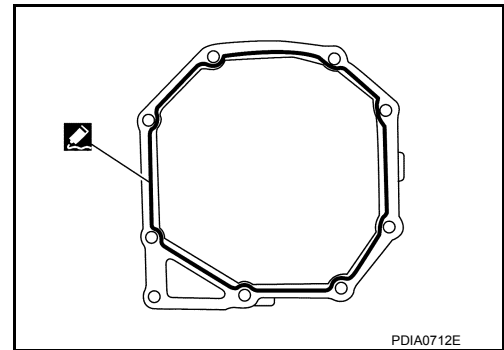

A
B
C
DLN
E
F
G
H
I
J
K
L
M
N
O
P

FRONT FINAL DRIVE ASSEMBLY

< UNIT REMOVAL AND INSTALLATION >

[FRONT FINAL DRIVE: R180A]

4. Disconnect the vent hose from the front final drive assembly.
5. Support the front final drive assembly using a suitable jack.
6. Remove the front final drive assembly bolts, then remove the front final drive assembly.

CAUTION:

Support the front final drive assembly while removing using a suitable jack.

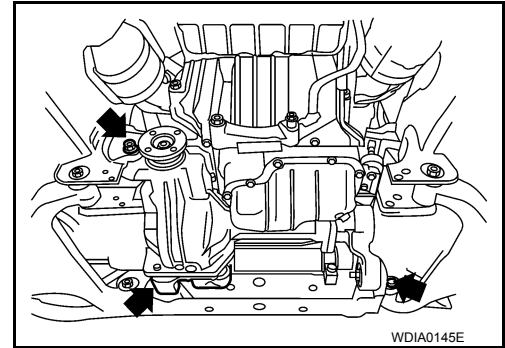

INSTALLATION

Installation is in the reverse order of removal.

- Install new side oil seals into the front final drive assembly. Refer to [DLN-192, "Removal and Installation"](#).

CAUTION:

- **Make sure there are no pinched or restricted areas on the breather hose caused by folding or bending when installing it.**
- **Check the front final drive assembly differential gear oil and refill as necessary. Refer to [DLN-189](#).**

A
B
C
DLN
E
F
G
H
I
J
K
L
M
N
O
P

FRONT FINAL DRIVE

< UNIT DISASSEMBLY AND ASSEMBLY >

[FRONT FINAL DRIVE: R180A]

UNIT DISASSEMBLY AND ASSEMBLY

FRONT FINAL DRIVE

Disassembly and Assembly

INFOID:000000007324000

COMPONENTS

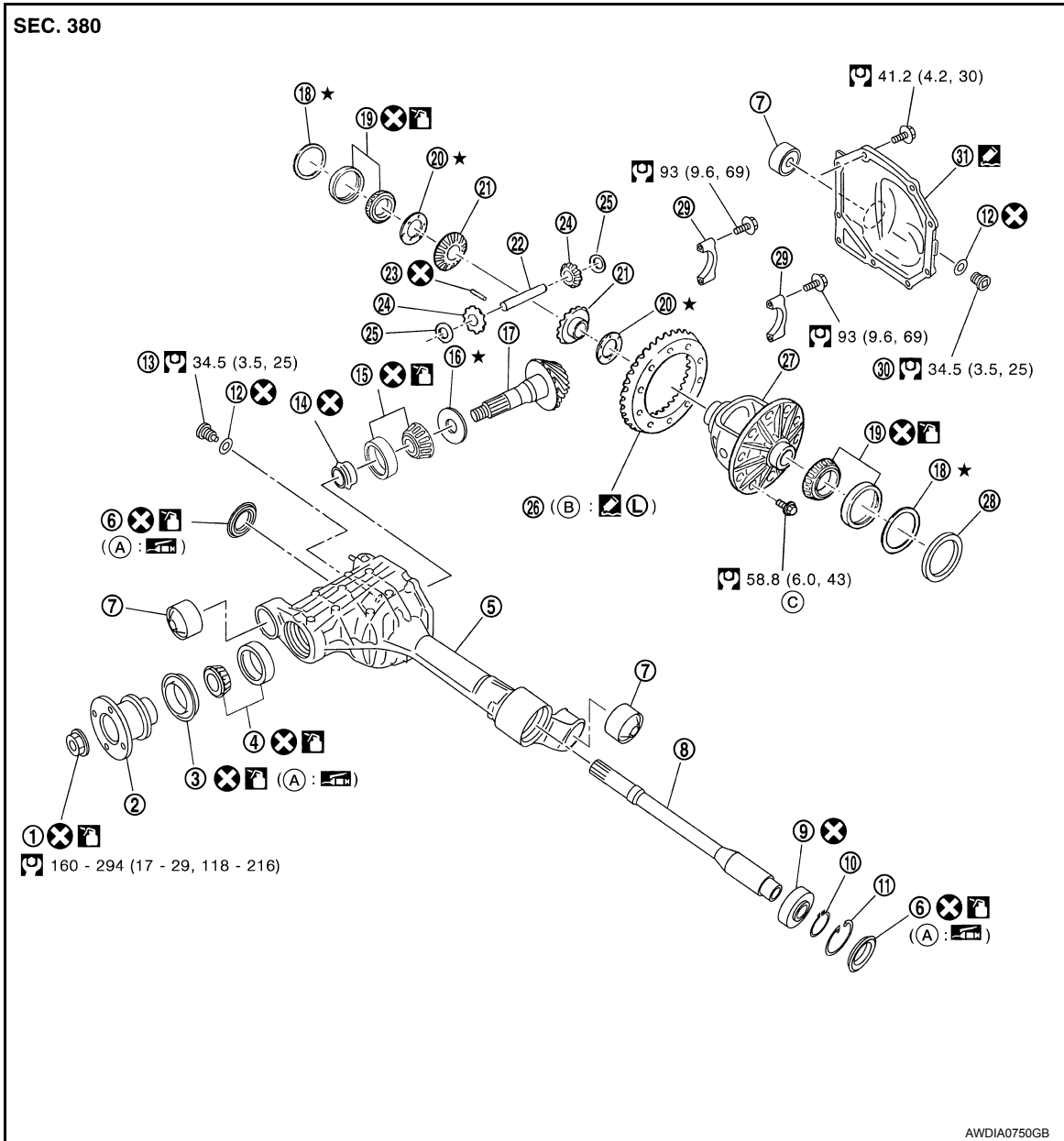

- | | | |
|--|-----------------------------|------------------------------------|
| 1. Drive pinion lock nut | 2. Companion flange | 3. Front oil seal |
| 4. Drive pinion front bearing | 5. Gear carrier | 6. Side oil seal |
| 7. Bushing | 8. Differential side shaft | 9. Differential side shaft bearing |
| 10. Snap ring | 11. Snap ring | 12. Gasket |
| 13. Drain plug | 14. Collapsible spacer | 15. Drive pinion rear bearing |
| 16. Drive pinion height adjusting washer | 17. Drive pinion | 18. Side bearing adjusting washer |
| 19. Side bearing | 20. Side gear thrust washer | 21. Side gear |
| 22. Pinion mate shaft | 23. Lock pin | 24. Pinion mate gear |
| 25. Pinion mate thrust washer | 26. Drive gear | 27. Differential case |

FRONT FINAL DRIVE

< UNIT DISASSEMBLY AND ASSEMBLY >

[FRONT FINAL DRIVE: R180A]

- | | | |
|----------------------------|----------------------|-----------------|
| 28. Housing spacer | 29. Side bearing cap | 30. Filler plug |
| 31. Carrier cover | A. Seal lip | B. Screw holes |
| C. Refer to "INSTALLATION" | | |

ASSEMBLY INSPECTION AND ADJUSTMENT

- Drain the differential gear oil before inspection and adjustment. Refer to [DLN-189](#).
- Remove and install the carrier cover as necessary for inspection and adjustment. Refer to [DLN-193](#).

Total Preload Torque

1. Install the differential side shaft if necessary. Refer to [DLN-192, "Removal and Installation"](#).
CAUTION:
The differential side shaft must be installed in order to measure total preload torque.
2. Rotate the drive pinion back and forth 2 to 3 times to check for unusual noise and rotation malfunction.
3. Rotate the drive pinion at least 20 times to check for smooth operation of the bearings.
4. Measure total preload torque using Tool.

Tool number : ST3127S000 (J-25765-A)

Total preload torque:
Refer to [DLN-196, "Disassembly and Assembly"](#)

NOTE:

Total preload torque = Drive pinion bearing preload torque + Side bearing preload torque

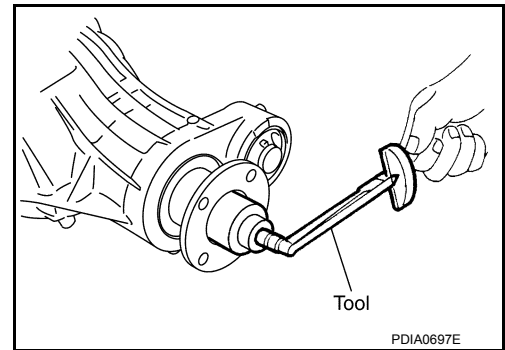

- If the measured value is out of the specification, check and adjust each part. Adjust the drive pinion bearing preload torque first, then adjust the side bearing preload torque.

If the total preload torque is greater than specification

On drive pinion bearings: Replace the collapsible spacer.

On side bearings: Use thinner side bearing adjusting washers by the same amount on each side. Refer to [DLN-215, "Inspection and Adjustment"](#).

If the total preload torque is less than specification

On drive pinion bearings: Tighten the drive pinion lock nut.

On side bearings: Use thicker side bearing adjusting washers by the same amount on each side. Refer to [DLN-215, "Inspection and Adjustment"](#).

CAUTION:

Select a side bearing adjusting washer for right and left individually.

Drive Gear Runout

1. Fit a dial indicator to the drive gear back face.
2. Rotate the drive gear to measure runout.

Runout limit: Refer to [DLN-215, "Inspection and Adjustment"](#)

- If the runout is outside of the limit, check the condition of the drive gear assembly. Foreign material may be caught between the drive gear and differential case, or the differential case or drive gear may be deformed.

CAUTION:

Replace drive gear and drive pinion as a set.

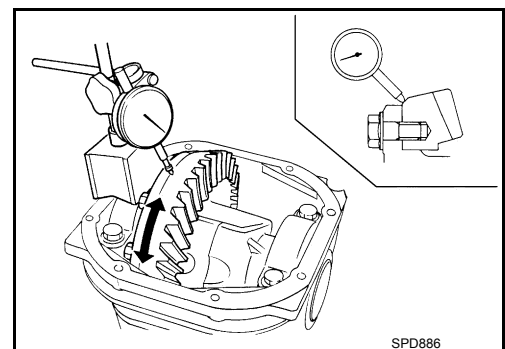

FRONT FINAL DRIVE

< UNIT DISASSEMBLY AND ASSEMBLY >

[FRONT FINAL DRIVE: R180A]

Tooth Contact

1. Apply red lead to the drive gear.

NOTE:

Apply red lead to both faces of three to four gears, at four locations evenly spaced on the drive gear.

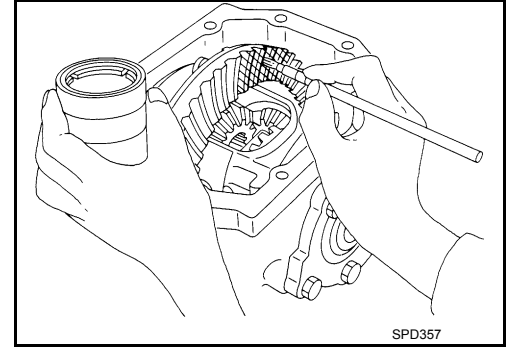

2. Rotate the drive gear back and forth several times. Then check for correct drive pinion to drive gear tooth contact as shown.

CAUTION:

Check tooth contact on drive side and reverse side.

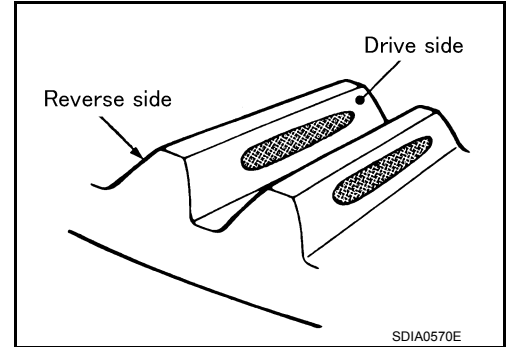

- If the tooth contact is improperly adjusted, adjust the drive pinion height (dimension X).

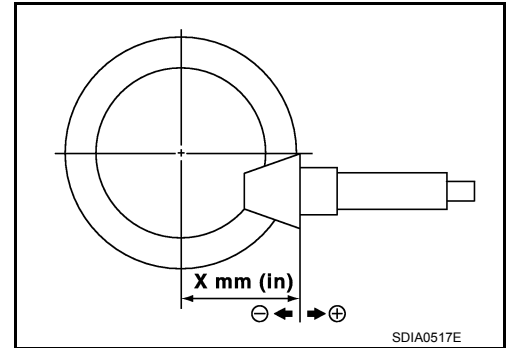

- If the tooth contact is near the face (face contact), or near the heel (heel contact), use a thicker drive pinion height adjusting washer to move drive pinion closer to the drive gear.

Refer to [DLN-215. "Inspection and Adjustment"](#).

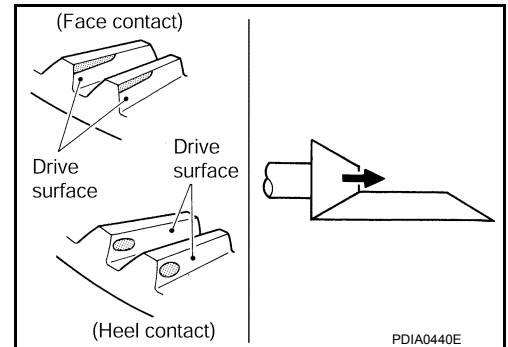

FRONT FINAL DRIVE

< UNIT DISASSEMBLY AND ASSEMBLY >

[FRONT FINAL DRIVE: R180A]

- If the tooth contact is near the flank (flank contact), or near the toe (toe contact), use a thinner drive pinion height adjusting washer to move the drive pinion farther from the drive gear. Refer to [DLN-215, "Inspection and Adjustment"](#).

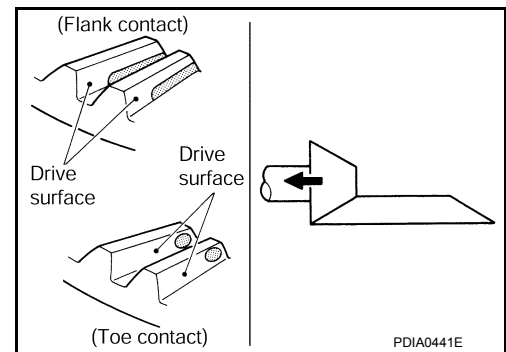

Backlash

1. Fit a dial indicator to the drive gear face to measure the backlash.

Backlash: Refer to [DLN-215, "Inspection and Adjustment"](#)

- If the backlash is outside of the specification, change the thickness of the side bearing adjusting washers.

If the backlash is greater than specification:

Make side bearing adjusting washer thicker on drive gear back side, and side bearing adjusting washer thinner on drive gear tooth side by the same amount. Refer to [DLN-215, "Inspection and Adjustment"](#).

If the backlash is less than specification:

Make side bearing adjusting washer thinner on drive gear back side, and side bearing adjusting washer thicker on drive gear tooth side by the same amount. Refer to [DLN-215, "Inspection and Adjustment"](#).

CAUTION:

Do not change the total thickness of side bearing adjusting washers as it will change the side bearing preload torque.

Companion Flange Runout

1. Rotate companion flange and check for runout on the companion flange face (inner side of the bolt holes) and companion flange inner side (socket diameter) using suitable tool.

Runout limit: Refer to [DLN-215, "Inspection and Adjustment"](#)

2. If the runout is outside the runout limit, follow the procedure below to adjust.
 - a. Rotate the companion flange on the drive pinion by 90°, 180° and 270° while checking for the position where the runout is minimum.
 - b. If the runout is still outside of the runout limit after the companion flange has been rotated on the drive pinion, possible cause could be an assembly malfunction of drive pinion and drive pinion bearing or a malfunctioning drive pinion bearing.
 - c. If the runout is still outside of the runout limit after repair of the assembly of drive pinion and drive pinion bearing or drive pinion bearing, replace the companion flange.

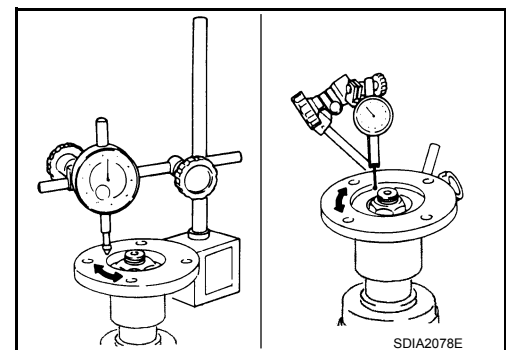
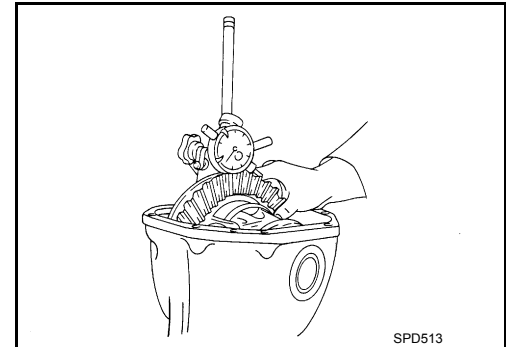

DISASSEMBLY

Differential side shaft

1. Drain the differential gear oil if necessary.

A
B
C
DLN
E
F
G
H
I
J
K
L
M
N
O
P

FRONT FINAL DRIVE

< UNIT DISASSEMBLY AND ASSEMBLY >

[FRONT FINAL DRIVE: R180A]

2. Remove the carrier cover bolts and separate the carrier cover from the gear carrier using Tool.

Tool number : KV10111100 (J-37228)

CAUTION:

- Do not damage the mating surface.
- Do not insert flat-bladed screwdriver, this will damage the mating surface.

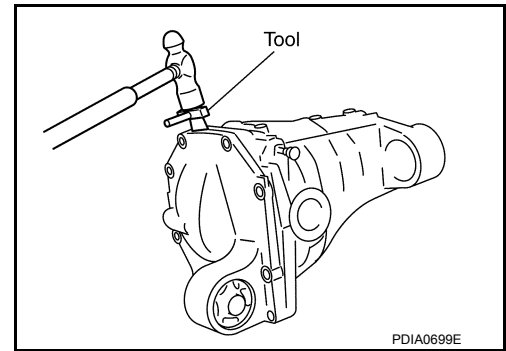

3. Remove side oil seal.

CAUTION:

Do not damage gear carrier.

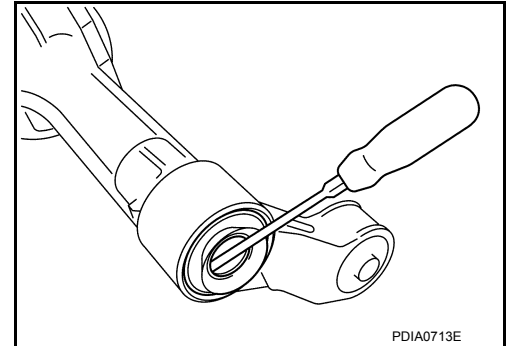

4. Remove snap ring (hole side) using suitable tool.

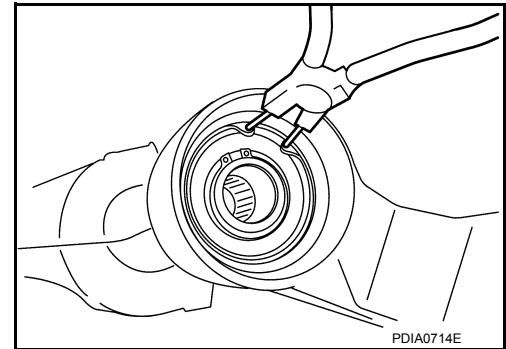

5. Remove differential side shaft assembly out of gear carrier using suitable tool.

NOTE:

Tap on differential side shaft assembly from side gear side.

6. Remove snap ring (differential side shaft side).

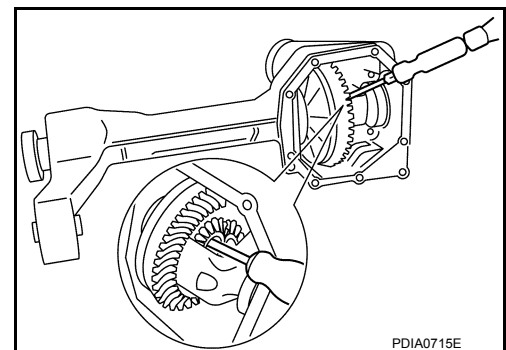

7. Press differential side shaft out of differential side shaft bearing.

CAUTION:

Do not drop differential side shaft.

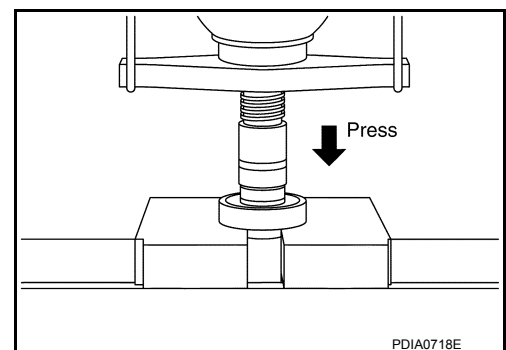

FRONT FINAL DRIVE

< UNIT DISASSEMBLY AND ASSEMBLY >

[FRONT FINAL DRIVE: R180A]

Differential Assembly

1. Remove differential side shaft assembly. Refer to [DLN-192. "Removal and Installation"](#).
2. Remove side seal from gear carrier using suitable tool.
3. For proper reinstallation, paint matching marks on one side of the side bearing cap and gear carrier.

CAUTION:

- For matching marks, use paint. Do not damage side bearing cap or gear carrier.
- Side bearing caps are line-board during manufacture. The matching marks are used to reinstall them in their original positions.

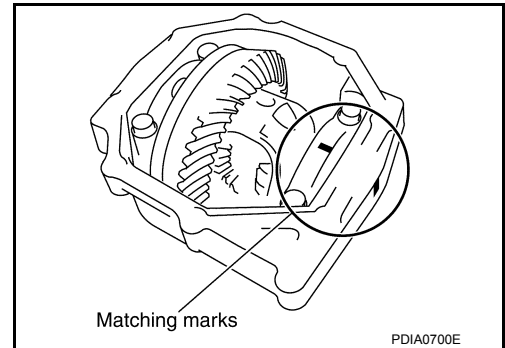

4. Remove the side bearing caps.

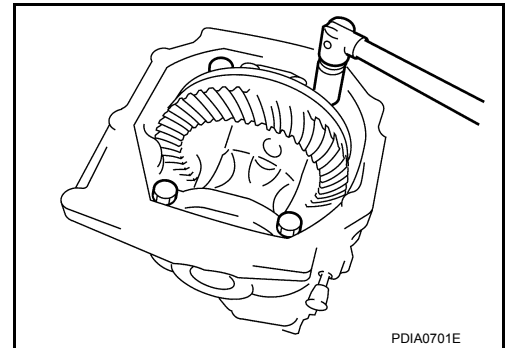

5. Lift the differential case assembly out of the gear carrier.

CAUTION:

- Keep side bearing outer races together with side bearing inner races. Do not mix them up.
- Keep side bearing adjusting washers together with side bearings.

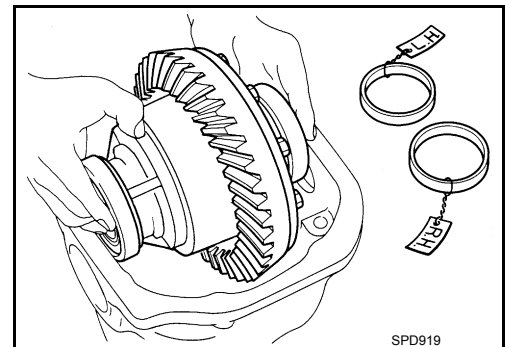

6. Remove housing spacer.
7. Remove side bearing inner race using Tools as shown.

Tool number (A): ST33051001 (J-22888-20)
(B): ST33061000 (J-8107-2)

CAUTION:

- Do not remove side bearing inner race unless it is being replaced.
- Place copper plates between the vise and the side bearing inner race and drive gear to prevent damage.

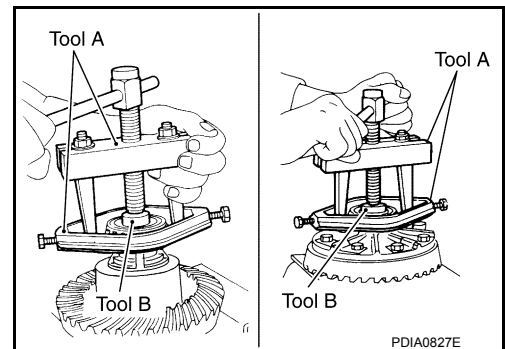

A
B
C
DLN
E
F
G
H
I
J
K
L
M
N
O
P

FRONT FINAL DRIVE

< UNIT DISASSEMBLY AND ASSEMBLY >

[FRONT FINAL DRIVE: R180A]

- Keep side bearing outer races together with side bearing inner races. Do not mix them up.

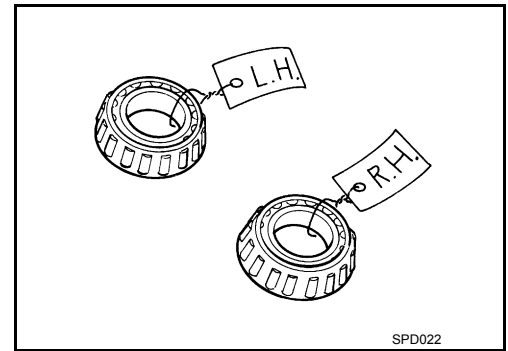

8. For proper reinstallation, paint matching marks on the differential case and drive gear.

CAUTION:

Use paint for matching marks. Do not damage differential case or drive gear.

9. Remove the drive gear bolts.

10. Tap the drive gear off the differential case using suitable tool.

CAUTION:

Tap evenly all around to keep drive gear from bending.

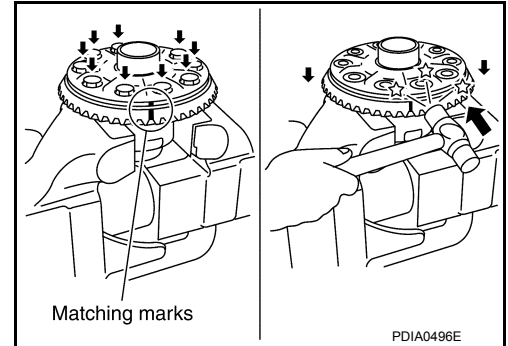

11. Remove the lock pin of the pinion mate shaft from the drive gear side using suitable tool.

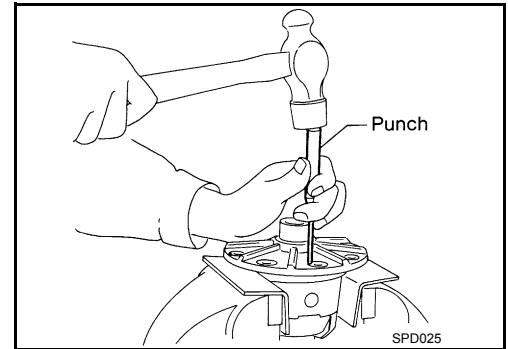

12. Remove the pinion mate shaft.

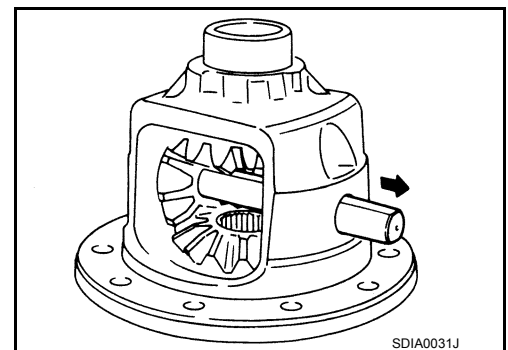

13. Turn the pinion mate gear, then remove the pinion mate gear, pinion mate thrust washer, side gear and side gear thrust washer from the differential case.

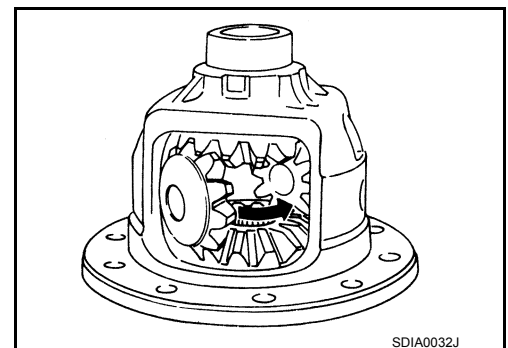

FRONT FINAL DRIVE

< UNIT DISASSEMBLY AND ASSEMBLY >

[FRONT FINAL DRIVE: R180A]

Drive Pinion Assembly

1. Remove the differential assembly. Refer to [DLN-196, "Disassembly and Assembly"](#).
2. Remove the drive pinion lock nut using suitable tool.
3. Put matching marks on the companion flange and drive pinion using paint.

CAUTION:

Use paint to make the matching marks. Do not damage the companion flange or drive pinion.

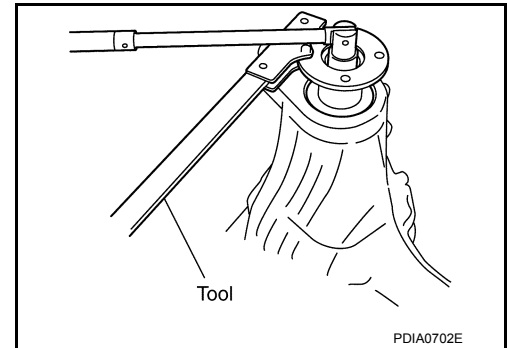

4. Remove the companion flange using suitable tool.

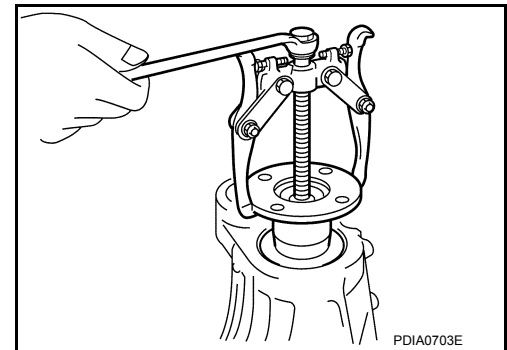

5. Press the drive pinion assembly (with rear inner bearing race and collapsible spacer) out of the gear carrier.

CAUTION:

Do not drop drive pinion assembly.

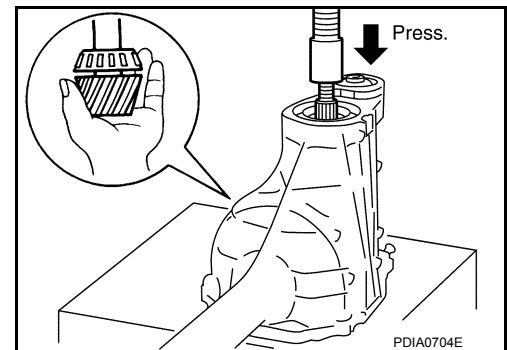

6. Remove the drive pinion rear bearing inner race and drive pinion height adjusting washer using Tool.

Tool number : ST30031000 (J-22912-01)

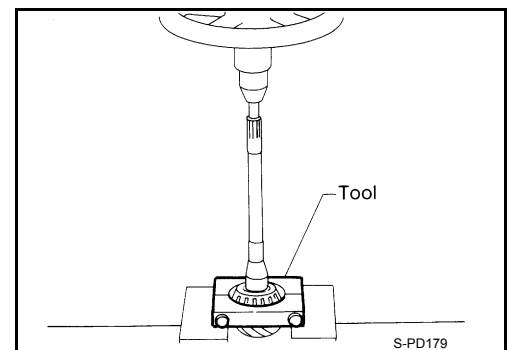

A
B
C
DLN
E
F
G
H
I
J
K
L
M
N
O
P

FRONT FINAL DRIVE

< UNIT DISASSEMBLY AND ASSEMBLY >

[FRONT FINAL DRIVE: R180A]

7. Remove the front oil seal using suitable tool.

CAUTION:

Do not damage gear carrier.

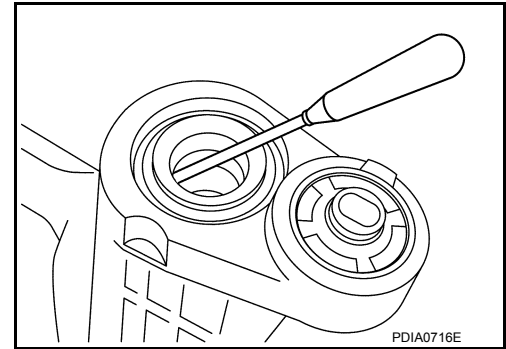

8. Remove the drive pinion front bearing inner race.
9. Remove the drive pinion front and rear bearing outer races by tapping them uniformly using suitable tool.

CAUTION:

Do not damage gear carrier.

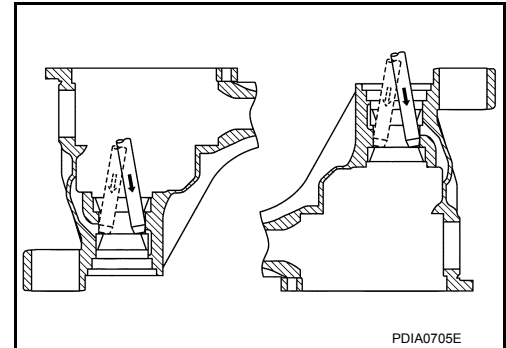

INSPECTION AFTER DISASSEMBLY

Clean the disassembled parts. Then inspect the parts for wear or damage. If wear or damage are found, follow the measures below.

Drive Pinion and Drive Gear

- If the drive pinion and drive gear teeth do not mesh or line-up correctly, determine the cause and adjust, repair, or replace as necessary.
- If the drive pinion or drive gear are worn, cracked, damaged, pitted or chipped (by friction) noticeably, replace with new drive pinion and drive gear.
- Drive pinion and drive gear are supplied in matched sets only. Matching numbers on both drive pinion and drive gear are etched for verification. If a new drive pinion and drive gear set are being used, verify the numbers of each drive pinion and drive gear before proceeding with assembly.

Bearing

- If bearings are chipped (by friction), pitted, worn, rusted, scratched, or unusual noise is coming from bearing, replace with new bearing assembly (as a new set).
- Bearing must be replaced with a new one whenever disassembled.

Side Gear and Pinion Mate Gear

- If any cracks or damage are found on the surface of the teeth, replace with new one.
- If any worn or chipped marks are found on the side of the side gear and pinion mate gear which contact the thrust washer, replace with new one.
- Replace both side gear and pinion mate gear as a set when replacing side gear or pinion mate gear.

Side Gear Thrust Washer and Pinion Mate Thrust Washer

- If any chips (by friction), damage, or unusual wear are found, replace with new one.

Gear Carrier

- If any wear or cracks are found on the contact sides of gear carrier, replace with new one.

Companion Flange

- If any chips (about 0.1mm, 0.004 in) or other damage on the companion flange surface which contacts the front oil seal lips are found, replace with new one.

ADJUSTING AND SELECTING WASHERS

Side Gear Back Clearance

- Assemble the differential parts if they are disassembled. Refer to [DLN-196. "Disassembly and Assembly"](#).

FRONT FINAL DRIVE

< UNIT DISASSEMBLY AND ASSEMBLY >

[FRONT FINAL DRIVE: R180A]

1. Place the differential case straight up so that the side gear to be measured is upward.

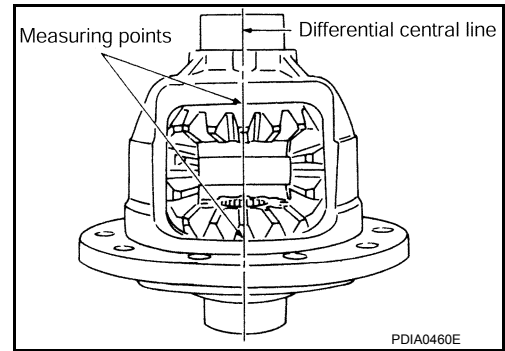

2. Using feeler gauges, measure the clearance between the side gear back and differential case at three different points, while rotating the side gear. Average the three readings to calculate the clearance. (Measure the clearance of the other side as well.)

Side gear back clearance: Refer to [DLN-215, "Inspection and Adjustment"](#)

- If the side gear back clearance is outside of the specification, use a thicker or thinner side gear thrust washer to adjust. Refer to [DLN-215, "Inspection and Adjustment"](#).

If the side gear back clearance is greater than specification:

Use a thicker side gear thrust washer.

If the side gear back clearance is less than specification:

Use a thinner side gear thrust washer.

CAUTION:

- Insert feeler gauges with the same thickness on both sides to prevent side gear from tilting.
- Each gear should rotate smoothly without excessive resistance during differential motion.
- Select a side gear thrust washer for right and left individually.

NOTE:

Side gear back clearance is clearance between side gear and differential case for adjusting side gear backlash.

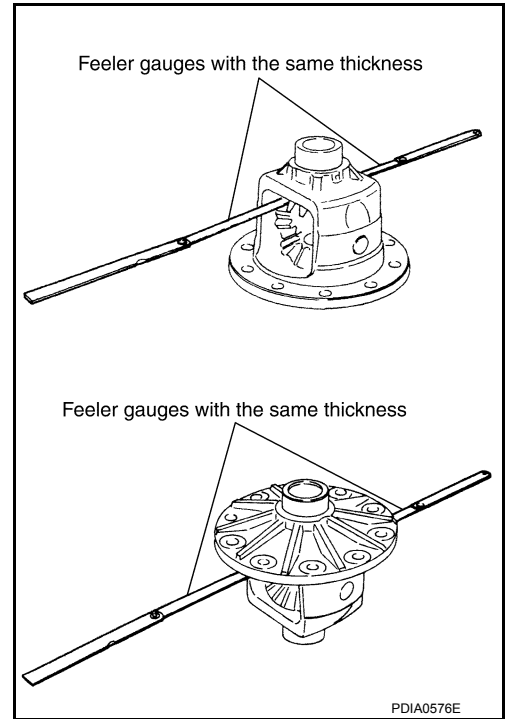

Drive Pinion Height

1. Make sure all parts are clean and that the bearings are well lubricated.
2. Assemble the drive pinion bearings onto the Tool.

Tool number : — (J-34309)

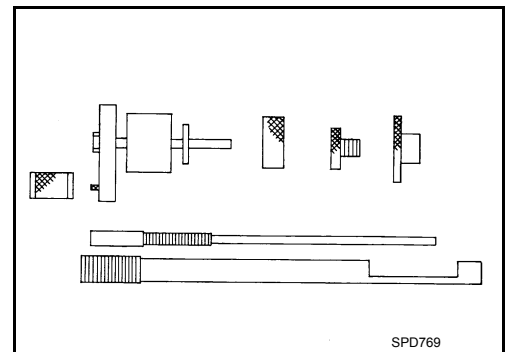

A
B
C
DLN
E
F
G
H
I
J
K
L
M
N
O
P

FRONT FINAL DRIVE

< UNIT DISASSEMBLY AND ASSEMBLY >

[FRONT FINAL DRIVE: R180A]

- **Drive pinion front bearing;** make sure the J-34309-3 drive pinion front bearing seat is secured tightly against the J-34309-2 gauge anvil. Then turn the J-34309-7 drive pinion front bearing pilot to secure the drive pinion front bearing in its proper position.
 - **Drive pinion rear bearing;** the J-34309-8 drive pinion rear bearing pilot is used to center the drive pinion rear bearing only. The J-34309-4 drive pinion rear bearing locking seat is used to lock the drive pinion rear bearing to the assembly.
 - **Installation of J-34309-9 and J-34309-16;** place a suitable 2.5 mm (0.098 in) thick plain washer between J-34309-9 and J-34309-16. Both surfaces of J-34309-9 and J-34309-16 must be parallel with a clearance of 2.5 mm (0.098 in).
3. Install the drive pinion rear bearing inner race into the gear carrier. Then insert the drive pinion height adjusting washer selector tool, J-34309-1, gauge screw assembly.

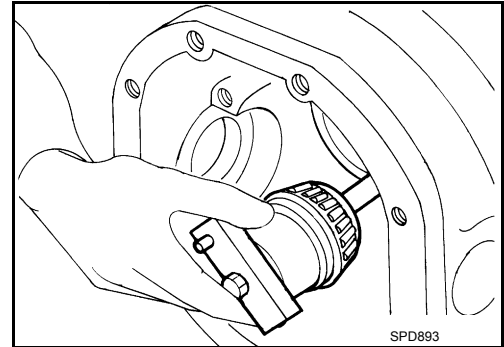
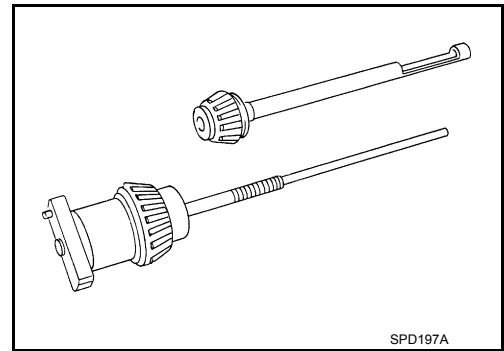

4. Assemble the drive pinion front bearing inner race and the J-34309-2 gauge anvil. Assemble them together with the J-34309-1 gauge screw in the gear carrier. Make sure that the drive pinion height gauge plate, J-34309-16, will turn a full 360°. Tighten the two sections together by hand.

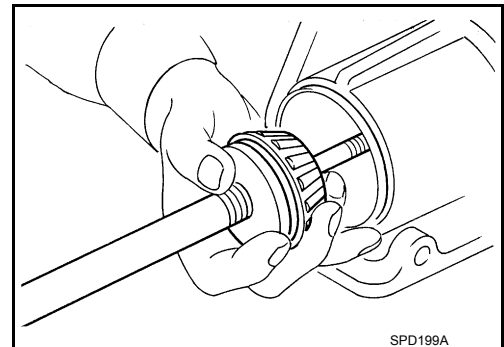

5. Turn the assembly several times to seat the drive pinion bearings.

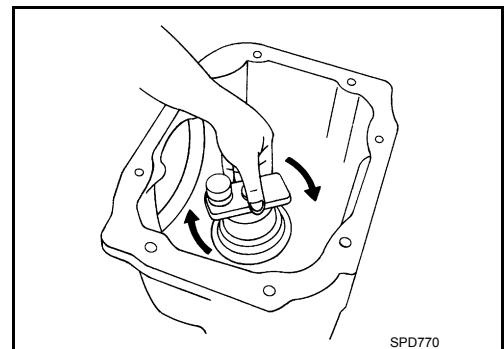

FRONT FINAL DRIVE

< UNIT DISASSEMBLY AND ASSEMBLY >

[FRONT FINAL DRIVE: R180A]

6. Measure the turning torque at the end of the J-34309-2 gauge anvil using Tool.

Tool number : ST3127S000 (J-25765- A)

Turning torque specification:

1.0 - 1.6 N·m (0.11 - 0.16 kg-m, 9 - 14 in-lb)

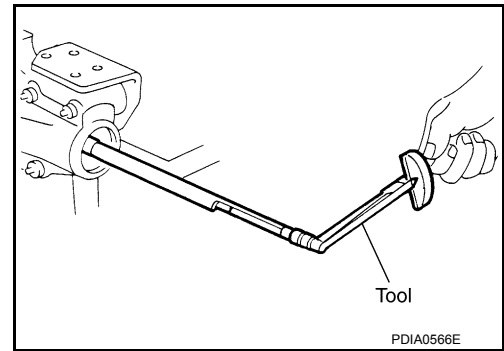

7. Place the J-34309-10 "R180A" drive pinion height adapter onto the gauge plate and tighten it by hand.

CAUTION:

Make sure all machined surfaces are clean.

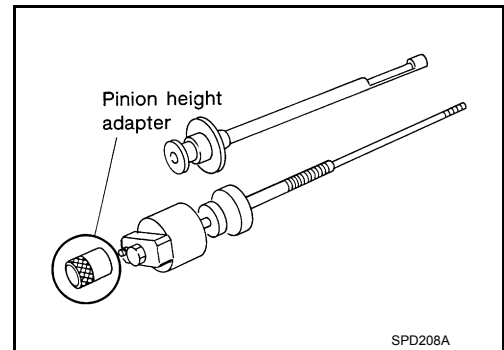

8. Position the side bearing discs, Tool, and arbor firmly into the side bearing bores. Install the side bearing caps and tighten the side bearing cap bolts to the specified torque. Refer to [DLN-196](#), "[Disassembly and Assembly](#)".

Tool number : — (J-25269-18)

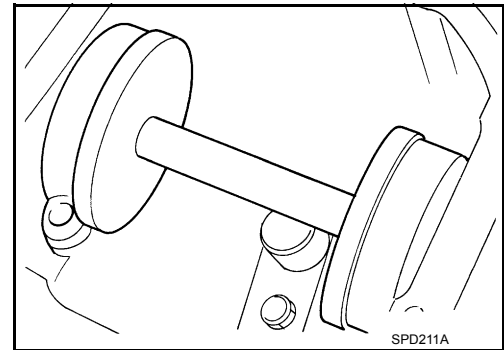

9. Select the correct standard drive pinion height adjusting washer thickness. Select by using a standard gauge of 3 mm (0.12 in) and your J-34309-101 feeler gauge. Measure the distance between the J-34309-10 drive pinion height adapter, including the standard gauge and the arbor.

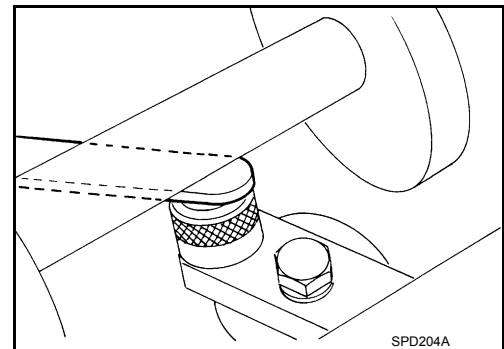

10. Write down the exact measurement (the value of feeler gauge).

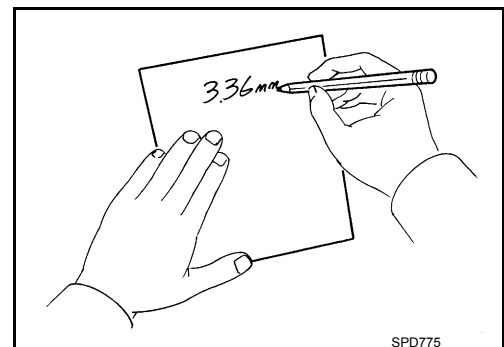

A
B
C
DLN
E
F
G
H
I
J
K
L
M
N
O
P

FRONT FINAL DRIVE

< UNIT DISASSEMBLY AND ASSEMBLY >

[FRONT FINAL DRIVE: R180A]

11. Correct the drive pinion height adjusting washer size by referring to the drive pinion “head number”.
There are two numbers painted on the drive pinion. The first one refers to the drive pinion and drive gear as a matched set. This number should be the same as the number on the drive gear. The second number is the drive pinion “head number”. It refers to the ideal drive pinion height from standard for quietest operation. Use the following chart to determine the correct drive pinion height adjusting washer.

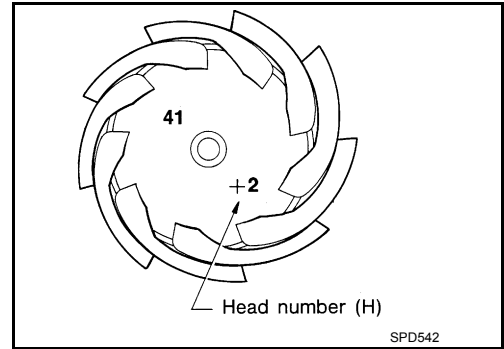

Head number	Add or remove from the standard drive pinion height adjusting washer thickness measurement
-6	Add 0.06 mm (0.0024 in)
-5	Add 0.05 mm (0.0020 in)
-4	Add 0.04 mm (0.0016 in)
-3	Add 0.03 mm (0.0012 in)
-2	Add 0.02 mm (0.0008 in)
-1	Add 0.01 mm (0.0004 in)
0	Use the selected washer thickness
+1	Subtract 0.01 mm (0.0004 in)
+2	Subtract 0.02 mm (0.0008 in)
+3	Subtract 0.03 mm (0.0012 in)
+4	Subtract 0.04 mm (0.0016 in)
+5	Subtract 0.05 mm (0.0020 in)
+6	Subtract 0.06 mm (0.0024 in)

12. Select the correct drive pinion height adjusting washer. Refer to [DLN-215. "Inspection and Adjustment"](#).
 13. Remove the Tool from the gear carrier and disassemble to retrieve the drive pinion bearings.

Tool number : — **(J-34309)**

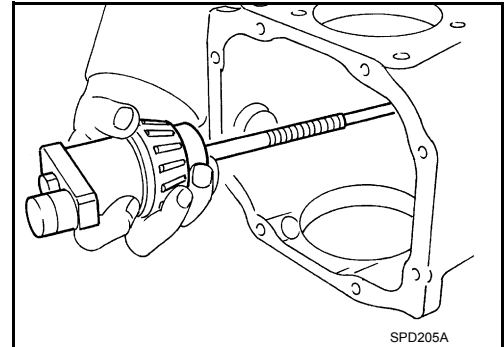

ASSEMBLY

Drive Pinion Assembly

FRONT FINAL DRIVE

< UNIT DISASSEMBLY AND ASSEMBLY >

[FRONT FINAL DRIVE: R180A]

1. Install drive pinion rear bearing outer race and drive pinion front bearing outer race using Tools.

Tool number (A): ST30611000 (J-25742-1)
 (B): ST30613000 (J-25742-3)
 (C): KV38100200 (J-26233)

CAUTION:

- First tap the drive pinion bearing outer race until it becomes flush with the gear carrier.
- Do not reuse drive pinion front and rear bearing outer race.

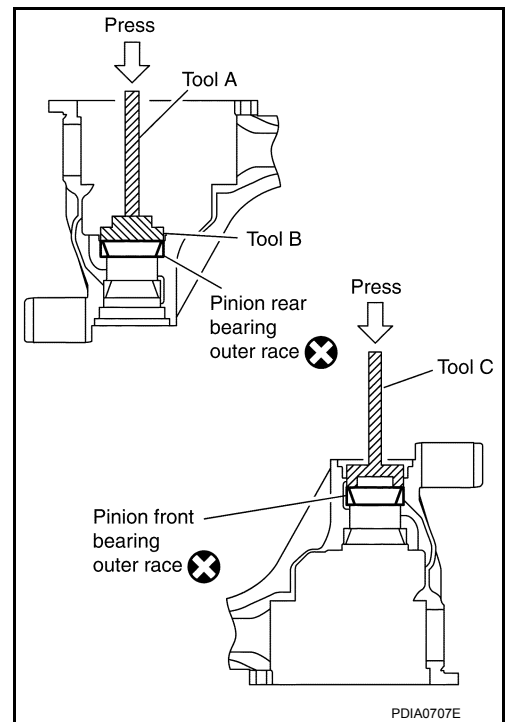

2. Select drive pinion height adjusting washer. Refer to [DLN-215. "Inspection and Adjustment"](#).
3. Install the selected drive pinion height adjusting washer to the drive pinion. Press the drive pinion rear bearing inner race to it using Tool.

Tool number : ST30901000 (J-26010-01)

CAUTION:

- Install the drive pinion height adjusting washer in the proper direction as shown.
- Do not reuse drive pinion rear bearing inner race.

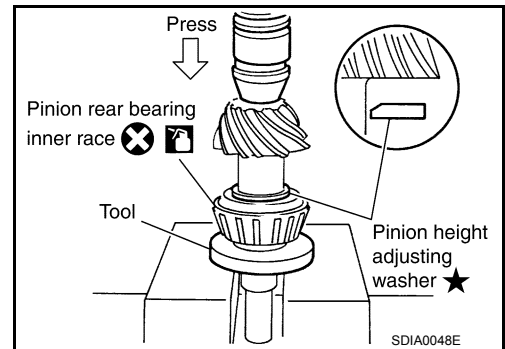

4. Install the collapsible spacer to the drive pinion.
5. Apply differential gear oil to the drive pinion rear bearing, and install the drive pinion assembly to the gear carrier.
6. Apply differential gear oil to the drive pinion front bearing, and install the drive pinion front bearing inner race to the drive pinion assembly.

CAUTION:

Do not reuse drive pinion front bearing inner race.

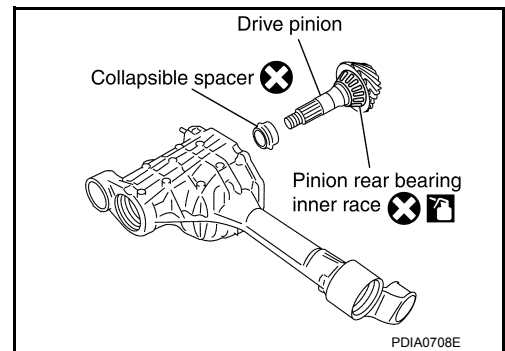

A
B
C
DLN
E
F
G
H
I
J
K
L
M
N
O
P

FRONT FINAL DRIVE

< UNIT DISASSEMBLY AND ASSEMBLY >

[FRONT FINAL DRIVE: R180A]

7. Press the drive pinion front bearing inner race to the drive pinion as far as drive pinion lock nut can be tightened using Tool.

Tool number : ST33200000 (J-26082)

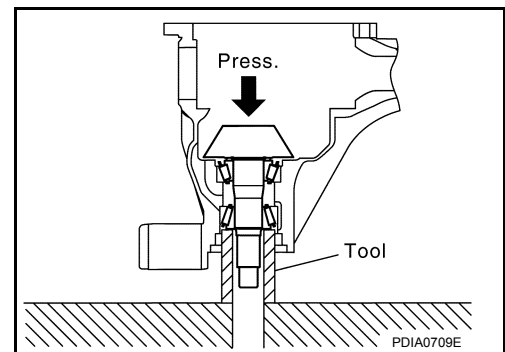

8. Apply multi-purpose grease to the lips and differential gear oil to the circumference of the new front oil seal. Then drive the new front oil seal in evenly until it becomes flush with the gear carrier using Tools.

Tool number (A): ST30720000 (J-25405)
(B): ST27863000 (—)

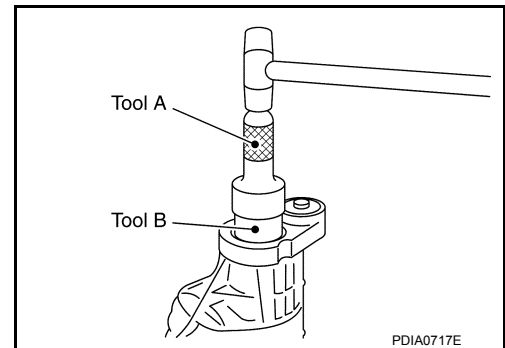

CAUTION:

- Do not reuse front oil seal.
- Do not incline the new front oil seal when installing.
- Apply multi-purpose grease to the lips and differential gear oil to the circumference of the new front oil seal.

9. Install the companion flange to the drive pinion while aligning the matching marks.
10. Apply anti-corrosive oil to the threads of the drive pinion and the seating surface of the new drive pinion lock nut. Then adjust the drive pinion lock nut tightening torque using suitable tool (A), and check the drive pinion bearing preload torque using Tool (B).

Tool number (B): ST3127S000 (J-25765-A)

Drive pinion bearing preload torque:

1.08 - 1.66 N·m (0.11 - 0.16 kg-m, 10 - 14 in-lb)

CAUTION:

- Do not reuse drive pinion lock nut.
- Apply anti-corrosive oil to the threads of the drive pinion and the seating surface of the new drive pinion lock nut.
- Adjust the drive pinion lock nut tightening torque to the lower limit first. Do not exceed the drive pinion lock nut specified torque. Refer to [DLN-196, "Disassembly and Assembly"](#).
- If the drive pinion bearing preload torque exceeds the specified value, replace collapsible spacer and tighten it again to adjust. Do not loosen drive pinion lock nut to adjust the drive pinion bearing preload torque.
- After adjustment, rotate drive pinion back and forth 2 to 3 times to check for unusual noise, rotation malfunction, and other malfunctions.

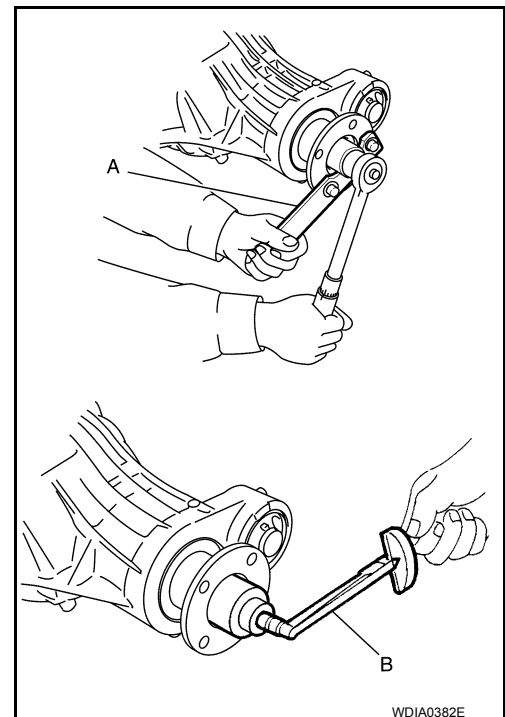

11. Check companion flange runout. Refer to [DLN-215, "Inspection and Adjustment"](#).
12. Install the differential case assembly. Refer to [DLN-196, "Disassembly and Assembly"](#).

Differential Assembly

FRONT FINAL DRIVE

< UNIT DISASSEMBLY AND ASSEMBLY >

[FRONT FINAL DRIVE: R180A]

1. Install side gear thrust washers with the same thickness as the ones installed prior to disassembly, or reinstall the old ones on the side gears.

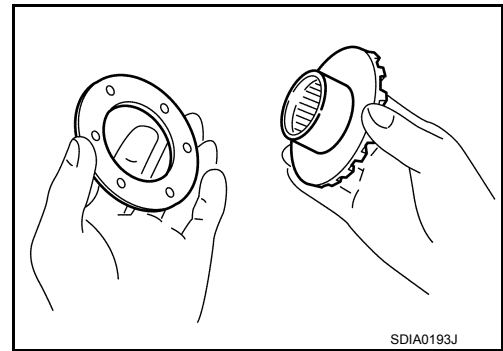

2. Install the side gears and side gear thrust washers into the differential case.
3. Install the pinion mate thrust washers to the two pinion mate gears. Then install the pinion mate gears with the pinion mate thrust washers by aligning them in diagonally opposite positions and rotating them into the differential case.

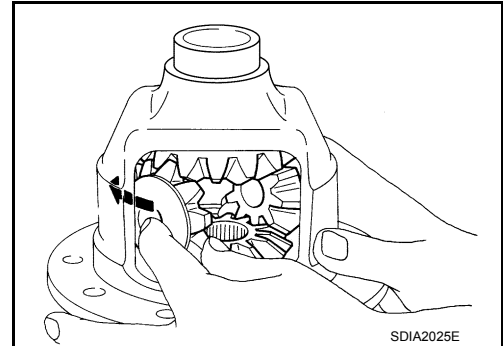

4. Install the pinion mate shaft and align the lock pin hole on the pinion mate shaft with the lock pin hole on the differential case.
5. Measure the side gear end play. If necessary, select the appropriate side gear thrust washers. Refer to [DLN-215, "Inspection and Adjustment"](#).

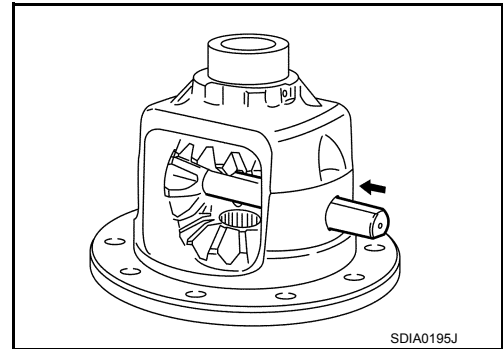

6. Drive a new lock pin into the pinion mate shaft until it is flush with the differential case using suitable tool.
CAUTION:
Do not reuse lock pin.

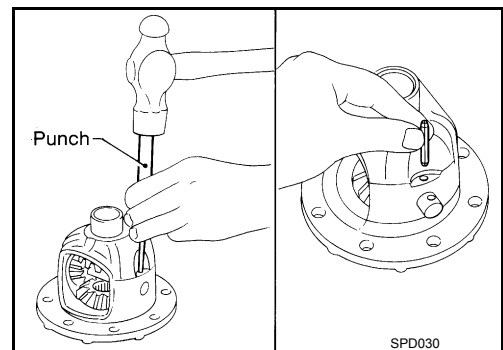

7. Align the matching mark of the differential case with the mark of the drive gear, then place the drive gear onto the differential case.

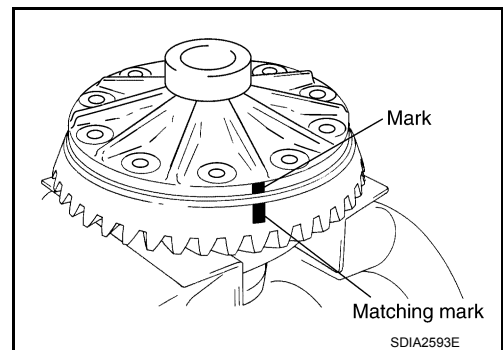

A
B
C
DLN
E
F
G
H
I
J
K
L
M
N
O
P

FRONT FINAL DRIVE

< UNIT DISASSEMBLY AND ASSEMBLY >

[FRONT FINAL DRIVE: R180A]

8. Apply thread locking sealant into the threaded holes of the drive gear and install the new drive gear bolts.
- Use Genuine High Strength Thread Locking Sealant or equivalent. Refer to [GI-22. "Recommended Chemical Products and Sealants"](#).

CAUTION:

Make sure the drive gear back and threaded holes are clean.

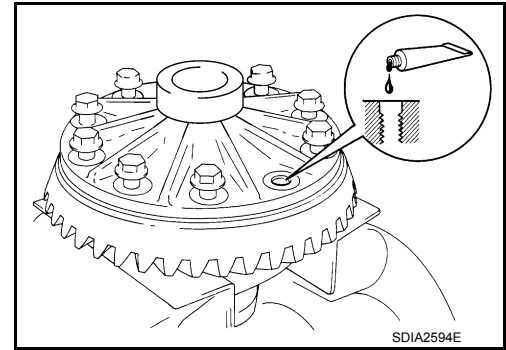

9. Tighten the new drive gear bolts to the specified torque. Refer to [DLN-196. "Disassembly and Assembly"](#). After tightening the new drive gear bolts to the specified torque, tighten an additional 34° to 39° using Tool (A).

Tool number : KV10112100-A (BT-8653-A)

CAUTION:

- Always use Tool. Avoid tightening based on visual check alone.
- Tighten new drive gear bolts in a crisscross pattern.

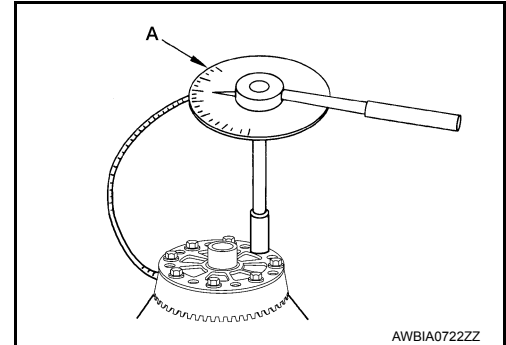

10. Press the new side bearing inner races to the differential case using Tools.

Tool number (A): ST33230000 (J-35867)

(B): ST33061000 (J-8107-2)

CAUTION:

Do not reuse side bearing inner races.

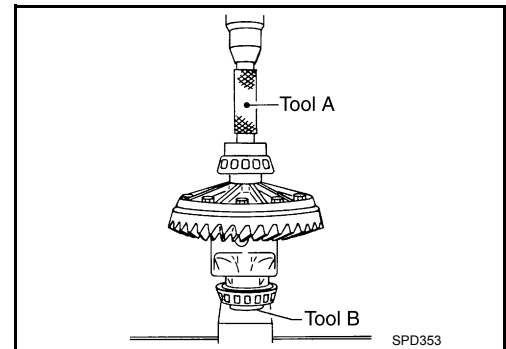

11. Install housing spacer into gear carrier.
12. Apply differential gear oil to the side bearings, and install the differential case assembly with the side bearing outer races into the gear carrier.

CAUTION:

Do not reuse side bearing outer race when replacing side bearing inner race (replace as a set).

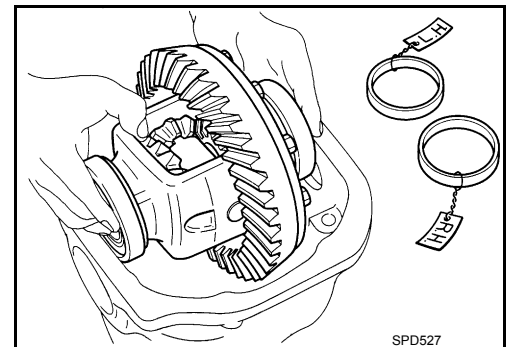

FRONT FINAL DRIVE

< UNIT DISASSEMBLY AND ASSEMBLY >

[FRONT FINAL DRIVE: R180A]

13. Insert left and right original side bearing adjusting washers in place between side bearings and gear carrier using Tool.

Tool number : KV38100600 (J-25267)

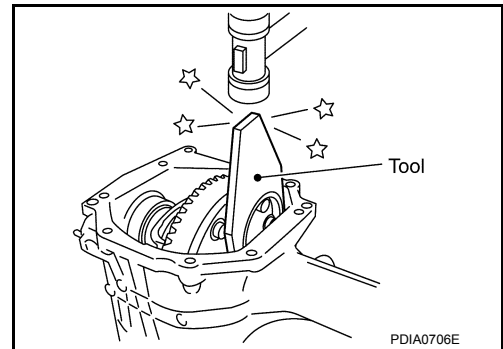

14. Install the side bearing caps with the matching marks aligned and tighten the side bearing cap bolts to the specified torque. Refer to [DLN-196](#), "Disassembly and Assembly".

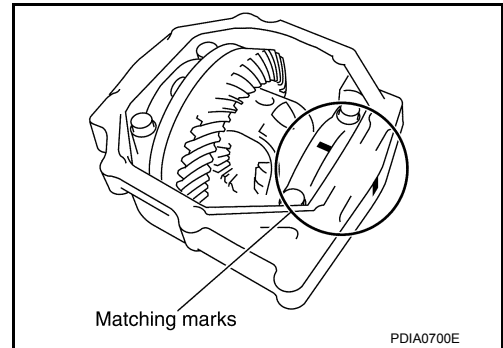

15. Apply multi-purpose grease to the lips and differential gear oil to the circumference of the new side oil seal. Then drive the new side oil seal in evenly until it becomes flush with the gear carrier using Tools.

Tool number (A): ST30720000 (J-25405)
(B): ST27863000 (—)

CAUTION:

- Do not reuse side oil seal.
- Do not incline the new side oil seal when installing.
- Apply multi-purpose grease to the lips and differential gear oil to the circumference of the new side oil seal.

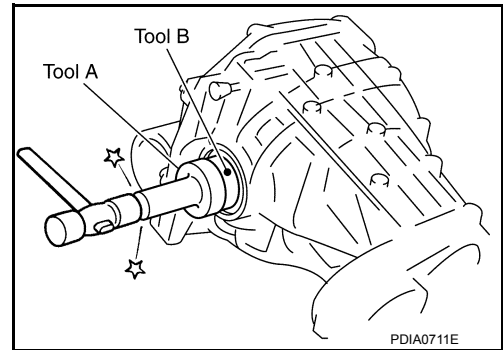

16. Check and adjust tooth contact, backlash, drive gear runout and total preload torque. Refer to [DLN-215](#), "Inspection and Adjustment".
Recheck above items.

17. Apply a 3 mm (0.12 in) bead of sealant to the mating surface of the carrier cover as shown.
• Use Genuine Silicone RTV or equivalent. Refer to [GI-22](#), "Recommended Chemical Products and Sealants".

CAUTION:

Remove any old sealant adhering to the mating surfaces. Also remove any moisture, oil, or foreign material adhering to the application and mating surfaces.

18. Install the carrier cover to the gear carrier. Tighten the bolts to the specified torque. Refer to [DLN-196](#), "Disassembly and Assembly".

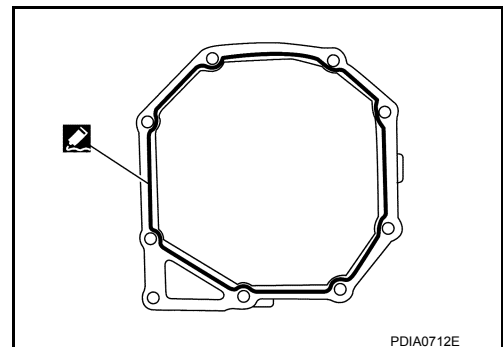

Differential side shaft

FRONT FINAL DRIVE

< UNIT DISASSEMBLY AND ASSEMBLY >

[FRONT FINAL DRIVE: R180A]

1. Press differential side shaft bearing to differential side shaft.

CAUTION:

Do not reuse differential side shaft bearing.

2. Install snap ring (differential side shaft side).
3. Install differential side shaft assembly into gear carrier.
4. Install snap ring (hole side).

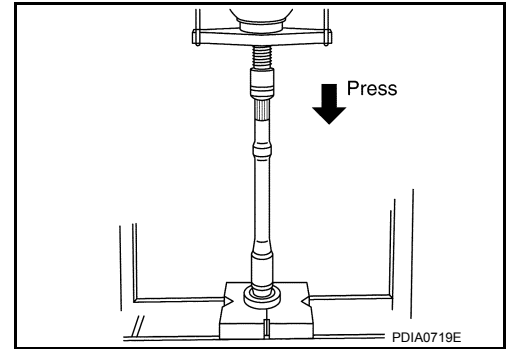

5. Apply multi-purpose grease to the lips and differential gear oil to the circumference of the new side oil seal. Then drive the new side oil seal in evenly until it becomes flush with the gear carrier using Tools.

Tool number **(A): ST30720000 (J-25405)**
 (B): ST27863000 (—)

CAUTION:

- Do not reuse side oil seal.
- Do not incline the new side oil seal when installing.
- Apply multi-purpose grease to the lips and differential gear oil to the circumference of the new side oil seal.

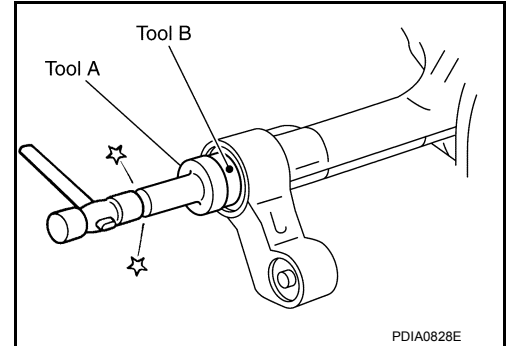

SERVICE DATA AND SPECIFICATIONS (SDS)

< SERVICE DATA AND SPECIFICATIONS (SDS)

[FRONT FINAL DRIVE: R180A]

SERVICE DATA AND SPECIFICATIONS (SDS)

SERVICE DATA AND SPECIFICATIONS (SDS)

General Specification

INFOID:000000007324001

Applied model	VQ40DE					
	4WD					
Transmission type	5A/T			6M/T		
Body type	King cab		Crew cab	King cab		Crew cab
Grade	SE, LE	Off-Road	ALL	SE	Off-Road	ALL
Final drive model	R180A					
Gear ratio	3.133	3.357		3.538	3.692	
Number of teeth (Drive gear/Drive pinion)	45/17	47/14		46/13	48/13	
Oil capacity (Approx.) ℓ (US pt, Imp pt)	0.85 (1-3/4, 1-1/2)					
Number of pinion gears	2					
Drive pinion adjustment spacer type	Collapsible					

Inspection and Adjustment

INFOID:000000007324002

DRIVE GEAR RUNOUT

Unit: mm (in)

Item	Runout limit
Drive gear back face	0.08 (0.0031) or less

SIDE GEAR CLEARANCE

Unit: mm (in)

Item	Specification
Side gear back clearance (Clearance between side gear and differential case for adjusting side gear backlash)	0.1 (0.004) or less (Each gear should rotate smoothly without excessive resistance during differential motion.)

PRELOAD TORQUE

Unit: N·m (kg·m, in·lb)

Item	Specification
Drive pinion bearing preload torque	1.08 - 1.66 (0.11 - 0.16, 10 - 14)
Side bearing preload torque	0.59 - 1.08 (0.06 - 0.11, 6 - 9)
Total preload torque (Total preload torque = drive pinion bearing preload torque + side bearing preload torque).	1.67 - 2.74 (0.17 - 0.27, 15 - 24)

BACKLASH

Unit: mm (in)

Item	Specification
Drive gear to drive pinion backlash	0.10 - 0.15 (0.0039 - 0.0059)

COMPANION FLANGE RUNOUT

Unit: mm (in)

Item	Runout limit
Companion flange face	0.1 (0.004) or less
Companion flange inner side	0.1 (0.004) or less

SERVICE DATA AND SPECIFICATIONS (SDS)

< SERVICE DATA AND SPECIFICATIONS (SDS)

[FRONT FINAL DRIVE: R180A]

SELECTIVE PARTS

Drive Pinion Height Adjusting Washer

Unit: mm (in)

Thickness	Part number*	Thickness	Part number*
3.09 (0.1217)	38154 EA000	3.39 (0.1335)	38154 EA010
3.12 (0.1228)	38154 EA001	3.42 (0.1346)	38154 EA011
3.15 (0.1240)	38154 EA002	3.45 (0.1358)	38154 EA012
3.18 (0.1252)	38154 EA003	3.48 (0.1370)	38154 EA013
3.21 (0.1264)	38154 EA004	3.51 (0.1382)	38154 EA014
3.24 (0.1276)	38154 EA005	3.54 (0.1394)	38154 EA015
3.27 (0.1287)	38154 EA006	3.57 (0.1406)	38154 EA016
3.30 (0.1299)	38154 EA007	3.60 (0.1417)	38154 EA017
3.33 (0.1311)	38154 EA008	3.63 (0.1429)	38154 EA018
3.36 (0.1323)	38154 EA009	3.66 (0.1441)	38154 EA019

*: Always check with the Parts Department for the latest parts information.

Side Gear Thrust Washer

Unit: mm (in)

Thickness	Part number*	Thickness	Part number*
0.75 (0.0295)	38424 W2010	0.87 (0.0343)	38424 W2014
0.78 (0.0307)	38424 W2011	0.90 (0.0354)	38424 W2015
0.81 (0.0319)	38424 W2012	0.93 (0.0366)	38424 W2016
0.84 (0.0331)	38424 W2013	0.96 (0.0378)	38424 W2017

*: Always check with the Parts Department for the latest parts information.

Side Bearing Adjusting Washer

Unit: mm (in)

Thickness	Part number*	Thickness	Part number*
1.95 (0.0768)	38453 EA000	2.35 (0.0925)	38453 EA008
2.00 (0.0787)	38453 EA001	2.40 (0.0945)	38453 EA009
2.05 (0.0807)	38453 EA002	2.45 (0.0965)	38453 EA010
2.10 (0.0827)	38453 EA003	2.50 (0.0984)	38453 EA011
2.15 (0.0846)	38453 EA004	2.55 (0.1004)	38453 EA012
2.20 (0.0866)	38453 EA005	2.60 (0.1024)	38453 EA013
2.25 (0.0886)	38453 EA006	2.65 (0.1043)	38453 EA014
2.30 (0.0906)	38453 EA007		

*: Always check with the Parts Department for the latest parts information.

PRECAUTION

PRECAUTIONS

Precaution for Supplemental Restraint System (SRS) "AIR BAG" and "SEAT BELT PRE-TENSIONER"

INFOID:000000007324003

The Supplemental Restraint System such as "AIR BAG" and "SEAT BELT PRE-TENSIONER", used along with a front seat belt, helps to reduce the risk or severity of injury to the driver and front passenger for certain types of collision. This system includes seat belt switch inputs and dual stage front air bag modules. The SRS system uses the seat belt switches to determine the front air bag deployment, and may only deploy one front air bag, depending on the severity of a collision and whether the front occupants are belted or unbelted. Information necessary to service the system safely is included in the SR and SB section of this Service Manual.

WARNING:

- To avoid rendering the SRS inoperative, which could increase the risk of personal injury or death in the event of a collision which would result in air bag inflation, all maintenance must be performed by an authorized NISSAN/INFINITI dealer.
- Improper maintenance, including incorrect removal and installation of the SRS, can lead to personal injury caused by unintentional activation of the system. For removal of Spiral Cable and Air Bag Module, see the SR section.
- Do not use electrical test equipment on any circuit related to the SRS unless instructed to in this Service Manual. SRS wiring harnesses can be identified by yellow and/or orange harnesses or harness connectors.

PRECAUTIONS WHEN USING POWER TOOLS (AIR OR ELECTRIC) AND HAMMERS

WARNING:

- When working near the Airbag Diagnosis Sensor Unit or other Airbag System sensors with the Ignition ON or engine running, DO NOT use air or electric power tools or strike near the sensor(s) with a hammer. Heavy vibration could activate the sensor(s) and deploy the air bag(s), possibly causing serious injury.
- When using air or electric power tools or hammers, always switch the Ignition OFF, disconnect the battery, and wait at least 3 minutes before performing any service.

Precaution for Servicing Rear Final Drive

INFOID:000000007324004

- Before starting diagnosis of the vehicle, understand the symptoms well. Perform correct and systematic operations.
- Check for the correct installation status prior to removal or disassembly. When matching marks are required, be certain they do not interfere with the function of the parts they are applied to.
- Overhaul should be done in a clean work area, a dust proof area is recommended.
- Before disassembly, completely remove sand and mud from the exterior of the unit, preventing them from entering into the unit during disassembly or assembly.
- Always use shop paper for cleaning the inside of components.
- Avoid using cotton gloves or a shop cloth to prevent the entering of lint.
- Check appearance of the disassembled parts for damage, deformation, and abnormal wear. Replace them with new ones if necessary.
- Gaskets, seals and O-rings should be replaced any time the unit is disassembled.
- Clean and flush the parts sufficiently and blow them dry.
- Be careful not to damage sliding surfaces and mating surfaces.
- When applying sealant, remove the old sealant from the mating surface; then remove any moisture, oil, and foreign materials from the application and mating surfaces.
- In principle, tighten nuts or bolts gradually in several steps working diagonally from inside to outside. If a tightening sequence is specified, observe it.
- During assembly, observe the specified tightening torque.
- Add new differential gear oil, petroleum jelly, or multi-purpose grease, as specified.

A
B
C
DLN
E
F
G
H
I
J
K
L
M
N
O
P

PREPARATION

[C200]

< PREPARATION >

PREPARATION

PREPARATION

Special Service Tool

INFOID:000000007324005

The actual shapes of Kent-Moore tools may differ from those of special service tools illustrated here.

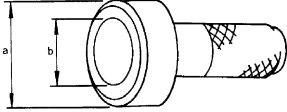
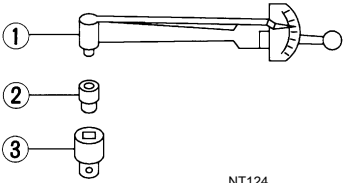
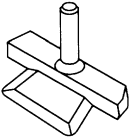
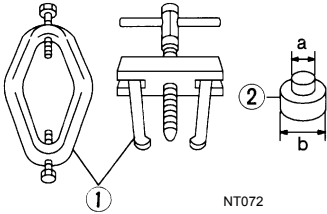
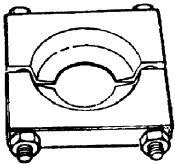
Tool number (Kent-Moore No.) Tool name	Description
KV38100500 (J-25273) Drift	Installing front oil seal a: 80 mm (3.15 in) dia. b: 60 mm (2.36 in) dia.
 <p style="text-align: center;">ZZA0811D</p>	
ST3127S000 (J-25765-A) Preload gauge 1: GG91030000 (J-25765) Torque wrench 2: HT62940000 (—) Socket adapter (1/2") 3: HT62900000 (—) Socket adapter (3/8")	Measuring drive pinion bearing preload torque and total preload torque
 <p style="text-align: center;">NT124</p>	
KV10111100 (J-37228) Seal cutter	Removing carrier cover
 <p style="text-align: center;">S-NT046</p>	
ST3306S001 (—) Differential side bearing puller set 1: ST33051001 (J-22888-20) Puller 2: ST33061000 (J-8107-2) Base	Removing and installing side bearing inner race a: 28.5 mm (1.122 in) dia. b: 38 mm (1.50 in) dia.
 <p style="text-align: center;">NT072</p>	
ST30031000 (J-22912-01) Puller	Removing drive pinion rear bearing inner race
 <p style="text-align: center;">ZZA0700D</p>	

PREPARATION

< PREPARATION >

[C200]

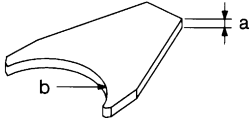
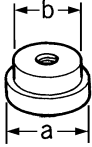
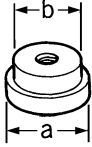
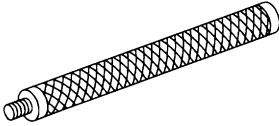
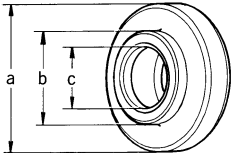
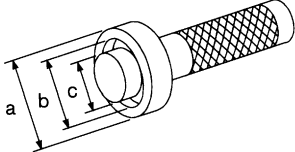
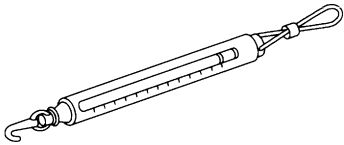
Tool number (Kent-Moore No.) Tool name	Description	
KV38100600 (J-25267) Drift		A B C
ST30621000 (J-25742-5) Drift		DLN E F
ST30613000 (J-25742-3) Drift		G H
ST30611000 (J-25742-1) Drift bar		I J K
ST30901000 (J-26010-01) Drift		L M
ST3323 0000 (J-25805-01) Drift		N O
— (J-8129) Spring gauge		P

PREPARATION

< PREPARATION >

[C200]

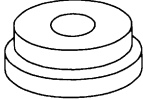
Tool number (Kent-Moore No.) Tool name	Description
— (J-34309) Differential shim selector tool	Adjusting bearing preload and pinion gear height
 NT134	
— (J-25269-4) Side bearing disc (2 Req'd)	Selecting pinion height adjusting washer
 NT136	

Commercial Service Tool

INFOID:000000007324006

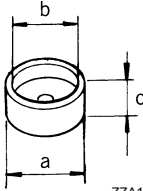
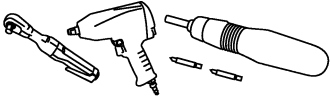
Tool name	Description
Spacer	Installing pinion front bearing inner race a: 60 mm (2.36 in) dia. b: 36 mm (1.42 in) dia. c: 30 mm (1.18 in)
 ZZA1133D	
Power tool	Loosening nuts, screws and bolts
 PIIB1407E	

NOISE, VIBRATION AND HARSHNESS (NVH) TROUBLESHOOTING

[C200]

< SYSTEM DESCRIPTION >

SYSTEM DESCRIPTION

NOISE, VIBRATION AND HARSHNESS (NVH) TROUBLESHOOTING

NVH Troubleshooting Chart

INFOID:000000007324007

Use the chart below to help you find the cause of the symptom. If necessary, repair or replace these parts.

Symptom	Noise	Reference page
Gear tooth rough	x	DLN-228, "Disassembly and Assembly"
Gear contact improper	x	DLN-228, "Disassembly and Assembly"
Tooth surfaces worn	x	DLN-228, "Disassembly and Assembly"
Backlash incorrect	x	DLN-228, "Disassembly and Assembly"
Companion flange excessive runout	x	DLN-228, "Disassembly and Assembly"
Gear oil improper	x	MA-18, "FOR USA AND CANADA : Fluids and Lubricants" (United States and Canada) or MA-20, "FOR MEXICO : Fluids and Lubricants" (Mexico) .
PROPELLER SHAFT	x	DLN-175, "NVH Troubleshooting Chart"
REAR AXLE		DLN-175, "NVH Troubleshooting Chart"
REAR SUSPENSION	x	RAX-17, "NVH Troubleshooting Chart"
TIRES	x	WT-43, "NVH Troubleshooting Chart"
ROAD WHEEL	x	WT-43, "NVH Troubleshooting Chart"
DRIVE SHAFT	x	FAX-4, "NVH Troubleshooting Chart"
BRAKES	x	BR-5, "NVH Troubleshooting Chart"
STEERING	x	ST-5, "NVH Troubleshooting Chart"

x: Applicable

A
B
C
DLN
E
F
G
H
I
J
K
L
M
N
O
P

DESCRIPTION

< SYSTEM DESCRIPTION >

[C200]

DESCRIPTION

Cross-Sectional View

INFOID:000000007324008

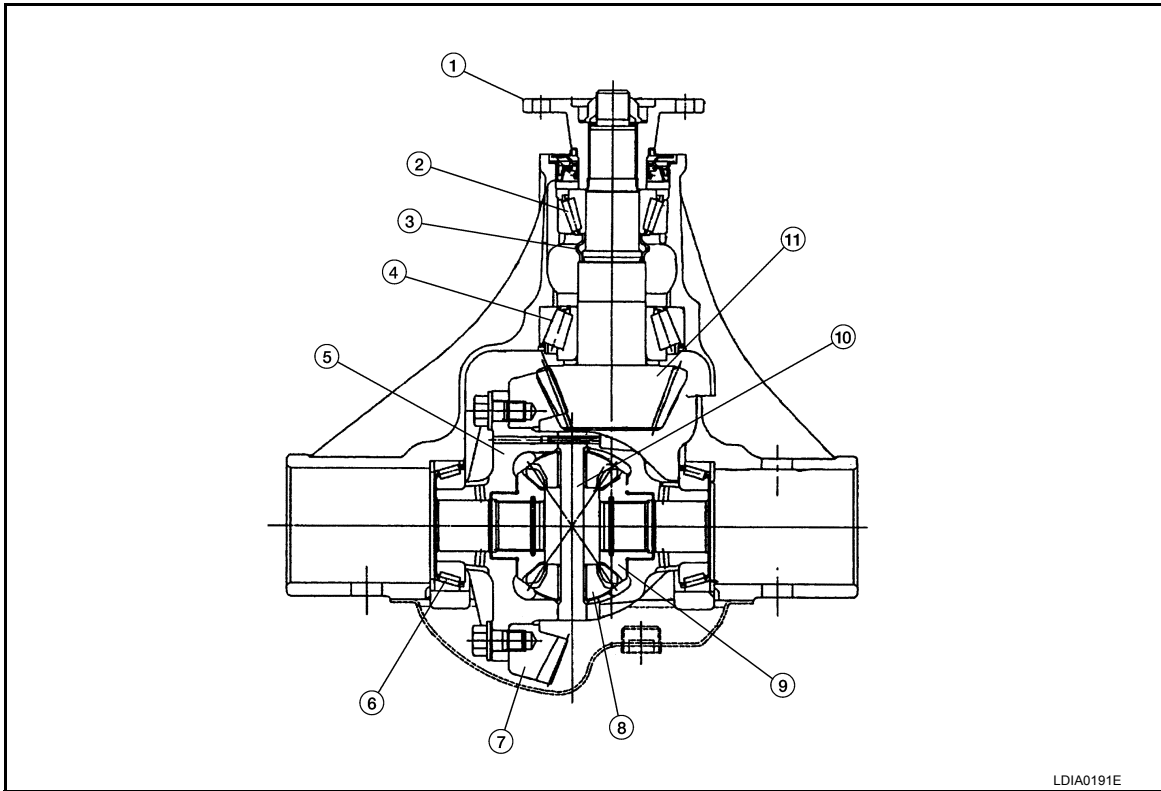

- | | | |
|------------------------|-------------------------|-----------------------|
| 1. Companion flange | 2. Pinion front bearing | 3. Collapsible spacer |
| 4. Pinion rear bearing | 5. Differential case | 6. Side bearing |
| 7. Drive gear | 8. Pinion mate gear | 9. Side gear |
| 10. Pinion mate shaft | 11. Drive pinion | |

PERIODIC MAINTENANCE

DIFFERENTIAL GEAR OIL

Changing Differential Gear Oil

INFOID:000000007324009

DRAINING

1. Stop engine.
2. Remove the drain plug from the rear final drive assembly to drain the differential gear oil.
3. Install the drain plug with a new gasket to the rear final drive assembly. Tighten to the specified torque. Refer to [DLN-228, "Disassembly and Assembly"](#).

CAUTION:

Do not reuse gasket.

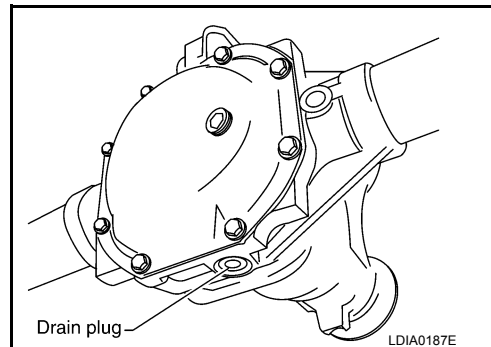

FILLING

1. Remove the filler plug from the rear final drive assembly.
2. Fill the rear final drive assembly with new differential gear oil until the level reaches the specified level near the filler plug hole.

Differential gear oil grade and capacity

: Refer to [MA-18, "FOR USA AND CANADA : Fluids and Lubricants"](#) (United States and Canada) and [MA-20, "FOR MEXICO : Fluids and Lubricants"](#) (Mexico).

3. Install the filler plug with sealant applied on the threads to the rear final drive assembly. Tighten to the specified torque. Refer to [DLN-228, "Disassembly and Assembly"](#).
 - Use High Performance Thread Sealant or equivalent. Refer to [GI-22, "Recommended Chemical Products and Sealants"](#).

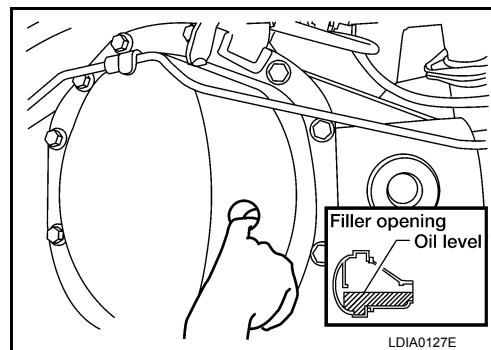

Checking Differential Gear Oil

INFOID:000000007324010

DIFFERENTIAL GEAR OIL LEAKAGE AND LEVEL

1. Make sure that differential gear oil is not leaking from the rear final drive assembly or around it.
2. Check the differential gear oil level from the filler plug hole as shown.

CAUTION:

Do not start engine while checking differential gear oil level.

3. Install the filler plug with sealant applied on the threads to the rear final drive assembly. Tighten to the specified torque. Refer to [DLN-228, "Disassembly and Assembly"](#).
 - Use High Performance Thread Sealant or equivalent. Refer to [GI-22, "Recommended Chemical Products and Sealants"](#).

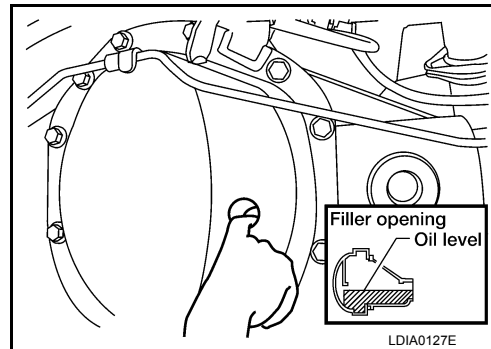

A
B
C
DLN
E
F
G
H
I
J
K
L
M
N
O
P

REMOVAL AND INSTALLATION

FRONT OIL SEAL

Removal and Installation

INFOID:000000007324011

REMOVAL

1. Remove the propeller shaft. Refer to [DLN-146, "Removal and Installation" \(2S1330\)](#), [DLN-155, "Removal and Installation" \(3S1310\)](#), [DLN-166, "Removal and Installation" \(3S1330\)](#) or [DLN-177, "Removal and Installation" \(3S1330-2BJ100\)](#).

2. Put matching mark on the end of the drive pinion. The matching mark should be in line with the matching mark A on companion flange.

CAUTION:

For matching mark, use paint. Do not damage drive pinion.

NOTE:

The matching mark (A) on the final drive companion flange indicates the maximum vertical runout position.

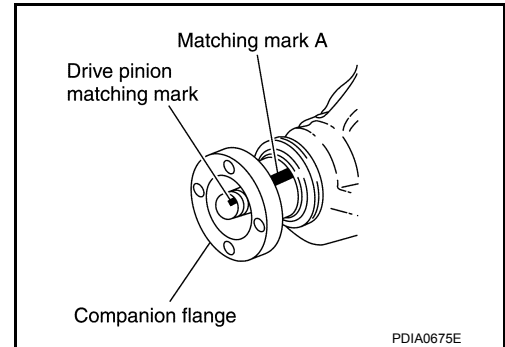

3. Remove the drive pinion lock nut using suitable tool.

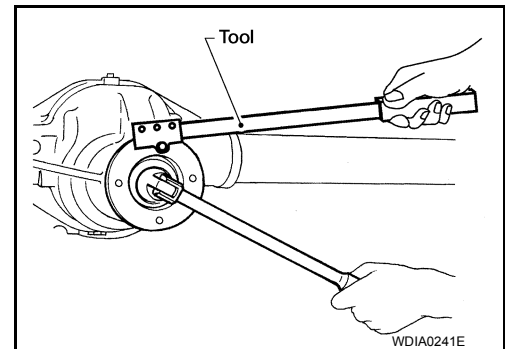

4. Remove the companion flange using suitable tool.

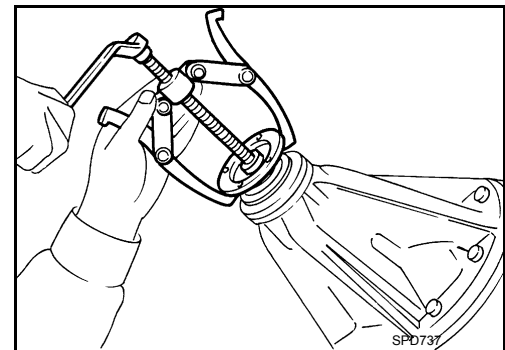

5. Remove the front oil seal using suitable tool.

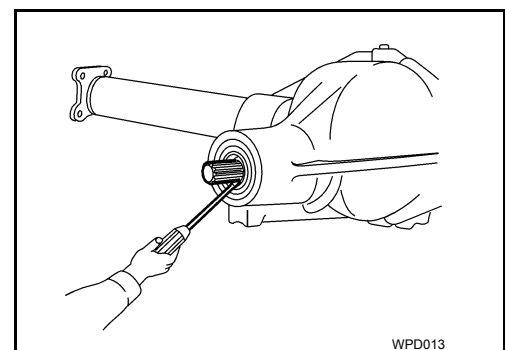

FRONT OIL SEAL

[C200]

< REMOVAL AND INSTALLATION >

INSTALLATION

1. Apply multi-purpose grease to the front oil seal lips.
2. Install the new front oil seal using Tool.

Tool number : KV38100500 (J-25273)

CAUTION:

- Do not reuse oil seal.
- Do not incline oil seal when installing.

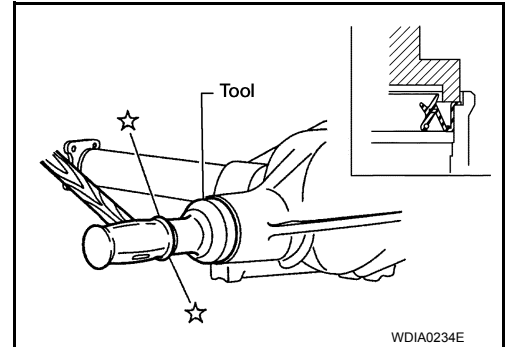

3. Align the matching mark of drive pinion with the matching mark (A) of companion flange, then install the companion flange.

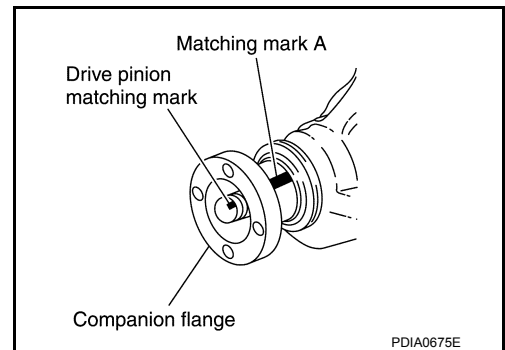

4. Apply gear oil on the screw part of drive pinion and the seating surface of drive pinion lock nut.
5. Install the new drive pinion lock nut and tighten to the specified torque using suitable tool. Refer to [DLN-228, "Disassembly and Assembly"](#).

CAUTION:

Do not reuse drive pinion lock nut.

6. Install the propeller shaft. Refer to [DLN-146, "Removal and Installation"](#) (2S1330), [DLN-155, "Removal and Installation"](#) (3S1310), [DLN-166, "Removal and Installation"](#) (3S1330) or [DLN-177, "Removal and Installation"](#) (3S1330-2BJ100).

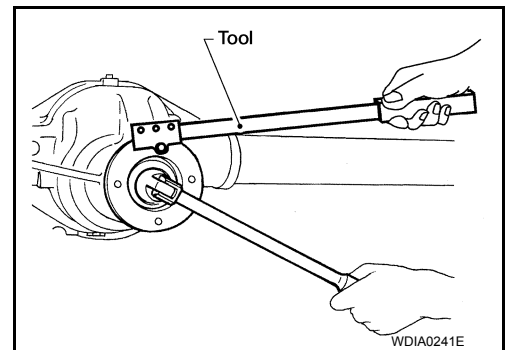

A
B
C
DLN
E
F
G
H
I
J
K
L
M
N
O
P

CARRIER COVER

< REMOVAL AND INSTALLATION >

[C200]

CARRIER COVER

Removal and Installation

INFOID:000000007324012

REMOVAL

1. Drain the differential gear oil. Refer to [DLN-223, "Changing Differential Gear Oil"](#).
2. Disconnect the parking brake cable and brake tube from the carrier cover.
3. Remove the carrier cover bolts and separate the carrier cover from the gear carrier using Tool.

Tool number : KV10111100 (J-37228)

CAUTION:

- Do not damage the mating surface.
- Do not insert flat-bladed screwdriver, this will damage the mating surface.

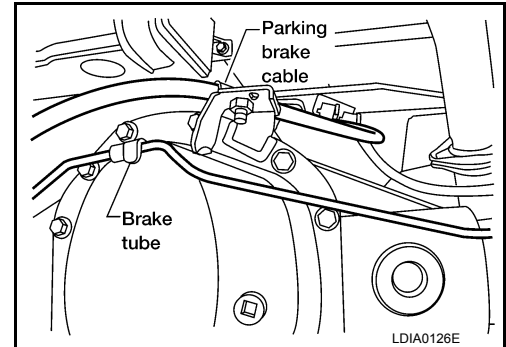

INSTALLATION

1. Apply a bead of sealant to the mating surface of the carrier cover as shown.
 - Use Genuine Silicone RTV or equivalent. Refer to [GI-22, "Recommended Chemical Products and Sealants"](#).
2. Install the carrier cover to the gear carrier. Tighten the bolts to the specified torque. Refer to [DLN-228, "Disassembly and Assembly"](#).
3. Connect the parking brake cable and brake tube to the carrier cover.
4. Fill the rear final drive assembly with recommended differential gear oil. Refer to [DLN-223, "Checking Differential Gear Oil"](#).

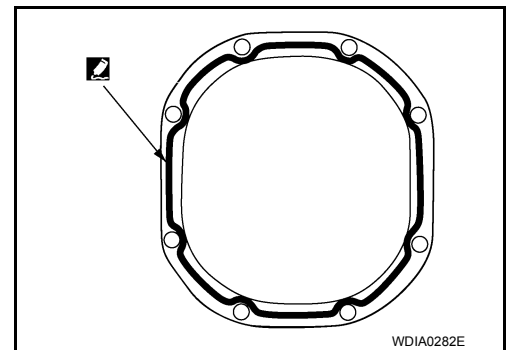

UNIT REMOVAL AND INSTALLATION

REAR FINAL DRIVE

Removal and Installation

INFOID:000000007324013

REMOVAL

CAUTION:

- Do not damage spline, companion flange and front oil seal when removing propeller shaft.
- Before removing final drive assembly or rear axle assembly, disconnect ABS sensor harness connector from the assembly and move it away from final drive/rear axle assembly area. Failure to do so may result in sensor wires being damaged and sensor becoming inoperative.

1. Remove the rear disc brake rotors. Refer to [BR-40, "Removal and Installation of Brake Caliper and Disc Rotor"](#).
2. Remove the rear propeller shaft. Refer to [DLN-146, "Removal and Installation"](#) (2S1330), [DLN-155, "Removal and Installation"](#) (3S1310), [DLN-166, "Removal and Installation"](#) (3S1330) or [DLN-177, "Removal and Installation"](#) (2S1330-BJ100).
3. Disconnect the following components from the rear final drive.
 - ABS sensor wire harness
 - Parking brake cable
 - Brake hoses and tubes

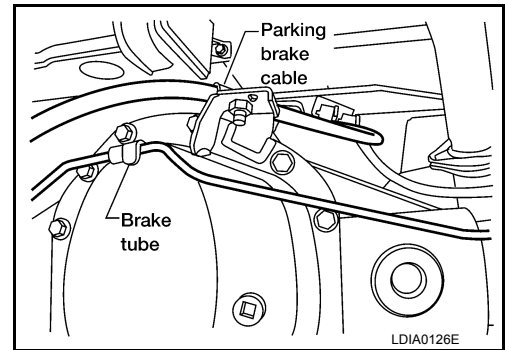

4. Support rear final drive assembly using a suitable jack.
5. Remove rear shock absorber lower bolts. Refer to [FSU-14, "Removal and Installation"](#).
6. Remove leaf spring U-bolt nuts. Refer to [RSU-9, "Removal and Installation"](#).
7. Remove rear final drive assembly

CAUTION:

Secure rear final drive assembly to the jack while removing it.

INSTALLATION

Installation is in the reverse order of removal.

CAUTION:

Check the rear final drive assembly differential gear oil and refill as necessary. Check for fluid leaks. Refer to [DLN-223, "Checking Differential Gear Oil"](#).

REAR FINAL DRIVE

< UNIT DISASSEMBLY AND ASSEMBLY >

[C200]

- | | | |
|--|-------------------------------|------------------------------|
| 1. Gear carrier | 2. Drive pinion lock nut | 3. Companion flange |
| 4. Front oil seal | 5. Drive pinion front bearing | 6. Drain plug |
| 7. Collapsible spacer | 8. Side bearing cap | 9. Drive pinion rear bearing |
| 10. Drive pinion height adjusting washer | 11. Drive pinion | 12. Drive gear |
| 13. Differential case | 14. Carrier cover | 15. Filler plug |
| 16. Pinion mate shaft | 17. Lock pin | 18. Side bearing |
| 19. Side bearing adjusting washer | 20. Side gear thrust washer | 21. Side gear |
| 22. Pinion mate gear | 23. Pinion mate thrust washer | 24. Gasket |
| 25. Breather | | |

A

B

C

DLN

ASSEMBLY INSPECTION AND ADJUSTMENT

- Drain the differential gear oil before inspection and adjustment. Refer to [DLN-223, "Changing Differential Gear Oil"](#).
- Remove and install the carrier cover as necessary for inspection and adjustment. Refer to [DLN-226, "Removal and Installation"](#).

E

Total Preload Torque

1. Rotate drive pinion back and forth 2 to 3 times to check for unusual noise and rotation malfunction.
2. Rotate drive pinion at least 20 times to check for smooth operation of the bearing.
3. Measure total preload torque using Tool.

F

Tool number : ST3127S000 (J-25765-A)

Total preload torque

: Refer to [DLN-247, "Inspection and Adjustment"](#)

NOTE:

Total preload torque = Drive pinion bearing preload torque + Side bearing preload torque

- If the measured value is out of the specification, check and adjust each part. Adjust the drive pinion bearing preload torque first, then adjust the side bearing preload torque.

G

H

I

J

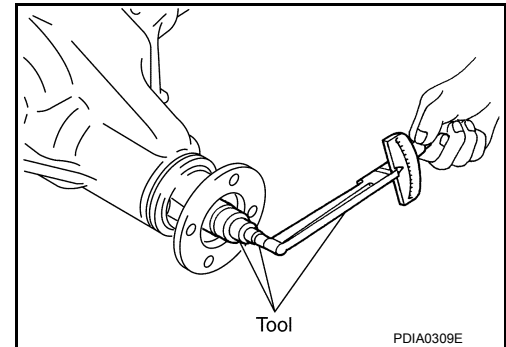

K

If the total preload torque is greater than specification

On drive pinion bearings: Replace the collapsible spacer.

On side bearings: Use thinner side bearing adjusting washers by the same amount to each side. Refer to [DLN-247, "Inspection and Adjustment"](#).

L

M

If the total preload torque is less than specification

On drive pinion bearings: Tighten the drive pinion nut.

On side bearings: Use thicker side bearing adjusting washers by the same amount to each side. Refer to [DLN-247, "Inspection and Adjustment"](#).

N

O

Drive Gear Runout

P

REAR FINAL DRIVE

[C200]

< UNIT DISASSEMBLY AND ASSEMBLY >

1. Fit a dial indicator to the drive gear back face.
2. Rotate the drive gear to measure runout.

Runout limit : Refer to [DLN-247, "Inspection and Adjustment"](#)

- If the runout is outside of the limit, check the condition of the drive gear assembly. Foreign material may be caught between the drive gear and differential case, or the differential case or drive gear may be deformed.

CAUTION:

Replace drive gear and drive pinion as a set.

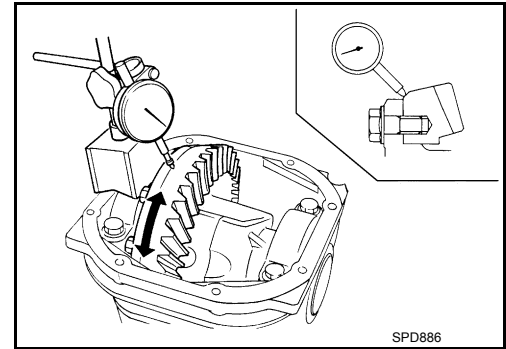

Tooth Contact

Checking gear tooth contact pattern is necessary to verify correct relationship between drive gear and drive pinion. Gears which are not positioned in proper arrangement may be noisy and/or have a short life. Check gear tooth contact pattern to obtain the best contact for low noise and long life.

1. Apply red lead to drive gear.

NOTE:

Apply red lead to both faces of three to four gears, at four locations evenly spaced on the drive gear.

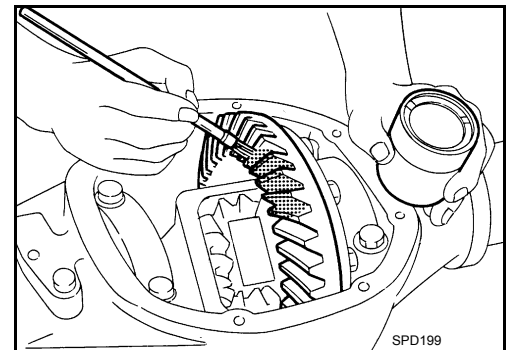

2. Rotate the drive gear back and forth several times. Then check for correct drive pinion to drive gear tooth contact as shown.

CAUTION:

Check tooth contact on drive side and reverse side.

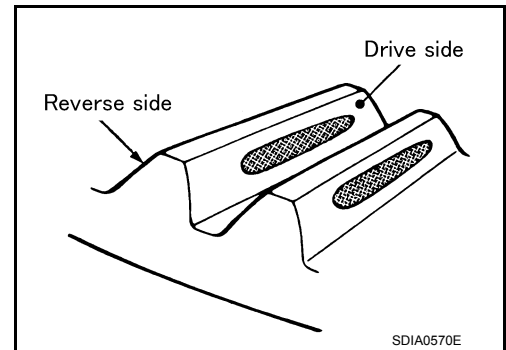

3. If the tooth contact is improperly adjusted, follow the procedure below to adjust the pinion height (dimension X).

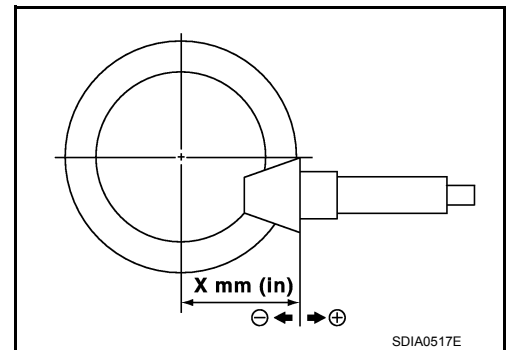

REAR FINAL DRIVE

[C200]

< UNIT DISASSEMBLY AND ASSEMBLY >

- If the tooth contact is near the face (face contact), or near the heel (heel contact), use a thicker drive pinion height adjusting washers to move the drive pinion closer to the drive gear. Refer to [DLN-247, "Inspection and Adjustment"](#).

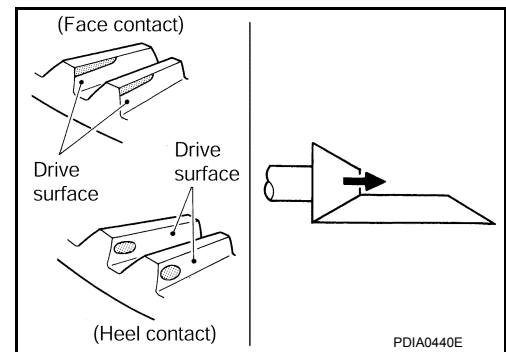

- If the tooth contact is near the flank (flank contact), or near the toe (toe contact), use a thinner drive pinion height adjusting washers to move the drive pinion farther from the drive gear. Refer to [DLN-247, "Inspection and Adjustment"](#).

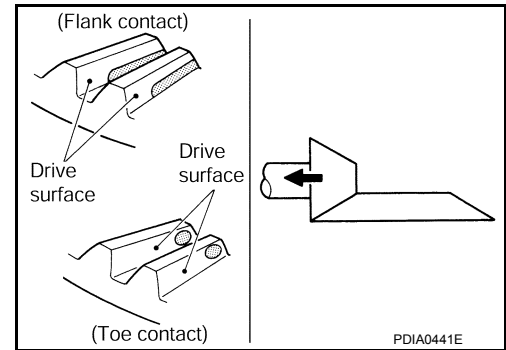

Backlash

1. Fit a dial indicator to the drive gear face to measure the backlash.

Backlash: Refer to [DLN-247, "Inspection and Adjustment"](#)

- If the backlash is outside of the specification, change the thickness of each side bearing adjusting washer.

If the backlash is greater than specification:

Make drive gear back side adjusting washer thicker, and drive gear tooth side adjusting washer thinner by the same amount. Refer to [DLN-247, "Inspection and Adjustment"](#).

If the backlash is less than specification:

Make drive gear back side adjusting washer thinner, and drive gear tooth side adjusting washer thicker by the same amount. Refer to [DLN-247, "Inspection and Adjustment"](#).

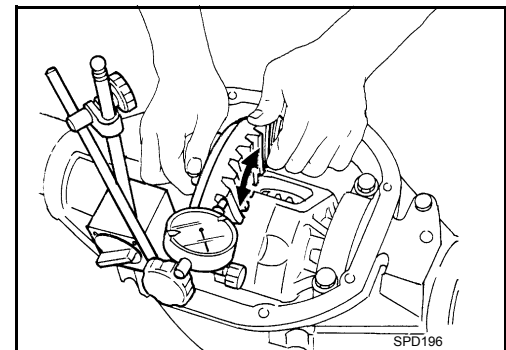

CAUTION:

Do not change the total thickness of side bearing adjusting washers as it will change the side bearing preload torque.

Companion Flange Runout

A
B
C
DLN
E
F
G
H
I
J
K
L
M
N
O
P

REAR FINAL DRIVE

[C200]

< UNIT DISASSEMBLY AND ASSEMBLY >

1. Rotate companion flange and check for runout on the companion flange face (inner side of the bolt holes) and companion flange inner side (socket diameter) using suitable tool.

Runout limit: Refer to [DLN-247, "Inspection and Adjustment"](#)

2. If the runout is outside the runout limit, follow the procedure below to adjust.
 - a. Rotate the companion flange on the drive pinion by 90°, 180° and 270° while checking for the position where the runout is minimum.
 - b. If the runout is still outside of the runout limit after the companion flange has been rotated on the drive pinion, possible cause could be an assembly malfunction of drive pinion and drive pinion bearing or a malfunctioning drive pinion bearing.
 - c. If the runout is still outside of the runout limit after repair of the assembly of drive pinion and drive pinion bearing or drive pinion bearing, replace the companion flange.

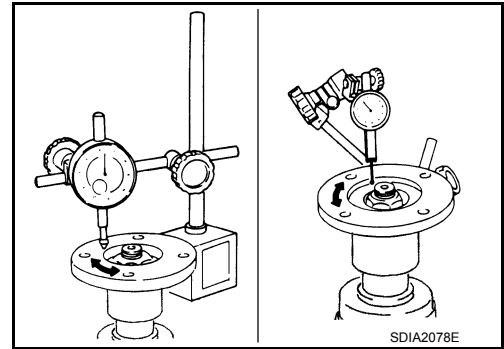

DISASSEMBLY

Differential Assembly

1. Remove carrier cover bolts.
2. Remove carrier cover using Tool.

Tool number : KV10111100 (J-37228)

CAUTION:

- Do not damage the mating surface.
- Do not insert flat-bladed screwdriver, this will damage the mating surface.

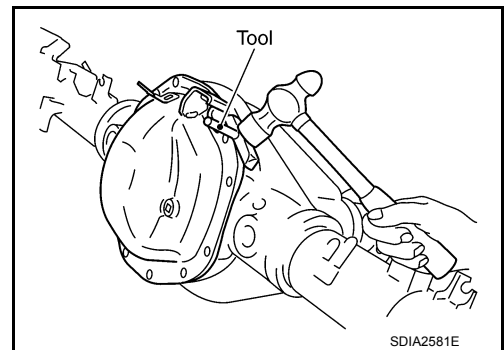

3. For proper reinstallation, paint matching marks on one side of side bearing cap.

CAUTION:

- Side bearing caps are line-board for initial assembly. The matching marks are used to reinstall them in their original positions.
- For matching mark, use paint. Do not damage side bearing cap.

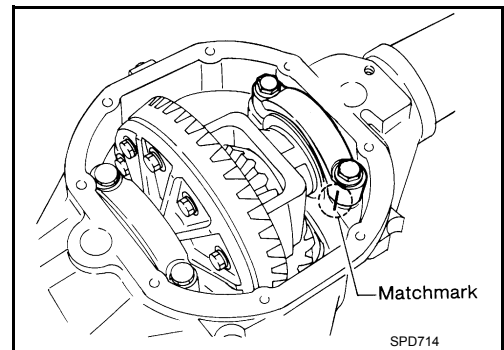

4. Remove side bearing caps.

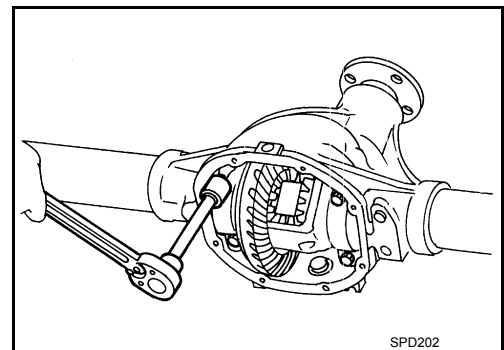

REAR FINAL DRIVE

< UNIT DISASSEMBLY AND ASSEMBLY >

[C200]

5. Remove differential case assembly using suitable tool.

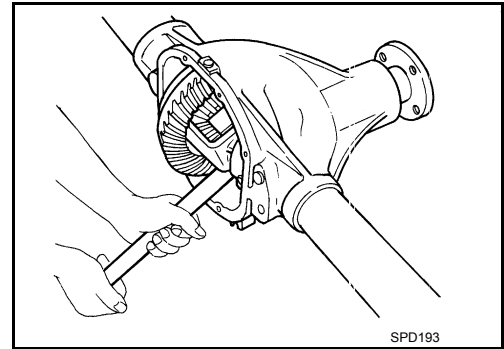

- Keep side bearing outer races together with inner races. Do not mix them up. Also, keep side bearing adjusting washers together with bearings.

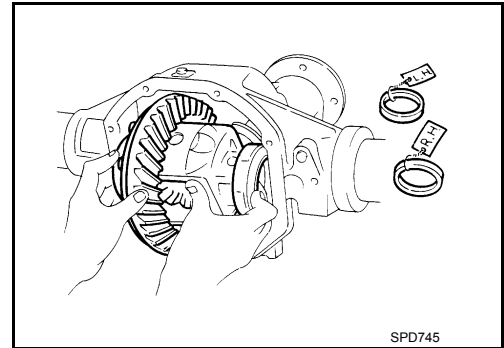

6. Remove side bearing inner race using Tools.

Tool number (A): ST33051001 (J-22888-20)

(B): ST33061000 (J-8107-2)

CAUTION:

- Engage puller jaws in groove to prevent damage.
- To prevent damage to the side bearing and drive gear, place copper plates between these parts and vise.
- It is not necessary to remove side bearing inner race except if it is replaced.

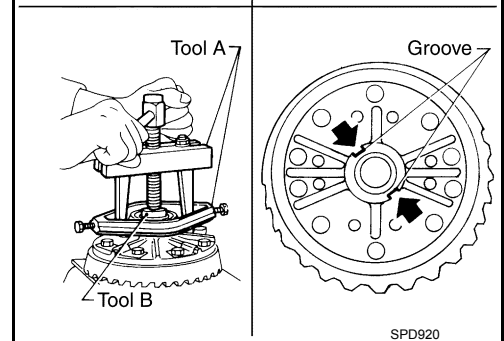
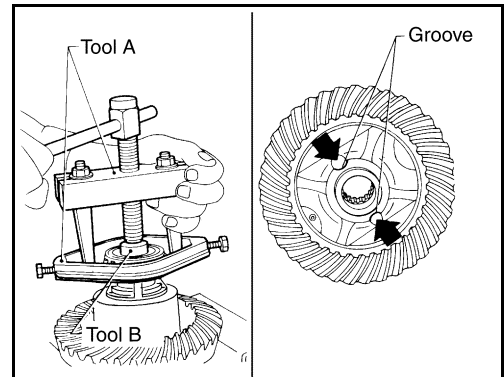

7. For proper reinstallation, paint matching mark on one differential case assembly.

CAUTION:

Use paint for matching marks. Do not damage differential case or drive gear.

8. Remove drive gear bolts.

9. Tap the drive gear off the differential case assembly using suitable tool.

CAUTION:

Tap evenly all around to keep drive gear from binding.

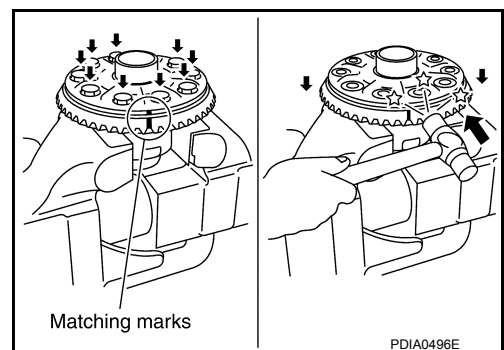

A
B
C
DLN
E
F
G
H
I
J
K
L
M
N
O
P

REAR FINAL DRIVE

< UNIT DISASSEMBLY AND ASSEMBLY >

[C200]

10. Remove the lock pin of pinion mate shaft from the drive gear side using suitable tool.

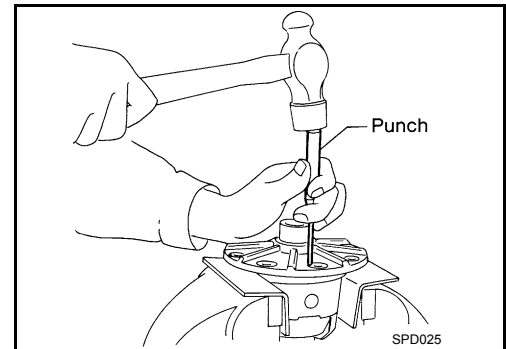

11. Remove pinion mate shaft.

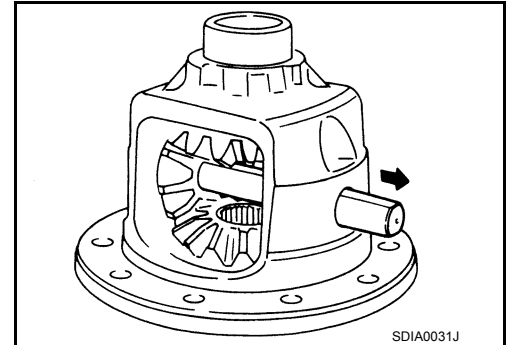

12. Turn the pinion mate gear, then remove the pinion mate gear, pinion mate thrust washer, side gear and side gear thrust washer from differential case.

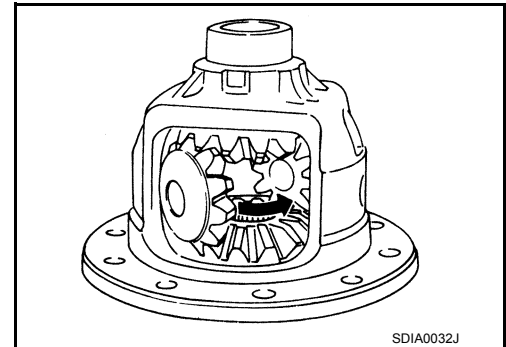

Drive Pinion Assembly

1. Remove differential case assembly. Refer to [DLN-228, "Disassembly and Assembly"](#).
2. Remove drive pinion lock nut using suitable tool.
3. Put matching marks on the companion flange and drive pinion using paint.

CAUTION:

Use paint to make the matching marks. Do not damage the companion flange or drive pinion.

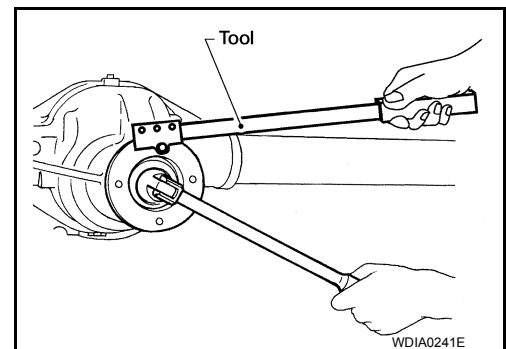

REAR FINAL DRIVE

< UNIT DISASSEMBLY AND ASSEMBLY >

[C200]

4. Remove companion flange using suitable Tool.

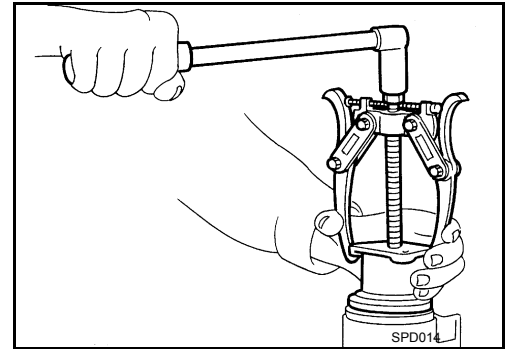

5. Remove drive pinion assembly from gear carrier using suitable tool.

CAUTION:

Do not drop drive pinion assembly.

6. Remove front oil seal.
7. Remove drive pinion front bearing inner race.
8. Remove collapsible spacer.

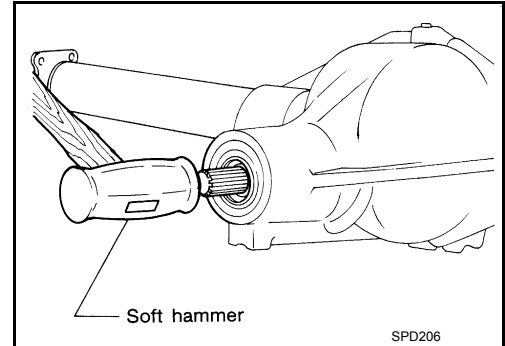

9. Remove drive pinion rear bearing inner race and drive pinion height adjusting washer using Tool.

Tool number : ST30031000 (J-22912-01)

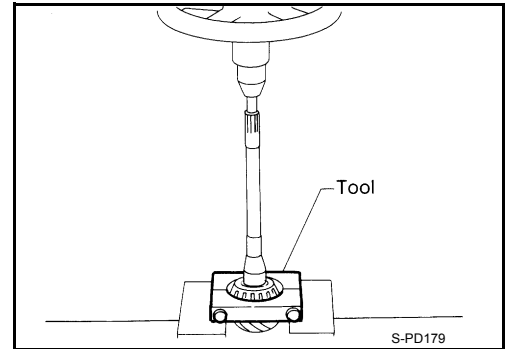

10. Tap drive pinion front and rear bearing outer races uniformly with a brass bar or equivalent to remove.

CAUTION:

Do not damage gear carrier.

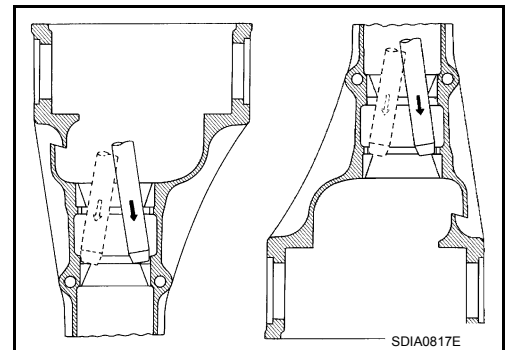

INSPECTION AFTER DISASSEMBLY

Clean up the disassembled parts. Then, inspect if the parts are worn or damaged. If so, follow the measures below.

Drive Pinion and Drive Gear

- If the drive pinion and drive gear teeth do not mesh or line-up correctly, determine the cause and adjust, repair, or replace as necessary.
- If the drive pinion or drive gear are worn, cracked, damaged, pitted or chipped (by friction) noticeably, replace with new drive pinion and drive gear.
- Drive pinion and drive gear are supplied in matched sets only. Matching numbers on both drive pinion and drive gear are etched for verification. If a new drive pinion and drive gear set are being used, verify the numbers of each drive pinion and drive gear before proceeding with assembly.

A
B
C
DLN
E
F
G
H
I
J
K
L
M
N
O
P

REAR FINAL DRIVE

< UNIT DISASSEMBLY AND ASSEMBLY >

[C200]

Bearing

- If bearings are chipped (by friction), pitted, worn, rusted, scratched, or unusual noise is coming from bearing, replace with new bearing assembly (as a new set).
- Bearing must be replaced with a new one whenever disassembled.

Side Gear and Pinion Mate Gear

- If any cracks or damage are found on the surface of the teeth, replace with new one.
- If any worn or chipped marks are found on the side of the side gear and pinion mate gear which contact the thrust washer, replace with new one.
- Replace both side gear and pinion mate gear as a set when replacing side gear or pinion mate gear.

Side Gear Thrust Washer and Pinion Mate Thrust Washer

- If any chips (by friction), damage, or unusual wear are found, replace with new one.

Gear Carrier

- If any wear or cracks are found on the contact sides of gear carrier, replace with new one.

Companion Flange

- If any chips (about 0.1mm, 0.004 in) or other damage on the companion flange surface which contacts the front oil seal lips are found, replace with new one.

ADJUSTING AND SELECTING WASHERS

Side Gear Back Clearance

- Assemble the differential parts if they are disassembled. Refer to "Differential Assembly".

1. Place the differential case straight up so that the side gear to be measured is upward.

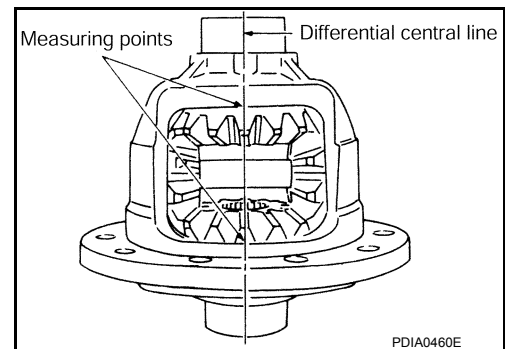

2. Using feeler gauges, measure the clearance between the side gear back and differential case at three different points, while rotating the side gear. Average the three readings to calculate the clearance. (Measure the clearance of the other side as well.)

Side gear back clearance: Refer to [DLN-247, "Inspection and Adjustment"](#)

- If the side gear back clearance is outside of the specification, use a thicker or thinner side gear thrust washer to adjust. Refer to [DLN-228, "Disassembly and Assembly"](#).

If the side gear back clearance is greater than specification:

Use a thicker side gear thrust washer.

If the side gear back clearance is less than specification:

Use a thinner side gear thrust washer.

CAUTION:

- Insert feeler gauges with the same thickness on both sides to prevent side gear from tilting.
- Each gear should rotate smoothly without excessive resistance during differential motion.
- Select a side gear thrust washer for right and left individually.

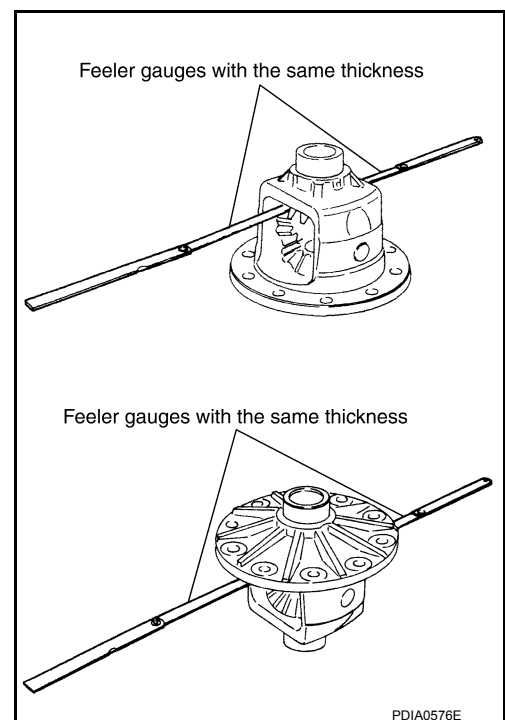

REAR FINAL DRIVE

[C200]

< UNIT DISASSEMBLY AND ASSEMBLY >

NOTE:

Side gear back clearance is clearance between side gear and differential case for adjusting side gear backlash.

Side Bearing Preload Torque

- A selection of side bearing adjusting washers is required for successful completion of this procedure.

1. Apply differential gear oil to the side bearings, and install the differential case assembly with the side bearing outer races into the gear carrier.

CAUTION:

Do not reuse side bearing outer race when replacing side bearing inner race (replace as a set).

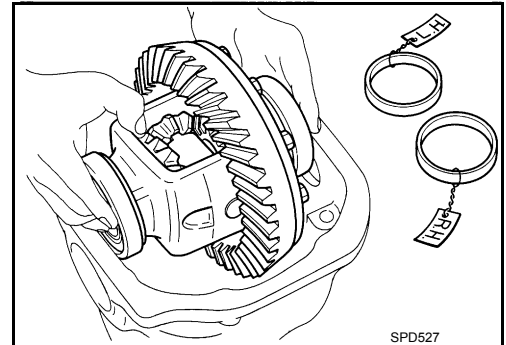

2. Insert the left and right original side bearing adjusting washers in place between side bearings and gear carrier using Tool.

Tool number : KV38100600 (J-25267)

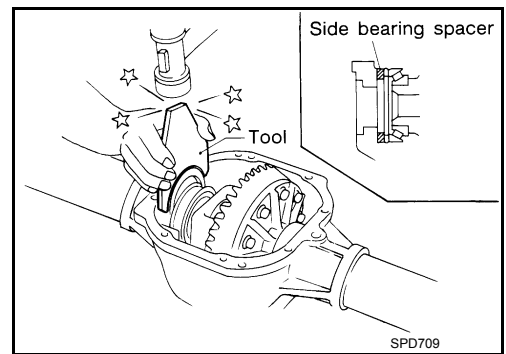

3. Align the matching mark on the side bearing cap with the matching mark on the gear carrier.
4. Install the side bearing caps and tighten the side bearing cap bolts to the specified torque. Refer to [DLN-228, "Disassembly and Assembly"](#).
5. Turn the differential assembly several times to seat the side bearings.

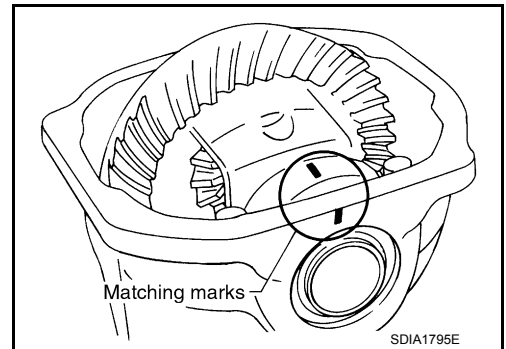

6. To determine side bearing preload torque, measure the pulling force of the differential assembly at the drive gear bolt using Tool.

Tool number : — (J-8129)

Specification Refer to [DLN-247, "Inspection and Adjustment"](#)

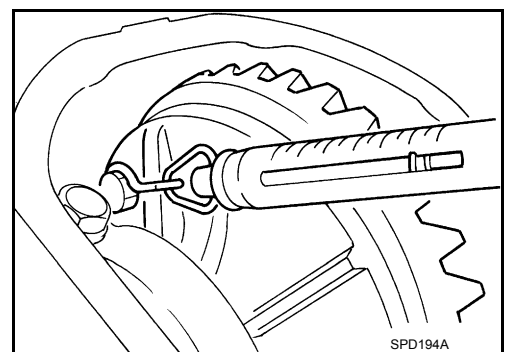

NOTE:

If pulling force of the differential assembly at the drive gear bolt is within specification, side bearing preload torque will also be within specification. Refer to [DLN-228, "Disassembly and Assembly"](#).

REAR FINAL DRIVE

< UNIT DISASSEMBLY AND ASSEMBLY >

[C200]

7. If the pulling force is outside the specification, use a thicker or thinner side bearing adjusting washer to adjust. Refer to [DLN-228](#), "Disassembly and Assembly".

If the pulling force is less than the specification:

Use a thicker side bearing adjusting washer.

If the pulling force is greater than the specification:

Use a thinner side bearing adjusting washer.

CAUTION:

Select a side bearing adjusting washer for right and left individually.

8. Record the total amount of washer thickness required for the correct side bearing preload torque.

Drive Pinion Height

1. Make sure all parts are clean and that the bearings are well lubricated.
2. Assemble the drive pinion bearings onto the Tool.

Tool number : — (J-34309)

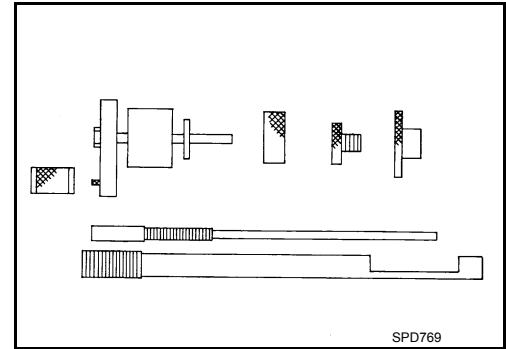
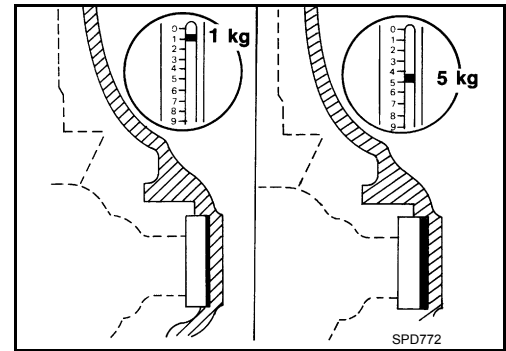

- **Drive pinion front bearing;** make sure the J-34309-3 drive pinion front bearing seat is secured tightly against the J-34309-2 gauge anvil. Then turn the J-34309-5 drive pinion front bearing pilot to secure the drive pinion bearing in its proper position.
- **Drive pinion rear bearing;** the J-34309-8 drive pinion rear bearing pilot is used to center the drive pinion rear bearing only. The J-34309-4 drive pinion rear bearing locking seat is used to lock the drive pinion rear bearing to the assembly.
- **Installation of J-34309-9 and J-34309-16;** place a suitable 2.5 mm (0.098 in) thick plain washer between J-34309-9 and J-34309-16. Both surfaces of J-34309-9 and J-34309-16 must be parallel with a clearance of 2.5 mm (0.098 in).

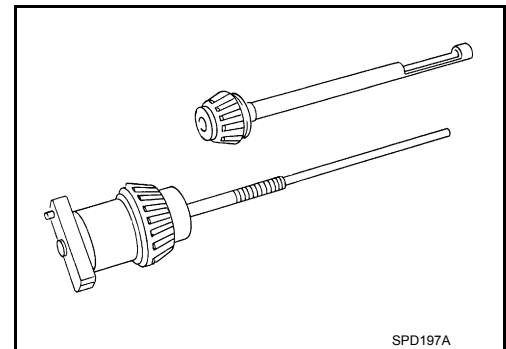

3. Install the drive pinion rear bearing inner race into the gear carrier. Then insert the drive pinion height adjusting washer selector tool, J-34309-1, gauge screw assembly.

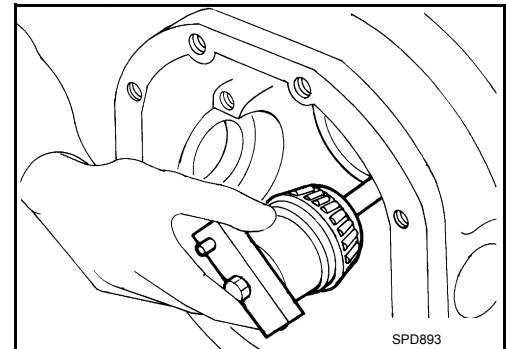

REAR FINAL DRIVE

< UNIT DISASSEMBLY AND ASSEMBLY >

[C200]

4. Assemble the drive pinion front bearing inner race and the J-34309-2 gauge anvil. Assemble them together with the J-34309-1 gauge screw in the gear carrier. Make sure that the drive pinion height gauge plate, J-34309-16, will turn a full 360°. Tighten the two sections together by hand.

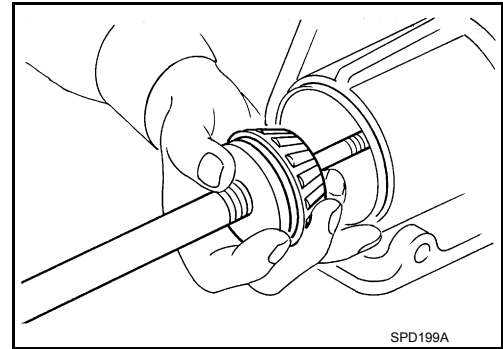

5. Turn the assembly several times to seat the drive pinion bearings.

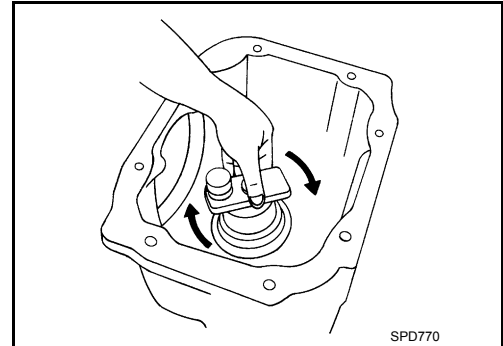

6. Measure the turning torque at the end of the J-34309-2 gauge anvil using Tool.

Tool number : ST3127S000 (J-25765- A)

Turning torque: : 1.0 - 1.3 N·m (0.11 - 0.13 kg-m, 9 - 11 in-lb)

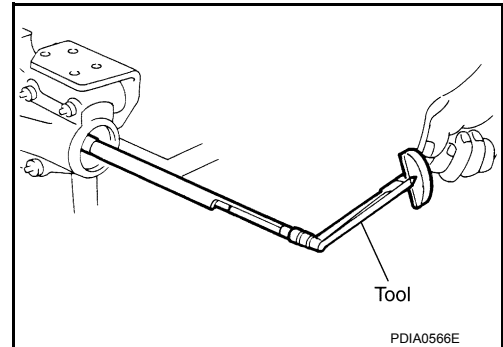

7. Place the J-34309-11 drive pinion height adapter onto the gauge plate and tighten it by hand.

CAUTION:

Make sure all machined surfaces are clean.

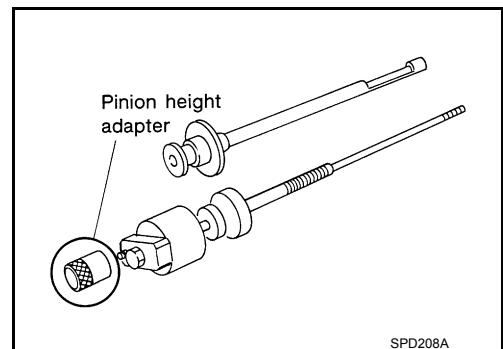

8. Position the side bearing discs, Tool, and arbor firmly into the side bearing bores. Install the side bearing caps and tighten the side bearing cap bolts to the specified torque. Refer to "[DLN-228. \"Disassembly and Assembly\"](#)".

Tool number : — (J-25269-4)

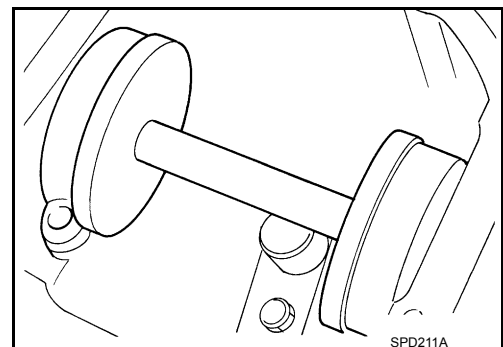

REAR FINAL DRIVE

[C200]

< UNIT DISASSEMBLY AND ASSEMBLY >

9. Select the correct standard drive pinion height adjusting washer thickness. Select by using a standard gauge of 3 mm (0.12 in) and your J-34309-101 feeler gauge. Measure the distance between the J-34309-11 drive pinion height adapter, including the standard gauge and the arbor.

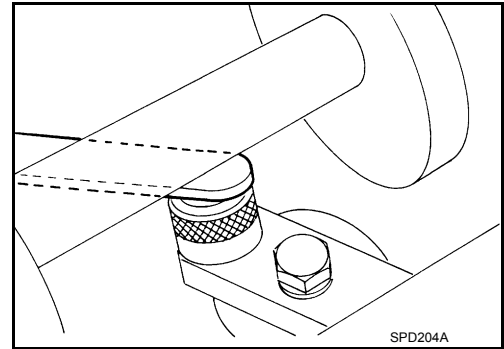

10. Write down the exact measurement (the value of feeler gauge).

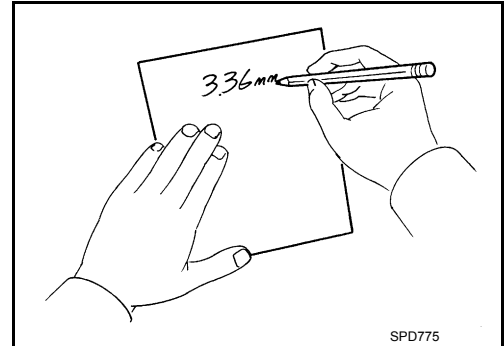

11. Correct the drive pinion height adjusting washer size by referring to the drive pinion "head number".

There are two numbers painted on the drive pinion. The first one refers to the drive pinion and drive gear as a matched set. This number should be the same as the number on the drive gear. The second number is the drive pinion "head number". It refers to the ideal drive pinion height from standard for quietest operation. Use the following chart to determine the correct drive pinion height adjusting washer.

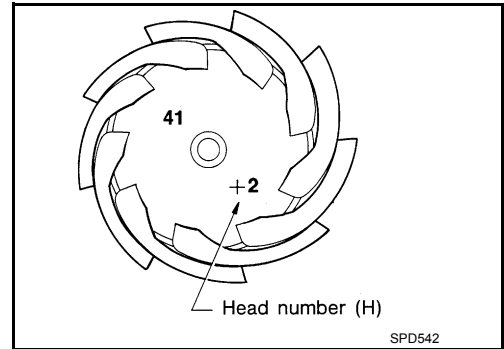

Head number	Add or remove from the standard drive pinion height adjusting washer thickness measurement
-6	Add 0.06 mm (0.0024 in)
-5	Add 0.05 mm (0.0020 in)
-4	Add 0.04 mm (0.0016 in)
-3	Add 0.03 mm (0.0012 in)
-2	Add 0.02 mm (0.0008 in)
-1	Add 0.01 mm (0.0004 in)
0	Use the selected washer thickness
+1	Subtract 0.01 mm (0.0004 in)
+2	Subtract 0.02 mm (0.0008 in)
+3	Subtract 0.03 mm (0.0012 in)
+4	Subtract 0.04 mm (0.0016 in)
+5	Subtract 0.05 mm (0.0020 in)
+6	Subtract 0.06 mm (0.0024 in)

12. Select the correct drive pinion height adjusting washer. Refer to [DLN-228, "Disassembly and Assembly"](#).

REAR FINAL DRIVE

[C200]

< UNIT DISASSEMBLY AND ASSEMBLY >

13. Remove the Tool from the gear carrier and disassemble to retrieve the drive pinion bearings.

Tool number : — (J-34309)

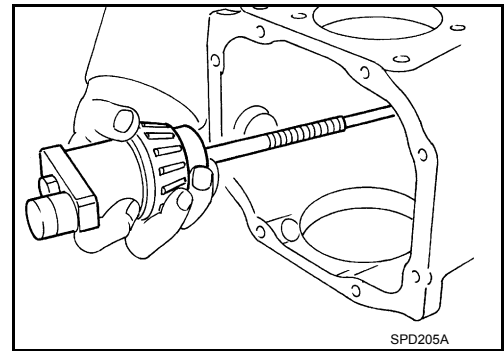

ASSEMBLY

Drive Pinion Assembly

1. Install the new drive pinion front and rear bearing outer races using Tools.

Tool number (A): ST30611000 (J-25742-1)
(B): ST30621000 (J-25742-5)
(C): ST30613000 (J-25742-3)

CAUTION:

- First tap the drive pinion bearing outer race until it becomes flush with the gear carrier.
- Do not reuse drive pinion front and rear bearing outer race.

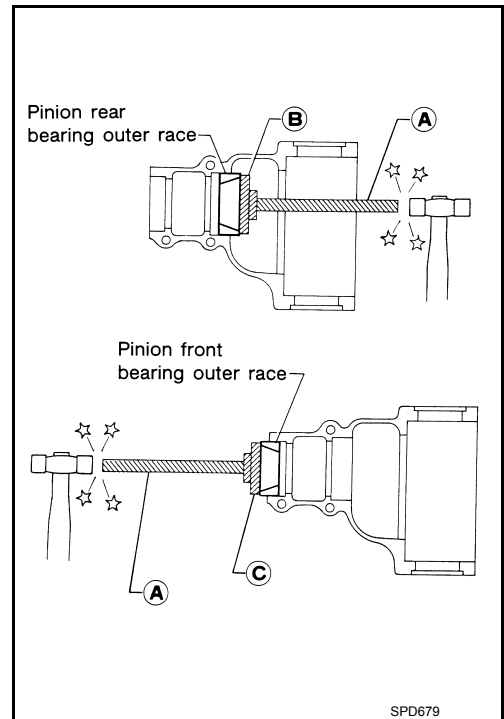

2. Select a drive pinion height adjusting washer. Refer to [DLN-228, "Disassembly and Assembly"](#).
3. Install the selected drive pinion height adjusting washer to the drive pinion. Press the new drive pinion rear bearing inner race to it using Tool.

Tool number : ST30901000 (J-26010-01)

CAUTION:

- Install the drive pinion height adjusting washer in the proper direction as shown.
- Do not reuse drive pinion rear bearing inner race.

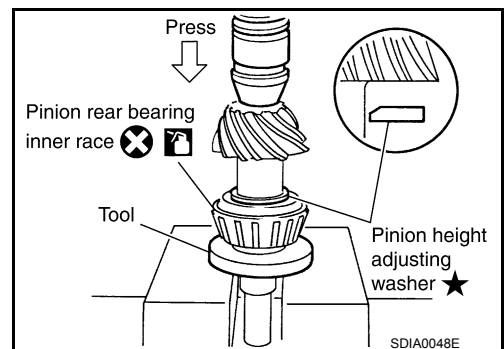

REAR FINAL DRIVE

< UNIT DISASSEMBLY AND ASSEMBLY >

[C200]

4. Assemble the new collapsible spacer to the drive pinion.

CAUTION:

Do not reuse collapsible spacer.

5. Apply differential gear oil to the drive pinion rear bearing, and install the drive pinion assembly to the gear carrier.
6. Apply differential gear oil to the drive pinion front bearing, and install the new drive pinion front bearing inner race to the drive pinion assembly.

CAUTION:

Do not reuse drive pinion front bearing inner race.

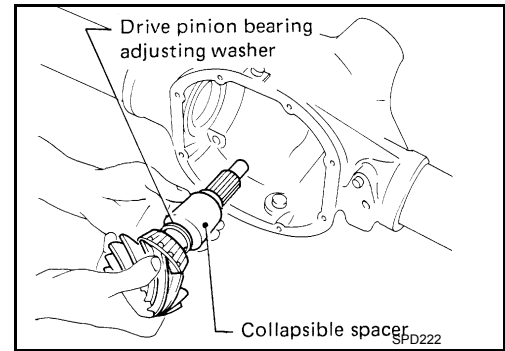

7. Press the drive pinion front bearing inner race to the drive pinion as far as drive pinion lock nut can be tightened using suitable spacer.

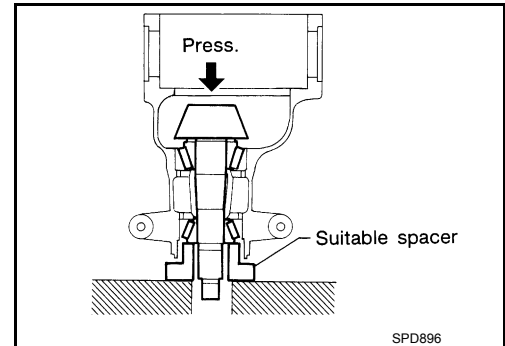

8. Apply multi-purpose grease to the lips and differential gear oil to the circumference of the new front oil seal. Then drive the new front oil seal in evenly until it becomes flush with the gear carrier using Tool.

Tool number : KV38100500 (J-25273)

CAUTION:

- Do not reuse front oil seal.
- Do not incline the new front oil seal when installing.
- Apply multi-purpose grease to the lips and differential gear oil to the circumference of the new front oil seal.

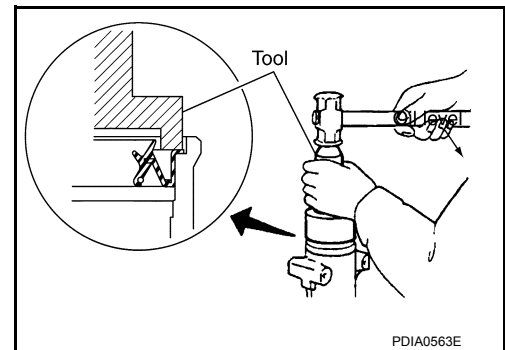

9. Install the companion flange to the drive pinion while aligning the matching marks.

REAR FINAL DRIVE

< UNIT DISASSEMBLY AND ASSEMBLY >

[C200]

10. Apply anti-corrosive oil to the threads of the drive pinion and the seating surface of the new drive pinion lock nut. Then adjust the drive pinion lock nut tightening torque using suitable tool (A), and check the drive pinion bearing preload torque using Tool (B).

Tool number (B): ST3127S000 (J-25765-A)

Drive pinion bearing preload torque:

Refer to [DLN-247, "Inspection and Adjustment"](#)

CAUTION:

- Do not reuse drive pinion lock nut.
- Apply anti-corrosive oil to the threads of the drive pinion and the seating surface of the new drive pinion lock nut.
- Adjust the drive pinion lock nut tightening torque to the lower limit first. Do not exceed the drive pinion lock nut specified torque. Refer to [DLN-228, "Disassembly and Assembly"](#).
- If the drive pinion bearing preload torque exceeds the specified value, replace collapsible spacer and tighten it again to adjust. Do not loosen drive pinion lock nut to adjust the drive pinion bearing preload torque.
- After adjustment, rotate drive pinion back and forth 2 to 3 times to check for unusual noise, rotation malfunction, and other malfunctions.

11. Check companion flange runout. Refer to [DLN-228, "Disassembly and Assembly"](#).
12. Install differential case assembly. Refer to [DLN-228, "Disassembly and Assembly"](#).

Differential Assembly

1. Install side gear thrust washers with the same thickness as the ones installed prior to disassembly, or reinstall the old ones on the side gears.

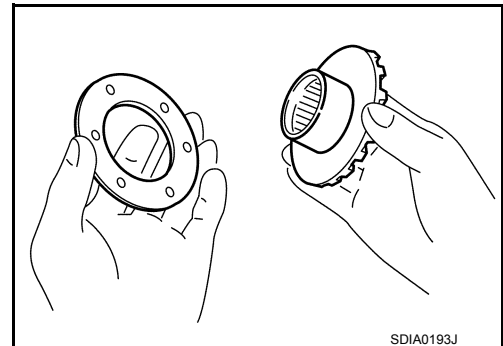

2. Install the side gears and side gear thrust washers into the differential case.

CAUTION:

Make sure that the circular clip is installed to side gears.

3. Install the pinion mate thrust washers to the two pinion mate gears. Then install the pinion mate gears with the pinion mate thrust washers by aligning them in diagonally opposite positions and rotating them into the differential case.

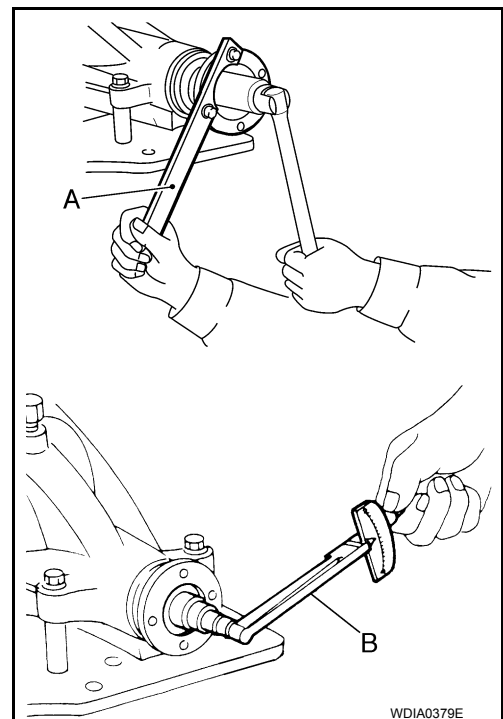
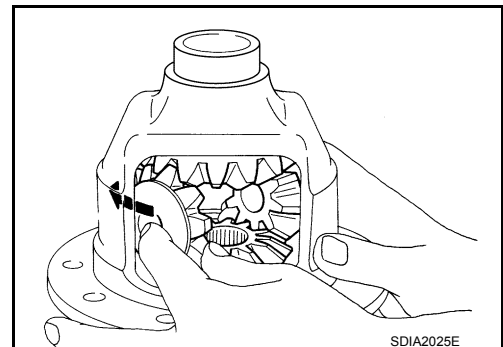

A
B
C
DLN
E
F
G
H
I
J
K
L
M
N
O
P

REAR FINAL DRIVE

[C200]

< UNIT DISASSEMBLY AND ASSEMBLY >

- Align the lock pin hole on the differential case with the lock pin hole on the pinion mate shaft, and install the pinion mate shaft.
- Measure the side gear end play. If necessary, select the appropriate side gear thrust washers. Refer to [DLN-228. "Disassembly and Assembly"](#).

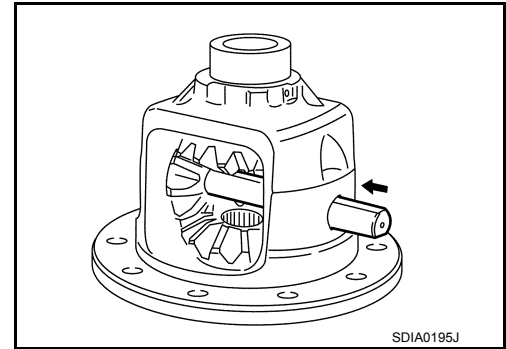

- Drive a new lock pin into the pinion mate shaft until it is flush with the differential case using suitable tool.

CAUTION:

Do not reuse lock pin.

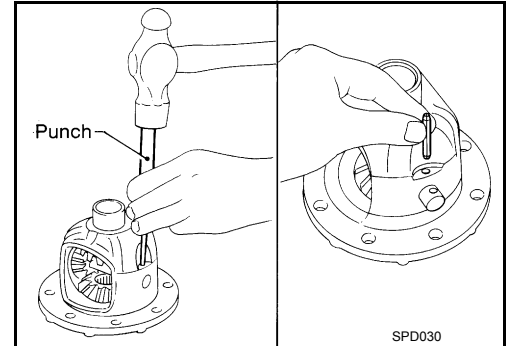

- Align the matching mark of the differential case with the mark of the drive gear, then place the drive gear onto the differential case.

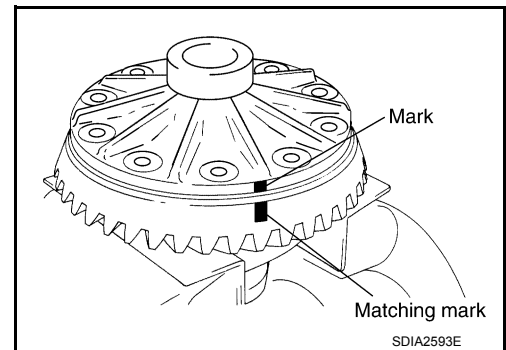

- Apply thread locking sealant into the threaded holes of the drive gear and install the bolts.
 - Use Genuine Medium Strength Thread Locking Sealant or equivalent. Refer to [GI-22. "Recommended Chemical Products and Sealants"](#).

CAUTION:

Make sure the drive gear back and threaded holes are clean.

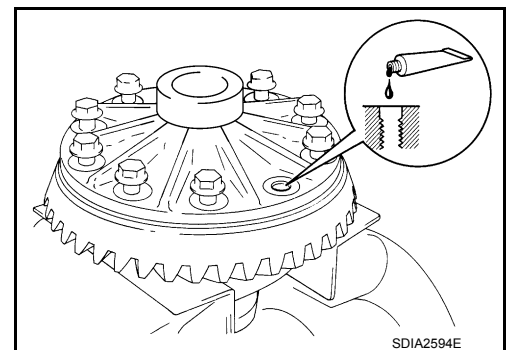

- Tighten the drive gear bolts to the specified torque. Refer to [DLN-228. "Disassembly and Assembly"](#). After tightening the drive gear bolts to the specified torque, tighten an additional 31° to 36° using Tool (A).

Tool number : KV10112100-A (BT-8653-A)

CAUTION:

- Always use Tool. Avoid tightening based on visual check alone.
- Tighten drive gear bolts in a crisscross pattern.

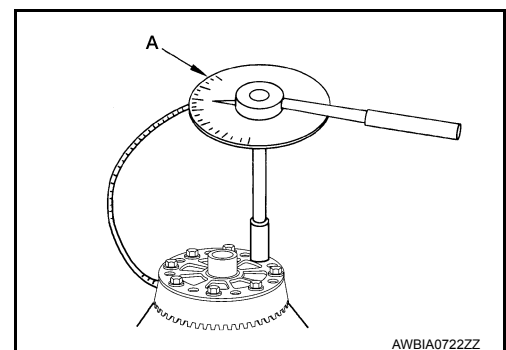

REAR FINAL DRIVE

< UNIT DISASSEMBLY AND ASSEMBLY >

[C200]

10. Press the new side bearing inner races to the differential case using Tools.

Tool number (A): ST33230000 (J-25805-01)
(B): ST33061000 (J-8107-2)

CAUTION:
Do not reuse side bearing inner race.

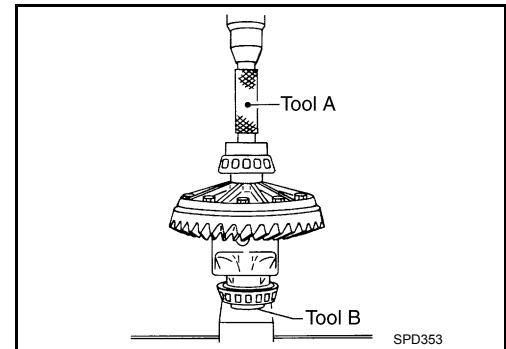

11. Install the differential case assembly with the side bearing outer races into gear carrier.
12. Measure the side bearing preload torque. If necessary, select the appropriate side bearing adjusting washers. Refer to [DLN-228, "Disassembly and Assembly"](#).

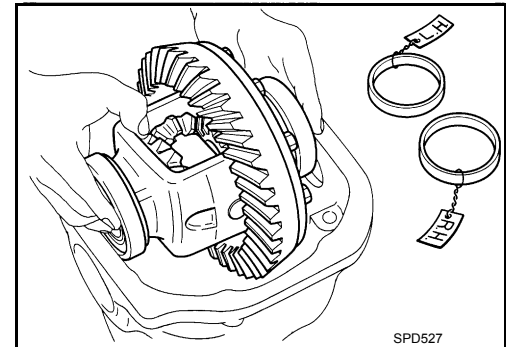

13. Insert the selected left and right side bearing adjusting washers in place between the side bearings and gear carrier using Tool.

Tool number : KV38100600 (J-25267)

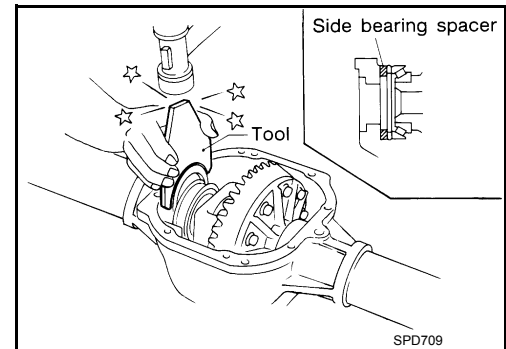

14. Install the side bearing caps with the matching marks aligned and tighten the side bearing cap bolts to the specified torque. Refer to [DLN-228, "Disassembly and Assembly"](#).

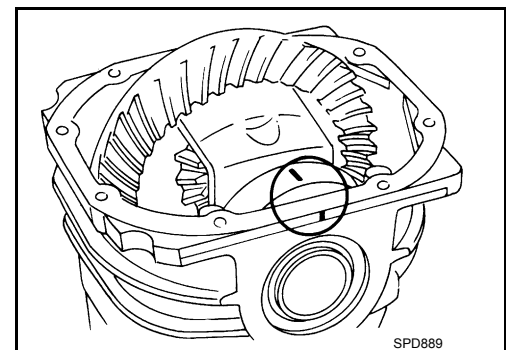

15. Check and adjust the drive gear runout, tooth contact, drive gear to drive pinion backlash, and total preload torque. Refer to ["DLN-228, "Disassembly and Assembly"](#).
Recheck above items.

REAR FINAL DRIVE

< UNIT DISASSEMBLY AND ASSEMBLY >

[C200]

16. Apply sealant to the mating surface of the carrier cover.
 - Use Genuine Silicone RTV or equivalent. Refer to [GI-22, "Recommended Chemical Products and Sealants"](#).

CAUTION:
Remove any old sealant adhering to the mating surfaces. Also remove any moisture, oil, or foreign material adhering to the application and mating surfaces.
17. Install the carrier cover to the gear carrier. Tighten the bolts to the specified torque. Refer to [DLN-228, "Disassembly and Assembly"](#).

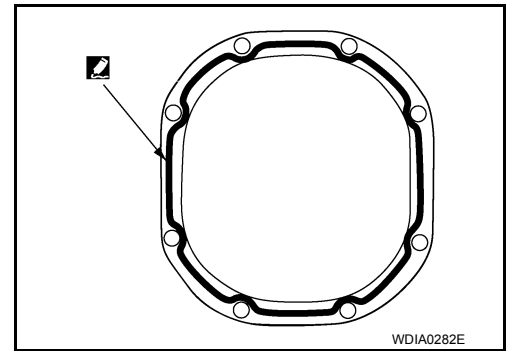

SERVICE DATA AND SPECIFICATIONS (SDS)

< SERVICE DATA AND SPECIFICATIONS (SDS)

[C200]

SERVICE DATA AND SPECIFICATIONS (SDS)

SERVICE DATA AND SPECIFICATIONS (SDS)

General Specification

INFOID:000000007324015

2WD MODELS

Applied model	QR25DE				VQ40DE				
	King cab				King cab		Crew cab		
	M/T	A/T		M/T	A/T	A/T			
	S		SV		SV	Pro 4X	SL		
Final drive model	C200								
Gear ratio	4.083	4.363*	3.692	3.916*	4.363	3.916	2.937	3.133	3.133
Number of teeth (Drive gear/Drive pinion)	49/12	48/11	48/13	47/12	48/11	47/12	47/16	47/15	47/15
Oil capacity (Approx) ℓ (US pt, Imp pt)	1.6 (3-3/8, 2-7/8)								
Number of pinion gears	2								
Drive pinion adjustment spacer type	Collapsible								

*: Option

4WD MODELS

Applied model	VQ40DE	
	King cab	Crew cab
	A/T	
	SV	S, SV, SL
Final drive model	C200	
Gear ratio	3.133	3.357
Number of teeth (Drive gear/Drive pinion)	47/15	47/14
Oil capacity (Approx.) ℓ (US pt, Imp pt)	1.6 (3-3/8, 2-7/8)	
Number of pinion gears	2	
Drive pinion adjustment spacer type	Collapsible	

Inspection and Adjustment

INFOID:000000007324016

DRIVE GEAR RUNOUT

Unit: mm (in)

Item	Runout limit
Drive gear back face	0.08 (0.0031) or less

SIDE GEAR CLEARANCE

Unit: mm (in)

Item	Specification
Side gear back clearance (Clearance between side gear and differential case for adjusting side gear backlash)	0.1 - 0.2 (0.004 - 0.008) or less (Each gear should rotate smoothly without excessive resistance during differential motion.)

PRELOAD TORQUE

SERVICE DATA AND SPECIFICATIONS (SDS)

< SERVICE DATA AND SPECIFICATIONS (SDS)

[C200]

Unit: N·m (kg-m, in-lb)

Item	Specification
Drive pinion bearing preload torque	1.1 - 1.4 (0.12 - 0.14, 10 - 12)
Side bearing preload torque (reference value determined by drive gear bolt pulling force)	0.3 - 1.5 (0.03 - 0.15, 3 - 13)
Drive gear bolt pulling force (by spring gauge)	34.2 - 39.2 N (3.5 - 4 kg, 7.7 - 8.8 lb)
Total preload torque (Total preload torque = drive pinion bearing preload torque + Side bearing preload torque)	1.4 - 2.9 (0.15 - 0.29, 13 - 25)

BACKLASH

Unit: mm (in)

Item	Specification
Drive gear to drive pinion gear	0.10 - 0.15 (0.0039 - 0.0059)

COMPANION FLANGE RUNOUT

Unit: mm (in)

Item	Runout limit
Companion flange face	0.08 (0.0031) or less
Companion flange Inner side	0.08 (0.0031) or less

SELECTIVE PARTS

Side Gear Thrust Washer

Unit: mm (in)

Thickness	Part number*	Thickness	Part number*
0.75 (0.0295)	38424 EC000	0.87 (0.0343)	38424 EC004
0.78 (0.0307)	38424 EC001	0.90 (0.0350)	38424 EC005
0.81 (0.0319)	38424 EC002	0.93 (0.0366)	38424 EC006
0.84 (0.0331)	38424 EC003		

*: Always check with the Parts Department for the latest parts information.

Drive Pinion Height Adjusting Washer

Unit: mm (in)

Thickness	Part number*	Thickness	Part number*
3.05 (0.1201)	38154 0C000	3.29 (0.1295)	38154 0C008
3.08 (0.1213)	38154 0C001	3.32 (0.1307)	38154 0C009
3.11 (0.1224)	38154 0C002	3.35 (0.1319)	38154 0C010
3.14 (0.1236)	38154 0C003	3.38 (0.1331)	38154 0C011
3.17 (0.1248)	38154 0C004	3.41 (0.1343)	38154 0C012
3.20 (0.1260)	38154 0C005	3.44 (0.1354)	38154 0C013
3.23 (0.1272)	38154 0C006	3.47 (0.1366)	38154 0C014
3.26 (0.1283)	38154 0C007	3.50 (0.1378)	38154 0C015

*: Always check with the Parts Department for the latest parts information.

Side Bearing Adjusting Washer

Unit: mm (in)

Thickness	Part number*	Thickness	Part number*
2.00 (0.0787)	38453 N3100	2.35 (0.0925)	38453 N3107
2.05 (0.0807)	38453 N3101	2.40 (0.0945)	38453 N3108
2.10 (0.0827)	38453 N3102	2.45 (0.0965)	38453 N3109
2.15 (0.0846)	38453 N3103	2.50 (0.0984)	38453 N3110
2.20 (0.0866)	38453 N3104	2.55 (0.1004)	38453 N3111
2.25 (0.0886)	38453 N3105	2.60 (0.1024)	38453 N3112
2.30 (0.0906)	38453 N3106	2.65 (0.1043)	38453 N3113

*: Always check with the Parts Department for the latest parts information.

PRECAUTION

PRECAUTIONS

Precaution for Supplemental Restraint System (SRS) "AIR BAG" and "SEAT BELT PRE-TENSIONER"

INFOID:000000007324017

The Supplemental Restraint System such as "AIR BAG" and "SEAT BELT PRE-TENSIONER", used along with a front seat belt, helps to reduce the risk or severity of injury to the driver and front passenger for certain types of collision. This system includes seat belt switch inputs and dual stage front air bag modules. The SRS system uses the seat belt switches to determine the front air bag deployment, and may only deploy one front air bag, depending on the severity of a collision and whether the front occupants are belted or unbelted. Information necessary to service the system safely is included in the SR and SB section of this Service Manual.

WARNING:

- To avoid rendering the SRS inoperative, which could increase the risk of personal injury or death in the event of a collision which would result in air bag inflation, all maintenance must be performed by an authorized NISSAN/INFINITI dealer.
- Improper maintenance, including incorrect removal and installation of the SRS, can lead to personal injury caused by unintentional activation of the system. For removal of Spiral Cable and Air Bag Module, see the SR section.
- Do not use electrical test equipment on any circuit related to the SRS unless instructed to in this Service Manual. SRS wiring harnesses can be identified by yellow and/or orange harnesses or harness connectors.

PRECAUTIONS WHEN USING POWER TOOLS (AIR OR ELECTRIC) AND HAMMERS

WARNING:

- When working near the Airbag Diagnosis Sensor Unit or other Airbag System sensors with the Ignition ON or engine running, DO NOT use air or electric power tools or strike near the sensor(s) with a hammer. Heavy vibration could activate the sensor(s) and deploy the air bag(s), possibly causing serious injury.
- When using air or electric power tools or hammers, always switch the Ignition OFF, disconnect the battery, and wait at least 3 minutes before performing any service.

Precaution for Servicing Rear Final Drive

INFOID:000000007324018

- Before starting diagnosis of the vehicle, understand the symptoms well. Perform correct and systematic operations.
- Check for the correct installation status prior to removal or disassembly. When matching marks are required, be certain they do not interfere with the function of the parts they are applied to.
- Overhaul should be done in a clean work area, a dust proof area is recommended.
- Before disassembly, completely remove sand and mud from the exterior of the unit, preventing them from entering into the unit during disassembly or assembly.
- Always use shop paper for cleaning the inside of components.
- Avoid using cotton gloves or a shop cloth to prevent the entering of lint.
- Check appearance of the disassembled parts for damage, deformation, and abnormal wear. Replace them with new ones if necessary.
- Gaskets, seals and O-rings should be replaced any time the unit is disassembled.
- Clean and flush the parts sufficiently and blow them dry.
- Be careful not to damage sliding surfaces and mating surfaces.
- When applying sealant, remove the old sealant from the mating surface; then remove any moisture, oil, and foreign materials from the application and mating surfaces.
- In principle, tighten nuts or bolts gradually in several steps working diagonally from inside to outside. If a tightening sequence is specified, observe it.
- During assembly, observe the specified tightening torque.
- Add new differential gear oil, petroleum jelly, or multi-purpose grease, as specified.

A
B
C
DLN
E
F
G
H
I
J
K
L
M
N
O
P

PREPARATION

< PREPARATION >

[REAR FINAL DRIVE: M226]

PREPARATION

PREPARATION

Special Service Tool

INFOID:000000007324019

The actual shapes of Kent-Moore tools may differ from those of special service tools illustrated here.

Tool number (Kent-Moore No.) Tool name	Description
ST33290001 (J-34286) Puller	Removing front oil seal
ST15310000 (—) Drift	Installing front oil seal a: 96 mm (3.77 in) dia. b: 84 mm (3.30 in) dia.
ST3127S000 (J-25765-A) Preload gauge set <ol style="list-style-type: none"> 1. GG91030000 (J-25765) Torque wrench 2. HT62940000 (1/2") (—) Socket adapter 3. HT62900000 (3/8") (—) Socket adapter 	Inspecting drive pinion bearing preload and total preload
— (C-4164) Adjuster tool	Removing and installing side bearing ad- juster

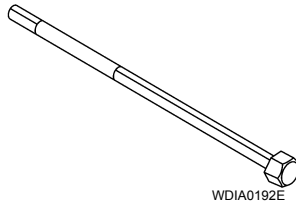
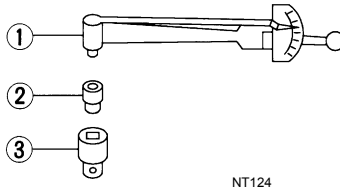
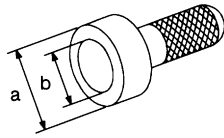
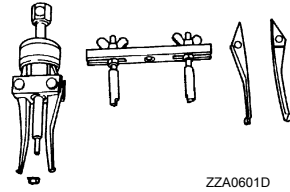

PREPARATION

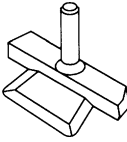
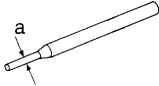

< PREPARATION >

[REAR FINAL DRIVE: M226]

Tool number (Kent-Moore No.) Tool name	Description	
KV10111100 (J-37228) Seal cutter	Removing carrier cover	A B C
 S-NT046		
ST23550000 (—)	Removing and installing lock pin a: 4.5 mm (0.177 in) dia.	DLN E F
 NT410		

Commercial Service Tool

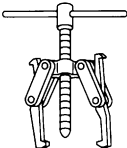
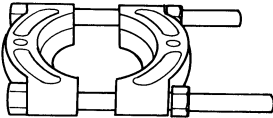
INFOID:0000000007324020

Tool name	Description	
Puller	Removing companion flange and side bearing inner race	G H I J
 NT077		
Puller	Removing side bearing inner race	K L
 ZZB0823D		
Power tool	Loosening nuts, screws and bolts	M N O P
 PIIB1407E		

DESCRIPTION

< SYSTEM DESCRIPTION >

[REAR FINAL DRIVE: M226]

SYSTEM DESCRIPTION

DESCRIPTION

Cross-Sectional View

INFOID:000000007324021

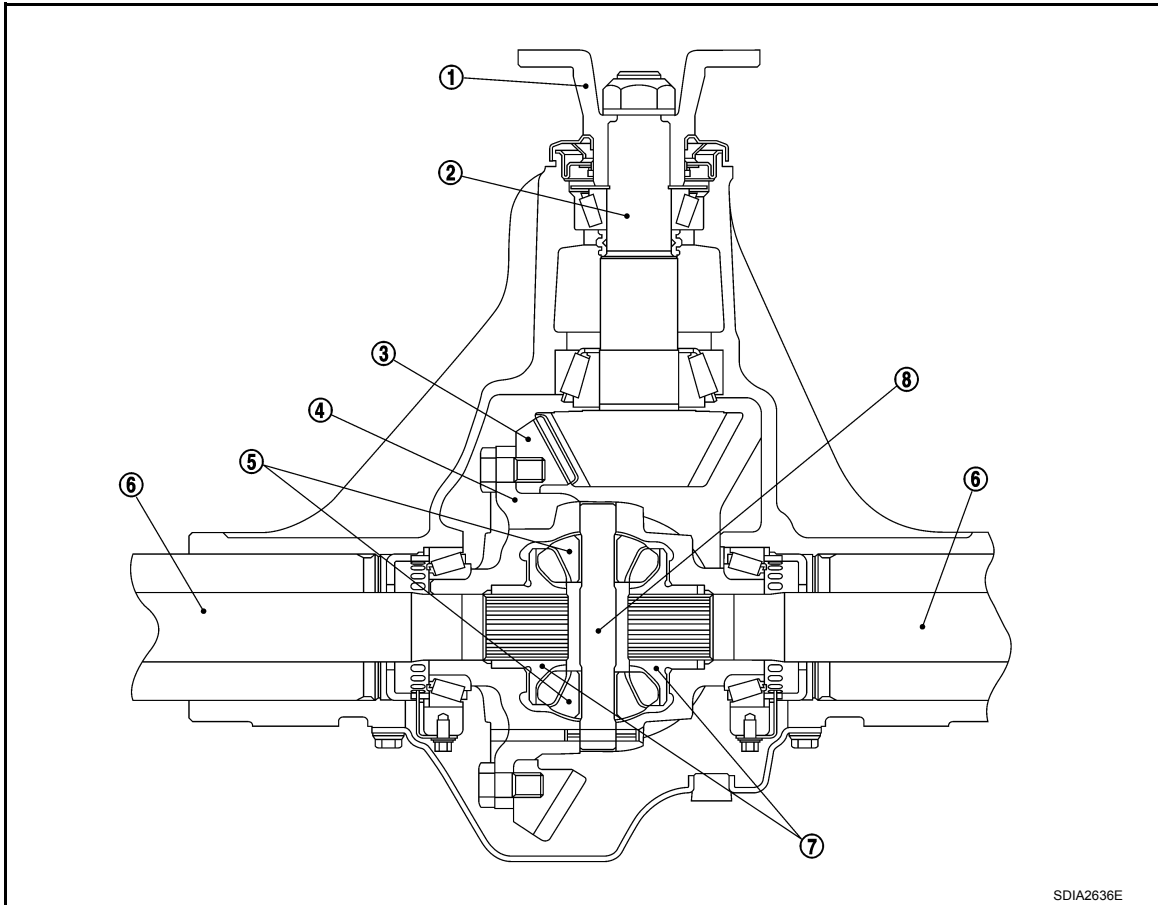

SDIA2636E

- | | | |
|----------------------|----------------------|---------------|
| 1. Companion flange | 2. Drive pinion | 3. Drive gear |
| 4. Differential case | 5. Pinion mate gear | 6. Axle shaft |
| 7. Side gear | 8. Pinion mate shaft | |

NOISE, VIBRATION AND HARSHNESS (NVH) TROUBLESHOOTING

< SYMPTOM DIAGNOSIS >

[REAR FINAL DRIVE: M226]

SYMPTOM DIAGNOSIS

NOISE, VIBRATION AND HARSHNESS (NVH) TROUBLESHOOTING

NVH Troubleshooting Chart

INFOID:000000007324022

Use the chart below to help you find the cause of the symptom. If necessary, repair or replace these parts.

Reference page	Possible cause and SUSPECTED PARTS	Symptom	Noise
—	Gear tooth rough	x	
DLN-253	Gear contact improper	x	
—	Tooth surfaces worn	x	
DLN-259	Backlash incorrect	x	
DLN-259	Companion flange excessive runout	x	
MA-18 MA-20	Gear oil improper	x	
DLN-144 , " NVH Troubleshooting Chart " (2S1330), DLN-164 , " NVH Troubleshooting Chart " (3S1330) or DLN-175 , " NVH Troubleshooting Chart " (3S1330-2BJ100)	PROPELLER SHAFT	x	
RAX-17 , " NVH Troubleshooting Chart ", RSU-4 , " NVH Troubleshooting Chart "	AXLE AND SUSPENSION	x	
WT-43 , " NVH Troubleshooting Chart "	TIRES	x	
RAX-17 , " NVH Troubleshooting Chart "	ROAD WHEEL	x	
BR-5 , " NVH Troubleshooting Chart "	AXLE SHAFT	x	
ST-5 , " NVH Troubleshooting Chart "	BRAKES	x	
	STEERING	x	

x: Applicable

A
B
C
DLN
E
F
G
H
I
J
K
L
M
N
O
P

PERIODIC MAINTENANCE

DIFFERENTIAL GEAR OIL

Changing Differential Gear Oil

INFOID:000000007324023

DRAINING

1. Stop engine.
2. Remove the drain plug from the rear final drive assembly to drain the differential gear oil.
3. Install the drain plug with sealant applied on the threads to the rear final drive assembly. Tighten to the specified torque. Refer to [DLN-259, "Disassembly and Assembly"](#).
 - Use High Performance Thread Sealant or equivalent. Refer to [GI-22, "Recommended Chemical Products and Sealants"](#).

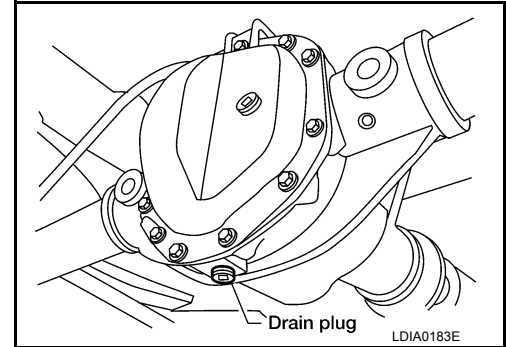

FILLING

1. Remove the filler plug from the rear final drive assembly.
2. Fill the rear final drive assembly with new differential gear oil until the level reaches the specified level near the filler plug hole.

Differential gear oil grade and capacity : Refer to [MA-18, "FOR USA AND CANADA : Fluids and Lubricants"](#).

3. Install the filler plug with sealant applied on the threads to the rear final drive assembly. Tighten to the specified torque. Refer to [DLN-259, "Disassembly and Assembly"](#).
 - Use High Performance Thread Sealant or equivalent. Refer to [GI-22, "Recommended Chemical Products and Sealants"](#).

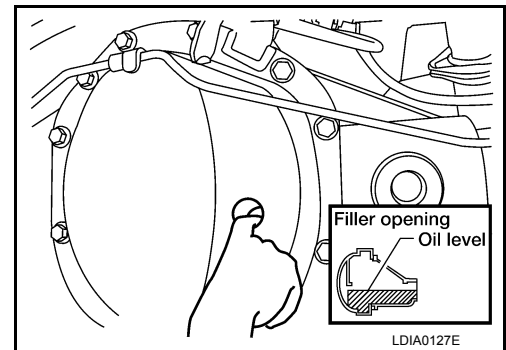

Checking Differential Gear Oil

INFOID:000000007324024

DIFFERENTIAL GEAR OIL LEAKAGE AND LEVEL

1. Make sure that differential gear oil is not leaking from the rear final drive assembly or around it.
2. Check the differential gear oil level from the filler plug hole as shown.

CAUTION:

Do not start engine while checking differential gear oil level.

3. Install the filler plug with sealant applied on the threads to the rear final drive assembly. Tighten to the specified torque. Refer to [DLN-259, "Disassembly and Assembly"](#).
 - Use High Performance Thread Sealant or equivalent. Refer to [GI-22, "Recommended Chemical Products and Sealants"](#).

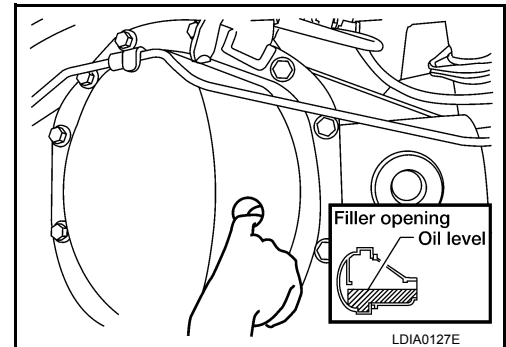

REMOVAL AND INSTALLATION

FRONT OIL SEAL

Removal and Installation

INFOID:000000007324025

REMOVAL

1. Remove rear propeller shaft. Refer to [DLN-146. "Removal and Installation"](#) (2S1330), [DLN-166. "Removal and Installation"](#) (3S1330) or [DLN-177. "Removal and Installation"](#) (3S1330-2BJ100).
2. Remove brake calipers and rotors. Refer to [BR-40. "Removal and Installation of Brake Caliper and Disc Rotor"](#).
3. Measure the total preload torque. Refer to [DLN-268. "Inspection and Adjustment"](#).

NOTE:

Record the total preload torque measurement.

4. Remove the drive pinion lock nut using suitable tool.

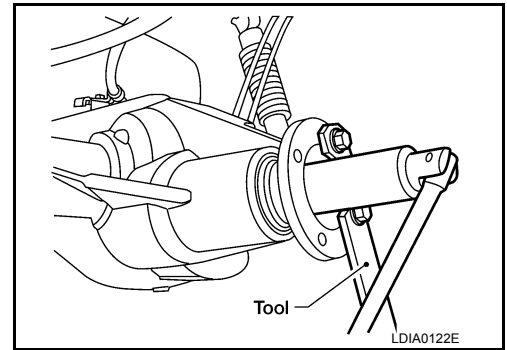

5. Put matching marks on the companion flange and drive pinion using paint.

CAUTION:

Use paint to make the matching marks. Do not damage the companion flange or drive pinion.

6. Remove the companion flange using suitable tool.

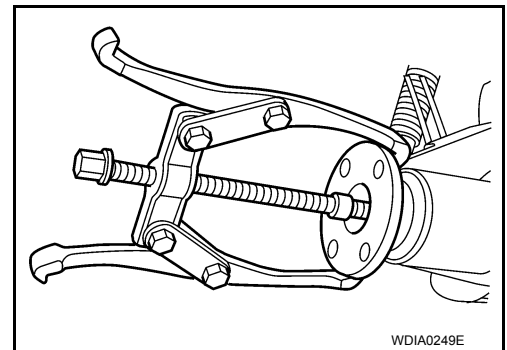

7. Remove oil seal/dust shield and discard.

CAUTION:

Do not reuse oil seal/dust shield

8. Remove the front oil seal using Tool.

Tool number : ST33290001 (J-34286)

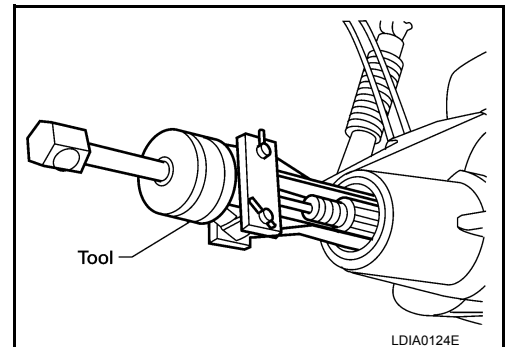

INSTALLATION

A
B
C
DLN
E
F
G
H
I
J
K
L
M
N
O
P

FRONT OIL SEAL

< REMOVAL AND INSTALLATION >

[REAR FINAL DRIVE: M226]

1. Apply multi-purpose grease to the lips of the new front oil seal. Then drive the new front oil seal in evenly until it becomes flush with the gear carrier using Tool.

Tool number : ST15310000 (—)

CAUTION:

- Do not reuse front oil seal.
- Do not incline the new front oil seal when installing.
- Apply multi-purpose grease to the lips and differential gear oil to the circumference of the new front oil seal.

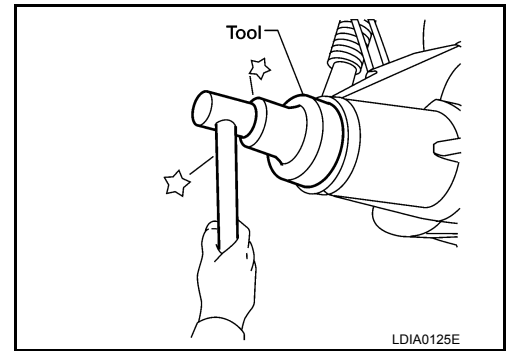

2. Install oil seal/dust shield.

CAUTION:

Do not reuse oil seal/dust shield.

3. Install the companion flange to the drive pinion while aligning the matching marks.
4. Apply anti-corrosive oil to the threads of the drive pinion and the seating surface of the new drive pinion lock nut and new drive pinion lock nut washer. Then adjust the drive pinion lock nut tightening torque using suitable tool (A), and check the total preload torque using Tool (B).

Tool number (B): ST3127S000 (J-25765-A)

Total preload torque: Refer to [DLN-268, "Inspection and Adjustment"](#).

- The total preload torque should be within the total preload torque specification. When not replacing the collapsible spacer, it should also be equal to the measurement taken during removal plus an additional 0.56 N·m (0.06 Kg-m, 5 in-lb).
- If the total preload torque is low, tighten the drive pinion lock nut in 6.8 N·m (0.69 Kg-m, 5ft-lb) increments until the total preload torque is met.

CAUTION:

- Do not reuse drive pinion lock nut or drive pinion lock nut washer.
- Apply anti-corrosive oil to the threads of the drive pinion and the seating surface of the new drive pinion lock nut.
- Adjust the drive pinion lock nut tightening torque to the lower limit first. Do not exceed the drive pinion lock nut specified torque. Refer to [DLN-259, "Disassembly and Assembly"](#).
- Do not loosen drive pinion lock nut to adjust the total preload torque. If the total preload torque exceeds the specifications, replace the collapsible spacer and tighten it again to adjust. Refer to [DLN-259, "Disassembly and Assembly"](#).
- After adjustment, rotate drive pinion back and forth 2 to 3 times to check for unusual noise, rotation malfunction, and other malfunctions.

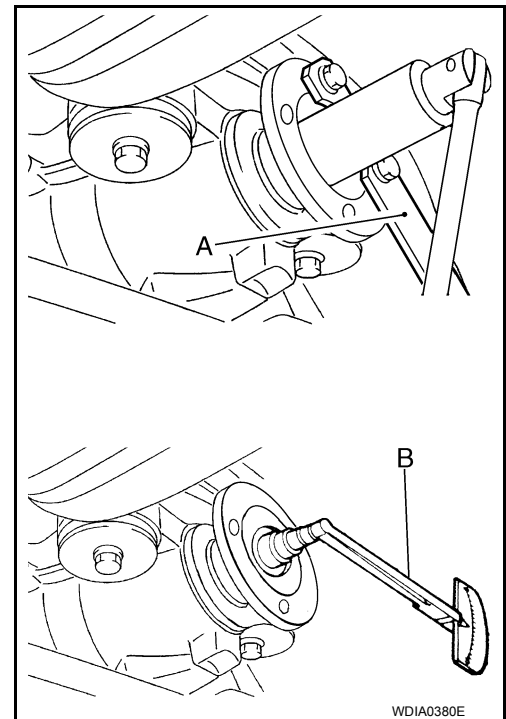

5. Installation of the remaining components is in the reverse order of removal.

CAUTION:

Check the differential gear oil level and refill as necessary. Refer to [DLN-254, "Checking Differential Gear Oil"](#).

CARRIER COVER

< REMOVAL AND INSTALLATION >

[REAR FINAL DRIVE: M226]

CARRIER COVER

Removal and Installation

INFOID:000000007324026

REMOVAL

1. Drain the differential gear oil. Refer to [DLN-254, "Changing Differential Gear Oil"](#).
2. Disconnect the parking brake cable and brake tube from the carrier cover.
3. Remove the carrier cover bolts and separate the carrier cover from the gear carrier using Tool.

Tool number : KV10111100 (J-37228)

CAUTION:

- Do not damage the mating surface.
- Do not insert flat-bladed screwdriver, this will damage the mating surface.

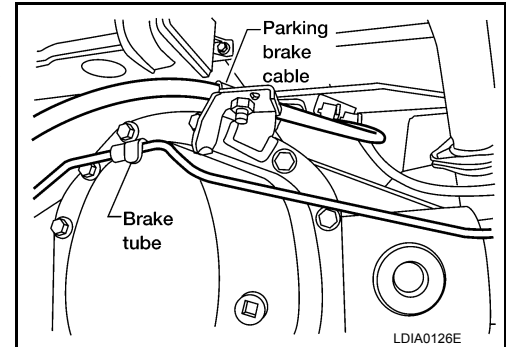

INSTALLATION

1. Apply a bead of sealant to the mating surface of the carrier cover as shown.
 - Use Genuine Silicone RTV or equivalent. Refer to [GI-22, "Recommended Chemical Products and Sealants"](#).
2. Install the carrier cover to the gear carrier. Tighten the bolts to the specified torque. Refer to [DLN-259, "Disassembly and Assembly"](#).
3. Connect the parking brake cable and brake tube to the carrier cover.
4. Fill the rear final drive assembly with recommended differential gear oil. Refer to [DLN-254, "Checking Differential Gear Oil"](#).

CAUTION:

Remove any old sealant adhering to the mating surfaces. Also remove any moisture, oil, or foreign material adhering to the application and mating surfaces.

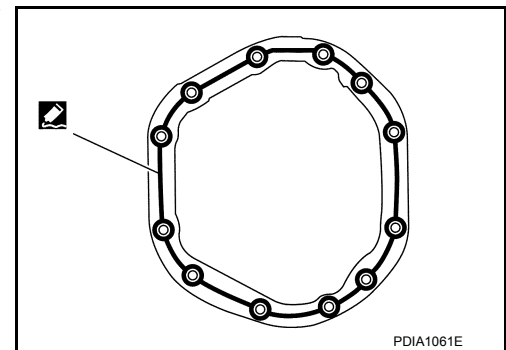

REAR FINAL DRIVE ASSEMBLY

< UNIT REMOVAL AND INSTALLATION >

[REAR FINAL DRIVE: M226]

UNIT REMOVAL AND INSTALLATION

REAR FINAL DRIVE ASSEMBLY

Removal and Installation

INFOID:000000007324027

REMOVAL

CAUTION:

- Do not damage spline, companion flange and front oil seal when removing propeller shaft.
- Before removing final drive assembly or rear axle assembly, disconnect ABS sensor harness connector from the assembly and move it away from final drive/rear axle assembly area. Failure to do so may result in sensor wires being damaged and sensor becoming inoperative.

1. Remove the rear disc brake rotors. Refer to [BR-40, "Removal and Installation of Brake Caliper and Disc Rotor"](#).
2. Remove the rear propeller shaft. Refer to [DLN-146, "Removal and Installation"](#) (2S1330), [DLN-166, "Removal and Installation"](#) (3S1330) or [DLN-177, "Removal and Installation"](#) (3S1330-2BJ100).
3. Disconnect the following components from the rear final drive assembly.
 - Wheel sensor wire harness. Refer to [BRC-114, "Removal and Installation"](#) (Type 1) or [BRC-237, "Removal and Installation"](#) (Type 2).
 - Parking brake cable
 - Brake hoses and tubes

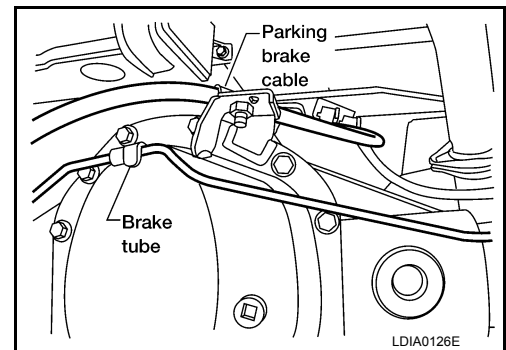

4. Support rear final drive assembly using a suitable jack.
5. Remove rear shock absorber lower bolts. Refer to [RSU-8, "Removal and Installation"](#).
6. Remove leaf spring U-bolt nuts. Refer to [RSU-9, "Removal and Installation"](#).
7. Remove rear final drive assembly.

CAUTION:

Secure rear final drive assembly to the jack while removing it.

INSTALLATION

Installation is in the reverse order of removal.

CAUTION:

Check the rear final drive assembly differential gear oil and refill as necessary. Check for fluid leaks. Refer to [DLN-254, "Checking Differential Gear Oil"](#).

REAR FINAL DRIVE ASSEMBLY

< UNIT DISASSEMBLY AND ASSEMBLY >

[REAR FINAL DRIVE: M226]

UNIT DISASSEMBLY AND ASSEMBLY

REAR FINAL DRIVE ASSEMBLY

Disassembly and Assembly

INFOID:000000007324028

COMPONENTS

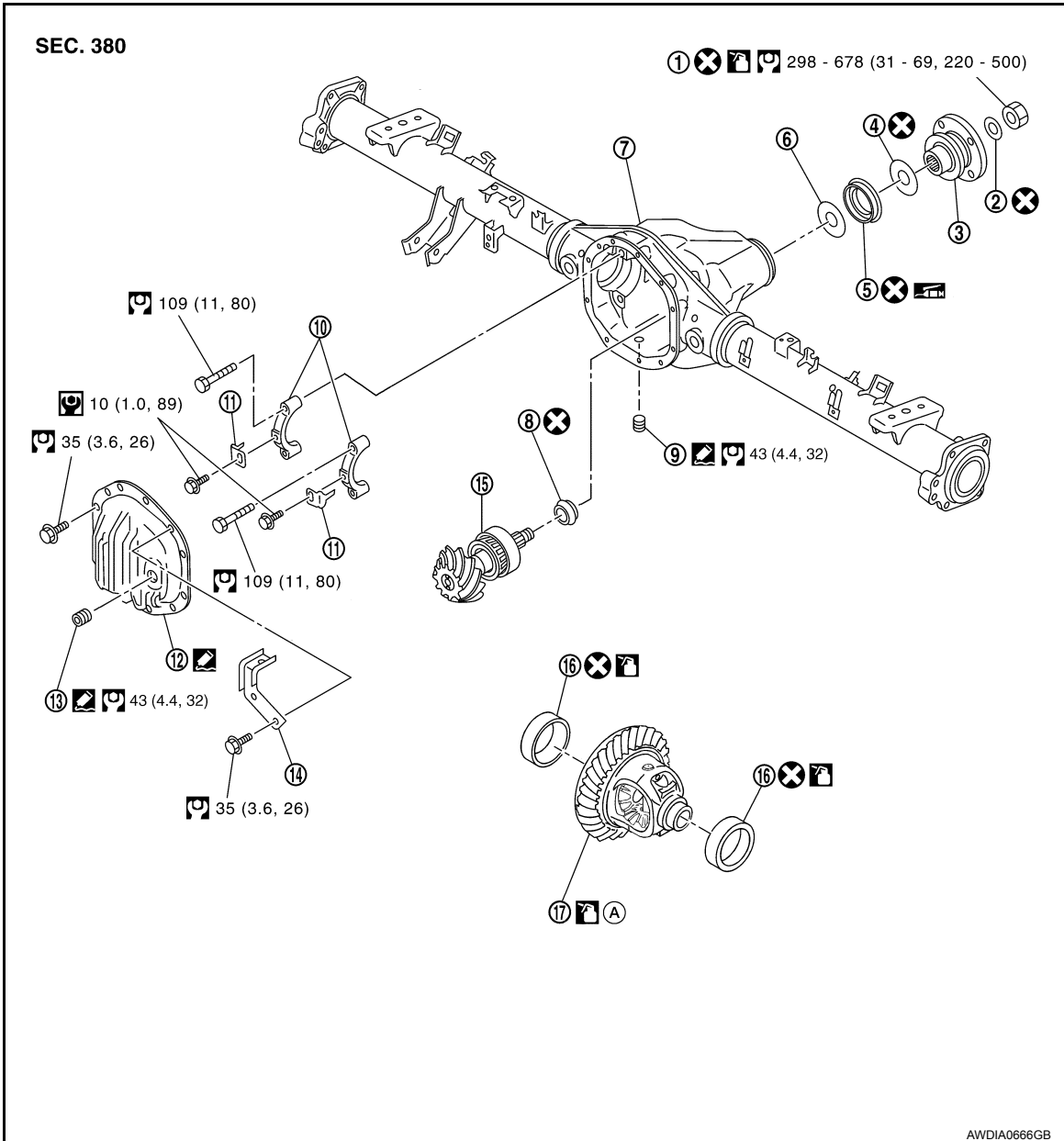

- | | | |
|--|--|---|
| 1. Drive pinion lock nut | 2. Drive pinion lock nut washer | 3. Companion flange |
| 4. Oil seal/dust shield | 5. Front oil seal | 6. Drive pinion front bearing thrust washer (non-serviceable) |
| 7. Gear carrier (non-serviceable) | 8. Collapsible spacer | 9. Drain plug (non-serviceable) |
| 10. Side bearing cap (non-serviceable) | 11. Adjuster lock plate (non-serviceable) | 12. Carrier cover |
| 13. Filler plug | 14. Bracket | 15. Drive pinion assembly (non-serviceable) |
| 16. Side bearing outer race | 17. Differential case assembly (non-serviceable) | A. Gear oil |

ASSEMBLY INSPECTION AND ADJUSTMENT

A
B
C
DLN
E
F
G
H
I
J
K
L
M
N
O
P

REAR FINAL DRIVE ASSEMBLY

< UNIT DISASSEMBLY AND ASSEMBLY >

[REAR FINAL DRIVE: M226]

- Drain the differential gear oil before inspection and adjustment. Refer to [DLN-254. "Changing Differential Gear Oil"](#).
- Remove and install the carrier cover as necessary for inspection and adjustment. Refer to [DLN-257. "Removal and Installation"](#).

Total Preload Torque

1. Rotate the drive pinion back and forth 2 to 3 times to check for unusual noise and rotation malfunction.
2. Rotate the drive pinion at least 20 times to check for smooth operation of the bearings.
3. Measure total preload torque using Tool. Refer to [DLN-268. "Inspection and Adjustment"](#).
 - If the measured value is out of the specification, check and adjust each part. Adjust the drive pinion bearing preload torque first, then adjust the side bearing preload torque.

Tool number : ST3127S000 (J-25765-A)

NOTE:

Total preload torque = Drive pinion bearing preload torque + Side bearing preload torque

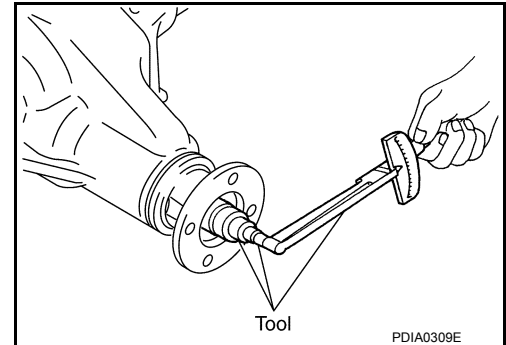

If the total preload torque is greater than specification

- On drive pinion bearings : Replace collapsible spacer.**
- On side bearings : Loosen side bearing adjuster.**

If the total preload torque is less than specification

- On drive pinion bearings : Tighten drive pinion lock nut.**
- On side bearings : Tighten side bearing adjuster.**

Tooth Contact

Checking gear tooth contact pattern is necessary to verify correct relationship between drive gear and drive pinion. Gears which are not positioned in proper arrangement may be noisy and/or have a short life. Check gear tooth contact pattern to obtain the best contact for low noise and long life.

1. Thoroughly clean drive gear and drive pinion teeth.
2. Apply red lead to the drive gear.
 - Apply red lead to both faces of three to four gears, at four locations evenly spaced on the drive gear.

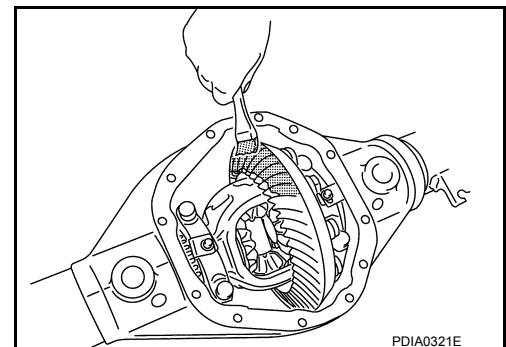

3. Hold companion flange steady by hand and rotate drive gear in both directions.

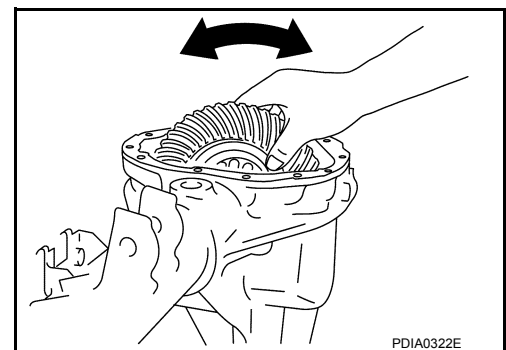

REAR FINAL DRIVE ASSEMBLY

< UNIT DISASSEMBLY AND ASSEMBLY >

[REAR FINAL DRIVE: M226]

Usually the pattern will be correct if washers are correctly calculated and the backlash is correct. However, in rare cases, trial and error processes may be employed to obtain a correct pattern. The tooth pattern is the best indication of how well a differential has been set up.

Heel contact

Face contact

Toe contact

Flank contact

To correct, increase thickness of drive pinion height adjusting washer in order to bring drive pinion close to drive gear.

To correct, reduce thickness of drive pinion height adjusting washer in order to make drive pinion go away from drive gear.

Correct tooth contact

When adjustment is completed, be sure to wipe off completely the red lead and oil or their equivalent.

SDIA2591E

4. If outside the standard, replace the final drive assembly. Refer to [DLN-258. "Removal and Installation"](#).

Backlash

1. Fit a dial indicator to the drive gear face to measure the backlash.

Backlash : Refer to [DLN-268. "Inspection and Adjustment"](#)

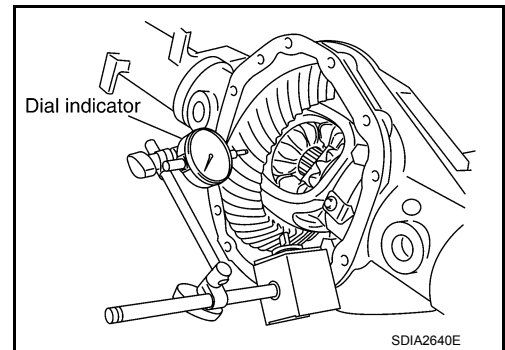

2. If the backlash is outside of the specification, adjust each side bearing adjuster.

- a. Remove adjuster lock plates.
- b. Loosen side bearing cap bolts.

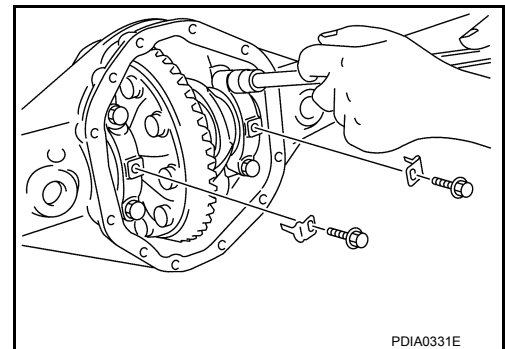

c. Tighten or loosen each side bearing adjuster using Tool.

Tool number : — (C - 4164)

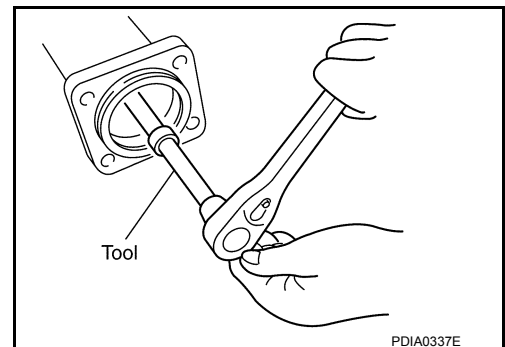

A
B
C
DLN
E
F
G
H
I
J
K
L
M
N
O
P

REAR FINAL DRIVE ASSEMBLY

< UNIT DISASSEMBLY AND ASSEMBLY >

[REAR FINAL DRIVE: M226]

If the backlash is greater than specification:

Loosen side bearing adjuster (A) and tighten side bearing adjuster (B) by the same amount.

If the backlash is less than specification:

Loosen side bearing adjuster (B) and tighten side bearing adjuster (A) by the same amount.

CAUTION:

Do not change the side bearing side bearing adjusters by different amounts as it will change the side bearing preload torque.

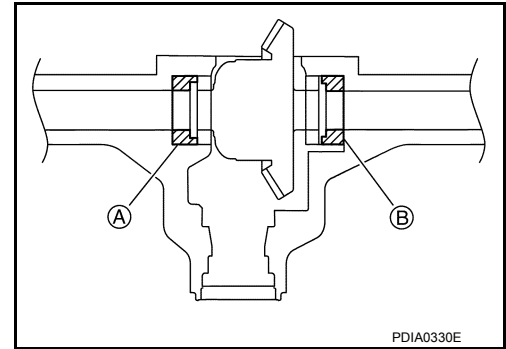

- d. Tighten side bearing cap bolts to the specified torque.
- e. Install adjuster lock plate and tighten to the specified torque.

CAUTION:

Check tooth contact and total preload torque after adjusting side bearing adjuster. Refer to [DLN-268, "Inspection and Adjustment"](#).

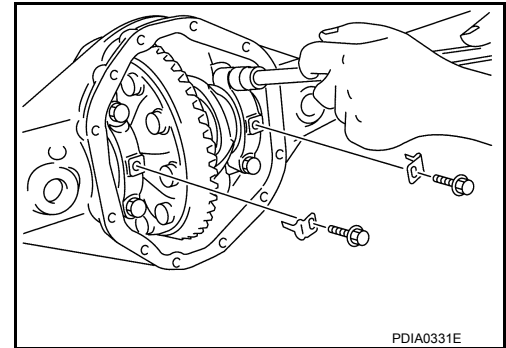

Companion Flange Runout

- 1. Rotate companion flange and check for runout on the companion flange face (inner side of the bolt holes) and companion flange inner side (socket diameter) using suitable tool. Refer to [DLN-268, "Inspection and Adjustment"](#).
- 2. If the runout is outside the runout limit, follow the procedure below to adjust.
 - a. Rotate the companion flange on the drive pinion by 90°, 180° and 270° while checking for the position where the runout is minimum.
 - b. If the runout is still outside of the runout limit after the companion flange has been rotated on the drive pinion, possible cause could be an assembly malfunction of drive pinion and drive pinion bearing or a malfunctioning drive pinion bearing.
 - c. If the runout is still outside of the runout limit after replacing the companion flange. Replace the rear final drive assembly. Refer to [DLN-258, "Removal and Installation"](#).

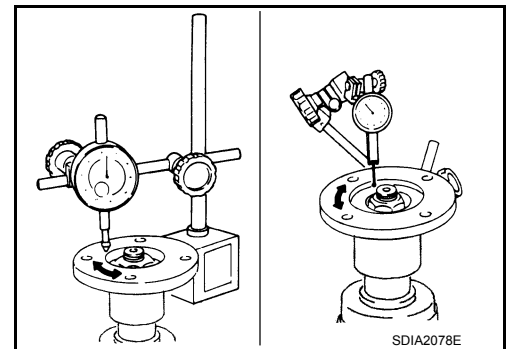

DISASSEMBLY

Differential Assembly

- 1. Remove carrier cover bolts.
- 2. Remove carrier cover using Tool.

Tool number : KV1011100 (J-37228)

CAUTION:

- Do not damage the mating surface.
- Do not insert flat-bladed screwdriver, this will damage the mating surface.

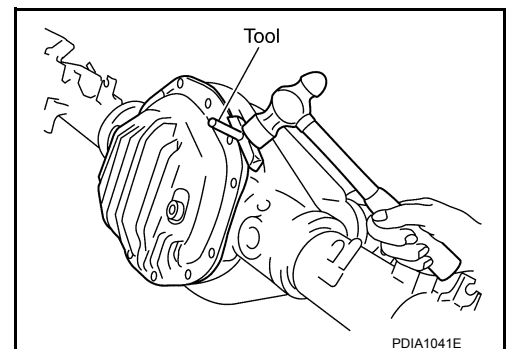

REAR FINAL DRIVE ASSEMBLY

< UNIT DISASSEMBLY AND ASSEMBLY >

[REAR FINAL DRIVE: M226]

3. For proper reinstallation, paint matching mark on one side of side bearing cap.

CAUTION:

- Side bearing caps are line-board for initial assembly. The matching marks are used to reinstall them in their original positions.
- For matching mark, use paint. Do not damage side bearing cap.

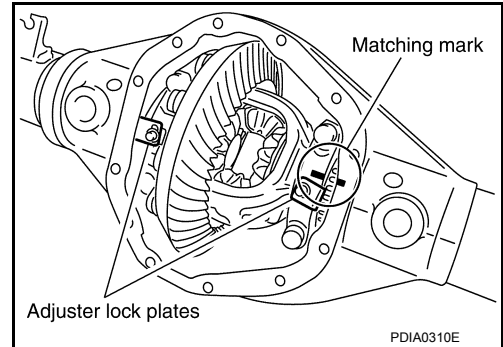

4. Remove adjuster lock plates.
5. Remove side bearing caps.

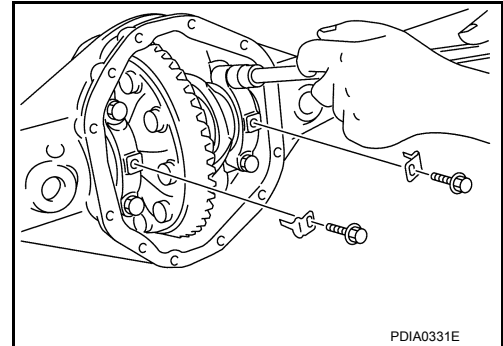

6. Loosen side bearing adjusters using Tool.

Tool number : — (C - 4164)

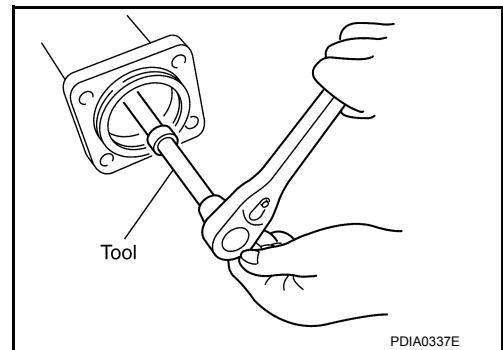

7. Remove the differential case assembly. Label side bearing outer races to keep them together with inner races. Do not mix them up.

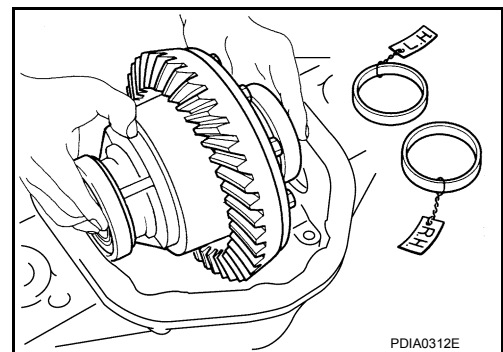

Drive Pinion Assembly

1. Put matching marks on the companion flange at location (A) and drive pinion using paint as shown.

CAUTION:

Use paint to make the matching marks. Do not damage the companion flange or drive pinion.

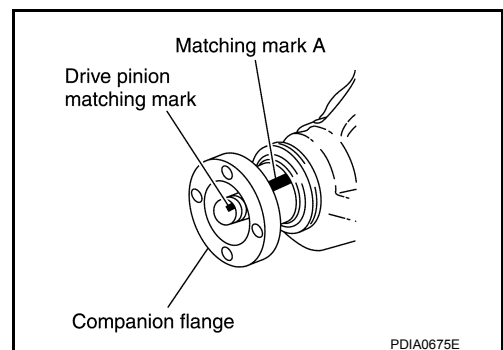

A
B
C
DLN
E
F
G
H
I
J
K
L
M
N
O
P

REAR FINAL DRIVE ASSEMBLY

< UNIT DISASSEMBLY AND ASSEMBLY >

[REAR FINAL DRIVE: M226]

2. Remove drive pinion lock nut and washer using suitable tool.

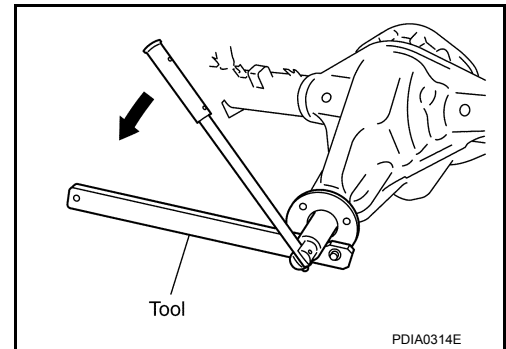

3. Remove companion flange using a suitable tool.

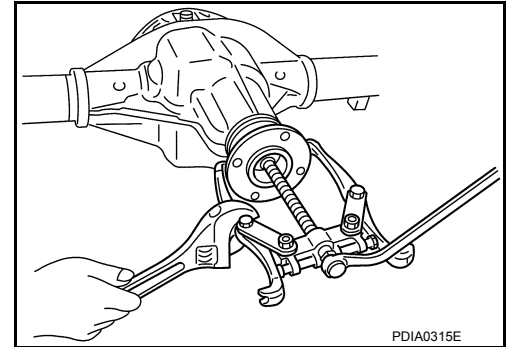

4. Remove oil seal/dust shield and discard.

CAUTION:

Do not reuse the differential oil seal.

5. Remove front oil seal using Tool.

Tool number : ST33290001 (J-34286)

CAUTION:

Do not damage gear carrier.

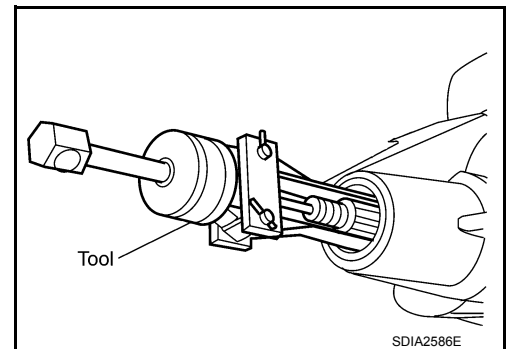

6. Remove drive pinion front bearing thrust washer.

7. Remove drive pinion assembly (with rear inner bearing race and collapsible spacer) out of gear carrier.

CAUTION:

Do not drop drive pinion assembly.

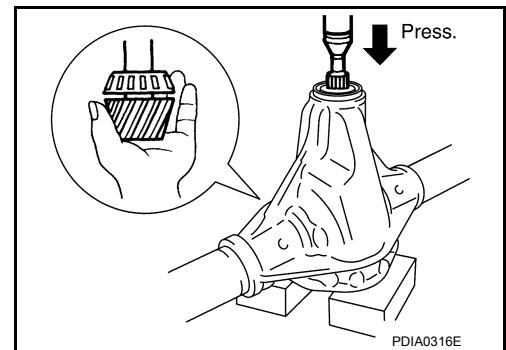

8. Remove collapsible spacer from drive pinion assembly and discard collapsible spacer.

CAUTION:

Do not reuse the collapsible spacer.

INSPECTION AFTER DISASSEMBLY

Clean the disassembled parts. Then inspect the parts for wear or damage. If wear or damage are found, follow the measures below.

REAR FINAL DRIVE ASSEMBLY

< UNIT DISASSEMBLY AND ASSEMBLY >

[REAR FINAL DRIVE: M226]

Drive Pinion and Drive Gear

- If the gear teeth do not mesh or line-up correctly, replace with new rear final drive assembly. Refer to [DLN-258, "Removal and Installation"](#).
- If the gears are worn, cracked, damaged, pitted or chipped (by friction) noticeably, replace with new rear final drive assembly. Refer to [DLN-258, "Removal and Installation"](#).

Bearings

- If bearings are chipped (by friction), pitted, worn, rusted, scratched, or unusual noise is coming from the bearing, replace with new rear final drive assembly. Refer to [DLN-258, "Removal and Installation"](#).

Differential Case Assembly

- If the gears are worn, cracked, damaged, pitted or chipped (by friction) noticeably, replace with new rear final drive assembly. Refer to [DLN-258, "Removal and Installation"](#).
- If the movement is not smooth when pushing cam ring of differential case assembly by hand. Replace with new rear final drive assembly. Refer to [DLN-258, "Removal and Installation"](#).

Companion Flange

- If any chips (about 0.1mm, 0.004 in) or other damage on the companion flange surface which contacts the front oil seal lips are found, replace with new one. Refer to [DLN-259, "Disassembly and Assembly"](#).

ASSEMBLY

Drive Pinion Assembly

1. Install drive pinion front bearing thrust washer.
2. Apply multi-purpose grease to new front oil seal lip. Install front oil seal into gear carrier using Tool.

Tool number : ST15310000 (—)

CAUTION:

- Do not reuse front oil seal.
- Do not incline the new front oil seal when installing.
- Apply multi-purpose grease to the lips of the new front oil seal.

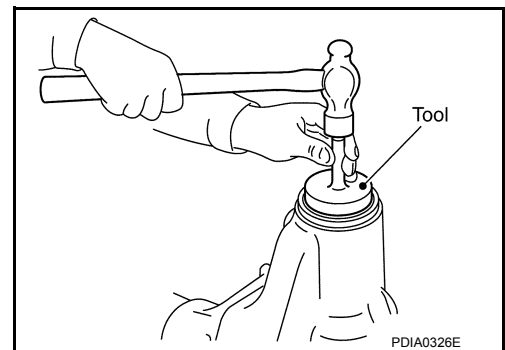

3. Install new collapsible spacer to drive pinion. And then install drive pinion assembly into gear carrier.

CAUTION:

- Do not reuse collapsible spacer.
- Do not damage front oil seal.

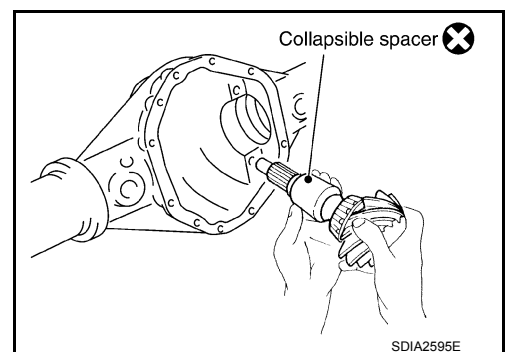

4. Install a new oil seal/dust shield.
5. Install the companion flange onto the drive pinion while aligning the matching marks. Then tap the companion flange using suitable tool.

CAUTION:

Do not damage companion flange or front oil seal.

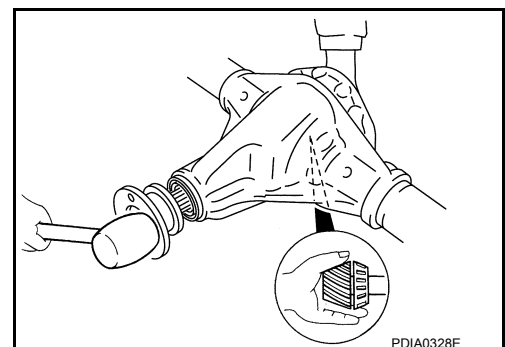

A
B
C
DLN
E
F
G
H
I
J
K
L
M
N
O
P

REAR FINAL DRIVE ASSEMBLY

< UNIT DISASSEMBLY AND ASSEMBLY >

[REAR FINAL DRIVE: M226]

6. Apply anti-corrosive oil to the threads of the drive pinion and the seating surface of the new drive pinion lock nut and new drive pinion lock nut washer. Then adjust the drive pinion lock nut tightening torque using suitable tool (A), and check the drive pinion bearing preload torque using Tool (B). Refer to [DLN-268, "Inspection and Adjustment"](#).

Tool number (B): ST3127S000 (J-25765-A)

CAUTION:

- Do not reuse drive pinion lock nut or drive pinion lock nut washer.
- Apply anti-corrosive oil to the threads of the drive pinion and the seating surface of the new drive pinion lock nut.
- Adjust the drive pinion lock nut tightening torque to the lower limit first. Do not exceed the drive pinion lock nut specified torque.
- If the drive pinion bearing preload torque exceeds the specified value, replace collapsible spacer and tighten it again to adjust. Do not loosen drive pinion lock nut to adjust the drive pinion bearing preload torque.
- After adjustment, rotate drive pinion back and forth 2 to 3 times to check for unusual noise, rotation malfunction, and other malfunctions.

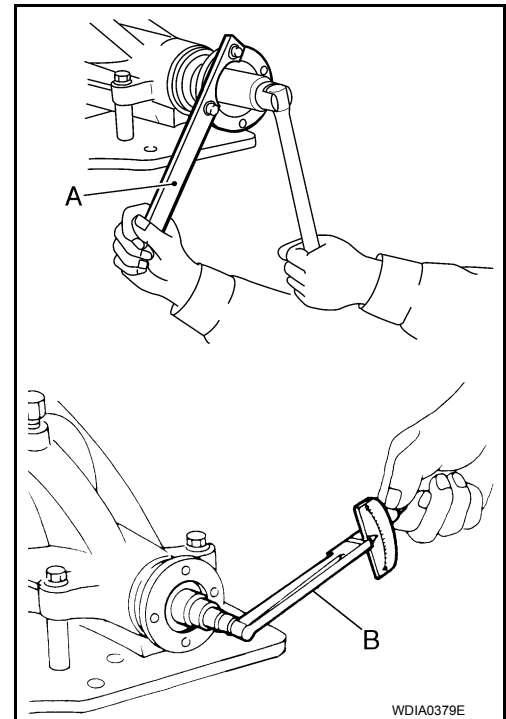

Differential Assembly

1. Apply gear oil to side bearings. Install differential case assembly with side bearing outer races into gear carrier.

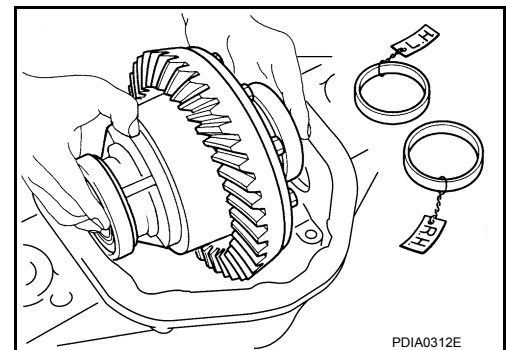

2. Align paint matching mark on side bearing caps with that on gear carrier and install side bearing caps on gear carrier.

CAUTION:

Do not tighten side bearing cap bolts at this point. This allows further tightening of side bearing adjusters.

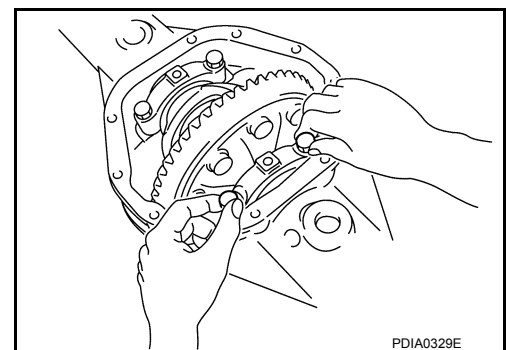

3. Tighten each side bearing adjusters using Tool.

Tool number : — (C - 4164)

- Adjusting backlash of drive gear and drive pinion. Refer to [DLN-268, "Inspection and Adjustment"](#).
- Check total preload. Refer to [DLN-268, "Inspection and Adjustment"](#).
- Check tooth contact. Refer to [DLN-268, "Inspection and Adjustment"](#).

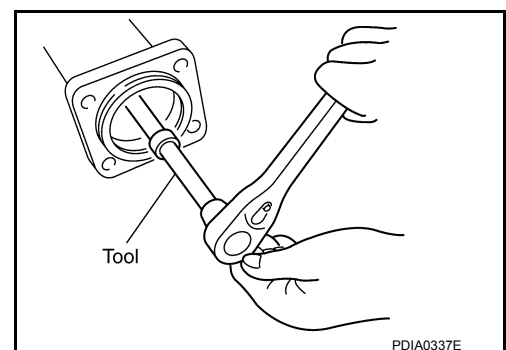

REAR FINAL DRIVE ASSEMBLY

< UNIT DISASSEMBLY AND ASSEMBLY >

[REAR FINAL DRIVE: M226]

4. Apply a bead of sealant to the mating surface of the carrier cover as shown.
 - Use Genuine Silicone RTV or equivalent. Refer to [GI-22. "Recommended Chemical Products and Sealants"](#).
- CAUTION:**
Remove any old sealant adhering to the mating surfaces. Also remove any moisture, oil, or foreign material adhering to the application and mating surfaces.
5. Install the carrier cover to the gear carrier. Tighten the bolts to the specified torque.

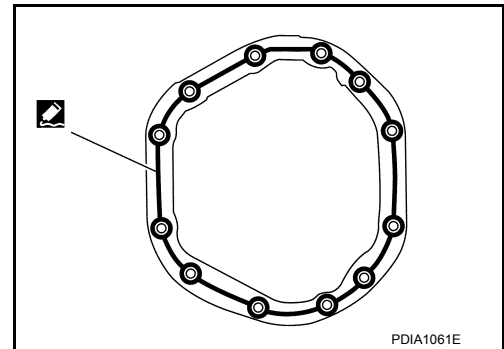

A
B
C

DLN

E
F
G
H
I
J
K
L
M
N
O
P

SERVICE DATA AND SPECIFICATIONS (SDS)

< SERVICE DATA AND SPECIFICATIONS (SDS)

[REAR FINAL DRIVE: M226]

SERVICE DATA AND SPECIFICATIONS (SDS)

SERVICE DATA AND SPECIFICATIONS (SDS)

General Specification

INFOID:000000007324029

2WD MODELS

Applied model	VQ40DE
	6M/T
Final drive model	M226
Gear ratio	3.538
Number of teeth (Drive gear / drive pinion)	46/13
Oil capacity (Approx.)	2.01 ℓ (4-1/4 US pt, 3-1/2 Imp pt)
Drive pinion adjustment spacer type	Collapsible

4WD MODELS

Applied model	VQ40DE	
	6M/T	
Body type	King cab	Crew cab
Final drive model	M226	
Gear ratio	3.538	3.692
Number of teeth (Drive gear / drive pinion)	46/13	48/13
Oil capacity (Approx.)	2.01 ℓ (4-1/4 US pt, 3-1/2 Imp pt)	
Drive pinion adjustment spacer type	Collapsible	

Inspection and Adjustment

INFOID:000000007324030

DIFFERENTIAL SIDE GEAR CLEARANCE

Unit: mm (in)

Item	Standard
Side gear back clearance (Clearance between side gear and differential case for adjusting side gear backlash)	0.305 (0.0120) or less. (Each gear should rotate smoothly without excessive resistance during differential motion.)

PRELOAD TORQUE

Unit: N·m (kg·m, in·lb)

Item	Specification
Drive pinion bearing preload torque	1.7 - 3.1 (0.18 - 0.31, 15 - 27)
Total preload torque (Total preload torque = drive pinion bearing preload torque + Side bearing preload torque)	2.49 - 4.57 (0.26 - 0.46, 22 - 40)

BACKLASH

Unit: mm (in)

Item	Standard
Drive gear to drive pinion gear	0.12 - 0.20 (0.0050 - 0.0079)

COMPANION FLANGE RUNOUT

Unit: mm (in)

SERVICE DATA AND SPECIFICATIONS (SDS)

< SERVICE DATA AND SPECIFICATIONS (SDS)

[REAR FINAL DRIVE: M226]

Item	Runout limit
Companion flange face	0.13 (0.0051) or less
Companion flange inner side	

A

B

C

DLN

E

F

G

H

I

J

K

L

M

N

O

P

DIAGNOSIS AND REPAIR WORKFLOW

< BASIC INSPECTION >

[REAR FINAL DRIVE: M226 (ELD)]

BASIC INSPECTION

DIAGNOSIS AND REPAIR WORKFLOW

Work Flow

INFOID:000000007324031

OVERALL SEQUENCE

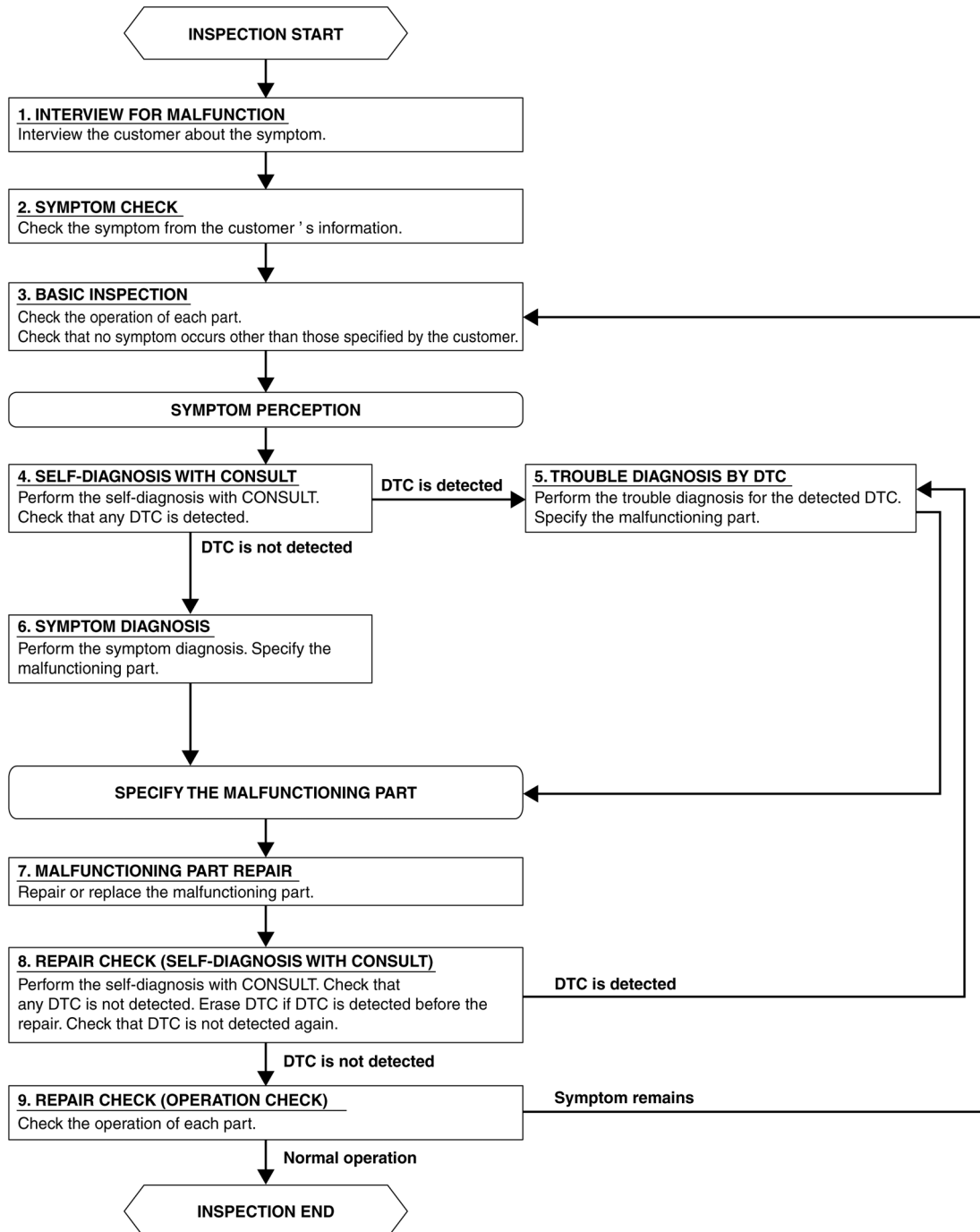

AWEIA0214GB

DETAILED FLOW

DIAGNOSIS AND REPAIR WORKFLOW

< BASIC INSPECTION >

[REAR FINAL DRIVE: M226 (ELD)]

1. INTERVIEW FOR MALFUNCTION

Interview the customer about the symptom.

>> GO TO 2

2. SYMPTOM CHECK

Verify the symptom from the customer's information.

>> GO TO 3

3. BASIC INSPECTION

Check the operation of each part. Check that no symptoms occur other than those specified by the customer.

>> GO TO 4

4. SELF-DIAGNOSIS WITH CONSULT

Perform the self diagnosis with CONSULT. Check that any DTC is detected.

Is any DTC detected?

YES >> GO TO 5

NO >> GO TO 6

5. TROUBLE DIAGNOSIS BY DTC

Perform the trouble diagnosis for the detected DTC. Specify the malfunctioning part.

>> GO TO 7

6. SYMPTOM DIAGNOSIS

Perform the symptom diagnosis. Specify the malfunctioning part.

>> GO TO 7

7. MALFUNCTIONING PART REPAIR

Repair or replace the malfunctioning part.

>> GO TO 8

8. REPAIR CHECK (SELF-DIAGNOSIS WITH CONSULT)

Perform the self diagnosis with CONSULT. Verified that no DTCs are detected. Erase all DTCs detected prior to the repair. Verify that DTC is not detected again.

Is any DTC detected?

YES >> GO TO 5

NO >> GO TO 9

9. REPAIR CHECK (OPERATION CHECK)

Check the operation of each part.

Does it operate normally?

YES >> Inspection End.

NO >> GO TO 3

A
B
C
DLN
E
F
G
H
I
J
K
L
M
N
O
P

DIFFERENTIAL LOCK SYSTEM

< SYSTEM DESCRIPTION >

[REAR FINAL DRIVE: M226 (ELD)]

SYSTEM DESCRIPTION

DIFFERENTIAL LOCK SYSTEM

Cross-Sectional View

INFOID:000000007324032

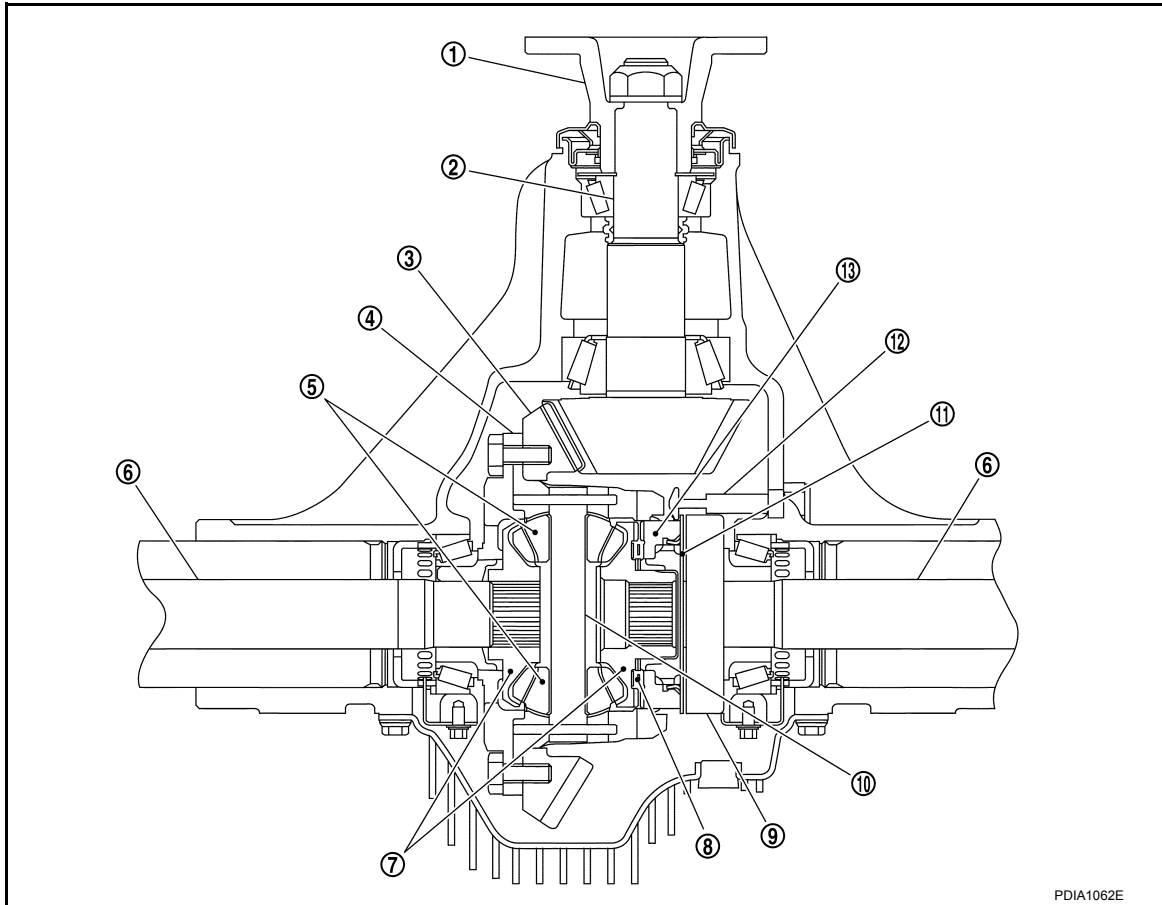

PDIA1062E

- | | | |
|-----------------------|---------------------|---------------------------------------|
| 1. Companion flange | 2. Drive pinion | 3. Drive gear |
| 4. Differential case | 5. Pinion mate gear | 6. Axle shaft |
| 7. Side gear | 8. Spring | 9. Differential lock solenoid |
| 10. Pinion mate shaft | 11. Pressure plate | 12. Differential lock position switch |
| 13. Cam ring | | |

DIFFERENTIAL LOCK SYSTEM

< SYSTEM DESCRIPTION >

[REAR FINAL DRIVE: M226 (ELD)]

System Diagram

INFOID:000000007324033

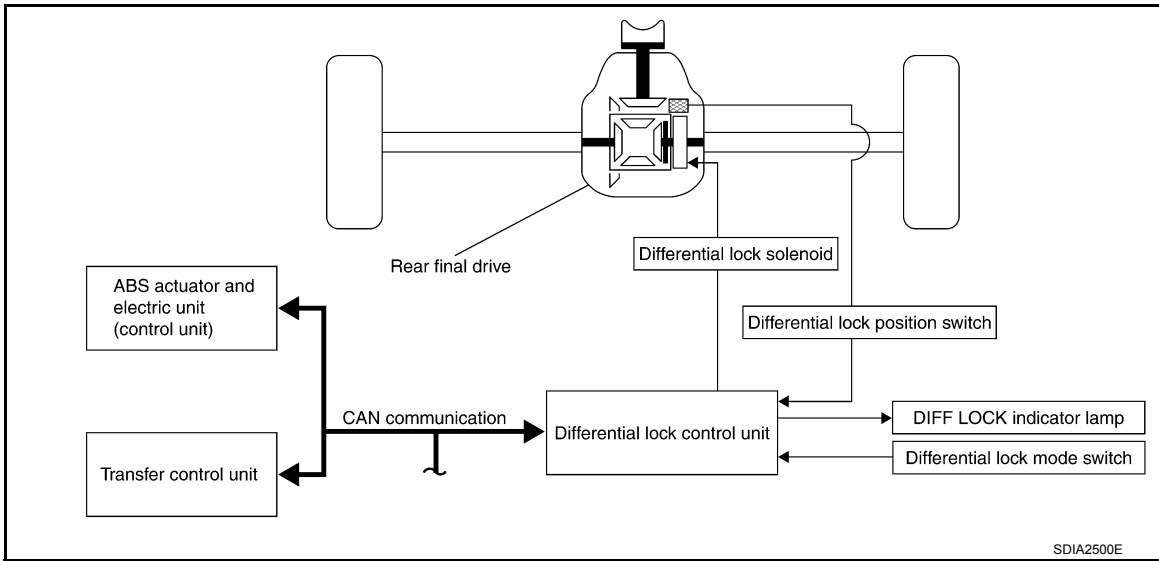

A
B
C
DLN

System Description

INFOID:000000007324034

The differential lock system consists of the following components

- Differential lock control unit
- Differential lock mode switch
- Differential lock position switch
- Differential lock solenoid
- ABS actuator and electric unit (control unit)
- Transfer control unit

DIFFERENTIAL LOCK SYSTEM OPERATION

When the differential lock mode switch is in the LOCK position, a signal is sent to the differential lock control unit. The differential lock control unit monitors input from the ABS actuator and electric unit (vehicle speed and VDC operation) and the transfer control unit (4WD shift switch). If conditions are set, the differential lock control unit provides power and ground to the differential lock solenoid to lock the differential. The differential lock position switch provides feedback to the differential lock control unit as to whether the lock is engaged based on pressure plate position. The differential lock control unit provides ground to the DIFF LOCK indicator lamp to activate the lamp. Refer to the Owner's Manual for differential lock system operating instructions.

As a fail-safe function, the differential lock disengages when a malfunction is detected in the differential lock system. Self-diagnostics can be performed using CONSULT. Refer to [DLN-276, "DIFFERENTIAL LOCK CONTROL UNIT : CONSULT Function \(DIFF LOCK\)"](#).

DIFFERENTIAL LOCK OPERATION

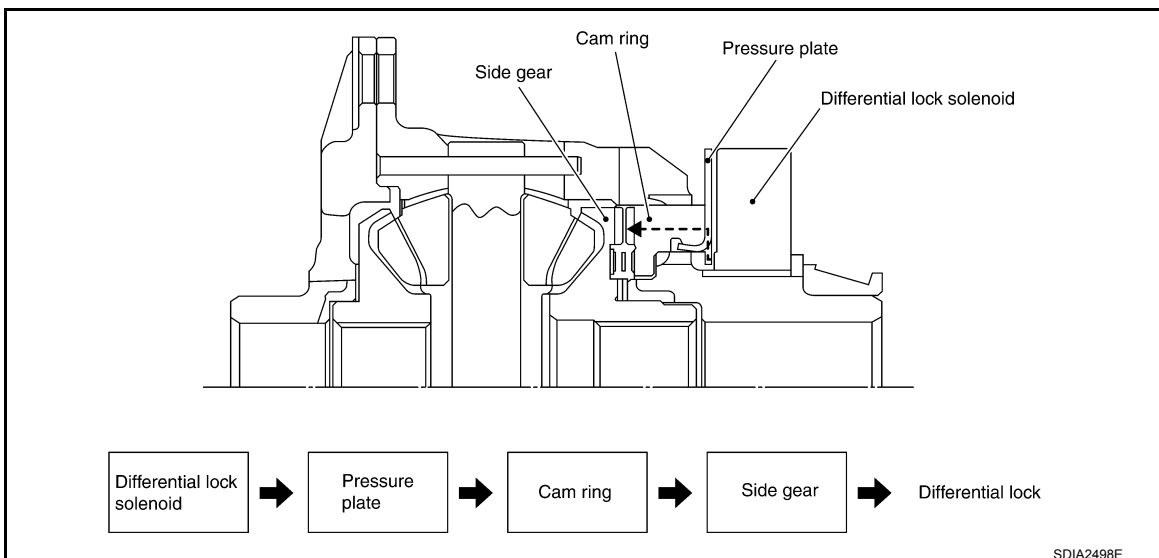

E
F
G
H
I
J
K
L
M
N
O
P

DIFFERENTIAL LOCK SYSTEM

< SYSTEM DESCRIPTION >

[REAR FINAL DRIVE: M226 (ELD)]

1. Differential lock solenoid operates pressure plate.
2. Pressure plate presses cam ring.
3. Engage cam ring and side gear, and the differential is locked.

DIFFERENTIAL LOCK INDICATOR LAMP OPERATION

Condition	DIFF LOCK indicator lamp
Differential lock/unlock	ON/OFF
Differential lock standby condition	Flashing once every 2 seconds
Differential lock system malfunction	OFF (even if differential lock mode switch is in LOCK position)

NOTE:

The differential lock standby condition is the time where the differential lock mode switch is in the LOCK position and the differential is unlocked.

Component Parts Location

INFOID:000000007324035

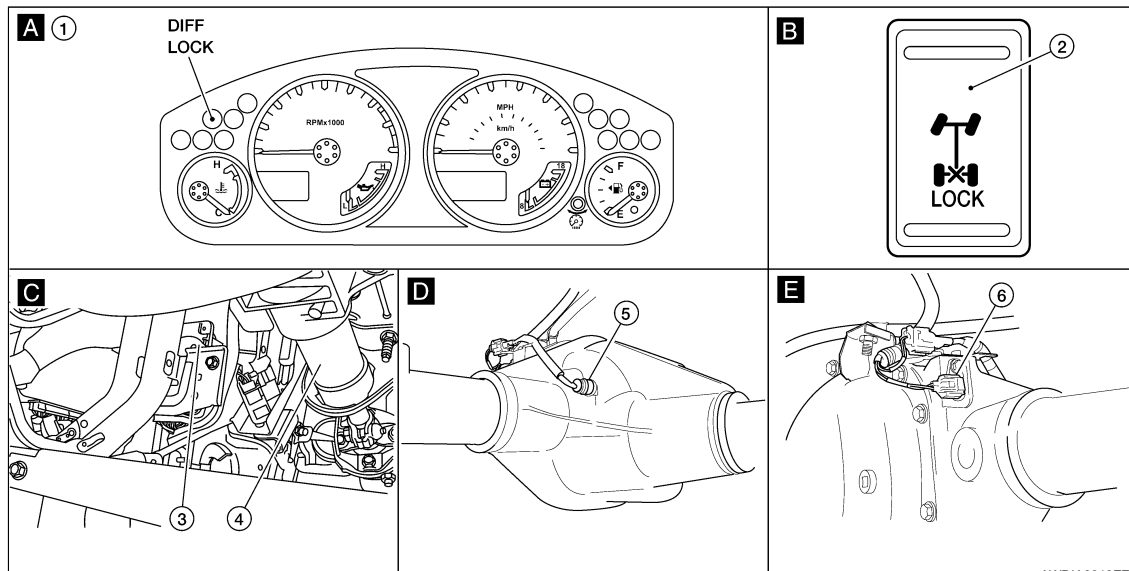
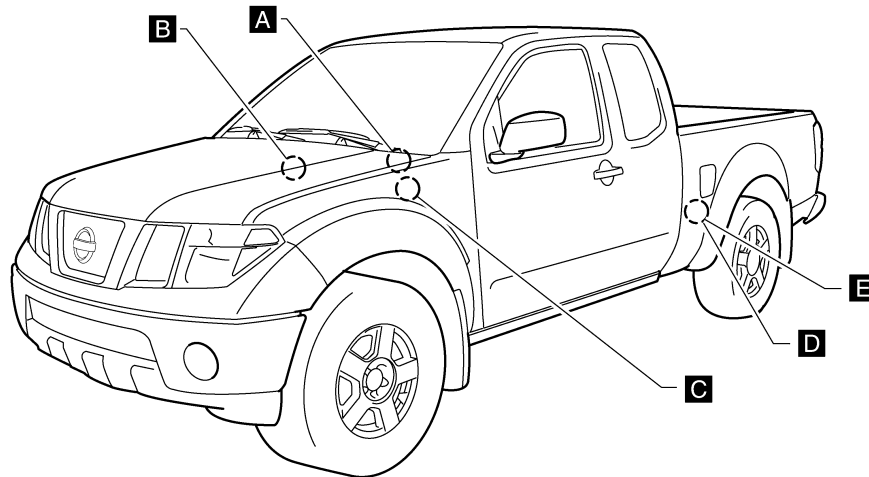

- | | | |
|--------------------------|---|---|
| 1. Combination meter M24 | 2. Differential lock mode switch M149 | 3. Differential lock control unit M70 (view with lower instrument panel LH removed) |
| 4. Steering column | 5. Differential lock position switch C116 | 6. Differential lock solenoid C117 |

DIFFERENTIAL LOCK SYSTEM

< SYSTEM DESCRIPTION >

[REAR FINAL DRIVE: M226 (ELD)]

Component Description

INFOID:000000007324036

Component	Function
Differential lock control unit	<ul style="list-style-type: none"> • Controls differential lock solenoid to lock/unlock the differential. • As a fail-safe function, the differential lock disengages when a malfunction is detected within the differential lock system.
Differential lock solenoid	Controls pressure plate operation when provided power and ground from the differential lock control unit.
Differential lock position switch	Detects differential lock/unlock condition based on the position of the pressure plate.
Differential lock mode switch	Allows driver input for differential LOCK/UNLOCK to the differential lock control unit.
DIFF LOCK indicator lamp	Illuminates to indicate the differential lock is locked or in standby condition.
ABS actuator and electric unit (control unit)	Transmits the following signals via CAN communication to the differential lock control unit. <ul style="list-style-type: none"> • Vehicle speed signal • VDC operation signal (A/T models)
Transfer control unit (with 4-wheel drive)	Transmits the 4WD shift switch signal via CAN communication to the differential lock control unit.

A
B
C
DLN
E
F
G
H
I
J
K
L
M
N
O
P

DIAGNOSIS SYSTEM (DIFFERENTIAL LOCK CONTROL UNIT)

< SYSTEM DESCRIPTION >

[REAR FINAL DRIVE: M226 (ELD)]

DIAGNOSIS SYSTEM (DIFFERENTIAL LOCK CONTROL UNIT)

DIFFERENTIAL LOCK CONTROL UNIT

DIFFERENTIAL LOCK CONTROL UNIT : CONSULT Function (DIFF LOCK)

INFOID:000000007324037

APPLICATION ITEM

CONSULT performs the following functions via DDL2 communication with differential lock control unit.

Direct Diagnostic Mode	Description
Ecu Identification	The differential lock control unit part number is displayed.
Self Diagnostic Result	The differential lock control unit self diagnostic results are displayed.
Data Monitor	The differential lock control unit input/output data is displayed in real time.
CAN Diag Support Mntr	The result of transmit/receive diagnosis of CAN communication is displayed.

SELF DIAGNOSTIC RESULT

Refer to [DLN-300, "DTC Index"](#).

DATA MONITOR

Monitor Item [Unit]	ECU INPUT SIGNALS	MAIN SIGNALS	Description
BATTERY VOLT [V]	x	x	Indicates voltage supply to differential lock control unit.
4WD MODE [2H/4H/4Lo]	x	x	Indicates condition of 4WD shift switch signal received from transfer control unit on CAN communication line.
VHCL S/SEN-R [km/h] or [mph]	x	–	Indicates right rear wheel speed signal received from ABS actuator and electric unit (control unit) on CAN communication line (approx. vehicle speed).
VHCL S/SEN-L [km/h] or [mph]	x	–	Indicates left rear wheel speed signal received from ABS actuator and electric unit (control unit) on CAN communication line (approx. vehicle speed).
VHCL S/SEN-RL [km/h] or [mph]	x	x	Indicates average of rear wheel speed signal (left and right) received from ABS actuator and electric unit (control unit) on CAN communication line.
D-LOCK SW SIG [On/Off]	x	x	Indicates condition of differential lock mode switch.
D-LOCK SIG [On/Off]	x	x	Indicates condition of differential lock.
RELAY ON [On/Off]	x	x	Indicates operating condition of differential lock solenoid relay (integrated in differential lock control unit).
RELAY MTR [On/Off]	x	x	Indicates control status of differential lock solenoid relay (integrated in differential lock control unit).
SOL MTR [On/Off]	x	x	Indicates condition of differential lock solenoid.
IND MTR [On/Off]	x	x	Indicates condition of DIFF LOCK indicator lamp.
D-LOCK POS SW [On/Off]	x	x	Indicates condition of differential lock position switch

NOISE, VIBRATION AND HARSHNESS (NVH) TROUBLESHOOTING

< SYSTEM DESCRIPTION >

[REAR FINAL DRIVE: M226 (ELD)]

NOISE, VIBRATION AND HARSHNESS (NVH) TROUBLESHOOTING

NVH Troubleshooting Chart

INFOID:000000007324038

Use the chart below to help you find the cause of the symptom. If necessary, repair or replace these parts.

Symptom	Noise																	
Reference page			DLN-324	DLN-324	DLN-324	DLN-322	DLN-324	MA-18	DLN-135. "NVH Troubleshooting Chart"	DLN-175. "NVH Troubleshooting Chart"	DLN-164. "NVH Troubleshooting Chart"	RAX-17. "NVH Troubleshooting Chart"	RSU-4. "NVH Troubleshooting Chart"	WT-43. "NVH Troubleshooting Chart"	WT-43. "NVH Troubleshooting Chart"	RAX-17. "NVH Troubleshooting Chart"	BR-5. "NVH Troubleshooting Chart"	ST-5. "NVH Troubleshooting Chart"
Possible cause and SUSPECTED PARTS		Gear tooth rough	Gear contact improper	Tooth surfaces worn	Backlash incorrect	Companion flange excessive runout	Gear oil improper	PROPELLER SHAFT	REAR AXLE	REAR SUSPENSION	TIRES	ROAD WHEEL	AXLE SHAFT	BRAKES	STEERING			
		x	x	x	x	x	x	x	x	x	x	x	x	x	x	x		

x: Applicable

A
B
C
DLN
E
F
G
H
I
J
K
L
M
N
O
P

U1000 CAN COMM CIRCUIT

< DTC/CIRCUIT DIAGNOSIS >

[REAR FINAL DRIVE: M226 (ELD)]

DTC/CIRCUIT DIAGNOSIS

U1000 CAN COMM CIRCUIT

Description

INFOID:000000007324039

CAN (Controller Area Network) is a serial communication line for real time application. It is an on-vehicle multiplex communication line with high data communication speed and excellent error detection ability. Many electronic control units are equipped onto a vehicle and each control unit shares information and links with other control units during operation (not independent). In CAN communication, control units are connected with 2 communication lines (CAN-H, CAN-L) allowing a high rate of information transmission with less wiring. Each control unit transmits/receives data but selectively reads required data only.

CAN Communication Signal Chart. Refer to [LAN-48, "CAN Communication Signal Chart"](#).

DTC Logic

INFOID:000000007324040

DTC DETECTION LOGIC

DTC	Display contents of CONSULT	Diagnostic item is detected when ...	Probable malfunction location
U1000	CAN COMM CIRCUIT	When differential lock control unit is not transmitting or receiving CAN communication signal for 2 seconds or more.	CAN communication system

Diagnosis Procedure

INFOID:000000007324041

1. PERFORM SELF DIAGNOSTIC

1. Turn ignition switch ON and wait for 2 seconds or more.
2. Check "Self Diagnostic Result" of differential lock control unit.

Is "CAN COMM CIRCUIT" displayed?

- YES >> Refer to [LAN-14, "Trouble Diagnosis Flow Chart"](#).
NO >> Refer to [GI-46, "Intermittent Incident"](#).

P1833 INITIAL START

< DTC/CIRCUIT DIAGNOSIS >

[REAR FINAL DRIVE: M226 (ELD)]

P1833 INITIAL START

Description

INFOID:000000007324042

Self-diagnosis memory function was suspended due to low battery voltage at the differential lock control unit.

DTC Logic

INFOID:000000007324043

DTC	Display contents of CONSULT	DTC Detection Condition	Action to take
P1833	INITIAL START [P1833]	Low battery voltage available to the differential lock control unit.	Check differential lock control unit power supply and ground circuit. Refer to DLN-279 . "Diagnosis Procedure"

Diagnosis Procedure

INFOID:000000007324044

Regarding Wiring Diagram information, refer to [DLN-301](#), "Wiring Diagram".

1. CHECK DIFFERENTIAL LOCK CONTROL UNIT POWER SUPPLY

- Turn ignition switch OFF.
- Disconnect differential lock control unit harness connector.
- Turn ignition switch ON.
- Check voltage between differential lock control unit harness connector M70 terminals 1, 2, 15 and ground.

(+) Connector		Terminal	(-) Ground	Voltage (Approx.)
M70		1	Ground	Battery voltage
		2		
		15		

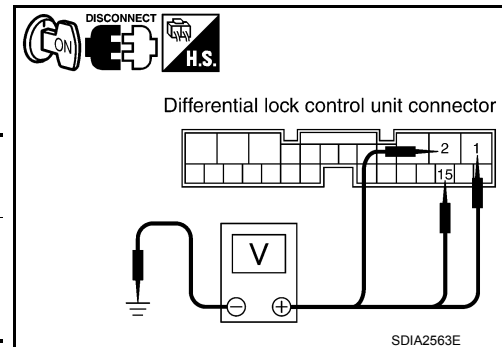

Is the inspection result normal?

- YES >> GO TO 2.
 NO >> Check fuse. Repair harness or connectors.

2. CHECK DIFFERENTIAL LOCK CONTROL UNIT GROUND CIRCUIT

- Turn ignition switch OFF.
- Check continuity between differential lock control unit harness connector M70 terminals 3, 10 and ground.

Connector	Terminal	— Ground	Continuity
M70	3	Ground	Yes
	10		

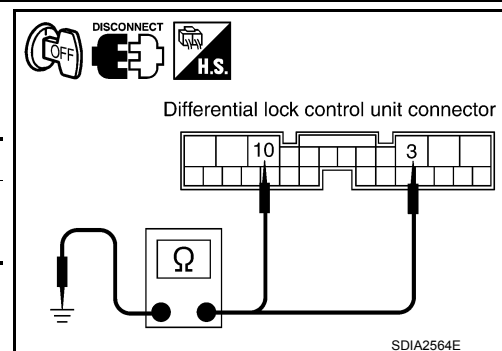

Is the inspection result normal?

- YES >> Power and ground supply is normal.
 NO >> Repair harness or connectors.

P1834 CONTROL UNIT 1

< DTC/CIRCUIT DIAGNOSIS >

[REAR FINAL DRIVE: M226 (ELD)]

P1834 CONTROL UNIT 1

Description

INFOID:000000007324045

Replace the differential lock control unit if this DTC is displayed. Refer to [DLN-314, "Removal and Installation"](#).

DTC Logic

INFOID:000000007324046

DTC	Display contents of CONSULT	DTC Detection Condition	Action to take
P1834	CONTROL UNIT 1 [P1834]	A malfunction is detected in the memory (RAM) of the differential lock control unit.	Replace differential lock control unit. Refer to DLN-314, "Removal and Installation" .

P1835 CONTROL UNIT 2

< DTC/CIRCUIT DIAGNOSIS >

[REAR FINAL DRIVE: M226 (ELD)]

P1835 CONTROL UNIT 2

Description

INFOID:000000007324047

Replace the differential lock control unit if this DTC is displayed. Refer to [DLN-314, "Removal and Installation"](#).

DTC Logic

INFOID:000000007324048

DTC	Display contents of CONSULT	DTC Detection Condition	Action to take
P1835	CONTROL UNIT 2 [P1835]	A malfunction is detected in the memory (ROM) of the differential lock control unit.	Replace differential lock control unit. Refer to DLN-314, "Removal and Installation" .

A
B
C
DLN
E
F
G
H
I
J
K
L
M
N
O
P

P1836 CONTROL UNIT 3

< DTC/CIRCUIT DIAGNOSIS >

[REAR FINAL DRIVE: M226 (ELD)]

P1836 CONTROL UNIT 3

Description

INFOID:000000007324049

Replace the differential lock control unit if this DTC is displayed. Refer to [DLN-314, "Removal and Installation"](#).

DTC Logic

INFOID:000000007324050

DTC	Display contents of CONSULT	DTC Detection Condition	Action to take
P1836	CONTROL UNIT 3 [P1836]	A malfunction is detected in the memory (EEPROM) of the differential lock control unit.	Replace differential lock control unit. Refer to DLN-314, "Removal and Installation" .

P1837 CONTROL UNIT 4

< DTC/CIRCUIT DIAGNOSIS >

[REAR FINAL DRIVE: M226 (ELD)]

P1837 CONTROL UNIT 4

Description

INFOID:000000007324051

Replace the differential lock control unit if this DTC is displayed. Refer to [DLN-314, "Removal and Installation"](#).

DTC Logic

INFOID:000000007324052

DTC	Display contents of CONSULT	DTC Detection Condition	Action to take
P1837	CONTROL UNIT 4 [P1837]	The AD converter system of the differential lock control unit is malfunctioning.	Replace differential lock control unit. Refer to DLN-314, "Removal and Installation" .

A
B
C
DLN
E
F
G
H
I
J
K
L
M
N
O
P

P1838 ON SWITCH

< DTC/CIRCUIT DIAGNOSIS >

[REAR FINAL DRIVE: M226 (ELD)]

P1838 ON SWITCH

Description

INFOID:000000007324053

The differential lock mode switch sends differential lock ON/OFF request signals to the differential lock control unit.

DTC Logic

INFOID:000000007324054

DTC	Display contents of CONSULT	DTC Detection Condition	Action to take
P1838	ON SW [P1838]	Two switch inputs were simultaneously detected due to a short circuit in the differential lock mode switch.	Inspect the differential lock mode switch. Refer to DLN-284 , "Diagnosis Procedure".

Diagnosis Procedure

INFOID:000000007324055

Regarding Wiring Diagram information, refer to [DLN-301](#), "Wiring Diagram".

1. CHECK DIFFERENTIAL LOCK MODE SWITCH OPERATION

1. Turn ignition switch ON.
2. Using CONSULT, select "D-LOCK SW SIG" of DIFF LOCK data monitor items.
3. While operating the differential lock mode switch, check that the display value changes between ON/OFF.

Switch ON

Display item ON

Switch OFF

Display item OFF

Is the inspection result normal?

- YES >> Differential lock mode switch is operating properly.
NO >> GO TO 2.

2. CHECK DIFFERENTIAL LOCK MODE SWITCH POWER SUPPLY CIRCUIT

1. Disconnect differential lock mode switch harness connector.
2. Turn ignition switch ON.
3. Check voltage between differential lock mode switch harness connector M149 terminal 3 and ground.

(+)		(-)	Voltage (Approx.)
Connector	Terminal		
M149	3	Ground	Battery voltage

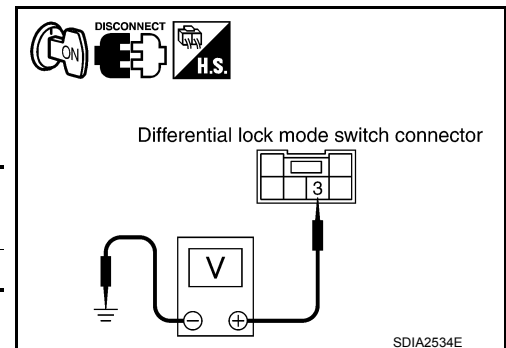

Is the inspection result normal?

- YES >> GO TO 3.
NO >> Repair harness or connector.

3. CHECK DIFFERENTIAL LOCK MODE SWITCH SIGNAL

P1838 ON SWITCH

< DTC/CIRCUIT DIAGNOSIS >

[REAR FINAL DRIVE: M226 (ELD)]

1. Turn ignition switch OFF.
2. Connect differential lock mode switch harness connector.
3. Check voltage between differential lock control unit harness connector M70 terminals 9, 22 and ground.

(+)		(-)	Differential lock mode switch	Voltage (Approx.)
Connector	Terminal			
M70	9	Ground	ON	Battery voltage
			OFF	0V
	22		ON	0V
			OFF	Battery voltage

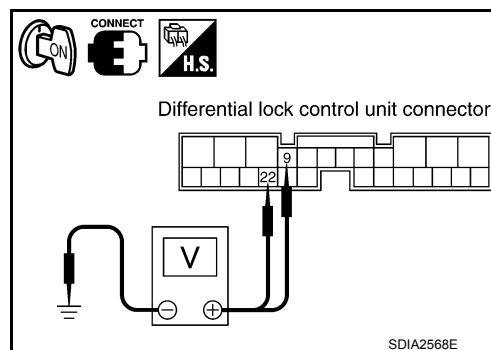

Is the inspection result normal?

- YES >> Replace the differential lock control unit. Refer to [DLN-314. "Removal and Installation"](#).
 NO >> GO TO 4.

4. CHECK DIFFERENTIAL LOCK MODE SWITCH

1. Turn ignition switch OFF.
2. Disconnect differential lock mode switch harness connector.
3. Operate differential lock mode switch and check continuity between differential lock mode switch terminals.

Terminals	Differential lock mode switch	Continuity
1 - 3	ON	No
	OFF	Yes
2 - 3	ON	Yes
	OFF	No

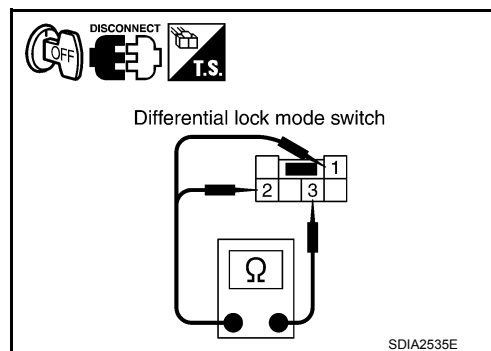

Is the inspection result normal?

- YES >> GO TO 5.
 NO >> Replace differential lock mode switch.

5. CHECK HARNESS BETWEEN DIFFERENTIAL LOCK CONTROL UNIT AND DIFFERENTIAL LOCK MODE SWITCH

1. Check continuity between differential lock control unit harness connector M70 (A) terminals 9, 22 and differential lock mode switch harness connector M149 (B) terminals 2, 1.

Connector	Terminal	Connector	Terminal	Continuity
M70 (A)	9	M149 (B)	2	Yes
	22		1	

2. Check continuity between differential lock control unit harness connector M70 (A) terminals 9, 22 and ground.

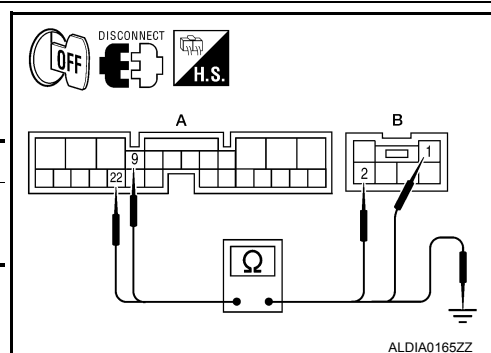

Connector	Terminal	Ground	Continuity
M70 (A)	9		No
	22	No	

Is the inspection result normal?

- YES >> Replace the differential lock control unit. Refer to [DLN-314. "Removal and Installation"](#).
 NO >> Repair harness or connector.

P1839 POSITION SWITCH ON

< DTC/CIRCUIT DIAGNOSIS >

[REAR FINAL DRIVE: M226 (ELD)]

P1839 POSITION SWITCH ON

Description

INFOID:000000007324056

The differential lock position switch sends a signal to the differential lock control unit when the differential lock is engaged. The differential lock control unit monitors the left and right rear wheel speed sensor signals to determine wheel slippage. When the differential lock is engaged the left and right rear wheel speed sensor signals should match.

DTC Logic

INFOID:000000007324057

DTC	Display contents of CONSULT	DTC Detection Condition	Action to take
P1839	POSI SW ON [P1839]	The differential lock position switch is ON indicating the differential is locked, but the differential lock control unit detects a difference between left and right rear wheel speeds.	Inspect the differential lock position switch. Refer to DLN-286, "Diagnosis Procedure" .

Diagnosis Procedure

INFOID:000000007324058

Regarding Wiring Diagram information, refer to [DLN-301, "Wiring Diagram"](#).

1. CHECK DIFFERENTIAL LOCK POSITION SWITCH SIGNAL

1. Start engine.
2. Using CONSULT, select "D-LOCK POS SW SIG" of DIFF LOCK data monitor.
3. Activate the differential lock according to the directions listed in the table and monitor the display value.

Monitor item	Condition	Display value
D-LOCK POS SW SIG	<ul style="list-style-type: none"> • Vehicle stopped • Engine running • VDC OFF switch (A/T models): ON • 4WD shift switch: 4LO 	Differential lock mode switch: ON (DIFF LOCK indicator lamp: ON)
		Differential lock mode switch: OFF (DIFF LOCK indicator lamp: OFF)

Is the inspection result normal?

- YES >> Differential lock position switch is operating normally.
 NO >> GO TO 2.

2. CHECK DIFFERENTIAL LOCK POSITION SWITCH

1. Disconnect differential lock position switch harness connector.
2. Turn ignition switch ON.
3. Select "D-LOCK POS SW SIG" of DIFF LOCK data monitor.
4. Monitor the display value while connecting and disconnecting a jumper wire between differential lock position switch harness connector C116 terminals 1 and 3.

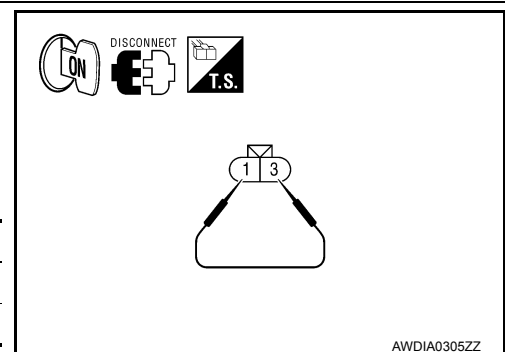

Monitor item	Condition	Display value
D-LOCK POS SW SIG	Jumper wire connected	ON
	Jumper wire disconnected	OFF

Is the inspection result normal?

- YES >> Check the mechanical operation of the differential lock. Replace the differential lock position switch. Refer to [DLN-315, "Removal and Installation"](#).
 NO >> GO TO 3.

3. CHECK DIFFERENTIAL LOCK POSITION SWITCH VOLTAGE

P1839 POSITION SWITCH ON

[REAR FINAL DRIVE: M226 (ELD)]

< DTC/CIRCUIT DIAGNOSIS >

Check voltage between differential lock position switch harness connector C116 terminal 3 and ground.

(+)		(-)	Voltage (Approx.)
Connector	Terminal		
C116	3	Ground	Battery voltage

Is the inspection result normal?

- YES >> GO TO 4.
- NO >> GO TO 5.

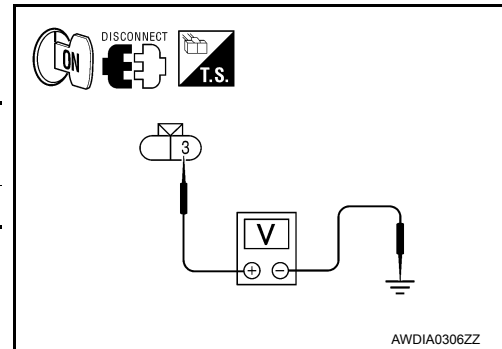

4. CHECK GROUND CIRCUIT

- Turn ignition switch OFF.
- Check continuity between differential lock position switch harness connector C116 terminal 1 and ground.

Connector	Terminal	—	Continuity
C116	1	Ground	Yes

Is the inspection result normal?

- YES >> Replace the differential lock control unit. Refer to [DLN-314. "Removal and Installation"](#).
- NO >> Repair harness or connector.

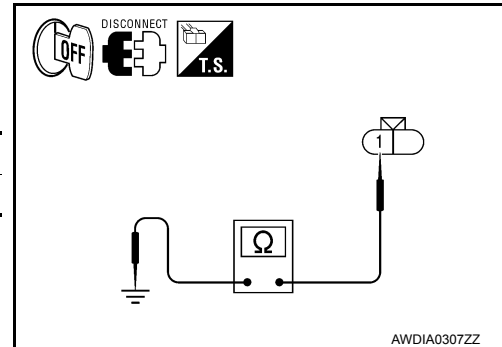

5. CHECK HARNESS BETWEEN DIFFERENTIAL LOCK CONTROL UNIT AND DIFFERENTIAL LOCK POSITION SWITCH

- Turn ignition switch OFF.
- Disconnect differential lock control unit harness connector.
- Check continuity between differential lock control unit harness connector M70 (A) terminal 20 and differential lock position switch harness connector C116 (B) terminal 3.

Connector	Terminal	Connector	Terminal	Continuity
M70 (A)	20	C116 (B)	3	Yes

- Check continuity between differential lock control unit harness connector M70 (A) terminal 20 and ground.

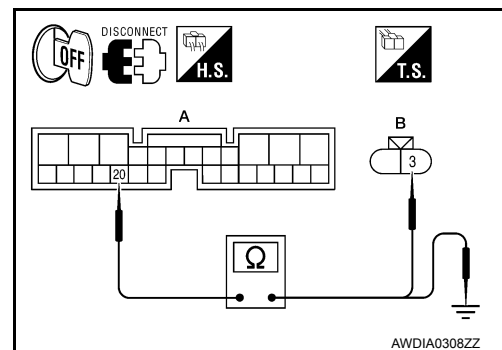

Connector	Terminal	Ground	Continuity
M70 (A)	20		No

Is the inspection result normal?

- YES >> Replace differential lock control unit. Refer to [DLN-314. "Removal and Installation"](#).
- NO >> Repair harness or connector.

A
B
C
DLN
E
F
G
H
I
J
K
L
M
N
O
P

P1844 RELAY

< DTC/CIRCUIT DIAGNOSIS >

[REAR FINAL DRIVE: M226 (ELD)]

P1844 RELAY

Description

INFOID:000000007324059

The differential lock solenoid relay is an integral part of the differential lock control unit.

DTC Logic

INFOID:000000007324061

DTC	Display contents of CONSULT	DTC Detection Condition	Action to take
P1844	RELAY [P1844]	The differential lock control unit relay monitor did not detect expected voltage at the relay.	Inspect differential lock control unit relay power and ground supply circuit. Refer to DLN-288, "Diagnosis Procedure" .

Diagnosis Procedure

INFOID:000000007324061

Regarding Wiring Diagram information, refer to [DLN-301, "Wiring Diagram"](#).

1. CHECK DIFFERENTIAL LOCK CONTROL UNIT POWER SUPPLY

1. Turn ignition switch OFF.
2. Disconnect differential lock control unit harness connector.
3. Turn ignition switch ON.
4. Check voltage between differential lock control unit harness connector M70 terminals 1, 2, 15 and ground.

(+)		(-)	Voltage (Approx.)
Connector	Terminal		
M70	1	Ground	Battery voltage
	2		
	15		

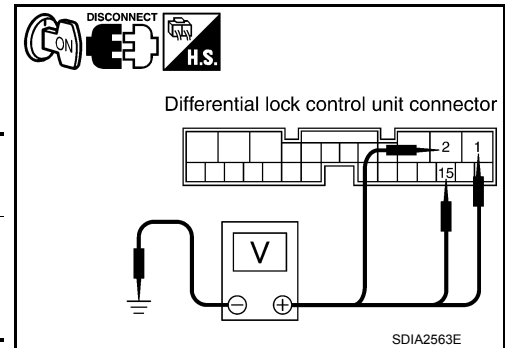

Is the inspection result normal?

- YES >> GO TO 2.
 NO >> Check fuse. Repair harness or connectors.

2. CHECK DIFFERENTIAL LOCK CONTROL UNIT GROUND CIRCUIT

1. Turn ignition switch OFF.
2. Check continuity between differential lock control unit harness connector M70 terminals 3, 10 and ground.

Connector	Terminal	—	Continuity
M70	3	Ground	Yes
	10		

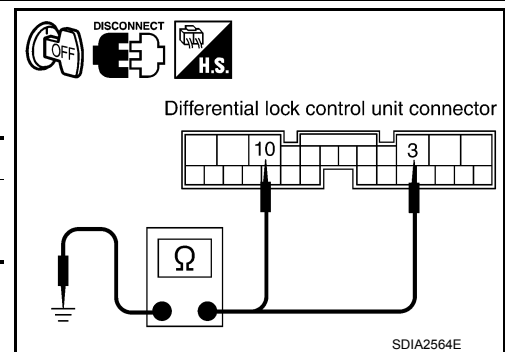

Is the inspection result normal?

- YES >> Replace the differential lock control unit. Refer to [DLN-314, "Removal and Installation"](#).
 NO >> Repair harness or connectors.

P1847 SOLENOID CIRCUIT

< DTC/CIRCUIT DIAGNOSIS >

[REAR FINAL DRIVE: M226 (ELD)]

P1847 SOLENOID CIRCUIT

Description

INFOID:000000007324062

Replace the differential lock control unit if this DTC is displayed. Refer to [DLN-314. "Removal and Installation"](#)

DTC Logic

INFOID:000000007324063

DTC	Display contents of CONSULT	DTC Detection Condition	Action to take
P1847	SOL CIRCUIT [P1847]	A malfunction is detected in the differential lock control unit internal circuit.	Replace differential lock control unit. Refer to DLN-314. "Removal and Installation" .

A
B
C
DLN
E
F
G
H
I
J
K
L
M
N
O
P

P1848 SOLENOID DISCONNECT

< DTC/CIRCUIT DIAGNOSIS >

[REAR FINAL DRIVE: M226 (ELD)]

P1848 SOLENOID DISCONNECT

Description

INFOID:000000007324064

When power and ground is supplied from the differential lock control unit, the differential lock solenoid will actuate to move the pressure plate against the cam ring to lock the differential. By reversing polarity at the differential lock control unit, the differential lock solenoid moves the pressure plate away from the cam ring to unlock the differential.

DTC Logic

INFOID:000000007324065

DTC	Display contents of CONSULT	DTC Detection Condition	Action to take
P1848	SOL DISCONNECT [P1848]	An open was detected in the differential lock solenoid or circuit.	Inspect differential lock solenoid. Refer to DLN-290, "Diagnosis Procedure" .

Diagnosis Procedure

INFOID:000000007324066

Regarding Wiring Diagram information, refer to [DLN-301, "Wiring Diagram"](#).

1.CHECK DIFFERENTIAL SOLENOID CONTROL

1. Start engine.
2. Using CONSULT, select "RELAY ON", "RELAY MTR", "SOL MTR" of DIFF LOCK data monitor.
3. Observe the display values while operating the differential lock system.

Monitor item	Condition	Differential lock mode switch	Display value
RELAY ON	<ul style="list-style-type: none">• Vehicle stopped• Engine running• VDC OFF switch: ON• 4WD shift switch: 4LO	ON	ON
		OFF	OFF
RELAY MTR		ON	ON
		OFF	OFF
SOL MTR		ON	ON
		OFF	OFF

Is the inspection result normal?

- YES >> Differential lock solenoid control system is operating normally.
NO >> GO TO 2.

2.CHECK DIFFERENTIAL LOCK SOLENOID RESISTANCE

1. Turn ignition switch OFF.
2. Disconnect differential lock solenoid harness connector C117.
3. Check resistance between differential lock solenoid terminals 2 and 4.

2 - 4 : Approx. 3.4Ω

Is the inspection result normal?

- YES >> GO TO 3.
NO >> Replace differential solenoid.

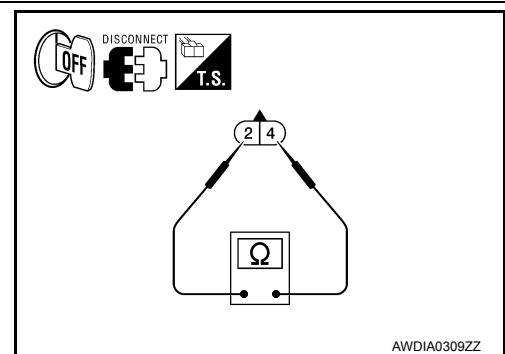

3.CHECK DIFFERENTIAL LOCK SOLENOID OPERATION

P1848 SOLENOID DISCONNECT

< DTC/CIRCUIT DIAGNOSIS >

[REAR FINAL DRIVE: M226 (ELD)]

Check operation by applying power and ground to the differential lock solenoid terminals.

Component	(+)	(-)	Solenoid operation
	Terminal	Terminal	
Differential lock solenoid	4	2	Yes

Is the inspection result normal?

YES >> GO TO 4.

NO >> Check for a mechanical malfunction with the differential lock system. Replace differential solenoid.

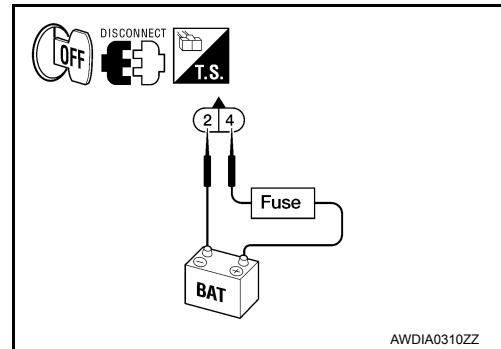

4. CHECK DIFFERENTIAL LOCK SOLENOID CIRCUIT

1. Disconnect differential lock control unit harness connector.
2. Check continuity between differential lock control unit harness connector M70 (A) terminals 11, 12 and differential lock solenoid harness connector C117 (B) terminals 4, 2.

A		B		Continuity
Connector	Terminal	Connector	Terminal	
M70	11	C117	4	Yes
	12		2	

3. Check continuity between differential lock control unit harness connector M70 (A) terminals 11, 12 and ground.

A		—	Continuity
Connector	Terminal		
M70	11	Ground	No
	12		

Is the inspection result normal?

YES >> Replace the differential lock control unit. Refer to [DLN-314, "Removal and Installation"](#).

NG >> Repair harness or connector.

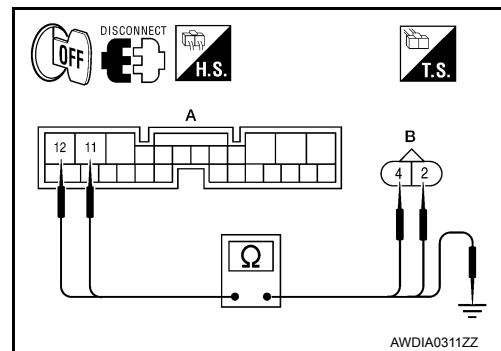

A
B
C
DLN
E
F
G
H
I
J
K
L
M
N
O
P

P1849 SOLENOID SHORT

< DTC/CIRCUIT DIAGNOSIS >

[REAR FINAL DRIVE: M226 (ELD)]

P1849 SOLENOID SHORT

Description

INFOID:000000007324067

When power and ground is supplied from the differential lock control unit, the differential lock solenoid will actuate to move the pressure plate against the cam ring to lock the differential. By reversing polarity at the differential lock control unit, the differential lock solenoid moves the pressure plate away from the cam ring to unlock the differential.

DTC Logic

INFOID:000000007324068

DTC	Display contents of CONSULT	DTC Detection Condition	Action to take
P1849	SOL SHORT [P1849]	A short was detected in the differential lock solenoid internal circuit or in the harness.	Inspect the differential lock solenoid. Refer to DLN-292 , " Diagnosis Procedure ".

Diagnosis Procedure

INFOID:000000007324069

Regarding Wiring Diagram information, refer to [DLN-301](#), "[Wiring Diagram](#)".

1.CHECK DIFFERENTIAL SOLENOID CONTROL

1. Start engine.
2. Using CONSULT, select "RELAY ON", "RELAY MTR", "SOL MTR" of DIFF LOCK data monitor.
3. Observe the display values while operating the differential lock system.

Monitor item	Condition	Differential lock mode switch	Display value
RELAY ON	<ul style="list-style-type: none">• Vehicle stopped• Engine running• VDC OFF switch: ON• 4WD shift switch: 4LO	ON	ON
		OFF	OFF
RELAY MTR		ON	ON
		OFF	OFF
SOL MTR		ON	ON
		OFF	OFF

Is the inspection result normal?

- YES >> Differential lock solenoid control system is operating normally.
NO >> GO TO 2.

2.CHECK DIFFERENTIAL LOCK SOLENOID RESISTANCE

1. Turn ignition switch OFF.
2. Disconnect differential lock solenoid harness connector C117.
3. Check resistance between differential lock solenoid terminals 2 and 4.

2 - 4 : Approx. 3.4Ω

Is the inspection result normal?

- YES >> GO TO 3.
NO >> Replace differential solenoid.

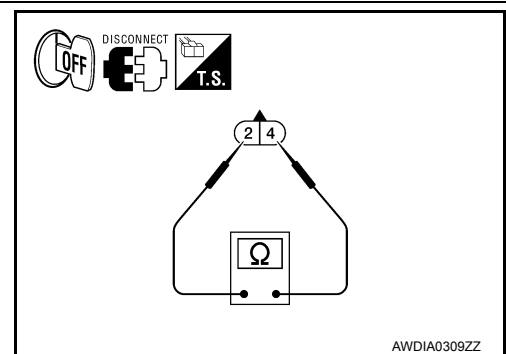

3.CHECK DIFFERENTIAL LOCK SOLENOID OPERATION

P1849 SOLENOID SHORT

< DTC/CIRCUIT DIAGNOSIS >

[REAR FINAL DRIVE: M226 (ELD)]

Check operation by applying power and ground to the differential lock solenoid terminals.

Component	(+)	(-)	Solenoid operation
	Terminal	Terminal	
Differential lock solenoid	4	2	Yes

Is the inspection result normal?

YES >> GO TO 4.

NO >> Check for a mechanical malfunction with the differential lock system. Replace differential solenoid.

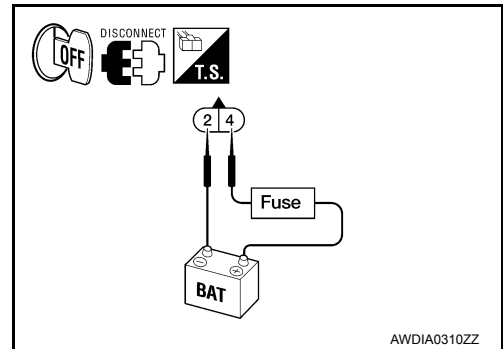

4. CHECK DIFFERENTIAL LOCK SOLENOID CIRCUIT

1. Disconnect differential lock control unit harness connector.
2. Check continuity between differential lock control unit harness connector M70 (A) terminals 11, 12 and differential lock solenoid harness connector C117 (B) terminals 4, 2.

A		B		Continuity
Connector	Terminal	Connector	Terminal	
M70	11	C117	4	Yes
	12		2	

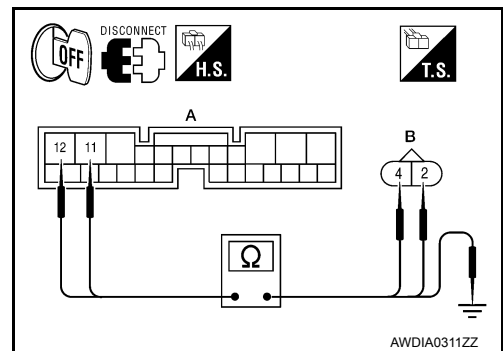

3. Check continuity between differential lock control unit harness connector M70 (A) terminals 11, 12 and ground.

A		—	Continuity
Connector	Terminal		
M70	11	Ground	No
	12		

Is the inspection result normal?

YES >> Replace the differential lock control unit. Refer to [DLN-314, "Removal and Installation"](#).

NG >> Repair harness or connector.

P1850 SOLENOID CURRENT

< DTC/CIRCUIT DIAGNOSIS >

[REAR FINAL DRIVE: M226 (ELD)]

P1850 SOLENOID CURRENT

Description

INFOID:000000007324070

The differential lock control unit supplies power and ground to the differential lock solenoid via the differential lock solenoid relay (integral to the differential lock control unit).

DTC Logic

INFOID:000000007324071

DTC	Display contents of CONSULT	DTC Detection Condition	Action to take
P1850	SOL CURRENT [P1850]	The differential lock relay does not switch to OFF or there is a short to power in the harness.	Inspect the differential lock solenoid. Refer to DLN-294 , " Diagnosis Procedure ".

Diagnosis Procedure

INFOID:000000007324072

Regarding Wiring Diagram information, refer to [DLN-301](#), "[Wiring Diagram](#)".

1. CHECK DIFFERENTIAL SOLENOID CONTROL

1. Start engine.
2. Using CONSULT, select "RELAY ON", "RELAY MTR", "SOL MTR" of DIFF LOCK data monitor.
3. Observe the display values while operating the differential lock system.

Monitor item	Condition	Differential lock mode switch	Display value
RELAY ON	<ul style="list-style-type: none"> • Vehicle stopped • Engine running • VDC OFF switch: ON • 4WD shift switch: 4LO 	ON	ON
		OFF	OFF
RELAY MTR		ON	ON
		OFF	OFF
SOL MTR		ON	ON
		OFF	OFF

Is the inspection result normal?

- YES >> Differential lock solenoid control system is operating normally.
 NO >> GO TO 2.

2. CHECK DIFFERENTIAL LOCK SOLENOID RESISTANCE

1. Turn ignition switch OFF.
2. Disconnect differential lock solenoid harness connector C117.
3. Check resistance between differential lock solenoid terminals 2 and 4.

2 - 4 : Approx. 3.4Ω

Is the inspection result normal?

- YES >> GO TO 3.
 NO >> Replace differential solenoid.

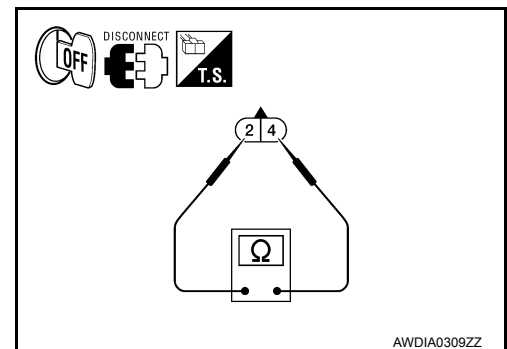

3. CHECK DIFFERENTIAL LOCK SOLENOID OPERATION

P1850 SOLENOID CURRENT

< DTC/CIRCUIT DIAGNOSIS >

[REAR FINAL DRIVE: M226 (ELD)]

Check operation by applying power and ground to the differential lock solenoid terminals.

Component	(+)	(-)	Solenoid operation
	Terminal	Terminal	
Differential lock solenoid	4	2	Yes

Is the inspection result normal?

YES >> GO TO 4.

NO >> Check for a mechanical malfunction with the differential lock system. Replace differential solenoid.

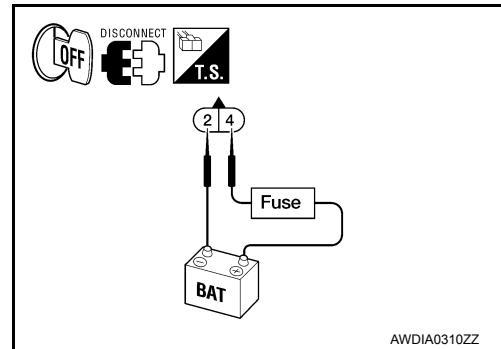

4. CHECK DIFFERENTIAL LOCK SOLENOID CIRCUIT

1. Disconnect differential lock control unit harness connector.
2. Check continuity between differential lock control unit harness connector M70 (A) terminals 11, 12 and differential lock solenoid harness connector C117 (B) terminals 4, 2.

A		B		Continuity
Connector	Terminal	Connector	Terminal	
M70	11	C117	4	Yes
	12		2	

3. Check continuity between differential lock control unit harness connector M70 (A) terminals 11, 12 and ground.

A		—	Continuity
Connector	Terminal		
M70	11	Ground	No
	12		

Is the inspection result normal?

YES >> Replace the differential lock control unit. Refer to [DLN-314, "Removal and Installation"](#).

NG >> Repair harness or connector.

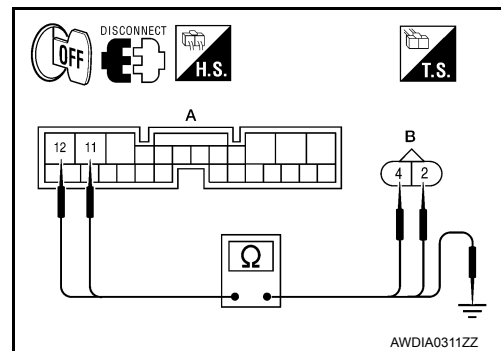

A
B
C
DLN
E
F
G
H
I
J
K
L
M
N
O
P

C1203 ABS SYSTEM

< DTC/CIRCUIT DIAGNOSIS >

[REAR FINAL DRIVE: M226 (ELD)]

C1203 ABS SYSTEM

Description

INFOID:000000007324073

The differential lock control unit and the ABS actuator and electric unit (control unit) are in communication via the CAN communication network. Vehicle speed and wheel slippage information is used by the differential lock control unit to determine if conditions are met to actuate the differential lock solenoid.

DTC Logic

INFOID:000000007324074

DTC	Display contents of CONSULT	DTC Detection Condition	Action to take
C1203	ABS SYSTEM [C1203]	A malfunction related to wheel speed sensors has been detected by the ABS actuator and electric unit (control unit).	Check for proper ABS operation. Refer to BRC-29 , " CONSULT Function (ABS) " (Type 1) or BRC-148 , " CONSULT Function (ABS) " (Type 2).

LOCK INDICATOR LAMP

< DTC/CIRCUIT DIAGNOSIS >

[REAR FINAL DRIVE: M226 (ELD)]

LOCK INDICATOR LAMP

Description

INFOID:000000007324075

The DIFF LOCK indicator lamp has power available to it any time the ignition switch is in the ON or START position. The differential lock control unit supplies ground to activate the DIFF LOCK indicator lamp. The DIFF LOCK indicator lamp will go through a prove out at initial key ON. The DIFF LOCK will flash while the differential lock system is activating or while waiting for conditions to be met to activate. Once the differential lock has been engaged, the DIFF LOCK indicator lamp will remain ON. For more information about the DIFF LOCK indicator lamp, refer to the Owner's Manual.

Component Function Check

INFOID:000000007324076

A
B
C
DLN

1. CHECK DIFF LOCK INDICATOR LAMP OPERATION

1. Turn the ignition switch ON.
2. Observe the DIFF LOCK indicator lamp.

Ignition switch ON

Indicator prove out

Does the DIFF LOCK indicator lamp prove out normally?

YES >> DIFF LOCK indicator lamp is operating normally.

NO, ALWAYS ON>> Perform self diagnostics on differential lock control unit. Refer to [DLN-276. "DIFFERENTIAL LOCK CONTROL UNIT : CONSULT Function \(DIFF LOCK\)"](#).

NO, ALWAYS OFF>>Check DIFF LOCK indicator lamp control circuit. Refer to [DLN-297. "Diagnosis Procedure"](#).

Diagnosis Procedure

INFOID:000000007324077

Regarding Wiring Diagram information, refer to [DLN-301. "Wiring Diagram"](#).

1. CHECK DIFFERENTIAL LOCK CONTROL UNIT POWER AND GROUND SUPPLY

Check the differential lock control unit power and ground supply. Refer to [DLN-279. "Diagnosis Procedure"](#).

Is the inspection result normal?

YES >> GO TO 2.

NO >> Repair or replace malfunctioning component.

2. CHECK HARNESS BETWEEN DIFFERENTIAL LOCK CONTROL UNIT AND COMBINATION METER

1. Turn ignition switch OFF.
2. Disconnect differential lock control unit harness connector and combination meter harness connector.
3. Check continuity between differential lock control unit harness connector M70 (A) terminal 21 and combination meter harness connector M24 (B) terminal 25.

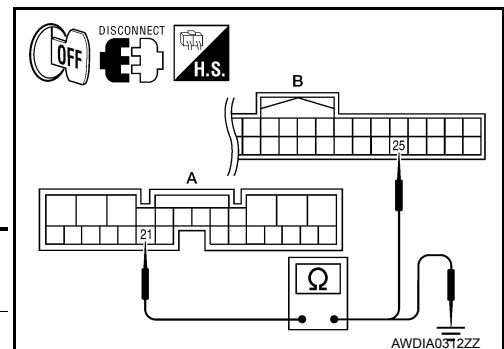

A		B		Continuity
Connector	Terminal	Connector	Terminal	
M70	21	M24	25	Yes

4. Check continuity between differential lock control unit harness connector M70 (A) terminal 21 and ground.

A		—	Continuity
Connector	Terminal		
M70	21	Ground	No

Is the inspection result normal?

E
F
G
H
I
J
K
L
M
N
O
P

LOCK INDICATOR LAMP

< DTC/CIRCUIT DIAGNOSIS >

[REAR FINAL DRIVE: M226 (ELD)]

- YES >> Replace combination meter. Refer to [MWI-89. "Removal and Installation"](#).
- NO >> Repair harness or connector.

DIFFERENTIAL LOCK CONTROL UNIT

< ECU DIAGNOSIS INFORMATION >

[REAR FINAL DRIVE: M226 (ELD)]

ECU DIAGNOSIS INFORMATION

DIFFERENTIAL LOCK CONTROL UNIT

Reference Value

INFOID:000000007324078

DIFFERENTIAL LOCK CONTROL UNIT TERMINAL CONNECTOR LAYOUT

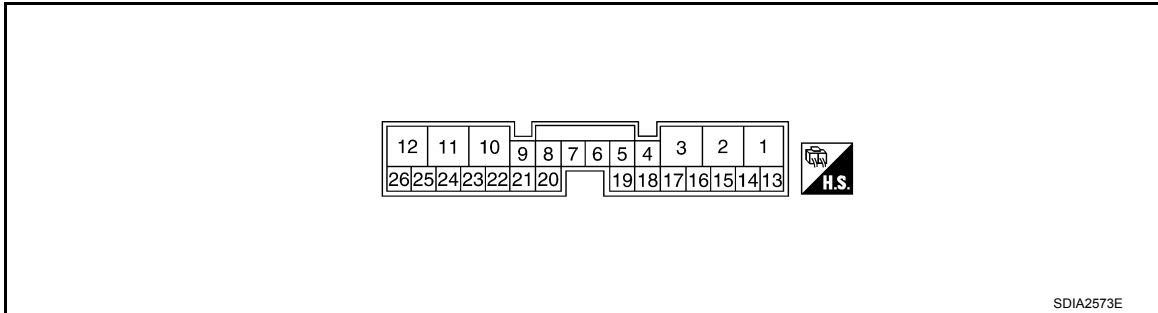

Data are reference value and are measured between each terminal and ground.

Terminal No. (Wire color)		Description		Condition	Voltage (V) (Approx.)
+	-	Signal name	Input/Output		
1 (W/G)	Ground	Ign power supply	Input	Ignition ON or START	Battery voltage
2 (W/G)	Ground	Ign power supply	Input	Ignition ON or START	Battery voltage
3 (B)	Ground	Ground	Input	Ignition ON	Less than 0.2V
4 (P)	-	CAN-L	-		-
5 (L)	-	CAN-H	-		-
9 (Y)	Ground	Differential lock mode switch (ON)	Input	Differential lock mode switch: ON	Battery voltage
				Differential lock mode switch: OFF	0V
10 (B)	Ground	Ground	Input	Ignition ON	Less than 0.2V
11 (GR)	Ground	Differential lock solenoid (LO)	Output	Differential lock mode switch: ON	0V
				Differential lock mode switch: OFF	Battery voltage
12 (L)	Ground	Differential lock solenoid (HIGH)	Output	Differential lock mode switch: ON	0V
				Differential lock mode switch: OFF	Battery voltage
13 (SB)	-	K-LINE	-		-
15 (R/Y)	Ground	Battery power supply (Memory back-up)	Input	Ignition OFF	Battery voltage
20 (BR)	Ground	Differential lock position switch	Input	Differential lock mode switch: ON (DIFF LOCK indicator lamp: ON)	0V
				Differential lock mode switch: OFF (DIFF LOCK indicator lamp: OFF)	Battery voltage
21 (SB)	Ground	DIFF LOCK indicator lamp	Output	DIFF LOCK indicator lamp: ON	0V
				DIFF LOCK indicator lamp: OFF	Battery voltage
22 (G)	Ground	Differential lock mode switch (OFF)	Input	Differential lock mode switch: ON	0V
				Differential lock mode switch: OFF	Battery voltage

CAUTION:

When using a circuit tester to measure voltage for inspection, be sure not to extend forcibly any connector terminals.

A
B
C
DLN
E
F
G
H
I
J
K
L
M
N
O
P

DIFFERENTIAL LOCK CONTROL UNIT

< ECU DIAGNOSIS INFORMATION >

[REAR FINAL DRIVE: M226 (ELD)]

DTC Index

INFOID:000000007324079

Items (CONSULT screen terms)	Diagnostic item is detected when...	Check item
INITIAL START [P1833]	Due to removal of battery which cuts off power supply to differential control unit, self-diagnosis memory function is suspended.	DLN-279. "Description"
CONTROL UNIT 1 [P1834]	Malfunction is detected in the memory (RAM) system of differential lock control unit.	DLN-280. "Description"
CONTROL UNIT 2 [P1835]	Malfunction is detected in the memory (ROM) system of differential lock control unit.	DLN-281. "Description"
CONTROL UNIT 3 [P1836]	Malfunction is detected in the memory (EEPROM) system of differential lock control unit.	DLN-282. "Description"
CONTROL UNIT 4 [P1837]	AD converter system of differential lock control unit is malfunctioning.	DLN-283. "Description"
ON SW [P1838]	More than two switch inputs are simultaneously detected due to short circuit of differential lock mode switch.	DLN-284. "Description"
POSI SW ON [P1839]	When differential lock position switch is ON, rotation difference occurs in wheel speed (rear wheel right and left).	DLN-286. "Description"
RELAY [P1844]	Differential lock control unit detects as irregular by comparing target value with monitor value.	DLN-288. "Description"
SOL CIRCUIT [P1847]	Malfunction is detected in differential lock control unit internal circuit.	DLN-289. "Description"
SOL DISCONNECT [P1848]	<ul style="list-style-type: none"> • Differential lock solenoid internal circuit or harness is open. • Differential lock solenoid relay does not switch to ON position. 	DLN-290. "Description"
SOL SHORT [P1849]	Differential lock solenoid internal circuit or harness is shorted.	DLN-292. "Description"
SOL CURRENT [P1850]	Differential lock solenoid relay does not switch to OFF position.	DLN-294. "Description"
ABS SYSTEM [C1203]	Malfunction related to wheel sensor has been detected by ABS actuator and electric unit (control unit).	DLN-296. "Description"
CAN COMM CIRCUIT [U1000]	Malfunction has been detected from CAN communication line.	DLN-278. "Description"
NO DTC IS DETECTED. FURTHER TESTING MAY BE REQUIRED.	No malfunction has been detected.	—

CAUTION:

If “CAN COMM CIRCUIT [U1000]” is displayed with other DTCs, first perform the trouble diagnosis for CAN communication line.

REAR FINAL DRIVE

< WIRING DIAGRAM >

[REAR FINAL DRIVE: M226 (ELD)]

WIRING DIAGRAM

REAR FINAL DRIVE

Wiring Diagram

INFOID:000000007324080

A
B
C
DLN
E
F
G
H
I
J
K
L
M
N
O
P

REAR FINAL DRIVE

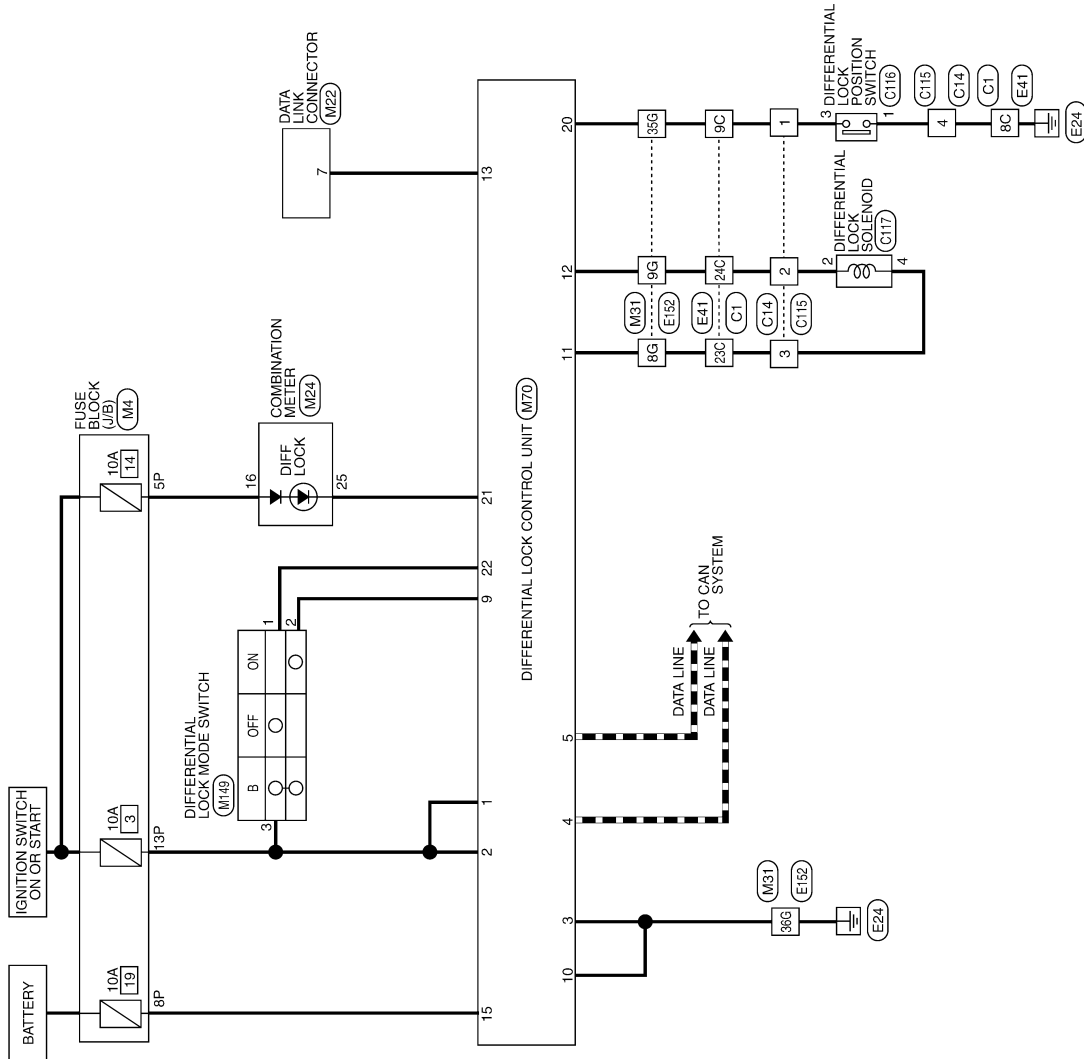

ABDWA0632GB

REAR FINAL DRIVE

< WIRING DIAGRAM >

[REAR FINAL DRIVE: M226 (ELD)]

REAR FINAL DRIVE CONNECTORS

Connector No.	M4
Connector Name	FUSE BLOCK (J/B)
Connector Color	WHITE

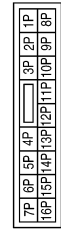

Terminal No.	Color of Wire	Signal Name
5P	W/G	-
8P	R/Y	-
13P	W/G	-

Connector No.	M22
Connector Name	DATA LINK CONNECTOR
Connector Color	WHITE

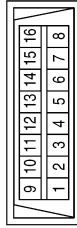

Terminal No.	Color of Wire	Signal Name
7	W	-

Connector No.	M24
Connector Name	COMBINATION METER
Connector Color	WHITE

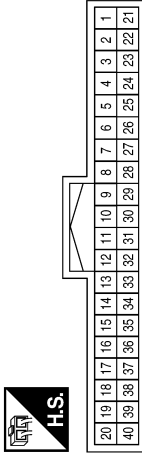

Terminal No.	Color of Wire	Signal Name
16	W/G	RUN START
25	SB	DIFF LOCK

Connector No.	M31
Connector Name	WIRE TO WIRE
Connector Color	WHITE

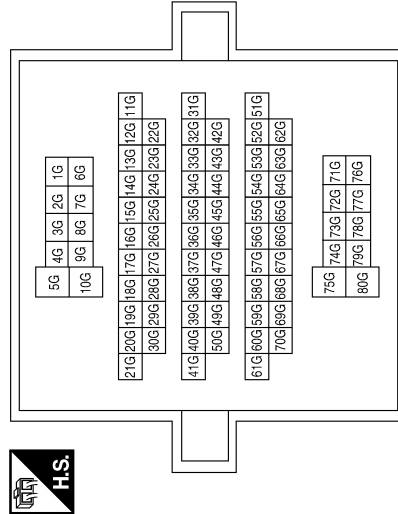

Terminal No.	Color of Wire	Signal Name
8G	GR	-
9G	L	-
35G	BR	-
36G	B	-

REAR FINAL DRIVE

< WIRING DIAGRAM >

[REAR FINAL DRIVE: M226 (ELD)]

Connector No.	M149
Connector Name	DIFFERENTIAL LOCK MODE SWITCH
Connector Color	WHITE



Terminal No.	Color of Wire	Signal Name
11	GR	DIFF LOCK LOW
12	L	DIFF LOCK HIGH
13	SB	SSS
14	-	-
15	R/Y	DIFF LOCK CU (BACK UP)
16	-	-
17	-	-
18	-	-
19	-	-
20	BR	DIFF LOCK SW
21	SB	DIFF LOCK IND
22	G	DIFF LOCK SW(OFF)
23	-	-
24	-	-
25	-	-
26	-	-

Terminal No.	Color of Wire	Signal Name
1	G	-
2	Y	-
3	W/G	-

Connector No.	M70
Connector Name	DIFFERENTIAL LOCK CONTROL UNIT
Connector Color	WHITE

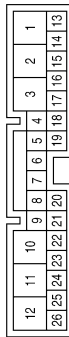

Terminal No.	Color of Wire	Signal Name
1	W/G	DIFF LOCK CU
2	W/G	DIFF LOCK CU
3	B	GND
4	P	CAN-L
5	L	CAN-H
6	-	-
7	-	-
8	-	-
9	Y	DIFF LOCK SW(ON)
10	B	GND (BACK UP)

Terminal No.	Color of Wire	Signal Name
8C	B	-
9C	BR	-
23C	GR	-
24C	L	-

Connector No.	E41
Connector Name	WIRE TO WIRE
Connector Color	BLACK

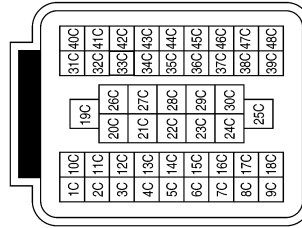

ABDIA0464GB

A
B
C
DLN
E
F
G
H
I
J
K
L
M
N
O
P

REAR FINAL DRIVE

< WIRING DIAGRAM >

[REAR FINAL DRIVE: M226 (ELD)]

Connector No.	C1
Connector Name	WIRE TO WIRE
Connector Color	BLACK

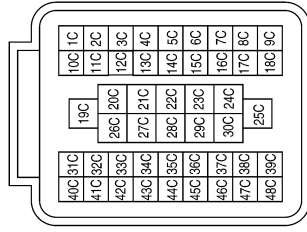

Terminal No.	Color of Wire	Signal Name
8C	B	-
9C	BR	-
23C	GR	-
24C	L	-

Terminal No.	Color of Wire	Signal Name
8G	GR	-
9G	L	-
35G	BR	-
36G	B	-

Connector No.	E152
Connector Name	WIRE TO WIRE
Connector Color	WHITE

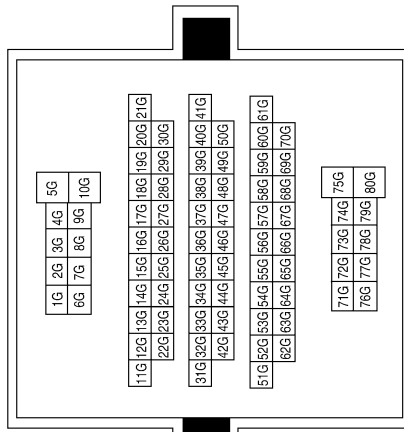

Connector No.	C116
Connector Name	DIFFERENTIAL LOCK POSITION SWITCH
Connector Color	GRAY



Terminal No.	Color of Wire	Signal Name
1	B	-
3	BR	-

Connector No.	C115
Connector Name	WIRE TO WIRE
Connector Color	GRAY



Terminal No.	Color of Wire	Signal Name
1	BR	-
2	L	-
3	GR	-
4	B	-

Connector No.	C14
Connector Name	WIRE TO WIRE
Connector Color	GRAY



Terminal No.	Color of Wire	Signal Name
1	BR	-
2	L	-
3	GR	-
4	B	-

ABDIA0869GB



REAR FINAL DRIVE

< WIRING DIAGRAM >

[REAR FINAL DRIVE: M226 (ELD)]

A
B
C
DLN
E
F
G
H
I
J
K
L
M
N
O
P

Connector No.	C117
Connector Name	DIFFERENTIAL LOCK SOLENOID
Connector Color	BLACK

Terminal No.	Color of Wire	Signal Name
2	L	-
4	GR	-

ABDIA0463GB

DIFF LOCK INDICATOR LAMP INOPERATIVE

< SYMPTOM DIAGNOSIS >

[REAR FINAL DRIVE: M226 (ELD)]

SYMPTOM DIAGNOSIS

DIFF LOCK INDICATOR LAMP INOPERATIVE

Inspection Procedure

INFOID:000000007324081

SYMPTOM:

DIFF LOCK indicator lamp does not turn ON for approx. 1 second when turning ignition switch to "ON".

DIAGNOSTIC PROCEDURE

1. PERFORM DIFFERENTIAL LOCK CONTROL UNIT SELF DIAGNOSIS

Perform self-diagnosis. Refer to [DLN-276, "DIFFERENTIAL LOCK CONTROL UNIT : CONSULT Function \(DIFF LOCK\)"](#).

Were any DTC's displayed?

- YES >> Refer to [DLN-300, "DTC Index"](#).
- NO >> GO TO 2.

2. CHECK DIFFERENTIAL LOCK CONTROL UNIT POWER SUPPLY AND GROUND CIRCUIT

Check the differential lock control unit for proper power and ground. Refer to [DLN-279, "Diagnosis Procedure"](#).

Is the inspection result normal?

- YES >> GO TO 3.
- NO >> Repair harness or connector.

3. CHECK DIFF LOCK INDICATOR LAMP POWER SUPPLY

Check power supply to the combination meter (DIFF LOCK indicator lamp). Refer to [MWI-30, "COMBINATION METER : Diagnosis Procedure"](#).

Is the inspection result normal?

- YES >> GO TO 4.
- NO >> Repair harness or connectors.

4. CHECK DIFF LOCK INDICATOR LAMP CONTROL

Check the DIFF LOCK indicator lamp control circuit. Refer to [DLN-297, "Diagnosis Procedure"](#).

Is the inspection result normal?

- YES >> Replace the differential lock control unit. Refer to [DLN-314, "Removal and Installation"](#).
- NO >> Repair malfunctioning component.

DIFF LOCK INDICATOR LAMP DOES NOT TURN ON WITH DIFFERENTIAL LOCK SWITCHED ON

< SYMPTOM DIAGNOSIS >

[REAR FINAL DRIVE: M226 (ELD)]

DIFF LOCK INDICATOR LAMP DOES NOT TURN ON WITH DIFFERENTIAL LOCK SWITCHED ON

Inspection Procedure

INFOID:000000007324082

SYMPTOM:

DIFF LOCK indicator lamp does not turn ON when turning differential lock mode switch to "ON" after engine start.

DIAGNOSTIC PROCEDURE

1. CHECK DIFF LOCK INDICATOR LAMP

Confirm the DIFF LOCK indicator lamp proves out when ignition switch is turned ON.

Is the inspection result normal?

YES >> GO TO 2.

NO >> Refer to [DLN-306, "Inspection Procedure"](#).

2. CHECK SELF-DIAGNOSTIC RESULTS

Perform self-diagnosis. Refer to [DLN-276, "DIFFERENTIAL LOCK CONTROL UNIT : CONSULT Function \(DIFF LOCK\)"](#).

Is any DTC detected by self-diagnosis?

YES >> Check the malfunctioning system. Refer to [DLN-300, "DTC Index"](#).

NO >> GO TO 3.

3. CHECK DIFFERENTIAL LOCK MODE SWITCH OPERATION

Check differential lock mode switch. Refer to [DLN-286, "Diagnosis Procedure"](#).

Is the inspection result normal?

YES >> GO TO 4.

NO >> Repair component, harness or connector.

4. CHECK DIFFERENTIAL LOCK CONTROL UNIT POWER SUPPLY AND GROUND CIRCUIT

Check differential lock control unit power supply and ground circuit. Refer to [DLN-279, "Diagnosis Procedure"](#).

Is the inspection result normal?

YES >> Replace the differential lock control unit. Refer to [DLN-314, "Removal and Installation"](#).

NO >> Repair harness or connector.

A
B
C
DLN
E
F
G
H
I
J
K
L
M
N
O
P

DIFF LOCK INDICATOR LAMP FLASHES WHILE DRIVING

< SYMPTOM DIAGNOSIS >

[REAR FINAL DRIVE: M226 (ELD)]

DIFF LOCK INDICATOR LAMP FLASHES WHILE DRIVING

Description

INFOID:000000007324083

The DIFF LOCK indicator lamp will flash once every 2 seconds when the differential lock system is in standby condition. Standby condition is the time between when the differential lock mode switch is turned ON and when the differential lock control unit sees all conditions are met to engage the differential lock. The DIFF LOCK indicator lamp should be OFF if there has been a malfunction detected. For more information regarding the differential lock system operation, refer to the Owner's Manual.

Inspection Procedure

INFOID:000000007324084

SYMPTOM:

DIFF LOCK indicator lamp sometimes flashes while driving.

DIAGNOSTIC PROCEDURE

1.CHECK SELF-DIAGNOSTIC RESULTS

Perform self-diagnosis. Refer to [DLN-276, "DIFFERENTIAL LOCK CONTROL UNIT : CONSULT Function \(DIFF LOCK\)"](#).

Is any malfunction detected by self-diagnosis?

- YES >> Check the malfunctioning system. Refer to [DLN-300, "DTC Index"](#).
- NO >> GO TO 2.

2.CHECK DIFFERENTIAL LOCK MODE SWITCH

Perform trouble diagnosis for differential lock mode switch. Refer to [DLN-284, "Diagnosis Procedure"](#).

Is the inspection result normal?

- YES >> Condition is intermittent. Refer to [GI-46, "Intermittent Incident"](#).
- NO >> Repair or replace malfunctioning component.

PRECAUTION

PRECAUTIONS

Precaution for Supplemental Restraint System (SRS) "AIR BAG" and "SEAT BELT PRE-TENSIONER"

INFOID:000000007324085

The Supplemental Restraint System such as "AIR BAG" and "SEAT BELT PRE-TENSIONER", used along with a front seat belt, helps to reduce the risk or severity of injury to the driver and front passenger for certain types of collision. This system includes seat belt switch inputs and dual stage front air bag modules. The SRS system uses the seat belt switches to determine the front air bag deployment, and may only deploy one front air bag, depending on the severity of a collision and whether the front occupants are belted or unbelted. Information necessary to service the system safely is included in the SR and SB section of this Service Manual.

WARNING:

- To avoid rendering the SRS inoperative, which could increase the risk of personal injury or death in the event of a collision which would result in air bag inflation, all maintenance must be performed by an authorized NISSAN/INFINITI dealer.
- Improper maintenance, including incorrect removal and installation of the SRS, can lead to personal injury caused by unintentional activation of the system. For removal of Spiral Cable and Air Bag Module, see the SR section.
- Do not use electrical test equipment on any circuit related to the SRS unless instructed to in this Service Manual. SRS wiring harnesses can be identified by yellow and/or orange harnesses or harness connectors.

PRECAUTIONS WHEN USING POWER TOOLS (AIR OR ELECTRIC) AND HAMMERS

WARNING:

- When working near the Airbag Diagnosis Sensor Unit or other Airbag System sensors with the Ignition ON or engine running, DO NOT use air or electric power tools or strike near the sensor(s) with a hammer. Heavy vibration could activate the sensor(s) and deploy the air bag(s), possibly causing serious injury.
- When using air or electric power tools or hammers, always switch the Ignition OFF, disconnect the battery, and wait at least 3 minutes before performing any service.

Precaution

INFOID:000000007324086

- Before connecting or disconnecting differential lock control unit harness connector, turn ignition switch "OFF" and disconnect the battery cable from the negative terminal. Because battery voltage is applied to differential lock control unit even if ignition switch is turned "OFF".

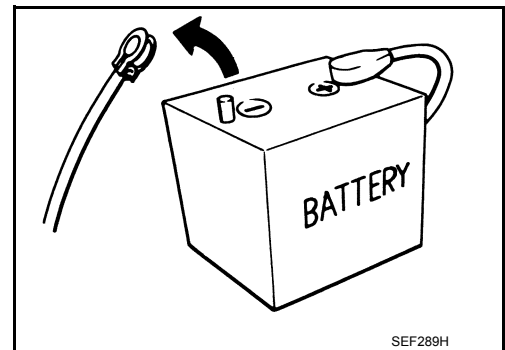

- When connecting or disconnecting pin connectors into or from differential lock control unit, take care not to damage pin terminals (bend or break). When connecting pin connectors make sure that there are not any bends or breaks on differential lock control unit pin terminal.

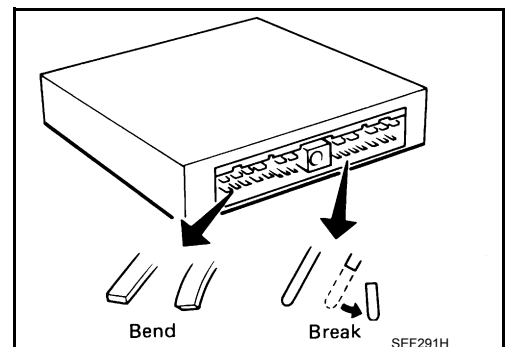

A
B
C
DLN
E
F
G
H
I
J
K
L
M
N
O
P

PRECAUTIONS

< PRECAUTION >

[REAR FINAL DRIVE: M226 (ELD)]

- Before replacing differential lock control unit, perform differential lock control unit input/output signal inspection and make sure whether differential lock control unit functions properly or not. Refer to [DLN-276. "DIFFERENTIAL LOCK CONTROL UNIT : CONSULT Function \(DIFF LOCK\)"](#).

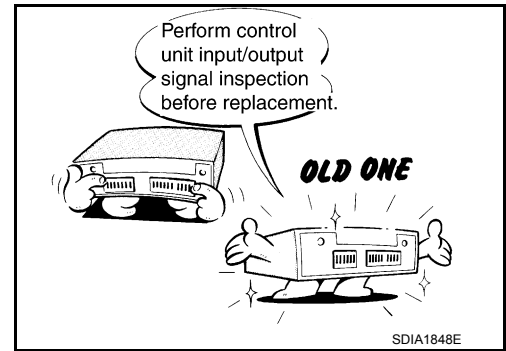

Precaution for Servicing Rear Final Drive

INFOID:000000007324087

- Before starting diagnosis of the vehicle, understand the symptoms well. Perform correct and systematic operations.
- Check for the correct installation status prior to removal or disassembly. When matching marks are required, be certain they do not interfere with the function of the parts they are applied to.
- Overhaul should be done in a clean work area, a dust proof area is recommended.
- Before disassembly, completely remove sand and mud from the exterior of the unit, preventing them from entering into the unit during disassembly or assembly.
- Always use shop paper for cleaning the inside of components.
- Avoid using cotton gloves or a shop cloth to prevent the entering of lint.
- Check appearance of the disassembled parts for damage, deformation, and abnormal wear. Replace them with new ones if necessary.
- Gaskets, seals and O-rings should be replaced any time the unit is disassembled.
- Clean and flush the parts sufficiently and blow them dry.
- Be careful not to damage sliding surfaces and mating surfaces.
- When applying sealant, remove the old sealant from the mating surface; then remove any moisture, oil, and foreign materials from the application and mating surfaces.
- In principle, tighten nuts or bolts gradually in several steps working diagonally from inside to outside. If a tightening sequence is specified, observe it.
- During assembly, observe the specified tightening torque.
- Add new differential gear oil, petroleum jelly, or multi-purpose grease, as specified.

PREPARATION

< PREPARATION >

[REAR FINAL DRIVE: M226 (ELD)]

PREPARATION

PREPARATION

Special Service Tool

INFOID:000000007324088

The actual shapes of Kent-Moore tools may differ from those of special service tools illustrated here.

Tool number (Kent-Moore No.) Tool name	Description
ST33290001 (J-34286) Puller	Removing front oil seal
ST15310000 (—) Drift	Installing front oil seal a: 96 mm (3.77 in) dia. b: 84 mm (3.30 in) dia.
ST3127S000 (J-25765-A) Preload gauge set <ol style="list-style-type: none"> 1. GG91030000 (J-25765) Torque wrench 2. HT62940000 (1/2") (—) Socket adapter 3. HT62900000 (3/8") (—) Socket adapter 	Inspecting drive pinion bearing preload torque and total preload torque
— (C-4164) Adjuster tool	Removing and installing side bearing adjuster
KV10111100 (J-37228) Seal cutter	Removing carrier cover

A
B
C
DLN
E
F
G
H
I
J
K
L
M
N
O
P



PREPARATION

< PREPARATION >

[REAR FINAL DRIVE: M226 (ELD)]

Commercial Service Tool

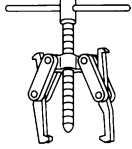
INFOID:000000007324089

Tool name	Description
Puller  NT077	Removing companion flange and side bearing inner race
Power tool  PIIB1407E	Loosening nuts, screws and bolts

PERIODIC MAINTENANCE

DIFFERENTIAL GEAR OIL

Changing Differential Gear Oil

INFOID:000000007324090

DRAINING

1. Stop engine.
2. Remove the drain plug from the rear final drive assembly to drain the differential gear oil.
3. Install the drain plug with sealant applied on the threads to the rear final drive assembly. Tighten to the specified torque. Refer to [DLN-324, "Disassembly and Assembly"](#).
 - Use High Performance Thread Sealant or equivalent. Refer to [GI-22, "Recommended Chemical Products and Sealants"](#)

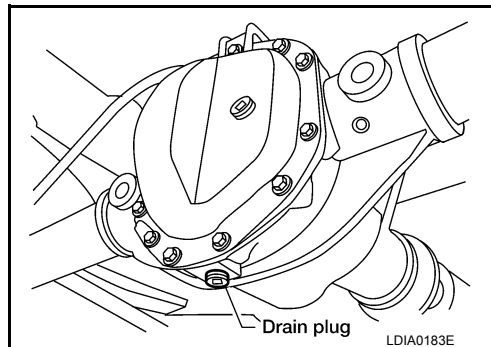

FILLING

1. Remove the filler plug from the rear final drive assembly.
2. Fill the rear final drive assembly with new differential gear oil until the level reaches the specified level near the filler plug hole.

Differential gear oil grade and capacity : Refer to [MA-18, "FOR USA AND CANADA : Fluids and Lubricants"](#) (United States and Canada) or [MA-20, "FOR MEXICO : Fluids and Lubricants"](#) (Mexico).

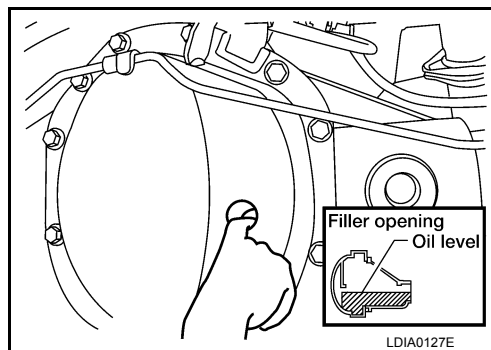

3. Install the filler plug with sealant applied on the threads to the rear final drive assembly. Tighten to the specified torque. Refer to [DLN-324, "Disassembly and Assembly"](#).
 - Use High Performance Thread Sealant or equivalent. Refer to [GI-22, "Recommended Chemical Products and Sealants"](#).

Checking Differential Gear Oil

INFOID:000000007324091

DIFFERENTIAL GEAR OIL LEAKAGE AND LEVEL

1. Make sure that differential gear oil is not leaking from the rear final drive assembly or around it.
2. Check the differential gear oil level from the filler plug hole as shown.

CAUTION:

Do not start engine while checking differential gear oil level.

3. Install the filler plug with sealant applied on the threads to the rear final drive assembly. Tighten to the specified torque. Refer to [DLN-324, "Disassembly and Assembly"](#).
 - Use High Performance Thread Sealant or equivalent. Refer to [GI-22, "Recommended Chemical Products and Sealants"](#).

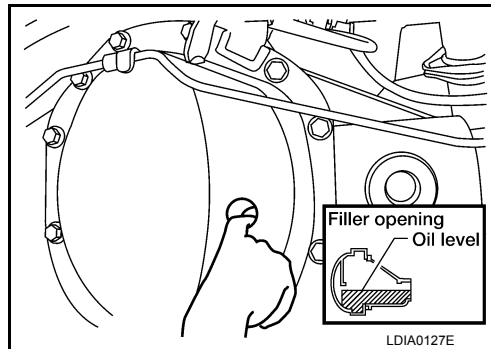

A
B
C
DLN
E
F
G
H
I
J
K
L
M
N
O
P

DIFFERENTIAL LOCK CONTROL UNIT

< REMOVAL AND INSTALLATION >

[REAR FINAL DRIVE: M226 (ELD)]

REMOVAL AND INSTALLATION

DIFFERENTIAL LOCK CONTROL UNIT

Removal and Installation

INFOID:000000007324092

REMOVAL

1. Disconnect the battery negative terminal. Refer to [PG-80. "Removal and Installation"](#).
2. Remove the instrument lower panel LH. Refer to [IP-18. "Removal and Installation"](#).
3. Disconnect the harness connector from differential lock control unit (1).

↔ : Front

2 : Steering column

4. Remove the two nuts and remove differential lock control unit.

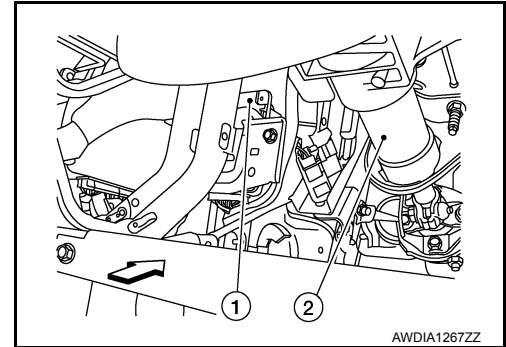

INSTALLATION

Note the following, and installation is in the reverse order of removal.

- When installing differential lock control unit, tighten nuts to the specified torque.

Differential lock control unit nuts : 5.1 N·m (0.52 kg-m, 45 in-lb)

DIFFERENTIAL LOCK POSITION SWITCH

< REMOVAL AND INSTALLATION >

[REAR FINAL DRIVE: M226 (ELD)]

DIFFERENTIAL LOCK POSITION SWITCH

Removal and Installation

INFOID:000000007324093

REMOVAL

Differential Lock Position Switch

CAUTION:

- Be careful not to damage spline, companion flange and front oil seal when removing propeller shaft.
- Before removing rear final drive assembly or rear axle assembly, disconnect ABS sensor harness connector from the assembly and move it away from rear final drive assembly/rear axle assembly area. Failure to do so may result in sensor wires being damaged and sensor becoming inoperative.

1. Drain rear final drive gear oil. Refer to [DLN-313, "Changing Differential Gear Oil"](#).
2. Remove rear propeller shaft. Refer to [DLN-146, "Removal and Installation"](#).
3. Remove both RH and LH axle shafts. Refer to [RAX-19, "Removal and Installation"](#).
4. Remove the carrier cover. Refer to [DLN-321, "Removal and Installation"](#).
5. Remove differential lock solenoid connector (B) bolt and disconnect differential lock position connector (A).

- ←: Front

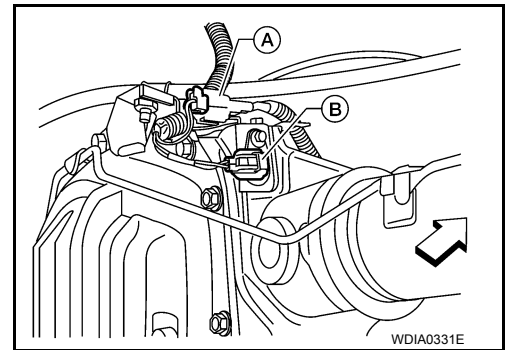

6. For installation, apply a paint matching mark on one side of side bearing cap.

CAUTION:

- Side bearing caps are line-board for initial assembly. The matching marks are used to install them in their original positions.
- For matching mark, use paint. Do not damage side bearing cap.

7. Remove adjuster lock plates.

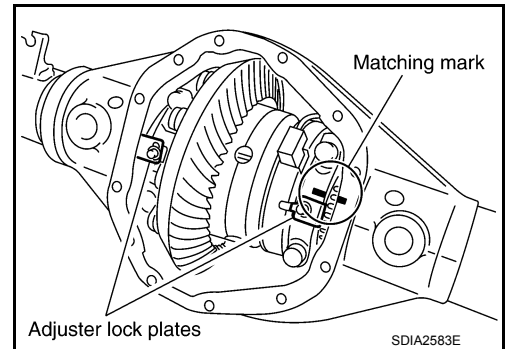

8. Remove side bearing caps.

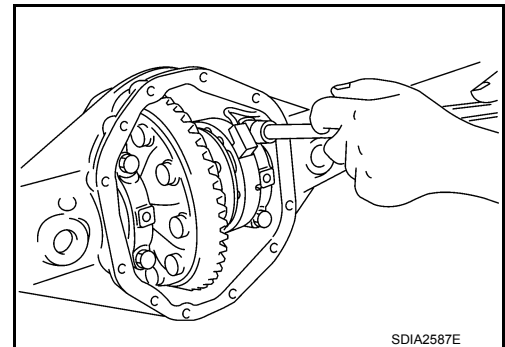

A
B
C
DLN
E
F
G
H
I
J
K
L
M
N
O
P

DIFFERENTIAL LOCK POSITION SWITCH

< REMOVAL AND INSTALLATION >

[REAR FINAL DRIVE: M226 (ELD)]

9. Loosen the side bearing adjusters using Tool.

Tool number : — (C - 4164)

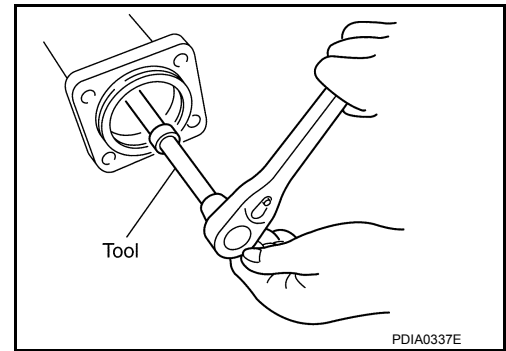

10. Remove the differential case assembly, keep side bearing outer races together with inner races. Do not mix them up. Also, keep side bearing adjusters together with bearing.

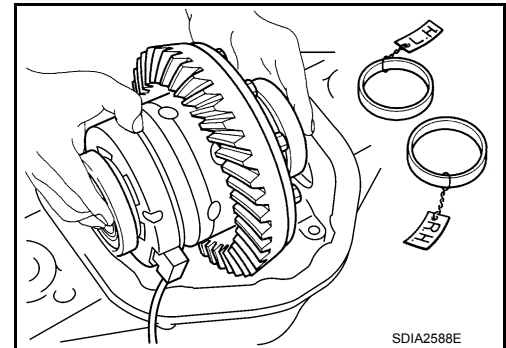

11. Remove side bearing adjusters from gear carrier.

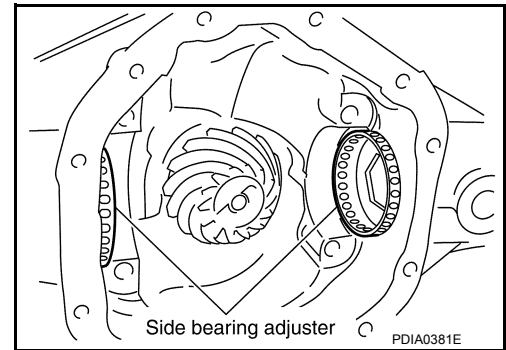

12. Remove bracket for the differential lock position switch connector and bolts.
13. Remove differential lock position switch.

INSTALLATION

1. Apply sealant to threads of differential lock position switch.
• Use Genuine Silicone RTV or equivalent. Refer to [GI-22. "Recommended Chemical Products and Sealants"](#).

CAUTION:

Remove old sealant adhering to gear carrier and differential lock position switch. Also remove any moisture, oil, or foreign material adhering to application and gear carrier and differential lock position switch.

2. Install differential lock position switch on gear carrier and tighten differential lock position switch bolts with the specified torque. Refer to [DLN-324. "Disassembly and Assembly"](#).

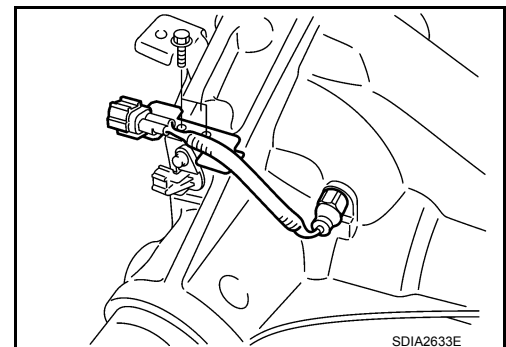

DIFFERENTIAL LOCK POSITION SWITCH

< REMOVAL AND INSTALLATION >

[REAR FINAL DRIVE: M226 (ELD)]

3. Install side bearing adjusters into gear carrier.

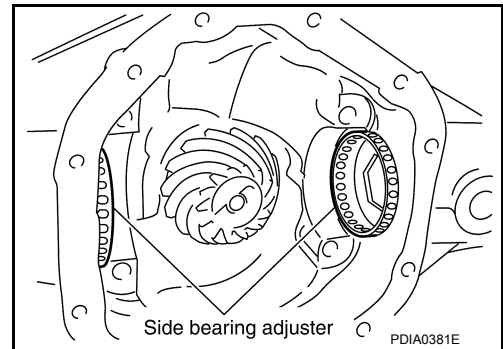

4. Apply gear oil to side bearings. Install differential case assembly with side bearing outer races into gear carrier.
5. Apply multi-purpose grease to differential lock position connector.

CAUTION:

Do not reuse sensor connector.

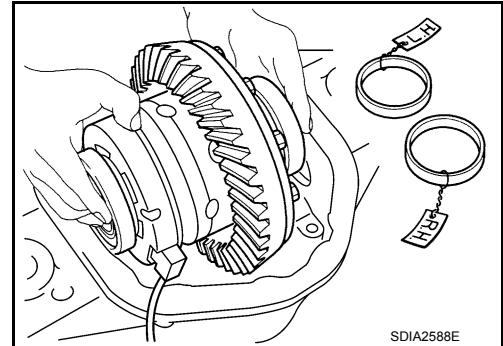

6. Connect differential lock solenoid harness (B) and differential lock position switch connector (A). Then install it to gear carrier, tighten to the specified torque. Refer to [DLN-324, "Disassembly and Assembly"](#).

- ←: Front

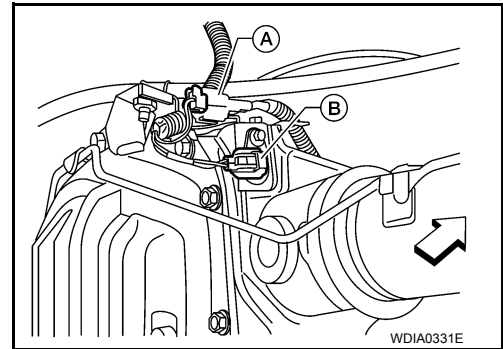

7. Align paint matching mark on side bearing caps with that on gear carrier and install side bearing caps on gear carrier without tightening to specification.

CAUTION:

Do not tighten at this point. This allows further tightening of side bearing adjusters.

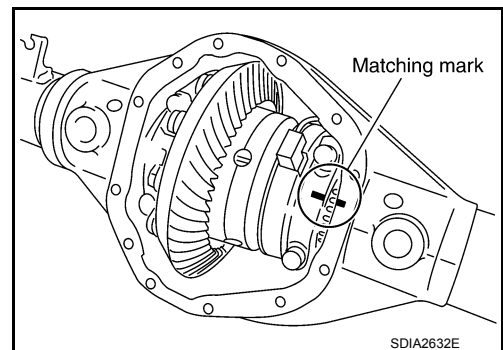

8. Tighten each side bearing adjusters using adjuster tool.

Tool number : — (C - 4164)

9. Adjusting backlash of drive gear and drive pinion. Refer to [DLN-324, "Disassembly and Assembly"](#).
10. Check total preload torque. Refer to [DLN-324, "Disassembly and Assembly"](#).
11. Check tooth contact. Refer to [DLN-324, "Disassembly and Assembly"](#).

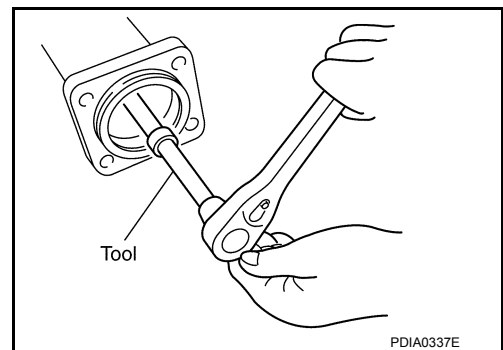

A
B
C
DLN
E
F
G
H
I
J
K
L
M
N
O
P

DIFFERENTIAL LOCK POSITION SWITCH

< REMOVAL AND INSTALLATION >

[REAR FINAL DRIVE: M226 (ELD)]

12. Apply a bead of sealant to the mating surface of the carrier cover as shown.

- Use Genuine Silicone RTV or equivalent. Refer to [GI-22, "Recommended Chemical Products and Sealants"](#).

CAUTION:

Remove any old sealant adhering to the mating surfaces. Also remove any moisture, oil, or foreign material adhering to the application and mating surfaces.

13. Install the carrier cover to the gear carrier. Tighten the bolts to the specified torque. Refer to [DLN-321, "Removal and Installation"](#).

14. Installation of the remaining components is in the reverse order of removal.

CAUTION:

Fill the front final drive assembly with recommended differential gear oil. Refer to [DLN-313, "Changing Differential Gear Oil"](#).

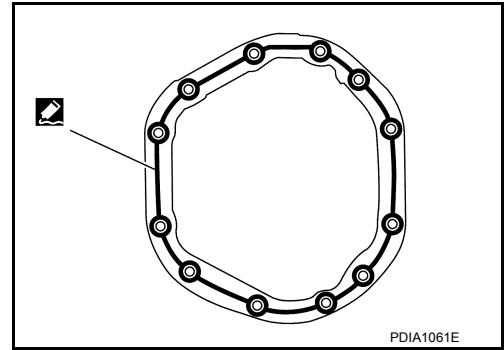

FRONT OIL SEAL

< REMOVAL AND INSTALLATION >

[REAR FINAL DRIVE: M226 (ELD)]

FRONT OIL SEAL

Removal and Installation

INFOID:000000007324094

REMOVAL

1. Remove rear propeller shaft. Refer to [DLN-146, "Removal and Installation"](#).
2. Remove brake calipers and rotors. Refer to [BR-40, "Removal and Installation of Brake Caliper and Disc Rotor"](#).
3. Measure the total preload torque. Refer to [DLN-334, "Inspection and Adjustment"](#).

NOTE:

Record the total preload torque measurement.

4. Remove the drive pinion nut using suitable tool.

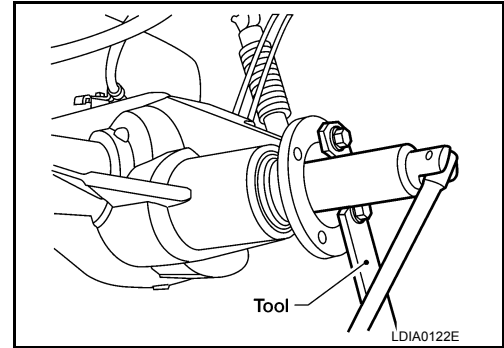

5. Put matching marks on the companion flange and drive pinion using paint.

CAUTION:

Use paint to make the matching marks. Do not damage the companion flange or drive pinion.

6. Remove the companion flange using suitable tool.

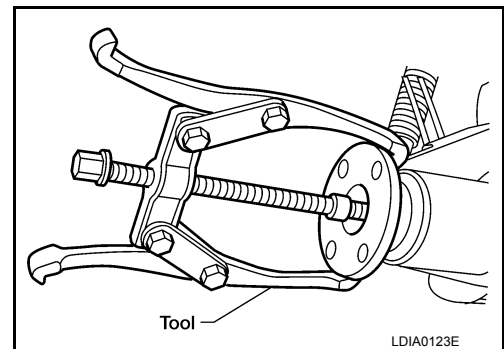

7. Remove oil seal/dust shield and discard.

CAUTION:

Do not reuse oil seal/dust shield.

8. Remove the front oil seal using Tool.

Tool number : ST33290001 (J-34286)

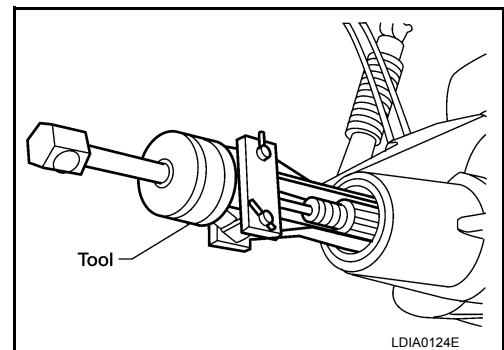

INSTALLATION

A
B
C
DLN
E
F
G
H
I
J
K
L
M
N
O
P

FRONT OIL SEAL

< REMOVAL AND INSTALLATION >

[REAR FINAL DRIVE: M226 (ELD)]

1. Apply multi-purpose grease to the lips of the new front oil seal. Then drive the new front oil seal in evenly until it becomes flush with the gear carrier using Tool.

Tool number : ST15310000 (—)

CAUTION:

- Do not reuse front oil seal.
- Do not incline the new front oil seal when installing.
- Apply multi-purpose grease to the lips and differential gear oil to the circumference of the new front oil seal.

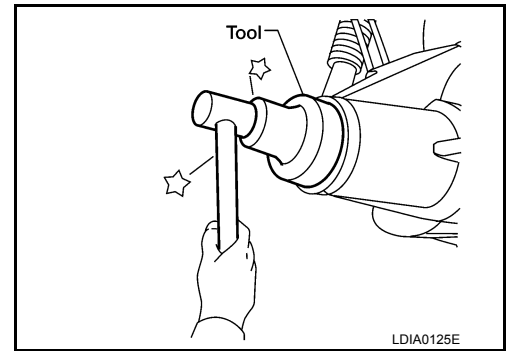

2. Install a new oil seal/dust shield.

CAUTION:

Do not reuse oil seal/dust shield.

3. Install the companion flange to the drive pinion while aligning the matching marks.
4. Apply anti-corrosive oil to the threads of the drive pinion and the seating surface of the new drive pinion lock nut and new drive pinion lock nut washer. Then adjust the drive pinion lock nut tightening torque using suitable tool (A), and check the total preload torque using Tool (B).

Tool number (B): ST3127S000 (J-25765-A)

Total preload torque: Refer to [DLN-334, "Inspection and Adjustment"](#).

- The total preload torque should be within the total preload torque specification. When not replacing the collapsible spacer, it should also be equal to the measurement taken during removal plus an additional 0.56 N·m (0.06 Kg-m, 5 in-lb).
- If the total preload torque is low, tighten the drive pinion lock nut in 6.8 N·m (0.69 Kg-m, 5ft-lb) increments until the total preload torque is met.

CAUTION:

- Do not reuse drive pinion lock nut or drive pinion lock nut washer.
- Apply anti-corrosive oil to the threads of the drive pinion and the seating surface of the new drive pinion lock nut.
- Adjust the drive pinion lock nut tightening torque to the lower limit first. Do not exceed the drive pinion lock nut specified torque. Refer to [DLN-324, "Disassembly and Assembly"](#).
- Do not loosen drive pinion lock nut to adjust the total preload torque. If the total preload torque exceeds the specifications, replace the collapsible spacer and tighten it again to adjust. Refer to [DLN-324, "Disassembly and Assembly"](#).
- After adjustment, rotate drive pinion back and forth 2 to 3 times to check for unusual noise, rotation malfunction, and other malfunctions.

5. Installation of the remaining components is in the reverse order of removal.

CAUTION:

Check the differential gear oil level and refill as necessary. Refer to [DLN-313, "Checking Differential Gear Oil"](#).

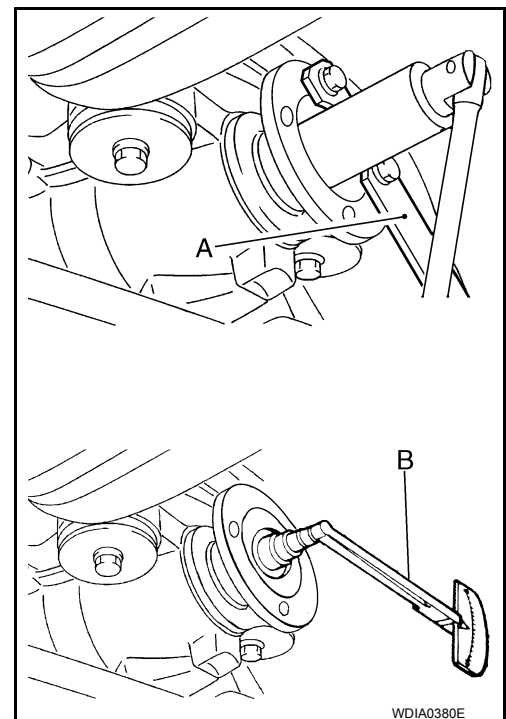

CARRIER COVER

< REMOVAL AND INSTALLATION >

[REAR FINAL DRIVE: M226 (ELD)]

CARRIER COVER

Removal and Installation

INFOID:000000007324095

REMOVAL

1. Drain the differential gear oil. Refer to [DLN-313](#).
2. Disconnect the parking brake cable (A) and brake tube (B) from the carrier cover.
3. Remove the carrier cover bolts and separate the carrier cover from the gear carrier using Tool.

Tool number : KV10111100 (J-37228)

CAUTION:

- Do not damage the mating surface.
- Do not insert flat-bladed screwdriver, this will damage the mating surface.

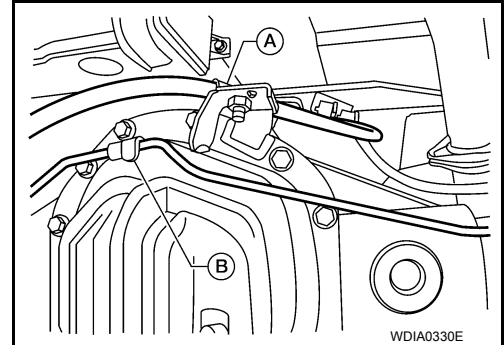

INSTALLATION

1. Apply a bead of sealant to the mating surface of the carrier cover as shown.
 - Use Genuine Silicone RTV or equivalent. Refer to [GI-22](#), "[Recommended Chemical Products and Sealants](#)".
2. Install the carrier cover to the gear carrier. Tighten the bolts to the specified torque. Refer to [DLN-324](#), "[Disassembly and Assembly](#)".
3. Connect the parking brake cable and brake tube to the carrier cover.
4. Fill the rear final drive assembly with recommended differential gear oil. Refer to [DLN-313](#), "[Changing Differential Gear Oil](#)".

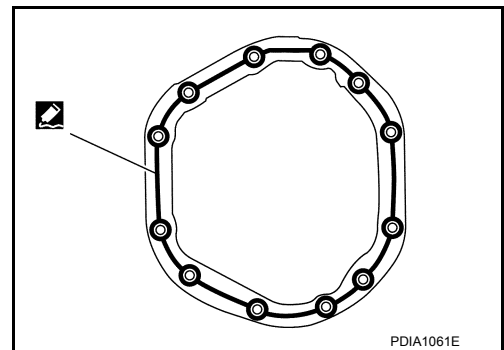

REAR FINAL DRIVE ASSEMBLY

< UNIT REMOVAL AND INSTALLATION >

[REAR FINAL DRIVE: M226 (ELD)]

UNIT REMOVAL AND INSTALLATION

REAR FINAL DRIVE ASSEMBLY

Removal and Installation

INFOID:000000007324096

REMOVAL

CAUTION:

- Do not damage spline, companion flange and front oil seal when removing propeller shaft.
- Before removing final drive assembly or rear axle assembly, disconnect ABS sensor harness connector from the assembly and move it away from final drive/rear axle assembly area. Failure to do so may result in sensor wires being damaged and sensor becoming inoperative.

1. Remove the rear brake disc rotors. Refer to [BR-40, "Removal and Installation of Brake Caliper and Disc Rotor"](#).
2. Remove the rear propeller shaft. Refer to [DLN-146, "Removal and Installation"](#).
3. Disconnect the following components from the rear final drive assembly.
 - Brake tube block connectors. Refer to [BR-40, "Removal and Installation of Brake Caliper and Disc Rotor"](#).
 - Wheel sensor wire harness. Refer to [BRC-114, "Removal and Installation"](#) (Type 1) or [BRC-237, "Removal and Installation"](#) (Type 2).
 - Parking brake cable (A).
 - Brake tube (B).

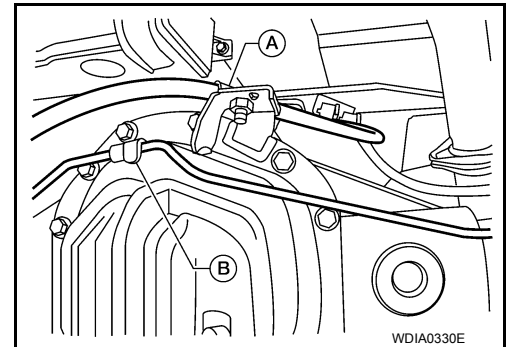

- Differential lock position switch harness connector (A).
- Differential lock solenoid harness connector (B).
- ⇐: Front

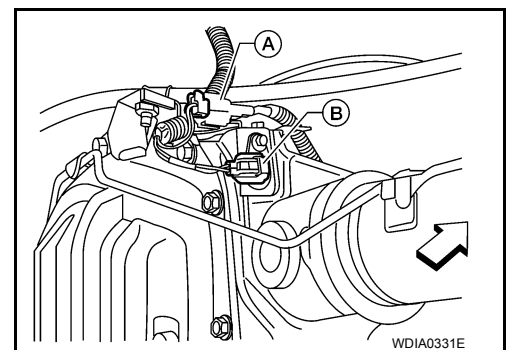

4. Disconnect brake hose from brake tube at the mounting clip on top of rear final drive assembly. Then remove the metal clip to disconnect brake line from the mounting clip on top of the rear final drive assembly.
5. Support rear final drive using a suitable jack.
6. Remove rear shock absorber lower bolts. Refer to [RSU-8, "Removal and Installation"](#).
7. Remove leaf spring U-bolt nuts. Refer to [RSU-9, "Removal and Installation"](#).
8. Remove rear final drive assembly.

CAUTION:

Secure rear final drive assembly to the jack while removing it.

INSTALLATION

Installation is in the reverse order of removal.

CAUTION:

REAR FINAL DRIVE ASSEMBLY

< UNIT REMOVAL AND INSTALLATION >

[REAR FINAL DRIVE: M226 (ELD)]

Check the front final drive assembly differential gear oil and refill as necessary. Check for fluid leaks. Refer to [DLN-313, "Changing Differential Gear Oil"](#).

- A
- B
- C
- DLN**
- E
- F
- G
- H
- I
- J
- K
- L
- M
- N
- O
- P

REAR FINAL DRIVE

< UNIT DISASSEMBLY AND ASSEMBLY >

[REAR FINAL DRIVE: M226 (ELD)]

INSPECTION AND ADJUSTMENT

- Drain the differential gear oil before inspection and adjustment. Refer to [DLN-313. "Changing Differential Gear Oil"](#).
- Remove and install the carrier cover as necessary for inspection and adjustment. Refer to [DLN-321. "Removal and Installation"](#).

Total Preload Torque

1. Rotate the drive pinion back and forth 2 to 3 times to check for unusual noise and rotation malfunction.
2. Rotate the drive pinion at least 20 times to check for smooth operation of the bearings.
3. Measure total preload torque using Tool. Refer to [DLN-334. "Inspection and Adjustment"](#).
 - If the measured value is out of the specification, check and adjust each part. Adjust the drive pinion bearing preload torque first, then adjust the side bearing preload torque.

Tool number : ST3127S000 (J-25765-A)

NOTE:

Total preload torque = Drive pinion bearing preload torque + Side bearing preload torque

If the total preload torque is greater than specification

On drive pinion bearings : Replace collapsible spacer.

On side bearings : Loosen side bearing adjuster.

If the total preload torque is less than specification

On drive pinion bearings : Tighten drive pinion lock nut.

On side bearings : Tighten side bearing adjuster.

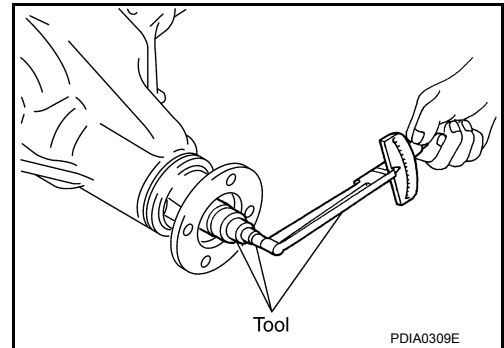

Tooth Contact

Checking gear tooth contact pattern is necessary to verify correct relationship between drive gear and drive pinion. Gears which are not positioned in proper arrangement may be noisy and/or have a short life. Check gear tooth contact pattern to obtain the best contact for low noise and long life.

1. Thoroughly clean drive gear and drive pinion teeth.
2. Apply red lead to the drive gear.
 - Apply red lead to both faces of three to four gears, at four locations evenly spaced on the drive gear.

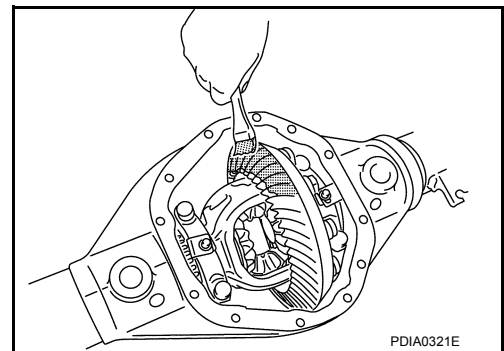

3. Hold companion flange steady by hand and rotate drive gear in both directions.

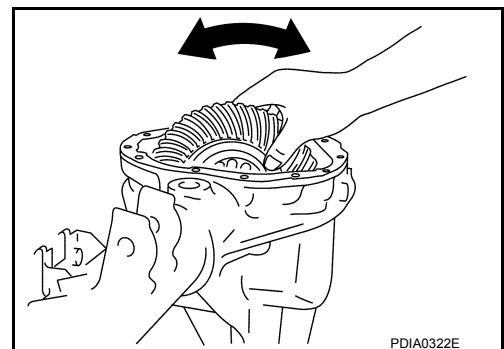

REAR FINAL DRIVE

< UNIT DISASSEMBLY AND ASSEMBLY >

[REAR FINAL DRIVE: M226 (ELD)]

Usually the pattern will be correct if washers are correctly calculated and the backlash is correct. However, in rare cases, trial and error processes may be employed to obtain a correct pattern. The tooth pattern is the best indication of how well a differential has been set up.

Heel contact

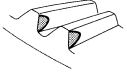

Face contact

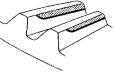

Toe contact

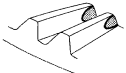

Flank contact

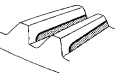

To correct, increase thickness of drive pinion height adjusting washer in order to bring drive pinion close to drive gear.

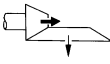

To correct, reduce thickness of drive pinion height adjusting washer in order to make drive pinion go away from drive gear.

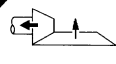

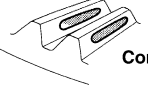

Correct tooth contact

When adjustment is completed, be sure to wipe off completely the red lead and oil or their equivalent.

SDIA2591E

4. If outside the standard, replace the rear final drive assembly. Refer to [DLN-322. "Removal and Installation"](#).

Backlash

1. Fit a dial indicator to the drive gear face to measure the backlash.

Backlash : 0.12 - 0.20 mm (0.0050 - 0.0078 in)

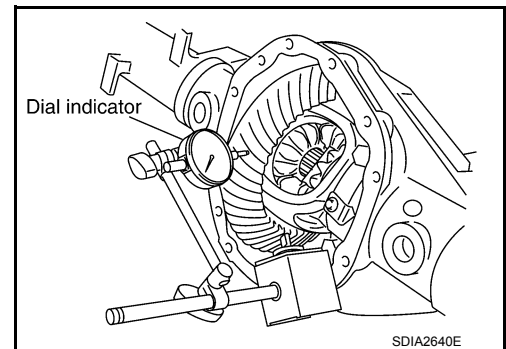

2. If the backlash is outside of the specification, adjust each side bearing adjuster.

- a. Remove adjuster lock plates.
- b. Loosen side bearing cap bolts.

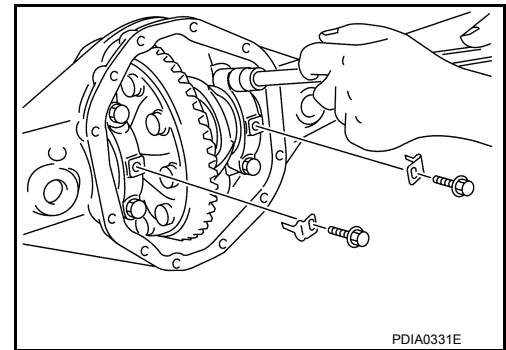

- c. Tighten or loosen each side bearing adjuster using Tool.

Tool number : — (C - 4164)

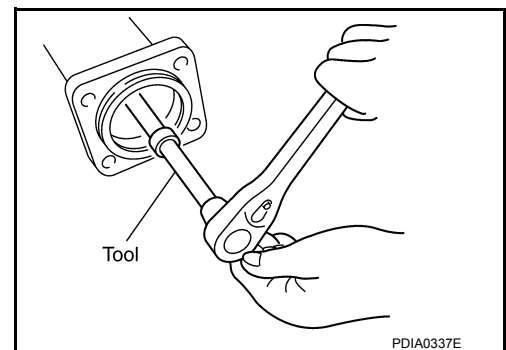

REAR FINAL DRIVE

< UNIT DISASSEMBLY AND ASSEMBLY >

[REAR FINAL DRIVE: M226 (ELD)]

If the backlash is greater than specification:

Loosen side bearing adjuster (A) and tighten side bearing adjuster (B) by the same amount.

If the backlash is less than specification:

Loosen side bearing adjuster (B) and tighten side bearing adjuster (A) by the same amount.

CAUTION:

Do not change the side bearing side bearing adjusters by different amounts as it will change the side bearing preload torque.

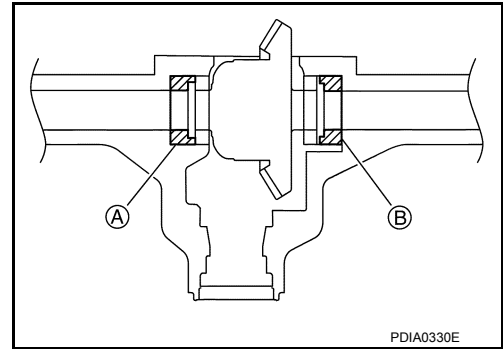

A

B

C

DLN

- d. Tighten side bearing cap bolts to the specified torque.
- e. Install adjuster lock plate and tighten to the specified torque.

CAUTION:

Check tooth contact and total preload torque after adjusting side bearing adjuster. Refer to [DLN-334, "Inspection and Adjustment"](#).

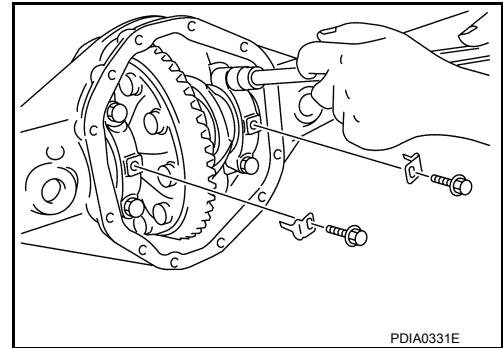

E

F

G

H

Companion Flange Runout

- 1. Rotate companion flange and check for runout on the companion flange face (inner side of the bolt holes) and companion flange inner side (socket diameter) using suitable tool. Refer to [DLN-334, "Inspection and Adjustment"](#).
- 2. If the runout is outside the runout limit, follow the procedure below to adjust.
 - a. Rotate the companion flange on the drive pinion by 90°, 180° and 270° while checking for the position where the runout is minimum.
 - b. If the runout is still outside of the runout limit after the companion flange has been rotated on the drive pinion, possible cause could be an assembly malfunction of drive pinion and drive pinion bearing or a malfunctioning drive pinion bearing.
 - c. If the runout is still outside of the runout limit after replacing the companion flange. Replace the rear final drive assembly. Refer to [DLN-322, "Removal and Installation"](#).

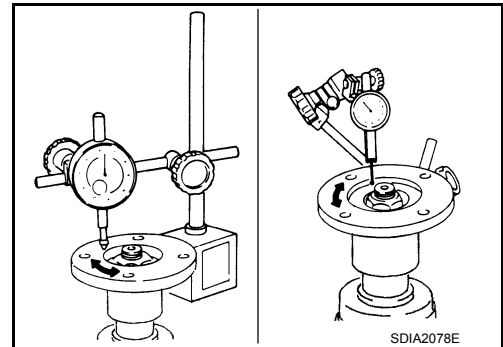

I

J

K

L

DISASSEMBLY

Differential Assembly

- 1. Remove carrier cover bolts.
- 2. Remove carrier cover using Tool.

Tool number : KV10111100 (J-37228)

CAUTION:

- Do not damage the mating surface.
- Do not insert flat-bladed screwdriver, this will damage the mating surface.

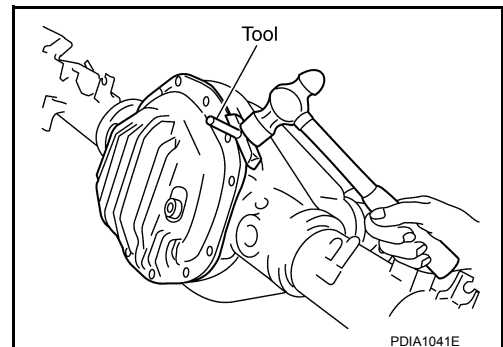

N

O

P

REAR FINAL DRIVE

< UNIT DISASSEMBLY AND ASSEMBLY >

[REAR FINAL DRIVE: M226 (ELD)]

3. Remove sensor connector bolts and disconnect differential lock solenoid connector.

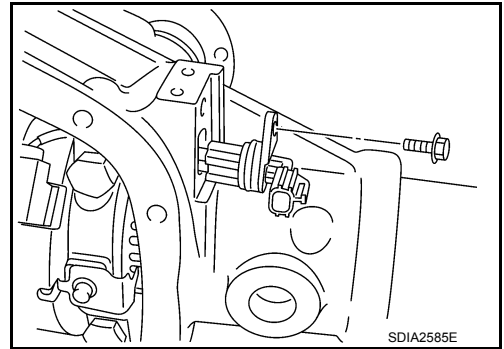

4. For proper reinstallation, paint matching mark on one side of side bearing cap.

CAUTION:

- Side bearing caps are line-board for initial assembly. The matching marks are used to reinstall them in their original positions.
- For matching mark, use paint. Do not damage side bearing cap.

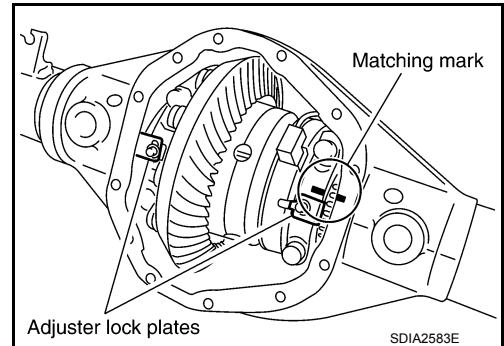

5. Remove adjuster lock plates.
6. Remove side bearing caps.

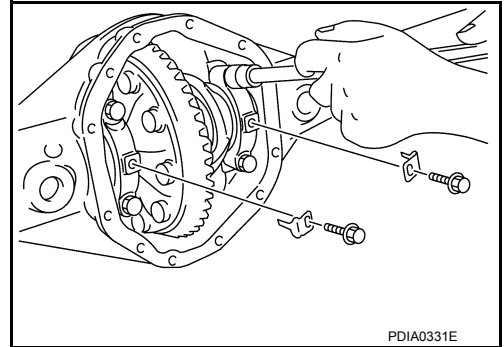

7. Loosen side bearing adjusters using Tool.

Tool number : — (C - 4164)

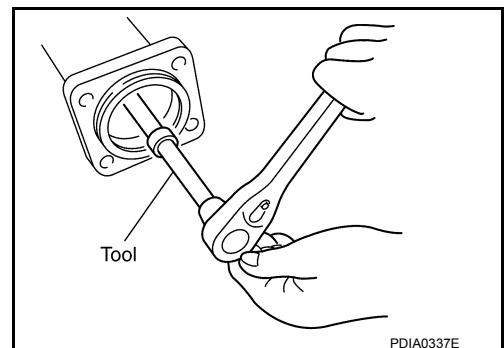

8. Remove differential lock position switch.
9. Remove differential lock position switch bracket.

REAR FINAL DRIVE

< UNIT DISASSEMBLY AND ASSEMBLY >

[REAR FINAL DRIVE: M226 (ELD)]

10. Remove the differential case assembly. Label side bearing outer races to keep them together with inner races. Do not mix them up.

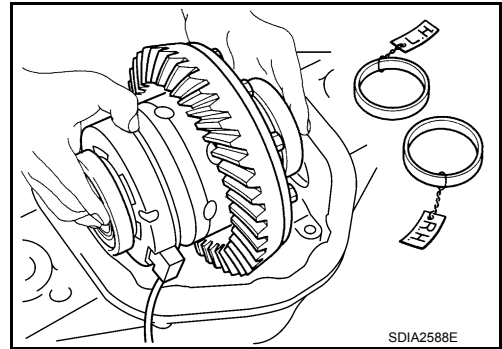

A
B
C

DLN

Drive Pinion Assembly

1. Put matching marks on the companion flange at location (A) and drive pinion using paint as shown.

CAUTION:

Use paint to make the matching marks. Do not damage the companion flange or drive pinion.

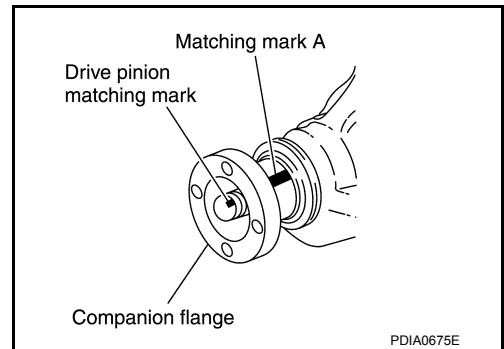

E
F
G

2. Remove drive pinion lock nut and washer using suitable tool.

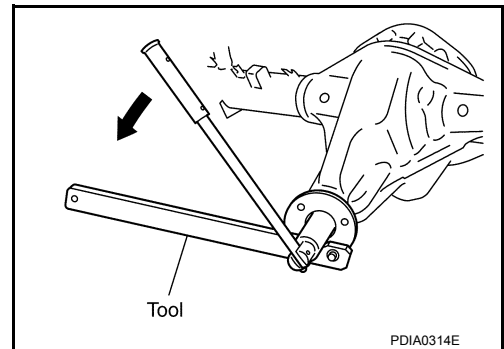

H
I
J
K

3. Remove companion flange using a suitable tool.

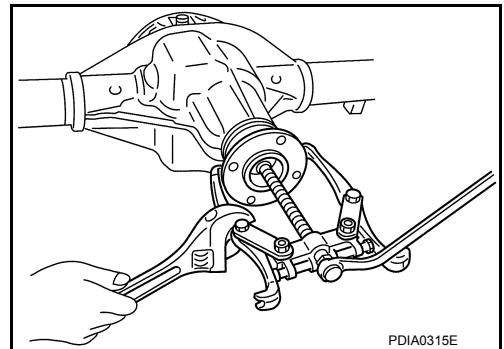

L
M
N
O

4. Remove oil seal/dust shield and discard.

CAUTION:

Do not reuse the differential oil seal.

P

REAR FINAL DRIVE

< UNIT DISASSEMBLY AND ASSEMBLY >

[REAR FINAL DRIVE: M226 (ELD)]

5. Remove front oil seal using Tool.

Tool number : ST33290001 (J-34286)

CAUTION:

Do not damage gear carrier.

6. Remove drive pinion front bearing thrust washer.

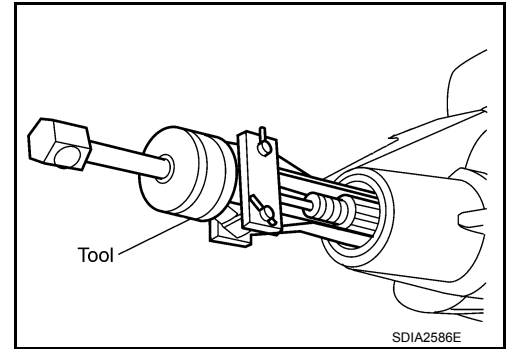

7. Remove drive pinion assembly (with rear inner bearing race and collapsible spacer) out of gear carrier.

CAUTION:

Do not drop drive pinion assembly.

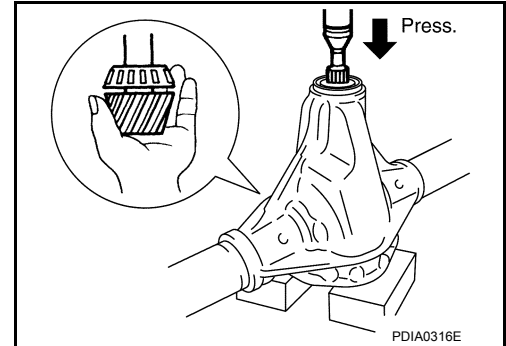

8. Remove collapsible spacer from drive pinion assembly and discard collapsible spacer.

CAUTION:

Do not reuse the collapsible spacer.

INSPECTION AFTER DISASSEMBLY

Clean the disassembled parts. Then inspect the parts for wear or damage. If wear or damage are found, follow the measures below.

Drive Pinion and Drive Gear

- If the gear teeth do not mesh or line-up correctly, replace with new rear final drive assembly. Refer to [DLN-322, "Removal and Installation"](#).
- If the gears are worn, cracked, damaged, pitted or chipped (by friction) noticeably, replace with new rear final drive assembly. Refer to [DLN-322, "Removal and Installation"](#).

Bearings

- If bearings are chipped (by friction), pitted, worn, rusted, scratched mark, or unusual noise from the bearing, replace with new rear final drive assembly. Refer to [DLN-322, "Removal and Installation"](#).

Differential Case Assembly

- If the gears are worn, cracked, damaged, pitted or chipped (by friction) noticeably, replace with new rear final drive assembly. Refer to [DLN-322, "Removal and Installation"](#).
- If the movement is not smooth when pushing cam ring of differential case assembly by hand. Replace with new rear final drive assembly. Refer to [DLN-322, "Removal and Installation"](#).

Differential Lock Solenoid

- If the operating part of differential lock solenoid is not smooth, perform component inspection. Refer to [DLN-276, "DIFFERENTIAL LOCK CONTROL UNIT : CONSULT Function \(DIFF LOCK\)"](#).

Companion Flange

- If any chips [about 0.1mm (0.004 in)] or other damage on the companion flange surface which contacts the front oil seal lips are found, replace with new one. Refer to [DLN-324, "Disassembly and Assembly"](#).

ASSEMBLY

Drive Pinion Assembly

1. Install drive pinion front bearing thrust washer.

REAR FINAL DRIVE

< UNIT DISASSEMBLY AND ASSEMBLY >

[REAR FINAL DRIVE: M226 (ELD)]

2. Apply multi-purpose grease to new front oil seal lip. Install new front oil seal into gear carrier using Tool.

Tool number : ST15310000 (—)

CAUTION:

- Do not reuse front oil seal.
- Do not incline the new front oil seal when installing.
- Apply multi-purpose grease to the lips of the new front oil seal.

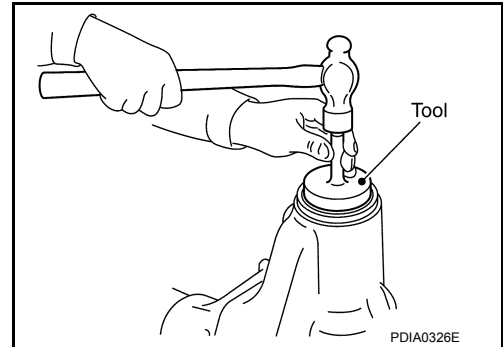

3. Install new collapsible spacer on drive pinion assembly. And then install drive pinion assembly into gear carrier.

CAUTION:

- Do not reuse collapsible spacer.
- Do not damage front oil seal.

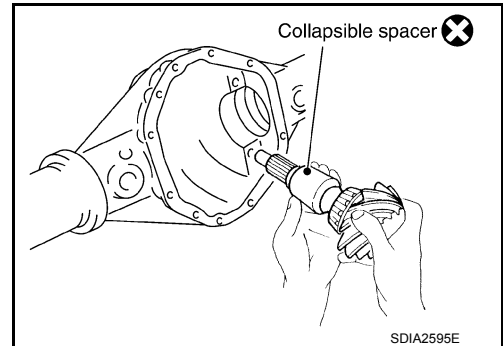

4. Install a new oil seal/dust shield.

CAUTION:

Do not reuse oil seal/dust shield.

5. Install the companion flange onto the drive pinion while aligning the matching marks. Then tap the companion flange using suitable tool.

CAUTION:

Do not damage companion flange or front oil seal.

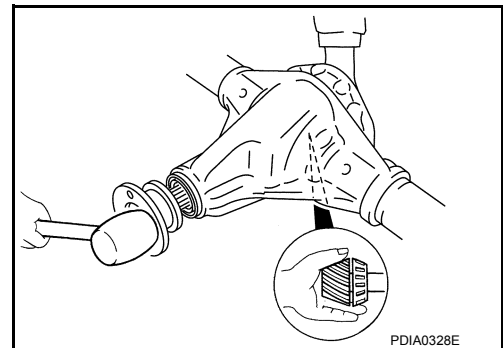

A
B
C
DLN
E
F
G
H
I
J
K
L
M
N
O
P

REAR FINAL DRIVE

< UNIT DISASSEMBLY AND ASSEMBLY >

[REAR FINAL DRIVE: M226 (ELD)]

6. Apply anti-corrosive oil to the threads of the drive pinion and the seating surface of the new drive pinion lock nut and new drive pinion lock nut washer. Then adjust the drive pinion lock nut tightening torque using suitable tool (A), and check the drive pinion bearing preload torque using Tool (B). Refer to [DLN-334, "Inspection and Adjustment"](#).

Tool number (B): ST3127S000 (J-25765-A)

CAUTION:

- Do not reuse drive pinion lock nut or drive pinion lock nut washer.
- Apply anti-corrosive oil to the threads of the drive pinion and the seating surface of the new drive pinion lock nut.
- Adjust the drive pinion lock nut tightening torque to the lower limit first. Do not exceed the drive pinion lock nut specified torque.
- If the drive pinion bearing preload torque exceeds the specified value, replace collapsible spacer and tighten it again to adjust. Do not loosen drive pinion lock nut to adjust the drive pinion bearing preload torque.
- After adjustment, rotate drive pinion back and forth 2 to 3 times to check for unusual noise, rotation malfunction, and other malfunctions.

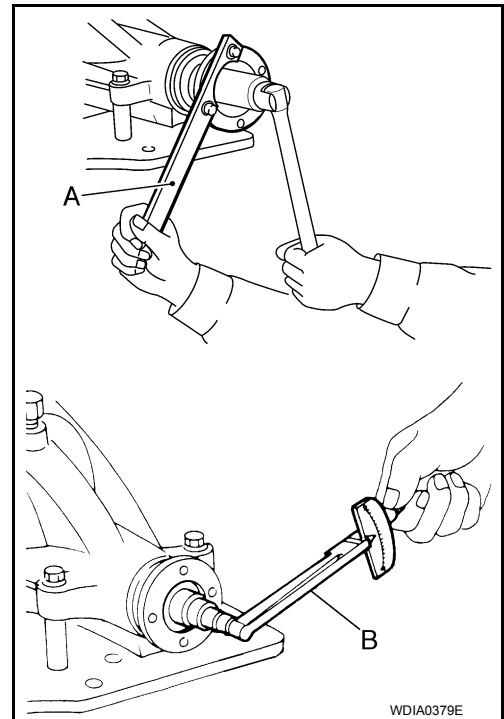

Differential Assembly

1. Apply sealant to threads of differential lock position switch.
 - Use Genuine Silicone RTV or equivalent. Refer to [GI-22, "Recommended Chemical Products and Sealants"](#).

CAUTION:

Remove old sealant adhering to gear carrier and differential lock position switch. Also remove any moisture, oil, or foreign material adhering to application and gear carrier and differential lock position switch.

2. Install differential lock position switch on gear carrier and tighten differential lock position switch bolts to the specified torque.

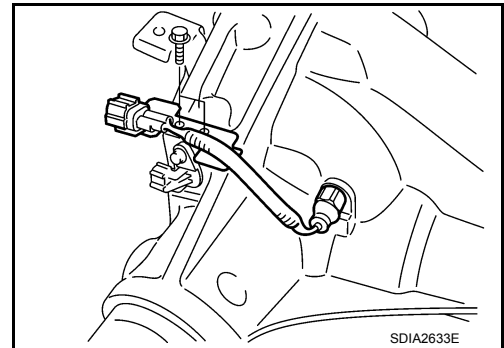

3. Apply gear oil to side bearings. Install differential case assembly with side bearing outer races into gear carrier.

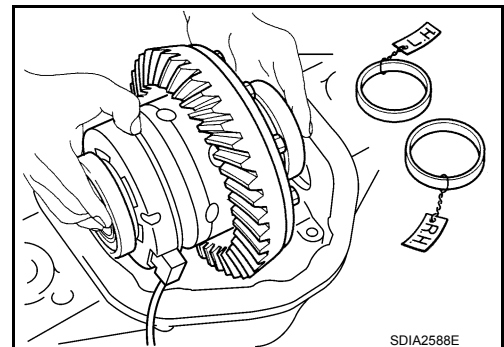

4. Apply multi-purpose grease to new sensor connector.

CAUTION:

Do not reuse sensor connector.

REAR FINAL DRIVE

< UNIT DISASSEMBLY AND ASSEMBLY >

[REAR FINAL DRIVE: M226 (ELD)]

5. Connect differential lock solenoid harness to new sensor connector. Then install new sensor connector to gear carrier and tighten to the specified torque.

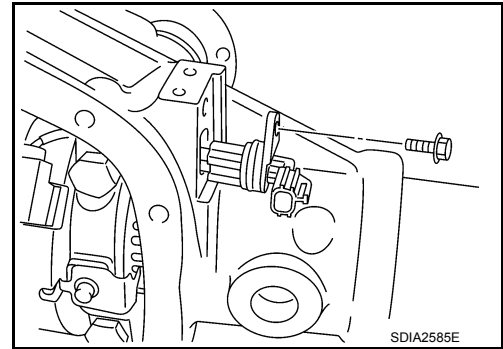

6. Align paint matching mark on side bearing caps with those on gear carrier and install side bearing caps on gear carrier.

CAUTION:

Do not tighten side bearing cap bolts at this point. This allows further tightening of side bearing adjusters.

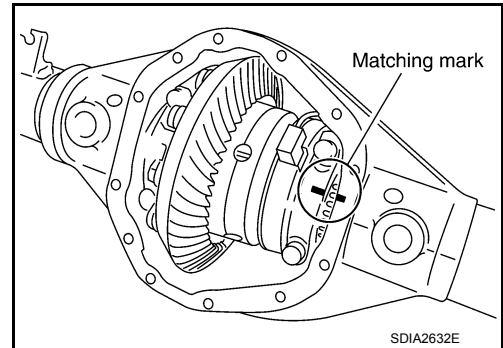

7. Tighten each side bearing adjusters using adjuster tool. Perform the following adjustments.

Tool number : — (C - 4164)

- Adjusting backlash of drive gear and drive pinion. Refer to [DLN-334, "Inspection and Adjustment"](#).
- Check total preload. Refer to [DLN-334, "Inspection and Adjustment"](#).
- Check tooth contact. Refer to [DLN-324, "Disassembly and Assembly"](#).

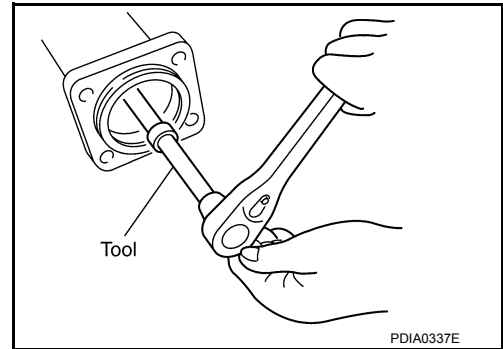

8. Apply a bead of sealant to the mating surface of the carrier cover as shown.

- Use Genuine Silicone RTV or equivalent. Refer to [GI-22, "Recommended Chemical Products and Sealants"](#).

CAUTION:

Remove any old sealant adhering to the mating surfaces. Also remove any moisture, oil, or foreign material adhering to the application and mating surfaces.

9. Install the carrier cover to the gear carrier. Tighten the bolts to the specified torque.

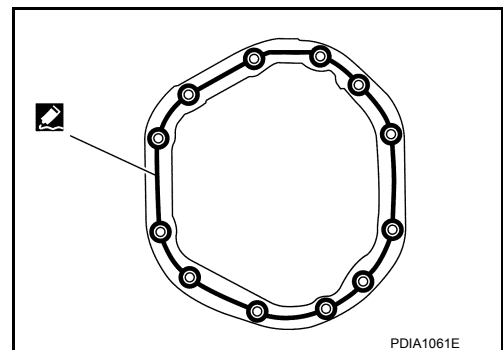

A
B
C
DLN
E
F
G
H
I
J
K
L
M
N
O
P

SERVICE DATA AND SPECIFICATIONS (SDS)

< SERVICE DATA AND SPECIFICATIONS (SDS)

[REAR FINAL DRIVE: M226 (ELD)]

SERVICE DATA AND SPECIFICATIONS (SDS)

SERVICE DATA AND SPECIFICATIONS (SDS)

General Specification

INFOID:000000007324098

Applied model	VQ40DE	
	4WD	
	5A/T	6M/T
Final drive model	M226	
Gear ratio	3.357	3.692
Number of teeth (Drive gear / drive pinion)	47/14	48/13
Oil capacity (Approx.)	ℓ (US pt, Imp pt)	2.01 (4-1/4, 3-1/2)
Drive pinion adjustment spacer type	Collapsible	

Inspection and Adjustment

INFOID:000000007324099

PRELOAD TORQUE

Unit: N·m (kg-m, in-lb)

Item	Specification
Drive pinion bearing preload torque	1.7 - 3.1 (0.18 - 0.31, 15 - 27)
Total preload torque (Total preload torque = drive pinion bearing preload torque + Side bearing preload torque)	2.38 - 4.46 (0.25 - 0.45, 21 - 39)

BACKLASH

Unit: mm (in)

Item	Standard
Drive gear to drive pinion gear	0.12 - 0.20 (0.0050 - 0.0078)

COMPANION FLANGE RUNOUT

Unit: mm (in)

Item	Limit
Companion flange face	0.13 (0.0051) or less
Companion flange inner side	