

SECTION **DLK**  
DOOR & LOCK

A  
B  
C

CONTENTS

<b>BASIC INSPECTION</b> .....	4	REMOTE KEYLESS ENTRY : Component Parts	F
<b>DIAGNOSIS AND REPAIR WORKFLOW</b> .....	4	Location - King Cab .....	17
Work Flow .....	4	REMOTE KEYLESS ENTRY : Component Parts	G
<b>INSPECTION AND ADJUSTMENT</b> .....	7	Location - Crew Cab .....	18
<b>ADDITIONAL SERVICE WHEN REPLACING CONTROL UNIT</b> .....	7	REMOTE KEYLESS ENTRY : Component Description .....	18
ADDITIONAL SERVICE WHEN REPLACING CONTROL UNIT : Description .....	7	<b>HOMELINK UNIVERSAL TRANSCEIVER</b> .....	19
ADDITIONAL SERVICE WHEN REPLACING CONTROL UNIT : Special Repair Requirement .....	7	Component Description .....	19
<b>SYSTEM DESCRIPTION</b> .....	8	<b>DIAGNOSIS SYSTEM (BCM)</b> .....	20
<b>AUTOMATIC DOOR LOCKS</b> .....	8	<b>COMMON ITEM</b> .....	20
System Diagram .....	8	COMMON ITEM : CONSULT Function (BCM - COMMON ITEM) .....	20
System Description .....	8	<b>DOOR LOCK</b> .....	20
Component Parts Location - King Cab .....	10	DOOR LOCK : CONSULT Function (BCM - DOOR LOCK) .....	21
Component Parts Location - Crew Cab .....	11	<b>MULTI REMOTE ENT</b> .....	21
Component Description .....	11	MULTI REMOTE ENT : CONSULT Function (BCM - MULTI REMOTE ENT) .....	21
<b>DOOR LOCK FUNCTION</b> .....	12	<b>DTC/CIRCUIT DIAGNOSIS</b> .....	23
<b>DOOR LOCK AND UNLOCK SWITCH</b> .....	12	<b>U1000 CAN COMM CIRCUIT</b> .....	23
DOOR LOCK AND UNLOCK SWITCH : System Diagram .....	12	Description .....	23
DOOR LOCK AND UNLOCK SWITCH : System Description .....	12	DTC Logic .....	23
DOOR LOCK AND UNLOCK SWITCH : Component Parts Location - King Cab .....	13	Diagnosis Procedure .....	23
DOOR LOCK AND UNLOCK SWITCH : Component Parts Location - Crew Cab .....	14	<b>U1010 CONTROL UNIT (CAN)</b> .....	24
DOOR LOCK AND UNLOCK SWITCH : Component Description .....	14	DTC Logic .....	24
<b>REMOTE KEYLESS ENTRY</b> .....	14	Diagnosis Procedure .....	24
REMOTE KEYLESS ENTRY : System Diagram ....	14	Special Repair Requirement .....	24
REMOTE KEYLESS ENTRY : System Description .....	15	<b>POWER SUPPLY AND GROUND CIRCUIT</b> ....	25
		Diagnosis Procedure .....	25
		<b>DOOR SWITCH</b> .....	27
		<b>KING CAB</b> .....	27
		KING CAB : Description .....	27

D

E

F

G

H

I

J

**DLK**

L

M

N

O

P

KING CAB : Component Function Check .....	27	<b>HORN FUNCTION .....</b>	<b>53</b>
KING CAB : Diagnosis Procedure .....	27	Description .....	53
<b>CREW CAB .....</b>	<b>29</b>	Component Function Check .....	53
CREW CAB : Description .....	29	Diagnosis Procedure .....	53
CREW CAB : Component Function Check .....	29	<b>WARNING CHIME FUNCTION .....</b>	<b>55</b>
CREW CAB : Diagnosis Procedure .....	29	Description .....	55
<b>DOOR LOCK AND UNLOCK SWITCH .....</b>	<b>32</b>	Component Function Check .....	55
<b>KING CAB .....</b>	<b>32</b>	Diagnosis Procedure .....	55
KING CAB : Description .....	32	<b>HAZARD FUNCTION .....</b>	<b>56</b>
KING CAB : Component Function Check .....	32	Description .....	56
KING CAB : Diagnosis Procedure .....	32	Component Function Check .....	56
<b>CREW CAB .....</b>	<b>35</b>	Diagnosis Procedure .....	56
CREW CAB : Description .....	35	<b>HEADLAMP FUNCTION .....</b>	<b>57</b>
CREW CAB : Component Function Check .....	35	Diagnosis Procedure .....	57
CREW CAB : Diagnosis Procedure .....	35	<b>MAP LAMP AND IGNITION KEYHOLE ILLU- MINATION FUNCTION .....</b>	<b>58</b>
<b>KEY CYLINDER SWITCH .....</b>	<b>39</b>	Diagnosis Procedure .....	58
<b>DRIVER SIDE .....</b>	<b>39</b>	<b>KEYFOB ID SET UP WITH CONSULT .....</b>	<b>59</b>
DRIVER SIDE : Description .....	39	ID Code Entry Procedure .....	59
DRIVER SIDE : Component Function Check .....	39	<b>KEYFOB ID SET UP WITHOUT CONSULT ....</b>	<b>60</b>
DRIVER SIDE : Diagnosis Procedure .....	39	ID Code Entry Procedure .....	60
<b>KEY SWITCH (BCM INPUT) .....</b>	<b>42</b>	<b>HOMELINK UNIVERSAL TRANSCEIVER .....</b>	<b>62</b>
Diagnosis Procedure .....	42	Description .....	62
<b>DOOR LOCK ACTUATOR .....</b>	<b>43</b>	Component Function Check .....	62
<b>DRIVER SIDE .....</b>	<b>43</b>	Diagnosis Procedure .....	62
DRIVER SIDE : Description .....	43	<b>ECU DIAGNOSIS INFORMATION .....</b>	<b>64</b>
DRIVER SIDE : Component Function Check .....	43	<b>BCM (BODY CONTROL MODULE) .....</b>	<b>64</b>
DRIVER SIDE : Diagnosis Procedure .....	43	Reference Value .....	64
<b>PASSENGER SIDE .....</b>	<b>44</b>	Terminal Layout .....	67
PASSENGER SIDE : Description .....	44	Physical Values .....	67
PASSENGER SIDE :		Fail Safe .....	72
Component Function Check .....	44	DTC Inspection Priority Chart .....	72
PASSENGER SIDE : Diagnosis Procedure .....	44	DTC Index .....	73
<b>REAR LH .....</b>	<b>45</b>	<b>WIRING DIAGRAM .....</b>	<b>75</b>
REAR LH : Description .....	45	<b>INTEGRATED HOMELINK TRANSMITTER ....</b>	<b>75</b>
REAR LH : Component Function Check .....	45	Wiring Diagram .....	75
REAR LH : Diagnosis Procedure .....	45	<b>POWER DOOR LOCK SYSTEM .....</b>	<b>77</b>
<b>REAR RH .....</b>	<b>46</b>	Wiring Diagram - King Cab .....	77
REAR RH : Description .....	47	Wiring Diagram - Crew Cab .....	87
REAR RH : Component Function Check .....	47	<b>REMOTE KEYLESS ENTRY SYSTEM .....</b>	<b>97</b>
REAR RH : Diagnosis Procedure .....	47	Wiring Diagram - King Cab .....	97
<b>REMOTE KEYLESS ENTRY RECEIVER .....</b>	<b>49</b>	Wiring Diagram - Crew Cab .....	107
Description .....	49	<b>SYMPTOM DIAGNOSIS .....</b>	<b>116</b>
Component Function Check .....	49	<b>DOOR LOCK .....</b>	<b>116</b>
Diagnosis Procedure .....	49	Symptom Table .....	116
<b>KEYFOB BATTERY AND FUNCTION .....</b>	<b>51</b>	<b>REMOTE KEYLESS ENTRY SYSTEM .....</b>	<b>117</b>
Description .....	51		
Component Function Check .....	51		
Diagnosis Procedure .....	51		

Symptom Table .....	117	<b>HOOD</b> .....	<b>127</b>	
<b>SQUEAK AND RATTLE TROUBLE DIAG- NOSES</b> .....	<b>119</b>	Fitting Adjustment .....	127	A
Work Flow .....	119	Removal and Installation of Hood Assembly .....	128	
Generic Squeak and Rattle Troubleshooting .....	121	Removal and Installation of Hood Lock Control ...	129	B
Diagnostic Worksheet .....	123	Hood Lock Control Inspection .....	130	
<b>PRECAUTION</b> .....	<b>125</b>	<b>DOOR</b> .....	<b>131</b>	C
<b>PRECAUTIONS</b> .....	<b>125</b>	Fitting Adjustment .....	131	
Precaution for Supplemental Restraint System (SRS) "AIR BAG" and "SEAT BELT PRE-TEN- SIONER" .....	125	Removal and Installation .....	133	D
Precaution for Work Door and Lock .....	125	<b>FRONT DOOR LOCK</b> .....	<b>136</b>	
<b>PREPARATION</b> .....	<b>126</b>	Component Structure .....	136	E
<b>PREPARATION</b> .....	<b>126</b>	Removal and Installation .....	136	
Special Service Tool .....	126	Disassembly and Assembly .....	138	F
Commercial Service Tool .....	126	<b>REAR DOOR LOCK</b> .....	<b>139</b>	
<b>REMOVAL AND INSTALLATION</b> .....	<b>127</b>	Component Structure .....	139	G
		Removal and Installation .....	140	
		<b>TAIL GATE</b> .....	<b>143</b>	H
		Removal and Installation .....	143	
				I
				J
				DLK
				L
				M
				N
				O
				P

# DIAGNOSIS AND REPAIR WORKFLOW

< BASIC INSPECTION >

## BASIC INSPECTION

### DIAGNOSIS AND REPAIR WORKFLOW

Work Flow

INFOID:000000008792237

OVERALL SEQUENCE

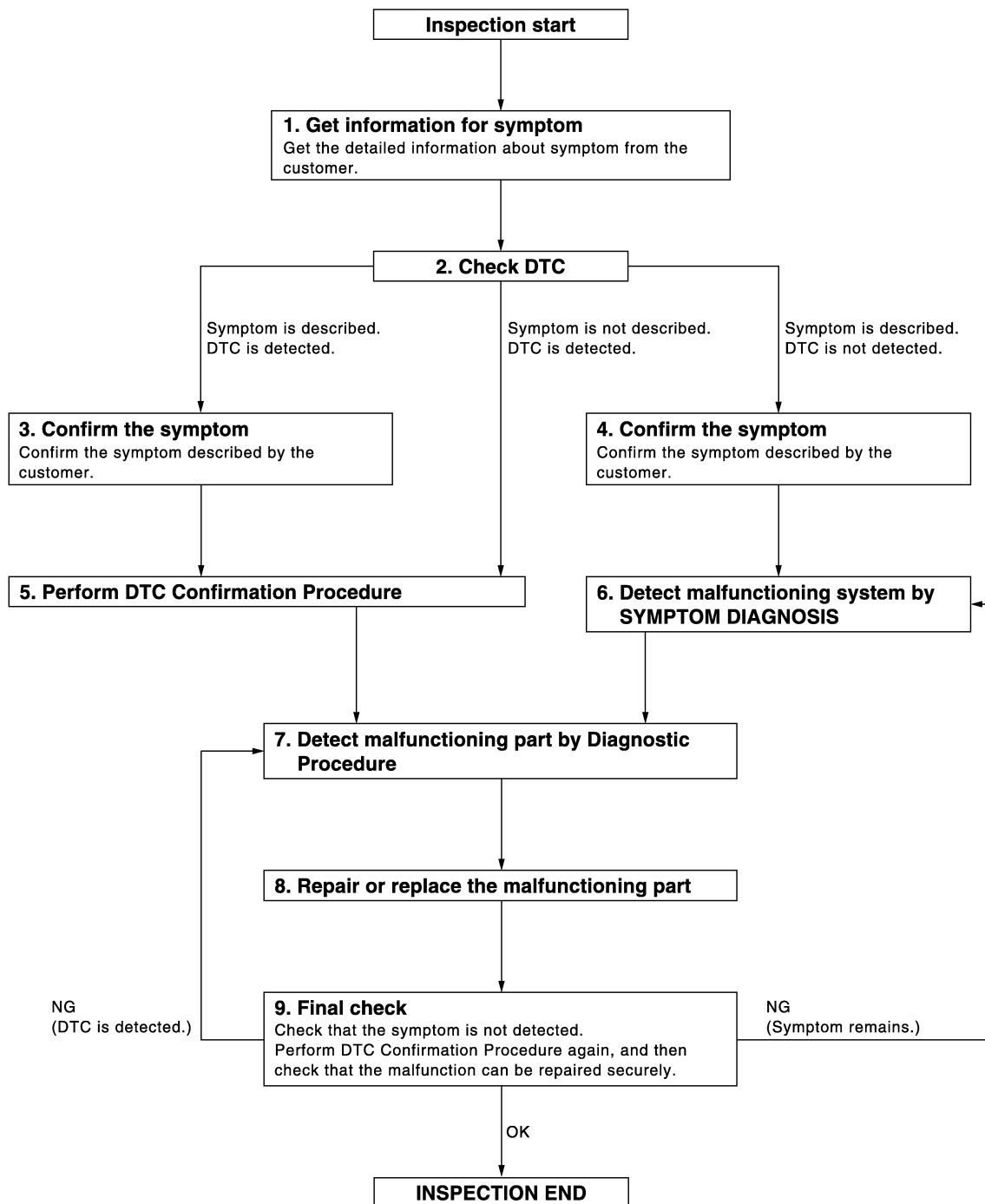

JMKIA2270GB

DETAILED FLOW

# DIAGNOSIS AND REPAIR WORKFLOW

## < BASIC INSPECTION >

### 1. GET INFORMATION FOR SYMPTOM

Get the detailed information from the customer about the symptom (the condition and the environment when the incident/malfunction occurred).

>> GO TO 2

### 2. CHECK DTC

1. Check DTC.
2. Perform the following procedure if DTC is displayed.
  - Record DTC and freeze frame data (Print them out with CONSULT).
  - Erase DTC.
  - Study the relationship between the cause detected by DTC and the symptom described by the customer.
3. Check related service bulletins for information.

Is any symptom described and any DTC detected?

Symptom is described, DTC is displayed>>GO TO 3

Symptom is described, DTC is not displayed>>GO TO 4

Symptom is not described, DTC is displayed>>GO TO 5

### 3. CONFIRM THE SYMPTOM

Confirm the symptom described by the customer.

Connect CONSULT to the vehicle in "DATA MONITOR" mode and check real time diagnosis results. Verify relation between the symptom and the condition when the symptom is detected.

>> GO TO 5

### 4. CONFIRM THE SYMPTOM

Confirm the symptom described by the customer.

Connect CONSULT to the vehicle in "DATA MONITOR" mode and check real time diagnosis results. Verify relation between the symptom and the condition when the symptom is detected.

>> GO TO 6

### 5. PERFORM DTC CONFIRMATION PROCEDURE

Perform DTC Confirmation Procedure for the displayed DTC, and then check that DTC is detected again. At this time, always connect CONSULT to the vehicle, and check diagnostic results in real time.

If two or more DTCs are detected, refer to [BCS-40. "DTC Inspection Priority Chart"](#) and determine trouble diagnosis order.

#### NOTE:

- Freeze frame data is useful if the DTC is not detected.
- Perform Component Function Check if DTC Confirmation Procedure is not included in Service Manual. This simplified check procedure is an effective alternative though DTC cannot be detected during this check. If the result of Component Function Check is NG, it is the same as the detection of DTC by DTC Confirmation Procedure.

Is DTC detected?

YES >> GO TO 7

NO >> Refer to [GI-49. "Intermittent Incident"](#).

### 6. DETECT MALFUNCTIONING SYSTEM BY SYMPTOM TABLE

Detect malfunctioning system according to SYMPTOM DIAGNOSIS based on the confirmed symptom in step 4, and determine the trouble diagnosis order based on possible causes and symptom.

>> GO TO 7

### 7. DETECT MALFUNCTIONING PART BY DIAGNOSTIC PROCEDURE

Inspect according to Diagnostic Procedure of the system.

#### NOTE:

A  
B  
C  
D  
E  
F  
G  
H  
I  
J  
L  
M  
N  
O  
P

DLK

## DIAGNOSIS AND REPAIR WORKFLOW

### < BASIC INSPECTION >

---

The Diagnostic Procedure described based on open circuit inspection. A short circuit inspection is also required for the circuit check in the Diagnostic Procedure.

#### Is malfunctioning part detected?

YES >> GO TO 8

NO >> Check voltage of related BCM terminals using CONSULT.

### 8. REPAIR OR REPLACE THE MALFUNCTIONING PART

---

1. Repair or replace the malfunctioning part.
2. Reconnect parts or connectors disconnected during Diagnostic Procedure again after repair and replacement.
3. Check DTC. If DTC is displayed, erase it.

>> GO TO 9

### 9. FINAL CHECK

---

When DTC was detected in step 2, perform DTC Confirmation Procedure or Component Function Check again, and then check that the malfunction have been repaired securely.

When symptom was described from the customer, refer to confirmed symptom in step 3 or 4, and check that the symptom is not detected.

#### Is the inspection result normal?

NO (DTC is detected)>>GO TO 7

NO (Symptom remains)>>GO TO 6

YES >> Inspection End.

# INSPECTION AND ADJUSTMENT

< BASIC INSPECTION >

## INSPECTION AND ADJUSTMENT

ADDITIONAL SERVICE WHEN REPLACING CONTROL UNIT

A

ADDITIONAL SERVICE WHEN REPLACING CONTROL UNIT : Description

INFOID:000000008792238

B

Perform the system initialization when replacing BCM, replacing a keyfob or registering an additional keyfob.

ADDITIONAL SERVICE WHEN REPLACING CONTROL UNIT : Special Repair Requirement

INFOID:000000008792239

C

Refer to the CONSULT Immobilizer mode and follow the on-screen instructions.

D

E

F

G

H

I

J

**DLK**

L

M

N

O

P

# AUTOMATIC DOOR LOCKS

< SYSTEM DESCRIPTION >

## SYSTEM DESCRIPTION

### AUTOMATIC DOOR LOCKS

#### System Diagram

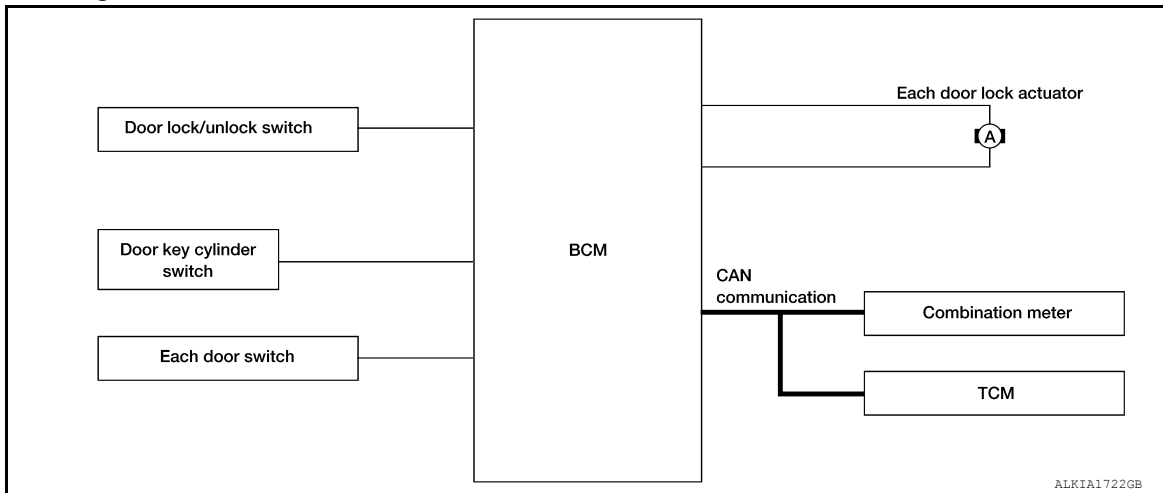

#### System Description

INFOID:000000008792241

Input	Single	Function	Actuator
Door lock/unlock switch	Door lock/unlock signal	Door lock function	Each door lock actuator
Door key cylinder switch			
Each door switch	Door open/close signal	Key reminder function	
Combination meter	Warning buzzer signal		
	Vehicle speed signal	Automatic door lock/unlock function	
TCM	Shift position signal		

#### DOOR LOCK FUNCTION

- The door lock and unlock switch (driver side) is built into power window main switch.
- The door lock and unlock switch (passenger side) is on door trim.
- Interlocked with the locking operation of door lock and unlock switch, door lock actuators of all doors are locked.
- Interlocked with the unlocking operation of door lock and unlock switch, door lock actuators of all doors are unlocked.

#### Door Key Cylinder

- With the door key inserted in the door key cylinder on driver side, turning it to “LOCK”, will lock door lock actuator of all doors.
- With the door key inserted in the door key cylinder on driver side, turning it to “UNLOCK” once unlocks the driver side door lock actuator; turning it to “UNLOCK” again within 5 seconds after the first unlock operation unlocks all of the other doors. - (SELECTIVE UNLOCK OPERATION)

Selective unlock operation mode can be changed using “DOOR LOCK-UNLOCK SET” mode in “WORK SUPPORT”. Refer to [BCS-15, "DOOR LOCK : CONSULT Function \(BCM - DOOR LOCK\)"](#).

#### AUTOMATIC DOOR LOCKS (LOCK OPERATION)

The interlock door lock function is the function that locks all doors linked with the vehicle speed.

#### Vehicle Speed Sensing Auto Door Lock\*1

All doors are locked when the vehicle speed reaches 24 km/h (15 MPH) or more.

BCM outputs the lock signal to all door lock actuators when it detects that the ignition switch is turned ON, all doors are closed and the vehicle speed received from the combination meter via CAN communication becomes 15 MPH (24 km/h) or more.



# AUTOMATIC DOOR LOCKS

## < SYSTEM DESCRIPTION >

If a door is opened and closed at any time during one ignition cycle (OFF → ON), even after initial auto door lock has taken place, the BCM will relock all doors when the vehicle speed reaches 15 MPH (24 km/h) or more again.

Setting change of Automatic Door Locks (LOCK) Function

The lock operation setting of the automatic door locks function can be changed.

### **With CONSULT**

The ON/OFF switching of the automatic door locks (LOCK) function and the type selection of the automatic door locks (LOCK) function can be performed at the WORK SUPPORT setting of CONSULT. Refer to [BCS-15, "DOOR LOCK : CONSULT Function \(BCM - DOOR LOCK\)"](#).

### **Without CONSULT**

The automatic door locks (LOCK) function can be switched ON/OFF by performing the following operation.

1. Close all doors (door switch OFF).
2. Turn ignition switch ON.
3. Within 20 seconds of turning the ignition switch ON, press and hold the door lock and unlock switch to the LOCK position for more than 5 seconds.
4. The switching is completed when the hazard lamps blink.

OFF → ON : 2 blinks

ON → OFF : 1 blink

5. The ignition switch must be turned OFF and ON again between each setting change.

## AUTOMATIC DOOR LOCKS (UNLOCK OPERATION)

The automatic door locks (UNLOCK) function is the function that unlocks all doors linked with the key position.

IGN OFF Interlock Door Unlock\*1

All doors are unlocked when the power supply position is changed from ON to OFF.

BCM outputs the unlock signal to all door lock actuators when it detects that the power supply position is changed from ignition switch ON to OFF.

Setting change of Automatic Door Locks (UNLOCK) Function

The lock operation setting of the automatic door locks function can be changed.

### **With CONSULT**

The ON/OFF switching of the automatic door locks (UNLOCK) function and the type selection of the automatic door locks (UNLOCK) function can be performed at the WORK SUPPORT setting of CONSULT. Refer to [BCS-15, "DOOR LOCK : CONSULT Function \(BCM - DOOR LOCK\)"](#).

### **Without CONSULT**

The automatic door locks (UNLOCK) function can be switched ON/OFF by performing the following operation.

1. Close all doors (door switch OFF).
2. Turn ignition switch ON.
3. Within 20 seconds of turning the ignition switch ON, press and hold the door lock and unlock switch to the UNLOCK position for more than 5 seconds.
4. The switching is completed when the hazard lamps blink.

OFF → ON : 2 blinks

ON → OFF : 1 blink

5. The ignition switch must be turned OFF and ON again between each setting change.

\*1: This function is set to ON before delivery.

# AUTOMATIC DOOR LOCKS

< SYSTEM DESCRIPTION >

## Component Parts Location - King Cab

INFOID:000000008792242

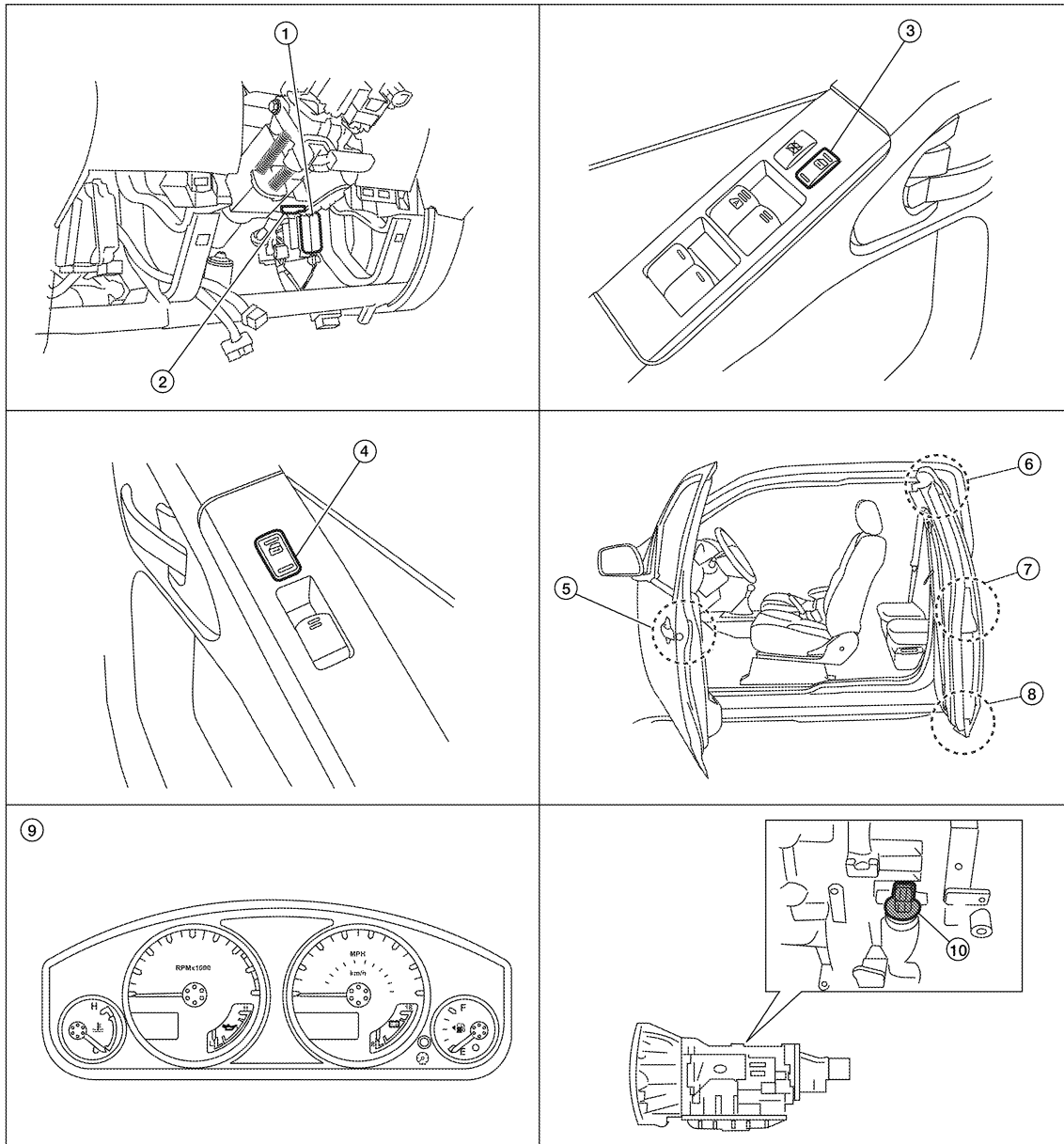

ALR1A1723Z2

- |   |  |   |
|---|--|---|
| 1. BCM M18, M19, M20<br>(view with lower instrument panel LH removed) | 2. Key switch M27  | 3. Main power window and door lock/unlock switch D7 |
| 4. Power window and door lock/unlock switch RH D105                   | 5. Front door lock assembly LH (key cylinder switch) D14<br>Front door lock actuator RH D114 | 6. Rear door switch upper LH D211<br>RH D312        |
| 7. Front door switch LH D213<br>RH D314                               | 8. Rear door switch lower LH D212<br>RH D313   | 9. Combination meter M24                            |
| 10. A/T assembly (TCM) F9   |  |   |

# AUTOMATIC DOOR LOCKS

< SYSTEM DESCRIPTION >

## Component Parts Location - Crew Cab

INFOID:000000008792243

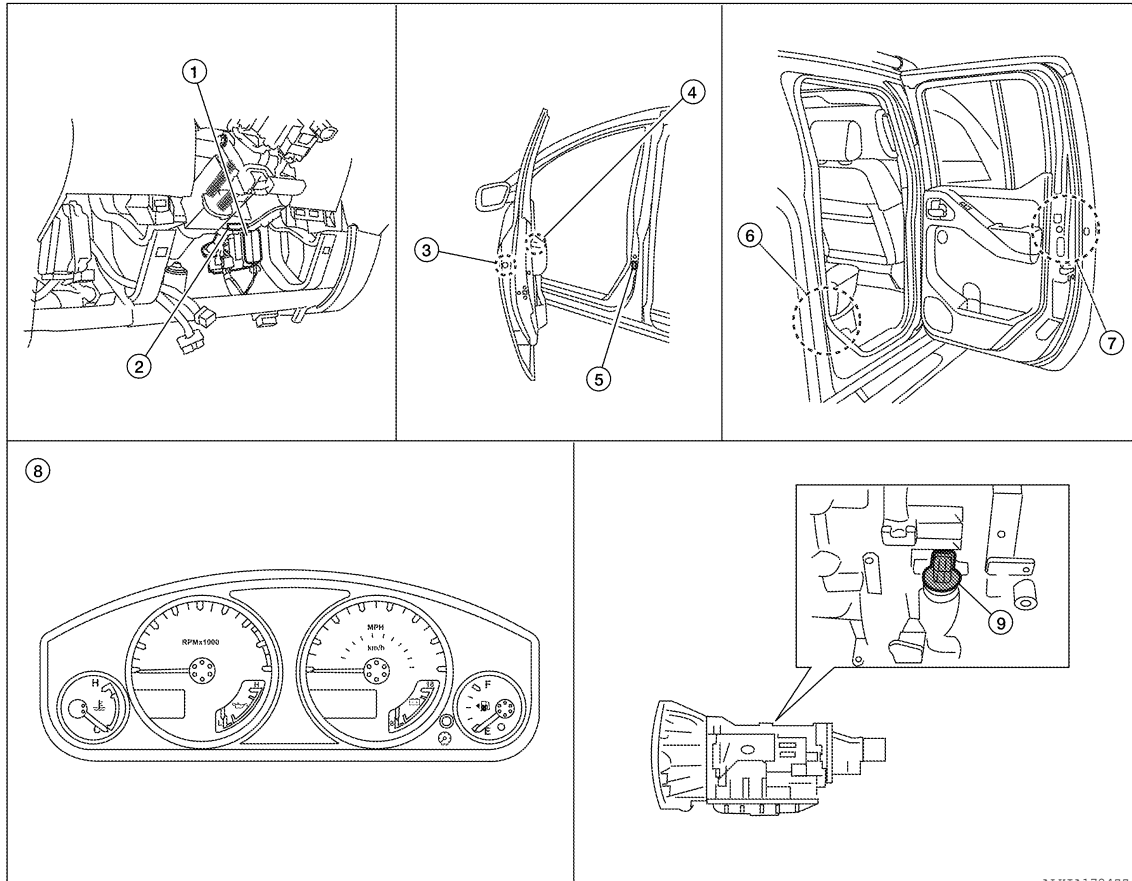

A  
B  
C  
D  
E  
F  
G  
H  
I  
J

- |   |                                       |  |
|---|---------------------------------------|--|
| 1. BCM M18, M19, M20<br>(view with lower instrument panel LH removed)                                   | 2. Key switch M27                     | 3. Front door lock assembly LH (key cylinder switch) D14<br>Front door lock actuator RH D114 |
| 4. Main power window and door lock/unlock switch D7<br>Power window and door lock/unlock switch RH D105 | 5. Front door switch LH B8<br>RH B108 | 6. Rear door switch LH B18<br>RH B116  |
| 7. Rear door lock actuator LH D205<br>RH D305   | 8. Combination meter M24              | 9. A/T assembly (TCM) F9   |

DLK

L  
M

## Component Description

INFOID:000000008792244

Item	Function
BCM	Controls the door lock function and room lamp function.
Door lock and unlock switch	Input lock or unlock signal to BCM.
Door lock actuator	Output lock/unlock signal from BCM and locks/unlocks each door.
Door switch	Input door open/close condition to BCM.
Door key cylinder switch	<ul style="list-style-type: none"> <li>Input lock or unlock signal to main power window and door lock/unlock switch.</li> <li>Main power window and door lock/unlock switch transmits door lock/unlock signal to BCM.</li> </ul>
Combination meter	<ul style="list-style-type: none"> <li>Receive buzzer signal from BCM via CAN communication line, and sounds the buzzer.</li> <li>Transmits vehicle speed signal to CAN communication line.</li> </ul>
TCM	Transmit shift position signal to BCM via CAN communication line.

N  
O  
P

# DOOR LOCK FUNCTION

< SYSTEM DESCRIPTION >

## DOOR LOCK FUNCTION DOOR LOCK AND UNLOCK SWITCH

### DOOR LOCK AND UNLOCK SWITCH : System Diagram

INFOID:000000008792245

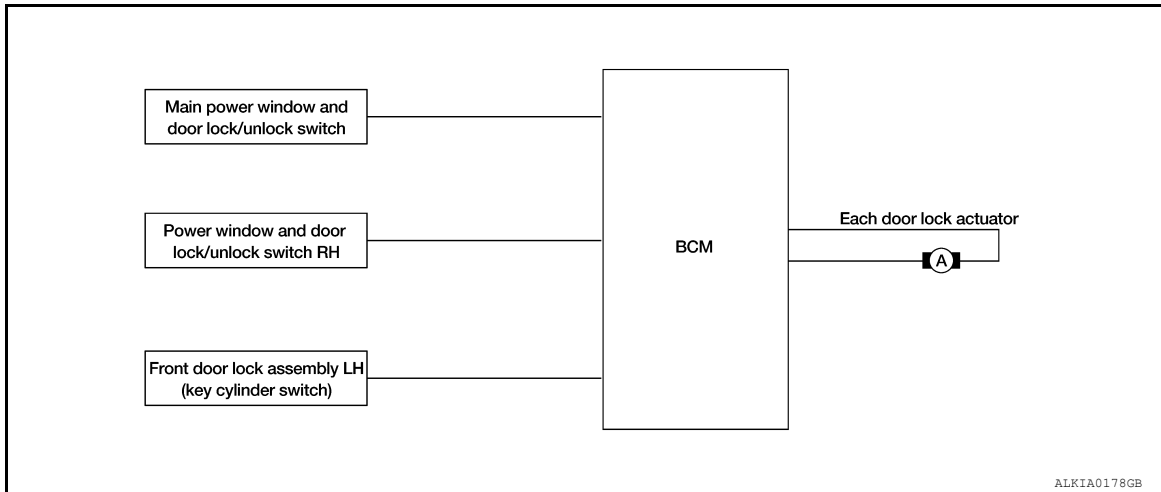

ALKIA0178GB

### DOOR LOCK AND UNLOCK SWITCH : System Description

INFOID:000000008792246

Switch	Input/output signal to BCM	BCM function	Actuator
Main power window and door lock/unlock switch	Door lock/unlock signal	Door lock/unlock control	Door lock actuator
Power window and door lock/unlock switch			
Front door key cylinder switch			

### DOOR LOCK FUNCTION

Functions Available by Operating the Door Lock and Unlock Switches on Driver Door and Passenger Door

- Interlocked with the locking operation of door lock and unlock switch, door lock actuators of all door lock actuators are locked.
- Interlocked with the unlocking operation of door lock and unlock switch, door lock actuators of all door lock actuators are unlocked.

Functions Available by Operating the Key Cylinder Switch on Driver Door

- Interlocked with the locking operation of door key cylinder, door lock actuators of all door lock actuators are locked.

Selective Unlock Operation

- When driver door key cylinder is unlocked, door lock actuator driver side is unlocked.
- When driver door key cylinder is unlocked for the second time within 5 seconds after the first operation, door lock actuators on all doors are unlocked.

Select unlock operation mode can be changed using AUTOMATIC DOOR UNLOCK SELECT mode in "WORK SUPPORT". Refer to [BCS-15, "DOOR LOCK : CONSULT Function \(BCM - DOOR LOCK\)"](#).

Key Reminder System

Refer to [DLK-42, "Diagnosis Procedure"](#).

# DOOR LOCK FUNCTION

< SYSTEM DESCRIPTION >

## DOOR LOCK AND UNLOCK SWITCH : Component Parts Location - King Cab

INFOID:000000008792247

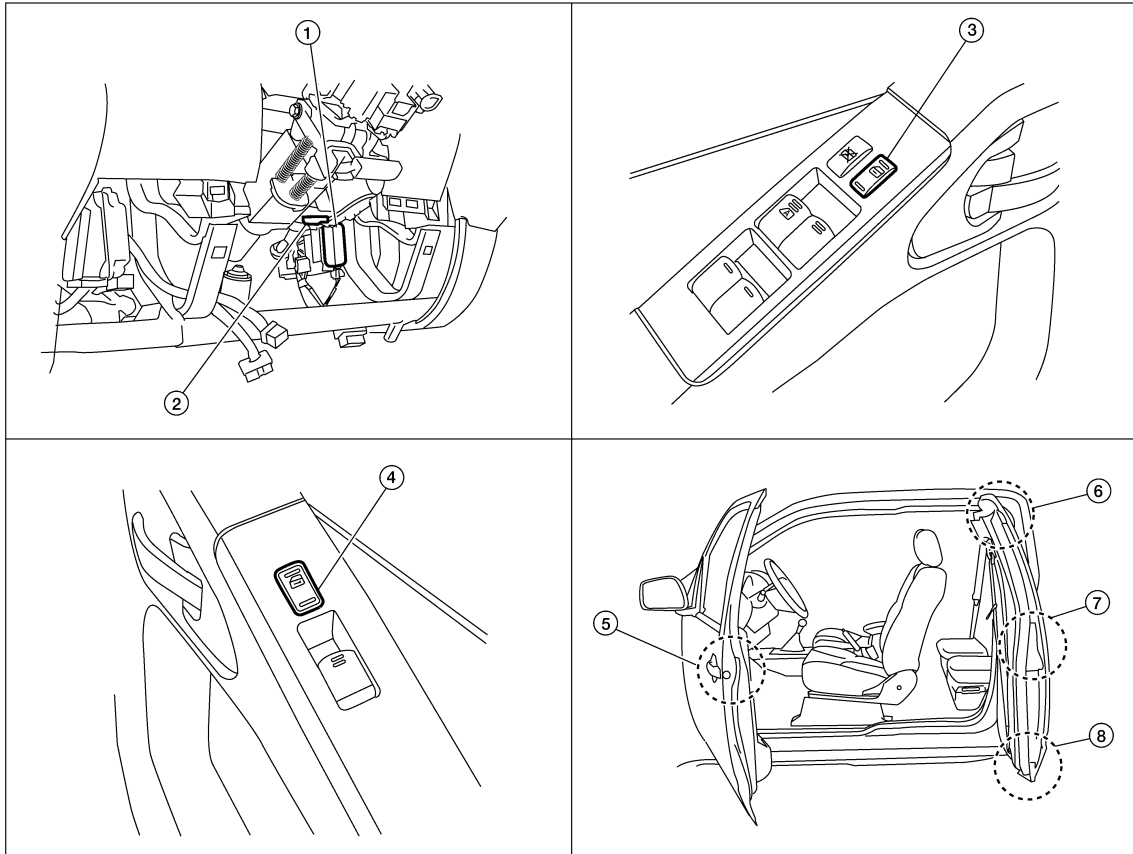

ALKIA13832Z

- |   |  |   |
|---|--|---|
| 1. BCM M18, M19, M20<br>(view with lower instrument panel LH removed) | 2. Key switch M27  | 3. Main power window and door lock/unlock switch D7 |
| 4. Power window and door lock/unlock switch RH D105                   | 5. Front door lock assembly LH (key cylinder switch) D14<br>Front door lock actuator RH D114 | 6. Rear door switch upper LH D211<br>RH D312        |
| 7. Front door switch<br>LH D213<br>RH D314                            | 8. Rear door switch lower<br>LH D212<br>RH D313  |   |

A  
B  
C  
D  
E  
F  
G  
H  
I  
J

DLK

L  
M  
N  
O  
P

# DOOR LOCK FUNCTION

< SYSTEM DESCRIPTION >

## DOOR LOCK AND UNLOCK SWITCH : Component Parts Location - Crew Cab

INFOID:000000008792248

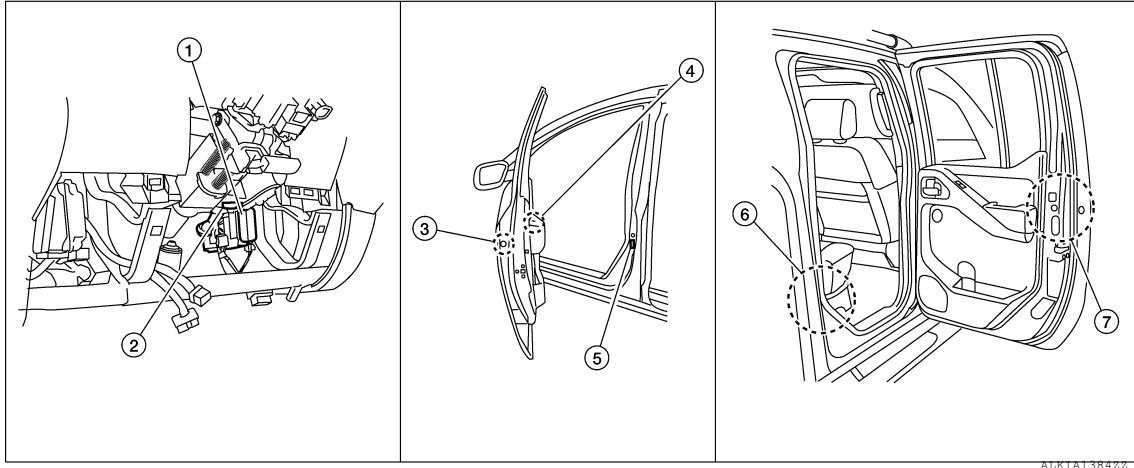

- |   |  |  |
|---|--|--|
| <p>1. BCM M18, M19, M20<br/>(view with lower instrument panel LH removed)</p> <p>4. Main power window and door lock/unlock switch D7<br/>Power window and door lock/unlock switch RH D105</p> <p>7. Rear door lock actuator<br/>LH D205<br/>RH D305</p> | <p>2. Key switch M27</p> <p>5. Front door switch<br/>LH B8<br/>RH B108</p> | <p>3. Front door lock assembly LH (key cylinder switch) D14<br/>Front door lock actuator RH D114</p> <p>6. Rear door switch<br/>LH B18<br/>RH B116</p> |
|---|--|--|

## DOOR LOCK AND UNLOCK SWITCH : Component Description

INFOID:000000008792249

Item	Function
BCM	Controls the door lock function and room lamp function.
Door lock and unlock switch	Transmits lock or unlock signal to BCM.
Door lock actuator	Receives lock/unlock signal from BCM and locks/unlocks each door.
Door switch	Transmits door open/close condition to BCM.

## REMOTE KEYLESS ENTRY

### REMOTE KEYLESS ENTRY : System Diagram

INFOID:000000008792250

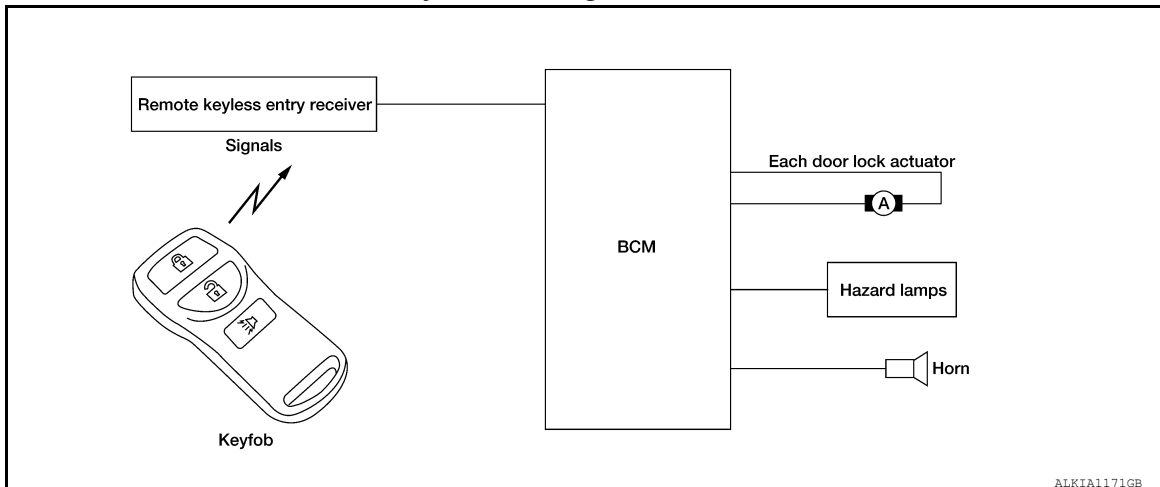

# DOOR LOCK FUNCTION

< SYSTEM DESCRIPTION >

## REMOTE KEYLESS ENTRY : System Description

INFOID:000000008792251

### OPERATED PROCEDURE

- When the keyfob is operated, the signal from the keyfob is sent and the remote keyless entry receiver receives the signal and sends it to the BCM. The BCM only locks/unlocks the doors if the ID number matches. (Remote control entry functions)
- Using the keyfob, the transmitter sends radio waves to the remote keyless entry receiver, which then sends the received waves to the BCM. Only if the ID number matches does the BCM lock/unlock the doors. (Remote control door function)
- Unless the key is inserted into the ignition key cylinder or one of the doors is opened within 1 minute after the UNLOCK switch on the keyfob is pressed, all the doors are automatically locked. (Auto lock function)
- When a door is locked or unlocked, the vehicle turn signal lamps flash and the horn sounds to verify operation. (Active check function)
- When the key is in the ignition key cylinder (when the key switch is ON) and one of the doors is open, the door lock function does not work even when the door lock is operated with the keyfob.
- Keyfob ID set up is available.
- If a keyfob is lost, a new keyfob can be set up. A maximum of 5 IDs can be set up simultaneously.

### REMOTE CONTROL ENTRY FUNCTIONS

- When a button on the keyfob is operated, the signal is sent from the keyfob and received by the remote keyless entry receiver.
- The received signal is sent to the BCM and compared with the registered ID number.
- If the ID number matches, the BCM sends the lock/unlock signal to each door lock actuator.
- When the door lock actuators receive this signal, each operates to lock/unlock its door.
- BCM locks all doors with input of LOCK signal from keyfob.
- When an UNLOCK signal is sent from keyfob once, driver's door will be unlocked.
- Then, if an UNLOCK signal is sent from keyfob again within 5 seconds, all other doors will be unlocked.

### REMOTE CONTROL ENTRY OPERATION CONDITIONS

Keyfob operation	Operation condition
Door lock operation (locking)	<ul style="list-style-type: none"><li>• With key removed (key switch: OFF)</li><li>• Closing all doors (door switch: OFF)</li></ul>
Door lock operation (unlocking)	With key removed (key switch: OFF)

### AUTO LOCK FUNCTION

#### Operation Description

- Unless the key is inserted into the ignition key cylinder, one of the doors is opened, or the keyfob is operated within 1 minute after a door lock is unlocked by keyfob operation, all the doors are automatically locked. The 1 minute timer count is executed by the BCM and after 1 minute, the BCM sends the lock signal to all doors. Lock operations are the same as for the remote control entry function.

### ACTIVE CHECK FUNCTION

#### Operation Description

- When a door is locked or unlocked by keyfob operation, the vehicle turn signals flash and the horn sounds to verify operation.
- When a button on the keyfob is operated, the signal is sent from the remote controller and received by the keyless remote entry receiver.
  - The received signal is sent to the BCM and compared with the registered ID number.
  - If the ID number matches, the BCM uses communication to send the turn signal flashing and horn signal to the IPDM E/R.
  - The IPDM E/R flashes the turn signal lamps and sounds the horn for each keyfob operation.

A  
B  
C  
D  
E  
F  
G  
H  
I  
J  
L  
M  
N  
O  
P

DLK

# DOOR LOCK FUNCTION

## < SYSTEM DESCRIPTION >

Operating function of hazard and horn reminder

	MODE 1 (C mode)		MODE 2 (S mode)	
	Lock	Unlock	Lock	Unlock
Keyfob operation	Lock	Unlock	Lock	Unlock
Hazard warning lamp flash	Twice	Once	Twice	—
Horn sound	Once	—	—	—

### HAZARD AND HORN REMINDER

BCM output to IPDM E/R for horn reminder signal as DATA LINE (CAN-H line and CAN-L line).

The hazard and horn reminder has C mode (horn chirp mode) and S mode (non-horn chirp mode).

#### How to change hazard and horn reminder mode

##### Ⓟ With CONSULT

Hazard and horn reminder can be changed using "WORK SUPPORT" mode in "MULTI ANSWER BACK SET".

Refer to [BCS-17, "MULTI REMOTE ENT : CONSULT Function \(BCM - MULTI REMOTE ENT\)"](#).

##### ⓧ Without CONSULT

Refer to Owner's Manual for instructions.

### INTERIOR LAMP OPERATION

When the following input signals are both supplied:

- all door switches are in the OFF position. (when all the doors are closed);
- interior lamp switch is in DOOR position.

Remote keyless entry system turns on interior lamp and ignition keyhole illumination (for 30 seconds) with input of UNLOCK signal from keyfob.

### PANIC ALARM OPERATION

When key switch is OFF (when ignition key is not inserted in key cylinder), remote keyless entry system turns on and off horn and headlamp intermittently with input of PANIC ALARM signal from keyfob.

The alarm automatically turns off after 25 seconds or when BCM receives any signal from keyfob.

### KEYLESS POWER WINDOW DOWN (OPEN) OPERATION

When keyfob unlock switch is turned ON with ignition switch OFF, and the switch is detected to be ON continuously for more than 1 second, the driver's door and passenger's door power windows are simultaneously opened.

Power window is operated to open and the operation continues as long as the keyfob unlock switch is pressed.



# DOOR LOCK FUNCTION

< SYSTEM DESCRIPTION >

## REMOTE KEYLESS ENTRY : Component Parts Location - King Cab

INFOID:000000008792252

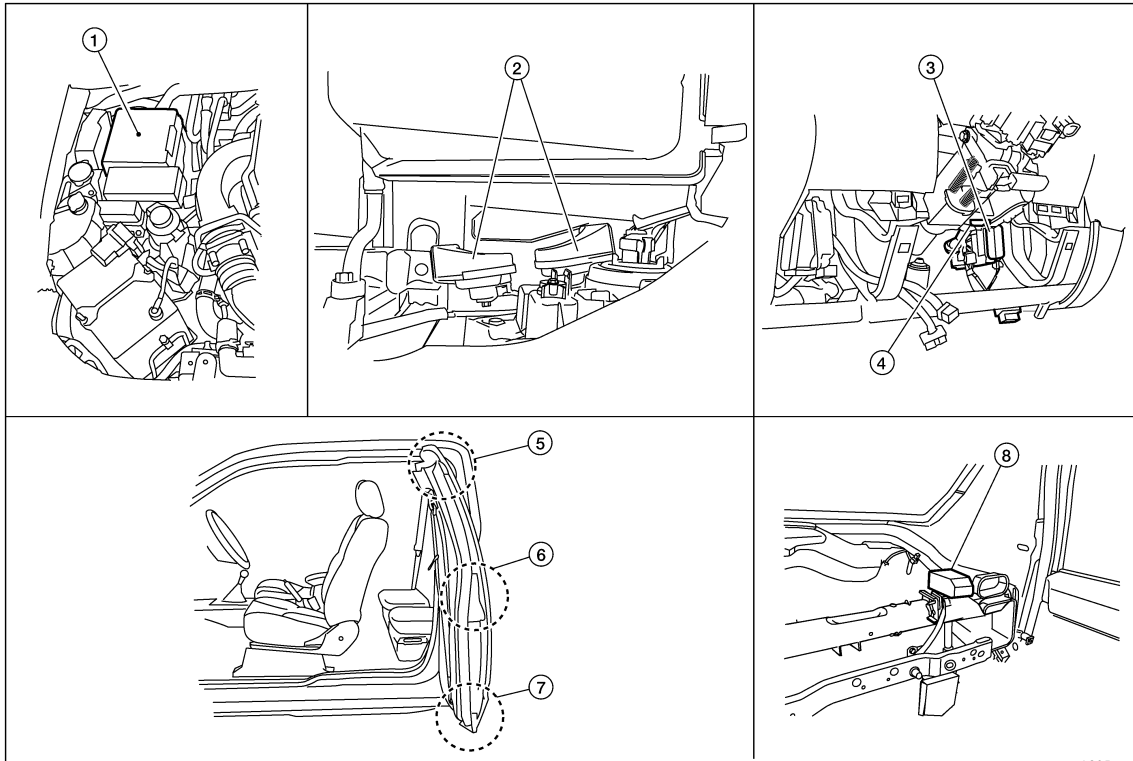

- |   |   |  |
|---|---|--|
| 1. IPDM E/R E122, E124                          | 2. Horns E6 (with dual note horn)<br>E3, E162 (with single note horn)<br>(behind front combination lamp LH) | 3. BCM M18, M19, M20<br>(view with lower instrument panel LH<br>removed) |
| 4. Key switch M27                               | 5. Rear door switch upper<br>LH D211<br>RH D312   | 6. Front door switch<br>LH D213<br>RH D314                               |
| 7. Rear door switch lower<br>LH D212<br>RH D313 | 8. Remote keyless entry receiver M120<br>(view with instrument panel RH re-<br>moved)                       |  |

A  
B  
C  
D  
E  
F  
G  
H  
I  
J  
DLK  
L  
M  
N  
O  
P

# DOOR LOCK FUNCTION

< SYSTEM DESCRIPTION >

## REMOTE KEYLESS ENTRY : Component Parts Location - Crew Cab

INFOID:000000008792253

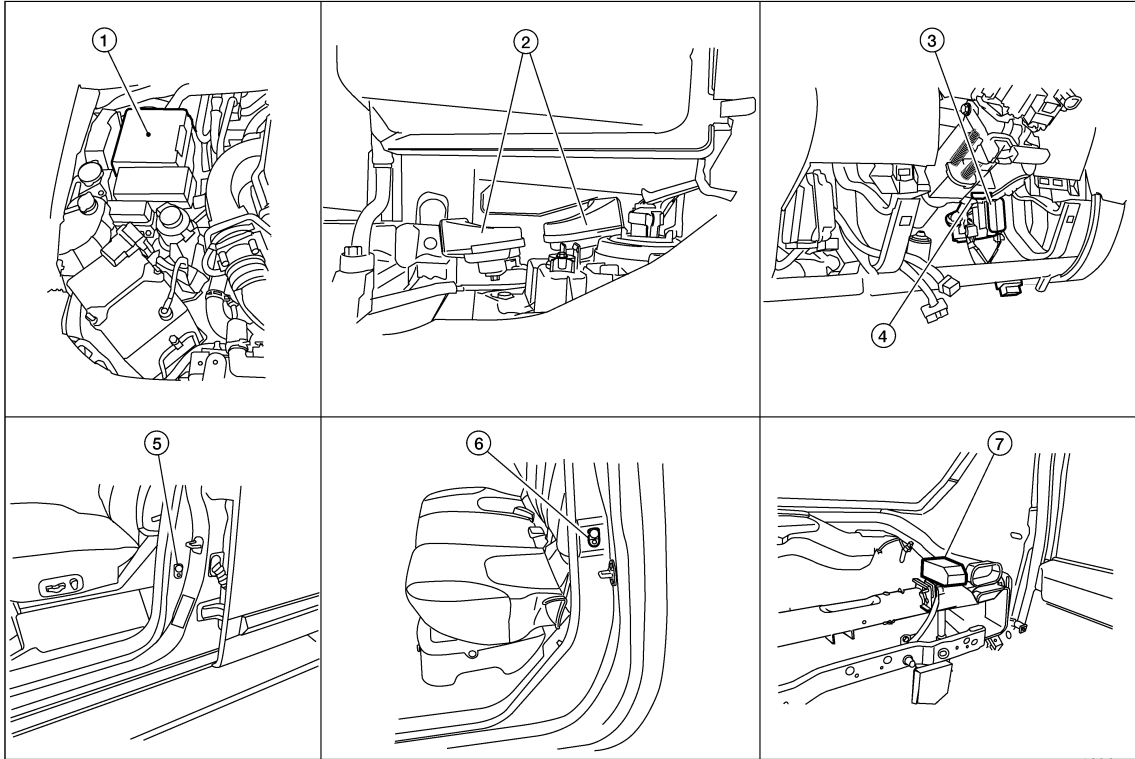

- |  |   |   |
|--|---|---|
| 1. IPDM E/R E122, E124   | 2. Horns E6<br>(behind front combination lamp LH) | 3. BCM M18, M19, M20<br>(view with lower instrument lower panel LH removed) |
| 4. Key switch M27  | 5. Front door switch<br>LH B8<br>RH B108          | 6. Rear door switch<br>LH B18<br>RH B116                                    |
| 7. Remote keyless entry receiver M120<br>(view with instrument panel RH removed) |   |   |

## REMOTE KEYLESS ENTRY : Component Description

INFOID:000000008792254

Item	Function
BCM	Controls the door lock function and room lamp function.
Door lock and unlock switch	Transmits lock or unlock signal to BCM.
Door switch	Transmits door open/close condition to BCM.
Remote keyless entry receiver	Receives lock/unlock signal from the keyfob, and then transmits to BCM.

# HOMELINK UNIVERSAL TRANSCEIVER

< SYSTEM DESCRIPTION >

## HOMELINK UNIVERSAL TRANSCEIVER

### Component Description

INFOID:000000008792255

Item	Function	Reference page
Homelink universal transceiver	A maximum of 3 radio signals can be stored and transmitted to operate the garage door, etc.	Refer to Owner's Manual

A  
B  
C  
D  
E  
F  
G  
H  
I  
J  
DLK  
L  
M  
N  
O  
P

## DIAGNOSIS SYSTEM (BCM)

< SYSTEM DESCRIPTION >

### DIAGNOSIS SYSTEM (BCM)

#### COMMON ITEM

COMMON ITEM : CONSULT Function (BCM - COMMON ITEM)

INFOID:000000009232907

#### APPLICATION ITEM

CONSULT performs the following functions via CAN communication with BCM.

Direct Diagnostic Mode	Description
Ecu Identification	The BCM part number is displayed.
Self Diagnostic Result	The BCM self diagnostic results are displayed.
Data Monitor	The BCM input/output data is displayed in real time.
Active Test	The BCM activates outputs to test components.
Work support	The settings for BCM functions can be changed.
Configuration	<ul style="list-style-type: none"> <li>• The vehicle specification can be read and saved.</li> <li>• The vehicle specification can be written when replacing BCM.</li> </ul>
CAN Diag Support Mntr	The result of transmit/receive diagnosis of CAN communication is displayed.

#### SYSTEM APPLICATION

BCM can perform the following functions.

System	Sub System	Direct Diagnostic Mode						
		Ecu Identification	Self Diagnostic Result	Data Monitor	Active Test	Work support	Configuration	CAN Diag Support Mntr
Door lock	DOOR LOCK			x	x	x		
Rear window defogger	REAR DEFOGGER			x	x			
Warning chime	BUZZER			x	x			
Interior room lamp timer	INT LAMP			x	x	x		
Remote keyless entry system	MULTI REMOTE ENT			x	x	x		
Exterior lamp	HEAD LAMP			x	x	x		
Wiper and washer	WIPER			x	x	x		
Turn signal and hazard warning lamps	FLASHER			x	x			
Air conditioner	AIR CONDITIONER			x				
Combination switch	COMB SW			x				
BCM	BCM	x	x			x	x	x
Immobilizer	IMMU		x	x	x			
Interior room lamp battery saver	BATTERY SAVER			x	x	x		
Vehicle security system	THEFT ALM			x	x	x		
RAP system	RETAINED PWR			x	x	x		
Signal buffer system	SIGNAL BUFFER			x	x			
TPMS	AIR PRESSURE MONITOR		x	x	x	x		
Panic alarm system	PANIC ALARM				x			

### DOOR LOCK

# DIAGNOSIS SYSTEM (BCM)

< SYSTEM DESCRIPTION >

## DOOR LOCK : CONSULT Function (BCM - DOOR LOCK)

INFOID:000000009232908

### DATA MONITOR

Monitor Item [Unit]	Description
IGN ON SW [On/Off]	Indicates condition of ignition switch ON position.
KEY ON SW [On/Off]	Indicates condition of key switch.
CDL LOCK SW [On/Off]	Indicates condition of lock signal from door lock and unlock switch.
CDL UNLOCK SW [On/Off]	Indicates condition of unlock signal from door lock and unlock switch.
DOOR SW-DR [On/Off]	Indicates condition of front door switch LH.
DOOR SW-AS [On/Off]	Indicates condition of front door switch RH.
DOOR SW-RR [On/Off]	Indicates condition of rear door switch RH.
DOOR SW-RL [On/Off]	Indicates condition of rear door switch LH.
KEY CYL LK-SW [On/Off]	Indicates condition of lock signal from door key cylinder switch.
KEY CYL UN-SW [On/Off]	Indicates condition of unlock signal from door key cylinder switch.
KEYLESS LOCK [On/Off]	Indicates condition of lock signal from keyfob.
KEYLESS UNLOCK [On/Off]	Indicates condition of unlock signal from keyfob.

### ACTIVE TEST

Test Item	Description
DOOR LOCK	This test is able to check door lock operation [OTR ULK/DR UNLK/ALL ULK/ALL LCK].

### WORK SUPPORT

Support Item	Setting	Description
DOOR LOCK-UNLOCK SET	On*	Automatic door locks function ON.
	Off	Automatic door locks function OFF.
ANTI-LOCK OUT SET	Off	Anti lock out function OFF.
	On*	Anti lock out function ON.
AUTOMATIC DOOR LOCK SELECT	SHIFT OUT OF P	Doors lock automatically when shifted out of park (P).
	VH SPD*	Doors lock automatically when vehicle speed reaches 24 km/h (15 mph).
AUTOMATIC DOOR UNLOCK SELECT	MODE6	Drivers door unlocks automatically when key is removed.
	MODE5	Drivers door unlocks automatically when shifted into park (P).
	MODE4	Drivers door unlocks automatically when ignition is switched from ON to OFF.
	MODE3	Doors unlock automatically when key is removed.
	MODE2*	Doors unlock automatically when shifted into park (P).
AUTOMATIC LOCK/UNLOCK SELECT	On	Automatic lock/unlock function ON.
	Off*	Automatic lock/unlock function OFF.

\* : Initial setting

### MULTI REMOTE ENT

## MULTI REMOTE ENT : CONSULT Function (BCM - MULTI REMOTE ENT)

INFOID:000000009232909

### DATA MONITOR

# DIAGNOSIS SYSTEM (BCM)

## < SYSTEM DESCRIPTION >

Monitor Item [Unit]	Description
IGN ON SW [On/Off]	Indicates condition of ignition switch ON position.
KEY ON SW [On/Off]	Indicates condition of key switch.
ACC ON SW [On/Off]	Indicates condition of ignition switch ACC position.
KEYLESS LOCK [On/Off]	Indicates condition of lock signal from keyfob.
KEYLESS UNLOCK [On/Off]	Indicates condition of unlock signal from keyfob.
KEYLESS PANIC [On/Off]	Indicates condition of panic signal from keyfob.
DOOR SW-DR [On/Off]	Indicates condition of front door switch LH.
DOOR SW-AS [On/Off]	Indicates condition of front door switch RH.
DOOR SW-RR [On/Off]	Indicates condition of rear door switch RH.
DOOR SW-RL [On/Off]	Indicates condition of rear door switch LH.
CDL LOCK SW [On/Off]	Indicates condition of lock signal from door lock and unlock switch.
CDL UNLOCK SW [On/Off]	Indicates condition of unlock signal from door lock and unlock switch.
KEY CYL LK SW [On/Off]	Indicates condition of lock signal from door key cylinder switch.

## ACTIVE TEST

Test Item	Description
DOOR LOCK	This test is able to check door lock operation [OTR ULK/DR UNLK/ALL ULK/ALL LCK].
FLASHER	This test is able to check hazard reminder operation [Off/LH/RH].
HORN	This test is able to check horn operation [On].

## WORK SUPPORT

Support Item	Setting	Description	
HORN CHIRP SET	Off	Horn chirp function can be changed in this mode.	
	On*		
HAZARD LAMP SET	MODE4*	Lock and Unlock	Hazard warning lamp function can be changed in this mode.
	MODE3	Lock Only	
	MODE2	Unlock Only	
	MODE1	OFF	
MULTI ANSWER BACK SET	MODE2*	Lock	Hazard warning lamps flash twice and horn does not sound.
		Unlock	Hazard warning lamps do not flash and horn does not sound.
	MODE1	Lock	Hazard warning lamps flash twice and horn sounds once.
		Unlock	Hazard warning lamps flash once and horn does not sound.
AUTO LOCK SET	MODE3	1 min	Auto locking function can be changed in this mode.
	MODE2	OFF	
	MODE1*	5 min	
PANIC ALRM SET	MODE3	1.5 sec	Panic alarm operation can be changed in this mode.
	MODE2	OFF	
	MODE1*	0.5 sec	
REMO CONT ID REGIST	—	Keyfob ID code can be registered.	
REMO CONT ID ERASUR	—	Keyfob ID code can be erased.	
REMO CONT ID CONFIR	—	Keyfob ID code registration is displayed.	

\*: Initial setting

# U1000 CAN COMM CIRCUIT

< DTC/CIRCUIT DIAGNOSIS >

## DTC/CIRCUIT DIAGNOSIS

### U1000 CAN COMM CIRCUIT

#### Description

INFOID:000000009232910

Refer to [LAN-58, "CAN Communication Signal Chart"](#).

#### DTC Logic

INFOID:000000009232911

#### DTC DETECTION LOGIC

DTC	CONSULT display description	DTC Detection Condition	Possible cause
U1000	CAN COMM CIRCUIT	When BCM cannot communicate CAN communication signal continuously for 2 seconds or more.	Any item (or items) of the following listed below is malfunctioning in CAN communication system. <ul style="list-style-type: none"><li>• Transmission</li><li>• Receiving (ECM)</li><li>• Receiving (METER/M&amp;A)</li><li>• Receiving (TCM)</li><li>• Receiving (IPDM E/R)</li></ul>

#### Diagnosis Procedure

INFOID:000000009232912

#### 1. PERFORM SELF DIAGNOSTIC

1. Turn ignition switch ON and wait for 2 seconds or more.
2. Check "Self Diagnostic Result" of BCM.

Is "CAN COMM CIRCUIT" displayed?

- YES >> Refer to [LAN-14, "Trouble Diagnosis Flow Chart"](#).  
NO >> Refer to [GI-49, "Intermittent Incident"](#).

A  
B  
C  
D  
E  
F  
G  
H  
I  
J  
L  
M  
N  
O  
P

DLK

# U1010 CONTROL UNIT (CAN)

< DTC/CIRCUIT DIAGNOSIS >

## U1010 CONTROL UNIT (CAN)

### DTC Logic

INFOID:000000008792262

### DTC DETECTION LOGIC

DTC	CONSULT display description	DTC Detection Condition	Possible cause
U1010	CONTROL UNIT (CAN)	BCM detected internal CAN communication circuit malfunction.	BCM

### Diagnosis Procedure

INFOID:000000008792263

#### 1.REPLACE BCM

When DTC [U1010] is detected, replace BCM.

>> Replace BCM. Refer to [BCS-49. "Removal and Installation"](#).

### Special Repair Requirement

INFOID:000000008792264

#### 1.REQUIRED WORK WHEN REPLACING BCM

The BCM must be initialized when replaced. Refer to (Body Control System) for BCM configuration. Initialize NVIS by CONSULT. For the details of initialization refer to CONSULT Immobilizer mode and follow the on-screen instructions.

>> Inspection End.



# POWER SUPPLY AND GROUND CIRCUIT

< DTC/CIRCUIT DIAGNOSIS >

## POWER SUPPLY AND GROUND CIRCUIT

### Diagnosis Procedure

INFOID:00000009232913

Regarding Wiring Diagram information, refer to [BCS-43. "Wiring Diagram"](#).

### 1. CHECK FUSES AND FUSIBLE LINK

Check that the following fuses and fusible link are not blown.

Terminal No.	Signal name	Fuses and fusible link No.
57	Battery power supply	21 (10A)
70		G (50A)
11	Ignition ACC or ON	4 (10A)
38	Ignition ON or START	1 (10A)

Is the fuse blown?

YES >> Replace the blown fuse or fusible link after repairing the affected circuit.

NO >> GO TO 2

### 2. CHECK POWER SUPPLY CIRCUIT

1. Turn ignition switch OFF.
2. Disconnect BCM.
3. Check voltage between BCM harness connector and ground.

Connector	Terminals		Power source	Condition	Voltage (V) (Approx.)
	(+)	(-)			
M18	11	Ground	ACC power supply	Ignition switch ACC or ON	Battery voltage
	38	Ground	Ignition power supply	Ignition switch ON or START	Battery voltage
M20	57	Ground	Battery power supply	Ignition switch OFF	Battery voltage
	70	Ground	Battery power supply	Ignition switch OFF	Battery voltage

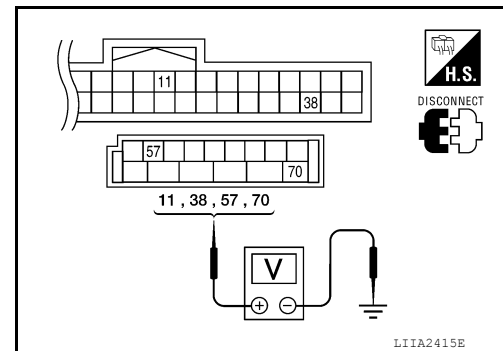

Is the measurement value normal?

YES >> GO TO 3

NO >> Repair or replace harness.

### 3. CHECK GROUND CIRCUIT

A  
B  
C  
D  
E  
F  
G  
H  
I  
J  
DLK  
L  
M  
N  
O  
P

# POWER SUPPLY AND GROUND CIRCUIT

## < DTC/CIRCUIT DIAGNOSIS >

Check continuity between BCM harness connector and ground.

BCM		Ground	Continuity
Connector	Terminal		
M20	67		Yes

### Does continuity exist?

- YES >> Inspection End.
- NO >> Repair or replace harness.

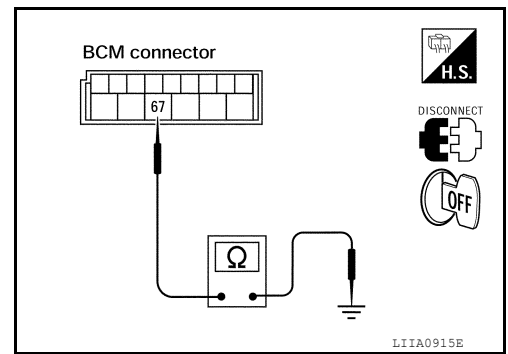

# DOOR SWITCH

< DTC/CIRCUIT DIAGNOSIS >

## DOOR SWITCH

### KING CAB

#### KING CAB : Description

INFOID:000000008792266

Detects door open/close condition.

#### KING CAB : Component Function Check

INFOID:000000008792267

### 1.CHECK FUNCTION

#### With CONSULT

Check door switches in Data Monitor mode with CONSULT.

Monitor item	Condition
DOOR SW-DR	CLOSE → OPEN: OFF → ON
DOOR SW-AS	

Is the inspection result normal?

YES >> Door switch is OK.

NO >> Refer to [DLK-27. "KING CAB : Diagnosis Procedure"](#).

#### KING CAB : Diagnosis Procedure

INFOID:000000008792268

Regarding Wiring Diagram information, refer to [DLK-77. "Wiring Diagram - King Cab"](#).

### 1.CHECK DOOR SWITCHES INPUT SIGNAL

#### With CONSULT

Check door switches ("DOOR SW-DR", "DOOR SW-AS") in DATA MONITOR mode with CONSULT. Refer to [BCS-15. "DOOR LOCK : CONSULT Function \(BCM - DOOR LOCK\)"](#).

• When any doors are open:

**DOOR SW-DR :ON**

**DOOR SW-AS :ON**

• When any doors are closed:

**DOOR SW-DR :OFF**

**DOOR SW-AS :OFF**

#### Without CONSULT

Check voltage between BCM connector M18 or M19 terminals 12, 47 and ground.

Connector	Item	Terminals		Condition	Voltage (V) (Approx.)
		(+)	(-)		
M19	Door switches LH	47	Ground	Open	0
M18	Door switches RH	12		Closed	Battery voltage

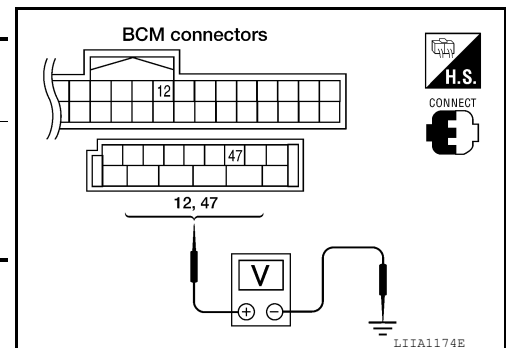

Is the inspection result normal?

YES >> Door switch circuit is OK.

NO >> GO TO 2

### 2.CHECK BCM OUTPUT VOLTAGE

# DOOR SWITCH

## < DTC/CIRCUIT DIAGNOSIS >

1. Turn ignition switch OFF.
2. Disconnect door switches.
3. Check voltage between BCM connector M18, M19 terminals 12, 47 and ground.

**12 - Ground : Battery voltage**  
**47 - Ground : Battery voltage**

Is the inspection result normal?

- YES >> GO TO 3  
 NO >> Replace BCM. Refer to [BCS-49, "Removal and Installation"](#).

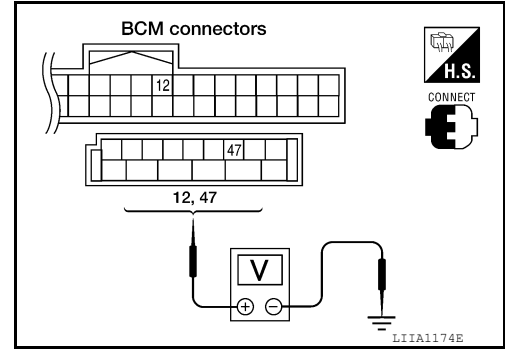

## 3. CHECK DOOR SWITCH CIRCUIT

1. Disconnect BCM.
2. Check continuity between door switch connector D213 (Front LH), D314 (Front RH) terminal 2, D211 (Rear upper LH), D312 (Rear upper RH), D212 (Rear lower LH), D313 (Rear lower RH) terminal 1 and BCM connector M18, M19 terminals 12, and 47.

**2 - 47 : Continuity should exist**  
**2 - 12 : Continuity should exist**  
**1 - 47 : Continuity should exist**  
**1 - 12 : Continuity should exist**

3. Check continuity between door switch connector D213 (Front LH), D314 (Front RH) terminal 2, D211 (Rear upper LH), D312 (Rear upper RH), D212 (Rear lower LH), D313 (Rear lower RH) terminal 1 and ground.

**2 - Ground : Continuity should not exist**  
**1 - Ground : Continuity should not exist**

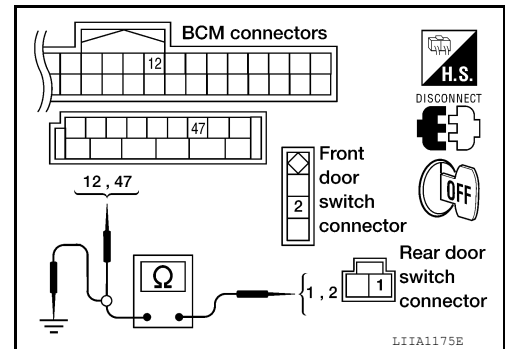

Is the inspection result normal?

- YES >> GO TO 4  
 NO >> Repair or replace harness.

## 4. CHECK DOOR SWITCHES GROUND CIRCUIT

Check continuity between door switch connector D213 (Front LH), D314 (Front RH) terminal 3, D211 (Rear upper LH), D312 (Rear upper RH), D212 (Rear lower LH), D313 (Rear lower RH) terminal 2 and ground.

**3 - Ground : Continuity should exist**  
**2 - Ground : Continuity should exist**

Is the inspection result normal?

- YES >> GO TO 5  
 NO >> Repair or replace harness.

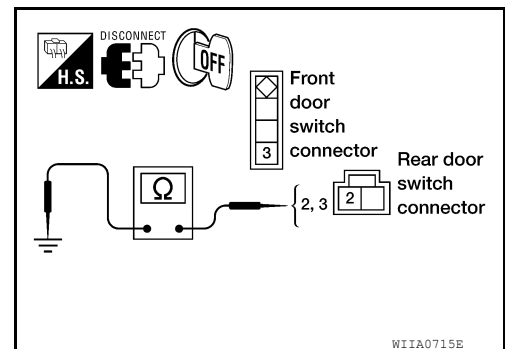

## 5. CHECK DOOR SWITCHES

Check continuity between door switch terminals.

# DOOR SWITCH

## < DTC/CIRCUIT DIAGNOSIS >

Item	Terminal	Condition	Continuity
Door switches (front)	2 - 3	Open	Yes
		Closed	No
Door switches (rear upper and lower)	1 - 2	Open	Yes
		Closed	No

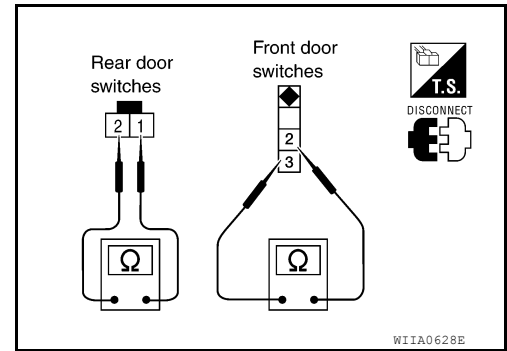

### Is the inspection result normal?

- YES >> Check condition of harness and connector.
- NO >> Replace door switch.

## CREW CAB

### CREW CAB : Description

INFOID:000000008792269

Detects door open/close condition.

### CREW CAB : Component Function Check

INFOID:000000008792270

## 1. CHECK FUNCTION

### With CONSULT

Check door switches in Data Monitor mode with CONSULT.

Monitor item	Condition
DOOR SW-DR	CLOSE → OPEN: OFF → ON
DOOR SW-AS	
DOOR SW-RL	
DOOR SW-RR	

### Is the inspection result normal?

- YES >> Door switch is OK.
- NO >> Refer to [DLK-29. "CREW CAB : Diagnosis Procedure"](#).

## CREW CAB : Diagnosis Procedure

INFOID:000000008792271

Regarding Wiring Diagram information, refer to [DLK-87. "Wiring Diagram - Crew Cab"](#).

## 1. CHECK DOOR SWITCHES INPUT SIGNAL

### With CONSULT

Check door switches ("DOOR SW-DR", "DOOR SW-AS", "DOOR SW-RL", "DOOR SW-RR") in DATA MONITOR mode with CONSULT. Refer to [BCS-15. "DOOR LOCK : CONSULT Function \(BCM - DOOR LOCK\)"](#).

• When any doors are open:

**DOOR SW-DR : ON**  
**DOOR SW-AS : ON**  
**DOOR SW-RL : ON**  
**DOOR SW-RR : ON**

• When any doors are closed:

**DOOR SW-DR : OFF**  
**DOOR SW-AS : OFF**  
**DOOR SW-RL : OFF**  
**DOOR SW-RR : OFF**

# DOOR SWITCH

## < DTC/CIRCUIT DIAGNOSIS >

Without CONSULT

Check voltage between BCM connector M18 or M19 terminals 12, 13, 47, 48 and ground.

Connector	Item	Terminals		Condition	Voltage (V) (Approx.)
		(+)	(-)		
M19	Front door switch LH	47	Ground	Open ↓ Closed	0 ↓ Battery voltage
	Rear door switch LH	48			
M18	Front door switch RH	12			
	Rear door switch RH	13			

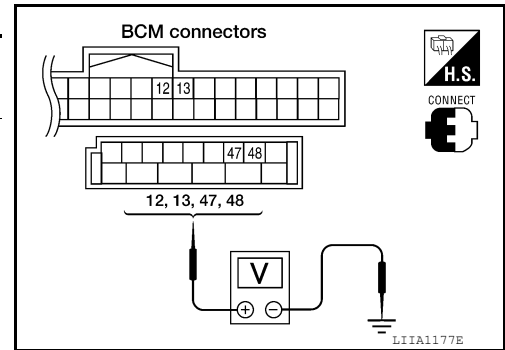

Is the inspection result normal?

- YES >> Door switch circuit is OK.
- NO >> GO TO 2

## 2. CHECK BCM OUTPUT VOLTAGE

1. Turn ignition switch OFF.
2. Disconnect door switches.
3. Check voltage between BCM connector M18, M19 terminals 12, 13, 47, 48 and ground.

- 12 - Ground : Battery voltage**
- 13 - Ground : Battery voltage**
- 47 - Ground : Battery voltage**
- 48 - Ground : Battery voltage**

Is the inspection result normal?

- YES >> GO TO 3
- NO >> Replace BCM. Refer to [BCS-49, "Removal and Installation"](#).

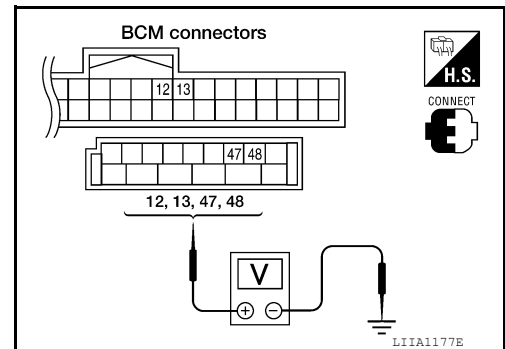

## 3. CHECK DOOR SWITCH CIRCUIT

1. Disconnect door switch and BCM.
2. Check continuity between door switch connector B8 (Front LH), B108 (Front RH), B18 (Rear LH), B116 (Rear RH) terminal 2 and BCM connector M18, M19 terminals 12, 13, 47 and 48.

- 2 - 47 : Continuity should exist.**
- 2 - 12 : Continuity should exist.**
- 2 - 48 : Continuity should exist.**
- 2 - 13 : Continuity should exist.**

3. Check continuity between door switch connector B8 (Front LH), B108 (Front RH), B18 (Rear LH), B116 (Rear RH) terminal 2 and ground.

- 2 - Ground : Continuity should not exist.**

Is the inspection result normal?

- YES >> GO TO 4
- NO >> Repair or replace harness.

## 4. CHECK DOOR SWITCHES

1. Disconnect door switch.
2. Check continuity between door switch terminals.

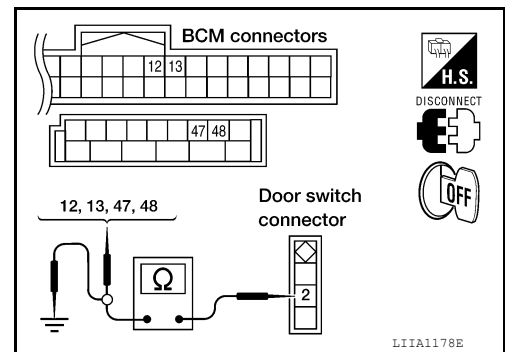

# DOOR SWITCH

## < DTC/CIRCUIT DIAGNOSIS >

	Terminal	Condition	Continuity
Door switch	2 – Ground	Open	Yes
		Closed	No

### Is the inspection result normal?

YES >> Check switch case ground condition.

NO >> Replace door switch.

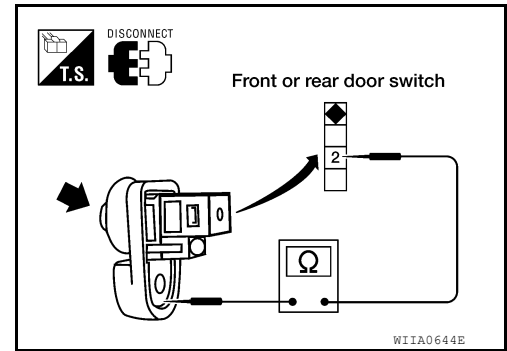

A  
B  
C  
D  
E  
F  
G  
H  
I  
J  
L  
M  
N  
O  
P

DLK

# DOOR LOCK AND UNLOCK SWITCH

< DTC/CIRCUIT DIAGNOSIS >

## DOOR LOCK AND UNLOCK SWITCH KING CAB

### KING CAB : Description

INFOID:000000008792272

Transmits door lock/unlock operation to BCM.

### KING CAB : Component Function Check

INFOID:000000008792273

## 1. CHECK FUNCTION

### With CONSULT

Check CDL LOCK SW, CDL UNLOCK SW in Data Monitor mode with CONSULT.

Monitor item	Condition
CDL LOCK SW	LOCK : ON
	UNLOCK : OFF
CDL UNLOCK SW	LOCK : OFF
	UNLOCK : ON

Is the inspection result normal?

- YES >> Door lock and unlock switch is OK.
- NO >> refer to [DLK-32, "KING CAB : Diagnosis Procedure"](#).

### KING CAB : Diagnosis Procedure

INFOID:000000009241304

Regarding Wiring Diagram information, refer to [DLK-77, "Wiring Diagram - King Cab"](#).

## 1. CHECK DOOR LOCK/UNLOCK SWITCH INPUT SIGNAL

### With CONSULT

Check door lock/unlock switch ("CDL LOCK SW", "CDL UNLOCK SW") in DATA MONITOR mode in CONSULT-III. Refer to [DLK-21, "DOOR LOCK : CONSULT Function \(BCM - DOOR LOCK\)"](#).

- When door lock/unlock switch is turned to LOCK:

**CDL LOCK SW : ON**

- When door lock/unlock switch is turned to UNLOCK:

**CDL UNLOCK SW : ON**

### Without CONSULT

Check voltage between BCM connector M19 terminals 45, 46 and ground.

Connector	Terminals		Condition	Voltage (V) (Approx.)
	(+)	(-)		
M19	46	Ground	Door lock/unlock switch is neutral.	Battery voltage
			Door lock/unlock switch is turned to UNLOCK.	0
	45	Ground	Door lock/unlock switch is neutral.	Battery voltage
			Door lock/unlock switch is turned to LOCK.	0

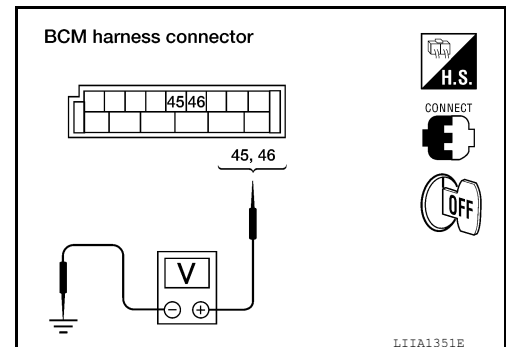

Is the inspection result normal?



# DOOR LOCK AND UNLOCK SWITCH

## < DTC/CIRCUIT DIAGNOSIS >

- YES >> Door lock/unlock switch circuit is OK.
- NO >> GO TO 2

## 2.CHECK DOOR LOCK/UNLOCK SWITCH

1. Turn ignition switch OFF.
2. Disconnect door lock/unlock switch.
3. Check continuity between main power window and door lock/unlock switch terminals 10, 11 and 14.

Terminal	Condition	Continuity
10	Lock	Yes
	Unlock/Neutral	No
11	Unlock	Yes
	Lock/Neutral	No

4. Check continuity between power window and door lock/unlock switch RH terminals 1, 2 and 3.

Terminal	Condition	Continuity
1	Lock	Yes
	Unlock/Neutral	No
2	Unlock	Yes
	Lock/Neutral	No

Is the inspection result normal?

- YES >> GO TO 3
- NO >> Replace door lock/unlock switch.

## 3.CHECK DOOR LOCK/UNLOCK SWITCH GROUND HARNESS

1. Disconnect main power window and door lock/unlock switch or power window and door lock/unlock switch RH.
2. Check continuity between main power window and door lock/unlock switch connector D7 terminal 14 and ground.

**14 - Ground : Continuity should exist.**

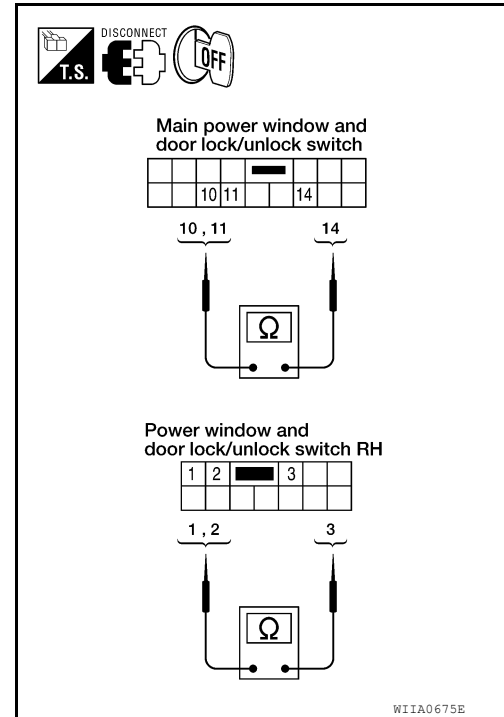

3. Check continuity between power window and door lock/unlock switch RH connector D105 terminal 3 and ground

**3 - Ground : Continuity should exist.**

Is the inspection result normal?

- YES >> GO TO 4
- NO >> Repair or replace harness.

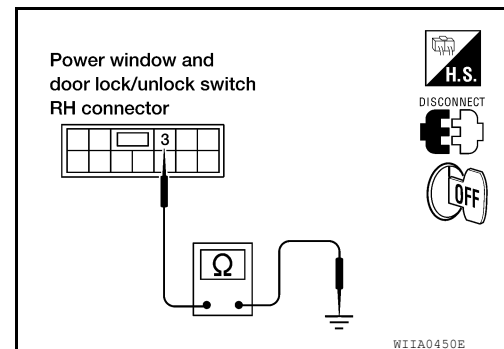
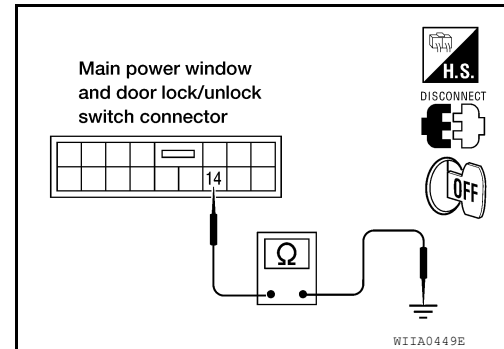

## 4.CHECK DOOR LOCK SWITCH CIRCUIT

1. Disconnect BCM.

A  
B  
C  
D  
E  
F  
G  
H  
I  
J  
K  
L  
M  
N  
O  
P

DLK

# DOOR LOCK AND UNLOCK SWITCH

## < DTC/CIRCUIT DIAGNOSIS >

- Check continuity between BCM connector M19 terminal 45 and main power window and door lock/unlock switch connector D7 terminal 10 or power window and door lock/unlock switch RH connector D105 terminal 1.

**1 - 45** : Continuity should exist.

**10 - 45** : Continuity should exist.

- Check continuity between BCM connector M19 terminal 45 and ground.

**45 - Ground** : Continuity should not exist.

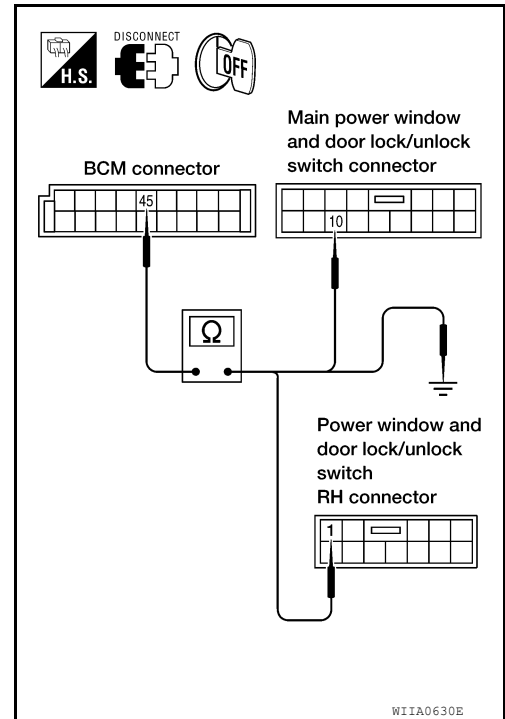

- Check continuity between BCM connector M19 terminal 46 and main power window and door lock/unlock switch LH connector D7 terminal 11 or power window and door lock/unlock switch RH connector D105 terminal 2.

**2 - 46** : Continuity should exist.

**11 - 46** : Continuity should exist.

- Check continuity between BCM connector M19 terminal 46 and ground.

**46 - Ground** : Continuity should not exist.

Is the inspection result normal?

YES >> GO TO 5

NO >> Repair or replace harness.

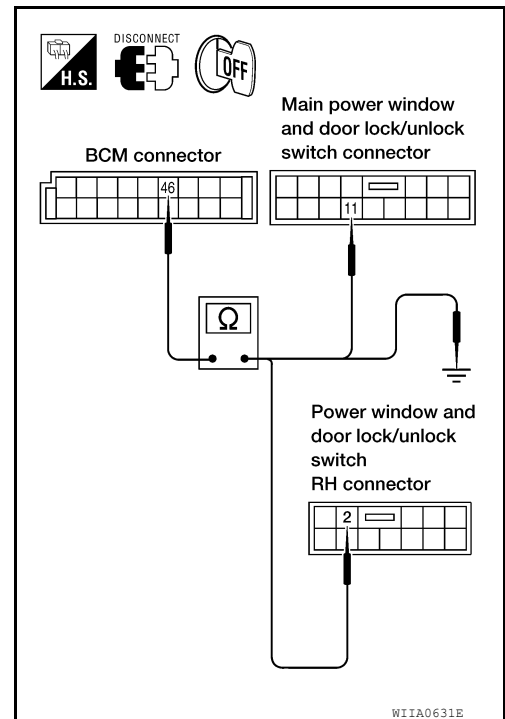

## 5. CHECK BCM OUTPUT VOLTAGE

- Connect BCM.

# DOOR LOCK AND UNLOCK SWITCH

## < DTC/CIRCUIT DIAGNOSIS >

- Check voltage between BCM connector M19 terminals 45, 46 and ground.

**45 - Ground : Battery voltage**  
**46 - Ground : Battery voltage**

Is the inspection result normal?

- YES >> Check condition of the harness and connector.  
 NO >> Replace BCM. Refer to [BCS-49. "Removal and Installation"](#).

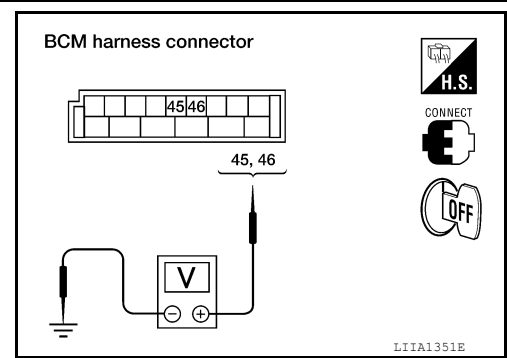

## CREW CAB

### CREW CAB : Description

Transmits door lock/unlock operation to BCM.

### CREW CAB : Component Function Check

#### 1. CHECK FUNCTION

##### With CONSULT

Check CDL LOCK SW, CDL UNLOCK SW in Data Monitor mode with CONSULT.

Monitor item	Condition
CDL LOCK SW	LOCK : ON
	UNLOCK : OFF
CDL UNLOCK SW	LOCK : OFF
	UNLOCK : ON

Is the inspection result normal?

- YES >> Door lock and unlock switch is OK.  
 NO >> Refer to [DLK-35. "CREW CAB : Diagnosis Procedure"](#).

### CREW CAB : Diagnosis Procedure

Regarding Wiring Diagram information, refer to [DLK-87. "Wiring Diagram - Crew Cab"](#).

#### 1. CHECK DOOR LOCK/UNLOCK SWITCH INPUT SIGNAL

##### With CONSULT

Check door lock/unlock switch ("CDL LOCK SW", "CDL UNLOCK SW") in DATA MONITOR mode in CONSULT. Refer to [BCS-15. "DOOR LOCK : CONSULT Function \(BCM - DOOR LOCK\)"](#).

- When door lock/unlock switch is turned to LOCK:

**CDL LOCK SW : ON**

- When door lock/unlock switch is turned to UNLOCK:

**CDL UNLOCK SW : ON**

##### Without CONSULT

Check voltage between BCM connector M19 terminals 45, 46 and ground.

A  
B  
C  
D  
E  
F  
G  
H  
I  
J  
L  
M  
N  
O  
P

DLK

# DOOR LOCK AND UNLOCK SWITCH

## < DTC/CIRCUIT DIAGNOSIS >

Connector	Terminals		Condition	Voltage (V) (Approx.)
	(+)	(-)		
M19	46	Ground	Door lock/unlock switch is neutral.	Battery voltage
			Door lock/unlock switch is turned to UNLOCK.	0
	45	Ground	Door lock/unlock switch is neutral.	Battery voltage
			Door lock/unlock switch is turned to LOCK.	0

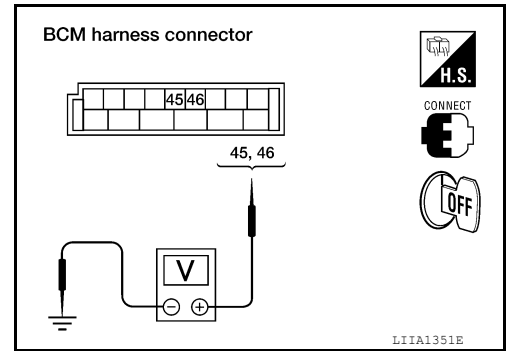

Is the inspection result normal?

YES >> Door lock/unlock switch circuit is OK.

NO >> GO TO 2

## 2. CHECK DOOR LOCK/UNLOCK SWITCH

1. Turn ignition switch OFF.
2. Disconnect door lock/unlock switch.
3. Check continuity between main power window and door lock/unlock switch terminals 10, 11 and 14.

Terminal	Condition	Continuity
10	Lock	Yes
	Unlock/Neutral	No
11	Unlock	Yes
	Lock/Neutral	No

4. Check continuity between power window and door lock/unlock switch RH terminals 1, 2 and 3.

Terminal	Condition	Continuity
1	Lock	Yes
	Unlock/Neutral	No
2	Unlock	Yes
	Lock/Neutral	No

Is the inspection result normal?

YES >> GO TO 3

NO >> Replace door lock/unlock switch.

## 3. CHECK DOOR LOCK/UNLOCK SWITCH GROUND HARNESS

1. Disconnect main power window and door lock/unlock switch or power window and door lock/unlock switch RH.
2. Check continuity between main power window and door lock/unlock switch connector D7 terminal 14 and ground.

**14 - Ground**

**: Continuity should exist.**

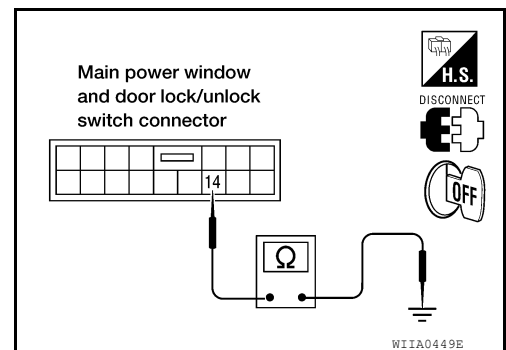
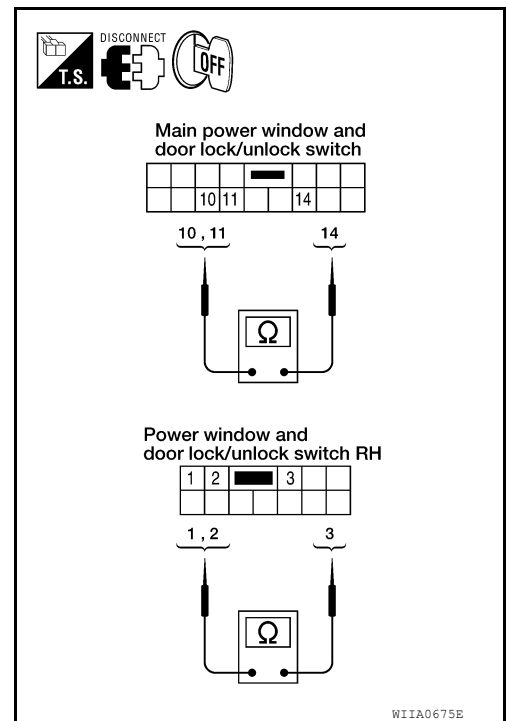

# DOOR LOCK AND UNLOCK SWITCH

## < DTC/CIRCUIT DIAGNOSIS >

3. Check continuity between power window and door lock/unlock switch RH connector D105 terminal 3 and ground

**3 - Ground : Continuity should exist.**

Is the inspection result normal?

- YES >> GO TO 4  
 NO >> Repair or replace harness.

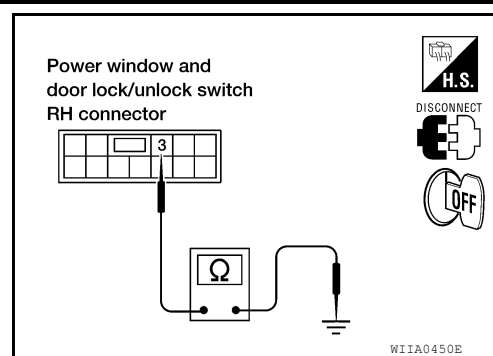

## 4. CHECK DOOR LOCK SWITCH CIRCUIT

1. Disconnect BCM.
2. Check continuity between BCM connector M19 terminal 45 and main power window and door lock/unlock switch connector D7 terminal 10 or power window and door lock/unlock switch RH connector D105 terminal 1.

**1 - 45 : Continuity should exist.**

**10 - 45 : Continuity should exist.**

3. Check continuity between BCM connector M19 terminal 45 and ground.

**45 - Ground : Continuity should not exist.**

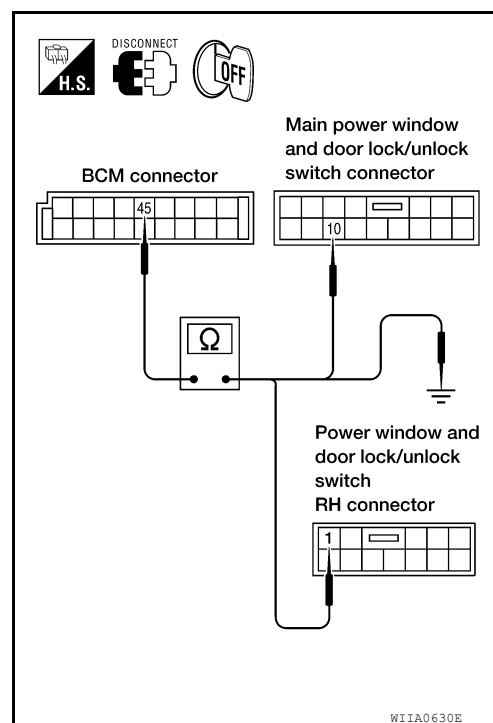

4. Check continuity between BCM connector M19 terminal 46 and main power window and door lock/unlock switch LH connector D7 terminal 11 or power window and door lock/unlock switch RH connector D105 terminal 2.

A  
B  
C  
D  
E  
F  
G  
H  
I  
J  
DLK  
L  
M  
N  
O  
P

# DOOR LOCK AND UNLOCK SWITCH

## < DTC/CIRCUIT DIAGNOSIS >

- 2 - 46 : Continuity should exist.**
- 11 - 46 : Continuity should exist.**

5. Check continuity between BCM connector M19 terminal 46 and ground.

- 46 - Ground : Continuity should not exist.**

Is the inspection result normal?

- YES >> GO TO 5
- NO >> Repair or replace harness.

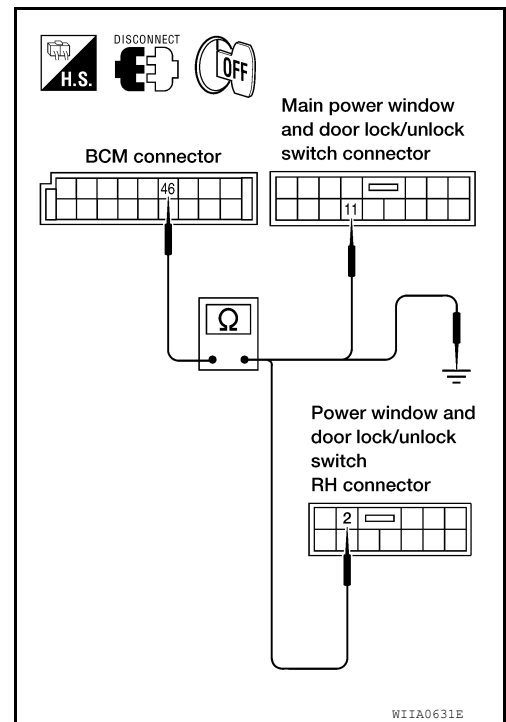

## 5. CHECK BCM OUTPUT VOLTAGE

1. Connect BCM.
2. Check voltage between BCM connector M19 terminals 45, 46 and ground.

- 45 - Ground : Battery voltage**
- 46 - Ground : Battery voltage**

Is the inspection result normal?

- YES >> Check condition of the harness and connector.
- NO >> Replace BCM. Refer to [BCS-49, "Removal and Installation"](#).

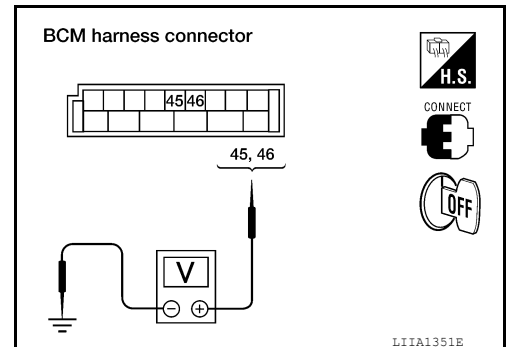

# KEY CYLINDER SWITCH

< DTC/CIRCUIT DIAGNOSIS >

## KEY CYLINDER SWITCH

### DRIVER SIDE

#### DRIVER SIDE : Description

INFOID:000000008792278

The main power window and door lock/unlock switch detects condition of the door key cylinder switch and transmits to BCM as the LOCK or UNLOCK signal.

#### DRIVER SIDE : Component Function Check

INFOID:000000008792279

### 1.CHECK DOOR KEY CYLINDER SWITCH INPUT SIGNAL

Check "KEY CYL LK-SW" AND "KEY CYL UN-SW" in Data Monitor mode for "DOOR LOCK" with CONSULT.

Monitor item	Condition
KEY CYL LK-SW	Lock : ON
	Neutral / Unlock : OFF
KEY CYL UN-SW	Unlock : ON
	Neutral / Lock : OFF

Is the inspection result normal?

YES >> Key cylinder switch is OK.

NO >> Refer to [DLK-39, "DRIVER SIDE : Diagnosis Procedure"](#).

#### DRIVER SIDE : Diagnosis Procedure

INFOID:000000008792280

Regarding Wiring Diagram information, refer to [DLK-77, "Wiring Diagram - King Cab"](#) or [DLK-87, "Wiring Diagram - Crew Cab"](#).

### 1.CHECK DOOR KEY CYLINDER SWITCH LH

Ⓜ With CONSULT

Check front door lock assembly LH (key cylinder switch) ("KEY CYL LK-SW") and ("KEY CYL UN-SW) in DATA MONITOR mode in CONSULT. Refer to [BCS-15, "DOOR LOCK : CONSULT Function \(BCM - DOOR LOCK\)"](#).

- When key inserted in front key cylinder is turned to LOCK:

**KEY CYL LK-SW : ON**

- When key inserted in front key cylinder is turned to UNLOCK:

**KEY CYL UN-SW : ON**

ⓧ Without CONSULT

Check voltage between BCM connector M18 terminals 7, 8 and ground.

Connector	Terminals		Condition	Voltage (V) (Approx.)
	(+)	(-)		
M18	7	Ground	Neutral/Lock	5
			Unlock	0
	8		Neutral/Unlock	5
			Lock	0

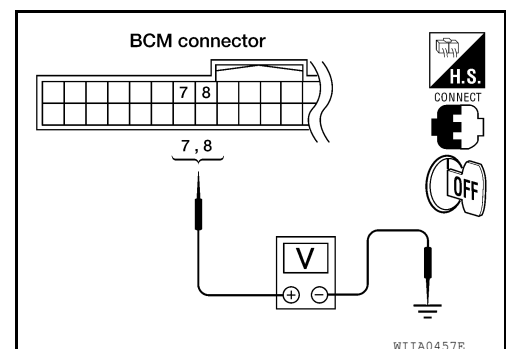

A  
B  
C  
D  
E  
F  
G  
H  
I  
J  
L  
M  
N  
O  
P

DLK

# KEY CYLINDER SWITCH

## < DTC/CIRCUIT DIAGNOSIS >

### Is the inspection result normal?

- YES >> Front door lock assembly LH (key cylinder switch) signal is OK.
- NO >> GO TO 2

## 2. CHECK FRONT DOOR LOCK ASSEMBLY LH (KEY CYLINDER SWITCH)

1. Turn ignition switch OFF.
2. Disconnect front door lock assembly LH (key cylinder switch).
3. Check continuity between front door lock assembly LH (key cylinder switch) connector terminals 3, 4 and 5.

Terminals	Condition	Continuity
4 - 5	Key is turned to LOCK.	Yes
	Key is in N position or turned to UNLOCK	No
3 - 4	Key is turned to UNLOCK.	Yes
	Key is in N position or turned to LOCK	No

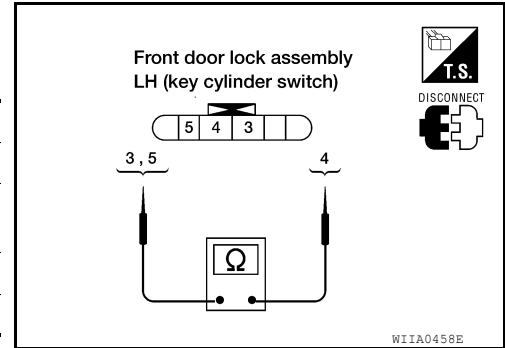

### Is the inspection result normal?

- YES >> GO TO 3
- NO >> Replace front door lock assembly LH (key cylinder switch). Refer to [DLK-136, "Removal and Installation"](#).

## 3. CHECK FRONT DOOR LOCK ASSEMBLY LH HARNESS

1. Disconnect BCM.
2. Check continuity between BCM connector M18 terminals 7, 8 and front door lock assembly LH connector D14 terminals 3, 5.

**7 - 3 : Continuity should exist.**

**8 - 5 : Continuity should exist.**

3. Check continuity between BCM connector M18 terminals 7, 8 and ground.

**7 - Ground : Continuity should not exist.**

**8 - Ground : Continuity should not exist.**

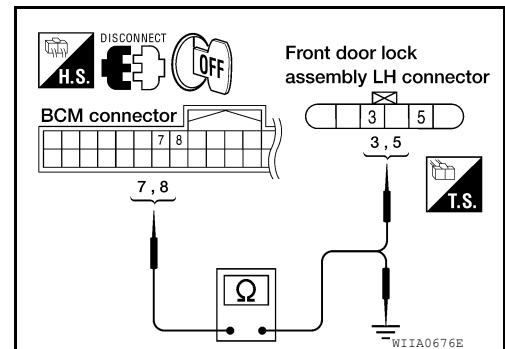

### Is the inspection result normal?

- YES >> GO TO 4
- NO >> Repair or replace harness.

## 4. CHECK FRONT DOOR LOCK ASSEMBLY LH GROUND

Check continuity between front door lock assembly LH connector D14 terminal 4 and ground.

**4 - Ground : Continuity should exist.**

### Is the inspection result normal?

- YES >> GO TO 5
- NO >> Repair or replace harness.

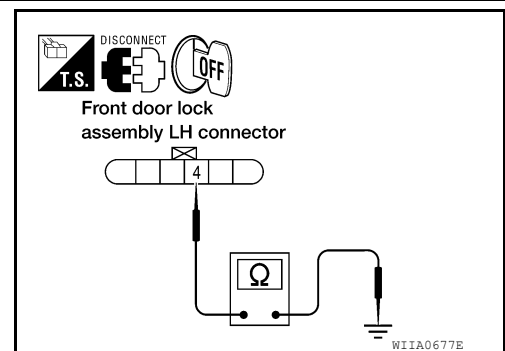

## 5. CHECK BCM OUTPUT VOLTAGE

1. Connect BCM.



# KEY CYLINDER SWITCH

## < DTC/CIRCUIT DIAGNOSIS >

2. Check voltage between BCM connector M18 terminals 7, 8 and ground.

**7 - Ground : Approx. 5V**

**8 - Ground : Approx. 5V**

### Is the inspection result normal?

YES >> Check condition of the harness and connector.

NO >> Replace BCM. Refer to [BCS-49. "Removal and Installation"](#).

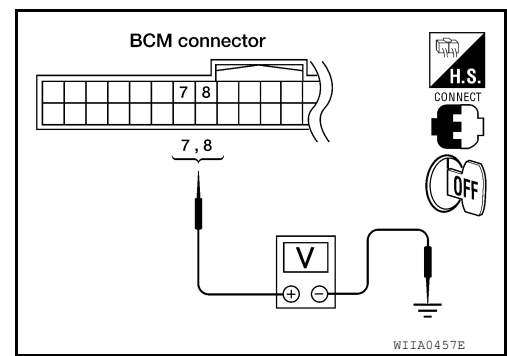

A  
B  
C  
D  
E  
F  
G  
H  
I  
J  
DLK  
L  
M  
N  
O  
P

# KEY SWITCH (BCM INPUT)

< DTC/CIRCUIT DIAGNOSIS >

## KEY SWITCH (BCM INPUT)

### Diagnosis Procedure

INFOID:000000008792281

Regarding Wiring Diagram information, refer to [DLK-77. "Wiring Diagram - King Cab"](#) or [DLK-87. "Wiring Diagram - Crew Cab"](#).

### 1. CHECK KEY SWITCH INPUT SIGNAL

#### With CONSULT

Check key switch "KEY ON SW" in DATA MONITOR mode with CONSULT. Refer to [BCS-15. "DOOR LOCK : CONSULT Function \(BCM - DOOR LOCK\)"](#).

- When key is inserted to ignition key cylinder:

**KEY ON SW : ON**

- When key is removed from ignition key cylinder:

**KEY ON SW : OFF**

#### Without CONSULT

Check voltage between BCM connector M18 terminal 37 and ground.

Connector	Terminal		Condition	Voltage (V)
	(+)	(-)		
M18	37	Ground	Key is inserted.	Battery voltage
			Key is removed.	0

Is the inspection result normal?

- YES >> Key switch (insert) circuit is OK.
- NO >> GO TO 2

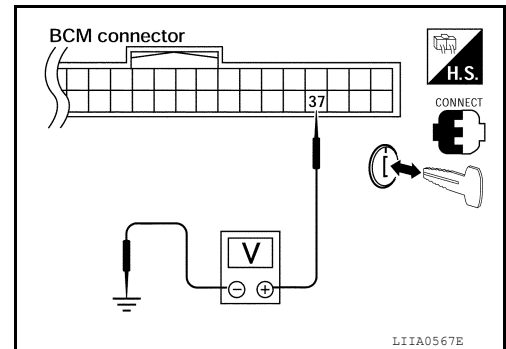

### 2. CHECK KEY SWITCH (INSERT)

- Turn ignition switch OFF.
- Disconnect key switch connector.
- Check continuity between key switch terminals.

Terminals	Condition	Continuity
1 - 2	Key is inserted.	Yes
	Key is removed.	No

Is the inspection result normal?

- YES >> Repair or replace harness or fuse.
- NO >> Replace key switch.

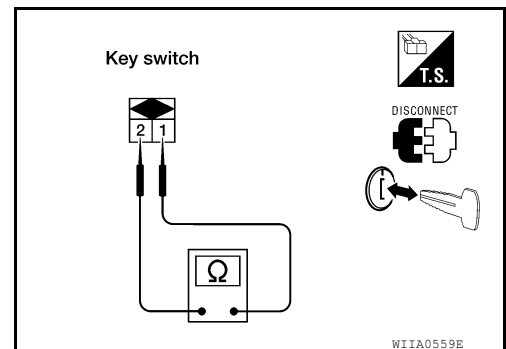

# DOOR LOCK ACTUATOR

< DTC/CIRCUIT DIAGNOSIS >

## DOOR LOCK ACTUATOR DRIVER SIDE

### DRIVER SIDE : Description

INFOID:000000008792282

Locks/unlocks the door with the signal from BCM.

### DRIVER SIDE : Component Function Check

INFOID:000000008792283

#### 1. CHECK FUNCTION

1. Use CONSULT to perform Active Test "DOOR LOCK".
2. Touch "ALL LCK" or "ALL ULK" to check that it works normally.

Is the inspection result normal?

- YES >> Door lock actuator is OK.  
NO >> Refer to [DLK-43. "DRIVER SIDE : Diagnosis Procedure"](#).

### DRIVER SIDE : Diagnosis Procedure

INFOID:000000008792284

Regarding Wiring Diagram information, refer to [DLK-77. "Wiring Diagram - King Cab"](#) or [DLK-87. "Wiring Diagram - Crew Cab"](#).

#### 1. CHECK DOOR LOCK ACTUATOR SIGNAL

1. Turn ignition switch OFF.
2. Check voltage between BCM connector M20 terminals 59, 65 and ground.

Connector	Terminals		Condition	Voltage (V) (Approx.)
	(+)	(-)		
M20	59	Ground	Driver door lock/unlock switch is turned to UN-LOCK	0 → Battery voltage
	65		Driver door lock/unlock switch is turned to LOCK	0 → Battery voltage

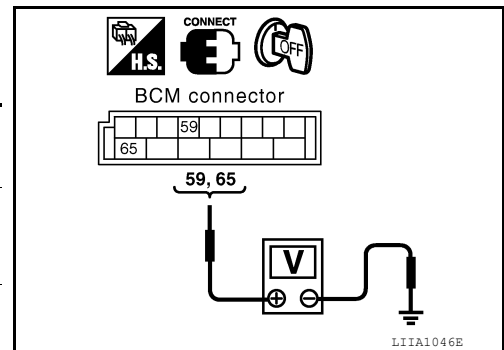

Is the inspection result normal?

- YES >> GO TO 2  
NO >> GO TO 3

#### 2. CHECK DOOR LOCK ACTUATOR HARNESS

1. Disconnect BCM and front door lock assembly LH (actuator).
2. Check continuity between BCM connector (A) M20 terminals 59, 65 and front door lock assembly LH (actuator) connector (B) D14 terminals 1, 2.

Connector	Terminals	Connector	Terminals	Continuity
M20	59	D14	2	Yes
	65		1	

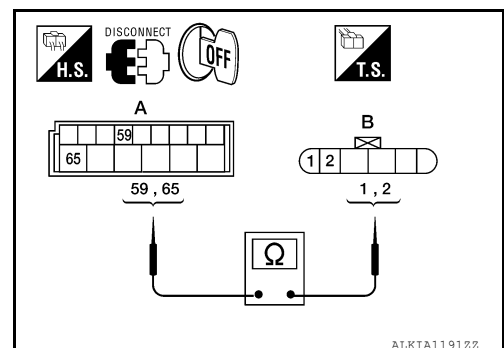

Is the inspection result normal?

- YES >> Replace front door lock assembly LH (actuator).

# DOOR LOCK ACTUATOR

## < DTC/CIRCUIT DIAGNOSIS >

NO >> Repair or replace harness.

### 3. CHECK DOOR LOCK ACTUATOR HARNESS

1. Disconnect BCM and front door lock assembly LH (actuator).
2. Check continuity between BCM connector M20 terminals 59, 65 and ground.

Connector	Terminals		Continuity
M20	59	Ground	No
	65		

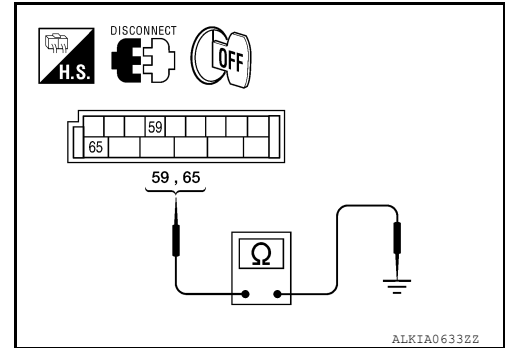

Is the inspection result normal?

YES >> Replace BCM. Refer to [BCS-49. "Removal and Installation"](#).

NO >> Repair or replace harness.

## PASSENGER SIDE

### PASSENGER SIDE : Description

INFOID:000000008792285

Locks/unlocks the door with the signal from BCM.

### PASSENGER SIDE : Component Function Check

INFOID:000000008792286

### 1. CHECK FUNCTION

1. Use CONSULT to perform Active Test "DOOR LOCK".
2. Touch "ALL LCK" or "ALL ULK" to check that it works normally.

Is the inspection result normal?

YES >> Door lock actuator is OK.

NO >> Refer to [DLK-44. "PASSENGER SIDE : Diagnosis Procedure"](#).

### PASSENGER SIDE : Diagnosis Procedure

INFOID:000000008792287

Regarding Wiring Diagram information, refer to [DLK-77. "Wiring Diagram - King Cab"](#) or [DLK-87. "Wiring Diagram - Crew Cab"](#).

### 1. CHECK FRONT DOOR LOCK ACTUATOR RH SIGNAL

1. Turn ignition switch OFF.
2. Check voltage between BCM connector M20 terminals 65, 66 and ground.

Connector	Terminals		Condition	Voltage (V) (Approx.)
	(+)	(-)		
M20	65	Ground	Door lock/unlock switch is turned to LOCK	0 → Battery voltage for 300 ms
	66		Door lock/unlock switch is turned to UNLOCK	

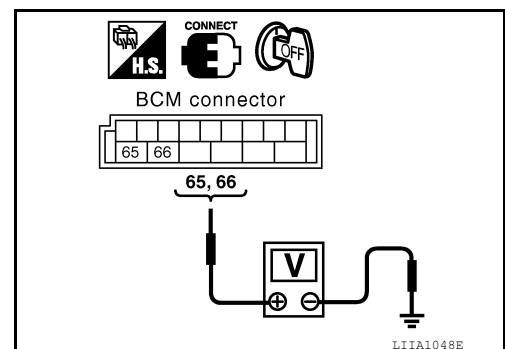

Is the inspection result normal?

YES >> GO TO 2

# DOOR LOCK ACTUATOR

## < DTC/CIRCUIT DIAGNOSIS >

NO >> GO TO 3

### 2. CHECK DOOR LOCK ACTUATOR HARNESS

1. Disconnect BCM and front door lock actuator RH.
2. Check continuity between BCM connector (A) M20 terminals 65, 66 and front door lock actuator RH (B) D114 terminals 1, 2.

Terminal		Continuity
65	2	Yes
66	1	

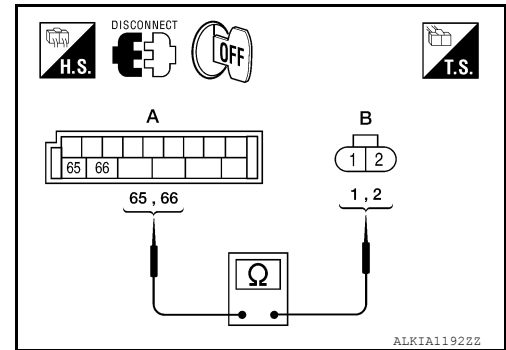

Is the inspection result normal?

- YES >> Replace front door lock actuator RH. Refer to [DLK-136. "Removal and Installation"](#).  
 NO >> Repair or replace harness.

### 3. CHECK DOOR LOCK ACTUATOR HARNESS

1. Disconnect BCM and front door lock actuator RH.
2. Check continuity between BCM connector M19 terminals 65, 66 and ground.

Terminals		Continuity
65	Ground	No
66		

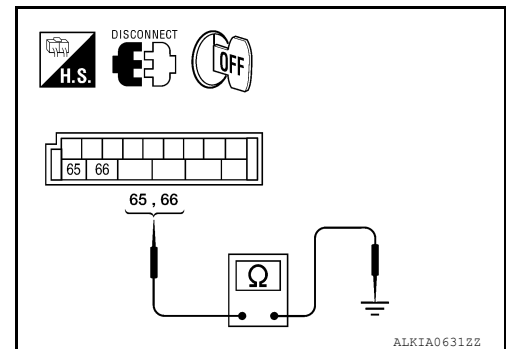

Is the inspection result normal?

- YES >> Replace BCM. Refer to [BCS-49. "Removal and Installation"](#).  
 NO >> Repair or replace harness.

## REAR LH

### REAR LH : Description

Locks/unlocks the door with the signal from BCM.

INFOID:000000008792288

### REAR LH : Component Function Check

INFOID:000000008792289

### 1. CHECK FUNCTION

1. Use CONSULT to perform Active Test "DOOR LOCK".
2. Touch "ALL LCK" or "ALL ULK" to check that it works normally.

Is the inspection result normal?

- YES >> Door lock actuator is OK.  
 NO >> Refer to [DLK-45. "REAR LH : Diagnosis Procedure"](#).

### REAR LH : Diagnosis Procedure

INFOID:000000008792290

Regarding Wiring Diagram information, refer to [DLK-87. "Wiring Diagram - Crew Cab"](#).

# DOOR LOCK ACTUATOR

## < DTC/CIRCUIT DIAGNOSIS >

### 1. CHECK DOOR LOCK ACTUATOR SIGNAL

1. Turn ignition switch OFF.
2. Check voltage between BCM connector M20 terminals 65, 66 and ground.

Connector	Terminals		Condition	Voltage (V) (Approx.)
	(+)	(-)		
M20	65	Ground	Door lock/unlock switch is turned to LOCK	0 → Battery voltage for 300 ms
	66		Door lock/unlock switch is turned to UNLOCK	

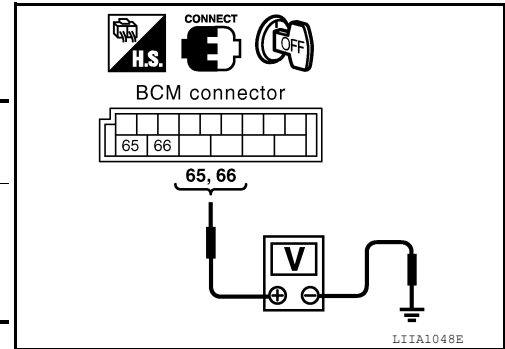

#### Is the inspection result normal?

- YES >> GO TO 2  
NO >> GO TO 3

### 2. CHECK DOOR LOCK ACTUATOR HARNESS

1. Disconnect BCM and rear door lock actuator LH.
2. Check continuity between BCM connector (A) M20 terminals 65, 66 and rear door lock actuator LH connector (B) D205 terminals 1, 2.

Terminals		Continuity
65	2	
66	1	

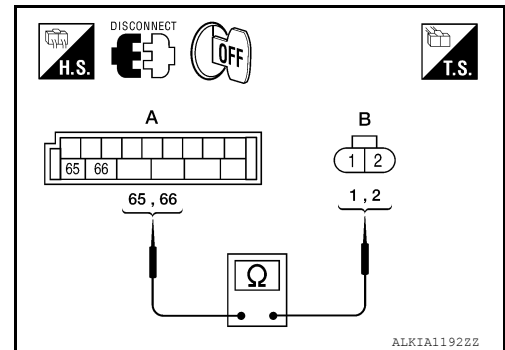

#### Is the inspection result normal?

- YES >> Replace rear door lock actuator LH.  
NO >> Repair or replace harness.

### 3. CHECK DOOR LOCK ACTUATOR HARNESS

1. Disconnect BCM and each door lock actuator.
2. Check continuity between BCM connector M20 terminals 65, 66 and ground.

Terminals		Continuity
65	Ground	
66		No

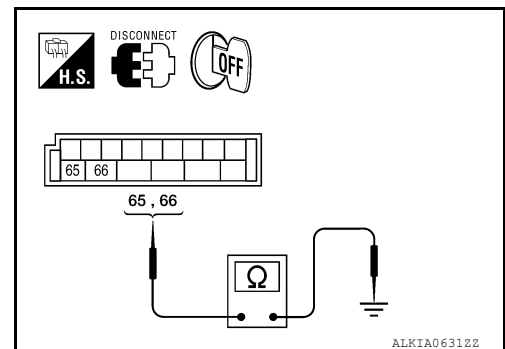

#### Is the inspection result normal?

- YES >> Replace BCM. Refer to [BCS-49. "Removal and Installation"](#).  
NO >> Repair or replace harness.

## REAR RH

# DOOR LOCK ACTUATOR

< DTC/CIRCUIT DIAGNOSIS >

## REAR RH : Description

INFOID:000000008792291

Locks/unlocks the door with the signal from BCM.

## REAR RH : Component Function Check

INFOID:000000008792292

### 1.CHECK FUNCTION

1. Use CONSULT to perform Active Test "DOOR LOCK".
2. Touch "ALL LCK" or "ALL ULK" to check that it works normally.

Is the inspection result normal?

- YES >> Door lock actuator is OK.  
 NO >> Refer to [DLK-47, "REAR RH : Diagnosis Procedure"](#).

## REAR RH : Diagnosis Procedure

INFOID:000000008792293

Regarding Wiring Diagram information, refer to [DLK-87, "Wiring Diagram - Crew Cab"](#).

### 1.CHECK DOOR LOCK ACTUATOR SIGNAL

1. Turn ignition switch OFF.
2. Check voltage between BCM connector M20 terminals 65, 66 and ground.

Connector	Terminals		Condition	Voltage (V) (Approx.)
	(+)	(-)		
M20	65	Ground	Door lock/unlock switch is turned to LOCK	0 → Battery voltage for 300 ms
	66		Door lock/unlock switch is turned to UNLOCK	

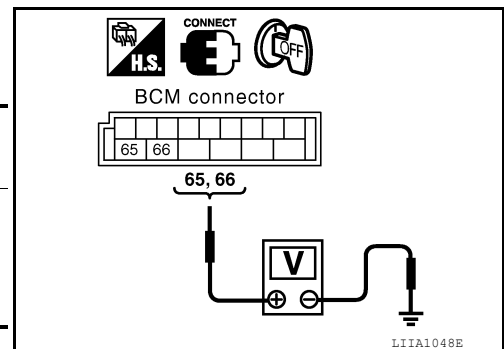

Is the inspection result normal?

- YES >> GO TO 2  
 NO >> GO TO 3

### 2.CHECK DOOR LOCK ACTUATOR HARNESS

1. Disconnect BCM and rear door lock actuator RH.
2. Check continuity between BCM connector (A) M20 terminals 65, 66 and rear door lock actuator RH connector (B) D305 terminals 1, 2.

Terminals		Continuity
(+)	(-)	
65	2	Yes
66	1	

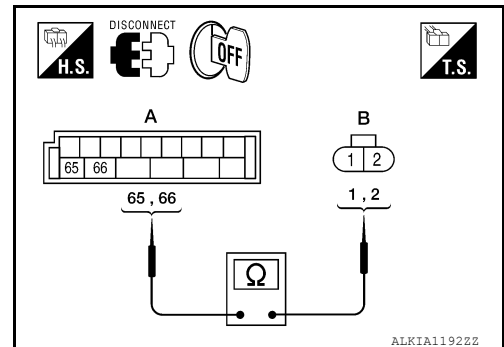

Is the inspection result normal?

- YES >> Replace rear door lock actuator RH.  
 NO >> Repair or replace harness.

### 3.CHECK DOOR LOCK ACTUATOR HARNESS

1. Disconnect BCM and rear door lock actuator RH.

A  
B  
C  
D  
E  
F  
G  
H  
I  
J  
L  
M  
N  
O  
P

DLK

## DOOR LOCK ACTUATOR

### < DTC/CIRCUIT DIAGNOSIS >

2. Check continuity between BCM connector (A) M20 terminals 65, 66 and ground.

Terminals		Continuity
65	Ground	No
66		

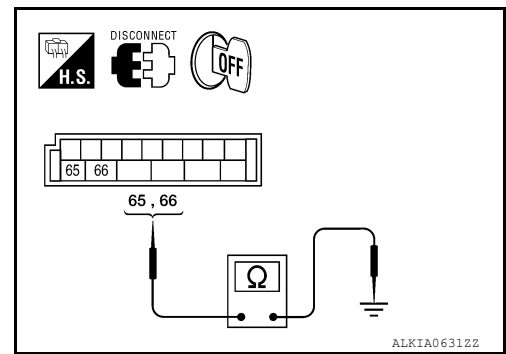

### Is the inspection result normal?

YES >> Replace BCM. Refer to [BCS-49. "Removal and Installation"](#).

NO >> Repair or replace harness.



# REMOTE KEYLESS ENTRY RECEIVER

< DTC/CIRCUIT DIAGNOSIS >

## REMOTE KEYLESS ENTRY RECEIVER

### Description

INFOID:000000008792294

Receives keyfob operation and transmits to BCM.

### Component Function Check

INFOID:000000008792295

#### 1. CHECK FUNCTION

##### With CONSULT

Check remote keyless entry receiver by pressing the keyfob lock and unlock buttons then monitoring "KEYLESS LOCK" and "KEYLESS UNLOCK" in Data Monitor mode "DOOR LOCK" with CONSULT.

Monitor item	Condition
KEYLESS LOCK	LOCK : ON
	UNLOCK : OFF
KEYLESS UNLOCK	LOCK : OFF
	UNLOCK : ON

Is the inspection result normal?

- YES >> Remote keyless entry receiver is OK.
- NO >> Refer to [DLK-49. "Diagnosis Procedure"](#).



### Diagnosis Procedure

INFOID:000000008792296

Regarding Wiring Diagram information, refer to [DLK-97. "Wiring Diagram - King Cab"](#) or [DLK-107. "Wiring Diagram - Crew Cab"](#).

#### 1. CHECK REMOTE KEYLESS ENTRY RECEIVER OUTPUT SIGNAL

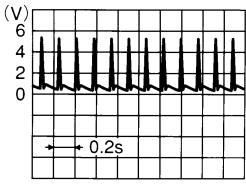
1. Turn ignition switch OFF.
2. Check remote keyless entry receiver signal with an oscilloscope.

Terminals		Keyfob condition	Signal (Reference value)
(+)	(-)		
Remote keyless entry receiver connector	Terminal		
M120	2	Ground	 <p>OCC3879D</p>
		Any button is pressed	 <p>OCC3880D</p>

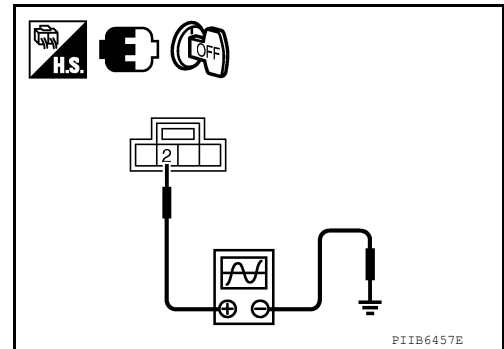

# REMOTE KEYLESS ENTRY RECEIVER

## < DTC/CIRCUIT DIAGNOSIS >

### Is the inspection result normal?

- YES >> GO TO 2
- NO >> GO TO 4

## 2. REMOTE KEYLESS ENTRY RECEIVER 5-VOLT CIRCUIT INSPECTION

Check voltage between remote keyless entry receiver connector M120 terminal 4 and ground.

**4 - Ground : Approx. 5 volt.**

### Is the inspection result normal?

- YES >> GO TO 3
- NO >> GO TO 4

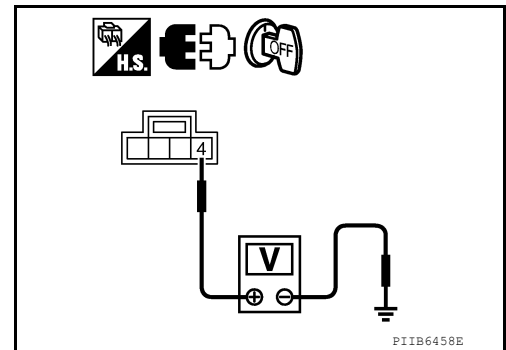

## 3. REMOTE KEYLESS ENTRY RECEIVER GROUND CIRCUIT INSPECTION

Check continuity between remote keyless entry receiver connector M120 terminal 1 and ground.

**1 - Ground : Continuity should exist.**

### Is the inspection result normal?

- YES >> Replace remote keyless entry receiver.
- NO >> GO TO 4

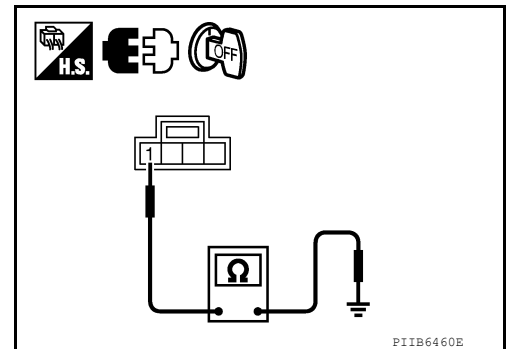

## 4. HARNESS INSPECTION BETWEEN BCM AND RKE RECEIVER

1. Disconnect remote keyless entry receiver and BCM connectors.
2. Check continuity between BCM connector M18 terminals 18, 19, 20 and remote keyless entry receiver connector M120 terminals 1, 2, 4.

**1 - 18 : Continuity should exist.**  
**2 - 20 : Continuity should exist.**  
**4 - 19 : Continuity should exist.**

3. Check continuity between remote keyless entry receiver connector M120 terminals 1, 2, 4 and ground.

**1 - Ground : Continuity should not exist.**  
**2 - Ground : Continuity should not exist.**  
**4 - Ground : Continuity should not exist.**

### Is the inspection result normal?

- YES >> Replace remote keyless entry receiver.
- NO >> Repair or replace the harness between the remote keyless entry receiver and BCM.

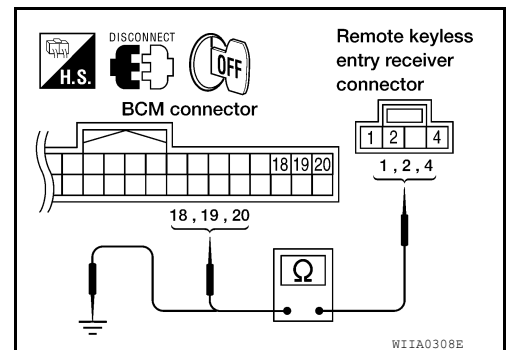

# KEYFOB BATTERY AND FUNCTION

< DTC/CIRCUIT DIAGNOSIS >

## KEYFOB BATTERY AND FUNCTION

### Description

INFOID:000000008792297

The following functions are available when having and carrying electronic ID.

- Door lock/unlock
- Panic alarm

Remote control entry function and panic alarm function are available when operating the remote buttons.

### Component Function Check

INFOID:000000008792298

#### NOTE:

The Signal Tech II (J-50190) can be used to test the remote keyless entry keyfob relative signal strength. Refer to the Signal Tech II User Guide for additional information.

#### 1. CHECK FUNCTION

##### With CONSULT

Check remote keyless entry receiver by pressing the keyfob lock and unlock buttons then monitoring "KEYLESS LOCK" and "KEYLESS UNLOCK" in Data Monitor mode "DOOR LOCK" with CONSULT.

Monitor item	Condition
KEYLESS LOCK	LOCK : ON
	UNLOCK : OFF
KEYLESS UNLOCK	LOCK : OFF
	UNLOCK : ON

Is the inspection result normal?

- YES >> Keyfob is OK.  
 NO >> Refer to [DLK-51, "Diagnosis Procedure"](#).

### Diagnosis Procedure

INFOID:000000008792299

#### NOTE:

The Signal Tech II (J-50190) can be used to test the remote keyless entry keyfob relative signal strength. Refer to the Signal Tech II User Guide for additional information.

#### 1. CHECK KEYFOB FUNCTION

Check keyfob function using Signal Tech II Tool J-50190 or Remote Keyless Entry Tester J-43241 (shown).

Does the test pass?

- YES >> Keyfob is OK.  
 NO >> GO TO 2

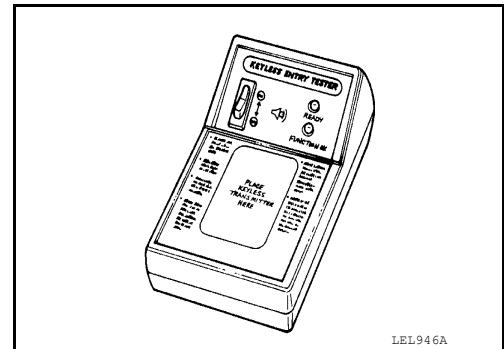

#### 2. CHECK KEYFOB COMPONENTS

A  
B  
C  
D  
E  
F  
G  
H  
I  
J  
DLK  
L  
M  
N  
O  
P

# KEYFOB BATTERY AND FUNCTION

## < DTC/CIRCUIT DIAGNOSIS >

1. Open the lid using a coin.
  - CAUTION:**
  - Do not touch the circuit board or battery terminal.
  - The keyfob is water-resistant. However, if it does get wet, immediately wipe it dry.
2. Remove the keyfob battery.
  - CAUTION:**
  - Keep dirt, grease, and other foreign materials off the electrode contact area.
3. Visually inspect keyfob internal components.

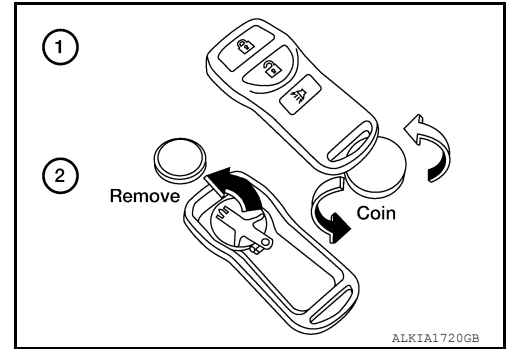

Is the inspection result normal?

- YES >> GO TO 3  
 NO >> Repair or replace malfunctioning parts.

## 3. CHECK KEYFOB BATTERY

Check by connecting a resistance (approximately 300Ω) so that the current value becomes about 10 mA.

**Standard : Approx. 2.5 - 3.0V**

Is the measurement value within specification?

- YES >> Keyfob battery is OK. Check remote keyless entry receiver. Refer to [DLK-49](#).  
"Component Function Check".  
 NO >> GO TO 4.

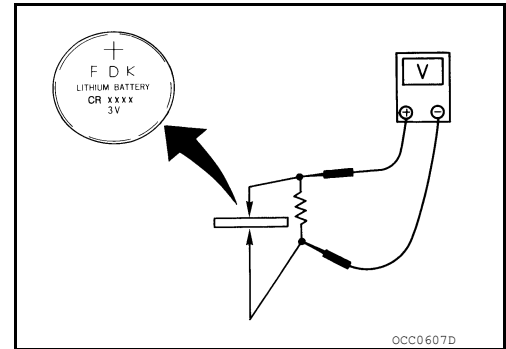

## 4. REPLACE KEYFOB BATTERY

1. Replace the keyfob battery, positive side down.
2. Align the tips of the upper and lower parts, and then push them together until it is securely closed.
  - CAUTION:**
  - When replacing battery, keep dirt, grease, and other foreign materials off the electrode contact area.
3. After replacing the battery, check that all keyfob functions work properly.

Is the inspection result normal?

- YES >> Keyfob is OK.  
 NO >> Check remote keyless entry receiver. Refer to [DLK-49](#).  
"Component Function Check".

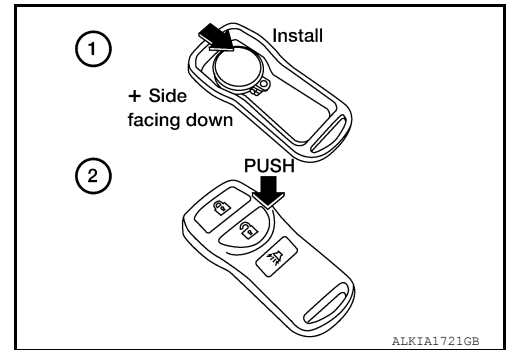

# HORN FUNCTION

< DTC/CIRCUIT DIAGNOSIS >

## HORN FUNCTION

### Description

INFOID:000000008792300

Perform answer-back for each operation with horn.

### Component Function Check

INFOID:000000008792301

#### 1.CHECK FUNCTION

1. Use CONSULT to perform Active Test "MULTIREMOTE ENT".
2. Touch "HORN" to check that it works normally.

Test item		Description	
HORN	ON	Horn relay	ON (for 20 ms)

Is the operation normal?

- YES >> Inspection End.  
 NO >> Refer to [DLK-53, "Diagnosis Procedure"](#).

### Diagnosis Procedure

INFOID:000000008792302

Regarding Wiring Diagram information, refer to [DLK-97, "Wiring Diagram - King Cab"](#) or [DLK-107, "Wiring Diagram - Crew Cab"](#).

#### 1.CHECK HORN FUNCTION

Check horn function with horn switch

Do the horns sound?

- YES >> GO TO 2  
 NO >> Refer to [HRN-3, "Wiring Diagram"](#).

#### 2.CHECK HORN RELAY POWER SUPPLY

1. Turn ignition switch ON.
2. Perform "HORN" in Active Test mode for "MULTIREMOTE ENT" with CONSULT.
3. Using an oscilloscope or analog voltmeter, check voltage between IPDM E/R connector E122 terminal 45 and ground.

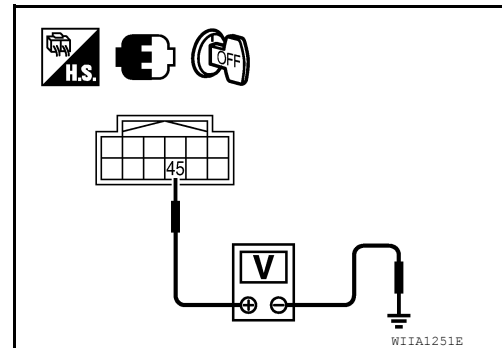

IPDM E/R		Ground	Test item	Voltage (V) (Approx.)
Connector	Terminal			
E122	45	Ground	HORN	OFF → ON → OFF
				Other than above
				Battery voltage → 0 → Battery voltage
				Battery voltage

Is the inspection result normal?

- YES >> Refer to [GI-49, "Intermittent Incident"](#).  
 NO >> GO TO 3

#### 3.CHECK HORN RELAY CIRCUIT

A  
B  
C  
D  
E  
F  
G  
H  
I  
J  
L  
M  
N  
O  
P

DLK

# HORN FUNCTION

## < DTC/CIRCUIT DIAGNOSIS >

1. Turn ignition switch OFF.
2. Disconnect IPDM E/R and horn relay connector.
3. Check continuity between IPDM E/R harness connector and horn relay harness connector.

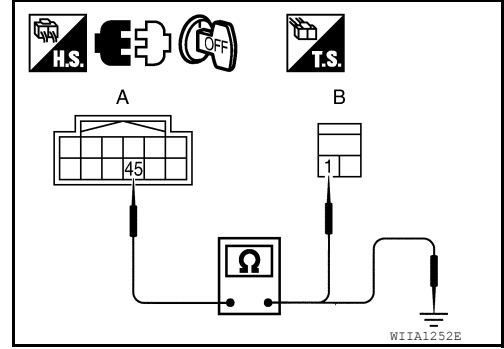

IPDM E/R		Horn relay		Continuity
Connector	Terminal	Connector	Terminal	
A: E122	45	B: H-1	1	Yes

4. Check continuity between IPDM E/R harness connector and ground.

IPDM E/R		Ground	Continuity
Connector	Terminal		
E122	45	Ground	No

Is the inspection result normal?

- YES >> GO TO 4  
 NO >> Repair or replace harness.

## 4. CHECK INTERMITTENT INCIDENT

Refer to [GI-49. "Intermittent Incident"](#).

Is the inspection result normal?

- YES >> Replace IPDM E/R. Refer to [PCS-28. "Removal and Installation of IPDM E/R"](#).  
 NO >> Repair or replace the malfunctioning part.

# WARNING CHIME FUNCTION

< DTC/CIRCUIT DIAGNOSIS >

## WARNING CHIME FUNCTION

### Description

INFOID:000000008792303

Performs operation method guide and warning with buzzer.

### Component Function Check

INFOID:000000008792304

#### 1.CHECK FUNCTION

1. Use CONSULT to perform Active Test "BUZZER".
2. Touch "IGN KEY WARN ALM" to check that it works normally.

Is the inspection result normal?

- Yes >> Warning buzzer in combination meter is OK.
- No >> Refer to [DLK-55. "Diagnosis Procedure"](#).

### Diagnosis Procedure

INFOID:000000008792305

#### 1.CHECK METER BUZZER CIRCUIT

The inoperative warning chime is contained inside the combination meter. Refer to [MWI-4. "Work Flow"](#).

>> Inspection End.

A  
B  
C  
D  
E  
F  
G  
H  
I  
J  
L  
M  
N  
O  
P

DLK

# HAZARD FUNCTION

< DTC/CIRCUIT DIAGNOSIS >

---

## HAZARD FUNCTION

### Description

INFOID:000000008792306

Perform answer-back for each operation with number of blinks.

### Component Function Check

INFOID:000000008792307

#### 1.CHECK FUNCTION

---

1. Use CONSULT to perform Active Test "FLASHER".
2. Touch "RH" and "LH" to check that it works normally.

Is the inspection result normal?

- YES >> Hazard warning lamp circuit is OK.  
NO >> Refer to [DLK-56, "Diagnosis Procedure"](#).

### Diagnosis Procedure

INFOID:000000008792308

#### 1.CHECK HAZARD SWITCH CIRCUIT

---

Operate the hazard lights by turning ON the hazard warning switch.

Do the lights operate normally?

- YES >> Replace the BCM. Refer to [BCS-49, "Removal and Installation"](#).  
NO >> Repair or replace hazard warning switch circuit. Refer to [EXL-96, "Wiring Diagram"](#).



# HEADLAMP FUNCTION

< DTC/CIRCUIT DIAGNOSIS >

## HEADLAMP FUNCTION

---

### Diagnosis Procedure

INFOID:000000008792309

#### 1. CHECK HEADLAMP OPERATION

---

Do headlamps operate with headlamp switch?

YES or NO

YES >> Headlamp circuit is OK.

NO >> Check headlamp circuit. Refer to [EXL-73, "Wiring Diagram"](#).

A  
B  
C  
D  
E  
F  
G  
H  
I  
J  
DLK  
L  
M  
N  
O  
P

DLK

# MAP LAMP AND IGNITION KEYHOLE ILLUMINATION FUNCTION

< DTC/CIRCUIT DIAGNOSIS >

---

## MAP LAMP AND IGNITION KEYHOLE ILLUMINATION FUNCTION

### Diagnosis Procedure

INFOID:000000008792310

#### 1. CHECK MAP LAMP OPERATION

---

When room lamp switch is in "DOOR" position, open the driver or passenger door.  
Map lamp and ignition keyhole illumination should illuminate.

Is the inspection result normal?

YES >> Map lamp circuit is OK.

NO >> Check map lamp circuit. Refer to [INL-24. "Description"](#).

# KEYFOB ID SET UP WITH CONSULT

< DTC/CIRCUIT DIAGNOSIS >

## KEYFOB ID SET UP WITH CONSULT

### ID Code Entry Procedure

INFOID:000000008792311

### KEYFOB ID SET UP WITH CONSULT

#### NOTE:

- If a keyfob is lost, the ID code of the lost keyfob must be erased to prevent unauthorized use. A specific ID code can be erased with CONSULT. However, when the ID code of a lost keyfob is not known, all controller ID codes should be erased. After all ID codes are erased, the ID codes of all remaining and/or new keyfobs must be re-registered.
- When registering an additional keyfob, the existing ID codes in memory may or may not be erased. If five ID codes are stored in memory when an additional code is registered, only the oldest code is erased. If less than five codes are stored in memory when an additional code is registered, the new ID code is added and no ID codes are erased.
- Entry of a maximum of five ID codes is allowed. When more than five codes are entered, the oldest ID code will be erased.
- Even if the same ID code that is already in memory is input, the same ID code can be entered. The code is counted as an additional code.

1. Turn ignition switch ON.
2. Select "BCM".
3. Select "MULTIREMOTE ENT".
4. Select "WORK SUPPORT".
5. You can register, erase or confirm a keyfob ID code. To register a new code, select the following option and follow CONSULT instructions:
  - "REMO CONT ID REGIST"  
Use this item to register a keyfob ID code.

#### NOTE:

**Register the ID code when keyfob or BCM is replaced, or when an additional keyfob is required.**

- "REMO CONT ID ERASUR"  
Use this item to erase a keyfob ID code.
- "REMO CONT ID CONFIR"  
Use this item to confirm if a keyfob ID code is registered or not.

A  
B  
C  
D  
E  
F  
G  
H  
I  
J  
DLK  
L  
M  
N  
O  
P

# KEYFOB ID SET UP WITHOUT CONSULT

< DTC/CIRCUIT DIAGNOSIS >

## KEYFOB ID SET UP WITHOUT CONSULT

### ID Code Entry Procedure

INFOID:000000008792312

### KEYFOB ID SET UP WITHOUT CONSULT

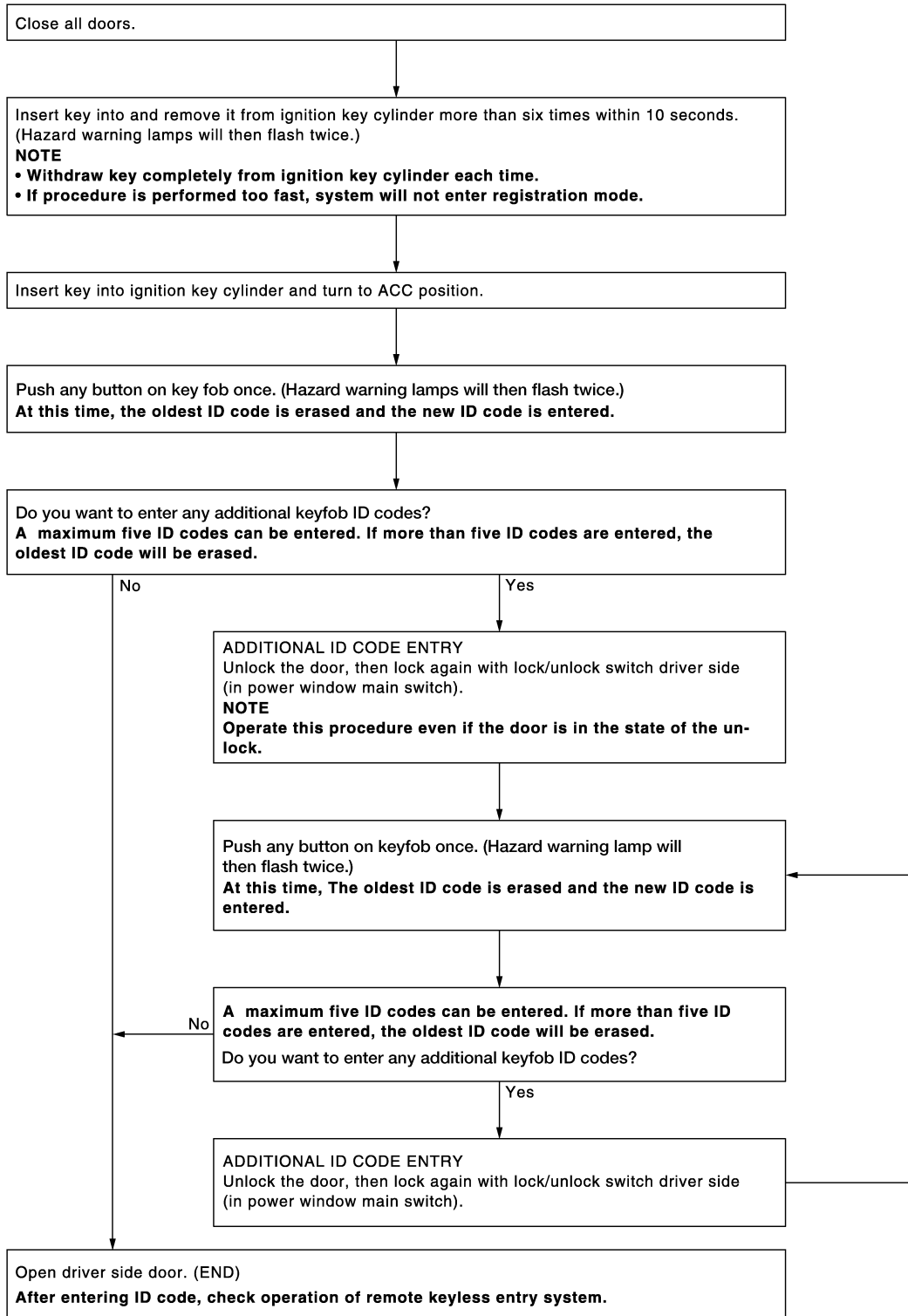

LI1A1670E

#### NOTE:

- If a keyfob is lost, the ID code of the lost keyfob must be erased to prevent unauthorized use. A specific ID code can be erased with CONSULT. However, when the ID code of a lost keyfob is not known, all controller

## KEYFOB ID SET UP WITHOUT CONSULT

### < DTC/CIRCUIT DIAGNOSIS >

---

ID codes should be erased. After all ID codes are erased, the ID codes of all remaining and/or new keyfobs must be re-registered.

To erase all ID codes in memory, register one ID code (keyfob) five times. After all ID codes are erased, the ID codes of all remaining and/or new keyfobs must be re-registered.

- When registering an additional keyfob, the existing ID codes in memory may or may not be erased. If five ID codes are stored in memory, when an additional code is registered, only the oldest code is erased. If less than five ID codes are stored in memory, when an additional ID code is registered, the new ID code is added and no ID codes are erased.
- If you need to activate more than two additional new keyfobs, repeat the procedure “Additional ID code entry” for each new keyfob.
- Entry of maximum five ID codes is allowed. When more than five ID codes are entered, the oldest ID code will be erased.
- Even if same ID code that is already in the memory is input, the same ID code can be entered. The code is counted as an additional code.

A

B

C

D

E

F

G

H

I

J

**DLK**

L

M

N

O

P

# HOMELINK UNIVERSAL TRANSCEIVER

< DTC/CIRCUIT DIAGNOSIS >

## HOMELINK UNIVERSAL TRANSCEIVER

### Description

INFOID:000000008792313

Homelink universal transceiver can store and transmit a maximum of 3 radio signals. Allows operation of garage doors, gates, home and office lighting, entry door locks and security system, etc. Homelink universal transceiver power supply uses vehicle battery, which enables it to maintain every program in case battery is discharged or removed.

### Component Function Check

INFOID:000000008792314

#### 1. CHECK FUNCTION

Check that system receiver (garage door opener, etc.) operates with original hand-held transmitter.

Is the inspection result normal?

- YES >> GO TO 2
- NO >> Receiver or hand-held transmitter is malfunctioning.

#### 2. CHECK ILLUMINATION

1. Turn ignition switch "OFF".
2. Press each of the transmitter buttons and watch for the red light to illuminate with each button.

Is the inspection result normal?

- YES >> GO TO 3
- NO >> Refer to [DLK-62, "Diagnosis Procedure"](#).

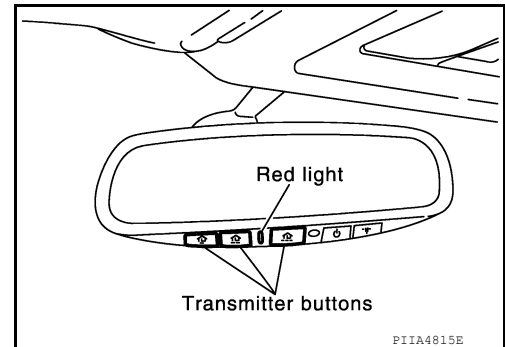

#### 3. CHECK TRANSMITTER

Check transmitter with Tool\*.

\*:For details, refer to Technical Service Bulletin.

Is the inspection result normal?

- YES >> Receiver or hand-held transmitter malfunction, not vehicle related.
- NO >> Replace auto anti-dazzling inside mirror (homelink universal transceiver).

### Diagnosis Procedure

INFOID:000000008792315

Regarding Wiring Diagram information, refer to [DLK-75, "Wiring Diagram"](#).

#### 1. CHECK POWER SUPPLY

1. Disconnect auto anti-dazzling inside mirror (homelink universal transceiver) connector.
2. Check voltage between auto anti-dazzling inside mirror (homelink universal transceiver) harness connector and ground.

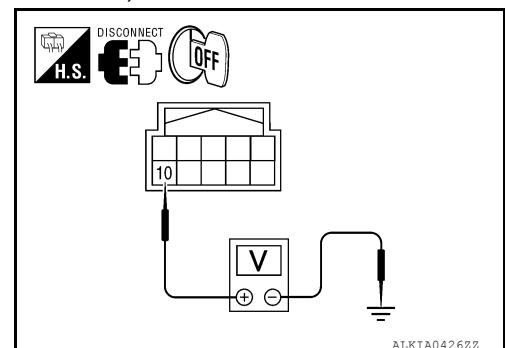

# HOMELINK UNIVERSAL TRANSCEIVER

## < DTC/CIRCUIT DIAGNOSIS >

Auto anti-dazzling inside mirror (Homelink universal transceiver) connector	Terminal		Condition	Voltage (V) (Approx.)
R7	10	Ground	Ignition switch position: LOCK	Battery voltage

### Is the inspection result normal?

YES >> GO TO 2

NO >> Check the following.

- 10A fuse [No. 19 located in the fuse block (J/B)]
- Harness for open or short between fuse and auto anti-dazzling inside mirror (homelink universal transceiver).

## 2.CHECK GROUND CIRCUIT

Check continuity between auto anti-dazzling inside mirror (homelink universal transceiver) harness connector and ground.

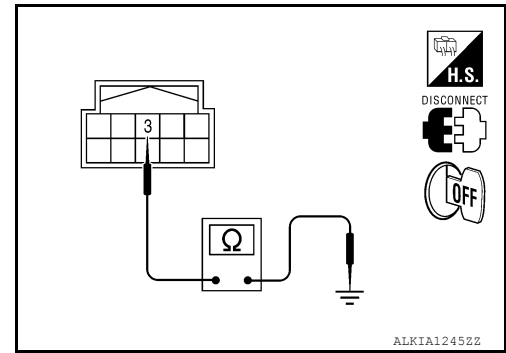

Auto anti-dazzling inside mirror (Homelink universal transceiver) connector	Terminal	Ground	Continuity
R7	3		Yes

### Is the inspection result normal?

YES >> GO TO 3

NO >> Repair harness.

## 3.CHECK INTERMITTENT INCIDENT

Refer to [GI-49. "Intermittent Incident"](#).

>> Inspection End.

A  
B  
C  
D  
E  
F  
G  
H  
I  
J  
L  
M  
N  
O  
P

DLK

# BCM (BODY CONTROL MODULE)

< ECU DIAGNOSIS INFORMATION >

## ECU DIAGNOSIS INFORMATION

### BCM (BODY CONTROL MODULE)

#### Reference Value

INFOID:000000009232914

#### NOTE:

The Signal Tech II Tool (J-50190) can be used to perform the following functions. Refer to the Signal Tech II User Guide for additional information.

- Activate and display TPMS transmitter IDs
- Display tire pressure reported by the TPMS transmitter
- Read TPMS DTCs
- Register TPMS transmitter IDs
- Test remote keyless entry keyfob relative signal strength

#### VALUES ON THE DIAGNOSIS TOOL

Monitor Item	Condition	Value/Status
ACC ON SW	Ignition switch OFF or ON	Off
	Ignition switch ACC	On
AIR COND SW	A/C switch OFF	Off
	A/C switch ON	On
AIR PRESS FL	Front left tire air pressure value	kPa, kg/cm <sup>2</sup> , psi
AIR PRESS FR	Front right tire air pressure value	kPa, kg/cm <sup>2</sup> , psi
AIR PRESS RL	Rear left tire air pressure value	kPa, kg/cm <sup>2</sup> , psi
AIR PRESS RR	Rear right tire air pressure value	kPa, kg/cm <sup>2</sup> , psi
BRAKE SW	Brake pedal released	Off
	Brake pedal applied	On
BUCKLE SW	Seat belt buckle unfastened	Off
	Seat belt buckle fastened	On
BUZZER	Buzzer in combination meter OFF	Off
	Buzzer in combination meter ON	On
CARGO LAMP SW	Cargo lamp switch OFF	Off
	Cargo lamp switch ON	On
CDL LOCK SW	Door lock/unlock switch does not operate	Off
	Press door lock/unlock switch to the LOCK side	On
CDL UNLOCK SW	Door lock/unlock switch does not operate	Off
	Press door lock/unlock switch to the UNLOCK side	On
DOOR SW-AS	Front door RH closed	Off
	Front door RH opened	On
DOOR SW-DR	Front door LH closed	Off
	Front door LH opened	On
DOOR SW-RL	Rear door LH closed	Off
	Rear door LH opened	On
DOOR SW-RR	Rear door RH closed	Off
	Rear door RH opened	On
FAN ON SIG	Blower motor fan switch OFF	Off
	Blower motor fan switch ON	On



## BCM (BODY CONTROL MODULE)

### < ECU DIAGNOSIS INFORMATION >

Monitor Item	Condition	Value/Status	
FR FOG SW	Front fog lamp switch OFF	Off	A
	Front fog lamp switch ON	On	
FR WASHER SW	Front washer switch OFF	Off	B
	Front washer switch ON	On	
FR WIPER LOW	Front wiper switch OFF	Off	C
	Front wiper switch LO	On	
FR WIPER HI	Front wiper switch OFF	Off	D
	Front wiper switch HI	On	
FR WIPER INT	Front wiper switch OFF	Off	E
	Front wiper switch INT	On	
FR WIPER STOP	Any position other than front wiper stop position	Off	
	Front wiper stop position	On	
HAZARD SW	When hazard switch is not pressed	Off	F
	When hazard switch is pressed	On	
HEAD LAMP SW 1	Headlamp switch OFF	Off	G
	Headlamp switch 1st	On	
HEAD LAMP SW 2	Headlamp switch OFF	Off	H
	Headlamp switch 1st	On	
HI BEAM SW	High beam switch OFF	Off	I
	High beam switch HI	On	
ID REGST FL1	ID registration of front left tire incomplete	YET	J
	ID registration of front left tire complete	DONE	
ID REGST FR1	ID registration of front right tire incomplete	YET	
	ID registration of front right tire complete	DONE	
ID REGST RL1	ID registration of rear left tire incomplete	YET	
	ID registration of rear left tire complete	DONE	DLK
ID REGST RR1	ID registration of rear right tire incomplete	YET	
	ID registration of rear right tire complete	DONE	
IGN ON SW	Ignition switch OFF or ACC	Off	L
	Ignition switch ON	On	
IGN SW CAN	Ignition switch OFF or ACC	Off	M
	Ignition switch ON	On	
INT VOLUME	Wiper intermittent dial is in a dial position 1 - 7	1 - 7	N
KEY CYL LK-SW	Door key cylinder LOCK position	Off	O
	Door key cylinder other than LOCK position	On	
KEY CYL UN-SW	Door key cylinder UNLOCK position	Off	P
	Door key cylinder other than UNLOCK position	On	
KEY ON SW	Mechanical key is removed from key cylinder	Off	
	Mechanical key is inserted to key cylinder	On	
KEYLESS LOCK	LOCK button of key fob is not pressed	Off	
	LOCK button of key fob is pressed	On	
KEYLESS PANIC	PANIC button of key fob is not pressed	Off	
	PANIC button of key fob is pressed	On	

## BCM (BODY CONTROL MODULE)

### < ECU DIAGNOSIS INFORMATION >

Monitor Item	Condition	Value/Status
KEYLESS UNLOCK	UNLOCK button of key fob is not pressed	Off
	UNLOCK button of key fob is pressed	On
LIGHT SW 1ST	Lighting switch OFF	Off
	Lighting switch 1st	On
OIL PRESS SW	<ul style="list-style-type: none"><li>Ignition switch OFF or ACC</li><li>Engine running</li></ul>	Off
	Ignition switch ON	On
PASSING SW	Other than lighting switch PASS	Off
	Lighting switch PASS	On
REAR DEF SW	Rear window defogger switch OFF	Off
	Rear window defogger switch ON	On
TURN SIGNAL L	Turn signal switch OFF	Off
	Turn signal switch LH	On
TURN SIGNAL R	Turn signal switch OFF	Off
	Turn signal switch RH	On
VEHICLE SPEED	While driving	Equivalent to speedometer reading
WARNING LAMP	Low tire pressure warning lamp in combination meter OFF	Off
	Low tire pressure warning lamp in combination meter ON	On

# BCM (BODY CONTROL MODULE)

< ECU DIAGNOSIS INFORMATION >

## Terminal Layout

INFOID:000000009232915

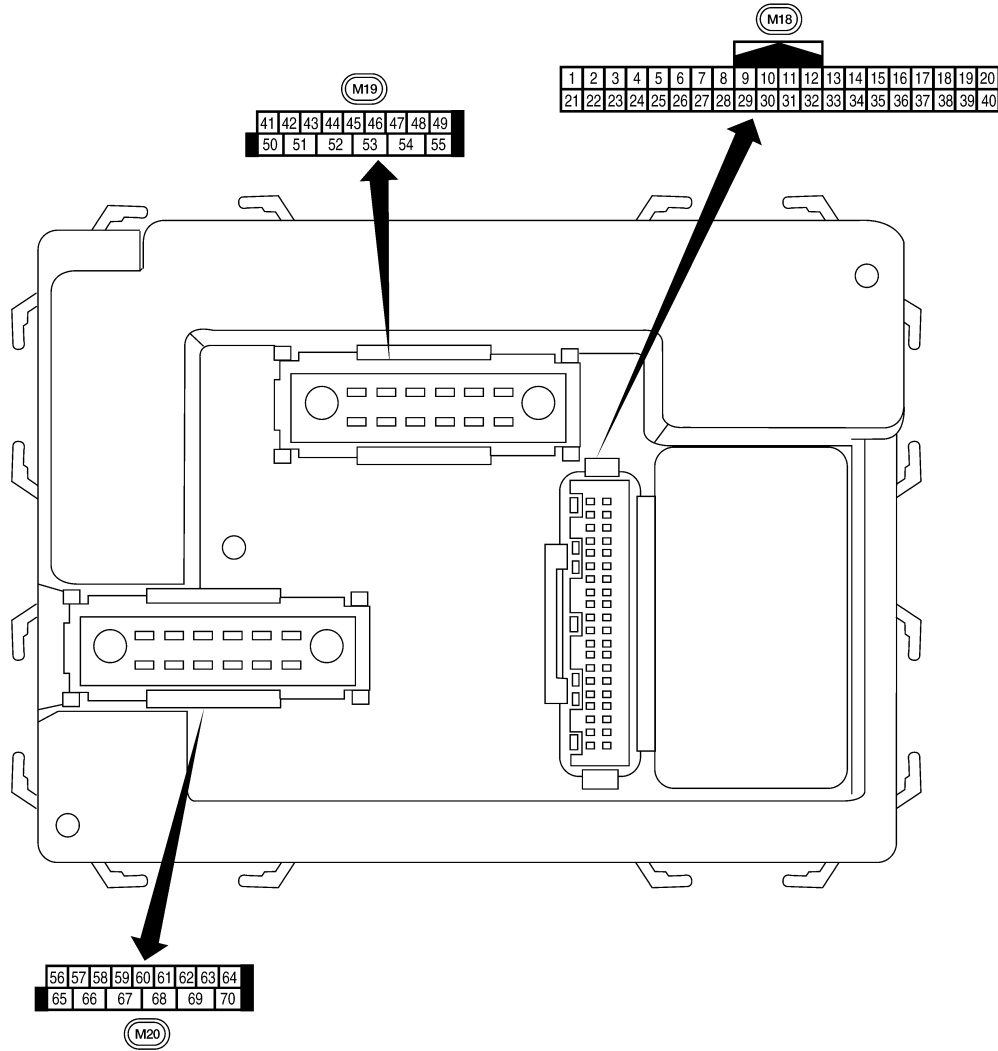

A  
B  
C  
D  
E  
F  
G  
H  
I  
J  
DLK  
L  
M  
N  
O  
P

DLK



LIIA2443E

## Physical Values

INFOID:000000009232916

# BCM (BODY CONTROL MODULE)

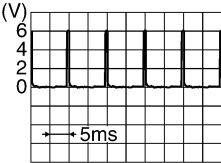
## < ECU DIAGNOSIS INFORMATION >

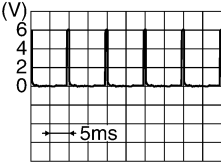
Terminal	Wire color	Item	Signal input/output	Measuring condition		Reference value or waveform (Approx.)
				Ignition switch	Operation or condition	
1	BR	Ignition keyhole illumination	Output	OFF	Door is locked (SW OFF)	Battery voltage
					Door is unlocked (SW ON)	0V
2	P	Combination switch input 5	Input	ON	Lighting, turn, wiper OFF Wiper dial position 4	 <small>SKIA5291E</small>
3	SB	Combination switch input 4	Input	ON	Lighting, turn, wiper OFF Wiper dial position 4	 <small>SKIA5292E</small>
4	V	Combination switch input 3	Input	ON	Lighting, turn, wiper OFF Wiper dial position 4	 <small>SKIA5291E</small>
5	L	Combination switch input 2	Input	ON	Lighting, turn, wiper OFF Wiper dial position 4	 <small>SKIA5292E</small>
6	R	Combination switch input 1				
7	GR	Front door lock assembly LH (key cylinder switch) unlock	Input	OFF	ON (open, 2nd turn)	Momentary 1.5V
8	SB	Front door lock assembly LH (key cylinder switch) lock			OFF (closed)	0V
			On (open)	Momentary 1.5V		
9	LG	Brake sw	Input	OFF	OFF (brake pedal is not depressed)	0V
					ON (brake pedal is depressed)	Battery voltage
11	G/B	Ignition switch (ACC or ON)	Input	ACC or ON	Ignition switch ACC or ON	Battery voltage
12	LG	Front door switch RH (All)	Input	OFF	ON (open)	0V
		Rear door switch upper RH (King Cab)			OFF (closed)	Battery voltage
		Rear door switch lower RH (King Cab)				

# BCM (BODY CONTROL MODULE)

## < ECU DIAGNOSIS INFORMATION >

Terminal	Wire color	Item	Signal input/output	Measuring condition		Reference value or waveform (Approx.)
				Ignition switch	Operation or condition	
13	L	Rear door switch RH (Crew Cab)	Input	OFF	ON (open)	0V
					OFF (closed)	Battery voltage
15	W	Tire pressure warning check connector	Input	OFF	—	5V
18	BR	Remote keyless entry receiver (Ground)	Output	OFF	—	0V
19	V	Remote keyless entry receiver (power supply)	Output	OFF	Ignition switch OFF	
20	G	Remote keyless entry receiver signal (Signal)	Input	OFF	Stand-by (keyfob buttons released)	
					When remote keyless entry receiver receives signal from keyfob (keyfob buttons pressed)	
21	GR	NATS antenna amp.	Input	OFF → ON	Ignition switch (OFF → ON)	Just after turning ignition switch ON: Pointer of tester should move.
23	G	Security indicator lamp	Output	OFF	Goes OFF → illuminates (Every 2.4 seconds)	Battery voltage → 0V
25	BR	NATS antenna amp.	Input	OFF → ON	Ignition switch (OFF → ON)	Just after turning ignition switch ON: Pointer of tester should move.
27	W	Compressor ON signal	Input	ON	A/C switch OFF	5V
					A/C switch ON	0V
28	R	Front blower monitor	Input	ON	Front blower motor OFF	Battery voltage
					Front blower motor ON	0V
29	G	Hazard switch	Input	OFF	ON	0V
					OFF	5V
31	GR	Cargo lamp switch	Input	OFF	ON	0V
					OFF	Battery voltage

A  
B  
C  
D  
E  
F  
G  
H  
I  
J  
DLK  
L  
M  
N  
O  
P

# BCM (BODY CONTROL MODULE)

## < ECU DIAGNOSIS INFORMATION >

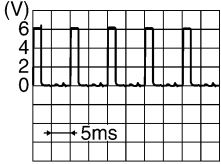
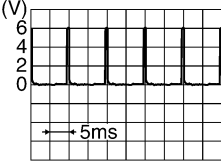
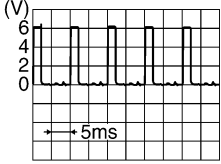
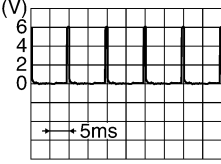
Terminal	Wire color	Item	Signal input/output	Measuring condition		Reference value or waveform (Approx.)
				Ignition switch	Operation or condition	
32	O	Combination switch output 5	Output	ON	Lighting, turn, wiper OFF Wiper dial position 4	 <p style="text-align: right; font-size: small;">SKIA5291E</p>
33	GR	Combination switch output 4	Output	ON	Lighting, turn, wiper OFF Wiper dial position 4	 <p style="text-align: right; font-size: small;">SKIA5292E</p>
34	G	Combination switch output 3	Output	ON	Lighting, turn, wiper OFF Wiper dial position 4	 <p style="text-align: right; font-size: small;">SKIA5291E</p>
35	BR	Combination switch output 2	Output	ON	Lighting, turn, wiper OFF Wiper dial position 4	 <p style="text-align: right; font-size: small;">SKIA5292E</p>
36	LG	Combination switch output 1				
37	B	Key switch	Input	OFF	Key inserted	Battery voltage
					Key removed	0V
38	W/R	Ignition switch (ON)	Input	ON	—	Battery voltage
39	L	CAN-H	—	—	—	—
40	P	CAN-L	—	—	—	—
41	Y	Rear window defogger switch	Input	ON	Rear window defogger switch ON	0V
					Rear window defogger switch OFF	5V
45	V	Lock switch	Input	OFF	ON (lock)	0V
					OFF	Battery voltage
46	LG	Unlock switch	Input	OFF	ON (unlock)	0V
					OFF	Battery voltage
47	GR	Front door switch LH (All)	Input	OFF	ON (open)	0V
		Rear door switch upper LH (King Cab)			OFF (closed)	Battery voltage
		Rear door switch lower LH (King Cab)				

# BCM (BODY CONTROL MODULE)

## < ECU DIAGNOSIS INFORMATION >

Terminal	Wire color	Item	Signal input/output	Measuring condition		Reference value or waveform (Approx.)	
				Ignition switch	Operation or condition		
48	P	Rear door switch LH (Crew Cab)	Input	OFF	ON (open)	0V	
					OFF (closed)	Battery voltage	
50	P	Cargo lamp	Output	OFF	Any door open (ON)	0V	
					All doors closed (OFF)	Battery voltage	
51	O	Trailer turn signal (right)	Output	ON	Turn right ON	<p style="text-align: right; font-size: small;">SKIA3009J</p>	
52	LG	Trailer turn signal (left)	Output	ON	Turn left ON	<p style="text-align: right; font-size: small;">SKIA3009J</p>	
56	R/Y	Battery saver output	Output	OFF	15 minutes after ignition switch is turned OFF	0V	
				ON	—	Battery voltage	
57	R/Y	Battery power supply	Input	—	—	Battery voltage	
58	W	Optical sensor	Input	ON	When optical sensor is illuminated	3.1V or more	
					When optical sensor is not illuminated	0.6V or less	
59	GR	Front door lock assembly LH (unlock)	Output	OFF	OFF (neutral)	0V	
					ON (unlock)	Battery voltage	
60	LG	Turn signal (left)	Output	ON	Turn left ON	<p style="text-align: right; font-size: small;">SKIA3009J</p>	
61	G	Turn signal (right)	Output	ON	Turn right ON	<p style="text-align: right; font-size: small;">SKIA3009J</p>	
63	BR	Interior room/map lamp	Output	OFF	Any door switch	ON (open)	0V
					OFF (closed)	Battery voltage	
65	V	All door lock actuators (lock)	Output	OFF	OFF (neutral)	0V	
					ON (lock)	Battery voltage	

A  
B  
C  
D  
E  
F  
G  
H  
I  
J  
DLK  
L  
M  
N  
O  
P

# BCM (BODY CONTROL MODULE)

## < ECU DIAGNOSIS INFORMATION >

Terminal	Wire color	Item	Signal input/output	Measuring condition		Reference value or waveform (Approx.)
				Ignition switch	Operation or condition	
66	L	Front door lock actuator RH, rear door lock actuators LH/RH (unlock)	Output	OFF	OFF (neutral)	0V
					ON (unlock)	Battery voltage
67	B	Ground	Input	ON	—	0V
68 <sup>1</sup>	O	Power window power supply (RAP)	Output	—	Ignition switch ON	Battery voltage
					Within 45 seconds after ignition switch OFF	Battery voltage
					More than 45 seconds after ignition switch OFF	0V
					When front door LH or RH is open or power window timer operates	0V
68 <sup>2</sup>	SB	Power window power supply (RAP)	Output	—	Ignition switch ON	Battery voltage
					Within 45 seconds after ignition switch OFF	Battery voltage
					More than 45 seconds after ignition switch OFF	0V
					When front door LH or RH is open or power window timer operates	0V
69	P	Power window power supply (BAT)	Output	OFF	—	Battery voltage
70	W	Battery power supply	Input	OFF	—	Battery voltage

1: King cab (with power door lock system)

2: Crew cab (without power door lock system)

## Fail Safe

INFOID:000000009232917

### Fail-safe index

BCM performs fail-safe control when any DTC listed below is detected.

Display contents of CONSULT	Fail-safe	Cancellation
U1000: CAN COMM CIRCUIT	Inhibit engine cranking	When the BCM re-establishes communication with the other modules.

## DTC Inspection Priority Chart

INFOID:000000009232918

If some DTCs are displayed at the same time, perform inspections one by one based on the following priority chart.

Priority	DTC
1	<ul style="list-style-type: none"> <li>U1000: CAN COMM CIRCUIT</li> </ul>
2	<ul style="list-style-type: none"> <li>B2190: NATS ANTENNA AMP</li> <li>B2191: DIFFERENCE OF KEY</li> <li>B2192: ID DISCORD BCM-ECM</li> <li>B2193: CHAIN OF BCM-ECM</li> </ul>



# BCM (BODY CONTROL MODULE)

## < ECU DIAGNOSIS INFORMATION >

Priority	DTC	
3	<ul style="list-style-type: none"> <li>• C1729: VHCL SPEED SIG ERR</li> <li>• C1735: IGNITION SIGNAL</li> </ul>	A
4	<ul style="list-style-type: none"> <li>• C1704: LOW PRESSURE FL</li> <li>• C1705: LOW PRESSURE FR</li> <li>• C1706: LOW PRESSURE RR</li> <li>• C1707: LOW PRESSURE RL</li> <li>• C1708: [NO DATA] FL</li> <li>• C1709: [NO DATA] FR</li> <li>• C1710: [NO DATA] RR</li> <li>• C1711: [NO DATA] RL</li> <li>• C1712: [CHECKSUM ERR] FL</li> <li>• C1713: [CHECKSUM ERR] FR</li> <li>• C1714: [CHECKSUM ERR] RR</li> <li>• C1715: [CHECKSUM ERR] RL</li> <li>• C1716: [PRESSDATA ERR] FL</li> <li>• C1717: [PRESSDATA ERR] FR</li> <li>• C1718: [PRESSDATA ERR] RR</li> <li>• C1719: [PRESSDATA ERR] RL</li> <li>• C1720: [CODE ERR] FL</li> <li>• C1721: [CODE ERR] FR</li> <li>• C1722: [CODE ERR] RR</li> <li>• C1723: [CODE ERR] RL</li> <li>• C1724: [BATT VOLT LOW] FL</li> <li>• C1725: [BATT VOLT LOW] FR</li> <li>• C1726: [BATT VOLT LOW] RR</li> <li>• C1727: [BATT VOLT LOW] RL</li> </ul>	B C D E F G H

## DTC Index

INFOID:000000009232919

### NOTE:

- Details of time display
- CRNT: Displays when there is a malfunction now or after returning to the normal condition until turning ignition switch OFF → ON again.
- 1 - 39: Displayed if any previous malfunction is present when current condition is normal. It increases like 1 → 2 → 3...38 → 39 after returning to the normal condition whenever ignition switch OFF → ON. The counter remains at 39 even if the number of cycles exceeds it. It is counted from 1 again when turning ignition switch OFF → ON after returning to the normal condition if the malfunction is detected again.

CONSULT display	Fail-safe	Low tire pressure warning lamp ON	Reference page
No DTC is detected. further testing may be required.	—	—	—
U1000: CAN COMM CIRCUIT	—	—	<a href="#">BCS-26</a>
B2190: NATS ANTENA AMP	—	—	<a href="#">SEC-18</a>
B2191: DIFFERENCE OF KEY	—	—	<a href="#">SEC-21</a>
B2192: ID DISCORD BCM-ECM	—	—	<a href="#">SEC-22</a>
B2193: CHAIN OF BCM-ECM	—	—	<a href="#">SEC-24</a>
C1708: [NO DATA] FL	—	X	<a href="#">WT-15</a>
C1709: [NO DATA] FR	—	X	<a href="#">WT-15</a>
C1710: [NO DATA] RR	—	X	<a href="#">WT-15</a>
C1711: [NO DATA] RL	—	X	<a href="#">WT-15</a>
C1712: [CHECKSUM ERR] FL	—	X	<a href="#">WT-17</a>
C1713: [CHECKSUM ERR] FR	—	X	<a href="#">WT-17</a>
C1714: [CHECKSUM ERR] RR	—	X	<a href="#">WT-17</a>
C1715: [CHECKSUM ERR] RL	—	X	<a href="#">WT-17</a>

A  
B  
C  
D  
E  
F  
G  
H  
I  
J  
DLK

## BCM (BODY CONTROL MODULE)

### < ECU DIAGNOSIS INFORMATION >

CONSULT display	Fail-safe	Low tire pressure warning lamp ON	Reference page
C1716: [PRESSDATA ERR] FL	—	X	<a href="#">WT-19</a>
C1717: [PRESSDATA ERR] FR	—	X	<a href="#">WT-19</a>
C1718: [PRESSDATA ERR] RR	—	X	<a href="#">WT-19</a>
C1719: [PRESSDATA ERR] RL	—	X	<a href="#">WT-19</a>
C1720: [CODE ERR] FL	—	X	<a href="#">WT-17</a>
C1721: [CODE ERR] FR	—	X	<a href="#">WT-17</a>
C1722: [CODE ERR] RR	—	X	<a href="#">WT-17</a>
C1723: [CODE ERR] RL	—	X	<a href="#">WT-17</a>
C1724: [BATT VOLT LOW] FL	—	X	<a href="#">WT-17</a>
C1725: [BATT VOLT LOW] FR	—	X	<a href="#">WT-17</a>
C1726: [BATT VOLT LOW] RR	—	X	<a href="#">WT-17</a>
C1727: [BATT VOLT LOW] RL	—	X	<a href="#">WT-17</a>
C1729: VHCL SPEED SIG ERR	—	X	<a href="#">WT-21</a>
C1735: IGNITION SIGNAL	—	X	<a href="#">WT-22</a>

# INTEGRATED HOMELINK TRANSMITTER

< WIRING DIAGRAM >

## WIRING DIAGRAM

### INTEGRATED HOMELINK TRANSMITTER

Wiring Diagram

INFOID:000000008792322

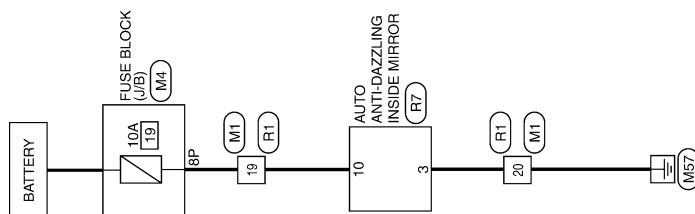

INTEGRATED HOMELINK TRANSMITTER

DLK

AWKWA0054GB

# INTEGRATED HOMELINK TRANSMITTER

< WIRING DIAGRAM >

## INTEGRATED HOMELINK TRANSMITTER CONNECTORS

Connector No.	M1
Connector Name	WIRE TO WIRE
Connector Color	WHITE

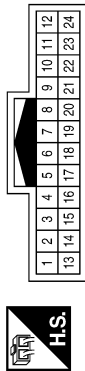

Terminal No.	Color of Wire	Signal Name
19	R/Y	-
20	B	-

Connector No.	M4
Connector Name	FUSE BLOCK (J/B)
Connector Color	WHITE

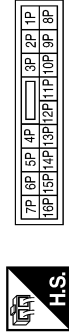

Terminal No.	Color of Wire	Signal Name
8P	R/Y	-

Connector No.	R1
Connector Name	WIRE TO WIRE
Connector Color	WHITE

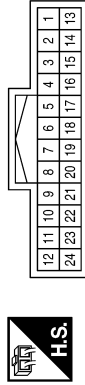

Terminal No.	Color of Wire	Signal Name
19	R/Y	-
20	B	-

Connector No.	R7
Connector Name	AUTO ANTI-DAZZLING INSIDE MIRROR (WITH HOMELINK UNIVERSAL TRANSCIEVER)
Connector Color	BLACK

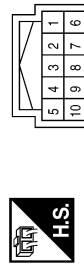

Terminal No.	Color of Wire	Signal Name
3	B	-
10	R/Y	-

ABKIA4346GB

# POWER DOOR LOCK SYSTEM

< WIRING DIAGRAM >

## POWER DOOR LOCK SYSTEM

Wiring Diagram - King Cab

INFOID:000000008792323

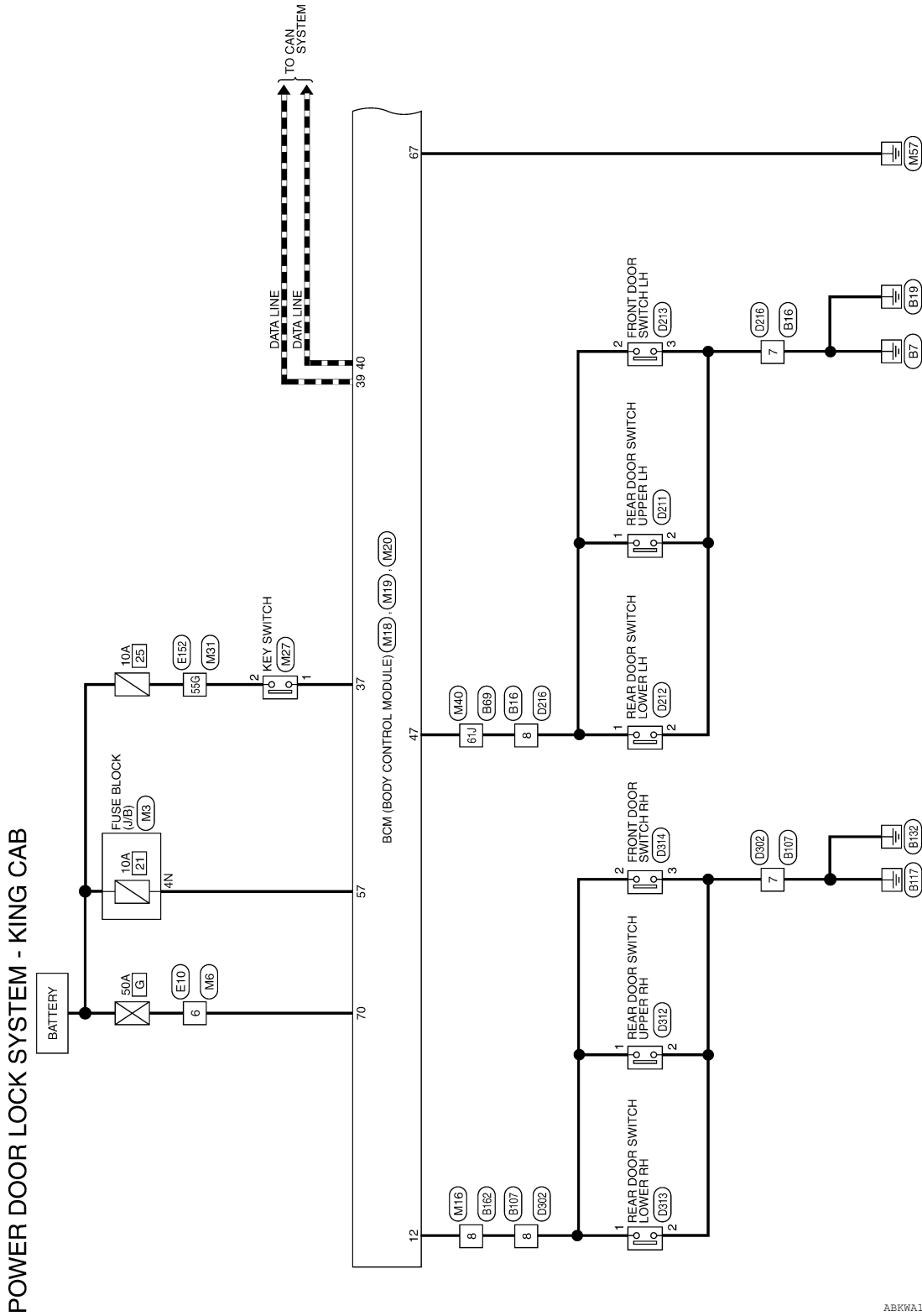

ABKWA1567GB

A  
B  
C  
D  
E  
F  
G  
H  
I  
J  
DLK  
L  
M  
N  
O  
P

# POWER DOOR LOCK SYSTEM

< WIRING DIAGRAM >

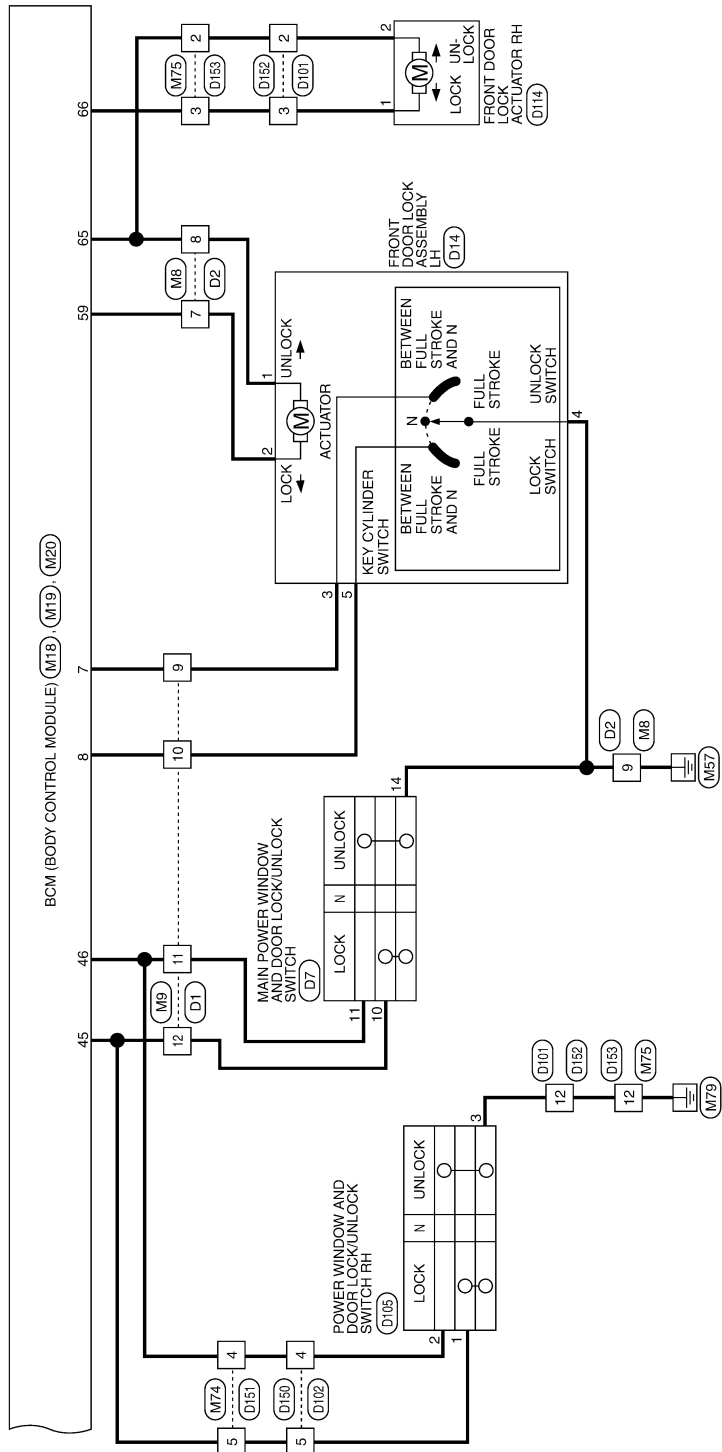

ABKWA1994GB

# POWER DOOR LOCK SYSTEM

< WIRING DIAGRAM >

## POWER DOOR LOCK SYSTEM CONNECTORS - KING CAB

Connector No.	M3
Connector Name	FUSE BLOCK (J/B)
Connector Color	WHITE

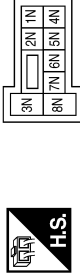

Terminal No.	Color of Wire	Signal Name
4N	R/Y	-

Connector No.	M6
Connector Name	WIRE TO WIRE
Connector Color	WHITE



Terminal No.	Color of Wire	Signal Name
6	W	-

Connector No.	M8
Connector Name	WIRE TO WIRE
Connector Color	BROWN

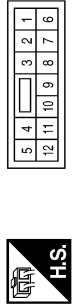

Terminal No.	Color of Wire	Signal Name
7	GR	-
8	V	-
9	B	-

Connector No.	M9
Connector Name	WIRE TO WIRE
Connector Color	WHITE

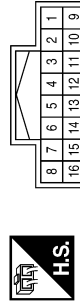

Terminal No.	Color of Wire	Signal Name
9	GR	-
10	SB	-
11	LG	-
12	V	-

Connector No.	M16
Connector Name	WIRE TO WIRE
Connector Color	WHITE

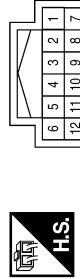



Terminal No.	Color of Wire	Signal Name
8	LG	-

A  
B  
C  
D  
E  
F  
G  
H  
I  
J  
DLK  
L  
M  
N  
O  
P

# POWER DOOR LOCK SYSTEM

< WIRING DIAGRAM >

Connector No.	M19
Connector Name	BCM (BODY CONTROL MODULE)
Connector Color	WHITE

Terminal No.	Color of Wire	Signal Name
45	V	CDL LOCK SW
46	LG	CDL UNLOCK SW
47	GR	DOOR SW (DR)

Terminal No.	Color of Wire	Signal Name
7	GR	KEY CYLINDER UNLOCK SW
8	SB	KEY CYLINDER LOCK SW
12	LG	DOOR SW (AS)
37	B	KEY SW
39	L	CAN-H
40	P	CAN-L

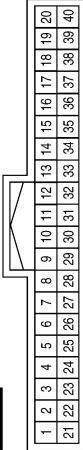

Connector No.	M18
Connector Name	BCM (BODY CONTROL MODULE)
Connector Color	WHITE

Connector No.	M27
Connector Name	KEY SWITCH
Connector Color	WHITE



Connector No.	M20
Connector Name	BCM (BODY CONTROL MODULE)
Connector Color	BLACK

Terminal No.	Color of Wire	Signal Name
1	B	-
2	Y	-

Terminal No.	Color of Wire	Signal Name
57	R/Y	BAT (FUSE)
59	GR	DOOR UNLOCK OUTPUT (DR)
65	V	DOOR LOCK OUTPUT (ALL)
66	L	DOOR UNLOCK OUTPUT (OTHER)
67	B	GND (POWER)
70	W	BAT (F/L)

ABK1A1839GB



# POWER DOOR LOCK SYSTEM

< WIRING DIAGRAM >

Connector No.	M74
Connector Name	WIRE TO WIRE
Connector Color	WHITE

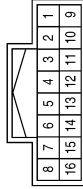

Terminal No.	Color of Wire	Signal Name
4	LG	-
5	P	-

Connector No.	M40
Connector Name	WIRE TO WIRE
Connector Color	WHITE

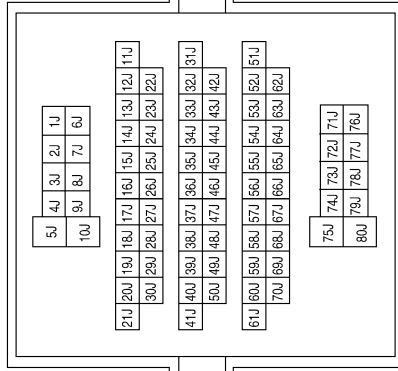

Terminal No.	Color of Wire	Signal Name
61J	GR	-

Connector No.	M31
Connector Name	WIRE TO WIRE
Connector Color	WHITE

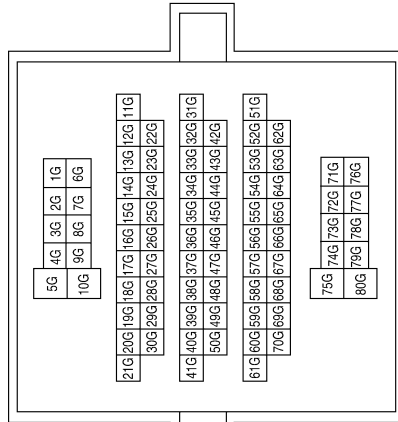

Terminal No.	Color of Wire	Signal Name
55G	Y	-

Connector No.	E10
Connector Name	WIRE TO WIRE
Connector Color	WHITE



Terminal No.	Color of Wire	Signal Name
6	W	-

Connector No.	M75
Connector Name	WIRE TO WIRE
Connector Color	WHITE

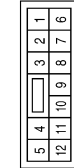

Terminal No.	Color of Wire	Signal Name
2	V	-
3	L	-
12	B	-

ABKIA0504GB

A  
B  
C  
D  
E  
F  
G  
H  
I  
J  
K  
L  
M  
N  
O  
P

DLK

# POWER DOOR LOCK SYSTEM

< WIRING DIAGRAM >

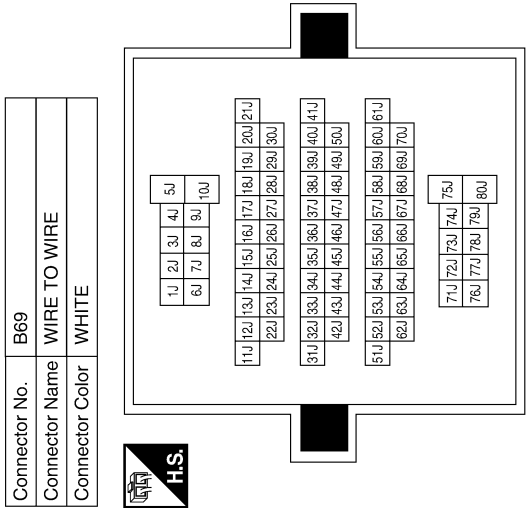

Terminal No.	Color of Wire	Signal Name
61J	GR	-



Terminal No.	Color of Wire	Signal Name
7	B	-
8	GR	-

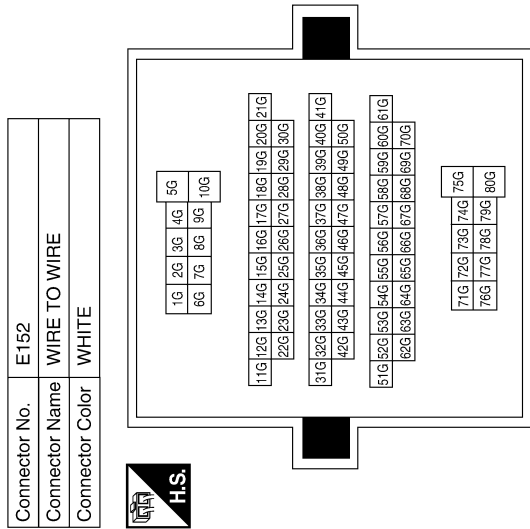

Terminal No.	Color of Wire	Signal Name
55G	Y	-



Terminal No.	Color of Wire	Signal Name
9	R/W	-
10	SB	-
11	W	-
12	LG	-



Terminal No.	Color of Wire	Signal Name
8	LG	-



Terminal No.	Color of Wire	Signal Name
7	B	-
8	LG	-

ABKIA0505GB

# POWER DOOR LOCK SYSTEM

< WIRING DIAGRAM >

Connector No.	D2
Connector Name	WIRE TO WIRE
Connector Color	BROWN

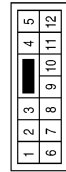

Terminal No.	Color of Wire	Signal Name
7	G	-
8	V	-
9	B	-

Connector No.	D7
Connector Name	MAIN POWER WINDOW AND DOOR LOCK/UNLOCK SWITCH
Connector Color	WHITE

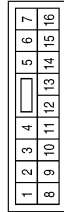

Terminal No.	Color of Wire	Signal Name
10	LG	-
11	W	-
14	B	-

Connector No.	D14
Connector Name	FRONT DOOR LOCK ASSEMBLY LH
Connector Color	GRAY

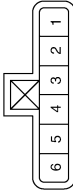

Terminal No.	Color of Wire	Signal Name
1	V	-
2	G	-
3	R/W	-
4	B	-
5	SB	-

Connector No.	D101
Connector Name	WIRE TO WIRE
Connector Color	WHITE

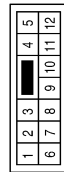

Terminal No.	Color of Wire	Signal Name
2	V	-
3	G/Y	-
12	B	-

Connector No.	D102
Connector Name	WIRE TO WIRE
Connector Color	WHITE

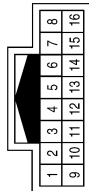

Terminal No.	Color of Wire	Signal Name
4	W	-
5	LG	-

Connector No.	D105
Connector Name	POWER WINDOW AND DOOR LOCK/UNLOCK SWITCH RH
Connector Color	WHITE

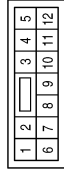

Terminal No.	Color of Wire	Signal Name
1	LG	-
2	W	-
3	B	-

ABKIA0580GB

A  
B  
C  
D  
E  
F  
G  
H  
I  
J  
K  
L  
M  
N  
O  
P

DLK

# POWER DOOR LOCK SYSTEM

< WIRING DIAGRAM >

Connector No.	D151
Connector Name	WIRE TO WIRE
Connector Color	WHITE

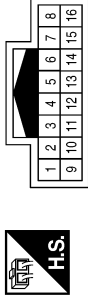

Terminal No.	Color of Wire	Signal Name
4	LG	-(WITH KING CAB)
5	P	-(WITH KING CAB)

Connector No.	D150
Connector Name	WIRE TO WIRE
Connector Color	WHITE

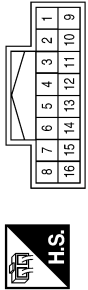

Terminal No.	Color of Wire	Signal Name
4	LG	-(WITH KING CAB)
5	P	-(WITH KING CAB)

Connector No.	D114
Connector Name	FRONT DOOR LOCK ACTUATOR RH
Connector Color	BROWN



Terminal No.	Color of Wire	Signal Name
1	G/Y	-
2	V	-

Connector No.	D211
Connector Name	REAR DOOR SWITCH UPPER LH
Connector Color	BLACK



Terminal No.	Color of Wire	Signal Name
1	L	-
2	B	-

Connector No.	D153
Connector Name	WIRE TO WIRE
Connector Color	WHITE

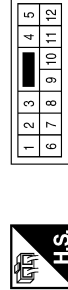

Terminal No.	Color of Wire	Signal Name
2	V	-
3	L	-
12	B	-

Connector No.	D152
Connector Name	WIRE TO WIRE
Connector Color	WHITE



Terminal No.	Color of Wire	Signal Name
2	V	-
3	L	-
12	B	-

ABKIA4349GB

# POWER DOOR LOCK SYSTEM

< WIRING DIAGRAM >

Connector No.	D216
Connector Name	WIRE TO WIRE
Connector Color	WHITE

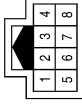

Terminal No.	Color of Wire	Signal Name
7	B	-
8	LG	-

Connector No.	D213
Connector Name	FRONT DOOR SWITCH LH (KING CAB)
Connector Color	WHITE

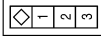

Terminal No.	Color of Wire	Signal Name
2	LG	-
3	B	-

Connector No.	D212
Connector Name	REAR DOOR SWITCH LOWER LH
Connector Color	BLACK



Terminal No.	Color of Wire	Signal Name
1	L	-
2	B	-

Connector No.	D313
Connector Name	REAR DOOR SWITCH LOWER RH
Connector Color	BLACK



Terminal No.	Color of Wire	Signal Name
1	L	-
2	B	-

Connector No.	D312
Connector Name	REAR DOOR SWITCH UPPER RH
Connector Color	BLACK



Terminal No.	Color of Wire	Signal Name
1	L	-
2	B	-

Connector No.	D302
Connector Name	WIRE TO WIRE
Connector Color	WHITE



Terminal No.	Color of Wire	Signal Name
7	B	-
8	LG	-

ABKIA4350GB

A  
B  
C  
D  
E  
F  
G  
H  
I  
J  
DLK  
L  
M  
N  
O  
P

# POWER DOOR LOCK SYSTEM

< WIRING DIAGRAM >

---

Connector No.	D314
Connector Name	FRONT DOOR SWITCH RH (KING CAB)
Connector Color	WHITE

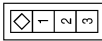

Terminal No.	Color of Wire	Signal Name
2	LG	-
3	B	-

ABKIA4360GB

# POWER DOOR LOCK SYSTEM

< WIRING DIAGRAM >

## Wiring Diagram - Crew Cab

INFOID:000000008792324

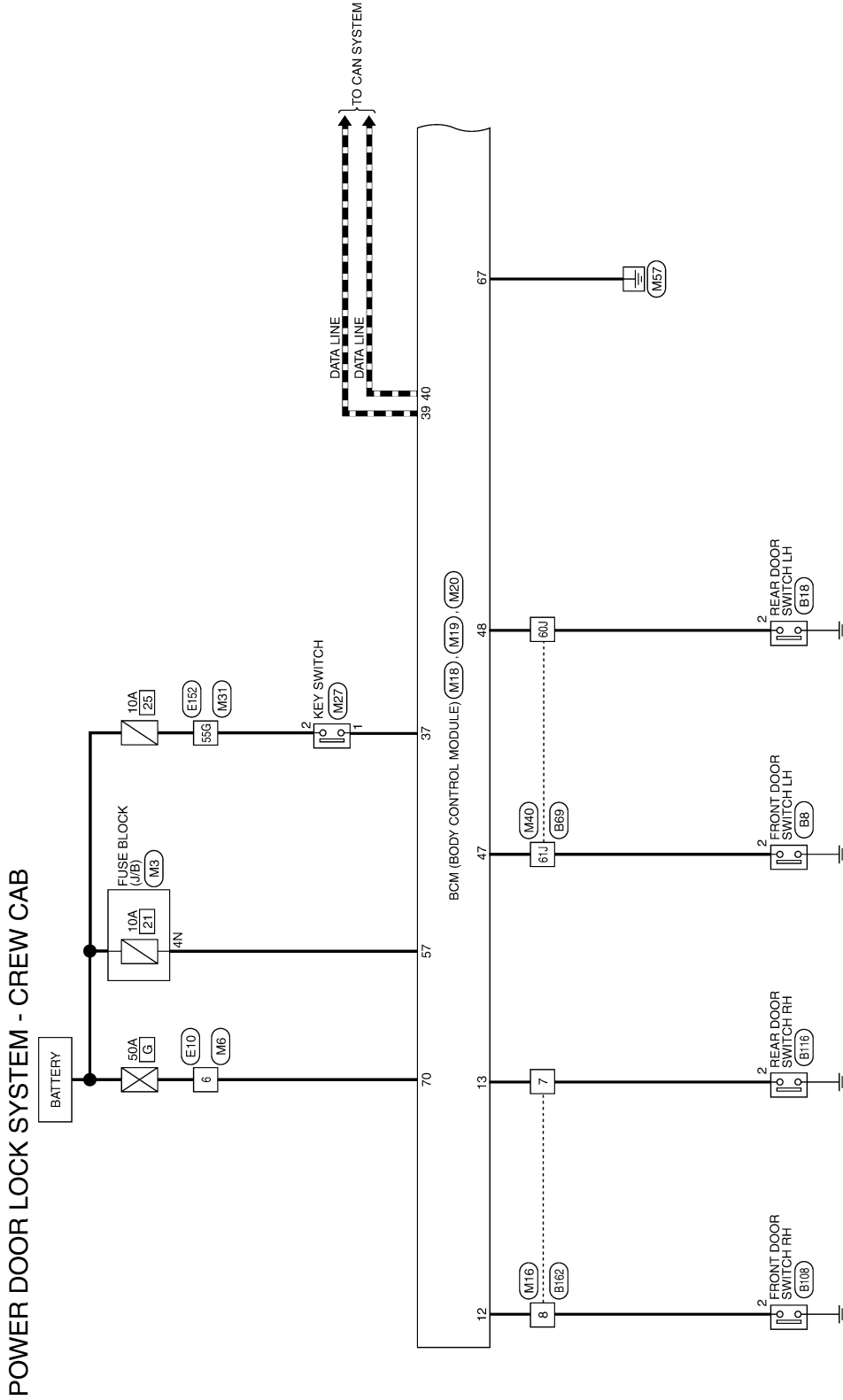

A  
B  
C  
D  
E  
F  
G  
H  
I  
J  
DLK  
L  
M  
N  
O  
P

# POWER DOOR LOCK SYSTEM

< WIRING DIAGRAM >

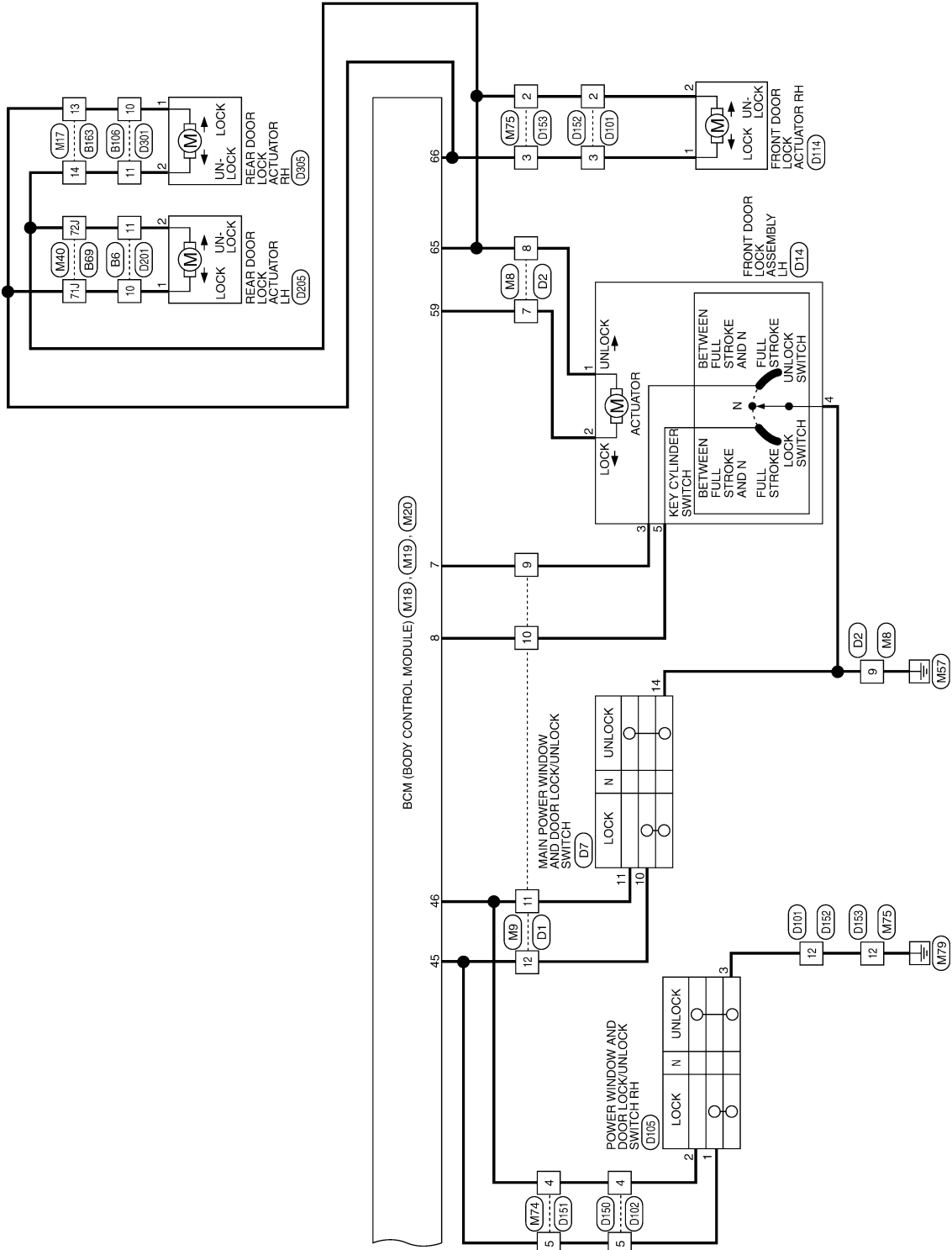

ABKWA1993GB



# POWER DOOR LOCK SYSTEM

< WIRING DIAGRAM >

## POWER DOOR LOCK SYSTEM CONNECTORS - CREW CAB

Connector No.	M3
Connector Name	FUSE BLOCK (J/B)
Connector Color	WHITE

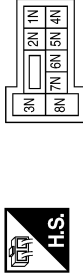

Terminal No.	Color of Wire	Signal Name
4N	R/Y	-

Connector No.	M6
Connector Name	WIRE TO WIRE
Connector Color	WHITE



Terminal No.	Color of Wire	Signal Name
6	W	-

Connector No.	M8
Connector Name	WIRE TO WIRE
Connector Color	BROWN

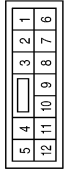

Terminal No.	Color of Wire	Signal Name
7	GR	-
8	V	-
9	B	-

Connector No.	M9
Connector Name	WIRE TO WIRE
Connector Color	WHITE

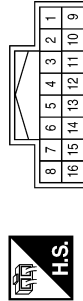

Terminal No.	Color of Wire	Signal Name
9	GR	-
10	SB	-
11	LG	-
12	V	-

Connector No.	M16
Connector Name	WIRE TO WIRE
Connector Color	WHITE

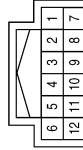

Terminal No.	Color of Wire	Signal Name
7	L	-
8	LG	-

Connector No.	M17
Connector Name	WIRE TO WIRE
Connector Color	WHITE

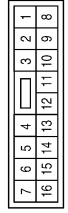

Terminal No.	Color of Wire	Signal Name
13	SB	-
14	V	-

ABKIA0669GB

A  
B  
C  
D  
E  
F  
G  
H  
I  
J  
DLK  
L  
M  
N  
O  
P

# POWER DOOR LOCK SYSTEM

< WIRING DIAGRAM >

Connector No.	M19
Connector Name	BCM (BODY CONTROL MODULE)
Connector Color	WHITE



41	42	43	44	45	46	47	48	49
50	51	52	53	54	55			

Terminal No.	Color of Wire	Signal Name
45	V	CDL LOCK SW
46	LG	CDL UNLOCK SW
47	GR	DOOR SW (DR)
48	P	DOOR SW (RL)

Terminal No.	Color of Wire	Signal Name
7	GR	KEY CYLINDER UNLOCK SW
8	SB	KEY CYLINDER LOCK SW
12	LG	DOOR SW (AS)
13	L	DOOR SW (RR)
37	B	KEY SW
39	L	CAN-H
40	P	CAN-L

Connector No.	M18
Connector Name	BCM (BODY CONTROL MODULE)
Connector Color	WHITE



1	2	3	4	5	6	7	8	9	10	11	12	13	14	15	16	17	18	19	20
21	22	23	24	25	26	27	28	29	30	31	32	33	34	35	36	37	38	39	40

Connector No.	M27
Connector Name	KEY SWITCH
Connector Color	WHITE



2	1
---	---

Terminal No.	Color of Wire	Signal Name
1	B	-
2	Y	-

Connector No.	M20
Connector Name	BCM (BODY CONTROL MODULE)
Connector Color	BLACK



56	57	58	59	60	61	62	63	64
65	66	67	68	69	70			

Terminal No.	Color of Wire	Signal Name
57	R/Y	BAT (FUSE)
59	GR	DOOR UNLOCK OUTPUT (DR)
65	V	DOOR LOCK OUTPUT (ALL)
66	L	DOOR UNLOCK OUTPUT (OTHER)
67	B	GND (POWER)
70	W	BAT (F/L)

ABK1A1841GB

# POWER DOOR LOCK SYSTEM

< WIRING DIAGRAM >

Terminal No.	Color of Wire	Signal Name
60J	P	-
61J	GR	-
71J	L	-
72J	V	-

Connector No.	M40
Connector Name	WIRE TO WIRE
Connector Color	WHITE

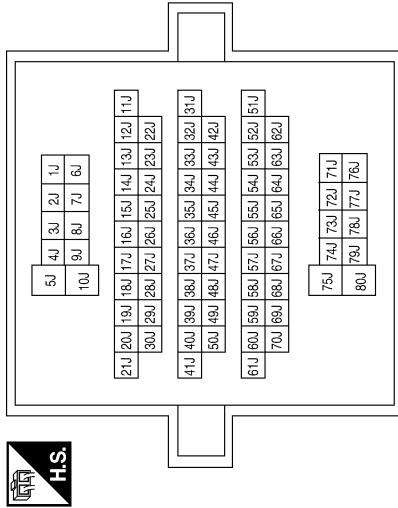

Connector No.	M31
Connector Name	WIRE TO WIRE
Connector Color	WHITE

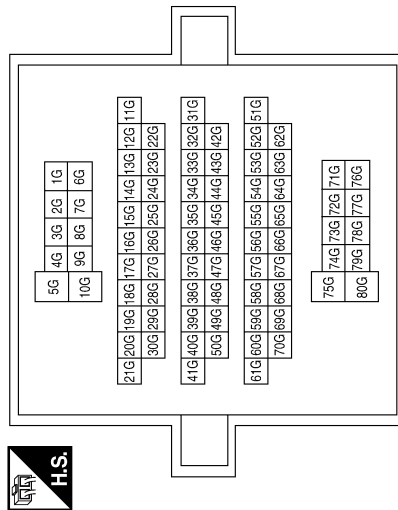

Terminal No.	Color of Wire	Signal Name
55G	Y	-

Connector No.	E10
Connector Name	WIRE TO WIRE
Connector Color	WHITE



Terminal No.	Color of Wire	Signal Name
6	W	-

Connector No.	M75
Connector Name	WIRE TO WIRE
Connector Color	WHITE

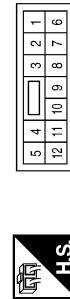

Terminal No.	Color of Wire	Signal Name
2	V	-
3	L	-
12	B	-

Connector No.	M74
Connector Name	WIRE TO WIRE
Connector Color	WHITE

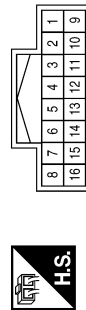

Terminal No.	Color of Wire	Signal Name
4	LG	-
5	P	-

ABKIA0509GB

A B C D E F G H I J L M N O P

DLK

# POWER DOOR LOCK SYSTEM

< WIRING DIAGRAM >

Connector No.	B6
Connector Name	WIRE TO WIRE
Connector Color	WHITE

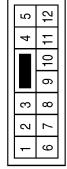

Terminal No.	Color of Wire	Signal Name
10	L	-
11	V	-

Terminal No.	55G	Color of Wire	Y	Signal Name	-
--------------	-----	---------------	---	-------------	---

Connector No.	E152
Connector Name	WIRE TO WIRE
Connector Color	WHITE

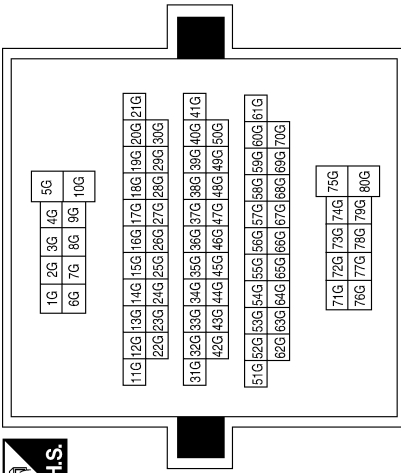

Connector No.	B18
Connector Name	REAR DOOR SWITCH LH
Connector Color	WHITE

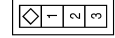

Terminal No.	2	Color of Wire	P	Signal Name	-
--------------	---	---------------	---	-------------	---

Connector No.	B8
Connector Name	FRONT DOOR SWITCH LH (CREW CAB)
Connector Color	WHITE

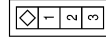

Terminal No.	2	Color of Wire	GR	Signal Name	-
--------------	---	---------------	----	-------------	---

ABKIA0510GB

# POWER DOOR LOCK SYSTEM

< WIRING DIAGRAM >

Connector No.	B69
Connector Name	WIRE TO WIRE
Connector Color	WHITE

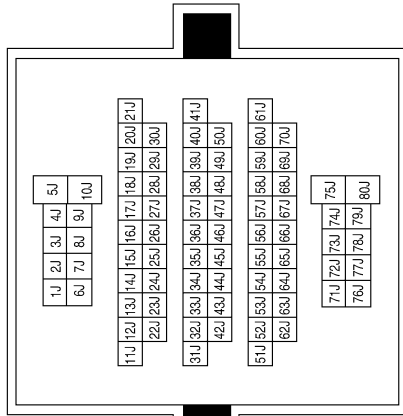

Terminal No.	Color of Wire	Signal Name
60J	P	-
61J	GR	-
71J	L	-
72J	V	-

Connector No.	B106
Connector Name	WIRE TO WIRE
Connector Color	WHITE

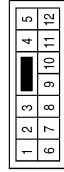

Terminal No.	Color of Wire	Signal Name
10	SB	-
11	V	-

Connector No.	B108
Connector Name	FRONT DOOR SWITCH RH (CREW CAB)
Connector Color	WHITE



Terminal No.	Color of Wire	Signal Name
2	LG	-

Connector No.	B116
Connector Name	REAR DOOR SWITCH RH
Connector Color	WHITE



Terminal No.	Color of Wire	Signal Name
2	L	-

Connector No.	B162
Connector Name	WIRE TO WIRE
Connector Color	WHITE

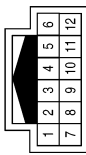

Terminal No.	Color of Wire	Signal Name
7	L	-
8	LG	-

A  
B  
C  
D  
E  
F  
G  
H  
I  
J  
K  
L  
M  
N  
O  
P

DLK

ABKIA0511GB

# POWER DOOR LOCK SYSTEM

< WIRING DIAGRAM >

Connector No.	B163
Connector Name	WIRE TO WIRE
Connector Color	WHITE

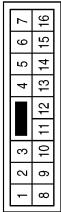

Terminal No.	Color of Wire	Signal Name
13	SB	-
14	V	-

Connector No.	D1
Connector Name	WIRE TO WIRE
Connector Color	WHITE

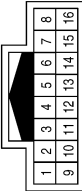

Terminal No.	Color of Wire	Signal Name
9	R/W	-
10	SB	-
11	W	-
12	LG	-

Connector No.	D2
Connector Name	WIRE TO WIRE
Connector Color	BROWN

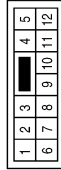

Terminal No.	Color of Wire	Signal Name
7	G	-
8	V	-
9	B	-

Connector No.	D7
Connector Name	MAIN POWER WINDOW AND DOOR LOCK/UNLOCK SWITCH
Connector Color	WHITE

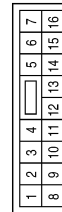

Terminal No.	Color of Wire	Signal Name
10	LG	-
11	W	-
14	B	-

Connector No.	D14
Connector Name	FRONT DOOR LOCK ASSEMBLY LH
Connector Color	GRAY

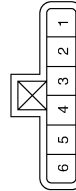

Terminal No.	Color of Wire	Signal Name
1	V	-
2	G	-
3	R/W	-
4	B	-
5	SB	-

Connector No.	D101
Connector Name	WIRE TO WIRE
Connector Color	WHITE

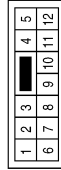

Terminal No.	Color of Wire	Signal Name
2	V	-
3	G/Y	-
12	B	-

# POWER DOOR LOCK SYSTEM

< WIRING DIAGRAM >

Connector No.	D102
Connector Name	WIRE TO WIRE
Connector Color	WHITE

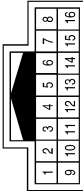

Terminal No.	Color of Wire	Signal Name
4	W	-
5	LG	-

Connector No.	D105
Connector Name	POWER WINDOW AND DOOR LOCK/UNLOCK SWITCH RH
Connector Color	WHITE

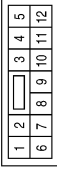
Terminal No.	Color of Wire	Signal Name
1	LG	-
2	W	-
3	B	-

Connector No.	D114
Connector Name	FRONT DOOR LOCK ACTUATOR RH
Connector Color	BROWN

Terminal No.	Color of Wire	Signal Name
1	G/Y	-
2	V	-

Connector No.	D150
Connector Name	WIRE TO WIRE
Connector Color	WHITE



Terminal No.	Color of Wire	Signal Name
4	P	-(WITH CREW CAB)
5	W	-(WITH CREW CAB)

Connector No.	D151
Connector Name	WIRE TO WIRE
Connector Color	WHITE



Terminal No.	Color of Wire	Signal Name
4	P	-(WITH CREW CAB)
5	W	-(WITH CREW CAB)

Connector No.	D152
Connector Name	WIRE TO WIRE
Connector Color	WHITE



Terminal No.	Color of Wire	Signal Name
2	V	-
3	L	-
12	B	-

ABKIA4347GB

A  
B  
C  
D  
E  
F  
G  
H  
I  
J  
DLK  
L  
M  
N  
O  
P

# POWER DOOR LOCK SYSTEM

< WIRING DIAGRAM >

Connector No.	D205
Connector Name	REAR DOOR LOCK ACTUATOR LH
Connector Color	BROWN



Terminal No.	Color of Wire	Signal Name
1	G	-
2	V	-

Connector No.	D201
Connector Name	WIRE TO WIRE
Connector Color	WHITE

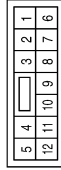

Terminal No.	Color of Wire	Signal Name
10	G	-
11	V	-

Connector No.	D153
Connector Name	WIRE TO WIRE
Connector Color	WHITE

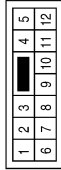

Terminal No.	Color of Wire	Signal Name
2	V	-
3	L	-
12	B	-

Connector No.	D305
Connector Name	REAR DOOR LOCK ACTUATOR RH
Connector Color	BROWN



Terminal No.	Color of Wire	Signal Name
1	G	-
2	V	-

Connector No.	D301
Connector Name	WIRE TO WIRE
Connector Color	WHITE

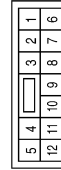

Terminal No.	Color of Wire	Signal Name
10	G	-
11	V	-

ABKIA4348GB



# REMOTE KEYLESS ENTRY SYSTEM

< WIRING DIAGRAM >

## REMOTE KEYLESS ENTRY SYSTEM

Wiring Diagram - King Cab

INFOID:000000008792325

### REMOTE KEYLESS ENTRY SYSTEM - KING CAB

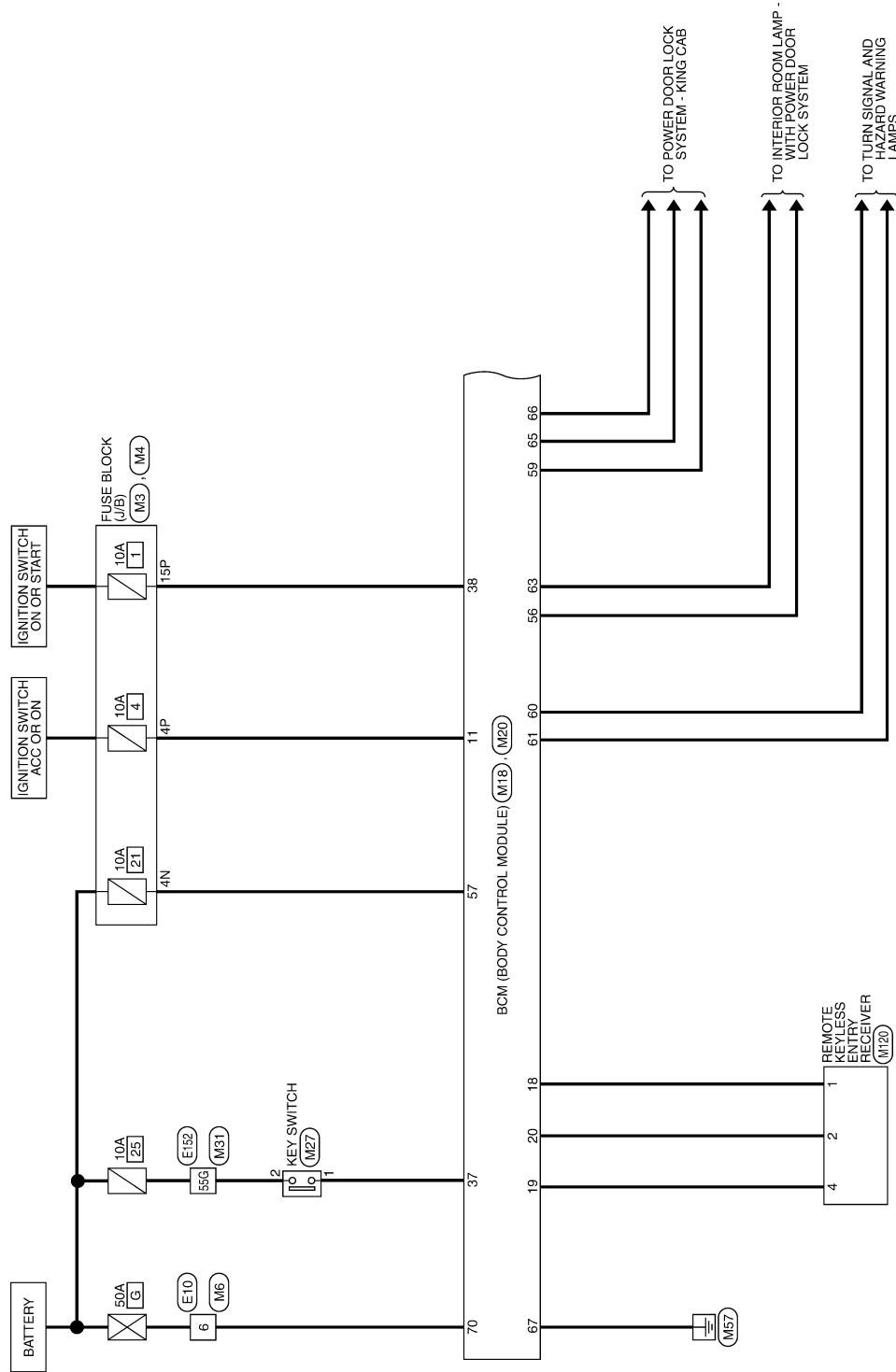

A  
B  
C  
D  
E  
F  
G  
H  
I  
J  
K  
L  
M  
N  
O  
P

DLK

ABKWA1570GB

# REMOTE KEYLESS ENTRY SYSTEM

< WIRING DIAGRAM >

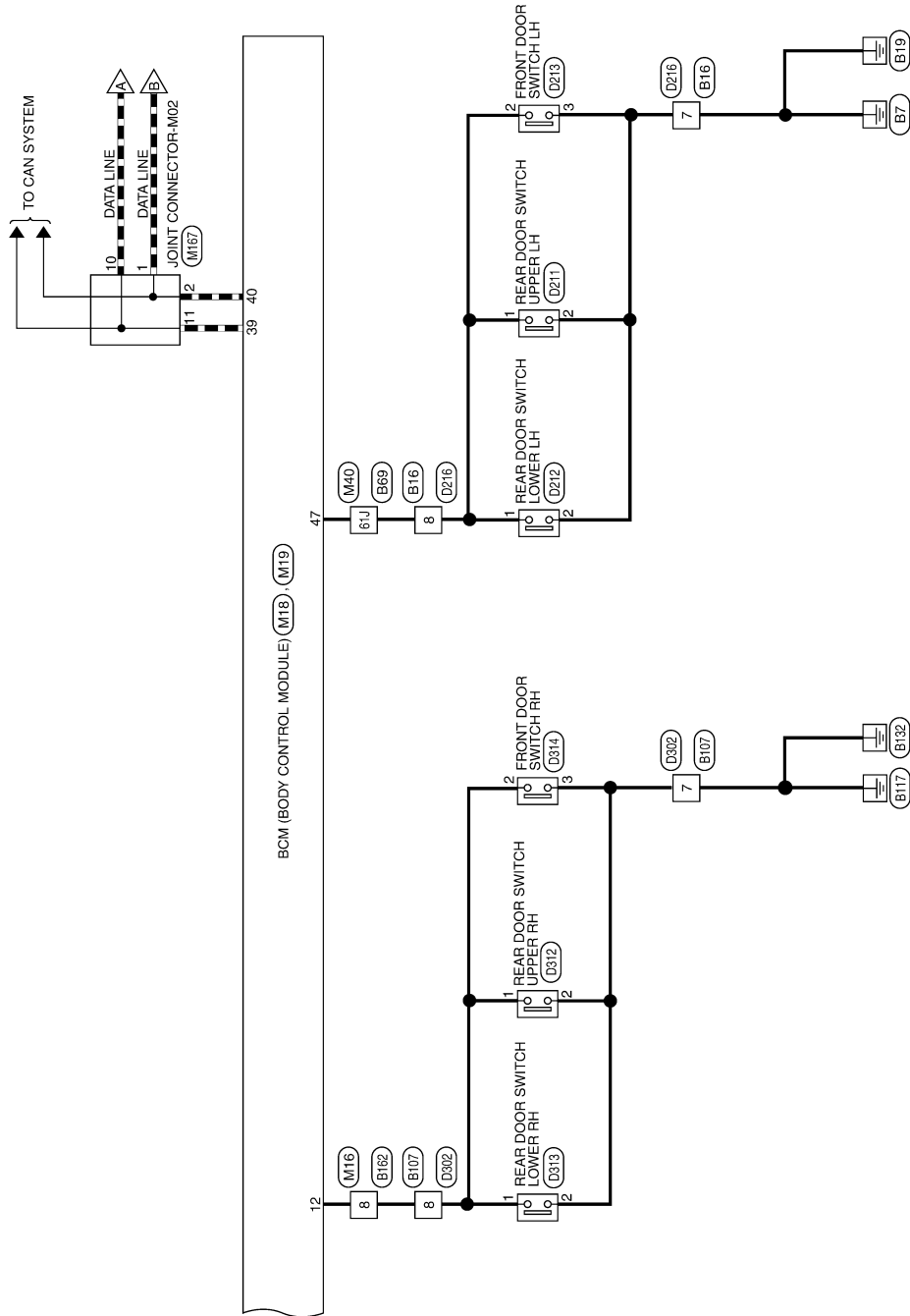

ABKWA1571GB

# REMOTE KEYLESS ENTRY SYSTEM

< WIRING DIAGRAM >

DN : WITH DUAL NOTE HORN  
QR : WITH QR25DE  
ZV : WITH VQ40DE

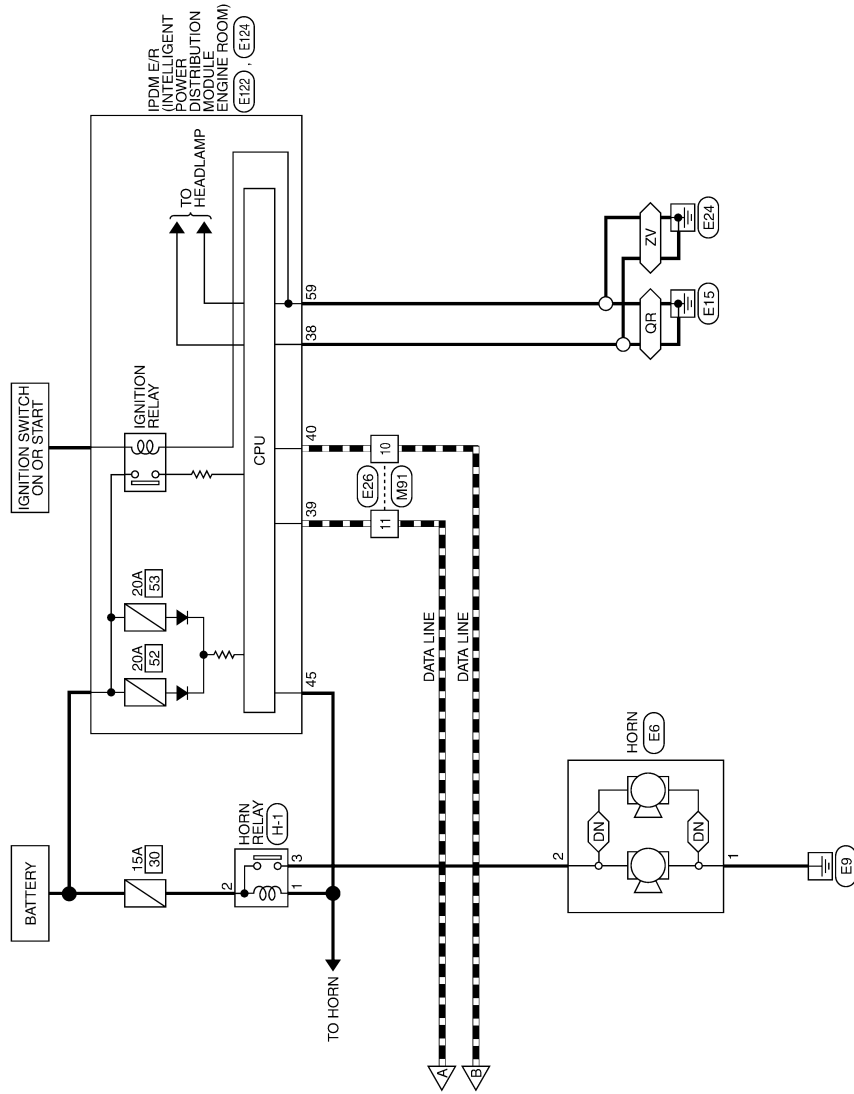

ABKWA1996GB

A  
B  
C  
D  
E  
F  
G  
H  
I  
J  
DLK  
L  
M  
N  
O  
P

# REMOTE KEYLESS ENTRY SYSTEM

< WIRING DIAGRAM >

## REMOTE KEYLESS ENTRY SYSTEM CONNECTORS - KING CAB

Connector No.	M3
Connector Name	FUSE BLOCK (J/B)
Connector Color	WHITE

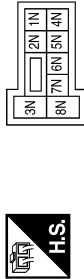

Terminal No.	4N	Color of Wire	R/Y	Signal Name	-
--------------	----	---------------	-----	-------------	---

Connector No.	M4
Connector Name	FUSE BLOCK (J/B)
Connector Color	WHITE



Terminal No.	4P	Color of Wire	G/B	Signal Name	-
Terminal No.	15P	Color of Wire	W/R	Signal Name	-

Connector No.	M6
Connector Name	WIRE TO WIRE
Connector Color	WHITE



Terminal No.	6	Color of Wire	W	Signal Name	-
--------------	---	---------------	---	-------------	---

Connector No.	M16
Connector Name	WIRE TO WIRE
Connector Color	WHITE

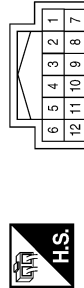

Terminal No.	8	Color of Wire	LG	Signal Name	-
--------------	---	---------------	----	-------------	---

Connector No.	M18
Connector Name	BCM (BODY CONTROL MODULE)
Connector Color	WHITE

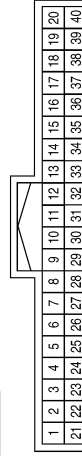

Terminal No.	11	Color of Wire	G/B	Signal Name	ACC SW
Terminal No.	12	Color of Wire	LG	Signal Name	DOOR SW (AS)
Terminal No.	18	Color of Wire	BR	Signal Name	KEYLESS & AUTO LIGHT SENSOR GND
Terminal No.	19	Color of Wire	V	Signal Name	KEYLESS TUNER POWER SUPPLY OUTPUT
Terminal No.	20	Color of Wire	G	Signal Name	KEYLESS TUNER SIGNAL
Terminal No.	37	Color of Wire	B	Signal Name	KEY SW
Terminal No.	38	Color of Wire	W/R	Signal Name	IGN SW
Terminal No.	39	Color of Wire	L	Signal Name	CAN-H
Terminal No.	40	Color of Wire	P	Signal Name	CAN-L

# REMOTE KEYLESS ENTRY SYSTEM

< WIRING DIAGRAM >

Terminal No.	Color of Wire	Signal Name
60	LG	FLASHER OUTPUT (LEFT)
61	G	FLASHER OUTPUT (RIGHT)
63	BR	ROOM LAMP OUTPUT
65	V	DOOR LOCK OUTPUT (ALL)
66	L	DOOR UNLOCK OUTPUT (OTHER)
67	B	GND (POWER)
70	W	BAT (FL)

Connector No.	M20
Connector Name	BCM (BODY CONTROL MODULE)
Connector Color	BLACK

56	57	58	59	60	61	62	63	64
65	66	67	68	69	70			



Terminal No.	Color of Wire	Signal Name
56	R/Y	BATTERY SAVER OUTPUT
57	R/Y	BAT (FUSE)
59	GR	DOOR UNLOCK OUTPUT (DR)

Connector No.	M19
Connector Name	BCM (BODY CONTROL MODULE)
Connector Color	WHITE

41	42	43	44	45	46	47	48	49
50	51	52	53	54	55			



Terminal No.	Color of Wire	Signal Name
47	GR	DOOR SW (DR)

Terminal No.	Color of Wire	Signal Name
55G	Y	-

Connector No.	M31
Connector Name	WIRE TO WIRE
Connector Color	WHITE

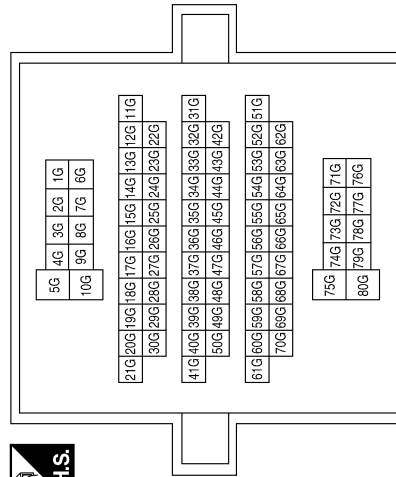

Connector No.	M27
Connector Name	KEY SWITCH
Connector Color	WHITE



Terminal No.	Color of Wire	Signal Name
1	B	-
2	Y	-

ABK1A1843GB

A B C D E F G H I J L M N O P

DLK

# REMOTE KEYLESS ENTRY SYSTEM

< WIRING DIAGRAM >

Connector No.	M120
Connector Name	REMOTE KEYLESS ENTRY RECEIVER
Connector Color	WHITE

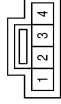

Terminal No.	Color of Wire	Signal Name
1	BR	-
2	G	-
3	-	-
4	V	-

Connector No.	M91
Connector Name	WIRE TO WIRE
Connector Color	WHITE

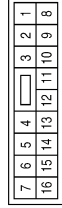

Terminal No.	Color of Wire	Signal Name
10	P	-
11	L	-

Connector No.	M40
Connector Name	WIRE TO WIRE
Connector Color	WHITE

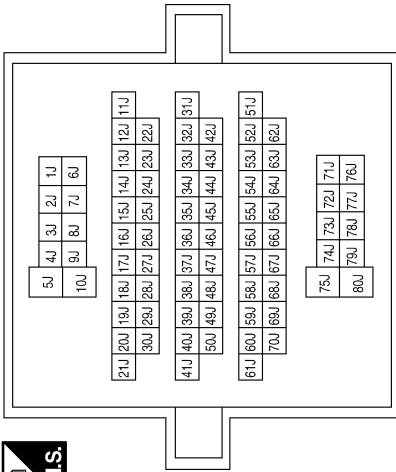

Terminal No.	Color of Wire	Signal Name
61J	GR	-

Connector No.	E10
Connector Name	WIRE TO WIRE
Connector Color	WHITE

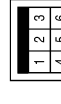

Terminal No.	Color of Wire	Signal Name
6	W	-

Connector No.	E6
Connector Name	HORN
Connector Color	BLACK



Terminal No.	Color of Wire	Signal Name
1	B	-
2	G	-

Connector No.	M167
Connector Name	JOINT CONNECTOR-M02
Connector Color	BLUE

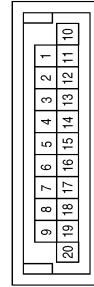

Terminal No.	Color of Wire	Signal Name
1	P	-
2	P	-
10	L	-
11	L	-

ABKIA4352GB

# REMOTE KEYLESS ENTRY SYSTEM

< WIRING DIAGRAM >

Connector No.	E124
Connector Name	IPDM E/R (INTELLIGENT POWER DISTRIBUTION MODULE ENGINE ROOM)
Connector Color	BLACK



Terminal No.	Color of Wire	Signal Name
59	B	GND (POWER)

Connector No.	E122
Connector Name	IPDM E/R (INTELLIGENT POWER DISTRIBUTION MODULE ENGINE ROOM)
Connector Color	WHITE

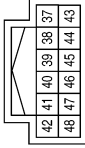

Terminal No.	Color of Wire	Signal Name
38	B	GND (SIGNAL)
39	L	CAN-H
40	P	CAN-L
45	LG	ANT THEFT HORN

Connector No.	E26
Connector Name	WIRE TO WIRE
Connector Color	WHITE

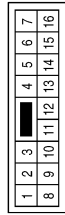

Terminal No.	Color of Wire	Signal Name
10	P	-
11	L	-

Connector No.	B16
Connector Name	WIRE TO WIRE
Connector Color	WHITE



Terminal No.	Color of Wire	Signal Name
7	B	-
8	GR	-

Terminal No.	55G	Color of Wire	Y	Signal Name	-
--------------	-----	---------------	---	-------------	---

Connector No.	E152
Connector Name	WIRE TO WIRE
Connector Color	WHITE

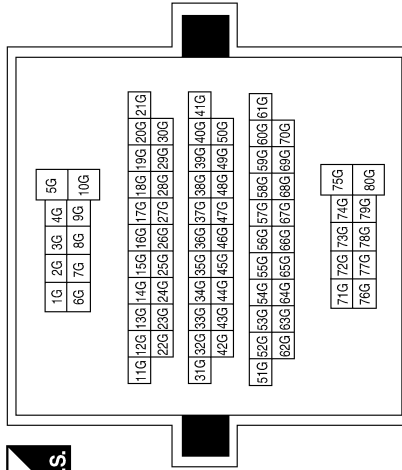

ABKIA3338GB

A  
B  
C  
D  
E  
F  
G  
H  
I  
J  
K  
L  
M  
N  
O  
P

DLK

# REMOTE KEYLESS ENTRY SYSTEM

< WIRING DIAGRAM >

Connector No.	B107
Connector Name	WIRE TO WIRE
Connector Color	WHITE

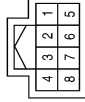

Terminal No.	Color of Wire	Signal Name
7	B	-
8	LG	-

Terminal No.	Color of Wire	Signal Name
61J	GR	-

Connector No.	B69
Connector Name	WIRE TO WIRE
Connector Color	WHITE

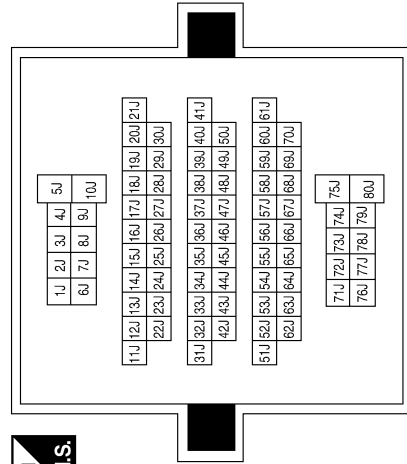

Connector No.	D212
Connector Name	REAR DOOR SWITCH LOWER LH
Connector Color	BLACK



Terminal No.	Color of Wire	Signal Name
1	L	-
2	B	-

Connector No.	D211
Connector Name	REAR DOOR SWITCH UPPER LH
Connector Color	BLACK



Terminal No.	Color of Wire	Signal Name
1	L	-
2	B	-

Connector No.	B162
Connector Name	WIRE TO WIRE
Connector Color	WHITE

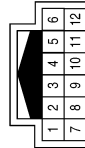

Terminal No.	Color of Wire	Signal Name
8	LG	-

ABKIA4353GB



# REMOTE KEYLESS ENTRY SYSTEM

< WIRING DIAGRAM >

Connector No.	D302
Connector Name	WIRE TO WIRE
Connector Color	WHITE

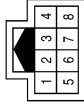

Terminal No.	Color of Wire	Signal Name
7	B	-
8	LG	-

Connector No.	D216
Connector Name	WIRE TO WIRE
Connector Color	WHITE

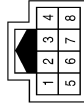

Terminal No.	Color of Wire	Signal Name
7	B	-
8	LG	-

Connector No.	D213
Connector Name	FRONT DOOR SWITCH LH (KING CAB)
Connector Color	WHITE

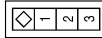

Terminal No.	Color of Wire	Signal Name
2	LG	-
3	B	-

Connector No.	D314
Connector Name	FRONT DOOR SWITCH RH (KING CAB)
Connector Color	WHITE

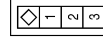

Terminal No.	Color of Wire	Signal Name
2	LG	-
3	B	-

Connector No.	D313
Connector Name	REAR DOOR SWITCH LOWER RH
Connector Color	BLACK



Terminal No.	Color of Wire	Signal Name
1	L	-
2	B	-

Connector No.	D312
Connector Name	REAR DOOR SWITCH UPPER RH
Connector Color	BLACK



Terminal No.	Color of Wire	Signal Name
1	L	-
2	B	-

ABKIA3340GB

A B C D E F G H I J L M N O P

DLK

# REMOTE KEYLESS ENTRY SYSTEM

< WIRING DIAGRAM >

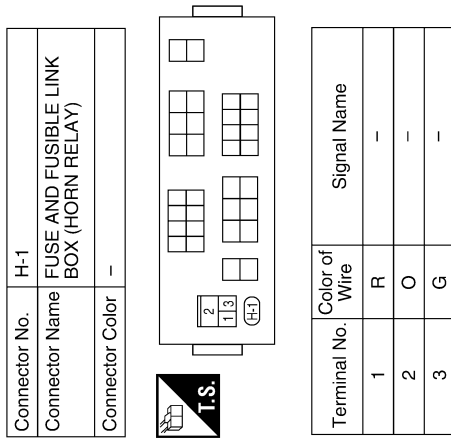

ABKIA4362GB

# REMOTE KEYLESS ENTRY SYSTEM

< WIRING DIAGRAM >

## Wiring Diagram - Crew Cab

INFOID:000000008792326

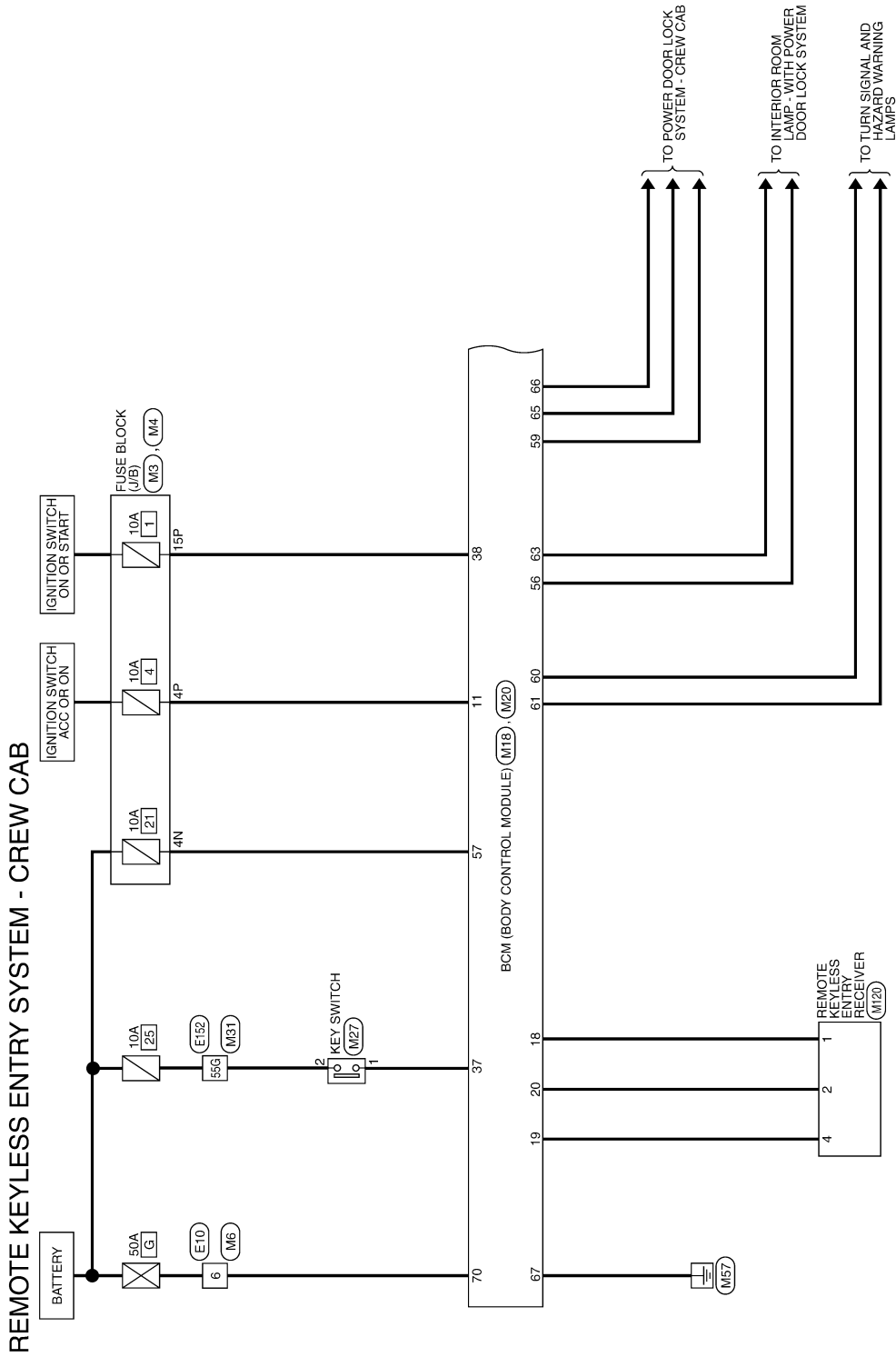

A  
B  
C  
D  
E  
F  
G  
H  
I  
J  
DLK  
L  
M  
N  
O  
P

DLK

ABKWA1572GB

# REMOTE KEYLESS ENTRY SYSTEM

< WIRING DIAGRAM >

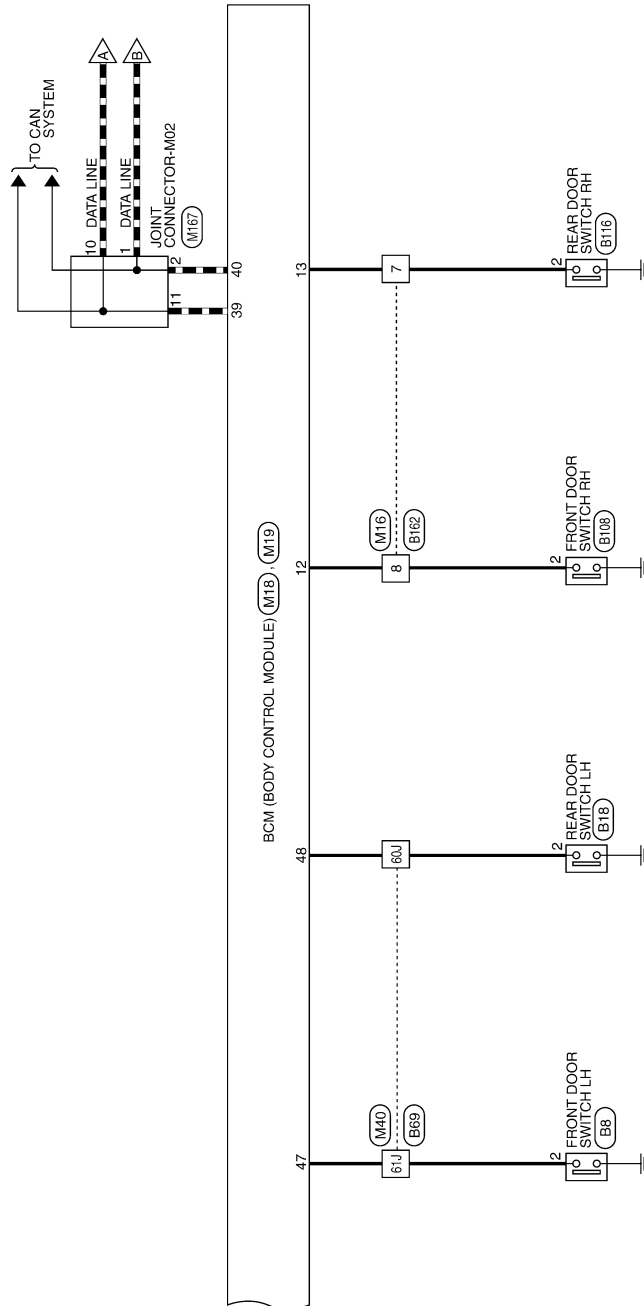

ABKWA1573GB



# REMOTE KEYLESS ENTRY SYSTEM

< WIRING DIAGRAM >

## REMOTE KEYLESS ENTRY SYSTEM CONNECTORS - CREW CAB

Connector No.	M3
Connector Name	FUSE BLOCK (J/B)
Connector Color	WHITE

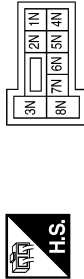

Terminal No.	4N	Color of Wire	R/Y	Signal Name	-
--------------	----	---------------	-----	-------------	---

Connector No.	M4
Connector Name	FUSE BLOCK (J/B)
Connector Color	WHITE



Terminal No.	4P	Color of Wire	G/B	Signal Name	-
Terminal No.	15P	Color of Wire	W/R	Signal Name	-

Connector No.	M6
Connector Name	WIRE TO WIRE
Connector Color	WHITE



Terminal No.	6	Color of Wire	W	Signal Name	-
--------------	---	---------------	---	-------------	---

Connector No.	M16
Connector Name	WIRE TO WIRE
Connector Color	WHITE

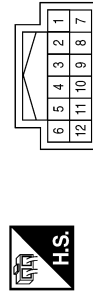

Terminal No.	7	Color of Wire	L	Signal Name	-
Terminal No.	8	Color of Wire	LG	Signal Name	-

Connector No.	M18
Connector Name	BCM (BODY CONTROL MODULE)
Connector Color	WHITE

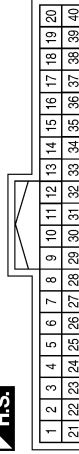

Terminal No.	11	Color of Wire	G/B	Signal Name	ACC SW
Terminal No.	12	Color of Wire	LG	Signal Name	DOOR SW (AS)
Terminal No.	13	Color of Wire	L	Signal Name	DOOR SW (RR)
Terminal No.	18	Color of Wire	BR	Signal Name	KEYLESS & AUTO LIGHT SENSOR GND
Terminal No.	19	Color of Wire	V	Signal Name	KEYLESS TUNER POWER SUPPLY OUTPUT
Terminal No.	20	Color of Wire	G	Signal Name	KEYLESS TUNER SIGNAL
Terminal No.	37	Color of Wire	B	Signal Name	KEY SW
Terminal No.	38	Color of Wire	W/R	Signal Name	IGN SW
Terminal No.	39	Color of Wire	L	Signal Name	CAN-H
Terminal No.	40	Color of Wire	P	Signal Name	CAN-L

# REMOTE KEYLESS ENTRY SYSTEM

< WIRING DIAGRAM >

Terminal No.	Color of Wire	Signal Name
60	LG	FLASHER OUTPUT (LEFT)
61	G	FLASHER OUTPUT (RIGHT)
63	BR	ROOM LAMP OUTPUT
65	V	DOOR LOCK OUTPUT (ALL)
66	L	DOOR UNLOCK OUTPUT (OTHER)
67	B	GND (POWER)
70	W	BAT (F/L)

Connector No.	M20
Connector Name	BCM (BODY CONTROL MODULE)
Connector Color	BLACK



56	57	59	60	61	62	63	64
----	----	----	----	----	----	----	----

Terminal No.	Color of Wire	Signal Name
56	R/Y	BATTERY SAVER OUTPUT
57	R/Y	BAT (FUSE)
59	GR	DOOR UNLOCK OUTPUT (DR)

Connector No.	M19
Connector Name	BCM (BODY CONTROL MODULE)
Connector Color	WHITE



47	48	49	50	51	52	53	54	55
----	----	----	----	----	----	----	----	----

Terminal No.	Color of Wire	Signal Name
47	GR	DOOR SW (DR)
48	P	DOOR SW (RL)

Terminal No.	Color of Wire	Signal Name
55G	Y	-

Connector No.	M31
Connector Name	WIRE TO WIRE
Connector Color	WHITE

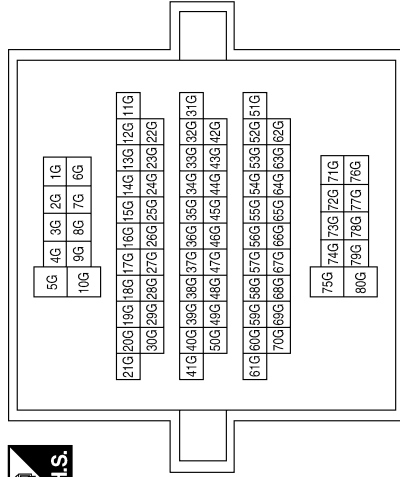

Connector No.	M27
Connector Name	KEY SWITCH
Connector Color	WHITE



2	1
---	---

Terminal No.	Color of Wire	Signal Name
1	B	-
2	Y	-

ABK1A1846GB

A  
B  
C  
D  
E  
F  
G  
H  
I  
J  
K  
L  
M  
N  
O  
P

DLK

# REMOTE KEYLESS ENTRY SYSTEM

< WIRING DIAGRAM >

Connector No.	M91
Connector Name	WIRE TO WIRE
Connector Color	WHITE

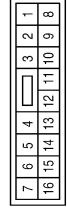

Terminal No.	Color of Wire	Signal Name
10	P	-
11	L	-

Terminal No.	Color of Wire	Signal Name
60J	P	-
61J	GR	-

Connector No.	M40
Connector Name	WIRE TO WIRE
Connector Color	WHITE

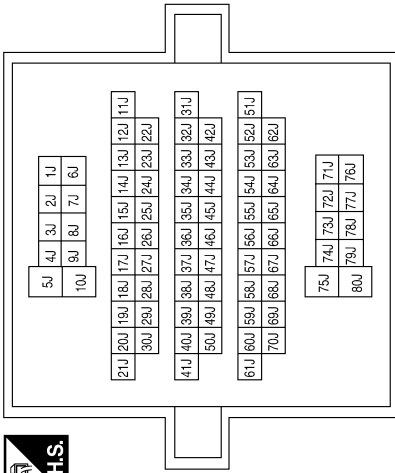

Connector No.	E6
Connector Name	HORN
Connector Color	BLACK



Terminal No.	Color of Wire	Signal Name
1	B	-
2	G	-

Connector No.	M167
Connector Name	JOINT CONNECTOR-M02
Connector Color	BLUE

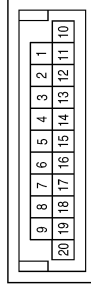

Terminal No.	Color of Wire	Signal Name
1	P	-
2	P	-
10	L	-
11	L	-

Connector No.	M120
Connector Name	REMOTE KEYLESS ENTRY RECEIVER
Connector Color	WHITE

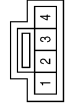

Terminal No.	Color of Wire	Signal Name
1	BR	-
2	G	-
3	-	-
4	V	-

ABKIA4351GB



# REMOTE KEYLESS ENTRY SYSTEM

< WIRING DIAGRAM >

Connector No.	E10
Connector Name	WIRE TO WIRE
Connector Color	WHITE



Terminal No.	Color of Wire	Signal Name
6	W	-

Connector No.	E26
Connector Name	WIRE TO WIRE
Connector Color	WHITE

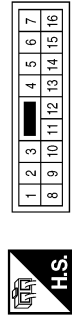

Terminal No.	Color of Wire	Signal Name
10	P	-
11	L	-

Connector No.	E122
Connector Name	IPDM E/R (INTELLIGENT POWER DISTRIBUTION MODULE ENGINE ROOM)
Connector Color	WHITE

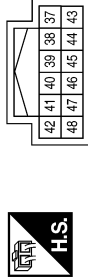

Terminal No.	Color of Wire	Signal Name
38	B	GND (SIGNAL)
39	L	CAN-H
40	P	CAN-L
45	LG	ANT THEFT HORN

Connector No.	E124
Connector Name	IPDM E/R (INTELLIGENT POWER DISTRIBUTION MODULE ENGINE ROOM)
Connector Color	BLACK



Terminal No.	Color of Wire	Signal Name
59	B	GND (POWER)

Connector No.	E152
Connector Name	WIRE TO WIRE
Connector Color	WHITE

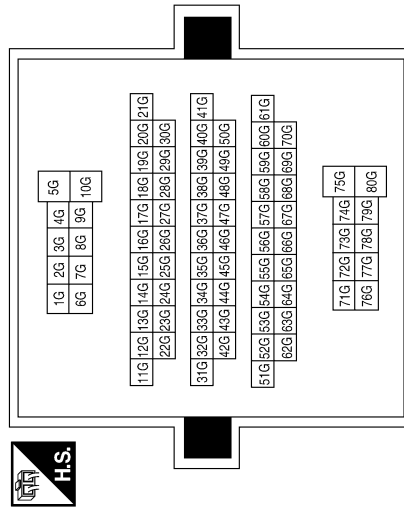

Terminal No.	Color of Wire	Signal Name
55G	Y	-

Connector No.	B8
Connector Name	FRONT DOOR SWITCH LH (CREW CAB)
Connector Color	WHITE



Terminal No.	Color of Wire	Signal Name
2	GR	-

ABKIA3343GB

A B C D E F G H I J L M N O P

DLK

# REMOTE KEYLESS ENTRY SYSTEM

< WIRING DIAGRAM >

Connector No.	B108
Connector Name	FRONT DOOR SWITCH RH (CREW CAB)
Connector Color	WHITE

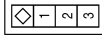

Terminal No.	2	Color of Wire	LG	Signal Name	-
--------------	---	---------------	----	-------------	---

Connector No.	B69
Connector Name	WIRE TO WIRE
Connector Color	WHITE

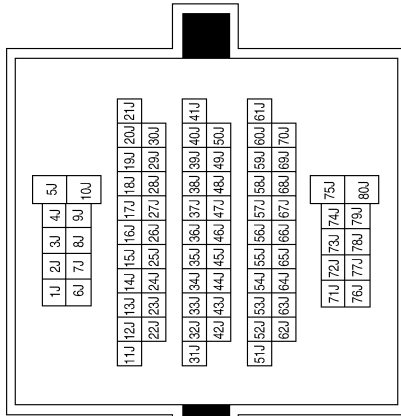

Terminal No.	60J	Color of Wire	P	Signal Name	-
	61J	Color of Wire	GR	Signal Name	-

Connector No.	B18
Connector Name	REAR DOOR SWITCH LH
Connector Color	WHITE

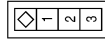

Terminal No.	2	Color of Wire	P	Signal Name	-
--------------	---	---------------	---	-------------	---

Connector No.	B162
Connector Name	WIRE TO WIRE
Connector Color	WHITE

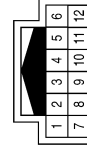

Terminal No.	7	Color of Wire	L	Signal Name	-
	8	Color of Wire	LG	Signal Name	-

Connector No.	B116
Connector Name	REAR DOOR SWITCH RH
Connector Color	WHITE

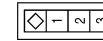

Terminal No.	2	Color of Wire	L	Signal Name	-
--------------	---	---------------	---	-------------	---

ABKIA3344GB

# REMOTE KEYLESS ENTRY SYSTEM

< WIRING DIAGRAM >

A  
B  
C  
D  
E  
F  
G  
H  
I  
J  
DLK  
L  
M  
N  
O  
P

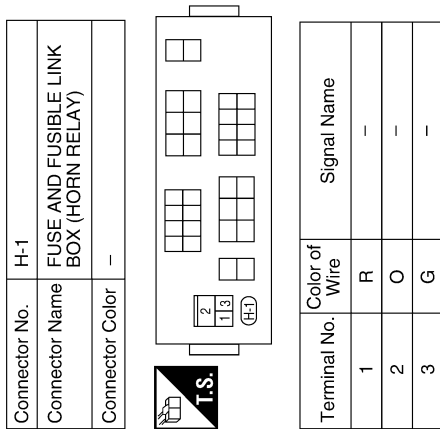

ABKIA4361GB

# DOOR LOCK

< SYMPTOM DIAGNOSIS >

## SYMPTOM DIAGNOSIS

### DOOR LOCK

#### Symptom Table

INFOID:000000008792327

#### DOOR LOCK SYSTEM

##### NOTE:

- Before performing the diagnosis in the following table, check “Work flow”. Refer to [DLK-4, "Work Flow"](#).
- If the following symptoms are detected, check systems shown in the “Diagnosis/service procedure” column in this order.

Symptom	Repair order	Refer to page
Key reminder door function does not operate properly.	1a. Door switch check (king cab)	<a href="#">DLK-27</a>
	1b. Door switch check (crew cab)	<a href="#">DLK-29</a>
	2. Key switch (Insert) check	<a href="#">DLK-42</a>
	3. Replace BCM.	<a href="#">BCS-49</a>
Power door lock does not operate with door lock and unlock switch on main power window and door lock/unlock switch or power window and door lock/unlock switch RH.	1a. Door lock/unlock switch check (driver side) (king cab)	<a href="#">DLK-32</a>
	1b. Door lock/unlock switch check (driver side) (crew cab)	<a href="#">DLK-32</a>
	2a. Door lock/unlock switch check (passenger side) (king cab)	<a href="#">DLK-32</a>
	2b. Door lock/unlock switch check (passenger side) (crew cab)	<a href="#">DLK-35</a>
Specific door lock actuator does not operate.	1. Door lock actuator check (driver side)	<a href="#">DLK-43</a>
	2. Door lock actuator check (passenger side)	<a href="#">DLK-44</a>
	3. Door lock actuator check (Rear LH) (crew cab)	<a href="#">DLK-45</a>
	4. Door lock actuator check (Rear RH) (crew cab)	<a href="#">DLK-47</a>
Power door lock does not operate with front door key cylinder LH.	1. Front door lock assembly LH (key cylinder switch) check	<a href="#">DLK-39</a>
	2. Replace BCM.	<a href="#">BCS-49</a>
Power door lock does not operate.	1. BCM power supply and ground circuit check	<a href="#">BCS-27</a>
	2a. Door lock/unlock switch check (driver) (king cab)	<a href="#">DLK-32</a>
	2b. Door lock/unlock switch check (driver) (crew cab)	<a href="#">DLK-35</a>
	3a. Door lock/unlock switch check (passenger) (king cab)	<a href="#">DLK-32</a>
	3b. Door lock/unlock switch check (passenger) (crew cab)	<a href="#">DLK-35</a>
Vehicle speed sensing auto LOCK operation does not operate.	1. Ensure automatic door lock/unlock function (lock operation) is enabled.	<a href="#">BCS-15</a>
	2. Check combination meter vehicle speed signal.	<a href="#">MWI-29</a>
	3. Check intermittent incident.	<a href="#">GI-49</a>
Ignition OFF interlock door UNLOCK function does not operate.	1. Ensure automatic door lock/unlock function (unlock operation) is enabled.	<a href="#">BCS-15</a>
	2. Check BCM for DTCs.	<a href="#">BCS-40</a>
	3. Check intermittent incident.	<a href="#">GI-49</a>

# REMOTE KEYLESS ENTRY SYSTEM

< SYMPTOM DIAGNOSIS >

## REMOTE KEYLESS ENTRY SYSTEM

### Symptom Table

INFOID:000000008792328

### REMOTE KEYLESS ENTRY SYSTEM

Symptom	Diagnoses/service procedure	Reference page
All functions of remote keyless entry system do not operate.	1. Keyfob battery and function check (use Remote Keyless Entry Tester J-43241 or Signal Tech II Tool J-50190) <b>NOTE:</b> If the result of keyfob function check is OK, keyfob is not malfunctioning.	<a href="#">DLK-51</a>
	2. Check BCM and remote keyless entry receiver.	<a href="#">DLK-49</a>
The new ID of keyfob cannot be entered.	1. Keyfob battery and function check (use Remote Keyless Entry Tester J-43241 or Signal Tech II Tool J-50190) <b>NOTE:</b> If the result of keyfob function check is OK, keyfob is not malfunctioning.	<a href="#">DLK-51</a>
	2. Key switch (insert) check	<a href="#">DLK-42</a>
	3a. Door switch check (king cab)	<a href="#">DLK-27</a>
	3b. Door switch check (crew cab)	<a href="#">DLK-29</a>
	4. ACC power check	<a href="#">BCS-27</a>
Door lock or unlock does not function. (If the power door lock system does not operate manually, check power door lock system)	1. Keyfob battery and function check (use Remote Keyless Entry Tester J-43241 or Signal Tech II Tool J-50190) <b>NOTE:</b> If the result of keyfob function check is OK, keyfob is not malfunctioning.	<a href="#">DLK-15</a>
	2. Replace BCM.	<a href="#">BCS-49</a>
Hazard and horn reminder does not activate properly when pressing lock or unlock button of keyfob.	1. Check hazard and horn reminder mode with CONSULT <b>NOTE:</b> Hazard and horn reminder mode can be changed. First check the hazard and horn reminder mode setting.	<a href="#">DLK-15</a>
	2a. Door switch check (king cab)	<a href="#">DLK-27</a>
	2b. Door switch check (crew cab)	<a href="#">DLK-29</a>
	3. Replace BCM.	<a href="#">BCS-49</a>
Hazard reminder does not activate properly when pressing lock or unlock button of keyfob. (Horn reminder OK)	1. Check hazard reminder mode with CONSULT <b>NOTE:</b> Hazard reminder mode can be changed. First check the hazard reminder mode setting.	<a href="#">DLK-15</a>
	2. Check hazard function with hazard switch	—
	3. Replace BCM.	<a href="#">BCS-49</a>
Horn reminder does not activate properly when pressing lock or unlock button of keyfob. (Hazard reminder OK)	1. Check horn reminder mode with CONSULT <b>NOTE:</b> Horn reminder mode can be changed. First check the horn reminder mode setting.	<a href="#">DLK-15</a>
	2. Check horn function with horn switch	—
	3. IPDM E/R operation check	<a href="#">DLK-53</a>
	4. Replace BCM.	<a href="#">BCS-49</a>

A

B

C

D

E

F

G

H

I

J

DLK

L

M

N

O

P

# REMOTE KEYLESS ENTRY SYSTEM

## < SYMPTOM DIAGNOSIS >

Symptom	Diagnoses/service procedure	Reference page
Room lamp and ignition keyhole illumination do not operate properly.	1. Room lamp operation check	<a href="#">DLK-58</a>
	2. Ignition keyhole illumination operation check	<a href="#">DLK-58</a>
	3a. Door switch check (king cab)	<a href="#">DLK-27</a>
	3b. Door switch check (crew cab)	<a href="#">DLK-29</a>
	4. Replace BCM.	<a href="#">BCS-49</a>
Panic alarm (horn and headlamp) does not activate when panic alarm button is continuously pressed.	1. Keyfob battery and function check (use Remote Keyless Entry Tester J-43241 or Signal Tech II Tool J-50190) <b>NOTE:</b> If the result of keyfob function check is OK, keyfob is not malfunctioning.	<a href="#">DLK-51</a>
	2. Key switch (insert) check	<a href="#">DLK-42</a>
	3. Replace BCM.	<a href="#">BCS-49</a>
Automatic door lock operation does not activate properly. (All other remote keyless entry functions OK.)	1. Check automatic door lock operation mode with CONSULT <b>NOTE:</b> Automatic door lock operation mode can be changed. First check the automatic door lock operation mode setting.	<a href="#">DLK-12</a>
	2. Replace BCM.	<a href="#">BCS-49</a>

# SQUEAK AND RATTLE TROUBLE DIAGNOSES

< SYMPTOM DIAGNOSIS >

## SQUEAK AND RATTLE TROUBLE DIAGNOSES

### Work Flow

INFOID:000000008792329

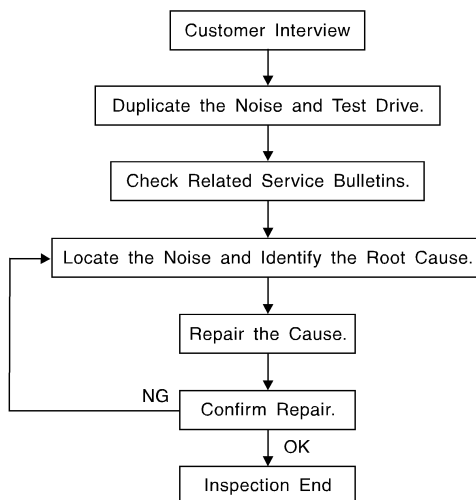

SBT842

### CUSTOMER INTERVIEW

Interview the customer if possible, to determine the conditions that exist when the noise occurs. Use the Diagnostic Worksheet during the interview to document the facts and conditions when the noise occurs and any customer's comments; refer to [DLK-123, "Diagnostic Worksheet"](#). This information is necessary to duplicate the conditions that exist when the noise occurs.

- The customer may not be able to provide a detailed description or the location of the noise. Attempt to obtain all the facts and conditions that exist when the noise occurs (or does not occur).
- If there is more than one noise in the vehicle, be sure to diagnose and repair the noise that the customer is concerned about. This can be accomplished by test driving the vehicle with the customer.
- After identifying the type of noise, isolate the noise in terms of its characteristics. The noise characteristics are provided so the customer, service adviser and technician are all speaking the same language when defining the noise.
- Squeak —(Like tennis shoes on a clean floor)  
Squeak characteristics include the light contact/fast movement/brought on by road conditions/hard surfaces = higher pitch noise/softer surfaces = lower pitch noises/edge to surface = chirping.
- Creak—(Like walking on an old wooden floor)  
Creak characteristics include firm contact/slow movement/twisting with a rotational movement/pitch dependent on materials/often brought on by activity.
- Rattle—(Like shaking a baby rattle)  
Rattle characteristics include the fast repeated contact/vibration or similar movement/loose parts/missing clip or fastener/incorrect clearance.
- Knock —(Like a knock on a door)  
Knock characteristics include hollow sounding/sometimes repeating/often brought on by driver action.
- Tick—(Like a clock second hand)  
Tick characteristics include gentle contacting of light materials/loose components/can be caused by driver action or road conditions.
- Thump—(Heavy, muffled knock noise)  
Thump characteristics include softer knock/dead sound often brought on by activity.
- Buzz—(Like a bumble bee)  
Buzz characteristics include high frequency rattle/firm contact.
- Often the degree of acceptable noise level will vary depending upon the person. A noise that you may judge as acceptable may be very irritating to the customer.
- Weather conditions, especially humidity and temperature, may have a great effect on noise level.

### DUPLICATE THE NOISE AND TEST DRIVE

If possible, drive the vehicle with the customer until the noise is duplicated. Note any additional information on the Diagnostic Worksheet regarding the conditions or location of the noise. This information can be used to duplicate the same conditions when you confirm the repair.

# SQUEAK AND RATTLE TROUBLE DIAGNOSES

## < SYMPTOM DIAGNOSIS >

If the noise can be duplicated easily during the test drive, to help identify the source of the noise, try to duplicate the noise with the vehicle stopped by doing one or all of the following:

- 1) Close a door.
  - 2) Tap or push/pull around the area where the noise appears to be coming from.
  - 3) Rev the engine.
  - 4) Use a floor jack to recreate vehicle "twist".
  - 5) At idle, apply engine load (electrical load, half-clutch on M/T model, drive position on CVT and A/T models).
  - 6) Raise the vehicle on a hoist and hit a tire with a rubber hammer.
- Drive the vehicle and attempt to duplicate the conditions the customer states exist when the noise occurs.
  - If it is difficult to duplicate the noise, drive the vehicle slowly on an undulating or rough road to stress the vehicle body.

## CHECK RELATED SERVICE BULLETINS

After verifying the customer concern or symptom, check ASIST for Technical Service Bulletins (TSBs) related to that concern or symptom.

If a TSB relates to the symptom, follow the procedure to repair the noise.

## LOCATE THE NOISE AND IDENTIFY THE ROOT CAUSE

1. Narrow down the noise to a general area. To help pinpoint the source of the noise, use a listening tool (Chassis Ear: J-39570, Engine Ear: J-39565 and mechanic's stethoscope).
2. Narrow down the noise to a more specific area and identify the cause of the noise by:
  - removing the components in the area that you suspect the noise is coming from.  
Do not use too much force when removing clips and fasteners, otherwise clips and fasteners can be broken or lost during the repair, resulting in the creation of new noise.
  - tapping or pushing/pulling the component that you suspect is causing the noise.  
Do not tap or push/pull the component with excessive force, otherwise the noise will be eliminated only temporarily.
  - feeling for a vibration with your hand by touching the component(s) that you suspect is (are) causing the noise.
  - placing a piece of paper between components that you suspect are causing the noise.
  - looking for loose components and contact marks.Refer to [DLK-121. "Generic Squeak and Rattle Troubleshooting"](#).

## REPAIR THE CAUSE

- If the cause is a loose component, tighten the component securely.
- If the cause is insufficient clearance between components:
  - separate components by repositioning or loosening and retightening the component, if possible.
  - insulate components with a suitable insulator such as urethane pads, foam blocks, felt cloth tape or urethane tape. A NISSAN Squeak and Rattle Kit (J-43980) is available through your authorized NISSAN Parts Department.

### **CAUTION:**

**Do not use excessive force as many components are constructed of plastic and may be damaged.**

**Always check with the Parts Department for the latest parts information.**

**The following materials are contained in the NISSAN Squeak and Rattle Kit (J-43980). Each item can be ordered separately as needed.**

#### **URETHANE PADS [1.5 mm (0.059 in) thick]**

**Insulates connectors, harness, etc.**

**76268-9E005: 100×135 mm (3.94×5.31 in)/76884-71L01: 60×85 mm (2.36×3.35 in)/76884-71L02: 15×25 mm (0.59×0.98 in)**

#### **INSULATOR (Foam blocks)**

**Insulates components from contact. Can be used to fill space behind a panel.**

**73982-9E000: 45 mm (1.77 in) thick, 50×50 mm (1.97×1.97 in)/73982-50Y00: 10 mm (0.39 in) thick, 50×50 mm (1.97×1.97 in)**

#### **INSULATOR (Light foam block)**

**80845-71L00: 30 mm (1.18 in) thick, 30×50 mm (1.18×1.97 in)**

#### **FELT CLOTH TAPE**

**Used to insulate where movement does not occur. Ideal for instrument panel applications.**

**68370-4B000: 15×25 mm (0.59×0.98 in) pad/68239-13E00: 5 mm (0.20 in) wide tape roll. The following materials not found in the kit can also be used to repair squeaks and rattles.**

#### **UHMW (TEFLON) TAPE**

**Insulates where slight movement is present. Ideal for instrument panel applications.**

#### **SILICONE GREASE**



# SQUEAK AND RATTLE TROUBLE DIAGNOSES

## < SYMPTOM DIAGNOSIS >

Used instead of UHMW tape that will be visible or not fit.

Note: Will only last a few months.

### SILICONE SPRAY

Use when grease cannot be applied.

### DUCT TAPE

Use to eliminate movement.

### CONFIRM THE REPAIR

Confirm that the cause of a noise is repaired by test driving the vehicle. Operate the vehicle under the same conditions as when the noise originally occurred. Refer to the notes on the Diagnostic Worksheet.

## Generic Squeak and Rattle Troubleshooting

INFOID:000000009227623

Refer to Table of Contents for specific component removal and installation information.

### INSTRUMENT PANEL

Most incidents are caused by contact and movement between:

1. Cluster lid A and the instrument panel
2. Acrylic lens and combination meter housing
3. Instrument panel to front pillar finisher
4. Instrument panel to windshield
5. Instrument panel pins
6. Wiring harnesses behind the combination meter
7. A/C defroster duct and duct joint

These incidents can usually be located by tapping or moving the components to duplicate the noise or by pressing on the components while driving to stop the noise. Most of these incidents can be repaired by applying felt cloth tape or silicone spray (in hard to reach areas). Urethane pads can be used to insulate wiring harness.

### CAUTION:

Do not use silicone spray to isolate a squeak or rattle. If you saturate the area with silicone, you will not be able to recheck the repair.

### CENTER CONSOLE

Components to pay attention to include:

1. Shift selector assembly cover to finisher
2. A/C control unit and cluster lid C
3. Wiring harnesses behind audio and A/C control unit

The instrument panel repair and isolation procedures also apply to the center console.

### DOORS

Pay attention to the:

1. Finisher and inner panel making a slapping noise
2. Inside handle escutcheon to door finisher
3. Wiring harnesses tapping
4. Door striker out of alignment causing a popping noise on starts and stops

Tapping or moving the components or pressing on them while driving to duplicate the conditions can isolate many of these incidents. You can usually insulate the areas with felt cloth tape or insulator foam blocks from the NISSAN Squeak and Rattle Kit (J-43980) to repair the noise.

### TRUNK

Trunk noises are often caused by a loose jack or loose items put into the trunk by the owner.

In addition look for:

1. Trunk lid bumpers out of adjustment
2. Trunk lid striker out of adjustment
3. The trunk lid torsion bars knocking together
4. A loose license plate or bracket

A

B

C

D

E

F

G

H

I

J

DLK

L

M

N

O

P

# SQUEAK AND RATTLE TROUBLE DIAGNOSES

## < SYMPTOM DIAGNOSIS >

---

Most of these incidents can be repaired by adjusting, securing or insulating the item(s) or component(s) causing the noise.

### SUNROOF/HEADLINING

Noises in the sunroof/headlining area can often be traced to one of the following:

1. Sunroof lid, rail, linkage or seals making a rattle or light knocking noise
2. Sun visor shaft shaking in the holder
3. Front or rear windshield touching headlining and squeaking

Again, pressing on the components to stop the noise while duplicating the conditions can isolate most of these incidents. Repairs usually consist of insulating with felt cloth tape.

### OVERHEAD CONSOLE (FRONT AND REAR)

Overhead console noises are often caused by the console panel clips not being engaged correctly. Most of these incidents are repaired by pushing up on the console at the clip locations until the clips engage.

In addition look for:

1. Loose harness or harness connectors.
2. Front console map/reading lamp lens loose.
3. Loose screws at console attachment points.

### SEATS

When isolating seat noise it's important to note the position the seat is in and the load placed on the seat when the noise is present. These conditions should be duplicated when verifying and isolating the cause of the noise.

Cause of seat noise include:

1. Headrest rods and holder
2. A squeak between the seat pad cushion and frame
3. The rear seatback lock and bracket

These noises can be isolated by moving or pressing on the suspected components while duplicating the conditions under which the noise occurs. Most of these incidents can be repaired by repositioning the component or applying urethane tape to the contact area.

### UNDERHOOD

Some interior noise may be caused by components under the hood or on the engine wall. The noise is then transmitted into the passenger compartment.

Causes of transmitted underhood noise include:

1. Any component installed to the engine wall
2. Components that pass through the engine wall
3. Engine wall mounts and connectors
4. Loose radiator installation pins
5. Hood bumpers out of adjustment
6. Hood striker out of adjustment

These noises can be difficult to isolate since they cannot be reached from the interior of the vehicle. The best method is to secure, move or insulate one component at a time and test drive the vehicle. Also, engine rpm or load can be changed to isolate the noise. Repairs can usually be made by moving, adjusting, securing, or insulating the component causing the noise.

# SQUEAK AND RATTLE TROUBLE DIAGNOSES

< SYMPTOM DIAGNOSIS >

## Diagnostic Worksheet

INFOID:000000008792331

Dear Customer:

We are concerned about your satisfaction with your vehicle. Repairing a squeak or rattle sometimes can be very difficult. To help us fix your vehicle right the first time, please take a moment to note the area of the vehicle where the squeak or rattle occurs and under what conditions. You may be asked to take a test drive with a service advisor or technician to ensure we confirm the noise you are hearing.

### SQUEAK & RATTLE DIAGNOSTIC WORKSHEET

#### I. WHERE DOES THE NOISE COME FROM? (circle the area of the vehicle)

The illustrations are for reference only, and may not reflect the actual configuration of your vehicle.

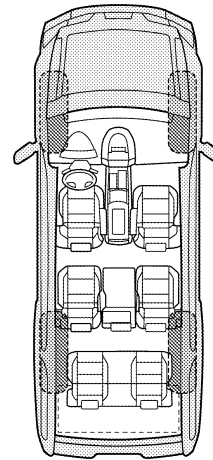
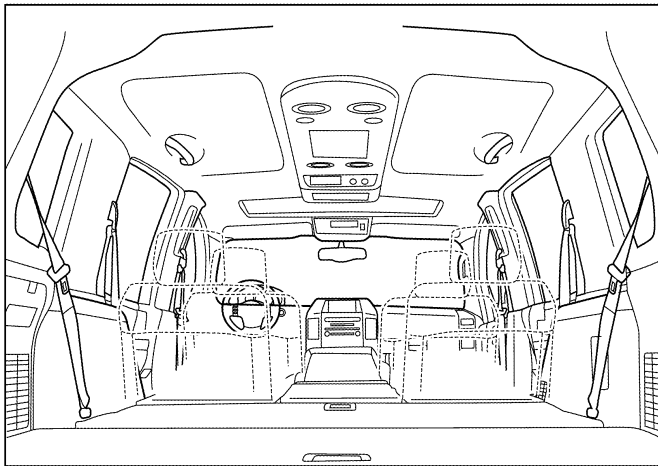
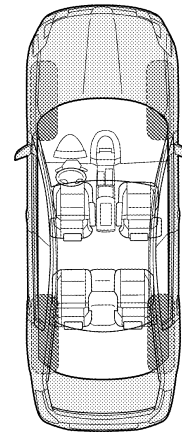
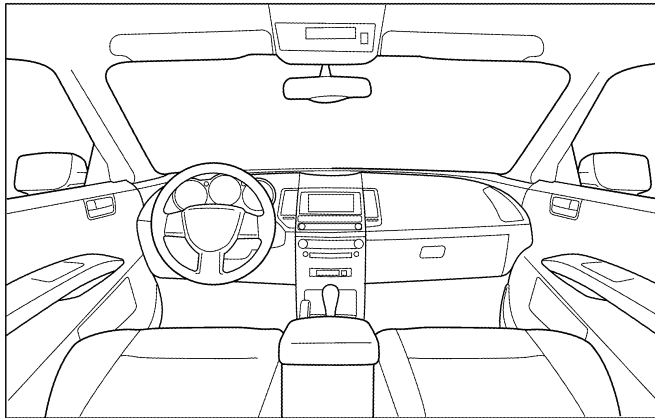

Continue to page 2 of the worksheet and briefly describe the location of the noise or rattle. In addition, please indicate the conditions which are present when the noise occurs.

A  
B  
C  
D  
E  
F  
G  
H  
I  
J  
DLK  
L  
M  
N  
O  
P

# SQUEAK AND RATTLE TROUBLE DIAGNOSES

< SYMPTOM DIAGNOSIS >

## SQUEAK & RATTLE DIAGNOSTIC WORKSHEET - page 2

Briefly describe the location where the noise occurs:

---



---

### II. WHEN DOES IT OCCUR? (please check the boxes that apply)

- |   |  |
|---|--|
| <input type="checkbox"/> Anytime                      | <input type="checkbox"/> After sitting out in the rain |
| <input type="checkbox"/> 1st time in the morning      | <input type="checkbox"/> When it is raining or wet     |
| <input type="checkbox"/> Only when it is cold outside | <input type="checkbox"/> Dry or dusty conditions       |
| <input type="checkbox"/> Only when it is hot outside  | <input type="checkbox"/> Other:                        |

### III. WHEN DRIVING:

- Through driveways
- Over rough roads
- Over speed bumps
- Only about \_\_\_\_ mph
- On acceleration
- Coming to a stop
- On turns: left, right or either (circle)
- With passengers or cargo
- Other: \_\_\_\_\_
- After driving \_\_\_\_ miles or \_\_\_\_ minutes

### IV. WHAT TYPE OF NOISE

- Squeak (like tennis shoes on a clean floor)
- Creak (like walking on an old wooden floor)
- Rattle (like shaking a baby rattle)
- Knock (like a knock at the door)
- Tick (like a clock second hand)
- Thump (heavy muffled knock noise)
- Buzz (like a bumble bee)

### TO BE COMPLETED BY DEALERSHIP PERSONNEL

Test Drive Notes:

---



---



---

	YES	NO	Initials of person performing
Vehicle test driven with customer	<input type="checkbox"/>	<input type="checkbox"/>	_____
- Noise verified on test drive	<input type="checkbox"/>	<input type="checkbox"/>	_____
- Noise source located and repaired	<input type="checkbox"/>	<input type="checkbox"/>	_____
- Follow up test drive performed to confirm repair	<input type="checkbox"/>	<input type="checkbox"/>	_____

VIN: \_\_\_\_\_ Customer Name \_\_\_\_\_  
 W.O.# \_\_\_\_\_ Date: \_\_\_\_\_

This form must be attached to Work Order

LATA0071E

# PRECAUTIONS

< PRECAUTION >

## PRECAUTION

### PRECAUTIONS

#### Precaution for Supplemental Restraint System (SRS) "AIR BAG" and "SEAT BELT PRE-TENSIONER"

INFOID:000000008792332

The Supplemental Restraint System such as "AIR BAG" and "SEAT BELT PRE-TENSIONER", used along with a front seat belt, helps to reduce the risk or severity of injury to the driver and front passenger for certain types of collision. This system includes seat belt switch inputs and dual stage front air bag modules. The SRS system uses the seat belt switches to determine the front air bag deployment, and may only deploy one front air bag, depending on the severity of a collision and whether the front occupants are belted or unbelted. Information necessary to service the system safely is included in the SR and SB section of this Service Manual.

#### **WARNING:**

- To avoid rendering the SRS inoperative, which could increase the risk of personal injury or death in the event of a collision which would result in air bag inflation, all maintenance must be performed by an authorized NISSAN/INFINITI dealer.
- Improper maintenance, including incorrect removal and installation of the SRS, can lead to personal injury caused by unintentional activation of the system. For removal of Spiral Cable and Air Bag Module, see the SR section.
- Do not use electrical test equipment on any circuit related to the SRS unless instructed to in this Service Manual. SRS wiring harnesses can be identified by yellow and/or orange harnesses or harness connectors.

#### PRECAUTIONS WHEN USING POWER TOOLS (AIR OR ELECTRIC) AND HAMMERS

#### **WARNING:**

- When working near the Airbag Diagnosis Sensor Unit or other Airbag System sensors with the Ignition ON or engine running, DO NOT use air or electric power tools or strike near the sensor(s) with a hammer. Heavy vibration could activate the sensor(s) and deploy the air bag(s), possibly causing serious injury.
- When using air or electric power tools or hammers, always switch the Ignition OFF, disconnect the battery, and wait at least 3 minutes before performing any service.

#### Precaution for Work Door and Lock

INFOID:000000009227624

#### **WARNING:**

Radio waves could adversely affect electric medical equipment. Those who use a pacemaker should contact the electric medical equipment manufacturer for the possible influences before use.

- When removing or disassembling each component, be careful not to damage or deform it. If a component may be subject to interference, be sure to protect it with a shop cloth.
- When removing (disengaging) components with a screwdriver or similar tool, be sure to wrap the component with a shop cloth or vinyl tape to protect it.
- Protect the removed parts with a shop cloth and prevent them from being dropped.
- Replace a deformed or damaged clip.
- If a part is specified as a non-reusable part, always replace it with a new one.
- Be sure to tighten bolts and nuts securely to the specified torque.
- After installation is complete, be sure to check that each part works properly.
- Follow the steps below to clean components:
  - Water soluble dirt:
    - Dip a soft cloth into lukewarm water, wring the water out of the cloth and wipe the dirty area.
    - Then rub with a soft, dry cloth.
  - Oily dirt:
    - Dip a soft cloth into lukewarm water with mild detergent (concentration: within 2 to 3%) and wipe the dirty area.
    - Then dip a cloth into fresh water, wring the water out of the cloth and wipe the detergent off.
    - Then rub with a soft, dry cloth.
  - Do not use organic solvent such as thinner, benzene, alcohol or gasoline.
  - For genuine leather seats, use a genuine leather seat cleaner.

A  
B  
C  
D  
E  
F  
G  
H  
I  
J  
L  
M  
N  
O  
P

DLK

# PREPARATION



< PREPARATION >

## PREPARATION

### PREPARATION

#### Special Service Tool

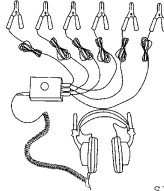
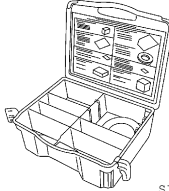
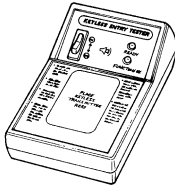
INFOID:000000008792334

Tool number (Kent-Moore No.) Tool name	Description
<p>— (J-39570) Chassis ear</p>  <p style="text-align: right;">S1IA0993E</p>	<p>Locating the noise</p>
<p>— (J-43980) NISSAN Squeak and Rattle Kit</p>  <p style="text-align: right;">S1IA0994E</p>	<p>Repairing the cause of noise</p>
<p>— (J-43241) Remote Keyless Entry Tester</p>  <p style="text-align: right;">LEL946A</p>	<p>Used to test key fobs</p>
<p>— (J-50190) Signal Tech II</p>  <p style="text-align: right;">ALEIA0131ZZ</p>	<ul style="list-style-type: none"> <li>• Activate and display TPMS transmitter IDs</li> <li>• Display tire pressure reported by the TPMS transmitter</li> <li>• Read TPMS DTCs</li> <li>• Register TPMS transmitter IDs</li> <li>• Test remote keyless entry keyfob relative signal strength</li> </ul>

#### Commercial Service Tool

INFOID:000000008792335

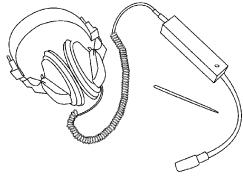
Tool number (Kent-Moore No.) Tool name	Description
<p>(J-39565) Engine ear</p>  <p style="text-align: right;">S1IA0995E</p>	<p>Locating the noise</p>

# HOOD

< REMOVAL AND INSTALLATION >

## REMOVAL AND INSTALLATION

### HOOD

#### Fitting Adjustment

INFOID:000000008792336

SEC.650

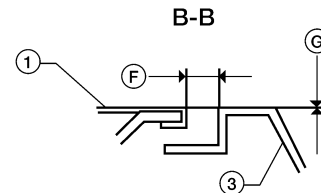
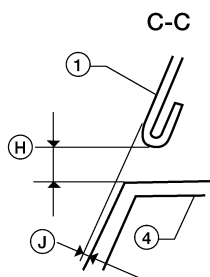
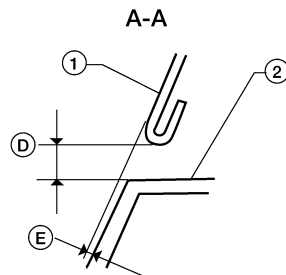
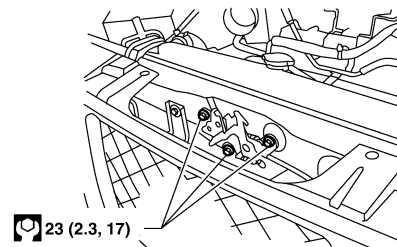
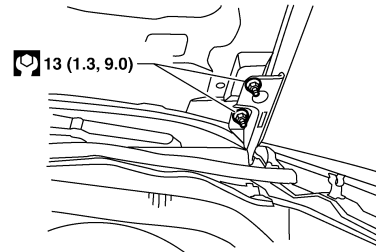
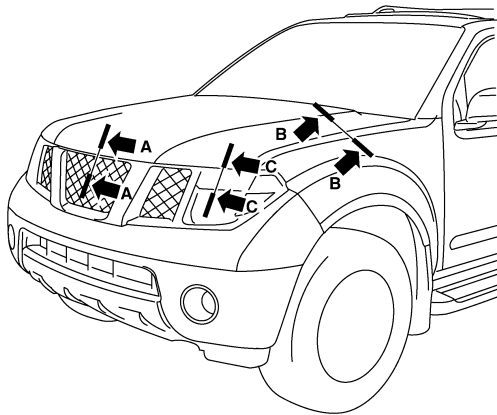

- |                      |                     |                     |
|----------------------|---------------------|---------------------|
| 1. Hood              | 2. Front grille     | 3. Front fender     |
| 4. Headlamp assembly | D. 6.0 mm (0.24 in) | E. 0.7 mm (0.03 in) |
| F. 4.6 mm (0.18 in)  | G. 0.0 mm (0.0 in)  | H. 6.0 mm (0.24 in) |
| J. 0.7 mm (0.03 in)  |                     |                     |

#### CLEARANCE AND SURFACE HEIGHT ADJUSTMENT

1. Remove the front grille. Refer to [EXT-23, "Removal and Installation"](#).
2. Loosen the hood lock assembly and adjust the rubber bumpers until the surface height of the hood becomes 1 mm (0.04 in) lower than the fender.
3. Engage the hood striker and temporarily tighten.
4. Check the lock and striker for looseness.

A  
B  
C  
D  
E  
F  
G  
H  
I  
J  
DLK  
L  
M  
N  
O  
P

# HOOD

## < REMOVAL AND INSTALLATION >

5. Tighten the bolts to specification.
6. Adjust the surface height of the hood according to the fitting standard dimension by rotating right and left rubber bumpers.
7. Install the front grille. Refer to [EXT-23, "Removal and Installation"](#).

## HOOD LOCK ADJUSTMENT

1. Remove the front grille. Refer to [EXT-23, "Removal and Installation"](#).
2. Move the hood lock to the left or right so that striker (1) center is vertically aligned with primary latch (4) center (when viewed from vehicle front).

**A** : More than 5.0 mm (0.197 in)

**B** : 20 mm (0.79 in)

3. Make sure the secondary latch (3) is properly engaged with the secondary striker (2) with hood's own weight by dropping it from approximately 200 mm (7.87 in) height or by pressing it lightly approximately 3 kg (29 N, 7 lb).

### CAUTION:

**Do not drop the hood from 300 mm (11.81 in) height or higher.**

4. After adjusting hood lock, tighten the lock bolts to the specified torque.

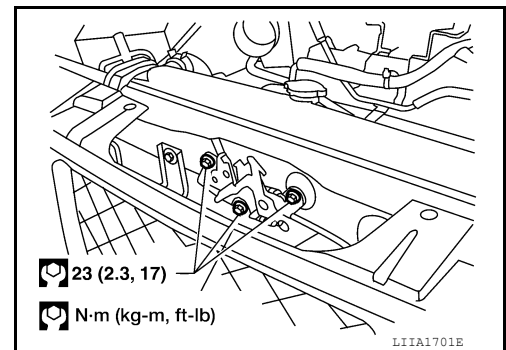
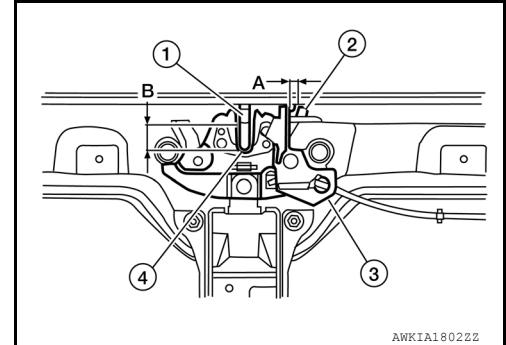

5. Install the front grille. Refer to [EXT-23, "Removal and Installation"](#).

## Removal and Installation of Hood Assembly

INFOID:000000008792337

## REMOVAL

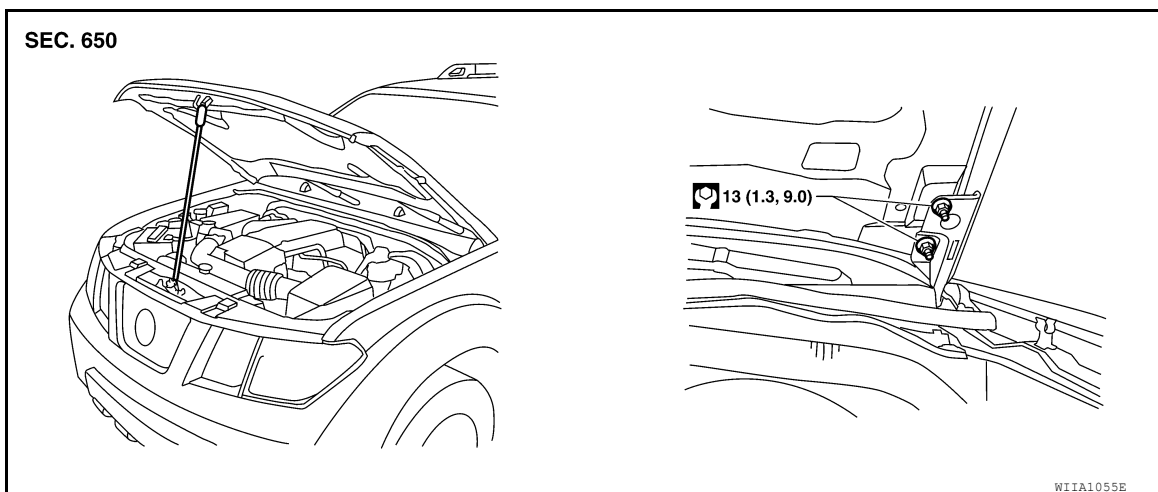

1. Support the hood striker with suitable tool to prevent it from falling.
2. Remove the hinge nuts from the hood to remove the hood assembly.

### CAUTION:

**Operate with two workers, because of its heavy weight.**

## INSTALLATION



# HOOD

## < REMOVAL AND INSTALLATION >

Installation is in the reverse order of removal.

### Removal and Installation of Hood Lock Control

INFOID:000000008792338

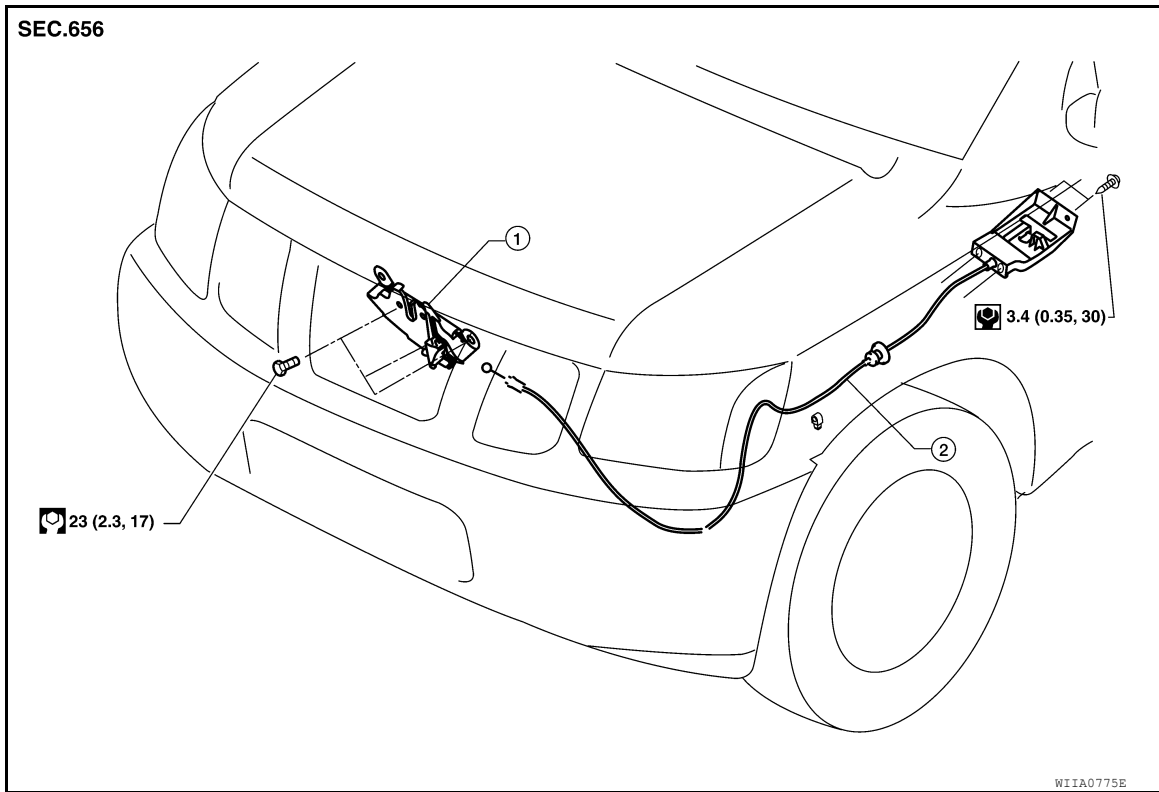

1. Hood lock assembly

2. Hood lock cable

#### REMOVAL

1. Disconnect the hood lock cable from the hood lock, and unclip it from the radiator core support upper and hoodledge.
2. Remove the bolts, and the hood release handle.
3. Separate the grommet from the lower dash panel. Pull the hood lock cable out through the passenger compartment.

#### **CAUTION:**

**While pulling, be careful not to damage the outside of the hood lock cable.**

#### INSTALLATION

1. Pull the hood lock cable through the lower dash panel hole into the engine room.

#### **CAUTION:**

A  
B  
C  
D  
E  
F  
G  
H  
I  
J  
L  
M  
N  
O  
P

DLK

# HOOD

## < REMOVAL AND INSTALLATION >

**Be careful not to bend the cable too much, keep the radius 100mm (3.94 in) or more.**

2. Make sure the cable is not offset from the grommet, and push the grommet into the lower dash panel hole securely.
3. Apply sealant around the grommet at \* mark.

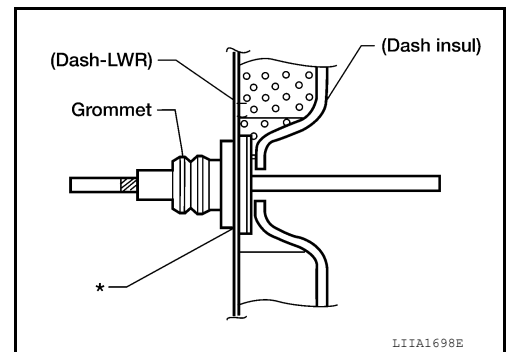

4. Install the cable securely to the lock.
5. Adjust the hood lock. Refer to [DLK-127, "Fitting Adjustment"](#).

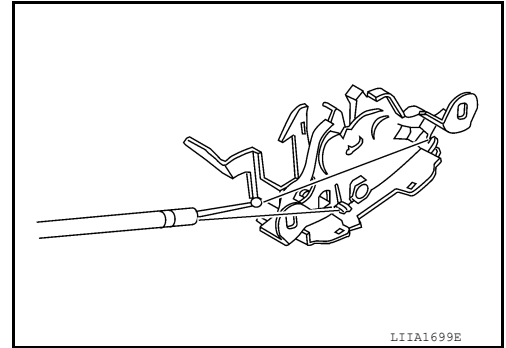

## Hood Lock Control Inspection

INFOID:000000008792339

1. Make sure the hood lock cable is not bent or deformed. If the cable is damaged, replace it.
2. Remove the front grille. Refer to [EXT-23](#).
3. Make sure the secondary latch is properly engaged with the secondary striker with hood's own weight by dropping it from approx. 200 mm (7.87 in) height.
4. While operating the hood opener, carefully make sure the front end of the hood is raised by approx. 20 mm (0.79 in). Also make sure the hood opener returns to the original position.

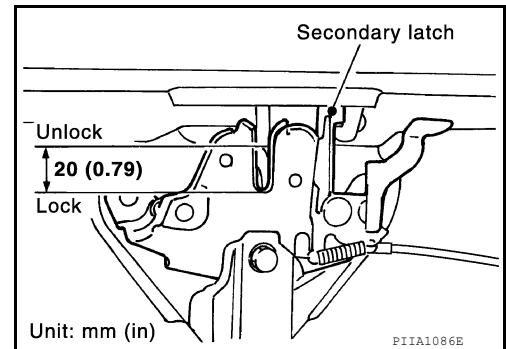

5. Check the hood lock lubrication condition. If necessary, apply "body grease" to the points shown.

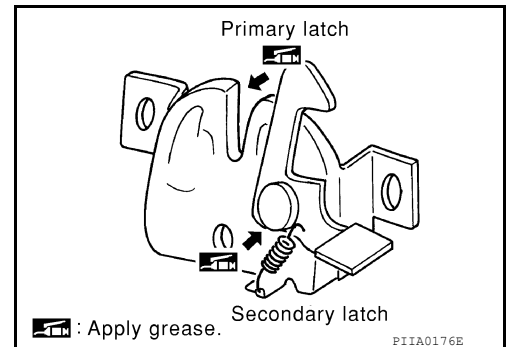

6. Install the front grille. Refer to [EXT-23](#).

# DOOR

< REMOVAL AND INSTALLATION >

## DOOR

### Fitting Adjustment

INFOID:000000008792340

#### KING CAB

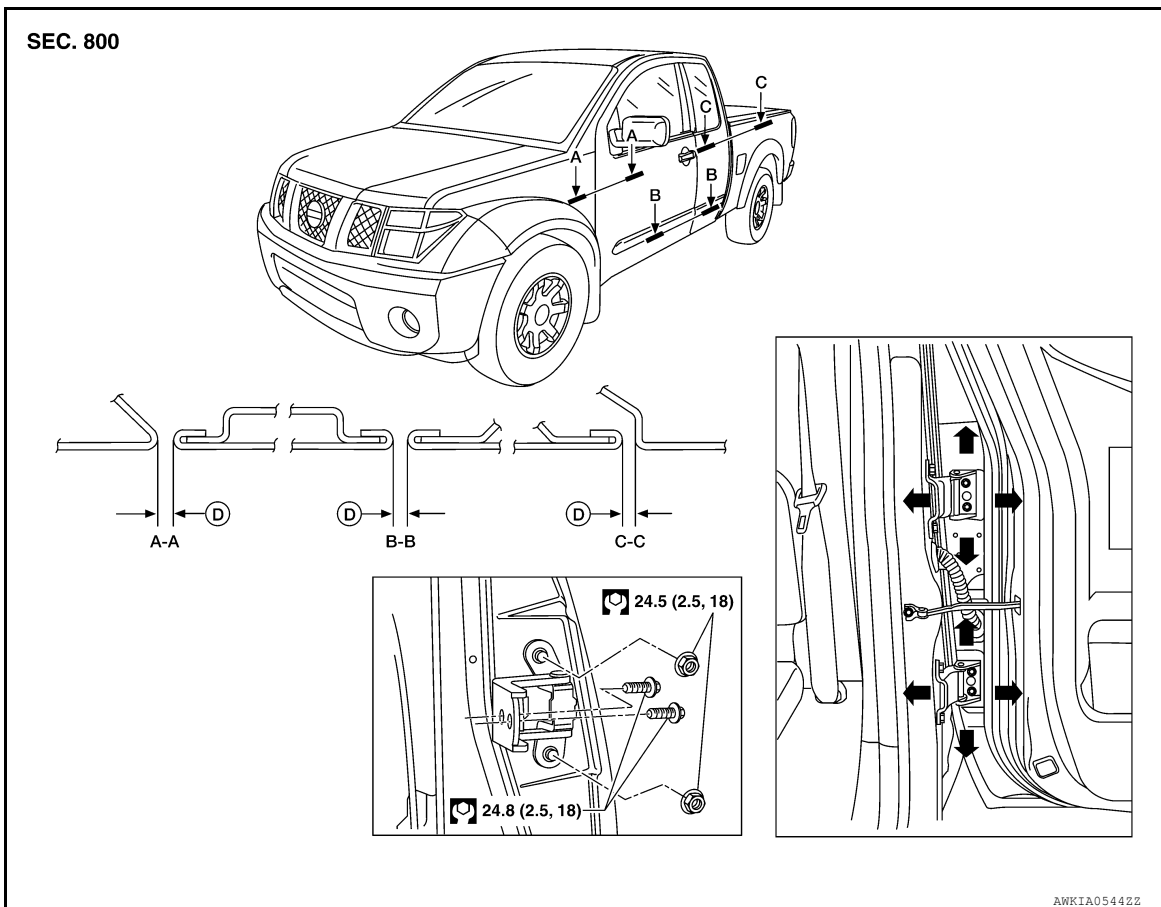

D. 4.5 mm ± 1.0 mm (0.177 in ± 0.039 in)

A  
B  
C  
D  
E  
F  
G  
H  
I  
J

DLK

L  
M  
N  
O  
P

# DOOR

## < REMOVAL AND INSTALLATION >

### CREW CAB

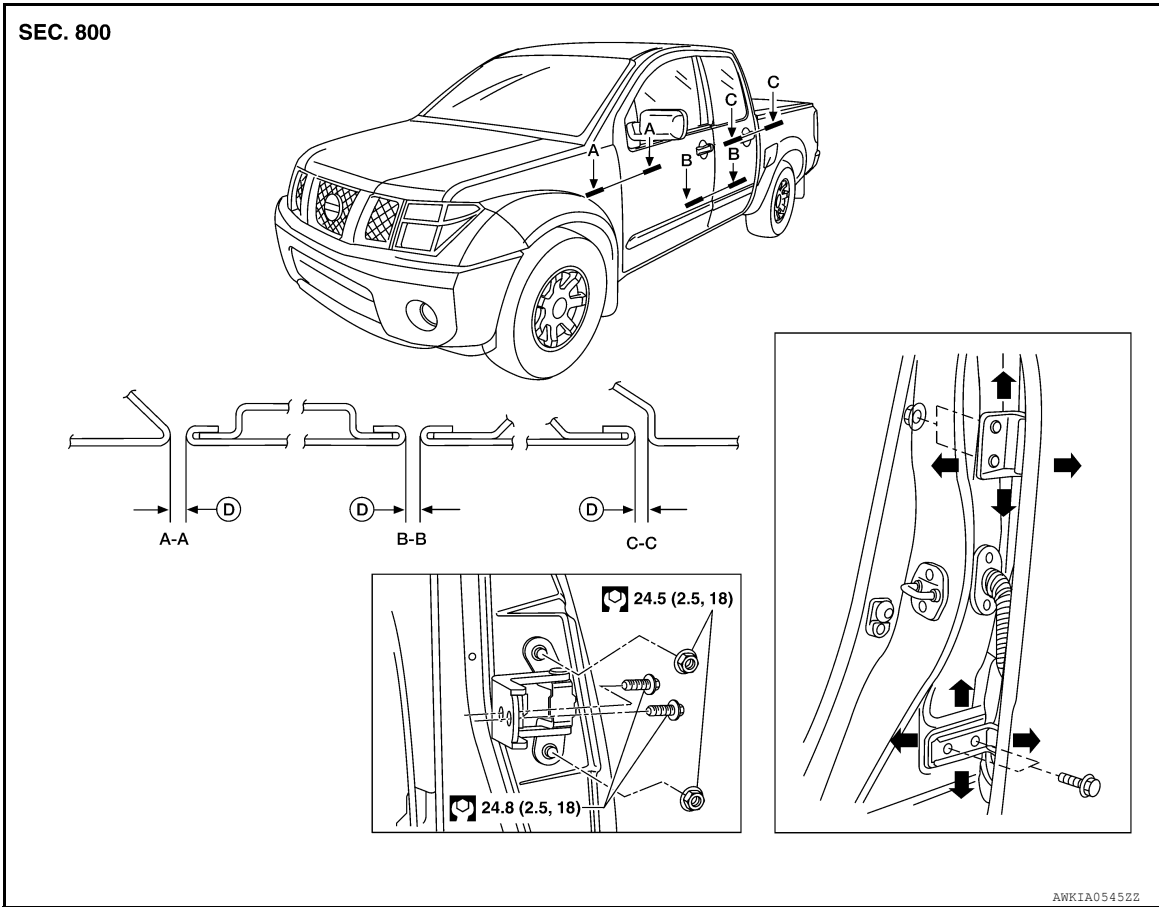

D. 4.5 mm ± 1.0 mm (0.177 in ± 0.039 in)

### FRONT DOOR

Longitudinal clearance and surface height adjustment at front end

1. Remove the front fender. Refer to [EXT-25. "Removal and Installation"](#).
2. Loosen the hinge bolts. Raise the front door at rear end to adjust.
3. Install the front fender. Refer to [EXT-25. "Removal and Installation"](#).

### REAR DOOR

Longitudinal clearance and surface height adjustment at front end

1. Remove the center pillar upper finisher. Refer to [INT-18. "Component"](#).
2. Accessing from inside the vehicle, loosen the nuts. Open the rear door, and raise the rear door at rear end to adjust.
3. Install the center pillar lower finisher. Refer to [INT-18. "Component"](#).

### STRIKER ADJUSTMENT

1. Adjust the striker so that it becomes parallel with the lock insertion direction.

**Striker bolts : 16.7 N·m (1.7 kg-m, 12 ft-lb)**

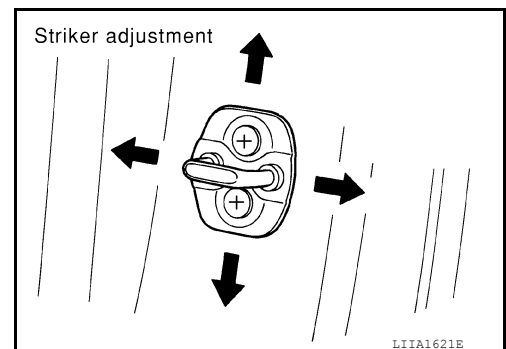

# DOOR

## < REMOVAL AND INSTALLATION >

- Remove the upper striker covers and adjust the striker so that it becomes parallel with the lock insertion direction.

**Striker bolts : 16.7 N·m (1.7 kg-m, 12 ft-lb)**

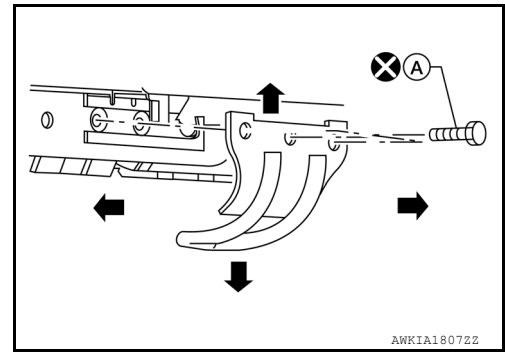

## Removal and Installation

INFOID:000000008792341

### KING CAB

#### Front Door

#### REMOVAL

##### CAUTION:

- When removing and installing the door assembly, support the door with a jack and shop cloth to protect the door and body.
- When removing and installing door assembly, be sure to carry out the fitting adjustment.
- Check the hinge rotating part for poor lubrication. If necessary, apply body grease.

- Remove the front door glass and regulator assembly. Refer to [GW-16. "Front Door Glass Regulator"](#).
- Remove the door harness.
- Remove the check link cover.
- Remove the check link bolt from the hinge pillar.

**Check link bolt to hinge pillar : 14.7 N·m (1.5 kg-m, 11 ft-lb)**

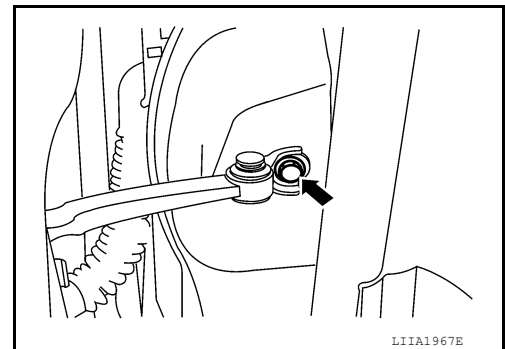

- Remove the door-side hinge nuts and bolts, and remove the door assembly.

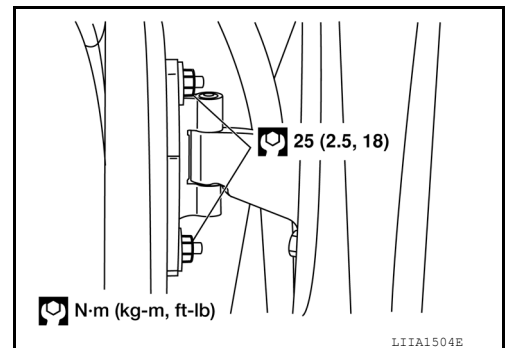

#### INSTALLATION

Installation is in the reverse order of removal.

#### Rear Door

#### REMOVAL

##### CAUTION:

A  
B  
C  
D  
E  
F  
G  
H  
I  
J  
DLK  
L  
M  
N  
O  
P

# DOOR

## < REMOVAL AND INSTALLATION >

- When removing and installing the door assembly, support the door with a jack and shop cloth to protect the door and body.
  - When removing and installing door assembly, be sure to carry out the fitting adjustment.
  - Check the hinge rotating part for poor lubrication. If necessary, apply body grease.
1. Remove the door glass. Refer to [GW-20, "Rear Door Glass"](#).
  2. Remove the speaker.
  3. Remove the door handles and latch assembly. Refer to [DLK-139, "Component Structure"](#).
  4. Remove the check link.
  5. Remove the harness.
  6. Remove the door assembly.

**Door hinge nuts** : 24.5 N·m (2.5 kg-m, 18 ft-lb)

**Check link bolt to door** : 5.1 N·m (0.52 kg-m, 45 in-lb)

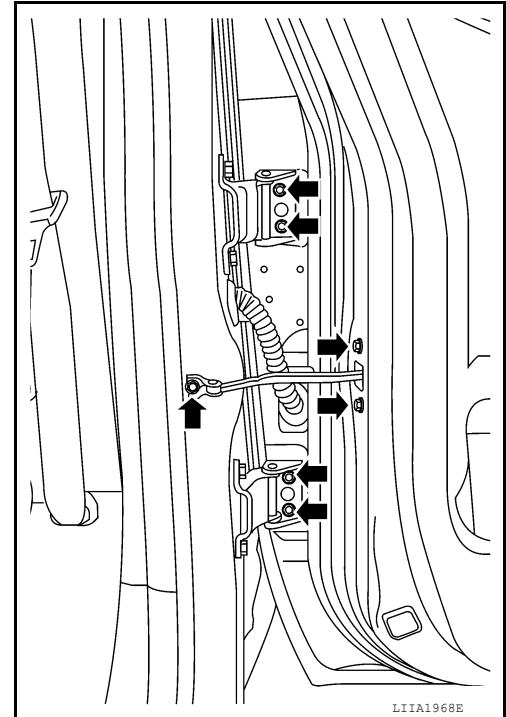

## INSTALLATION

Installation is in the reverse order of removal.

## CREW CAB

## REMOVAL

### CAUTION:

- When removing and installing the door assembly, support the door with a jack and shop cloth to protect the door and body.
  - When removing and installing door assembly, be sure to carry out the fitting adjustment.
  - Check the hinge rotating part for poor lubrication. If necessary, apply body grease.
1. Remove the door finisher. Refer to [INT-15, "Removal and Installation"](#).
  2. Remove the inner seal.
  3. Remove the door glass and regulator assembly. Refer to [GW-16, "Front Door Glass"](#).
  4. Remove the door harness.
  5. Remove the check link cover.

# DOOR

## < REMOVAL AND INSTALLATION >

6. Remove the check link bolt from the hinge pillar.

**Front door check link bolt to hinge pillar : 14.7 N·m (1.5 kg-m, 11 ft - lb)**  
**Rear door check link bolt to hinge pillar : 14.7 N·m (1.5 kg-m, 11 ft - lb)**

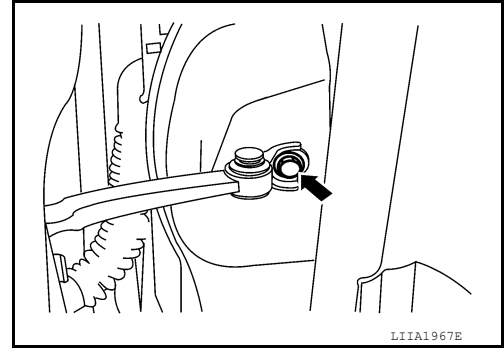

7. Remove the door-side hinge nuts and bolts, and remove the door assembly.

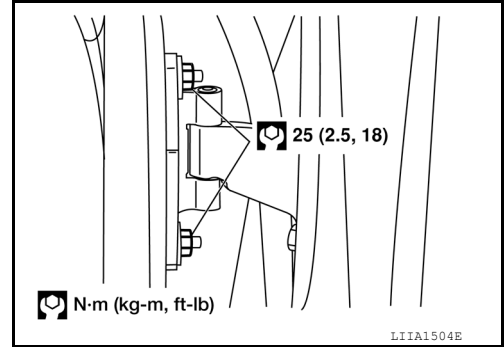

## INSTALLATION

Installation is in the reverse order of removal.

A  
B  
C  
D  
E  
F  
G  
H  
I  
J  
L  
M  
N  
O  
P

DLK

# FRONT DOOR LOCK

< REMOVAL AND INSTALLATION >

## FRONT DOOR LOCK

### Component Structure

INFOID:000000008792342

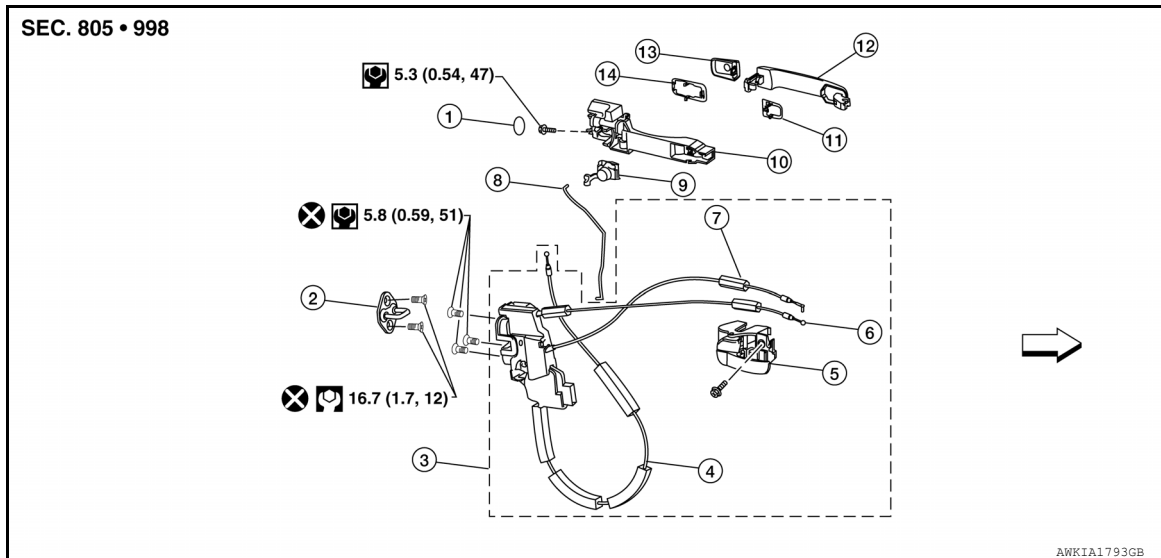

- |  |  |                        |
|--|--|------------------------|
| 1. Grommet                                   | 2. Front door striker                  | 3. Door lock assembly  |
| 4. Outside handle cable                      | 5. Inside handle assembly              | 6. Inside handle cable |
| 7. Door lock cable                           | 8. Key cylinder rod (Driver side only) | 9. Door key cylinder   |
| 10. Outside handle bracket                   | 11. Front gasket                       | 12. Outside handle     |
| 13. Door key cylinder assembly (Driver side) | 14. Rear gasket                        | ← Vehicle front        |
| Outside handle escutcheon (Passenger side)   |  |                        |

### Removal and Installation

INFOID:000000008792343

#### REMOVAL

1. Remove the front door window regulator. Refer to [GW-16. "Front Door Glass Regulator"](#).
2. Remove door side grommet, and remove door key cylinder assembly (driver side) or outside handle escutcheon (passenger side) bolts (1) from grommet hole.

(2): Weatherstrip

#### CAUTION:

Do not forcibly remove the bolts (T30).

**Bolt**

**5.3 N·m (0.54 kg-m, 47 in-lb)**

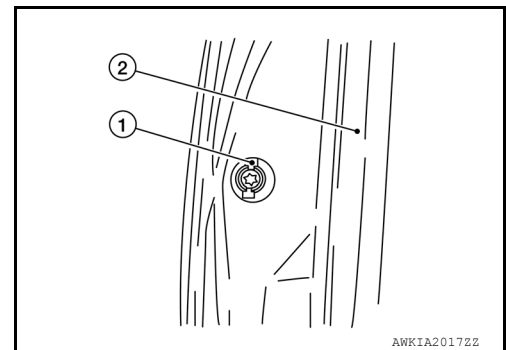

3. Separate the key cylinder rod from the key cylinder assembly.



# FRONT DOOR LOCK

## < REMOVAL AND INSTALLATION >

4. While pulling the outside handle (1), remove door key cylinder assembly or escutcheon (2).

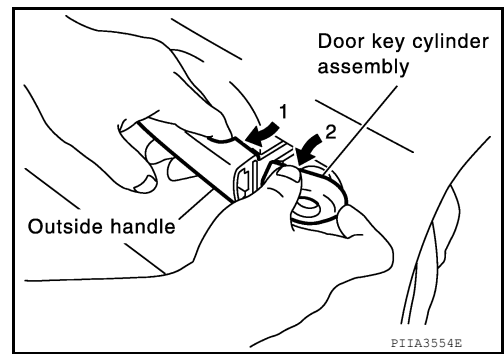

5. While pulling outside handle (2), slide toward rear of vehicle to remove outside handle (1).

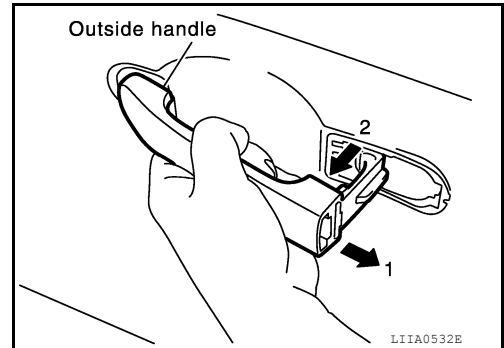

6. Remove the front gasket and rear gasket.

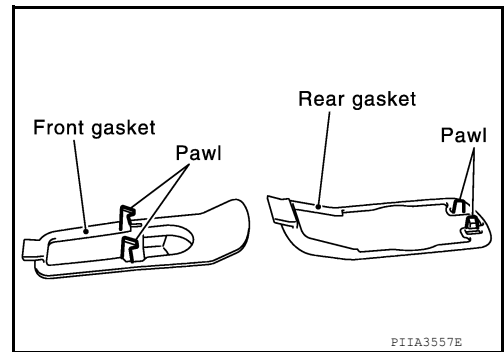

7. Remove the door lock assembly bolts (T30), remove the door lock assembly.

**CAUTION:**

**Do not reuse door lock assembly bolts.**

**Door lock assembly bolts 5.8 N·m (0.59 kg-m, 51 in-lb)**

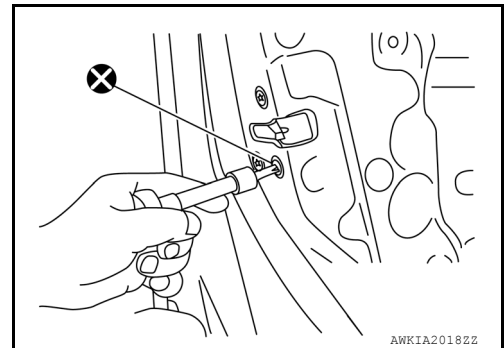

A  
B  
C  
D  
E  
F  
G  
H  
I  
J  
DLK  
L  
M  
N  
O  
P

# FRONT DOOR LOCK

## < REMOVAL AND INSTALLATION >

8. While pulling outside handle bracket, slide toward rear of vehicle to remove outside handle bracket and door lock assembly.

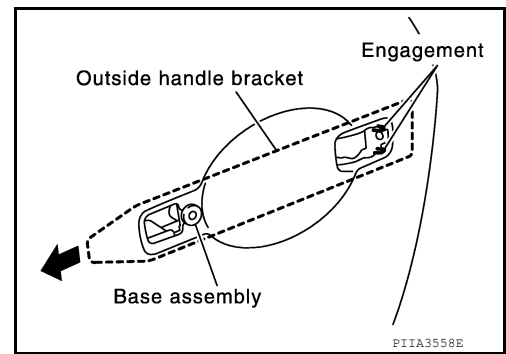

9. Disconnect the door lock actuator connector.
10. Separate the outside handle cable connection from the outside handle bracket.

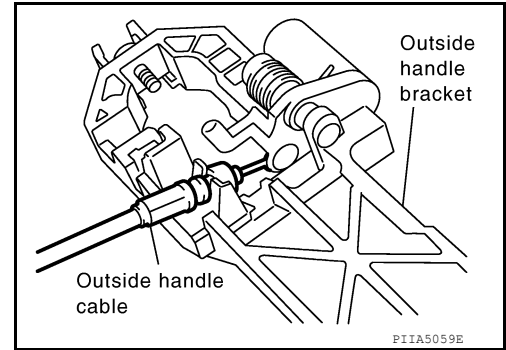

## INSTALLATION

Installation in the reverse order of removal.

### CAUTION:

To install each rod, be sure to rotate the rod holder until a click is felt.

## Disassembly and Assembly

INFOID:000000008792344

## DOOR KEY CYLINDER ASSEMBLY

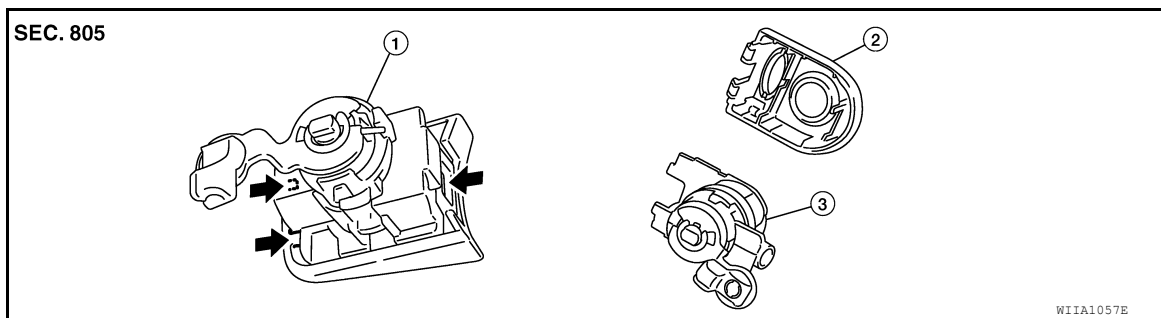

1. Door key cylinder assembly

2. Key cylinder escutcheon

3. Door key cylinder

4. Pawl

Remove the key cylinder escutcheon pawl and remove the door key cylinder.

# REAR DOOR LOCK

< REMOVAL AND INSTALLATION >

## REAR DOOR LOCK

### Component Structure

INFOID:000000008792345

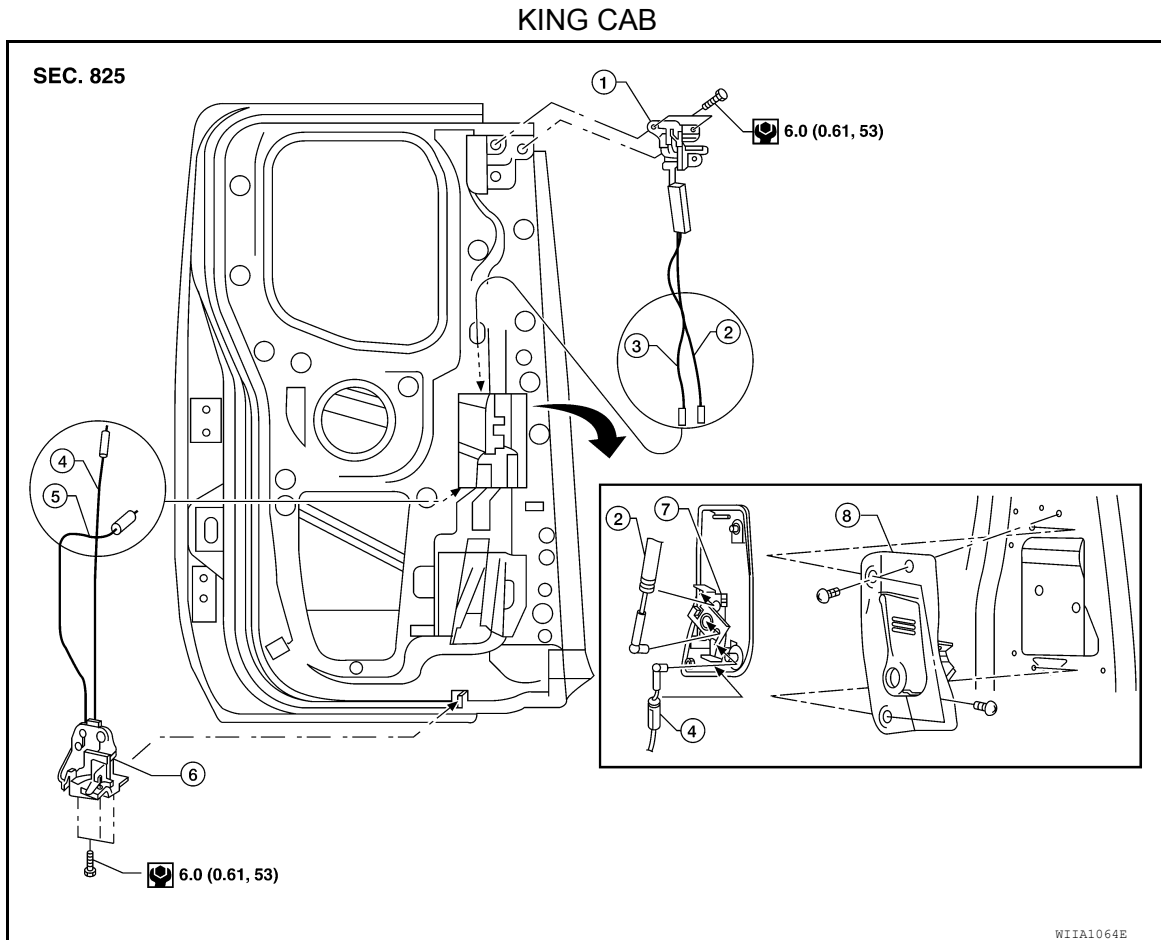

- |                            |                                   |                                   |
|----------------------------|-----------------------------------|-----------------------------------|
| 1. Rear upper door latch   | 2. Upper latch cable              | 3. Rear door switch upper harness |
| 4. Lower latch cable       | 5. Rear door switch lower harness | 6. Rear lower door latch          |
| 7. Rear door lock assembly | 8. Rear door handle               |                                   |

A  
B  
C  
D  
E  
F  
G  
H  
I  
J  
L  
M  
N  
O  
P

DLK

# REAR DOOR LOCK

< REMOVAL AND INSTALLATION >

CREW CAB

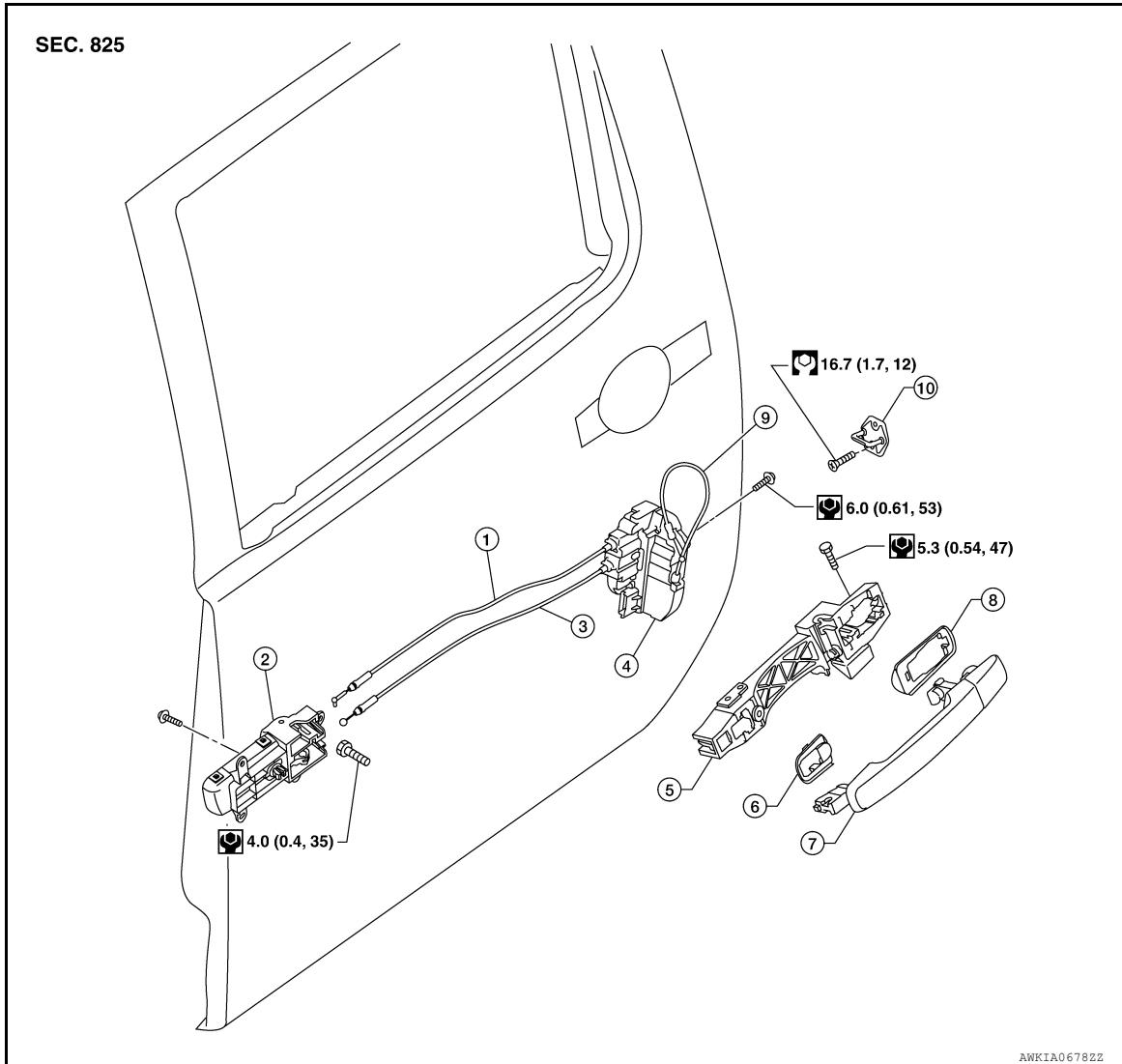

- |                            |                                     |                         |
|----------------------------|-------------------------------------|-------------------------|
| 1. Lock knob cable         | 2. Rear inside door handle assembly | 3. Inside handle cable  |
| 4. Rear door lock assembly | 5. Outside handle bracket           | 6. Front gasket         |
| 7. Outside handle          | 8. Rear gasket                      | 9. Outside handle cable |
| 10. Rear door striker      |                                     |                         |

## Removal and Installation

INFOID:000000008792346

### REMOVAL

1. Remove the rear door module assembly. Refer to [GW-20, "Rear Door Glass Regulator"](#).
2. Remove the door side grommet and the bolt (1) from the grommet hole.  
(2): Weatherstrip

**Bolt** : 5.3 N·m (0.54 kg-m, 47 in-lb)

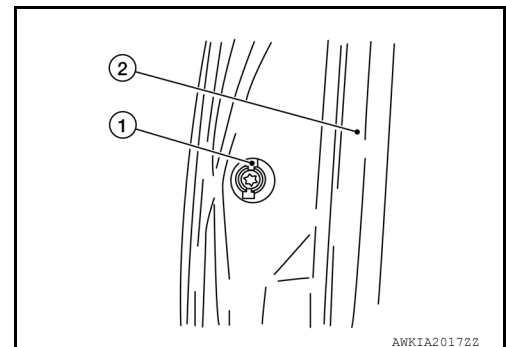

# REAR DOOR LOCK

## < REMOVAL AND INSTALLATION >

3. While pulling the outside handle (1), remove the door handle escutcheon (2).

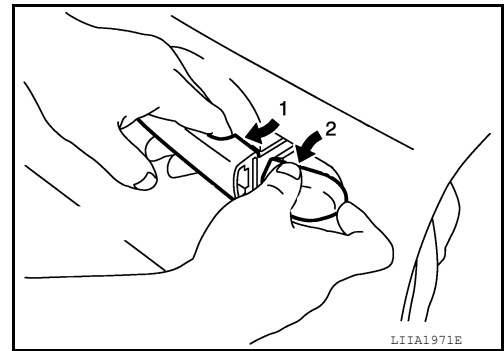

4. While pulling the outside handle (2), slide it toward the rear of vehicle to remove (1).

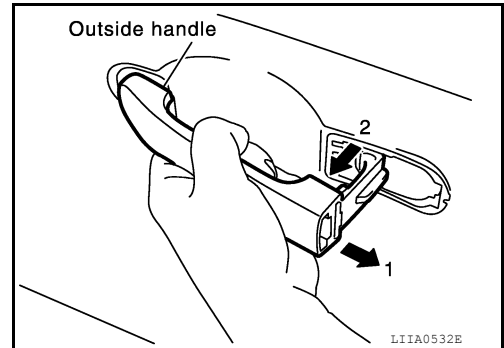

5. Remove the front and rear gaskets.

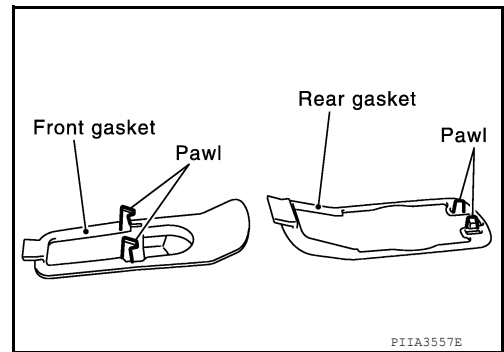

6. Remove the door lock assembly bolts (T30), remove the door lock assembly.

**CAUTION:**

**Do not reuse door lock assembly bolts.**

**Door lock assembly bolts : 5.8 N·m (0.59 kg-m, 51 in-lb)**

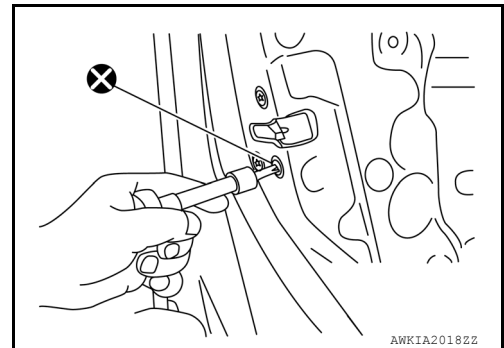

A  
B  
C  
D  
E  
F  
G  
H  
I  
J  
DLK  
L  
M  
N  
O  
P

## REAR DOOR LOCK

### < REMOVAL AND INSTALLATION >

7. While pulling outside handle bracket, slide toward rear of vehicle to remove outside handle bracket and door lock assembly.

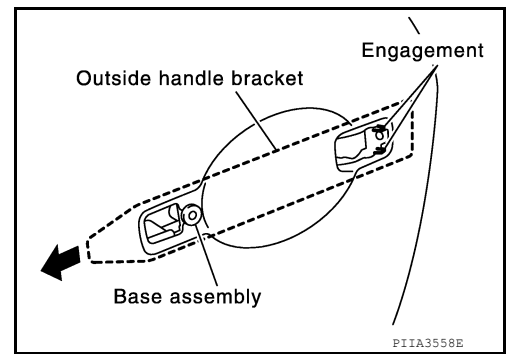

8. Disconnect the outside handle cable.

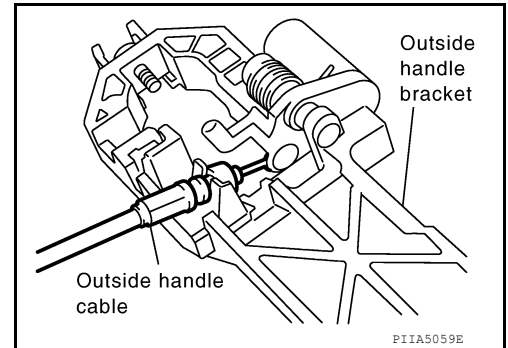

### INSTALLATION

Installation is in the reverse order of removal.

# TAIL GATE

< REMOVAL AND INSTALLATION >

## TAIL GATE

### Removal and Installation

INFOID:000000008792347

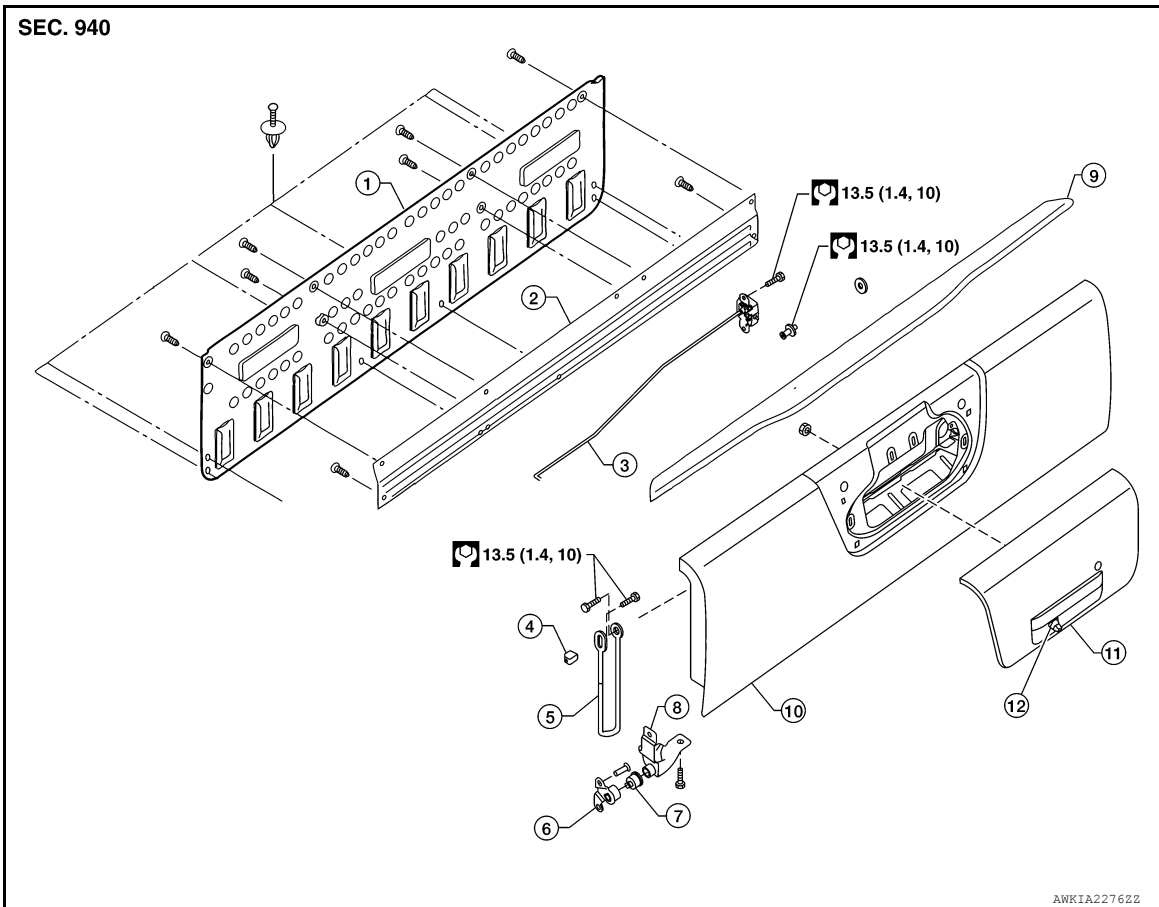

- |                                      |   |  |
|--------------------------------------|---|--|
| 1. Tail gate protector (if equipped) | 2. Tail gate cover plate                | 3. Tail gate latch assembly (LH/RH)            |
| 4. Tail gate rubber bumper           | 5. Tail gate stay assembly              | 6. Tail gate hinge assembly (LH/RH), body side |
| 7. Tail gate ring (LH)               | 8. Tail gate spoiler                    | 9. Tail gate hinge assembly (LH/RH), gate side |
| 10. Tail gate                        | 11. Tail gate handle and latch assembly | 12. Rear view camera (if equipped)             |

A  
B  
C  
D  
E  
F  
G  
H  
I  
J

DLK

L  
M  
N  
O  
P