

FOREWORD

This Body Repair Manual contains information and instructions for repairing the body structure of the 1998 NISSAN FRONTIER (D22) model. In order to achieve reliable repair work and ensure customer satisfaction, the technician should study this manual and become familiar with appropriate sections before starting repair and rebuilding work.

This Body Repair Manual is prepared for technicians who have attained a high level of skill and experience in repairing collision-damaged vehicles and also use modern service tools and equipment. Persons unfamiliar with body repair techniques should not attempt to repair collision-damaged vehicles by using this manual.

Technicians are also encouraged to read the 1998 NISSAN FRONTIER (D22) Service Manual and Body Repair Manual (Fundamentals) in order to ensure that the original functions and quality of the vehicle can be maintained. The Body Repair Manual (Fundamentals) contains additional information, including cautions and warnings, that are not included in this manual. Technicians should refer to both manuals to ensure proper repairs.

Please note that these manuals are prepared for worldwide usage, and as such, certain procedures might not apply in some regions or countries. In the U.S.A. it is recommended that a M.I.G. welder be used by a trained technician.

All information in this manual is based on the latest product information at the time of publication. The right is reserved to make changes in specifications and methods at any time without notice.

© 1997 NISSAN NORTH AMERICA, INC. Printed in U.S.A.

All rights reserved. No part of this Body Repair Manual may be reproduced or stored in a retrieval system, or transmitted in any form, or by any means, electronic, mechanical, photocopying, recording or otherwise, without the prior written permission of Nissan North America, Inc., Torrance, California.

CONTENTS

GENERAL INFORMATION	1
Identification Number	1
BODY COMPONENT PARTS	3
Underbody Component Parts	3
Body Component Parts	4
CORROSION PROTECTION	5
Description	5
Anti-Corrosive Wax	6
Undercoating	8
Stone Guard Coat	9
BODY CONSTRUCTION	10
Body Construction	10
BODY ALIGNMENT	12
Body Center Marks	12
Panel Parts Matching Marks	14
Description	16
Engine Compartment	17
Underbody	18
Passenger Compartment	22
Rear Body	25
HANDLING PRECAUTIONS FOR PLASTICS	26
Handling Precautions for Plastics	26
Location of Plastic Parts	27
REPLACEMENT OPERATIONS	29
Description	29
Radiator Core Support	30
Radiator Core Support (Partial Replacement)	31
Hoodledge (Partial Replacement)	32
Front Pillar	33
Lock Pillar	34
Outer Sill	36
Back Panel	37

Identification Number

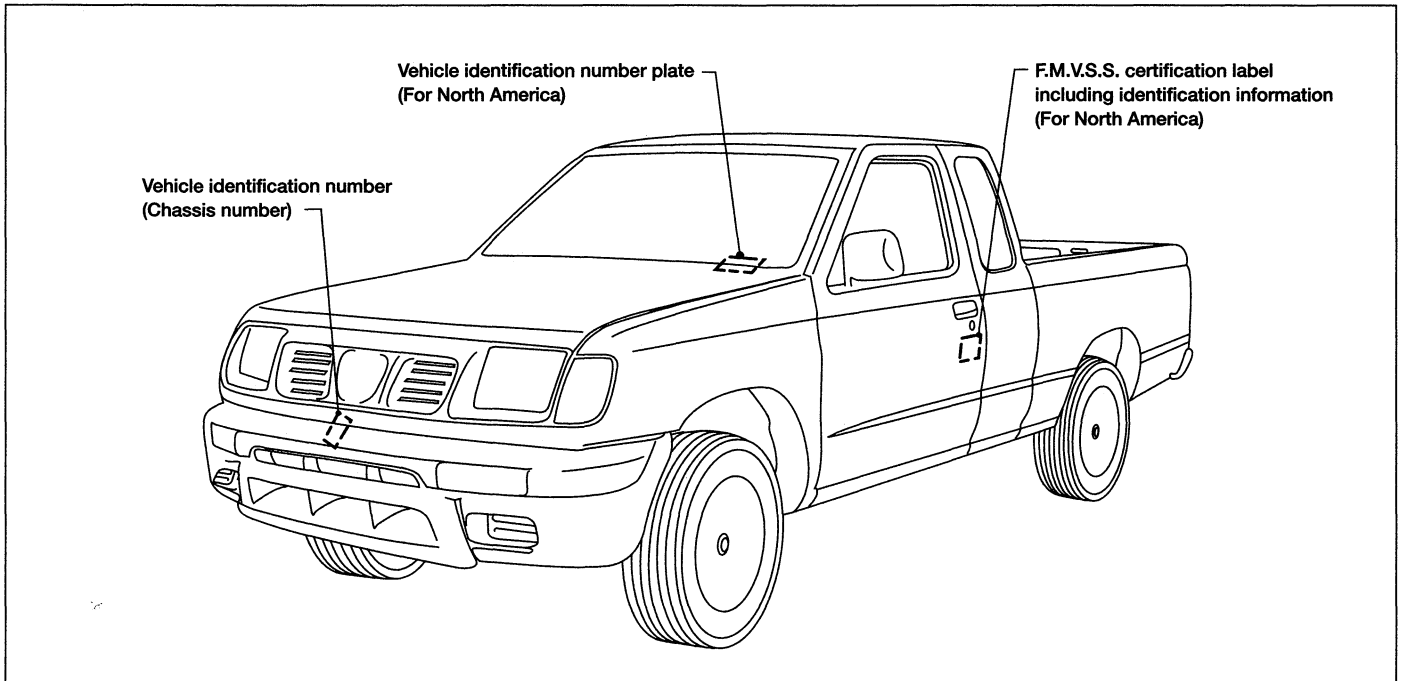

VEHICLE IDENTIFICATION NUMBER

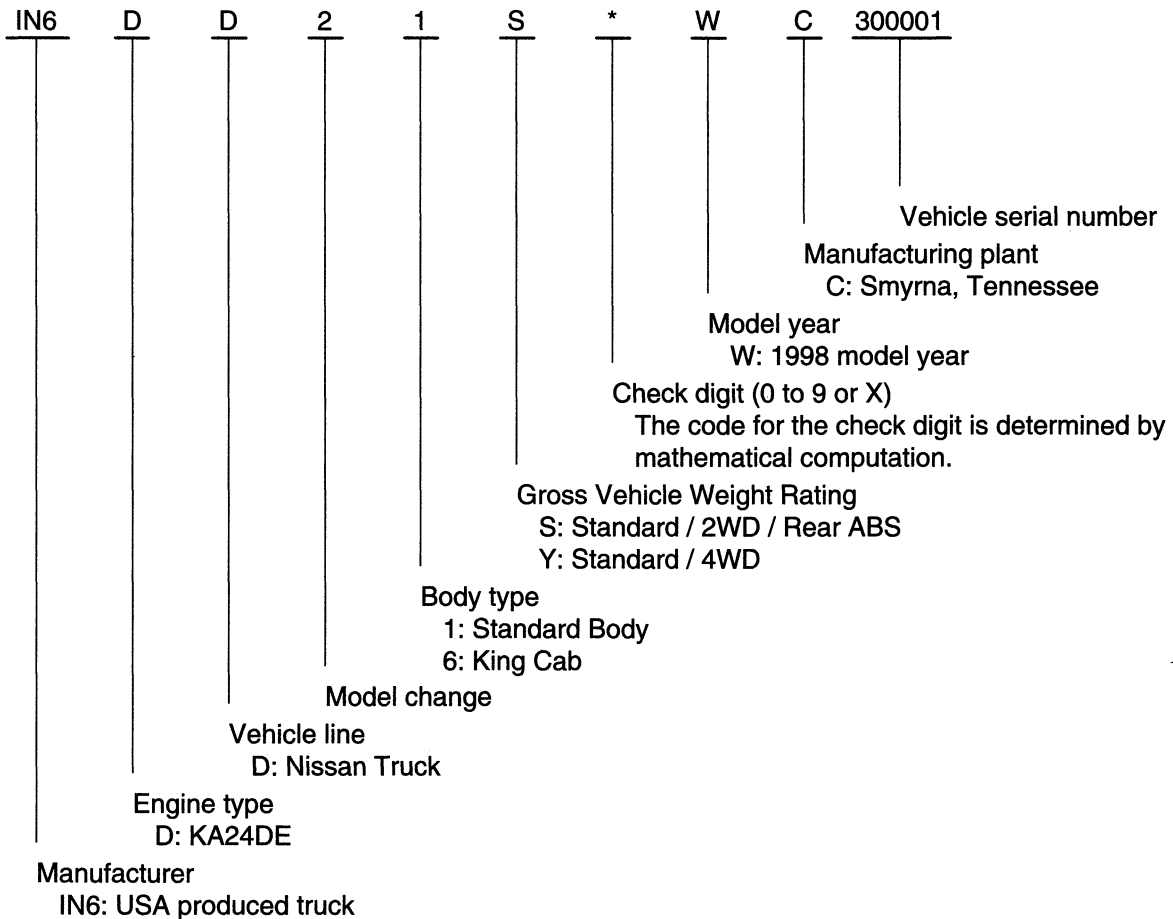

Prefix and suffix designations:
(For North America)



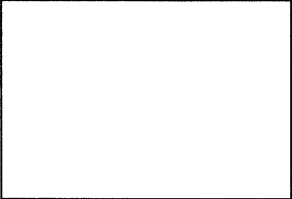

Identification Number (Cont'd)

F.M.V.S.S. CERTIFICATION LABEL

For U.S.A.

MFD BY NISSAN MOTOR CO. LTD		
DATE	MM/YY	
GWR		
GAWR FR.		
WITH		TIRES
	RIMS AT	PSI
COLD SINGLE		
GAWR RR.		
WITH		TIRES
	RIMS AT	PSI
COLD SINGLE		
		
VIN:		
TRUCK		
MODEL:		02000
COLOR	TRIM	TRANS
AXLE		ENGINE

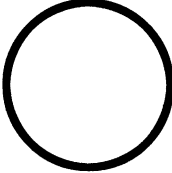
For Canada

MFD BY NISSAN MOTOR CO. LTD		
DATE	MM/YY	
GWR/PWBY		
GAWR/PWBE FR.		
WITH		TIRES
	RIMS AT	PSI
COLD SINGLE		
GAWR/PWBE RR.		
WITH		TIRES
	RIMS AT	PSI
COLD SINGLE		
		
VIN:		
TYPE: TRU/CAM		
MODEL:		02000
COLOR	TRIM	TRANS
AXLE		ENGINE

Underbody Component Parts

 : Indicates high strength steel (HSS) portions.
 * : Anti-corrosive pre-coated steel

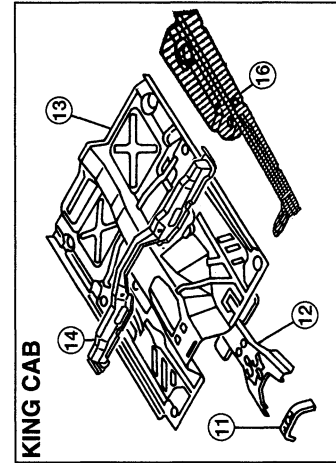
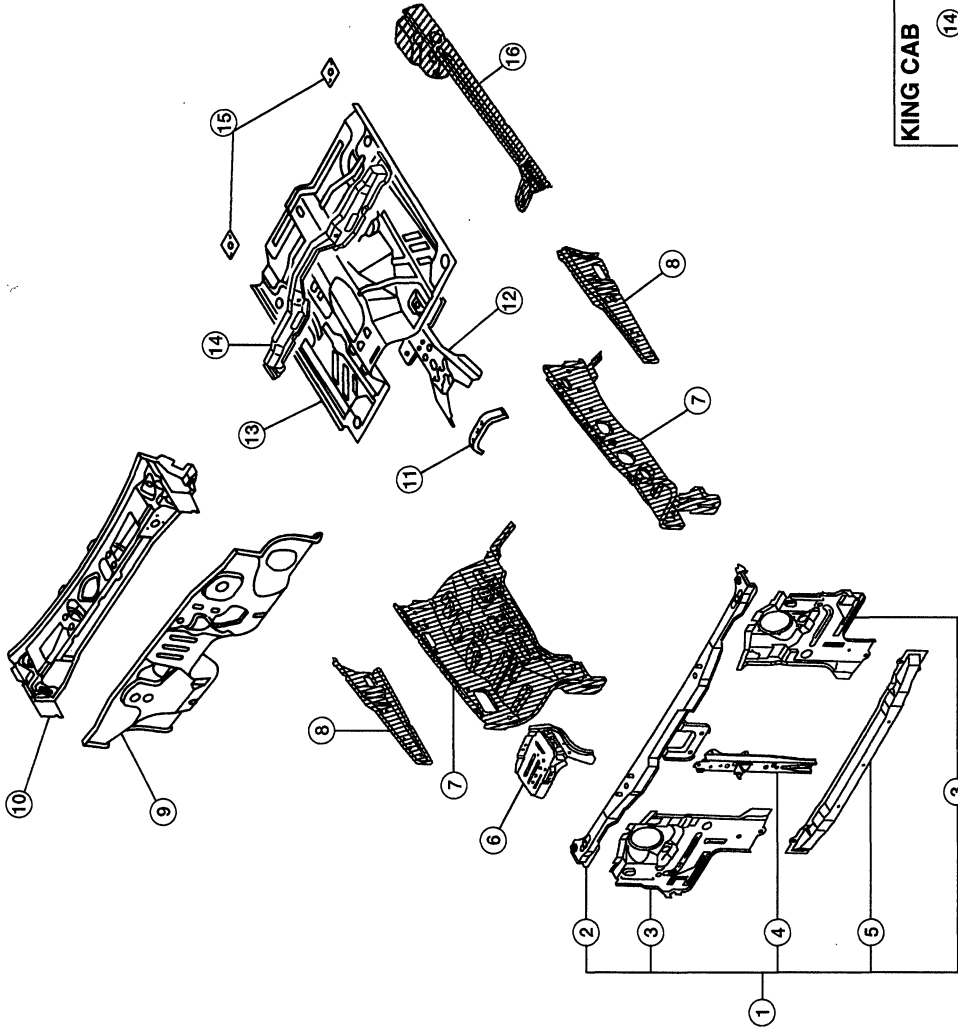

- | | |
|----------------------------------|--|
| 1 Radiator core support assembly | *9 Lower dash |
| *2 Upper radiator core support | *10 Air box assembly |
| *3 Side radiator core support | *11 Instrument stay reinforcement |
| 4 Hoodlock stay | *12 Parking brake and seat belt reinforcement assembly |
| 5 Lower radiator core support | *13 Front floor |
| 6 Battery support bracket | 14 2nd crossmember |
| *7 Hoodledge assembly | *15 Cab mount bracket assembly |
| *8 Hoodledge reinforcement | *16 Inner sill (L.H. & R.H.) |

Body Component Parts

 : Indicates high strength steel (HSS) portions.
 * : Anti-corrosive pre-coated steel

REGULAR CAB

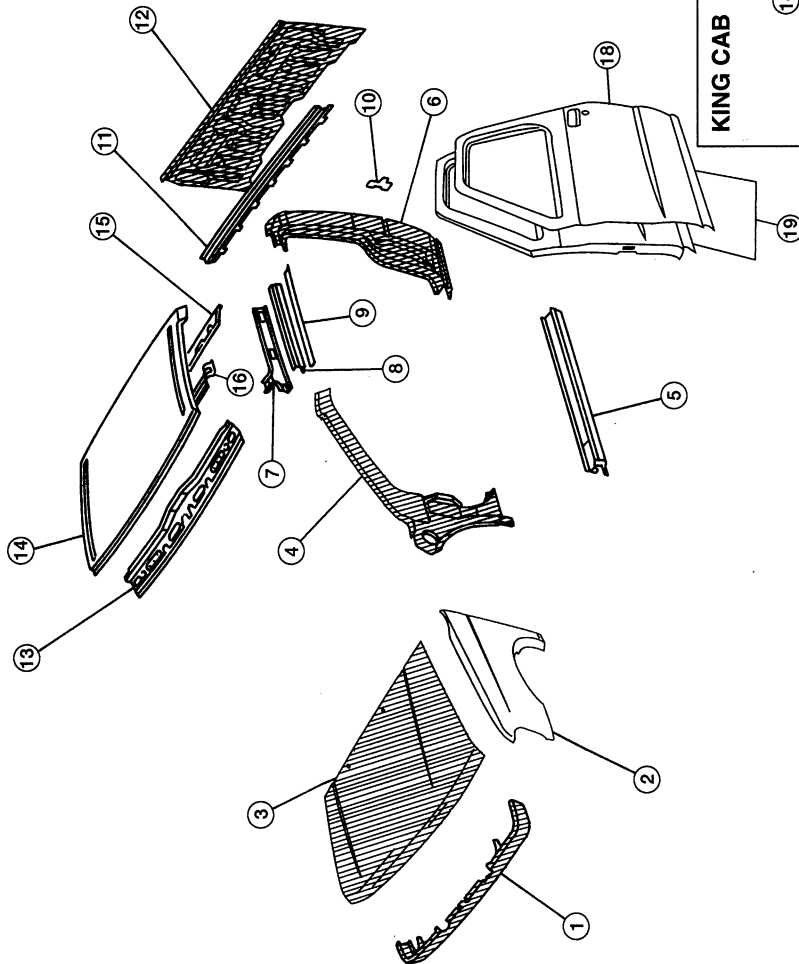

KING CAB

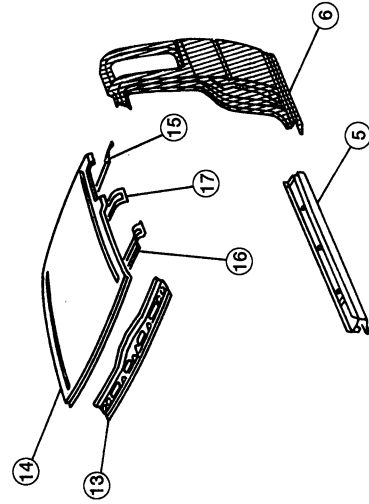

- *1 Front apron panel
- *2 Front fender (R.H. & L.H.)
- *3 Hood
- 4 Front pillar (R.H. & L.H.)
- *5 Outer sill (R.H. & L.H.)
- *6 Lock pillar (R.H. & L.H.)
- *7 Inner side roof rail (R.H. & L.H.)
- 8 Outer side roof rail (R.H. & L.H.)
- 9 Roof drip channel (R.H. & L.H.)
- 10 Striker plate
- 11 Back panel reinforcement
- 12 Back panel
- 13 Front roof rail
- 14 Roof
- 15 Rear roof rail
- 16 Roof bow No. 1
- 17 Roof bow No. 2
- *18 Outer front door (R.H. & L.H.)
- *19 Front door assembly (R.H. & L.H.)

Description

To provide improved corrosion prevention, the following anti-corrosive measures have been implemented in our production plants. When repairing or replacing body panels, it is necessary to use these same anti-corrosive measures.

ANTI-CORROSIVE PRECOATED STEEL (DURASTEEL)

To improve reparability and corrosion resistance, a new type of anti-corrosive pre-coated steel sheet has been adopted replacing conventional zinc-coated steel sheet. Durasteel is electroplated zinc-nickel alloy under organic film, which provides excellent corrosion resistance.

Durasteel is classified as either one-side pre-coated steel or two-side pre-coated steel. The two-side pre-coated steel provides excellent corrosion resistance.

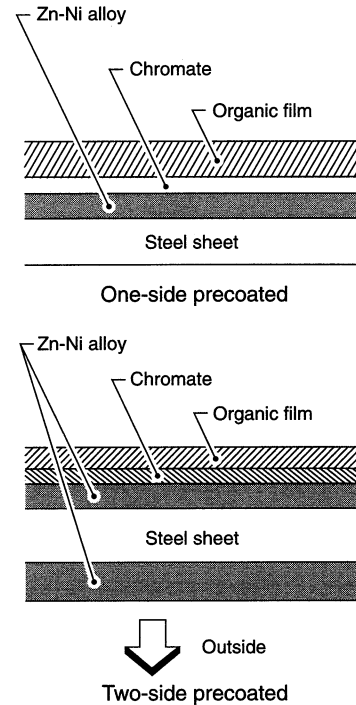

Nissan Genuine Service Parts are fabricated from durasteel sheets. Therefore, it is recommended that GENUINE NISSAN PARTS or equivalent be used for panel replacement to maintain the anti-corrosive performance built into the vehicle at the factory.

PHOSPHATE COATING TREATMENT AND CATIONIC ELECTRODEPOSITION PRIMER

A phosphate coating treatment and a cationic electrodeposition primer, which provide excellent corrosion protection, are employed on all body components.

Caution:

Confine paint removal during welding operations to an absolute minimum.

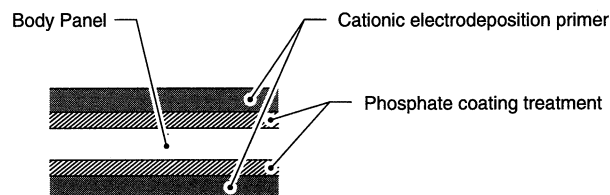

Nissan Genuine Service Parts are also treated in the same manner. Therefore, it is recommended that GENUINE NISSAN PARTS or equivalent be used for panel replacement to maintain anti-corrosive performance built into the vehicle at the factory.

Anti-Corrosive Wax

To improve corrosion resistance, anti-corrosive wax is applied inside the body sill and inside other closed sections. Accordingly, when replacing these parts, be sure to apply anti-corrosive wax to the appropriate areas of the new parts. Select an excellent anti-corrosive wax which will penetrate after application and has a long shelf life.

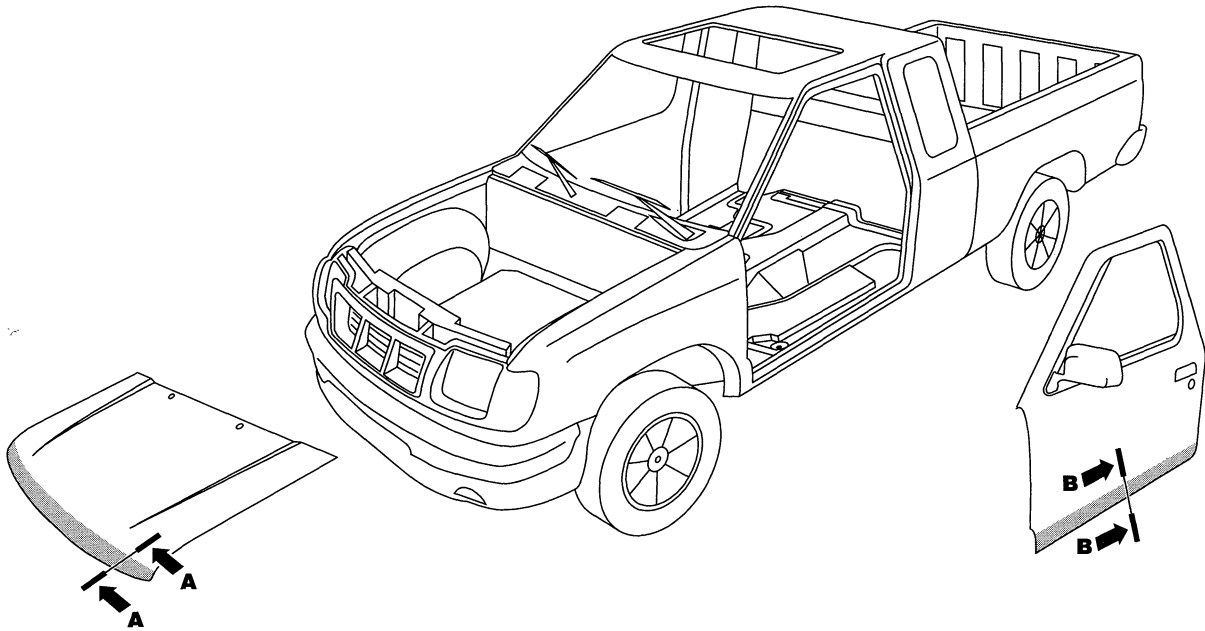

 : Indicates anti-corrosive wax coated portions.

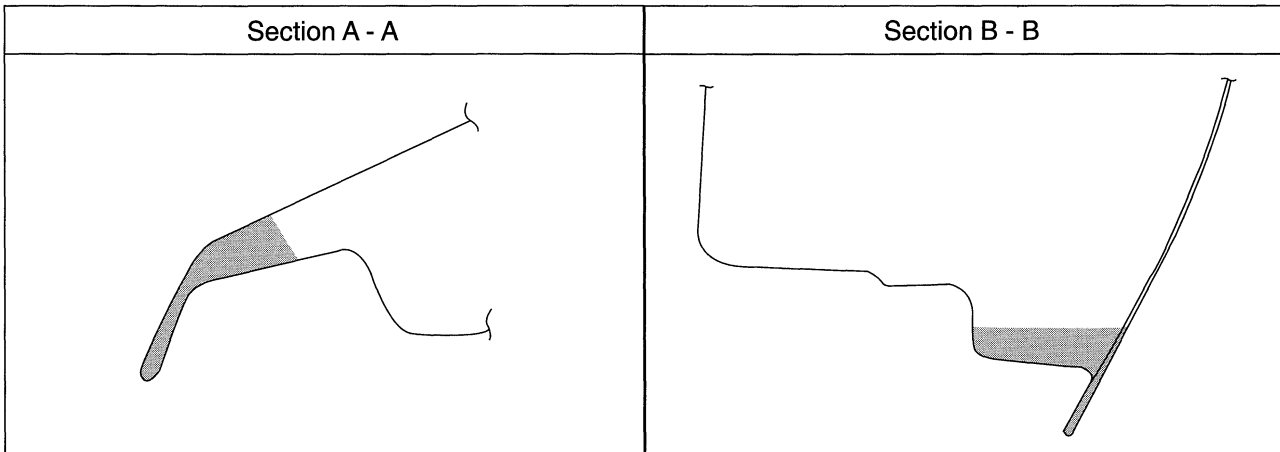

Anti-Corrosive Wax (Cont'd)

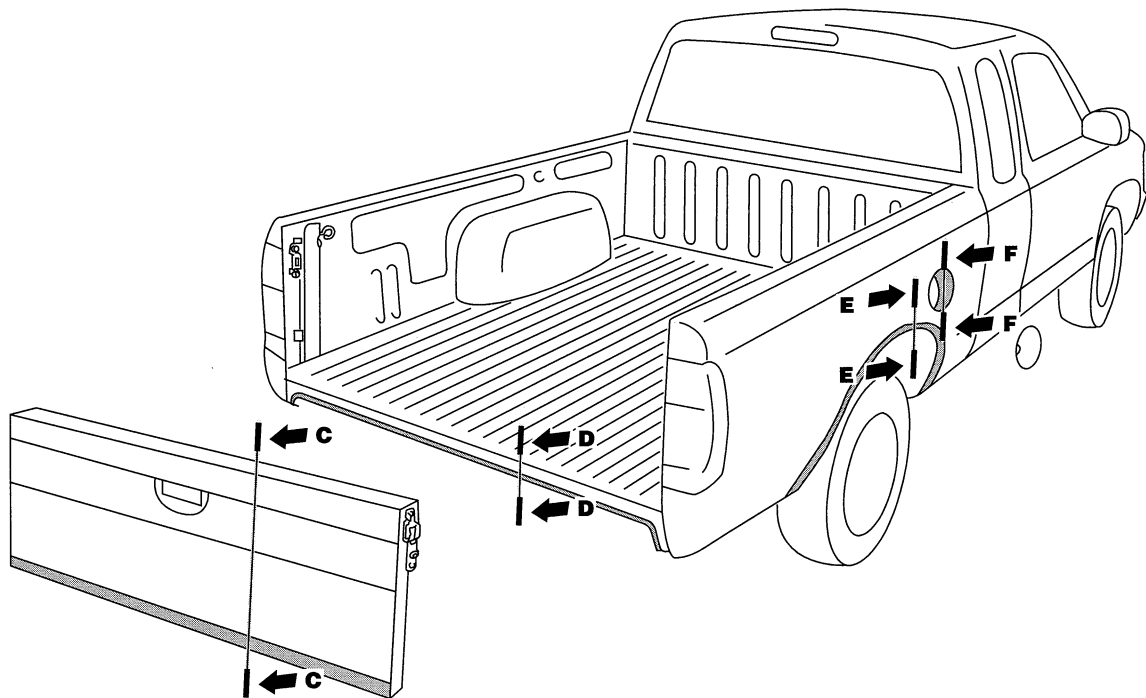

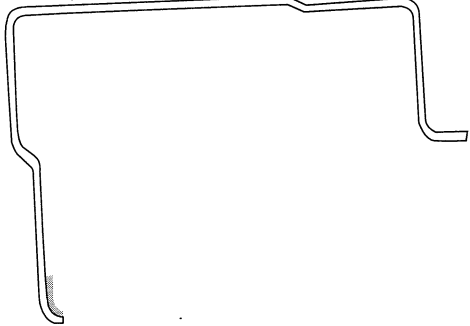
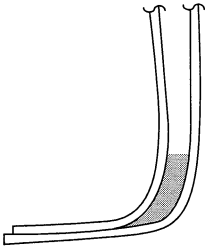
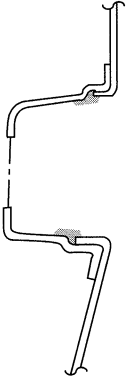
Section C - C	Section D - D
	
Section E - E	Section F - F
	

Undercoating

The underside of the floor and wheelhouse are undercoated to prevent rust, vibration, noise and stone chipping. Therefore, when such a panel is replaced or repaired, apply undercoating to that part. Use an undercoating with the following properties: rust preventive, soundproofing, vibration-proofing, shock-resistant, adhesive, and durable.

Precaution in undercoating

1. Do not apply undercoating to any place unless specified (such as the areas above the muffler and three-way catalytic converter which are subjected to heat).
2. Do not undercoat the exhaust pipe or other parts which become hot.
3. Do not undercoat rotating parts.
4. Apply bitumen wax after applying undercoating.

 : Indicates undercoated portions.

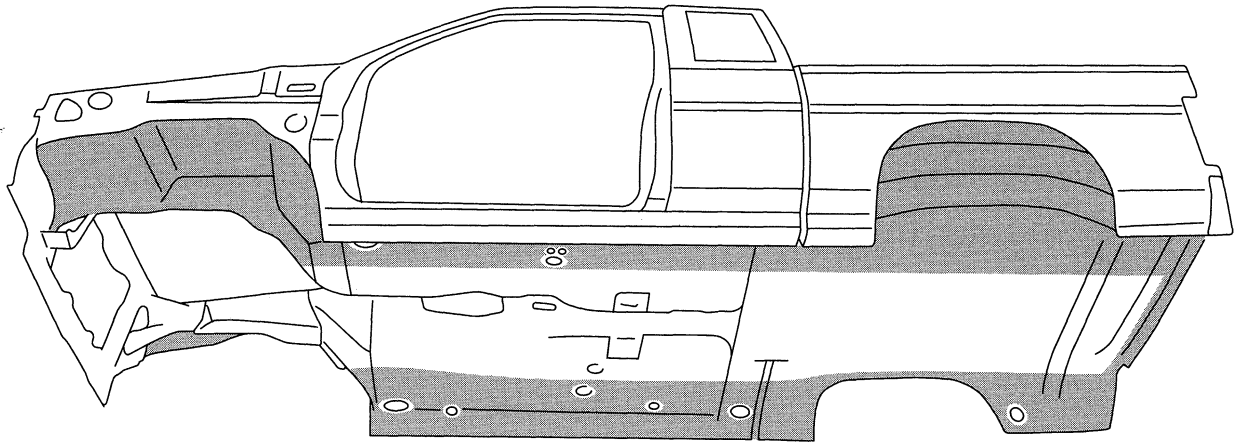

Stone Guard Coat

To prevent damage caused by stones, the lower outer body panel (fender, door, etc.) have an additional layer of Stone Guard coating over the ED primer coating. When replacing or repairing these panels, apply Stone Guard coating to the same portions as before. Use a coating which is rust preventive, durable, shock-resistant and has a long shelf life.

 : Indicates Stone Guard coated portions. (All trucks)

 : Indicates Stone Guard coated portions. (4WD only)

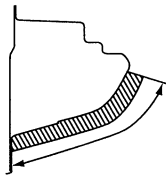
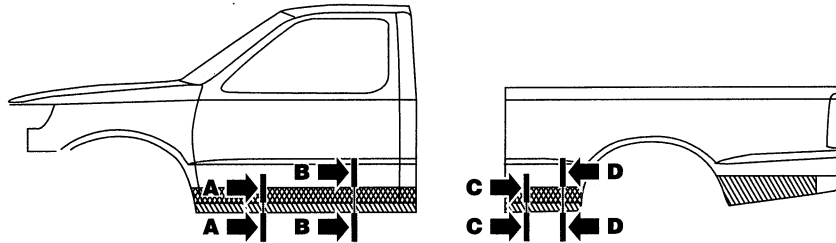

Section A-A

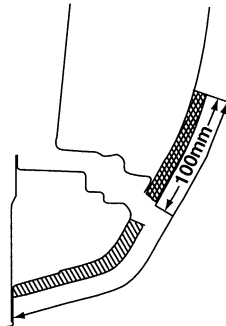
Section B-B
(4WD only)

Section C-C

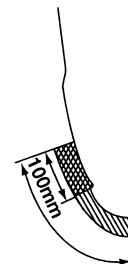
Section D-D
(4WD only)

Body Construction

Standard Cab

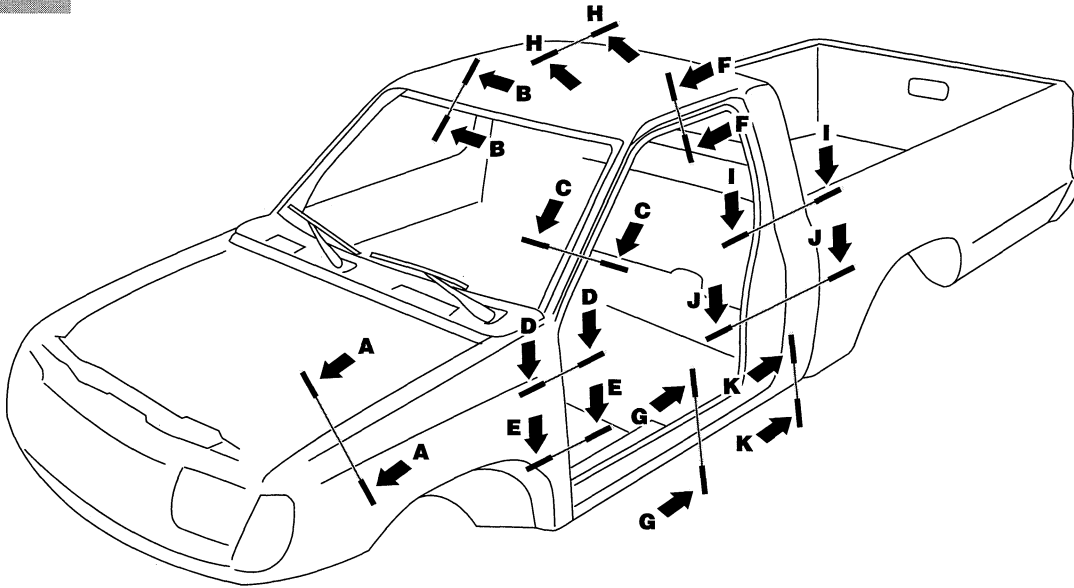

Section A - A	Section B - B	Section C - C	Section D - D
Section E - E	Section F - F	Section G - G	Section H - H
Section I - I	Section J - J	Section K - K	

Body Construction (Cont'd)

King Cab

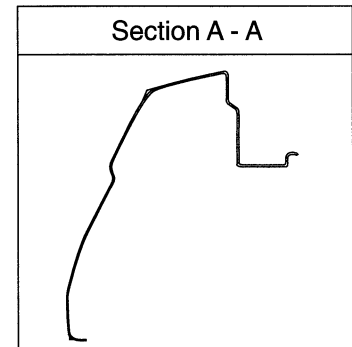
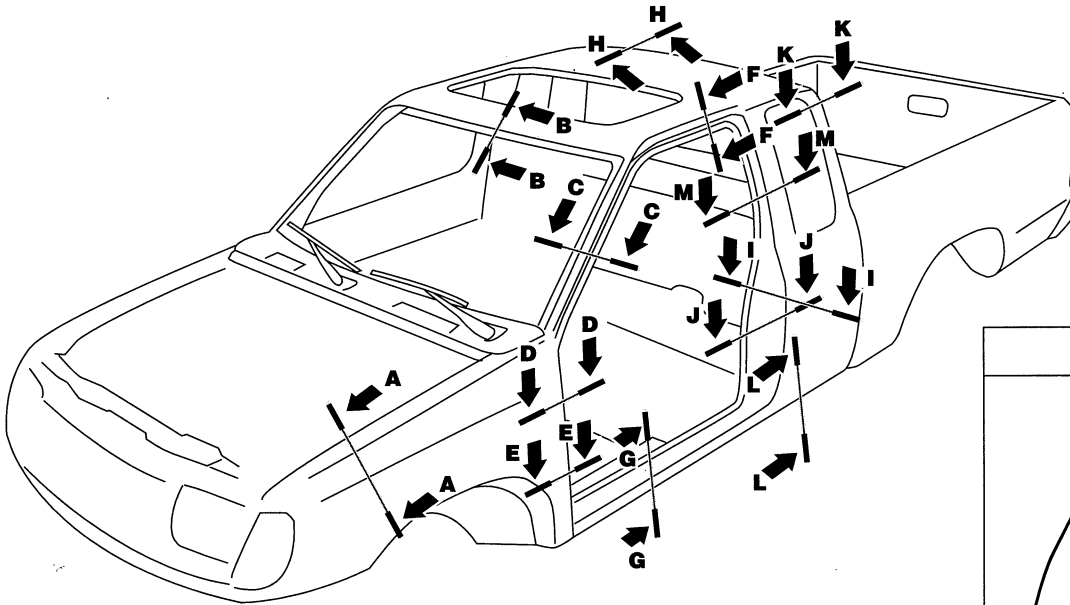

Section B - B	Section C - C	Section D - D	Section E - E
Section F - F	Section G - G	Section H - H	Section I - I
Section J - J	Section K - K	Section L - L	Section M - M

Body Center Marks

A mark has been placed on each part of the body to indicate the vehicle center. When repairing parts damaged by an accident which might affect the vehicle frame (members, pillars, etc.) more accurate, effective repair will be possible by using these marks together with body alignment data.

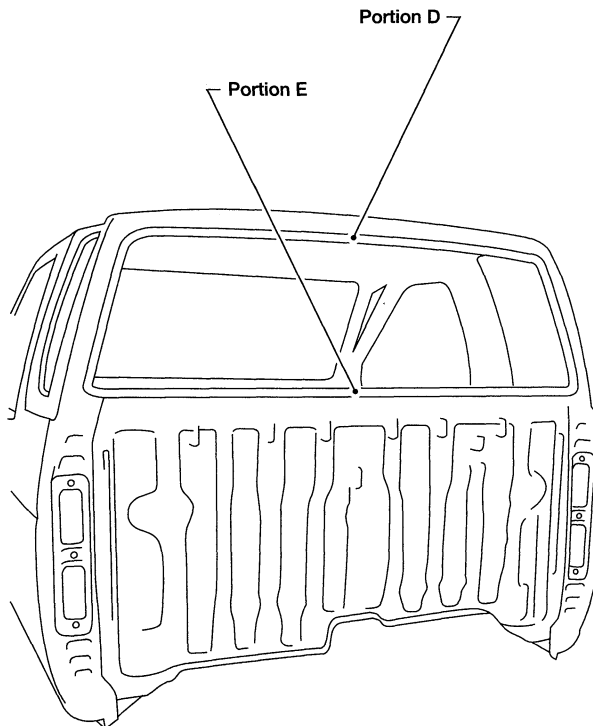
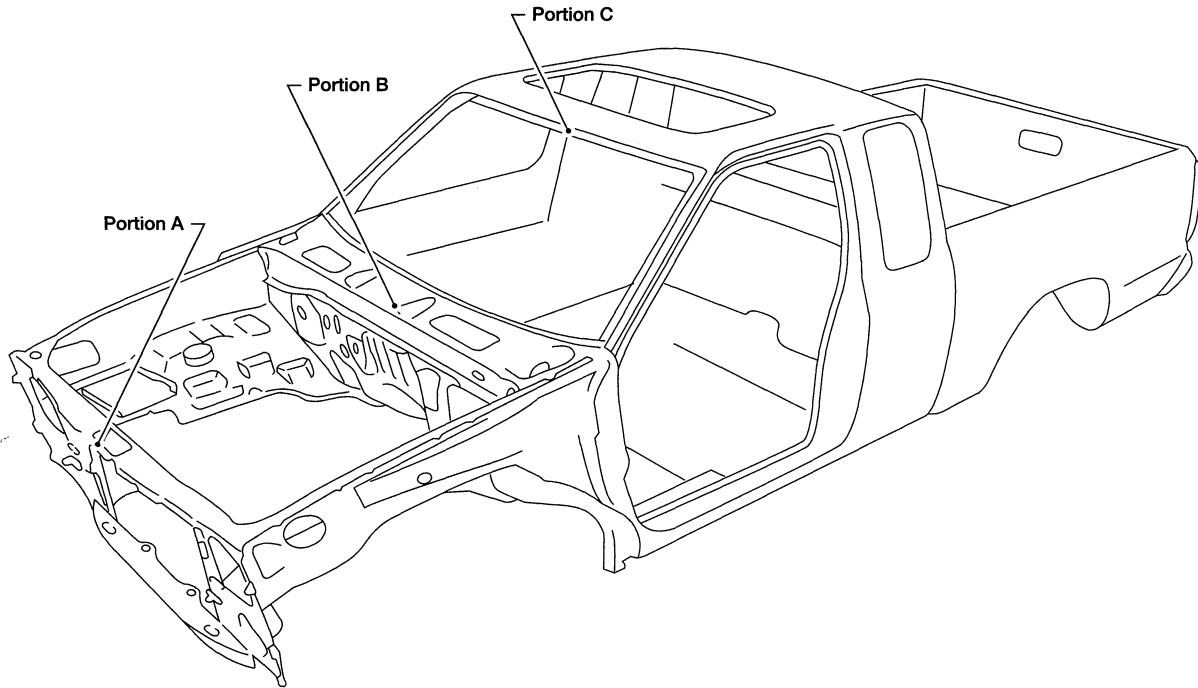

Body Center Marks (Cont'd)

Unit: mm

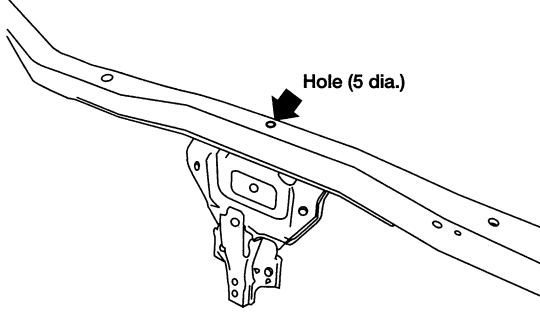
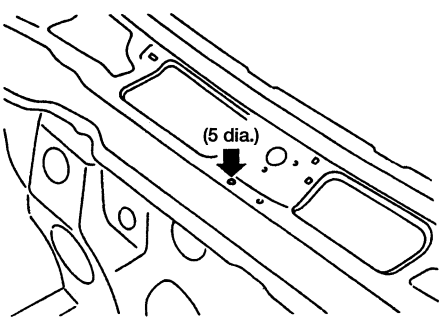
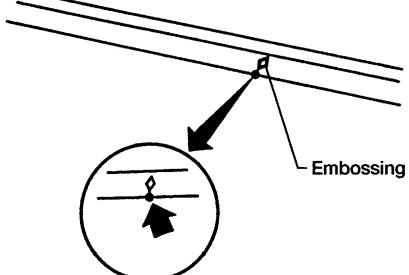
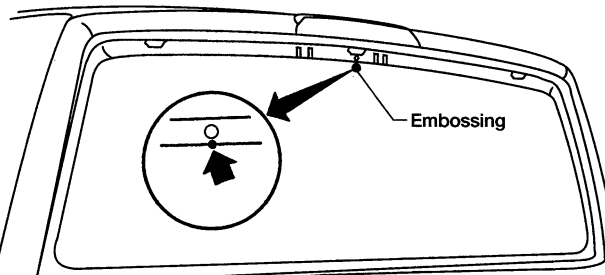
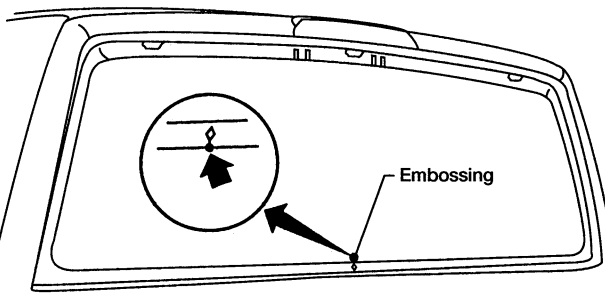
Portion A	Portion B
 <p data-bbox="142 709 406 735">● Upper radiator core support</p>	 <p data-bbox="771 709 868 735">● Cowl top</p>
Portion C	Portion D
 <p data-bbox="142 1155 243 1180">● Front roof</p>	 <p data-bbox="771 808 868 833">● Rear roof</p>
Portion E	
 <p data-bbox="142 1255 251 1281">● Rear panel</p>	

Panel Parts Matching Marks

A mark has been placed on each body panel to indicate the parts' matching positions. When repairing parts damaged by an accident which might affect the vehicle structure (members, pillars, etc.) more accurate, effective repair will be possible by using these marks together with body alignment specifications.

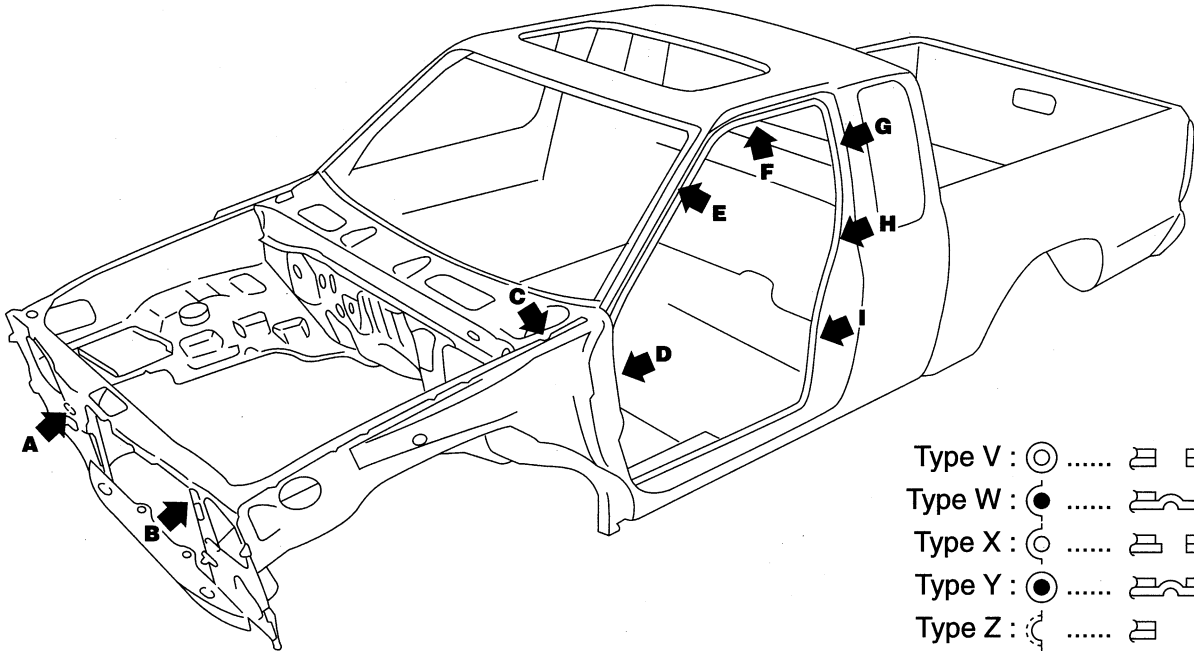

- Type V : ○ ▢ ▢
- Type W : ● ▢ ▢
- Type X : ○ ▢ ▢
- Type Y : ● ▢ ▢
- Type Z : ◌ ▢

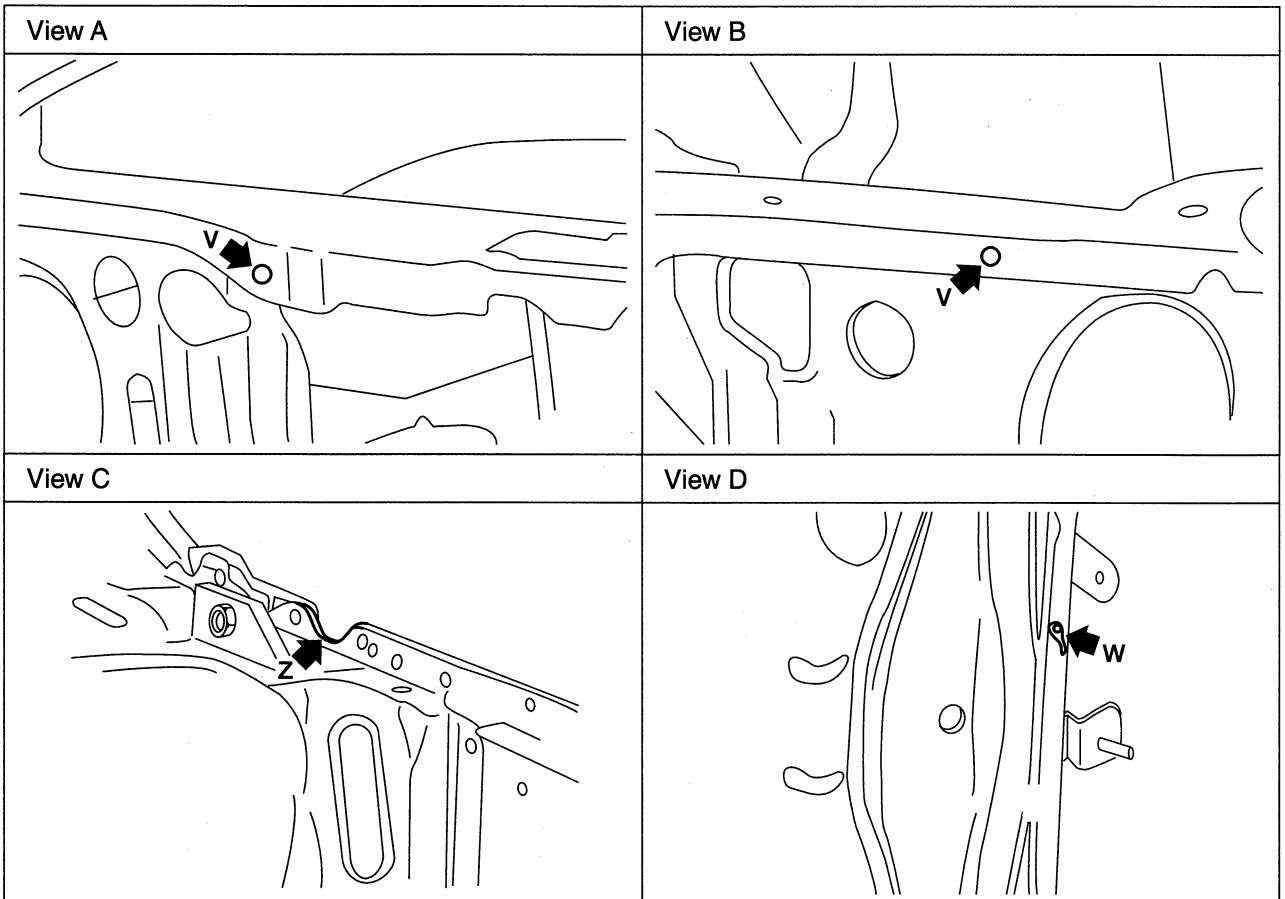

Panel Parts Matching Marks (Cont'd)

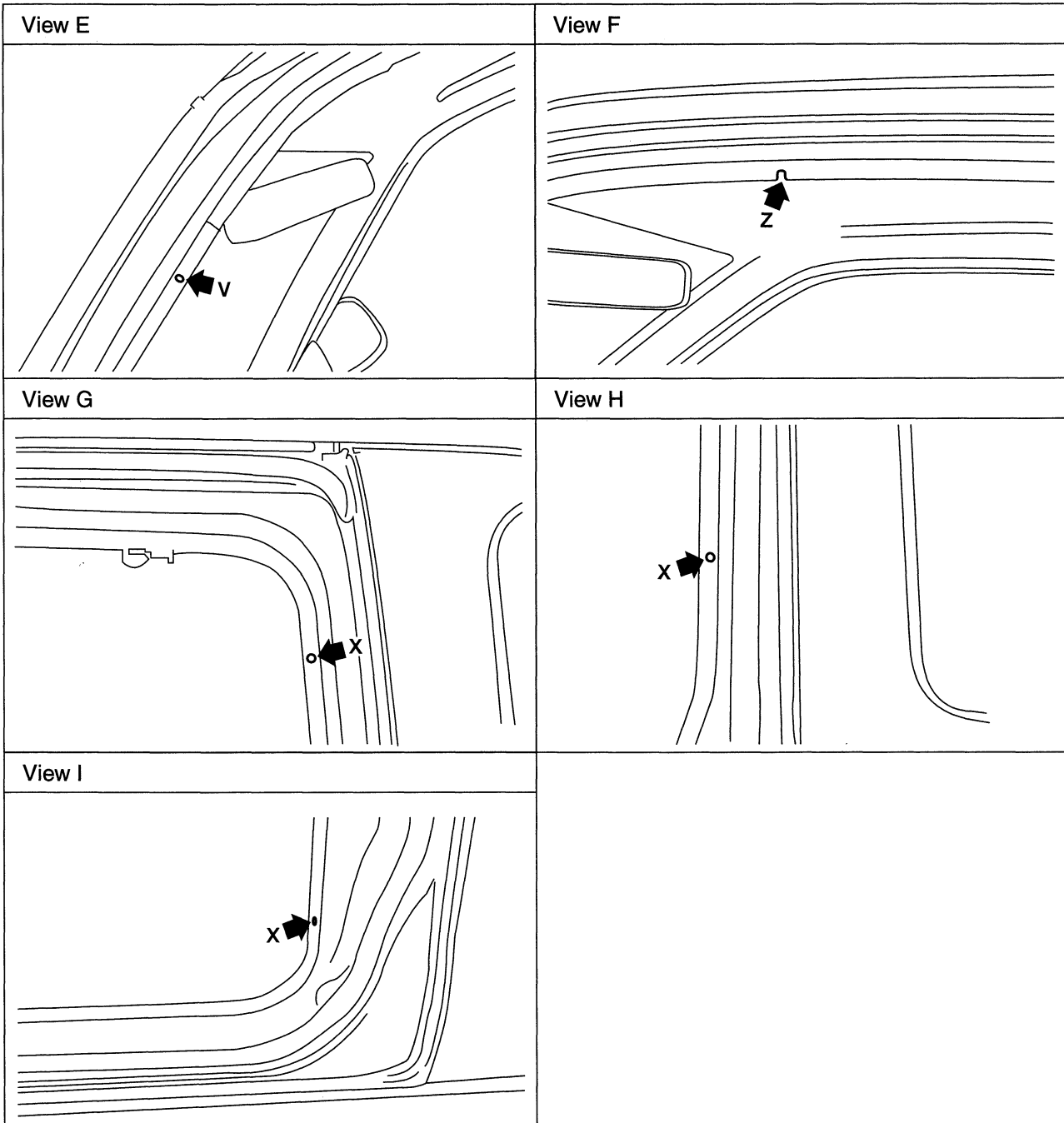

Description

- All dimensions indicated in the figures are actual.
- When using a tracking gauge, adjust both pointers to equal length. Then check the pointers and the gauge to make sure there is no free play.
- When a measuring tape is used, check to be sure there is no elongation, twisting or bending.
- Measurements should be taken at the center of the mounting holes.
- An asterisk (*) following the value at the measuring point indicates that the measuring point on the other side is symmetrically the same value.
- The coordinates of the measurement points are the distances measured from the standard line of "X", "Y" and "Z".

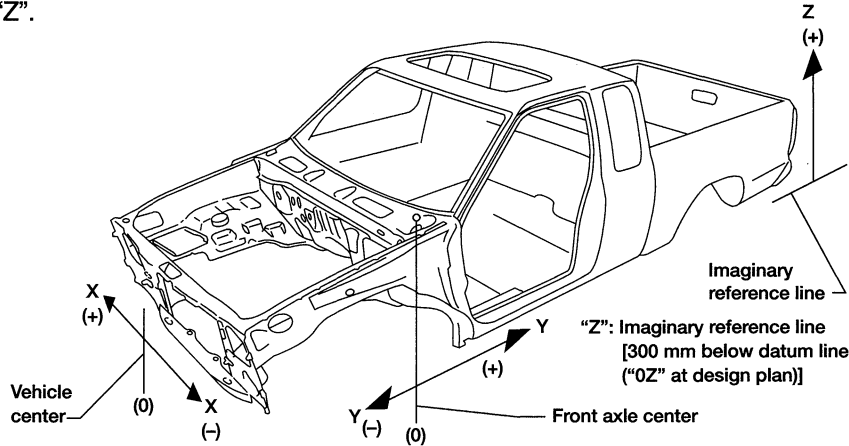

Engine Compartment

MEASUREMENT

Unit: mm

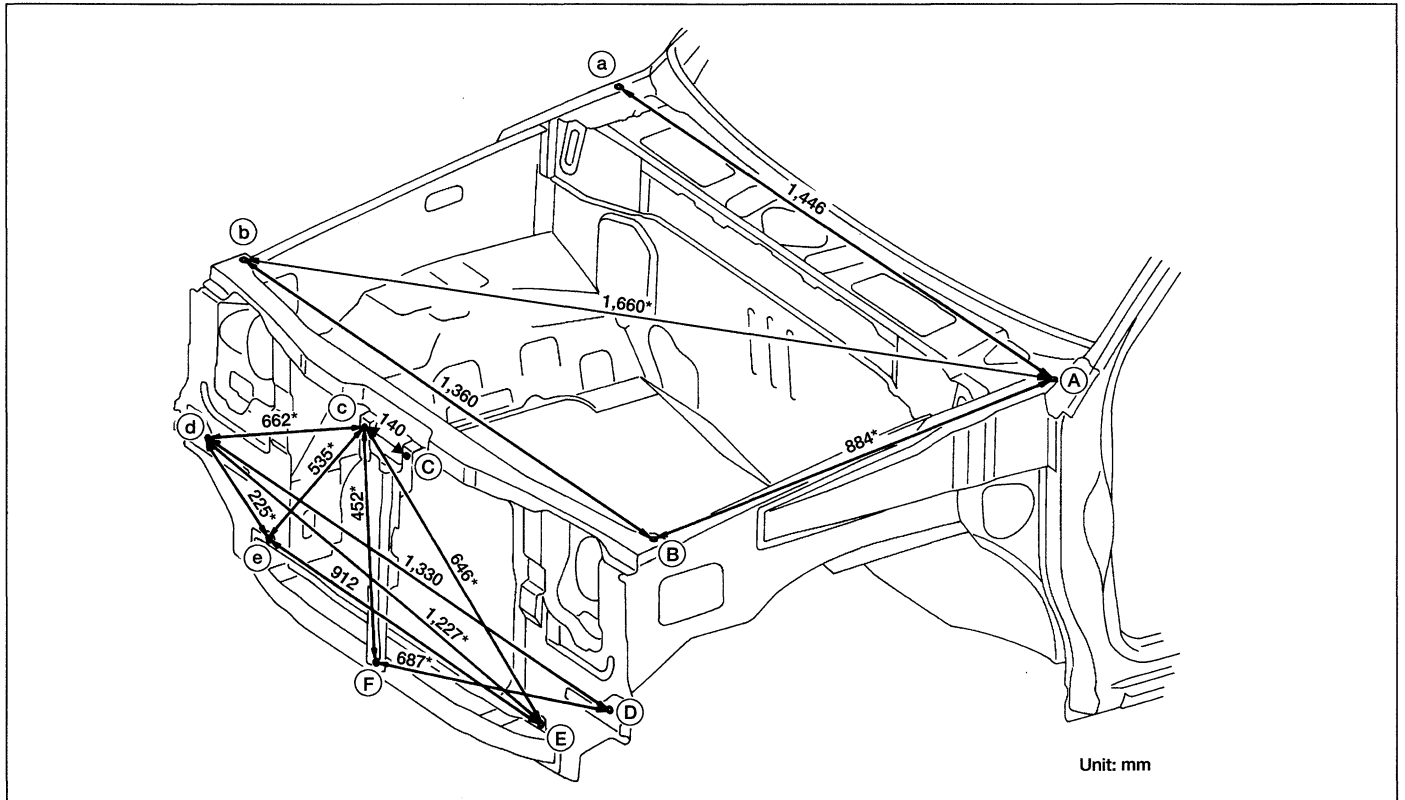

Engine Compartment

MEASUREMENT POINTS

Unit: mm

Cowl top side : (A)

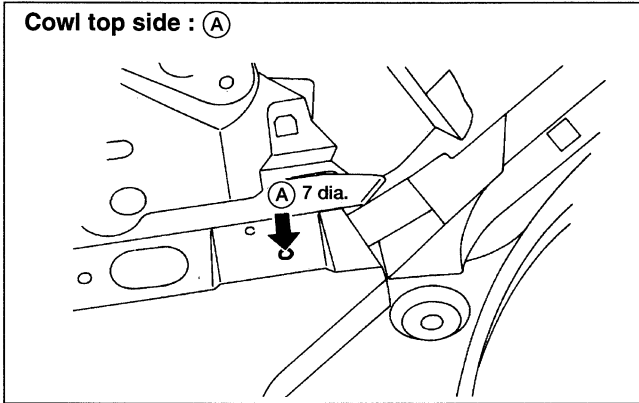

Radiator core support upper : (B)

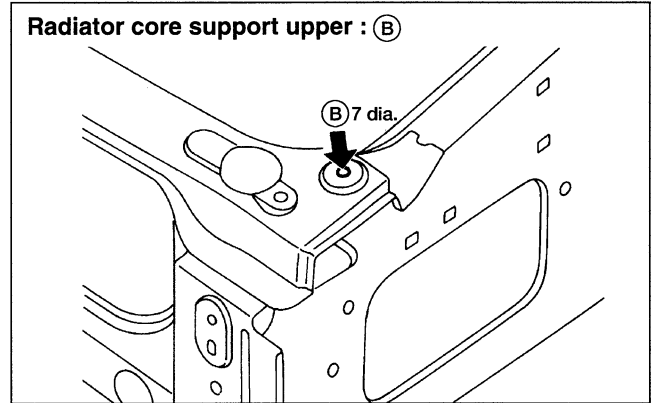

Hood lock stay : (C) (C)

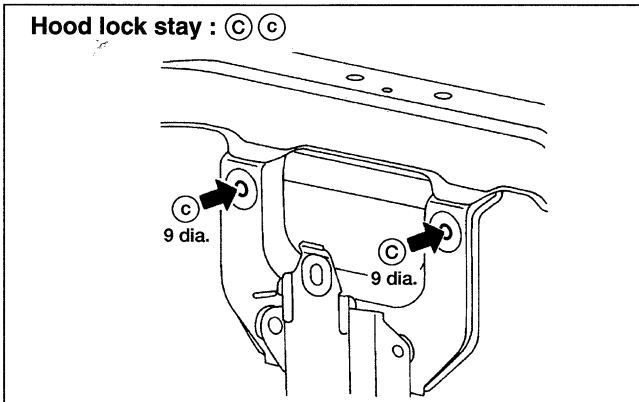

Radiator core support side : (D)

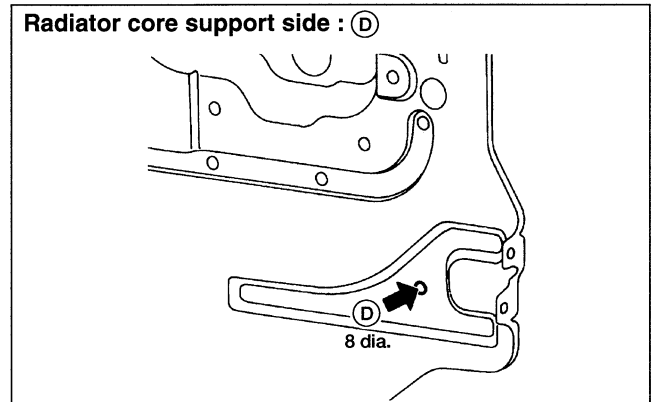

Radiator core support lower : (E)

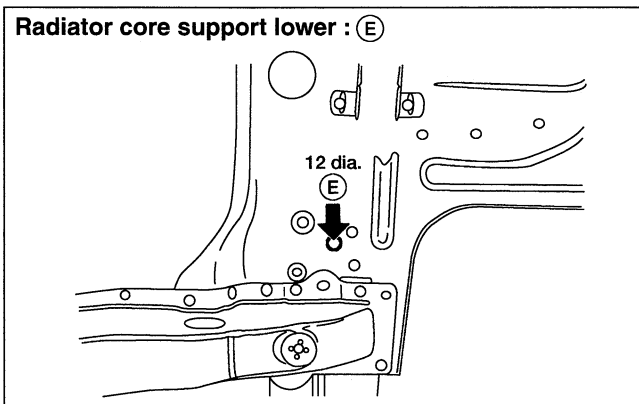

Hood lock stay : (F)

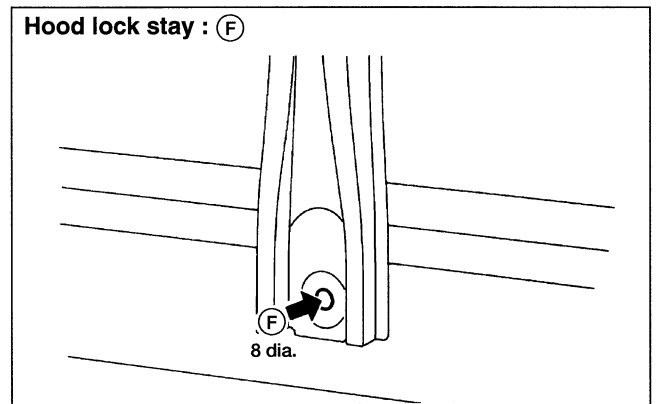

Underbody

SHORT WHEELBASE

MEASUREMENT

2WD model shown

Unit: mm

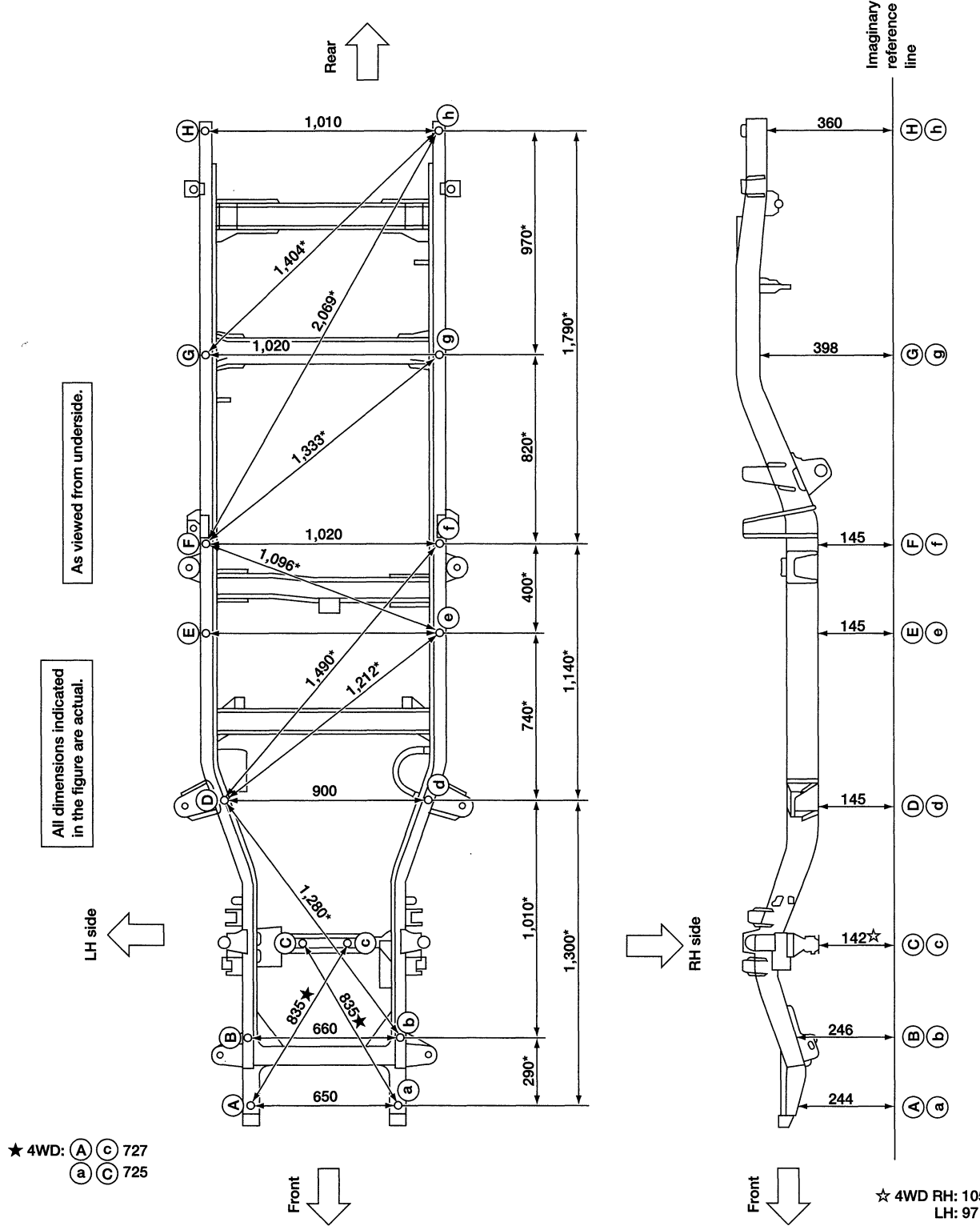

Underbody (Cont'd)

SHORT WHEELBASE

MEASUREMENT POINTS

Unit: mm

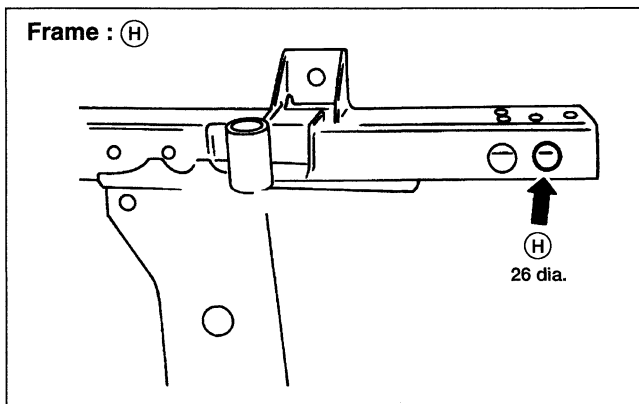
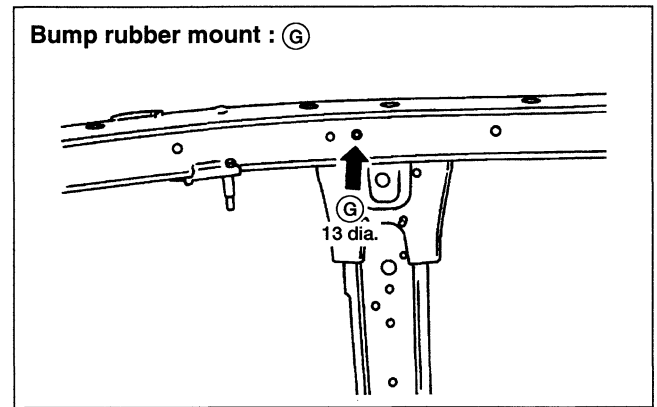
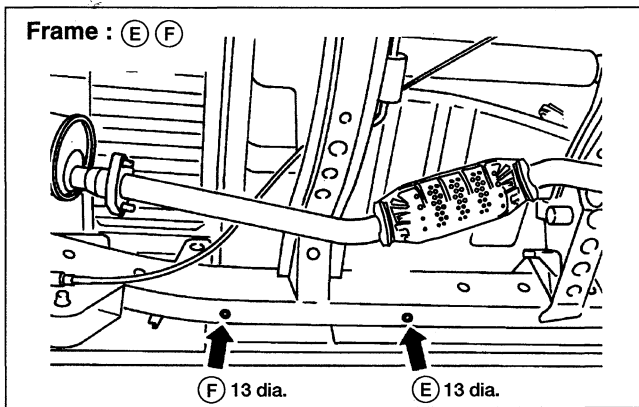
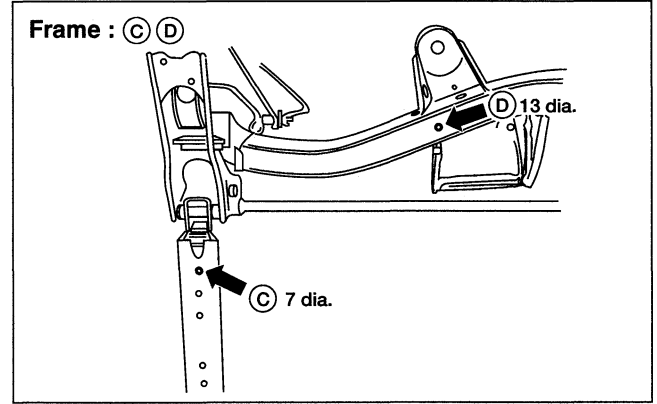
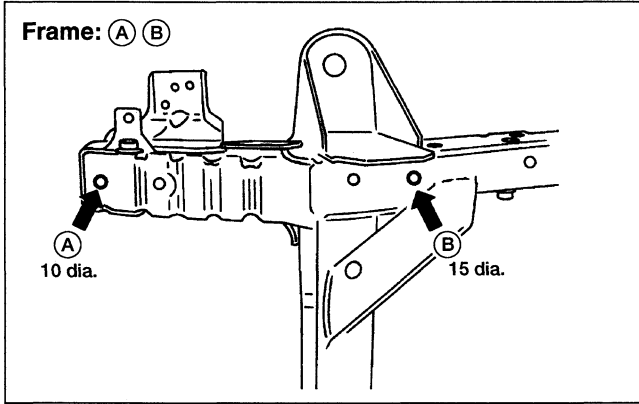

Coordinates:

(A), (a)	(E), (e)
X : 325	X : 510
Y : -700	Y : 1,340
Z : 244	Z : 145
(B), (b)	(F), (f)
X : 330	X : 510
Y : -409	Y : 1,740
Z : 246	Z : 145
(C), (c)	(G), (g)
X : 123	X : 510
Y : -3	Y : 2,560
Z : 4WD RH 105	Z : 398
4WD LH 97	(H), (h)
2WD 142	X : 505
(D), (d)	Y : 3,530
X : 450	Z : 360
Y : 600	
Z : 145	

Unit: mm

Underbody (Cont'd)

LONG WHEELBASE

MEASUREMENT

4WD model shown

Unit: mm

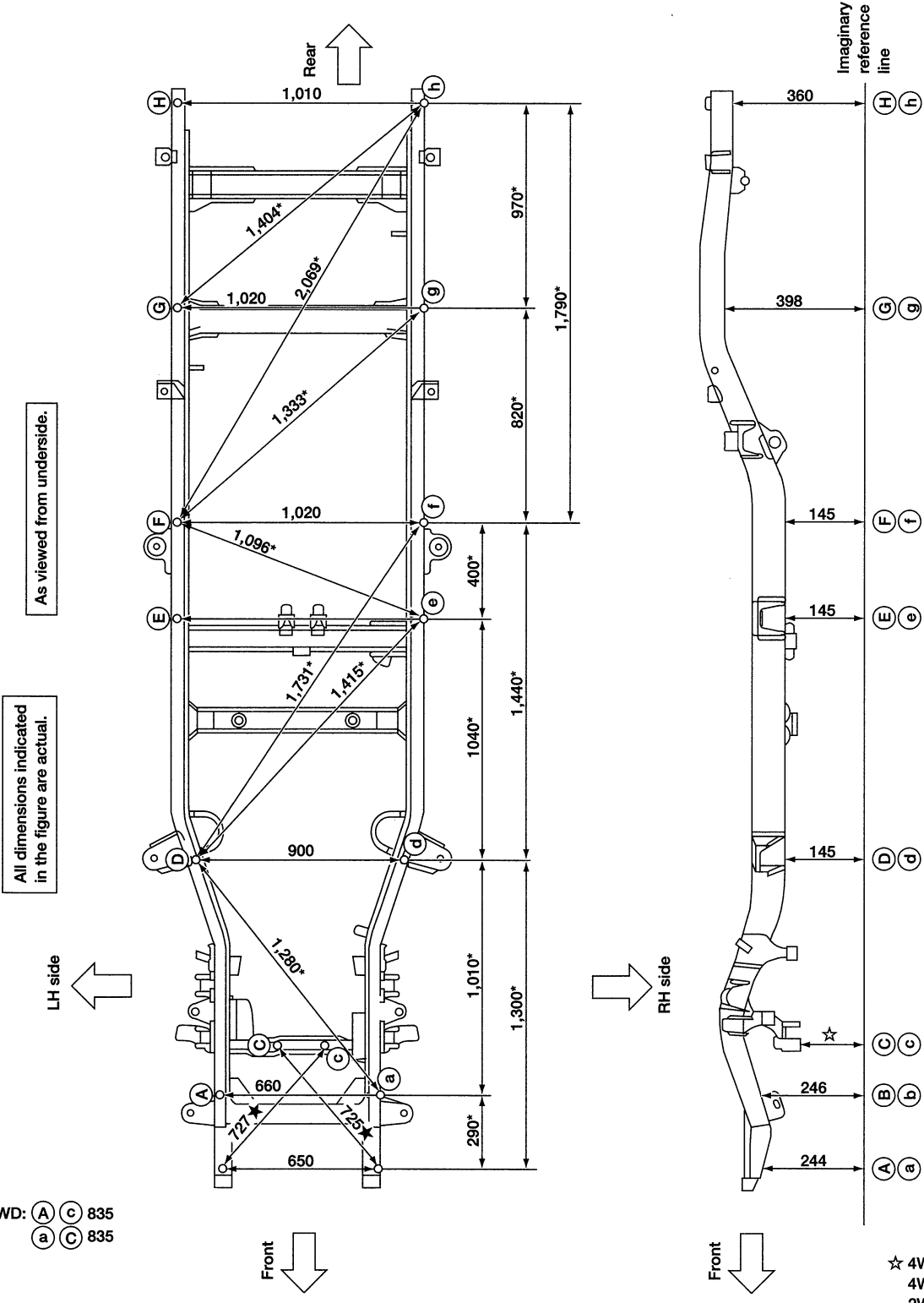

Underbody (Cont'd)

LONG WHEELBASE

MEASUREMENT POINTS

Unit: mm

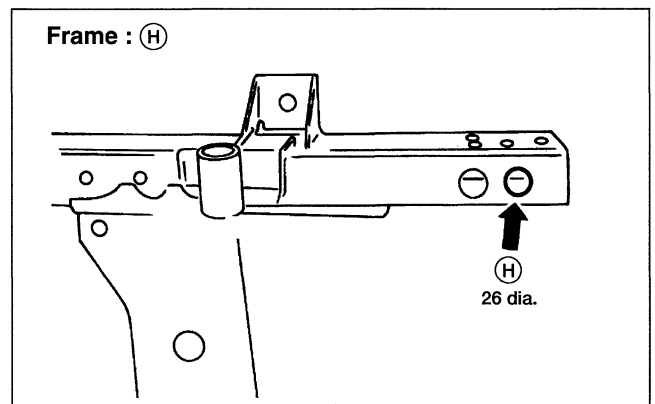
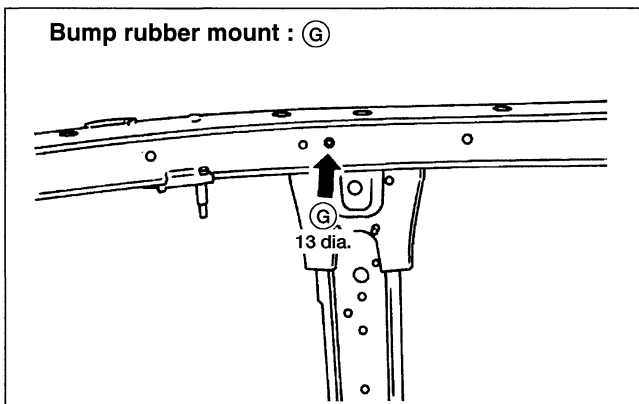
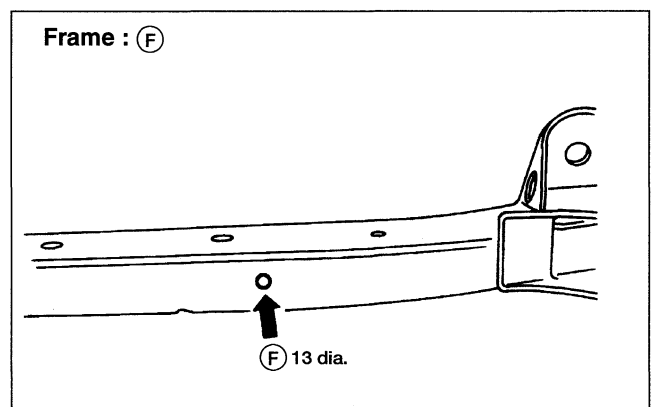
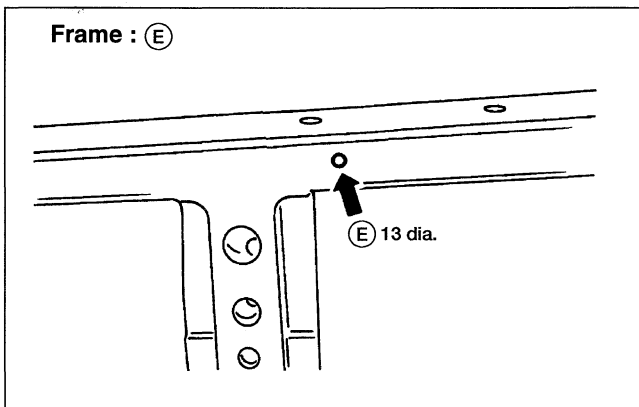
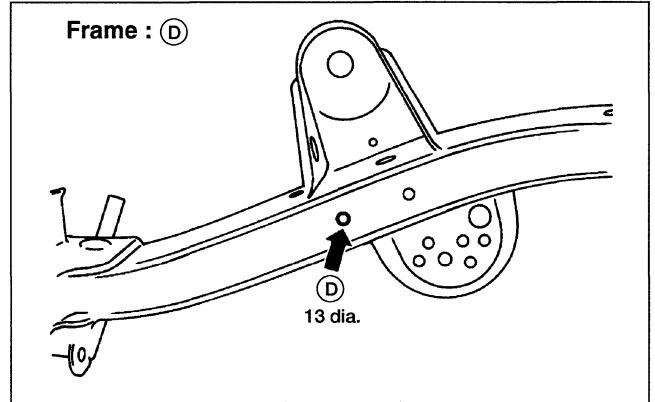
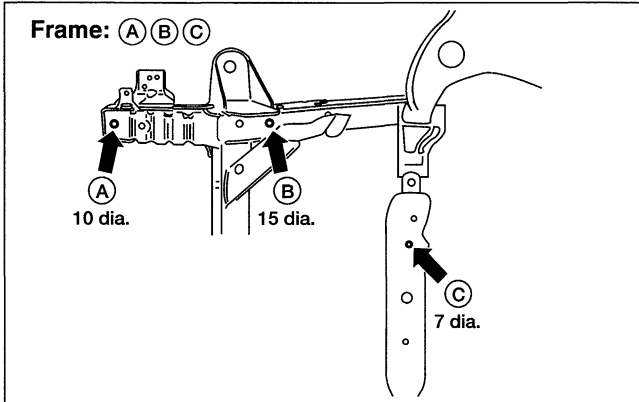

Coordinates:	(A), (a)	(B), (b)	(C), (c)	(D), (d)	(E), (e)	(F), (f)	(G), (g)	(H), (h)
X :	325	330	100	450	510	510	510	505
Y :	-700	-400	-129	600	1,040	1,640	2,860	3,830
Z :	244	246	4WD: RH 105 4WD: LH 97 2WD: 142	145	145	145	398	360

Unit: mm

Passenger Compartment

MEASUREMENT

Unit: mm

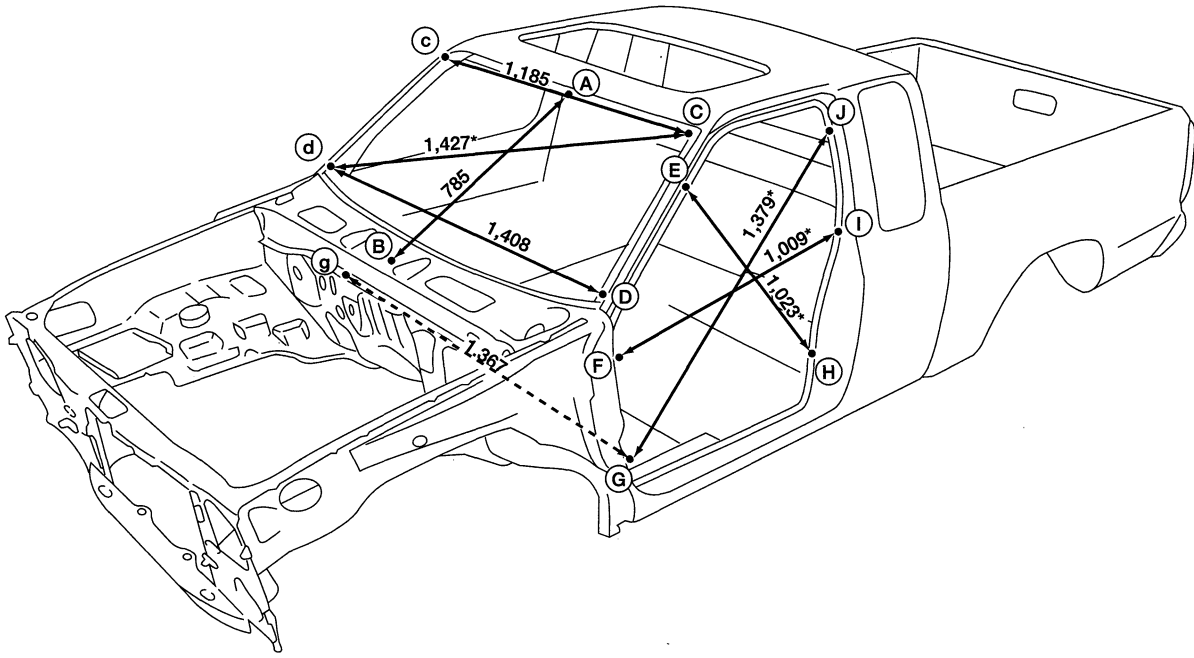

Point	Dimension	Point	Dimension	Point	Dimension	Point	Dimension	Point	Dimension
E - e	1,275	F - f	1,372	H - h	1,362	I - i	1,381	J - j	1,248

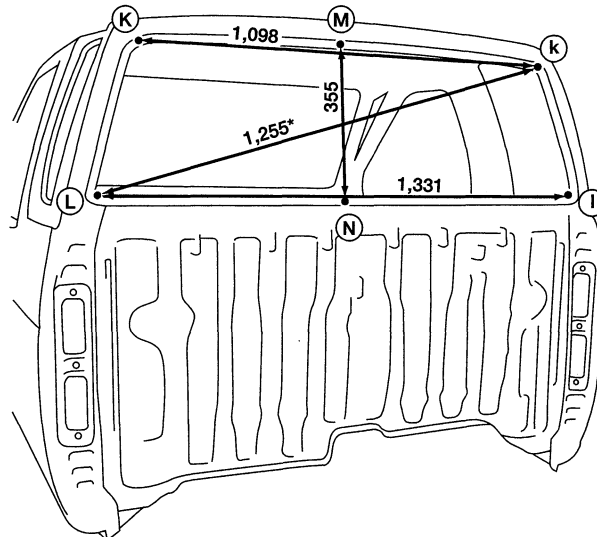

Passenger Compartment (Cont'd)

MEASUREMENT POINTS

Unit: mm

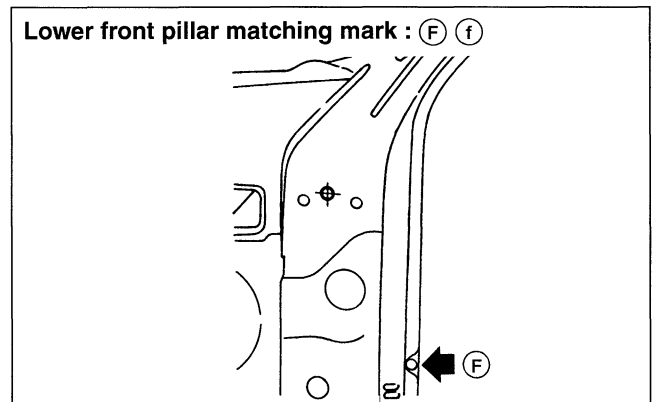
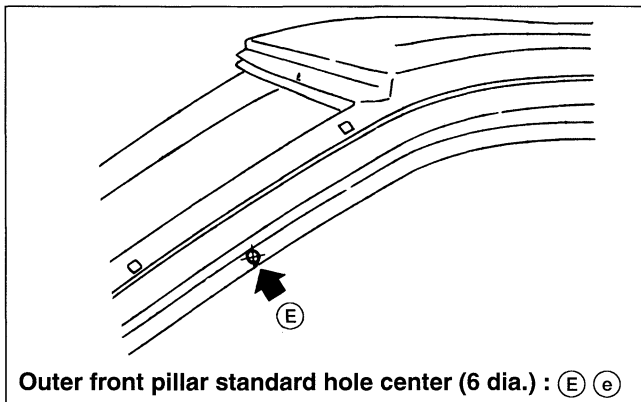
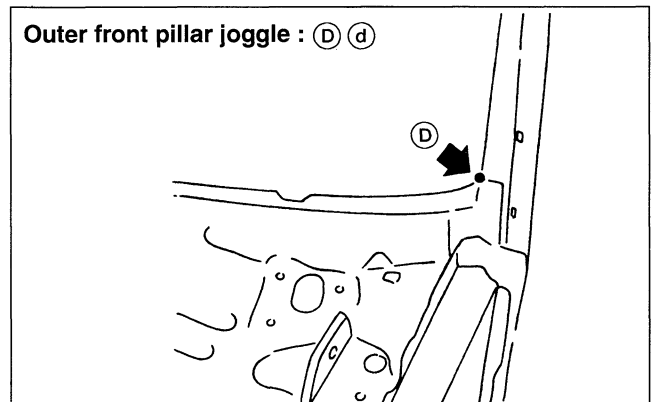
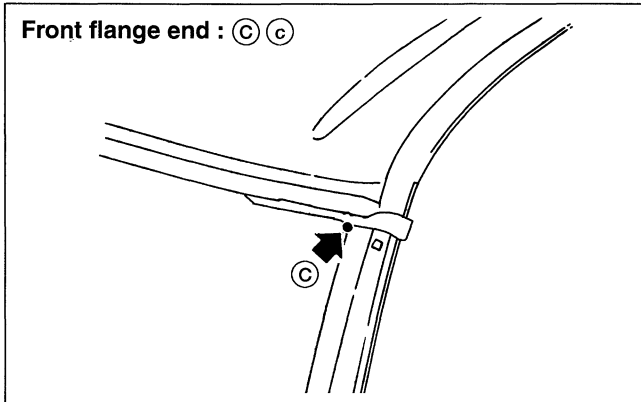
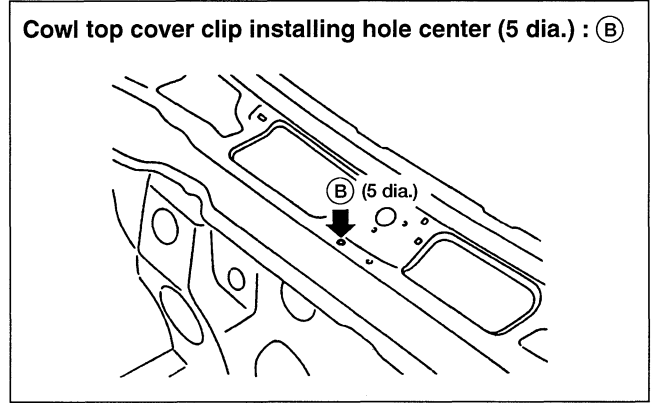
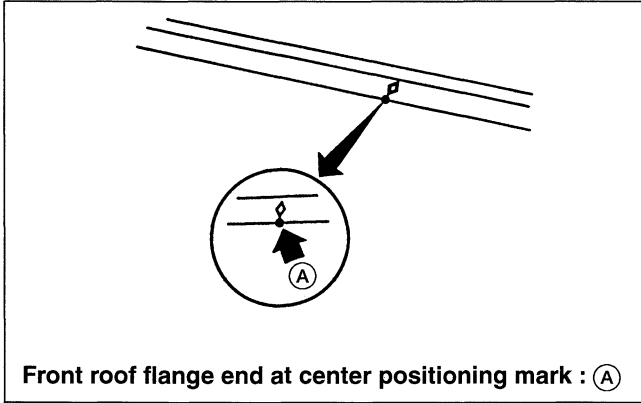

Passenger Compartment (Cont'd)

MEASUREMENT POINTS

Unit: mm

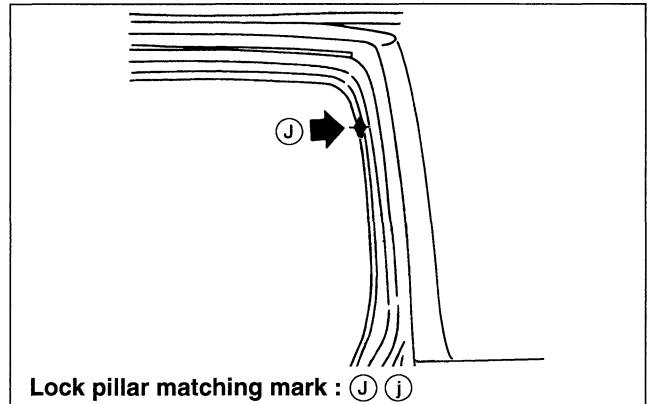
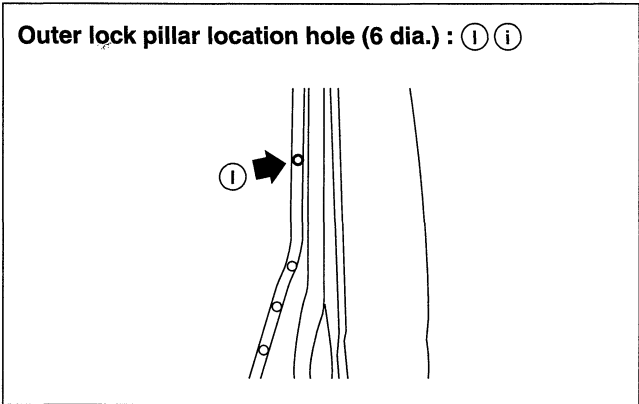
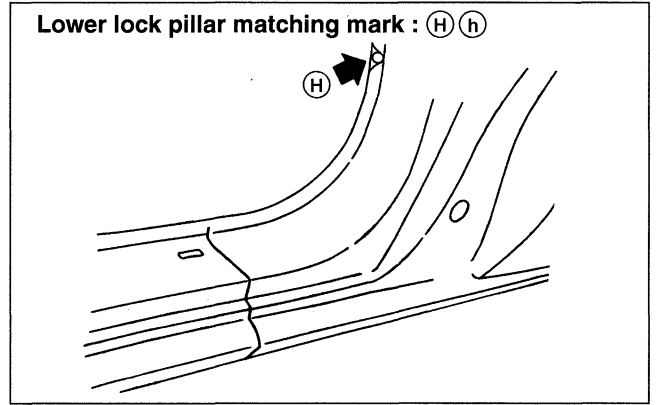
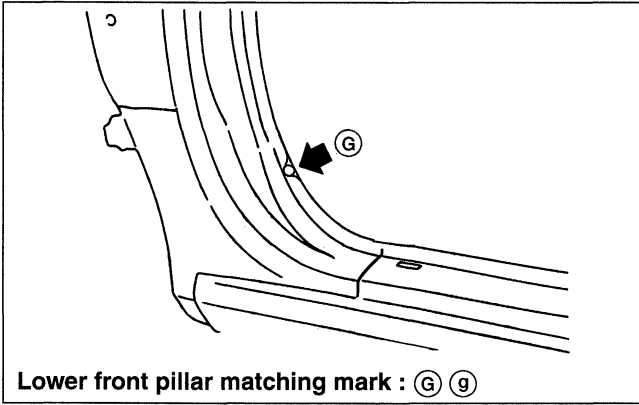

Passenger Compartment (Cont'd)

MEASUREMENT POINTS

Unit: mm

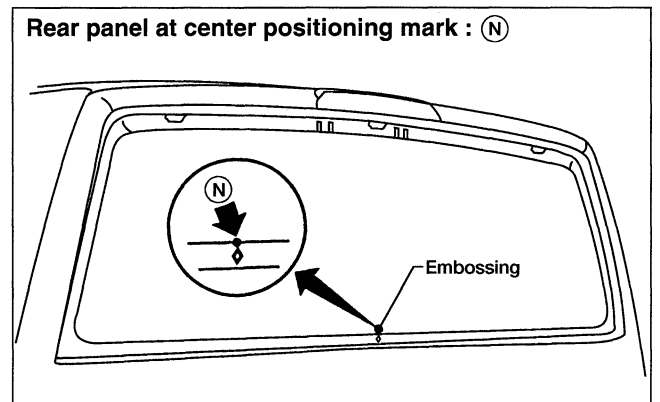
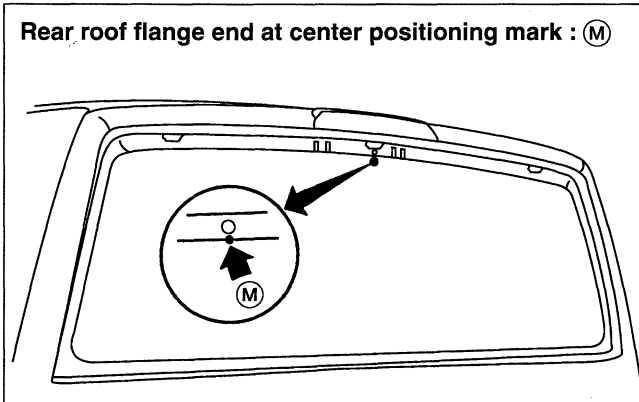
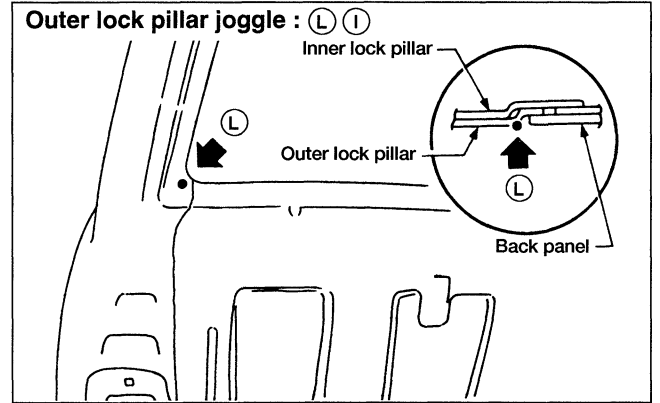
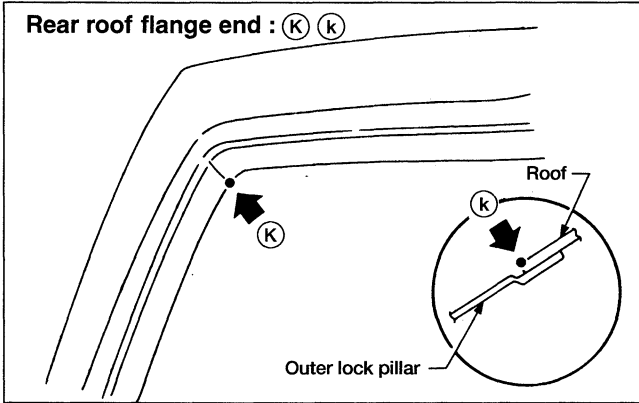

Handling Precautions for Plastics

Abbreviation	Material name	Heat resisting temperature °C (°F)	Resistance to gasoline and solvents	Other cautions
PET	Polyethylene terephthalate	180 (356)	Gasoline and most solvents are harmless.	
PVC	Polyvinyl chloride	80 (176)	Gasoline and most solvents are harmless if applied for a very short time (wipe up quickly).	Poison gas is emitted when burned.
PP	Polypropylene	90 (194)	Same as PVC. Also avoid battery acid.	Flammable
UP	Polyester thermoset	90 (194)	Same as PP.	Flammable
ABS	Acrylonitrile butadiene styrene resin	80 (176)	Avoid gasoline and solvents.	
PMMA	Polymethyl methacrylate	85 (185)	Avoid gasoline and solvents.	
AAS	Acrylonitrile acrylic rubber styrene	85 (185)	Avoid gasoline and solvents.	
PC	Polycarbonate	120 (248)	Avoid gasoline and solvents.	
PPC	Polypropylene composite	115 (239)	Gasoline and most solvents are harmless.	Flammable
PBT	Polybutylene terephthalate	140 (284)	Gasoline and most solvents are harmless.	
TPO	Polyolefinic	80 (176)	Avoid gasoline and solvents.	
PPE	Polyphenylene ether	85 (185)	Avoid gasoline and solvents.	
PS	Polystyrene	80 (176)	Avoid solvents.	Flammable
EPM	Ethylene propylene rubber	80 (176)	Same as PVC.	Flammable
PEI	Polyetherimide	200 (392)	Gasoline and most solvents are harmless.	
PA	Polyamide (Nylon)	140 (284)	Gasoline and most solvents are harmless.	Avoid immersing in water.
PBT + PC	Polybutylene terephthalate + Polycarbonate	120 (248)	Gasoline and most solvents are harmless.	Flammable

1. When repairing and painting a portion of the body adjacent to plastic parts, consider their characteristics (influence of heat and solvent) and remove them if necessary or take suitable measures to protect them.
2. Plastic parts should be repaired and painted using methods suiting the materials' characteristics.

Location of Plastic Parts

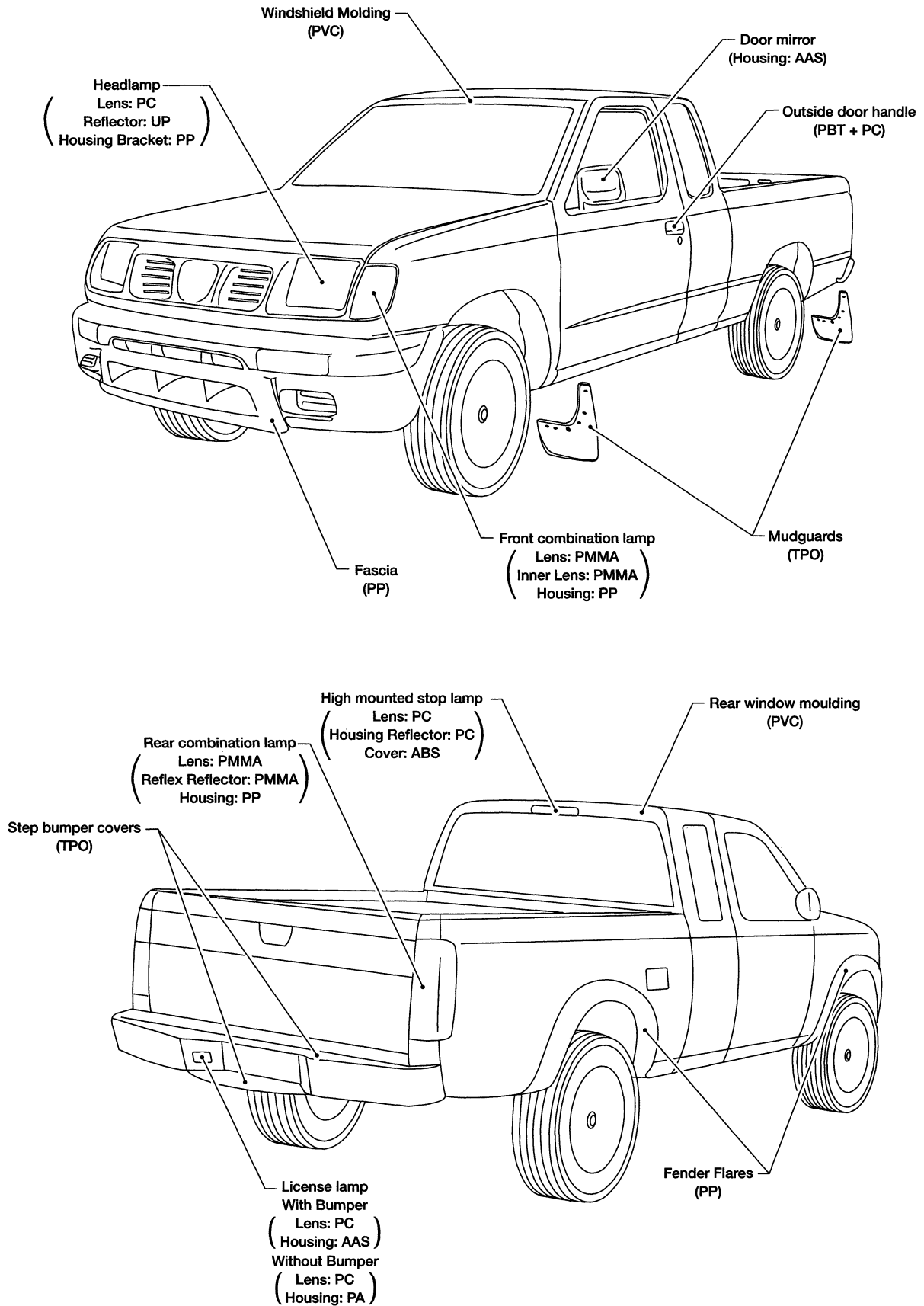



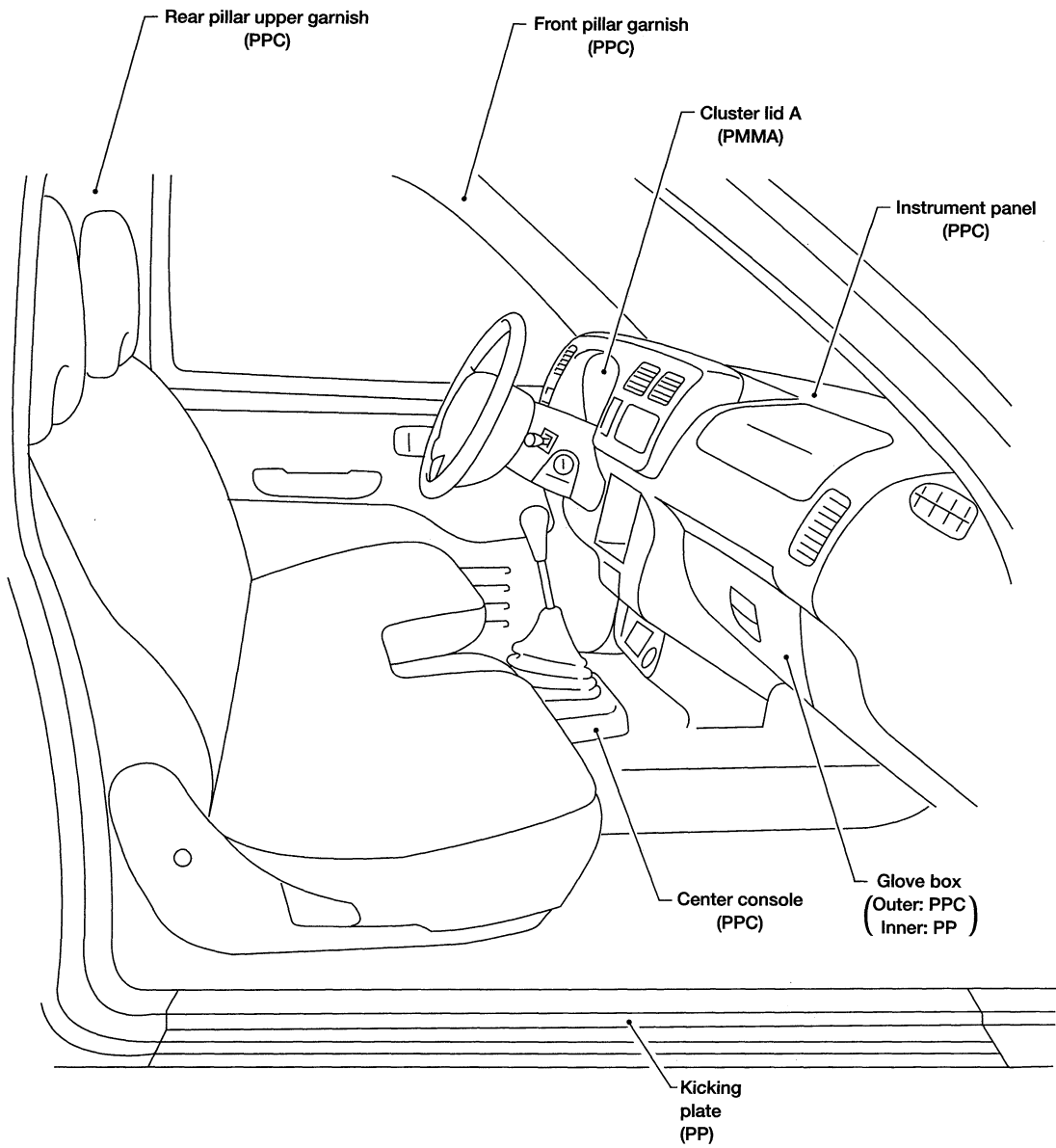





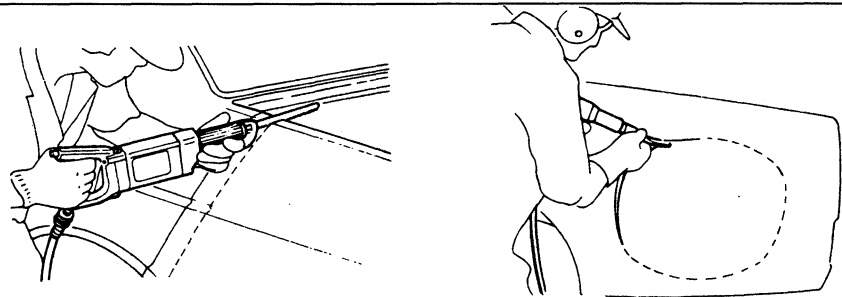
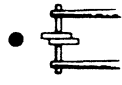
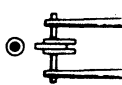

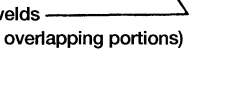
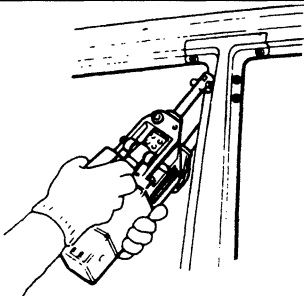

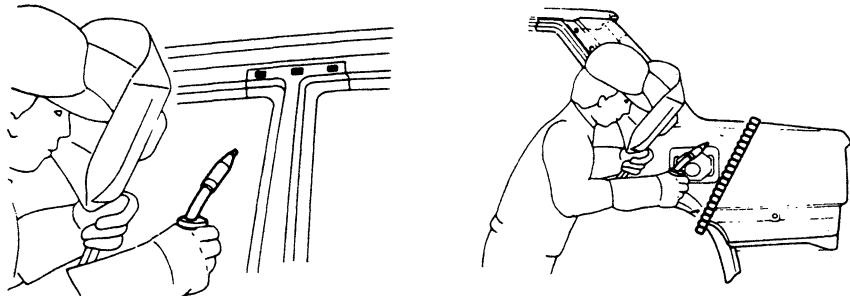

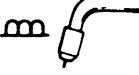
Location of Plastic Parts (Cont'd)

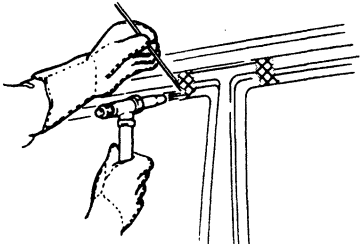

Description

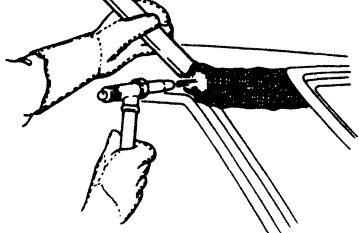
The identification for the cutting and the welding/brazing symbols used throughout this guide are given in the following pages.

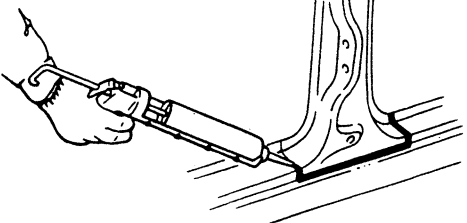
 <p>Saw cut or air chisel cut</p>		
<p>Spot weld</p> <p>● ● ● ●</p> <p>2-spot welds</p>  <p>○ ○ ○ ○</p> <p>3-spot welds</p> 	<p>2-spot welds (2-panel overlapping portions)</p>  <p>3-spot welds (3-panel overlapping portions)</p> 	
<p>M.I.G. plug weld</p>  		
<p>M.I.G. seam weld/ Point weld</p>  		
<p>Brazing</p>  		
<p>Soldering</p>  		
<p>Sealing</p> 		

Radiator Core Support

Service Joint

★ Indicates that there is an equivalent welding portion with the same dimensions on the opposite side.

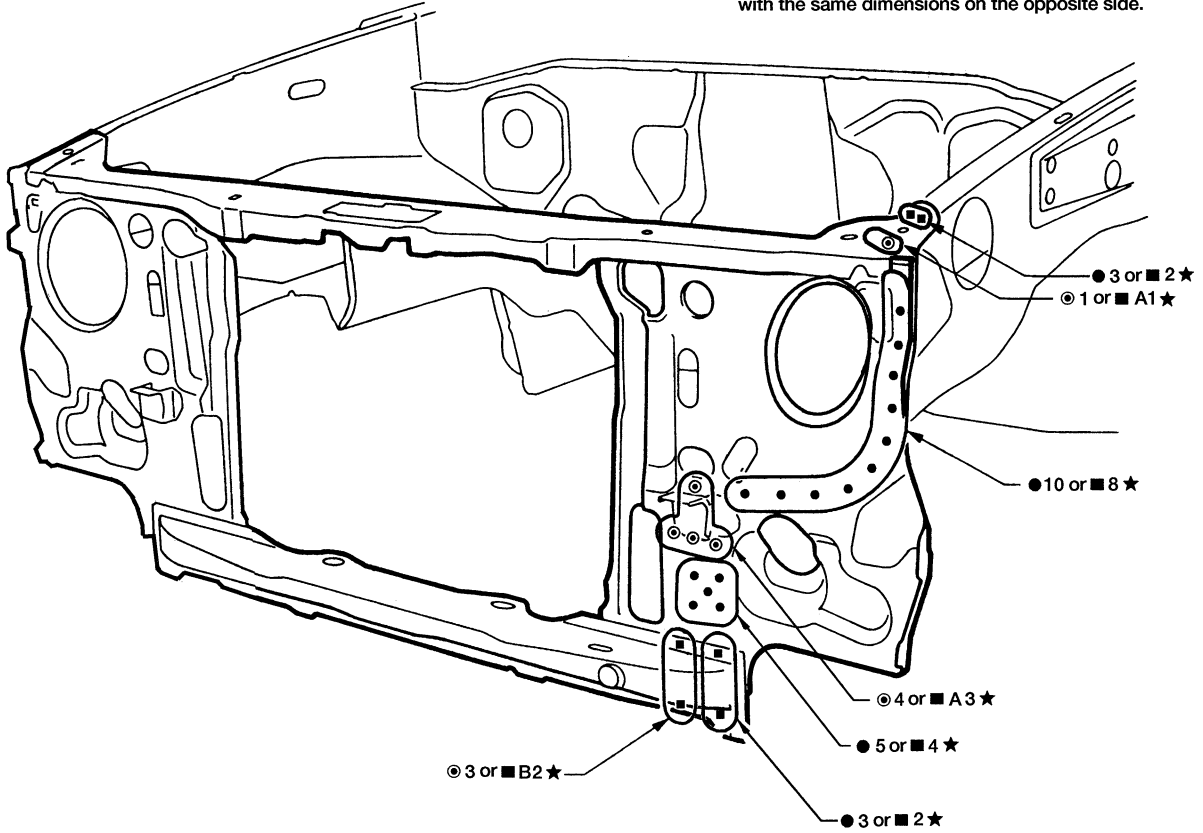

2-spot welds

3-spot welds

M.I.G plug weld

For 3 panels plug weld method

M.I.G seam weld/
Point weld

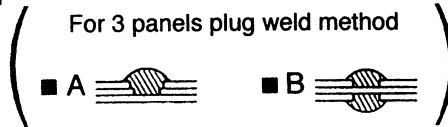
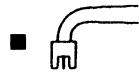
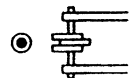
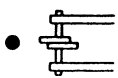

Radiator Core Support (Partial Replacement)

Service Joint

★ Indicates that there is an equivalent welding portion with the same dimensions on the opposite side.

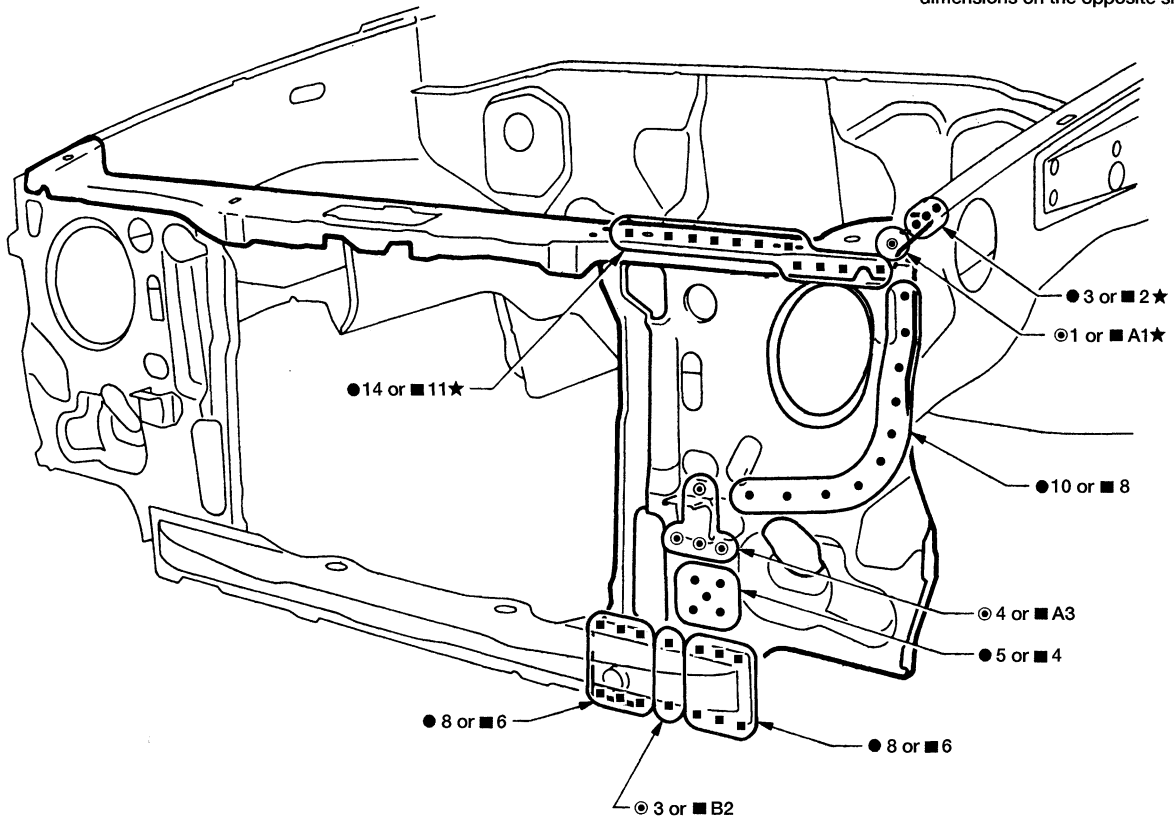

2-spot welds

3-spot welds

M.I.G plug weld

For 3 panels plug weld method

M.I.G seam weld/
Point weld



Hoodledge (Partial Replacement)

- Work after radiator core support has been removed.

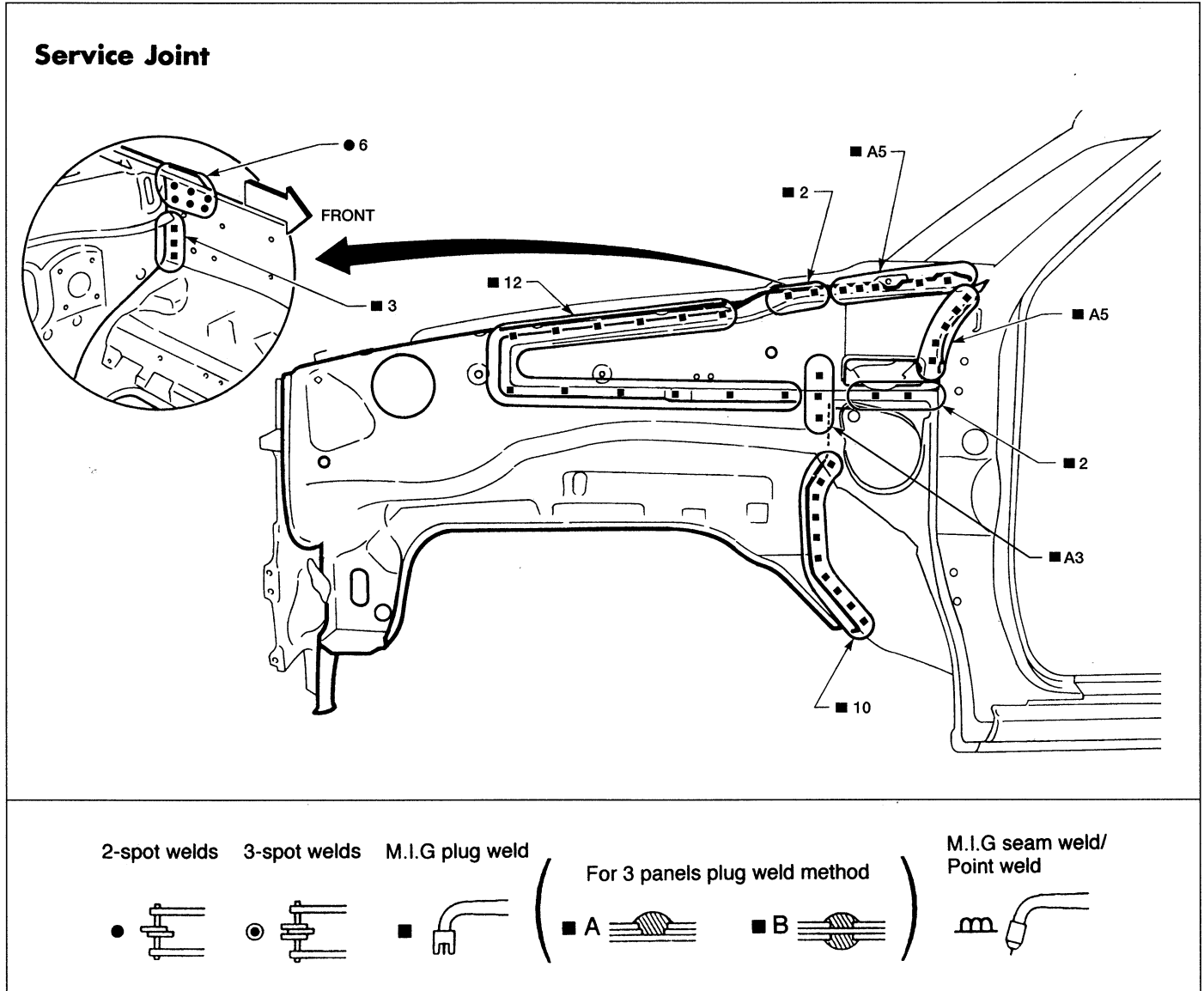

Front Pillar

- Work after hoodledge reinforcement has been removed.

Service Joint

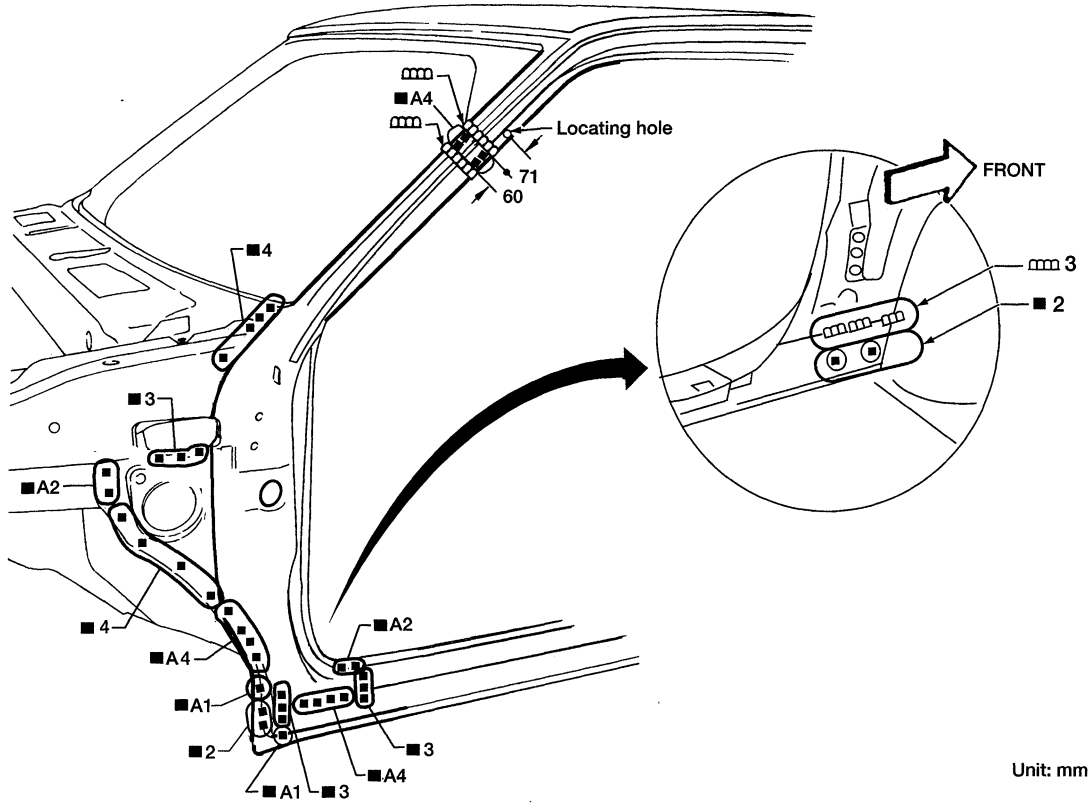

2-spot welds

3-spot welds

M.I.G plug weld

For 3 panels plug weld method

M.I.G seam weld/
Point weld



Lock Pillar

Standard Cab

Service Joint

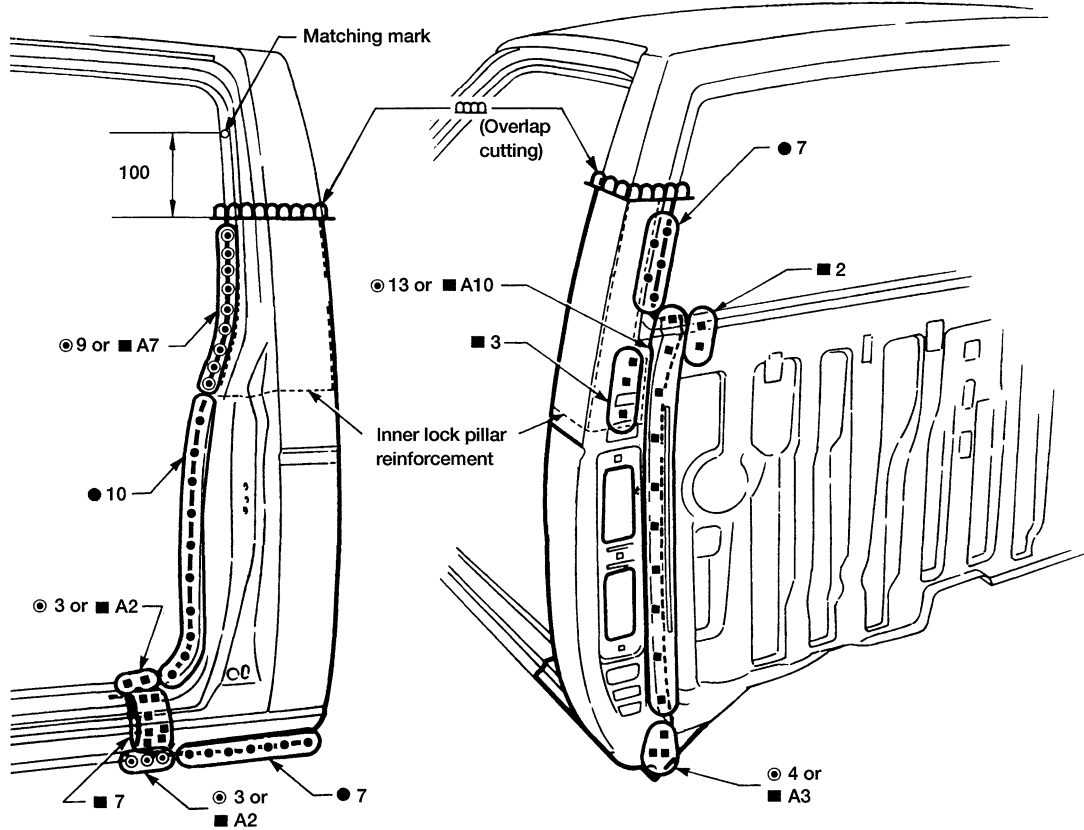

Unit: mm

2-spot welds

3-spot welds

M.I.G plug weld

For 3 panels plug weld method

M.I.G seam weld/
Point weld



Lock Pillar

King Cab

Service Joint

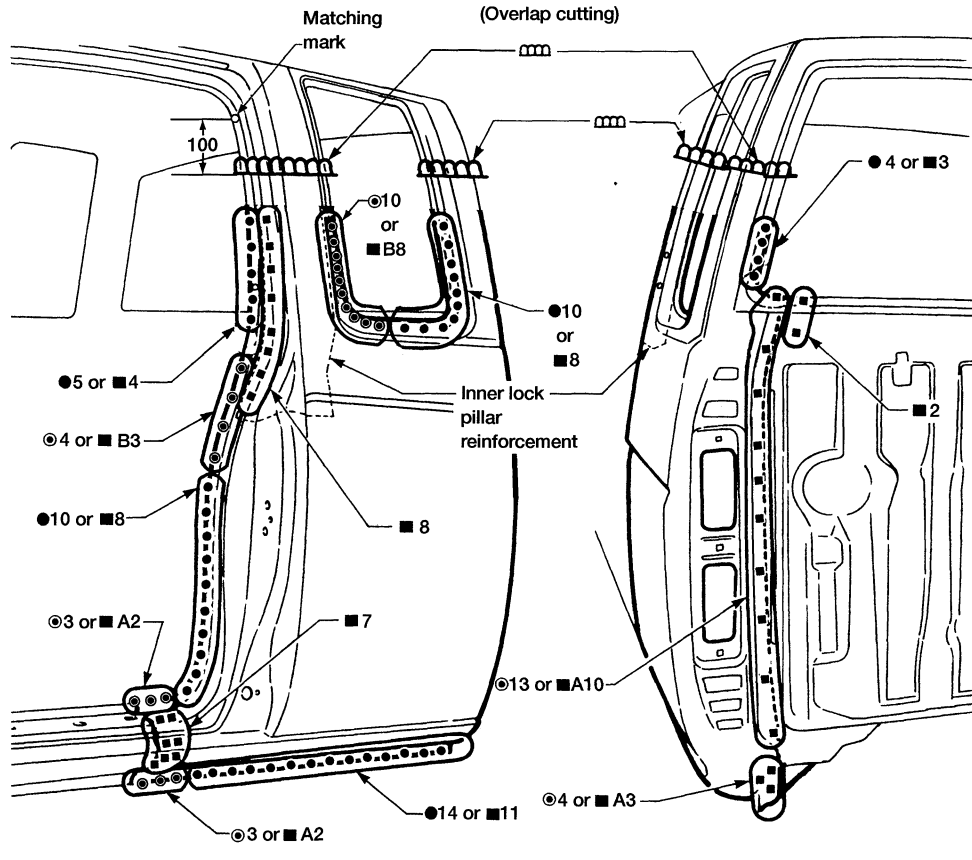

Unit: mm

2-spot welds

3-spot welds

M.I.G plug weld

For 3 panels plug weld method

M.I.G seam weld/
Point weld



Outer Sill

- Work after outer lock pillar has been removed.

Service Joint

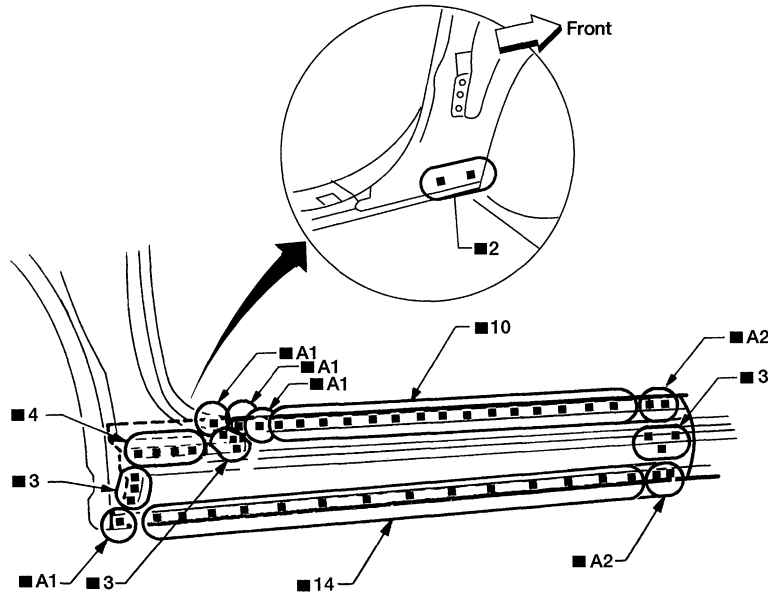

2-spot welds

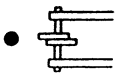

3-spot welds

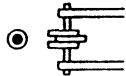

M.I.G plug weld



For 3 panels plug weld method



M.I.G seam weld/
Point weld



Back Panel

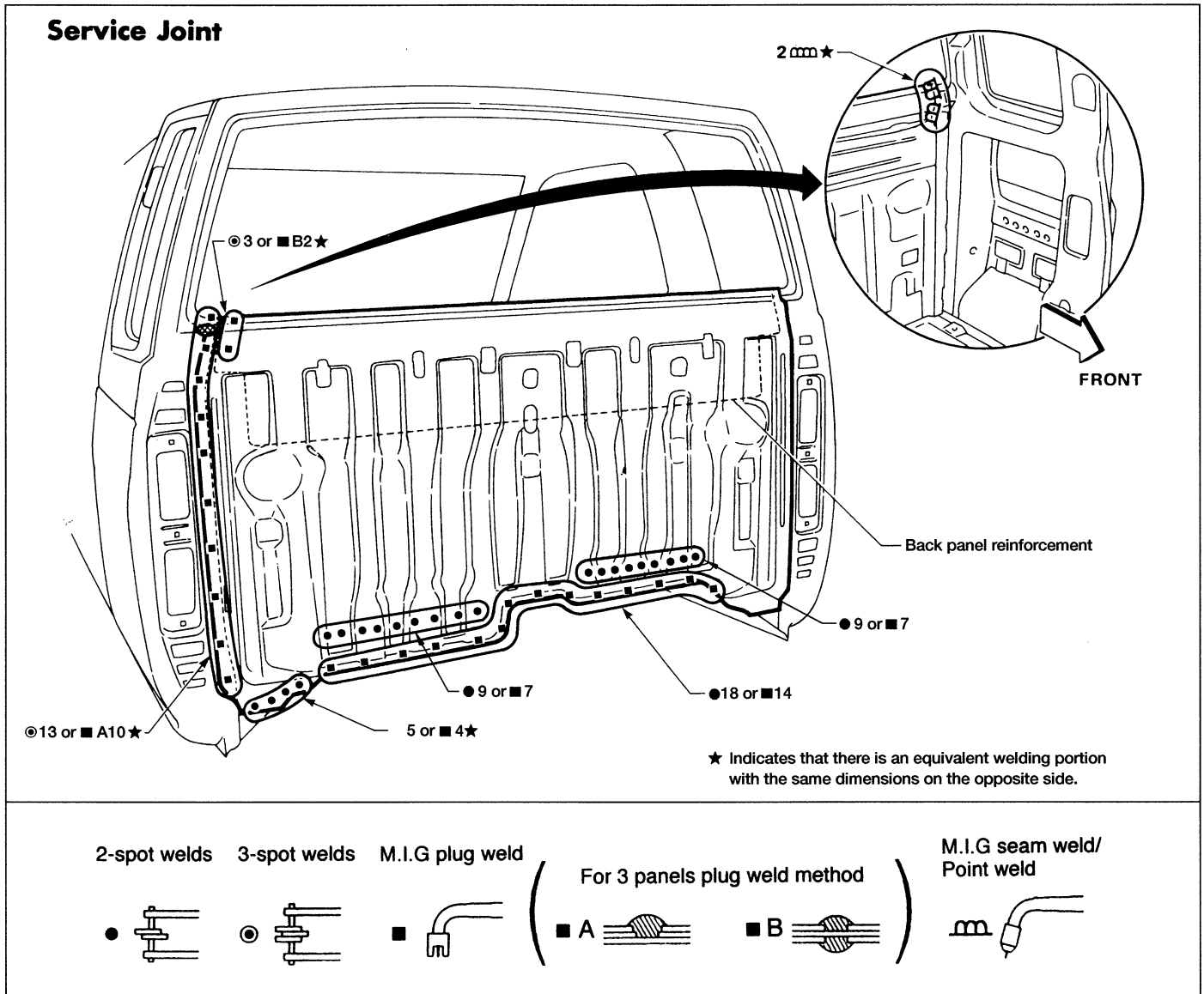

Notes

Notes

Notes

Notes

Notes

Notes

Notes