

# ENGINE CONTROL SYSTEM

## SECTION **EC**

### CONTENTS

<b>TROUBLE DIAGNOSIS — INDEX</b> .....	2	Introduction .....	44
Alphabetical & P No. Index for DTC .....	2	Two Trip Detection Logic.....	44
<b>PRECAUTIONS</b> .....	8	Emission-related Diagnostic Information.....	45
Supplemental Restraint System (SRS) "AIR BAG" .....	8	Malfunction Indicator Lamp (MIL).....	57
Precautions for On Board Diagnostic (OBD) System of Engine and A/T.....	8	OBD System Operation Chart.....	61
Engine Fuel & Emission Control System .....	9	CONSULT .....	66
Precautions .....	10	Generic Scan Tool (GST) .....	80
Wiring Diagrams and Trouble Diagnosis.....	11	<b>TROUBLE DIAGNOSIS — INTRODUCTION</b> .....	82
<b>PREPARATION</b> .....	12	Introduction .....	82
Special Service Tools .....	12	Work Flow.....	84
Commercial Service Tools.....	12	<b>TROUBLE DIAGNOSIS — BASIC INSPECTION</b> .....	86
<b>ENGINE AND EMISSION CONTROL OVERALL</b>		Basic Inspection.....	86
<b>SYSTEM</b> .....	14	<b>TROUBLE DIAGNOSIS — GENERAL</b>	
Engine Control Component Parts Location.....	14	<b>DESCRIPTION</b> .....	95
Circuit Diagram.....	16	DTC Inspection Priority Chart.....	95
System Diagram .....	17	Fail-safe Chart.....	96
Vacuum Hose Drawing .....	18	Symptom Matrix Chart.....	97
System Chart.....	19	CONSULT Reference Value in Data Monitor Mode .....	101
<b>ENGINE AND EMISSION BASIC CONTROL</b>		Major Sensor Reference Graph in Data Monitor Mode.....	103
<b>SYSTEM DESCRIPTION</b> .....	20	ECM Terminals and Reference Value .....	106
Multiport Fuel Injection (MFI) System .....	20	<b>TROUBLE DIAGNOSIS FOR INTERMITTENT</b>	
Distributor Ignition (DI) System .....	22	<b>INCIDENT</b> .....	115
Air Conditioning Cut Control.....	23	Description .....	115
Fuel Cut Control (at no load & high engine speed) .....	24	Diagnostic Procedure .....	115
Evaporative Emission System .....	24	<b>TROUBLE DIAGNOSIS FOR POWER SUPPLY</b> .....	116
Positive Crankcase Ventilation .....	30	Main Power Supply and Ground Circuit.....	116
<b>BASIC SERVICE PROCEDURE</b> .....	31	<b>DTC P0100 MASS AIR FLOW SENSOR (MAFS)</b> .....	121
Fuel Pressure Release.....	31	Component Description .....	121
Fuel Pressure Check.....	31	CONSULT Reference Value in Data Monitor Mode.....	121
Fuel Pressure Regulator Check .....	32	ECM Terminals and Reference Value .....	121
Injector .....	32	On Board Diagnostic Logic.....	121
Fast Idle Cam (FIC).....	33	DTC Confirmation Procedure .....	122
Idle Speed/Ignition Timing/Idle Mixture Ratio Adjustment.....	35	Overall Function Check .....	125
<b>ON BOARD DIAGNOSTIC SYSTEM</b>		Wiring Diagram.....	126
<b>DESCRIPTION</b> .....	44	Diagnostic Procedure .....	127
		Component Inspection.....	129

# CONTENTS (Cont'd)

<p><b>DTC P0105 ABSOLUTE PRESSURE SENSOR</b> .....130</p> <p>    Component Description .....130</p> <p>    On Board Diagnosis Logic.....130</p> <p>    DTC Confirmation Procedure .....130</p> <p>    Overall Function Check .....132</p> <p>    Wiring Diagram .....133</p> <p>    Diagnostic Procedure .....134</p> <p>    Component Inspection.....138</p> <p><b>DTC P0110 INTAKE AIR TEMPERATURE SENSOR</b> .....139</p> <p>    Component Description .....139</p> <p>    On Board Diagnosis Logic.....139</p> <p>    DTC Confirmation Procedure .....139</p> <p>    Wiring Diagram .....142</p> <p>    Diagnostic Procedure .....143</p> <p>    Component Inspection.....144</p> <p><b>DTC P0115 ENGINE COOLANT TEMPERATURE SENSOR (ECTS) (CIRCUIT)</b>.....145</p> <p>    Component Description .....145</p> <p>    On Board Diagnosis Logic.....145</p> <p>    DTC Confirmation Procedure .....146</p> <p>    Wiring Diagram .....147</p> <p>    Diagnostic Procedure .....148</p> <p>    Component Inspection.....149</p> <p><b>DTC P0120 THROTTLE POSITION SENSOR</b> .....150</p> <p>    Description .....150</p> <p>    CONSULT Reference Value in Data Monitor Mode .....150</p> <p>    ECM Terminals and Reference Value .....150</p> <p>    On Board Diagnosis Logic.....151</p> <p>    DTC Confirmation Procedure .....151</p> <p>    Wiring Diagram .....156</p> <p>    Diagnostic Procedure .....157</p> <p>    Component Inspection.....159</p> <p><b>DTC P0125 ENGINE COOLANT TEMPERATURE (ECT) SENSOR</b>.....161</p> <p>    Description .....161</p> <p>    On Board Diagnosis Logic.....161</p> <p>    DTC Confirmation Procedure .....161</p> <p>    Wiring Diagram .....163</p> <p>    Diagnostic Procedure .....164</p> <p>    Component Inspection.....165</p> <p><b>DTC P0130 (RIGHT BANK, -B1), P0150 (LEFT BANK, -B2) FRONT HEATED OXYGEN SENSOR (FRONT HO2S) (CIRCUIT)</b>.....166</p> <p>    Component Description .....166</p> <p>    CONSULT Reference Value in Data Monitor Mode .....166</p> <p>    ECM Terminals and Reference Value .....166</p> <p>    On Board Diagnosis Logic.....167</p> <p>    DTC Confirmation Procedure .....167</p> <p>    Overall Function Check .....168</p>	<p>    Wiring Diagram .....169</p> <p>    Diagnostic Procedure .....171</p> <p>    Component Inspection.....172</p> <p><b>DTC P0131 (RIGHT BANK, -B1), P0151 (LEFT BANK, -B2) FRONT HEATED OXYGEN SENSOR (FRONT HO2S) (LEAN SHIFT MONITORING)</b> .....174</p> <p>    Component Description .....174</p> <p>    CONSULT Reference Value in Data Monitor Mode .....174</p> <p>    ECM Terminals and Reference Value .....174</p> <p>    On Board Diagnosis Logic.....175</p> <p>    DTC Confirmation Procedure .....175</p> <p>    Overall Function Check .....176</p> <p>    Diagnostic Procedure .....177</p> <p>    Component Inspection.....178</p> <p><b>DTC P0132 (RIGHT BANK, -B1), P0152 (LEFT BANK, -B2) FRONT HEATED OXYGEN SENSOR (FRONT HO2S) (RICH SHIFT MONITORING)</b> .....180</p> <p>    Component Description .....180</p> <p>    CONSULT Reference Value in Data Monitor Mode .....180</p> <p>    ECM Terminals and Reference Value .....180</p> <p>    On Board Diagnosis Logic.....181</p> <p>    DTC Confirmation Procedure .....181</p> <p>    Overall Function Check .....182</p> <p>    Diagnostic Procedure .....183</p> <p>    Component Inspection.....184</p> <p><b>DTC P0133 (RIGHT BANK, -B1), P0153 (LEFT BANK, -B2) FRONT HEATED OXYGEN SENSOR (FRONT HO2S) (RESPONSE MONITORING)</b>.....186</p> <p>    Component Description .....186</p> <p>    CONSULT Reference Value in Data Monitor Mode .....186</p> <p>    ECM Terminals and Reference Value .....186</p> <p>    On Board Diagnosis Logic.....187</p> <p>    DTC Confirmation Procedure .....187</p> <p>    Overall Function Check .....188</p> <p>    Wiring Diagram .....189</p> <p>    Diagnostic Procedure .....191</p> <p>    Component Inspection.....193</p> <p><b>DTC P0134 (RIGHT BANK, -B1), P0154 (LEFT BANK, -B2) FRONT HEATED OXYGEN SENSOR (FRONT HO2S) (HIGH VOLTAGE)</b>.....194</p> <p>    Component Description .....194</p> <p>    CONSULT Reference Value in Data Monitor Mode .....194</p> <p>    ECM Terminals and Reference Value .....194</p> <p>    On Board Diagnosis Logic.....195</p> <p>    DTC Confirmation Procedure .....195</p> <p>    Wiring Diagram .....197</p> <p>    Diagnostic Procedure .....199</p> <p>    Component Inspection.....200</p>
---	---

# CONTENTS (Cont'd)

<b>DTC P0135 (RIGHT BANK, -B1), P0155 (LEFT BANK, -B2) FRONT HEATED OXYGEN SENSOR HEATER</b> .....202	<b>DTC P0140 (RIGHT BANK, -B1), P0160 (LEFT BANK, -B2) REAR HEATED OXYGEN SENSOR (REAR HO2S) (HIGH VOLTAGE)</b> .....234
Description.....202	Component Description.....234
CONSULT Reference Value in Data Monitor	CONSULT Reference Value in Data Monitor
Mode.....202	Mode.....234
ECM Terminals and Reference Value.....202	ECM Terminals and Reference Value.....234
On Board Diagnosis Logic.....202	On Board Diagnosis Logic.....234
DTC Confirmation Procedure.....203	DTC Confirmation Procedure.....235
Wiring Diagram.....204	Overall Function Check.....235
Diagnostic Procedure.....206	Wiring Diagram.....236
Component Inspection.....207	Diagnostic Procedure.....238
<b>DTC P0137 (RIGHT BANK, -B1), P0157 (LEFT BANK, -B2) REAR HEATED OXYGEN SENSOR (REAR HO2S) (MIN. VOLTAGE MONITORING)</b> .....208	Component Inspection.....239
Component Description.....208	<b>DTC P0141 (RIGHT BANK, -B1), P0161 (LEFT BANK, -B2) REAR HEATED OXYGEN SENSOR HEATER</b> .....241
CONSULT Reference Value in Data Monitor	Description.....241
Mode.....208	CONSULT Reference Value in Data Monitor
ECM Terminals and Reference Value.....208	Mode.....241
On Board Diagnosis Logic.....208	ECM Terminals and Reference Value.....241
DTC Confirmation Procedure.....209	On Board Diagnosis Logic.....241
Overall Function Check.....210	DTC Confirmation Procedure.....242
Wiring Diagram.....211	Wiring Diagram.....243
Diagnostic Procedure.....213	Diagnostic Procedure.....245
Component Inspection.....215	Component Inspection.....246
<b>DTC P0138 (RIGHT BANK, -B1), P0158 (LEFT BANK, -B2) REAR HEATED OXYGEN SENSOR (REAR HO2S) (MAX. VOLTAGE MONITORING)</b> .....217	<b>DTC P0171 (RIGHT BANK, -B1), P0174 (LEFT BANK, -B2) FUEL INJECTION SYSTEM FUNCTION (LEAN SIDE)</b> .....247
Component Description.....217	On Board Diagnosis Logic.....247
CONSULT Reference Value in Data Monitor	DTC Confirmation Procedure.....247
Mode.....217	Wiring Diagram.....249
ECM Terminals and Reference Value.....217	Diagnostic Procedure.....251
On Board Diagnosis Logic.....217	<b>DTC P0172 (RIGHT BANK, -B1), P0175 (LEFT BANK, -B2) FUEL INJECTION SYSTEM FUNCTION (RICH SIDE)</b> .....254
DTC Confirmation Procedure.....218	On Board Diagnosis Logic.....254
Overall Function Check.....219	DTC Confirmation Procedure.....254
Wiring Diagram.....220	Wiring Diagram.....256
Diagnostic Procedure.....222	Diagnostic Procedure.....258
Component Inspection.....224	<b>DTC P0180 TANK FUEL TEMPERATURE SENSOR</b> .....261
<b>DTC P0139 (RIGHT BANK, -B1), P0159 (LEFT BANK, -B2) REAR HEATED OXYGEN SENSOR (REAR HO2S) (RESPONSE MONITORING)</b> .....225	Component Description.....261
Component Description.....225	On Board Diagnosis Logic.....261
CONSULT Reference Value in Data Monitor	DTC Confirmation Procedure.....261
Mode.....225	Wiring Diagram.....263
ECM Terminals and Reference Value.....225	Diagnostic Procedure.....264
On Board Diagnosis Logic.....225	Component Inspection.....265
DTC Confirmation Procedure.....226	<b>DTC P0300 - P0306 NO. 6 - 1 CYLINDER MISFIRE, MULTIPLE CYLINDER MISFIRE</b> .....266
Overall Function Check.....227	On Board Diagnosis Logic.....266
Wiring Diagram.....228	DTC Confirmation Procedure.....266
Diagnostic Procedure.....230	Diagnostic Procedure.....267
Component Inspection.....232	

# CONTENTS (Cont'd)

Component Inspection.....	270	DTC Confirmation Procedure .....	304
<b>DTC P0325 KNOCK SENSOR (KS)</b> .....	271	Diagnostic Procedure .....	305
Component Description .....	271	<b>DTC P0443 EVAPORATIVE EMISSION (EVAP)</b>	
ECM Terminals and Reference Value .....	271	<b>CANISTER PURGE VOLUME CONTROL</b>	
On Board Diagnosis Logic.....	271	<b>SOLENOID VALVE (CIRCUIT)</b> .....	310
DTC Confirmation Procedure .....	271	Description.....	310
Wiring Diagram.....	273	CONSULT Reference Value in Data Monitor	
Diagnostic Procedure .....	274	Mode.....	310
Component Inspection.....	275	ECM Terminals and Reference Value .....	311
<b>DTC P0335 CRANKSHAFT POSITION SENSOR</b>		On Board Diagnosis Logic.....	311
<b>(CKPS) (OBD)</b> .....	276	DTC Confirmation Procedure .....	311
Component Description .....	276	Wiring Diagram.....	313
ECM Terminals and Reference Value .....	276	Diagnostic Procedure .....	314
On Board Diagnosis Logic.....	276	Component Inspection.....	315
DTC Confirmation Procedure .....	277	<b>DTC P0446 EVAPORATIVE EMISSION (EVAP)</b>	
Wiring Diagram.....	278	<b>CANISTER VENT CONTROL VALVE (CIRCUIT)</b> .....	316
Diagnostic Procedure .....	279	Component Description .....	316
Component Inspection.....	280	CONSULT Reference Value in Data Monitor	
<b>DTC P0340 CAMSHAFT POSITION SENSOR</b>		Mode.....	316
<b>(CMP)</b> .....	281	ECM Terminals and Reference Value .....	316
Component Description .....	281	On Board Diagnosis Logic.....	316
ECM Terminals and Reference Value .....	281	DTC Confirmation Procedure .....	316
On Board Diagnosis Logic.....	282	Wiring Diagram.....	318
DTC Confirmation Procedure .....	282	Diagnostic Procedure .....	319
Wiring Diagram.....	284	Component Inspection.....	320
Diagnostic Procedure .....	285	<b>DTC P0450 EVAPORATIVE EMISSION (EVAP)</b>	
Component Inspection.....	286	<b>CONTROL SYSTEM PRESSURE SENSOR</b> .....	322
<b>DTC P0400 EGR FUNCTION (CLOSE)</b> .....	288	Component Description .....	322
Description .....	288	CONSULT Reference Value in Data Monitor	
On Board Diagnosis Logic.....	289	Mode.....	322
DTC Confirmation Procedure .....	290	ECM Terminals and Reference Value .....	322
Overall Function Check .....	291	On Board Diagnosis Logic.....	323
Wiring Diagram.....	292	DTC Confirmation Procedure .....	323
Diagnostic Procedure .....	293	Wiring Diagram.....	325
Component Inspection.....	295	Diagnostic Procedure .....	326
<b>DTC P0402 EGRC-BPT VALVE FUNCTION</b> .....	296	Component Inspection.....	328
Description.....	296	<b>DTC P0500 VEHICLE SPEED SENSOR (VSS)</b> .....	330
On Board Diagnosis Logic.....	296	Component Description .....	330
DTC Confirmation Procedure .....	297	ECM Terminals and Reference Value .....	330
Overall Function Check .....	298	On Board Diagnosis Logic.....	330
Diagnostic Procedure .....	298	DTC Confirmation Procedure .....	330
Component Inspection.....	299	Overall Function Check .....	331
<b>DTC P0420 (RIGHT BANK, -B1), P0430 (LEFT</b>		Wiring Diagram.....	333
<b>BANK, -B2) THREE WAY CATALYST FUNCTION</b> .....	300	Diagnostic Procedure .....	334
On Board Diagnosis Logic.....	300	<b>DTC P0505 IDLE AIR CONTROL VALVE (IACV)</b>	
DTC Confirmation Procedure .....	300	<b>— AUXILIARY AIR CONTROL (AAC) VALVE</b> .....	335
Overall Function Check .....	301	Description .....	335
Diagnostic Procedure .....	301	CONSULT Reference Value in Data Monitor	
<b>DTC P0440 EVAPORATIVE EMISSION (EVAP)</b>		Mode.....	336
<b>CONTROL SYSTEM (SMALL LEAK) (NEGATIVE</b>		ECM Terminals and Reference Value .....	336
<b>PRESSURE)</b> .....	303	On Board Diagnosis Logic.....	336
On Board Diagnosis Logic.....	303	DTC Confirmation Procedure .....	336

# CONTENTS (Cont'd)

Wiring Diagram.....	339	Diagnostic Procedure.....	369
Diagnostic Procedure.....	340	Component Inspection.....	371
Component Inspection.....	341	<b>DTC P1336 CRANKSHAFT POSITION SENSOR</b>	
<b>DTC P0510 CLOSED THROTTLE POSITION</b>		<b>(CKPS) (OBD) (COG).....</b>	<b>372</b>
<b>SWITCH.....</b>	<b>342</b>	Component Description.....	372
Component Description.....	342	ECM Terminals and Reference Value.....	372
CONSULT Reference Value in Data Monitor		On Board Diagnosis Logic.....	372
Mode.....	342	DTC Confirmation Procedure.....	373
ECM Terminals and Reference Value.....	342	Wiring Diagram.....	374
On Board Diagnosis Logic.....	342	Diagnostic Procedure.....	375
DTC Confirmation Procedure.....	343	Component Inspection.....	376
Overall Function Check.....	343	<b>DTC P1400 EGRC-SOLENOID VALVE.....</b>	<b>377</b>
Wiring Diagram.....	344	Component Description.....	377
Diagnostic Procedure.....	345	CONSULT Reference Value in Data Monitor	
Component Inspection.....	346	Mode.....	377
<b>DTC P0600 A/T CONTROL.....</b>	<b>348</b>	ECM Terminals and Reference Value.....	377
System Description.....	348	On Board Diagnosis Logic.....	377
ECM Terminals and Reference Value.....	348	DTC Confirmation Procedure.....	377
On Board Diagnosis Logic.....	348	Wiring Diagram.....	379
DTC Confirmation Procedure.....	348	Diagnostic Procedure.....	380
Overall Function Check.....	349	Component Inspection.....	380
Wiring Diagram.....	350	<b>DTC P1401 EGR TEMPERATURE SENSOR.....</b>	<b>382</b>
Diagnostic Procedure.....	351	Component Description.....	382
<b>DTC P0605 ECM.....</b>	<b>352</b>	On Board Diagnosis Logic.....	382
Component Description.....	352	DTC Confirmation Procedure.....	383
On Board Diagnosis Logic.....	352	Overall Function Check.....	385
DTC Confirmation Procedure.....	352	Wiring Diagram.....	386
Diagnostic Procedure.....	353	Diagnostic Procedure.....	387
<b>DTC P1105 MANIFOLD ABSOLUTE PRESSURE</b>		Component Inspection.....	388
<b>(MAP)/BAROMETRIC PRESSURE (BARO)</b>		<b>DTC P1402 EGR FUNCTION (OPEN).....</b>	<b>389</b>
<b>SWITCH SOLENOID VALVE.....</b>	<b>354</b>	Description.....	389
Description.....	354	On Board Diagnosis Logic.....	390
CONSULT Reference Value in Data Monitor		DTC Confirmation Procedure.....	390
Mode.....	354	Wiring Diagram.....	392
ECM Terminals and Reference Value.....	355	Diagnostic Procedure.....	393
On Board Diagnosis Logic.....	355	Component Inspection.....	394
DTC Confirmation Procedure.....	355	<b>DTC P1440 EVAPORATIVE EMISSION (EVAP)</b>	
Wiring Diagram.....	358	<b>CONTROL SYSTEM (SMALL LEAK) (POSITIVE</b>	
Diagnostic Procedure.....	359	<b>PRESSURE).....</b>	<b>395</b>
Component Inspection.....	363	On Board Diagnosis Logic.....	395
<b>DTC P1148 (RIGHT BANK, -B1), P1168 (LEFT</b>		DTC Confirmation Procedure.....	396
<b>BANK, -B2) CLOSED LOOP CONTROL.....</b>	<b>364</b>	Diagnostic Procedure.....	397
On Board Diagnosis Logic.....	364	<b>DTC P1444 EVAPORATIVE EMISSION (EVAP)</b>	
DTC Confirmation Procedure.....	364	<b>CANISTER PURGE VOLUME CONTROL</b>	
Overall Function Check.....	365	<b>SOLENOID VALVE.....</b>	<b>402</b>
Diagnostic Procedure.....	365	Description.....	402
<b>DTC P1320 IGNITION SIGNAL.....</b>	<b>366</b>	CONSULT Reference Value in Data Monitor	
Component Description.....	366	Mode.....	402
ECM Terminals and Reference Value.....	366	ECM Terminals and Reference Value.....	403
On Board Diagnosis Logic.....	367	On Board Diagnosis Logic.....	403
DTC Confirmation Procedure.....	367	DTC Confirmation Procedure.....	404
Wiring Diagram.....	368	Wiring Diagram.....	405

GI  
MA  
EM  
LC  
EC  
FE  
CL  
MT  
AT  
TF  
PD  
FA  
RA  
BR  
ST  
RS  
BT  
HA  
EL  
IDX

# CONTENTS (Cont'd)

Diagnostic Procedure .....	406	Overall Function Check .....	434
Component Inspection .....	408	Wiring Diagram .....	435
<b>DTC P1446 EVAPORATIVE EMISSION (EVAP)</b>		Diagnostic Procedure .....	436
<b>CANISTER VENT CONTROL VALVE (CLOSE)</b> .....	409	Component Inspection.....	438
Component Description .....	409	<b>DTC P1605 A/T DIAGNOSIS COMMUNICATION</b>	
CONSULT Reference Value in Data Monitor		<b>LINE</b> .....	439
Mode .....	409	Component Description .....	439
ECM Terminals and Reference Value .....	409	ECM Terminals and Reference Value .....	439
On Board Diagnosis Logic.....	409	On Board Diagnosis Logic.....	439
DTC Confirmation Procedure .....	410	DTC Confirmation Procedure .....	439
Wiring Diagram .....	411	Wiring Diagram .....	440
Diagnostic Procedure .....	412	Diagnostic Procedure .....	441
Component Inspection.....	413	<b>DTC P1706 PARK/NEUTRAL POSITION (PNP)</b>	
<b>DTC P1447 EVAPORATIVE EMISSION (EVAP)</b>		<b>SWITCH</b> .....	442
<b>CONTROL SYSTEM PURGE FLOW</b>		Component Description .....	442
<b>MONITORING</b> .....	414	CONSULT Reference Value in Data Monitor	
System Description.....	414	Mode .....	442
On Board Diagnosis Logic.....	414	ECM Terminals and Reference Value .....	442
DTC Confirmation Procedure .....	415	On Board Diagnosis Logic.....	442
Overall Function Check .....	415	DTC Confirmation Procedure .....	442
Diagnostic Procedure .....	417	Overall Function Check .....	444
<b>DTC P1448 EVAPORATIVE EMISSION (EVAP)</b>		Wiring Diagram .....	445
<b>CANISTER VENT CONTROL VALVE (OPEN)</b> .....	420	Diagnostic Procedure .....	446
Component Description .....	420	<b>TROUBLE DIAGNOSIS FOR OVERHEAT</b>	
CONSULT Reference Value in Data Monitor		<b>(COOLING SYSTEM)</b> .....	450
Mode .....	420	System Description.....	450
ECM Terminals and Reference Value .....	420	CONSULT Reference Value in Data Monitor	
On Board Diagnosis Logic.....	420	Mode .....	450
DTC Confirmation Procedure .....	421	ECM Terminals and Reference Value .....	450
Overall Function Check .....	422	On Board Diagnosis Logic.....	450
Wiring Diagram .....	423	Overall Function Check .....	451
Diagnostic Procedure .....	424	Wiring Diagram .....	453
Component Inspection.....	425	Diagnostic Procedure .....	454
<b>DTC P1490 VACUUM CUT VALVE BYPASS</b>		Main 12 Causes of Overheating.....	457
<b>VALVE (CIRCUIT)</b> .....	427	Component Inspection.....	458
Description .....	427	<b>INJECTOR</b> .....	459
CONSULT Reference Value in Data Monitor		Component Description .....	459
Mode .....	427	CONSULT Reference Value in Data Monitor	
ECM Terminals and Reference Value .....	427	Mode .....	459
On Board Diagnosis Logic.....	428	ECM Terminals and Reference Value .....	459
DTC Confirmation Procedure .....	428	Wiring Diagram .....	460
Wiring Diagram .....	429	Diagnostic Procedure .....	461
Diagnostic Procedure .....	430	Component Inspection.....	462
Component Inspection.....	431	<b>START SIGNAL</b> .....	463
<b>DTC P1491 VACUUM CUT VALVE BYPASS</b>		CONSULT Reference Value in Data Monitor	
<b>VALVE</b> .....	432	Mode .....	463
Description .....	432	ECM Terminals and Reference Value .....	463
CONSULT Reference Value in Data Monitor		Wiring Diagram .....	464
Mode .....	432	Diagnostic Procedure .....	465
ECM Terminals and Reference Value .....	432	<b>FUEL PUMP</b> .....	467
On Board Diagnosis Logic.....	433	System Description.....	467
DTC Confirmation Procedure .....	433	Component Description .....	467

# CONTENTS (Cont'd)

CONSULT Reference Value in Data Monitor Mode.....467	MIL & DATA LINK CONNECTORS .....482	GI
ECM Terminals and Reference Value .....467	Wiring Diagram .....482	MA
Wiring Diagram .....468	<b>SERVICE DATA AND SPECIFICATIONS (SDS) .....483</b>	EM
Diagnostic Procedure .....469	Fuel Pressure Regulator.....483	LC
Component Inspection.....470	Idle Speed and Ignition Timing.....483	EC
<b>POWER STEERING OIL PRESSURE SWITCH.....472</b>	Ignition Coil.....483	FE
Component Description .....472	Mass Air Flow Sensor.....483	CL
CONSULT Reference Value in Data Monitor	Engine Coolant Temperature Sensor .....483	MT
Mode.....472	EGR Temperature Sensor .....483	AT
ECM Terminals and Reference Value .....472	Front Heated Oxygen Sensor Heater.....483	TF
Wiring Diagram.....473	Fuel Pump .....484	PD
Diagnostic Procedure .....474	IACV-AAC Valve .....484	FA
Component Inspection.....476	Injector .....484	RA
<b>IACV-FICD SOLENOID VALVE.....477</b>	Resistor.....484	BR
Component Description .....477	Throttle Position Sensor .....484	ST
ECM Terminals and Reference Value .....477	Calculated Load Value.....484	RS
Wiring Diagram .....478	Intake Air Temperature Sensor.....484	BT
Diagnostic Procedure .....479	Rear Heated Oxygen Sensor Heater .....484	HA
Component Inspection.....480	Crankshaft Position Sensor (OBD).....484	EL
	Tank Fuel Temperature Sensor .....484	IDX

# TROUBLE DIAGNOSIS — INDEX

Alphabetical & P No. Index for DTC

## Alphabetical & P No. Index for DTC

### ALPHABETICAL INDEX FOR DTC

NEEC0001

NEEC0001S01

Items (CONSULT screen terms)	DTC*6		Reference page
	ECM*1	CONSULT GST*2	
Unable to access ECM	—	—	EC-96
ABSL PRES SEN/CIRC	0803	P0105	EC-130
AIR TEMP SEN/CIRC	0401	P0110	EC-139
A/T 1ST GR FNCTN	1103	P0731	AT-106
A/T 2ND GR FNCTN	1104	P0732	AT-112
A/T 3RD GR FNCTN	1105	P0733	AT-118
A/T 4TH GR FNCTN	1106	P0734	AT-124
A/T COMM LINE	—	P0600	EC-348
A/T DIAG COMM LINE	0804	P1605	EC-439
A/T TCC S/V FNCTN	1107	P0744	AT-138
ATF TEMP SEN/CIRC	1206	P0710	AT-92
CAM POS SEN/CIRC	0101	P0340	EC-281
CLOSED LOOP-B1	0307	P1148	EC-364
CLOSED LOOP-B2	0308	P1168	EC-364
CLOSED TP SW/CIRC	0203	P0510	EC-342
COOLANT T SEN/CIRC*3	0103	P0115	EC-145
*COOLANT T SEN/CIRC	0908	P0125	EC-161
CPS/CIRC (OBD) COG	0905	P1336	EC-372
CPS/CIRCUIT (OBD)	0802	P0335	EC-276
CYL 1 MISFIRE	0608	P0301	EC-266
CYL 2 MISFIRE	0607	P0302	EC-266
CYL 3 MISFIRE	0606	P0303	EC-266
CYL 4 MISFIRE	0605	P0304	EC-266
CYL 5 MISFIRE	0604	P0305	EC-266
CYL 6 MISFIRE	0603	P0306	EC-266
ECM	0301	P0605	EC-352
EGR SYSTEM	0302	P0400	EC-288
EGR SYSTEM	0514	P1402	EC-389
EGR TEMP SEN/CIRC	0305	P1401	EC-382
EGRC SOLENOID/V	1005	P1400	EC-377
EGRC-BPT VALVE	0306	P0402	EC-296
ENGINE SPEED SIG	1207	P0725	AT-102
EVAP PURG FLOW/MON	0111	P1447	EC-414
EVAP SYS PRES SEN	0704	P0450	EC-322



# TROUBLE DIAGNOSIS — INDEX

*Alphabetical & P No. Index for DTC (Cont'd)*

Items (CONSULT screen terms)	DTC*6		Reference page
	ECM*1	CONSULT GST*2	
EVAP SMALL LEAK	0705	P0440	EC-303
EVAP SMALL LEAK	0213	P1440	EC-395
FR O2 SE HEATER-B1	0901	P0135	EC-202
FR O2 SE HEATER-B2	1001	P0155	EC-202
FRONT O2 SENSOR-B1	0503	P0130	EC-166
FRONT O2 SENSOR-B1	0415	P0131	EC-174
FRONT O2 SENSOR-B1	0414	P0132	EC-180
FRONT O2 SENSOR-B1	0413	P0133	EC-186
FRONT O2 SENSOR-B1	0509	P0134	EC-194
FRONT O2 SENSOR-B2	0303	P0150	EC-166
FRONT O2 SENSOR-B2	0411	P0151	EC-174
FRONT O2 SENSOR-B2	0410	P0152	EC-180
FRONT O2 SENSOR-B2	0409	P0153	EC-186
FRONT O2 SENSOR-B2	0412	P0154	EC-194
FUEL SYS LEAN/BK1	0115	P0171	EC-247
FUEL SYS LEAN/BK2	0210	P0174	EC-247
FUEL SYS RICH/BK1	0114	P0172	EC-254
FUEL SYS RICH/BK2	0209	P0175	EC-254
FUEL TEMP SEN/CIRC	0402	P0180	EC-261
IACV/AAC VLV/CIRC	0205	P0505	EC-335
IGN SIGNAL-PRIMARY	0201	P1320	EC-366
KNOCK SENSOR	0304	P0325	EC-271
L/PRES SOL/CIRC	1205	P0745	AT-146
MAP/BARO SW SOL/CIR	1302	P1105	EC-354
MAF SEN/CIRCUIT*3	0102	P0100	EC-121
MULTI CYL MISFIRE	0701	P0300	EC-266
<b>NO SELF DIAGNOSTIC FAILURE INDICATED</b>	<b>0505</b>	<b>P0000</b>	—
NO SELF DIAGNOSTIC FAILURE INDICATED	Flashing*5	No DTC	EC-58
OVER HEAT	0208	—	EC-450
O/R CLTCH S/CIRC	1203	P1760	AT-168
P-N POS SW/CIRCUIT	1003	P0705	EC-442
PNP SW/CIRC	1101	P0705	AT-87
PURG VOLUME CONT/V	1008	P0443	EC-310
PURG VOLUME CONT/V	0214	P1444	EC-402
REAR O2 SENSOR-B1	0511	P0137	EC-208
REAR O2 SENSOR-B1	0510	P0138	EC-217

GI  
MA  
EM  
LC  
**EC**  
FE  
CL  
MT  
AT  
TF  
PD  
FA  
RA  
BR  
ST  
RS  
BT  
HA  
EL  
IDX

## TROUBLE DIAGNOSIS — INDEX

Alphabetical & P No. Index for DTC (Cont'd)

Items (CONSULT screen terms)	DTC*6		Reference page
	ECM*1	CONSULT GST*2	
REAR O2 SENSOR-B1	0707	P0139	EC-225
REAR O2 SENSOR-B1	0512	P0140	EC-234
REAR O2 SENSOR-B2	0314	P0157	EC-208
REAR O2 SENSOR-B2	0313	P0158	EC-217
REAR O2 SENSOR-B2	0708	P0159	EC-225
REAR O2 SENSOR-B2	0315	P0160	EC-234
RR O2 SE HEATER-B1	0902	P0141	EC-241
RR O2 SE HEATER-B2	1002	P0161	EC-241
SFT SOL A/CIRC*3	1108	P0750	AT-151
SFT SOL B/CIRC*3	1201	P0755	AT-156
TCC SOLENOID/CIRC	1204	P0740	AT-133
TP SEN/CIRC A/T*3	1206	P1705	AT-161
TRTL POS SEN/CIRC*3	0403	P0120	EC-150
TW CATALYST SYS-B1	0702	P0420	EC-300
TW CATALYST SYS-B2	0703	P0430	EC-300
VC CUT/V BYPASS/V	0311	P1491	EC-432
VC/V BYPASS/V	0801	P1490	EC-427
VEH SPEED SEN/CIRC*4	0104	P0500	EC-330
VEH SPD SEN/CIRC*4	1102	P0720	AT-97
VENT CONTROL VALVE	0903	P0446	EC-316
VENT CONTROL VALVE	0215	P1446	EC-409
VENT CONTROL VALVE	0309	P1448	EC-420

\*1: In Diagnostic Test Mode II (Self-diagnostic results). These numbers are controlled by NISSAN.

\*2: These numbers are prescribed by SAE J2012.

\*3: When the fail-safe operation occurs, the MIL illuminates.

\*4: The MIL illuminates when both the "Revolution sensor signal" and the "Vehicle speed sensor signal" meet the fail-safe condition at the same time.

\*5: While engine is running.

\*6: 1st trip DTC No. is the same as DTC No.

**NOTE:**

Regarding D22 models, "-B1" and "BK1" indicate right bank and "-B2" and "BK2" indicate left bank.

# TROUBLE DIAGNOSIS — INDEX

Alphabetical & P No. Index for DTC (Cont'd)

## P NO. INDEX FOR DTC

#NEEC0001S02

DTC*6		Items (CONSULT screen terms)	Reference page
CONSULT GST*2	ECM*1		
—	—	Unable to access ECM	EC-96
No DTC	Flashing*5	NO SELF DIAGNOSTIC FAILURE INDICATED	EC-58
<b>P0000</b>	<b>0505</b>	<b>NO SELF DIAGNOSTIC FAILURE INDICATED</b>	—
P0100	0102	MAF SEN/CIRCUIT*3	EC-121
P0105	0803	ABSL PRES SEN/CIRC	EC-130
P0110	0401	AIR TEMP SEN/CIRC	EC-139
P0115	0103	COOLANT T SEN/CIRC*3	EC-145
P0120	0403	THRTL POS SEN/CIRC*3	EC-150
P0125	0908	*COOLANT T SEN/CIRC	EC-161
P0130	0503	FRONT O2 SENSOR-B1	EC-166
P0131	0415	FRONT O2 SENSOR-B1	EC-174
P0132	0414	FRONT O2 SENSOR-B1	EC-180
P0133	0413	FRONT O2 SENSOR-B1	EC-186
P0134	0509	FRONT O2 SENSOR-B1	EC-194
P0135	0901	FR O2 SE HEATER-B1	EC-202
P0137	0511	REAR O2 SENSOR-B1	EC-208
P0138	0510	REAR O2 SENSOR-B1	EC-217
P0139	0707	REAR O2 SENSOR-B1	EC-225
P0140	0512	REAR O2 SENSOR-B1	EC-234
P0141	0902	RR O2 SE HEATER-B1	EC-241
P0150	0303	FRONT O2 SENSOR-B2	EC-166
P0151	0411	FRONT O2 SENSOR-B2	EC-174
P0152	0410	FRONT O2 SENSOR-B2	EC-180
P0153	0409	FRONT O2 SENSOR-B2	EC-186
P0154	0412	FRONT O2 SENSOR-B2	EC-194
P0155	1001	FR O2 SE HEATER-B2	EC-202
P0157	0314	REAR O2 SENSOR-B2	EC-208
P0158	0313	REAR O2 SENSOR-B2	EC-217
P0159	0708	REAR O2 SENSOR-B2	EC-225
P0160	0315	REAR O2 SENSOR-B2	EC-234
P0161	1002	RR O2 SE HEATER-B2	EC-241
P0171	0115	FUEL SYS LEAN/BK1	EC-247
P0172	0114	FUEL SYS RICH/BK1	EC-254
P0174	0210	FUEL SYS LEAN/BK2	EC-247
P0175	0209	FUEL SYS RICH/BK2	EC-254

GI  
MA  
EM  
LC  
**EC**  
FE  
CL  
MT  
AT  
TF  
PD  
FA  
RA  
BR  
ST  
RS  
BT  
HA  
EL  
IDX

## TROUBLE DIAGNOSIS — INDEX

Alphabetical & P No. Index for DTC (Cont'd)

DTC*6		Items (CONSULT screen terms)	Reference page
CONSULT GST*2	ECM*1		
P0180	0402	FUEL TEMP SEN/CIRC	EC-261
P0300	0701	MULTI CYL MISFIRE	EC-266
P0301	0608	CYL 1 MISFIRE	EC-266
P0302	0607	CYL 2 MISFIRE	EC-266
P0303	0606	CYL 3 MISFIRE	EC-266
P0304	0605	CYL 4 MISFIRE	EC-266
P0305	0604	CYL 5 MISFIRE	EC-266
P0306	0603	CYL 6 MISFIRE	EC-266
P0325	0304	KNOCK SENSOR	EC-271
P0335	0802	CPS/CIRCUIT (OBD)	EC-276
P0340	0101	CAM POS SEN/CIRC	EC-281
P0400	0302	EGR SYSTEM	EC-288
P0402	0306	EGRC-BPT VALVE	EC-296
P0420	0702	TW CATALYST SYS-B1	EC-300
P0430	0703	TW CATALYST SYS-B2	EC-300
P0440	0705	EVAP SMALL LEAK	EC-303
P0443	1008	PURG VOLUME CONT/V	EC-310
P0446	0903	VENT CONTROL VALVE	EC-316
P0450	0704	EVAP SYS PRES SEN	EC-322
P0500	0104	VEH SPEED SEN/CIRC*4	EC-330
P0505	0205	IACV/AAC VLV/CIRC	EC-335
P0510	0203	CLOSED TP SW/CIRC	EC-342
P0600	—	A/T COMM LINE	EC-348
P0605	0301	ECM	EC-352
P0705	1101	PNP SW/CIRC	AT-87
P0710	1208	ATF TEMP SEN/CIRC	AT-92
P0720	1102	VEH SPD SEN/CIRC A/T*4	AT-97
P0725	1207	ENGINE SPEED SIG	AT-102
P0731	1103	A/T 1ST GR FNCTN	AT-106
P0732	1104	A/T 2ND GR FNCTN	AT-112
P0733	1105	A/T 3RD GR FNCTN	AT-118
P0734	1106	A/T 4TH GR FNCTN	AT-124
P0740	1204	TCC SOLENOID/CIRC	AT-133
P0744	1107	A/T TCC S/V FNCTN	AT-138
P0745	1205	L/PRESS SOL/CIRC	AT-146
P0750	1108	SFT SOL A/CIRC*3	AT-151

# TROUBLE DIAGNOSIS — INDEX

*Alphabetical & P No. Index for DTC (Cont'd)*

DTC*6		Items (CONSULT screen terms)	Reference page
CONSULT GST*2	ECM*1		
P0755	1201	SFT SOL B/CIRC*3	AT-156
P1105	1302	MAP/BARO SW SOL/CIR	EC-354
P1148	0307	CLOSED LOOP-B1	EC-364
P1168	0308	CLOSED LOOP-B2	EC-364
P1320	0201	IGN SIGNAL-PRIMARY	EC-366
P1336	0905	CPS/CIRC (OBD) COG	EC-372
P1400	1005	EGRC SOLENOID/V	EC-377
P1401	0305	EGR TEMP SEN/CIRC	EC-382
P1402	0514	EGR SYSTEM	EC-389
P1440	0213	EVAP SMALL LEAK	EC-395
P1444	0214	PURG VOLUME CONT/V	EC-402
P1446	0215	VENT CONTROL VALVE	EC-409
P1447	0111	EVAP PURG FLOW/MON	EC-414
P1448	0309	VENT CONTROL VALVE	EC-420
P1490	0801	VC/V BYPASS/V	EC-427
P1491	0311	VC CUT/V BYPASS/V	EC-432
P1605	0804	A/T DIAG COMM LINE	EC-439
P1705	1206	TP SEN/CIRC A/T*3	AT-161
P1706	1003	P-N POS SW/CIRCUIT	EC-442
P1760	1203	O/R CLUTCH SOL/CIRC	AT-168
—	0208	OVER HEAT	EC-450

\*1: In Diagnostic Test Mode II (Self-diagnostic results). These numbers are controlled by NISSAN.

\*2: These numbers are prescribed by SAE J2012.

\*3: When the fail-safe operation occurs, the MIL illuminates.

\*4: The MIL illuminates when both the "Revolution sensor signal" and the "Vehicle speed sensor signal" meet the fail-safe condition at the same time.

\*5: While engine is running.

\*6: 1st trip DTC No. is the same as DTC No.

**NOTE:**

Regarding D22 models, "-B1" and "BK1" indicate right bank and "-B2" and "BK2" indicate left bank.

GI  
MA  
EM  
LC  
EC  
FE  
CL  
MT  
AT  
TF  
PD  
FA  
RA  
BR  
ST  
RS  
BT  
HA  
EL  
IDX

## PRECAUTIONS

Supplemental Restraint System (SRS) "AIR BAG"

### Supplemental Restraint System (SRS) "AIR BAG"

NEEC0002

The Supplemental Restraint System "AIR BAG", used along with a seat belt, helps to reduce the risk or severity of injury to the driver and front passenger in a frontal collision. The Supplemental Restraint System consists of air bag modules (located in the center of the steering wheel and in the instrument panel on the passenger side), a diagnosis sensor unit, a crash zone sensor, warning lamp, wiring harness and spiral cable.

The vehicle is equipped with a passenger air bag deactivation switch. Because no rear seat exists where a rear-facing child restraint can be placed, the switch is designed to turn off the passenger air bag so that a rear-facing child restraint can be used in the front passenger seat. The switch is located in the center of the instrument panel, near the ashtray. When the switch is turned to the ON position, the passenger air bag is enabled and could inflate in a frontal collision. When the switch is turned to the OFF position, the passenger air bag is disabled and will not inflate in a frontal collision. A passenger air bag OFF indicator on the instrument panel lights up when the passenger air bag is switched OFF. The driver air bag always remains enabled and is not affected by the passenger air bag deactivation switch. Information necessary to service the system safely is included in the **RS** section of this Service Manual.

#### WARNING:

- To avoid rendering the SRS inoperative, which could increase the risk of personal injury or death in the event of a collision which would result in air bag inflation, all maintenance should be performed by an authorized NISSAN dealer.
- Improper maintenance, including incorrect removal and installation of the SRS, can lead to personal injury caused by unintentional activation of the system.
- Do not use electrical test equipment on any circuit related to the SRS unless instructed to in this Service Manual. SRS wiring harnesses are covered with yellow insulation either just before the harness connectors or on the complete harness, for easy identification.
- The vehicle is equipped with a passenger air bag deactivation switch which can be operated by the customer. When the passenger air bag is switched OFF, the passenger air bag is disabled and will not inflate in a frontal collision. When the passenger air bag is switched ON, the passenger air bag is enabled and could inflate in a frontal collision. After SRS maintenance or repair, make sure the passenger air bag deactivation switch is in the same position (ON or OFF) as when the vehicle arrived for service.

### Precautions for On Board Diagnostic (OBD) System of Engine and AT

NEEC0003

The ECM has an on board diagnostic system. It will light up the malfunction indicator lamp (MIL) to warn the driver of a malfunction causing emission deterioration.

#### CAUTION:

- Be sure to turn the ignition switch OFF and disconnect the negative battery terminal before any repair or inspection work. The open/short circuit of related switches, sensors, solenoid valves, etc. will cause the MIL to light up.
- Be sure to connect and lock the connectors securely after work. A loose (unlocked) connector will cause the MIL to light up due to the open circuit. (Be sure the connector is free from water, grease, dirt, bent terminals, etc.)
- Certain systems and components, especially those related to OBD, may use a new style slide-locking type harness connector. For description and how to disconnect, refer to EL section, "Description", "HARNES CONNECTOR".
- Be sure to route and secure the harnesses properly after work. The interference of the harness with a bracket, etc. may cause the MIL to light up due to the short circuit.
- Be sure to connect rubber tubes properly after work. A misconnected or disconnected rubber tube may cause the MIL to light up due to the malfunction of the EGR system or fuel injection system, etc.
- Be sure to erase the unnecessary malfunction information (repairs completed) from the ECM and TCM (Transmission control module) before returning the vehicle to the customer.

# PRECAUTIONS

Engine Fuel & Emission Control System

## Engine Fuel & Emission Control System

NEEC0004

### ECM

- Do not disassemble ECM.
- Do not turn on board diagnostic test mode selector forcibly.
- If a battery terminal is disconnected, the memory will return to the ECM value.

The ECM will now start to self-control at its initial value. Engine operation can vary slightly when the terminal is disconnected. However, this is not an indication of a problem. Do not replace parts because of a slight variation.

### WIRELESS EQUIPMENT

- When installing CB ham radio or a mobile phone, be sure to observe the following as it may adversely affect electronic control systems depending on its installation location.
  - 1) Keep the antenna as far away as possible from the electronic control units.
  - 2) Keep the antenna feeder line more than 20 cm (7.9 in) away from the harness of electronic controls. Do not let them run parallel for a long distance.
  - 3) Adjust the antenna and feeder line so that the standing-wave ratio can be kept smaller.
  - 4) Be sure to ground the radio to vehicle body.

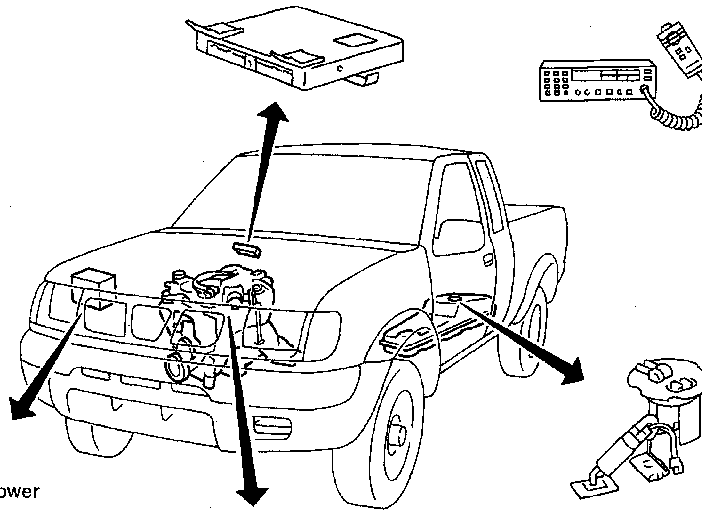

### BATTERY

- Always use a 12 volt battery as power source.
- Do not attempt to disconnect battery cables while engine is running.

### WHEN STARTING

- Do not depress accelerator pedal when starting.
- Immediately after starting, do not rev up engine unnecessarily.
- Do not rev up engine just prior to shutdown.

### ECM PARTS HANDLING

- Handle mass air flow sensor carefully to avoid damage.
- Do not disassemble mass air flow sensor.
- Do not clean mass air flow sensor with any type of detergent.
- Do not disassemble IACV-AAC valve.
- Even a slight leak in the air intake system can cause serious problems.
- Do not shock or jar the camshaft position sensor or crankshaft position sensor (OBD).



### FUEL PUMP

- Do not operate fuel pump when there is no fuel in lines.
- Tighten fuel hose clamps to the specified torque. (Refer to MA section.)

### ECM HARNESS HANDLING

- Securely connect ECM harness connectors. A poor connection can cause an extremely high (surge) voltage to develop in coil and condenser, thus resulting in damage to ICs.
- Keep ECM harness at least 10 cm (3.9 in.) away from adjacent harnesses to prevent an ECM system malfunction due to receiving external noise, degraded operation of ICs, etc.
- Keep ECM parts and harnesses dry.
- Before removing parts, turn off ignition switch and then disconnect battery ground cable.

SEF236V

GI  
MA  
EM  
LC  
EC  
FE  
CL  
MT  
AT  
TF  
PD  
FA  
RA  
BR  
ST  
RS  
BT  
HA  
EL  
IDX

# PRECAUTIONS

## Precautions

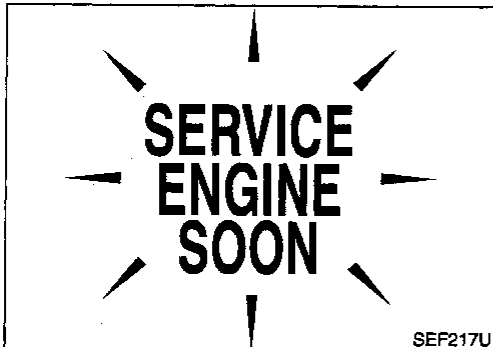
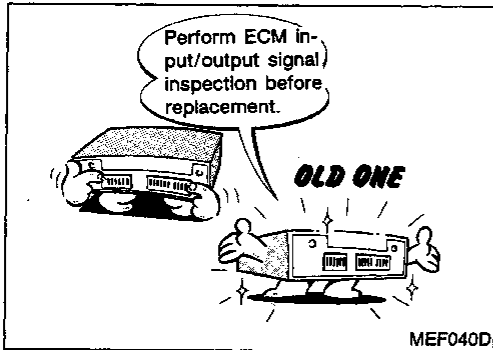
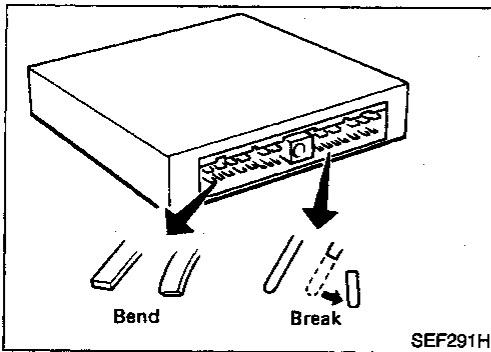
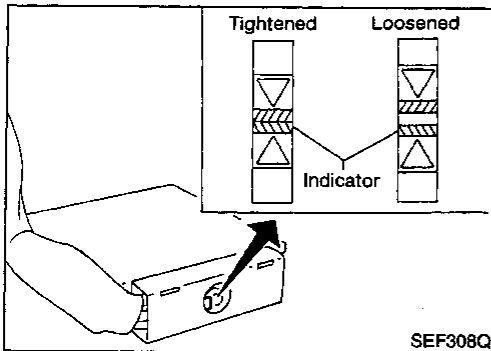
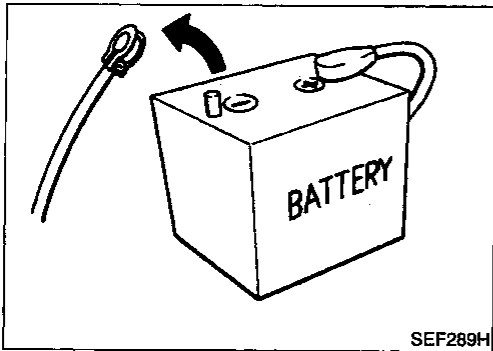

## Precautions

NEEC0065

- Before connecting or disconnecting the ECM harness connector, turn ignition switch OFF and disconnect negative battery terminal. Failure to do so may damage the ECM because battery voltage is applied to ECM even if ignition switch is turned off.
- When connecting ECM harness connector, tighten securing bolt until the gap between orange indicators disappears.  
⚙️ : 3 - 5 N·m (0.3 - 0.5 kg·m, 26 - 43 in·lb)
- When connecting or disconnecting pin connectors into or from ECM, take care not to damage pin terminals (bend or break).  
Make sure that there are not any bends or breaks on ECM pin terminal, when connecting pin connectors.
- Before replacing ECM, perform "ECM Terminals and Reference Value" inspection and make sure ECM functions properly. Refer to EC-106.
- After performing each TROUBLE DIAGNOSIS, perform "DTC Confirmation Procedure" or "Overall Function Check".  
The DTC should not be displayed in the "DTC Confirmation Procedure" if the repair is completed. The "Overall Function Check" should be a good result if the repair is completed.



# PRECAUTIONS

Precautions (Cont'd)

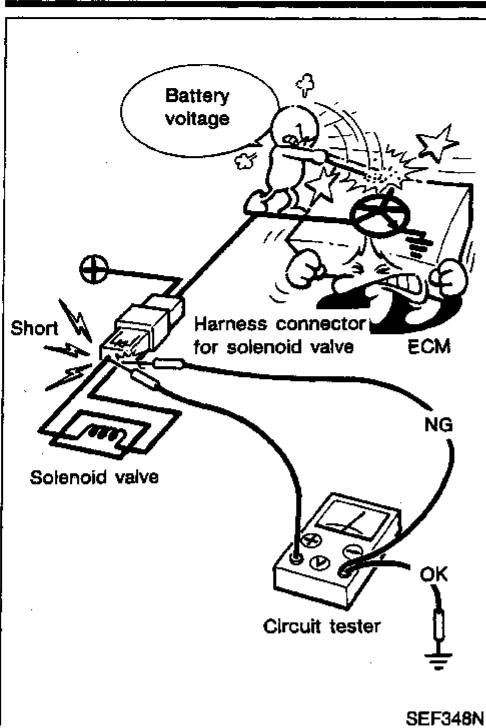

- When measuring ECM signals with a circuit tester, never allow the two tester probes to contact. Accidental contact of probes will cause a short circuit and damage the ECM power transistor.

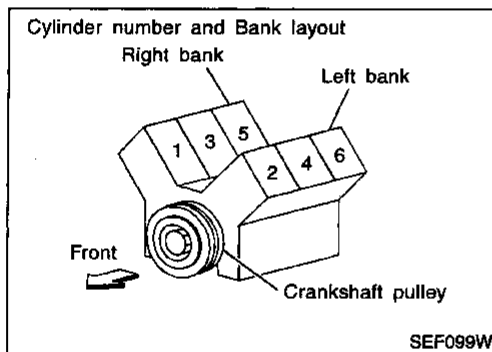

- Regarding model D22, "-B1" indicates the right bank and "-B2" indicates the left bank as shown in the figure.

## Wiring Diagrams and Trouble Diagnosis

NEEC0006

When you read Wiring diagrams, refer to the followings:

- "HOW TO READ WIRING DIAGRAMS" in G1 section
- "POWER SUPPLY ROUTING" for power distribution circuit in EL section

When you perform trouble diagnosis, refer to the followings:

- "HOW TO FOLLOW TEST GROUP IN TROUBLE DIAGNOSIS" in G1 section
- "HOW TO PERFORM EFFICIENT DIAGNOSIS FOR AN ELECTRICAL INCIDENT" in G1 section

GI  
MA  
EM  
LC  
EC  
FE  
CL  
MT  
AT  
TF  
PD  
FA  
RA  
BR  
ST  
RS  
BT  
HA  
EL  
IDX

# PREPARATION

Special Service Tools

## Special Service Tools

NEEC0007

The actual shapes of Kent-Moore tools may differ from those of special service tools illustrated here.

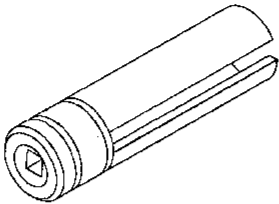
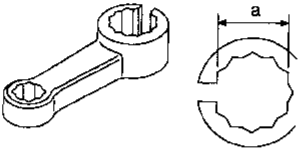
Tool number (Kent-Moore No.) Tool name	Description
KV10117100 (J36471-A) Heated oxygen sensor wrench	 <p data-bbox="922 321 1417 380">Loosening or tightening front heated oxygen sensor with 22 mm (0.87 in) hexagon nut</p> <p data-bbox="399 552 456 575">NT379</p>
KV10114400 (J-38365) Heated oxygen sensor wrench	 <p data-bbox="922 585 1430 644">Loosening or tightening rear heated oxygen sensor a: 22 mm (0.87 in)</p> <p data-bbox="399 758 456 781">NT636</p>

## Commercial Service Tools

NEEC0008

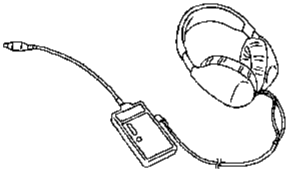
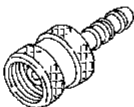
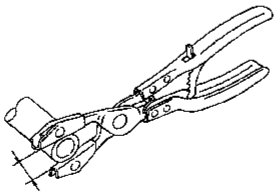
Tool name (Kent-Moore No.)	Description
Leak detector (J41416)	 <p data-bbox="919 938 1157 961">Locating the EVAP leak</p> <p data-bbox="394 1178 451 1203">NT703</p>
EVAP service port adapter (J41413-OBD)	 <p data-bbox="915 1213 1406 1272">Applying positive pressure through EVAP service port</p> <p data-bbox="394 1455 451 1478">NT704</p>
Hose clipper	 <p data-bbox="505 1682 756 1705">Approx. 20 mm (0.79 in)</p> <p data-bbox="912 1488 1406 1598">Clamping the EVAP purge hose between the fuel tank and EVAP canister applied to DTC P1440 [EVAP control system (small leak-positive pressure)]</p> <p data-bbox="394 1730 451 1755">NT720</p>

# PREPARATION

Commercial Service Tools (Cont'd)

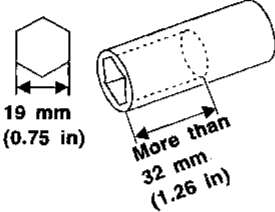
Tool name (Kent-Moore No.)	Description	
Fuel filler cap adapter	 <p data-bbox="987 216 1466 268">Checking fuel tank vacuum relief valve opening pressure</p> <p data-bbox="464 457 521 478">NT653</p>	<p data-bbox="1560 149 1588 174">GI</p> <p data-bbox="1560 239 1601 264">MA</p> <p data-bbox="1560 329 1601 354">EM</p> <p data-bbox="1560 420 1601 445">LC</p>
Socket wrench	 <p data-bbox="987 489 1479 541">Removing and installing engine coolant temperature sensor</p> <p data-bbox="464 730 521 751">NT705</p>	<p data-bbox="1555 506 1596 531"><b>EC</b></p> <p data-bbox="1560 596 1601 621">FE</p> <p data-bbox="1560 686 1601 711">CL</p> <p data-bbox="1560 777 1601 802">MT</p> <p data-bbox="1560 867 1601 892">AT</p> <p data-bbox="1560 957 1601 982">TF</p> <p data-bbox="1560 1047 1601 1073">PD</p> <p data-bbox="1560 1138 1601 1163">FA</p> <p data-bbox="1560 1228 1601 1253">RA</p> <p data-bbox="1560 1318 1601 1344">BR</p> <p data-bbox="1560 1409 1601 1434">ST</p> <p data-bbox="1560 1499 1601 1524">RS</p> <p data-bbox="1560 1589 1601 1614">BT</p> <p data-bbox="1560 1680 1601 1705">HA</p> <p data-bbox="1560 1770 1601 1795">EL</p> <p data-bbox="1560 1860 1601 1885">IDX</p>

# ENGINE AND EMISSION CONTROL OVERALL SYSTEM

Engine Control Component Parts Location

## Engine Control Component Parts Location

NEEC0009

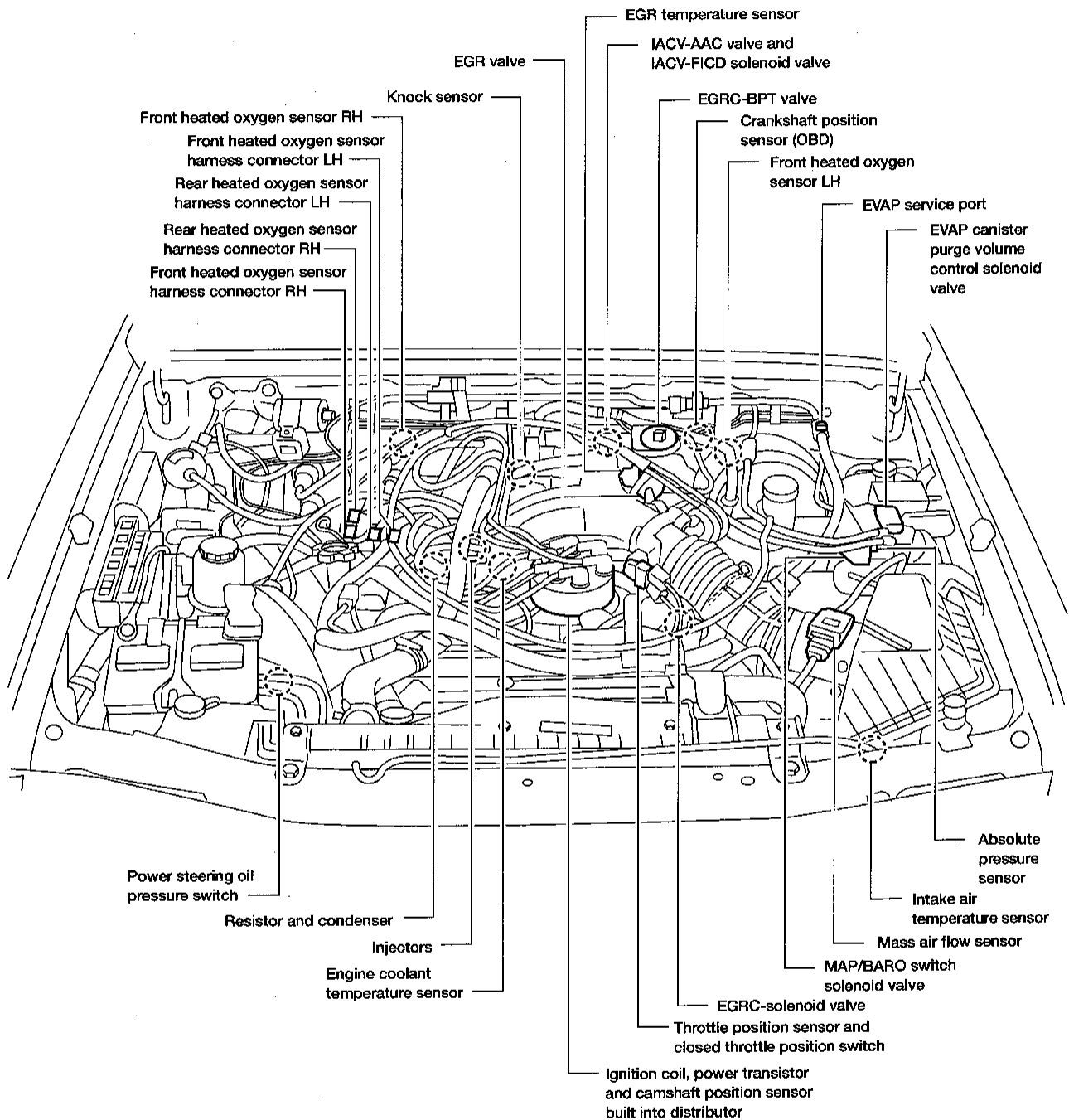

AEC628A

# ENGINE AND EMISSION CONTROL OVERALL SYSTEM

Engine Control Component Parts Location (Cont'd)

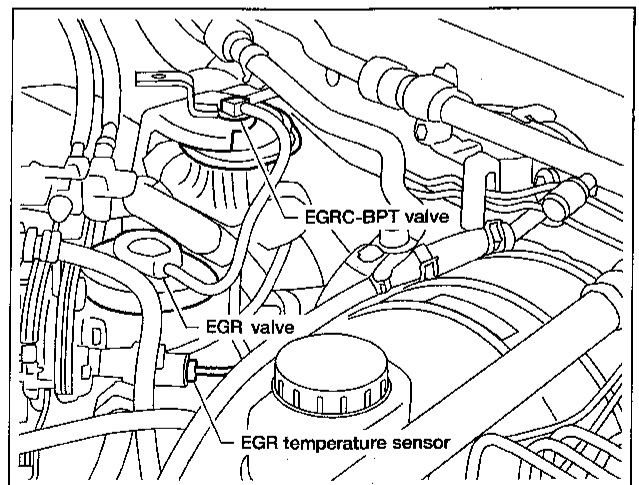
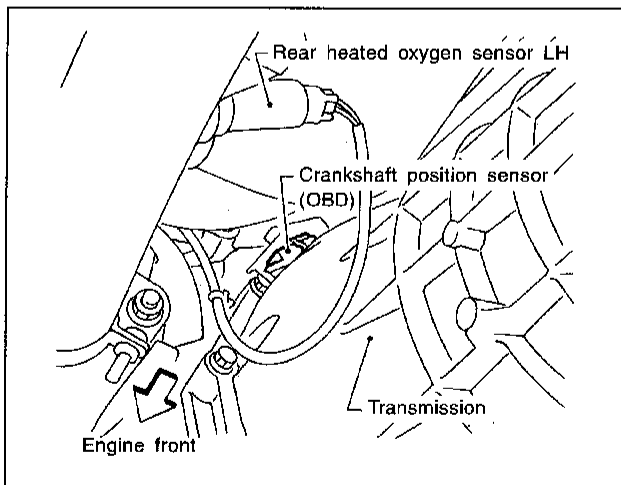
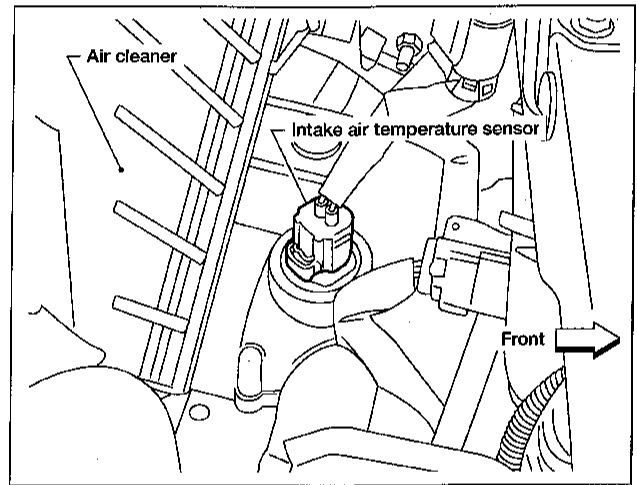
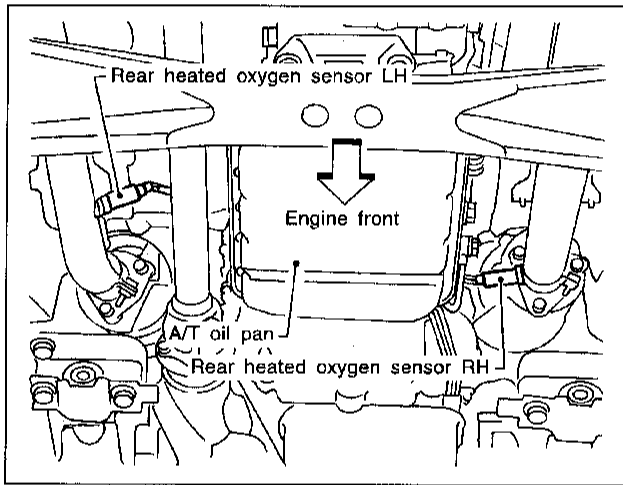
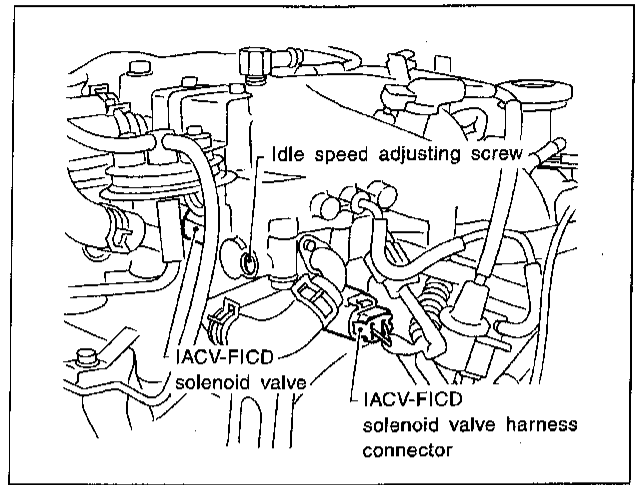
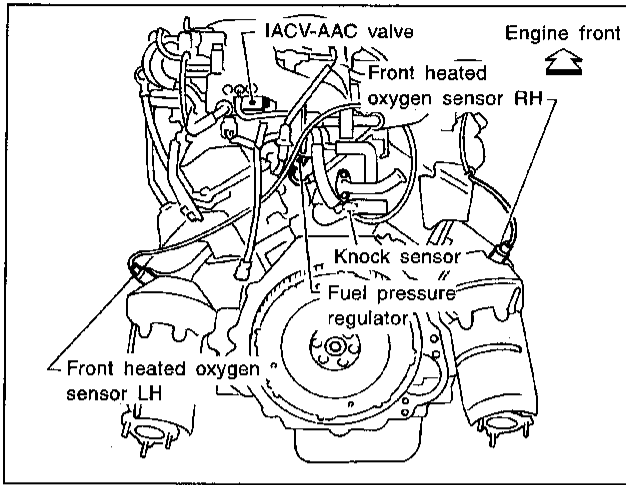

GI  
MA  
EM  
LC  
**EC**  
FE  
CL  
MT  
AT  
TF  
PD  
FA  
RA  
BR  
ST  
RS  
BT  
HA  
EL  
IDX

AEC629A

# ENGINE AND EMISSION CONTROL OVERALL SYSTEM

Circuit Diagram

## Circuit Diagram

NEEC0010

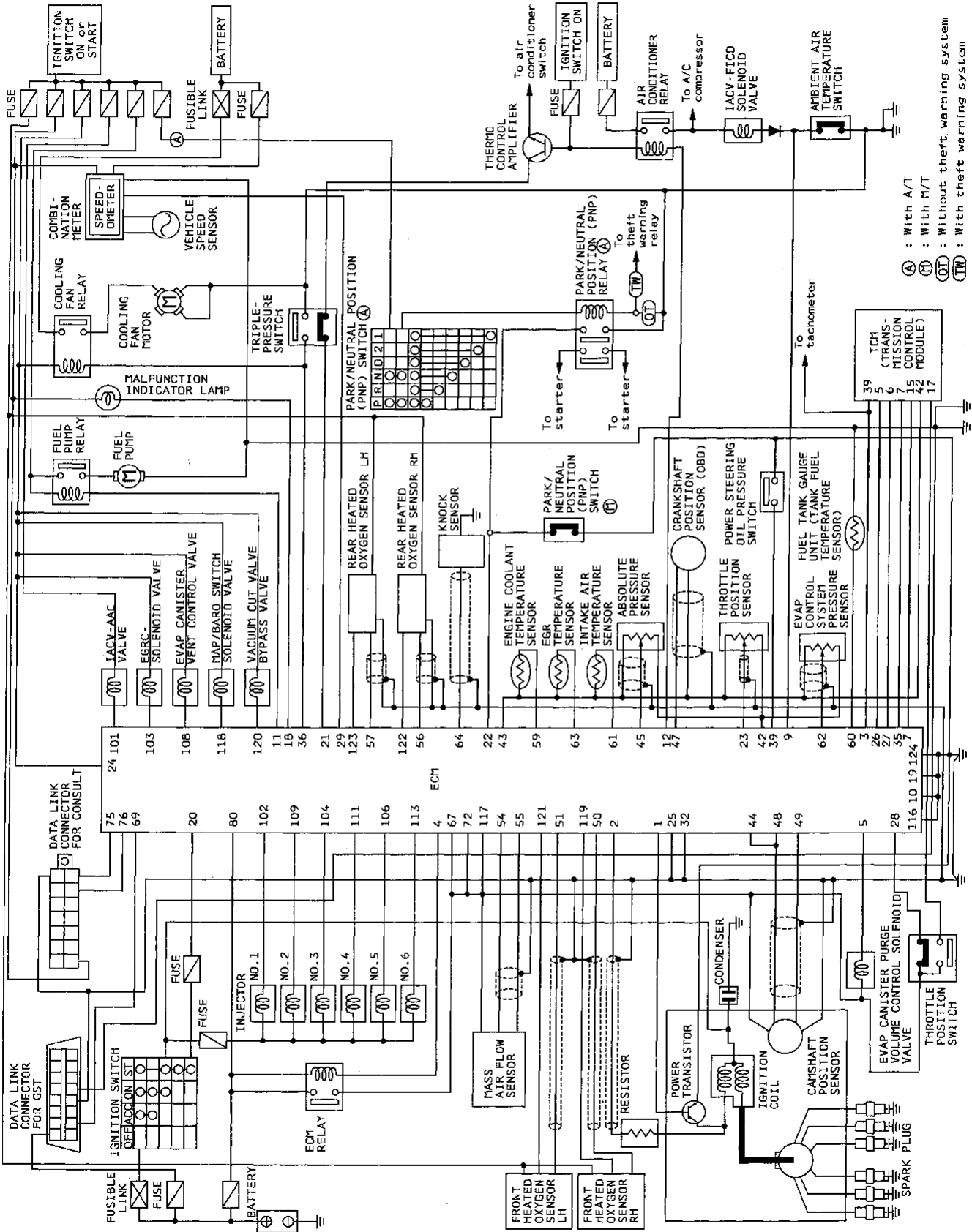

AEC751A

ENGINE AND EMISSION CONTROL OVERALL SYSTEM

System Diagram

System Diagram

NEEC0011

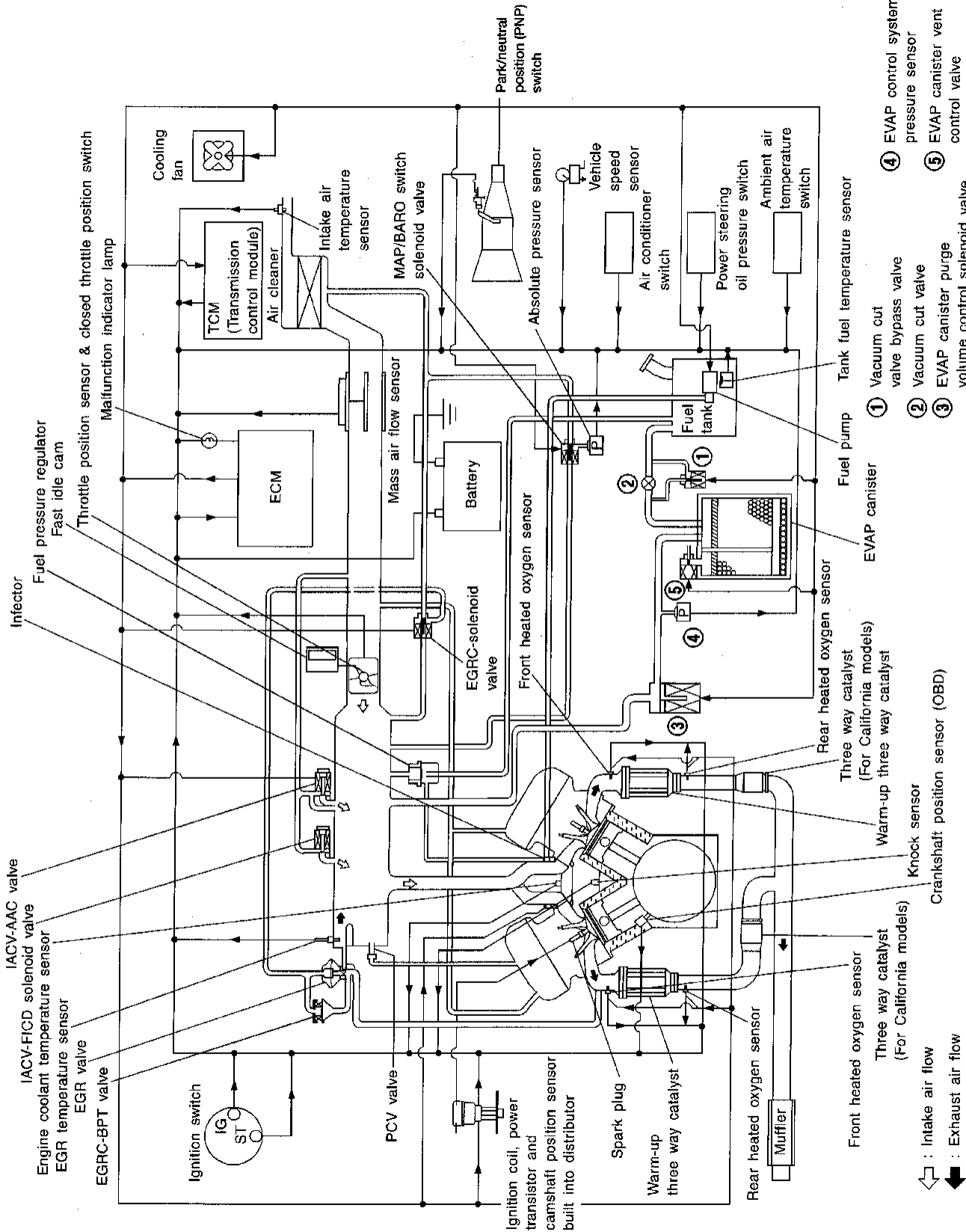

GI  
MA  
EM  
LC  
**EC**  
FE  
CL  
MT  
AT  
TF  
PD  
FA  
RA  
BR  
ST  
RS  
BT  
HA  
EL

AEC883A

# ENGINE AND EMISSION CONTROL OVERALL SYSTEM

Vacuum Hose Drawing

## Vacuum Hose Drawing

NEEC0012

Refer to "System Diagram", EC-17 for Vacuum Control System.

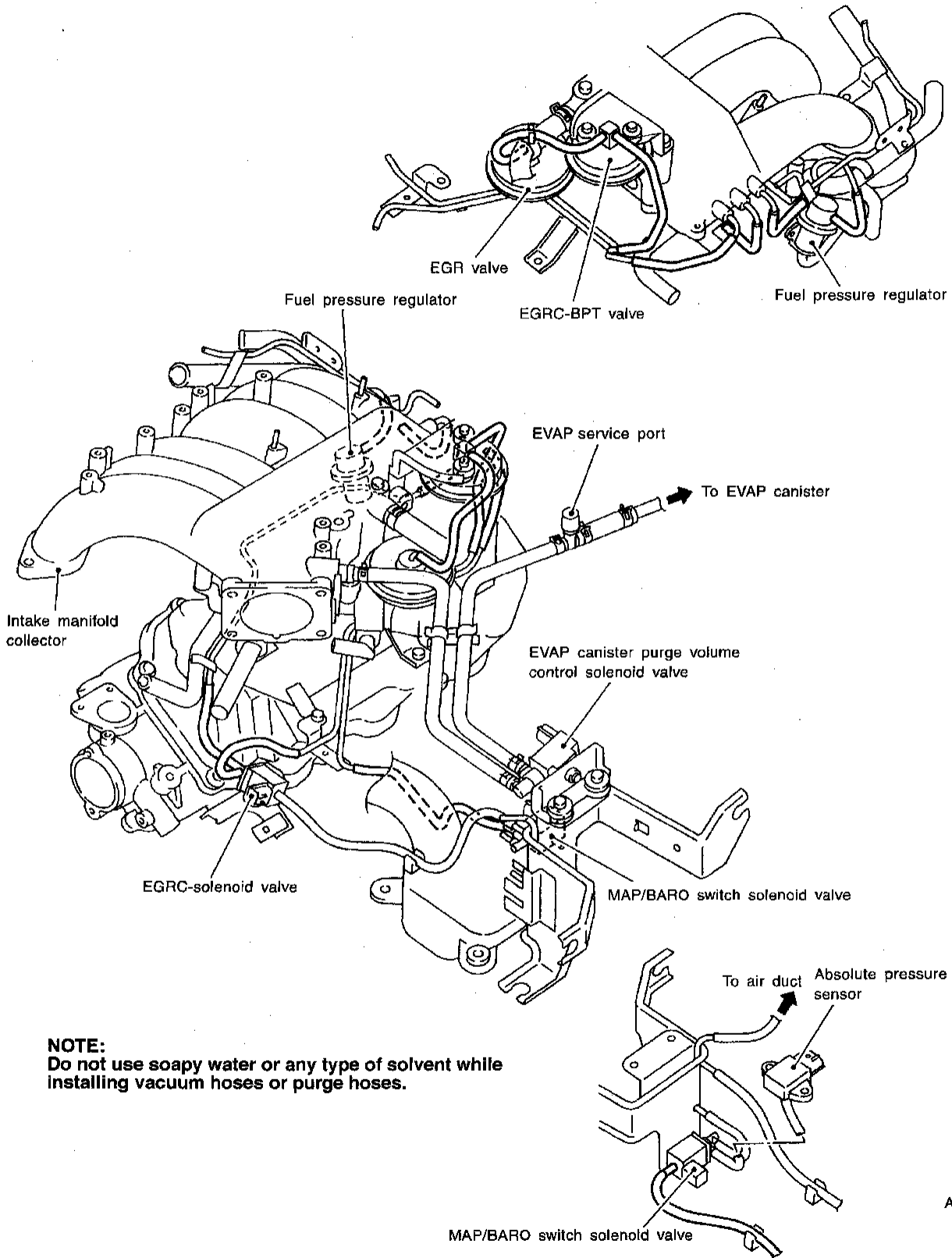



# ENGINE AND EMISSION CONTROL OVERALL SYSTEM

System Chart

## System Chart

NEEC0013

Input (Sensor)	ECM Function	Output (Actuator)
<ul style="list-style-type: none"> <li>• Camshaft position sensor</li> <li>• Mass air flow sensor</li> <li>• Engine coolant temperature sensor</li> <li>• Front heated oxygen sensor</li> <li>• Ignition switch</li> <li>• Throttle position sensor</li> <li>• Closed throttle position switch *4</li> <li>• Park/neutral position (PNP) switch</li> <li>• Air conditioner switch</li> <li>• Knock sensor</li> <li>• EGR temperature sensor *1</li> <li>• Intake air temperature sensor</li> <li>• Absolute pressure sensor</li> <li>• EVAP control system pressure sensor *1</li> <li>• Battery voltage</li> <li>• Power steering oil pressure switch</li> <li>• Vehicle speed sensor</li> <li>• Tank fuel temperature sensor *1</li> <li>• Crankshaft position sensor (OBD) *1</li> <li>• Rear heated oxygen sensor *3</li> <li>• TCM (Transmission control module) *2</li> <li>• Ambient air temperature switch</li> </ul>	Fuel injection & mixture ratio control	Injectors
	Distributor ignition system	Power transistor
	Idle air control system	IACV-AAC valve and IACV-FICD solenoid valve
	Fuel pump control	Fuel pump relay
	Front heated oxygen sensor monitor & on board diagnostic system	MIL (On the instrument panel)
	EGR control	EGRC-solenoid valve
	Front heated oxygen sensor heater control	Front heated oxygen sensor heater
	Rear heated oxygen sensor heater control	Rear heated oxygen sensor heater
	EVAP canister purge flow control	EVAP canister purge volume control solenoid valve
	Air conditioning cut control	Air conditioner relay
	Cooling fan control	Cooling fan relays
	ON BOARD DIAGNOSIS for EVAP system	<ul style="list-style-type: none"> <li>• EVAP canister vent control valve</li> <li>• Vacuum cut valve bypass valve</li> <li>• MAP/BARO switch solenoid valve</li> </ul>

\*1: These sensors are not used to control the engine system. They are used only for the on board diagnosis.

\*2: The DTC related to A/T will be sent to ECM.

\*3: This sensor is not used to control the engine system under normal conditions.

\*4: This switch will operate in place of the throttle position sensor to control EVAP parts if the sensor malfunctions.

GI  
MA  
EM  
LC  
EC  
FE  
CL  
MT  
AT  
TF  
PD  
FA  
RA  
BR  
ST  
RS  
BT  
HA  
EL  
IDX

# ENGINE AND EMISSION BASIC CONTROL SYSTEM DESCRIPTION

Multiport Fuel Injection (MFI) System

## Multiport Fuel Injection (MFI) System

### DESCRIPTION

NEEC0014

### Input/Output Signal Chart

NEEC0014S01

Sensor	Input Signal to ECM	ECM function	Actuator
Camshaft position sensor	Engine speed and piston position	Fuel injection & mixture ratio control	Injectors
Mass air flow sensor	Amount of intake air		
Engine coolant temperature sensor	Engine coolant temperature		
Front heated oxygen sensor	Density of oxygen in exhaust gas		
Throttle position sensor	Throttle position Throttle valve idle position		
Park/neutral position (PNP) switch	Gear position		
Vehicle speed sensor	Vehicle speed		
Ignition switch	Start signal		
Air conditioner switch	Air conditioner operation		
Knock sensor	Engine knocking condition		
Battery	Battery voltage		
Absolute pressure sensor	Manifold absolute pressure Ambient air barometric pressure		
Power steering oil pressure switch	Power steering operation		
Rear heated oxygen sensor*	Density of oxygen in exhaust gas		

\* Under normal conditions, this sensor is not for engine control operation.

### Basic Multiport Fuel Injection System

NEEC0014S02

The amount of fuel injected from the fuel injector is determined by the ECM. The ECM controls the length of time the valve remains open (injection pulse duration). The amount of fuel injected is a program value in the ECM memory. The program value is preset by engine operating conditions. These conditions are determined by input signals (for engine speed and intake air) from both the camshaft position sensor and the mass air flow sensor.

### Various Fuel Injection Increase/Decrease Compensation

NEEC0014S03

In addition, the amount of fuel injected is compensated to improve engine performance under various operating conditions as listed below.

#### <Fuel increase>

- During warm-up
- When starting the engine
- During acceleration
- Hot-engine operation
- When selector lever is changed from "N" to "D"
- High-load, high-speed operation

#### <Fuel decrease>

- During deceleration
- During high engine speed operation

# ENGINE AND EMISSION BASIC CONTROL SYSTEM DESCRIPTION

Multiport Fuel Injection (MFI) System (Cont'd)

## Mixture Ratio Feedback Control (Closed loop control)

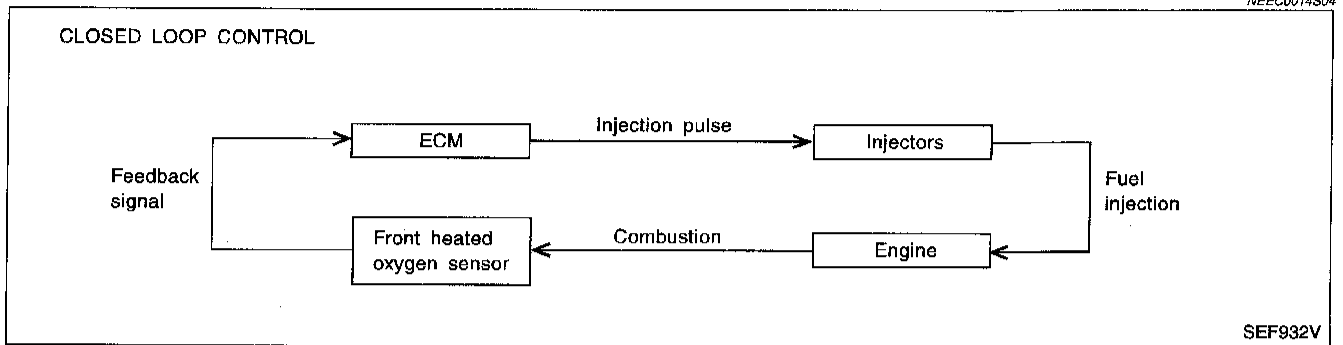

The mixture ratio feedback system provides the best air-fuel mixture ratio for driveability and emission control. The warm-up three way catalyst can then better reduce CO, HC and NOx emissions. This system uses a front heated oxygen sensor in the exhaust manifold to monitor if the engine operation is rich or lean. The ECM adjusts the injection pulse width according to the sensor voltage signal. For more information about the front heated oxygen sensor, refer to EC-166. This maintains the mixture ratio within the range of stoichiometric (ideal air-fuel mixture).

This stage is referred to as the closed loop control condition.

Rear heated oxygen sensor is located downstream of the warm-up three way catalyst. Even if the switching characteristics of the front heated oxygen sensor shift, the air-fuel ratio is controlled to stoichiometric by the signal from the rear heated oxygen sensor.

### Open Loop Control

The open loop system condition refers to when the ECM detects any of the following conditions. Feedback control stops in order to maintain stabilized fuel combustion.

- Deceleration and acceleration
- High-load, high-speed operation
- Malfunction of front heated oxygen sensor or its circuit
- Insufficient activation of front heated oxygen sensor at low engine coolant temperature
- High engine coolant temperature
- During warm-up
- When starting the engine

### Mixture Ratio Self-learning Control

The mixture ratio feedback control system monitors the mixture ratio signal transmitted from the front heated oxygen sensor. This feedback signal is then sent to the ECM. The ECM controls the basic mixture ratio as close to the theoretical mixture ratio as possible. However, the basic mixture ratio is not necessarily controlled as originally designed. Both manufacturing differences (i.e., mass air flow sensor hot wire) and characteristic changes during operation (i.e., injector clogging) directly affect mixture ratio.

Accordingly, the difference between the basic and theoretical mixture ratios is monitored in this system. This is then computed in terms of "injection pulse duration" to automatically compensate for the difference between the two ratios.

"Fuel trim" refers to the feedback compensation value compared against the basic injection duration. Fuel trim includes short term fuel trim and long term fuel trim.

"Short term fuel trim" is the short-term fuel compensation used to maintain the mixture ratio at its theoretical value. The signal from the front heated oxygen sensor indicates whether the mixture ratio is RICH or LEAN compared to the theoretical value. The signal then triggers a reduction in fuel volume if the mixture ratio is rich, and an increase in fuel volume if it is lean.

"Long term fuel trim" is overall fuel compensation carried out long-term to compensate for continual deviation of the short term fuel trim from the central value. Such deviation will occur due to individual engine differences, wear over time and changes in the usage environment.

# ENGINE AND EMISSION BASIC CONTROL SYSTEM DESCRIPTION

## Multiport Fuel Injection (MFI) System (Cont'd)

### Fuel Injection Timing

NEEC0014S07

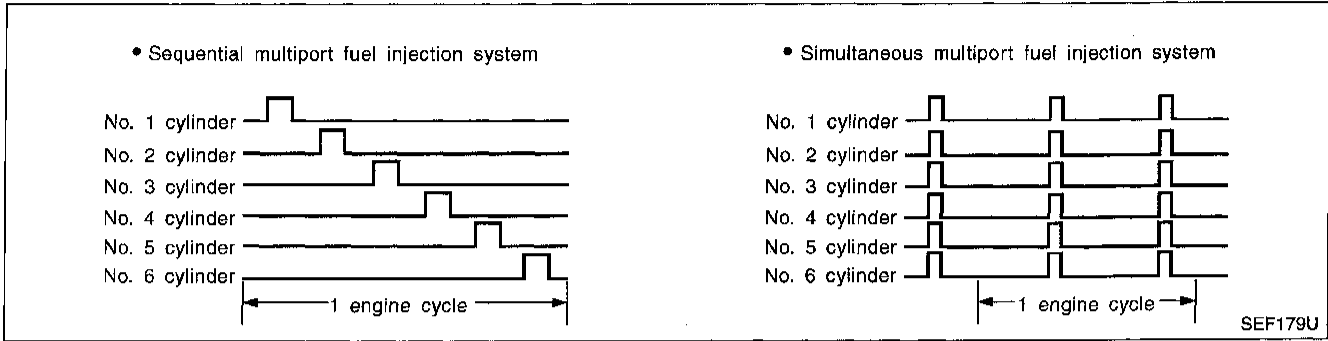

Two types of systems are used.

#### Sequential Multiport Fuel Injection System

NEEC0014S0701

Fuel is injected into each cylinder during each engine cycle according to the firing order. This system is used when the engine is running.

#### Simultaneous Multiport Fuel Injection System

NEEC0014S0702

Fuel is injected simultaneously into all six cylinders twice each engine cycle. In other words, pulse signals of the same width are simultaneously transmitted from the ECM.

The six injectors will then receive the signals two times for each engine cycle.

This system is used when the engine is being started and/or if the fail-safe system (CPU) is operating.

#### Fuel Shut-off

NEEC0014S08

Fuel to each cylinder is cut off during deceleration or operation of the engine at excessively high speeds.

## Distributor Ignition (DI) System

### DESCRIPTION

NEEC0015

#### Input/Output Signal Chart

NEEC0015S01

Sensor	Input Signal to ECM	ECM function	Actuator
Camshaft position sensor	Engine speed and piston position	Ignition timing control	Power transistor
Mass air flow sensor	Amount of intake air		
Engine coolant temperature sensor	Engine coolant temperature		
Throttle position sensor	Throttle position Throttle valve idle position		
Vehicle speed sensor	Vehicle speed		
Ignition switch	Start signal		
Knock sensor	Engine knocking		
Park/neutral position (PNP) switch	Gear position		
Battery	Battery voltage		

# ENGINE AND EMISSION BASIC CONTROL SYSTEM DESCRIPTION

Distributor Ignition (DI) System (Cont'd)

## System Description

NEEC0015S02

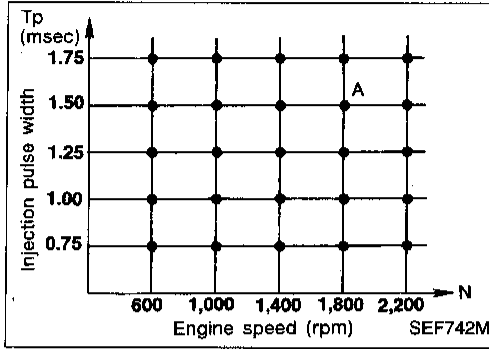

The ignition timing is controlled by the ECM to maintain the best air-fuel ratio for every running condition of the engine. The ignition timing data is stored in the ECM. This data forms the map shown.

The ECM receives information such as the injection pulse width and camshaft position sensor signal. Computing this information, ignition signals are transmitted to the power transistor.

e.g., N: 1,800 rpm, Tp: 1.50 msec

A °BTDC

During the following conditions, the ignition timing is revised by the ECM according to the other data stored in the ECM.

- At starting
- During warm-up
- At idle
- At low battery voltage
- During acceleration

The knock sensor retard system is designed only for emergencies. The basic ignition timing is programmed within the anti-knocking zone, if recommended fuel is used under dry conditions. The retard system does not operate under normal driving conditions. If engine knocking occurs, the knock sensor monitors the condition. The signal is transmitted to the ECM. The ECM retards the ignition timing to eliminate the knocking condition.

## Air Conditioning Cut Control

### DESCRIPTION

### Input/Output Signal Chart

NEEC0016

NEEC0016S01

Sensor	Input Signal to ECM	ECM function	Actuator
Air conditioner switch	Air conditioner "ON" signal	Air conditioner cut control	Air conditioner relay
Throttle position sensor	Throttle valve opening angle		
Camshaft position sensor	Engine speed		
Engine coolant temperature sensor	Engine coolant temperature		
Ignition switch	Start signal		
Vehicle speed sensor	Vehicle speed		
Power steering oil pressure switch	Power steering operation		

### System Description

NEEC0016S02

This system improves engine operation when the air conditioner is used.

Under the following conditions, the air conditioner is turned off.

- When the accelerator pedal is fully depressed.
- When cranking the engine.
- At high engine speeds.
- When the engine coolant temperature becomes excessively high.
- When operating power steering during low engine speed or low vehicle speed.
- When engine speed is excessively low.

# ENGINE AND EMISSION BASIC CONTROL SYSTEM DESCRIPTION

Fuel Cut Control (at no load & high engine speed)

## Fuel Cut Control (at no load & high engine speed)

### DESCRIPTION

#### Input/Output Signal Chart

NEEC0017

NEEC0017S01

Sensor	Input Signal to ECM	ECM function	Actuator
Vehicle speed sensor	Vehicle speed	Fuel cut control	Injectors
Park/neutral position (PNP) switch	Neutral position		
Throttle position sensor	Throttle position		
Engine coolant temperature sensor	Engine coolant temperature		
Camshaft position sensor	Engine speed		

If the engine speed is above 2,500 rpm with no load (for example, in neutral and engine speed over 2,500 rpm) fuel will be cut off after some time. The exact time when the fuel is cut off varies based on engine speed. Fuel cut will operate until the engine speed reaches 2,000 rpm, then fuel cut is cancelled.

#### NOTE:

This function is different from deceleration control listed under "Multiport Fuel Injection (MFI) System", EC-20.

## Evaporative Emission System

### DESCRIPTION

NEEC0018

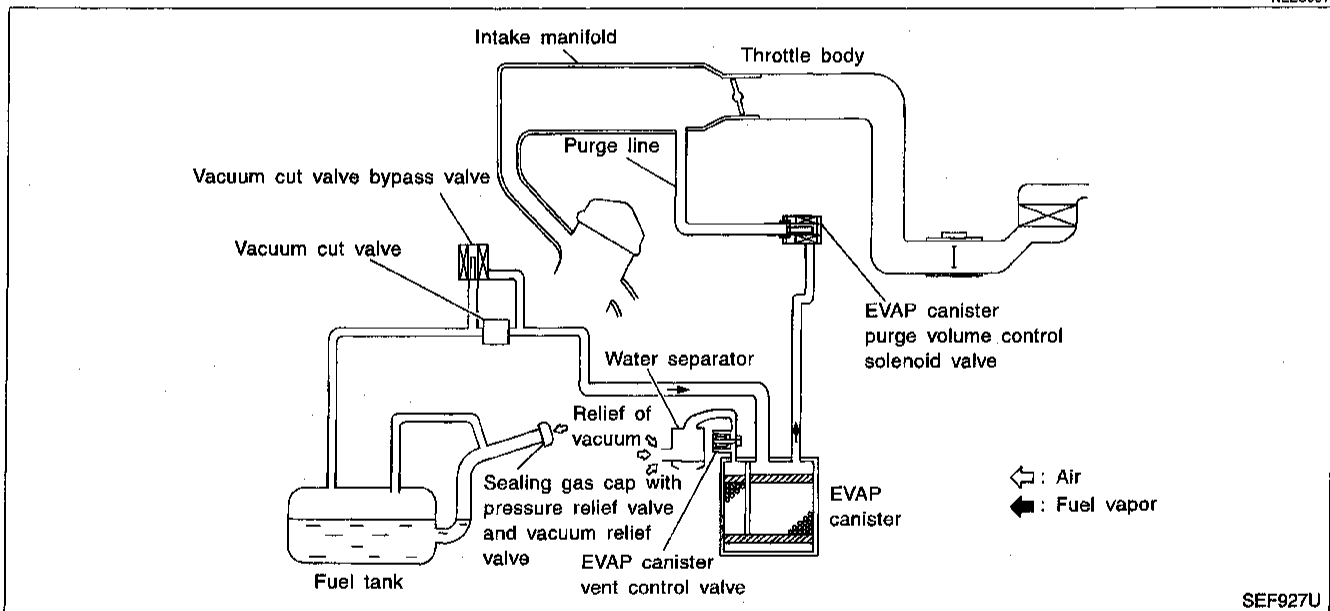

SEF927U

The evaporative emission system is used to reduce hydrocarbons emitted into the atmosphere from the fuel system. This reduction of hydrocarbons is accomplished by activated charcoals in the EVAP canister.

The fuel vapor in the sealed fuel tank is led into the EVAP canister which contains activated carbon and the vapor is stored there when the engine is not operating or when refueling to the fuel tank.

The vapor in the EVAP canister is purged by the air through the purge line to the intake manifold when the engine is operating. EVAP canister purge volume control solenoid valve is controlled by ECM. When the engine operates, the flow rate of vapor controlled by EVAP canister purge volume control solenoid valve is proportionally regulated as the air flow increases.

EVAP canister purge volume control solenoid valve also shuts off the vapor purge line during decelerating and idling.

# ENGINE AND EMISSION BASIC CONTROL SYSTEM DESCRIPTION

Evaporative Emission System (Cont'd)

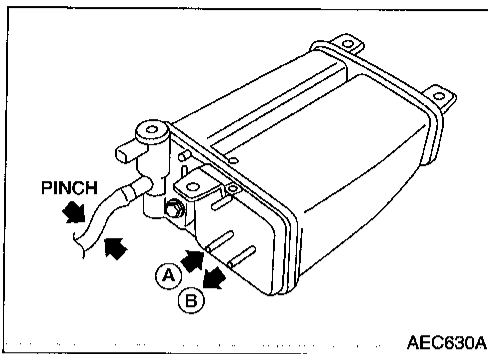

## INSPECTION

### EVAP Canister

NEEC0019

NEEC0019S01

Check EVAP canister as follows:

1. Pinch the fresh air hose.
2. Blow air into port A and check that it flows freely out of port B.

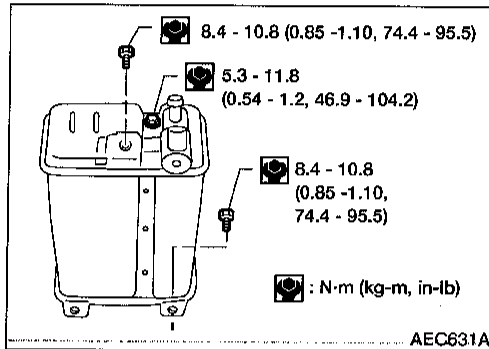

## Tightening Torque

NEEC0019S02

Tighten EVAP canister as shown in the figure.

**Make sure new O-ring is installed properly between EVAP canister and EVAP canister vent control valve.**

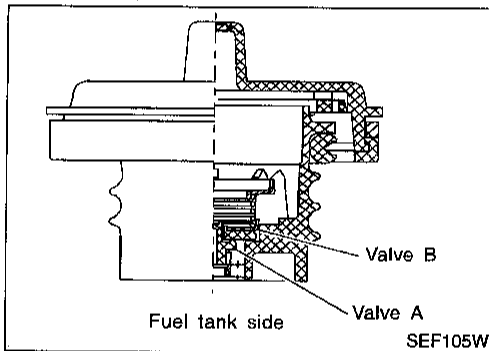

## Fuel Tank Vacuum Relief Valve (Built into fuel filler cap)

NEEC0019S03

1. Wipe clean valve housing.
2. Check valve opening pressure and vacuum.

### Pressure:

15.3 - 20.0 kPa (0.156 - 0.204 kg/cm<sup>2</sup>, 2.22 - 2.90 psi)

### Vacuum:

-6.0 to -3.3 kPa (-0.061 to -0.034 kg/cm<sup>2</sup>, -0.87 to -0.48 psi)

3. If out of specification, replace fuel filler cap as an assembly.

### CAUTION:

**Use only a genuine fuel filler cap as a replacement. If an incorrect fuel filler cap is used, the MIL may come on.**

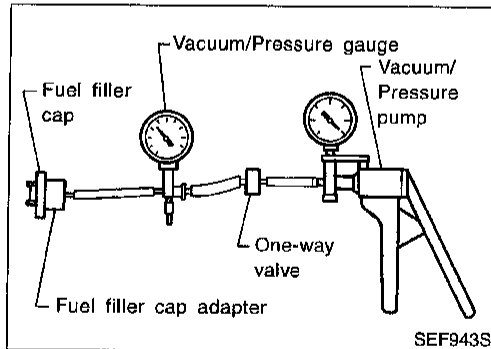

## Vacuum Cut Valve and Vacuum Cut Valve Bypass Valve

NEEC0019S05

Refer to EC-432.

## Evaporative Emission (EVAP) Canister Purge Volume Control Solenoid Valve

NEEC0019S06

Refer to EC-310.

## Tank Fuel Temperature Sensor

NEEC0019S08

Refer to EC-261.

# ENGINE AND EMISSION BASIC CONTROL SYSTEM DESCRIPTION

## Evaporative Emission System (Cont'd)

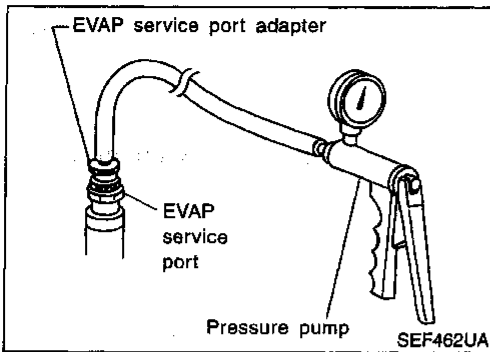

### Evap Service Port

Positive pressure is delivered to the EVAP system through the EVAP service port. If fuel vapor leakage in the EVAP system occurs, use a leak detector to locate the leak.

NEEC0019S09

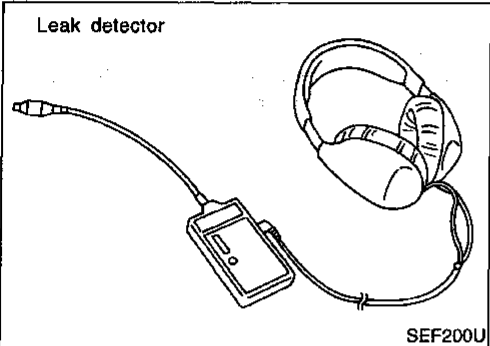

### How to Detect Fuel Vapor Leakage

#### CAUTION:

- Never use compressed air or a high pressure pump.
- Do not exceed 4.12 kPa (0.042 kg/cm<sup>2</sup>, 0.6 psi) of pressure in EVAP system.

NEEC0019S10

#### NOTE:

- Do not start engine.
- Improper installation of EVAP service port adapter to the EVAP service port may cause a leak.

#### Ⓢ With CONSULT

- 1) Attach the EVAP service port adapter securely to the EVAP service port.
- 2) Also attach the pressure pump and hose to the EVAP service port adapter.
- 3) Turn ignition switch "ON".
- 4) Select the "EVAP SYSTEM CLOSE" of "WORK SUPPORT MODE" with CONSULT.
- 5) Touch "START". A bar graph (Pressure indicating display) will appear on the screen.
- 6) Apply positive pressure to the EVAP system until the pressure indicator reaches the middle of the bar graph.
- 7) Remove EVAP service port adapter and hose with pressure pump.
- 8) Locate the leak using a leak detector. Refer to "EVAPORATIVE EMISSION LINE DRAWING", EC-28.

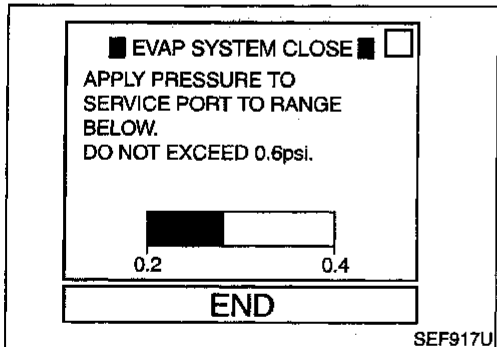
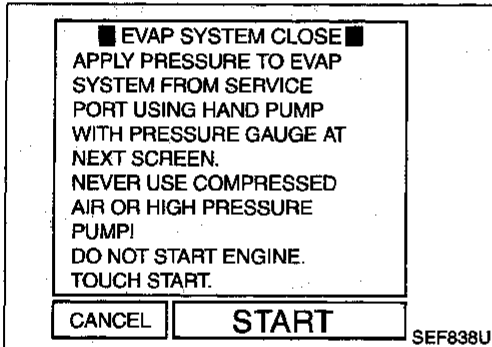



# ENGINE AND EMISSION BASIC CONTROL SYSTEM DESCRIPTION

Evaporative Emission System (Cont'd)

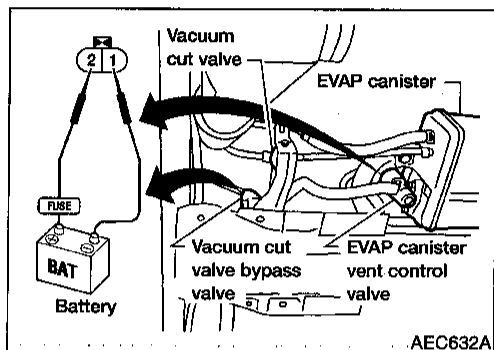
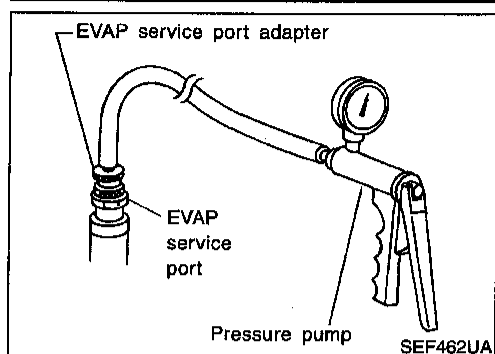

## ⊗ Without CONSULT

- 1) Attach the EVAP service port adapter securely to the EVAP service port.
- 2) Also attach the pressure pump with pressure gauge to the EVAP service port adapter.
- 3) Apply battery voltage to between the terminals of both EVAP canister vent control valve and vacuum cut valve bypass valve to make a closed EVAP system.
- 4) To locate the leak, deliver positive pressure to the EVAP system until pressure gauge points reach 1.38 - 2.76 kPa (0.014 - 0.028 kg/cm<sup>2</sup>, 0.2 - 0.4 psi).
- 5) Remove EVAP service port adapter and hose with pressure pump.
- 6) Locate the leak using a leak detector. Refer to "EVAPORATIVE EMISSION LINE DRAWING", EC-28.

GI  
MA  
EM  
LC  
EC  
FE  
CL  
MT  
AT  
TF  
PD  
FA  
RA  
BR  
ST  
RS  
BT  
HA  
EL  
IDX

# ENGINE AND EMISSION BASIC CONTROL SYSTEM DESCRIPTION

Evaporative Emission System (Cont'd)

## EVAPORATIVE EMISSION LINE DRAWING

NEEC0020

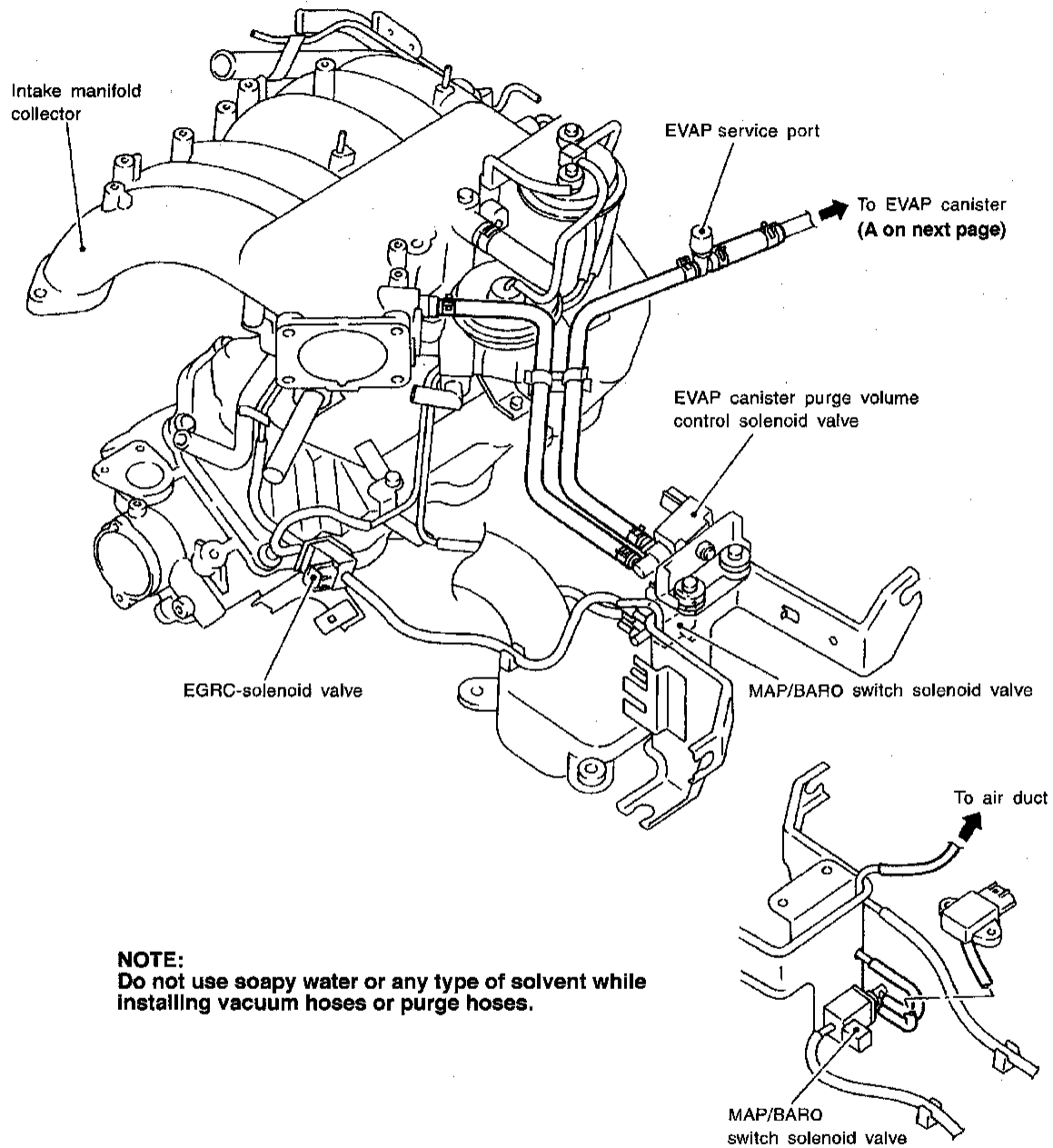

**NOTE:**  
Do not use soapy water or any type of solvent while installing vacuum hoses or purge hoses.

AEC885A

# ENGINE AND EMISSION BASIC CONTROL SYSTEM DESCRIPTION

Evaporative Emission System (Cont'd)

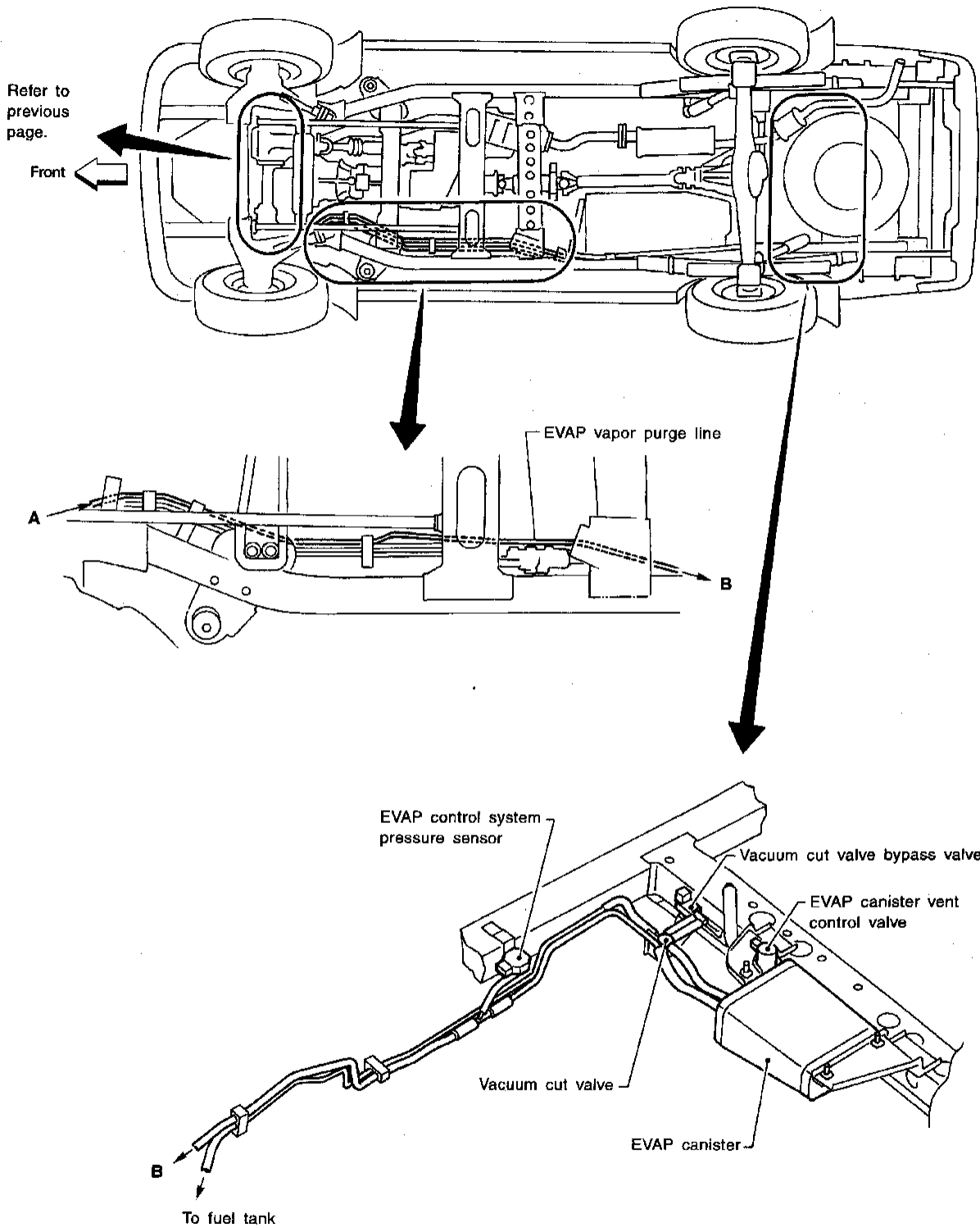

GI

MA

EM

LC

**EC**

FE

GL

MT

AT

TF

PD

FA

RA

BR

ST

RS

BT

HA

EL

IDX

AEC886A

# ENGINE AND EMISSION BASIC CONTROL SYSTEM DESCRIPTION

## Positive Crankcase Ventilation

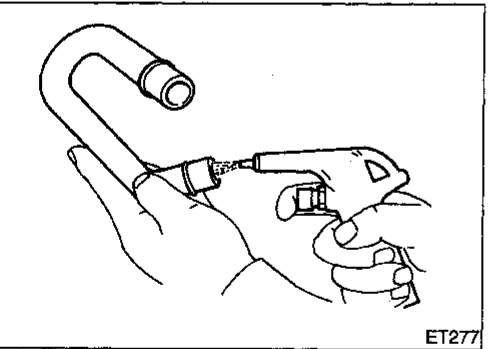
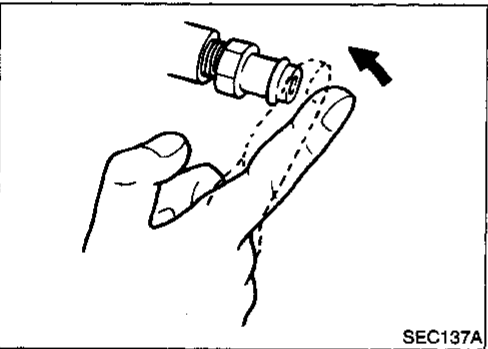
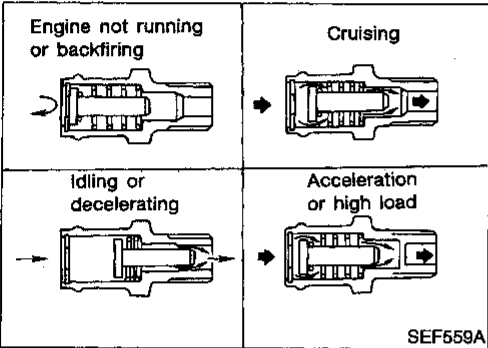
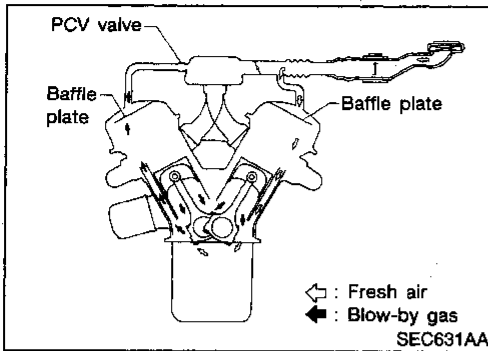

## Positive Crankcase Ventilation DESCRIPTION

NEEC0021

This system returns blow-by gas to the intake manifold. The positive crankcase ventilation (PCV) valve is provided to conduct crankcase blow-by gas to the intake manifold. During partial throttle operation of the engine, the intake manifold sucks the blow-by gas through the PCV valve. Normally, the capacity of the valve is sufficient to handle any blow-by and a small amount of ventilating air. The ventilating air is then drawn from the air inlet tubes into the crankcase. In this process the air passes through the hose connecting air inlet tubes to rocker cover. Under full-throttle condition, the manifold vacuum is insufficient to draw the blow-by flow through the valve. The flow goes through the hose connection in the reverse direction. On vehicles with an excessively high blow-by, the valve does not meet the requirement. This is because some of the flow will go through the hose connection to the air inlet tubes under all conditions.

## INSPECTION

NEEC0022

### PCV (Positive Crankcase Ventilation) Valve

NEEC0022S01

With engine running at idle, remove PCV valve ventilation hose from PCV valve; if the valve is working properly, a hissing noise will be heard as air passes through it and a strong vacuum should be felt immediately when a finger is placed over valve inlet.

### PCV Valve Ventilation Hose

NEEC0022S02

1. Check hoses and hose connections for leaks.
2. Disconnect all hoses and clean with compressed air. If any hose cannot be freed of obstructions, replace.

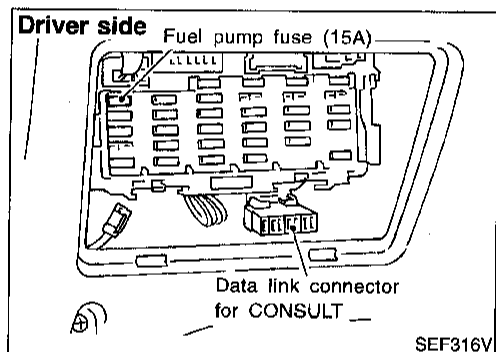
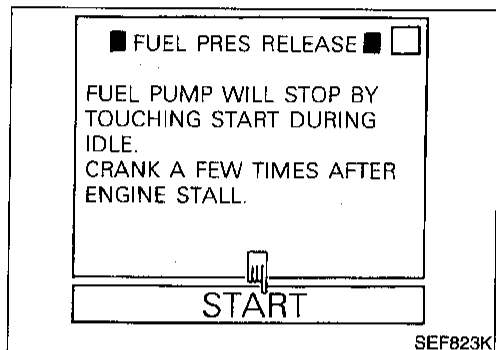
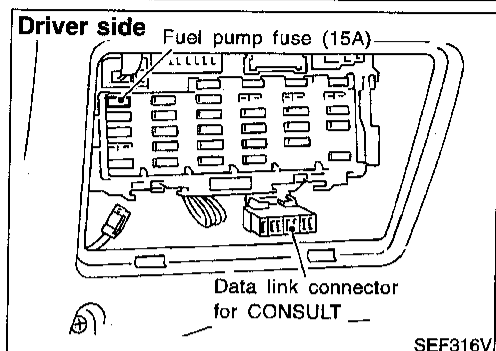

## Fuel Pressure Release

NEEC0023

Before disconnecting fuel line, release fuel pressure from fuel line to eliminate danger.

### Ⓜ WITH CONSULT

NEEC0023S01

1. Turn ignition switch "ON".
2. Perform "FUEL PRESSURE RELEASE" in "WORK SUPPORT" mode with CONSULT.
3. Start engine.
4. After engine stalls, crank it two or three times to release all fuel pressure.
5. Turn ignition switch "OFF".

### ⓧ WITHOUT CONSULT

NEEC0023S02

1. Remove fuel pump fuse located in fuse box.
2. Start engine.
3. After engine stalls, crank it two or three times to release all fuel pressure.
4. Turn ignition switch "OFF".
5. Reinstall fuel pump fuse after servicing fuel system.

## Fuel Pressure Check

NEEC0024

- When reconnecting fuel line, always use new clamps.
  - Make sure that clamp screw does not contact adjacent parts.
  - Use a torque driver to tighten clamps.
  - Use Pressure Gauge to check fuel pressure.
  - Do not perform fuel pressure check with system operating. Fuel pressure gauge may indicate false readings.
1. Release fuel pressure to zero.
  2. Disconnect fuel hose between fuel filter and fuel tube (engine side).

GI  
MA  
EM  
LC  
EC  
FE  
CL  
MT  
AT  
TF  
PD  
FA  
RA  
BR  
ST  
RS  
BT  
HA  
EL  
IDX

## BASIC SERVICE PROCEDURE

### Fuel Pressure Check (Cont'd)

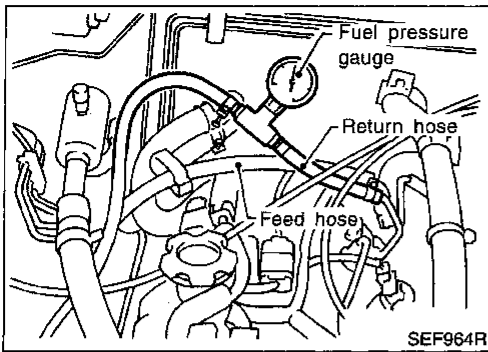

3. Install pressure gauge between fuel filter and fuel tube.
4. Start engine and check for fuel leakage.
5. Read the indication of fuel pressure gauge.

#### At idling:

##### With vacuum hose connected

Approximately 235 kPa (2.4 kg/cm<sup>2</sup>, 34 psi)

##### With vacuum hose disconnected

Approximately 294 kPa (3.0 kg/cm<sup>2</sup>, 43 psi)

If results are unsatisfactory, perform Fuel Pressure Regulator Check.

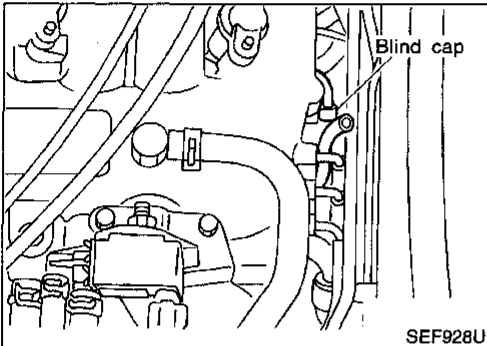

### Fuel Pressure Regulator Check

NEEC0387

1. Stop engine and disconnect fuel pressure regulator vacuum hose from intake manifold.
2. Plug intake manifold with a blind cap.
3. Connect variable vacuum source to fuel pressure regulator.

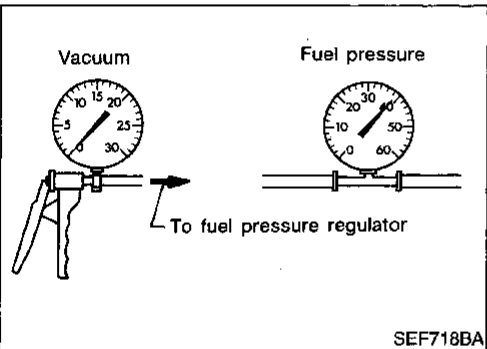

4. Start engine and read indication of fuel pressure gauge as vacuum is changed.

**Fuel pressure should decrease as vacuum increases. If results are unsatisfactory, replace fuel pressure regulator.**

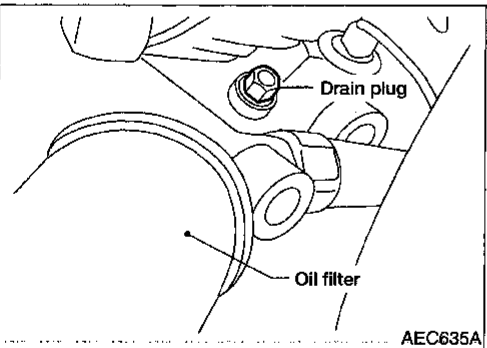

### Injector

#### REMOVAL AND INSTALLATION

NEEC0026

1. Release fuel pressure to zero. Refer to EC-31.
2. Drain coolant by removing drain plugs from both sides of cylinder block.
3. Separate ASCD and accelerator control wire from intake manifold collector.
4. Remove intake manifold collector from engine. The following parts should be disconnected or removed.
  - a. Harness connectors for
    - IACV-AAC valve
    - IACV-FICD solenoid valve
    - Throttle position sensor and closed throttle position switch assembly
    - EGRC-solenoid valve
    - EGR temperature sensor
    - Ground harness
  - b. PCV valve ventilation hoses
  - c. Vacuum hoses for
    - Brake booster
    - EGRC-solenoid valve

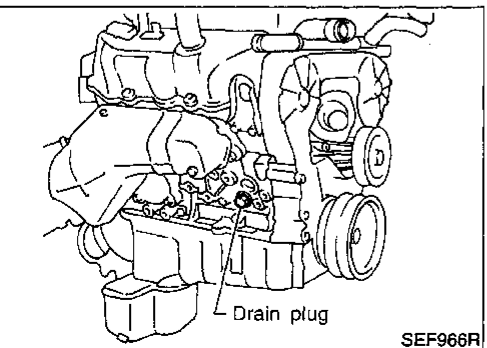

- Fuel pressure regulator
- EGRC-BPT valve
- d. Air hoses from
  - Air duct
  - IACV-AAC valve
- e. Water hoses for
  - Throttle body
  - Air relief plug
- f. EVAP canister purge hose
- g. EGR flare tube
- 5. Remove injector fuel tube assembly.  
The following parts should be disconnected or removed.
  - Vacuum hose for fuel pressure regulator
  - Fuel feed and return hose
  - All injectors harness connectors
  - **Push injector tail piece.**
  - **Do not pull on connector.**
  - **Do not extract injector by pinching.**

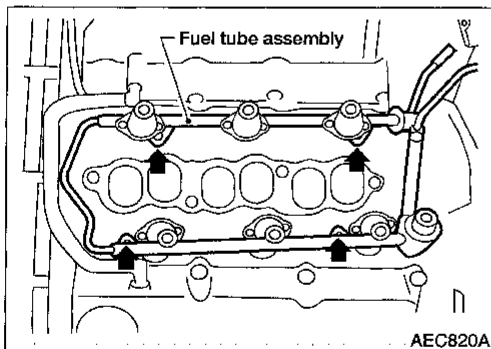
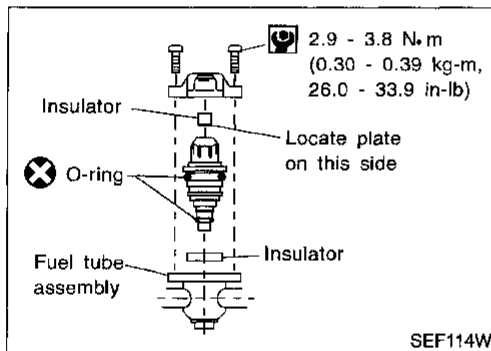

6. Push out any malfunctioning injector from injector fuel tube.
7. Replace or clean injector as necessary.
  - **Always replace O-rings with new ones.**
  - **Lubricate O-rings with engine oil.**
8. Install injector to injector fuel tube assembly.

9. Install injectors with fuel tube assembly to intake manifold.  
**Tighten in numerical order shown in the figure.**
  - a. First, tighten all bolts to 4.9 to 6.0 N·m (0.5 to 0.61 kg-m, 3.6 to 4.4 ft-lb).
  - b. Then, tighten all bolts to 10.8 to 14.7 N·m (1.1 to 1.5 kg-m, 8 to 11 ft-lb).
10. Reinstall any part removed in reverse order of removal.

**CAUTION:**

After properly connecting fuel hose to injector and fuel tube, check connection for fuel leakage.

☆ MONITOR	☆ NO FAIL	<input type="checkbox"/>
COOLAN TEMP/S	25°C	
<b>RECORD</b>		

SEF052R

## Fast Idle Cam (FIC) INSPECTION AND ADJUSTMENT

**With CONSULT**

1. Turn ignition switch "ON".
2. See "COOLAN TEMP/S" in "DATA MONITOR" mode with CONSULT.
3. When engine coolant temperature is 20 to 30°C (68 to 86°F), make sure that the center of mark **A** is aligned with mark **B** as shown in the figure.

NEEC0026

NEEC0026S01

GI  
MA  
EM  
LC  
EC  
FE  
CL  
MT  
AT  
TF  
PD  
FA  
RA  
BR  
ST  
RS  
BT  
HA  
EL  
IDX

# BASIC SERVICE PROCEDURE

## Fast Idle Cam (FIC) (Cont'd)

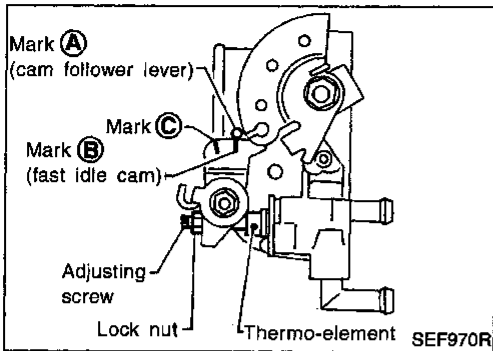

- If NG, adjust by turning adjusting screw.

### Lock nut:

☞ : 0.98 - 1.96 N·m (10 - 20 kg·cm, 8.7 - 17.4 in·lb)

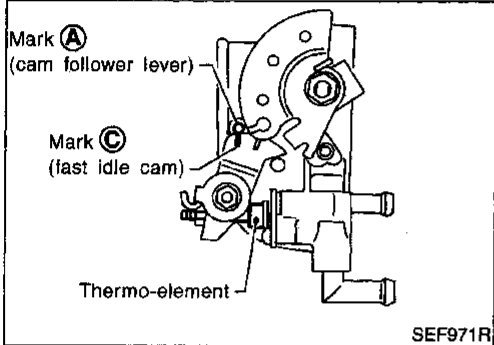

4. Start engine and warm it up.
5. When engine coolant temperature is 75 to 85°C (167 to 185°F), check the following.
  - The center of mark **A** is aligned with mark **C**.
  - The cam follower lever's roller is not touching the fast idle cam.
  - If NG, replace thermo-element and perform the above inspection and adjustment again.

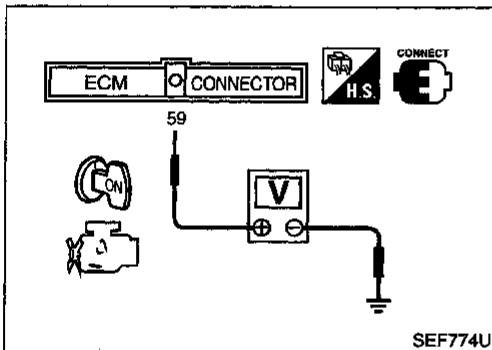

### ⊗ Without CONSULT

NEEC0026S02

1. Turn ignition switch "ON".
2. Check voltage between ECM terminal 59 (Engine coolant temperature sensor signal) and ground.
3. When the voltage is between 3.12 to 3.52V, make sure that the center of mark **A** is aligned with mark **B** as shown in the figure.

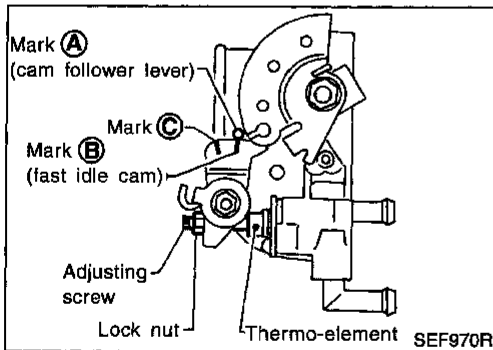

- If NG, adjust by turning adjusting screw.

### Lock nut:

☞ : 0.98 - 1.96 N·m (10 - 20 kg·cm, 8.7 - 17.4 in·lb)

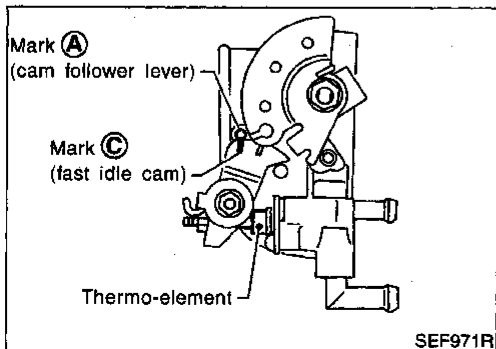

4. Start engine and warm it up.
5. When the voltage is between 1.10 to 1.36V, check the following.
  - The center of mark **A** is aligned with mark **C**.
  - The cam follower lever's roller is not touching the fast idle cam.
  - If NG, replace thermo-element and perform the above inspection and adjustment again.



# BASIC SERVICE PROCEDURE

*Idle Speed/Ignition Timing/Idle Mixture Ratio Adjustment*

## Idle Speed/Ignition Timing/Idle Mixture Ratio Adjustment

NEEC0027

NEEC0027S01

### PREPARATION

- 1) Make sure that the following parts are in good order.
  - Battery
  - Ignition system
  - Engine oil and coolant levels
  - Fuses
  - ECM harness connector
  - Vacuum hoses
  - Air intake system  
(Oil filler cap, oil level gauge, etc.)
  - Fuel pressure
  - Engine compression
  - EGR valve operation
  - Throttle valve
  - Evaporative emission system
- 2) On air conditioner equipped models, checks should be carried out while the air conditioner is "OFF".
- 3) On automatic transmission equipped models, when checking idle rpm, ignition timing and mixture ratio, checks should be carried out while shift lever is in "N" position.
- 4) When measuring "CO" percentage, insert probe more than 40 cm (15.7 in) into tail pipe.
- 5) Turn off headlamps, heater blower, rear defogger.
- 6) Keep front wheels pointed straight ahead.
- 7) Make the check after the cooling fan has stopped.

GI

MA

EM

LC

**EC**

FE

CL

MT

AT

TF

PD

FA

RA

BR

ST

RS

BT

HA

EL

IDX

# BASIC SERVICE PROCEDURE

Idle Speed/Ignition Timing/Idle Mixture Ratio Adjustment (Cont'd)

## Overall Inspection Sequence

NEEC002760101

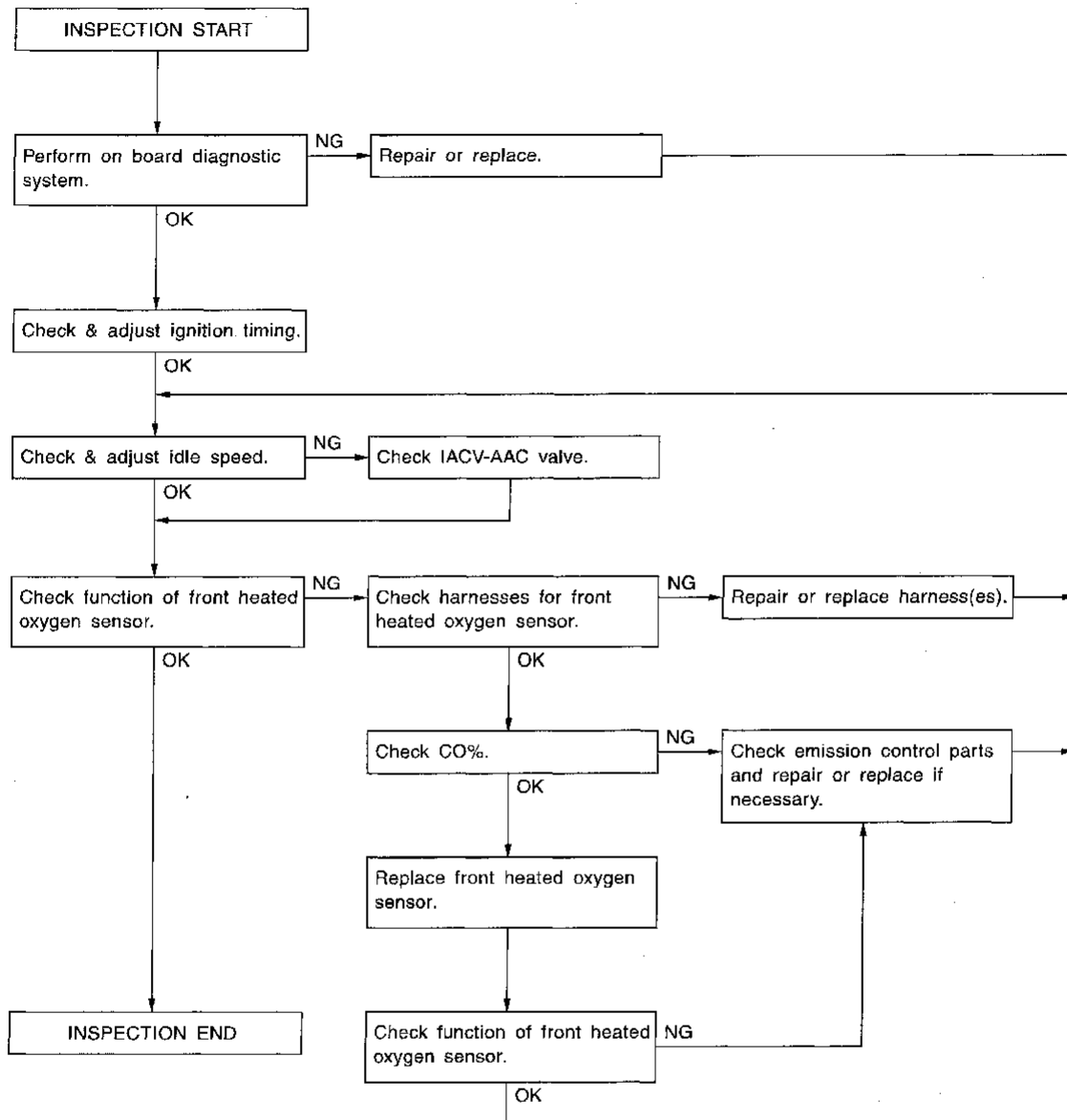

SEF117W

### NOTE:





If a vehicle contains a part which is operating outside of design specifications with no MIL illumination, the part shall not be replaced prior to emission testing unless it is determined that the part has been tampered with or abused in such a way that the diagnostic system cannot reasonably be expected to detect the resulting malfunction.

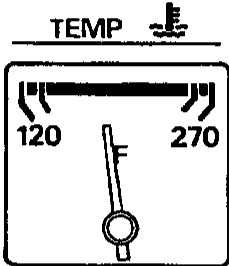

# BASIC SERVICE PROCEDURE

Idle Speed/Ignition Timing/Idle Mixture Ratio Adjustment (Cont'd)

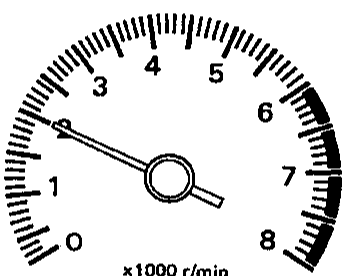
## INSPECTION PROCEDURE

-NEEC0027502

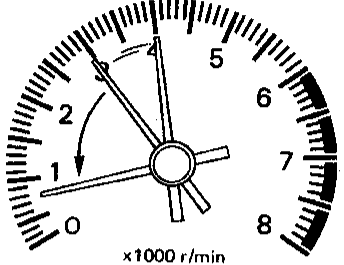
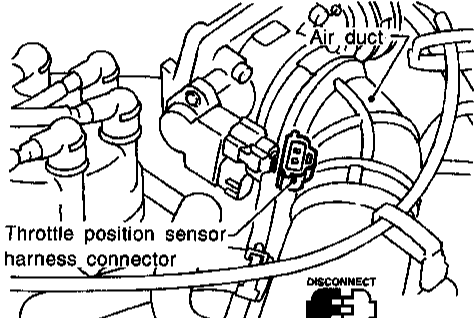
<b>1</b>	<b>INSPECTION START</b>
<p>1. Visually check the following:</p> <ul style="list-style-type: none"> <li>• Air cleaner clogging</li> <li>• Hoses and ducts for leaks</li> <li>• EGR valve operation</li> <li>• Electrical connectors</li> <li>• Gasket</li> <li>• Throttle valve and throttle position sensor operation</li> </ul> <p>2. Start engine and warm it up until engine coolant temperature indicator points to the middle of gauge. Ensure engine stays below 1,000 rpm.</p>	
 <p>TEMP </p>	
SEF976U	
<p>3. Open engine hood and run engine at about 2,000 rpm for about 2 minutes under no-load.</p>	
 <p>x1000 r/min</p>	
SEF977U	
<p>4. Perform diagnostic test mode II (Self-diagnostic results). Refer to EC-59.</p>	
	
SEF217U	
<b>OK or NG</b>	
OK	▶ GO TO 2.
NG	▶ 1. Repair or replace components as necessary. 2. GO TO 2.

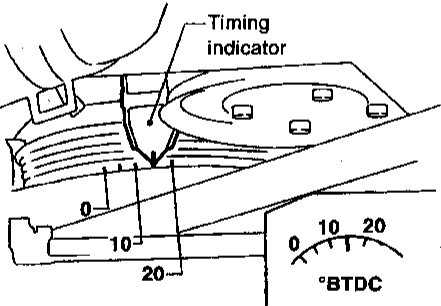
<b>2</b>	<b>CHECK IGNITION TIMING</b>
<p>1. Run engine at about 2,000 rpm for about 2 minutes under no-load.</p> <p>2. Rev engine (2,000 to 3,000 rpm) two or three times under no-load, then run engine at idle speed.</p>	
 <p>x1000 r/min</p>	
SEF978U	
<p>3. Turn off engine and disconnect throttle position sensor harness connector.</p>	
 <p>Air duct</p> <p>Throttle position sensor harness connector</p> <p>DISCONNECT </p>	
SEF975R	
<p>4. Start and rev engine (2,000 - 3,000 rpm) two or three times under no-load, then run at idle speed.</p> <p>5. Check ignition timing with a timing light.</p>	
 <p>Timing indicator</p> <p>0 10 20</p> <p>°BTDC</p>	
<p>15°±2° BTDC (in "P" or "N" position)</p> <p><b>OK or NG</b></p>	
OK	▶ GO TO 4.
NG	▶ GO TO 3.

GI  
MA  
EM  
LC  
EC  
FE  
CL  
MT  
AT  
TF  
PD  
FA  
RA  
BR  
ST  
RS  
BT  
HA  
EL  
IDX

# BASIC SERVICE PROCEDURE

Idle Speed/Ignition Timing/Idle Mixture Ratio Adjustment (Cont'd)

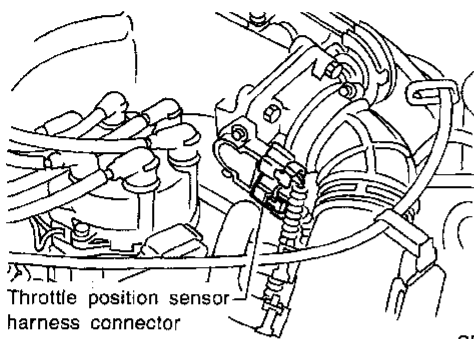
<b>3</b>	<b>ADJUST IGNITION TIMING</b>
<ol style="list-style-type: none"> <li>Adjust ignition timing by turning distributor after loosening securing bolts.</li> <li>Turn off engine and connect throttle position sensor harness connector to throttle position sensor.</li> </ol>	
 <p>Throttle position sensor harness connector</p>	
SEF972R	
▶ GO TO 2.	

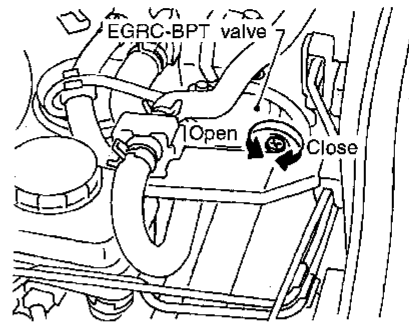
<b>5</b>	<b>ADJUST BASE IDLE SPEED</b>
<ol style="list-style-type: none"> <li>Rev engine (2,000 to 3,000 rpm) 2 or 3 times under no-load then run engine at idle speed.</li> <li>Adjust idle speed by turning idle speed adjusting screw.</li> </ol>	
	
<b>700±50 rpm (in "P" or "N" position)</b>	
SEF973R	
▶ GO TO 6.	

<b>4</b>	<b>CHECK BASE IDLE SPEED</b>									
<p><b>With CONSULT</b></p> <ol style="list-style-type: none"> <li>Read idle speed in "DATA MONITOR" mode with CONSULT.</li> </ol>										
<table border="1" style="width: 100%;"> <tr> <td>☆ MONITOR</td> <td>☆ NO FAIL</td> <td><input type="checkbox"/></td> </tr> <tr> <td>CMPS•RPM(REF)</td> <td>700 rpm</td> <td></td> </tr> <tr> <td colspan="3" style="text-align: center;"><b>RECORD</b></td> </tr> </table>		☆ MONITOR	☆ NO FAIL	<input type="checkbox"/>	CMPS•RPM(REF)	700 rpm		<b>RECORD</b>		
☆ MONITOR	☆ NO FAIL	<input type="checkbox"/>								
CMPS•RPM(REF)	700 rpm									
<b>RECORD</b>										
700±50 rpm (in "P" or "N" position)										
SEF356V										
<p><b>Without CONSULT</b></p> <ol style="list-style-type: none"> <li>Check idle speed.</li> </ol> <p style="text-align: center;"><b>700±50 rpm (in "P" or "N" position)</b></p> <p style="text-align: center;"><b>OK or NG</b></p>										
OK	▶ GO TO 6.									
NG	▶ GO TO 5.									

<b>6</b>	<b>CHECK TARGET IDLE SPEED</b>									
<p><b>With CONSULT</b></p> <ol style="list-style-type: none"> <li>Turn off engine and connect throttle position sensor harness connector.</li> <li>Start and rev engine (2,000 to 3,000 rpm) 2 or 3 times under no-load then run at idle speed.</li> <li>Read idle speed in "DATA MONITOR" mode with CONSULT.</li> </ol>										
<table border="1" style="width: 100%;"> <tr> <td>☆ MONITOR</td> <td>☆ NO FAIL</td> <td><input type="checkbox"/></td> </tr> <tr> <td>CMPS•RPM(REF)</td> <td>750 rpm</td> <td></td> </tr> <tr> <td colspan="3" style="text-align: center;"><b>RECORD</b></td> </tr> </table>		☆ MONITOR	☆ NO FAIL	<input type="checkbox"/>	CMPS•RPM(REF)	750 rpm		<b>RECORD</b>		
☆ MONITOR	☆ NO FAIL	<input type="checkbox"/>								
CMPS•RPM(REF)	750 rpm									
<b>RECORD</b>										
750±50 rpm (in "P" or "N" position)										
SEF357V										
<p><b>Without CONSULT</b></p> <ol style="list-style-type: none"> <li>Turn off engine and connect throttle position sensor harness connector.</li> <li>Start and rev engine (2,000 to 3,000 rpm) 2 or 3 times under no-load then run at idle speed.</li> <li>Check idle speed.</li> </ol> <p style="text-align: center;"><b>750±50 rpm (in "P" or "N" position)</b></p> <p style="text-align: center;"><b>OK or NG</b></p>										
OK (With CONSULT)	▶ GO TO 8.									
OK (Without CONSULT)	▶ GO TO 9.									
NG	▶ GO TO 7.									

# BASIC SERVICE PROCEDURE

Idle Speed/Ignition Timing/Idle Mixture Ratio Adjustment (Cont'd)

<b>7</b>	<b>DETECT MALFUNCTIONING PART</b>	
<p>Check the following.</p> <ol style="list-style-type: none"> <li>1. Check IACV-AAC valve and replace if necessary. Refer to EC-335.</li> <li>2. Check IACV-AAC valve harness and repair if necessary. Refer to EC-335.</li> <li>3. Check ECM function by substituting another known good ECM. (ECM may be the cause of a problem, but this is rarely the case.)</li> </ol>		
With CONSULT	▶	GO TO 8.
Without CONSULT	▶	GO TO 9.

<b>8</b>	<b>CHECK FRONT HEATED OXYGEN SENSOR LH SIGNAL</b>													
<p>Ⓜ <b>With CONSULT</b></p> <ol style="list-style-type: none"> <li>1. Run engine at about 2,000 rpm for about 2 minutes under no-load.</li> <li>2. See "FR O2 MNTR-B2" in "DATA MONITOR" mode.</li> <li>3. Running engine at 2,000 rpm under no-load (engine is warmed up to normal operating temperature.), check that the monitor fluctuates between "LEAN" and "RICH" more than 5 times during 10 seconds.</li> </ol>														
<table border="1" style="width: 100%;"> <tr> <td>☆ MONITOR</td> <td>☆ NO FAIL</td> <td><input type="checkbox"/></td> </tr> <tr> <td>CMPS•RPM(REF)</td> <td>2087rpm</td> <td></td> </tr> <tr> <td>FR O2 MNTR-B1</td> <td>LEAN</td> <td></td> </tr> <tr> <td>FR O2 MNTR-B2</td> <td>RICH</td> <td></td> </tr> </table>			☆ MONITOR	☆ NO FAIL	<input type="checkbox"/>	CMPS•RPM(REF)	2087rpm		FR O2 MNTR-B1	LEAN		FR O2 MNTR-B2	RICH	
☆ MONITOR	☆ NO FAIL	<input type="checkbox"/>												
CMPS•RPM(REF)	2087rpm													
FR O2 MNTR-B1	LEAN													
FR O2 MNTR-B2	RICH													
<b>RECORD</b>														
<p>1 time: RICH → LEAN → RICH                  2 times: RICH → LEAN → RICH → LEAN → RICH</p>														
<b>OK or NG</b>														
OK	▶	GO TO 12.												
NG (Monitor does not fluctuate.)	▶	GO TO 17.												
NG (Monitor fluctuates less than 5 times.)	▶	<ol style="list-style-type: none"> <li>1. Replace front heated oxygen sensor LH.</li> <li>2. GO TO 10.</li> </ol>												

SEF358V

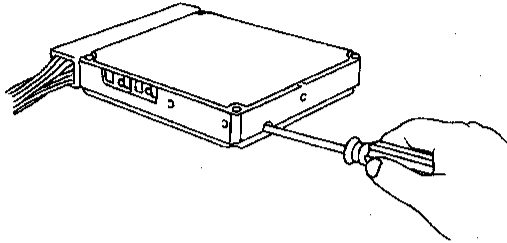
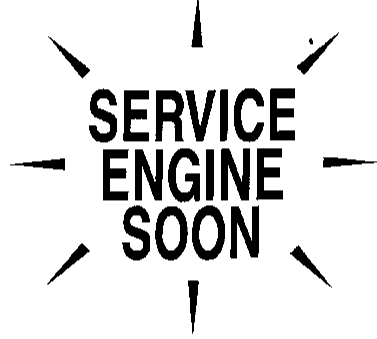
<b>9</b>	<b>CHECK FRONT HEATED OXYGEN SENSOR LH SIGNAL</b>	
<p>⊗ <b>Without CONSULT</b></p> <ol style="list-style-type: none"> <li>1. Run engine at about 2,000 rpm for about 2 minutes under no-load.</li> <li>2. Set "Left bank front heated oxygen sensor monitor" in the Diagnostic Test Mode II. Refer to EC-59.</li> </ol>		
		
SEF979U		
<ol style="list-style-type: none"> <li>3. Make sure that MIL goes on more than 5 times during 10 seconds at 2,000 rpm.</li> </ol>		
		
SEF217U		
<b>OK or NG</b>		
OK	▶	GO TO 12.
NG (MIL does not blink.)	▶	GO TO 17.
NG (MIL blinks less than 5 times.)	▶	<ol style="list-style-type: none"> <li>1. Replace front heated oxygen sensor LH.</li> <li>2. GO TO 10.</li> </ol>

GI  
MA  
EM  
LC  
EC  
FE  
CL  
MT  
AT  
TF  
PD  
FA  
RA  
BR  
ST  
RS  
BT  
HA  
EL  
IDX

# BASIC SERVICE PROCEDURE

*Idle Speed/ignition Timing/Idle Mixture Ratio Adjustment (Cont'd)*

<b>10</b>	<b>CHECK FRONT HEATED OXYGEN SENSOR LH SIGNAL</b>
<p><b>☐ With CONSULT</b></p> <ol style="list-style-type: none"> <li>1. Warm engine to normal operating temperature.</li> <li>2. Run engine at approx. 2000 rpm for approx. 2 minutes under no-load.</li> <li>3. See "FR O2 MNTR-B2" in "DATA MONITOR" mode.</li> <li>4. Running engine at 2,000 rpm under no-load (engine is warmed up to normal operating temperature.), check that the monitor fluctuates between "LEAN" and "RICH" more than 5 times during 10 seconds.  <b>1 time: RICH → LEAN → RICH</b>  <b>2 times: RICH → LEAN → RICH → LEAN → RICH</b></li> </ol>	
<p><b>⊗ Without CONSULT</b></p> <ol style="list-style-type: none"> <li>1. Warm engine to normal operating temperature.</li> <li>2. Run engine at approx. 2000 rpm for approx. 2 minutes under no-load.</li> <li>3. Set "Left bank front heated oxygen sensor monitor" in the Diagnostic Test Mode II. Refer to EC-59.</li> <li>4. Make sure that MIL goes on more than 5 times during 10 seconds at 2,000 rpm.</li> </ol>	
<b>OK or NG</b>	
OK (With CONSULT) ▶	GO TO 12.
OK (Without CONSULT) ▶	GO TO 13.
NG ▶	GO TO 11.

<b>11</b>	<b>DETECT MALFUNCTIONING PART</b>
<p>Check the following.</p> <ol style="list-style-type: none"> <li>1. Check fuel pressure regulator. Refer to EC-32.</li> <li>2. Check mass air flow sensor and its circuit. Refer to EC-121.</li> <li>3. Check injector and its circuit. Refer to EC-460. Clean or replace if necessary.</li> <li>4. Check engine coolant temperature sensor and its circuit. Refer to EC-161.</li> <li>5. Check ECM function by substituting another known good ECM. (ECM may be the cause of a problem, but this is rarely the case.)</li> </ol>	
▶ GO TO 2.	

<b>12</b>	<b>CHECK FRONT HEATED OXYGEN SENSOR RH SIGNAL</b>								
<p><b>☐ With CONSULT</b></p> <ol style="list-style-type: none"> <li>1. See "FR O2 MNTR-B1" in "DATA MONITOR" mode.</li> <li>2. Maintaining engine at 2,000 rpm under no-load (engine is warmed up to normal operating temperature.), check that the monitor fluctuates between "LEAN" and "RICH" more than 5 times during 10 seconds.</li> </ol>									
<table border="1" style="width: 100%; border-collapse: collapse;"> <tr> <td style="text-align: center;">☆ MONITOR</td> <td style="text-align: center;">☆ NO FAIL <input type="checkbox"/></td> </tr> <tr> <td>CMPS•RPM(REF)</td> <td>2087rpm</td> </tr> <tr> <td>FR O2 MNTR-B1</td> <td>LEAN</td> </tr> <tr> <td>FR O2 MNTR-B2</td> <td>RICH</td> </tr> </table>		☆ MONITOR	☆ NO FAIL <input type="checkbox"/>	CMPS•RPM(REF)	2087rpm	FR O2 MNTR-B1	LEAN	FR O2 MNTR-B2	RICH
☆ MONITOR	☆ NO FAIL <input type="checkbox"/>								
CMPS•RPM(REF)	2087rpm								
FR O2 MNTR-B1	LEAN								
FR O2 MNTR-B2	RICH								
<b>RECORD</b>									
SEF358V									
<p><b>1 time: RICH → LEAN → RICH</b>  <b>2 times: RICH → LEAN → RICH → LEAN → RICH</b></p>									
<b>OK or NG</b>									
OK ▶	<b>INSPECTION END</b>								
NG (Monitor does not fluctuate.) ▶	GO TO 16.								
NG (Monitor fluctuates less than 5 times.) ▶	<ol style="list-style-type: none"> <li>1. Replace front heated oxygen sensor RH.</li> <li>2. GO TO 14.</li> </ol>								

# BASIC SERVICE PROCEDURE

Idle Speed/Ignition Timing/Idle Mixture Ratio Adjustment (Cont'd)

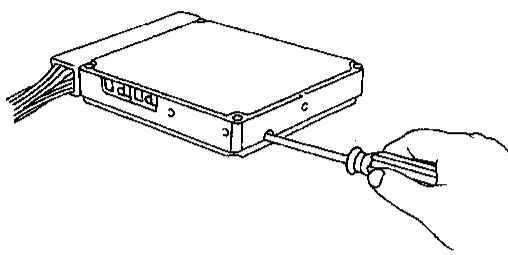
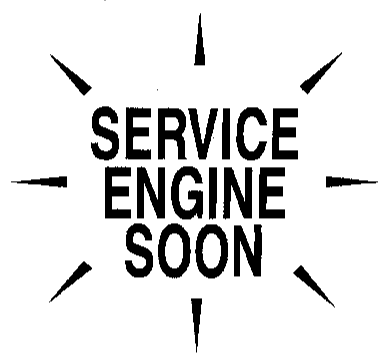
<b>13</b>	<b>CHECK FRONT HEATED OXYGEN SENSOR RH SIGNAL</b>	
<p><b>⊗ Without CONSULT</b></p> <p>1. Set "Right bank front heated oxygen sensor monitor" in the Diagnostic Test Mode II. Refer to EC-59.</p>		
		
SEF979U		
<p>2. Make sure that MIL goes on more than 5 times during 10 seconds at 2,000 rpm.</p>		
		
SEF217U		
OK or NG		
OK	▶	INSPECTION END
NG (MIL does not blink.)	▶	GO TO 16.
NG (MIL blinks less than 5 times.)	▶	1. Replace front heated oxygen sensor RH. 2. GO TO 14.

<b>14</b>	<b>CHECK FRONT HEATED OXYGEN SENSOR RH SIGNAL</b>	
<p><b>Ⓜ With CONSULT</b></p> <p>1. Warm engine to normal operating temperature.</p> <p>2. Run engine at approx. 2000 rpm for approx. 2 minutes under no-load.</p> <p>3. See "FR O2 MNTR-B1" in "DATA MONITOR" mode.</p> <p>4. Maintaining engine at 2,000 rpm under no-load (engine is warmed up to normal operating temperature.), check that the monitor fluctuates between "LEAN" and "RICH" more than 5 times during 10 seconds.</p> <p style="margin-left: 20px;"><b>1 time: RICH → LEAN → RICH</b></p> <p style="margin-left: 20px;"><b>2 times: RICH → LEAN → RICH → LEAN → RICH</b></p>		
<p><b>⊗ Without CONSULT</b></p> <p>1. Warm engine to normal operating temperature.</p> <p>2. Run engine at approx. 2000 rpm for approx. 2 minutes under no-load.</p> <p>3. Set "Right bank front heated oxygen sensor monitor" in the Diagnostic Test Mode II. Refer to EC-59.</p> <p>4. Make sure that MIL goes on more than 5 times during 10 seconds at 2,000 rpm.</p>		
OK or NG		
OK	▶	INSPECTION END
NG	▶	GO TO 15.

<b>15</b>	<b>DETECT MALFUNCTIONING PART</b>
<p>Check the following.</p> <p>1. Check fuel pressure regulator. Refer to EC-32.</p> <p>2. Check mass air flow sensor and its circuit. Refer to EC-121.</p> <p>3. Check injector and its circuit. Refer to EC-460. Clean or replace if necessary.</p> <p>4. Check engine coolant temperature sensor and its circuit. Refer to EC-161.</p> <p>5. Check ECM function by substituting another known good ECM. (ECM may be the cause of a problem, but this is rarely the case.)</p>	
▶	
GO TO 2.	

GI  
 MA  
 EM  
 LC  
**EC**  
 FE  
 CL  
 MT  
 AT  
 TF  
 PD  
 FA  
 RA  
 BR  
 ST  
 RS  
 BT  
 HA  
 EL  
 IDX

# BASIC SERVICE PROCEDURE

Idle Speed/Ignition Timing/Idle Mixture Ratio Adjustment (Cont'd)

<b>16</b>	<b>CHECK FRONT HEATED OXYGEN SENSOR RH HARNESS</b>
<ol style="list-style-type: none"> <li>1. Turn off engine and disconnect battery ground cable.</li> <li>2. Disconnect ECM harness connector.</li> <li>3. Disconnect front heated oxygen sensor RH harness connector.</li> <li>4. Check harness continuity between ECM terminal 50 and front heated oxygen sensor RH harness connector.</li> </ol>	
<p>Continuity should exist.</p> <p>SEF980U</p>	
<b>OK or NG</b>	
OK	▶ 1. Connect ECM harness connector. 2. GO TO 18.
NG	▶ 1. Repair or replace harness. 2. GO TO 8. (With CONSULT) GO TO 9. (Without CONSULT)

<b>17</b>	<b>CHECK FRONT HEATED OXYGEN SENSOR LH HARNESS</b>
<ol style="list-style-type: none"> <li>1. Turn off engine and disconnect battery ground cable.</li> <li>2. Disconnect ECM harness connector.</li> <li>3. Disconnect front heated oxygen sensor LH harness connector.</li> <li>4. Check harness continuity between ECM terminal 51 and front heated oxygen sensor LH harness connector.</li> </ol>	
<p>Continuity should exist.</p> <p>SEF981U</p>	
<b>OK or NG</b>	
OK	▶ 1. Connect ECM harness connector. 2. GO TO 18.
NG	▶ 1. Repair or replace harness. 2. GO TO 8. (With CONSULT) GO TO 9. (Without CONSULT)

<b>18</b>	<b>PREPARATION FOR "CO" % CHECK</b>
<p> <b>With CONSULT</b></p> <ol style="list-style-type: none"> <li>1. Select "COOLANT TEMP" in "ACTIVE TEST" mode.</li> <li>2. Set "COOLANT TEMP" to 5°C (41°F) by touching "DWN" and "Qd".</li> </ol>	
SEF359V	
<p> <b>Without CONSULT</b></p> <ol style="list-style-type: none"> <li>1. Disconnect engine coolant temperature sensor harness connector.</li> <li>2. Connect a resistor (4.4 kΩ) between terminals of engine coolant temperature sensor harness connector.</li> </ol>	
SEF982U	
▶ GO TO 19.	



# BASIC SERVICE PROCEDURE

Idle Speed/Ignition Timing/Idle Mixture Ratio Adjustment (Cont'd)

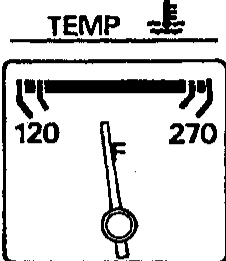
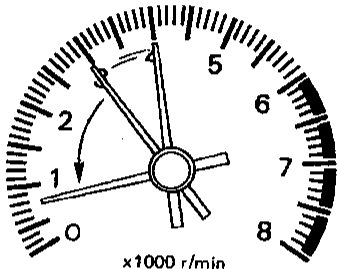
<b>19</b>	<b>CHECK "CO" %</b>
<p>1. Start engine and warm it up until engine coolant temperature indicator points to the middle of gauge.</p>	
	
SEF976U	
<p>2. Rev engine (2,000 to 3,000 rpm) two or three times under no-load, then run engine at idle speed.</p>	
	
SEF978U	
<p>3. Check "CO" %. Idle CO: 0.2 - 8%</p>	
<p>4. <input checked="" type="checkbox"/> Without CONSULT After checking CO%,</p>	
<p>a. Disconnect the resistor from terminals of engine coolant temperature sensor.</p>	
<p>b. Connect engine coolant temperature sensor harness connector to engine coolant temperature sensor.</p>	
<b>OK or NG</b>	
OK	▶
<p>1. Replace front heated oxygen sensor LH. 2. GO TO 10.</p>	
NG	▶
<p>GO TO 20.</p>	

<b>20</b>	<b>DETECT MALFUNCTIONING PART</b>
<p>Check the following.</p>	
<p>1. Connect front heated oxygen sensor harness connectors to front heated oxygen sensors.</p>	
<p>2. Check fuel pressure regulator. Refer to EC-32.</p>	
<p>3. Check mass air flow sensor and its circuit. Refer to EC-121.</p>	
<p>4. Check injector and its circuit. Refer to EC-460. Clean or replace if necessary.</p>	
<p>5. Check engine coolant temperature sensor and its circuit. Refer to EC-161.</p>	
<p>6. Check ECM function by substituting another known good ECM. (ECM may be the cause of a problem, but this is rarely the case.)</p>	
▶	GO TO 2.

GI  
MA  
EM  
LC  
EC  
FE  
CL  
MT  
AT  
TF  
PD  
FA  
RA  
BR  
ST  
RS  
BT  
HA  
EL  
IDX

# ON BOARD DIAGNOSTIC SYSTEM DESCRIPTION

## Introduction

### Introduction

NEEC0028

The ECM has an on board diagnostic system, which detects malfunctions related to engine sensors or actuators. The ECM also records various emission-related diagnostic information including:

Emission-related diagnostic information	SAE Mode
Diagnostic Trouble Code (DTC)	Mode 3 of SAE J1979
Freeze Frame data	Mode 2 of SAE J1979
System Readiness Test (SRT) code	Mode 1 of SAE J1979
1st Trip Diagnostic Trouble Code (1st Trip DTC)	Mode 7 of SAE J1979
1st Trip Freeze Frame data	
Test values and Test limits	Mode 6 of SAE J1979

The above information can be checked using procedures listed in the table below.

X: Applicable —: Not applicable

	DTC	1st trip DTC	Freeze Frame data	1st trip Freeze Frame data	SRT code	Test value
ECM*3	X	X*1	—	—	—	—
CONSULT	X	X	X	X	X	—
GST	X	X*2	X	—	X	X

\*1: When DTC and 1st trip DTC simultaneously appear on the display, they cannot be clearly distinguished from each other.

\*2: 1st trip DTCs for self-diagnoses concerning SRT items cannot be shown on the GST display.

\*3: In diagnostic test mode II (Self-diagnostic results)

The malfunction indicator lamp (MIL) on the instrument panel lights up when the same malfunction is detected in two consecutive trips (Two trip detection logic), or when the ECM enters fail-safe mode. (Refer to EC-96.)

### Two Trip Detection Logic

NEEC0029

When a malfunction is detected for the first time, 1st trip DTC and 1st trip Freeze Frame data are stored in the ECM memory. The MIL will not light up at this stage. <1st trip>

If the same malfunction is detected again during the next drive, the DTC and Freeze Frame data are stored in the ECM memory, and the MIL lights up. The MIL lights up at the same time when the DTC is stored. <2nd trip> The "trip" in the "Two Trip Detection Logic" means a driving mode in which self-diagnosis is performed during vehicle operation. Specific on board diagnostic items will cause the ECM to light up or blink the MIL, and store DTC and Freeze Frame data, even in the 1st trip, as shown below.

X: Applicable —: Not applicable

Items	MIL			DTC		1st trip DTC	
	1st trip		2nd trip lighting up	1st trip displaying	2nd trip displaying	1st trip displaying	2nd trip displaying
	Blinking	Lighting up					
Misfire (Possible three way catalyst damage) — DTC: P0300 - P0306 (0701, 0603 - 0608) is being detected	X	—	—	X	—	X	—
Misfire (Possible three way catalyst damage) — DTC: P0300 - P0306 (0701, 0603 - 0608) has been detected	—	X	—	X	—	X	—
Closed loop control — DTC: P1148 (0307)	—	X	—	X	—	X	—
Fail-safe items (Refer to EC-96.)	—	X	—	X*1	—	X*1	—
Except above	—	—	X	—	X	X	X

\*1: Except "ECM"

## Emission-related Diagnostic Information

NEEC00030

### DTC AND 1ST TRIP DTC

NEEC00030S01

The 1st trip DTC (whose number is the same as the DTC number) is displayed for the latest self-diagnostic result obtained. If the ECM memory was cleared previously, and the 1st trip DTC did not reoccur, the 1st trip DTC will not be displayed.

If a malfunction is detected during the 1st trip, the 1st trip DTC is stored in the ECM memory. The MIL will not light up (two trip detection logic). If the same malfunction is not detected in the 2nd trip (meeting the required driving pattern), the 1st trip DTC is cleared from the ECM memory. If the same malfunction is detected in the 2nd trip, both the 1st trip DTC and DTC are stored in the ECM memory and the MIL lights up. In other words, the DTC is stored in the ECM memory and the MIL lights up when the same malfunction occurs in two consecutive trips. If a 1st trip DTC is stored and a non-diagnostic operation is performed between the 1st and 2nd trips, only the 1st trip DTC will continue to be stored. For malfunctions that blink or light up the MIL during the 1st trip, the DTC and 1st trip DTC are stored in the ECM memory.

Procedures for clearing the DTC and the 1st trip DTC from the ECM memory are described in "HOW TO ERASE EMISSION-RELATED DIAGNOSTIC INFORMATION", EC-55.

For malfunctions in which 1st trip DTCs are displayed, refer to EC-53. These items are required by legal regulations to continuously monitor the system/component. In addition, the items monitored non-continuously are also displayed on CONSULT.

1st trip DTC is specified in Mode 7 of SAE J1979. 1st trip DTC detection occurs without lighting up the MIL and therefore does not warn the driver of a problem. However, 1st trip DTC detection will not prevent the vehicle from being tested, for example during Inspection/Maintenance (I/M) tests.

When a 1st trip DTC is detected, check, print out or write down and erase (1st trip) DTC and Freeze Frame data as specified in "Work Flow" procedure Step II, refer to EC-84. Then perform "DTC Confirmation Procedure" or "Overall Function Check" to try to duplicate the problem. If the malfunction is duplicated, the item requires repair.

### How to Read DTC and 1st Trip DTC

NEEC00030S101

DTC and 1st trip DTC can be read by the following methods.

1)  **No Tools**

The number of blinks of the MIL in the Diagnostic Test Mode II (Self-Diagnostic Results) Examples: 0101, 0201, 1003, 1104, etc.

These DTCs are controlled by NISSAN.

2)  **With CONSULT**

 **With GST**

CONSULT or GST (Generic Scan Tool) Examples: P0340, P1320, P0705, P0750, etc.

These DTCs are prescribed by SAE J2012.

(CONSULT also displays the malfunctioning component or system.)

- **1st trip DTC No. is the same as DTC No.**
- **Output of a DTC indicates a malfunction. However, Mode II and GST do not indicate whether the malfunction is still occurring or has occurred in the past and has returned to normal. CONSULT can identify malfunction status as shown below. Therefore, using CONSULT (if available) is recommended.**

A sample of CONSULT display for DTC and 1st trip DTC is shown below. DTC or 1st trip DTC of a malfunction is displayed in SELF-DIAGNOSTIC RESULTS mode of CONSULT. Time data indicates how many times the vehicle was driven after the last detection of a DTC.

If the DTC is being detected currently, the time data will be "0".

If a 1st trip DTC is stored in the ECM, the time data will be "[1t]".

	<div style="border: 1px solid black; padding: 5px;"> <p style="text-align: center;">■ SELF-DIAG RESULTS ■ <input type="checkbox"/></p> <p>FAILURE DETECTED    TIME</p> <p>IACV-AAC VALVE      0</p> <p>[P0505]</p> </div>		<div style="border: 1px solid black; padding: 5px;"> <p style="text-align: center;">■ SELF-DIAG RESULTS ■ <input type="checkbox"/></p> <p>FAILURE DETECTED    TIME</p> <p>IACV-AAC VALVE      [1t]</p> <p>[P0505]</p> </div>
DTC display		1st trip DTC display	
	<div style="display: flex; justify-content: space-around; border-top: 1px solid black;"> <span>ERASE</span> <span>PRINT</span> <span>FFdata</span> </div>		<div style="display: flex; justify-content: space-around; border-top: 1px solid black;"> <span>ERASE</span> <span>PRINT</span> <span>FFdata</span> </div>

SEF180U

GI  
MA  
EM  
LC  
EC  
FE  
CL  
MT  
AT  
TF  
PD  
FA  
RA  
BR  
ST  
RS  
BT  
HA  
EL  
IDX

# ON BOARD DIAGNOSTIC SYSTEM DESCRIPTION

Emission-related Diagnostic Information (Cont'd)

## FREEZE FRAME DATA AND 1ST TRIP FREEZE FRAME DATA

NEEC0030502

The ECM records the driving conditions such as fuel system status, calculated load value, engine coolant temperature, short term fuel trim, long term fuel trim, engine speed, vehicle speed and absolute pressure at the moment a malfunction is detected.

Data which are stored in the ECM memory, along with the 1st trip DTC, are called 1st trip freeze frame data. The data, stored together with the DTC data, are called freeze frame data and displayed on CONSULT or GST. The 1st trip freeze frame data can only be displayed on the CONSULT screen, not on the GST. For details, see EC-70.

Only one set of freeze frame data (either 1st trip freeze frame data or freeze frame data) can be stored in the ECM. 1st trip freeze frame data is stored in the ECM memory along with the 1st trip DTC. There is no priority for 1st trip freeze frame data and it is updated each time a different 1st trip DTC is detected. However, once freeze frame data (2nd trip detection/MIL on) is stored in the ECM memory, 1st trip freeze frame data is no longer stored. Remember, only one set of freeze frame data can be stored in the ECM. The ECM has the following priorities to update the data.

Priority	Items	
1	Freeze frame data	Misfire — DTC: P0300 - P0306 (0701, 0603 - 0608) Fuel Injection System Function — DTC: P0171 (0115), P0172 (0114)
2		Except the above items (Includes A/T related items)
3	1st trip freeze frame data	

For example, the EGR malfunction (Priority: 2) was detected and the freeze frame data was stored in the 2nd trip. After that when the misfire (Priority: 1) is detected in another trip, the freeze frame data will be updated from the EGR malfunction to the misfire. The 1st trip freeze frame data is updated each time a different malfunction is detected. There is no priority for 1st trip freeze frame data. However, once freeze frame data is stored in the ECM memory, 1st trip freeze data is no longer stored (because only one freeze frame data or 1st trip freeze frame data can be stored in the ECM). If freeze frame data is stored in the ECM memory and freeze frame data with the same priority occurs later, the first (original) freeze frame data remains unchanged in the ECM memory.

Both 1st trip freeze frame data and freeze frame data (along with the DTCs) are cleared when the ECM memory is erased. Procedures for clearing the ECM memory are described in "HOW TO ERASE EMISSION-RELATED DIAGNOSTIC INFORMATION", EC-55.

## SYSTEM READINESS TEST (SRT) CODE

NEEC0030503

System Readiness Test (SRT) code is specified in Mode 1 of SAE J1979. It indicates whether the self-diagnostic tests for non-continuously monitored items have been completed or not.

Inspection/Maintenance (I/M) tests of the on board diagnostic (OBD) II system may become the legal requirements in some states/areas. All SRT codes must be set in this case. Unless all SRT codes are set, conducting the I/M test may not be allowed.

SRT codes are set after self-diagnosis has been performed one or more times. This occurs regardless of whether the diagnosis is in "OK" or "NG", and whether or not the diagnosis is performed in consecutive trips. The following table lists the 5 SRT items (30 test items) for the ECM used in D22 models.

SRT items	Self-diagnostic test items
Catalyst monitoring	<ul style="list-style-type: none"> <li>• Three way catalyst function (right bank) P0420 (0702)</li> <li>• Three way catalyst function (left bank) P0430 (0703)</li> </ul>
EVAP system monitoring	<ul style="list-style-type: none"> <li>• EVAP control system (Small leak — negative pressure) P0440 (0705)</li> <li>• EVAP control system (Small leak — positive pressure) P1440 (0213)</li> <li>• EVAP control system purge flow monitoring P1447 (0111)</li> </ul>

# ON BOARD DIAGNOSTIC SYSTEM DESCRIPTION

*Emission-related Diagnostic Information (Cont'd)*

SRT Items	Self-diagnostic test items	
Oxygen sensor monitoring	Right bank	<ul style="list-style-type: none"> <li>• Front heated oxygen sensor (Circuit) P0130 (0503)</li> <li>• Front heated oxygen sensor (Lean shift monitoring) P0131 (0415)</li> <li>• Front heated oxygen sensor (Rich shift monitoring) P0132 (0414)</li> <li>• Front heated oxygen sensor (Response monitoring) P0133 (0413)</li> <li>• Front heated oxygen sensor (High voltage) P0134 (0509)</li> </ul>
	Left bank	<ul style="list-style-type: none"> <li>• Front heated oxygen sensor (Circuit) P0150 (0303)</li> <li>• Front heated oxygen sensor (Lean shift monitoring) P0151 (0411)</li> <li>• Front heated oxygen sensor (Rich shift monitoring) P0152 (0410)</li> <li>• Front heated oxygen sensor (Response monitoring) P0153 (0409)</li> <li>• Front heated oxygen sensor (High voltage) P0154 (0412)</li> </ul>
	Right bank	<ul style="list-style-type: none"> <li>• Rear heated oxygen sensor (Min. voltage monitoring) P0137 (0511)</li> <li>• Rear heated oxygen sensor (Max. voltage monitoring) P0138 (0510)</li> <li>• Rear heated oxygen sensor (Response monitoring) P0139 (0707)</li> <li>• Rear heated oxygen sensor (High voltage) P0140 (0512)</li> </ul>
	Left bank	<ul style="list-style-type: none"> <li>• Rear heated oxygen sensor (Min. voltage monitoring) P0157 (0314)</li> <li>• Rear heated oxygen sensor (Max. voltage monitoring) P0158 (0313)</li> <li>• Rear heated oxygen sensor (Response monitoring) P0159 (0708)</li> <li>• Rear heated oxygen sensor (High voltage) P0160 (0315)</li> </ul>
Oxygen sensor heater monitoring	<ul style="list-style-type: none"> <li>• Front heated oxygen sensor heater (right bank) P0135 (0901)</li> <li>• Rear heated oxygen sensor heater (right bank) P0141 (0902)</li> <li>• Front heated oxygen sensor heater (left bank) P0155 (1001)</li> <li>• Rear heated oxygen sensor heater (left bank) P0161 (1002)</li> </ul>	
EGR system monitoring	<ul style="list-style-type: none"> <li>• EGR function (close) P0400 (0302)</li> <li>• EGRC-BPT valve function P0402 (0306)</li> <li>• EGR function (open) P1402 (0514)</li> </ul>	

Together with the DTC, the SRT code is cleared from the ECM memory using the method described later (Refer to EC-55). In addition, after the engine control components/system are repaired or if the battery terminals remain disconnected for more than 24 hours, all SRT codes may be cleared from the ECM memory.

## How to Display SRT Code

NEEC0030S0301

### 1. With CONSULT

Selecting "SRT STATUS" in "DTC CONFIRMATION" mode with CONSULT.

For items whose SRT codes are set, a "CMPLT" is displayed on the CONSULT screen; for items whose SRT codes are not set, "INCMP" is displayed.

### 2. With GST

Selecting Mode 1 with GST (Generic Scan Tool)

A sample of CONSULT display for SRT code is shown below.

"INCMP" means the self-diagnosis is incomplete and SRT is not set. "CMPLT" means the self-diagnosis is complete and SRT is set.

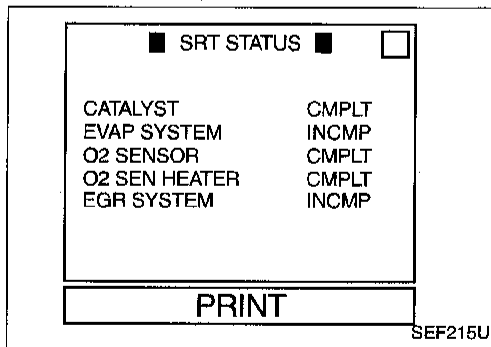

## ON BOARD DIAGNOSTIC SYSTEM DESCRIPTION

*Emission-related Diagnostic Information (Cont'd)*

---

### **How to Set SRT Code**

NEEC0030S0302

To set all SRT codes, self-diagnosis for the items indicated above must be performed one or more times. Each diagnosis may require a long period of actual driving under various conditions. The most efficient driving pattern in which SRT codes can be properly set is explained on the next page. The driving pattern should be performed one or more times to set all SRT codes.

# ON BOARD DIAGNOSTIC SYSTEM DESCRIPTION

Emission-related Diagnostic Information (Cont'd)

## Driving Pattern

**Note:** Always drive vehicle in safe manner according to traffic conditions and obey all traffic laws. Refer to next page for more information and explanation of chart.

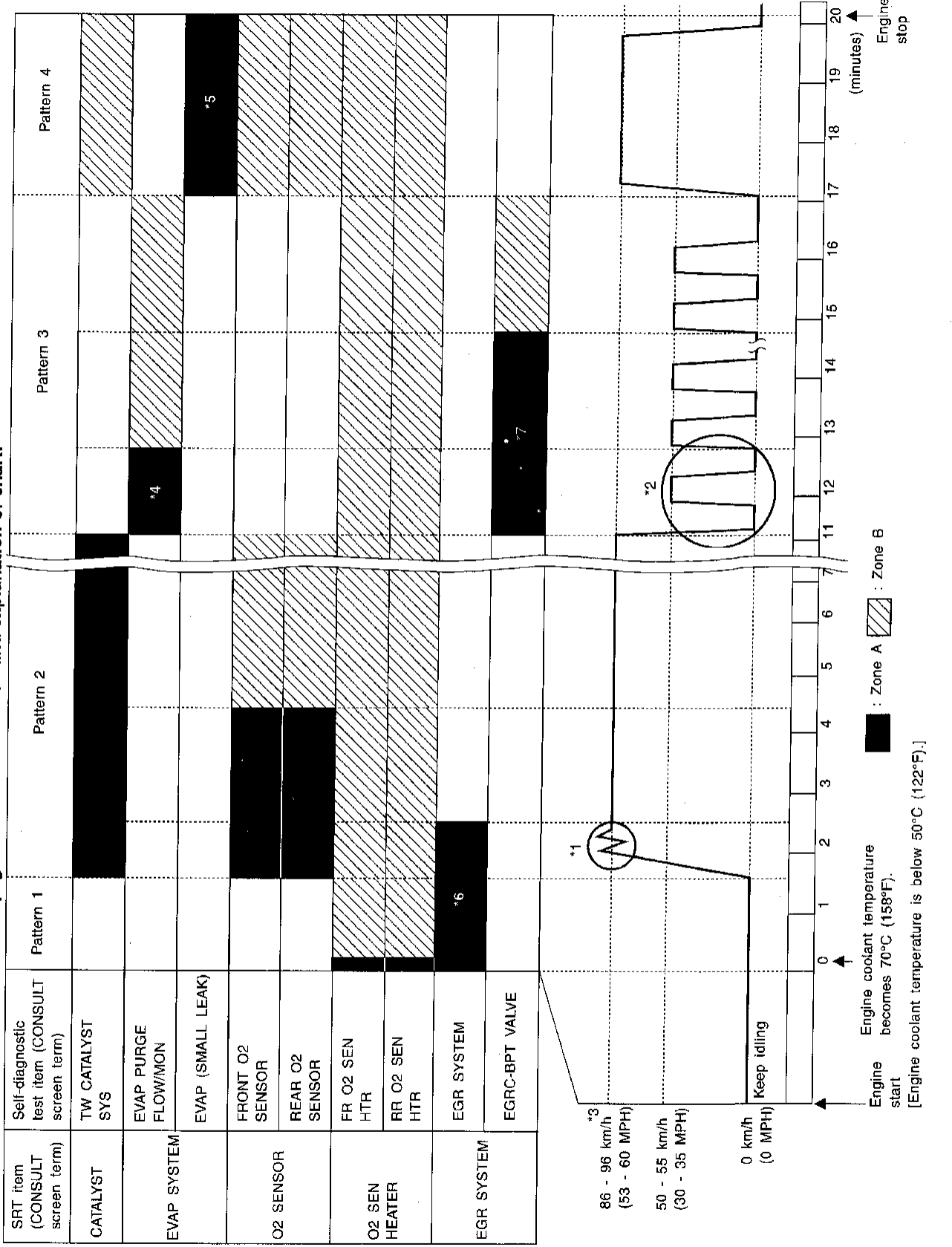

SEF933V

# ON BOARD DIAGNOSTIC SYSTEM DESCRIPTION

## Emission-related Diagnostic Information (Cont'd)

- The time required for each diagnosis varies with road surface conditions, weather, altitude, individual driving habits, etc.  
Zone A refers to the range where the time required, for the diagnosis under normal conditions\*, is the shortest.  
Zone B refers to the range where the diagnosis can still be performed if the diagnosis is not completed within zone A.

\*: Normal conditions refer to the following:

- Sea level
- Flat road
- Ambient air temperature: 20 - 30°C (68 - 86°F)
- Diagnosis is performed as quickly as possible under normal conditions.  
Under different conditions [For example: ambient air temperature other than 20 - 30°C (68 - 86°F)], diagnosis may also be performed.

Pattern 1:

- **The engine is started at the engine coolant temperature of -10 to 35°C (14 to 95°F) (where the voltage between the ECM terminals 59 and 43 is 3.0 - 4.3V).**
- **The engine must be operated at idle speed until the engine coolant temperature is greater than 70°C (158°F) (where the voltage between the ECM terminals 59 and 43 is lower than 1.4V).**
- **The engine is started at the tank fuel temperature of warmer than 0°C (32°F) (where the voltage between the ECM terminal 60 and ground is less than 4.1V).**

Pattern 2:

- When steady-state driving is performed again even after it is interrupted, each diagnosis can be conducted. In this case, the time required for diagnosis may be extended.

Pattern 3:

- The driving pattern outlined in \*2 must be repeated at least 3 times.

Pattern 4:

- Tests are performed after the engine has been operated for at least 17 minutes.
- The accelerator pedal must be held very steady during steady-state driving.
- If the accelerator pedal is moved, the test must be conducted all over again.

\*1: Depress the accelerator pedal until vehicle speed is 90 km/h (56 MPH), then release the accelerator pedal and keep it released for more than 10 seconds. Depress the accelerator pedal until vehicle speed is 90 km/h (56 MPH) again.

\*2: Operate the vehicle in the following driving pattern.

- 1) Decelerate vehicle to 0 km/h (0 MPH) and let engine idle.
- 2) Repeat driving pattern shown below at least 10 times.
  - **During acceleration, hold the accelerator pedal as steady as possible. (The THROTL POS SEN value of CONSULT should be between 0.8 to 1.2V.)**
- 3) Repeat steps 1 and 2 until the EGR system SRT is set.

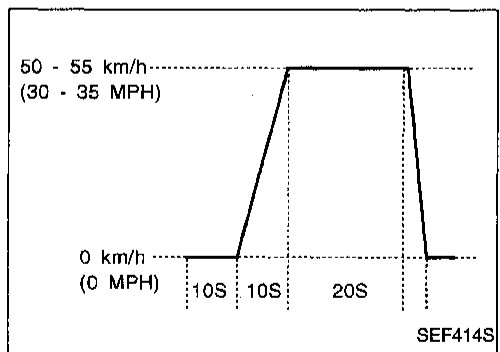

\*3: Checking the vehicle speed with CONSULT or GST is advised.

\*4: The driving pattern may be omitted when "PURG FLOW P1447" is performed using the "DTC WORK SUPPORT" mode with CONSULT.



# ON BOARD DIAGNOSTIC SYSTEM DESCRIPTION

Emission-related Diagnostic Information (Cont'd)

\*5: The driving pattern may be omitted when "EVAP SML LEAK P0440" is performed using the "DTC WORK SUPPORT" mode with CONSULT.

\*6: The driving pattern may be omitted when all the followings are performed using the "DTC WORK SUPPORT" mode with CONSULT.

- "EGR SYSTEM P0400"
- "EGR SYSTEM P1402"

\*7: The driving pattern may be omitted when "EGRC-BPT/VLV P0402" is performed using the "DTC WORK SUPPORT" mode with CONSULT.

## Suggested Transmission Gear Position for A/T Models

Set the selector lever in the "D" position with the overdrive switch turned ON.

## Suggested upshift speeds for M/T models

Shown below are suggested vehicle speeds for shifting into a higher gear. These suggestions relate to fuel economy and vehicle performance. Actual upshift speeds will vary according to road conditions, the weather and individual driving habits.

Gear change	For normal acceleration in low altitude areas [less than 1,219 m (4,000 ft)]:		For quick acceleration in low altitude areas and high altitude areas [over 1,219 m (4,000 ft)]:
	ACCEL shift point km/h (MPH)	CRUISE shift point km/h (MPH)	km/h (MPH)
1st to 2nd	24 (15)	24 (15)	24 (15)
2nd to 3rd	40 (25)	29 (18)	40 (25)
3rd to 4th	58 (36)	48 (30)	64 (40)
4th to 5th	64 (40)	63 (39)	72 (45)

## Suggested Maximum Speed in Each Gear

Downshift to a lower gear if the engine is not running smoothly, or if you need to accelerate.

Do not exceed the maximum suggested speed (shown below) in any gear. For level road driving, use the highest gear suggested for that speed. Always observe posted speed limits and drive according to the road conditions to ensure safe operation. Do not over-rev the engine when shifting to a lower gear as it may cause engine damage or loss of vehicle control.

Gear	km/h (MPH) 2WD (AUTO mode)
1st	50 (30)
2nd	95 (60)

## TEST VALUE AND TEST LIMIT (GST ONLY — NOT APPLICABLE TO CONSULT)

NEEC0030S07

The following is the information specified in Mode 6 of SAE J1979.

The test value is a parameter used to determine whether a system/circuit diagnostic test is "OK" or "NG" while being monitored by the ECM during self-diagnosis. The test limit is a reference value which is specified as the maximum or minimum value and is compared with the test value being monitored.

Items for which these data (test value and test limit) are displayed are the same as SRT code items (30 test items).

These data (test value and test limit) are specified by Test ID (TID) and Component ID (CID) and can be displayed on the GST screen.

X: Applicable —: Not applicable

SRT item	Self-diagnostic test item	Test value (GST display)		Test limit	Application
		TID	CID		
CATALYST	Three way catalyst function (Right bank)	01H	01H	Max.	X
	Three way catalyst function (Left bank)	03H	02H	Max.	X

## ON BOARD DIAGNOSTIC SYSTEM DESCRIPTION

*Emission-related Diagnostic Information (Cont'd)*

SRT item	Self-diagnostic test item	Test value (GST display)		Test limit	Application
		TID	CID		
EVAP SYSTEM	EVAP control system (Small leak)	05H	03H	Max.	X
	EVAP control system purge flow monitoring	06H	83H	Min.	X
O2 SENSOR	Front heated oxygen sensor (Right bank)	09H	04H	Max.	X
		0AH	84H	Min.	X
		0BH	04H	Max.	X
		0CH	04H	Max.	X
		0DH	04H	Max.	X
	Front heated oxygen sensor (Left bank)	11H	05H	Max.	X
		12H	85H	Min.	X
		13H	05H	Max.	X
		14H	05H	Max.	X
		15H	05H	Max.	X
	Rear heated oxygen sensor (Right bank)	19H	86H	Min.	X
		1AH	86H	Min.	X
		1BH	06H	Max.	X
		1CH	06H	Max.	X
	Rear heated oxygen sensor (Left bank)	21H	87H	Min.	X
		22H	87H	Min.	X
23H		07H	Max.	X	
24H		07H	Max.	X	
O2 SENSOR HEATER	Front heated oxygen sensor heater (Right bank)	29H	08H	Max.	X
		2AH	88H	Min.	X
	Front heated oxygen sensor heater (Left bank)	2BH	09H	Max.	X
		2CH	89H	Min.	X
	Rear heated oxygen sensor heater (Right bank)	2DH	0AH	Max.	X
		2EH	8AH	Min.	X
	Rear heated oxygen sensor heater (Left bank)	2FH	0BH	Max.	X
		30H	8BH	Min.	X
EGR SYSTEM	EGR function	31H	8CH	Min.	X
		32H	8CH	Min.	X
		33H	8CH	Min.	X
		34H	8CH	Min.	X
		35H	0CH	Max.	X
	EGRC-BPT valve function	36H	0CH	Max.	X
		37H	8CH	Min.	X

# ON BOARD DIAGNOSTIC SYSTEM DESCRIPTION

*Emission-related Diagnostic Information (Cont'd)*

## EMISSION-RELATED DIAGNOSTIC INFORMATION ITEMS

X: Applicable —: Not applicable NEEC000005

Items (CONSULT screen terms)	DTC*4		SRT code	Test value/ Test limit (GST only)	1st trip DTC*4	Reference page
	CONSULT GST*2	ECM*1				
<b>NO SELF DIAGNOSTIC FAILURE INDICATED</b>	<b>P0000</b>	<b>0505</b>	—	—	—	—
MAF SEN/CIRCUIT	P0100	0102	—	—	X	EC-121
ABSL PRES SEN/CIRC	P0105	0803	—	—	X	EC-130
AIR TEMP SEN/CIRC	P0110	0401	—	—	X	EC-139
COOLANT T SEN/CIRC	P0115	0103	—	—	X	EC-145
THRTL POS SEN/CIRC	P0120	0403	—	—	X	EC-150
*COOLAN T SEN/CIRC	P0125	0908	—	—	X	EC-161
FRONT O2 SENSOR-B1	P0130	0503	X	X	X*3	EC-166
FRONT O2 SENSOR-B1	P0131	0415	X	X	X*3	EC-174
FRONT O2 SENSOR-B1	P0132	0414	X	X	X*3	EC-180
FRONT O2 SENSOR-B1	P0133	0413	X	X	X*3	EC-186
FRONT O2 SENSOR-B1	P0134	0509	X	X	X*3	EC-194
FR O2 SE HEATER-B1	P0135	0901	X	X	X*3	EC-202
REAR O2 SENSOR-B1	P0137	0511	X	X	X*3	EC-208
REAR O2 SENSOR-B1	P0138	0510	X	X	X*3	EC-217
REAR O2 SENSOR-B1	P0139	0707	X	X	X*3	EC-225
REAR O2 SENSOR-B1	P0140	0512	X	X	X*3	EC-234
RR O2 SE HEATER-B1	P0141	0902	X	X	X*3	EC-241
FRONT O2 SENSOR-B2	P0150	0303	X	X	X*3	EC-166
FRONT O2 SENSOR-B2	P0151	0411	X	X	X*3	EC-174
FRONT O2 SENSOR-B2	P0152	0410	X	X	X*3	EC-180
FRONT O2 SENSOR-B2	P0153	0409	X	X	X*3	EC-186
FRONT O2 SENSOR-B2	P0154	0412	X	X	X*3	EC-194
FR O2 SE HEATER-B2	P0155	1001	X	X	X*3	EC-202
REAR O2 SENSOR-B2	P0157	0314	X	X	X*3	EC-208
REAR O2 SENSOR-B2	P0158	0313	X	X	X*3	EC-217
REAR O2 SENSOR-B2	P0159	0708	X	X	X*3	EC-225
REAR O2 SENSOR-B2	P0160	0315	X	X	X*3	EC-234
RR O2 SE HEATER-B2	P0161	1002	X	X	X*3	EC-241
FUEL SYS LEAN/BK1	P0171	0115	—	—	X	EC-247
FUEL SYS RICH/BK1	P0172	0114	—	—	X	EC-254
FUEL SYS LEAN/BK2	P0174	0210	—	—	X	EC-247
FUEL SYS RICH/BK2	P0175	0209	—	—	X	EC-254
FUEL TEMP SEN/CIRC	P0180	0402	—	—	X	EC-261

## ON BOARD DIAGNOSTIC SYSTEM DESCRIPTION

*Emission-related Diagnostic Information (Cont'd)*

Items (CONSULT screen terms)	DTC*4		SRT code	Test value/ Test limit (GST only)	1st trip DTC*4	Reference page
	CONSULT GST*2	ECM*1				
MULTI CYL MISFIRE	P0300	0701	—	—	X	EC-266
CYL 1 MISFIRE	P0301	0608	—	—	X	EC-266
CYL 2 MISFIRE	P0302	0607	—	—	X	EC-266
CYL 3 MISFIRE	P0303	0606	—	—	X	EC-266
CYL 4 MISFIRE	P0304	0605	—	—	X	EC-266
CYL 5 MISFIRE	P0305	0604	—	—	X	EC-266
CYL 6 MISFIRE	P0306	0603	—	—	X	EC-266
KNOCK SEN/CIRC	P0325	0304	—	—	—	EC-271
CPS/CIRCUIT (OBD)	P0335	0802	—	—	X	EC-276
CAM POS SEN/CIRC	P0340	0101	—	—	X	EC-281
EGR SYSTEM	P0400	0302	X	X	X*3	EC-288
EGRC-BPT VALVE	P0402	0306	X	X	X*3	EC-296
TW CATALYST SYS-B1	P0420	0702	X	X	X*3	EC-300
TW CATALYST SYS-B2	P0430	0703	X	X	X*3	EC-300
EVAP SMALL LEAK	P0440	0705	X	X	X*3	EC-303
PURG VOLUME CONT/V	P0443	1008	—	—	X	EC-310
VENT CONTROL VALVE	P0446	0903	—	—	X	EC-316
EVAPO SYS PRES SEN	P0450	0704	—	—	X	EC-322
VEH SPEED SEN/CIRC	P0500	0104	—	—	X	EC-330
IACV/AAC VLV/CIRC	P0505	0205	—	—	X	EC-335
CLOSED TP SW/CIRC	P0510	0203	—	—	X	EC-342
A/T COMM LINE	P0600	—	—	—	—	EC-348
ECM	P0605	0301	—	—	X	EC-352
PNP SW/CIRC	P0705	1101	—	—	X	AT-87
ATF TEMP SEN/CIRC	P0710	1208	—	—	X	AT-92
VEH SPD SEN/CIR AT	P0720	1102	—	—	X	AT-97
ENGINE SPEED SIG	P0725	1207	—	—	X	AT-102
A/T 1ST GR FNCTN	P0731	1103	—	—	X	AT-106
A/T 2ND GR FNCTN	P0732	1104	—	—	X	AT-112
A/T 3RD GR FNCTN	P0733	1105	—	—	X	AT-118
A/T 4TH GR FNCTN	P0734	1106	—	—	X	AT-124
TCC SOLENOID/CIRC	P0740	1204	—	—	X	AT-133
A/T TCC S/V FNCTN	P0744	1107	—	—	X	AT-138
L/PRESS SOL/CIRC	P0745	1205	—	—	X	AT-146
SFT SOL A/CIRC	P0750	1108	—	—	X	AT-151
SFT SOL B/CIRC	P0755	1201	—	—	X	AT-156

# ON BOARD DIAGNOSTIC SYSTEM DESCRIPTION

*Emission-related Diagnostic Information (Cont'd)*

Items (CONSULT screen terms)	DTC*4		SRT code	Test value/ Test limit (GST only)	1st trip DTC*4	Reference page
	CONSULT GST*2	ECM*1				
MAP/BARO SW SOL/CIR	P1105	1302	—	—	X	EC-354
CLOSED LOOP-B1	P1148	0307	—	—	X	EC-364
CLOSED LOOP-B2	P1168	0308	—	—	X	EC-364
IGN SIGNAL-PRIMARY	P1320	0201	—	—	X	EC-366
CPS/CIRC (OBD) COG	P1336	0905	—	—	X	EC-372
EGRC SOLENOID/V	P1400	1005	—	—	X	EC-377
EGR TEMP SEN/CIRC	P1401	0305	—	—	X	EC-382
EGR SYSTEM	P1402	0514	X	X	X*3	EC-389
EVAP SMALL LEAK	P1440	0213	X	X	X*3	EC-395
PURG VOLUME CONT/V	P1444	0214	—	—	X	EC-402
VENT CONTROL VALVE	P1446	0215	—	—	X	EC-409
EVAP PURG FLOW/MON	P1447	0111	X	X	X*3	EC-414
VENT CONTROL VALVE	P1448	0309	—	—	X	EC-420
VC/V BYPASS/V	P1490	0801	—	—	X	EC-427
VC CUT/V BYPASS/V	P1491	0311	—	—	X	EC-432
A/T DIAG COMM LINE	P1605	0804	—	—	X	EC-439
TP SEN/CIRC A/T	P1705	1206	—	—	X	AT-161
P-N POS SW/CIRCUIT	P1706	1003	—	—	X	EC-442
O/R CLTCH SOL/CIRC	P1760	1203	—	—	X	AT-168

\*1: In Diagnostic Test Mode II (Self-diagnostic results). These numbers are controlled by NISSAN.

\*2: These numbers are prescribed by SAE J2012.

\*3: These are not displayed with GST.

\*4: 1st trip DTC No. is the same as DTC No.

**NOTE:**

Regarding D22 models, “-B1” and “BK1” indicate right bank and “-B2” and “BK2” indicate left bank.

## HOW TO ERASE EMISSION-RELATED DIAGNOSTIC INFORMATION

### How to Erase DTC (Ⓟ With CONSULT)

NEEC0030S06

NEEC0030S0601

**NOTE:**

**If the DTC is not for A/T related items (see EC-2), skip steps 2 through 4.**

1. If the ignition switch stays “ON” after repair work, be sure to turn ignition switch “OFF” once. Wait at least 5 seconds and then turn it “ON” (engine stopped) again.
  2. Turn CONSULT “ON” and touch “A/T”.
  3. Touch “SELF-DIAG RESULTS”.
  4. Touch “ERASE”. [The DTC in the TCM (Transmission control module) will be erased.] Then touch “BACK” twice.
  5. Touch “ENGINE”.
  6. Touch “SELF-DIAG RESULTS”.
  7. Touch “ERASE”. (The DTC in the ECM will be erased.)
- If DTCs are displayed for both ECM and TCM (Transmission control module), they need to be erased individually from the ECM and TCM (Transmission control module).

# ON BOARD DIAGNOSTIC SYSTEM DESCRIPTION

## Emission-related Diagnostic Information (Cont'd)

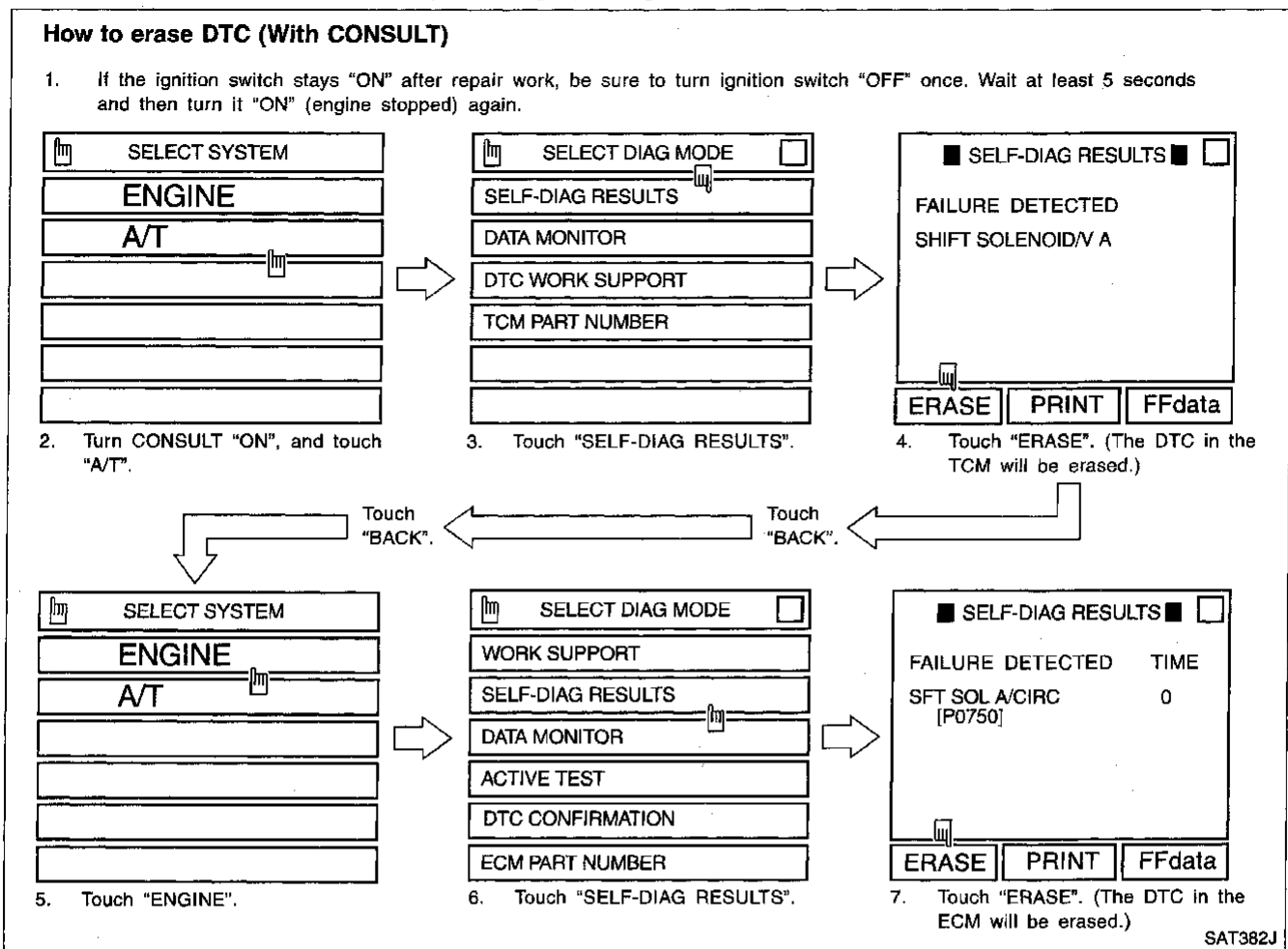

The emission related diagnostic information in the ECM can be erased by selecting "ERASE" in the "SELF-DIAG RESULTS" mode with CONSULT.

### How to Erase DTC (Ⓢ) With GST

#### NOTE:

If the DTC is not for A/T related items (see EC-2), skip step 2.

- If the ignition switch stays "ON" after repair work, be sure to turn ignition switch "OFF" once. Wait at least 5 seconds and then turn it "ON" (engine stopped) again.
- Perform "SELF-DIAGNOSTIC PROCEDURE (Without CONSULT)" in AT section titled "TROUBLE DIAGNOSIS", "Self-diagnosis". (The engine warm-up step can be skipped when performing the diagnosis only to erase the DTC.)
- Select Mode 4 with GST (Generic Scan Tool).

The emission related diagnostic information in the ECM can be erased by selecting Mode 4 with GST.

### How to Erase DTC (Ⓢ) No Tools

#### NOTE:

If the DTC is not for A/T related items (see EC-2), skip step 2.

- If the ignition switch stays "ON" after repair work, be sure to turn ignition switch "OFF" once. Wait at least 5 seconds and then turn it "ON" again.
- Perform "SELF-DIAGNOSTIC PROCEDURE (Without CONSULT)" in AT section titled "TROUBLE DIAGNOSIS", "Self-diagnosis".  
(The engine warm-up step can be skipped when performing the diagnosis only to erase the DTC.)
- Change the diagnostic test mode from Mode II to Mode I by turning the mode selector on the ECM. (See EC-59.)

The emission related diagnostic information in the ECM can be erased by changing the diagnostic test mode from Diagnostic Test Mode II to Mode I by turning the mode selector on the ECM.

# ON BOARD DIAGNOSTIC SYSTEM DESCRIPTION

Emission-related Diagnostic Information (Cont'd)

- If the battery is disconnected, the emission-related diagnostic information will be lost after approx. 24 hours.
- Erasing the emission-related diagnostic information using CONSULT or GST is easier and quicker than switching the mode selector on the ECM.
- The following data are cleared when the ECM memory is erased.
  - 1) Diagnostic trouble codes
  - 2) 1st trip diagnostic trouble codes
  - 3) Freeze frame data
  - 4) 1st trip freeze frame data
  - 5) System readiness test (SRT) codes
  - 6) Test values
  - 7) Others

Actual work procedures are explained using a DTC as an example. Be careful so that not only the DTC, but all of the data listed above, are cleared from the ECM memory during work procedures.

## Malfunction Indicator Lamp (MIL)

### DESCRIPTION

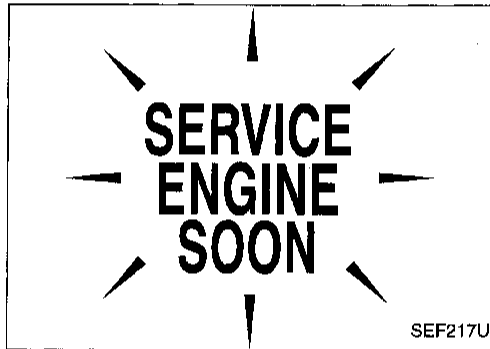

The MIL is located on the instrument panel.

1. The MIL will light up when the ignition switch is turned ON without the engine running. This is a bulb check.
  - If the MIL does not light up, refer to EL section ("WARNING LAMPS") or see EC-482.
2. When the engine is started, the MIL should go off.  
If the MIL remains on, the on board diagnostic system has detected an engine system malfunction.







# ON BOARD DIAGNOSTIC SYSTEM DESCRIPTION

Malfunction Indicator Lamp (MIL) (Cont'd)

## On Board Diagnostic System Function

=NEEC0031S01

The on board diagnostic system has the following four functions.

Diagnostic Test Mode	KEY and ENG. Status	Function	Explanation of Function
Mode I	Ignition switch in "ON" position  Engine stopped 	BULB CHECK	This function checks the MIL bulb for damage (blown, open circuit, etc.). If the MIL does not come on, check MIL circuit and ECM test mode selector. (See EC-59.)
	Engine running 	MALFUNCTION WARNING	This is a usual driving condition. When a malfunction is detected twice in two consecutive driving cycles (two trip detection logic), the MIL will light up to inform the driver that a malfunction has been detected. The following malfunctions will light up or blink the MIL in the 1st trip. <ul style="list-style-type: none"> <li>• "Misfire (Possible three way catalyst damage)"</li> <li>• "Closed loop control"</li> <li>• Fail-safe mode</li> </ul>
Mode II	Ignition switch in "ON" position  Engine stopped 	SELF-DIAGNOSTIC RESULTS	This function allows DTCs and 1st trip DTCs to be read.
	Engine running 	FRONT HEATED OXYGEN SENSOR MONITOR	This function allows the fuel mixture condition (lean or rich), monitored by front heated oxygen sensor, to be read.

### MIL Flashing without DTC

NEEC0031S0101

If the ECM is in Diagnostic Test Mode II, MIL may flash when engine is running. In this case, check ECM test mode selector following "How to Switch Diagnostic Test Modes", EC-59.

How to switch the diagnostic test (function) modes, and details of the above functions are described later. (Refer to EC-59.)

The following emission-related diagnostic information is cleared when the ECM memory is erased.

- 1) Diagnostic trouble codes
- 2) 1st trip diagnostic trouble codes
- 3) Freeze frame data
- 4) 1st trip freeze frame data
- 5) System readiness test (SRT) codes
- 6) Test values
- 7) Others



# ON BOARD DIAGNOSTIC SYSTEM DESCRIPTION

Malfunction Indicator Lamp (MIL) (Cont'd)

## How to Switch Diagnostic Test Modes

NEEC0031S02

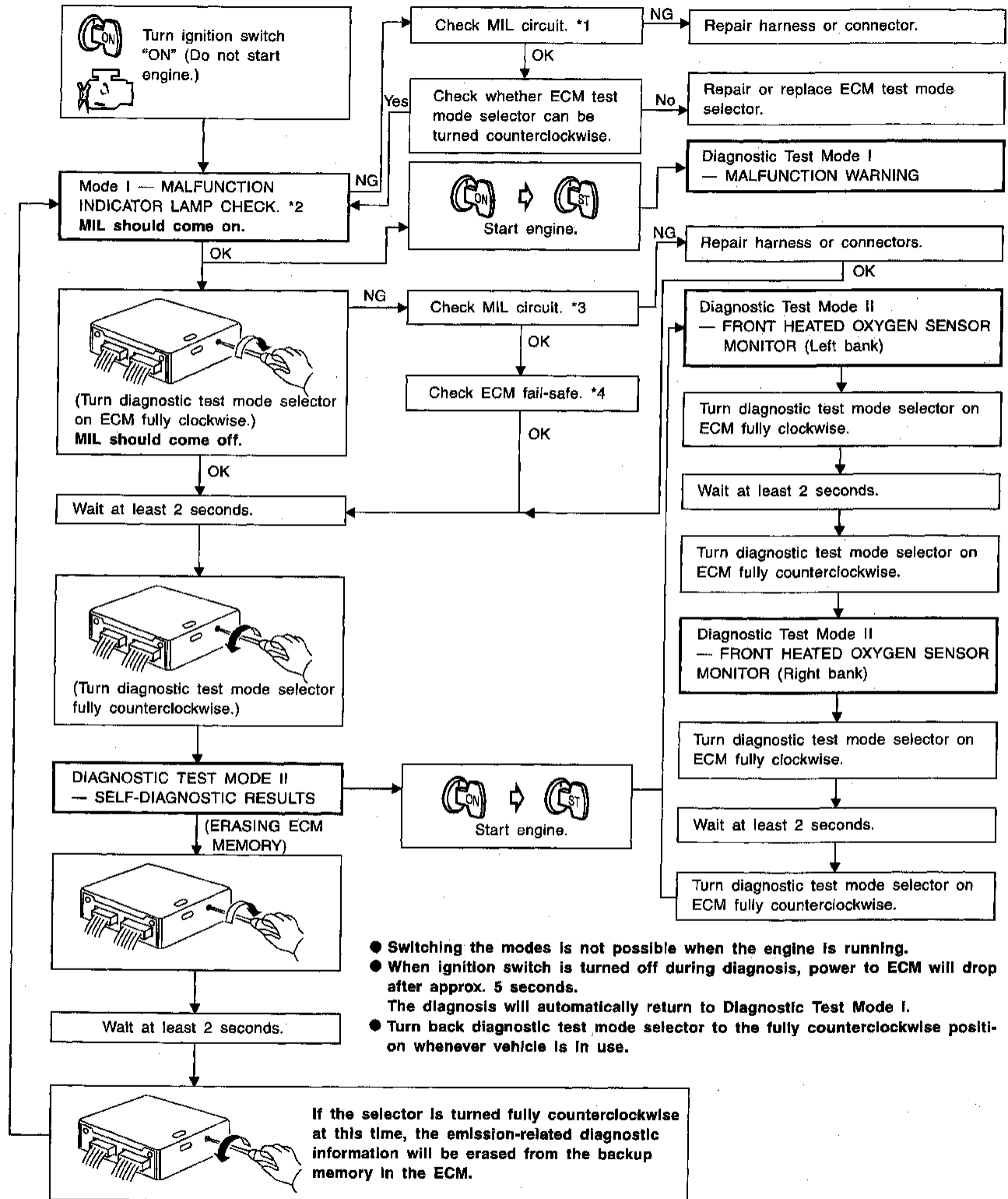

- Switching the modes is not possible when the engine is running.
- When ignition switch is turned off during diagnosis, power to ECM will drop after approx. 5 seconds. The diagnosis will automatically return to Diagnostic Test Mode I.
- Turn back diagnostic test mode selector to the fully counterclockwise position whenever vehicle is in use.

\*1 EC-482  
\*2 EC-57

\*3 EC-482

\*4 EC-96

SEF688W

# ON BOARD DIAGNOSTIC SYSTEM DESCRIPTION

Malfunction Indicator Lamp (MIL) (Cont'd)

## Diagnostic Test Mode I — Bulb Check

NEEC0031S03

In this mode, the MIL on the instrument panel should stay ON. If it remains OFF, check the bulb. Refer to EL section ("WARNING LAMPS") or see EC-482.

## Diagnostic Test Mode I — Malfunction Warning

NEEC0031S04

MIL	Condition
ON	When the malfunction is detected or the ECM's CPU is malfunctioning.
OFF	No malfunction.

- These DTC Numbers are clarified in Diagnostic Test Mode II (SELF-DIAGNOSTIC RESULTS).

## Diagnostic Test Mode II — Self-diagnostic Results

NEEC0031S05

In this mode, the DTC and 1st trip DTC are indicated by the number of blinks of the MIL.

The DTC and 1st trip DTC are displayed at the same time. If the MIL does not illuminate in diagnostic test mode I (Malfunction warning), all displayed items are 1st trip DTC's. If only one code is displayed when the MIL illuminates in diagnostic test mode II (SELF-DIAGNOSTIC RESULTS), it is a DTC; if two or more codes are displayed, they may be either DTC's or 1st trip DTC's. DTC No. is same as that of 1st trip DTC. These unidentified codes can be identified by using the CONSULT or GST. A DTC will be used as an example for how to read a code.

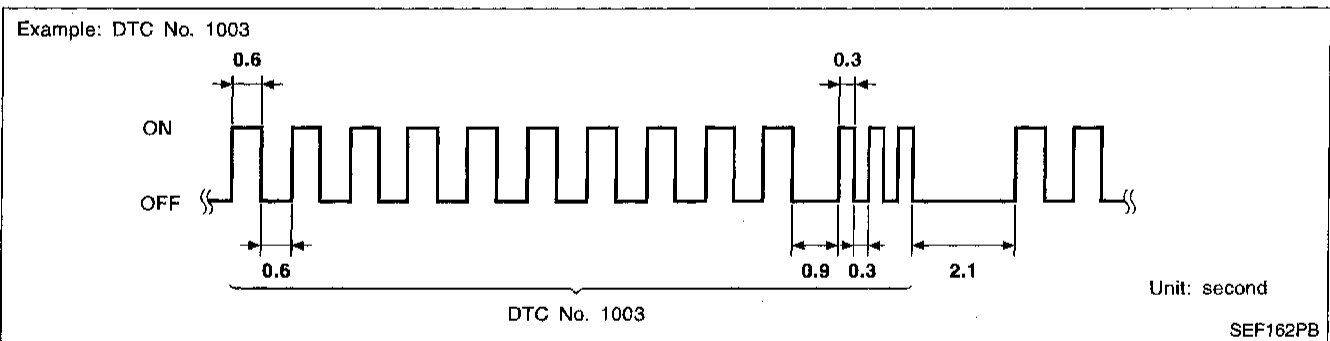
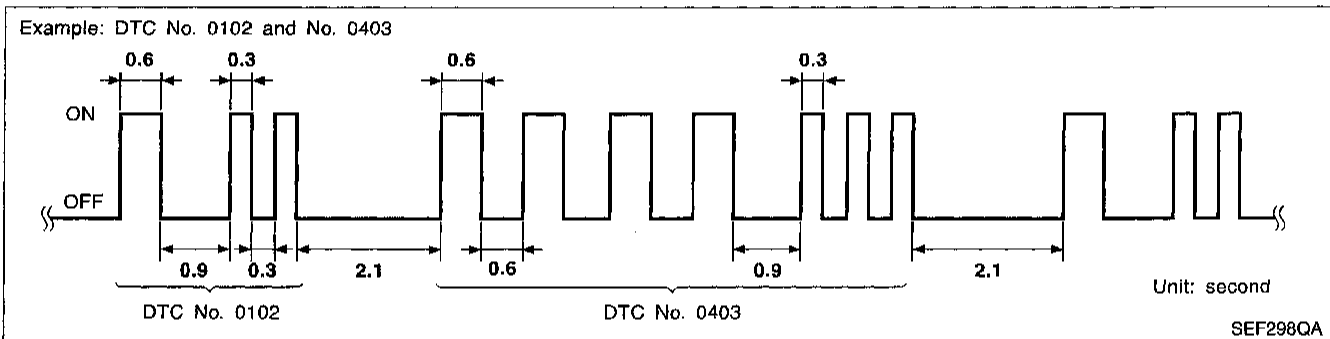

Long (0.6 second) blinking indicates the two LH digits of number and short (0.3 second) blinking indicates the two RH digits of number. For example, the MIL blinks 10 times for 6 seconds (0.6 sec x 10 times) and then it blinks three times for about 1 second (0.3 sec x 3 times). This indicates the DTC "1003" and refers to the malfunction of the park/neutral position (PNP) switch.

In this way, all the detected malfunctions are classified by their DTC numbers. The DTC "0505" refers to no malfunction. (See TROUBLE DIAGNOSIS — INDEX, EC-2.)

## How to Erase Diagnostic Test Mode II (Self-diagnostic Results)

NEEC0031S0501

The DTC can be erased from the backup memory in the ECM when the diagnostic test mode is changed from Diagnostic Test Mode II to Diagnostic Test Mode I. (Refer to "How to Switch Diagnostic Test Modes", EC-59.)

- If the battery is disconnected, the DTC will be lost from the backup memory after approx. 24 hours.
- Be careful not to erase the stored memory before starting trouble diagnoses.

# ON BOARD DIAGNOSTIC SYSTEM DESCRIPTION

*Malfunction Indicator Lamp (MIL) (Cont'd)*

## Diagnostic Test Mode II — Front Heated Oxygen Sensor Monitor

NEEC0031508

In this mode, the MIL displays the condition of the fuel mixture (lean or rich) which is monitored by the front heated oxygen sensor.

MIL	Fuel mixture condition in the exhaust gas	Air fuel ratio feedback control condition
ON	Lean	Closed loop system
OFF	Rich	
*Remains ON or OFF	Any condition	Open loop system

\*: Maintains conditions just before switching to open loop.

To check the front heated oxygen sensor function, start engine in the Diagnostic Test Mode II and warm it up until engine coolant temperature indicator points to the middle of the gauge.

Next run engine at about 2,000 rpm for about 2 minutes under no-load conditions. Then make sure that the MIL comes ON more than 5 times within 10 seconds with engine running at 2,000 rpm under no-load.

## OBD System Operation Chart

NEEC0032

### RELATIONSHIP BETWEEN MIL, 1ST TRIP DTC, DTC, AND DETECTABLE ITEMS

NEEC0032501

- When a malfunction is detected for the first time, the 1st trip DTC and the 1st trip freeze frame data are stored in the ECM memory.
- When the same malfunction is detected in two consecutive trips, the DTC and the freeze frame data are stored in the ECM memory, and the MIL will come on. For details, refer to "Two Trip Detection Logic" on EC-44.
- The MIL will go off after the vehicle is driven 3 times with no malfunction. The drive is counted only when the recorded driving pattern is met (as stored in the ECM). If another malfunction occurs while counting, the counter will reset.
- The DTC and the freeze frame data will be stored until the vehicle is driven 40 times (driving pattern A) without the same malfunction recurring (except for Misfire and Fuel Injection System). For Misfire and Fuel Injection System, the DTC and freeze frame data will be stored until the vehicle is driven 80 times (driving pattern C) without the same malfunction recurring. The "TIME" in "SELF-DIAGNOSTIC RESULTS" mode of CONSULT will count the number of times the vehicle is driven.
- The 1st trip DTC is not displayed when the self-diagnosis results in "OK" for the 2nd trip.

### SUMMARY CHART

NEEC0032502

Items	Fuel Injection System	Misfire	Other
MIL (goes off)	3 (pattern B)	3 (pattern B)	3 (pattern B)
DTC, Freeze Frame Data (no display)	80 (pattern C)	80 (pattern C)	40 (pattern A)
1st Trip DTC (clear)	1 (pattern C), *1	1 (pattern C), *1	1 (pattern B)
1st Trip Freeze Frame Data (clear)	*1, *2	*1, *2	1 (pattern B)

For details about patterns "B" and "C" under "Fuel Injection System" and "Misfire", see EC-63.

For details about patterns "A" and "B" under "Other", see EC-65.

\*1: Clear timing is at the moment OK is detected.

\*2: Clear timing is when the same malfunction is detected in the 2nd trip.

# ON BOARD DIAGNOSTIC SYSTEM DESCRIPTION

OBD System Operation Chart (Cont'd)

## RELATIONSHIP BETWEEN MIL, DTC, 1ST TRIP DTC AND DRIVING PATTERNS FOR "MISFIRE" <EXHAUST QUALITY DETERIORATION>, "FUEL INJECTION SYSTEM"

NEEC0032S03

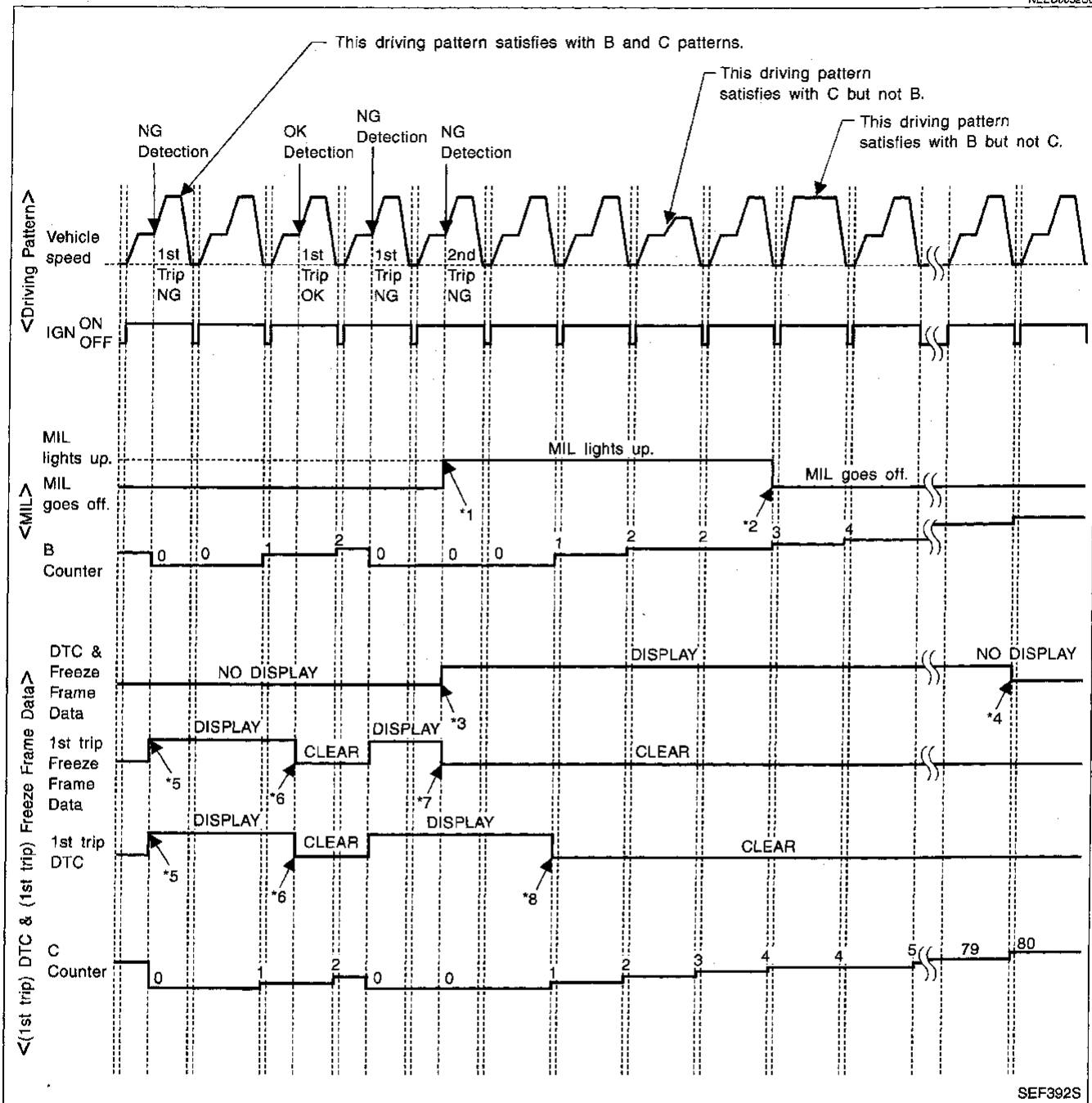

SEF392S

- \*1: When the same malfunction is detected in two consecutive trips, MIL will light up.
- \*2: MIL will go off after vehicle is driven 3 times (pattern B) without any malfunctions.
- \*3: When the same malfunction is detected in two consecutive trips, the DTC and the freeze frame data will be stored in ECM.
- \*4: The DTC and the freeze frame

- data will not be displayed any longer after vehicle is driven 80 times (pattern C) without the same malfunction. (The DTC and the freeze frame data still remain in ECM.)
- \*5: When a malfunction is detected for the first time, the 1st trip DTC and the 1st trip freeze frame data will be stored in ECM.
- \*6: The 1st trip DTC and the 1st trip

- freeze frame data will be cleared at the moment OK is detected.
- \*7: When the same malfunction is detected in the 2nd trip, the 1st trip freeze frame data will be cleared.
- \*8: 1st trip DTC will be cleared when vehicle is driven once (pattern C) without the same malfunction after DTC is stored in ECM.

# ON BOARD DIAGNOSTIC SYSTEM DESCRIPTION

OBD System Operation Chart (Cont'd)

## EXPLANATION FOR DRIVING PATTERNS FOR "MISFIRE <EXHAUST QUALITY DETERIORATION>", "FUEL INJECTION SYSTEM"

NEEC0032S04

### <Driving Pattern B>

NEEC0032S0401

Driving pattern B means the vehicle operation as follows:

All components and systems should be monitored at least once by the OBD system.

- The B counter will be cleared when the malfunction is detected once regardless of the driving pattern.
- The B counter will be counted up when driving pattern B is satisfied without any malfunction.
- The MIL will go off when the B counter reaches 3. (\*2 in "OBD SYSTEM OPERATION CHART")

### <Driving Pattern C>

NEEC0032S0402

Driving pattern C means the vehicle operation as follows:

1) The following conditions should be satisfied at the same time:

Engine speed: (Engine speed in the freeze frame data)  $\pm 375$  rpm

Calculated load value: (Calculated load value in the freeze frame data)  $\times (1 \pm 0.1)$  [%]

Engine coolant temperature (T) condition:

- When the freeze frame data shows lower than 70°C (158°F), "T" should be lower than 70°C (158°F).
- When the freeze frame data shows higher than or equal to 70°C (158°F), "T" should be higher than or equal to 70°C (158°F).

Example:

If the stored freeze frame data is as follows:

Engine speed: 850 rpm, Calculated load value: 30%, Engine coolant temperature: 80°C (176°F)

To be satisfied with driving pattern C, the vehicle should run under the following conditions:

Engine speed: 475 - 1,225 rpm, Calculated load value: 27 - 33%, Engine coolant temperature: more than 70°C (158°F)

- The C counter will be cleared when the malfunction is detected regardless of (1).
- The C counter will be counted up when (1) is satisfied without the same malfunction.
- The DTC will not be displayed after C counter reaches 80.
- The 1st trip DTC will be cleared when C counter is counted once without the same malfunction after DTC is stored in ECM.

GI

MA

EM

LC

EC

FE

CL

MT

AT

TF

PD

FA

RA

BR

ST

RS

BT

HA

EL

IDX

# ON BOARD DIAGNOSTIC SYSTEM DESCRIPTION

OBD System Operation Chart (Cont'd)

## RELATIONSHIP BETWEEN MIL, DTC, 1ST TRIP DTC AND DRIVING PATTERNS EXCEPT FOR "MISFIRE <EXHAUST QUALITY DETERIORATION>", "FUEL INJECTION SYSTEM"

NEEC0032605

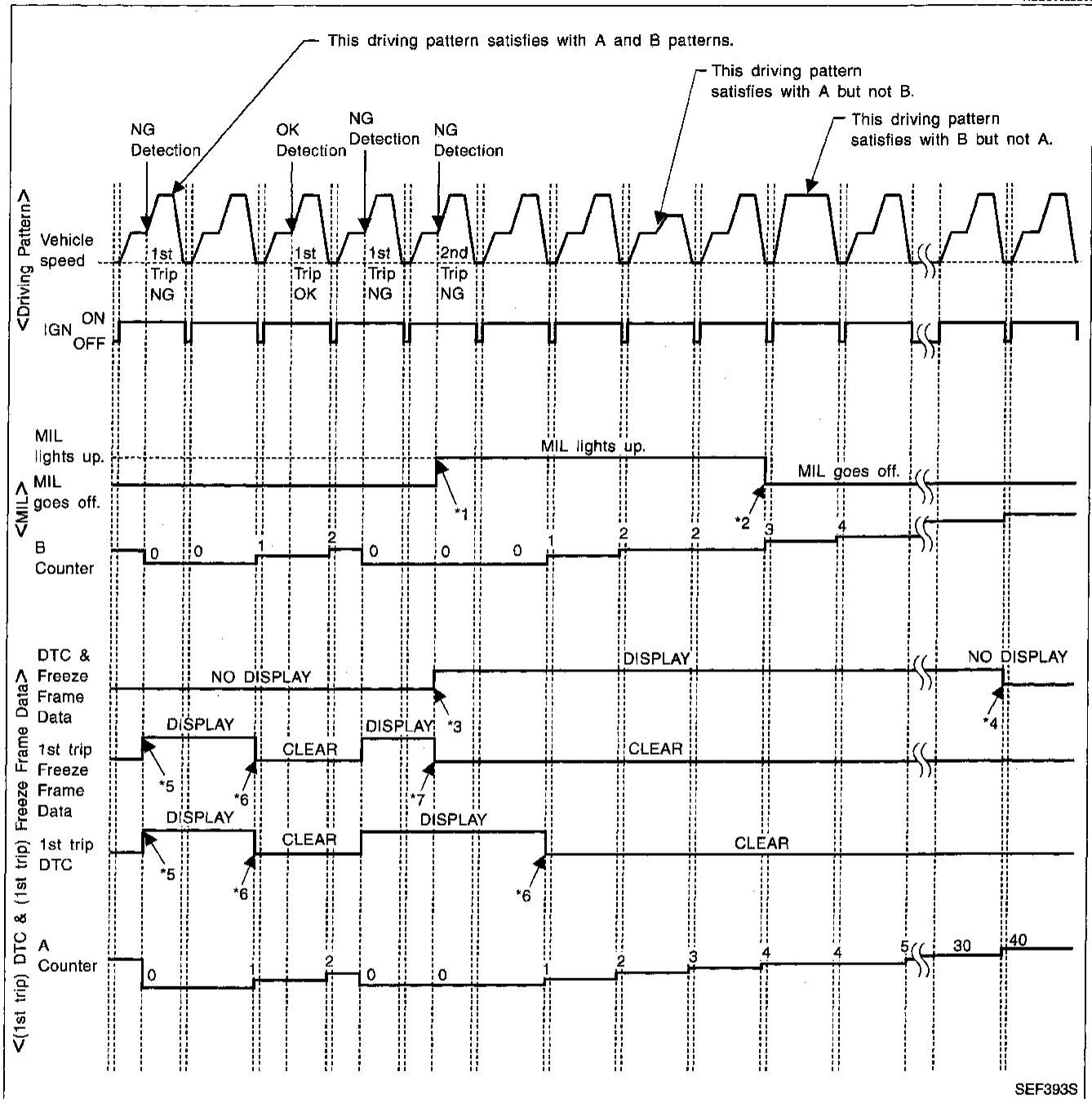

SEF393S

\*1: When the same malfunction is detected in two consecutive trips, MIL will light up.

\*2: MIL will go off after vehicle is driven 3 times (pattern B) without any malfunctions.

\*3: When the same malfunction is detected in two consecutive trips, the DTC and the freeze frame data will be stored in ECM.

\*4: The DTC and the freeze frame data will not be displayed any longer after vehicle is driven 40 times (pattern A) without the same malfunction. (The DTC and the freeze frame data still remain in ECM.)

\*5: When a malfunction is detected for the first time, the 1st trip DTC

and the 1st trip freeze frame data will be stored in ECM.

\*6: 1st trip DTC will be cleared after vehicle is driven once (pattern B) without the same malfunction.

\*7: When the same malfunction is detected in the 2nd trip, the 1st trip freeze frame data will be cleared.

# ON BOARD DIAGNOSTIC SYSTEM DESCRIPTION

OBD System Operation Chart (Cont'd)

## EXPLANATION FOR DRIVING PATTERNS EXCEPT FOR "MISFIRE <EXHAUST QUALITY DETERIORATION>", "FUEL INJECTION SYSTEM"

### <Driving Pattern A>

NEEC0032908

NEEC003250601

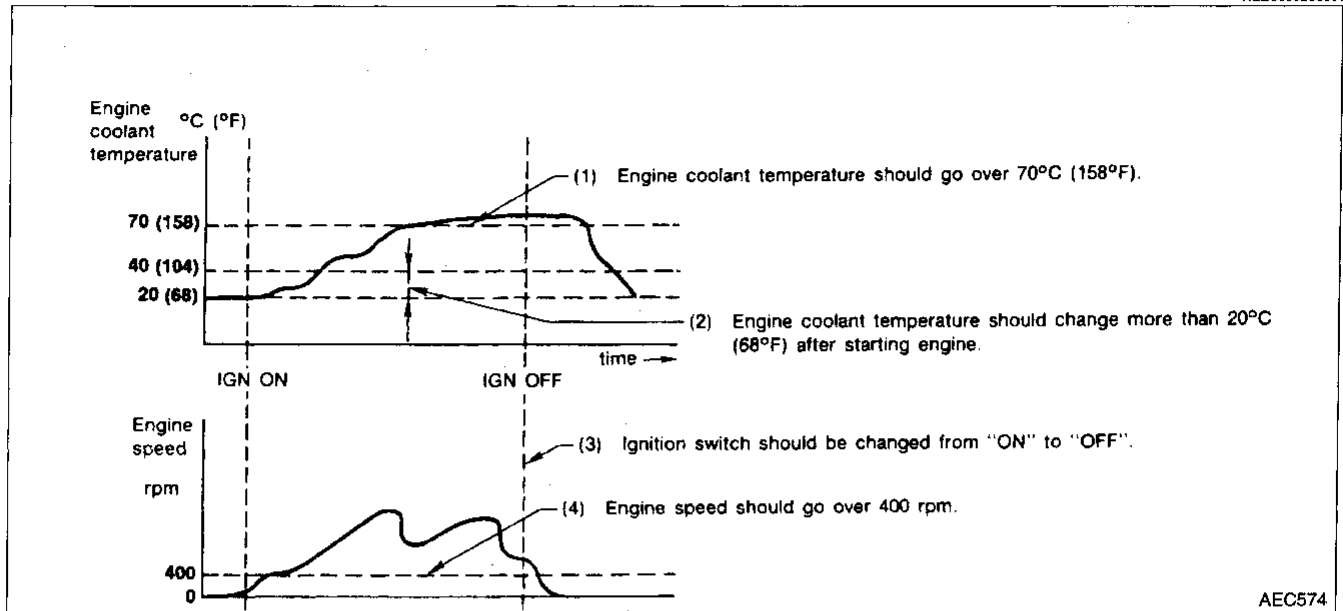

- The A counter will be cleared when the malfunction is detected regardless of (1) - (4).
- The A counter will be counted up when (1) - (4) are satisfied without the same malfunction.
- The DTC will not be displayed after the A counter reaches 40.

### <Driving Pattern B>

NEEC003250602

Driving pattern B means the vehicle operation as follows:

All components and systems should be monitored at least once by the OBD system.

- The B counter will be cleared when the malfunction is detected once regardless of the driving pattern.
- The B counter will be counted up when driving pattern B is satisfied without any malfunctions.
- The MIL will go off when the B counter reaches 3 (\*2 in "OBD SYSTEM OPERATION CHART").

GI  
MA  
EM  
LC  
EC  
FE  
CL  
MT  
AT  
TF  
PD  
FA  
RA  
BR  
ST  
RS  
BT  
HA  
EL  
IDX

# ON BOARD DIAGNOSTIC SYSTEM DESCRIPTION

## CONSULT

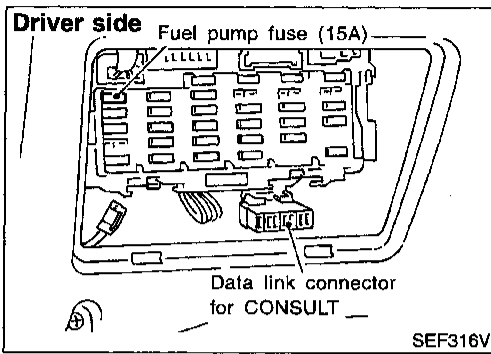

## CONSULT

### CONSULT INSPECTION PROCEDURE

=NEEC0039

NEEC0039S01

1. Turn ignition switch off.
2. Connect "CONSULT" to data link connector for CONSULT. (Data link connector for CONSULT is located behind the fuse box cover.)

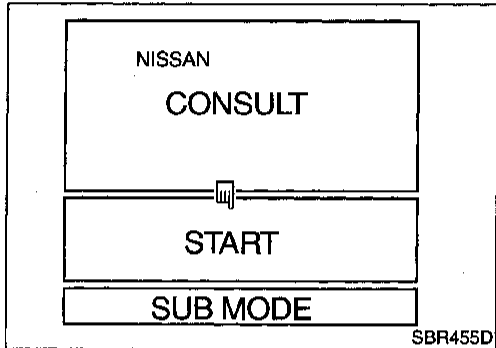

3. Turn ignition switch "ON".
4. Touch "START".

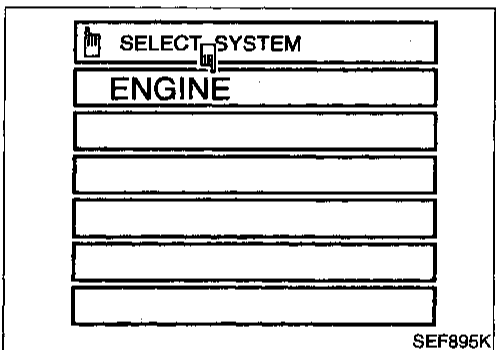

5. Touch "ENGINE".

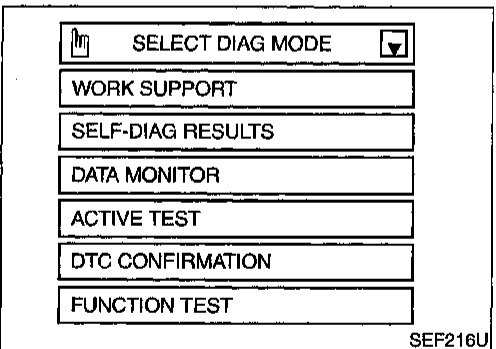

6. Perform each diagnostic test mode according to each service procedure.

**For further information, see the CONSULT Operation Manual. This sample shows the display when using the UE990 program card. Screen differs in accordance with the program card used.**

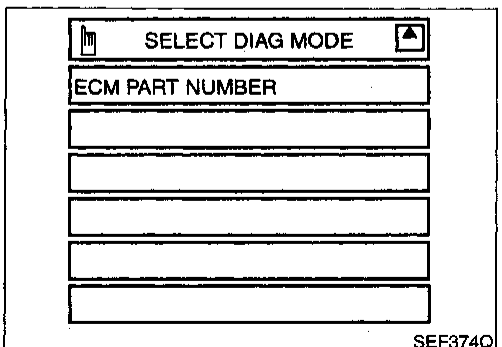



# ON BOARD DIAGNOSTIC SYSTEM DESCRIPTION

CONSULT (Cont'd)

## ENGINE CONTROL COMPONENT PARTS/CONTROL SYSTEMS APPLICATION

NEEC0033S02

Item		DIAGNOSTIC TEST MODE							
		WORK SUP-PORT	SELF-DIAGNOSTIC RESULTS		DATA MONI-TOR	ACTIVE TEST	DTC CONFIRMATION		FUNC-TION TEST
			DTC*1	FREEZE FRAME DATA*2			SRT STA-TUS	DTC WORK SUP-PORT	
ENGINE CONTROL COMPONENT PARTS INPUT	Camshaft position sensor		X	X	X				
	Mass air flow sensor		X		X				
	Engine coolant temperature sensor		X	X	X	X			
	Front heated oxygen sensor		X		X		X	X	X
	Rear heated oxygen sensor		X		X		X	X	
	Vehicle speed sensor		X	X	X				X
	Throttle position sensor	X	X		X				X
	Tank fuel temperature sensor		X		X	X			
	EVAP control system pressure sensor		X		X				
	Absolute pressure sensor		X		X				
	EGR temperature sensor		X		X				
	Intake air temperature sensor		X		X				
	Crankshaft position sensor (OBD)		X						
	Knock sensor		X						
	Ignition switch (start signal)				X				X
	Closed throttle position switch		X		X				
	Closed throttle position switch (throttle position sensor signal)				X				X
	Air conditioner switch				X				
	Park/neutral position (PNP) switch		X		X				X
	Power steering oil pressure switch				X				X
Battery voltage				X					
Ambient air temperature switch				X					

GI  
MA  
EM  
LC  
EC  
FE  
CL  
MT  
AT  
TF  
PD  
FA  
RA  
BR  
ST  
RS  
BT  
HA  
EL  
IDX

# ON BOARD DIAGNOSTIC SYSTEM DESCRIPTION

CONSULT (Cont'd)

Item		DIAGNOSTIC TEST MODE							
		WORK SUP-PORT	SELF-DIAGNOSTIC RESULTS		DATA MONITOR	ACTIVE TEST	DTC CONFIRMATION		FUNCTION TEST
			DTC*1	FREEZE FRAME DATA*2			SRT STATUS	DTC WORK SUP-PORT	
ENGINE CONTROL COMPONENT PARTS	OUTPUT	Injectors			X	X			X
	Power transistor (Ignition timing)		X (Ignition signal)		X	X			X
	IACV-AAC valve	X	X		X	X			X
	EVAP canister purge volume control solenoid valve		X		X	X		X	
	Air conditioner relay				X				
	Fuel pump relay	X			X	X			X
	Cooling fan		X		X	X			X
	EGRC-solenoid valve		X		X	X			X*3
	Front heated oxygen sensor heater		X		X		X		
	Rear heated oxygen sensor heater		X		X		X		
	EVAP canister vent control valve		X		X	X			
	Vacuum cut valve bypass valve		X		X	X		X	
	MAP/BARO switch solenoid valve		X		X	X			
	Calculated load value			X	X				

X: Applicable

\*1: This item includes 1st trip DTCs.

\*2: This mode includes 1st trip freeze frame data or freeze frame data. The items appear on CONSULT screen in freeze frame data mode only if a 1st trip DTC or DTC is detected. For details, refer to EC-46.

\*3: If this function test mode is not available, use the ACTIVE TEST mode.

# ON BOARD DIAGNOSTIC SYSTEM DESCRIPTION

CONSULT (Cont'd)

FUNCTION	
Diagnostic test mode	Function
Work support	This mode enables a technician to adjust some devices faster and more accurately by following the indications on the CONSULT unit.
Self-diagnostic results	Self-diagnostic results such as 1st trip DTC, DTCs and 1st trip freeze frame data or freeze frame data can be read and erased quickly.*1
Data monitor	Input/Output data in the ECM can be read.
Active test	Diagnostic Test Mode in which CONSULT drives some actuators apart from the ECMs and also shifts some parameters in a specified range.
DTC confirmation	The status of system monitoring tests and the self-diagnosis status/result can be confirmed.
Function test	Conducted by CONSULT instead of a technician to determine whether each system is "OK" or "NG".
ECM part number	ECM part number can be read.

\*1 The following emission-related diagnostic information is cleared when the ECM memory is erased.

- 1) Diagnostic trouble codes
- 2) 1st trip diagnostic trouble codes
- 3) Freeze frame data
- 4) 1st trip freeze frame data
- 5) System readiness test (SRT) codes
- 6) Test values
- 7) Others

## WORK SUPPORT MODE

WORK ITEM	CONDITION	USAGE
THRTL POS SEN ADJ	CHECK THE THROTTLE POSITION SENSOR SIGNAL. ADJUST IT TO THE SPECIFIED VALUE BY ROTATING THE SENSOR BODY UNDER THE FOLLOWING CONDITIONS. <ul style="list-style-type: none"> <li>• IGN SW "ON"</li> <li>• ENG NOT RUNNING</li> <li>• ACC PEDAL NOT PRESSED</li> </ul>	When adjusting throttle position sensor initial position
IACV-AAC VALVE ADJ	SET ENGINE SPEED AT THE SPECIFIED VALUE UNDER THE FOLLOWING CONDITIONS. <ul style="list-style-type: none"> <li>• ENGINE WARMED UP</li> <li>• NO-LOAD</li> </ul>	When adjusting initial ignition timing and idle speed
FUEL PRESSURE RELEASE	<ul style="list-style-type: none"> <li>• FUEL PUMP WILL STOP BY TOUCHING "START" DURING IDLING.</li> <li>• CRANK A FEW TIMES AFTER ENGINE STALLS.</li> </ul>	When releasing fuel pressure from fuel line

# ON BOARD DIAGNOSTIC SYSTEM DESCRIPTION

CONSULT (Cont'd)

WORK ITEM	CONDITION	USAGE
EVAP SYSTEM CLOSE	<p>OPEN THE VACUUM CUT VALVE BYPASS VALVE AND CLOSE THE EVAP CANISTER VENT CONTROL VALVE IN ORDER TO MAKE EVAP SYSTEM CLOSE UNDER THE FOLLOWING CONDITIONS.</p> <ul style="list-style-type: none"> <li>• IGN SW "ON"</li> <li>• ENGINE NOT RUNNING</li> <li>• AMBIENT TEMPERATURE IS ABOVE 0°C (32°F).</li> <li>• NO VACUUM AND NO HIGH PRESSURE IN EVAP SYSTEM</li> <li>• TANK FUEL TEMP. IS MORE THAN 0°C (32°F).</li> <li>• WITHIN 10 MINUTES AFTER STARTING "EVAP SYSTEM CLOSE"</li> <li>• WHEN TRYING TO EXECUTE "EVAP SYSTEM CLOSE" UNDER THE CONDITION EXCEPT ABOVE, CONSULT WILL DISCONTINUE IT AND DISPLAY APPROPRIATE INSTRUCTION.</li> </ul> <p><b>NOTE:</b>  <b>WHEN STARTING ENGINE, CONSULT MAY DISPLAY "BATTERY VOLTAGE IS LOW. CHARGE BATTERY", EVEN IN USING CHARGED BATTERY.</b></p>	When detecting EVAP vapor leak point of EVAP system

## SELF-DIAGNOSTIC MODE

### DTC and 1st Trip DTC

Regarding items of "DTC and 1st trip DTC", refer to "TROUBLE DIAGNOSIS — INDEX" (See EC-2.)

### Freeze Frame Data and 1st Trip Freeze Frame Data

Freeze frame data item*1	Description
DIAG TROUBLE CODE [PXXXX]	<ul style="list-style-type: none"> <li>• The engine control component part/control system has a trouble code, it is displayed as "PXXXX". (Refer to "TROUBLE DIAGNOSIS — INDEX", EC-2.)</li> </ul>
FUEL SYS-B1*2	<ul style="list-style-type: none"> <li>• "Fuel injection system status" at the moment a malfunction is detected is displayed.</li> <li>• One mode in the following is displayed.  "MODE 2": Open loop due to detected system malfunction  "MODE 3": Open loop due to driving conditions (power enrichment, deceleration enrichment)  "MODE 4": Closed loop - using oxygen sensor(s) as feedback for fuel control  "MODE 5": Open loop - has not yet satisfied condition to go to closed loop</li> </ul>
FUEL SYS-B2*2	<ul style="list-style-type: none"> <li>• The engine coolant temperature at the moment a malfunction is detected is displayed.</li> </ul>
CAL/LD VALUE [%]	<ul style="list-style-type: none"> <li>• The calculated load value at the moment a malfunction is detected is displayed.</li> </ul>
COOLANT TEMP [°C] or [°F]	<ul style="list-style-type: none"> <li>• The engine coolant temperature at the moment a malfunction is detected is displayed.</li> </ul>
S-FUEL TRIM-B1 [%]	<ul style="list-style-type: none"> <li>• "Short-term fuel trim" at the moment a malfunction is detected is displayed.</li> <li>• The short-term fuel trim indicates dynamic or instantaneous feedback compensation to the base fuel schedule.</li> </ul>
S-FUEL TRIM-B2 [%]	<ul style="list-style-type: none"> <li>• "Long-term fuel trim" at the moment a malfunction is detected is displayed.</li> <li>• The long-term fuel trim indicates much more gradual feedback compensation to the base fuel schedule than short-term fuel trim.</li> </ul>
L-FUEL TRIM-B1 [%]	<ul style="list-style-type: none"> <li>• The engine speed at the moment a malfunction is detected is displayed.</li> </ul>
L-FUEL TRIM-B2 [%]	<ul style="list-style-type: none"> <li>• The vehicle speed at the moment a malfunction is detected is displayed.</li> </ul>
ENGINE SPEED [rpm]	<ul style="list-style-type: none"> <li>• The absolute pressure at the moment a malfunction is detected is displayed.</li> </ul>
VHCL SPEED [km/h] or [mph]	<ul style="list-style-type: none"> <li>• The absolute pressure at the moment a malfunction is detected is displayed.</li> </ul>
ABSOL PRESS [kPa] or [kg/cm <sup>2</sup> ] or [psi]	<ul style="list-style-type: none"> <li>• The absolute pressure at the moment a malfunction is detected is displayed.</li> </ul>

\*1: The items are the same as those of 1st trip freeze frame data.

\*2: Regarding D22 model, "-B1" indicates right bank and "-B2" indicates left bank.

# ON BOARD DIAGNOSTIC SYSTEM DESCRIPTION

CONSULT (Cont'd)

## DATA MONITOR MODE

=NEEC0033506

Monitored item [Unit]	ECM input signals	Main signals	Description	Remarks
CMPS-RPM (POS) [rpm]	○	○	<ul style="list-style-type: none"> <li>Indicates the engine speed computed from the POS signal (1° signal) of the camshaft position sensor.</li> </ul>	
CMPS-RPM (REF) [rpm]	○		<ul style="list-style-type: none"> <li>Indicates the engine speed computed from the REF signal (120° signal) of the camshaft position sensor.</li> </ul>	
MAS AIR/FL SE [V]	○	○	<ul style="list-style-type: none"> <li>The signal voltage of the mass air flow sensor is displayed.</li> </ul>	<ul style="list-style-type: none"> <li>When the engine is stopped, a certain value is indicated.</li> </ul>
COOLAN TEMP/S [°C] or [°F]	○	○	<ul style="list-style-type: none"> <li>The engine coolant temperature (determined by the signal voltage of the engine coolant temperature sensor) is displayed.</li> </ul>	<ul style="list-style-type: none"> <li>When the engine coolant temperature sensor is open or short-circuited, ECM enters fail-safe mode. The engine coolant temperature determined by the ECM is displayed.</li> </ul>
FR O2 SEN-B2 [V]	○	○	<ul style="list-style-type: none"> <li>The signal voltage of the front heated oxygen sensor is displayed.</li> </ul>	
FR O2 SEN-B1 [V]	○			
RR O2 SEN-B1 [V]	○	○	<ul style="list-style-type: none"> <li>The signal voltage of the rear heated oxygen sensor is displayed.</li> </ul>	
RR O2 SEN-B2 [V]	○			
FR O2 MNTR-B2 [RICH/LEAN]	○	○	<ul style="list-style-type: none"> <li>Display of front heated oxygen sensor signal during air-fuel ratio feedback control: RICH ... means the mixture became "rich", and control is being affected toward a leaner mixture. LEAN ... means the mixture became "lean", and control is being affected toward a rich mixture.</li> </ul>	<ul style="list-style-type: none"> <li>After turning ON the ignition switch, "RICH" is displayed until air-fuel mixture ratio feedback control begins.</li> <li>When the air-fuel ratio feedback is clamped, the value just before the clamping is displayed continuously.</li> </ul>
FR O2 MNTR-B1 [RICH/LEAN]	○	○		
RR O2 MNTR-B1 [RICH/LEAN]	○		<ul style="list-style-type: none"> <li>Display of rear heated oxygen sensor signal: RICH ... means the amount of oxygen after three way catalyst is relatively small. LEAN ... means the amount of oxygen after three way catalyst is relatively large.</li> </ul>	<ul style="list-style-type: none"> <li>When the engine is stopped, a certain value is indicated.</li> </ul>
RR O2 MNTR-B2 [RICH/LEAN]	○	○		
VHCL SPEED SE [km/h] or [mph]	○	○	<ul style="list-style-type: none"> <li>The vehicle speed computed from the vehicle speed sensor signal is displayed.</li> </ul>	
BATTERY VOLT [V]	○	○	<ul style="list-style-type: none"> <li>The power supply voltage of ECM is displayed.</li> </ul>	
THRTL POS SEN [V]	○	○	<ul style="list-style-type: none"> <li>The throttle position sensor signal voltage is displayed.</li> </ul>	
TANK F/TMP SE [°C] or [°F]	○		<ul style="list-style-type: none"> <li>The fuel temperature judged from the tank fuel temperature sensor signal voltage is displayed.</li> </ul>	
EGR TEMP SEN [V]	○		<ul style="list-style-type: none"> <li>The signal voltage of the EGR temperature sensor is displayed.</li> </ul>	
INT/A TEMP SE [°C] or [°F]	○		<ul style="list-style-type: none"> <li>The intake air temperature determined by the signal voltage of the intake air temperature sensor is indicated.</li> </ul>	

GI  
 MA  
 EM  
 LC  
**EC**  
 FE  
 CL  
 MT  
 AT  
 TF  
 PD  
 FA  
 RA  
 BR  
 ST  
 RS  
 BT  
 HA  
 EL  
 IDX

## ON BOARD DIAGNOSTIC SYSTEM DESCRIPTION

CONSULT (Cont'd)

Monitored item [Unit]	ECM input signals	Main signals	Description	Remarks
START SIGNAL [ON/OFF]	○	○	<ul style="list-style-type: none"> <li>Indicates [ON/OFF] condition from the starter signal.</li> </ul>	<ul style="list-style-type: none"> <li>After starting the engine, [OFF] is displayed regardless of the starter signal.</li> </ul>
CLSD THL/P SW [ON/OFF]			<ul style="list-style-type: none"> <li>Indicates mechanical contact [ON/OFF] condition of the closed throttle position switch.</li> </ul>	
CLSD THL POS [ON/OFF]	○	○	<ul style="list-style-type: none"> <li>Indicates idle position [ON/OFF] computed by ECM according to the throttle position sensor signal.</li> </ul>	
AIR COND SIG [ON/OFF]	○	○	<ul style="list-style-type: none"> <li>Indicates [ON/OFF] condition of the air conditioner switch as determined by the air conditioner signal.</li> </ul>	
P/N POSI SW [ON/OFF]	○	○	<ul style="list-style-type: none"> <li>Indicates [ON/OFF] condition from the park/neutral position (PNP) switch signal.</li> </ul>	
PW/ST SIGNAL [ON/OFF]	○	○	<ul style="list-style-type: none"> <li>[ON/OFF] condition of the power steering oil pressure switch determined by the power steering oil pressure signal is indicated.</li> </ul>	
AMB TEMP SW [ON/OFF]	○	○	<ul style="list-style-type: none"> <li>Indicates [ON/OFF] condition from the ambient air temperature switch signal.</li> </ul>	
IGNITION SW [ON/OFF]	○		<ul style="list-style-type: none"> <li>Indicates [ON/OFF] condition from ignition switch.</li> </ul>	
INJ PULSE-B2 [msec]		○	<ul style="list-style-type: none"> <li>Indicates the actual fuel injection pulse width compensated by ECM according to the input signals.</li> </ul>	<ul style="list-style-type: none"> <li>When the engine is stopped, a certain computed value is indicated.</li> </ul>
INJ PULSE-B1 [msec]				
B/FUEL SCHDL [msec]		○	<ul style="list-style-type: none"> <li>"Base fuel schedule" indicates the fuel injection pulse width programmed into ECM, prior to any learned on board correction.</li> </ul>	
IGN TIMING [BTDC]		○	<ul style="list-style-type: none"> <li>Indicates the ignition timing computed by ECM according to the input signals.</li> </ul>	<ul style="list-style-type: none"> <li>When the engine is stopped, a certain value is indicated.</li> </ul>
IACV-AAC/V [%]		○	<ul style="list-style-type: none"> <li>Indicates the IACV-AAC valve control value computed by ECM according to the input signals.</li> </ul>	
PURG VOL C/V [%]		○	<ul style="list-style-type: none"> <li>Indicates the EVAP canister purge volume control solenoid valve control value computed by the ECM according to the input signals.</li> <li>The opening becomes larger as the value increases.</li> </ul>	
A/F ALPHA-B2 [%]			<ul style="list-style-type: none"> <li>The mean value of the air-fuel ratio feedback correction factor per cycle is indicated.</li> </ul>	<ul style="list-style-type: none"> <li>When the engine is stopped, a certain value is indicated.</li> <li>This data also includes the data for the air-fuel ratio learning control.</li> </ul>
A/F ALPHA-B1 [%]				
EVAP SYS PRES [V]			<ul style="list-style-type: none"> <li>The signal voltage of EVAP control system pressure sensor is displayed.</li> </ul>	
AIR COND RLY [ON/OFF]			<ul style="list-style-type: none"> <li>The air conditioner relay control condition (determined by ECM according to the input signal) is indicated.</li> </ul>	

# ON BOARD DIAGNOSTIC SYSTEM DESCRIPTION

CONSULT (Cont'd)

Monitored item [Unit]	ECM input signals	Main signals	Description	Remarks
FUEL PUMP RLY [ON/OFF]			<ul style="list-style-type: none"> <li>Indicates the fuel pump relay control condition determined by ECM according to the input signals.</li> </ul>	
COOLING FAN [ON/OFF]			<ul style="list-style-type: none"> <li>Indicates the control condition of the cooling fan (determined by ECM according to the input signal). ON ... Operation OFF ... Stop</li> </ul>	
EGRC SOL/V [ON/OFF] (FLOW/CUT)			<ul style="list-style-type: none"> <li>The control condition of the EGRC-solenoid valve (determined by ECM according to the input signal) is indicated.</li> <li>ON ... EGR is operational OFF ... EGR operation is cut-off</li> </ul>	
VENT CONT/V [ON/OFF]			<ul style="list-style-type: none"> <li>The control condition of the EVAP canister vent control valve (determined by ECM according to the input signal) is indicated.</li> <li>ON ... Closed OFF ... Open</li> </ul>	
FR O2 HTR-B1 [ON/OFF]			<ul style="list-style-type: none"> <li>Indicates [ON/OFF] condition of front heated oxygen sensor heater determined by ECM according to the input signals.</li> </ul>	
FR O2 HTR-B2 [ON/OFF]				
RR O2 HTR-B1 [ON/OFF]			<ul style="list-style-type: none"> <li>Indicates [ON/OFF] condition of rear heated oxygen sensor heater determined by ECM according to the input signals.</li> </ul>	
RR O2 HTR-B2 [ON/OFF]				
VCV BYPASS/V [ON/OFF]			<ul style="list-style-type: none"> <li>The control condition of the vacuum cut valve bypass valve (determined by ECM according to the input signal) is indicated.</li> <li>ON ... Open OFF ... Closed</li> </ul>	
CAL/LD VALUE [%]			<ul style="list-style-type: none"> <li>"Calculated load value" indicates the value of the current airflow divided by peak airflow.</li> </ul>	
ABSOL TH-P/S [%]			<ul style="list-style-type: none"> <li>"Absolute throttle position sensor" indicates the throttle opening computed by ECM according to the signal voltage of the throttle position sensor.</li> </ul>	
MASS AIRFLOW [g·m/s]			<ul style="list-style-type: none"> <li>Indicates the mass airflow computed by ECM according to the signal voltage of the mass airflow sensor.</li> </ul>	
MAP/BARO SW/V [MAP/BARO]			<ul style="list-style-type: none"> <li>The control condition of the MAP/BARO switch solenoid valve (determined by ECM according to the input signal) is indicated. MAP ... Intake manifold absolute pressure BARO ... Ambient air barometric pressure</li> </ul>	

# ON BOARD DIAGNOSTIC SYSTEM DESCRIPTION

CONSULT (Cont'd)

Monitored item [Unit]	ECM input signals	Main signals	Description	Remarks
ABSOL PRES/SE [V]			<ul style="list-style-type: none"> <li>The signal voltage of the absolute pressure sensor is displayed.</li> </ul>	
VOLTAGE [V]			<ul style="list-style-type: none"> <li>Voltage measured by the voltage probe.</li> </ul>	
PULSE [msec] or [Hz] or [%]			<ul style="list-style-type: none"> <li>Pulse width, frequency or duty cycle measured by the pulse probe.</li> </ul>	<ul style="list-style-type: none"> <li>Only “#” is displayed if item is unable to be measured.</li> <li>Figures with “#’s are temporary ones. They are the same figures as an actual piece of data which was just previously measured.</li> </ul>

**NOTE:**

- Any monitored item that does not match the vehicle being diagnosed is deleted from the display automatically.
- Regarding D22 model, “-B1” indicates right bank and “-B2” indicates left bank.

## ACTIVE TEST MODE

NEEC0033S07

TEST ITEM	CONDITION	JUDGEMENT	CHECK ITEM (REMEDY)
FUEL INJECTION	<ul style="list-style-type: none"> <li>Engine: Return to the original trouble condition</li> <li>Change the amount of fuel injection using CONSULT.</li> </ul>	If trouble symptom disappears, see CHECK ITEM.	<ul style="list-style-type: none"> <li>Harness and connector</li> <li>Fuel injectors</li> <li>Front heated oxygen sensor</li> </ul>
IACV-AAC/V OPENING	<ul style="list-style-type: none"> <li>Engine: After warming up, idle the engine.</li> <li>Change the IACV-AAC valve opening percent using CONSULT.</li> </ul>	Engine speed changes according to the opening percent.	<ul style="list-style-type: none"> <li>Harness and connector</li> <li>IACV-AAC valve</li> </ul>
ENG COOLANT TEMP	<ul style="list-style-type: none"> <li>Engine: Return to the original trouble condition</li> <li>Change the engine coolant temperature using CONSULT.</li> </ul>	If trouble symptom disappears, see CHECK ITEM.	<ul style="list-style-type: none"> <li>Harness and connector</li> <li>Engine coolant temperature sensor</li> <li>Fuel injectors</li> </ul>
IGNITION TIMING	<ul style="list-style-type: none"> <li>Engine: Return to the original trouble condition</li> <li>Timing light: Set</li> <li>Retard the ignition timing using CONSULT.</li> </ul>	If trouble symptom disappears, see CHECK ITEM.	<ul style="list-style-type: none"> <li>Adjust initial ignition timing</li> </ul>
POWER BALANCE	<ul style="list-style-type: none"> <li>Engine: After warming up, idle the engine.</li> <li>A/C switch “OFF”</li> <li>Shift lever “N”</li> <li>Cut off each injector signal one at a time using CONSULT.</li> </ul>	Engine runs rough or dies.	<ul style="list-style-type: none"> <li>Harness and connector</li> <li>Compression</li> <li>Injectors</li> <li>Power transistor</li> <li>Spark plugs</li> <li>Ignition coils</li> </ul>
COOLING FAN	<ul style="list-style-type: none"> <li>Ignition switch: ON</li> <li>Turn the cooling fan “ON” and “OFF” using CONSULT.</li> </ul>	Cooling fan moves and stops.	<ul style="list-style-type: none"> <li>Harness and connector</li> <li>Cooling fan motor</li> <li>Cooling fan relay</li> </ul>
FUEL PUMP RELAY	<ul style="list-style-type: none"> <li>Ignition switch: ON (Engine stopped)</li> <li>Turn the fuel pump relay “ON” and “OFF” using CONSULT and listen to operating sound.</li> </ul>	Fuel pump relay makes the operating sound.	<ul style="list-style-type: none"> <li>Harness and connector</li> <li>Fuel pump relay</li> </ul>
EGRC SOLENOID VALVE	<ul style="list-style-type: none"> <li>Ignition switch: ON (Engine stopped)</li> <li>Turn solenoid valve “ON” and “OFF” with the CONSULT and listen to operating sound.</li> </ul>	Solenoid valve makes an operating sound.	<ul style="list-style-type: none"> <li>Harness and connector</li> <li>Solenoid valve</li> </ul>



# ON BOARD DIAGNOSTIC SYSTEM DESCRIPTION

CONSULT (Cont'd)

TEST ITEM	CONDITION	JUDGEMENT	CHECK ITEM (REMEDY)
SELF-LEARNING CONT	<ul style="list-style-type: none"> <li>In this test, the coefficient of self-learning control mixture ratio returns to the original coefficient by touching "CLEAR" on the screen.</li> </ul>		
PURG VOL CONT/V	<ul style="list-style-type: none"> <li>Engine: After warming up, run engine at 1,500 rpm.</li> <li>Change the EVAP canister purge volume control solenoid valve opening percent using CONSULT.</li> </ul>	Engine speed changes according to the opening percent.	<ul style="list-style-type: none"> <li>Harness and connector</li> <li>Solenoid valve</li> </ul>
TANK F/TEMP SEN	<ul style="list-style-type: none"> <li>Change the tank fuel temperature using CONSULT.</li> </ul>		
VENT CONTROL/V	<ul style="list-style-type: none"> <li>Ignition switch: ON (Engine stopped)</li> <li>Turn solenoid valve "ON" and "OFF" with the CONSULT and listen to operating sound.</li> </ul>	Solenoid valve makes an operating sound.	<ul style="list-style-type: none"> <li>Harness and connector</li> <li>Solenoid valve</li> </ul>
VC/V BYPASS/V	<ul style="list-style-type: none"> <li>Ignition switch: ON (Engine stopped)</li> <li>Turn solenoid valve "ON" and "OFF" with the CONSULT and listen to operating sound.</li> </ul>	Solenoid valve makes an operating sound.	<ul style="list-style-type: none"> <li>Harness and connector</li> <li>Solenoid valve</li> </ul>
MAP/BARO SW/V	<ul style="list-style-type: none"> <li>Ignition switch: ON (Engine stopped)</li> <li>Turn the MAP/BARO switch solenoid valve between "MAP" and "BARO" using CONSULT and listen to operating sound.</li> </ul>	Solenoid valve makes an operating sound.	<ul style="list-style-type: none"> <li>Harness and connector</li> <li>Solenoid valve</li> </ul>

## DTC CONFIRMATION MODE

### SRT STATUS Mode

For details, refer to "SYSTEM READINESS TEST (SRT) CODE", EC-46.

NEEC0033S10

NEEC0033S1001

GI  
MA  
EM  
LC  
EC  
FE  
CL  
MT  
AT  
TF  
PD  
FA  
RA  
BR  
ST  
RS  
BT  
HA  
EL  
IDX

# ON BOARD DIAGNOSTIC SYSTEM DESCRIPTION

CONSULT (Cont'd)

## DTC Work Support Mode

NEEC0033S1002

Test mode	Test item	Condition	Reference page
EVAPORATIVE SYSTEM	EVAP SML LEAK P0440	Refer to corresponding trouble diagnosis for DTC.	EC-303
	EVAP SML LEAK P1440		EC-395
	PURG VOL CNV P1444		EC-402
	PURGE FLOW P1447		EC-414
	VC CUT/V BP/V P1491		EC-432
FR O2 SENSOR	FR O2 SEN-B1 P0130		EC-166
	FR O2 SEN-B1 P0131		EC-174
	FR O2 SEN-B1 P0132		EC-180
	FR O2 SEN-B1 P0133		EC-186
	FR O2 SEN-B2 P0150		EC-166
	FR O2 SEN-B2 P0151		EC-174
	FR O2 SEN-B2 P0152		EC-180
	FR O2 SEN-B2 P0153		EC-186
RR O2 SENSOR	RR O2 SEN-B1 P0137		EC-208
	RR O2 SEN-B1 P0138		EC-217
	RR O2 SEN-B1 P0139		EC-225
	RR O2 SEN-B2 P0157		EC-208
	RR O2 SEN-B2 P0158		EC-217
	RR O2 SEN-B2 P0159		EC-225
EGR SYSTEM	EGR SYSTEM P0400		EC-288
	EGRC-BPT/VLV P0402	EC-296	
	EGR SYSTEM P1402	EC-389	

## FUNCTION TEST MODE

NEEC0033S008

FUNCTION TEST ITEM	CONDITION	JUDGEMENT		CHECK ITEM (REMEDY)
SELF-DIAG RESULTS	<ul style="list-style-type: none"> <li>Ignition switch: ON (Engine stopped)</li> <li>Displays the results of on board diagnostic system.</li> </ul>	—		Objective system
CLOSED THROTTLE POSI	<ul style="list-style-type: none"> <li>Ignition switch: ON (Engine stopped)</li> <li>Throttle position sensor circuit is tested when throttle is opened and closed fully. ("IDLE POSITION" is the test item name for the vehicles in which idle is selected by throttle position sensor.)</li> </ul>	Throttle valve: opened	OFF	<ul style="list-style-type: none"> <li>Harness and connector</li> <li>Throttle position sensor (Closed throttle position)</li> <li>Throttle position sensor (Closed throttle position) adjustment</li> <li>Throttle linkage</li> <li>Verify operation in DATA MONITOR mode.</li> </ul>
		Throttle valve: closed	ON	

# ON BOARD DIAGNOSTIC SYSTEM DESCRIPTION

CONSULT (Cont'd)

FUNCTION TEST ITEM	CONDITION	JUDGEMENT		CHECK ITEM (REMEDY)
THROTTLE POSITION CKT	<ul style="list-style-type: none"> <li>Ignition switch: ON (Engine stopped)</li> <li>Throttle position sensor circuit is tested when throttle is opened and closed fully.</li> </ul>	Range (Throttle valve fully opened — Throttle valve fully closed)	More than 3.0V	<ul style="list-style-type: none"> <li>Harness and connector</li> <li>Throttle position sensor</li> <li>Throttle position sensor adjustment</li> <li>Throttle linkage</li> <li>Verify operation in DATA MONITOR mode.</li> </ul>
PARK/NEUT POSITION SW CKT	<ul style="list-style-type: none"> <li>Ignition switch: ON (Engine stopped)</li> <li>PNP switch circuit is tested when shift lever is manipulated.</li> </ul>	Out of N/P positions	OFF	<ul style="list-style-type: none"> <li>Harness and connector</li> <li>PNP switch</li> <li>Linkage or PNP switch adjustment</li> </ul>
		In N/P positions	ON	
FUEL PUMP CIRCUIT	<ul style="list-style-type: none"> <li>Ignition switch: ON (Engine stopped)</li> <li>Fuel pump circuit is tested by checking the pulsation in fuel pressure when fuel tube is pinched.</li> </ul>	There is pressure pulsation on the fuel feed hose.		<ul style="list-style-type: none"> <li>Harness and connector</li> <li>Fuel pump</li> <li>Fuel pump relay</li> <li>Fuel filter clogging</li> <li>Fuel level</li> </ul>
EGRC SOL/V CIRCUIT*	<ul style="list-style-type: none"> <li>Ignition switch: ON (Engine stopped)</li> <li>EGRC-solenoid valve circuit is tested by checking solenoid valve operating noise.</li> </ul>	The solenoid valve makes an operating sound every 3 seconds.		<ul style="list-style-type: none"> <li>Harness and connector</li> <li>EGRC-solenoid valve</li> </ul>
COOLING FAN CIRCUIT	<ul style="list-style-type: none"> <li>Ignition switch: ON (Engine stopped)</li> <li>Cooling fan circuit is tested when cooling fan is rotated.</li> </ul>	The cooling fan rotates and stops every 3 seconds.		<ul style="list-style-type: none"> <li>Harness and connector</li> <li>Cooling fan motor</li> <li>Cooling fan relay</li> </ul>
START SIGNAL CIRCUIT	<ul style="list-style-type: none"> <li>Ignition switch: ON → START</li> <li>Start signal circuit is tested when engine is started by operating the starter. Battery voltage and engine coolant temperature before cranking, and average battery voltage, mass air flow sensor output voltage and cranking speed during cranking are displayed.</li> </ul>	Start signal: OFF → ON		<ul style="list-style-type: none"> <li>Harness and connector</li> <li>Ignition switch</li> </ul>
PW/ST SIGNAL CIRCUIT	<ul style="list-style-type: none"> <li>Ignition switch: ON (Engine running)</li> <li>Power steering oil pressure switch circuit is tested when steering wheel is rotated fully and then set to a straight line running position.</li> </ul>	Locked position	ON	<ul style="list-style-type: none"> <li>Harness and connector</li> <li>Power steering oil pressure switch</li> <li>Power steering oil pump</li> </ul>
		Neutral position	OFF	
VEHICLE SPEED SEN CKT	<ul style="list-style-type: none"> <li>Vehicle speed sensor circuit is tested when vehicle is running at a speed of 10 km/h (6 MPH) or higher.</li> </ul>	Vehicle speed sensor input signal is greater than 4 km/h (2 MPH)		<ul style="list-style-type: none"> <li>Harness and connector</li> <li>Vehicle speed sensor</li> <li>Speedometer</li> </ul>
IGN TIMING ADJ	<ul style="list-style-type: none"> <li>After warming up, idle the engine.</li> <li>Ignition timing is checked by reading ignition timing with a timing light and checking whether it agrees with specifications.</li> </ul>	The timing light indicates the same value on the screen.		<ul style="list-style-type: none"> <li>Adjust ignition timing (by moving camshaft position sensor or distributor)</li> <li>Camshaft position sensor drive mechanism</li> </ul>

GI  
MA  
EM  
LC  
**EC**  
FE  
CL  
MT  
AT  
TF  
PD  
FA  
RA  
BR  
ST  
RS  
BT  
HA  
EL  
IDX

# ON BOARD DIAGNOSTIC SYSTEM DESCRIPTION

CONSULT (Cont'd)

FUNCTION TEST ITEM	CONDITION	JUDGEMENT	CHECK ITEM (REMEDY)
MIXTURE RATIO TEST	<ul style="list-style-type: none"> <li>Air-fuel ratio feedback circuit (injection system, ignition system, vacuum system, etc.) is tested by examining the front heated oxygen sensor output at 2,000 rpm under non-loaded state.</li> </ul>	Front heated oxygen sensor COUNT: More than 5 times during 10 seconds	<ul style="list-style-type: none"> <li>INJECTION SYSTEM (Injector, fuel pressure regulator, harness or connector)</li> <li>IGNITION SYSTEM (Spark plug, power transistor, ignition coil, harness or connector)</li> <li>VACUUM SYSTEM (Intake air leaks)</li> <li>Front heated oxygen sensor circuit</li> <li>Front heated oxygen sensor operation</li> <li>Fuel pressure high or low</li> <li>Mass air flow sensor</li> </ul>
POWER BALANCE	<ul style="list-style-type: none"> <li>After warming up, idle the engine.</li> <li>Injector operation of each cylinder is stopped one after another, and resultant change in engine rotation is examined to evaluate combustion of each cylinder. (This is only displayed for models where a sequential multiport fuel injection system is used.)</li> </ul>	Difference in engine speed is greater than 25 rpm before and after cutting off the injector of each cylinder.	<ul style="list-style-type: none"> <li>Injector circuit (Injector, harness or connector)</li> <li>Ignition circuit (Spark plug, ignition coil with power transistor harness or connector)</li> <li>Compression</li> <li>Valve timing</li> </ul>
IACV-AAC/V SYSTEM	<ul style="list-style-type: none"> <li>After warming up, idle the engine.</li> <li>IACV-AAC valve system is tested by detecting change in engine speed when IACV-AAC valve opening is changed to 0%, 20% and 80%.</li> </ul>	Difference in engine speed is greater than 150 rpm between when valve opening is at 80% and 20%.	<ul style="list-style-type: none"> <li>Harness and connector</li> <li>IACV-AAC valve</li> <li>Air passage restriction between air inlet and IACV-AAC valve</li> <li>IAS (Idle adjusting screw) adjustment</li> </ul>

\*: If this function test mode is not available, use the ACTIVE TEST mode.

## REAL TIME DIAGNOSIS IN DATA MONITOR MODE (RECORDING VEHICLE DATA)

NEEC0033509

CONSULT has two kinds of triggers and they can be selected by touching "SETTING" in "DATA MONITOR" mode.

1) "AUTO TRIG" (Automatic trigger):

- The malfunction will be identified on the CONSULT screen in real time.

In other words, DTC/1st trip DTC and malfunction item will be displayed at the moment the malfunction is detected by ECM. DATA MONITOR can be performed continuously until a malfunction is detected. However, DATA MONITOR cannot continue any longer after the malfunction detection.

2) "MANU TRIG" (Manual trigger):

- DTC/1st trip DTC and malfunction item will not be displayed automatically on CONSULT screen even though a malfunction is detected by ECM.

DATA MONITOR can be performed continuously even though a malfunction is detected.

Use these triggers as follows:

1) "AUTO TRIG"

- While trying to detect the DTC/1st trip DTC by performing the "DTC Confirmation Procedure", be sure to select to "DATA MONITOR (AUTO TRIG)" mode. You can confirm the malfunction at the moment it is detected.
- While narrowing down the possible causes, CONSULT should

# ON BOARD DIAGNOSTIC SYSTEM DESCRIPTION

CONSULT (Cont'd)

be set in "DATA MONITOR (AUTO TRIG)" mode, especially in case the incident is intermittent.

When you are inspecting the circuit by gently shaking (or twisting) the suspicious connectors, components and harness in the "DTC Confirmation Procedure", the moment a malfunction is found the DTC/1st trip DTC will be displayed. (Refer to GI section, "Incident Simulation Tests" in "HOW TO PERFORM EFFICIENT DIAGNOSIS FOR AN ELECTRICAL INCIDENT".)

2) "MANU TRIG"

- If the malfunction is displayed as soon as "DATA MONITOR" is selected, reset CONSULT to "MANU TRIG". By selecting "MANU TRIG" you can monitor and store the data. The data can be utilized for further diagnosis, such as a comparison with the value for the normal operating condition.

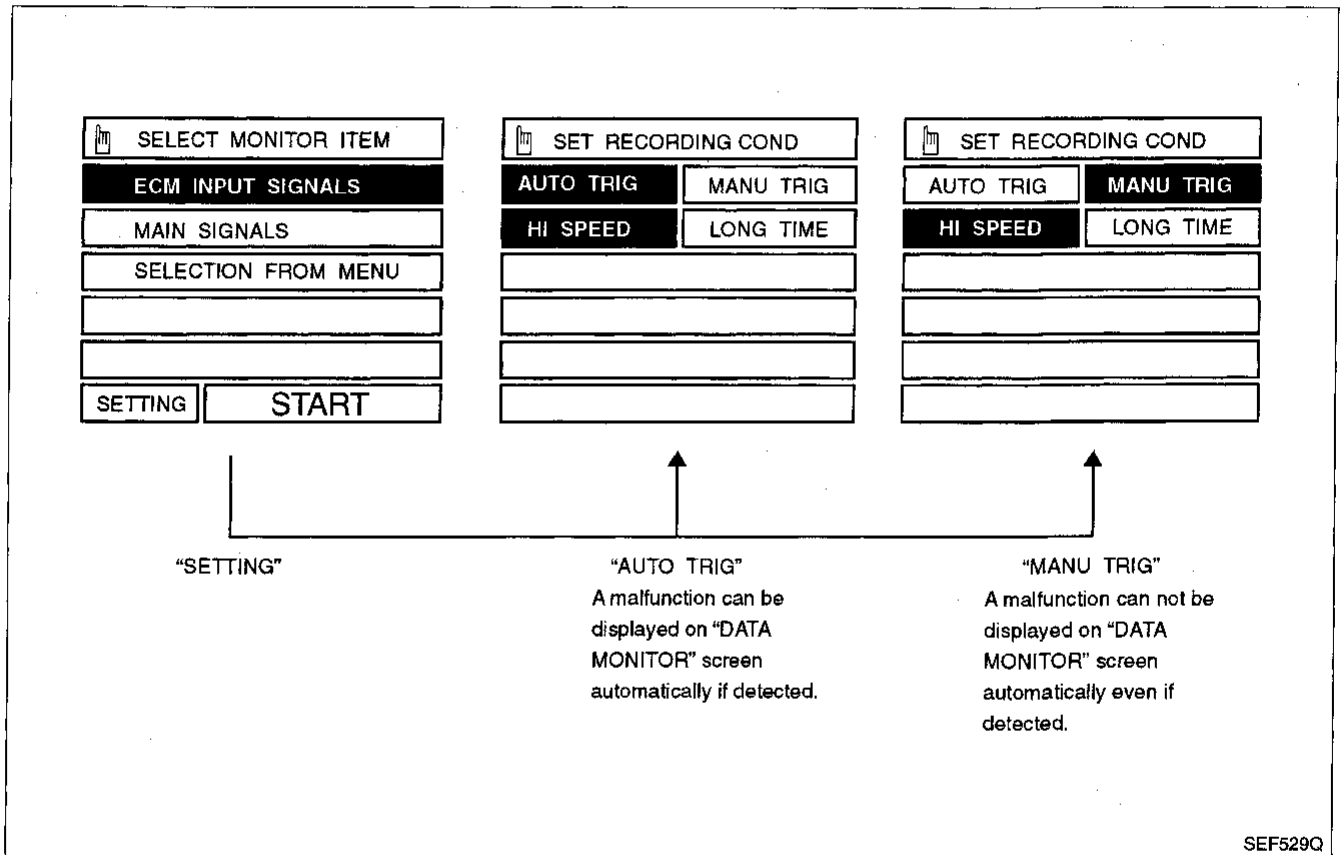

GI  
MA  
EM  
LC  
EC  
FE  
CL  
MT  
AT  
TF  
PD  
FA  
RA  
BR  
ST  
RS  
BT  
HA  
EL  
IDX

# ON BOARD DIAGNOSTIC SYSTEM DESCRIPTION

## Generic Scan Tool (GST)

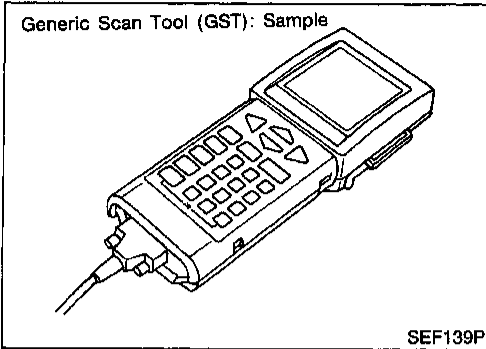

## Generic Scan Tool (GST) DESCRIPTION

-NEEC0034

NEEC0034S01

Generic Scan Tool (OBDII scan tool) complying with SAE J1978 has 7 different functions explained on the next page. ISO9141 is used as the protocol. The name "GST" or "Generic Scan Tool" is used in this service manual.

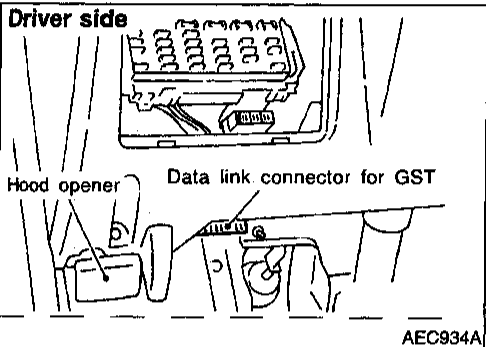

## GST INSPECTION PROCEDURE

NEEC0034S02

1. Turn ignition switch OFF.
2. Connect "GST" to data link connector for GST. (Data link connector for GST is located under LH dash panel near the fuse box cover.)
3. Turn ignition switch ON.
4. Enter the program according to instruction on the screen or in the operation manual.

(\*: Regarding GST screens in this section, sample screens are shown.)

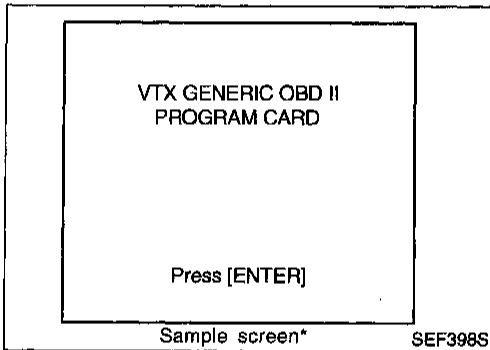

5. Perform each diagnostic mode according to each service procedure.

**For further information, see the GST Operation Manual of the tool maker.**

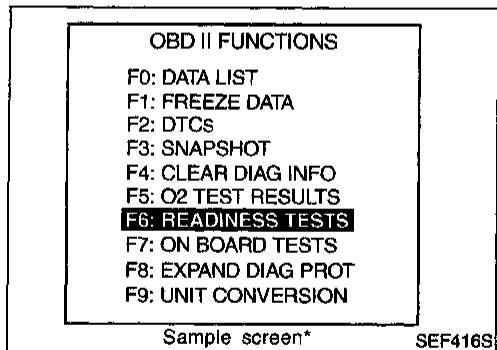

# ON BOARD DIAGNOSTIC SYSTEM DESCRIPTION

Generic Scan Tool (GST) (Cont'd)

FUNCTION		
Diagnostic test mode		Function
MODE 1	READINESS TESTS	This mode gains access to current emission-related data values, including analog inputs and outputs, digital inputs and outputs, and system status information.
MODE 2	(FREEZE DATA)	This mode gains access to emission-related data value which were stored by ECM during the freeze frame. [For details, refer to "Freeze Frame Data" (EC-70).]
MODE 3	DTCs	This mode gains access to emission-related power train trouble codes which were stored by ECM.
MODE 4	CLEAR DIAG INFO	This mode can clear all emission-related diagnostic information. This includes: <ul style="list-style-type: none"> <li>• Clear number of diagnostic trouble codes (MODE 1)</li> <li>• Clear diagnostic trouble codes (MODE 3)</li> <li>• Clear trouble code for freeze frame data (MODE 1)</li> <li>• Clear freeze frame data (MODE 2)</li> <li>• Reset status of system monitoring test (MODE 1)</li> <li>• Clear on board monitoring test results (MODE 6 and 7)</li> </ul>
MODE 6	(ON BOARD TESTS)	This mode accesses the results of on board diagnostic monitoring tests of specific components/systems that are not continuously monitored.
MODE 7	(ON BOARD TESTS)	This mode enables the off board test drive to obtain test results for emission-related powertrain components/systems that are continuously monitored during normal driving conditions.
MODE 8	—	This mode can close EVAP system in ignition switch "ON" position (Engine stopped). When this mode is performed, the following parts can be opened or closed. <ul style="list-style-type: none"> <li>• EVAP canister vent control valve open</li> <li>• Vacuum cut valve bypass valve closed</li> </ul> In the following conditions, this mode cannot function. <ul style="list-style-type: none"> <li>• Low ambient temperature</li> <li>• Low battery voltage</li> <li>• Engine running</li> <li>• Ignition switch "OFF"</li> <li>• Low fuel temperature</li> <li>• Too much pressure is applied to EVAP system</li> </ul>

NEEC0034503

GI  
 MA  
 EM  
 LC  
 EC  
 FE  
 CL  
 MT  
 AT  
 TF  
 PD  
 FA  
 RA  
 BR  
 ST  
 RS  
 BT  
 HA  
 EL  
 IDX

# TROUBLE DIAGNOSIS — INTRODUCTION

## Introduction

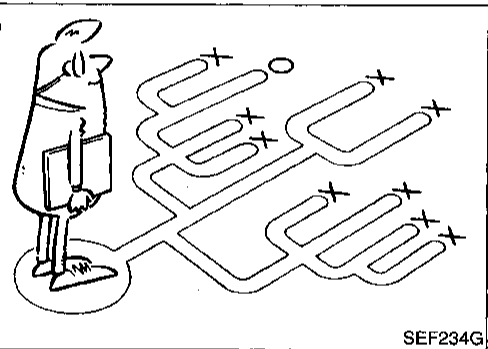
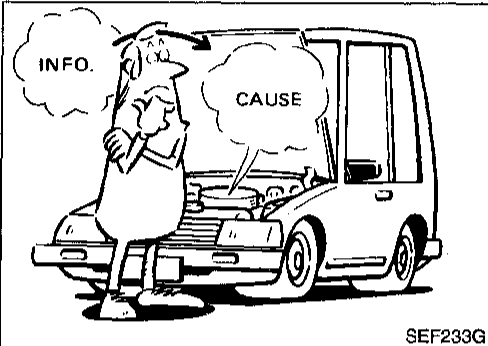
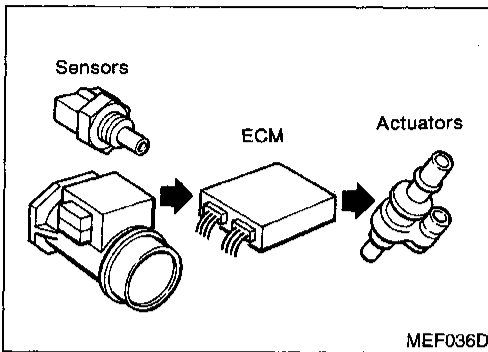

### KEY POINTS

- WHAT** ..... Vehicle & engine model
- WHEN** ..... Date, Frequencies
- WHERE** ..... Road conditions
- HOW** ..... Operating conditions,  
Weather conditions,  
Symptoms

SEF907L

## Introduction

NEEC0035

The engine has an ECM to control major systems such as fuel control, ignition control, idle air control system, etc. The ECM accepts input signals from sensors and instantly drives actuators. It is essential that both input and output signals are proper and stable. At the same time, it is important that there are no problems such as vacuum leaks, fouled spark plugs, or other problems with the engine.

It is much more difficult to diagnose a problem that occurs intermittently rather than continuously. Most intermittent problems are caused by poor electric connections or improper wiring. In this case, careful checking of suspected circuits may help prevent the replacement of good parts.

A visual check only may not find the cause of the problems. A road test with CONSULT (or GST) or a circuit tester connected should be performed. Follow the "Work Flow" on EC-84.

Before undertaking actual checks, take a few minutes to talk with a customer who approaches with a driveability complaint. The customer can supply good information about such problems, especially intermittent ones. Find out what symptoms are present and under what conditions they occur. A "Diagnostic Worksheet" like the example on next page should be used.

Start your diagnosis by looking for "conventional" problems first. This will help troubleshoot driveability problems on an electronically controlled engine vehicle.

## DIAGNOSTIC WORKSHEET

NEEC0035501

There are many operating conditions that lead to the malfunction of engine components. A good grasp of such conditions can make trouble-shooting faster and more accurate.

In general, each customer feels differently about a problem. It is important to fully understand the symptoms or conditions for a customer complaint.

Utilize a diagnostic worksheet like the one on the next page in order to organize all the information for troubleshooting.

Some conditions may cause the MIL to come on steady or blink and DTC to be detected. Examples:

- Vehicle ran out of fuel, which caused the engine to misfire.
- Fuel filler cap was left off or incorrectly screwed on, allowing fuel to evaporate into the atmosphere [for the models with EVAP (SMALL LEAK) diagnosis].





# TROUBLE DIAGNOSIS — INTRODUCTION

Work Flow

## Work Flow

NEEC0036

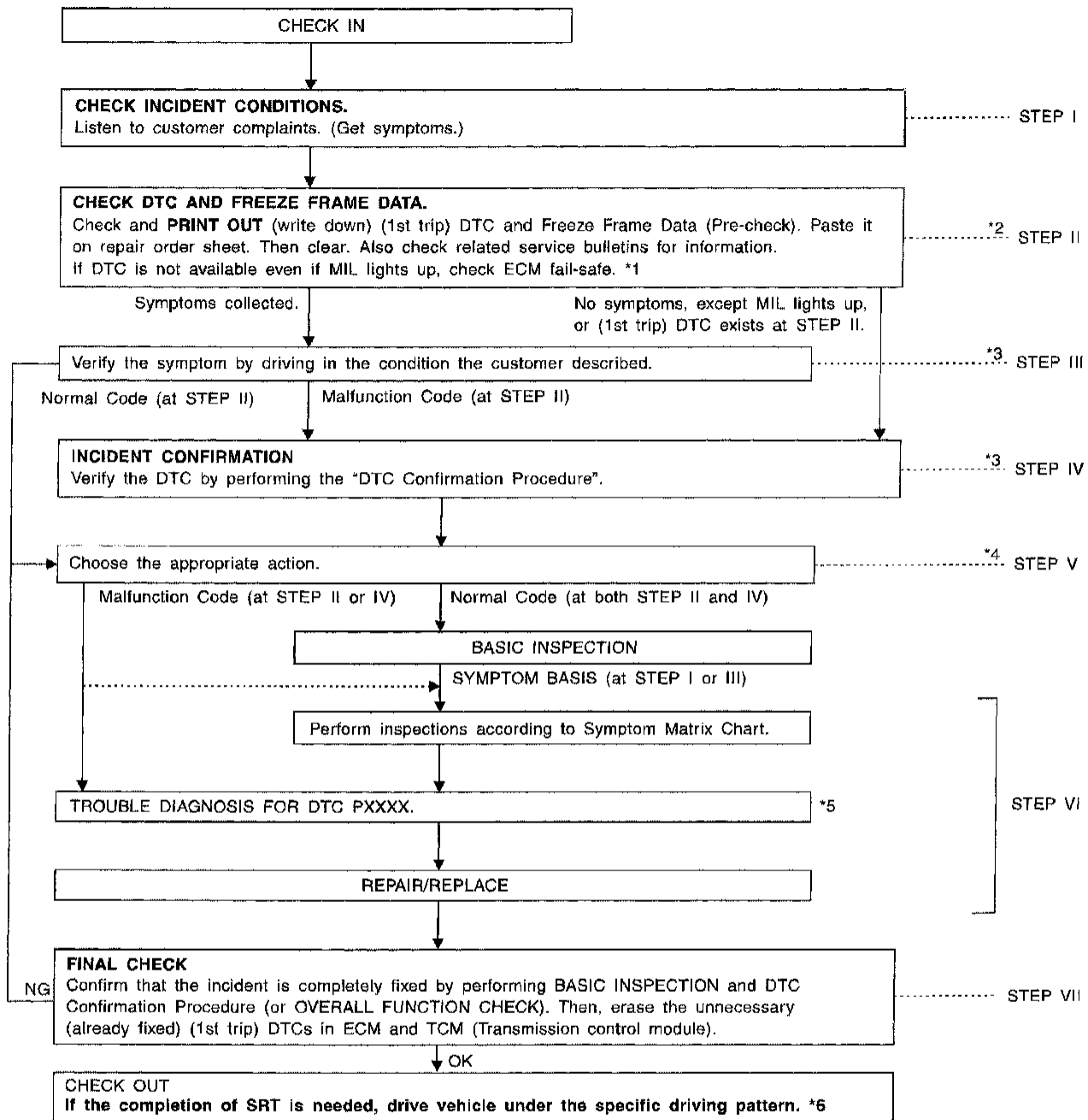

SEF935V

\*1 EC-96

\*2 If time data of "SELF-DIAG RESULTS" is other than "0" or "[1]", perform "TROUBLE DIAGNOSIS FOR INTERMITTENT INCIDENT", EC-115.

\*3 If the incident cannot be verified,

perform "TROUBLE DIAGNOSIS FOR INTERMITTENT INCIDENT", EC-115.

\*4 If the on board diagnostic system cannot be performed, check main power supply and ground circuit. Refer to "TROUBLE DIAGNOSIS FOR POWER SUPPLY", EC-116.

\*5 If malfunctioning part cannot be detected, perform "TROUBLE DIAGNOSIS FOR INTERMITTENT INCIDENT", EC-115.

\*6 EC-49

# TROUBLE DIAGNOSIS — INTRODUCTION

Work Flow (Cont'd)

<b>DESCRIPTION FOR WORK FLOW</b>	
STEP	DESCRIPTION
STEP I	Get detailed information about the conditions and the environment when the incident/symptom occurred using the "DIAGNOSTIC WORK SHEET", EC-83.
STEP II	Before confirming the concern, check and write down (print out using CONSULT or GST) the (1st trip) DTC and the (1st trip) freeze frame data, then erase the DTC and the data. (Refer to EC-55.) The (1st trip) DTC and the (1st trip) freeze frame data can be used when duplicating the incident at STEP III & IV. If the incident cannot be verified, perform "TROUBLE DIAGNOSIS FOR INTERMITTENT INCIDENT", EC-115. Study the relationship between the cause, specified by (1st trip) DTC, and the symptom described by the customer. (The "Symptom Matrix Chart" will be useful. See EC-97.) Also check related service bulletins for information.
STEP III	Try to confirm the symptom and under what conditions the incident occurs. The "DIAGNOSTIC WORK SHEET" and the freeze frame data are useful to verify the incident. Connect CONSULT to the vehicle in DATA MONITOR (AUTO TRIG) mode and check real time diagnosis results. If the incident cannot be verified, perform "TROUBLE DIAGNOSIS FOR INTERMITTENT INCIDENT", EC-115. If the malfunction code is detected, skip STEP IV and perform STEP V.
STEP IV	Try to detect the (1st trip) DTC by driving in (or performing) the "DTC Confirmation Procedure". Check and read the (1st trip) DTC and (1st trip) freeze frame data by using CONSULT or GST. During the (1st trip) DTC verification, be sure to connect CONSULT to the vehicle in DATA MONITOR (AUTO TRIG) mode and check real time diagnosis results. If the incident cannot be verified, perform "TROUBLE DIAGNOSIS FOR INTERMITTENT INCIDENT", EC-115. In case the "DTC Confirmation Procedure" is not available, perform the "Overall Function Check" instead. The (1st trip) DTC cannot be displayed by this check, however, this simplified "check" is an effective alternative. The "NG" result of the "Overall Function Check" is the same as the (1st trip) DTC detection.
STEP V	Take the appropriate action based on the results of STEP I through IV. If the malfunction code is indicated, proceed to TROUBLE DIAGNOSIS FOR DTC PXXXX. If the normal code is indicated, proceed to the BASIC INSPECTION. (Refer to EC-86.) Then perform inspections according to the Symptom Matrix Chart. (Refer to EC-97.)
STEP VI	Identify where to begin diagnosis based on the relationship study between symptom and possible causes. Inspect the system for mechanical binding, loose connectors or wiring damage using (tracing) "Harness Layouts". Gently shake the related connectors, components or wiring harness with CONSULT set in "DATA MONITOR (AUTO TRIG)" mode. Check the voltage of the related ECM terminals or monitor the output data from the related sensors with CONSULT. Refer to EC-101, EC-106. The "Diagnostic Procedure" in EC section contains a description based on open circuit inspection. A short circuit inspection is also required for the circuit check in the Diagnostic Procedure. For details, refer to GI section ("HOW TO PERFORM EFFICIENT DIAGNOSIS FOR AN ELECTRICAL INCIDENT", "Circuit Inspection"). Repair or replace the malfunction parts. If malfunctioning part cannot be detected, perform "TROUBLE DIAGNOSIS FOR INTERMITTENT INCIDENT", EC-115.
STEP VII	Once you have repaired the circuit or replaced a component, you need to run the engine in the same conditions and circumstances which resulted in the customer's initial complaint. Perform the "DTC Confirmation Procedure" and confirm the normal code [DTC No. P0000 or 0505] is detected. If the incident is still detected in the final check, perform STEP VI by using a different method from the previous one. Before returning the vehicle to the customer, be sure to erase the unnecessary (already fixed) (1st trip) DTC in ECM and TCM (Transmission control module). (Refer to EC-55.)

NEEC0036S01

GI  
MA  
EM  
LC  
EC  
FE  
CL  
MT  
AT  
TF  
PD  
FA  
RA  
BR  
ST  
RS  
BT  
HA  
EL  
IDX

# TROUBLE DIAGNOSIS — BASIC INSPECTION

Basic Inspection

## Basic Inspection



NEEC0037

### Precaution:

Perform Basic Inspection without electrical or mechanical loads applied;

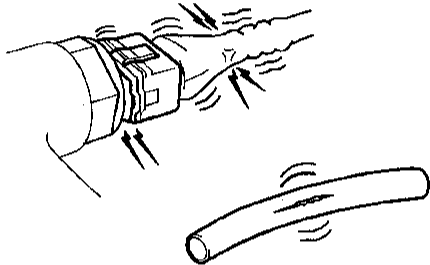
- Headlamp switch is OFF,
- Air conditioner switch is OFF,
- Rear window defogger switch is OFF,
- Steering wheel is in the straight-ahead position, etc.

<b>1</b>	<b>INSPECTION START</b>
<p>1. Check service records for any recent repairs that may indicate a related problem, or the current need for scheduled maintenance.</p> <p>2. Open engine hood and check the following:</p> <ul style="list-style-type: none"> <li>• Harness connectors for improper connections</li> <li>• Vacuum hoses for splits, kinks, or improper connections</li> <li>• Wiring for improper connections, pinches, or cuts</li> </ul>	
	
SEF983U	
Models with CONSULT	▶ GO TO 2.
Models with GST	▶ GO TO 2.
Models with No Tools	▶ GO TO 16.

<b>2</b>	<b>CONNECT CONSULT OR GST TO THE VEHICLE</b>
<p> <b>With CONSULT</b> Connect "CONSULT" to the data link connector for CONSULT and select "ENGINE" from the menu. Refer to EC-66.</p>	
<p> <b>With GST</b> Connect "GST" to the data link connector for GST. Refer to EC-80.</p>	
Models with CONSULT	▶ GO TO 3.
Models with GST	▶ GO TO 15.

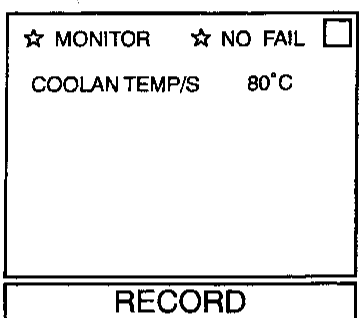
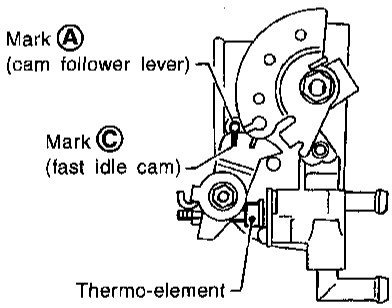
<b>3</b>	<b>CHECK FI CAM FUNCTION</b>
<p> <b>With CONSULT</b></p> <ol style="list-style-type: none"> <li>1. Turn ignition switch "ON".</li> <li>2. Select "COOLAN TEMP/S" in "DATA MONITOR" mode with CONSULT.</li> <li>3. Start engine and warm it up.</li> </ol>	
	
SEF522P	
<p>4. When engine coolant temperature is 75 to 85°C (167 to 185°F), check the following.</p> <ul style="list-style-type: none"> <li>• The center of mark <b>A</b> is aligned with mark <b>C</b>.</li> <li>• The cam follower lever's roller is not touching the fast idle cam.</li> </ul>	
	
SEF971R	
<b>OK or NG</b>	
OK	▶ GO TO 4.
NG	▶ Check FI cam. Refer to "Fast Idle Cam (FIC)", EC-33.

# TROUBLE DIAGNOSIS — BASIC INSPECTION

Basic Inspection (Cont'd)

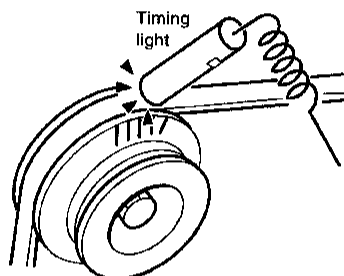
<b>4</b>	<b>CHECK IGNITION TIMING</b>
<p><b>With CONSULT</b></p> <ol style="list-style-type: none"> <li>Warm up engine to normal operating temperature.</li> <li>Select "IACV-AAC/V ADJ" in "WORK SUPPORT" mode and touch "START".</li> </ol>	
<div style="border: 1px solid black; padding: 5px; width: fit-content; margin: 0 auto;"> <p style="text-align: center;">■ IACV-AAC/V ADJ ■ □</p> <p style="text-align: center;">*** ADJ MONITOR ***</p> <p>CMPS•RPM(POS)      700rpm</p> <p>— CONDITION SETTING —</p> <p>IACV-ACC/V            FIXED</p> <hr/> <p>===== MONITOR =====</p> <p>COOLAN TEMP/S      90°C</p> <p>CLSD THL POS        0 N</p> <p style="text-align: center; border-top: 1px solid black; padding-top: 5px;"><b>CANCEL</b></p> </div>	
SEF120W	
<p>3. Check ignition timing at idle using a timing light.</p>	
	
<p>Ignition timing: <math>15^{\circ} \pm 2^{\circ}</math> BTDC</p>	
SEF984U	
<b>OK or NG</b>	
OK	▶ GO TO 5.
NG	▶ <ol style="list-style-type: none"> <li>Adjust ignition timing by turning distributor. Refer to "Idle Speed/Ignition Timing/Idle Mixture Ratio Adjustment", EC-35.</li> <li>GO TO 5.</li> </ol>

<b>5</b>	<b>CHECK BASE IDLE SPEED</b>
<p><b>With CONSULT</b></p> <ol style="list-style-type: none"> <li>Select "IACV-AAC/V ADJ" in "WORK SUPPORT" mode and touch "START".</li> </ol>	
<div style="border: 1px solid black; padding: 5px; width: fit-content; margin: 0 auto;"> <p style="text-align: center;">■ IACV-AAC/V ADJ ■ □</p> <p style="text-align: center;">*** ADJ MONITOR ***</p> <p>CMPS•RPM(POS)      700rpm</p> <p>— CONDITION SETTING —</p> <p>IACV-ACC/V            FIXED</p> <hr/> <p>===== MONITOR =====</p> <p>COOLAN TEMP/S      90°C</p> <p>CLSD THL POS        0 N</p> <p style="text-align: center; border-top: 1px solid black; padding-top: 5px;"><b>CANCEL</b></p> </div>	
SEF120W	
<p>2. Check idle speed.</p> <p style="text-align: center;"><b><math>700 \pm 50</math> rpm (in "P" or "N" position)</b></p> <p style="text-align: center;"><b>OK or NG</b></p>	
OK	▶ GO TO 6.
NG	▶ <ol style="list-style-type: none"> <li>Adjust engine speed by turning idle speed adjusting screw. Refer to "Idle Speed/Ignition Timing/Idle Mixture Ratio Adjustment", EC-35.</li> <li>GO TO 6.</li> </ol>

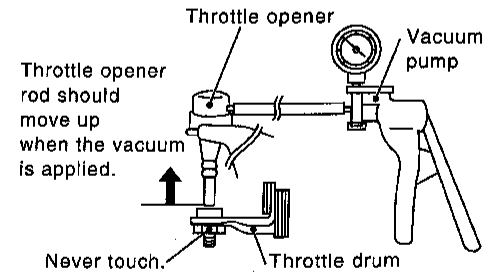
<b>6</b>	<b>CHECK CLOSED THROTTLE POSITION SWITCH IDLE POSITION-I</b>
<p><b>With CONSULT</b></p> <p><b>NOTE:</b></p> <p><b>Always check ignition timing and base idle speed before performing the following.</b></p> <ol style="list-style-type: none"> <li>Warm up engine to normal operating temperature.</li> <li>Check FI cam, refer to procedure 3.</li> <li>Stop engine.</li> <li>Remove the vacuum hose connected to the throttle opener.</li> <li>Connect suitable vacuum hose to vacuum pump as shown below.</li> </ol>	
	
SEF793W	
<p>6. Apply vacuum [more than -40.0 kPa (-300 mmHg, -11.81 inHg)]</p>	
▶ GO TO 7.	

GI  
 MA  
 EM  
 LC  
**EC**  
 FE  
 CL  
 MT  
 AT  
 TF  
 PD  
 FA  
 RA  
 BR  
 ST  
 RS  
 BT  
 HA  
 EL  
 IDX

# TROUBLE DIAGNOSIS — BASIC INSPECTION

Basic Inspection (Cont'd)

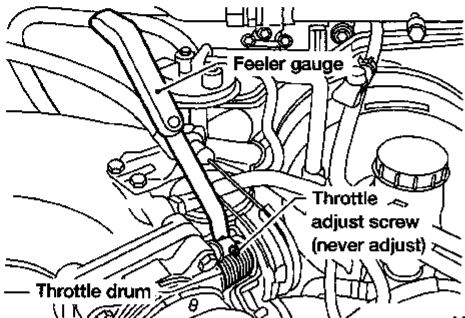
<b>7</b>	<b>CHECK CLOSED THROTTLE POSITION SWITCH IDLE POSITION-II</b>						
<ol style="list-style-type: none"> <li>1. Turn ignition switch "ON".</li> <li>2. Select "CLSD THL/P SW" in "DATA MONITOR" mode.</li> <li>3. Read "CLSD THL/P SW" signal under the following conditions. <ul style="list-style-type: none"> <li>• Insert a 0.3 mm (0.012 in) and 0.4 mm (0.016 in) feeler gauge alternately between the throttle adjust screw (TAS) and throttle drum as shown in the figure and check the signal.</li> </ul> </li> </ol>							
 <p style="text-align: right; margin-right: 50px;">AEC887A</p>							
<table border="1" style="width: 100%; border-collapse: collapse;"> <tr> <td style="width: 50%; text-align: center;">                 ☆ MONITOR CLSD THL/P SW             </td> <td style="width: 50%; text-align: center;">                 ☆ NO FAIL ON             </td> </tr> <tr> <td colspan="2" style="text-align: center; padding: 5px;"><b>RECORD</b></td> </tr> </table> <p style="text-align: right; margin-right: 50px;">SEF577W</p>		☆ MONITOR CLSD THL/P SW	☆ NO FAIL ON	<b>RECORD</b>			
☆ MONITOR CLSD THL/P SW	☆ NO FAIL ON						
<b>RECORD</b>							
<p>"CLSD THL/P SW" signal should remain "ON" while inserting 0.3 mm (0.012 in) feeler gauge.                  "CLSD THL/P SW" signal should remain "OFF" while inserting 0.4 mm (0.016 in) feeler gauge.</p> <p style="text-align: center;">OK or NG</p> <table border="1" style="width: 100%; border-collapse: collapse;"> <tr> <td style="width: 15%; text-align: center;">OK</td> <td style="width: 10%; text-align: center;">▶</td> <td style="width: 75%;">GO TO 12.</td> </tr> <tr> <td style="text-align: center;">NG</td> <td style="text-align: center;">▶</td> <td style="text-align: center;">GO TO 8.</td> </tr> </table>		OK	▶	GO TO 12.	NG	▶	GO TO 8.
OK	▶	GO TO 12.					
NG	▶	GO TO 8.					

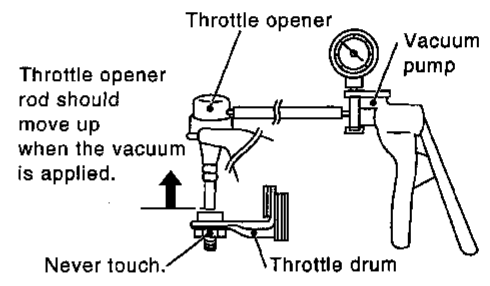
<b>8</b>	<b>ADJUSTMENT THROTTLE POSITION SWITCH IDLE POSITION</b>
<p>Ⓟ With CONSULT</p> <p><b>NOTE:</b></p> <ul style="list-style-type: none"> <li>• Never adjust throttle adjust screw (TAS).</li> <li>• Do not touch throttle drum when checking "CLSD THL/P SW" signal, doing so may cause an incorrect adjustment.</li> </ul> <ol style="list-style-type: none"> <li>1. Warm up engine to normal operating temperature.</li> <li>2. Check FI cam. Refer to procedure 3.</li> <li>3. Stop engine.</li> <li>4. Loosen throttle position sensor fixing bolts.</li> <li>5. Remove the vacuum hose connected to the throttle opener.</li> <li>6. Connect suitable vacuum hose to vacuum pump as shown below.</li> </ol>	
 <p style="text-align: right; margin-right: 50px;">SEF793W</p>	
<ol style="list-style-type: none"> <li>7. Apply vacuum [more than -40.0 kPa (-300 mmHg, -11.82 inHg)] until the throttle drum becomes free from the rod of the throttle opener. During adjustment procedure, vacuum should be applied.</li> </ol>	
▶ GO TO 9.	

# TROUBLE DIAGNOSIS — BASIC INSPECTION

Basic Inspection (Cont'd)

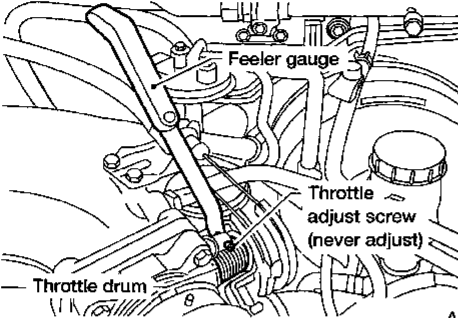
<b>9</b>	<b>ADJUSTMENT CLOSED THROTTLE POSITION SWITCH IDLE POSITION-II</b>						
<ol style="list-style-type: none"> <li>1. Turn ignition switch "ON".</li> <li>2. Select "CLSD THL/P SW" in "DATA MONITOR" mode.</li> <li>3. Insert 0.35 mm (0.0138 in) feeler gauge between throttle adjust screw and throttle drum as shown in the figure.</li> </ol>							
							
<ol style="list-style-type: none"> <li>4. Open throttle valve and then close.</li> <li>5. Check "CLSD THL/P SW" signal.</li> </ol>							
<table border="1" style="width: 100%; border-collapse: collapse;"> <tr> <td style="width: 50%; text-align: center;">                 ☆ MONITOR    ☆ NO FAIL                  CLSD THL/P SW    OFF             </td> <td style="width: 5%; text-align: center;"> <input type="checkbox"/> </td> </tr> <tr> <td colspan="2" style="text-align: center; padding: 5px;"><b>RECORD</b></td> </tr> </table>		☆ MONITOR    ☆ NO FAIL CLSD THL/P SW    OFF	<input type="checkbox"/>	<b>RECORD</b>			
☆ MONITOR    ☆ NO FAIL CLSD THL/P SW    OFF	<input type="checkbox"/>						
<b>RECORD</b>							
SEF122W							
<p>"CLSD THL/P SW" signal should remain "OFF" when the throttle valve is closed.</p> <p style="text-align: center;"><b>OK or NG</b></p> <table style="width: 100%; border-collapse: collapse;"> <tr> <td style="width: 15%; border: none;">OK</td> <td style="width: 5%; border: none; text-align: center;">▶</td> <td style="border: none;">GO TO 9.</td> </tr> <tr> <td style="border: none;">NG</td> <td style="border: none; text-align: center;">▶</td> <td style="border: none;">GO TO 8.</td> </tr> </table>		OK	▶	GO TO 9.	NG	▶	GO TO 8.
OK	▶	GO TO 9.					
NG	▶	GO TO 8.					

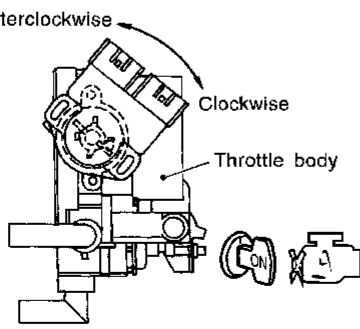
<b>10</b>	<b>ADJUSTMENT THROTTLE POSITION SWITCH IDLE POSITION-III</b>
<p><b>With CONSULT</b>                  Turn throttle position sensor body clockwise until "CLSD THL/P SW" signal switches to "OFF".</p>	
	
SEF689W	
▶ GO TO 11.	

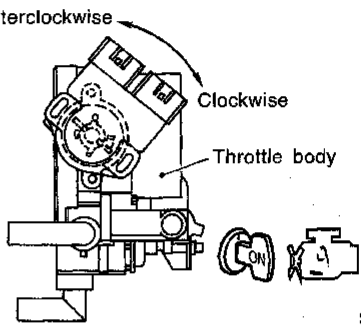
<b>11</b>	<b>ADJUSTMENT THROTTLE POSITION SWITCH IDLE POSITION-IV</b>						
<p><b>With CONSULT</b></p> <ol style="list-style-type: none"> <li>1. Remove 0.35 mm (0.0138 in) feeler gauge then insert 0.3 mm (0.012 in) feeler gauge.</li> <li>2. Temporarily tighten sensor body fixing bolts as follows.                     <ul style="list-style-type: none"> <li>• Gradually move the sensor body counterclockwise and stop it when "CLSD THL/P SW" signal switches from "OFF" to "ON", then temporarily tighten sensor body fixing bolts.</li> </ul> </li> </ol>							
							
SEF689W							
<ol style="list-style-type: none"> <li>3. Make sure two or three times that the signal is "ON" when the throttle valve is closed and "OFF" when it is opened.</li> <li>4. Remove 0.3 mm (0.012 in) feeler gauge then insert 0.4 mm (0.016 in) feeler gauge.</li> <li>5. Make sure two or three times that the signal remains "OFF" when the throttle valve is closed.</li> <li>6. Tighten throttle position sensor.</li> <li>7. Check the "CLSD THL/P SW" signal again.                      The signal remains "OFF" while closing throttle valve.</li> </ol> <p style="text-align: center;"><b>OK or NG</b></p> <table style="width: 100%; border-collapse: collapse;"> <tr> <td style="width: 15%; border: none;">OK</td> <td style="width: 5%; border: none; text-align: center;">▶</td> <td style="border: none;">GO TO 12.</td> </tr> <tr> <td style="border: none;">NG</td> <td style="border: none; text-align: center;">▶</td> <td style="border: none;">GO TO 8.</td> </tr> </table>		OK	▶	GO TO 12.	NG	▶	GO TO 8.
OK	▶	GO TO 12.					
NG	▶	GO TO 8.					

<b>12</b>	<b>REMOVE VACUUM PUMP</b>
<ol style="list-style-type: none"> <li>1. Remove feeler gauge.</li> <li>2. Release vacuum from the throttle opener.</li> <li>3. Remove vacuum pump and vacuum hose from the throttle opener.</li> <li>4. Reinstall the original vacuum hose to the throttle opener securely.</li> </ol>	
▶ GO TO 13.	

GI  
 MA  
 EM  
 LC  
**EC**  
 FE  
 CL  
 MT  
 AT  
 TF  
 PD  
 FA  
 RA  
 BR  
 ST  
 RS  
 BT  
 HA  
 EL  
 IDX

# TROUBLE DIAGNOSIS — BASIC INSPECTION

Basic Inspection (Cont'd)

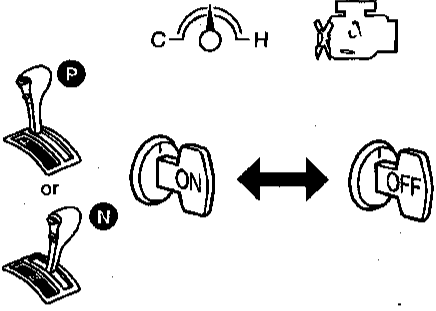
<b>13</b>	<b>RESET THROTTLE POSITION SENSOR IDLE POSITION MEMORY</b>									
<p><b>With CONSULT</b></p> <p><b>NOTE:</b> Always warm up engine to normal operating temperature. If engine is cool, the throttle position sensor idle position memory will not be reset correctly.</p> <ol style="list-style-type: none"> <li>1. Start engine.</li> <li>2. Warm up engine to normal operating temperature.</li> <li>3. Select "CLSD THL POS" in "DATA MONITOR" mode.</li> <li>4. Stop engine. (Turn ignition switch "OFF".)</li> <li>5. Turn ignition switch "ON" and wait at least 5 seconds.</li> </ol>										
										
SEF864V										
<ol style="list-style-type: none"> <li>6. Turn ignition switch "OFF" and wait at least 5 seconds.</li> <li>7. Repeat steps 5 and 6 until "CLSD THL POS" signal changes to "ON".</li> </ol>										
<table border="1" style="width: 100%; border-collapse: collapse;"> <tr> <td style="width: 50%; text-align: center;">☆ MONITOR</td> <td style="width: 50%; text-align: center;">☆ NO FAIL</td> <td style="width: 5%; text-align: center;"><input type="checkbox"/></td> </tr> <tr> <td style="text-align: center;">CLSD THL POS</td> <td style="text-align: center;">ON</td> <td></td> </tr> <tr> <td colspan="3" style="text-align: center;"><b>RECORD</b></td> </tr> </table>		☆ MONITOR	☆ NO FAIL	<input type="checkbox"/>	CLSD THL POS	ON		<b>RECORD</b>		
☆ MONITOR	☆ NO FAIL	<input type="checkbox"/>								
CLSD THL POS	ON									
<b>RECORD</b>										
SEF123W										
▶ GO TO 14.										

<b>14</b>	<b>CHECK TARGET IDLE SPEED</b>
<p><b>With CONSULT</b></p> <ol style="list-style-type: none"> <li>1. Start engine and warm it up to normal operating temperature.</li> <li>2. Select "CMPS-RPM (REF)" in "DATA MONITOR" mode.</li> <li>3. Check idle speed. <b>750±50 rpm (In "P" or "N" position)</b></li> </ol>	
<b>OK or NG</b>	
OK ▶	<b>INSPECTION END</b>
NG ▶	Adjust idle speed. Refer to "Idle Speed/Ignition Timing/Idle Mixture Ratio Adjustment", EC-35.

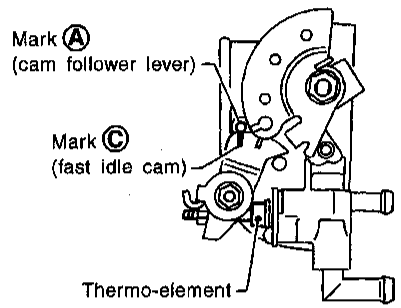
<b>15</b>	<b>CHECK FI CAM FUNCTION</b>
<p><b>With GST</b></p> <ol style="list-style-type: none"> <li>1. Turn ignition switch "ON".</li> <li>2. Select "MODE 1" with GST.</li> <li>3. Start engine and warm it up.</li> <li>4. When engine coolant temperature is 75 to 85°C (167 to 185°F), check the following. <ul style="list-style-type: none"> <li>• The center of mark A is aligned with mark C.</li> <li>• The cam follower lever's roller is not touching the fast idle cam.</li> </ul> </li> </ol>	
	
SEF971R	
<b>OK or NG</b>	
OK ▶	GO TO 17.
NG ▶	Check FI cam. Refer to "Fast Idle Cam (FIC)", EC-33.



# TROUBLE DIAGNOSIS — BASIC INSPECTION

Basic Inspection (Cont'd)

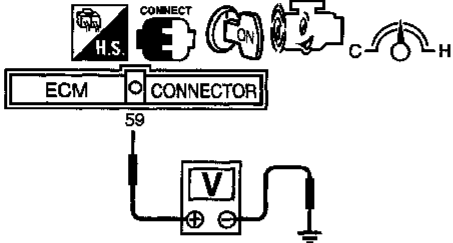
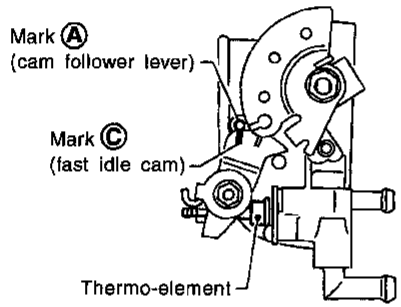
<b>16</b>	<b>CHECK FI CAM FUNCTION</b>
<p><b>No Tools</b></p> <ol style="list-style-type: none"> <li>Set the voltmeter between ECM terminal 59 (Engine coolant temperature sensor signal) and ground.</li> <li>Start engine and warm it up.</li> </ol>	
	
SEF119W	
<ol style="list-style-type: none"> <li>When the voltage is between 1.10 to 1.36V, check the following.                     <ul style="list-style-type: none"> <li>The center of mark <b>A</b> is aligned with mark <b>C</b>.</li> <li>The cam follower lever's roller is not touching the fast idle cam.</li> </ul> </li> </ol>	
	
SEF971R	
<b>OK or NG</b>	
OK	▶ GO TO 17.
NG	▶ Check FI cam. Refer to "Fast Idle Cam (FIC)", EC-33.

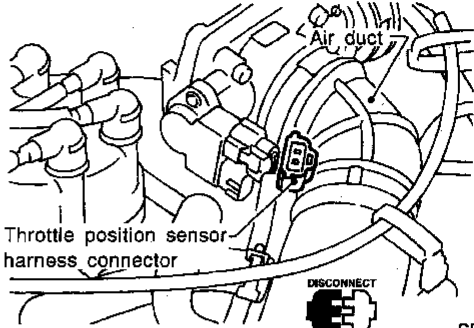
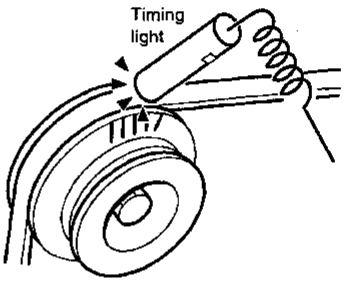
<b>17</b>	<b>CHECK IGNITION TIMING</b>
<p><b>Without CONSULT</b></p> <ol style="list-style-type: none"> <li>Warm up engine to normal operating temperature.</li> <li>Stop engine and disconnect throttle position sensor harness connector.</li> </ol>	
	
SEF975R	
<ol style="list-style-type: none"> <li>Start engine.</li> <li>Check ignition timing at idle using a timing light.</li> </ol>	
	
<b>Ignition timing: 15° ± 2° BTDC</b> <b>OK or NG</b>	
OK	▶ GO TO 18.
NG	▶ <ol style="list-style-type: none"> <li>Adjust ignition timing by turning distributor. Refer to "Idle Speed/Ignition Timing/ Idle Mixture Ratio Adjustment", EC-35.</li> <li>GO TO 18.</li> </ol>

<b>18</b>	<b>CHECK BASE IDLE SPEED</b>
<p><b>Without CONSULT</b></p> <p>Does engine speed fall to the following speed?  <b>700 ± 50 rpm (in "P" or "N" position)</b></p>	
<b>OK or NG</b>	
OK	▶ GO TO 19.
NG	▶ <ol style="list-style-type: none"> <li>Adjust engine speed by turning idle speed adjusting screw. Refer to "Idle Speed/Ignition Timing/ Idle Mixture Ratio Adjustment", EC-35.</li> <li>GO TO 19.</li> </ol>

GI  
 MA  
 EM  
 LC  
 EC  
 FE  
 CL  
 MT  
 AT  
 TF  
 PD  
 FA  
 RA  
 BR  
 ST  
 RS  
 BT  
 HA  
 EL  
 IDX

# TROUBLE DIAGNOSIS — BASIC INSPECTION

Basic Inspection (Cont'd)

<b>19</b>	<b>CHECK CLOSED THROTTLE POSITION SWITCH IDLE POSITION</b>
<p> <b>Without CONSULT</b>  <b>NOTE:</b>  <b>Always check ignition timing and base idle speed before performing the following.</b></p> <ol style="list-style-type: none"> <li>1. Warm up engine to normal operating temperature.</li> <li>2. Check FI cam, refer to procedure 12 or 13.</li> <li>3. Stop engine.</li> <li>4. Remove the vacuum hose connected to the throttle opener.</li> <li>5. Connect suitable vacuum hose to vacuum pump as shown below.</li> </ol>	
SEF793W	
<ol style="list-style-type: none"> <li>6. Apply vacuum [more than -40.0 kPa (-300 mmHg, -11.81 inHg)] until the throttle drum becomes free from the rod of the throttle opener. During checking procedure, vacuum should be applied.</li> </ol>	
▶ GO TO 20.	

<b>20</b>	<b>CHECK CLOSED THROTTLE POSITION SWITCH IDLE POSITION-I</b>
<ol style="list-style-type: none"> <li>1. Disconnect closed throttle position switch harness connector.</li> <li>2. Check continuity between closed throttle position switch terminals 5 and 6 under the following conditions.</li> </ol>	
SEF862V	
<ul style="list-style-type: none"> <li>• Insert the 0.3 mm (0.012 in) and 0.4 mm (0.016 in) feeler gauge alternately between the throttle adjust screw (TAS) and throttle drum as shown in the figure.</li> </ul>	
AEC887A	
<p><b>"Continuity should exist" while inserting 0.3 mm (0.012 in) feeler gauge.</b>  <b>"Continuity should not exist" while inserting 0.4 mm (0.016 in) feeler gauge.</b></p>	
<b>OK or NG</b>	
OK	▶ GO TO 25.
NG	▶ GO TO 21.

# TROUBLE DIAGNOSIS — BASIC INSPECTION

Basic Inspection (Cont'd)

## 21 ADJUSTMENT THROTTLE POSITION SWITCH IDLE POSITION

**⊗ Without CONSULT**

**NOTE:**

- Never adjust throttle adjust screw (TAS).
- Do not touch throttle drum when checking "continuity", doing so may cause an incorrect adjustment.

1. Warm up engine to normal operating temperature.
2. Check FI cam. Refer to procedure 12 or 13.
3. Stop engine.
4. Loosen throttle position sensor fixing bolts.
5. Remove the vacuum hose connected to the throttle opener.
6. Connect suitable vacuum hose to vacuum pump as shown below.

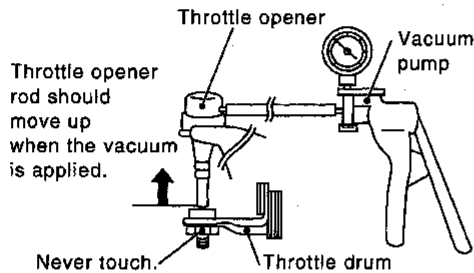

SEF793W

7. Apply vacuum [more than -40.0 kPa (-300 mmHg, -11.81 inHg)] until the throttle drum becomes free from the rod of the throttle opener. During adjustment procedure, vacuum should be applied.

▶ GO TO 22.

## 22 ADJUSTMENT CLOSED THROTTLE POSITION SWITCH IDLE POSITION-II

1. Disconnect closed throttle position switch harness connector.
2. Insert 0.35 mm (0.0138 in) feeler gauge between the throttle adjust screw and throttle drum as shown in the figure.

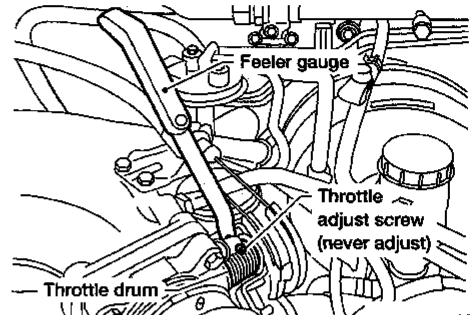

3. Open throttle valve then close.
4. Check continuity between closed throttle position switch terminals 5 and 6.

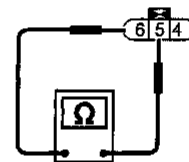
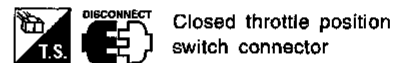

SEF862V

Continuity should not exist while closing the throttle position sensor.

OK or NG

OK ▶ GO TO 24.

NG ▶ GO TO 23.

## 23 ADJUSTMENT THROTTLE POSITION SWITCH IDLE POSITION-III

**⊗ Without CONSULT**

Turn throttle position sensor body clockwise until continuity does not exist.

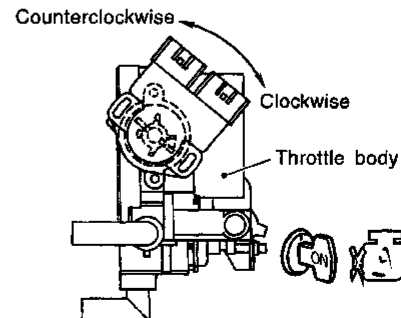

▶ GO TO 24.

GI  
MA  
EM  
LC  
EC  
FE  
CL  
MT  
AT  
TF  
PD  
FA  
RA  
BR  
ST  
RS  
BT  
HA  
EL  
IDX

# TROUBLE DIAGNOSIS — BASIC INSPECTION

Basic Inspection (Cont'd)

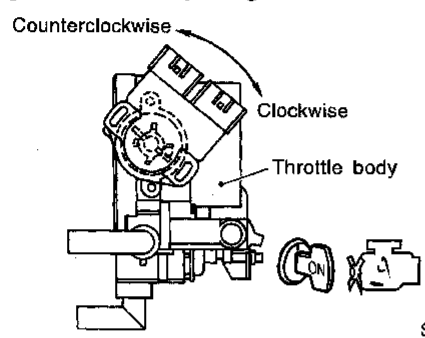
<b>24</b>	<b>ADJUSTMENT THROTTLE POSITION SWITCH IDLE POSITION-IV</b>						
<p><b>⊗ Without CONSULT</b></p> <ol style="list-style-type: none"> <li>Remove 0.35 mm (0.0138 in) feeler gauge then insert 0.3 mm (0.012 in) feeler gauge.</li> <li>Temporarily tighten sensor body fixing bolts as follows.           <ul style="list-style-type: none"> <li>Gradually move the sensor body counterclockwise and stop it when the continuity comes to exist, then temporarily tighten sensor body fixing bolts.</li> </ul> </li> </ol>  <ol style="list-style-type: none"> <li>Make sure two or three times that the continuity exists when the throttle valve is closed and continuity does not exist when it is opened.</li> <li>Remove 0.3 mm (0.012 in) feeler gauge then insert 0.4 mm (0.016 in) feeler gauge.</li> <li>Make sure two or three times that the continuity does not exist when the throttle valve is closed.</li> <li>Tighten throttle position sensor.</li> <li>Check the continuity again.           <p><b>Continuity does not exist while closing the throttle valve.</b></p> </li> </ol> <p style="text-align: center;"><b>OK or NG</b></p> <table border="1" style="width: 100%;"> <tr> <td style="width: 30%;">OK</td> <td style="width: 10%; text-align: center;">▶</td> <td>GO TO 25.</td> </tr> <tr> <td>NG</td> <td style="text-align: center;">▶</td> <td>GO TO 21.</td> </tr> </table>		OK	▶	GO TO 25.	NG	▶	GO TO 21.
OK	▶	GO TO 25.					
NG	▶	GO TO 21.					

<b>25</b>	<b>REINSTALLATION</b>
<p><b>⊗ Without CONSULT</b></p> <ol style="list-style-type: none"> <li>Remove feeler gauge.</li> <li>Release vacuum from the throttle opener.</li> <li>Remove vacuum pump and vacuum hose from the throttle opener.</li> <li>Reinstall the original vacuum hose to the throttle opener securely.</li> <li>Reconnect throttle position sensor harness connector and closed throttle position switch harness connector.</li> <li>Start engine and rev it (2,000 to 3,000 rpm) two or three times under no-load and then run engine at idle speed.</li> </ol> <p style="text-align: right;">▶ GO TO 26.</p>	

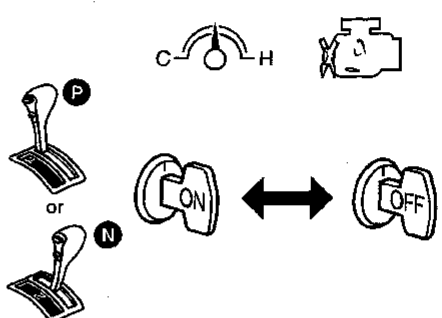
<b>26</b>	<b>RESET THROTTLE POSITION SENSOR IDLE POSITION MEMORY</b>
<p><b>⊗ Without CONSULT</b></p> <p><b>NOTE:</b> Always warm up engine to normal operating temperature. If engine is cool, the throttle position sensor idle position memory will not be reset correctly.</p> <ol style="list-style-type: none"> <li>Start engine.</li> <li>Warm up engine to normal operating temperature.</li> <li>Stop engine. (Turn ignition switch "OFF".)</li> <li>Turn ignition switch "ON" and wait at least 5 seconds.</li> </ol>  <ol style="list-style-type: none"> <li>Turn ignition switch "OFF" and wait at least 5 seconds.</li> <li>Repeat steps 4 and 5, 20 times.</li> </ol> <p style="text-align: right;">▶ GO TO 27.</p>	

<b>27</b>	<b>CHECK TARGET IDLE SPEED</b>						
<p><b>⊗ Without CONSULT</b></p> <ol style="list-style-type: none"> <li>Start engine and warm it up to normal operating temperature.</li> <li>Check idle speed.           <p style="text-align: center;"><b>750 ± 50 rpm (In "P" or "N" position)</b></p> </li> </ol> <p style="text-align: center;"><b>OK or NG</b></p> <table border="1" style="width: 100%;"> <tr> <td style="width: 30%;">OK</td> <td style="width: 10%; text-align: center;">▶</td> <td>GO TO 28.</td> </tr> <tr> <td>NG</td> <td style="text-align: center;">▶</td> <td>Adjust idle speed. Refer to "Idle Speed/Ignition Timing/Idle Mixture Ratio Adjustment", EC-35.</td> </tr> </table>		OK	▶	GO TO 28.	NG	▶	Adjust idle speed. Refer to "Idle Speed/Ignition Timing/Idle Mixture Ratio Adjustment", EC-35.
OK	▶	GO TO 28.					
NG	▶	Adjust idle speed. Refer to "Idle Speed/Ignition Timing/Idle Mixture Ratio Adjustment", EC-35.					

<b>28</b>	<b>ERASE UNNECESSARY DTC</b>
<p>After this inspection, unnecessary DTC No. might be displayed. Erase the stored memory in ECM and TCM (Transmission control module). Refer to "HOW TO ERASE EMISSION-RELATED DIAGNOSTIC INFORMATION", EC-55 and "HOW TO ERASE DTC" in AT section.</p> <p style="text-align: right;">▶ INSPECTION END</p>	

# TROUBLE DIAGNOSIS — GENERAL DESCRIPTION

*DTC Inspection Priority Chart*

## DTC Inspection Priority Chart

NEEC0028

If some DTCs are displayed at the same time, perform inspections one by one based on the following priority chart.

Priority	Detected items (DTC)
1	<ul style="list-style-type: none"> <li>• P0100 Mass air flow sensor (0102)</li> <li>• P0110 Intake air temperature sensor (0401)</li> <li>• P0115 P0125 Engine coolant temperature sensor (0103) (0908)</li> <li>• P0120 Throttle position sensor (0403)</li> <li>• P0180 Tank fuel temperature sensor (0402)</li> <li>• P0325 Knock sensor (0304)</li> <li>• P0335 P1336 Crankshaft position sensor (OBD) (0802) (0905)</li> <li>• P0340 Camshaft position sensor (0101)</li> <li>• P0500 Vehicle speed sensor (0104)</li> <li>• P0600 A/T communication line</li> <li>• P0605 ECM (0301)</li> <li>• P1320 Ignition signal (0201)</li> <li>• P1400 EGRC-solenoid valve (1005)</li> <li>• P1605 A/T diagnosis communication line (0804)</li> <li>• P1706 Park/Neutral position (PNP) switch (1003)</li> </ul>
2	<ul style="list-style-type: none"> <li>• P0105 Absolute pressure sensor (0803)</li> <li>• P0130-P0134, P0150-P0154 Front heated oxygen sensor (0413-0415) (0503)(0509), (0303) (0409-0412)</li> <li>• P0135 P0155 Front heated oxygen sensor heater (0901) (1001)</li> <li>• P0137-P0140, P0157-P0160 Rear heated oxygen sensor (0510-0512) (0707), (0313-0315) (0708)</li> <li>• P0141 P0161 Rear heated oxygen sensor heater (0902) (1002)</li> <li>• P0443 P1444 EVAP canister purge volume control solenoid valve (1008) (0214)</li> <li>• P0446 P1446 P1448 EVAP canister vent control valve (0903) (0215) (0309)</li> <li>• P0450 EVAP control system pressure sensor (0704)</li> <li>• P0510 Closed throttle position switch (0203)</li> <li>• P0705-P0755 P1705 P1760 A/T related sensors, solenoid valves and switches (1101-1208)</li> <li>• P1105 MAP/BARO switch solenoid valve (1302)</li> <li>• P1401 EGR temperature sensor (0305)</li> <li>• P1447 EVAP control system purge flow monitoring (0111)</li> <li>• P1490 P1491 Vacuum cut valve bypass valve (0801) (0311)</li> </ul>
3	<ul style="list-style-type: none"> <li>• P0171 P0172 P0174 P0175 Fuel injection system function (0115) (0114) (0210) (0209)</li> <li>• P0306 - P0300 Misfire (0603 - 0701)</li> <li>• P0400 P1402 EGR function (0302) (0514)</li> <li>• P0402 EGRC-BPT valve function (0306)</li> <li>• P0420 P0430 Three way catalyst function (0702) (0703)</li> <li>• P0440 P1440 EVAP control system (SMALL LEAK) (0705) (0213)</li> <li>• P0505 IACV-AAC valve (0205)</li> <li>• P0731-P0734 P0744 A/T function (1103 - 1106) (1107)</li> <li>• P1148 P1168 Closed loop control (0307) (0308)</li> </ul>

GI  
 MA  
 EM  
 LC  
**EC**  
 FE  
 CL  
 MT  
 AT  
 TF  
 PD  
 FA  
 RA  
 BR  
 ST  
 RS  
 BT  
 HA  
 EL  
 IDX

# TROUBLE DIAGNOSIS — GENERAL DESCRIPTION

Fail-safe Chart

## Fail-safe Chart

=NEEC0039

The ECM enters fail-safe mode, if any of the following malfunctions is detected due to the open or short circuit. When the ECM enters the fail-safe mode, the MIL illuminates.

DTC No.		Detected Items	Engine operating condition in fail-safe mode	
CONSULT GST	ECM*1			
P0100	0102	Mass air flow sensor circuit	Engine speed will not rise more than 2,400 rpm due to the fuel cut.	
P0115	0103	Engine coolant temperature sensor circuit	Engine coolant temperature will be determined by ECM based on the time after turning ignition switch "ON" or "START". CONSULT displays the engine coolant temperature decided by ECM.	
			Condition	Engine coolant temperature decided (CONSULT display)
			Just as ignition switch is turned ON or Start	40°C (104°F)
			More than approx. 4 minutes after ignition ON or Start	80°C (176°F)
			Except as shown above	40 - 80°C (104 - 176°F) (Depends on the time)
P0120	0403	Throttle position sensor circuit	Throttle position will be determined based on the injected fuel amount and the engine speed. Therefore, acceleration will be poor.	
			Condition	Driving condition
			When engine is idling	Normal
			When accelerating	Poor acceleration
Unable to access ECM	Unable to access Diagnostic Test Mode II	ECM	<p><b>ECM fail-safe activating condition</b> The computing function of the ECM was judged to be malfunctioning. When the fail-safe system activates (i.e., if the ECM detects a malfunction condition in the CPU of ECM), the MIL on the instrument panel lights to warn the driver. However it is not possible to access ECM and DTC cannot be confirmed.</p> <p><b>Engine control with fail-safe</b> When ECM fail-safe is operating, fuel injection, ignition timing, fuel pump operation, and IACV-AAC valve operation are controlled under certain limitations.</p>	
			ECM fail-safe operation	
			Engine speed	Engine speed will not rise more than 3,000 rpm
			Fuel injection	Simultaneous multiport fuel injection system
			Ignition timing	Ignition timing is fixed at the preset valve
			Fuel pump	Fuel pump relay is "ON" when engine is running and "OFF" when engine stalls
			IACV-AAC valve	Full open
			Replace ECM, if ECM fail-safe condition is confirmed.	

\*1: In Diagnostic Test Mode II (Self-diagnostic results)

# TROUBLE DIAGNOSIS — GENERAL DESCRIPTION

Symptom Matrix Chart

## Symptom Matrix Chart SYSTEM — BASIC ENGINE CONTROL SYSTEM

NEEC0040

NEEC0040S01

		SYMPTOM												Reference page	
		HARD/NO START/RESTART (EXCP. HA)	ENGINE STALL	HESITATION/SURGING/FLAT SPOT	SPARK KNOCK/DETONATION	LACK OF POWER/POOR ACCELERATION	HIGH IDLE/LOW IDLE	ROUGH IDLE/HUNTING	IDLING VIBRATION	SLOW/NO RETURN TO IDLE	OVERHEATS/WATER TEMPERATURE HIGH	EXCESSIVE FUEL CONSUMPTION	EXCESSIVE OIL CONSUMPTION		BATTERY DEAD (UNDER CHARGE)
Warranty symptom code		AA	AB	AC	AD	AE	AF	AG	AH	AJ	AK	AL	AM	HA	
Fuel	Fuel pump circuit	1	1	2	3	2		3	2			3		1	EC-467
	Injector circuit							2							EC-460
	Fuel pressure regulator system														EC-32
	Evaporative emission system	4	4	4	4	4	4	4	3	3		4			EC-24
Air	Positive crankcase ventilation system												1		EC-30
	Incorrect idle speed adjustment	3	3				1	1	1	1		1			EC-35
	IACV-AAC valve circuit		1				2	2						1	EC-335
	IACV-FICD solenoid valve circuit	2	2	3	3	3	3	3	2	2		3			EC-478
Ignition	Incorrect ignition timing adjustment	3	3	1	1	1		1	1			1			EC-35
	Ignition circuit	1	1	2	2	2		2	2			2			EC-366
EGR	EGRC-solenoid valve circuit		2	2	3	3						3			EC-377
	EGR system	4	4	4	4	4	4	4	3	3		4			EC-288, 389
Main power supply and ground circuit		1									1				EC-116
Air conditioner circuit		2	2	3	3	3	3	3	2	2		3		1	HA section

1 - 6: The numbers refer to the order of inspection.  
(continued on next page)

GI  
 MA  
 EM  
 LC  
**EC**  
 FE  
 CL  
 MT  
 AT  
 TF  
 PD  
 FA  
 RA  
 BR  
 ST  
 RS  
 BT  
 HA  
 EL  
 IDX

# TROUBLE DIAGNOSIS — GENERAL DESCRIPTION

Symptom Matrix Chart (Cont'd)

	SYMPTOM												Reference page	
	HARD/NO START/RESTART (EXCP. HA)	ENGINE STALL	HESITATION/SURGING/FLAT SPOT	SPARK KNOCK/DETONATION	LACK OF POWER/POOR ACCELERATION	HIGH IDLE/LOW IDLE	ROUGH IDLE/HUNTING	IDLING VIBRATION	SLOW/NO RETURN TO IDLE	OVERHEATS/WATER TEMPERATURE HIGH	EXCESSIVE FUEL CONSUMPTION	EXCESSIVE OIL CONSUMPTION		BATTERY DEAD (UNDER CHARGE)
Warranty symptom code	AA	AB	AC	AD	AE	AF	AG	AH	AJ	AK	AL	AM	HA	
Camshaft position sensor circuit	1			2				2						EC-281
Mass air flow sensor circuit		1	2		2						2			EC-121
Front heated oxygen sensor circuit				3			2							EC-166
Engine coolant temperature sensor circuit	1	2	3		3	3			2		3			EC-145, 161
Throttle position sensor circuit		1	2		2	2					2			EC-150
Incorrect throttle position sensor adjustment		3	1		1	1	1	1	1		1			EC-86
Vehicle speed sensor circuit		2												EC-330
Knock sensor circuit			3	3	3						3			EC-271
ECM	2	2		3		3	3	2	2	1				EC-352, 96
Start signal circuit	1													EC-464
Park/neutral position (PNP) switch circuit			3		3			3			3			EC-442
Power steering oil pressure switch circuit		2						2						EC-473

1 - 6: The numbers refer to the order of inspection.  
(continued on next page)



# TROUBLE DIAGNOSIS — GENERAL DESCRIPTION

Symptom Matrix Chart (Cont'd)

## SYSTEM — ENGINE MECHANICAL & OTHER

NEEC0040803

		SYMPTOM												Reference section	
		HARD/NO START/RESTART (EXCP. HA)	ENGINE STALL	HESITATION/SURGING/FLAT SPOT	SPARK KNOCK/DETONATION	LACK OF POWER/POOR ACCELERATION	HIGH IDLE/LOW IDLE	ROUGH IDLE/HUNTING	IDLING VIBRATION	SLOW/NO RETURN TO IDLE	OVERHEATS/WATER TEMPERATURE HIGH	EXCESSIVE FUEL CONSUMPTION	EXCESSIVE OIL CONSUMPTION		BATTERY DEAD (UNDER CHARGE)
Warranty symptom code		AA	AB	AC	AD	AE	AF	AG	AH	AJ	AK	AL	AM	HA	
Fuel	Fuel tank	5													FE section
	Fuel piping			5	5	5		5	4			5			
	Vapor lock		5												
	Valve deposit														
	Poor fuel (Heavy weight gasoline, Low octane)	5		5	5	5		5	4			5			
Air	Air duct														FE section
	Air cleaner														
	Air leakage from air duct (Mass air flow sensor — throttle body)		5	5	5	5		5	4			5			
	Throttle body, Throttle wire	5					5			4					
	Air leakage from intake manifold/Collector/Gasket				5										
Cranking	Battery		1	1		1		1	1			1	1	EL section	
	Generator circuit														
	Starter circuit	1													
	Park/neutral position (PNP) switch														
	Drive plate/Flywheel	6													

1 - 6: The numbers refer to the order of inspection.  
(continued on next page)

GI  
 MA  
 EM  
 LC  
**EC**  
 FE  
 CL  
 MT  
 AT  
 TF  
 PD  
 FA  
 RA  
 BR  
 ST  
 RS  
 BT  
 HA  
 EL  
 IDX

# TROUBLE DIAGNOSIS — GENERAL DESCRIPTION

Symptom Matrix Chart (Cont'd)

		SYMPTOM												Reference section	
		HARD/NO START/RESTART (EXCP. HA)	ENGINE STALL	HESITATION/SURGING/FLAT SPOT	SPARK KNOCK/DETONATION	LACK OF POWER/POOR ACCELERATION	HIGH IDLE/LOW IDLE	ROUGH IDLE/HUNTING	IDLING VIBRATION	SLOW/NO RETURN TO IDLE	OVERHEATS/WATER TEMPERATURE HIGH	EXCESSIVE FUEL CONSUMPTION	EXCESSIVE OIL CONSUMPTION		BATTERY DEAD (UNDER CHARGE)
Warranty symptom code		AA	AB	AC	AD	AE	AF	AG	AH	AJ	AK	AL	AM	HA	
Engine	Cylinder head	5	5	5	5	5		5	5			5			EM section
	Cylinder head gasket										2	2			
	Cylinder block												3		
	Piston														
	Piston ring	6	6	6	6	6		6	6			6			
	Connecting rod														
	Bearing														
	Crankshaft														
Valve mechanism	Timing chain														EM section
	Camshaft	6													
	Intake valve		6	6	6	6		6	6			6	2		
	Exhaust valve														
	Hydraulic lash adjuster														
Exhaust	Exhaust manifold/Tube/Muffler/Gasket	6	6	6	6	6		6	6			6		FE section	
	Three way catalyst														
Lubrication	Oil pan/Oil strainer/Oil pump/Oil filter/Oil gallery	6	6	6	6	6		6	6			6	2	MA, EM, LC section	
	Oil level (Low)/Filthy oil													MA section	
Cooling	Radiator/Hose/Radiator filler cap													LC section	
	Thermostat						5			5					
	Water pump														
	Water gallery	6	6	6	6	6		6	6		2	6			
	Cooling fan												5		
	Coolant level (low)/Contaminated coolant														MA section

1 - 6: The numbers refer to the order of inspection.

# TROUBLE DIAGNOSIS — GENERAL DESCRIPTION

CONSULT Reference Value in Data Monitor Mode

## CONSULT Reference Value in Data Monitor Mode

NEEC0041

**Remarks:**

- Specification data are reference values.
- Specification data are output/input values which are detected or supplied by the ECM at the connector.
- \* Specification data may not be directly related to their components signals/values/operations.

i.e. Adjust ignition timing with a timing light before monitoring IGN TIMING, because the monitor may show the specification data in spite of the ignition timing not being adjusted to the specification data. This IGN TIMING monitors the data calculated by the ECM according to the signals input from the camshaft position sensor and other ignition timing related sensors.

- If the real-time diagnosis results are NG and the on board diagnostic system results are OK when diagnosing the mass air flow sensor, first check to see if the fuel pump control circuit is normal.

MONITOR ITEM	CONDITION		SPECIFICATION
CMPS-RPM (POS) CMPS-RPM (REF)	<ul style="list-style-type: none"> <li>• Tachometer: Connect</li> <li>• Run engine and compare tachometer indication with the CONSULT value.</li> </ul>		Almost the same speed as the CONSULT value.
MAS AIR/FL SE	<ul style="list-style-type: none"> <li>• Engine: After warming up</li> <li>• Air conditioner switch: "OFF"</li> <li>• Shift lever: "N"</li> <li>• No-load</li> </ul>	idle	1.0 - 1.7V
		2,500 rpm	1.7 - 2.3V
COOLAN TEMP/S	<ul style="list-style-type: none"> <li>• Engine: After warming up</li> </ul>		More than 70°C (158°F)
FR O2 SEN-B2 FR O2 SEN-B1	<ul style="list-style-type: none"> <li>• Engine: After warming up</li> </ul>	Maintaining engine speed at 2,000 rpm	0 - 0.3V ↔ Approx. 0.6 - 1.0V
FR O2 MNTR-B2 FR O2 MNTR-B1			LEAN ↔ RICH Changes more than 5 times during 10 seconds.
RR O2 SEN-B1 RR O2 SEN-B2	<ul style="list-style-type: none"> <li>• Engine: After warming up</li> </ul>	Maintaining engine speed at 2,000 rpm	0 - 0.3V ↔ Approx. 0.6 - 1.0V
RR O2 MNTR-B1 RR O2 MNTR-B2			LEAN ↔ RICH
VHCL SPEED SE	<ul style="list-style-type: none"> <li>• Turn drive wheels and compare speedometer indication with the CONSULT value</li> </ul>		Almost the same speed as the CONSULT value
BATTERY VOLT	<ul style="list-style-type: none"> <li>• Ignition switch: ON (Engine stopped)</li> </ul>		11 - 14V
THRTL POS SEN	<ul style="list-style-type: none"> <li>• Engine: After warming up, idle the engine</li> </ul>	Throttle valve: fully closed	0.4 - 0.6V
	<ul style="list-style-type: none"> <li>• Engine: After warming up</li> <li>• Ignition switch: ON (Engine stopped)</li> </ul>	Throttle valve: Partially open	0.5 - 0.7V
		Throttle valve: fully opened	Approx. 4.0V
EGR TEMP SEN	<ul style="list-style-type: none"> <li>• Engine: After warming up</li> </ul>		Less than 4.5V
START SIGNAL	<ul style="list-style-type: none"> <li>• Ignition switch: ON → START → ON</li> </ul>		OFF → ON → OFF
CLSD THL POS CLSD THL/P SW	<ul style="list-style-type: none"> <li>• Engine: After warming up, idle the engine</li> </ul>	Throttle valve: Idle position	ON
		Throttle valve: Slightly open	OFF
AIR COND SIG	<ul style="list-style-type: none"> <li>• Engine: After warming up, idle the engine</li> </ul>	Air conditioner switch: "OFF"	OFF
		Air conditioner switch: "ON" (Compressor operates.)	ON
P/N POSI SW	<ul style="list-style-type: none"> <li>• Ignition switch: ON</li> </ul>	Shift lever: "P" or "N"	ON
		Except above	OFF
PW/ST SIGNAL	<ul style="list-style-type: none"> <li>• Engine: After warming up, idle the engine</li> </ul>	Steering wheel in neutral position (forward direction)	OFF
		The steering wheel is turned	ON

## TROUBLE DIAGNOSIS — GENERAL DESCRIPTION

CONSULT Reference Value in Data Monitor Mode (Cont'd)

MONITOR ITEM	CONDITION	SPECIFICATION
AMB TEMP SW	<ul style="list-style-type: none"> <li>Ignition switch: ON</li> <li>Compare ambient air temperature with the following:</li> </ul>	Below 19°C (66°F)
		Above 25°C (77°F)
IGNITION SW	<ul style="list-style-type: none"> <li>Ignition switch: ON → OFF → ON</li> </ul>	ON → OFF → ON
INJ PULSE-B2 INJ PULSE-B1	<ul style="list-style-type: none"> <li>Engine: After warming up</li> <li>Air conditioner switch: "OFF"</li> <li>Shift lever: "N"</li> <li>No-load</li> </ul>	Idle
		2,000 rpm
B/FUEL SCHDL	<ul style="list-style-type: none"> <li>Engine: After warming up</li> <li>Air conditioner switch: "OFF"</li> <li>Shift lever: "N"</li> <li>No-load</li> </ul>	Idle
		2,000 rpm
IGN TIMING	<ul style="list-style-type: none"> <li>Engine: After warming up</li> <li>Air conditioner switch: "OFF"</li> <li>Shift lever: "N"</li> <li>No-load</li> </ul>	Idle
		2,000 rpm
IACV-AAC/V	<ul style="list-style-type: none"> <li>Engine: After warming up</li> <li>Air conditioner switch: "OFF"</li> <li>Shift lever: "N"</li> <li>No-load</li> </ul>	Idle
		2,000 rpm
PURG VOL C/V	<ul style="list-style-type: none"> <li>Engine: After warming up</li> <li>Air conditioner switch: "OFF"</li> <li>Shift lever: "N"</li> <li>No-load</li> </ul>	Idle
		2,000 rpm
A/F ALPHA-B2 A/F ALPHA-B1	<ul style="list-style-type: none"> <li>Engine: After warming up</li> </ul>	Maintaining engine speed at 2,000 rpm
EVAP SYS PRES	<ul style="list-style-type: none"> <li>Ignition switch: ON</li> </ul>	Approx. 3.4V
AIR COND RLY	<ul style="list-style-type: none"> <li>Air conditioner switch: OFF → ON</li> </ul>	OFF → ON
FUEL PUMP RLY	<ul style="list-style-type: none"> <li>Ignition switch is turned to ON (Operates for 5 seconds)</li> <li>Engine running and cranking</li> </ul>	ON
	Except as shown above	OFF
COOLING FAN	<ul style="list-style-type: none"> <li>After warming up engine, idle the engine.</li> <li>Air conditioner switch: "OFF"</li> </ul>	Engine coolant temperature is 94°C (201°F) or less
		Engine coolant temperature is 95°C (203°F) or more
EGRC SOL/V	<ul style="list-style-type: none"> <li>Engine: After warming up</li> <li>Air conditioner switch: "OFF"</li> <li>Shift lever: "N"</li> <li>No-load</li> </ul>	Idle
		Engine speed: Revving from idle up to 3,000 rpm quickly
VENT CONT/V	<ul style="list-style-type: none"> <li>Ignition switch: ON</li> </ul>	OFF
FR O2 HTR-B1 FR O2 HTR-B2	<ul style="list-style-type: none"> <li>Engine speed: Below 3,200 rpm</li> </ul>	ON
	<ul style="list-style-type: none"> <li>Engine speed: Above 3,200 rpm</li> </ul>	OFF
RR O2 HTR-B1 RR O2 HTR-B2	<ul style="list-style-type: none"> <li>Ignition switch: ON (Engine stopped)</li> <li>Engine speed: Above 3,200 rpm</li> </ul>	OFF
	<ul style="list-style-type: none"> <li>Engine speed: Below 3,200 rpm [After driving for 2 minutes at a speed of 70 km/h (43 MPH) or more]</li> </ul>	ON
VC/V BYPASS/V	<ul style="list-style-type: none"> <li>Ignition switch: ON</li> </ul>	OFF

# TROUBLE DIAGNOSIS — GENERAL DESCRIPTION

*CONSULT Reference Value in Data Monitor Mode (Cont'd)*

MONITOR ITEM	CONDITION	SPECIFICATION	
CAL/LD VALUE	<ul style="list-style-type: none"> <li>• Engine: After warming up</li> <li>• Air conditioner switch: "OFF"</li> <li>• Shift lever: "N"</li> <li>• No-load</li> </ul>	Idle 18.5 - 26.0%	
		2,500 rpm 18.0 - 21.0%	
ABSOL TH-P/S	<ul style="list-style-type: none"> <li>• Engine: After warming up</li> </ul>	Throttle valve: fully closed 0.0%	
	<ul style="list-style-type: none"> <li>• Engine: After warming up</li> <li>• Ignition switch: ON (Engine stopped)</li> </ul>	Throttle valve: fully opened Approx. 80%	
MASS AIRFLOW	<ul style="list-style-type: none"> <li>• Engine: After warming up</li> <li>• Air conditioner switch: "OFF"</li> <li>• Shift lever: "N"</li> <li>• No-load</li> </ul>	Idle 3.3 - 4.8 g-m/s	
		2,500 rpm 12.0 - 14.9 g-m/s	
MAP/BARO SW/V	<ul style="list-style-type: none"> <li>• Ignition switch: ON (Engine stopped)</li> </ul>	MAP	
	<ul style="list-style-type: none"> <li>• Engine speed: Idle</li> </ul>	For 5 seconds after starting engine	BARO
		More than 5 seconds after starting engine	MAP
ABSOL PRES/SE	<ul style="list-style-type: none"> <li>• Ignition switch: ON (Engine stopped)</li> </ul>	Approx. 4.4V	
	<ul style="list-style-type: none"> <li>• Engine speed: Idle</li> </ul>	For 5 seconds after starting engine	Approx. 4.4V
		More than 5 seconds after starting engine	Approx. 1.3V

## Major Sensor Reference Graph in Data Monitor Mode

The following are the major sensor reference graphs in "DATA MONITOR" mode.  
(Select "HI SPEED" in "DATA MONITOR" with CONSULT.)

NEEC0042

### THRTL POS SEN, ABSOL TH-P/S, CLSD THL POS

Below is the data for "THRTL POS SEN", "ABSOL TH-P/S" and "CLSD THL POS" when depressing the accelerator pedal with the ignition switch "ON".

NEEC0042S01

The signal of "THRTL POS SEN" and "ABSOL TH-P/S" should rise gradually without any intermittent drop or rise after "CLSD THL POS" is changed from "ON" to "OFF".

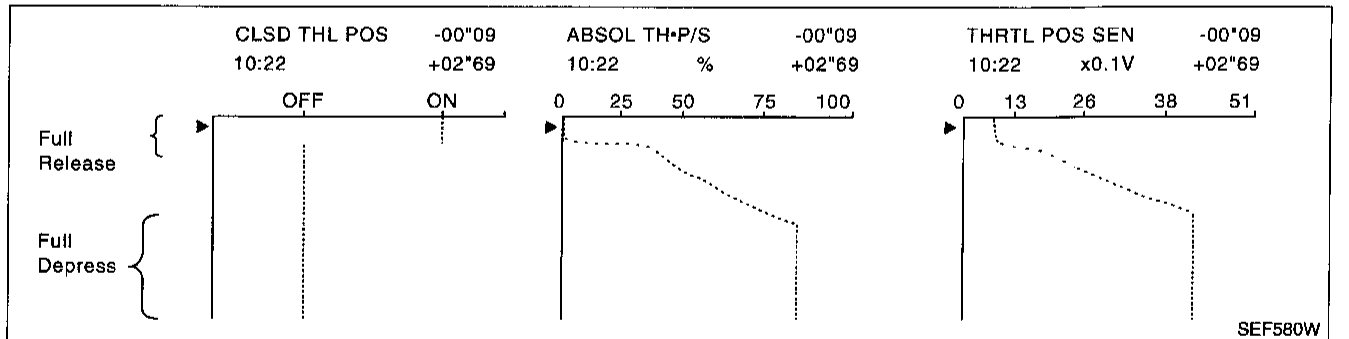

SEF580W

### CMPS-RPM (REF), MAS AIR/FL SE, THRTL POS SEN, RR O2 SEN-B1, FR O2 SEN-B1, INJ PULSE-B1

Below is the data for "CMPS-RPM (REF)", "MAS AIR/FL SE", "THRTL POS SEN", "RR O2 SEN-B1", "FR O2 SEN-B1" and "INJ PULSE-B1" when revving engine quickly up to 4,800 rpm under no load after warming up engine sufficiently.

NEEC0042S02

Each value is for reference, the exact value may vary.

# TROUBLE DIAGNOSIS — GENERAL DESCRIPTION

Major Sensor Reference Graph in Data Monitor Mode (Cont'd)

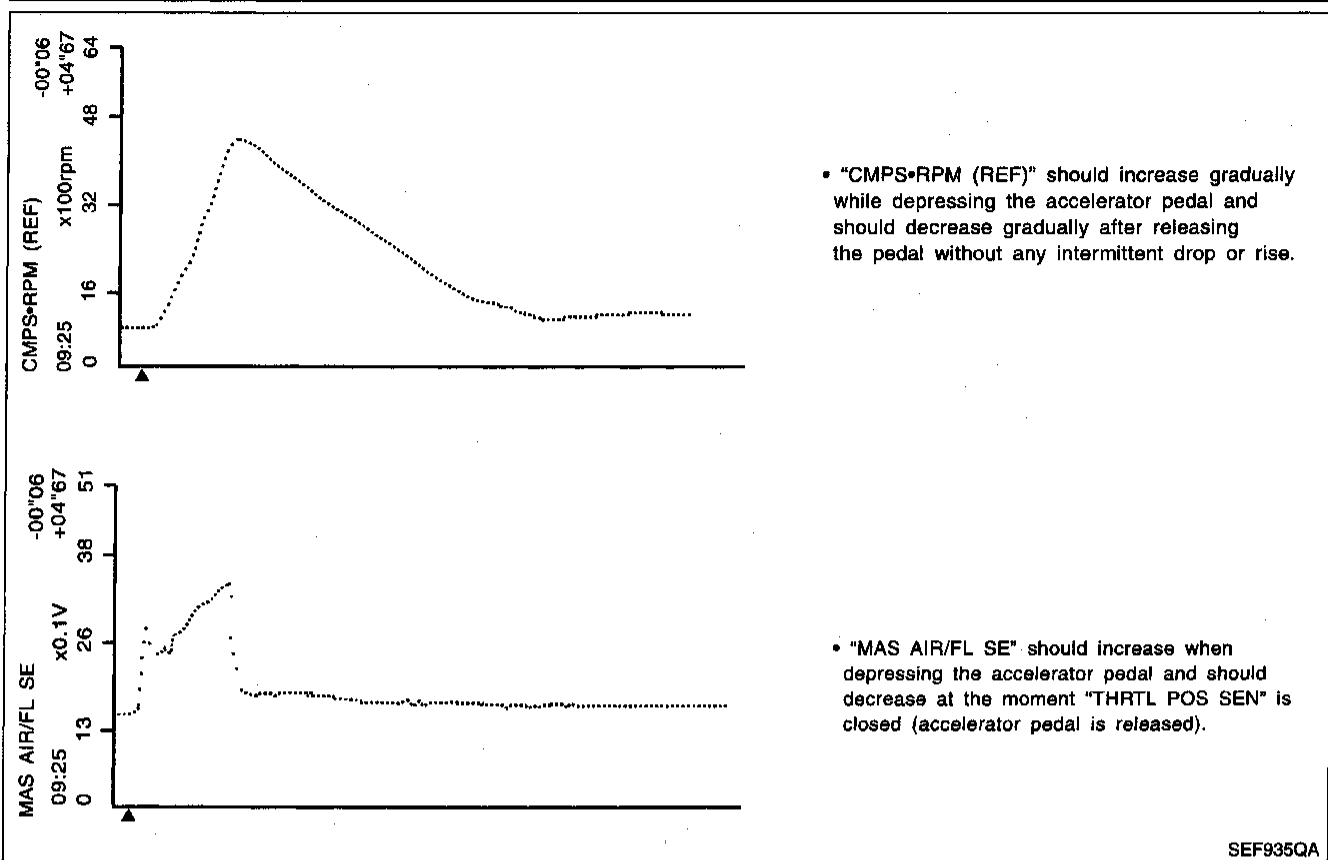

# TROUBLE DIAGNOSIS — GENERAL DESCRIPTION

Major Sensor Reference Graph in Data Monitor Mode (Cont'd)

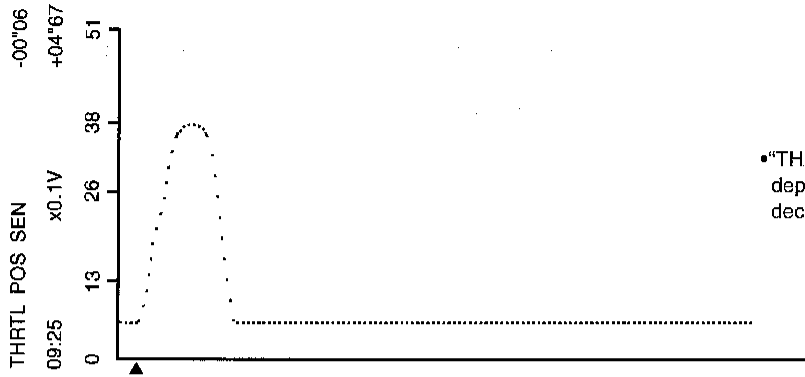

•“THRTL POS SEN” should increase while depressing the accelerator pedal and should decrease while releasing it.

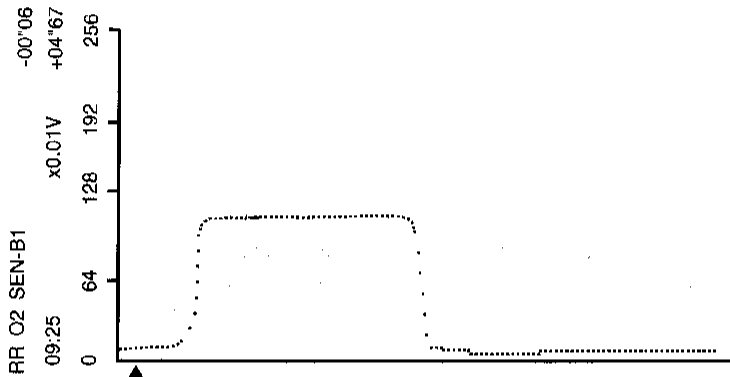

•“RR O2 SEN-B1” may increase immediately after depressing the accelerator pedal and may decrease after releasing the pedal.

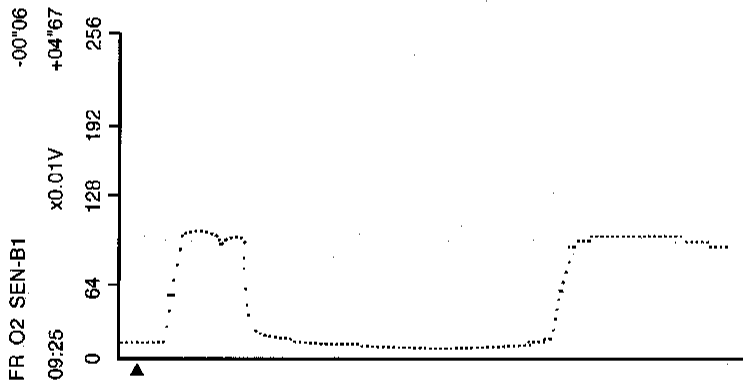

•“FR O2 SEN-B1” may increase immediately after depressing the accelerator pedal and may decrease after releasing the pedal.

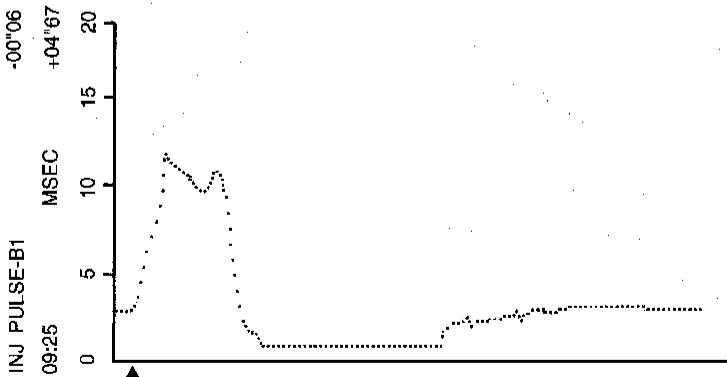

•“INJ PULSE-B1” should increase when depressing the accelerator pedal and should decrease when the pedal is released.

GI  
MA  
EM  
LC  
**EC**  
FE  
CL  
MT  
AT  
TF  
PD  
FA  
RA  
BR  
ST  
RS  
BT  
HA  
EL  
IDX

SEF936Q

# TROUBLE DIAGNOSIS — GENERAL DESCRIPTION

## ECM Terminals and Reference Value

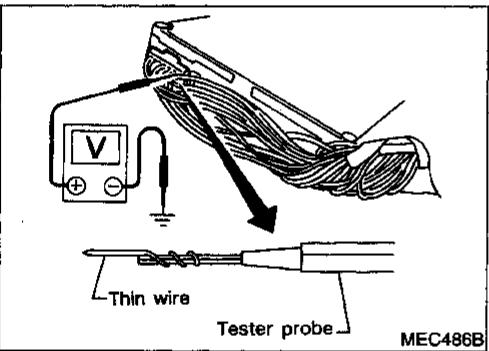
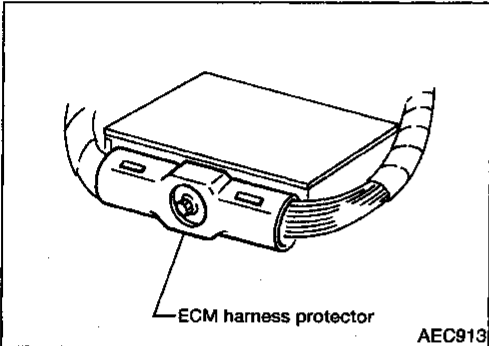
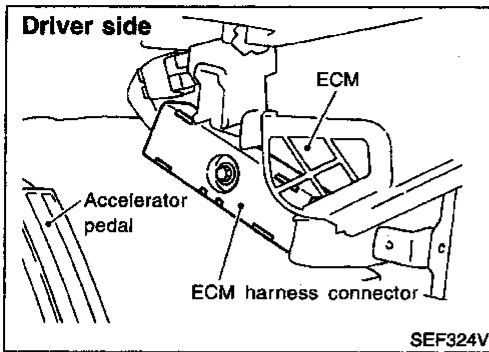

## ECM Terminals and Reference Value

NEEC0043

### PREPARATION

NEEC0043S01

1. ECM is located behind the instrument lower cover. For this inspection:
  - Remove instrument lower cover.
2. Remove ECM harness protector.
3. Perform all voltage measurements with the connector connected. Extend tester probe as shown to perform tests easily.
  - Open harness securing clip to make testing easier.
  - Use extreme care not to touch 2 pins at one time.
  - Data is for comparison and may not be exact.

## ECM HARNESS CONNECTOR TERMINAL LAYOUT

NEEC0043S02

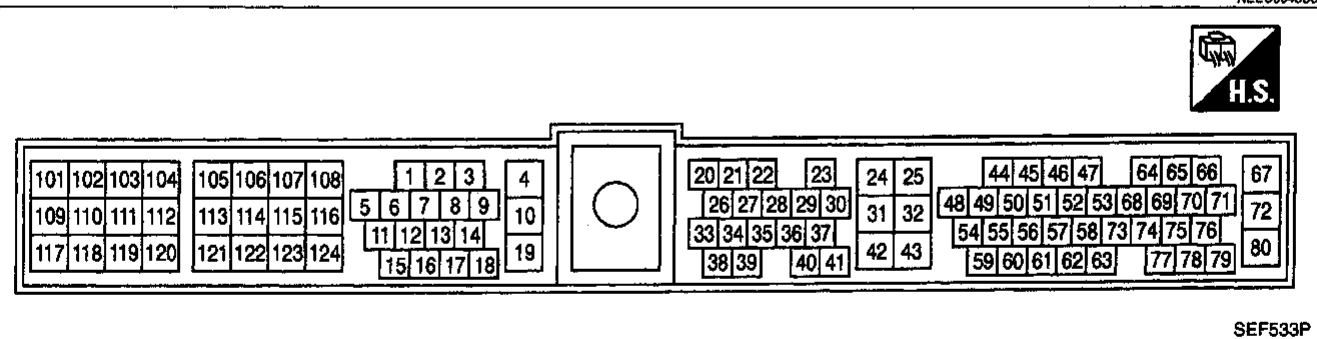

## ECM INSPECTION TABLE

NEEC0043S03

Specification data are reference values and are measured between each terminal and 32 (ECM ground).



# TROUBLE DIAGNOSIS — GENERAL DESCRIPTION

*ECM Terminals and Reference Value (Cont'd)*

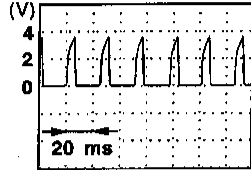
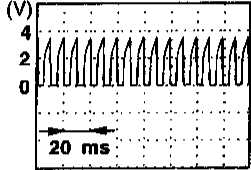
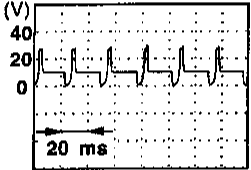
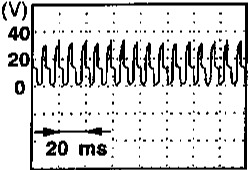
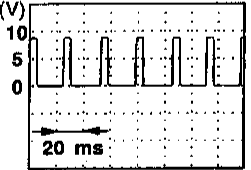
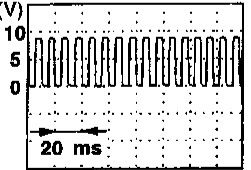
TERMI- NAL NO.	WIRE COLOR	ITEM	CONDITION	DATA (DC Voltage)
1	PU/W	Ignition signal	<p><b>[Engine is running]</b></p> <ul style="list-style-type: none"> <li>• Idle speed</li> </ul>	<p>Approximately 0.7V</p> 
			<p><b>[Engine is running]</b></p> <ul style="list-style-type: none"> <li>• Engine speed is 2,000 rpm</li> </ul>	<p>1.1 - 1.5V</p> 
2	B	Ignition check	<p><b>[Engine is running]</b></p> <ul style="list-style-type: none"> <li>• Warm-up condition</li> <li>• Idle speed</li> </ul>	<p>Approximately 12V</p> 
			<p><b>[Engine is running]</b></p> <ul style="list-style-type: none"> <li>• Engine speed is 2,000 rpm</li> </ul>	<p>Approximately 11V</p> 
3	R/L	Tachometer	<p><b>[Engine is running]</b></p> <ul style="list-style-type: none"> <li>• Warm-up condition</li> <li>• Idle speed</li> </ul>	<p>1 - 2V</p> 
			<p><b>[Engine is running]</b></p> <ul style="list-style-type: none"> <li>• Engine speed is 2,000 rpm</li> </ul>	<p>3 - 5V</p> 

GI  
MA  
EM  
LC  
**EC**  
FE  
CL  
MT  
AT  
TF  
PD  
FA  
RA  
BR  
ST  
RS  
BT  
HA  
EL  
IDX

## TROUBLE DIAGNOSIS — GENERAL DESCRIPTION

ECM Terminals and Reference Value (Cont'd)

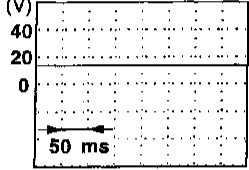
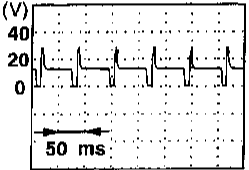
TERMI- NAL NO.	WIRE COLOR	ITEM	CONDITION	DATA (DC Voltage)
4	OR/B	ECM relay (Self shut-off)	<b>[Engine is running]</b> <b>[Ignition switch "OFF"]</b> <ul style="list-style-type: none"> <li>For a few seconds after turning ignition switch "OFF"</li> </ul>	0 - 1.5V
			<b>[Ignition switch "OFF"]</b> <ul style="list-style-type: none"> <li>A few seconds passed after turning ignition switch "OFF"</li> </ul>	BATTERY VOLTAGE (11 - 14V)
5	R/Y	EVAP canister purge volume control solenoid valve	<b>[Engine is running]</b> <ul style="list-style-type: none"> <li>Idle speed</li> </ul>	BATTERY VOLTAGE (11 - 14V) 
			<b>[Engine is running]</b> <ul style="list-style-type: none"> <li>Engine speed is 2,000 rpm (More than 100 seconds after starting engine)</li> </ul>	BATTERY VOLTAGE (11 - 14V) 
7	Y/G	A/T check signal	<b>[Ignition switch "ON"]</b> <b>[Engine is running]</b>	0 - 3.0V
9	B/Y	Ambient air temperature switch	<b>[Engine is running]</b> <ul style="list-style-type: none"> <li>Idle speed</li> <li>Ambient air temperature is above 25°C (77°F)</li> <li>Air conditioner is operating</li> </ul>	0V
			<b>[Engine is running]</b> <ul style="list-style-type: none"> <li>Idle speed</li> <li>Ambient air temperature is below 19°C (66°F)</li> <li>Air conditioner is operating</li> </ul>	BATTERY VOLTAGE (11 - 14V)
			<b>[Engine is running]</b> <ul style="list-style-type: none"> <li>Idle speed</li> <li>Ambient air temperature is below 19°C (66°F)</li> <li>Air conditioner is not operating</li> </ul>	Approximately 5V
10	B/R	ECM ground	<b>[Engine is running]</b> <ul style="list-style-type: none"> <li>Idle speed</li> </ul>	Engine ground
11	W/R	Fuel pump relay	<b>[Ignition switch "ON"]</b> <ul style="list-style-type: none"> <li>For 5 seconds after turning ignition switch "ON"</li> </ul> <b>[Engine is running]</b>	0 - 1V
			<b>[Ignition switch "ON"]</b> <ul style="list-style-type: none"> <li>More than 5 seconds after turning ignition switch "ON"</li> </ul>	BATTERY VOLTAGE (11 - 14V)
12	P	Air conditioner relay	<b>[Engine is running]</b> <ul style="list-style-type: none"> <li>Both A/C switch and blower switch are "ON"</li> </ul>	0 - 1V
			<b>[Engine is running]</b> <ul style="list-style-type: none"> <li>A/C switch is "OFF"</li> </ul>	BATTERY VOLTAGE (11 - 14V)

# TROUBLE DIAGNOSIS — GENERAL DESCRIPTION

*ECM Terminals and Reference Value (Cont'd)*

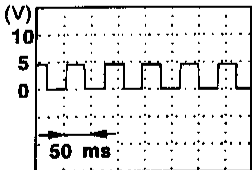
TERMI- NAL NO.	WIRE COLOR	ITEM	CONDITION	DATA (DC Voltage)
18	R/W	Malfunction indicator lamp	[Ignition switch "ON"]	0 - 1V
			[Engine is running] • Idle speed	BATTERY VOLTAGE (11 - 14V)
19	B/R	ECM ground	[Engine is running] • Idle speed	Engine ground
20	L/OR	Start signal	[Ignition switch "ON"]	Approximately 0V
			[Ignition switch "START"]	9 - 12V
21	G/R	Air conditioner switch	[Engine is running] • Both A/C switch and blower switch are "ON" (Compressor operates)*	Approximately 0V
			[Engine is running] • A/C switch is "OFF"	BATTERY VOLTAGE (11 - 14V)
22	L/B	Park/neutral position (PNP) switch	[Ignition switch "ON"] • Gear position is "N" or "P"	Approximately 0V
			[Ignition switch "ON"] • Except the above gear position	Approximately 5V
23	L	Throttle position sensor	[Engine is running] • Warm-up condition • Accelerator pedal fully released	0.4 - 0.6V
			[Ignition switch "ON"] • Accelerator pedal fully depressed	Approximately 4V
24	W/L	Ignition switch	[Ignition switch "OFF"]	0V
			[Ignition switch "ON"]	BATTERY VOLTAGE (11 - 14V)
25	B/Y	ECM ground	[Engine is running] • Idle speed	Engine ground
26	PU/W	A/T signal No. 1	[Ignition switch "ON"] [Engine is running] • Idle speed	6 - 8V
27	P/B	A/T signal No. 2	[Ignition switch "ON"] [Engine is running] • Idle speed	6 - 8V
28	BR/W	Throttle position switch (Closed position)	[Engine is running] • Warm-up condition • Accelerator pedal fully released	BATTERY VOLTAGE (11 - 14V)
			[Ignition switch "ON"] • Accelerator pedal depressed	Approximately 0V
29	G/B	Vehicle speed sensor	[Engine is running] • Lift up the vehicle. • In 2nd gear position • Vehicle speed is 40 km/h (25 MPH)	2 - 3V 

SEF996U

GI  
MA  
EM  
LC  
EC  
FE  
CL  
MT  
AT  
TF  
PD  
FA  
RA  
BR  
ST  
RS  
BT  
HA  
EL  
IDX

## TROUBLE DIAGNOSIS — GENERAL DESCRIPTION

ECM Terminals and Reference Value (Cont'd)

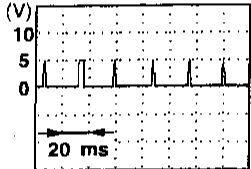
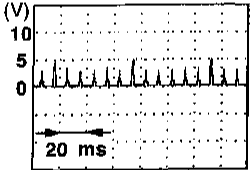
TERMI- NAL NO.	WIRE COLOR	ITEM	CONDITION	DATA (DC Voltage)
32	B/Y	ECM ground	<b>[Engine is running]</b> • Idle speed	Engine ground (Probe this terminal with (-) tester probe when measuring)
35	G/R	A/T signal No. 3	<b>[Ignition switch "ON"]</b>	0V
36	LG/R	Cooling fan relay	<b>[Engine is running]</b> • Cooling fan is not operating	BATTERY VOLTAGE (11 - 14V)
			<b>[Engine is running]</b> • Cooling fan is operating	0 - 1V
39	GY/R	Power steering oil pressure switch	<b>[Engine is running]</b> • Steering wheel is being turned	Approximately 0V
			<b>[Engine is running]</b> • Steering wheel is not being turned	Approximately 5V
42	B/W	Sensors' power supply	<b>[Ignition switch "ON"]</b>	Approximately 5V
43	BR	Sensors' ground	<b>[Engine is running]</b> • Warm-up condition • Idle speed	Approximately 0V
44 48	PU PU	Camshaft position sen- sor (Reference signal)	<b>[Engine is running]</b> • Idle speed	0.3 - 0.5V  SEF997U
			<b>[Engine is running]</b> • Engine speed is 2,000 rpm	0.3 - 0.5V  SEF998U
45	B/R	Absolute pressure sen- sor	<b>[Ignition switch "ON"]</b> • Engine is not running	Approximately 4.4V
			<b>[Engine is running]</b> • Idle (for 5 seconds after engine start)	
			<b>[Engine is running]</b> • Idle (More than 5 seconds after engine start)	Approximately 1.3V

# TROUBLE DIAGNOSIS — GENERAL DESCRIPTION

*ECM Terminals and Reference Value (Cont'd)*

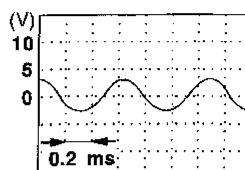
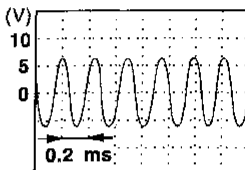
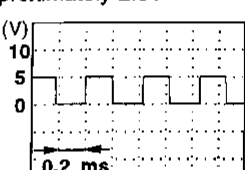
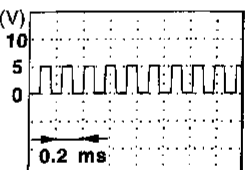
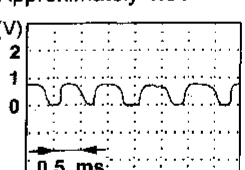
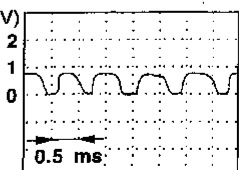
TERMI- NAL NO.	WIRE COLOR	ITEM	CONDITION	DATA (DC Voltage)
47	L	Crankshaft position sensor (OBD)	<p><b>[Engine is running]</b></p> <ul style="list-style-type: none"> <li>• Warm-up condition</li> <li>• Idle speed</li> </ul>	<p>1 - 2V (AC range)</p>  <p style="text-align: right;">SEF690W</p>
			<p><b>[Engine is running]</b></p> <ul style="list-style-type: none"> <li>• Engine speed is 2,000 rpm</li> </ul>	<p>3 - 4V (AC range)</p>  <p style="text-align: right;">SEF691W</p>
49	LG	Camshaft position sen- sor (Position signal)	<p><b>[Engine is running]</b></p> <ul style="list-style-type: none"> <li>• Warm-up condition</li> <li>• Idle speed</li> </ul>	<p>Approximately 2.5V</p>  <p style="text-align: right;">SEF999U</p>
			<p><b>[Engine is running]</b></p> <ul style="list-style-type: none"> <li>• Engine speed is 2,000 rpm</li> </ul>	<p>Approximately 2.5V</p>  <p style="text-align: right;">SEF001V</p>
50	B	Front heated oxygen sensor RH	<p><b>[Engine is running]</b></p> <ul style="list-style-type: none"> <li>• Warm-up condition</li> <li>• Engine speed is 2,000 rpm</li> </ul>	<p>0 - Approximately 1.0V</p>  <p style="text-align: right;">SEF002V</p>
51	G	Front heated oxygen sensor LH	<p><b>[Engine is running]</b></p> <ul style="list-style-type: none"> <li>• Warm-up condition</li> <li>• Engine speed is 2,000 rpm</li> </ul>	<p>0 - Approximately 1.0V</p>  <p style="text-align: right;">SEF002V</p>

GI  
MA  
EM  
LC  
**EC**  
FE  
CL  
MT  
AT  
TF  
PD  
FA  
RA  
BR  
ST  
RS  
BT  
HA  
EL  
IDX

## TROUBLE DIAGNOSIS — GENERAL DESCRIPTION

ECM Terminals and Reference Value (Cont'd)

TERMI- NAL NO.	WIRE COLOR	ITEM	CONDITION	DATA (DC Voltage)
54	R	Mass air flow sensor	[Engine is running] • Warm-up condition • Idle speed	1.0 - 1.7V
			[Engine is running] • Warm-up condition • Engine speed is 2,500 rpm	1.7 - 2.3V
55	G	Mass air flow sensor ground	[Engine is running] • Warm-up condition • Idle speed	Approximately 0V
56	OR	Rear heated oxygen sensor RH	[Engine is running] • Warm-up condition • Engine speed is 2,000 rpm	0 - Approximately 1.0V
57	Y	Rear heated oxygen sensor LH	[Engine is running] • Warm-up condition • Engine speed is 2,000 rpm	0 - Approximately 1.0V
59	LG/R	Engine coolant temperature sensor	[Engine is running]	Approximately 0 - 4.8V Output voltage varies with engine coolant temperature
60	Y/B	Tank fuel temperature sensor	[Engine is running]	Approximately 0 - 4.8V Output voltage varies with fuel temperature
61	PU/R	Intake air temperature sensor	[Engine is running]	Approximately 0 - 4.8V Output voltage varies with intake air temperature.
62	Y	EVAP control system pressure sensor	[Ignition switch "ON"]	Approximately 3.4V
63	G/OR	EGR temperature sensor	[Ignition switch "ON"]	Less than 4.5V
			[Engine is running] • Warm-up condition • EGR system is operating	0 - 1.5V
64	W	Knock sensor	[Engine is running] • Idle speed	Approximately 2.5V
67	B/P	Power supply for ECM	[Ignition switch "ON"]	BATTERY VOLTAGE (11 - 14V)
69	LG/R	Data link connector for GST	[Engine is running] • Idle speed (GST is disconnected)	6 - 10V
72	B/P	Power supply for ECM	[Ignition switch "ON"]	BATTERY VOLTAGE (11 - 14V)
75	Y/R	Data link connector for CONSULT	[Engine is running]	0 - 4V
76	GY/L		• Idle speed (Connect CONSULT and turned on.)	3 - 9V
80	SB	Power supply (Back-up)	[Ignition switch "OFF"]	BATTERY VOLTAGE (11 - 14V)

# TROUBLE DIAGNOSIS — GENERAL DESCRIPTION

*ECM Terminals and Reference Value (Cont'd)*

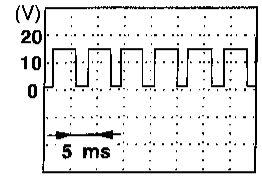
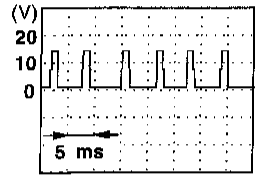
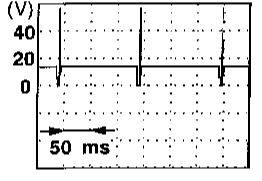
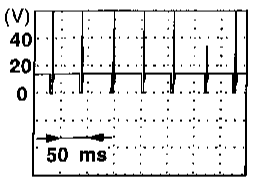
TERMI- NAL NO.	WIRE COLOR	ITEM	CONDITION	DATA (DC Voltage)
101	OR/L	IACV-AAC valve	<p><b>[Engine is running]</b></p> <ul style="list-style-type: none"> <li>• Warm-up condition</li> <li>• Idle speed</li> </ul>	<p>8 - 11V</p>  <p style="text-align: right; font-size: small;">SEF005V</p>
			<p><b>[Engine is running]</b></p> <ul style="list-style-type: none"> <li>• Warm-up condition</li> <li>• Engine speed is 3,000 rpm</li> </ul>	<p>7 - 10V</p>  <p style="text-align: right; font-size: small;">SEF692W</p>
102 104 106 109 111 113	W/B W/R W/G W/L W/PU W	Injector No. 1 Injector No. 3 Injector No. 5 Injector No. 2 Injector No. 4 Injector No. 6	<p><b>[Engine is running]</b></p> <ul style="list-style-type: none"> <li>• Warm-up condition</li> <li>• Idle speed</li> </ul>	<p>BATTERY VOLTAGE (11 - 14V)</p>  <p style="text-align: right; font-size: small;">SEF007V</p>
			<p><b>[Engine is running]</b></p> <ul style="list-style-type: none"> <li>• Warm-up condition</li> <li>• Engine speed is 2,000 rpm</li> </ul>	<p>BATTERY VOLTAGE (11 - 14V)</p>  <p style="text-align: right; font-size: small;">SEF008V</p>
103	G/W	EGRC-solenoid valve	<p><b>[Engine is running]</b></p> <ul style="list-style-type: none"> <li>• Warm-up condition</li> <li>• Idle speed</li> </ul>	<p>BATTERY VOLTAGE (11 - 14V)</p>
			<p><b>[Engine is running]</b></p> <ul style="list-style-type: none"> <li>• Warm-up condition</li> <li>• Engine speed is revving from idle up to 3,000 rpm quickly</li> </ul>	<p>0 - 1.5V</p>
108	R/G	EVAP canister vent control valve	<b>[Ignition switch "ON"]</b>	BATTERY VOLTAGE (11 - 14V)
116	B/R	ECM ground	<b>[Engine is running]</b>	Engine ground
117	B/P	Current return	<b>[Engine is running]</b>	BATTERY VOLTAGE (11 - 14V)

GI  
MA  
EM  
LC  
**EC**  
FE  
CL  
MT  
AT  
TF  
PD  
FA  
RA  
BR  
ST  
RS  
BT  
HA  
EL  
IDX

## TROUBLE DIAGNOSIS — GENERAL DESCRIPTION

ECM Terminals and Reference Value (Cont'd)

TERMI- NAL NO.	WIRE COLOR	ITEM	CONDITION	DATA (DC Voltage)
118	Y/B	MAP/BARO switch solenoid valve	<b>[Ignition switch "ON"]</b> <ul style="list-style-type: none"> <li>Engine is not running</li> <li>For 5 seconds after ignition switch is turned "ON"</li> </ul>	0 - 1V
			<b>[Engine is running]</b> <ul style="list-style-type: none"> <li>Idle (for 5 seconds after engine start)</li> </ul>	
119	BR/Y	Front heated oxygen sensor heater RH	<b>[Ignition switch "ON"]</b> <ul style="list-style-type: none"> <li>Engine is not running</li> <li>More than 5 seconds after ignition switch is turned "ON"</li> </ul>	BATTERY VOLTAGE (11 - 14V)
			<b>[Engine is running]</b> <ul style="list-style-type: none"> <li>Idle (More than 5 seconds after engine start)</li> </ul>	
120	P/B	Vacuum cut valve bypass valve	<b>[Ignition switch "ON"]</b>	BATTERY VOLTAGE (11 - 14V)
			<b>[Engine is running]</b> <ul style="list-style-type: none"> <li>Engine speed is below 3,200 rpm</li> </ul>	Approximately 0.4V
121	BR	Front heated oxygen sensor heater LH	<b>[Engine is running]</b> <ul style="list-style-type: none"> <li>Engine speed is above 3,200 rpm</li> </ul>	BATTERY VOLTAGE (11 - 14V)
			<b>[Engine is running]</b> <ul style="list-style-type: none"> <li>Engine speed is below 3,200 rpm</li> </ul>	Approximately 0.4V
122	R/B	Rear heated oxygen sensor heater RH	<b>[Engine is running]</b> <ul style="list-style-type: none"> <li>Engine speed is below 3,200 rpm</li> <li>After driving for 2 minutes at a speed of 70 km/h (43 MPH) or more.</li> </ul>	Approximately 0.4V
			<b>[Ignition switch "ON"]</b> <ul style="list-style-type: none"> <li>Engine stopped</li> </ul> <b>[Engine is running]</b> <ul style="list-style-type: none"> <li>Engine speed is above 3,200 rpm</li> </ul>	BATTERY VOLTAGE (11 - 14V)
123	R/Y	Rear heated oxygen sensor heater LH	<b>[Engine is running]</b> <ul style="list-style-type: none"> <li>Engine speed is below 3,200 rpm</li> <li>After driving for 2 minutes at a speed of 70 km/h (43 MPH) or more.</li> </ul>	Approximately 0.4V
			<b>[Ignition switch "ON"]</b> <ul style="list-style-type: none"> <li>Engine stopped</li> </ul> <b>[Engine is running]</b> <ul style="list-style-type: none"> <li>Engine speed is above 3,200 rpm</li> </ul>	BATTERY VOLTAGE (11 - 14V)
124	B/R	ECM ground	<b>[Engine is running]</b> <ul style="list-style-type: none"> <li>Idle speed</li> </ul>	Engine ground

\*: Any mode except "OFF", ambient air temperature is above 25°C (77°F).



# TROUBLE DIAGNOSIS FOR INTERMITTENT INCIDENT

Description

## Description

Intermittent incidents (I/I) may occur. In many cases, the problem resolves itself (the part or circuit function returns to normal without intervention). It is important to realize that the symptoms described in the customer's complaint often do not recur on (1st trip) DTC visits. Realize also that the most frequent cause of I/I occurrences is poor electrical connections. Because of this, the conditions under which the incident occurred may not be clear. Therefore, circuit checks made as part of the standard diagnostic procedure may not indicate the specific problem area.

NEEC0388

## COMMON I/I REPORT SITUATIONS

NEEC0388S01

STEP in Work Flow	Situation
II	The CONSULT is used. The SELF-DIAG RESULTS screen shows time data other than "0" or "[1]".
III	The symptom described by the customer does not recur.
IV	(1st trip) DTC does not appear during the DTC Confirmation Procedure.
VI	The Diagnostic Procedure for PXXXX does not indicate the problem area.

## Diagnostic Procedure

NEEC0389

<b>1</b>	<b>INSPECTION START</b>
Erase (1st trip) DTCs. Refer to "HOW TO ERASE EMISSION -- RELATED INFORMATION", EC-55.	
▶	GO TO 2.

<b>2</b>	<b>CHECK GROUND TERMINALS</b>
Check ground terminals for corroding or loose connection. Refer to "Circuit Inspection", "GROUND INSPECTION" in G1 section.	
OK or NG	
OK	▶ GO TO 3.
NG	▶ Repair or replace.

<b>3</b>	<b>SEARCH FOR ELECTRICAL INCIDENT</b>
Perform "Incident Simulation Tests" in G1 section.	
OK or NG	
OK	▶ GO TO 4.
NG	▶ Repair or replace.

<b>4</b>	<b>CHECK CONNECTOR TERMINALS</b>
Refer to "How to Check Enlarged Contact Spring of Terminal" in G1 section.	
OK or NG	
OK	▶ <b>INSPECTION END</b>
NG	▶ Repair or replace connector.

GI  
MA  
EM  
LC  
EC  
FE  
CL  
MT  
AT  
TF  
PD  
FA  
RA  
BR  
ST  
RS  
BT  
HA  
EL  
IDX

# TROUBLE DIAGNOSIS FOR POWER SUPPLY

Main Power Supply and Ground Circuit

## Main Power Supply and Ground Circuit WIRING DIAGRAM

NEEC0044

EC-MAIN-01

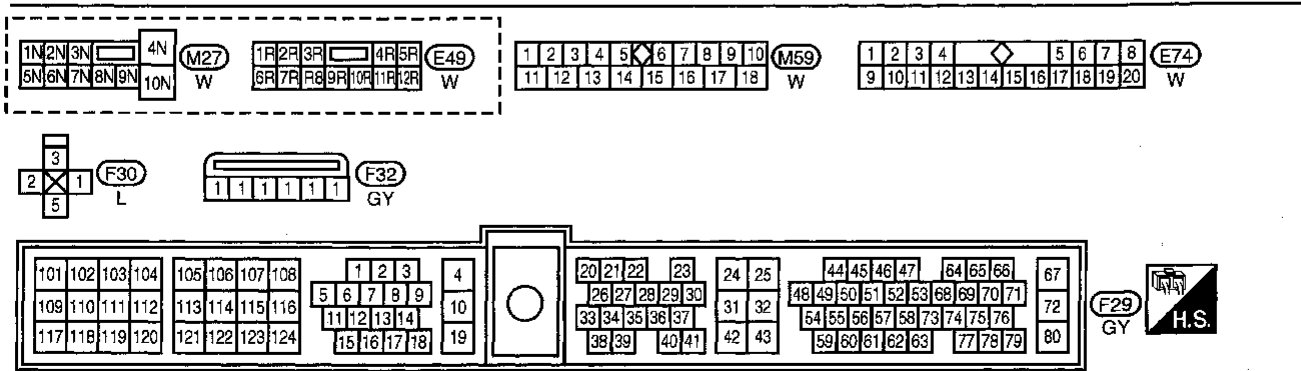
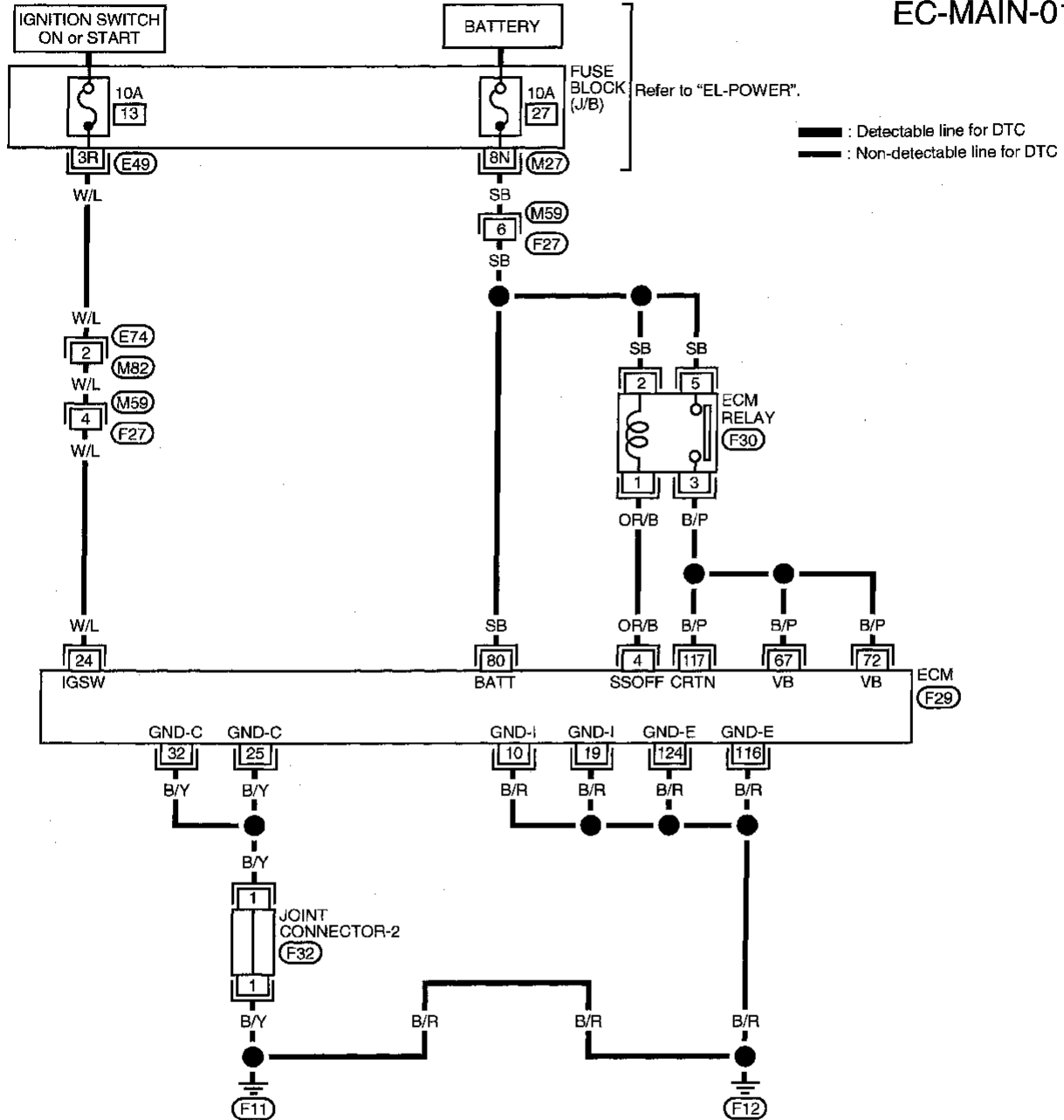

AEC752A

# TROUBLE DIAGNOSIS FOR POWER SUPPLY

Main Power Supply and Ground Circuit (Cont'd)

## ECM TERMINALS AND REFERENCE VALUE

NEEC0045

Specification data are reference values and are measured between each terminal and 32 (ECM ground).

TERMI- NAL NO.	WIRE COLOR	ITEM	CONDITION	DATA (DC Voltage)
4	OR/B	ECM relay (Self-shutoff)	[Engine is running] [Ignition switch "OFF"] • For a few seconds after turning ignition switch "OFF"	0 - 1.5V
			[Ignition switch "OFF"] • A few seconds passed after turning ignition switch "OFF"	BATTERY VOLTAGE (11 - 14V)
10	B/R	ECM ground	[Engine is running] • Idle speed	Engine ground
19	B/R	ECM ground	[Engine is running] • Idle speed	Engine ground
24	W/L	Ignition switch	[Ignition switch "OFF"]	0V
			[Ignition switch "ON"]	BATTERY VOLTAGE (11 - 14V)
25	B/Y	ECM ground	[Engine is running] • Idle speed	Engine ground
32	B/Y	ECM ground	[Engine is running] • Idle speed	Engine ground (Probe this terminal with (-) tester probe when measuring)
67	B/P	Power supply for ECM	[Ignition switch "ON"]	BATTERY VOLTAGE (11 - 14V)
72	B/P			
80	SB	Power supply (Back-up)	[Ignition switch "OFF"]	BATTERY VOLTAGE (11 - 14V)
116	B/R	ECM ground	[Engine is running] • Idle speed	Engine ground
117	B/P	Current return	[Engine is running] • Idle speed	BATTERY VOLTAGE (11 - 14V)
124	B/R	ECM ground	[Engine is running] • Idle speed	Engine ground

## DIAGNOSTIC PROCEDURE

NEEC0046

<b>1</b>	<b>INSPECTION START</b>	
Start engine. <b>Is engine running?</b>		
Yes or No		
Yes	▶	GO TO 6.
No	▶	GO TO 2.

# TROUBLE DIAGNOSIS FOR POWER SUPPLY

Main Power Supply and Ground Circuit (Cont'd)

<b>2</b>	<b>CHECK POWER SUPPLY-I</b>
<ol style="list-style-type: none"> <li>Turn ignition switch "OFF" and then "ON".</li> <li>Check voltage between ECM terminal 24 and ground with CONSULT or tester.</li> </ol>	
<p><b>Voltage: Battery voltage</b></p> <p><b>OK or NG</b></p>	
OK	▶ GO TO 4.
NG	▶ GO TO 3.

<b>3</b>	<b>DETECT MALFUNCTIONING PART</b>
<p>Check the following.</p> <ul style="list-style-type: none"> <li>Harness connectors E74, M82</li> <li>Harness connectors M59, F27</li> <li>Fuse block (J/B) connector E49</li> <li>10A fuse</li> <li>Harness for open or short between ECM and fuse</li> </ul>	
<p>▶ Repair harness or connectors.</p>	

<b>4</b>	<b>CHECK GROUND CIRCUIT-I</b>
<ol style="list-style-type: none"> <li>Turn ignition switch "OFF".</li> <li>Disconnect ECM harness connector.</li> <li>Check harness continuity between ECM terminals 10, 19, 25, 32, 116, 124 and engine ground.</li> </ol>	
<p><b>Continuity should exist.</b></p> <p>4. Also check harness for short to ground and short to power.</p> <p><b>OK or NG</b></p>	
OK	▶ GO TO 15.
NG	▶ GO TO 5.

<b>5</b>	<b>DETECT MALFUNCTIONING PART</b>
<p>Check the following.</p> <ul style="list-style-type: none"> <li>Joint connector-2</li> <li>Harness for open or short between ECM and engine ground</li> </ul>	
<p>▶ Repair open circuit or short to ground or short to power in harness or connectors.</p>	

<b>6</b>	<b>CHECK POWER SUPPLY-II</b>
<ol style="list-style-type: none"> <li>Stop engine.</li> <li>Check voltage between ECM terminal 80 and ground with CONSULT or tester.</li> </ol>	
<p><b>Voltage: Battery voltage</b></p> <p><b>OK or NG</b></p>	
OK	▶ GO TO 8.
NG	▶ GO TO 7.

<b>7</b>	<b>DETECT MALFUNCTIONING PART</b>
<p>Check the following.</p> <ul style="list-style-type: none"> <li>Harness connectors M59, F27</li> <li>Fuse block (J/B) connector M27</li> <li>10A fuse</li> <li>Harness for open or short between ECM and fuse</li> </ul>	
<p>▶ Repair harness or connectors.</p>	

# TROUBLE DIAGNOSIS FOR POWER SUPPLY

Main Power Supply and Ground Circuit (Cont'd)

<b>8</b>	<b>CHECK POWER SUPPLY-III</b>
<ol style="list-style-type: none"> <li>Turn ignition switch "ON" and then "OFF".</li> <li>Check voltage between ECM terminals 67, 72, 117 and ground with CONSULT or tester.</li> </ol>	
SEF679U	
<p><b>Voltage:</b> After turning ignition switch "OFF", battery voltage will exist for a few seconds, then drop to approximately 0V.</p>	
OK or NG	
OK	▶ GO TO 14.
NG (Battery voltage does not exist.)	▶ GO TO 9.
NG (Battery voltage exists for more than a few seconds.)	▶ GO TO 13.

<b>9</b>	<b>CHECK POWER SUPPLY-IV</b>
<ol style="list-style-type: none"> <li>Disconnect ECM relay.</li> </ol>	
<p><b>View from passenger side</b></p>	
AEC927A	
<ol style="list-style-type: none"> <li>Check voltage between terminals 2, 5 and ground with CONSULT or tester.</li> </ol>	
SEF625W	
<p><b>Voltage: Battery voltage</b></p>	
OK or NG	
OK	▶ GO TO 11.
NG	▶ GO TO 10.

<b>10</b>	<b>DETECT MALFUNCTIONING PART</b>
<p>Check the following.</p> <ul style="list-style-type: none"> <li>Harness for open or short between ECM relay and harness connector F27</li> </ul>	
▶	Repair open circuit or short to ground or short to power in harness or connectors.

GI  
MA  
EM  
LC  
EC  
FE  
CL  
MT  
AT  
TF  
PD  
FA  
RA  
BR  
ST  
RS  
BT  
HA  
EL  
IDX

# TROUBLE DIAGNOSIS FOR POWER SUPPLY

## Main Power Supply and Ground Circuit (Cont'd)

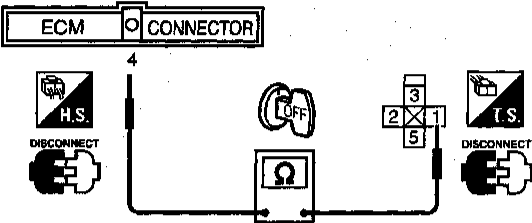
<b>11</b>	<b>CHECK OUTPUT SIGNAL CIRCUIT</b>
<ol style="list-style-type: none"> <li>1. Disconnect ECM harness connector.</li> <li>2. Check harness continuity between ECM terminal 4 and relay terminal 1.</li> </ol>	
	
SEF037W	
<p><b>Continuity should exist.</b></p> <ol style="list-style-type: none"> <li>3. Also check harness for short to ground and short to power.</li> </ol> <p><b>OK or NG</b></p>	
OK	▶ GO TO 12.
NG	▶ Repair open circuit or short to ground or short to power in harness or connectors.

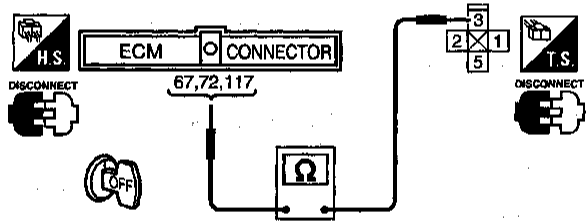
<b>12</b>	<b>CHECK HARNESS CONTINUITY BETWEEN ECM RELAY AND ECM</b>
<ol style="list-style-type: none"> <li>1. Check harness continuity between ECM terminals 67, 72, 117 and relay terminal 3.</li> </ol>	
	
SEF626W	
<p><b>Continuity should exist.</b></p> <ol style="list-style-type: none"> <li>2. Also check harness for short to ground and short to power.</li> </ol> <p><b>OK or NG</b></p>	
OK	▶ GO TO 13.
NG	▶ Repair open circuit or short to ground or short to power in harness or connectors.

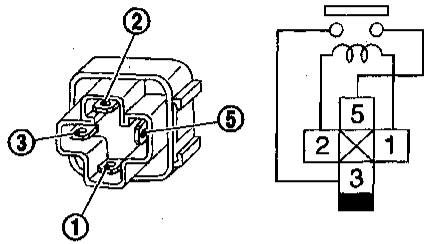
<b>13</b>	<b>CHECK ECM RELAY</b>
<ol style="list-style-type: none"> <li>1. Apply 12V direct current between relay terminals 1 and 2.</li> <li>2. Check continuity between relay terminals 3 and 5.</li> </ol>	
	
SEF039W	
<p><b>12V (1 - 2) applied: Continuity exists.</b>  <b>No voltage applied: No continuity</b></p> <p><b>OK or NG</b></p>	
OK	▶ GO TO 14.
NG	▶ Replace ECM relay.

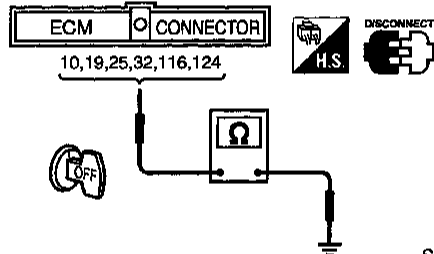
<b>14</b>	<b>CHECK GROUND CIRCUIT-II</b>
<ol style="list-style-type: none"> <li>1. Turn ignition switch "OFF".</li> <li>2. Disconnect ECM harness connector.</li> <li>3. Check harness continuity between ECM terminals 10, 19, 25, 32, 116, 124 and engine ground.</li> </ol>	
	
SEF675U	
<p><b>Continuity should exist.</b></p> <ol style="list-style-type: none"> <li>4. Also check harness for short to ground and short to power.</li> </ol> <p><b>OK or NG</b></p>	
OK	▶ GO TO 15.
NG	▶ GO TO 5.

<b>15</b>	<b>CHECK INTERMITTENT INCIDENT</b>
<p>Refer to "TROUBLE DIAGNOSIS FOR INTERMITTENT INCIDENT", EC-115.</p>	
<p>▶ <b>INSPECTION END</b></p>	

# DTC P0100 MASS AIR FLOW SENSOR (MAFS)

Component Description

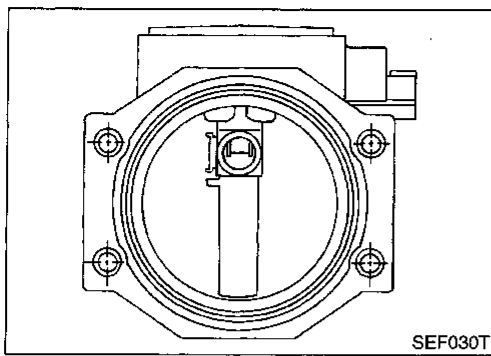

## Component Description

The mass air flow sensor is placed in the stream of intake air. It measures the intake flow rate by measuring a part of the entire intake flow. It consists of a hot wire that is supplied with electric current from the ECM. The temperature of the hot wire is controlled by the ECM a certain amount. The heat generated by the hot wire is reduced as the intake air flows around it. The more air, the greater the heat loss.

Therefore, the ECM must supply more electric current to maintain the temperature of the hot wire as air flow increases. The ECM detects the air flow by means of this current change.

## CONSULT Reference Value in Data Monitor Mode

Specification data are reference values.

MONITOR ITEM	CONDITION	SPECIFICATION
MAS AIR/FL SE	<ul style="list-style-type: none"> <li>Engine: After warming up</li> <li>Air conditioner switch: "OFF"</li> <li>Shift lever: "N"</li> <li>No-load</li> </ul> Idle	1.0 - 1.7V
	2,500 rpm	1.7 - 2.3V
CAL/LD VALUE	ditto Idle	18.5 - 26.0%
	2,500 rpm	18.0 - 21.0%
MASS AIRFLOW	ditto Idle	3.3 - 4.8 g·m/s
	2,500 rpm	12.0 - 14.9 g·m/s

## ECM Terminals and Reference Value

Specification data are reference values and are measured between each terminal and 32 (ECM ground).

TERMI-NAL NO.	WIRE COLOR	ITEM	CONDITION	DATA (DC Voltage)
54	R	Mass air flow sensor	[Engine is running] <ul style="list-style-type: none"> <li>Warm-up condition</li> <li>Idle speed</li> </ul>	1.0 - 1.7V
			[Engine is running] <ul style="list-style-type: none"> <li>Warm-up condition</li> <li>Engine speed is 2,500 rpm</li> </ul>	1.7 - 2.3V
55	G	Mass air flow sensor ground	[Engine is running] <ul style="list-style-type: none"> <li>Warm-up condition</li> <li>Idle speed</li> </ul>	Approximately 0V

## On Board Diagnosis Logic

DTC No.	Malfunction is detected when ...	Check Items (Possible Cause)
P0100 0102	A) An excessively high voltage from the sensor is sent to ECM when engine is not running.	<ul style="list-style-type: none"> <li>Harness or connectors (The sensor circuit is open or shorted.)</li> <li>Mass air flow sensor</li> </ul>
	C) A high voltage from the sensor is sent to ECM under light load driving condition.	
	B) An excessively low voltage from the sensor is sent to ECM when engine is running.*	<ul style="list-style-type: none"> <li>Harness or connectors (The sensor circuit is open or shorted.)</li> <li>Intake air leaks</li> <li>Mass air flow sensor</li> </ul>
	D) A low voltage from the sensor is sent to ECM under heavy load driving condition.	

\*: When this malfunction is detected, the ECM enters fail-safe mode and the MIL lights up.

## DTC P0100 MASS AIR FLOW SENSOR (MAFS)

On Board Diagnosis Logic (Cont'd)

Detected items	Engine operating condition in fail-safe mode
Mass air flow sensor circuit	Engine speed will not rise more than 2,400 rpm due to the fuel cut.

### DTC Confirmation Procedure

NEEC0051

Perform "PROCEDURE FOR MALFUNCTION A" first.

If the 1st trip DTC cannot be confirmed, perform "PROCEDURE FOR MALFUNCTION B".

If there is no problem on "PROCEDURE FOR MALFUNCTION B", perform "PROCEDURE FOR MALFUNCTION C".

If there is no problem on "PROCEDURE FOR MALFUNCTION C", perform "PROCEDURE FOR MALFUNCTION D".

#### NOTE:

If "DTC Confirmation Procedure" has been previously conducted, always turn ignition switch "OFF" and wait at least 5 seconds before conducting the next test.

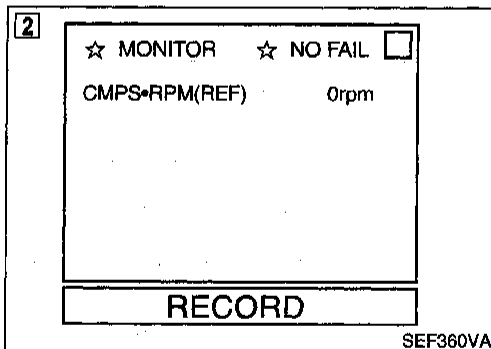

### PROCEDURE FOR MALFUNCTION A

NEEC0051901

#### ⓑ With CONSULT

- 1) Turn ignition switch "ON".
- 2) Select "DATA MONITOR" mode with CONSULT.
- 3) Wait at least 6 seconds.
- 4) If 1st trip DTC is detected, go to "Diagnostic Procedure", EC-127.

#### Ⓒ With GST

- 1) Turn ignition switch "ON", and wait at least 6 seconds.
- 2) Select "MODE 7" with GST.
- 3) If 1st trip DTC is detected, go to "Diagnostic Procedure", EC-127.

#### Ⓓ No Tools

- 1) Turn ignition switch "ON", and wait at least 6 seconds.
- 2) Turn ignition switch "OFF", wait at least 5 seconds and then turn "ON".
- 3) Perform "Diagnostic Test Mode II (Self-diagnostic results)" with ECM.
- 4) If 1st trip DTC is detected, go to "Diagnostic Procedure", EC-127.



# DTC P0100 MASS AIR FLOW SENSOR (MAFS)

DTC Confirmation Procedure (Cont'd)

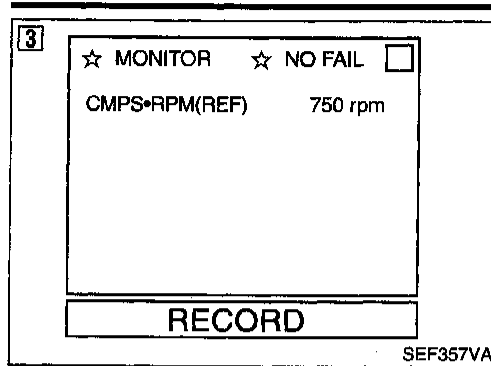

## PROCEDURE FOR MALFUNCTION B

NEEC0061S02

### With CONSULT

- 1) Turn ignition switch "ON".
- 2) Select "DATA MONITOR" mode with CONSULT.
- 3) Start engine and wait 5 seconds at most.
- 4) If 1st trip DTC is detected, go to "Diagnostic Procedure", EC-127.

### With GST

- 1) Start engine and wait 5 seconds at most.
- 2) Select "MODE 7" with GST.
- 3) If 1st trip DTC is detected, go to "Diagnostic Procedure", EC-127.

### No Tools

- 1) Start engine and wait 5 seconds at most.
- 2) Turn ignition switch "OFF", wait at least 5 seconds and then turn "ON".
- 3) Perform "Diagnostic Test Mode II (Self-diagnostic results)" with ECM.
- 4) If 1st trip DTC is detected, go to "Diagnostic Procedure", EC-127.

### NOTE:

If 1st trip DTC is confirmed after more than 5 seconds, there may be malfunction C.

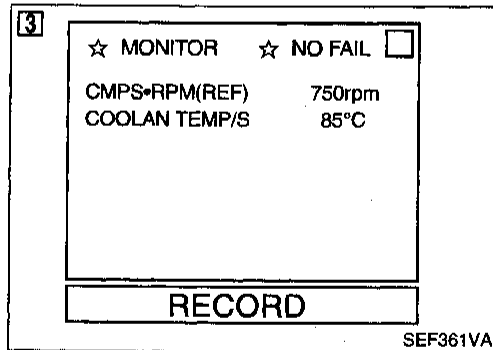

## PROCEDURE FOR MALFUNCTION C

NEEC0061S03

### NOTE:

If engine will not start or stops soon, wait at least 10 seconds with engine stopped (Ignition switch "ON") instead of running engine at idle speed.

### With CONSULT

- 1) Turn ignition switch "ON".
- 2) Select "DATA MONITOR" mode with CONSULT.
- 3) Start engine and warm it up to normal operating temperature.
- 4) Run engine for at least 10 seconds at idle speed.
- 5) If 1st trip DTC is detected, go to "Diagnostic Procedure", EC-127.

### With GST

- 1) Start engine and warm it up to normal operating temperature.
- 2) Run engine for at least 10 seconds at idle speed.
- 3) Select "MODE 7" with GST.
- 4) If 1st trip DTC is detected, go to "Diagnostic Procedure", EC-127.

### No Tools

- 1) Start engine and warm it up to normal operating temperature.
- 2) Run engine for at least 10 seconds at idle speed.

GI  
MA  
EM  
LC  
EC  
FE  
CL  
MT  
AT  
TF  
PD  
FA  
RA  
BR  
ST  
RS  
BT  
HA  
EL  
IDX

# DTC P0100 MASS AIR FLOW SENSOR (MAFS)

DTC Confirmation Procedure (Cont'd)

- 3) Turn ignition switch "OFF", wait at least 5 seconds and then turn "ON".
- 4) Perform "Diagnostic Test Mode II (Self-diagnostic results)" with ECM.
- 5) If 1st trip DTC is detected, go to "Diagnostic Procedure", EC-127.

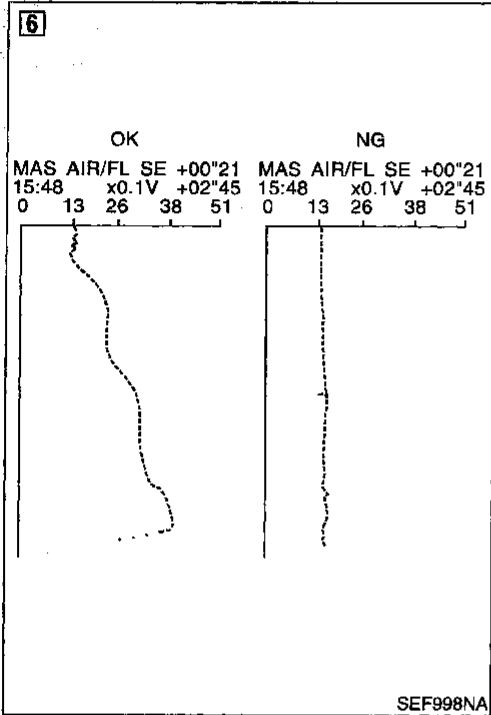

The monitor screen shows the following settings and values:

- ☆ MONITOR    ☆ NO FAIL
- CMPS-RPM(REF)    3000rpm
- VHCL SPEED SE    70km/h
- THRTL POS SEN    3.2V

**RECORD**

SEF362VA

## PROCEDURE FOR MALFUNCTION D

NEEC0051S04

### CAUTION:

Always drive vehicle at a safe speed.

#### With CONSULT

- 1) Turn ignition switch "ON".
- 2) Start engine and warm it up to normal operating temperature. **If engine cannot be started, go to "Diagnostic Procedure", EC-127.**
- 3) Select "DATA MONITOR" mode with CONSULT.
- 4) Check the voltage of MAS AIR/FL SE with "DATA MONITOR".
- 5) Increases engine speed to about 4,000 rpm.
- 6) Monitor the linear voltage rise in response to engine speed increases.  
If NG, go to "Diagnostic Procedure", EC-127.  
If OK, go to following step.
- 7) Maintain the following conditions for at least 10 consecutive seconds.

CMPS-RPM (REF)	More than 2,000 rpm
THRTL POS SEN	More than 3V
Selector lever	Suitable position
Driving location	Driving vehicle uphill (Increased engine load) will help maintain the driving conditions required for this test.

- 8) If 1st trip DTC is detected, go to "Diagnostic Procedure", EC-127.

# DTC P0100 MASS AIR FLOW SENSOR (MAFS)

Overall Function Check

CALC LOAD	20%
COOLANT TEMP	95°C
SHORT FT #1	2%
LONG FT #1	0%
SHORT FT #2	4%
LONG FT #2	0%
ENGINE SPD	2637RPM
VEHICLE SPD	0MPH
IGN ADVANCE	41.0°
INTAKE AIR	41°C
<b>MAF</b>	<b>14.1gm/sec</b>
THROTTLE POS	3%

SEF534P

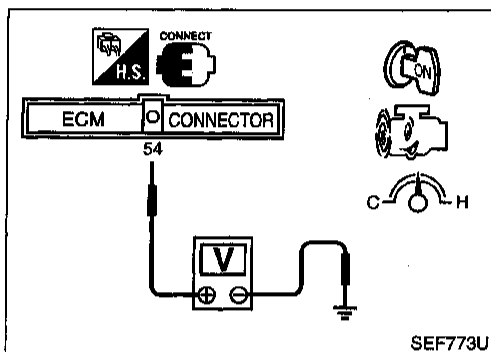

## Overall Function Check

### PROCEDURE FOR MALFUNCTION D

Use this procedure to check the overall function of the mass air flow sensor circuit. During this check, a 1st trip DTC might not be confirmed.

#### With GST

- 1) Start engine and warm it up to normal operating temperature.
- 2) Select "MODE 1" with GST.
- 3) Check the mass air flow sensor signal with "MODE 1".
- 4) Check for linear mass air flow sensor signal value rise in response to increases to about 4,000 rpm in engine speed.
- 5) If NG, go to "Diagnostic Procedure", EC-127.

#### No Tools

- 1) Start engine and warm it up to normal operating temperature.
- 2) Check the voltage between ECM terminal 54 (Mass air flow sensor signal) and ground.
- 3) Check for linear voltage rise in response to increases to about 4,000 rpm in engine speed.
- 4) If NG, go to "Diagnostic Procedure", EC-127.

NEEC0539

NEEC0539S01

GI

MA

EM

LC

EC

FE

CL

MT

AT

TF

PD

FA

RA

BR

ST

RS

BT

HA

EL

IDX

# DTC P0100 MASS AIR FLOW SENSOR (MAFS)

Wiring Diagram

## Wiring Diagram

NEEC0052

EC-MAFS-01

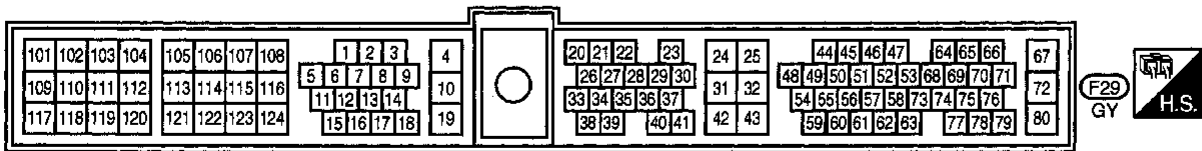
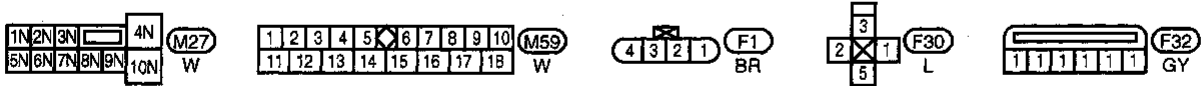
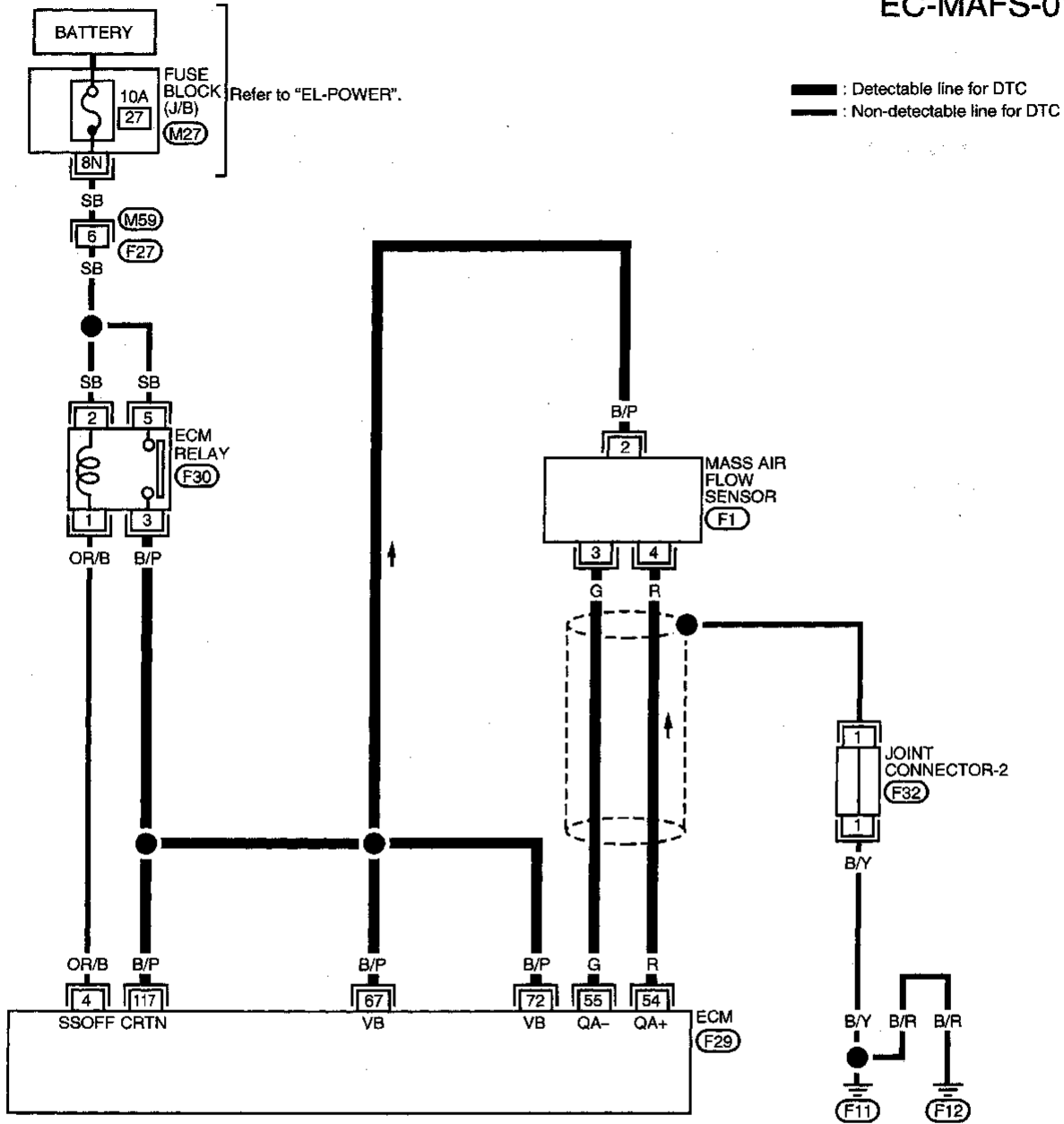

AEC753A

## Diagnostic Procedure

NEEC0053

<b>1</b>	<b>INSPECTION START</b>						
Which malfunction (A, B, C or D) is duplicated?							
<table border="1"> <thead> <tr> <th>MALFUNCTION</th> <th>Type</th> </tr> </thead> <tbody> <tr> <td>A and/or C</td> <td>I</td> </tr> <tr> <td>B and/or D</td> <td>II</td> </tr> </tbody> </table>		MALFUNCTION	Type	A and/or C	I	B and/or D	II
MALFUNCTION	Type						
A and/or C	I						
B and/or D	II						
MTBL0063							
<b>Type I or Type II</b>							
Type I	▶ GO TO 3.						
Type II	▶ GO TO 2.						

<b>2</b>	<b>CHECK INTAKE SYSTEM</b>
Check the following for connection.	
<ul style="list-style-type: none"> <li>• Air duct</li> <li>• Vacuum hoses</li> <li>• Intake air passage between air duct to intake manifold collector</li> </ul>	
<b>OK or NG</b>	
OK	▶ GO TO 3.
NG	▶ Reconnect the parts.

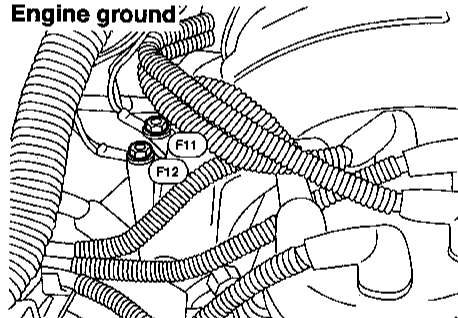
<b>3</b>	<b>RETIGHTEN GROUND SCREWS</b>
<ol style="list-style-type: none"> <li>1. Turn ignition switch "OFF".</li> <li>2. Loosen and retighten engine ground screws.</li> </ol>	
 <p style="text-align: right;">AEC640A</p>	
▶ GO TO 4.	

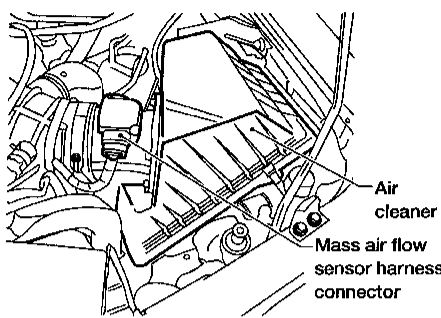
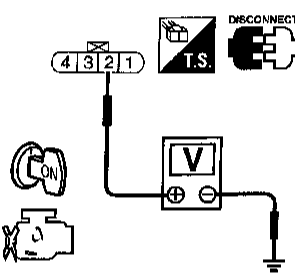
<b>4</b>	<b>CHECK POWER SUPPLY</b>
1. Disconnect mass air flow sensor harness connector.	
 <p style="text-align: right;">AEC641A</p>	
<ol style="list-style-type: none"> <li>2. Turn ignition switch "ON".</li> <li>3. Check voltage between terminal 2 and ground with CONSULT or tester.</li> </ol>	
 <p style="text-align: center;">Voltage: Battery voltage</p> <p style="text-align: center;"><b>OK or NG</b></p> <p style="text-align: right;">SEF627W</p>	
OK	▶ GO TO 6.
NG	▶ GO TO 5.

<b>5</b>	<b>DETECT MALFUNCTIONING PART</b>
Check the following.	
<ul style="list-style-type: none"> <li>• Harness for open or short between ECM relay and mass air flow sensor</li> <li>• Harness for open or short between mass air flow sensor and ECM</li> </ul>	
▶ Repair harness or connectors.	

GI  
MA  
EM  
LC  
EC  
FE  
CL  
MT  
AT  
TF  
PD  
FA  
RA  
BR  
ST  
RS  
BT  
HA  
EL  
IDX

## DTC P0100 MASS AIR FLOW SENSOR (MAFS)

Diagnostic Procedure (Cont'd)

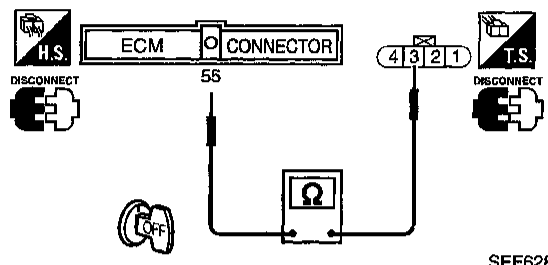
<b>6</b>	<b>CHECK GROUND CIRCUIT</b>
<ol style="list-style-type: none"> <li>1. Turn ignition switch "OFF".</li> <li>2. Disconnect ECM harness connector.</li> <li>3. Check harness continuity between terminal 3 and ECM terminal 55.</li> </ol>	
	
<p><b>Continuity should exist.</b></p> <ol style="list-style-type: none"> <li>4. Also check harness for short to ground and short to power.</li> </ol>	
<b>OK or NG</b>	
OK	▶ GO TO 7.
NG	▶ Repair open circuit or short to ground or short to power in harness or connectors.

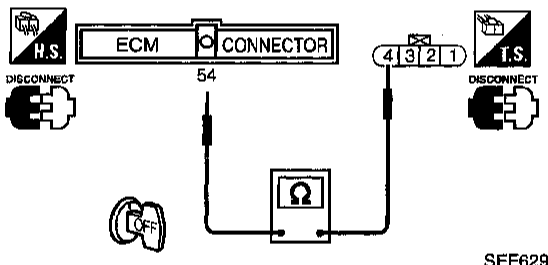
<b>7</b>	<b>CHECK INPUT SIGNAL CIRCUIT</b>
<ol style="list-style-type: none"> <li>1. Check harness continuity between terminal 4 and ECM terminal 54.</li> </ol>	
	
<p><b>Continuity should exist.</b></p> <ol style="list-style-type: none"> <li>2. Also check harness for short to ground and short to power.</li> </ol>	
<b>OK or NG</b>	
OK	▶ GO TO 8.
NG	▶ Repair open circuit or short to ground or short to power in harness or connectors.

<b>8</b>	<b>CHECK MASS AIR FLOW SENSOR</b>
Refer to "Component Inspection", EC-129.	
<b>OK or NG</b>	
OK	▶ GO TO 9.
NG	▶ Replace mass air flow sensor.

<b>9</b>	<b>CHECK SHIELD CIRCUIT</b>
<ol style="list-style-type: none"> <li>1. Turn ignition switch "OFF".</li> <li>2. Disconnect joint connector-2.</li> <li>3. Check the following. <ul style="list-style-type: none"> <li>• Continuity between joint connector terminal and ground</li> <li>• Joint connector</li> </ul>                     (Refer to "HARNESS LAYOUT" in EL section.)                 </li> <li>4. Also check harness for short to ground and short to power.</li> <li>5. Then reconnect joint connector-2.</li> </ol>	
<b>Continuity should exist.</b>	
<b>OK or NG</b>	
OK	▶ GO TO 10.
NG	▶ Repair open circuit or short to ground or short to power in harness or connectors.

<b>10</b>	<b>CHECK INTERMITTENT INCIDENT</b>
Refer to "TROUBLE DIAGNOSIS FOR INTERMITTENT INCIDENT", EC-115.	
▶ <b>INSPECTION END</b>	

# DTC P0100 MASS AIR FLOW SENSOR (MAFS)

Component Inspection

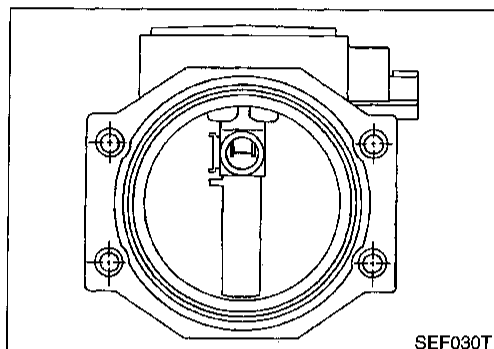
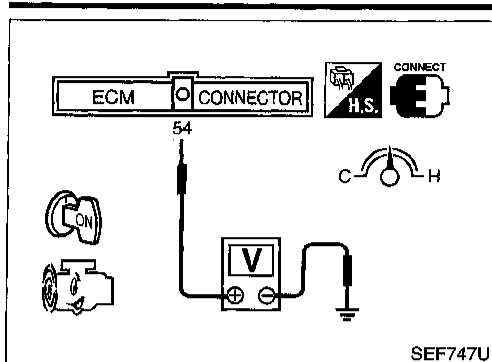

## Component Inspection MASS AIR FLOW SENSOR

NEEC0054

NEEC0054S01

1. Reconnect harness connectors disconnected.
2. Start engine and warm it up to normal operating temperature.
3. Check voltage between ECM terminal 54 (Mass air flow sensor signal) and ground.

Conditions	Voltage V
Ignition switch "ON" (Engine stopped.)	Less than 1.0
Idle (Engine is warmed-up to normal operating temperature.)	1.0 - 1.7
2,500 rpm (Engine is warmed-up to normal operating temperature.)	1.7 - 2.3
Idle to about 4,000 rpm*	1.0 - 1.7 to Approx. 4.0

\*: Check for linear voltage rise in response to increases to about 4,000 rpm in engine speed.

4. If the voltage is out of specification, disconnect mass air flow sensor harness connector and connect it again. Then repeat above check.
5. If NG, remove mass air flow sensor from air duct. Check hot wire for damage or dust.

GI  
MA  
EM  
LC  
EC  
FE  
CL  
MT  
AT  
TF  
PD  
FA  
RA  
BR  
ST  
RS  
BT  
HA  
EL  
IDX

# DTC P0105 ABSOLUTE PRESSURE SENSOR

## Component Description

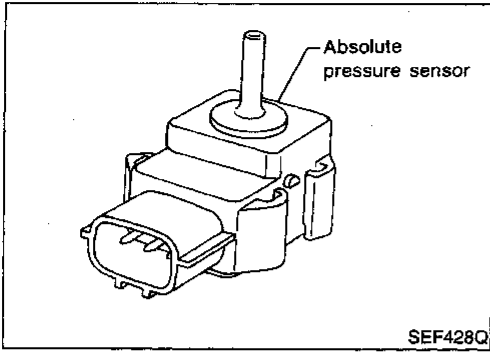

## Component Description

The absolute pressure sensor is connected to the MAP/BARO switch solenoid valve by a hose. The sensor detects ambient barometric pressure and intake manifold absolute pressure and sends the voltage signal to the ECM. As the pressure increases, the voltage rises.

NEEC0055

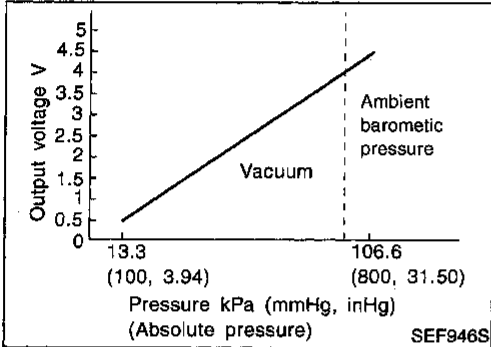

## On Board Diagnosis Logic

NEEC0056

DTC No.	Malfunction is detected when ...		Check Items (Possible Cause)
P0105 0803	A)	An excessively low or high voltage from the sensor is sent to ECM.	<ul style="list-style-type: none"> <li>• Harness or connectors (Absolute pressure sensor circuit is open or shorted.)</li> <li>• Absolute pressure sensor</li> </ul>
	B)	A high voltage from the sensor is sent to ECM under light load driving conditions.	<ul style="list-style-type: none"> <li>• Hoses (Hoses between the intake manifold and absolute pressure sensor are disconnected or clogged.)</li> <li>• Intake air leaks</li> <li>• MAP/BARO switch solenoid valve</li> <li>• Absolute pressure sensor</li> </ul>
	C)	A low voltage from the sensor is sent to ECM under heavy load driving conditions.	<ul style="list-style-type: none"> <li>• Absolute pressure sensor</li> </ul>

## DTC Confirmation Procedure

NEEC0057

Perform "PROCEDURE FOR MALFUNCTION A" first. If the 1st trip DTC cannot be confirmed, perform "PROCEDURE FOR MALFUNCTION B".

If the 1st trip DTC is not confirmed on "PROCEDURE FOR MALFUNCTION B", perform "PROCEDURE FOR MALFUNCTION C".

### NOTE:

If "DTC Confirmation Procedure" has been previously conducted, always turn ignition switch "OFF" and wait at least 5 seconds before conducting the next test.



# DTC P0105 ABSOLUTE PRESSURE SENSOR

DTC Confirmation Procedure (Cont'd)

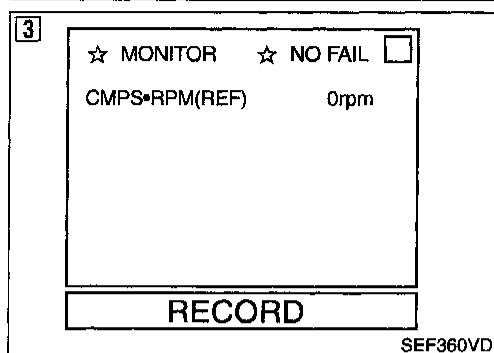

## PROCEDURE FOR MALFUNCTION A

NEEC0057901

### With CONSULT

- 1) Turn ignition switch "ON".
- 2) Select "DATA MONITOR" mode with CONSULT.
- 3) Wait at least 6 seconds.
- 4) If 1st trip DTC is detected, go to "Diagnostic Procedure", EC-134.

### With GST

- 1) Turn ignition switch "ON" and wait at least 6 seconds.
- 2) Select "MODE 7" with GST.
- 3) If 1st trip DTC is detected, go to "Diagnostic Procedure", EC-134.

### No Tools

- 1) Turn ignition switch "ON" and wait at least 6 seconds.
- 2) Turn ignition switch "OFF", wait at least 5 seconds and then turn "ON".
- 3) Perform "Diagnostic Test Mode II (Self-diagnostic results)" with ECM.
- 4) If 1st trip DTC is detected, go to "Diagnostic Procedure", EC-134.

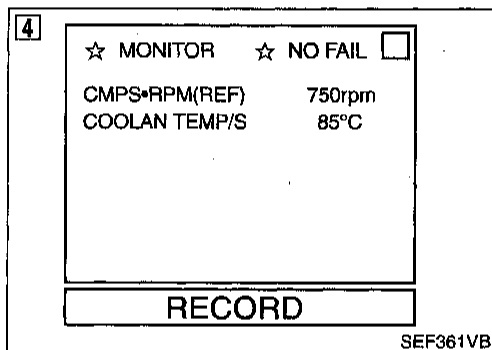

## PROCEDURE FOR MALFUNCTION B

NEEC0057902

### With CONSULT

- 1) Start engine and warm it up to normal operating temperature.
- 2) Turn ignition switch "OFF" and wait at least 5 seconds.
- 3) Turn ignition switch "ON" and select "DATA MONITOR" mode with CONSULT.
- 4) Start engine and let it idle.
- 5) Wait at least 15 seconds.
- 6) If 1st trip DTC is detected, go to "Diagnostic Procedure", EC-134.

### With GST

- 1) Start engine and warm it up to normal operating temperature.
- 2) Turn ignition switch "OFF" and wait at least 5 seconds.
- 3) Start engine.
- 4) Let engine idle and wait at least 15 seconds.
- 5) Select "MODE 7" with GST.
- 6) If 1st trip DTC is detected, go to "Diagnostic Procedure", EC-134.

### No Tools

- 1) Start engine and warm it up to normal operating temperature.
- 2) Turn ignition switch "OFF" and wait at least 5 seconds.
- 3) Start engine.
- 4) Let engine idle and wait at least 15 seconds.
- 5) Turn ignition switch "OFF", wait at least 5 seconds and then turn "ON".
- 6) Perform "Diagnostic Test Mode II (Self-diagnostic results)" with ECM.
- 7) If 1st trip DTC is detected, go to "Diagnostic Procedure", EC-134.

# DTC P0105 ABSOLUTE PRESSURE SENSOR

DTC Confirmation Procedure (Cont'd)

7

☆ MONITOR
☆ NO FAIL

CMPS-RPM(REF)	4000rpm
VHCL SPEED SE	70km/h
B/FUEL SCHDL	4.8msec
ABSOL PRES/SE	4.4V

**RECORD**

SEF127VA

ENGINE SPD	.....	0RPM
COOLANT TEMP	.....	69°C
VEHICLE SPD	.....	0MPH
IGN ADVANCE	.....	3.0°
CALC LOAD	.....	0.0%
MAP	.....	101kPa
MAF	.....	0.25gm/s
THROTTLE POS	.....	0.0%
INTAKE AIR	.....	27°C
FUEL SYS #1	.....	OL
FUEL SYS #2	.....	UNUSED
SHORT FT #1	.....	0.0%
LONG FT #1	.....	0.0%
O2S B1 S1	.....	0.000V
O2FT B1 S1	.....	0.0%
O2S B1 S2	.....	0.000V

SEF518R

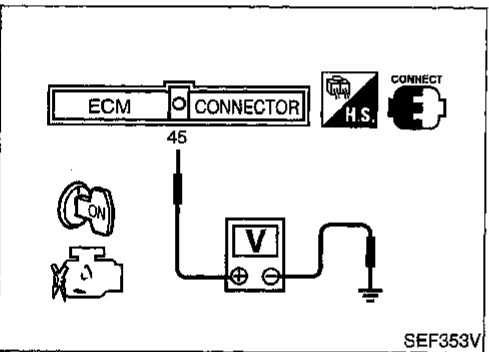

## PROCEDURE FOR MALFUNCTION C

NEEC0057S03

### CAUTION:

**Always drive vehicle at a safe speed.**

#### ⓑ With CONSULT

- 1) Turn ignition switch "ON".
- 2) Select "DATA MONITOR" mode with CONSULT.  
**The voltage of "ABSOL PRES/SE" should be more than 1.74 [V].**  
**If the check result is NG, go to "Diagnostic Procedure", EC-134.**  
**If the check result is OK, go to following step.**
- 3) Start engine and warm it up to normal operating temperature.
- 4) Turn ignition switch "OFF" and wait at least 5 seconds.
- 5) Start engine and let it idle for at least 13 seconds.
- 6) Select "DATA MONITOR" mode with CONSULT.
- 7) Drive the vehicle at least 3 consecutive seconds under the following conditions,

CMPS-RPM (REF)	3,000 - 4,800 rpm
B/FUEL SCHDL	More than 4.6 msec
Selector lever	Suitable position
Driving location	Driving vehicle uphill (Increased engine load) will help maintain the driving conditions required for this test.

- 8) If 1st trip DTC is detected, go to "Diagnostic Procedure", EC-134.

## Overall Function Check

NEEC0640

### PROCEDURE FOR MALFUNCTION C

NEEC0540S01

Use this procedure to check the overall function of the absolute pressure sensor circuit. During this check, a 1st trip DTC might not be confirmed.

#### ⓑ With GST

- 1) Turn ignition switch "ON".
- 2) Select absolute pressure sensor signal in "MODE 1" with GST.
- 3) Make sure that the signal is more than 46 kPa (0.47 kg/cm<sup>2</sup>, 6.7 psi).
- 4) If NG, go to "Diagnostic Procedure", EC-134.

#### ⓐ No Tools

- 1) Turn ignition switch "ON".
- 2) Make sure that the voltage between ECM terminal 45 (Absolute pressure sensor signal) and ground is more than 1.74 [V].
- 3) If NG, go to "Diagnostic Procedure", EC-134.

# DTC P0105 ABSOLUTE PRESSURE SENSOR

Wiring Diagram

## Wiring Diagram

NEEC0058

### EC-AP/SEN-01

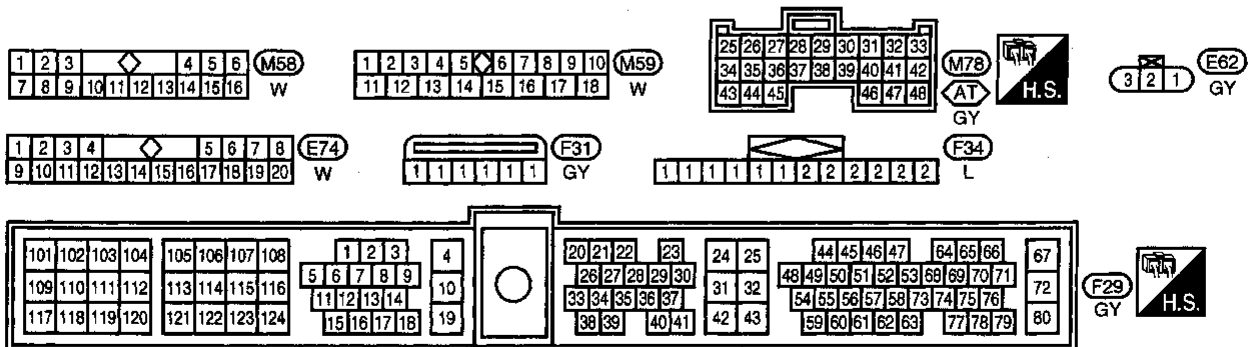
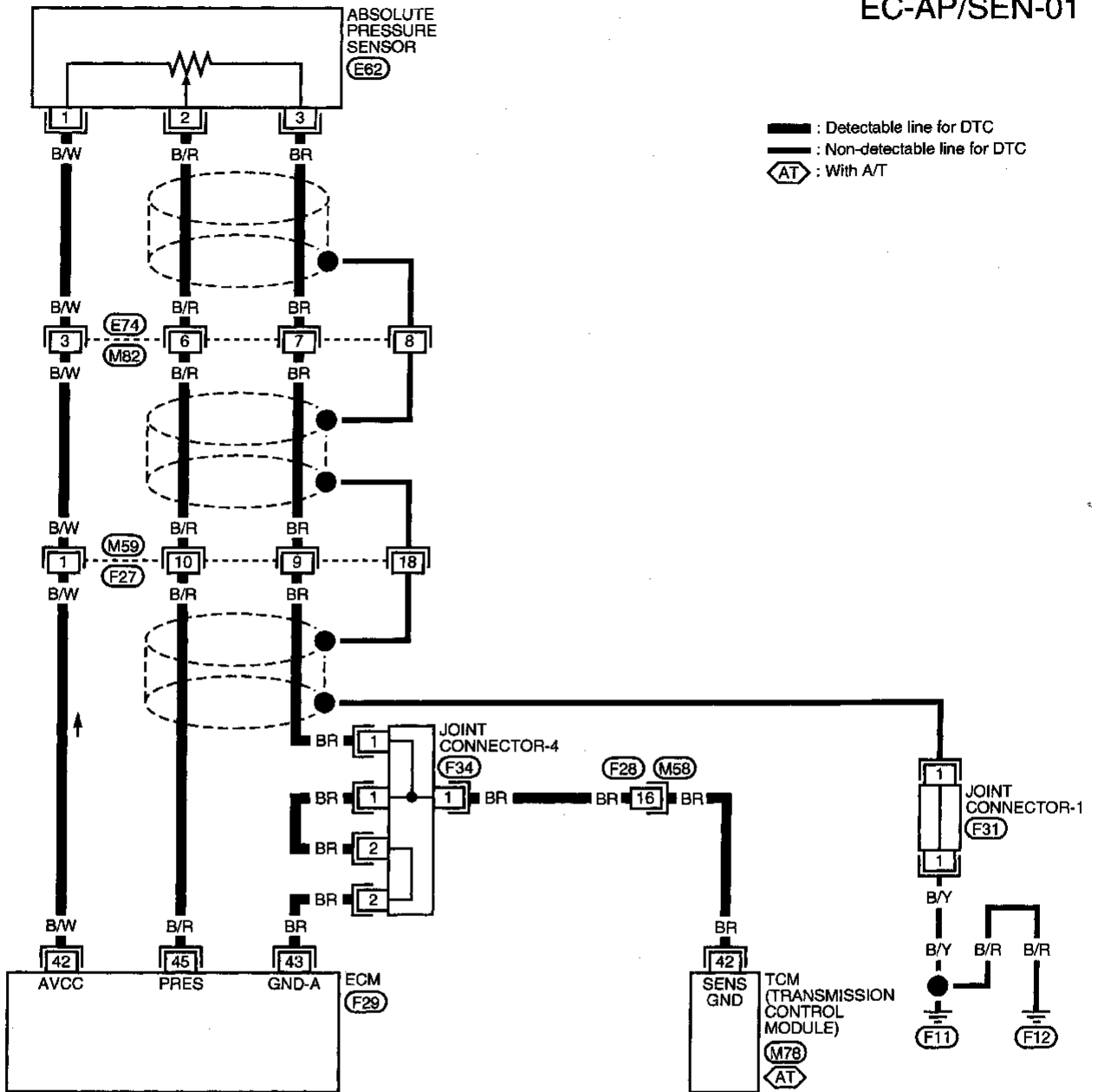

AEC754A

# DTC P0105 ABSOLUTE PRESSURE SENSOR

Diagnostic Procedure

## Diagnostic Procedure

If the trouble is duplicated after "PROCEDURE FOR MALFUNCTION A or C", perform "PROCEDURE A" below. If the trouble is duplicated after "PROCEDURE FOR MALFUNCTION B", perform "PROCEDURE B", EC-136.

NEEC0059

### PROCEDURE A

NEEC0059S01

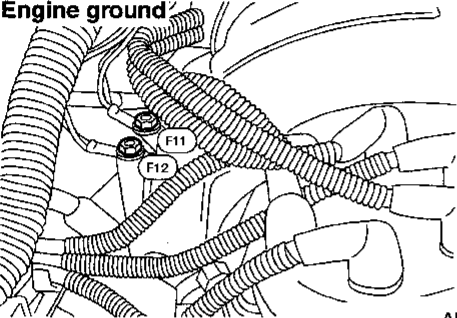
<b>1</b>	<b>RETIGHTEN GROUND SCREWS</b>
<ol style="list-style-type: none"> <li>Turn ignition switch "OFF".</li> <li>Loosen and retighten engine ground screws.</li> </ol>	
<p style="text-align: center;"><b>Engine ground</b></p>  <p style="text-align: right;">AEC640A</p>	
▶ GO TO 2.	

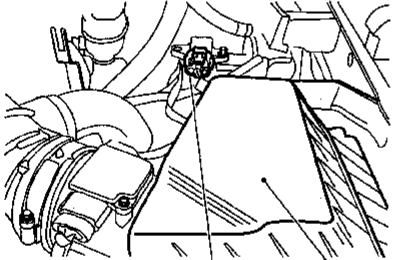
<b>2</b>	<b>CHECK CONNECTOR</b>
<ol style="list-style-type: none"> <li>Disconnect absolute pressure sensor harness connector.</li> </ol>	
 <p style="text-align: center;">Absolute pressure sensor — Air cleaner</p> <p style="text-align: right;">AEC642A</p>	
<ol style="list-style-type: none"> <li>Check sensor harness connector for water. <b>Water should not exist.</b></li> </ol> <p style="text-align: center;"><b>OK or NG</b></p>	
OK	▶ GO TO 3.
NG	▶ Repair or replace harness connector.

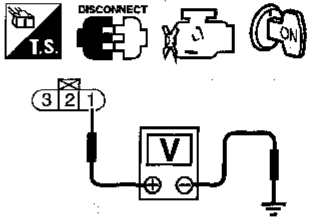
<b>3</b>	<b>CHECK POWER SUPPLY</b>
<ol style="list-style-type: none"> <li>Turn ignition switch "ON".</li> <li>Check voltage between terminal 1 and ground with CONSULT or tester.</li> </ol>	
 <p style="text-align: center;"><b>Voltage: Approximately 5V</b></p> <p style="text-align: center;"><b>OK or NG</b></p> <p style="text-align: right;">SEF200W</p>	
OK	▶ GO TO 5.
NG	▶ GO TO 4.

<b>4</b>	<b>DETECT MALFUNCTIONING PART</b>
<p>Check the following.</p> <ul style="list-style-type: none"> <li>Harness connectors E74, M82</li> <li>Harness connectors M59, F27</li> <li>Harness for open or short between ECM and absolute pressure sensor</li> </ul>	
▶ Repair harness or connectors.	

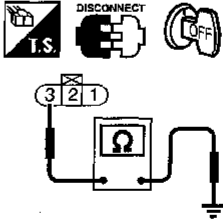
<b>5</b>	<b>CHECK GROUND CIRCUIT</b>
<ol style="list-style-type: none"> <li>Turn ignition switch "OFF".</li> <li>Check harness continuity between terminal 3 and engine ground.</li> </ol>	
 <p style="text-align: center;"><b>Continuity should exist.</b></p> <p style="text-align: center;"><b>OK or NG</b></p> <p style="text-align: right;">SEF201W</p>	
<ol style="list-style-type: none"> <li>Also check harness for short to ground and short to power.</li> </ol>	
OK	▶ GO TO 7.
NG	▶ GO TO 6.

# DTC P0105 ABSOLUTE PRESSURE SENSOR

Diagnostic Procedure (Cont'd)

<b>6</b>	<b>DETECT MALFUNCTIONING PART</b>
<p>Check the following.</p> <ul style="list-style-type: none"> <li>• Harness connectors E74, M82</li> <li>• Harness connectors M59, F27</li> <li>• Harness connectors F28, M58</li> <li>• Joint connector-4</li> <li>• Harness for open or short between ECM and absolute pressure sensor</li> <li>• Harness for open or short between TCM (Transmission Control Module) and absolute pressure sensor</li> </ul>	
▶	Repair open circuit or short to ground or short to power in harness or connectors.

<b>7</b>	<b>CHECK INPUT SIGNAL CIRCUIT</b>
<ol style="list-style-type: none"> <li>1. Disconnect ECM harness connector.</li> <li>2. Check harness continuity between ECM terminal 45 and terminal 2.</li> </ol>	
<p>Continuity should exist.</p> <p>3. Also check harness for short to ground and short to power.</p> <p style="text-align: center;"><b>OK or NG</b></p>	
OK	▶ GO TO 9.
NG	▶ GO TO 8.

<b>8</b>	<b>DETECT MALFUNCTIONING PART</b>
<p>Check the following.</p> <ul style="list-style-type: none"> <li>• Harness connectors E74, M82</li> <li>• Harness connectors M59, F27</li> <li>• Harness for open or short between ECM and absolute pressure sensor</li> </ul>	
▶	Repair open circuit or short to ground or short to power in harness or connectors.

<b>9</b>	<b>CHECK ABSOLUTE PRESSURE SENSOR</b>
Refer to "Component Inspection", EC-138.	
<b>OK or NG</b>	
OK	▶ GO TO 10.
NG	▶ Replace absolute pressure sensor.

<b>10</b>	<b>CHECK SHIELD CIRCUIT</b>
<ol style="list-style-type: none"> <li>1. Turn ignition switch "OFF".</li> <li>2. Disconnect joint connector-1.</li> <li>3. Check the following. <ul style="list-style-type: none"> <li>• Continuity between joint connector terminal and ground</li> <li>• Joint connector</li> </ul>                     (Refer to "HARNESS LAYOUT" in EL section.)                     <p style="text-align: center;"><b>Continuity should exist.</b></p> </li> <li>4. Also check harness for short to ground and short to power.</li> <li>5. Then reconnect joint connector-1.</li> </ol>	
<b>OK or NG</b>	
OK	▶ GO TO 11.
NG	▶ Repair open circuit or short to ground or short to power in harness or connectors.

<b>11</b>	<b>CHECK INTERMITTENT INCIDENT</b>
Refer to "TROUBLE DIAGNOSIS FOR INTERMITTENT INCIDENT", EC-115.	
▶	<b>INSPECTION END</b>

CI  
MA  
EM  
LC  
EC  
FE  
CL  
MT  
AT  
TF  
PD  
FA  
RA  
BR  
ST  
RS  
BT  
HA  
EL  
IDX

# DTC P0105 ABSOLUTE PRESSURE SENSOR

Diagnostic Procedure (Cont'd)

## PROCEDURE B

-NEEC0059602

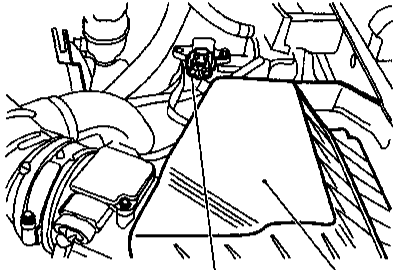
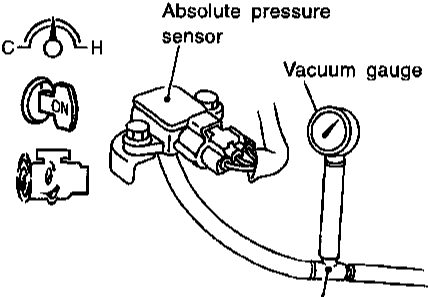
<b>1</b>	<b>INSPECTION START</b>
<ol style="list-style-type: none"> <li>1. Start engine and warm it up to normal operating temperature.</li> <li>2. Turn ignition switch "OFF".</li> <li>3. Attach the vacuum gauge between the absolute pressure sensor and the rubber tube connected to the MAP/BARO switch solenoid valve.</li> </ol>	
 <p>Absolute pressure sensor    Air cleaner</p> <p>AEC642A</p>	
 <p>Absolute pressure sensor    Vacuum gauge</p> <p>3-way connector</p> <p>SEF385U</p>	
Models with CONSULT	▶ GO TO 2.
Models without CONSULT	▶ GO TO 3.

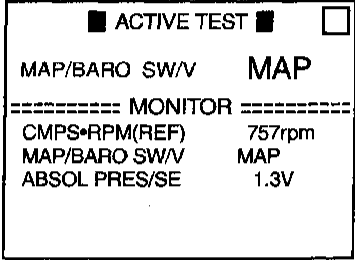
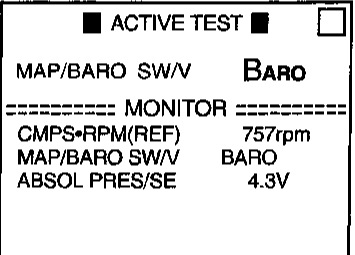
<b>2</b>	<b>CHECK VACUUM SOURCE TO ABSOLUTE PRESSURE SENSOR</b>						
<p><b>(With CONSULT)</b></p> <ol style="list-style-type: none"> <li>1. Start engine and let it idle.</li> <li>2. Select "MAP/BARO SW/V" in "ACTIVE TEST" mode with CONSULT.</li> <li>3. Touch "MAP" and "BARO" alternately and check for vacuum.</li> </ol>							
 <p>ACTIVE TEST</p> <p>MAP/BARO SW/V    MAP</p> <p>===== MONITOR =====</p> <p>CMPS•RPM(REF)    757rpm</p> <p>MAP/BARO SW/V    MAP</p> <p>ABSOL PRES/SE    1.3V</p> <p>BARO    MAP</p> <p>SEF396V</p>							
 <p>ACTIVE TEST</p> <p>MAP/BARO SW/V    BARO</p> <p>===== MONITOR =====</p> <p>CMPS•RPM(REF)    757rpm</p> <p>MAP/BARO SW/V    BARO</p> <p>ABSOL PRES/SE    4.3V</p> <p>BARO    MAP</p> <p>SEF397V</p>							
<table border="1" style="width: 100%;"> <tr> <td>MAP/BARO SW/V</td> <td>Vacuum</td> </tr> <tr> <td>BARO</td> <td>Should not exist</td> </tr> <tr> <td>MAP</td> <td>Should exist</td> </tr> </table> <p style="text-align: right;">MTBL0079</p>		MAP/BARO SW/V	Vacuum	BARO	Should not exist	MAP	Should exist
MAP/BARO SW/V	Vacuum						
BARO	Should not exist						
MAP	Should exist						
<b>OK or NG</b>							
OK	▶ GO TO 8.						
NG	▶ GO TO 4.						

<b>3</b>	<b>CHECK VACUUM SOURCE TO ABSOLUTE PRESSURE SENSOR</b>						
<p><b>(Without CONSULT)</b></p> <ol style="list-style-type: none"> <li>1. Start engine and let it idle.</li> <li>2. Check for vacuum under the following condition.</li> </ol>							
<table border="1" style="width: 100%;"> <thead> <tr> <th>Condition</th> <th>Vacuum</th> </tr> </thead> <tbody> <tr> <td>For 5 seconds after starting engine</td> <td>Should not exist</td> </tr> <tr> <td>More than 5 seconds after starting engine</td> <td>Should exist</td> </tr> </tbody> </table> <p style="text-align: right;">MTBL0080</p>		Condition	Vacuum	For 5 seconds after starting engine	Should not exist	More than 5 seconds after starting engine	Should exist
Condition	Vacuum						
For 5 seconds after starting engine	Should not exist						
More than 5 seconds after starting engine	Should exist						
<b>OK or NG</b>							
OK	▶ GO TO 8.						
NG	▶ GO TO 4.						

# DTC P0105 ABSOLUTE PRESSURE SENSOR

Diagnostic Procedure (Cont'd)

<b>4</b>	<b>CHECK VACUUM HOSE</b>
1. Turn ignition switch "OFF". 2. Check vacuum hose for clogging, cracks, disconnection or improper connection.	
<p>Split</p> <p>Clogging</p> <p>Improper connection</p> <p>SEF109L</p>	
<b>OK or NG</b>	
OK	▶ GO TO 5.
NG	▶ Clean, repair or replace the hose.

<b>5</b>	<b>CHECK VACUUM PORT</b>
Check vacuum port for clogging.	
<p>Intake manifold</p> <p>SEF368U</p>	
<b>OK or NG</b>	
OK	▶ GO TO 6.
NG	▶ Clean or repair the vacuum port.

<b>6</b>	<b>CHECK MAP/BARO SWITCH SOLENOID VALVE</b>
Refer to "Component Inspection", EC-363.	
<b>OK or NG</b>	
OK	▶ GO TO 7.
NG	▶ Replace MAP/BARO switch solenoid valve.

<b>7</b>	<b>CHECK INTAKE SYSTEM</b>
Check intake system for air leaks.	
<b>OK or NG</b>	
OK	▶ GO TO 11.
NG	▶ Repair it.

<b>8</b>	<b>CHECK HOSE BETWEEN ABSOLUTE PRESSURE SENSOR AND MAP/BARO SWITCH SOLENOID VALVE</b>
1. Turn ignition switch "OFF". 2. Check hose for clogging, cracks, disconnection or improper connection.	
<p>Split</p> <p>Clogging</p> <p>Improper connection</p> <p>SEF109L</p>	
<b>OK or NG</b>	
OK	▶ GO TO 9.
NG	▶ Repair or reconnect hose.

<b>9</b>	<b>CHECK HARNESS CONNECTOR</b>
1. Disconnect absolute pressure sensor harness connector. 2. Check sensor harness connector for water. <b>Water should not exist.</b>	
<b>OK or NG</b>	
OK	▶ GO TO 10.
NG	▶ Repair or replace harness connector.

<b>10</b>	<b>CHECK ABSOLUTE PRESSURE SENSOR</b>
Refer to "Component Inspection", EC-138.	
<b>OK or NG</b>	
OK	▶ GO TO 11.
NG	▶ Replace absolute pressure sensor.

<b>11</b>	<b>CHECK INTERMITTENT INCIDENT</b>
Refer to "TROUBLE DIAGNOSIS FOR INTERMITTENT INCIDENT", EC-115.	
▶ <b>INSPECTION END</b>	

GI  
MA  
EM  
LC  
EC  
FE  
CL  
MT  
AT  
TF  
PD  
FA  
RA  
BR  
ST  
RS  
BT  
HA  
EL  
IDX

# DTC P0105 ABSOLUTE PRESSURE SENSOR

## Component Inspection

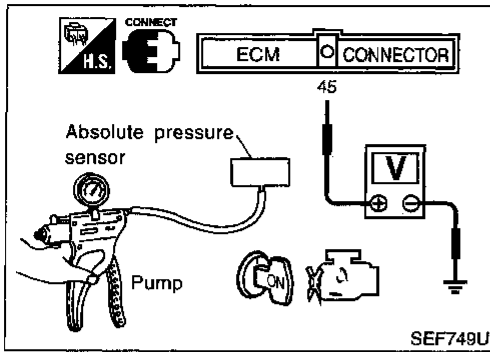

## Component Inspection

### ABSOLUTE PRESSURE SENSOR

NEEC0060

NEEC0060S01

1. Remove absolute pressure sensor with its harness connector connected.
2. Remove hose from absolute pressure sensor.
3. Turn ignition switch "ON" and check output voltage between ECM terminal 45 and engine ground.  
**The voltage should be 3.2 to 4.8V.**
4. Use pump to apply vacuum of  $-26.7$  kPa ( $-200$  mmHg,  $-7.87$  inHg) to absolute pressure sensor as shown in figure and check the output voltage.  
**The voltage should be 1.0 to 1.4V lower than the value measured in step 3.**

#### CAUTION:

- Always calibrate the vacuum pump gauge when using it.
  - Do not apply below  $-93.3$  kPa ( $-700$  mmHg,  $-27.56$  inHg) or over  $101.3$  kPa ( $760$  mmHg,  $29.92$  inHg) of pressure.
5. If NG, replace absolute pressure sensor.



# DTC P0110 INTAKE AIR TEMPERATURE SENSOR

Component Description

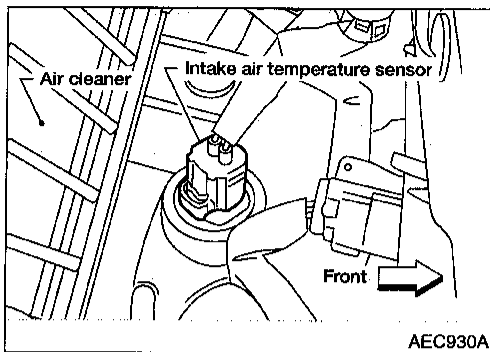

## Component Description

NEEC0081

The intake air temperature sensor is mounted to the air duct housing. The sensor detects intake air temperature and transmits a signal to the ECM.

The temperature sensing unit uses a thermistor which is sensitive to the change in temperature. Electrical resistance of the thermistor decreases in response to the temperature rise.

### <Reference data>

Intake air temperature °C (°F)	Voltage* (V)	Resistance kΩ
20 (68)	3.5	2.1 - 2.9
80 (176)	1.23	0.27 - 0.38

\*: These data are reference values and are measured between ECM terminal 61 (Intake air temperature sensor) and ECM terminal 32 (ECM ground).

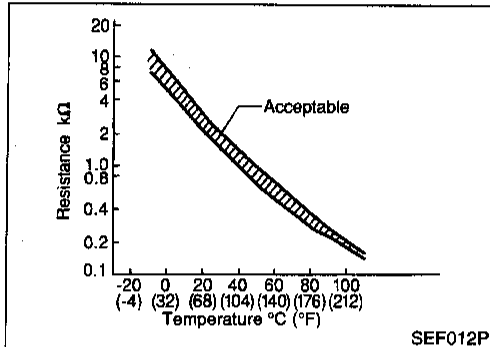

## On Board Diagnosis Logic

NEEC0082

DTC No.	Malfunction is detected when ...	Check Items (Possible Cause)
P0110 0401	A) An excessively low or high voltage from the sensor is sent to ECM.	<ul style="list-style-type: none"> <li>• Harness or connectors (The sensor circuit is open or shorted.)</li> <li>• Intake air temperature sensor</li> </ul>
	B) Rationally incorrect voltage from the sensor is sent to ECM, compared with the voltage signal from engine coolant temperature sensor.	

## DTC Confirmation Procedure

NEEC0083

Perform "PROCEDURE FOR MALFUNCTION A" first. If 1st trip DTC cannot be confirmed, perform "PROCEDURE FOR MALFUNCTION B".

### NOTE:

If "DTC Confirmation Procedure" has been previously conducted, always turn ignition switch "OFF" and wait at least 5 seconds before conducting the next test.

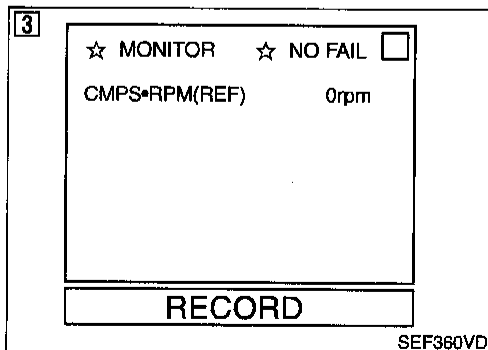

## PROCEDURE FOR MALFUNCTION A

NEEC0063S01

### ⓐ With CONSULT

- 1) Turn ignition switch "ON".
- 2) Select "DATA MONITOR" mode with CONSULT.
- 3) Wait at least 5 seconds.
- 4) If 1st trip DTC is detected, go to "Diagnostic Procedure", EC-143.

### ⓑ With GST

- 1) Turn ignition switch "ON" and wait at least 5 seconds.
- 2) Select MODE 7 with GST.

# DTC P0110 INTAKE AIR TEMPERATURE SENSOR

DTC Confirmation Procedure (Cont'd)

- 3) If 1st trip DTC is detected, go to "Diagnostic Procedure", EC-143.

## Ⓜ No Tools

- 1) Turn ignition switch "ON" and wait at least 5 seconds.
- 2) Turn ignition switch "OFF", wait at least 5 seconds and then turn "ON".
- 3) Perform "Diagnostic Test Mode II (Self-diagnostic results)" with ECM.
- 4) If 1st trip DTC is detected, go to "Diagnostic Procedure", EC-143.

5	☆ MONITOR ☆ NO FAIL
COOLAN TEMP/S	30°C
VHCL SPEED SE	75km/h
RECORD	

SEF233UA

FUEL SYS #1	OPEN
FUEL SYS #2	UNUSED
CALC LOAD	0%
COOLANT TEMP	28°C
SHORT FT #1	0%
LONG FT #1	0%
ENGINE SPD	0RPM
VEHICLE SPD	0km/h
IGN ADVANCE	5.0°
INTAKE AIR	25°C
MAF	0.0gm/sec
THROTTLE POS	0%
O2S LOCATION	3
O2S B1,S1	0.380V
O2FT B1,S1	0%
O2S B1,S2	0.000V

SEF950N

## PROCEDURE FOR MALFUNCTION B

NEEC0063S02

### CAUTION:

Always drive vehicle at a safe speed.

### TESTING CONDITION:

This test may be conducted with the drive wheels lifted in the shop or by driving the vehicle. If a road test is expected to be easier, it is unnecessary to lift the vehicle.

#### Ⓜ With CONSULT

- 1) Wait until engine coolant temperature is less than 90°C (194°F).
  - a) Turn ignition switch "ON".
  - b) Select "DATA MONITOR" mode with CONSULT.
  - c) Check the engine coolant temperature.
  - d) If the engine coolant temperature is not less than 90°C (194°F), turn ignition switch "OFF" and cool down engine.
    - Perform the following steps before engine coolant temperature is above 90°C (194°F).
- 2) Turn ignition switch "ON".
- 3) Select "DATA MONITOR" mode with CONSULT.
- 4) Start engine.
- 5) Hold vehicle speed at more than 70 km/h (43 MPH) for 100 consecutive seconds.
- 6) If 1st trip DTC is detected, go to "Diagnostic Procedure", EC-143.

#### Ⓜ With GST

- 1) Wait until engine coolant temperature is less than 90°C (194°F).
  - a) Turn ignition switch "ON".
  - b) Select MODE 1 with GST.
  - c) Check the engine coolant temperature.
  - d) If the engine coolant temperature is not less than 90°C (194°F), turn ignition switch "OFF" and cool down engine.
    - Perform the following steps before engine coolant temperature is above 90°C (194°F).
- 2) Start engine.
- 3) Hold vehicle speed at more than 70 km/h (43 MPH) for 100 consecutive seconds.
- 4) Select MODE 7 with GST.
- 5) If 1st trip DTC is detected, go to "Diagnostic Procedure", EC-143.

# DTC P0110 INTAKE AIR TEMPERATURE SENSOR

DTC Confirmation Procedure (Cont'd)

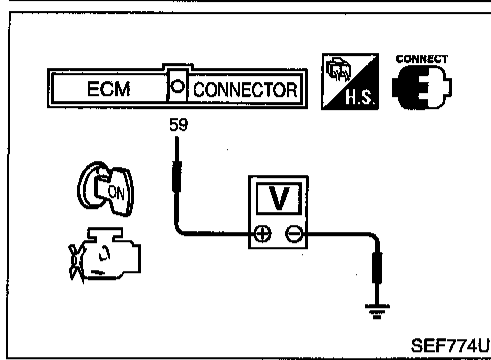

## Ⓜ No Tools

- 1) Wait until engine coolant temperature is less than 90°C (194°F).
- a) Turn ignition switch "ON".
- b) Check voltage between ECM terminal 59 (Engine coolant temperature sensor signal) and ground.  
**Voltage: More than 1.0V**
- c) If the voltage is not more than 1.0V, turn ignition switch "OFF" and cool down engine.
  - Perform the following steps before the voltage is below 1.0V.
- 2) Start engine.
- 3) Hold vehicle speed at more than 70 km/h (43 MPH) for 100 consecutive seconds.
- 4) Turn ignition switch "OFF", wait at least 5 seconds and then turn "ON".
- 5) Perform "Diagnostic Test Mode II (Self-diagnostic results)" with ECM.
- 6) If 1st trip DTC is detected, go to "Diagnostic Procedure", EC-143.

GI

MA

EM

LC

EC

FE

CL

MT

AT

TF

PD

FA

RA

BR

ST

RS

BT

HA

EL

IDX

# DTC P0110 INTAKE AIR TEMPERATURE SENSOR

Wiring Diagram

## Wiring Diagram

NEEC0064

EC-IATS-01

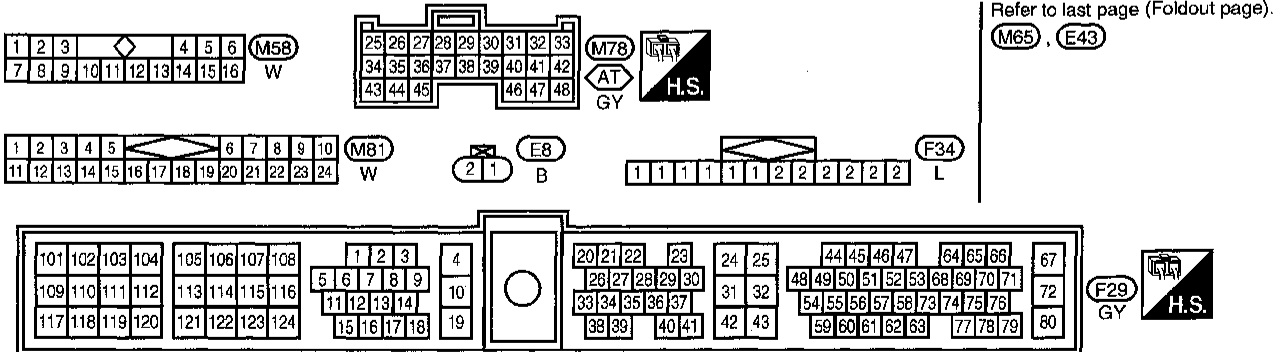
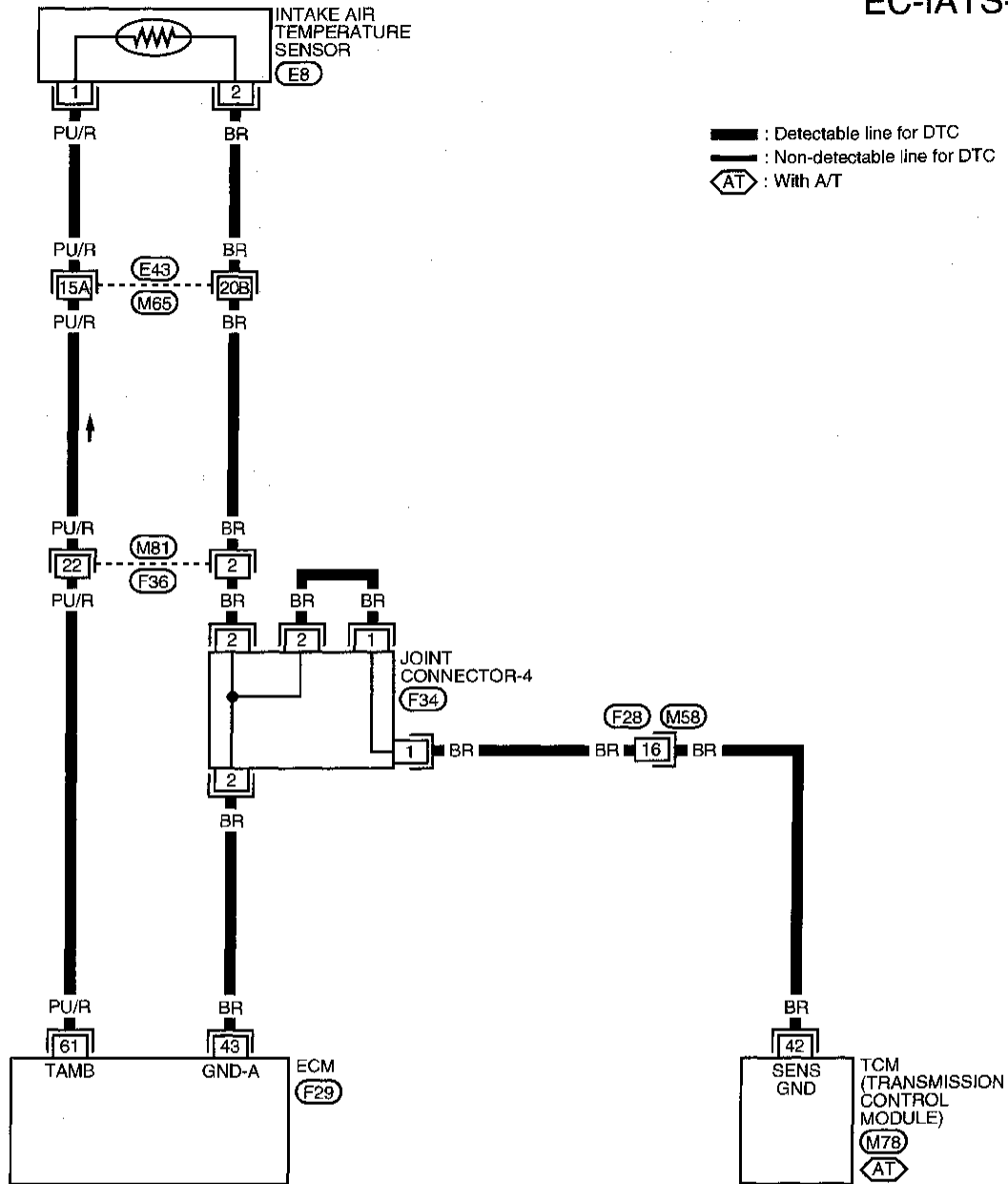

## Diagnostic Procedure

<b>1</b>	<b>CHECK POWER SUPPLY</b>
<ol style="list-style-type: none"> <li>Turn ignition switch "OFF".</li> <li>Disconnect intake air temperature sensor harness connector.</li> </ol>	
<ol style="list-style-type: none"> <li>Turn ignition switch "ON".</li> <li>Check voltage between terminal 1 and ground.</li> </ol>	
<p><b>Voltage: Approximately 5V</b></p> <p><b>OK or NG</b></p>	
OK	▶ GO TO 3.
NG	▶ GO TO 2.

<b>2</b>	<b>DETECT MALFUNCTIONING PART</b>
<p>Check the following.</p> <ul style="list-style-type: none"> <li>Harness connectors E43, M65</li> <li>Harness connectors M81, F36</li> <li>Harness for open or short between ECM and intake air temperature sensor</li> </ul>	
▶	Repair harness or connectors.

<b>3</b>	<b>CHECK GROUND CIRCUIT</b>
<ol style="list-style-type: none"> <li>Turn ignition switch "OFF".</li> <li>Check harness continuity between terminal 2 and engine ground.</li> </ol>	
<p><b>Continuity should exist.</b></p> <p>3. Also check harness for short to ground and short to power.</p> <p><b>OK or NG</b></p>	
OK	▶ GO TO 5.
NG	▶ GO TO 4.

<b>4</b>	<b>DETECT MALFUNCTIONING PART</b>
<p>Check the following.</p> <ul style="list-style-type: none"> <li>Harness connectors E43, M65</li> <li>Harness connectors M81, F36</li> <li>Harness connectors F28, M58</li> <li>Joint connector-4</li> <li>Harness for open or short between ECM and intake air temperature sensor</li> <li>Harness for open or short between TCM (Transmission Control Module) and intake air temperature sensor</li> </ul>	
▶	Repair open circuit or short to ground or short to power in harness or connectors.

<b>5</b>	<b>CHECK INTAKE AIR TEMPERATURE SENSOR</b>
<p>Refer to "Component Inspection", EC-144.</p> <p style="text-align: center;"><b>OK or NG</b></p>	
OK	▶ GO TO 6.
NG	▶ Replace intake air temperature sensor.

<b>6</b>	<b>CHECK INTERMITTENT INCIDENT</b>
<p>Refer to "TROUBLE DIAGNOSIS FOR INTERMITTENT INCIDENT", EC-115.</p>	
▶	<b>INSPECTION END</b>

GI  
MA  
EM  
LC  
EC  
FE  
CL  
MT  
AT  
TF  
PD  
FA  
RA  
BR  
ST  
RS  
BT  
HA  
EL  
IDX

# DTC P0110 INTAKE AIR TEMPERATURE SENSOR

## Component Inspection

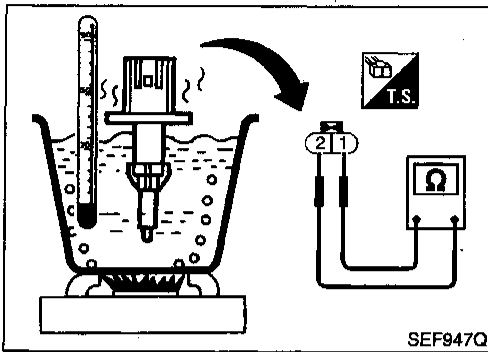

## Component Inspection INTAKE AIR TEMPERATURE SENSOR

Check resistance as shown in the figure.

NEEC0068  
NEEC0066S01

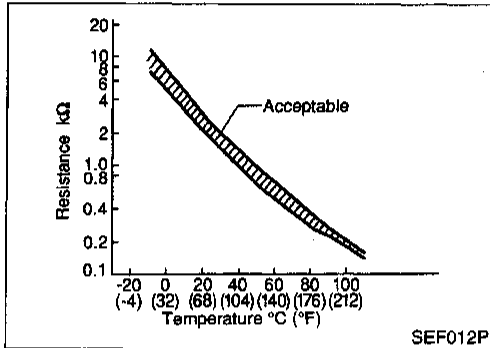

### <Reference data>

Intake air temperature °C (°F)	Resistance kΩ
20 (68)	2.1 - 2.9
80 (176)	0.27 - 0.38

If NG, replace intake air temperature sensor.

# DTC P0115 ENGINE COOLANT TEMPERATURE SENSOR (ECTS) (CIRCUIT)

Component Description

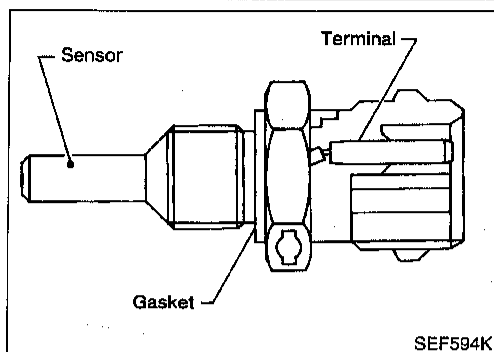

## Component Description

NEEC0067

The engine coolant temperature sensor is used to detect the engine coolant temperature. The sensor modifies a voltage signal from the ECM. The modified signal returns to the ECM as the engine coolant temperature input. The sensor uses a thermistor which is sensitive to the change in temperature. The electrical resistance of the thermistor decreases as temperature increases.

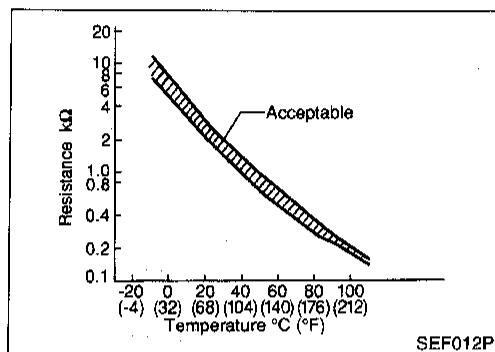

## <Reference data>

Engine coolant temperature °C (°F)	Voltage* (V)	Resistance (kΩ)
-10 (14)	4.4	7.0 - 11.4
20 (68)	3.5	2.1 - 2.9
50 (122)	2.2	0.68 - 1.00
90 (194)	0.9	0.236 - 0.260

\*: These data are reference values and are measured between ECM terminal 59 (Engine coolant temperature sensor) and ECM terminal 32 (ECM ground).

## On Board Diagnosis Logic

NEEC0068

DTC No.	Malfunction is detected when ...	Check Items (Possible Cause)
P0115 0103	<ul style="list-style-type: none"> <li>An excessively high or low voltage from the sensor is sent to ECM.*</li> </ul>	<ul style="list-style-type: none"> <li>Harness or connectors (The sensor circuit is open or shorted.)</li> <li>Engine coolant temperature sensor</li> </ul>

\*: When this malfunction is detected, the ECM enters fail-safe mode and the MIL lights up.

Detected items	Engine operating condition in fail-safe mode	
Engine coolant temperature sensor circuit	Engine coolant temperature will be determined by ECM based on the time after turning ignition switch "ON" or "START". CONSULT displays the engine coolant temperature decided by ECM.	
	Condition	Engine coolant temperature decided (CONSULT display)
	Just as ignition switch is turned ON or Start	40°C (104°F)
	More than approx. 4 minutes after ignition ON or Start	80°C (176°F)
	Except as shown above	40 - 80°C (104 - 176°F) (Depends on the time)

# DTC P0115 ENGINE COOLANT TEMPERATURE SENSOR (ECTS) (CIRCUIT)

## DTC Confirmation Procedure

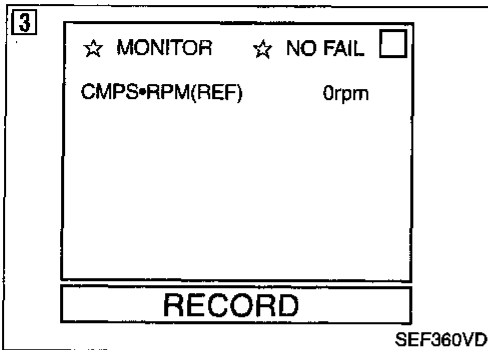

## DTC Confirmation Procedure

=NEEC0069

### NOTE:

If "DTC Confirmation Procedure" has been previously conducted, always turn ignition switch "OFF" and wait at least 5 seconds before conducting the next test.

#### ④ With CONSULT

- 1) Turn ignition switch "ON".
- 2) Select "DATA MONITOR" mode with CONSULT.
- 3) Wait at least 5 seconds.
- 4) If 1st trip DTC is detected, go to "Diagnostic Procedure", EC-148.

#### ④ With GST

- 1) Turn ignition switch "ON" and wait at least 5 seconds.
- 2) Select "MODE 7" with GST.
- 3) If 1st trip DTC is detected, go to "Diagnostic Procedure", EC-148.

#### ④ No Tools

- 1) Turn ignition switch "ON" and wait at least 5 seconds.
- 2) Turn ignition switch "OFF", wait at least 5 seconds and then turn "ON".
- 3) Perform "Diagnostic Test Mode II (Self-diagnostic results)" with ECM.
- 4) If 1st trip DTC is detected, go to "Diagnostic Procedure", EC-148.



# DTC P0115 ENGINE COOLANT TEMPERATURE SENSOR (ECTS) (CIRCUIT)

Wiring Diagram

## Wiring Diagram

NEEC0070

EC-ECTS-01

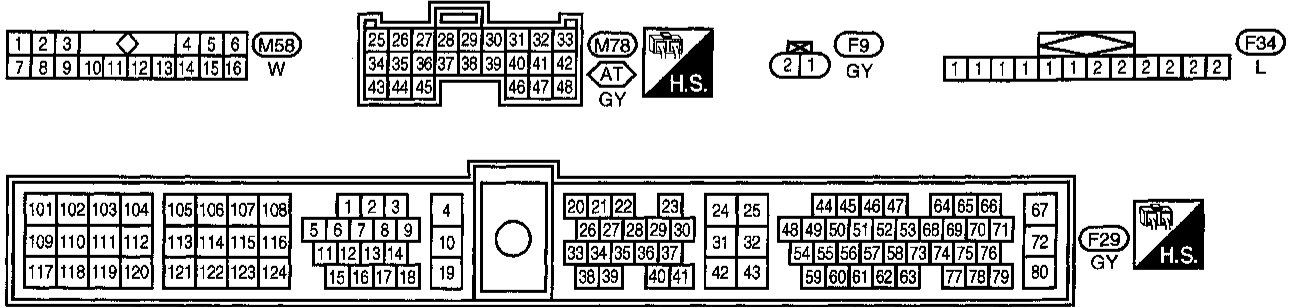
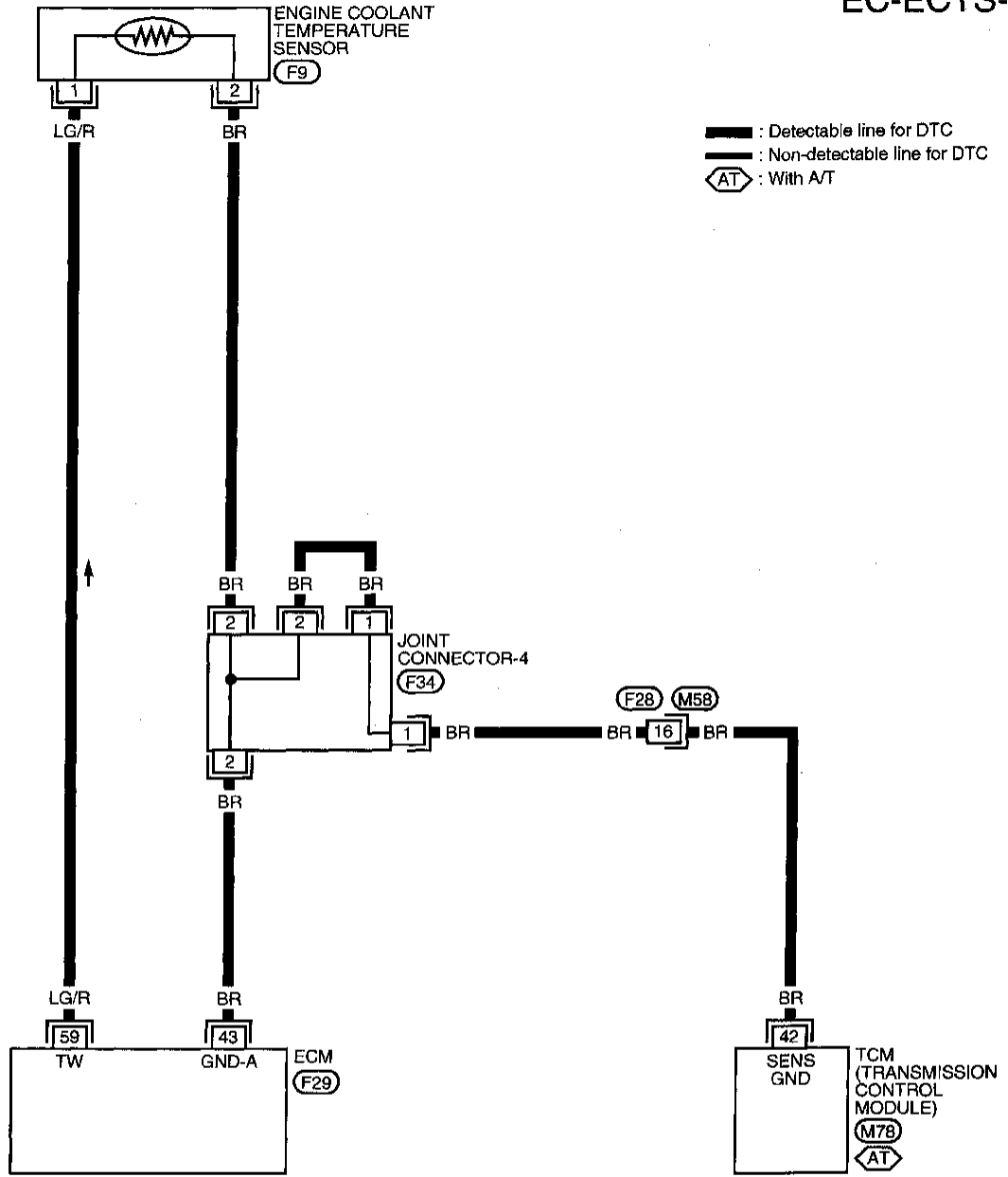

AEC756A

# DTC P0115 ENGINE COOLANT TEMPERATURE SENSOR (ECTS) (CIRCUIT)

Diagnostic Procedure

## Diagnostic Procedure

NEEC0071

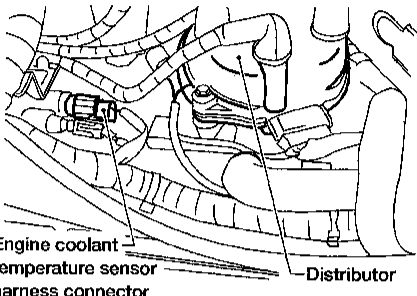
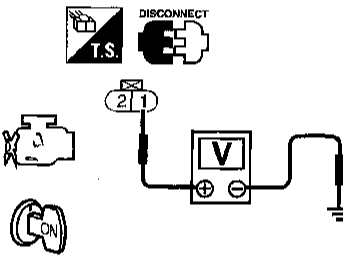
<b>1</b>	<b>CHECK POWER SUPPLY</b>
<ol style="list-style-type: none"> <li>Turn ignition switch "OFF".</li> <li>Disconnect engine coolant temperature sensor harness connector.</li> </ol>	
 <p>Engine coolant temperature sensor harness connector      Distributor</p> <p style="text-align: right;">AEC643A</p>	
<ol style="list-style-type: none"> <li>Turn ignition switch "ON".</li> <li>Check voltage between terminal 1 and ground with CONSULT or tester.</li> </ol>	
 <p style="text-align: right;">SEF206W</p>	
<p><b>Voltage: Approximately 5V</b></p> <p style="text-align: center;"><b>OK or NG</b></p>	
OK	▶ GO TO 2.
NG	▶ Repair open circuit or short to ground or short to power in harness or connectors.

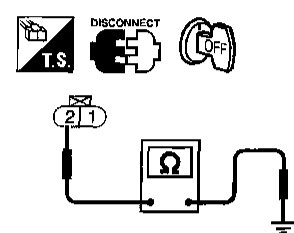
<b>2</b>	<b>CHECK GROUND CIRCUIT</b>
<ol style="list-style-type: none"> <li>Turn ignition switch "OFF".</li> <li>Check harness continuity between terminal 2 and engine ground.</li> </ol>	
 <p style="text-align: right;">SEF207W</p>	
<p><b>Continuity should exist.</b></p> <ol style="list-style-type: none"> <li>Also check harness for short to ground and short to power.</li> </ol> <p style="text-align: center;"><b>OK or NG</b></p>	
OK	▶ GO TO 4.
NG	▶ GO TO 3.

<b>3</b>	<b>DETECT MALFUNCTIONING PART</b>
<p>Check the following.</p> <ul style="list-style-type: none"> <li>• Harness connectors F28, M58</li> <li>• Joint connector-4</li> <li>• Harness for open or short between ECM and engine coolant temperature sensor</li> <li>• Harness for open or short between TCM (Transmission Control Module) and engine coolant temperature sensor</li> </ul>	
▶	Repair open circuit or short to ground or short to power in harness or connectors.

<b>4</b>	<b>CHECK ENGINE COOLANT TEMPERATURE SENSOR</b>
Refer to "Component Inspection", EC-149.	
<b>OK or NG</b>	
OK	▶ GO TO 5.
NG	▶ Replace engine coolant temperature sensor.

<b>5</b>	<b>CHECK INTERMITTENT INCIDENT</b>
Refer to "TROUBLE DIAGNOSIS FOR INTERMITTENT INCIDENT", EC-115.	
▶	<b>INSPECTION END</b>

# DTC P0115 ENGINE COOLANT TEMPERATURE SENSOR (ECTS) (CIRCUIT)

Component Inspection

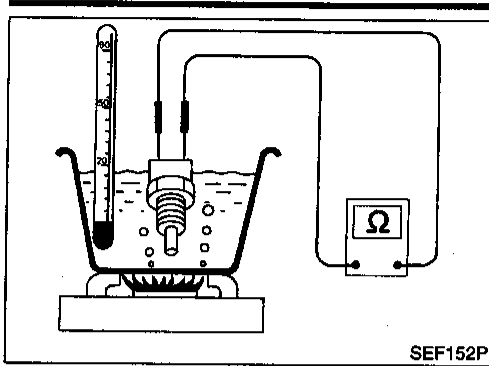

## Component Inspection

### ENGINE COOLANT TEMPERATURE SENSOR

Check resistance as shown in the figure.

NEEC0072

NEEC0072S01

#### <Reference data>

Temperature °C (°F)	Resistance kΩ
20 (68)	2.1 - 2.9
50 (122)	0.68 - 1.00
90 (194)	0.236 - 0.260

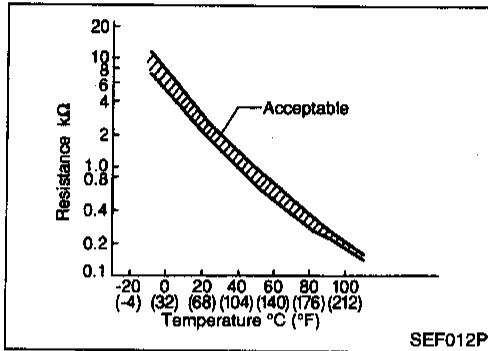

If NG, replace engine coolant temperature sensor.

GI  
MA  
EM  
LC  
EC  
FE  
CL  
MT  
AT  
TF  
PD  
FA  
RA  
BR  
ST  
RS  
BT  
HA  
EL  
IDX

# DTC P0120 THROTTLE POSITION SENSOR

Description

## Description

NEEC0073

### NOTE:

If DTC P0120 (0403) is displayed with DTC P0510 (0203), first perform the trouble diagnosis for DTC P0510. Refer to EC-342.

### COMPONENT DESCRIPTION

NEEC0073S01

The throttle position sensor responds to the accelerator pedal movement. This sensor is a kind of potentiometer which transforms the throttle position into output voltage, and emits the voltage signal to the ECM. In addition, the sensor detects the opening and closing speed of the throttle valve and feeds the voltage signal to the ECM.

Idle position of the throttle valve is determined by the ECM receiving the signal from the throttle position sensor. This sensor controls engine operation such as fuel cut. On the other hand, the "Wide open and closed throttle position switch", which is built into the throttle position sensor unit, is not used for engine control.

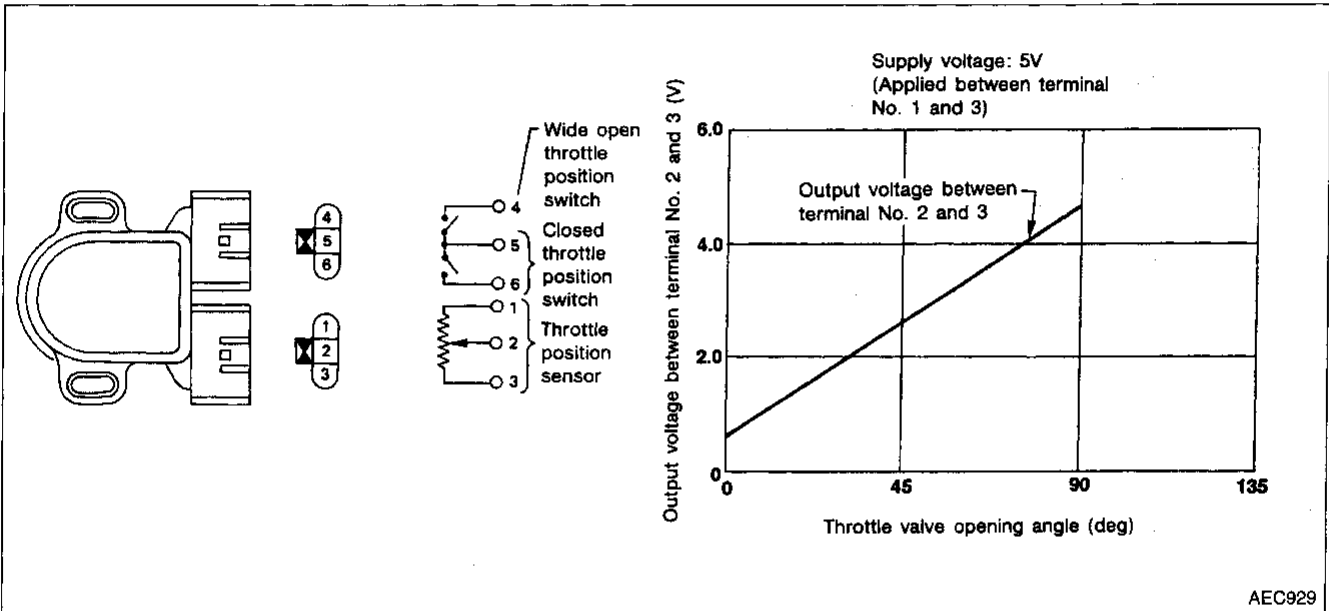

## CONSULT Reference Value in Data Monitor Mode

NEEC0074

Specification data are reference values.

MONITOR ITEM	CONDITION	SPECIFICATION	
THRTL POS SEN	<ul style="list-style-type: none"> <li>Engine: After warming up, idle the engine</li> </ul> Throttle valve: fully closed	0.4 - 0.6V	
	<ul style="list-style-type: none"> <li>Engine: After warming up</li> <li>Ignition switch: ON (Engine stopped)</li> </ul>	Throttle valve: Partially open	0.5 - 0.7V
		Throttle valve: fully opened	Approx. 4.0V
ABSOL TH-P/S	<ul style="list-style-type: none"> <li>Engine: After warming up, idle the engine</li> </ul> Throttle valve: fully closed	0.0%	
	<ul style="list-style-type: none"> <li>Engine: After warming up</li> <li>Ignition switch: ON (Engine stopped)</li> </ul> Throttle valve: fully opened	Approx. 80%	

## ECM Terminals and Reference Value

NEEC0075

Specification data are reference values and are measured between each terminal and 32 (ECM ground).

# DTC P0120 THROTTLE POSITION SENSOR

*ECM Terminals and Reference Value (Cont'd)*

TERMI- NAL NO.	WIRE COLOR	ITEM	CONDITION	DATA (DC Voltage)
23	L	Throttle position sensor	[Engine is running] • Warm-up condition • Accelerator pedal fully released	0.4 - 0.6V
			[Ignition switch "ON"] • Accelerator pedal fully depressed	Approximately 4V
42	B/W	Sensors' power supply	[Ignition switch "ON"]	Approximately 5V
43	BR	Sensors' ground	[Engine is running] • Warm-up condition • Idle speed	Approximately 0V

## On Board Diagnosis Logic

NEEC0076

DTC No.	Malfunction is detected when ...	Check Items (Possible Cause)
P0120 0403	A) An excessively low or high voltage from the sensor is sent to ECM*.	<ul style="list-style-type: none"> <li>• Harness or connectors (The throttle position sensor circuit is open or shorted.)</li> <li>• Throttle position sensor</li> </ul>
	B) A high voltage from the sensor is sent to ECM under light load driving conditions.	<ul style="list-style-type: none"> <li>• Harness or connectors (The throttle position sensor circuit is open or shorted.)</li> <li>• Throttle position sensor</li> <li>• Fuel injector</li> <li>• Camshaft position sensor</li> <li>• Mass air flow sensor</li> </ul>
	C) A low voltage from the sensor is sent to ECM under heavy load driving conditions.	<ul style="list-style-type: none"> <li>• Harness or connectors (The throttle position sensor circuit is open or shorted.)</li> <li>• Intake air leaks</li> <li>• Throttle position sensor</li> </ul>

\*: When this malfunction is detected, the ECM enters fail-safe mode and the MIL lights up.

Detected items	Engine operating condition in fail-safe mode	
Throttle position sensor circuit	Throttle position will be determined based on the injected fuel amount and the engine speed. Therefore, acceleration will be poor.	
	Condition	Driving condition
	When engine is idling	Normal
	When accelerating	Poor acceleration

## DTC Confirmation Procedure

NEEC0077

### NOTE:

- Perform "PROCEDURE FOR MALFUNCTION A" first. If the 1st trip DTC cannot be confirmed, perform "PROCEDURE FOR MALFUNCTION B".  
If there is no problem on "PROCEDURE FOR MALFUNCTION B", perform "PROCEDURE FOR MALFUNCTION C".
- If "DTC Confirmation Procedure" has been previously conducted, always turn ignition switch "OFF" and wait at least 5 seconds before conducting the next test.

# DTC P0120 THROTTLE POSITION SENSOR

DTC Confirmation Procedure (Cont'd)

## PROCEDURE FOR MALFUNCTION A

NEEC0077S01

### CAUTION:

Always drive vehicle at a safe speed.

### TESTING CONDITION:

- Before performing the following procedure, confirm that battery voltage is more than 10V at idle.
- This test may be conducted with the drive wheels lifted in the shop or by driving the vehicle. If a road test is expected to be easier, it is unnecessary to lift the vehicle.

2

☆ MONITOR    ☆ NO FAIL

CMPS•RPM(REF)	1575rpm
VHCL SPEED SE	20km/h
P/N POSI SW	OFF

RECORD

SEF775UA

### ② With CONSULT

- 1) Turn ignition switch "ON" and select "DATA MONITOR" mode with CONSULT.
- 2) Start engine and maintain the following conditions for at least 5 consecutive seconds.

Vehicle speed	More than 4 km/h (2 MPH)
Selector lever	Suitable position except "P" or "N" position

- 3) If 1st trip DTC is detected, go to "Diagnostic Procedure", EC-157.

### ③ With GST

- 1) Start engine and maintain the following conditions for at least 5 consecutive seconds.

Vehicle speed	More than 4 km/h (2 MPH)
Selector lever	Suitable position except "P" or "N" position

- 2) Select "MODE 7" with GST.
- 3) If 1st trip DTC is detected, go to "Diagnostic Procedure", EC-157.

### ④ No Tools

- 1) Start engine and maintain the following conditions for at least 5 consecutive seconds.

Vehicle speed	More than 4 km/h (2 MPH)
Selector lever	Suitable position except "P" or "N" position

- 2) Turn ignition switch "OFF" and wait at least 5 seconds.
- 3) Turn ignition switch "ON" and perform "Diagnostic Test Mode II (Self-diagnostic results)" with ECM.
- 4) If 1st trip DTC is detected, go to "Diagnostic Procedure", EC-157.

## PROCEDURE FOR MALFUNCTION B

NEEC0077S02

### ② With CONSULT

- 1) Turn ignition switch "ON".
- 2) Select "DATA MONITOR" mode with CONSULT.
- 3) Start engine and let it idle for at least 10 seconds. If idle speed is over 1,000 rpm, maintain the following conditions for at least 10 seconds to keep engine speed below 1,000 rpm.

3

☆ MONITOR    ☆ NO FAIL

CMPS•RPM(REF)	750 rpm
---------------	---------

RECORD

SEF357VA

# DTC P0120 THROTTLE POSITION SENSOR

DTC Confirmation Procedure (Cont'd)

Selector lever	Suitable position except "P" or "N"
Brake pedal	Depressed
Vehicle speed	0 km/h (0 MPH)

- 4) If 1st trip DTC is detected, go to "Diagnostic Procedure", EC-157.

**With GST**

- 1) Start engine and let it idle for at least 10 seconds. If idle speed is over 1,000 rpm, maintain the following conditions for at least 10 seconds to keep engine speed below 1,000 rpm.

Selector lever	Suitable position except "P" or "N"
Brake pedal	Depressed
Vehicle speed	0 km/h (0 MPH)

- 2) Select "MODE 7" with GST.
- 3) If 1st trip DTC is detected, go to "Diagnostic Procedure", EC-157.

**No Tools**

- 1) Start engine and let it idle for at least 10 seconds. If idle speed is over 1,000 rpm, maintain the following conditions for at least 10 seconds to keep engine speed below 1,000 rpm.

Selector lever	Suitable position except "P" or "N"
Brake pedal	Depressed
Vehicle speed	0 km/h (0 MPH)

- 2) Turn ignition switch "OFF" and wait at least 5 seconds.
- 3) Turn ignition switch "ON" and perform "Diagnostic Test Mode II (Self-diagnostic results)" with ECM.
- 4) If 1st trip DTC is detected, go to "Diagnostic Procedure", EC-157.

GI  
MA  
EM  
LC  
EC  
FE  
CL  
MT  
AT  
TF  
PD  
FA  
RA  
BR  
ST  
RS  
BT  
HA  
EL  
IDX

# DTC P0120 THROTTLE POSITION SENSOR

DTC Confirmation Procedure (Cont'd)

NEEC0077503

**6** ☆ MONITOR ☆ NO FAIL

THRTL POS SEN 0.48V  
ABSOL TH•P/S 0.0%

**RECORD**

SEF024PC

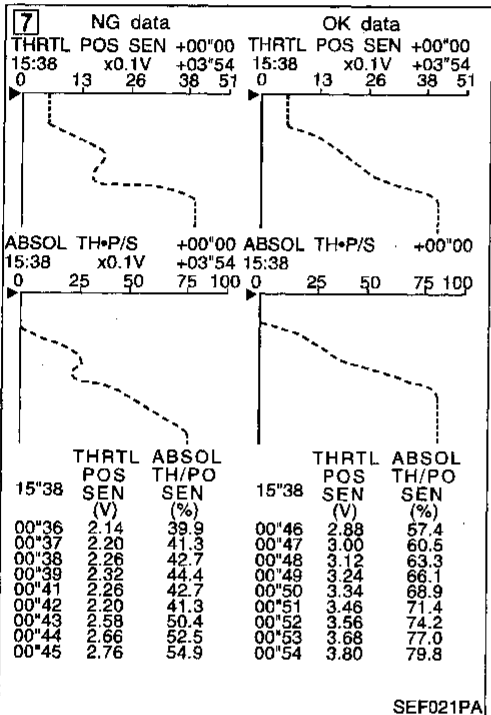

**9** ☆ MONITOR ☆ NO FAIL

CMPS•RPM(REF) 2137rpm  
MAS AIR/FL SE 3.07V  
COOLAN TEMP/S 84°C  
IACV-AAC/V 72%

**RECORD**

SEF776UA

## PROCEDURE FOR MALFUNCTION C

### CAUTION:

Always drive vehicle at a safe speed.

### Ⓟ With CONSULT

- 1) Start engine and warm it up to normal operating temperature.
- 2) Turn ignition switch "OFF" and wait at least 5 seconds.
- 3) Turn ignition switch "ON".
- 4) Select "MANU TRIG" and "HI SPEED" in "DATA MONITOR" mode with CONSULT.
- 5) Select "THRTL POS SEN" and "ABSOL TH•P/S" in "DATA MONITOR" mode with CONSULT.
- 6) Press RECORD on CONSULT SCREEN at the same time accelerator pedal is depressed.
- 7) Print out the recorded graph and check the following:
  - The voltage rise is linear in response to accelerator pedal depression.
  - The voltage when accelerator pedal is fully depressed is approximately 4V.
 If NG, go to "Diagnostic Procedure", EC-157.  
If OK, go to following step.
- 8) Select "AUTO TRIG" in "DATA MONITOR" mode with CONSULT.
- 9) Maintain the following conditions for at least 10 consecutive seconds.

CMPS•RPM (REF)	More than 2,000 rpm
MAS AIR/FL SE	More than 3V
COOLAN TEMP/S	More than 70°C (158°F)
IACV-AAC/V	Less than 80%
Selector lever	Suitable position
Driving location	Driving vehicle uphill (Increased engine load) will help maintain the driving conditions required for this test.

- 10) If 1st trip DTC is detected, go to "Diagnostic Procedure", EC-157.



# DTC P0120 THROTTLE POSITION SENSOR

DTC Confirmation Procedure (Cont'd)

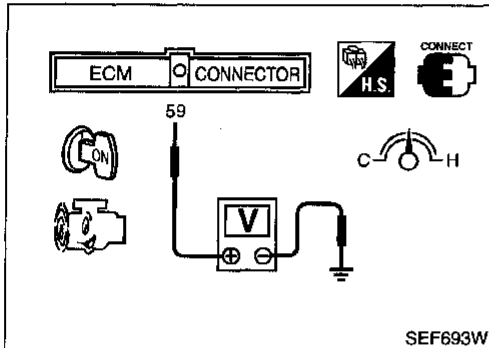
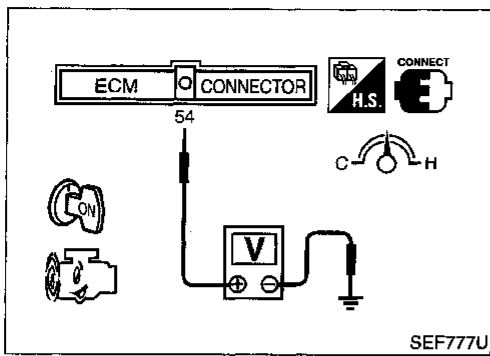

## With GST

- 1) Start engine and warm it up to normal operating temperature.
- 2) Maintain the following conditions for at least 10 consecutive seconds.

Gear position	Suitable position
Engine speed	More than 2,000 rpm
Engine coolant temperature	More than 70°C (159°F)
Voltage between ECM terminal 54 (Mass air flow sensor signal) and ground	More than 3V

- 3) Select "MODE 7" with GST.

- 4) If 1st trip DTC is detected, go to "Diagnostic Procedure", EC-157.

## No Tools

- 1) Start engine and warm it up to normal operating temperature.
- 2) Maintain the following conditions for at least 10 consecutive seconds.

Gear position	Suitable position.
Engine speed	More than 2,000 rpm
Voltage between ECM terminal 54 (Mass air flow sensor signal) and ground	More than 3V
Voltage between ECM terminal 59 (Engine coolant temperature sensor signal) and ground	Less than 1.5V

- 3) Stop the vehicle, turn ignition switch "OFF", wait at least 5 seconds and then turn "ON".
- 4) Perform "Diagnostic Test Mode II (Self-diagnostic results)" with ECM.
- 5) If 1st trip DTC is detected, go to "Diagnostic Procedure", EC-157.

GI  
MA  
EM  
LC  
EC  
FE  
CL  
MT  
AT  
TF  
PD  
FA  
RA  
BR  
ST  
RS  
BT  
HA  
EL  
IDX

# DTC P0120 THROTTLE POSITION SENSOR

Wiring Diagram

## Wiring Diagram

NEEC0078

EC-TPS-01

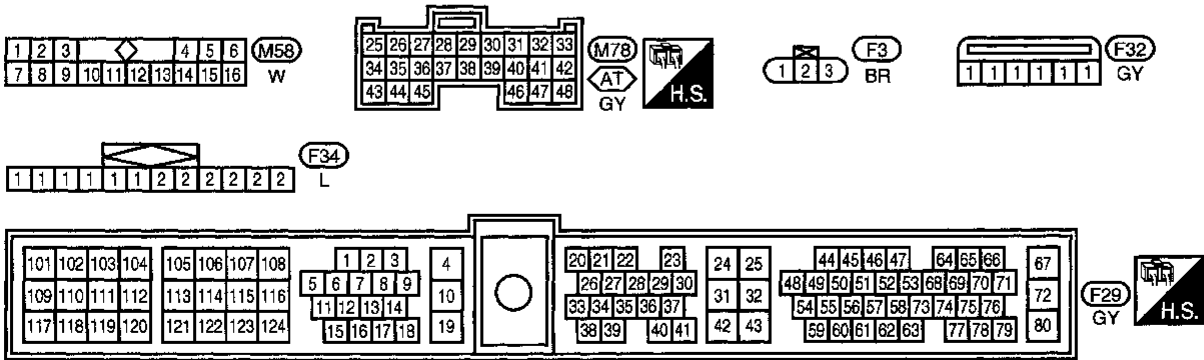
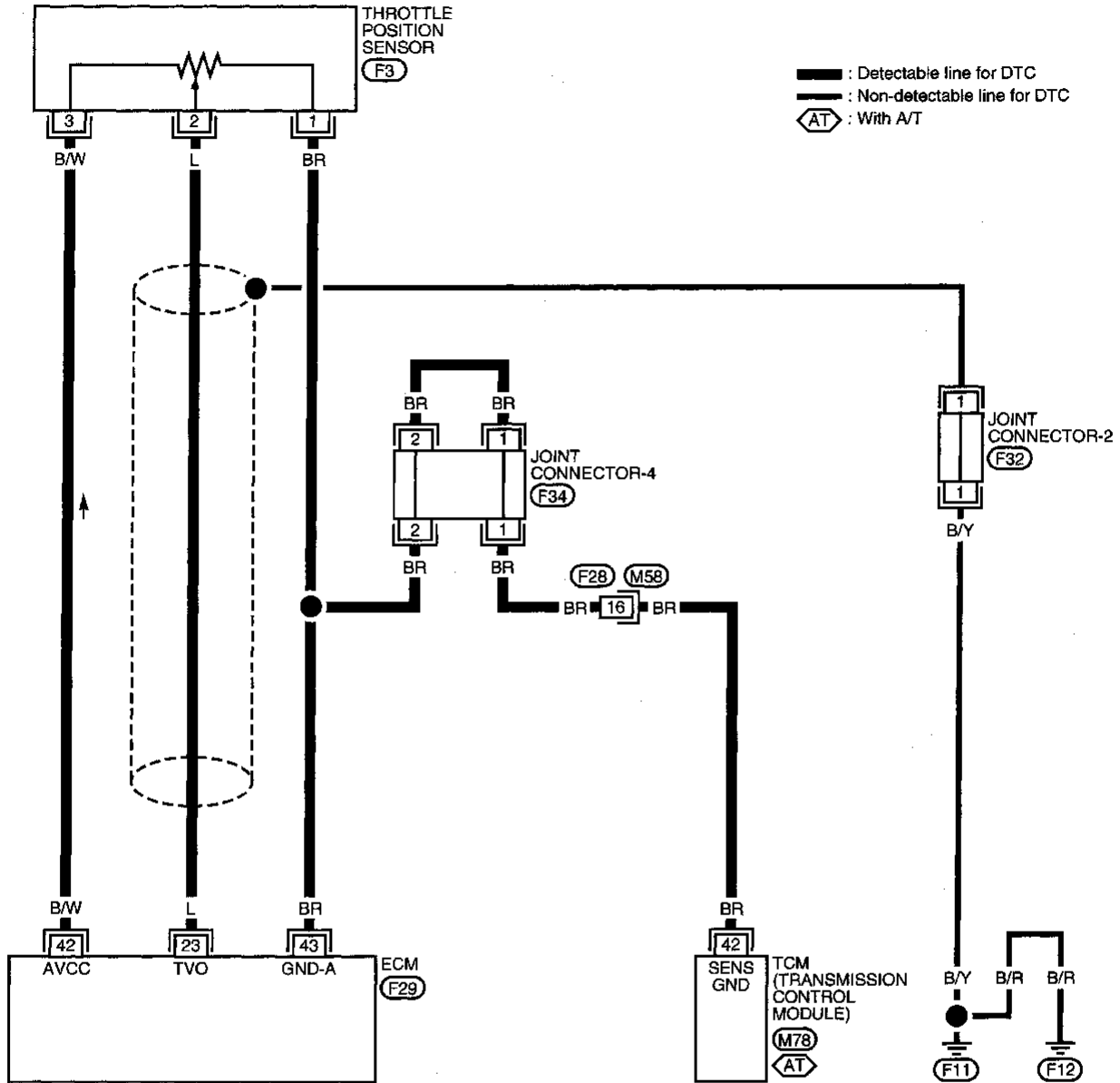

AEC757A

# DTC P0120 THROTTLE POSITION SENSOR

Diagnostic Procedure

## Diagnostic Procedure

NEEC0079

<b>1</b>	<b>INSPECTION START</b>								
Which malfunction A, B or C is duplicated?									
<table border="1"> <thead> <tr> <th>MALFUNCTION</th> <th>Type</th> </tr> </thead> <tbody> <tr> <td>A</td> <td>A</td> </tr> <tr> <td>B</td> <td>B</td> </tr> <tr> <td>C</td> <td>C</td> </tr> </tbody> </table>		MALFUNCTION	Type	A	A	B	B	C	C
MALFUNCTION	Type								
A	A								
B	B								
C	C								
MTBL0066									
<b>Type A, B or C</b>									
Type A or B	▶ GO TO 4.								
Type C	▶ GO TO 2.								

<b>2</b>	<b>ADJUST THROTTLE POSITION SENSOR</b>
Perform "Basic Inspection", EC-86.	
▶ GO TO 3.	

<b>3</b>	<b>CHECK INTAKE SYSTEM.</b>
<ol style="list-style-type: none"> <li>Turn ignition switch "OFF".</li> <li>Check the following for connection. <ul style="list-style-type: none"> <li>Air duct</li> <li>Vacuum hoses</li> <li>Intake air passage between air duct to intake manifold collector</li> </ul> </li> </ol>	
<b>OK or NG</b>	
OK	▶ GO TO 4.
NG	▶ Reconnect the parts.

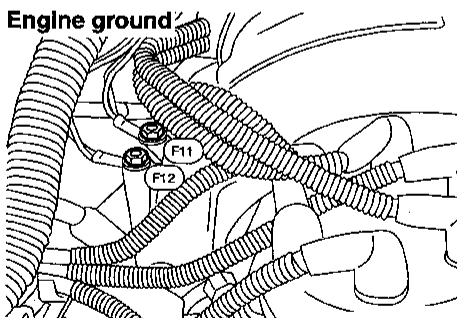
<b>4</b>	<b>RETIGHTEN GROUND SCREWS</b>
<ol style="list-style-type: none"> <li>Turn ignition switch "OFF".</li> <li>Loosen and retighten engine ground screws.</li> </ol>	
 <p style="text-align: right;">AEC640A</p>	
▶ GO TO 5.	

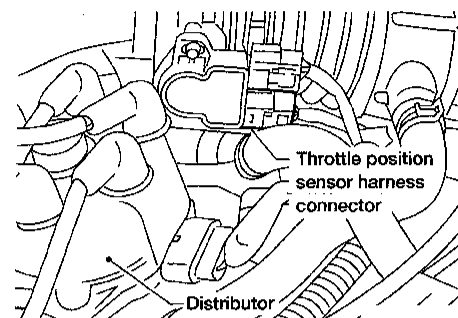
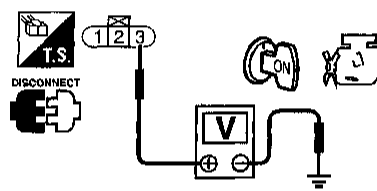
<b>5</b>	<b>CHECK POWER SUPPLY</b>
<ol style="list-style-type: none"> <li>Disconnect throttle position sensor harness connector.</li> </ol>	
 <p style="text-align: right;">AEC638A</p>	
<ol style="list-style-type: none"> <li>Turn ignition switch "ON".</li> <li>Check voltage between terminal 3 and ground with CONSULT or tester.</li> </ol>	
 <p style="text-align: center;"><b>Voltage: Approximately 5V</b></p> <p style="text-align: right;">SEF630W</p>	
<b>OK or NG</b>	
OK	▶ GO TO 6.
NG	▶ Repair open circuit or short to ground or short to power in harness or connectors.

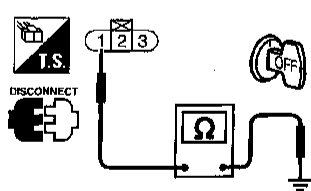
<b>6</b>	<b>CHECK GROUND CIRCUIT</b>
<ol style="list-style-type: none"> <li>Turn ignition switch "OFF".</li> <li>Check harness continuity between terminal 1 and engine ground.</li> </ol>	
 <p style="text-align: right;">SEF631W</p>	
<b>Continuity should exist.</b>	
<ol style="list-style-type: none"> <li>Also check harness for short to ground and short to power.</li> </ol>	
<b>OK or NG</b>	
OK	▶ GO TO 8.
NG	▶ GO TO 7.

GI  
MA  
EM  
LC  
EC  
FE  
CL  
MT  
AT  
TF  
PD  
FA  
RA  
BR  
ST  
RS  
BT  
HA  
EL  
IDX

# DTC P0120 THROTTLE POSITION SENSOR

Diagnostic Procedure (Cont'd)

<b>7</b>	<b>DETECT MALFUNCTIONING PART</b>
<p>Check the following.</p> <ul style="list-style-type: none"> <li>• Harness connectors F28, M58</li> <li>• Joint connector-4</li> <li>• Harness for open or short between ECM and throttle position sensor</li> <li>• Harness for open or short between TCM (Transmission Control Module) and throttle position sensor</li> </ul>	
▶	Repair open circuit or short to ground or short to power in harness or connectors.

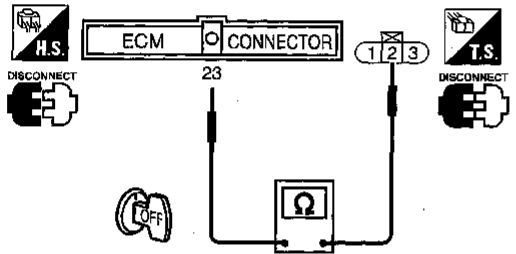
<b>8</b>	<b>CHECK INPUT SIGNAL CIRCUIT</b>
<ol style="list-style-type: none"> <li>1. Disconnect ECM harness connector.</li> <li>2. Check harness continuity between ECM terminal 23 and terminal 2.</li> </ol>	
	
<p><b>Continuity should exist.</b></p>	
<ol style="list-style-type: none"> <li>3. Also check harness for short to ground and short to power.</li> </ol>	
<b>OK or NG</b>	
OK	▶ GO TO 9.
NG	▶ Repair open circuit or short to ground or short to power in harness or connectors.

<b>9</b>	<b>CHECK THROTTLE POSITION SENSOR</b>
Refer to "Component Inspection" EC-159.	
<b>OK or NG</b>	
OK	▶ GO TO 10.
NG	▶ Replace throttle position sensor. To adjust it, perform "Basic Inspection", EC-86.

<b>10</b>	<b>CHECK MASS AIR FLOW SENSOR</b>
Refer to "Component Inspection", EC-129.	
<b>OK or NG</b>	
OK	▶ GO TO 11.
NG	▶ Replace mass air flow sensor.

<b>11</b>	<b>CHECK CAMSHAFT POSITION SENSOR</b>
Refer to "Component Inspection", EC-286.	
<b>OK or NG</b>	
OK	▶ GO TO 12.
NG	▶ Replace camshaft position sensor.

<b>12</b>	<b>CHECK FUEL INJECTOR</b>
Refer to "Component Inspection", EC-462.	
<b>OK or NG</b>	
OK	▶ GO TO 13.
NG	▶ Replace fuel injector.

<b>13</b>	<b>CHECK SHIELD CIRCUIT</b>
<ol style="list-style-type: none"> <li>1. Turn ignition switch "OFF".</li> <li>2. Disconnect joint connector-2.</li> <li>3. Check the following. <ul style="list-style-type: none"> <li>• Continuity between joint connector terminal and ground</li> <li>• Joint connector (Refer to "HARNES LAYOUT" in EL section.)</li> </ul> </li> <li>4. Also check harness for short to ground and short to power.</li> <li>5. Then reconnect joint connector-2.</li> </ol>	
<b>Continuity should exist.</b>	
<b>OK or NG</b>	
OK	▶ GO TO 14.
NG	▶ Repair open circuit or short to ground or short to power in harness or connectors.

<b>14</b>	<b>CHECK INTERMITTENT INCIDENT</b>
Refer to "TROUBLE DIAGNOSIS FOR INTERMITTENT INCIDENT", EC-115.	
▶ <b>INSPECTION END</b>	

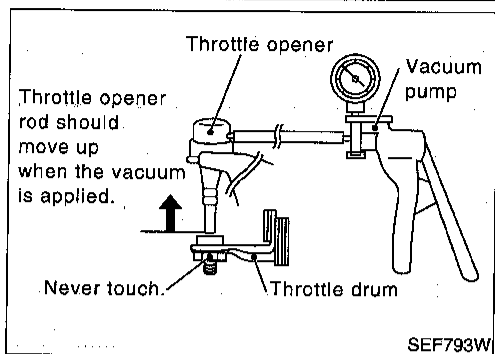

## Component Inspection THROTTLE POSITION SENSOR

=NEEC0080

NEEC0080S01

### ④ With CONSULT

- 1) Start engine and warm it up to normal operating temperature.
- 2) Stop engine (ignition switch OFF).
- 3) Remove the vacuum hose connected to the throttle opener.
- 4) Connect suitable vacuum hose to the vacuum pump and the opener.
- 5) Apply vacuum [more than -40.0kPa (-300mmHg, 11.81inHG)] until the throttle drum becomes free from the rod of the throttle opener.
- 6) Turn ignition switch ON.

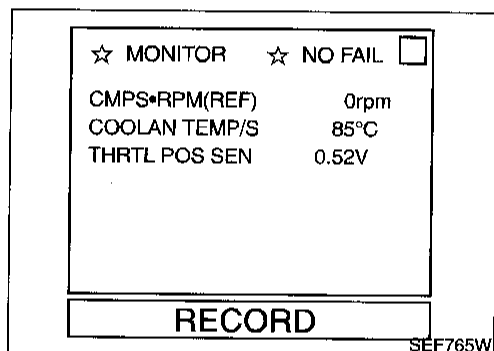

- 7) Select "DATA MONITOR" mode with CONSULT.
- 8) Check voltage of "THRTL POS SEN".  
**Voltage measurement must be made with throttle position sensor installed in vehicle.**

Throttle valve conditions	THRTL POS SEN
Completely closed (a)	0.15 - 0.85V
Partially open	Between (a) and (b)
Completely open (b)	3.5 - 4.7V

If NG, adjust closed throttle position switch. Refer to "Basic Inspection", EC-86.

- 9) If it is impossible to adjust closed throttle position switch in "Basic Inspection", replace throttle position sensor.

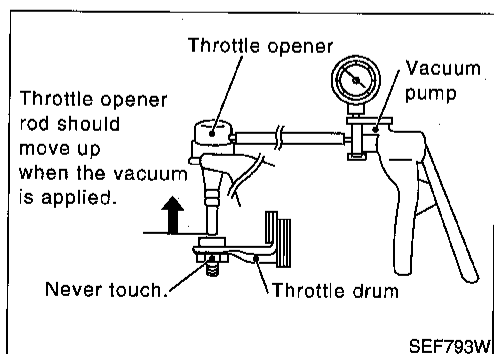

### ④ Without Tools

- 1) Start engine and warm it up to normal operating temperature.
- 2) Stop engine (ignition switch OFF).
- 3) Remove the vacuum hose connected to the throttle opener.
- 4) Connect suitable vacuum hose to the vacuum pump and the opener.
- 5) Apply vacuum [more than -40.0kPa (-300mmHg, 11.81inHG)] until the throttle drum becomes free from the rod of the throttle opener.
- 6) Turn ignition switch ON.
- 7) Check voltage between ECM terminal 23 (Throttle position

**EC-159**

GI  
MA  
EM  
LC  
EC  
FE  
CL  
MT  
AT  
TF  
PD  
FA  
RA  
BR  
ST  
RS  
BT  
HA  
EL  
IDX

## DTC P0120 THROTTLE POSITION SENSOR

### Component Inspection (Cont'd)

sensor signal) and ground.

**Voltage measurement must be made with throttle position sensor installed in vehicle.**

Throttle valve conditions	Voltage
Completely closed (a)	0.15 - 0.85V
Partially open	Between (a) and (b)
Completely open (b)	3.5 - 4.7V

If NG, adjust closed throttle position switch. Refer to "Basic Inspection", EC-86.

- 8) If it is impossible to adjust closed throttle position switch in "Basic Inspection", replace throttle position sensor.

# DTC P0125 ENGINE COOLANT TEMPERATURE (ECT) SENSOR

Description

## Description

NEEC0081

### NOTE:

If DTC P0125 (0908) is displayed with P0115 (0103), first perform the trouble diagnosis for DTC P0115. Refer to EC-145.

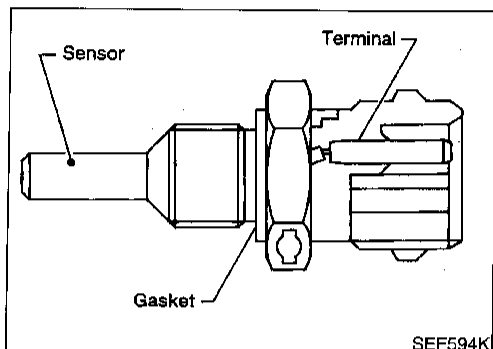

## COMPONENT DESCRIPTION

NEEC0081S01

The engine coolant temperature sensor is used to detect the engine coolant temperature. The sensor modifies a voltage signal from the ECM. The modified signal returns to the ECM as the engine coolant temperature input. The sensor uses a thermistor which is sensitive to the change in temperature. The electrical resistance of the thermistor decreases as temperature increases.

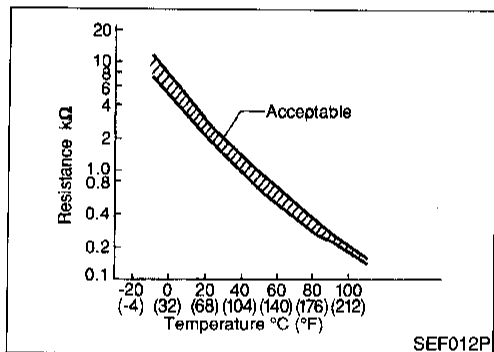

### <Reference data>

Engine coolant temperature °C (°F)	Voltage* (V)	Resistance (kΩ)
-10 (14)	4.4	9.2
20 (68)	3.5	2.1 - 2.9
50 (122)	2.2	0.68 - 1.00
90 (194)	0.9	0.236 - 0.260

\*: These data are reference values and are measured between ECM terminal 59 (Engine coolant temperature sensor) and ECM terminal 32 (ECM ground).

## On Board Diagnosis Logic

NEEC0082

DTC No.	Malfunction is detected when ...	Check Items (Possible Cause)
P0125 0908	<ul style="list-style-type: none"> <li>• Voltage sent to ECM from the sensor is not practical, even when some time has passed after starting the engine.</li> <li>• Engine coolant temperature is insufficient for closed loop fuel control.</li> </ul>	<ul style="list-style-type: none"> <li>• Harness or connectors (High resistance in the circuit)</li> <li>• Engine coolant temperature sensor</li> <li>• Thermostat</li> </ul>

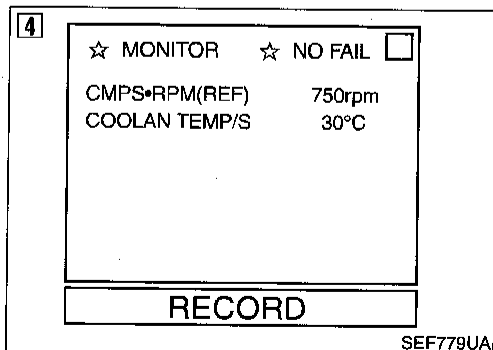

## DTC Confirmation Procedure

NEEC0083

### CAUTION:

Be careful not to overheat engine.

### NOTE:

If "DTC Confirmation Procedure" has been previously conducted, always turn ignition switch "OFF" and wait at least 5 seconds before conducting the next test.

#### With CONSULT

- 1) Turn ignition switch "ON".
- 2) Select "DATA MONITOR" mode with CONSULT.

## DTC P0125 ENGINE COOLANT TEMPERATURE (ECT) SENSOR

DTC Confirmation Procedure (Cont'd)

- 3) Check that "COOLAN TEMP/S" is above 10°C (50°F).  
**If it is above 10°C (50°F), the test result will be OK.**  
**If it is below 10°C (50°F), go to following step.**
- 4) Start engine and run it for 65 minutes at idle speed.  
**If "COOLAN TEMP/S" increases to more than 10°C (50°F) within 65 minutes, stop engine because the test result will be OK.**
- 5) If 1st trip DTC is detected, go to "Diagnostic Procedure", EC-164.

### With GST

- 1) Turn ignition switch "ON".
- 2) Select "MODE 1" with GST.
- 3) Check that engine coolant temperature is above 10°C (50°F).  
**If it is above 10°C (50°F), the test result will be OK.**  
**If it is below 10°C (50°F), go to following step.**
- 4) Start engine and run it for 65 minutes at idle speed.  
**If engine coolant temperature increases to more than 10°C (50°F) within 65 minutes, stop engine because the test result will be OK.**
- 5) Select "MODE 7" with GST.
- 6) If 1st trip DTC is detected, go to "Diagnostic Procedure", EC-164.

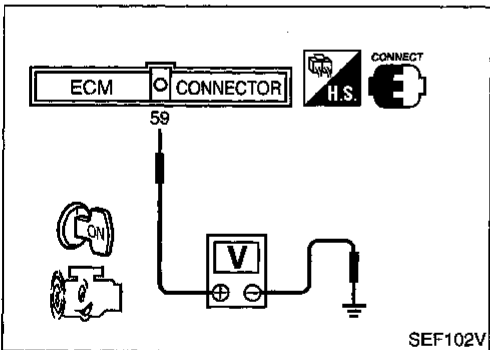
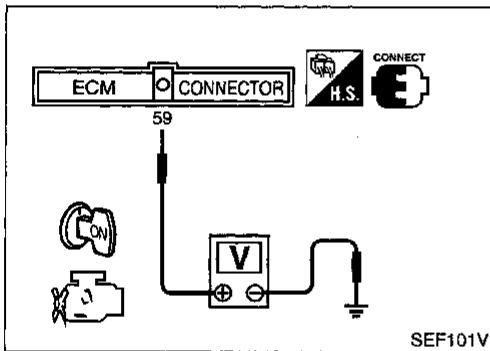

### No Tools

- 1) Turn ignition switch "ON".
- 2) Check that voltage between ECM terminal 59 (Engine coolant temperature sensor signal) and ground is less than 3.8V.  
**If it is less than 3.8V, the test result will be OK.**  
**If it is over 3.8V, go to following step.**
- 3) Start engine and run it for 65 minutes at idle speed measuring voltage between ECM terminal 59 and ground.  
**If the voltage decreases to less than 3.8V within 65 minutes, stop engine because the test result will be OK.**
- 4) Turn ignition switch "OFF", wait at least 5 seconds and then turn "ON".
- 5) Perform "Diagnostic Test Mode II (Self-diagnostic results)" with ECM.
- 6) If 1st trip DTC is detected, go to "Diagnostic Procedure", EC-164.



# DTC P0125 ENGINE COOLANT TEMPERATURE (ECT) SENSOR

Wiring Diagram

## Wiring Diagram

NEEC0084

EC-ECTS-01

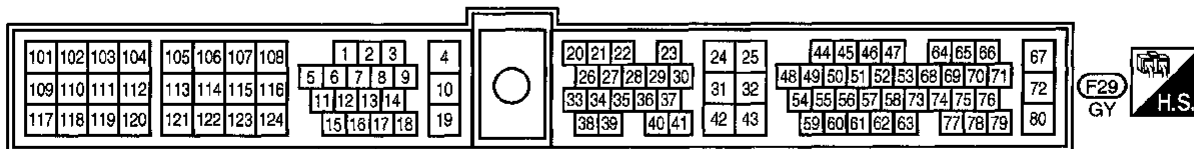
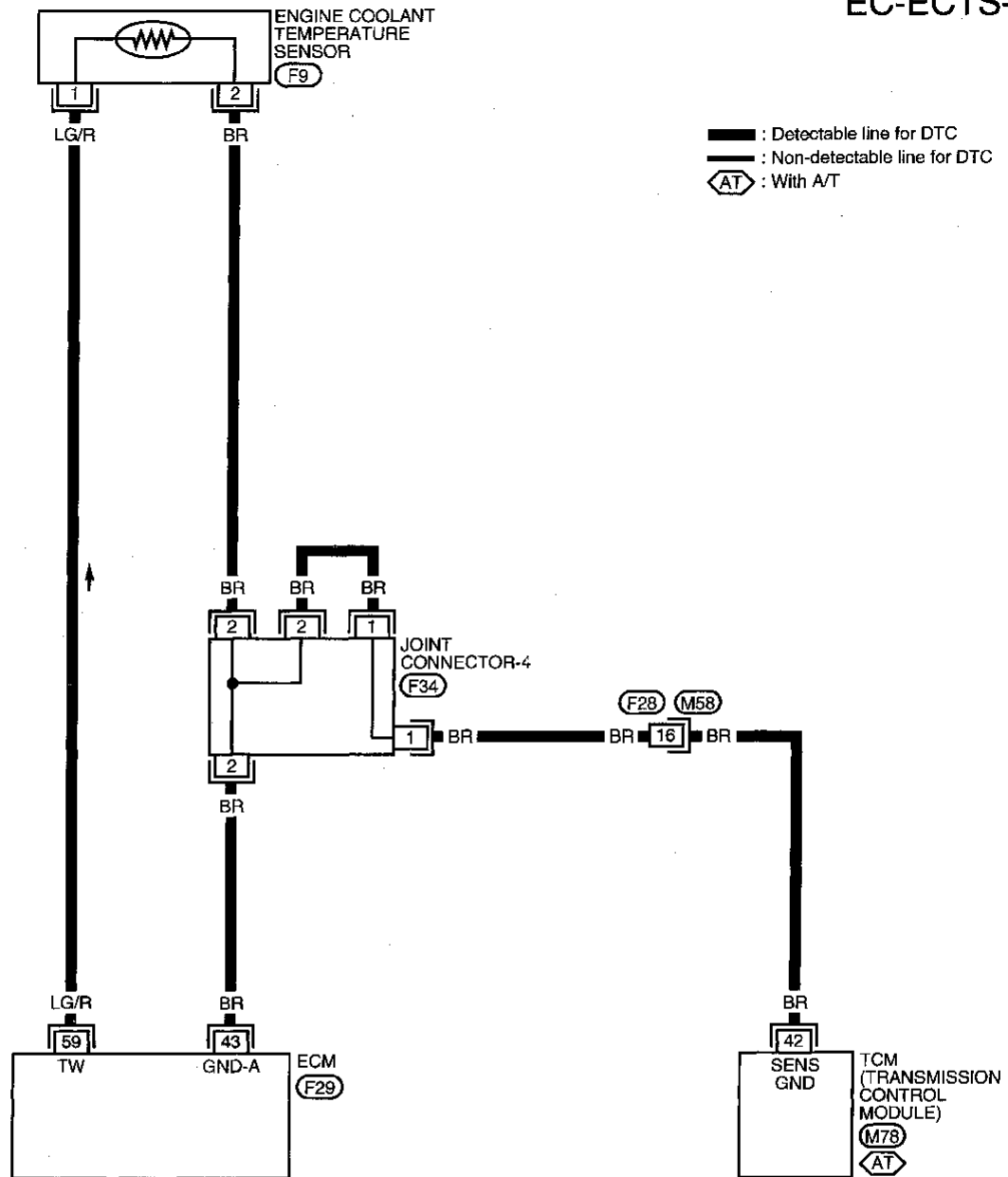

AEC756A

# DTC P0125 ENGINE COOLANT TEMPERATURE (ECT) SENSOR

Diagnostic Procedure

## Diagnostic Procedure

NEEC0085

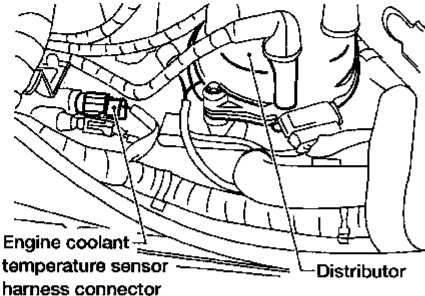
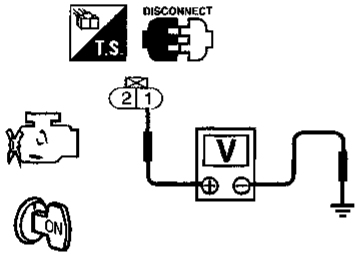
<b>1</b>	<b>CHECK POWER SUPPLY</b>
<p>1. Turn ignition switch "OFF".                  2. Disconnect engine coolant temperature sensor harness connector.</p>  <p style="text-align: center;">Engine coolant temperature sensor harness connector      Distributor</p> <p style="text-align: right;">AEC643A</p> <p>3. Turn ignition switch "ON".                  4. Check voltage between terminal 1 and ground with CONSULT or tester.</p>  <p style="text-align: center;">Voltage: Approximately 5V</p> <p style="text-align: right;">SEF206W</p>	
<b>OK or NG</b>	
OK	▶ GO TO 2.
NG	▶ Repair open circuit or short to ground or short to power in harness or connectors.

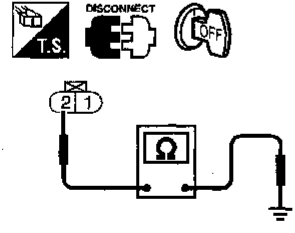
<b>2</b>	<b>CHECK GROUND CIRCUIT</b>
<p>1. Turn ignition switch "OFF".                  2. Check harness continuity between terminal 2 and engine ground.</p>  <p style="text-align: right;">SEF207W</p> <p style="text-align: center;"><b>Continuity should exist.</b></p> <p>3. Also check harness for short to ground and short to power.</p> <p style="text-align: center;"><b>OK or NG</b></p>	
OK	▶ GO TO 4.
NG	▶ GO TO 3.

<b>3</b>	<b>DETECT MALFUNCTIONING PART</b>
<p>Check the following.</p> <ul style="list-style-type: none"> <li>• Harness connectors F28, M58</li> <li>• Joint connector-4</li> <li>• Harness for open or short between ECM and engine coolant temperature sensor</li> <li>• Harness for open or short between TCM (Transmission Control Module) and engine coolant temperature sensor</li> </ul>	
▶	Repair open circuit or short to ground or short to power in harness or connectors.

<b>4</b>	<b>CHECK ENGINE COOLANT TEMPERATURE SENSOR</b>
Refer to "Component Inspection", EC-165.	
<b>OK or NG</b>	
OK	▶ GO TO 5.
NG	▶ Replace engine coolant temperature sensor.

<b>5</b>	<b>CHECK THERMOSTAT OPERATION</b>
When the engine is cold [lower than 70°C (158°F)] condition, grasp lower radiator hose and confirm the engine coolant does not flow.	
<b>OK or NG</b>	
OK	▶ GO TO 6.
NG	▶ Repair or replace thermostat. Refer to LC section ("Thermostat", "ENGINE COOLING SYSTEM").

<b>6</b>	<b>CHECK INTERMITTENT INCIDENT</b>
Refer to "TROUBLE DIAGNOSIS FOR INTERMITTENT INCIDENT", EC-115.	
▶	<b>INSPECTION END</b>

# DTC P0125 ENGINE COOLANT TEMPERATURE (ECT) SENSOR

Component Inspection

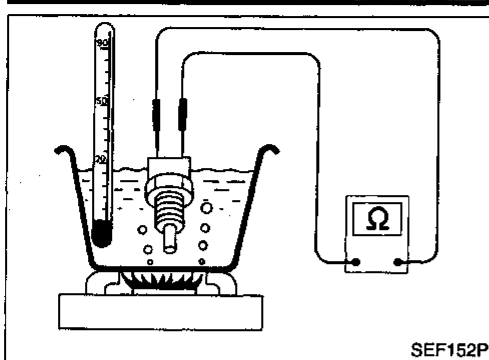

SEF152P

## Component Inspection

### ENGINE COOLANT TEMPERATURE SENSOR

NEEC0086

NEEC0086S01

Check resistance as shown in the figure.

#### <Reference data>

Temperature °C (°F)	Resistance kΩ
20 (68)	2.1 - 2.9
50 (122)	0.68 - 1.0
90 (194)	0.236 - 0.260

If NG, replace engine coolant temperature sensor.

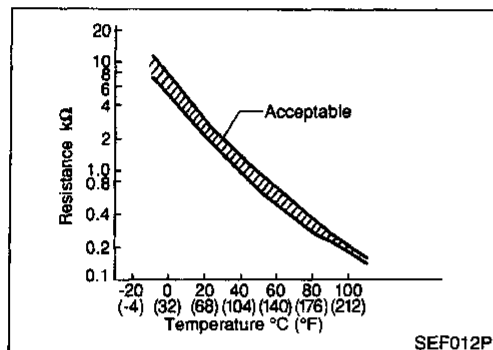

SEF012P

GI  
MA  
EM  
LC  
EC  
FE  
CL  
MT  
AT  
TF  
PD  
FA  
RA  
BR  
ST  
RS  
BT  
HA  
EL  
IDX

# DTC P0130 (RIGHT BANK, -B1), P0150 (LEFT BANK, -B2) FRONT HEATED OXYGEN SENSOR (FRONT HO2S) (CIRCUIT)

## Component Description

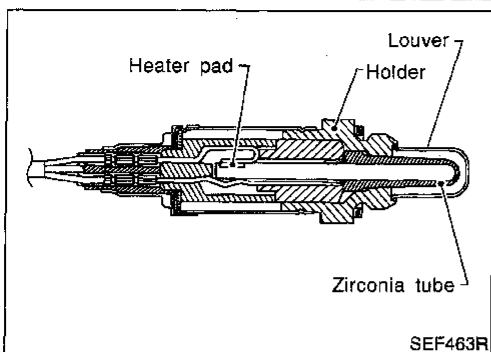

## Component Description

The front heated oxygen sensor is placed into the front tube. It detects the amount of oxygen in the exhaust gas compared to the outside air. The front heated oxygen sensor has a closed-end tube made of ceramic zirconia. The zirconia generates voltage from approximately 1V in richer conditions to 0V in leaner conditions. The front heated oxygen sensor signal is sent to the ECM. The ECM adjusts the injection pulse duration to achieve the ideal air-fuel ratio. The ideal air-fuel ratio occurs near the radical change from 1V to 0V.

NEEC0090

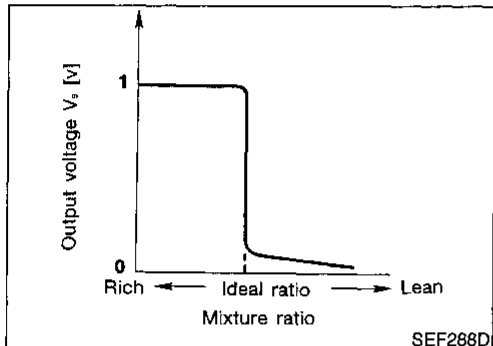

## CONSULT Reference Value in Data Monitor Mode

NEEC0091

Specification data are reference values.

MONITOR ITEM	CONDITION		SPECIFICATION
FR O2 SEN-B1 FR O2 SEN-B2	<ul style="list-style-type: none"> <li>Engine: After warming up</li> </ul>	Maintaining engine speed at 2,000 rpm	0 - 0.3V ↔ Approx. 0.6 - 1.0V
FR O2 MNTR-B1 FR O2 MNTR-B2			LEAN ↔ RICH Changes more than 5 times during 10 seconds.

## ECM Terminals and Reference Value

NEEC0092

Specification data are reference values and are measured between each terminal and 32 (ECM ground).

TERMI- NAL NO.	WIRE COLOR	ITEM	CONDITION	DATA (DC Voltage)
50	B	Front heated oxygen sensor RH	<b>[Engine is running]</b> <ul style="list-style-type: none"> <li>After warming up to normal operating temperature and engine speed is 2,000 rpm</li> </ul>	0 - Approximately 1.0V
51	G	Front heated oxygen sensor LH		

SEF002V

# DTC P0130 (RIGHT BANK, -B1), P0150 (LEFT BANK, -B2) FRONT HEATED OXYGEN SENSOR (FRONT HO2S) (CIRCUIT)

On Board Diagnosis Logic

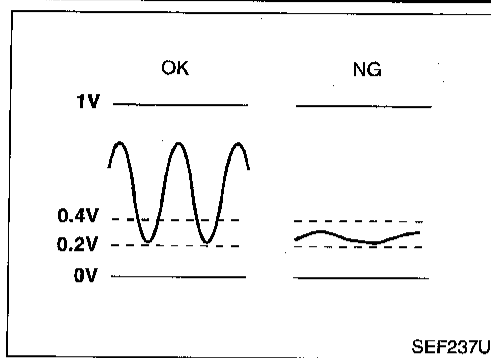

## On Board Diagnosis Logic

NEEC0093

Under the condition in which the front heated oxygen sensor signal is not input, the ECM circuits will read a continuous approximately 0.3V. Therefore, for this diagnosis, the time that output voltage is within 200 to 400 mV range is monitored, and the diagnosis checks that this time is not inordinately long.

DTC No.	Malfunction is detected when ...	Check Items (Possible Cause)
P0130 0503 (Right bank)	<ul style="list-style-type: none"> <li>The voltage from the sensor is constantly approx. 0.3V.</li> </ul>	<ul style="list-style-type: none"> <li>Harness or connectors (The sensor circuit is open or shorted.)</li> <li>Front heated oxygen sensor</li> </ul>
P0150 0303 (Left bank)		

5

FR O2 SEN-B1 P0130

OUT OF CONDITION

===== MONITOR =====

CMPS-RPM(POS) 1300rpm  
THRRTL POS SEN 0.72V  
B/FUEL SCHDL 2.9msec

FR O2 SEN-B2 P0150

OUT OF CONDITION

===== MONITOR =====

CMPS-RPM(POS) 1300rpm  
THRRTL POS SEN 0.72V  
B/FUEL SCHDL 2.9msec

SEF694W

5

FR O2 SEN-B1 P0130

TESTING

===== MONITOR =====

CMPS-RPM(POS) 1892rpm  
THRRTL POS SEN 0.90V  
B/FUEL SCHDL 3.5msec

FR O2 SEN-B2 P0150

TESTING

===== MONITOR =====

CMPS-RPM(POS) 1892rpm  
THRRTL POS SEN 0.90V  
B/FUEL SCHDL 3.5msec

SEF695W

5

FR O2 SEN-B1 P0130

COMPLETED

SELF-DIAG RESULTS

FR O2 SEN-B2 P0150

COMPLETED

SELF-DIAG RESULTS

SEF526UB

## DTC Confirmation Procedure

NEEC0390

### CAUTION:

Always drive vehicle at a safe speed.

### NOTE:

If "DTC Confirmation Procedure" has been previously conducted, always turn ignition switch "OFF" and wait at least 5 seconds before conducting the next test.

### TESTING CONDITION:

Before performing the following procedure, confirm that battery voltage is more than 11V at idle.

### With CONSULT

- Start engine and warm it up to normal operating temperature.
- Select "FR O2 SEN-B1 (-B2) P0130 (P0150)" of "FRONT O2 SENSOR" in "DTC WORK SUPPORT" mode with CONSULT.
- Touch "START".
- Let it idle for at least 3.5 minutes.

### NOTE:

Never raise engine speed above 3,200 rpm after this step. If the engine speed limit is exceeded, return to step 4.

- When the following conditions are met, "TESTING" will be displayed on the CONSULT screen. Maintain the conditions continuously until "TESTING" changes to "COMPLETED". (It will take approximately 10 to 60 seconds.)

CMPS-RPM (POS)	1,500 - 2,650 rpm
Vehicle speed	70 - 120 km/h (43 - 75 MPH)
B/FUEL SCHDL	1.4 - 6.5 msec
Selector lever	Suitable position

If "TESTING" is not displayed after 5 minutes, retry from step 2.

- Make sure that "OK" is displayed after touching "SELF-DIAG

# DTC P0130 (RIGHT BANK, -B1), P0150 (LEFT BANK, -B2) FRONT HEATED OXYGEN SENSOR (FRONT HO2S) (CIRCUIT)

DTC Confirmation Procedure (Cont'd)

**RESULTS**. If "NG" is displayed, refer to "Diagnostic Procedure", EC-171.

During this test, P1148 and P1168 may be stored in ECM.

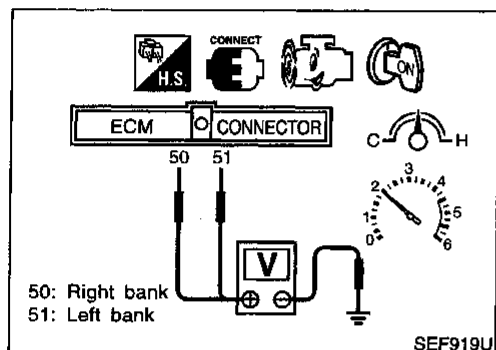

## Overall Function Check

NEEC0084

Use this procedure to check the overall function of the front heated oxygen sensor circuit. During this check, a 1st trip DTC might not be confirmed.

### ⊗ Without CONSULT

- 1) Start engine and warm it up to normal operating temperature.
- 2) Set voltmeter probes between ECM terminal 50 (right bank sensor signal) or 51 (left bank sensor signal) and engine ground.
- 3) Check the following with engine speed held at 2,000 rpm constant under no load.
  - The voltage does not remain in the range of 0.2 - 0.4V.
- 4) If NG, go to "Diagnostic Procedure", EC-171.

# DTC P0130 (RIGHT BANK, -B1), P0150 (LEFT BANK, -B2) FRONT HEATED OXYGEN SENSOR (FRONT HO2S) (CIRCUIT)

Wiring Diagram

## Wiring Diagram

RIGHT BANK

NEEC0095

NEEC0095S01

EC-FRO2RH-01

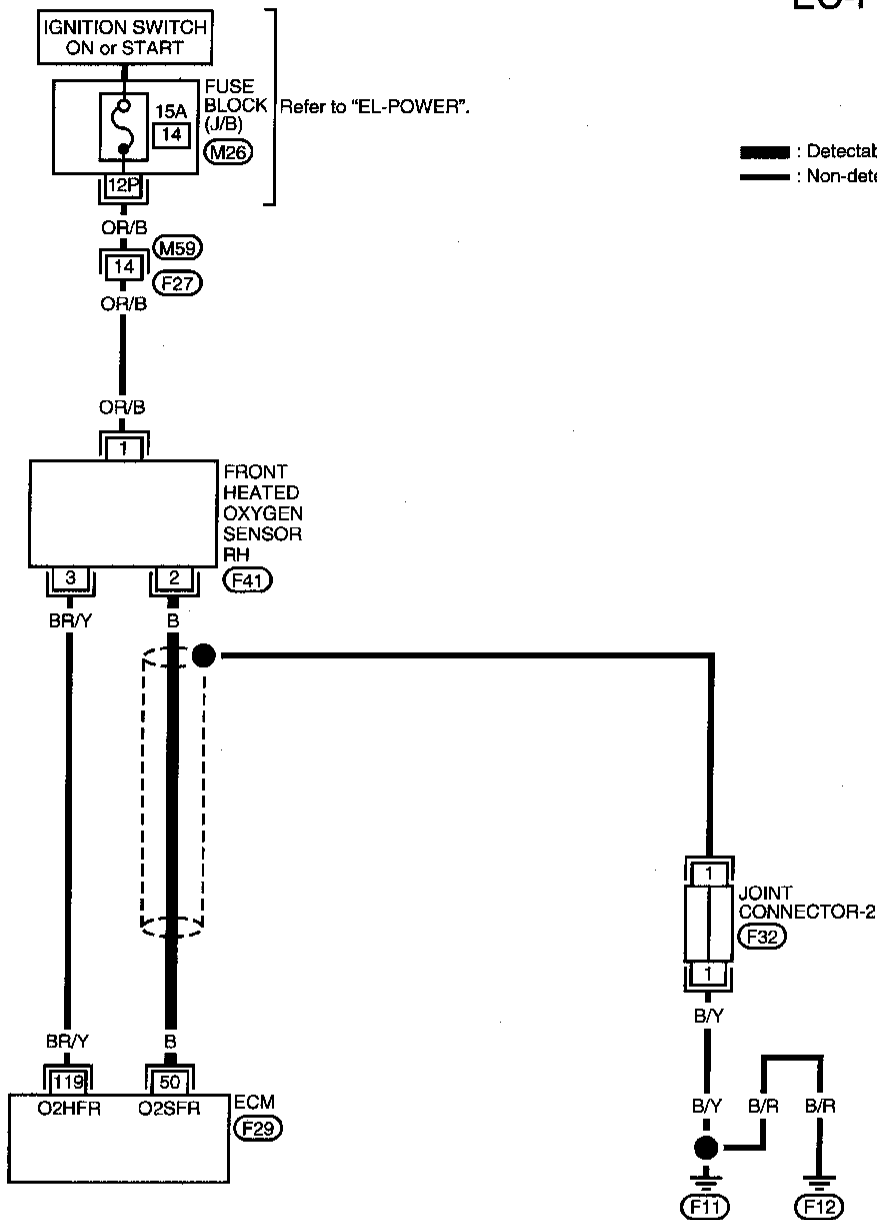

— : Detectable line for DTC  
 — : Non-detectable line for DTC

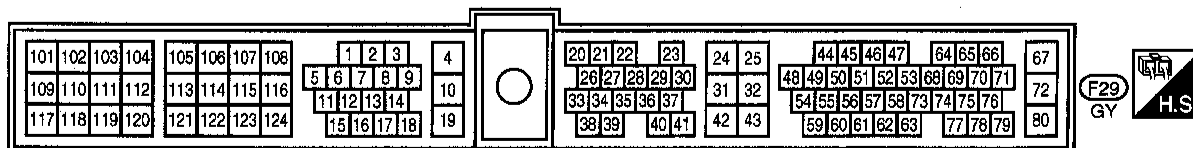
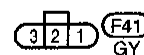
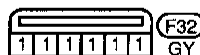
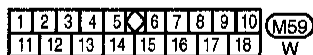

AEC729A

GI  
 MA  
 EM  
 LC  
**EC**  
 FE  
 CL  
 MT  
 AT  
 TF  
 PD  
 FA  
 RA  
 BR  
 ST  
 RS  
 BT  
 HA  
 EL  
 IDX

# DTC P0130 (RIGHT BANK, -B1), P0150 (LEFT BANK, -B2) FRONT HEATED OXYGEN SENSOR (FRONT HO2S) (CIRCUIT)

Wiring Diagram (Cont'd)

## LEFT BANK

NEEC0095302

### EC-FRO2LH-01

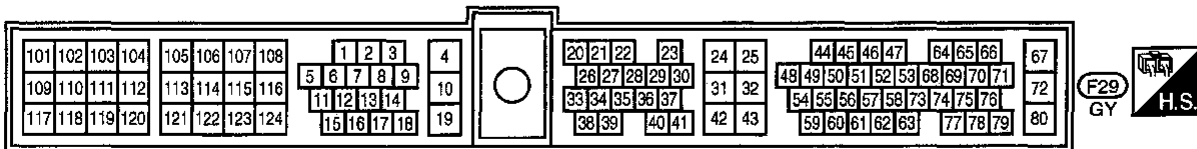
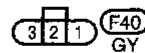
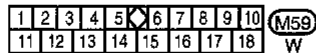
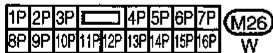
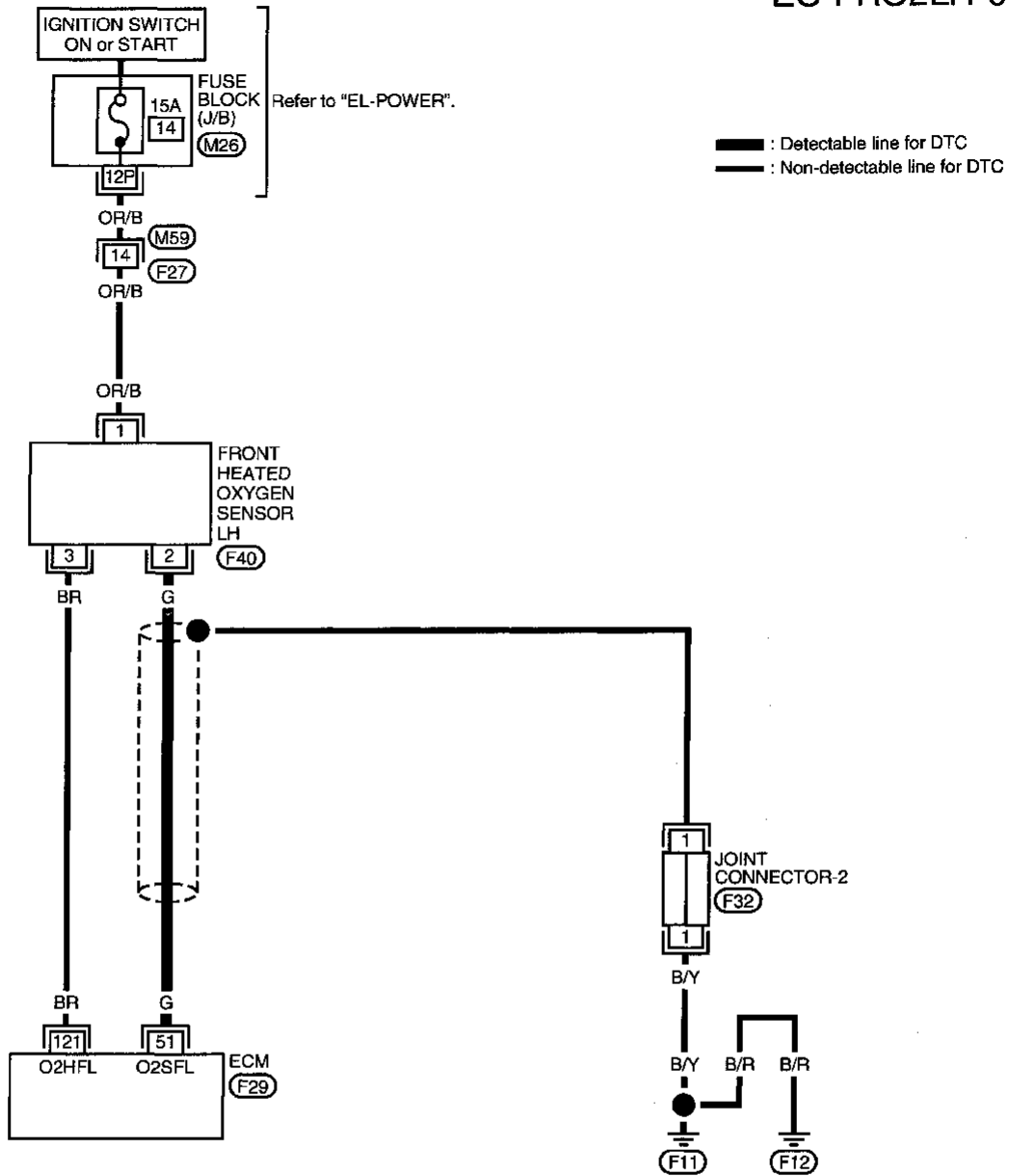

AEC730A



# DTC P0130 (RIGHT BANK, -B1), P0150 (LEFT BANK, -B2) FRONT HEATED OXYGEN SENSOR (FRONT HO2S) (CIRCUIT)

Diagnostic Procedure

NEEC0096

## Diagnostic Procedure

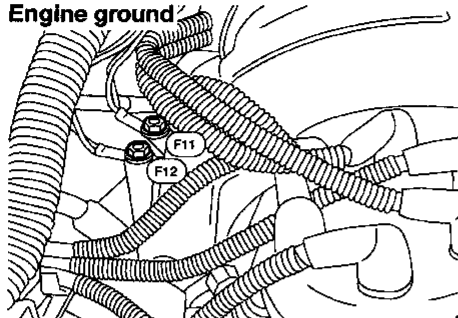
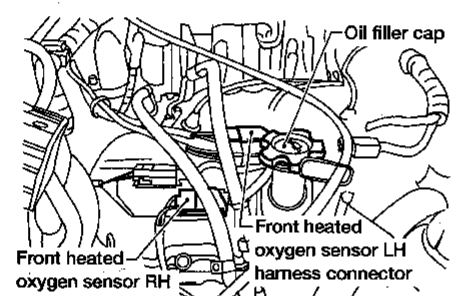
<b>1</b>	<b>INSPECTION START</b>
<ol style="list-style-type: none"> <li>Turn ignition switch "OFF".</li> <li>Loosen and retighten engine ground screws.</li> </ol>	
<p><b>Engine ground</b></p>  <p style="text-align: right;">AEC640A</p>	
<ol style="list-style-type: none"> <li>Make sure front HO2S harness protector color, and disconnect corresponding front heated oxygen sensor harness connector.</li> </ol>	
 <p style="text-align: right;">AEC644A</p>	
<p>▶ GO TO 2.</p>	

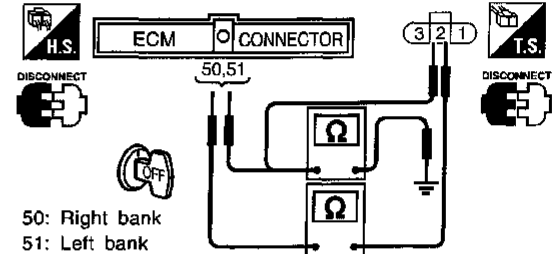
<b>2</b>	<b>CHECK INPUT SIGNAL CIRCUIT</b>														
<ol style="list-style-type: none"> <li>Disconnect ECM harness connector.</li> <li>Check harness continuity between ECM terminal and sensor terminal as follows.</li> </ol>															
<table border="1" style="width: 100%;"> <thead> <tr> <th rowspan="2">DTC</th> <th colspan="2">Terminals</th> <th rowspan="2">Bank</th> </tr> <tr> <th>ECM</th> <th>Sensor</th> </tr> </thead> <tbody> <tr> <td>P0130</td> <td>50</td> <td>2</td> <td>Right</td> </tr> <tr> <td>P0150</td> <td>51</td> <td>2</td> <td>Left</td> </tr> </tbody> </table> <p style="text-align: right;">AEC888A</p>		DTC	Terminals		Bank	ECM	Sensor	P0130	50	2	Right	P0150	51	2	Left
DTC	Terminals		Bank												
	ECM	Sensor													
P0130	50	2	Right												
P0150	51	2	Left												
 <p style="text-align: right;">SEF632W</p>															
<p>50: Right bank 51: Left bank</p> <p style="text-align: center;"><b>Continuity should exist.</b></p>															
<ol style="list-style-type: none"> <li>Check harness continuity between ECM terminal or sensor terminal and ground as follows.</li> </ol>															
<table border="1" style="width: 100%;"> <thead> <tr> <th rowspan="2">DTC</th> <th colspan="2">Terminals</th> <th rowspan="2">Bank</th> </tr> <tr> <th>ECM or sensor</th> <th>Ground</th> </tr> </thead> <tbody> <tr> <td>P0130</td> <td>50 or 2</td> <td>Ground</td> <td>Right</td> </tr> <tr> <td>P0150</td> <td>51 or 2</td> <td>Ground</td> <td>Left</td> </tr> </tbody> </table> <p style="text-align: right;">AEC889A</p>		DTC	Terminals		Bank	ECM or sensor	Ground	P0130	50 or 2	Ground	Right	P0150	51 or 2	Ground	Left
DTC	Terminals		Bank												
	ECM or sensor	Ground													
P0130	50 or 2	Ground	Right												
P0150	51 or 2	Ground	Left												
<p style="text-align: center;"><b>Continuity should not exist.</b></p>															
<ol style="list-style-type: none"> <li>Also check harness for short to power.</li> </ol>															
<p><b>OK or NG</b></p>															
OK	▶	GO TO 3.													
NG	▶	Repair open circuit or short to ground or short to power in harness or connectors.													

<b>3</b>	<b>CHECK FRONT HEATED OXYGEN SENSOR</b>	
<p>Refer to "Component Inspection", EC-172.</p> <p style="text-align: center;"><b>OK or NG</b></p>		
OK	▶	GO TO 4.
NG	▶	Replace malfunctioning front heated oxygen sensor.

GI  
MA  
EM  
LC  
EC  
FE  
CL  
MT  
AT  
TF  
PD  
FA  
RA  
BR  
ST  
RS  
BT  
HA  
EL  
IDX

# DTC P0130 (RIGHT BANK, -B1), P0150 (LEFT BANK, -B2) FRONT HEATED OXYGEN SENSOR (FRONT HO2S) (CIRCUIT)

Diagnostic Procedure (Cont'd)

<b>4</b>	<b>CHECK SHIELD CIRCUIT</b>
1. Turn ignition switch "OFF". 2. Disconnect joint connector-2. 3. Check the following. <ul style="list-style-type: none"> <li>• Continuity between joint connector terminal and ground</li> <li>• Joint connector (Refer to "HARNES LAYOUT" in EL section.)</li> </ul> <b>Continuity should exist.</b>	
4. Also check harness for short to ground and short to power. 5. Then reconnect joint connector-2.	
<b>OK or NG</b>	
OK	▶ GO TO 5.
NG	▶ Repair open circuit or short to ground or short to power in harness or connectors.

<b>5</b>	<b>CHECK INTERMITTENT INCIDENT</b>
Refer to "TROUBLE DIAGNOSIS FOR INTERMITTENT INCIDENT", EC-115.	
▶	<b>INSPECTION END</b>

☆ MONITOR    ☆ NO FAIL <input type="checkbox"/>
CMPS-RPM(REF)    2137rpm MAS AIR/FL SE    1.96V COOLAN TEMP/S    84°C FR O2 SEN-B1    0.37V FR O2 MNTR-B1    LEAN INJ PULSE-B1    2.6msec A/F ALPHA-B1    101% FR O2 HTR-B1    ON
<b>RECORD</b>

SEF365V

Right bank cycle      1   2   3   4   5   FR O2 MNTR-B1 R-L-R-L-R-L-R-L-R-L-R
Left bank cycle      1   2   3   4   5   FR O2 MNTR-B2 R-L-R-L-R-L-R-L-R-L-R
R means FR O2 MNTR-B1(-B2) indicates RICH L means FR O2 MNTR-B1(-B2) indicates LEAN

SEF702W

## Component Inspection FRONT HEATED OXYGEN SENSOR

NEEC0391

NEEC0391S01

### Ⓢ With CONSULT

- 1) Start engine and warm it up to normal operating temperature.
- 2) Select "MANU TRIG" and "HI SPEED" in "DATA MONITOR" mode with CONSULT, and select "FR O2 SEN-B1 (-B2)" and "FR O2 MNTR-B1 (-B2)".
- 3) Hold engine speed at 2,000 rpm under no load during the following steps.
- 4) Touch "RECORD" on CONSULT screen.
- 5) Check the following.
  - "FR O2 MNTR-B1 (-B2)" in "DATA MONITOR" mode changes from "RICH" to "LEAN" to "RICH" 5 times in 10 seconds. 5 times (cycles) are counted as shown left:
  - "FR O2 SEN-B1 (-B2)" voltage goes above 0.6V at least once.
  - "FR O2 SEN-B1 (-B2)" voltage goes below 0.3V at least once.
  - "FR O2 SEN-B1 (-B2)" voltage never exceeds 1.0V.

### CAUTION:

**Discard any heated oxygen sensor which has been dropped from a height of more than 0.5 m (19.7 in) onto a hard surface such as a concrete floor; use a new one.**

# DTC P0130 (RIGHT BANK, -B1), P0150 (LEFT BANK, -B2) FRONT HEATED OXYGEN SENSOR (FRONT HO2S) (CIRCUIT)

Component Inspection (Cont'd)

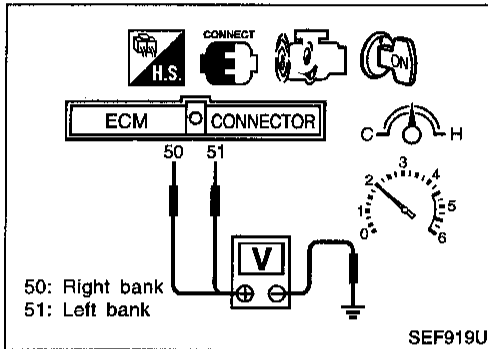
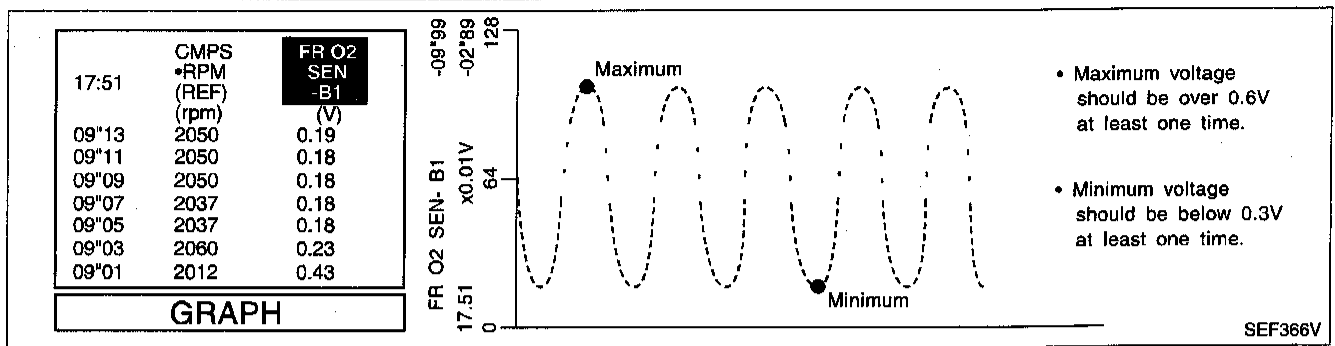

## ⊗ Without CONSULT

- 1) Start engine and warm it up to normal operating temperature.
- 2) Set voltmeter probes between ECM terminal 50 (right bank sensor signal) or 51 (left bank sensor signal) and engine ground.
- 3) Check the following with engine speed held at 2,000 rpm constant under no load.
  - MIL goes on more than 5 times within 10 seconds in Diagnostic Test Mode II (FRONT HEATED OXYGEN SENSOR MONITOR).
  - The maximum voltage is over 0.6V at least one time.
  - The minimum voltage is below 0.3V at least one time.
  - The voltage never exceeds 1.0V.

### CAUTION:

Discard any heated oxygen sensor which has been dropped from a height of more than 0.5 m (19.7 in) onto a hard surface such as a concrete floor; use a new one.

GI  
MA  
EM  
LC  
EC  
FE  
CL  
MT  
AT  
TF  
PD  
FA  
RA  
BR  
ST  
RS  
BT  
HA  
EL  
IDX

# DTC P0131 (RIGHT BANK, -B1), P0151 (LEFT BANK, -B2) FRONT HEATED OXYGEN SENSOR (FRONT HO2S) (LEAN SHIFT MONITORING)

## Component Description

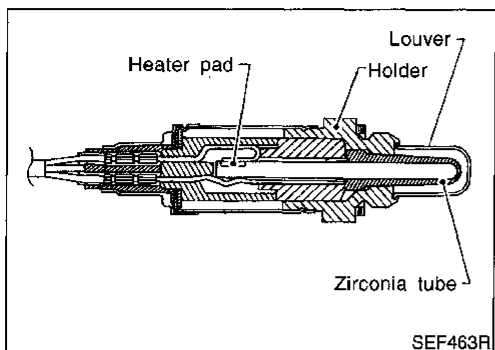

## Component Description

The front heated oxygen sensor is placed into the front tube. It detects the amount of oxygen in the exhaust gas compared to the outside air. The front heated oxygen sensor has a closed-end tube made of ceramic zirconia. The zirconia generates voltage from approximately 1V in richer conditions to 0V in leaner conditions. The front heated oxygen sensor signal is sent to the ECM. The ECM adjusts the injection pulse duration to achieve the ideal air-fuel ratio. The ideal air-fuel ratio occurs near the radical change from 1V to 0V.

NEEC0392

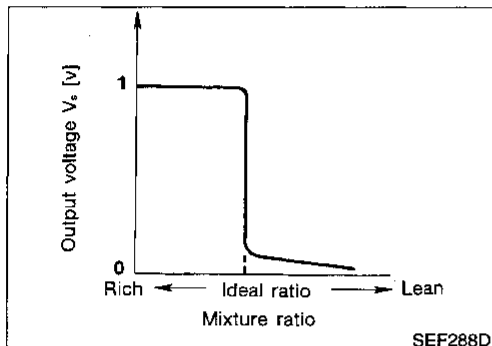

## CONSULT Reference Value in Data Monitor Mode

NEEC0393

Specification data are reference values.

MONITOR ITEM	CONDITION	SPECIFICATION
FR O2 SEN-B1 FR O2 SEN-B2	<ul style="list-style-type: none"> <li>Engine: After warming up</li> </ul> Maintaining engine speed at 2,000 rpm	0 - 0.3V ↔ Approx. 0.6 - 1.0V
FR O2 MNTR-B1 FR O2 MNTR-B2		LEAN ↔ RICH Changes more than 5 times during 10 seconds.

## ECM Terminals and Reference Value

NEEC0394

Specification data are reference values and are measured between each terminal and 32 (ECM ground).

TERMI-NAL NO.	WIRE COLOR	ITEM	CONDITION	DATA (DC Voltage)
50	B	Front heated oxygen sensor RH	<b>[Engine is running]</b> <ul style="list-style-type: none"> <li>After warming up to normal operating temperature and engine speed is 2,000 rpm</li> </ul>	0 - Approximately 1.0V 
51	G	Front heated oxygen sensor LH		SEF002V

# DTC P0131 (RIGHT BANK, -B1), P0151 (LEFT BANK, -B2) FRONT HEATED OXYGEN SENSOR (FRONT HO2S) (LEAN SHIFT MONITORING)

On Board Diagnosis Logic

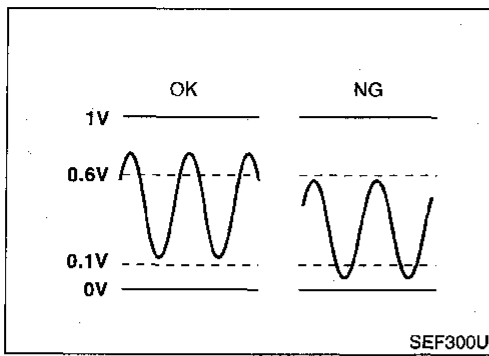

## On Board Diagnosis Logic

NEEC0385

To judge the malfunction, the output from the front heated oxygen sensor is monitored to determine whether the "rich" output is sufficiently high and whether the "lean" output is sufficiently low. When both the outputs are shifting to the lean side, the malfunction will be detected.

DTC No.	Malfunction is detected when ...	Check Items (Possible Cause)
P0131 0415 (Right bank)	<ul style="list-style-type: none"> <li>The maximum and minimum voltage from the sensor are not reached to the specified voltages.</li> </ul>	<ul style="list-style-type: none"> <li>Front heated oxygen sensor</li> <li>Front heated oxygen sensor heater</li> <li>Fuel pressure</li> <li>Injectors</li> <li>Intake air leaks</li> </ul>
P0151 0411 (Left bank)		

## DTC Confirmation Procedure

NEEC0396

### CAUTION:

Always drive vehicle at a safe speed.

### NOTE:

If "DTC Confirmation Procedure" has been previously conducted, always turn ignition switch "OFF" and wait at least 5 seconds before conducting the next test.

### TESTING CONDITION:

- Always perform at a temperature above  $-10^{\circ}\text{C}$  ( $14^{\circ}\text{F}$ ).
- Before performing following procedure, confirm that battery voltage is more than 11V at idle.

CI  
MA  
EM  
LC  
EC  
FE  
CL  
MT  
AT  
TF  
PD  
FA  
RA  
BR  
ST  
RS  
BT  
HA  
EL  
IDX

# DTC P0131 (RIGHT BANK, -B1), P0151 (LEFT BANK, -B2) FRONT HEATED OXYGEN SENSOR (FRONT HO2S) (LEAN SHIFT MONITORING)

DTC Confirmation Procedure (Cont'd)

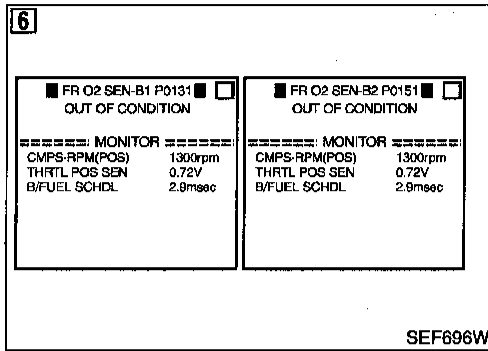

## Ⓜ With CONSULT

- 1) Start engine and warm it up to normal operating temperature.
- 2) Stop engine and wait at least 5 seconds.
- 3) Turn ignition switch "ON" and select "FR O2 SEN-B1 (-B2) P0131 (P0151)" of "FRONT O2 SENSOR" in "DTC WORK SUPPORT" mode with CONSULT.
- 4) Touch "START".
- 5) Start engine and let it idle for at least 3.5 minutes.

### NOTE:

Never raise engine speed above 3,200 rpm after this step. If the engine speed limit is exceeded, return to step 5.

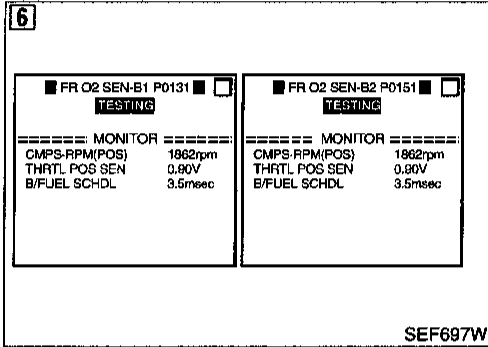

- 6) When the following conditions are met, "TESTING" will be displayed on the CONSULT screen. Maintain the conditions continuously until "TESTING" changes to "COMPLETED". (It will take approximately 50 seconds or more.)

CMPS-RPM (POS)	1,800 - 2,800 rpm
Vehicle speed	80 - 100 km/h (50 - 62 MPH)
B/FUEL SCHDL	1.7 - 6.5 msec
Selector lever	Suitable position

If "TESTING" is not displayed after 5 minutes, retry from step 2.

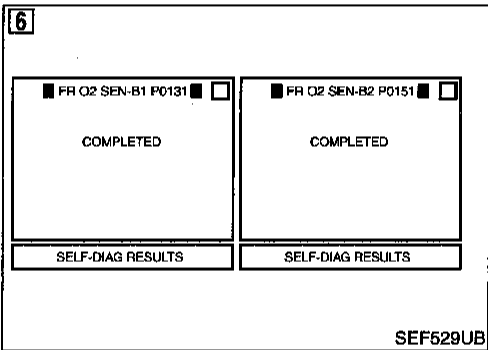

- 7) Make sure that "OK" is displayed after touching "SELF-DIAG RESULTS". If "NG" is displayed, refer to "Diagnostic Procedure", EC-177.

## Overall Function Check

NEEC0397

Use this procedure to check the overall function of the front heated oxygen sensor circuit. During this check, a 1st trip DTC might not be confirmed.

### Ⓜ Without CONSULT

- 1) Start engine and warm it up to normal operating temperature.
- 2) Set voltmeter probes between ECM terminal 50 (right bank sensor signal) or 51 (left bank sensor signal) and engine ground.
- 3) Check one of the following with engine speed held at 2,000 rpm constant under no load.
  - The maximum voltage is over 0.6V at least one time.
  - The minimum voltage is over 0.1V at least one time.
- 4) If NG, go to "Diagnostic Procedure", EC-177.

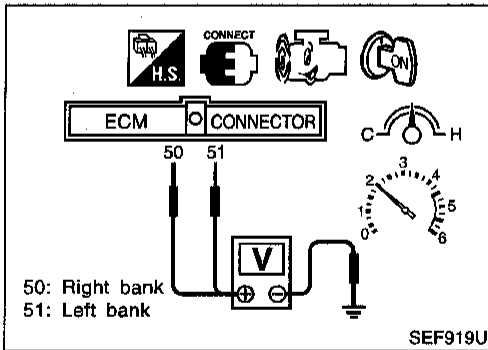

# DTC P0131 (RIGHT BANK, -B1), P0151 (LEFT BANK, -B2) FRONT HEATED OXYGEN SENSOR (FRONT HO2S) (LEAN SHIFT MONITORING)

Diagnostic Procedure

## Diagnostic Procedure

NEEC0399

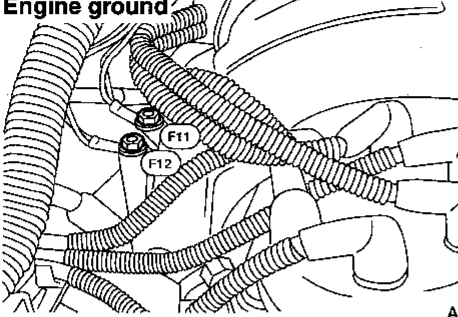
<b>1</b>	<b>RETIGHTEN GROUND SCREWS</b>
<ol style="list-style-type: none"> <li>Turn ignition switch "OFF".</li> <li>Loosen and retighten engine ground screws.</li> </ol>	
<p><b>Engine ground</b></p>  <p style="text-align: right;">AEC640A</p>	
▶ GO TO 2.	

<b>2</b>	<b>RETIGHTEN FRONT HEATED OXYGEN SENSOR</b>
Loosen and retighten corresponding front heated oxygen sensor.	
<p><b>Tightening torque:</b> 40 - 50 N·m (4.1 - 5.1 kg-m, 30 - 37 ft-lb)</p>	
▶ GO TO 3.	

<b>3</b>	<b>CLEAR THE SELF-LEARNING DATA</b>																				
<p><b>With CONSULT</b></p> <ol style="list-style-type: none"> <li>Start engine and warm it up to normal operating temperature.</li> <li>Select "SELF-LEARNING CONT" in "ACTIVE TEST" mode with CONSULT.</li> <li>Clear the self-learning control coefficient by touching "CLEAR".</li> </ol>																					
<table border="1" style="width: 100%;"> <tr> <td colspan="2" style="text-align: center;"><b>ACTIVE TEST</b></td> </tr> <tr> <td>SELF-LEARN CONTROL</td> <td>B1 : 100% B2 : 100%</td> </tr> <tr> <td colspan="2" style="text-align: center;">----- MONITOR -----</td> </tr> <tr> <td>CMPS*RPM(REF)</td> <td>750rpm</td> </tr> <tr> <td>COOLAN TEMP/S</td> <td>93°C</td> </tr> <tr> <td>FR O2 SEN-B1</td> <td>0.90V</td> </tr> <tr> <td>FR O2 SEN-B2</td> <td>0.90V</td> </tr> <tr> <td>A/F ALPHA-B1</td> <td>100%</td> </tr> <tr> <td>A/F ALPHA-B2</td> <td>100%</td> </tr> <tr> <td colspan="2" style="text-align: center;"><b>CLEAR</b></td> </tr> </table>		<b>ACTIVE TEST</b>		SELF-LEARN CONTROL	B1 : 100% B2 : 100%	----- MONITOR -----		CMPS*RPM(REF)	750rpm	COOLAN TEMP/S	93°C	FR O2 SEN-B1	0.90V	FR O2 SEN-B2	0.90V	A/F ALPHA-B1	100%	A/F ALPHA-B2	100%	<b>CLEAR</b>	
<b>ACTIVE TEST</b>																					
SELF-LEARN CONTROL	B1 : 100% B2 : 100%																				
----- MONITOR -----																					
CMPS*RPM(REF)	750rpm																				
COOLAN TEMP/S	93°C																				
FR O2 SEN-B1	0.90V																				
FR O2 SEN-B2	0.90V																				
A/F ALPHA-B1	100%																				
A/F ALPHA-B2	100%																				
<b>CLEAR</b>																					
SEF921U																					
<ol style="list-style-type: none"> <li>Run engine for at least 10 minutes at idle speed. <b>Is the 1st trip DTC P0171 or P0174 detected? Is it difficult to start engine?</b></li> </ol>																					
<p><b>Without CONSULT</b></p> <ol style="list-style-type: none"> <li>Start engine and warm it up to normal operating temperature.</li> <li>Turn ignition switch "OFF".</li> <li>Disconnect mass air flow sensor harness connector, and restart and run engine for at least 5 seconds at idle speed.</li> <li>Stop engine and reconnect mass air flow sensor harness connector.</li> <li>Make sure 1st trip DTC No. 0102 is displayed in Diagnostic Test Mode II.</li> <li>Erase the diagnostic test mode II (Self-diagnostic results) memory. Refer to "HOW TO ERASE EMISSION-RELATED DIAGNOSTIC INFORMATION", EC-55.</li> <li>Make sure DTC No. 0505 is displayed in Diagnostic Test Mode II.</li> <li>Run engine for at least 10 minutes at idle speed. <b>Is the 1st trip DTC 0115 or 0210 detected? Is it difficult to start engine?</b></li> </ol> <p style="text-align: center;"><b>Yes or No</b></p>																					
Yes	▶ Perform trouble diagnosis for DTC P0171, P0174. Refer to EC-247.																				
No	▶ GO TO 4.																				

<b>4</b>	<b>CHECK FRONT HEATED OXYGEN SENSOR HEATER</b>
Refer to "Component Inspection", EC-207.	
<b>OK or NG</b>	
OK	▶ GO TO 5.
NG	▶ Replace malfunctioning front heated oxygen sensor.

GI

MA

EM

LC

EC

FE

CL

MT

AT

TF

PD

FA

RA

BR

ST

RS

BT

HA

EL

IDX

# DTC P0131 (RIGHT BANK, -B1), P0151 (LEFT BANK, -B2) FRONT HEATED OXYGEN SENSOR (FRONT HO2S) (LEAN SHIFT MONITORING)

Diagnostic Procedure (Cont'd)

<b>5</b>	<b>CHECK FRONT HEATED OXYGEN SENSOR</b>
Refer to "Component Inspection", EC-178.	
<b>OK or NG</b>	
OK	▶ GO TO 6.
NG	▶ Replace malfunctioning front heated oxygen sensor.

<b>7</b>	<b>CHECK INTERMITTENT INCIDENT</b>
Refer to "TROUBLE DIAGNOSIS FOR INTERMITTENT INCIDENT", EC-115.	
For circuit, refer to "DTC P0130 (RIGHT BANK, -B1), P0150 (LEFT BANK, -B2) FRONT HEATED OXYGEN SENSOR (FRONT HO2S) (CIRCUIT)", EC-166.	
▶ <b>INSPECTION END</b>	

<b>6</b>	<b>CHECK SHIELD CIRCUIT</b>
<ol style="list-style-type: none"> <li>Turn ignition switch "OFF".</li> <li>Disconnect joint connector.</li> <li>For circuit, refer to "DTC P0130 (RIGHT BANK, -B1), P0150 (LEFT BANK, -B2) FRONT HEATED OXYGEN SENSOR (FRONT HO2S) (CIRCUIT)", EC-166.</li> <li>Check the following. <ul style="list-style-type: none"> <li>Continuity between joint connector terminal and ground</li> <li>Joint connector (Refer to "HARNES LAYOUT" in EL section.)</li> </ul> <p style="text-align: center;"><b>Continuity should exist.</b></p> </li> <li>Also check harness for short to ground and short to power.</li> <li>Then reconnect joint connector.</li> </ol>	
<b>OK or NG</b>	
OK	▶ GO TO 7.
NG	▶ Repair open circuit or short to ground or short to power in harness or connectors.

☆ MONITOR	☆ NO FAIL	<input type="checkbox"/>
CMPS-RPM(REF)	2137rpm	
MAS AIR/FL SE	1.96V	
COOLAN TEMP/S	84°C	
FR O2 SEN-B1	0.37V	
FR O2 MNTR-B1	LEAN	
INJ PULSE-B1	2.6msec	
A/F ALPHA-B1	101%	
FR O2 HTR-B1	ON	
<b>RECORD</b>		

SEF365V

Right bank	
cycle	1   2   3   4   5
FR O2 MNTR-B1	R-L-R-L-R-L-R-L-R-L-R
Left bank	
cycle	1   2   3   4   5
FR O2 MNTR-B2	R-L-R-L-R-L-R-L-R-L-R
R means FR O2 MNTR-B1(-B2) indicates RICH	
L means FR O2 MNTR-B1(-B2) indicates LEAN	

SEF702W

## Component Inspection FRONT HEATED OXYGEN SENSOR

NEEC0400

NEEC0400S01

### Ⓛ With CONSULT

- Start engine and warm it up to normal operating temperature.
- Select "MANU TRIG" and "HI SPEED" in "DATA MONITOR" mode with CONSULT, and select "FR O2 SEN-B1 (-B2)" and "FR O2 MNTR-B1 (-B2)".
- Hold engine speed at 2,000 rpm under no load during the following steps.
- Touch "RECORD" on CONSULT screen.
- Check the following.
  - "FR O2 MNTR-B1 (-B2)" in "DATA MONITOR" mode changes from "RICH" to "LEAN" to "RICH" 5 times in 10 seconds. 5 times (cycles) are counted as shown left:
  - "FR O2 SEN-B1 (-B2)" voltage goes above 0.6V at least once.
  - "FR O2 SEN-B1 (-B2)" voltage goes below 0.3V at least once.
  - "FR O2 SEN-B1 (-B2)" voltage never exceeds 1.0V.

### CAUTION:

**Discard any heated oxygen sensor which has been dropped from a height of more than 0.5 m (19.7 in) onto a hard surface such as a concrete floor; use a new one.**



# DTC P0131 (RIGHT BANK, -B1), P0151 (LEFT BANK, -B2) FRONT HEATED OXYGEN SENSOR (FRONT HO2S) (LEAN SHIFT MONITORING)

Component Inspection (Cont'd)

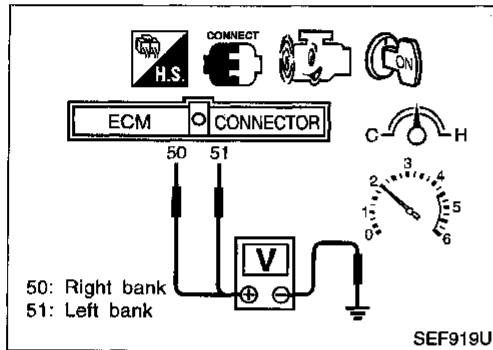
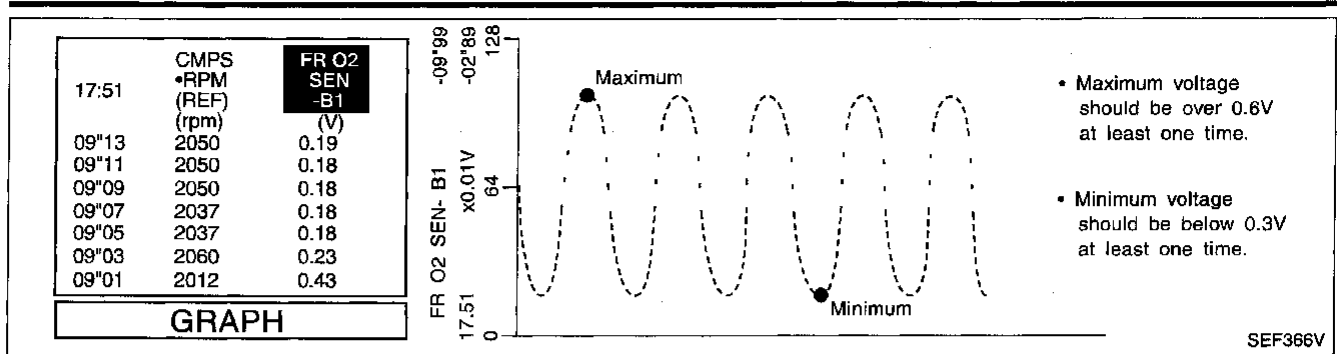

## ⊗ Without CONSULT

- 1) Start engine and warm it up to normal operating temperature.
- 2) Set voltmeter probes between ECM terminal 50 (right bank sensor signal) or 51 (left bank sensor signal) and engine ground.
- 3) Check the following with engine speed held at 2,000 rpm constant under no load.
  - MIL goes on more than 5 times within 10 seconds in Diagnostic Test Mode II (FRONT HEATED OXYGEN SENSOR MONITOR).
  - The maximum voltage is over 0.6V at least one time.
  - The minimum voltage is below 0.3V at least one time.
  - The voltage never exceeds 1.0V.

## CAUTION:

Discard any heated oxygen sensor which has been dropped from a height of more than 0.5 m (19.7 in) onto a hard surface such as a concrete floor; use a new one.

GI

MA

EM

LC

EC

FE

CL

MT

AT

TF

PD

FA

RA

BR

ST

RS

BT

HA

EL

IDX

# DTC P0132 (RIGHT BANK, -B1), P0152 (LEFT BANK, -B2) FRONT HEATED OXYGEN SENSOR (FRONT HO2S) (RICH SHIFT MONITORING)

## Component Description

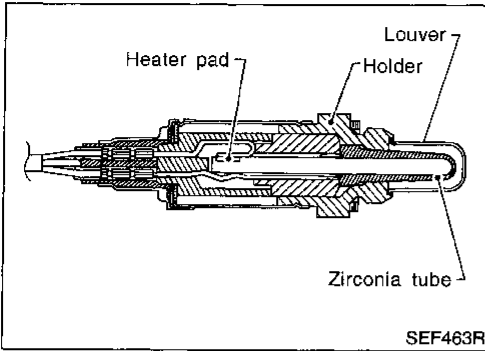

## Component Description

The front heated oxygen sensor is placed into the front tube. It detects the amount of oxygen in the exhaust gas compared to the outside air. The front heated oxygen sensor has a closed-end tube made of ceramic zirconia. The zirconia generates voltage from approximately 1V in richer conditions to 0V in leaner conditions. The front heated oxygen sensor signal is sent to the ECM. The ECM adjusts the injection pulse duration to achieve the ideal air-fuel ratio. The ideal air-fuel ratio occurs near the radical change from 1V to 0V.

NEEC0401

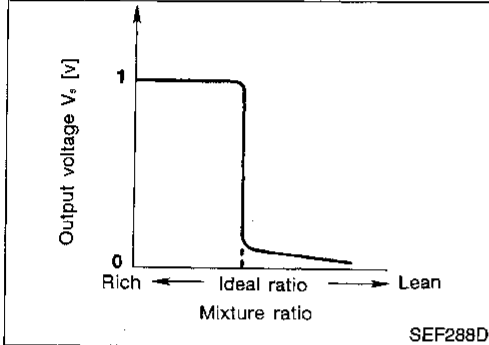

## CONSULT Reference Value in Data Monitor Mode

Specification data are reference values.

NEEC0402

MONITOR ITEM	CONDITION	SPECIFICATION
FR O2 SEN-B1 FR O2 SEN-B2	<ul style="list-style-type: none"> <li>Engine: After warming up</li> </ul> Maintaining engine speed at 2,000 rpm	0 - 0.3V ↔ Approx. 0.6 - 1.0V
FR O2 MNTR-B1 FR O2 MNTR-B2		LEAN ↔ RICH Changes more than 5 times during 10 seconds.

## ECM Terminals and Reference Value

Specification data are reference values and are measured between each terminal and 32 (ECM ground).

NEEC0403

TERMINAL NO.	WIRE COLOR	ITEM	CONDITION	DATA (DC Voltage)
50	B	Front heated oxygen sensor RH	[Engine is running] • After warming up to normal operating temperature and engine speed is 2,000 rpm	0 - Approximately 1.0V 
51	G	Front heated oxygen sensor LH		

SEF002V

# DTC P0132 (RIGHT BANK, -B1), P0152 (LEFT BANK, -B2) FRONT HEATED OXYGEN SENSOR (FRONT HO2S) (RICH SHIFT MONITORING)

On Board Diagnosis Logic

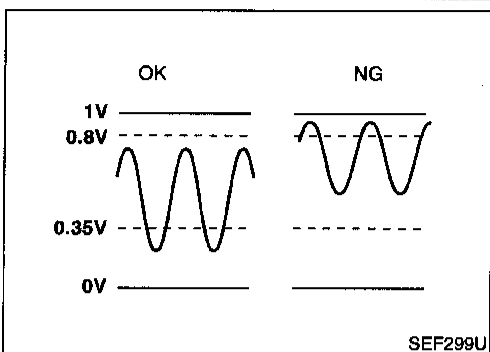

## On Board Diagnosis Logic

To judge the malfunction, the output from the front heated oxygen sensor is monitored to determine whether the "rich" output is sufficiently high. The "lean" output is sufficiently low. When both the outputs are shifting to the rich side, the malfunction will be detected.

DTC No.	Malfunction is detected when ...	Check Items (Possible Cause)
P0132 0414 (Right bank)	<ul style="list-style-type: none"> <li>The maximum and minimum voltages from the sensor are beyond the specified voltages.</li> </ul>	<ul style="list-style-type: none"> <li>Front heated oxygen sensor</li> <li>Fuel pressure</li> <li>Injectors</li> <li>Front heated oxygen sensor heater</li> </ul>
P0152 0410 (Left bank)		

## DTC Confirmation Procedure

### CAUTION:

Always drive vehicle at a safe speed.

### NOTE:

If "DTC Confirmation Procedure" has been previously conducted, always turn ignition switch "OFF" and wait at least 5 seconds before conducting the next test.

### TESTING CONDITION:

- Always perform at a temperature above  $-10^{\circ}\text{C}$  ( $14^{\circ}\text{F}$ ).
- Before performing the following procedure, confirm that battery voltage is more than 11V at idle.

# DTC P0132 (RIGHT BANK, -B1), P0152 (LEFT BANK, -B2) FRONT HEATED OXYGEN SENSOR (FRONT HO2S) (RICH SHIFT MONITORING)

DTC Confirmation Procedure (Cont'd)

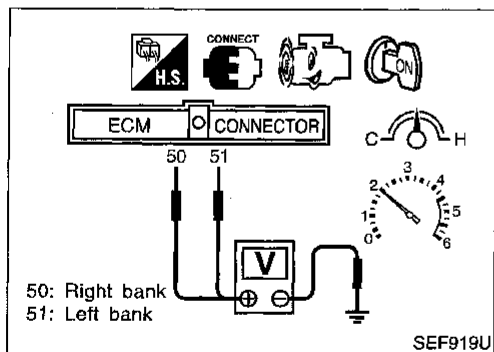
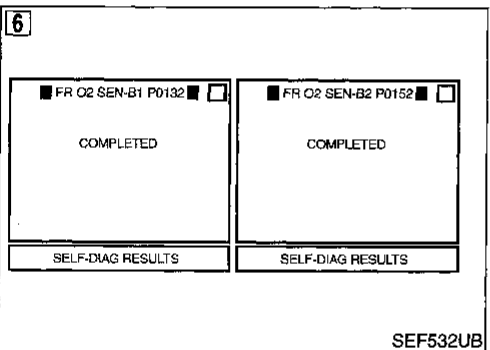
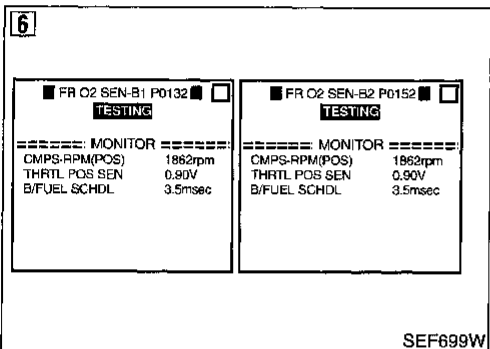
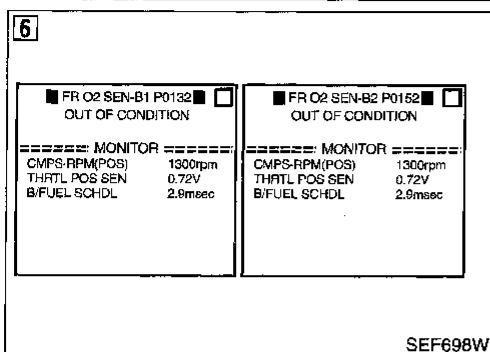

## With CONSULT

- 1) Start engine and warm it up to normal operating temperature.
- 2) Stop engine and wait at least 5 seconds.
- 3) Turn ignition switch "ON" and select "FR O2 SEN-B1 (-B2) P0132 (P0152)" of "FRONT O2 SENSOR" in "DTC WORK SUPPORT" mode with CONSULT.
- 4) Touch "START".
- 5) Start engine and let it idle for at least 3.5 minutes.

### NOTE:

Never raise engine speed above 3,200 rpm after this step. If the engine speed limit is exceeded, return to step 5.

- 6) When the following conditions are met, "TESTING" will be displayed on the CONSULT screen. Maintain the conditions continuously until "TESTING" changes to "COMPLETED". (It will take approximately 50 seconds or more.)

CMPS-RPM (POS)	1,800 - 2,800 rpm
Vehicle speed	80 - 100 km/h (50 - 62 MPH)
B/FUEL SCHDL	1.7 - 6.5 msec
Selector lever	Suitable position

If "TESTING" is not displayed after 5 minutes, retry from step 2.

- 7) Make sure that "OK" is displayed after touching "SELF-DIAG RESULTS". If "NG" is displayed, refer to "Diagnostic Procedure", EC-183.

## Overall Function Check

NEEC0406

Use this procedure to check the overall function of the front heated oxygen sensor circuit. During this check, a 1st trip DTC might not be confirmed.

### Without CONSULT

- 1) Start engine and warm it up to normal operating temperature.
- 2) Set voltmeter probes between ECM terminal 50 (right bank sensor signal) or 51 (left bank sensor signal) and engine ground.
- 3) Check one of the following with engine speed held at 2,000 rpm constant under no load.
  - The maximum voltage is below 0.8V at least one time.
  - The minimum voltage is below 0.35V at least one time.
- 4) If NG, go to "Diagnostic Procedure", EC-183.

# DTC P0132 (RIGHT BANK, -B1), P0152 (LEFT BANK, -B2) FRONT HEATED OXYGEN SENSOR (FRONT HO2S) (RICH SHIFT MONITORING)

Diagnostic Procedure

## Diagnostic Procedure

NEEC0408

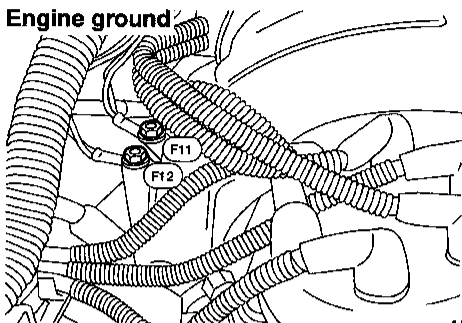
<b>1</b>	<b>RETIGHTEN GROUND SCREWS</b>
<ol style="list-style-type: none"> <li>Turn ignition switch "OFF".</li> <li>Loosen and retighten engine ground screws.</li> </ol>	
 <p>Engine ground</p> <p style="text-align: right;">AEC640A</p>	
<p>▶ GO TO 2.</p>	

<b>2</b>	<b>RETIGHTEN FRONT HEATED OXYGEN SENSOR</b>
Loosen and retighten corresponding front heated oxygen sensor.	
<b>Tightening torque:</b> <b>40 - 50 N·m (4.1 - 5.1 kg·m, 30 - 37 ft·lb)</b>	
<p>▶ GO TO 3.</p>	

<b>3</b>	<b>CLEAR THE SELF-LEARNING DATA</b>																				
<p><b>Ⓢ With CONSULT</b></p> <ol style="list-style-type: none"> <li>Start engine and warm it up to normal operating temperature.</li> <li>Select "SELF-LEARNING CONT" in "ACTIVE TEST" mode with CONSULT.</li> <li>Clear the self-learning control coefficient by touching "CLEAR".</li> </ol>																					
<table border="1" style="width: 100%;"> <tr> <td colspan="2" style="text-align: center;">■ ACTIVE TEST ■ <input type="checkbox"/></td> </tr> <tr> <td>SELF-LEARN CONTROL</td> <td>B1 : 100% B2 : 100%</td> </tr> <tr> <td colspan="2" style="text-align: center;">----- MONITOR -----</td> </tr> <tr> <td>CMP5-RPM(REF)</td> <td>750rpm</td> </tr> <tr> <td>COOLAN TEMP/S</td> <td>93°C</td> </tr> <tr> <td>FR O2 SEN-B1</td> <td>0.90V</td> </tr> <tr> <td>FR O2 SEN-B2</td> <td>0.90V</td> </tr> <tr> <td>A/F ALPHA-B1</td> <td>100%</td> </tr> <tr> <td>A/F ALPHA-B2</td> <td>100%</td> </tr> <tr> <td colspan="2" style="text-align: center;"><b>CLEAR</b></td> </tr> </table>		■ ACTIVE TEST ■ <input type="checkbox"/>		SELF-LEARN CONTROL	B1 : 100% B2 : 100%	----- MONITOR -----		CMP5-RPM(REF)	750rpm	COOLAN TEMP/S	93°C	FR O2 SEN-B1	0.90V	FR O2 SEN-B2	0.90V	A/F ALPHA-B1	100%	A/F ALPHA-B2	100%	<b>CLEAR</b>	
■ ACTIVE TEST ■ <input type="checkbox"/>																					
SELF-LEARN CONTROL	B1 : 100% B2 : 100%																				
----- MONITOR -----																					
CMP5-RPM(REF)	750rpm																				
COOLAN TEMP/S	93°C																				
FR O2 SEN-B1	0.90V																				
FR O2 SEN-B2	0.90V																				
A/F ALPHA-B1	100%																				
A/F ALPHA-B2	100%																				
<b>CLEAR</b>																					
SEF921U																					
<ol style="list-style-type: none"> <li>Run engine for at least 10 minutes at idle speed.  <b>Is the 1st trip DTC P0172 or P0175 detected?</b>  <b>Is it difficult to start engine?</b> </li> </ol>																					
<p><b>ⓧ Without CONSULT</b></p> <ol style="list-style-type: none"> <li>Start engine and warm it up to normal operating temperature.</li> <li>Turn ignition switch "OFF".</li> <li>Disconnect mass air flow sensor harness connector, and restart and run engine for at least 5 seconds at idle speed.</li> <li>Stop engine and reconnect mass air flow sensor harness connector.</li> <li>Make sure 1st trip DTC No. 0102 is displayed in Diagnostic Test Mode II.</li> <li>Erase the diagnostic test mode II (Self-diagnostic results) memory. Refer to "HOW TO ERASE EMISSION-RELATED DIAGNOSTIC INFORMATION", EC-55.</li> <li>Make sure DTC No. 0505 is displayed in Diagnostic Test Mode II.</li> <li>Run engine for at least 10 minutes at idle speed.  <b>Is the 1st trip DTC 0114 or 0209 detected?</b>  <b>Is it difficult to start engine?</b> </li> </ol>																					
<b>Yes or No</b>																					
Yes	▶ Perform trouble diagnosis for DTC P0172, P0175. Refer to EC-254.																				
No	▶ GO TO 4.																				

<b>4</b>	<b>CHECK CONNECTOR FOR WATER</b>
<ol style="list-style-type: none"> <li>Turn ignition switch "OFF".</li> <li>Disconnect front heated oxygen sensor harness connector.</li> <li>Check connectors for water.  <b>Water should not exist.</b> </li> </ol>	
<b>OK or NG</b>	
OK	▶ GO TO 5.
NG	▶ Repair or replace harness or connectors.

GI  
MA  
EM  
LC  
EC  
FE  
CL  
MT  
AT  
TF  
PD  
FA  
RA  
BR  
ST  
RS  
BT  
HA  
EL  
IDX

# DTC P0132 (RIGHT BANK, -B1), P0152 (LEFT BANK, -B2) FRONT HEATED OXYGEN SENSOR (FRONT HO2S) (RICH SHIFT MONITORING)

Diagnostic Procedure (Cont'd)

<b>5</b>	<b>CHECK FRONT HEATED OXYGEN SENSOR HEATER</b>
Refer to "Component Inspection", EC-207.	
<b>OK or NG</b>	
OK	▶ GO TO 6.
NG	▶ Replace malfunctioning front heated oxygen sensor.

<b>6</b>	<b>CHECK FRONT HEATED OXYGEN SENSOR</b>
Refer to "Component Inspection", EC-184.	
<b>OK or NG</b>	
OK	▶ GO TO 7.
NG	▶ Replace malfunctioning front heated oxygen sensor.

<b>7</b>	<b>CHECK SHIELD CIRCUIT</b>
1. Turn ignition switch "OFF". 2. Disconnect joint connector. For circuit, refer to "DTC P0130 (RIGHT BANK, -B1), P0150 (LEFT BANK, -B2) FRONT HEATED OXYGEN SENSOR (FRONT HO2S) (CIRCUIT)", EC-166. 3. Check the following. <ul style="list-style-type: none"> <li>• Continuity between joint connector terminal and ground</li> <li>• Joint connector (Refer to "HARNES LAYOUT" in EL section.)</li> </ul> <b>Continuity should exist.</b> 4. Also check harness for short to ground and short to power. 5. Then reconnect joint connector.	
<b>OK or NG</b>	
OK	▶ GO TO 8.
NG	▶ Repair open circuit or short to ground or short to power in harness or connectors.

<b>8</b>	<b>CHECK INTERMITTENT INCIDENT</b>
Refer to "TROUBLE DIAGNOSIS FOR INTERMITTENT INCIDENT", EC-115. For circuit, refer to "DTC P0130 (RIGHT BANK, -B1), P0150 (LEFT BANK, -B2) FRONT HEATED OXYGEN SENSOR (FRONT HO2S) (CIRCUIT)", EC-166.	
▶ <b>INSPECTION END</b>	

☆ MONITOR	☆ NO FAIL <input type="checkbox"/>
CMPS•RPM(REF)	2137rpm
MAS AIR/FL SE	1.96V
COOLAN TEMP/S	84°C
FR O2 SEN-B1	0.37V
FR O2 MNTR-B1	LEAN
INJ PULSE-B1	2.6msec
A/F ALPHA-B1	101%
FR O2 HTR-B1	ON

RECORD

SEF365V

Right bank

cycle	1   2   3   4   5
FR O2 MNTR-B1	R-L-R-L-R-L-R-L-R-L-R

Left bank

cycle	1   2   3   4   5
FR O2 MNTR-B2	R-L-R-L-R-L-R-L-R-L-R

R means FR O2 MNTR-B1(-B2) indicates RICH  
L means FR O2 MNTR-B1(-B2) indicates LEAN

SEF702W

## Component Inspection FRONT HEATED OXYGEN SENSOR

NEEC0409

NEEC0409S01

### Ⓢ With CONSULT

- 1) Start engine and warm it up to normal operating temperature.
- 2) Select "MANU TRIG" and "HI SPEED" in "DATA MONITOR" mode with CONSULT, and select "FR O2 SEN-B1 (-B2)" and "FR O2 MNTR-B1 (-B2)".
- 3) Hold engine speed at 2,000 rpm under no load during the following steps.
- 4) Touch "RECORD" on CONSULT screen.
- 5) Check the following.
  - "FR O2 MNTR-B1 (-B2)" in "DATA MONITOR" mode changes from "RICH" to "LEAN" to "RICH" 5 times in 10 seconds. 5 times (cycles) are counted as shown left:
  - "FR O2 SEN-B1 (-B2)" voltage goes above 0.6V at least once.
  - "FR O2 SEN-B1 (-B2)" voltage goes below 0.3V at least once.
  - "FR O2 SEN-B1 (-B2)" voltage never exceeds 1.0V.

### CAUTION:

**Discard any heated oxygen sensor which has been dropped from a height of more than 0.5 m (19.7 in) onto a hard surface such as a concrete floor; use a new one.**

# DTC P0132 (RIGHT BANK, -B1), P0152 (LEFT BANK, -B2) FRONT HEATED OXYGEN SENSOR (FRONT HO2S) (RICH SHIFT MONITORING)

Component Inspection (Cont'd)

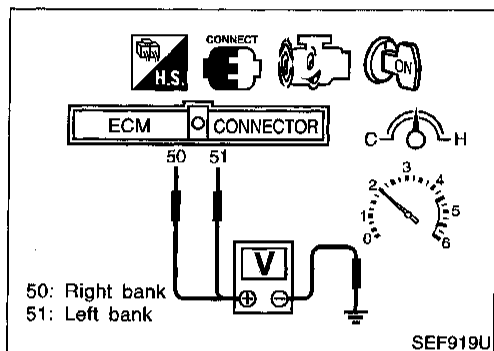
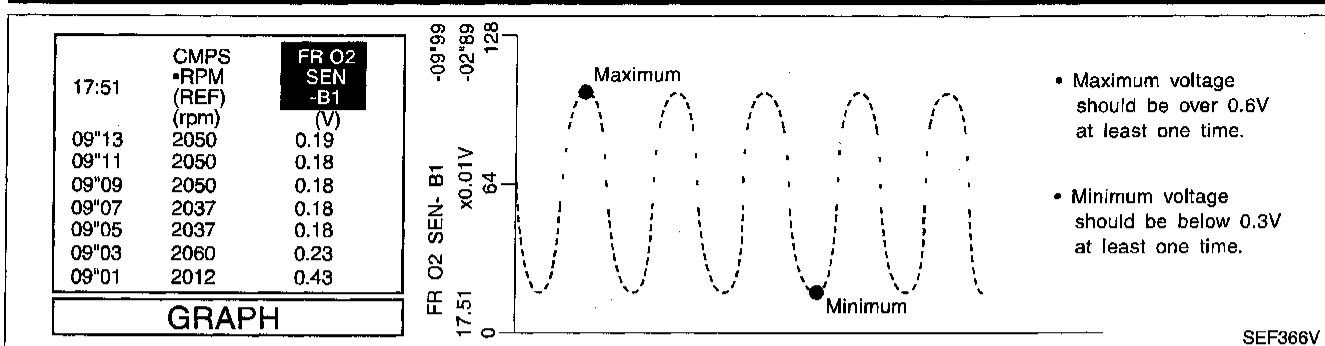

## ⊗ Without CONSULT

- 1) Start engine and warm it up to normal operating temperature.
- 2) Set voltmeter probes between ECM terminal 50 (right bank sensor signal) or 51 (left bank sensor signal) and engine ground.
- 3) Check the following with engine speed held at 2,000 rpm constant under no load.
  - MIL goes on more than 5 times within 10 seconds in Diagnostic Test Mode II (FRONT HEATED OXYGEN SENSOR MONITOR).
  - The maximum voltage is over 0.6V at least one time.
  - The minimum voltage is below 0.3V at least one time.
  - The voltage never exceeds 1.0V.

## CAUTION:

Discard any heated oxygen sensor which has been dropped from a height of more than 0.5 m (19.7 in) onto a hard surface such as a concrete floor; use a new one.

# DTC P0133 (RIGHT BANK, -B1), P0153 (LEFT BANK, -B2) FRONT HEATED OXYGEN SENSOR (FRONT HO2S) (RESPONSE MONITORING)

## Component Description

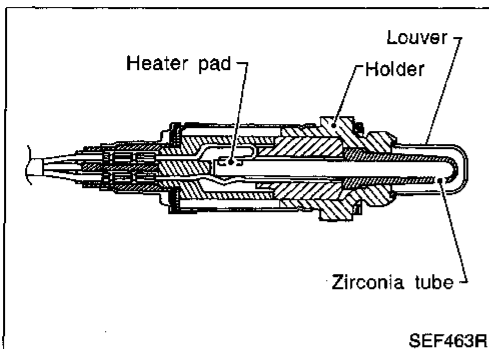

SEF463R

## Component Description

NEEC0410

The front heated oxygen sensor is placed into the front tube. It detects the amount of oxygen in the exhaust gas compared to the outside air. The front heated oxygen sensor has a closed-end tube made of ceramic zirconia. The zirconia generates voltage from approximately 1V in richer conditions to 0V in leaner conditions. The front heated oxygen sensor signal is sent to the ECM. The ECM adjusts the injection pulse duration to achieve the ideal air-fuel ratio. The ideal air-fuel ratio occurs near the radical change from 1V to 0V.

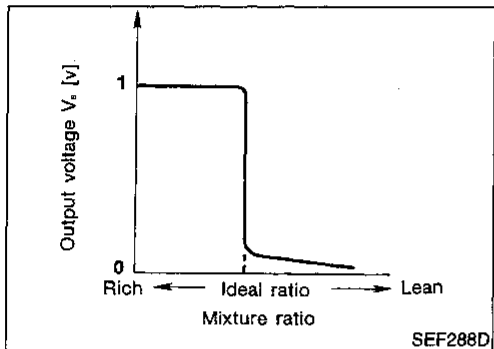

SEF288D

## CONSULT Reference Value in Data Monitor Mode

NEEC0411

Specification data are reference values.

MONITOR ITEM	CONDITION	SPECIFICATION
FR O2 SEN-B1 FR O2 SEN-B2	<ul style="list-style-type: none"> <li>Engine: After warming up</li> </ul> Maintaining engine speed at 2,000 rpm	0 - 0.3V ↔ Approx. 0.6 - 1.0V
FR O2 MNTR-B1 FR O2 MNTR-B2		LEAN ↔ RICH Changes more than 5 times during 10 seconds.

## ECM Terminals and Reference Value

NEEC0412

Specification data are reference values and are measured between each terminal and 32 (ECM ground).

TERMI-NAL NO.	WIRE COLOR	ITEM	CONDITION	DATA (DC Voltage)
50	B	Front heated oxygen sensor RH	<b>[Engine is running]</b> <ul style="list-style-type: none"> <li>After warming up to normal operating temperature and engine speed is 2,000 rpm</li> </ul>	0 - Approximately 1.0V
51	G	Front heated oxygen sensor LH		

SEF002V



# DTC P0133 (RIGHT BANK, -B1), P0153 (LEFT BANK, -B2) FRONT HEATED OXYGEN SENSOR (FRONT HO2S) (RESPONSE MONITORING)

On Board Diagnosis Logic

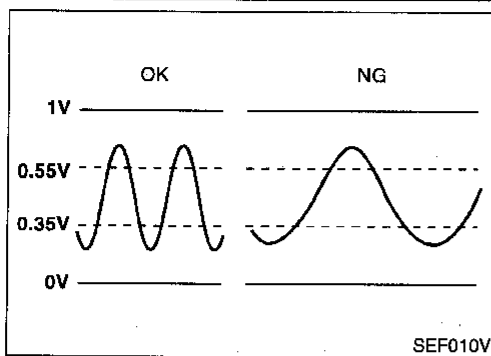

## On Board Diagnosis Logic

NEEC0413

To judge the malfunction of front heated oxygen sensor, this diagnosis measures response time of front heated oxygen sensor signal. The time is compensated by engine operating (speed and load), fuel feedback control constant, and front heated oxygen sensor temperature index. Judgment is based on whether the compensated time (front heated oxygen sensor cycling time index) is inordinately long or not.

DTC No.	Malfunction is detected when ...	Check Items (Possible Cause)
P0133 0413 (Right bank)	<ul style="list-style-type: none"> <li>The response of the voltage signal from the sensor takes more than the specified time.</li> </ul>	<ul style="list-style-type: none"> <li>Harness or connectors (The sensor circuit is open or shorted.)</li> <li>Front heated oxygen sensor</li> <li>Front heated oxygen sensor heater</li> <li>Fuel pressure</li> <li>Injectors</li> <li>Intake air leaks</li> <li>Exhaust gas leaks</li> <li>PCV valve</li> <li>Mass air flow sensor</li> </ul>
P0153 0409 (Left bank)		

## DTC Confirmation Procedure

NEEC0414

### CAUTION:

Always drive vehicle at a safe speed.

### NOTE:

If "DTC Confirmation Procedure" has been previously conducted, always turn ignition switch "OFF" and wait at least 5 seconds before conducting the next test.

### TESTING CONDITION:

- Always perform at a temperature above  $-10^{\circ}\text{C}$  ( $14^{\circ}\text{F}$ ).
- Before performing the following procedure, confirm that battery voltage is more than 11V at idle.

GI  
MA  
EM  
LC  
EC  
FE  
CL  
MT  
AT  
TF  
PD  
FA  
RA  
BR  
ST  
RS  
BT  
HA  
EL  
IDX

# DTC P0133 (RIGHT BANK, -B1), P0153 (LEFT BANK, -B2) FRONT HEATED OXYGEN SENSOR (FRONT HO2S) (RESPONSE MONITORING)

## DTC Confirmation Procedure (Cont'd)

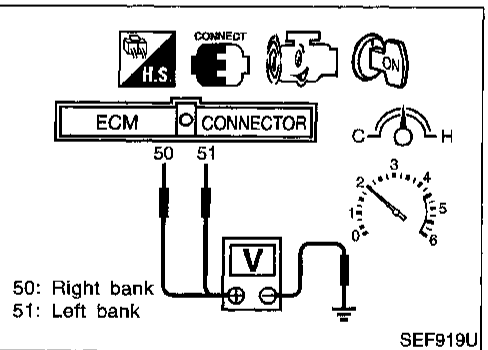
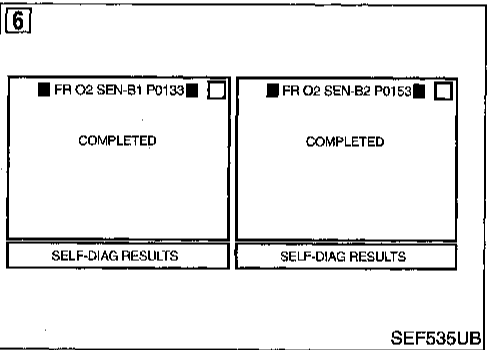
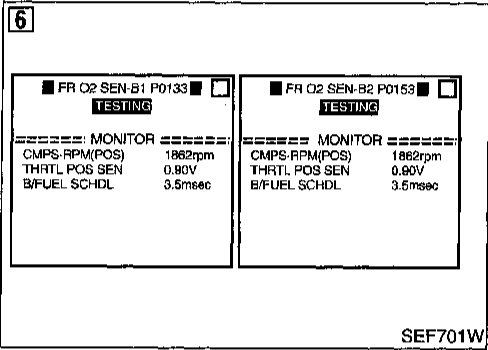
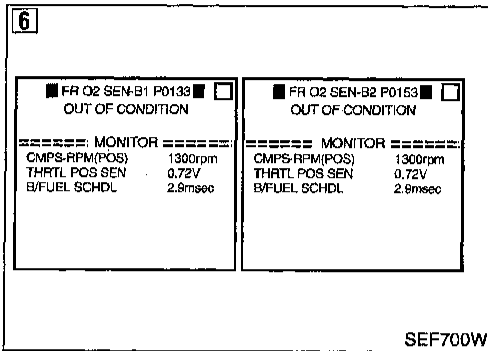

### With CONSULT

- 1) Start engine and warm it up to normal operating temperature.
- 2) Stop engine and wait at least 5 seconds.
- 3) Turn ignition switch "ON" and select "FR O2 SEN-B1 (-B2) P0133 (P0153)" of "FRONT O2 SENSOR" in "DTC WORK SUPPORT" mode with CONSULT.
- 4) Touch "START".
- 5) Start engine and let it idle for at least 3.5 minutes.

### NOTE:

Never raise engine speed above 3,200 rpm after this step. If the engine speed limit is exceeded, return to step 5.

- 6) When the following conditions are met, "TESTING" will be displayed on the CONSULT screen. Maintain the conditions continuously until "TESTING" changes to "COMPLETED". (It will take approximately 40 to 50 seconds.)

CMPS-RPM (POS)	1,800 - 2,800 rpm
Vehicle speed	80 - 100 km/h (50 - 62 MPH)
B/FUEL SCHDL	1.7 - 6.5 msec
Selector lever	Suitable position

If "TESTING" is not displayed after 5 minutes, retry from step 2.

- 7) Make sure that "OK" is displayed after touching "SELF-DIAG RESULTS". If "NG" is displayed, refer to "Diagnostic Procedure", EC-191.

## Overall Function Check

NEEC0415

Use this procedure to check the overall function of the front heated oxygen sensor circuit. During this check, a 1st trip DTC might not be confirmed.

### Without CONSULT

- 1) Start engine and warm it up to normal operating temperature.
- 2) Set voltmeter probes between ECM terminal 50 (right bank sensor signal) or 51 (left bank sensor signal) and engine ground.
- 3) Check the following with engine speed held at 2,000 rpm constant under no load.
  - MIL goes on more than 5 times within 10 seconds in Diagnostic Test Mode II (FRONT HEATED OXYGEN SENSOR MONITOR).
- 4) If NG, go to "Diagnostic Procedure", EC-191.

# DTC P0133 (RIGHT BANK, -B1), P0153 (LEFT BANK, -B2) FRONT HEATED OXYGEN SENSOR (FRONT HO2S) (RESPONSE MONITORING)

Wiring Diagram

## Wiring Diagram

RIGHT BANK

NEEC0416

NEEC0416S01

EC-FRO2RH-01

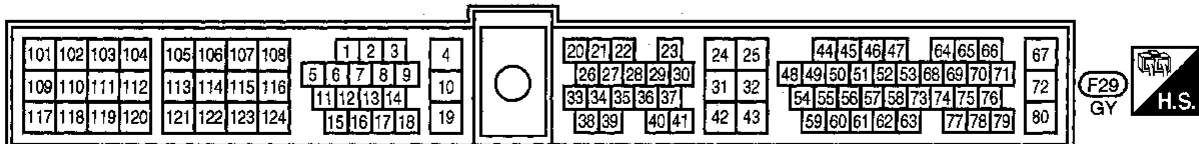
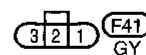
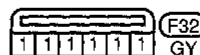
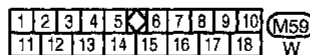
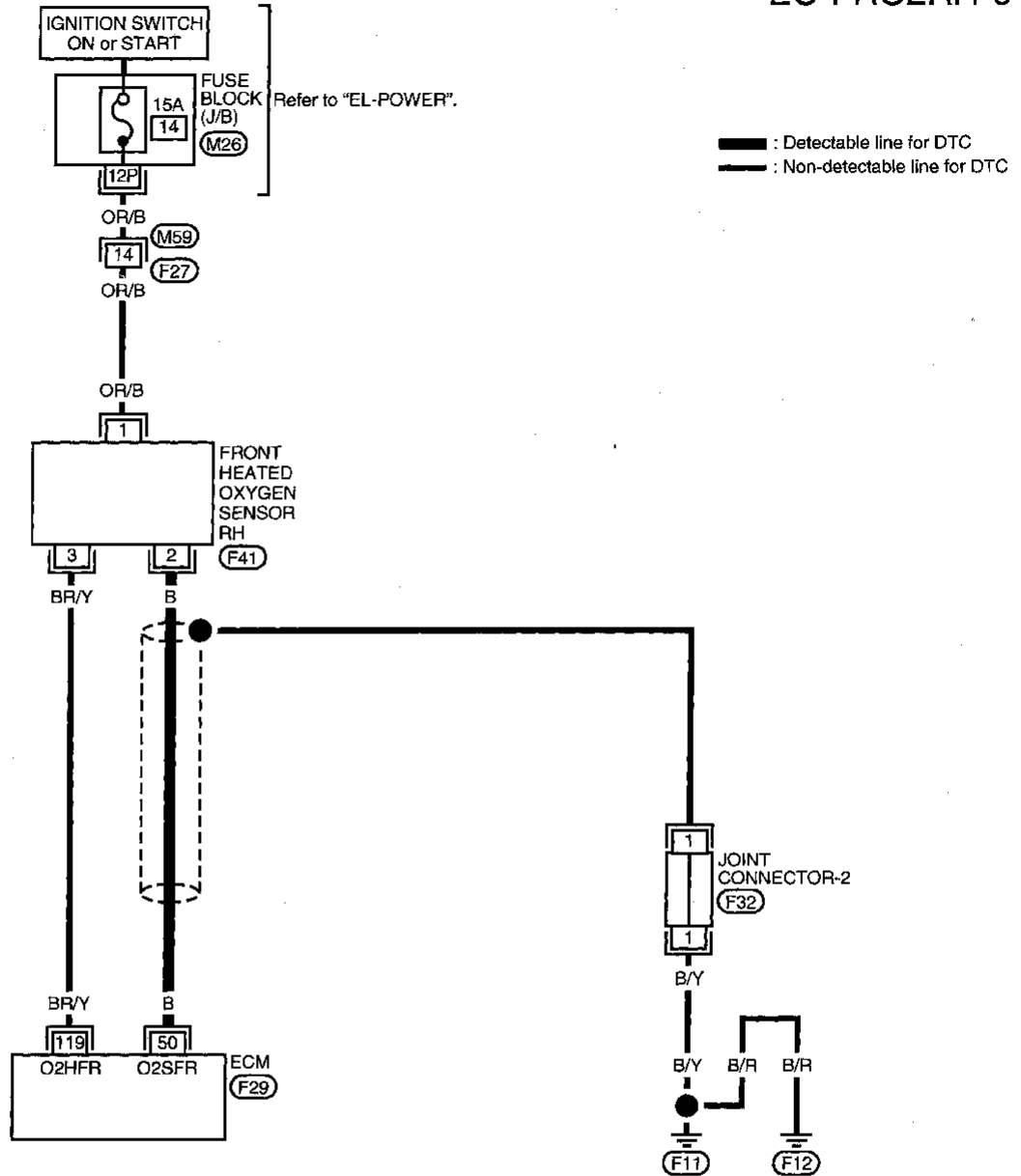

# DTC P0133 (RIGHT BANK, -B1), P0153 (LEFT BANK, -B2) FRONT HEATED OXYGEN SENSOR (FRONT HO2S) (RESPONSE MONITORING)

Wiring Diagram (Cont'd)

## LEFT BANK

NEEC0418S02

### EC-FRO2LH-01

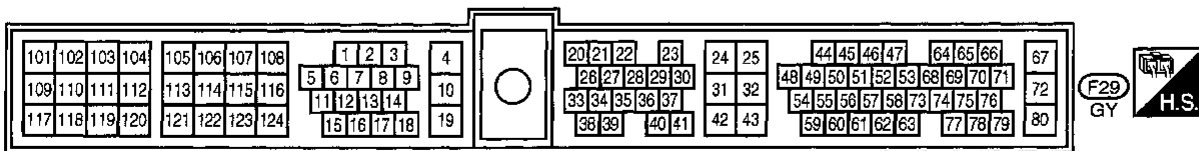
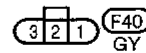
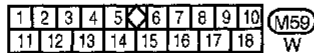
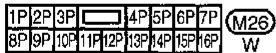
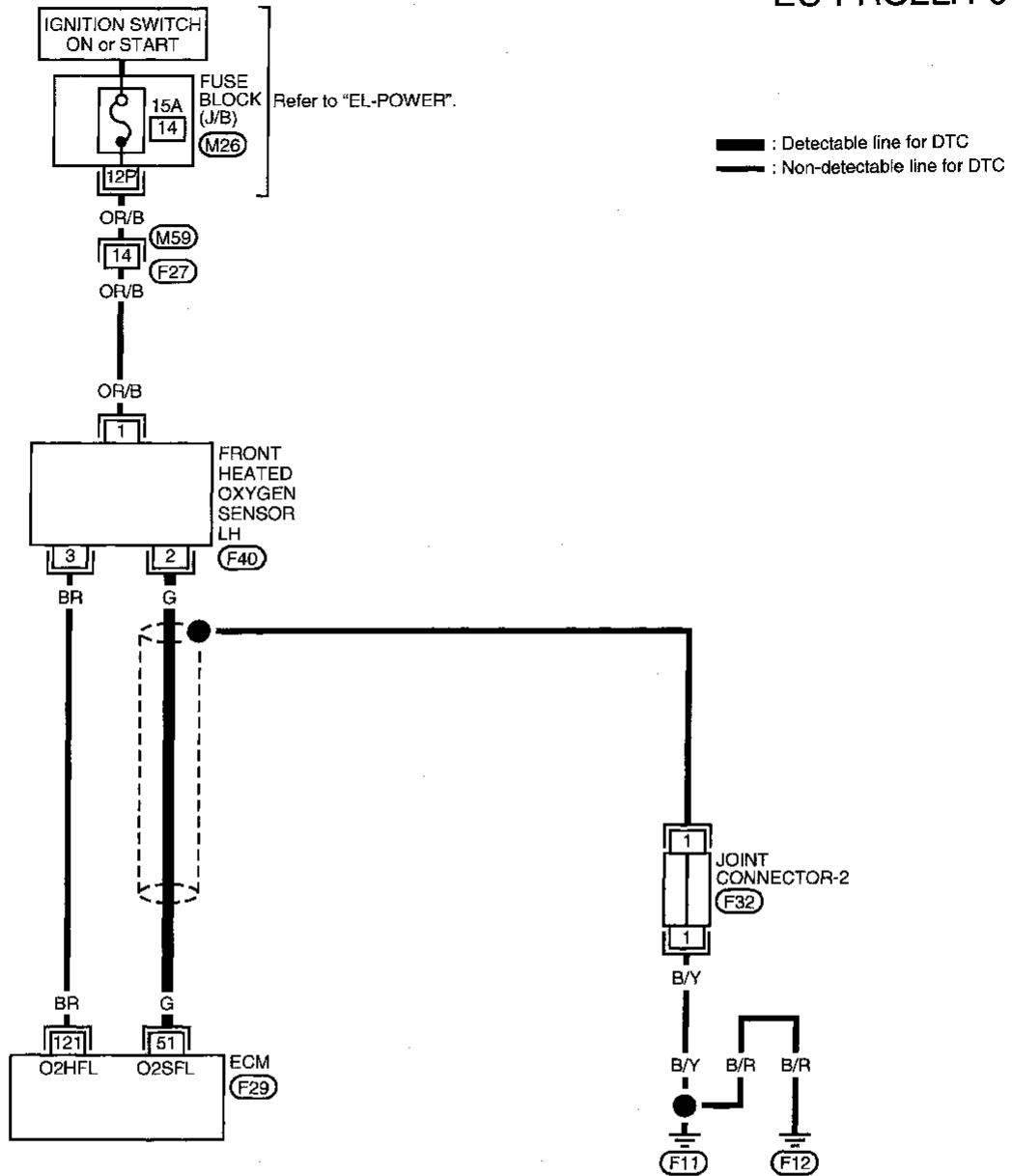

AEC730A

# DTC P0133 (RIGHT BANK, -B1), P0153 (LEFT BANK, -B2) FRONT HEATED OXYGEN SENSOR (FRONT HO2S) (RESPONSE MONITORING)

Diagnostic Procedure

## Diagnostic Procedure

NEEC0417

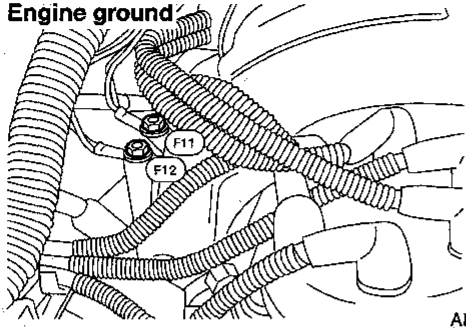
<b>1</b>	<b>RETIGHTEN GROUND SCREWS</b>
<ol style="list-style-type: none"> <li>Turn ignition switch "OFF".</li> <li>Loosen and retighten engine ground screws.</li> </ol>	
<p style="text-align: center;"><b>Engine ground</b></p>  <p style="text-align: right;">AEC640A</p>	
▶ GO TO 2.	

<b>2</b>	<b>RETIGHTEN FRONT HEATED OXYGEN SENSOR</b>
Loosen and retighten corresponding front heated oxygen sensor.	
<p><b>Tightening torque:</b> 40 - 50 N·m (4.1 - 5.1 kg·m, 30 - 37 ft·lb)</p>	
▶ GO TO 3.	

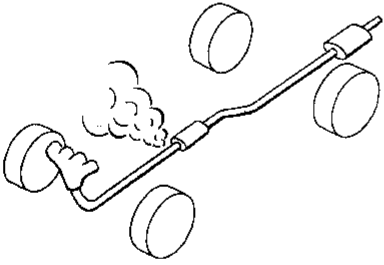
<b>3</b>	<b>CHECK FOR EXHAUST AIR LEAK</b>
<ol style="list-style-type: none"> <li>Start engine and run it at idle.</li> <li>Listen for an exhaust air leak before three way catalyst.</li> </ol>	
 <p style="text-align: right;">SEF099P</p>	
<b>OK or NG</b>	
OK	▶ GO TO 4.
NG	▶ Repair or replace.

<b>4</b>	<b>CHECK FOR INTAKE AIR LEAK</b>
Listen for an intake air leak after the mass air flow sensor.	
<b>OK or NG</b>	
OK	▶ GO TO 5.
NG	▶ Repair or replace.

<b>5</b>	<b>CLEAR THE SELF-LEARNING DATA</b>																				
<p><input checked="" type="checkbox"/> <b>With CONSULT</b></p> <ol style="list-style-type: none"> <li>Start engine and warm it up to normal operating temperature.</li> <li>Select "SELF-LEARNING CONT" in "ACTIVE TEST" mode with CONSULT.</li> <li>Clear the self-learning control coefficient by touching "CLEAR".</li> </ol>																					
<table border="1" style="width: 100%;"> <tr> <td colspan="2" style="text-align: center;"><input checked="" type="checkbox"/> <b>ACTIVE TEST</b> <input type="checkbox"/></td> </tr> <tr> <td>SELF-LEARN CONTROL</td> <td>B1 : 100% B2 : 100%</td> </tr> <tr> <td colspan="2" style="text-align: center;">----- MONITOR -----</td> </tr> <tr> <td>CMPS•RPM(REF)</td> <td>750rpm</td> </tr> <tr> <td>COOLAN TEMP/S</td> <td>93°C</td> </tr> <tr> <td>FR O2 SEN-B1</td> <td>0.90V</td> </tr> <tr> <td>FR O2 SEN-B2</td> <td>0.90V</td> </tr> <tr> <td>A/F ALPHA-B1</td> <td>100%</td> </tr> <tr> <td>A/F ALPHA-B2</td> <td>100%</td> </tr> <tr> <td colspan="2" style="text-align: center;"><b>CLEAR</b></td> </tr> </table>		<input checked="" type="checkbox"/> <b>ACTIVE TEST</b> <input type="checkbox"/>		SELF-LEARN CONTROL	B1 : 100% B2 : 100%	----- MONITOR -----		CMPS•RPM(REF)	750rpm	COOLAN TEMP/S	93°C	FR O2 SEN-B1	0.90V	FR O2 SEN-B2	0.90V	A/F ALPHA-B1	100%	A/F ALPHA-B2	100%	<b>CLEAR</b>	
<input checked="" type="checkbox"/> <b>ACTIVE TEST</b> <input type="checkbox"/>																					
SELF-LEARN CONTROL	B1 : 100% B2 : 100%																				
----- MONITOR -----																					
CMPS•RPM(REF)	750rpm																				
COOLAN TEMP/S	93°C																				
FR O2 SEN-B1	0.90V																				
FR O2 SEN-B2	0.90V																				
A/F ALPHA-B1	100%																				
A/F ALPHA-B2	100%																				
<b>CLEAR</b>																					
SEF921U																					
<ol style="list-style-type: none"> <li>Run engine for at least 10 minutes at idle speed. <b>Is the 1st trip DTC P0171, P0172, P0174 or P0175 detected?</b> <b>Is it difficult to start engine?</b></li> </ol>																					
<p><input checked="" type="checkbox"/> <b>Without CONSULT</b></p> <ol style="list-style-type: none"> <li>Start engine and warm it up to normal operating temperature.</li> <li>Turn ignition switch "OFF".</li> <li>Disconnect mass air flow sensor harness connector, and restart and run engine for at least 5 seconds at idle speed.</li> <li>Stop engine and reconnect mass air flow sensor harness connector.</li> <li>Make sure 1st trip DTC No. 0102 is displayed in Diagnostic Test Mode II.</li> <li>Erase the diagnostic test mode II (Self-diagnostic results) memory. Refer to "HOW TO ERASE EMISSION-RELATED DIAGNOSTIC INFORMATION", EC-55.</li> <li>Make sure DTC No. 0505 is displayed in Diagnostic Test Mode II.</li> <li>Run engine for at least 10 minutes at idle speed. <b>Is the 1st trip DTC 0114, 0115, 0209 or 0210 detected?</b> <b>Is it difficult to start engine?</b></li> </ol>																					
<b>Yes or No</b>																					
Yes	▶ Perform trouble diagnosis for DTC P0171, P0174 or P0172, P0175. Refer to EC-247, 254.																				
No	▶ GO TO 6.																				

GI  
MA  
EM  
LC  
EC  
FE  
CL  
MT  
AT  
TF  
PD  
FA  
RA  
BR  
ST  
RS  
BT  
HA  
EL  
IDX

# DTC P0133 (RIGHT BANK, -B1), P0153 (LEFT BANK, -B2) FRONT HEATED OXYGEN SENSOR (FRONT HO2S) (RESPONSE MONITORING)

Diagnostic Procedure (Cont'd)

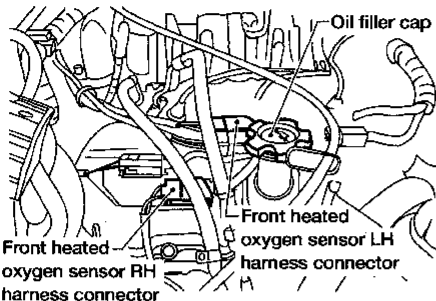
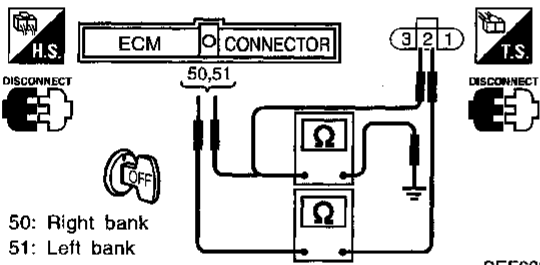
<b>6</b>	<b>CHECK INPUT SIGNAL CIRCUIT</b>														
<ol style="list-style-type: none"> <li>1. Turn ignition switch "OFF".</li> <li>2. Disconnect corresponding front heated oxygen sensor harness connector.</li> </ol>															
															
AEC644A															
<ol style="list-style-type: none"> <li>3. Disconnect ECM harness connector.</li> <li>4. Check harness continuity between ECM terminal and sensor terminal as follows.</li> </ol>															
<table border="1" style="margin: auto; border-collapse: collapse;"> <thead> <tr> <th rowspan="2">DTC</th> <th colspan="2">Terminals</th> <th rowspan="2">Bank</th> </tr> <tr> <th>ECM</th> <th>Sensor</th> </tr> </thead> <tbody> <tr> <td>P0133</td> <td style="text-align: center;">50</td> <td style="text-align: center;">2</td> <td style="text-align: center;">Right</td> </tr> <tr> <td>P0153</td> <td style="text-align: center;">51</td> <td style="text-align: center;">2</td> <td style="text-align: center;">Left</td> </tr> </tbody> </table>		DTC	Terminals		Bank	ECM	Sensor	P0133	50	2	Right	P0153	51	2	Left
DTC	Terminals		Bank												
	ECM	Sensor													
P0133	50	2	Right												
P0153	51	2	Left												
AEC890A															
															
SEF632W															
<p>50: Right bank 51: Left bank</p> <p><b>Continuity should exist.</b></p> <ol style="list-style-type: none"> <li>5. Check harness continuity between ECM terminal or sensor terminal and ground as follows.</li> </ol>															
<table border="1" style="margin: auto; border-collapse: collapse;"> <thead> <tr> <th rowspan="2">DTC</th> <th colspan="2">Terminals</th> <th rowspan="2">Bank</th> </tr> <tr> <th>ECM or sensor</th> <th>Ground</th> </tr> </thead> <tbody> <tr> <td>P0133</td> <td style="text-align: center;">50 or 2</td> <td style="text-align: center;">Ground</td> <td style="text-align: center;">Right</td> </tr> <tr> <td>P0153</td> <td style="text-align: center;">51 or 2</td> <td style="text-align: center;">Ground</td> <td style="text-align: center;">Left</td> </tr> </tbody> </table>		DTC	Terminals		Bank	ECM or sensor	Ground	P0133	50 or 2	Ground	Right	P0153	51 or 2	Ground	Left
DTC	Terminals		Bank												
	ECM or sensor	Ground													
P0133	50 or 2	Ground	Right												
P0153	51 or 2	Ground	Left												
AEC891A															
<p><b>Continuity should not exist.</b></p> <ol style="list-style-type: none"> <li>6. Also check harness for short to power.</li> </ol>															
<b>OK or NG</b>															
OK	▶ GO TO 7.														
NG	▶ Repair open circuit or short to ground or short to power in harness or connectors.														

<b>7</b>	<b>CHECK FRONT HEATED OXYGEN SENSOR HEATER</b>
Refer to "Component Inspection", EC-207.	
<b>OK or NG</b>	
OK	▶ GO TO 8.
NG	▶ Replace malfunctioning front heated oxygen sensor.

<b>8</b>	<b>CHECK MASS AIR FLOW SENSOR</b>
Refer to "Component Inspection", EC-129.	
<b>OK or NG</b>	
OK	▶ GO TO 9.
NG	▶ Replace mass air flow sensor.

<b>9</b>	<b>CHECK PCV VALVE</b>
Refer to "Positive Crankcase Ventilation", EC-30.	
<b>OK or NG</b>	
OK	▶ GO TO 10.
NG	▶ Replace PCV valve.

<b>10</b>	<b>CHECK FRONT HEATED OXYGEN SENSOR</b>
Refer to "Component Inspection", EC-193.	
<b>OK or NG</b>	
OK	▶ GO TO 11.
NG	▶ Replace malfunctioning front heated oxygen sensor.

<b>11</b>	<b>CHECK SHIELD CIRCUIT</b>
<ol style="list-style-type: none"> <li>1. Turn ignition switch "OFF"</li> <li>2. Disconnect joint connector.</li> <li>3. Check the following. <ul style="list-style-type: none"> <li>• Continuity between joint connector terminal and ground</li> <li>• Joint connector</li> </ul>                     (Refer to "HARNES LAYOUT" in EL section.)  <b>Continuity should exist.</b> </li> <li>4. Also check harness for short to ground and short to power.</li> <li>5. Then reconnect joint connector.</li> </ol>	
<b>OK or NG</b>	
OK	▶ GO TO 12.
NG	▶ Repair open circuit or short to ground or short to power in harness or connectors.

<b>12</b>	<b>CHECK INTERMITTENT INCIDENT</b>
Refer to "TROUBLE DIAGNOSIS FOR INTERMITTENT INCIDENT", EC-115.	
▶ <b>INSPECTION END</b>	

# DTC P0133 (RIGHT BANK, -B1), P0153 (LEFT BANK, -B2) FRONT HEATED OXYGEN SENSOR (FRONT HO2S) (RESPONSE MONITORING)

Component Inspection

☆ MONITOR
☆ NO FAIL

CMPS•RPM(REF)	2137rpm
MAS AIR/FL SE	1.96V
COOLAN TEMP/S	84°C
FR O2 SEN-B1	0.37V
FR O2 MNTR-B1	LEAN
INJ PULSE-B1	2.6msec
A/F ALPHA-B1	101%
FR O2 HTR-B1	ON

RECORD

SEF365V

Right bank

cycle | 1 | 2 | 3 | 4 | 5 |

FR O2 MNTR-B1 R-L-R-L-R-L-R-L-R-L-R

Left bank

cycle | 1 | 2 | 3 | 4 | 5 |

FR O2 MNTR-B2 R-L-R-L-R-L-R-L-R-L-R

R means FR O2 MNTR-B1(-B2) indicates RICH  
L means FR O2 MNTR-B1(-B2) indicates LEAN

SEF702W

## Component Inspection FRONT HEATED OXYGEN SENSOR

NEEC0418

NEEC0418S01

### ⓑ With CONSULT

- 1) Start engine and warm it up to normal operating temperature.
- 2) Select "MANU TRIG" and "HI SPEED" in "DATA MONITOR" mode with CONSULT, and select "FR O2 SEN-B1 (-B2)" and "FR O2 MNTR-B1 (-B2)".
- 3) Hold engine speed at 2,000 rpm under no load during the following steps.
- 4) Touch "RECORD" on CONSULT screen.
- 5) Check the following.
  - "FR O2 MNTR-B1 (-B2)" in "DATA MONITOR" mode changes from "RICH" to "LEAN" to "RICH" 5 times in 10 seconds. 5 times (cycles) are counted as shown left:
  - "FR O2 SEN-B1 (-B2)" voltage goes above 0.6V at least once.
  - "FR O2 SEN-B1 (-B2)" voltage goes below 0.3V at least once.
  - "FR O2 SEN-B1 (-B2)" voltage never exceeds 1.0V.

### CAUTION:

**Discard any heated oxygen sensor which has been dropped from a height of more than 0.5 m (19.7 in) onto a hard surface such as a concrete floor; use a new one.**

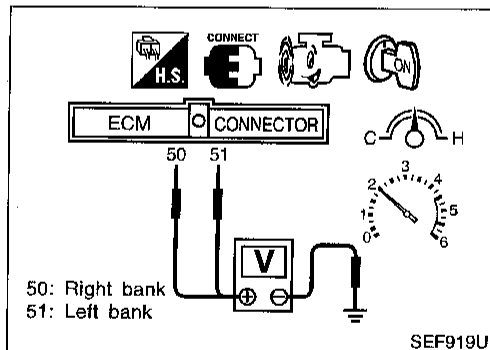
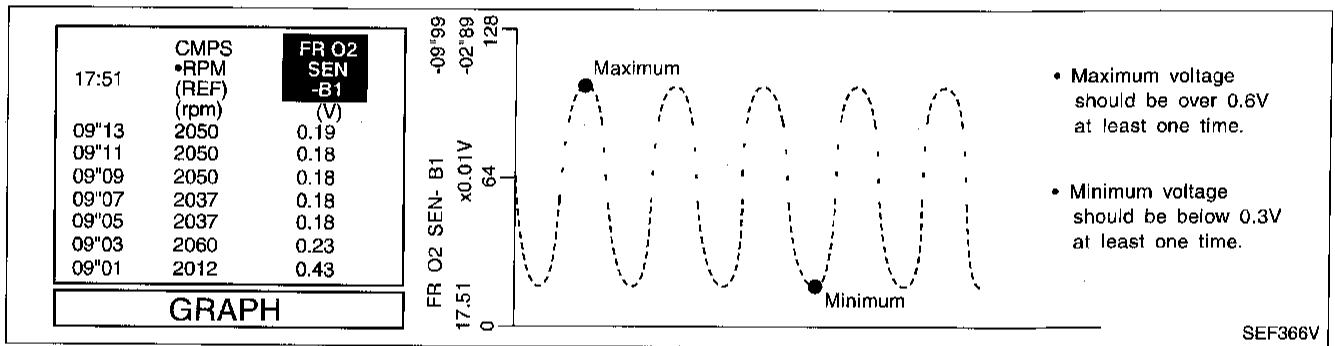

### ⓐ Without CONSULT

- 1) Start engine and warm it up to normal operating temperature.
- 2) Set voltmeter probes between ECM terminal 50 (right bank sensor signal) or 51 (left bank sensor signal) and engine ground.
- 3) Check the following with engine speed held at 2,000 rpm constant under no load.
  - MIL goes on more than 5 times within 10 seconds in Diagnostic Test Mode II (FRONT HEATED OXYGEN SENSOR MONITOR).
  - The maximum voltage is over 0.6V at least one time.
  - The minimum voltage is below 0.3V at least one time.
  - The voltage never exceeds 1.0V.

### CAUTION:

**Discard any heated oxygen sensor which has been dropped from a height of more than 0.5 m (19.7 in) onto a hard surface such as a concrete floor; use a new one.**

# DTC P0134 (RIGHT BANK, -B1), P0154 (LEFT BANK, -B2) FRONT HEATED OXYGEN SENSOR (FRONT HO2S) (HIGH VOLTAGE)

## Component Description

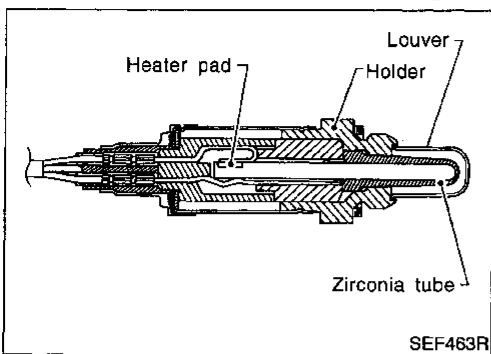

## Component Description

NEEC0419

The front heated oxygen sensor is placed into the front tube. It detects the amount of oxygen in the exhaust gas compared to the outside air. The front heated oxygen sensor has a closed-end tube made of ceramic zirconia. The zirconia generates voltage from approximately 1V in richer conditions to 0V in leaner conditions. The front heated oxygen sensor signal is sent to the ECM. The ECM adjusts the injection pulse duration to achieve the ideal air-fuel ratio. The ideal air-fuel ratio occurs near the radical change from 1V to 0V.

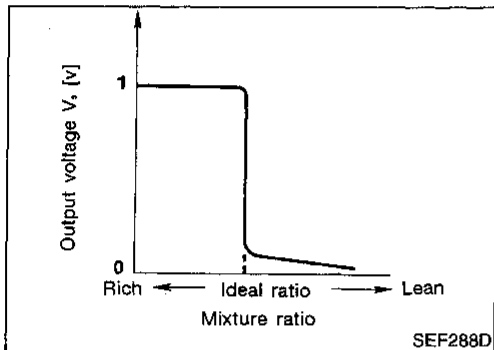

## CONSULT Reference Value in Data Monitor Mode

NEEC0420

Specification data are reference values.

MONITOR ITEM	CONDITION	SPECIFICATION
FR O2 SEN-B1 FR O2 SEN-B2	<ul style="list-style-type: none"> <li>Engine: After warming up</li> </ul> Maintaining engine speed at 2,000 rpm	0 - 0.3V ↔ Approx. 0.6 - 1.0V
FR O2 MNTR-B1 FR O2 MNTR-B2		LEAN ↔ RICH Changes more than 5 times during 10 seconds.

## ECM Terminals and Reference Value

NEEC0421

Specification data are reference values and are measured between each terminal and 32 (ECM ground).

TERMI-NAL NO.	WIRE COLOR	ITEM	CONDITION	DATA (DC Voltage)
50	B	Front heated oxygen sensor RH	[Engine is running] <ul style="list-style-type: none"> <li>After warming up to normal operating temperature and engine speed is 2,000 rpm</li> </ul>	0 - Approximately 1.0V
51	G	Front heated oxygen sensor LH		

SEF002V



# DTC P0134 (RIGHT BANK, -B1), P0154 (LEFT BANK, -B2) FRONT HEATED OXYGEN SENSOR (FRONT HO2S) (HIGH VOLTAGE)

On Board Diagnosis Logic

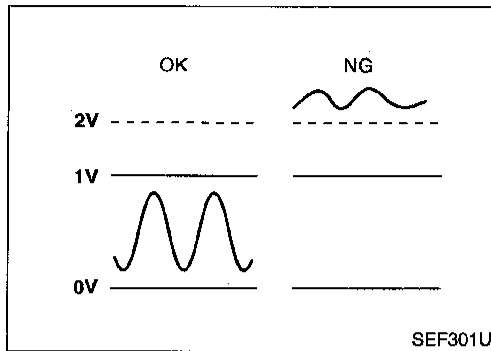

## On Board Diagnosis Logic

To judge the malfunction, the diagnosis checks that the front heated oxygen sensor output is not inordinately high.

NEEC0422

DTC No.	Malfunction is detected when ...	Check Items (Possible Cause)
P0134 0509 (Right bank)	<ul style="list-style-type: none"> <li>An excessively high voltage from the sensor is sent to ECM.</li> </ul>	<ul style="list-style-type: none"> <li>Harness or connectors (The sensor circuit is open or shorted.)</li> <li>Front heated oxygen sensor</li> </ul>
P0154 0412 (Left bank)		

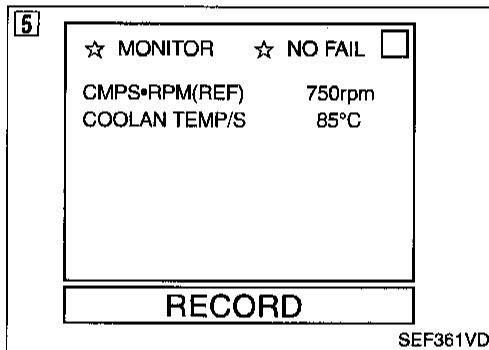

## DTC Confirmation Procedure

NEEC0423

### NOTE:

If "DTC Confirmation Procedure" has been previously conducted, always turn ignition switch "OFF" and wait at least 5 seconds before conducting the next test.

### With CONSULT

- Start engine and warm it up to normal operating temperature.
- Turn ignition switch "OFF" and wait at least 5 seconds.
- Turn ignition switch "ON".
- Select "DATA MONITOR" mode with CONSULT.
- Restart engine and let it idle for 20 seconds.
- If 1st trip DTC is detected, go to "Diagnostic Procedure", EC-199.

### With GST

- Start engine and warm it up to normal operating temperature.
- Turn ignition switch "OFF" and wait at least 5 seconds.
- Restart engine and let it idle for 20 seconds.
- Turn ignition switch "OFF" and wait at least 5 seconds.
- Restart engine and let it idle for 20 seconds.
- Select "MODE 3" with GST.
- If DTC is detected, go to "Diagnostic Procedure", EC-199.

### No Tools

- Start engine and warm it up to normal operating temperature.
- Turn ignition switch "OFF" and wait at least 5 seconds.
- Restart engine and let it idle for 20 seconds.
- Turn ignition switch "OFF", wait at least 5 seconds and then turn "ON".
- Perform "Diagnostic Test Mode II (Self-diagnostic results)" with ECM.
- If 1st trip DTC is detected, go to "Diagnostic Procedure", EC-199.

- When using GST, "DTC Confirmation Procedure" should

**EC-195**

**DTC P0134 (RIGHT BANK, -B1), P0154 (LEFT BANK, -B2) FRONT HEATED  
OXYGEN SENSOR (FRONT HO2S) (HIGH VOLTAGE)**

*DTC Confirmation Procedure (Cont'd)*

---

be performed twice as much as when using CONSULT or ECM (Diagnostic Test Mode II) because GST cannot display MODE 7 (1st trip DTC) concerning this diagnosis. Therefore, using CONSULT or ECM (Diagnostic Test Mode II) is recommended.

# DTC P0134 (RIGHT BANK, -B1), P0154 (LEFT BANK, -B2) FRONT HEATED OXYGEN SENSOR (FRONT HO2S) (HIGH VOLTAGE)

Wiring Diagram

## Wiring Diagram

RIGHT BANK

NEEC0424

NEEC0424S01

EC-FRO2RH-01

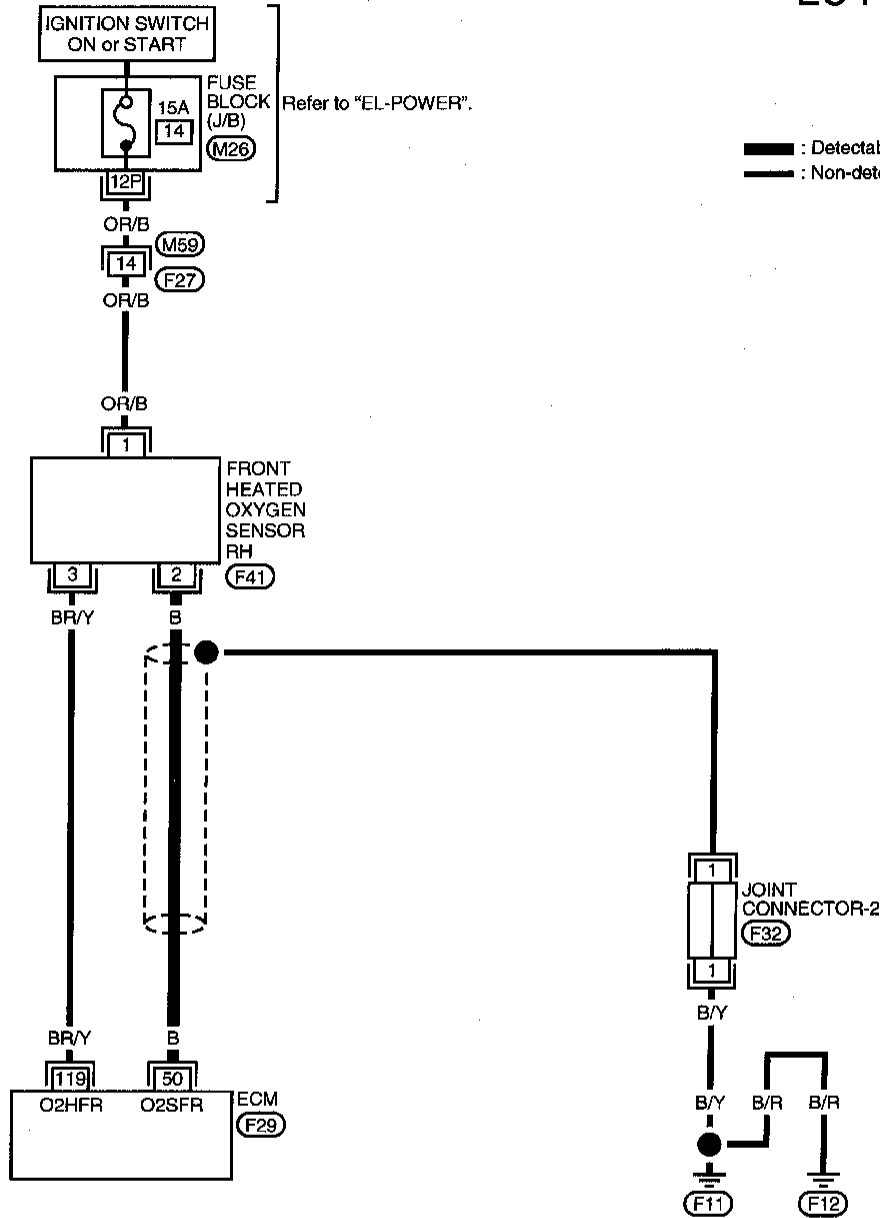

— : Detectable line for DTC  
 - - - : Non-detectable line for DTC

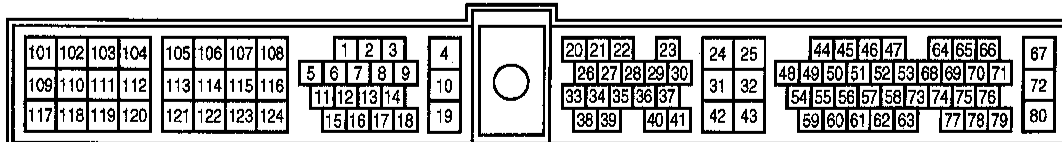
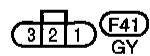
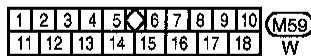
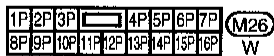

AEC729A

GI  
 MA  
 EM  
 LC  
**EC**  
 FE  
 CL  
 MT  
 AT  
 TF  
 PD  
 FA  
 RA  
 BR  
 ST  
 RS  
 BT  
 HA  
 EL  
 IDX

# DTC P0134 (RIGHT BANK, -B1), P0154 (LEFT BANK, -B2) FRONT HEATED OXYGEN SENSOR (FRONT HO2S) (HIGH VOLTAGE)

Wiring Diagram (Cont'd)

## LEFT BANK

NEEC0424S02

### EC-FRO2LH-01

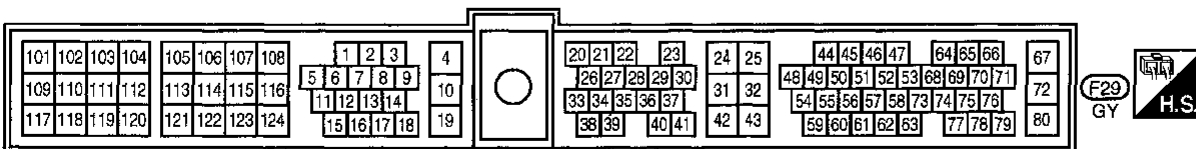
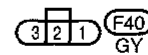
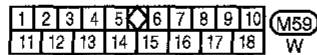
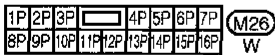
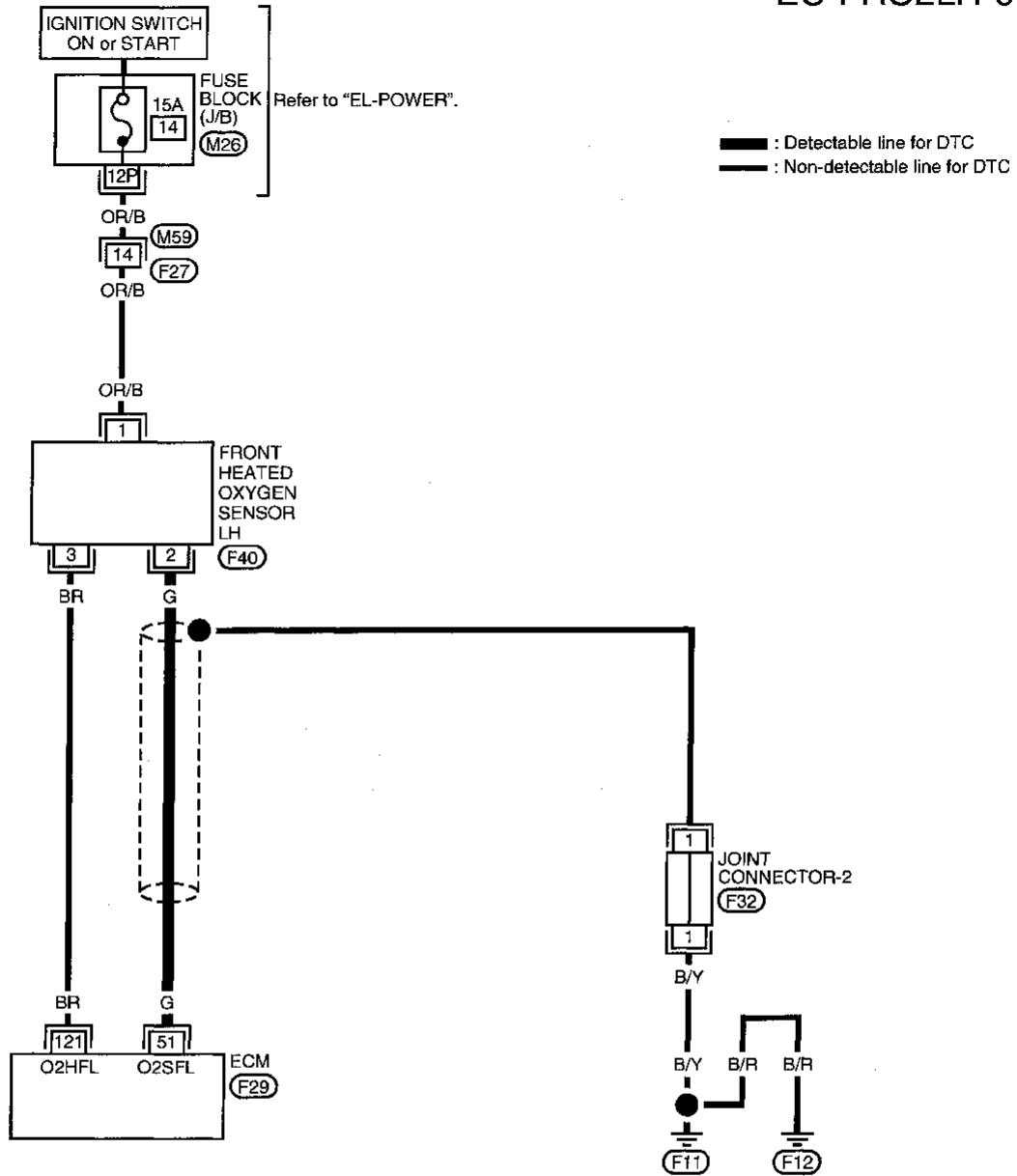

AEC730A

# DTC P0134 (RIGHT BANK, -B1), P0154 (LEFT BANK, -B2) FRONT HEATED OXYGEN SENSOR (FRONT HO2S) (HIGH VOLTAGE)

Diagnostic Procedure

## Diagnostic Procedure

NEEC0425

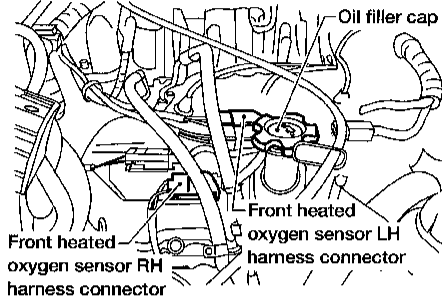
<b>1</b>	<b>INSPECTION START</b>
<ol style="list-style-type: none"> <li>Turn ignition switch "OFF".</li> <li>Disconnect corresponding front heated oxygen sensor harness connector.</li> </ol>	
 <p style="text-align: right;">AEC644A</p>	
▶ GO TO 2.	

<b>2</b>	<b>RETIGHTEN FRONT HEATED OXYGEN SENSOR</b>
<ol style="list-style-type: none"> <li>Loosen and retighten corresponding front heated oxygen sensor.</li> </ol> <p style="text-align: center;"><b>Tightening torque:</b> 40 - 50 N·m (4.1 - 5.1 kg·m, 30 - 37 ft·lb)</p>	
▶ GO TO 3.	

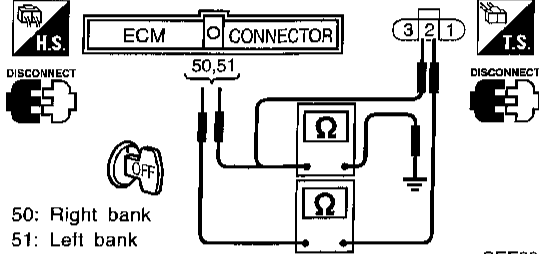
<b>3</b>	<b>CHECK INPUT SIGNAL CIRCUIT</b>														
<ol style="list-style-type: none"> <li>Disconnect ECM harness connector.</li> <li>Check harness continuity between ECM terminal and sensor terminal as follows.</li> </ol>															
<table border="1" style="width: 100%;"> <thead> <tr> <th rowspan="2">DTC</th> <th colspan="2">Terminals</th> <th rowspan="2">Bank</th> </tr> <tr> <th>ECM</th> <th>Sensor</th> </tr> </thead> <tbody> <tr> <td>P0134</td> <td>50</td> <td>2</td> <td>Right</td> </tr> <tr> <td>P0154</td> <td>51</td> <td>2</td> <td>Left</td> </tr> </tbody> </table> <p style="text-align: right;">AEC892A</p>		DTC	Terminals		Bank	ECM	Sensor	P0134	50	2	Right	P0154	51	2	Left
DTC	Terminals		Bank												
	ECM	Sensor													
P0134	50	2	Right												
P0154	51	2	Left												
 <p style="text-align: center;">50: Right bank 51: Left bank</p> <p style="text-align: right;">SEF632W</p>															
<p style="text-align: center;"><b>Continuity should exist.</b></p> <ol style="list-style-type: none"> <li>Check harness continuity between ECM terminal or sensor terminal and ground as follows.</li> </ol>															
<table border="1" style="width: 100%;"> <thead> <tr> <th rowspan="2">DTC</th> <th colspan="2">Terminals</th> <th rowspan="2">Bank</th> </tr> <tr> <th>ECM or sensor</th> <th>Ground</th> </tr> </thead> <tbody> <tr> <td>P0134</td> <td>50 or 2</td> <td>Ground</td> <td>Right</td> </tr> <tr> <td>P0154</td> <td>51 or 2</td> <td>Ground</td> <td>Left</td> </tr> </tbody> </table> <p style="text-align: right;">AEC893A</p>		DTC	Terminals		Bank	ECM or sensor	Ground	P0134	50 or 2	Ground	Right	P0154	51 or 2	Ground	Left
DTC	Terminals		Bank												
	ECM or sensor	Ground													
P0134	50 or 2	Ground	Right												
P0154	51 or 2	Ground	Left												
<p style="text-align: center;"><b>Continuity should not exist.</b></p> <ol style="list-style-type: none"> <li>Also check harness for short to power.</li> </ol>															
<b>OK or NG</b>															
OK	▶	GO TO 4.													
NG	▶	Repair open circuit or short to ground or short to power in harness or connectors.													

<b>4</b>	<b>CHECK CONNECTOR FOR WATER</b>	
<ol style="list-style-type: none"> <li>Disconnect front heated oxygen sensor harness connector.</li> <li>Check connectors for water.</li> </ol> <p><b>Water should not exist.</b></p>		
<b>OK or NG</b>		
OK	▶	GO TO 5.
NG	▶	Repair or replace harness or connectors.

<b>5</b>	<b>CHECK FRONT HEATED OXYGEN SENSOR</b>	
Refer to "Component Inspection", EC-200.		
<b>OK or NG</b>		
OK	▶	GO TO 6.
NG	▶	Replace malfunctioning front heated oxygen sensor.

GI  
MA  
EM  
LC  
EC  
FE  
CL  
MT  
AT  
TF  
PD  
FA  
RA  
BR  
ST  
RS  
BT  
HA  
EL  
IDX

# DTC P0134 (RIGHT BANK, -B1), P0154 (LEFT BANK, -B2) FRONT HEATED OXYGEN SENSOR (FRONT HO2S) (HIGH VOLTAGE)

Diagnostic Procedure (Cont'd)

<b>6</b>	<b>CHECK INTERMITTENT INCIDENT</b>
Refer to "TROUBLE DIAGNOSIS FOR INTERMITTENT INCIDENT", EC-115.	
▶	<b>INSPECTION END</b>

☆ MONITOR	☆ NO FAIL <input type="checkbox"/>
CMPS•RPM(REF)	2137rpm
MAS AIR/FL SE	1.96V
COOLAN TEMP/S	84°C
FR O2 SEN-B1	0.37V
FR O2 MNTR-B1	LEAN
INJ PULSE-B1	2.6msec
A/F ALPHA-B1	101%
FR O2 HTR-B1	ON
<b>RECORD</b>	

SEF365V

Right bank	cycle	1   2   3   4   5
	FR O2 MNTR-B1	R-L-R-L-R-L-R-L-R-L-R
Left bank	cycle	1   2   3   4   5
	FR O2 MNTR-B2	R-L-R-L-R-L-R-L-R-L-R

R means FR O2 MNTR-B1(-B2) indicates RICH  
L means FR O2 MNTR-B1(-B2) indicates LEAN

SEF702W

## Component Inspection FRONT HEATED OXYGEN SENSOR

NEEC0426

NEEC0426S01

### Ⓜ With CONSULT

- 1) Start engine and warm it up to normal operating temperature.
- 2) Select "MANU TRIG" and "HI SPEED" in "DATA MONITOR" mode with CONSULT, and select "FR O2 SEN-B1 (-B2)" and "FR O2 MNTR-B1 (-B2)".
- 3) Hold engine speed at 2,000 rpm under no load during the following steps.
- 4) Touch "RECORD" on CONSULT screen.
- 5) Check the following.
  - "FR O2 MNTR-B1 (-B2)" in "DATA MONITOR" mode changes from "RICH" to "LEAN" to "RICH" 5 times in 10 seconds. 5 times (cycles) are counted as shown left:
  - "FR O2 SEN-B1 (-B2)" voltage goes above 0.6V at least once.
  - "FR O2 SEN-B1 (-B2)" voltage goes below 0.3V at least once.
  - "FR O2 SEN-B1 (-B2)" voltage never exceeds 1.0V.

### CAUTION:

Discard any heated oxygen sensor which has been dropped from a height of more than 0.5 m (19.7 in) onto a hard surface such as a concrete floor; use a new one.

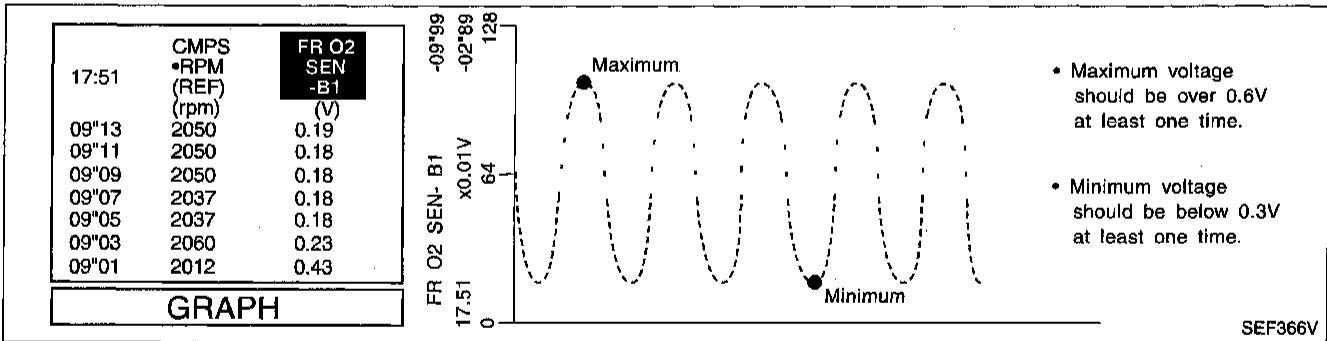

- Maximum voltage should be over 0.6V at least one time.
- Minimum voltage should be below 0.3V at least one time.

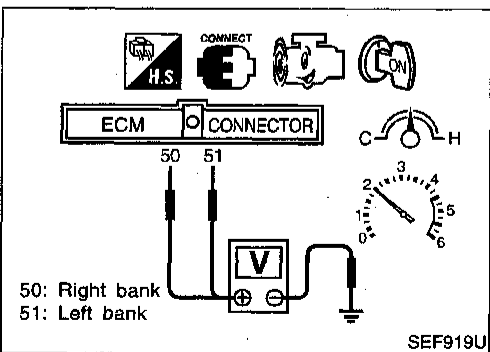

### ⓧ Without CONSULT

- 1) Start engine and warm it up to normal operating temperature.
- 2) Set voltmeter probes between ECM terminal 50 (right bank sensor signal) or 51 (left bank sensor signal) and engine ground.
- 3) Check the following with engine speed held at 2,000 rpm constant under no load.
  - MIL goes on more than 5 times within 10 seconds in Diagnostic Test Mode II (FRONT HEATED OXYGEN SENSOR MONITOR).
  - The maximum voltage is over 0.6V at least one time.

# DTC P0134 (RIGHT BANK, -B1), P0154 (LEFT BANK, -B2) FRONT HEATED OXYGEN SENSOR (FRONT HO2S) (HIGH VOLTAGE)

Component Inspection (Cont'd)

- The minimum voltage is below 0.3V at least one time.
- The voltage never exceeds 1.0V.

## CAUTION:

Discard any heated oxygen sensor which has been dropped from a height of more than 0.5 m (19.7 in) onto a hard surface such as a concrete floor; use a new one.

GI

MA

EM

LC

**EC**

FE

CL

MT

AT

TF

PD

FA

RA

BR

ST

RS

BT

HA

EL

IDX

# DTC P0135 (RIGHT BANK, -B1), P0155 (LEFT BANK, -B2) FRONT HEATED OXYGEN SENSOR HEATER

Description

## Description

### SYSTEM DESCRIPTION

NEEC0427

NEEC0427S01

Sensor	Input Signal to ECM	ECM function	Actuator
Camshaft position sensor	Engine speed	Front heated oxygen sensor heater control	Front heated oxygen sensor heaters

The ECM performs ON/OFF control of the front heated oxygen sensor heaters corresponding to the engine speed.

### OPERATION

NEEC0427S02

Engine speed rpm	Front heated oxygen sensor heaters
Above 3,200	OFF
Below 3,200	ON

## CONSULT Reference Value in Data Monitor Mode

NEEC0428

Specification data are reference values.

MONITOR ITEM	CONDITION	SPECIFICATION
FR O2 HTR-B1 FR O2 HTR-B2	• Engine speed: Below 3,200 rpm	ON
	• Engine speed: Above 3,200 rpm	OFF

## ECM Terminals and Reference Value

NEEC0429

Specification data are reference values and are measured between each terminal and 32 (ECM ground).

TERMI-NAL NO.	WIRE COLOR	ITEM	CONDITION	DATA (DC Voltage)
119 (Right bank)	BR/Y	Front heated oxygen sensor heater	[Engine is running] • Engine speed is below 3,200 rpm	Approximately 0.4V
121 (Left bank)	BR		[Engine is running] • Engine speed is above 3,200 rpm	BATTERY VOLTAGE (11 - 14V)

## On Board Diagnosis Logic

NEEC0430

DTC No.	Malfunction is detected when ...	Check Items (Possible Cause)
P0135 0901 (Right bank)	<ul style="list-style-type: none"> <li>The current amperage in the front heated oxygen sensor heater circuit is out of the normal range. (An improper voltage drop signal is sent to ECM through the front heated oxygen sensor heater.)</li> </ul>	<ul style="list-style-type: none"> <li>Harness or connectors (The front heated oxygen sensor heater circuit is open or shorted.)</li> <li>Front heated oxygen sensor heater</li> </ul>
P0155 1001 (Left bank)		



# DTC P0135 (RIGHT BANK, -B1), P0155 (LEFT BANK, -B2) FRONT HEATED OXYGEN SENSOR HEATER

DTC Confirmation Procedure

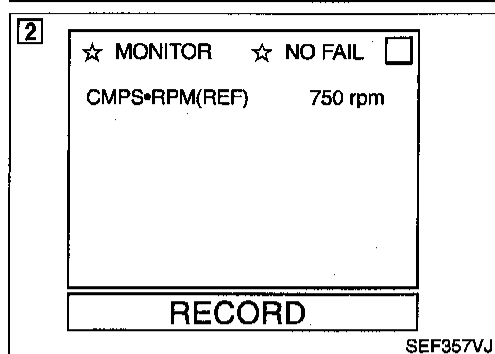

## DTC Confirmation Procedure

NEEC0491

### NOTE:

If "DTC Confirmation Procedure" has been previously conducted, always turn ignition switch "OFF" and wait at least 5 seconds before conducting the next test.

### TESTING CONDITION:

Before performing the following procedure, confirm that battery voltage is between 10.5V and 16V at idle.

#### CONSULT With CONSULT

- 1) Turn ignition switch "ON" and select "DATA MONITOR" mode with CONSULT.
- 2) Start engine and run it for at least 6 seconds at idle speed.
- 3) If 1st trip DTC is detected, go to "Diagnostic Procedure", EC-206.

#### GST With GST

- 1) Start engine and run it for at least 6 seconds at idle speed.
- 2) Turn ignition switch "OFF" and wait at least 5 seconds.
- 3) Start engine and run it for at least 6 seconds at idle speed.
- 4) Select "MODE 3" with GST.
- 5) If DTC is detected, go to "Diagnostic Procedure", EC-206.

#### NO TOOLS No Tools

- 1) Start engine and run it for at least 6 seconds at idle speed.
  - 2) Turn ignition switch "OFF", wait at least 5 seconds and then turn "ON".
  - 3) Perform "Diagnostic Test Mode II (Self-diagnostic results)" with ECM.
  - 4) If 1st trip DTC is detected, go to "Diagnostic Procedure", EC-206.
- When using GST, "DTC Confirmation Procedure" should be performed twice as much as when using CONSULT or ECM (Diagnostic Test Mode II) because GST cannot display MODE 7 (1st trip DTC) concerning this diagnosis. Therefore, using CONSULT or ECM (Diagnostic Test Mode II) is recommended.

GI

MA

EM

LC

EC

FE

CL

MT

AT

TF

PD

FA

RA

BR

ST

RS

BT

HA

EL

IDX

# DTC P0135 (RIGHT BANK, -B1), P0155 (LEFT BANK, -B2) FRONT HEATED OXYGEN SENSOR HEATER

Wiring Diagram

## Wiring Diagram

NEEC0432

NEEC0432S01

### RIGHT BANK

EC-FO2H-R-01

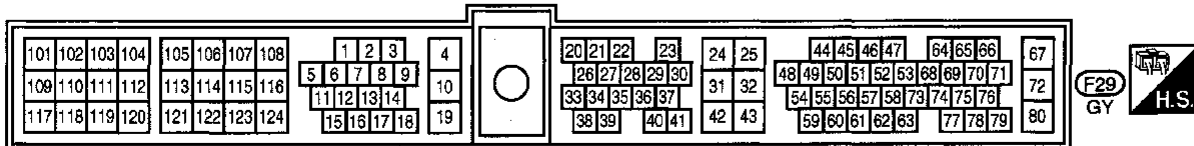
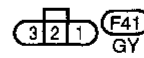
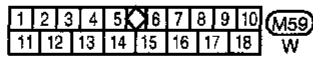
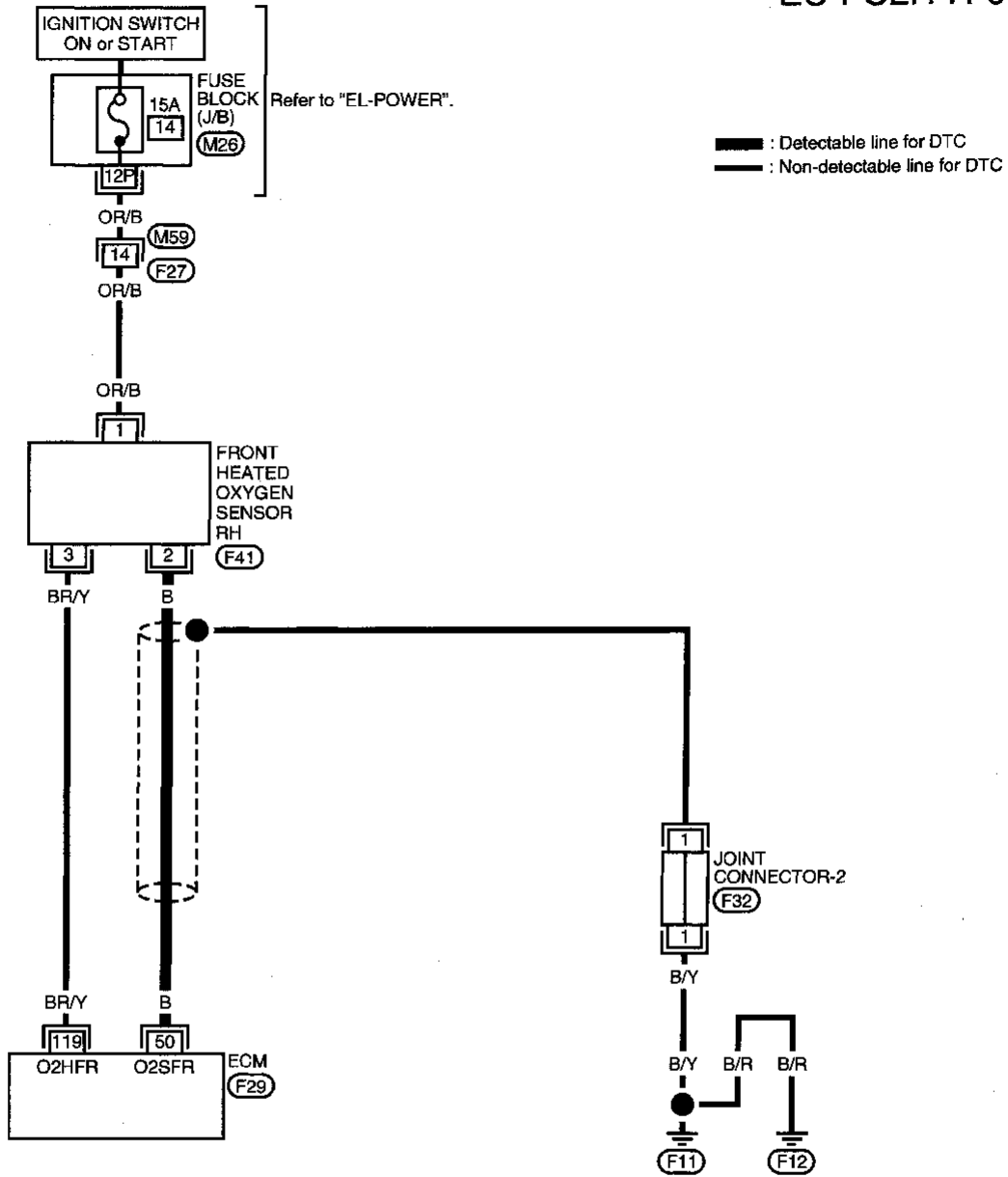

AEC731A

# DTC P0135 (RIGHT BANK, -B1), P0155 (LEFT BANK, -B2) FRONT HEATED OXYGEN SENSOR HEATER

Wiring Diagram (Cont'd)

## LEFT BANK

NEEC0432S02

### EC-FO2H-L-01

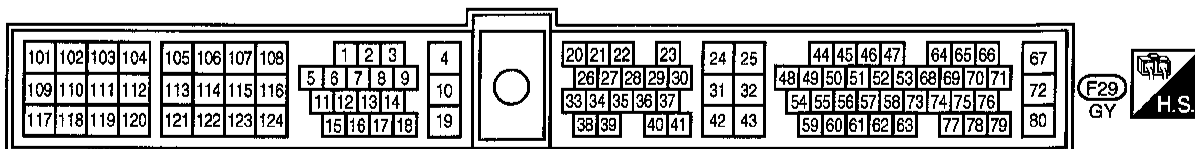
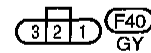
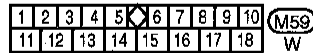
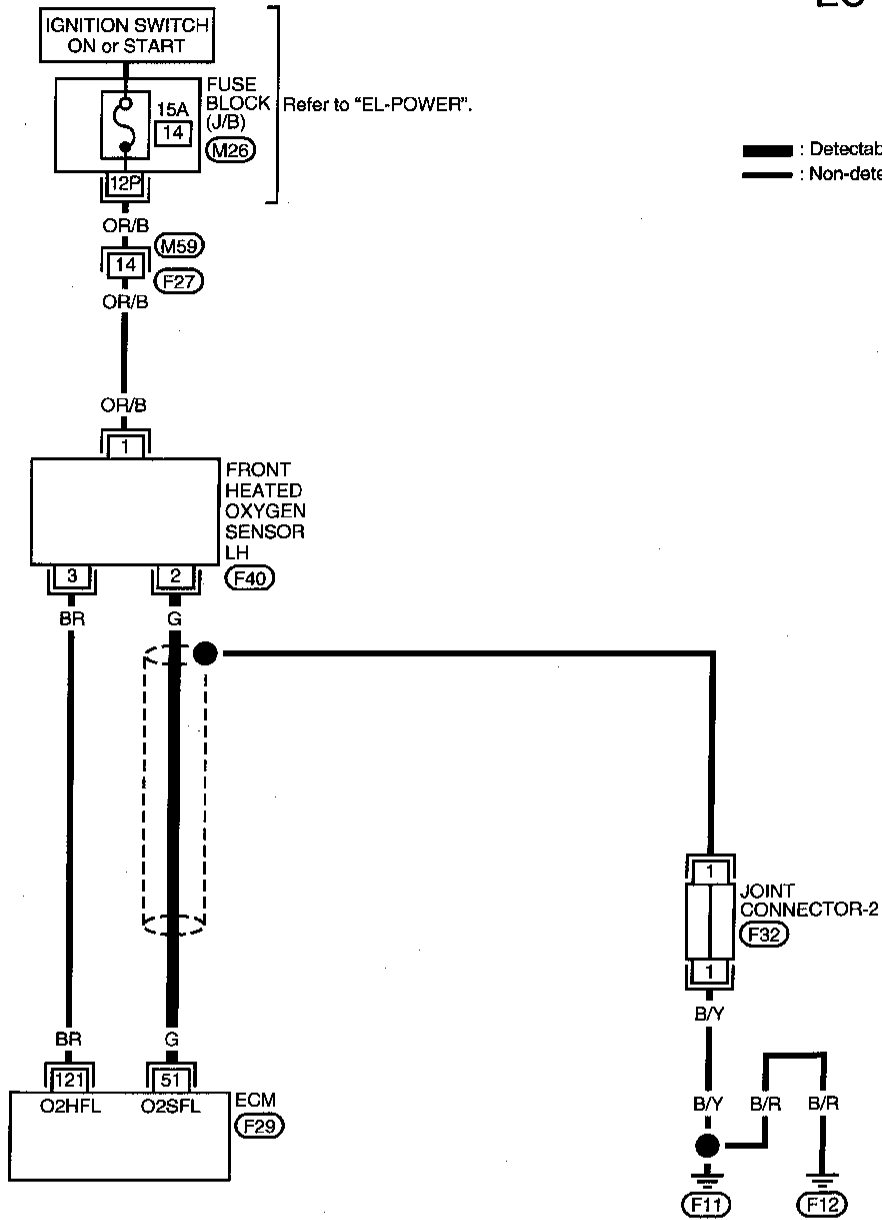

AEC732A

# DTC P0135 (RIGHT BANK, -B1), P0155 (LEFT BANK, -B2) FRONT HEATED OXYGEN SENSOR HEATER

Diagnostic Procedure

NEEC0433

## Diagnostic Procedure

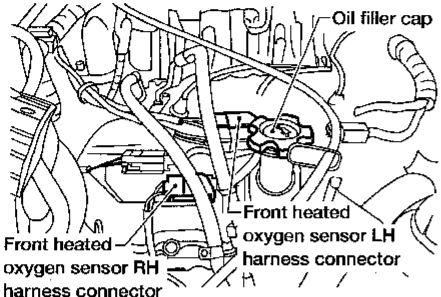
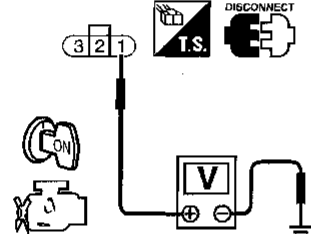
<b>1</b>	<b>CHECK POWER SUPPLY</b>
<ol style="list-style-type: none"> <li>Turn ignition switch "OFF".</li> <li>Disconnect corresponding front heated oxygen sensor harness connector.</li> </ol>	
 <p style="text-align: right;">AEC644A</p>	
<ol style="list-style-type: none"> <li>Turn ignition switch "ON".</li> <li>Check voltage between terminal 1 and ground with CONSULT or tester.</li> </ol>	
 <p style="text-align: right;">SEF633W</p>	
<p><b>Voltage: Battery voltage</b></p> <p><b>OK or NG</b></p>	
OK	▶ GO TO 3.
NG	▶ GO TO 2.

<b>2</b>	<b>DETECT MALFUNCTIONING PART</b>
<p>Check the following.</p> <ul style="list-style-type: none"> <li>Harness connectors M59, F27</li> <li>Fuse block (J/B) connector M26</li> <li>10A fuse</li> <li>Harness for open or short between front heated oxygen sensor and fuse</li> </ul>	
▶ Repair harness or connectors.	

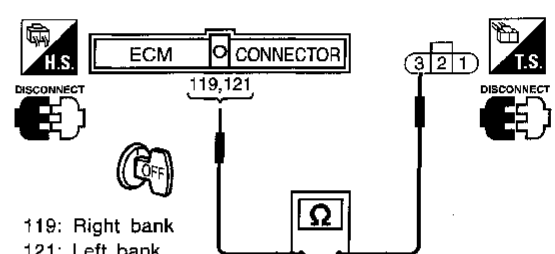
<b>3</b>	<b>CHECK GROUND CIRCUIT</b>														
<ol style="list-style-type: none"> <li>Turn ignition switch "OFF".</li> <li>Disconnect ECM harness connector.</li> <li>Check harness continuity between ECM terminal and sensor terminal as follows.</li> </ol>															
<table border="1" style="width: 100%; text-align: center;"> <thead> <tr> <th rowspan="2">DTC</th> <th colspan="2">Terminals</th> <th rowspan="2">Bank</th> </tr> <tr> <th>ECM</th> <th>Sensor</th> </tr> </thead> <tbody> <tr> <td>P0135</td> <td>119</td> <td>3</td> <td>Right</td> </tr> <tr> <td>P0155</td> <td>121</td> <td>3</td> <td>Left</td> </tr> </tbody> </table> <p style="text-align: right;">AEC894A</p>		DTC	Terminals		Bank	ECM	Sensor	P0135	119	3	Right	P0155	121	3	Left
DTC	Terminals		Bank												
	ECM	Sensor													
P0135	119	3	Right												
P0155	121	3	Left												
 <p style="text-align: right;">SEF634W</p>															
<p><b>Continuity should exist.</b></p>															
<ol style="list-style-type: none"> <li>Also check harness for short to ground and short to power.</li> </ol>															
<b>OK or NG</b>															
OK	▶ GO TO 4.														
NG	▶ Repair open circuit or short to ground or short to power in harness or connectors.														

<b>4</b>	<b>CHECK FRONT HEATED OXYGEN SENSOR HEATER</b>
Refer to "Component Inspection", EC-207.	
<b>OK or NG</b>	
OK	▶ GO TO 5.
NG	▶ Replace malfunctioning front heated oxygen sensor.

<b>5</b>	<b>CHECK INTERMITTENT INCIDENT</b>
Refer to "TROUBLE DIAGNOSIS FOR INTERMITTENT INCIDENT", EC-115.	
▶ INSPECTION END	

# DTC P0135 (RIGHT BANK, -B1), P0155 (LEFT BANK, -B2) FRONT HEATED OXYGEN SENSOR HEATER

Component Inspection

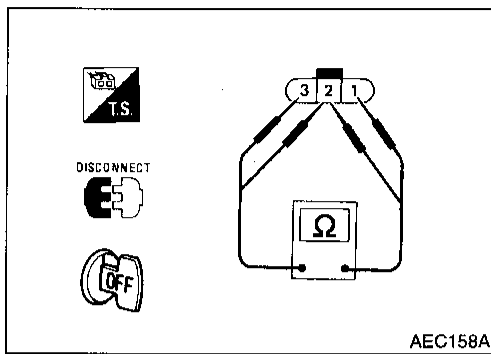

## Component Inspection

### FRONT HEATED OXYGEN SENSOR HEATER

-NEEC0434

NEEC0434S01

Check resistance between terminals 3 and 1.

**Resistance: 2.3 - 4.3Ω at 25°C (77°F)**

Check continuity between terminals 2 and 1, 3 and 2.

**Continuity should not exist.**

If NG, replace the front heated oxygen sensor.

#### CAUTION:

**Discard any heated oxygen sensor which has been dropped from a height of more than 0.5 m (19.7 in) onto a hard surface such as a concrete floor; use a new one.**

GI

MA

EM

LC

**EC**

FE

CL

MT

AT

TF

PD

FA

RA

BR

ST

RS

BT

HA

EL

IDX

# DTC P0137 (RIGHT BANK, -B1), P0157 (LEFT BANK, -B2) REAR HEATED OXYGEN SENSOR (REAR HO2S) (MIN. VOLTAGE MONITORING)

## Component Description

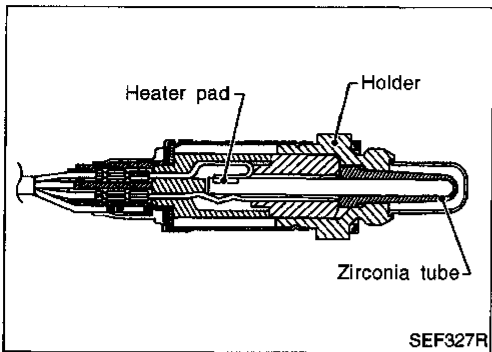

## Component Description

The rear heated oxygen sensor, after three way catalyst, monitors the oxygen level in the exhaust gas on each bank. Even if switching characteristics of the front heated oxygen sensor are shifted, the air fuel ratio is controlled to stoichiometric, by the signal from the rear heated oxygen sensor. This sensor is made of ceramic zirconia. The zirconia generates voltage from approximately 1V in richer conditions to 0V in leaner conditions. Under normal conditions the rear heated oxygen sensor is not used for engine control operation.

NEEC0105

## CONSULT Reference Value in Data Monitor Mode

Specification data are reference values.

NEEC0106

MONITOR ITEM	CONDITION	SPECIFICATION
RR O2 SEN-B1 RR O2 SEN-B2	<ul style="list-style-type: none"> <li>Engine: After warming up</li> </ul> Revving engine from idle up to 2,000 rpm	0 - 0.3V ↔ Approx. 0.6 - 1.0V
RR O2 MNTR-B1 RR O2 MNTR-B2		LEAN ↔ RICH

## ECM Terminals and Reference Value

Specification data are reference values and are measured between each terminal and 32 (ECM ground).

NEEC0107

TERMI-NAL NO.	WIRE COLOR	ITEM	CONDITION	DATA (DC Voltage)
56 (Right bank)	OR	Rear heated oxygen sensor	[Engine is running] <ul style="list-style-type: none"> <li>Warm-up condition</li> <li>Revving engine from idle up to 2,000 rpm</li> </ul>	0 - Approximately 1.0V
57 (Left bank)	Y			

## On Board Diagnosis Logic

The rear heated oxygen sensor has a much longer switching time between rich and lean than the front heated oxygen sensor. The oxygen storage capacity before the three way catalyst causes the longer switching time. To judge the malfunctions of rear heated oxygen sensor, ECM monitors whether the minimum voltage of sensor is sufficiently low during the various driving condition such as fuel-cut.

NEEC0108

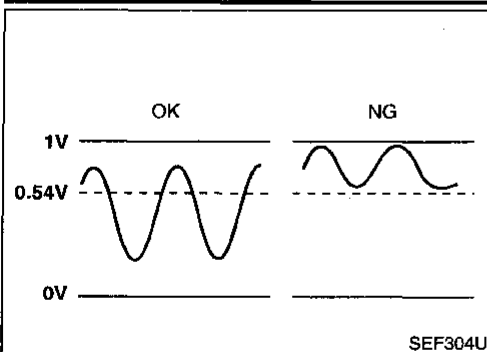

DTC No.	Malfunction is detected when ...	Check Items (Possible Cause)
P0137 0511 (Right bank)	<ul style="list-style-type: none"> <li>The minimum voltage from the sensor is not reached to the specified voltage.</li> </ul>	<ul style="list-style-type: none"> <li>Harness or connectors (The sensor circuit is open or shorted.)</li> <li>Rear heated oxygen sensor</li> <li>Fuel pressure</li> <li>Injectors</li> </ul>
P0157 0314 (Left bank)		

# DTC P0137 (RIGHT BANK, -B1), P0157 (LEFT BANK, -B2) REAR HEATED OXYGEN SENSOR (REAR HO2S) (MIN. VOLTAGE MONITORING)

DTC Confirmation Procedure

NEEC0435

**6**

<p>■ RR O2 SEN-B1 P0137 ■ □</p> <p>COND1: OUT OF COND COND2: INCOMPLETE COND3: INCOMPLETE</p> <p>===== MONITOR =====</p> <p>CMPS-RPM(POS) 925rpm THRTL POS SEN 0.46V B/FUEL SCHDL 1.5msec</p>	<p>■ RR O2 SEN-B2 P0157 ■ □</p> <p>COND1: OUT OF COND COND2: INCOMPLETE COND3: INCOMPLETE</p> <p>===== MONITOR =====</p> <p>CMPS-RPM(POS) 925rpm THRTL POS SEN 0.46V B/FUEL SCHDL 1.5msec</p>
---	---

SEF703W

**8**

<p>■ RR O2 SEN-B1 P0137 ■ □</p> <p>COND1: <b>TESTING</b> COND2: INCOMPLETE COND3: INCOMPLETE</p> <p>===== MONITOR =====</p> <p>CMPS-RPM(POS) 1975rpm THRTL POS SEN 1.10V B/FUEL SCHDL 4.4msec</p>	<p>■ RR O2 SEN-B2 P0157 ■ □</p> <p>COND1: <b>TESTING</b> COND2: INCOMPLETE COND3: INCOMPLETE</p> <p>===== MONITOR =====</p> <p>CMPS-RPM(POS) 1975rpm THRTL POS SEN 1.10V B/FUEL SCHDL 4.4msec</p>
---	---

SEF704W

**8**

<p>■ RR O2 SEN-B1 P0137 ■ □</p> <p>COND1: COMPLETED COND2: INCOMPLETE COND3: INCOMPLETE</p> <p>===== MONITOR =====</p> <p>CMPS-RPM(POS) 1975rpm THRTL POS SEN 1.10V B/FUEL SCHDL 4.4msec</p>	<p>■ RR O2 SEN-B2 P0157 ■ □</p> <p>COND1: COMPLETED COND2: INCOMPLETE COND3: INCOMPLETE</p> <p>===== MONITOR =====</p> <p>CMPS-RPM(POS) 1975rpm THRTL POS SEN 1.10V B/FUEL SCHDL 4.4msec</p>
--	--

SEF705W

**1**

<p>■ RR O2 SEN-B1 P0137 ■ □</p> <p>COND1: COMPLETED COND2: COMPLETED COND3: INCOMPLETE</p> <p>===== MONITOR =====</p> <p>CMPS-RPM(POS) 1050rpm THRTL POS SEN 0.51V B/FUEL SCHDL 1.0msec</p>	<p>■ RR O2 SEN-B2 P0157 ■ □</p> <p>COND1: COMPLETED COND2: COMPLETED COND3: INCOMPLETE</p> <p>===== MONITOR =====</p> <p>CMPS-RPM(POS) 1050rpm THRTL POS SEN 0.51V B/FUEL SCHDL 1.0msec</p>
---	---

SEF706W

## DTC Confirmation Procedure

### CAUTION:

Always drive vehicle at a safe speed.

### TESTING CONDITION:

Never stop engine during this test. If the engine is stopped, reperform this test from step 2 in "Procedure for COND1".

### NOTE:

- If "DTC Confirmation Procedure" has been previously conducted, always turn ignition switch "OFF" and wait at least 5 seconds before conducting the next test.
- "COMPLETED" will appear on CONSULT screen when all tests "COND1", "COND2" and "COND3" are completed.

### With CONSULT

#### Procedure for COND1

- Start engine and warm it up to normal operating temperature.
- Turn ignition switch "OFF" and wait at least 5 seconds.
- Turn ignition switch "ON" and select "RR O2 SEN-B1 (-B2) P0137 (P0157)" of "REAR O2 SENSOR" in "DTC WORK SUPPORT" mode with CONSULT.
- Touch "START".
- Start engine and let it idle for at least 30 seconds.
- Rev engine up to 2,000 rpm 2 or 3 times quickly under no load. If "COMPLETED" appears on CONSULT screen, go to step 2 in "Procedure for COND 3". If "COMPLETED" does not appear on CONSULT screen, go to the following step.
- Drive vehicle at a speed of more than 70 km/h (43 MPH) for 2 consecutive minutes.
- When the following conditions are met, "TESTING" will be displayed at "COND1" on the CONSULT screen. Maintain the conditions continuously until "TESTING" changes to "COMPLETED" (It will take approximately 60 seconds.)

CMPS-RPM (POS)	1,300 - 3,100 rpm
Vehicle speed	64 - 130 km/h (40 - 80 MPH)
B/FUEL SCHDL	0.5 - 6.4 msec
Selector lever	Suitable position

### NOTE:

- If "TESTING" is not displayed after 5 minutes, retry from step 2 in "Procedure for COND 1".
- If "COMPLETED" already appears at "COND2" on CONSULT screen before "Procedure for COND2" is conducted, it is unnecessary to conduct "Procedure for COND2".

#### Procedure for COND2

- While driving, release accelerator pedal completely with "OD" OFF from the above condition (step 8) until "INCOMPLETE" at "COND2" on CONSULT screen has turned to "COMPLETED". (It will take approximately 4 seconds.)

GI

MA

EM

LC

EC

FE

CL

MT

AT

TF

PD

FA

RA

BR

ST

RS

BT

HA

EL

IDX

# DTC P0137 (RIGHT BANK, -B1), P0157 (LEFT BANK, -B2) REAR HEATED OXYGEN SENSOR (REAR HO2S) (MIN. VOLTAGE MONITORING)

DTC Confirmation Procedure (Cont'd)

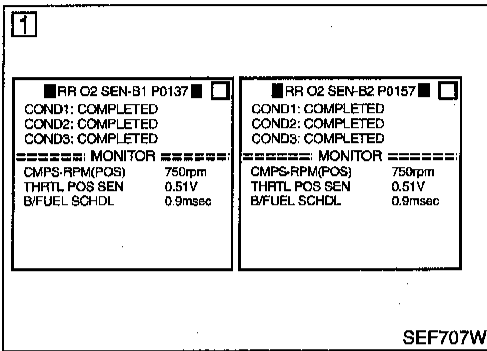

## Procedure for COND3

- 1) Stop vehicle and let it idle until "INCOMPLETE" of "COND3" on CONSULT screen has turned to "COMPLETED". (It will take a maximum of approximately 6 minutes.)
- 2) Make sure that "OK" is displayed after touching "SELF-DIAG RESULTS". If "NG" is displayed, refer to "Diagnostic Procedure", EC-213.

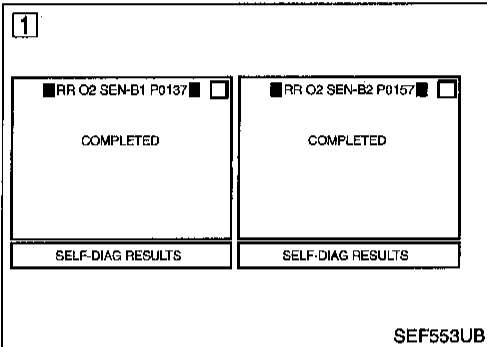

## Overall Function Check

Use this procedure to check the overall function of the rear heated oxygen sensor circuit. During this check, a 1st trip DTC might not be confirmed. NEEC0109

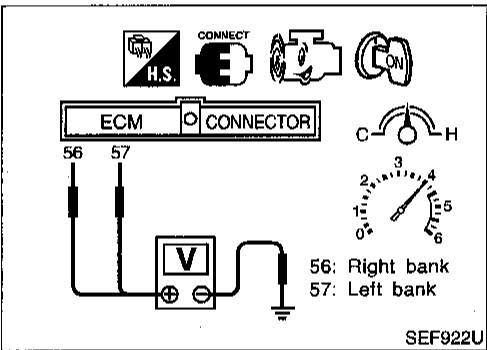

### ⊗ Without CONSULT

- 1) Start engine and drive vehicle at a speed of more than 70 km/h (43 MPH) for 2 consecutive minutes.
- 2) Stop vehicle with engine running.
- 3) Set voltmeter probes between ECM terminal 56 (right bank sensor signal) or 57 (left bank sensor signal) and engine ground.
- 4) Check the voltage when racing up to 4,000 rpm under no load at least 10 times.  
(depress and release accelerator pedal as soon as possible)  
**The voltage should be below 0.54V at least once during this procedure.**  
**If the voltage can be confirmed in step 4, step 5 is not necessary.**
- 5) Keep vehicle at idling for 10 minutes, then check the voltage. Or check the voltage when coasting from 80 km/h (50 MPH) in 3rd gear position (M/T), "D" position with "OD" OFF (A/T).  
**The voltage should be below 0.54V at least once during this procedure.**
- 6) If NG, go to "Diagnostic Procedure", EC-213.



# DTC P0137 (RIGHT BANK, -B1), P0157 (LEFT BANK, -B2) REAR HEATED OXYGEN SENSOR (REAR HO2S) (MIN. VOLTAGE MONITORING)

Wiring Diagram

## Wiring Diagram

RIGHT BANK

NEEC0110

NEEC0110S01

EC-RR02RH-01

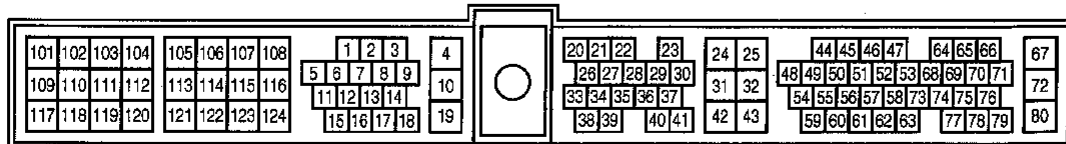
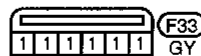
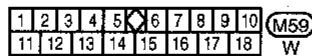
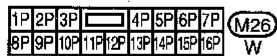
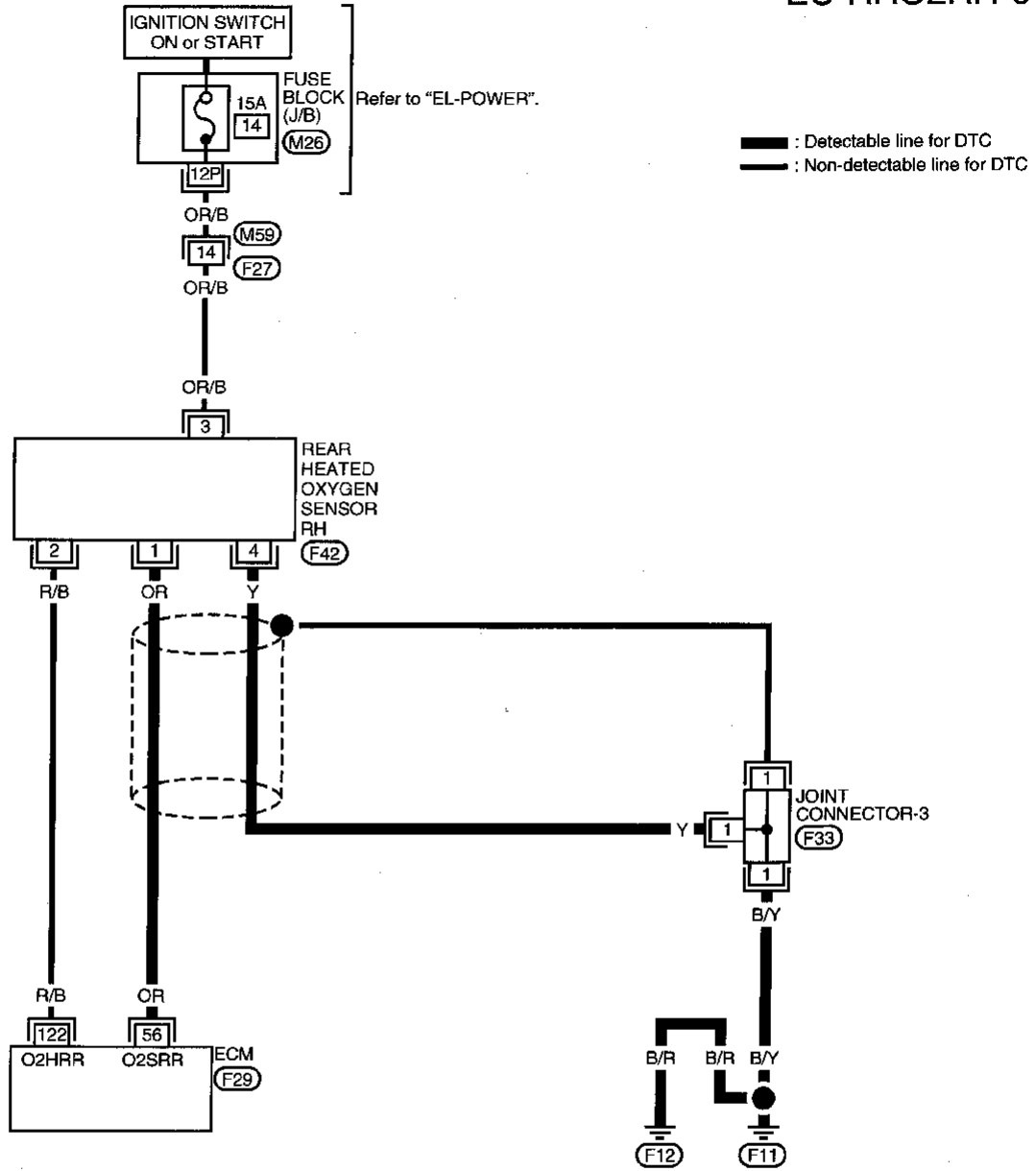

AEC733A

GI  
MA  
EM  
LC  
EC  
FE  
CL  
MT  
AT  
TF  
PD  
FA  
RA  
BR  
ST  
RS  
BT  
HA  
EL  
IDX

# DTC P0137 (RIGHT BANK, -B1), P0157 (LEFT BANK, -B2) REAR HEATED OXYGEN SENSOR (REAR HO2S) (MIN. VOLTAGE MONITORING)

Wiring Diagram (Cont'd)

## LEFT BANK

NEEC0110S02

## EC-RRO2LH-01

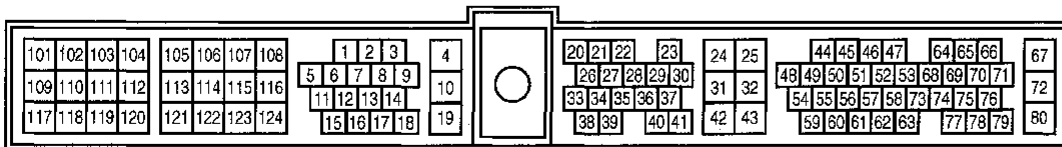
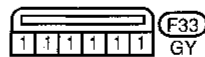
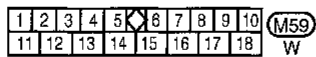
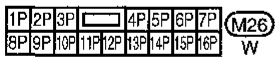
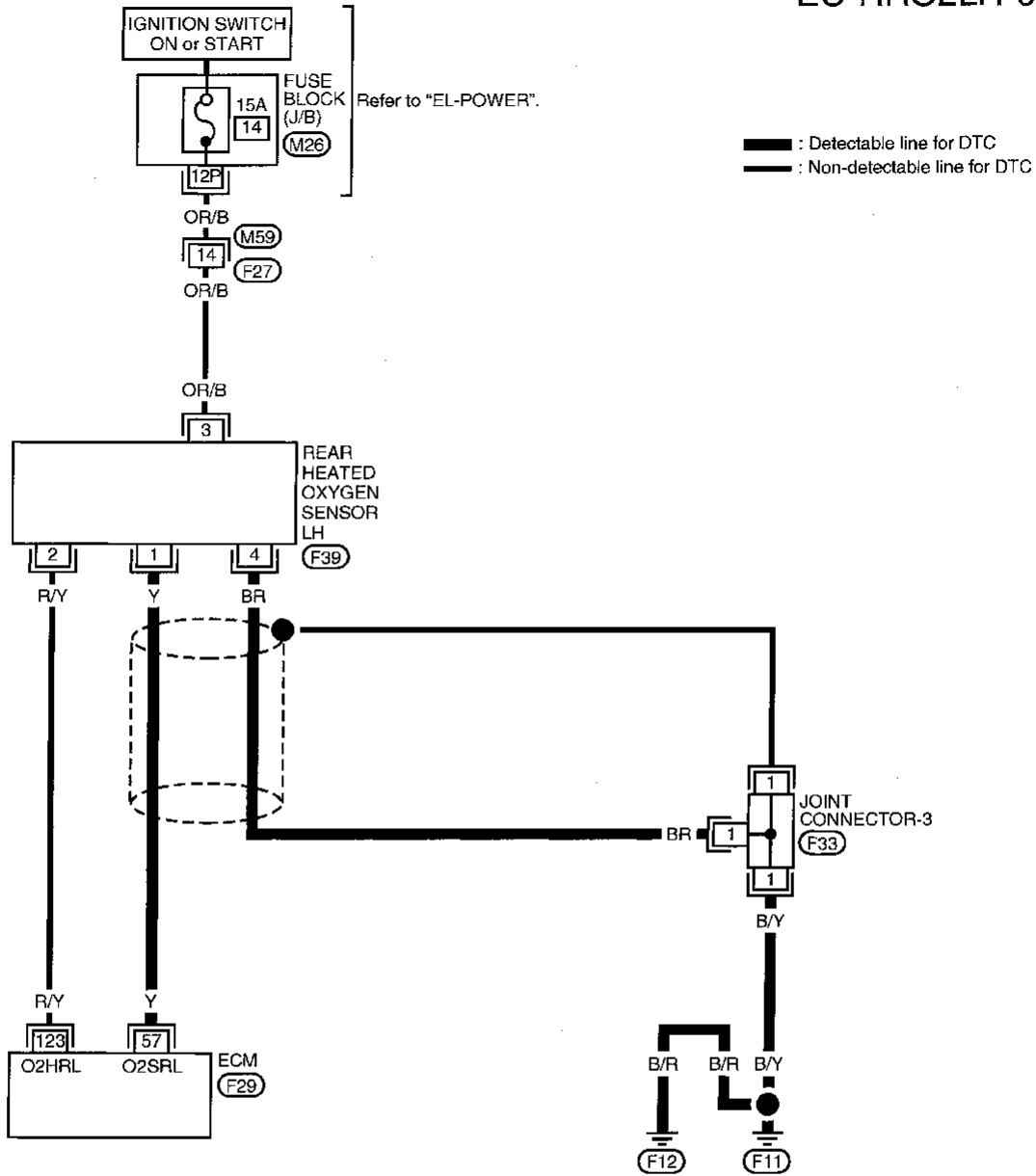

AEC734A

# DTC P0137 (RIGHT BANK, -B1), P0157 (LEFT BANK, -B2) REAR HEATED OXYGEN SENSOR (REAR HO2S) (MIN. VOLTAGE MONITORING)

Diagnostic Procedure

## Diagnostic Procedure

NEEC0111

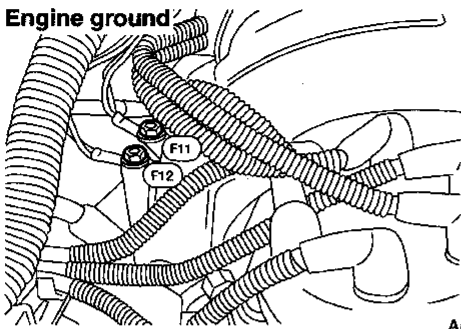
<b>1</b>	<b>RETIGHTEN GROUND SCREWS</b>
<ol style="list-style-type: none"> <li>Turn ignition switch "OFF".</li> <li>Loosen and retighten engine ground screws.</li> </ol>	
 <p style="text-align: right;">AEC640A</p>	
▶ GO TO 2.	

<b>2</b>	<b>CLEAR THE SELF-LEARNING DATA</b>																				
<p><b>Ⓜ With CONSULT</b></p> <ol style="list-style-type: none"> <li>Start engine and warm it up to normal operating temperature.</li> <li>Select "SELF-LEARNING CONT" in "ACTIVE TEST" mode with CONSULT.</li> <li>Clear the self-learning control coefficient by touching "CLEAR".</li> </ol>																					
<table border="1" style="width: 100%;"> <tr> <td colspan="2" style="text-align: center;"><b>■ ACTIVE TEST ■</b></td> </tr> <tr> <td>SELF-LEARN CONTROL</td> <td>B1 : 100% B2 : 100%</td> </tr> <tr> <td colspan="2" style="text-align: center;">===== MONITOR =====</td> </tr> <tr> <td>CMPS•RPM(REF)</td> <td>750rpm</td> </tr> <tr> <td>COOLAN TEMP/S</td> <td>93°C</td> </tr> <tr> <td>FR O2 SEN-B1</td> <td>0.90V</td> </tr> <tr> <td>FR O2 SEN-B2</td> <td>0.90V</td> </tr> <tr> <td>A/F ALPHA-B1</td> <td>100%</td> </tr> <tr> <td>A/F ALPHA-B2</td> <td>100%</td> </tr> <tr> <td colspan="2" style="text-align: center;"><b>CLEAR</b></td> </tr> </table>		<b>■ ACTIVE TEST ■</b>		SELF-LEARN CONTROL	B1 : 100% B2 : 100%	===== MONITOR =====		CMPS•RPM(REF)	750rpm	COOLAN TEMP/S	93°C	FR O2 SEN-B1	0.90V	FR O2 SEN-B2	0.90V	A/F ALPHA-B1	100%	A/F ALPHA-B2	100%	<b>CLEAR</b>	
<b>■ ACTIVE TEST ■</b>																					
SELF-LEARN CONTROL	B1 : 100% B2 : 100%																				
===== MONITOR =====																					
CMPS•RPM(REF)	750rpm																				
COOLAN TEMP/S	93°C																				
FR O2 SEN-B1	0.90V																				
FR O2 SEN-B2	0.90V																				
A/F ALPHA-B1	100%																				
A/F ALPHA-B2	100%																				
<b>CLEAR</b>																					
SEF921U																					
<ol style="list-style-type: none"> <li>Run engine for at least 10 minutes at idle speed. <b>Is the 1st trip DTC P0172 or P0175 detected? Is it difficult to start engine?</b></li> </ol>																					
<p><b>ⓧ Without CONSULT</b></p> <ol style="list-style-type: none"> <li>Start engine and warm it up to normal operating temperature.</li> <li>Turn ignition switch "OFF".</li> <li>Disconnect mass air flow sensor harness connector, and restart and run engine for at least 5 seconds at idle speed.</li> <li>Stop engine and reconnect mass air flow sensor harness connector.</li> <li>Make sure 1st trip DTC No. 0102 is displayed in Diagnostic Test Mode II.</li> <li>Erase the diagnostic test mode II (Self-diagnostic results) memory. Refer to "HOW TO ERASE EMISSION-RELATED DIAGNOSTIC INFORMATION", EC-55.</li> <li>Make sure DTC No. 0505 is displayed in Diagnostic Test Mode II.</li> <li>Run engine for at least 10 minutes at idle speed. <b>Is the 1st trip DTC 0114 or 0209 detected? Is it difficult to start engine?</b></li> </ol>																					
<b>Yes or No</b>																					
Yes	▶ Perform trouble diagnosis for DTC P0172, P0175. Refer to EC-254.																				
No	▶ GO TO 3.																				

GI  
MA  
EM  
LC  
EC  
FE  
CL  
MT  
AT  
TF  
PD  
FA  
RA  
BR  
ST  
RS  
BT  
HA  
EL  
IDX

# DTC P0137 (RIGHT BANK, -B1), P0157 (LEFT BANK, -B2) REAR HEATED OXYGEN SENSOR (REAR HO2S) (MIN. VOLTAGE MONITORING)

Diagnostic Procedure (Cont'd)

## 3 CHECK INPUT SIGNAL CIRCUIT

1. Turn ignition switch "OFF".
2. Disconnect corresponding rear heated oxygen sensor harness connector.

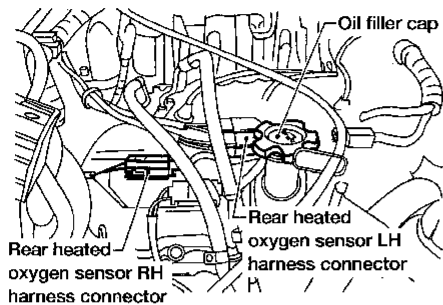

AEC645A

3. Disconnect ECM harness connector.
4. Check harness continuity between ECM terminal and sensor terminal as follows.

DTC	Terminals		Bank
	ECM	Sensor	
P0137	56	1	Right
P0157	57	1	Left

AEC895A

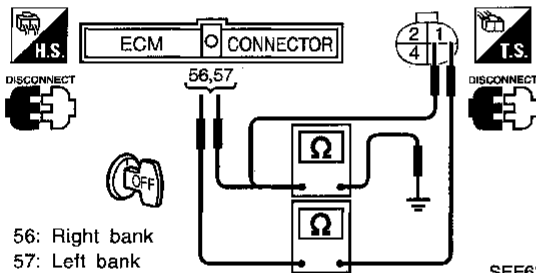

56: Right bank  
57: Left bank

SEF635W

Continuity should exist.

5. Check harness continuity between ECM terminal or sensor terminal and ground as follows.

DTC	Terminals		Bank
	ECM or sensor	Ground	
P0137	56 or 1	Ground	Right
P0157	57 or 1	Ground	Left

AEC896A

Continuity should not exist.

6. Also check harness for short to power.

OK or NG

OK	▶	GO TO 4.
NG	▶	Repair open circuit or short to ground or short to power in harness or connectors.

## 4 CHECK GROUND CIRCUIT

1. Check harness continuity between terminal 4 and engine ground.

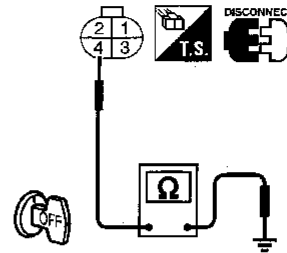

SEF636W

Continuity should exist.

2. Also check harness for short to ground and short to power.

OK or NG

OK	▶	GO TO 6.
NG	▶	GO TO 5.

## 5 DETECT MALFUNCTIONING PART

Check the following.

- Joint connector-3
- Harness for open or short between rear heated oxygen sensor and engine ground.

- ▶ Repair open circuit or short to ground or short to power in harness or connectors.

## 6 CHECK REAR HEATED OXYGEN SENSOR

Refer to "Component Inspection", EC-215.

OK or NG

OK	▶	GO TO 7.
NG	▶	Replace malfunctioning rear heated oxygen sensor.

## 7 CHECK SHIELD CIRCUIT

1. Turn ignition switch "OFF".
2. Disconnect joint connector-3.
3. Check the following.
  - Continuity between joint connector terminal and ground
  - Joint connector (Refer to "HARNESS LAYOUT" in EL section.)

Continuity should exist.

4. Also check harness for short to ground and short to power.
5. Then reconnect joint connector-3.

OK or NG

OK	▶	GO TO 8.
NG	▶	Repair open circuit or short to ground or short to power in harness or connectors.

# DTC P0137 (RIGHT BANK, -B1), P0157 (LEFT BANK, -B2) REAR HEATED OXYGEN SENSOR (REAR HO2S) (MIN. VOLTAGE MONITORING)

Diagnostic Procedure (Cont'd)

<b>8</b>	<b>CHECK INTERMITTENT INCIDENT</b>
Refer to "TROUBLE DIAGNOSIS FOR INTERMITTENT INCIDENT", EC-115.	
▶	<b>INSPECTION END</b>

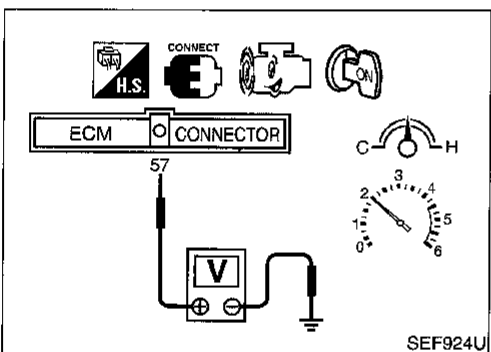
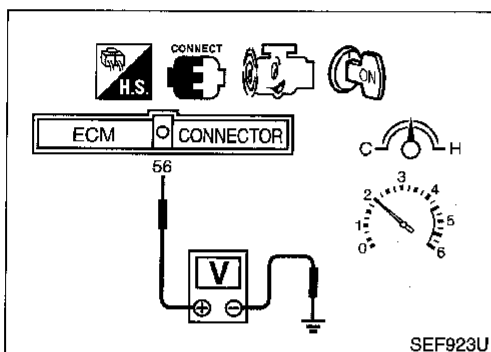

## Component Inspection REAR HEATED OXYGEN SENSOR

NEEC0436

NEEC0436S01

### Ⓜ With CONSULT

- 1) Start engine and drive vehicle at a speed of more than 70 km/h (43 MPH) for 2 consecutive minutes.
- 2) Stop vehicle with engine running.
- 3) Select "FUEL INJECTION" in "ACTIVE TEST" mode, and select "RR O2 SEN-B1 (-B2)" as the monitor item with CONSULT.
- 4) Check "RR O2 SEN-B1 (-B2)" at idle speed when adjusting "FUEL INJECTION" to  $\pm 25\%$ .  
**"RR O2 SEN-B1 (-B2)" should be above 0.56V at least once when the "FUEL INJECTION" is +25%.**  
**"RR O2 SEN-B1 (-B2)" should be below 0.54V at least once when the "FUEL INJECTION" is -25%.**

### Ⓧ Without CONSULT

- 1) Start engine and drive vehicle at a speed of more than 70 km/h (43 MPH) for 2 consecutive minutes.
- 2) Stop vehicle with engine running.
- 3) Set voltmeter probes between ECM terminal 56 (right bank sensor signal) or 57 (left bank sensor signal) engine ground.
- 4) Check the voltage when racing up to 4,000 rpm under no load at least 10 times.  
 (depress and release accelerator pedal as soon as possible)  
**The voltage should be above 0.56V at least once during this procedure.**  
**If the voltage is above 0.56V at step 4, step 5 is not necessary.**
- 5) Keep vehicle at idling for 10 minutes, then check the voltage. Or check the voltage when coasting from 80 km/h (50 MPH) in 3rd gear position (M/T), "D" position with "OD" OFF (A/T).  
**The voltage should be below 0.54V at least once during this procedure.**

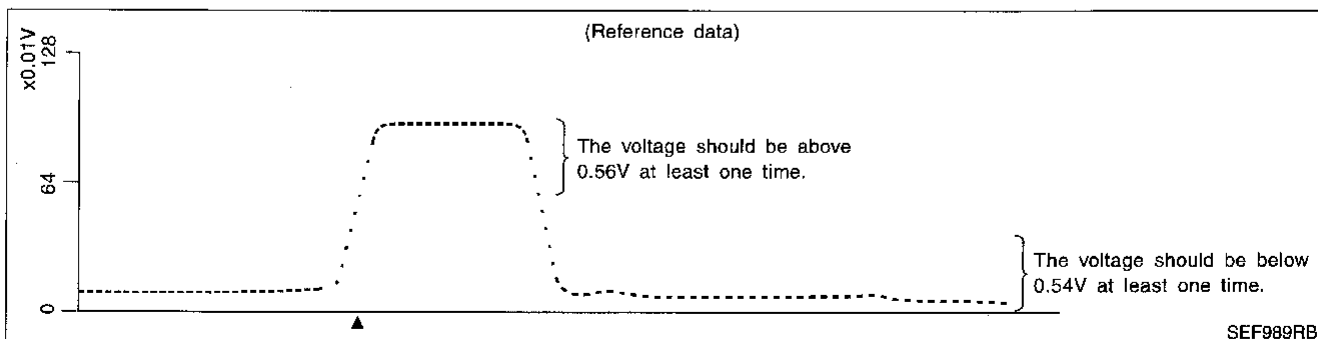

SEF989RB

GI  
MA  
EM  
LC  
EC  
FE  
CL  
MT  
AT  
TF  
PD  
FA  
RA  
BR  
ST  
RS  
BT  
HA  
EL  
IDX

**DTC P0137 (RIGHT BANK, -B1), P0157 (LEFT BANK, -B2) REAR HEATED  
OXYGEN SENSOR (REAR HO2S) (MIN. VOLTAGE MONITORING)**

*Component Inspection (Cont'd)*

---

**CAUTION:**

**Discard any heated oxygen sensor which has been dropped from a height of more than 0.5 m (19.7 in) onto a hard surface such as a concrete floor; use a new one.**

# DTC P0138 (RIGHT BANK, -B1), P0158 (LEFT BANK, -B2) REAR HEATED OXYGEN SENSOR (REAR HO2S) (MAX. VOLTAGE MONITORING)

Component Description

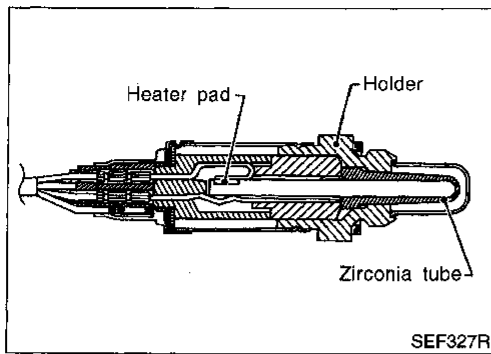

## Component Description

NEEC0497

The rear heated oxygen sensor, after three way catalyst, monitors the oxygen level in the exhaust gas on each bank.

Even if switching characteristics of the front heated oxygen sensor are shifted, the air fuel ratio is controlled to stoichiometric, by the signal from the rear heated oxygen sensor.

This sensor is made of ceramic zirconia. The zirconia generates voltage from approximately 1V in richer conditions to 0V in leaner conditions.

Under normal conditions the rear heated oxygen sensor is not used for engine control operation.

## CONSULT Reference Value in Data Monitor Mode

NEEC0438

Specification data are reference values.

MONITOR ITEM	CONDITION	SPECIFICATION
RR O2 SEN-B1 RR O2 SEN-B2	• Engine: After warming up Revving engine from idle up to 2,000 rpm	0 - 0.3V ↔ Approx. 0.6 - 1.0V
RR O2 MNTR-B1 RR O2 MNTR-B2		LEAN ↔ RICH

## ECM Terminals and Reference Value

NEEC0439

Specification data are reference values and are measured between each terminal and 32 (ECM ground).

TERMI- NAL NO.	WIRE COLOR	ITEM	CONDITION	DATA (DC Voltage)
56 (Right bank)	OR	Rear heated oxygen sensor	[Engine is running] • Warm-up condition • Revving engine from idle up to 2,000 rpm	0 - Approximately 1.0V
57 (Left bank)	Y			

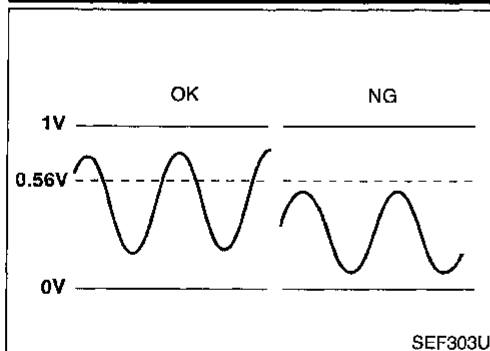

## On Board Diagnosis Logic

NEEC0440

The rear heated oxygen sensor has a much longer switching time between rich and lean than the front heated oxygen sensor. The oxygen storage capacity before the three way catalyst causes the longer switching time. To judge the malfunctions of rear heated oxygen sensor, ECM monitors whether the maximum voltage of the sensor is sufficiently high during the various driving condition such as fuel-cut.

DTC No.	Malfunction is detected when ...	Check Items (Possible Cause)
P0138 0510 (Right bank)	• The maximum voltage from the sensor is not reached to the specified voltage.	<ul style="list-style-type: none"> <li>• Harness or connectors (The sensor circuit is open or shorted.)</li> <li>• Rear heated oxygen sensor</li> <li>• Fuel pressure</li> <li>• Injectors</li> <li>• Intake air leaks</li> </ul>
P0158 0313 (Left bank)		

# DTC P0138 (RIGHT BANK, -B1), P0158 (LEFT BANK, -B2) REAR HEATED OXYGEN SENSOR (REAR HO2S) (MAX. VOLTAGE MONITORING)

## DTC Confirmation Procedure

**6**

<p>■ RR O2 SEN-B1 P0138 ■ □</p> <p>COND1: OUT OF COND COND2: INCOMPLETE COND3: INCOMPLETE</p> <p>===== MONITOR =====</p> <p>CMPS-RPM(POS) 925rpm THRTL POS SEN 0.46V B/FUEL SCHDL 1.5msec</p>	<p>■ RR O2 SEN-B2 P0158 ■ □</p> <p>COND1: OUT OF COND COND2: INCOMPLETE COND3: INCOMPLETE</p> <p>===== MONITOR =====</p> <p>CMPS-RPM(POS) 925rpm THRTL POS SEN 0.46V B/FUEL SCHDL 1.5msec</p>
---	---

SEF708W

**8**

<p>■ RR O2 SEN-B1 P0138 ■ □</p> <p>COND1: TESTING COND2: INCOMPLETE COND3: INCOMPLETE</p> <p>===== MONITOR =====</p> <p>CMPS-RPM(POS) 1975rpm THRTL POS SEN 1.10V B/FUEL SCHDL 4.4msec</p>	<p>■ RR O2 SEN-B2 P0158 ■ □</p> <p>COND1: TESTING COND2: INCOMPLETE COND3: INCOMPLETE</p> <p>===== MONITOR =====</p> <p>CMPS-RPM(POS) 1975rpm THRTL POS SEN 1.10V B/FUEL SCHDL 4.4msec</p>
--	--

SEF709W

**8**

<p>■ RR O2 SEN-B1 P0138 ■ □</p> <p>COND1: COMPLETED COND2: INCOMPLETE COND3: INCOMPLETE</p> <p>===== MONITOR =====</p> <p>CMPS-RPM(POS) 1975rpm THRTL POS SEN 1.10V B/FUEL SCHDL 4.4msec</p>	<p>■ RR O2 SEN-B2 P0158 ■ □</p> <p>COND1: COMPLETED COND2: INCOMPLETE COND3: INCOMPLETE</p> <p>===== MONITOR =====</p> <p>CMPS-RPM(POS) 1975rpm THRTL POS SEN 1.10V B/FUEL SCHDL 4.4msec</p>
--	--

SEF710W

**1**

<p>■ RR O2 SEN-B1 P0138 ■ □</p> <p>COND1: COMPLETED COND2: COMPLETED COND3: INCOMPLETE</p> <p>===== MONITOR =====</p> <p>CMPS-RPM(POS) 1050rpm THRTL POS SEN 0.51V B/FUEL SCHDL 1.0msec</p>	<p>■ RR O2 SEN-B2 P0158 ■ □</p> <p>COND1: COMPLETED COND2: COMPLETED COND3: INCOMPLETE</p> <p>===== MONITOR =====</p> <p>CMPS-RPM(POS) 1050rpm THRTL POS SEN 0.51V B/FUEL SCHDL 1.0msec</p>
---	---

SEF711W

## DTC Confirmation Procedure

NEEC0441

### CAUTION:

Always drive vehicle at a safe speed.

### NOTE:

- "COMPLETED" will appear on CONSULT screen when all tests "COND1", "COND2" and "COND3" are completed.
- If "DTC Confirmation Procedure" has been previously conducted, always turn ignition switch "OFF" and wait at least 5 seconds before conducting the next test.

### TESTING CONDITION:

Never stop engine during this test. If the engine is stopped, reperform this test from step 2 in "Procedure for COND 1".

### Ⓟ With CONSULT

#### Procedure for COND1

- 1) Start engine and warm it up to normal operating temperature.
- 2) Turn ignition switch "OFF" and wait at least 5 seconds.
- 3) Turn ignition switch "ON" and select "RR O2 SEN-B1 (-B2) P0138 (P0158)" of "RR O2 SENSOR" in "DTC WORK SUPPORT" mode with CONSULT.
- 4) Touch "START".
- 5) Start engine and let it idle for at least 30 seconds.
- 6) Rev engine up to 2,000 rpm 2 or 3 times quickly under no load. If "COMPLETED" appears on CONSULT screen, go to step 2 in "Procedure for COND 3". If "COMPLETED" does not appear on CONSULT screen, go to the following step.
- 7) Drive vehicle at a speed of more than 70 km/h (43 MPH) for 2 consecutive minutes.
- 8) When the following conditions are met, "TESTING" will be displayed at "COND1" on the CONSULT screen. Maintain the conditions continuously until "TESTING" changes to "COMPLETED". (It will take approximately 60 seconds.)

CMPS-RPM (POS)	1,300 - 3,100 rpm
Vehicle speed	64 - 130 km/h (40 - 80 MPH)
B/FUEL SCHDL	0.5 - 6.4 msec
Selector lever	Suitable position

### NOTE:

- If "TESTING" is not displayed after 5 minutes, retry from step 2 in "Procedure for COND1".
- If "COMPLETED" already appears at "COND2" on CONSULT screen before "Procedure for COND2" is conducted, it is unnecessary to conduct "Procedure for COND2".

#### Procedure for COND2

- 1) While driving, release accelerator pedal completely with "OD" OFF from the above condition (step 8) until "INCOMPLETE" at "COND2" on CONSULT screen is turned to "COMPLETED". (It will take approximately 4 seconds.)

### NOTE:

If "COMPLETED" already appears at "COND3" on CONSULT screen before "Procedure for COND3" is conducted, it is unnecessary to conduct step 1 in "Procedure for COND3".



# DTC P0138 (RIGHT BANK, -B1), P0158 (LEFT BANK, -B2) REAR HEATED OXYGEN SENSOR (REAR HO2S) (MAX. VOLTAGE MONITORING)

DTC Confirmation Procedure (Cont'd)

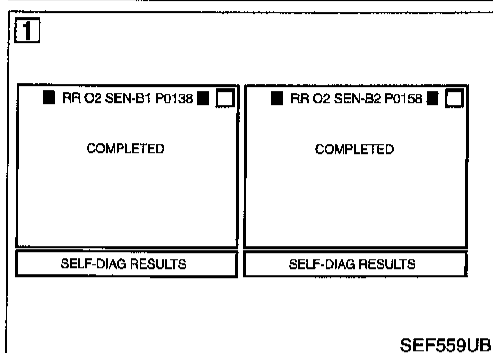

## Procedure for COND3

- 1) Stop vehicle and let it idle until "INCOMPLETE" of "COND3" on CONSULT screen has turned to "COMPLETED". (It will take maximum of approximately 6 minutes.)
- 2) Make sure that "OK" is displayed after touching "SELF-DIAG RESULTS".  
If "NG" is displayed, refer to "Diagnostic Procedure", EC-222.

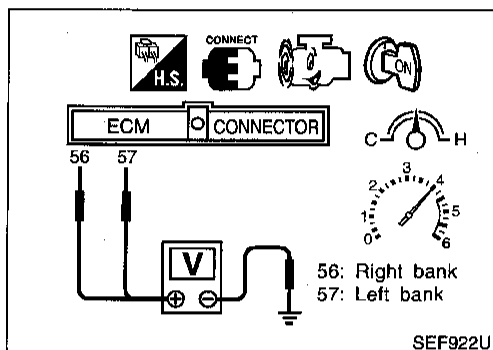

## Overall Function Check

Use this procedure to check the overall function of the rear heated oxygen sensor circuit. During this check, a 1st trip DTC might not be confirmed.

### Without CONSULT

- 1) Start engine and drive vehicle at a speed of more than 70 km/h (43 MPH) for 2 consecutive minutes.
- 2) Stop vehicle with engine running.
- 3) Set voltmeter probes between ECM terminal 56 (right bank sensor signal) or 57 (left bank sensor signal) and engine ground.
- 4) Check the voltage when racing up to 4,000 rpm under no load at least 10 times.  
(depress and release accelerator pedal as soon as possible)  
**The voltage should be above 0.56V at least once during this procedure.**  
**If the voltage can be confirmed in step 4, step 5 is not necessary.**
- 5) Keep vehicle at idling for 10 minutes, then check the voltage. Or check the voltage when coasting from 80 km/h (50 MPH) in 3rd gear position (M/T), "D" position with "OD" OFF (A/T).  
**The voltage should be above 0.56V at least once during this procedure.**
- 6) If NG, go to "Diagnostic Procedure", EC-222.

GI  
MA  
EM  
LC  
EC  
FE  
CL  
MT  
AT  
TF  
PD  
FA  
RA  
BR  
ST  
RS  
BT  
HA  
EL  
IDX

# DTC P0138 (RIGHT BANK, -B1), P0158 (LEFT BANK, -B2) REAR HEATED OXYGEN SENSOR (REAR HO2S) (MAX. VOLTAGE MONITORING)

Wiring Diagram

## Wiring Diagram

NEEC0443

NEEC0443S01

### RIGHT BANK

EC-RR02RH-01

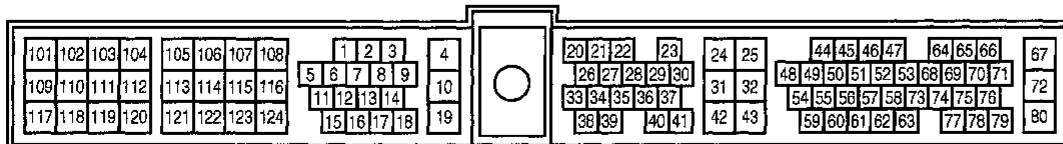
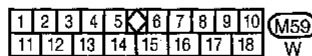
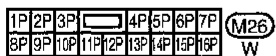
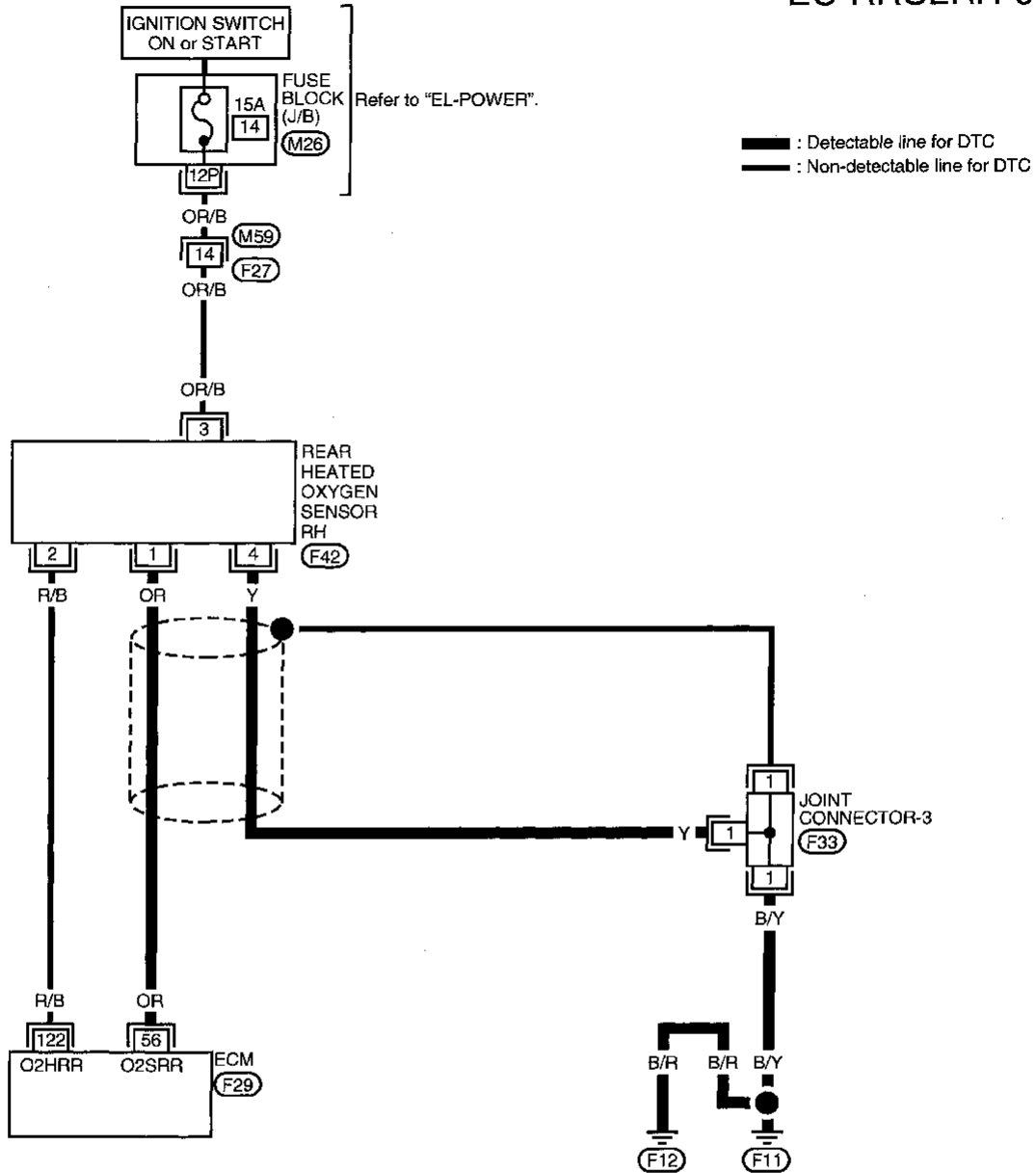

AEC733A

# DTC P0138 (RIGHT BANK, -B1), P0158 (LEFT BANK, -B2) REAR HEATED OXYGEN SENSOR (REAR HO2S) (MAX. VOLTAGE MONITORING)

Wiring Diagram (Cont'd)

## LEFT BANK

NEEC0443S02

### EC-RRO2LH-01

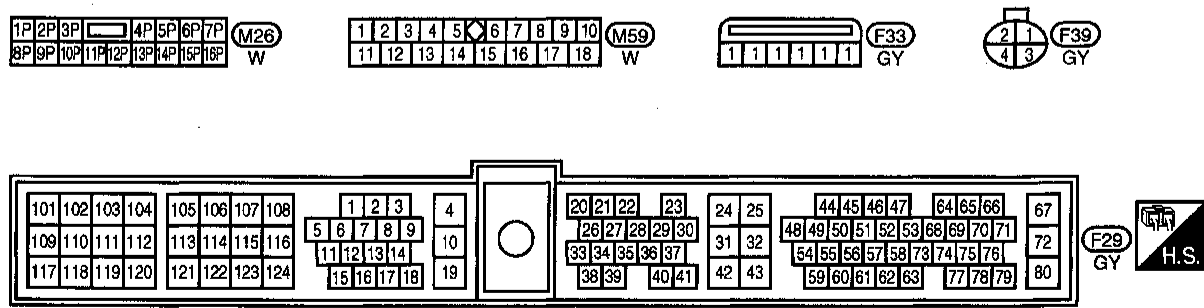
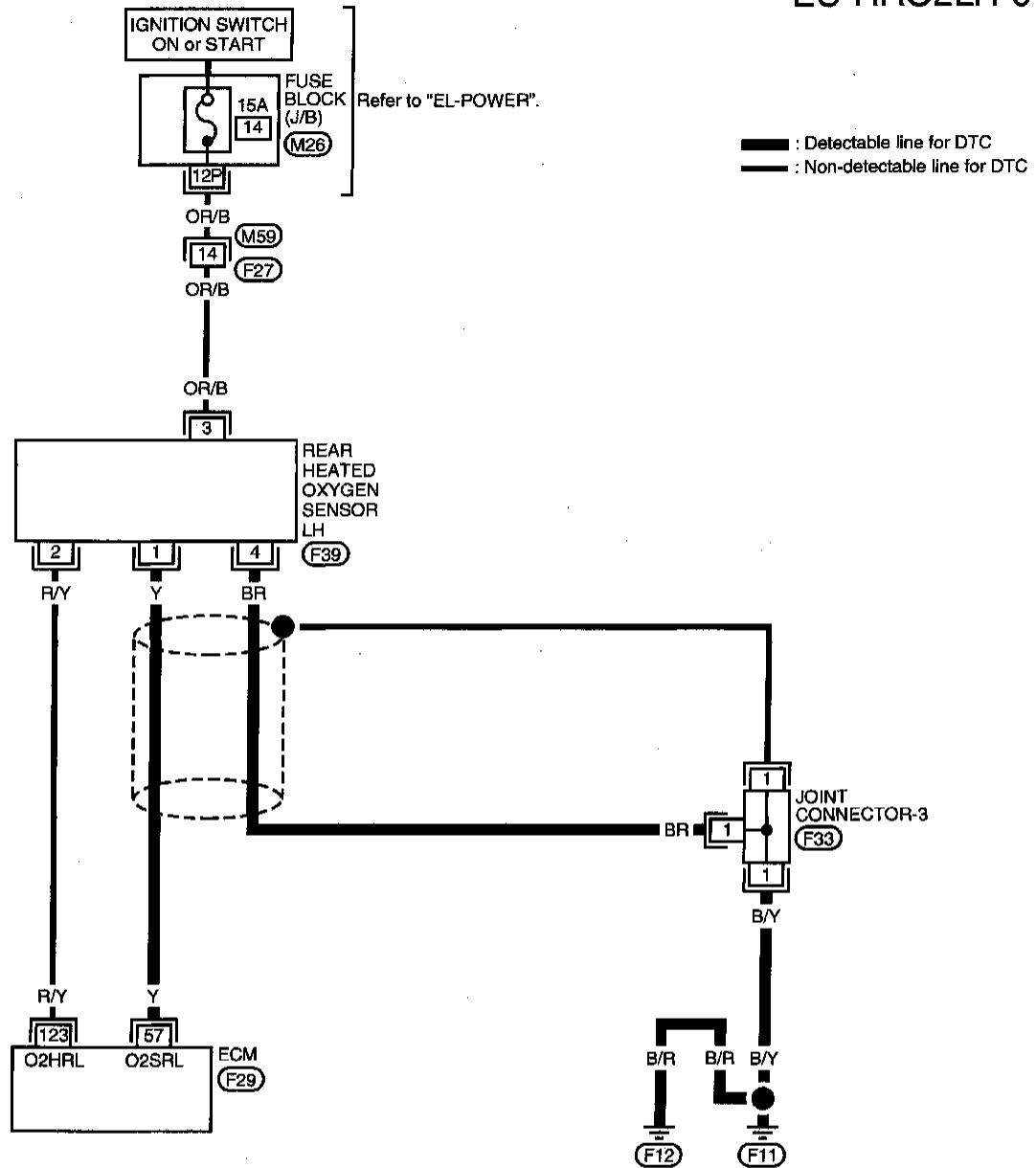

AEC734A



# DTC P0138 (RIGHT BANK, -B1), P0158 (LEFT BANK, -B2) REAR HEATED OXYGEN SENSOR (REAR HO2S) (MAX. VOLTAGE MONITORING)

Diagnostic Procedure

## Diagnostic Procedure

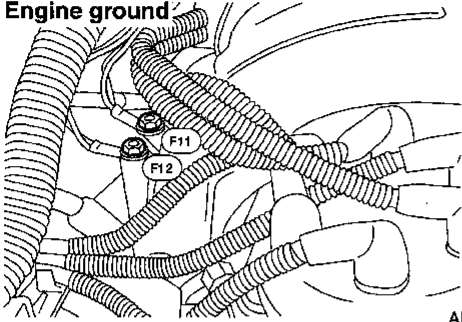
NEEC0444

<b>1</b>	<b>RETIGHTEN GROUND SCREWS</b>
<ol style="list-style-type: none"> <li>1. Turn ignition switch "OFF".</li> <li>2. Loosen and retighten engine ground screws.</li> </ol>	
 <p><b>Engine ground</b></p> <p style="text-align: right;">AEC640A</p>	
<p>▶ GO TO 2.</p>	

<b>2</b>	<b>CLEAR THE SELF-LEARNING DATA</b>																						
<p> <b>With CONSULT</b></p> <ol style="list-style-type: none"> <li>1. Start engine and warm it up to normal operating temperature.</li> <li>2. Select "SELF-LEARNING CONT" in "ACTIVE TEST" mode with CONSULT.</li> <li>3. Clear the self-learning control coefficient by touching "CLEAR".</li> </ol>																							
<table border="1" style="width: 100%;"> <tr> <td colspan="2" style="text-align: center;"><b>ACTIVE TEST</b></td> </tr> <tr> <td>SELF-LEARN</td> <td>B1 : 100%</td> </tr> <tr> <td>CONTROL</td> <td>B2 : 100%</td> </tr> <tr> <td colspan="2" style="text-align: center;">===== MONITOR =====</td> </tr> <tr> <td>CMPS•RPM(REF)</td> <td>750rpm</td> </tr> <tr> <td>COOLAN TEMP/S</td> <td>93°C</td> </tr> <tr> <td>FR O2 SEN-B1</td> <td>0.90V</td> </tr> <tr> <td>FR O2 SEN-B2</td> <td>0.90V</td> </tr> <tr> <td>A/F ALPHA-B1</td> <td>100%</td> </tr> <tr> <td>A/F ALPHA-B2</td> <td>100%</td> </tr> <tr> <td colspan="2" style="text-align: center;"><b>CLEAR</b></td> </tr> </table>		<b>ACTIVE TEST</b>		SELF-LEARN	B1 : 100%	CONTROL	B2 : 100%	===== MONITOR =====		CMPS•RPM(REF)	750rpm	COOLAN TEMP/S	93°C	FR O2 SEN-B1	0.90V	FR O2 SEN-B2	0.90V	A/F ALPHA-B1	100%	A/F ALPHA-B2	100%	<b>CLEAR</b>	
<b>ACTIVE TEST</b>																							
SELF-LEARN	B1 : 100%																						
CONTROL	B2 : 100%																						
===== MONITOR =====																							
CMPS•RPM(REF)	750rpm																						
COOLAN TEMP/S	93°C																						
FR O2 SEN-B1	0.90V																						
FR O2 SEN-B2	0.90V																						
A/F ALPHA-B1	100%																						
A/F ALPHA-B2	100%																						
<b>CLEAR</b>																							
<p>4. Run engine for at least 10 minutes at idle speed.  <b>Is the 1st trip DTC P0171 or P0174 detected?</b>  <b>Is it difficult to start engine?</b></p> <p style="text-align: right;">SEF921U</p>																							
<p> <b>Without CONSULT</b></p> <ol style="list-style-type: none"> <li>1. Start engine and warm it up to normal operating temperature.</li> <li>2. Turn ignition switch "OFF".</li> <li>3. Disconnect mass air flow sensor harness connector, and restart and run engine for at least 5 seconds at idle speed.</li> <li>4. Stop engine and reconnect mass air flow sensor harness connector.</li> <li>5. Make sure 1st trip DTC No. 0102 is displayed in Diagnostic Test Mode II.</li> <li>6. Erase the diagnostic test mode II (Self-diagnostic results) memory. Refer to "HOW TO ERASE EMISSION-RELATED DIAGNOSTIC INFORMATION", EC-55.</li> <li>7. Make sure DTC No. 0505 is displayed in Diagnostic Test Mode II.</li> <li>8. Run engine for at least 10 minutes at idle speed.  <b>Is the 1st trip DTC 0115 or 0210 detected?</b>  <b>Is it difficult to start engine?</b></li> </ol> <p style="text-align: center;"><b>Yes or No</b></p>																							
Yes	▶ Perform trouble diagnosis for DTC P0171, P0174. Refer to EC-247.																						
No	▶ GO TO 3.																						

# DTC P0138 (RIGHT BANK, -B1), P0158 (LEFT BANK, -B2) REAR HEATED OXYGEN SENSOR (REAR HO2S) (MAX. VOLTAGE MONITORING)

Diagnostic Procedure (Cont'd)

**3 CHECK INPUT SIGNAL CIRCUIT**

1. Turn ignition switch "OFF".
2. Disconnect corresponding rear heated oxygen sensor harness connector.
3. Disconnect ECM harness connector.
4. Check harness continuity between ECM terminal and sensor terminal as follows.

DTC	Terminals		Bank
	ECM	Sensor	
P0138	56	1	Right
P0158	57	1	Left

AEC897A

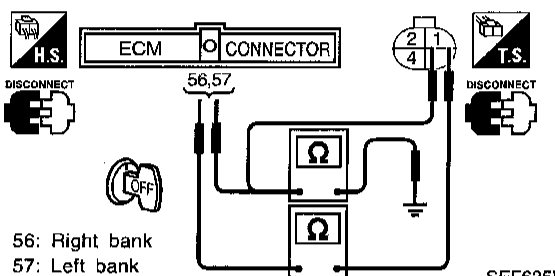

SEF635W

56: Right bank  
57: Left bank

**Continuity should exist.**

5. Check harness continuity between ECM terminal or sensor terminal and ground as follows.

DTC	Terminals		Bank
	ECM or sensor	Ground	
P0138	56 or 1	Ground	Right
P0158	57 or 1	Ground	Left

AEC898A

**Continuity should not exist.**

6. Also check harness for short to power.

OK or NG	
OK	▶ GO TO 4.
NG	▶ Repair open circuit or short to ground or short to power in harness or connectors.

**4 CHECK GROUND CIRCUIT**

1. Check harness continuity between terminal 4 and engine ground.

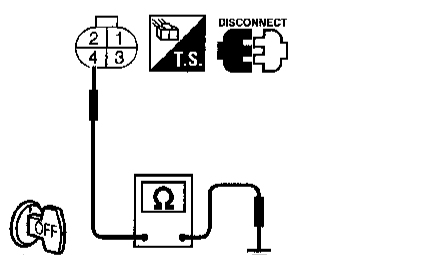

SEF636W

**Continuity should exist.**

2. Also check harness for short to ground and short to power.

OK or NG	
OK	▶ GO TO 6.
NG	▶ GO TO 5.

**5 DETECT MALFUNCTIONING PART**

Check the following.

- Joint connector-3
- Harness for open or short between rear heated oxygen sensor and engine ground.

	▶ Repair open circuit or short to ground or short to power in harness or connectors.
--	--

**6 CHECK REAR HEATED OXYGEN SENSOR**

Refer to "Component Inspection", EC-224.

**OK or NG**

OK	▶ GO TO 7.
NG	▶ Replace malfunctioning rear heated oxygen sensor.

**7 CHECK SHIELD CIRCUIT**

1. Turn ignition switch "OFF".
2. Disconnect joint connector.
3. Check the following.
  - Continuity between joint connector terminal and ground
  - Joint connector

(Refer to "HARNESS LAYOUT" in EL section.)

**Continuity should exist.**
4. Also check harness for short to ground and short to power.
5. Then reconnect joint connector.

**OK or NG**

OK	▶ GO TO 8.
NG	▶ Repair open circuit or short to ground or short to power in harness or connectors.

**8 CHECK INTERMITTENT INCIDENT**

Refer to "TROUBLE DIAGNOSIS FOR INTERMITTENT INCIDENT", EC-115.

	▶ <b>INSPECTION END</b>
--	-------------------------

GI  
MA  
EM  
LC  
EC  
FE  
CL  
MT  
AT  
TF  
PD  
FA  
RA  
BR  
ST  
RS  
BT  
HA  
EL  
DX

# DTC P0138 (RIGHT BANK, -B1), P0158 (LEFT BANK, -B2) REAR HEATED OXYGEN SENSOR (REAR HO2S) (MAX. VOLTAGE MONITORING)

## Component Inspection

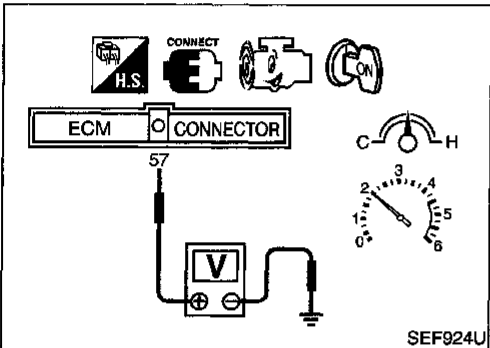
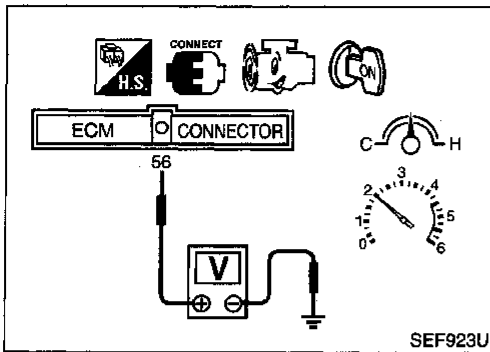

## Component Inspection REAR HEATED OXYGEN SENSOR

NEEC0445

NEEC0445S01

### Ⓐ With CONSULT

- 1) Start engine and drive vehicle at a speed of more than 70 km/h (43 MPH) for 2 consecutive minutes.
- 2) Stop vehicle with engine running.
- 3) Select "FUEL INJECTION" in "ACTIVE TEST" mode, and select "RR O2 SEN-B1 (-B2)" as the monitor item with CONSULT.
- 4) Check "RR O2 SEN-B1 (-B2)" at idle speed when adjusting "FUEL INJECTION" to  $\pm 25\%$ .  
 "RR O2 SEN-B1 (-B2)" should be above 0.56V at least once when the "FUEL INJECTION" is +25%.  
 "RR O2 SEN-B1 (-B2)" should be below 0.54V at least once when the "FUEL INJECTION" is -25%.

### Ⓑ Without CONSULT

- 1) Start engine and drive vehicle at a speed of more than 70 km/h (43 MPH) for 2 consecutive minutes.
- 2) Stop vehicle with engine running.
- 3) Set voltmeter probes between ECM terminal 56 (right bank sensor signal) or 57 (left bank sensor signal) and engine ground.
- 4) Check the voltage when racing up to 4,000 rpm under no load at least 10 times.  
 (depress and release accelerator pedal as soon as possible)  
**The voltage should be above 0.56V at least once during this procedure.**  
**If the voltage is above 0.56V at step 4, step 5 is not necessary.**
- 5) Keep vehicle at idling for 10 minutes, then check the voltage. Or check the voltage when coasting from 80 km/h (50 MPH) in 3rd gear position (M/T), "D" position with "OD" OFF (A/T).  
**The voltage should be below 0.54V at least once during this procedure.**

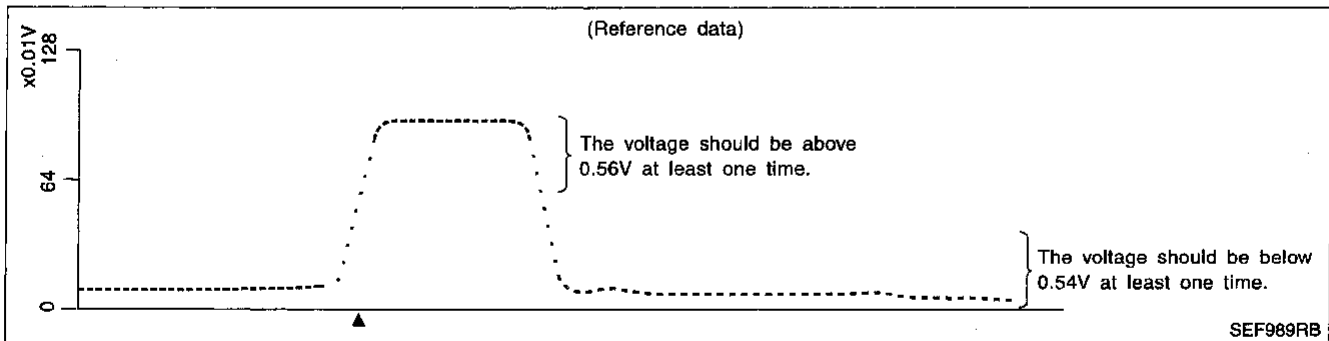

### CAUTION:

Discard any heated oxygen sensor which has been dropped from a height of more than 0.5 m (19.7 in) onto a hard surface such as a concrete floor; use a new one.

# DTC P0139 (RIGHT BANK, -B1), P0159 (LEFT BANK, -B2) REAR HEATED OXYGEN SENSOR (REAR HO2S) (RESPONSE MONITORING)

Component Description

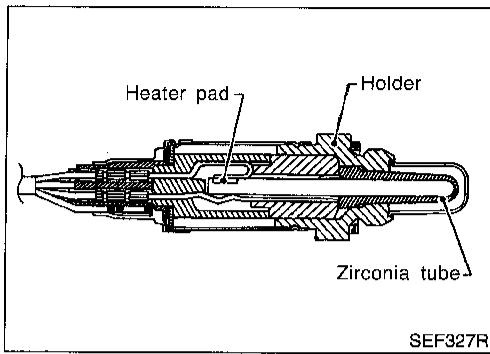

## Component Description

The rear heated oxygen sensor, after three way catalyst, monitors the oxygen level in the exhaust gas on each bank.

Even if switching characteristics of the front heated oxygen sensor are shifted, the air fuel ratio is controlled to stoichiometric, by the signal from the rear heated oxygen sensor.

This sensor is made of ceramic zirconia. The zirconia generates voltage from approximately 1V in richer conditions to 0V in leaner conditions.

Under normal conditions the rear heated oxygen sensor is not used for engine control operation.

## CONSULT Reference Value in Data Monitor Mode

Specification data are reference values.

MONITOR ITEM	CONDITION	SPECIFICATION
RR O2 SEN-B1 RR O2 SEN-B2	<ul style="list-style-type: none"> <li>Engine: After warming up</li> </ul> Revving engine from idle up to 2,000 rpm	0 - 0.3V ↔ Approx. 0.6 - 1.0V
RR O2 MNTR-B1 RR O2 MNTR-B2		LEAN ↔ RICH

## ECM Terminals and Reference Value

Specification data are reference values and are measured between each terminal and 32 (ECM ground).

TERMI- NAL NO.	WIRE COLOR	ITEM	CONDITION	DATA (DC Voltage)
56 (Right bank)	OR	Rear heated oxygen sensor	[Engine is running] <ul style="list-style-type: none"> <li>Revving engine from idle up to 2,000 rpm</li> </ul>	0 - Approximately 1.0V
57 (Left bank)	Y			

## On Board Diagnosis Logic

The rear heated oxygen sensor has a much longer switching time between rich and lean than the front heated oxygen sensor. The oxygen storage capacity before the three way catalyst causes the longer switching time. To judge the malfunctions of rear heated oxygen sensor, ECM monitors whether the switching response of the sensor's voltage is faster than specified during the various driving condition such as fuel-cut.

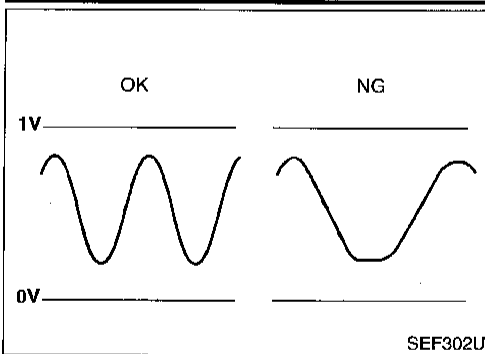

DTC No.	Malfunction is detected when ...	Check Items (Possible Cause)
P0139 0707 (Right bank)	<ul style="list-style-type: none"> <li>It takes more time for the sensor to respond between rich and lean than the specified time.</li> </ul>	<ul style="list-style-type: none"> <li>Harness or connectors (The sensor circuit is open or shorted.)</li> <li>Rear heated oxygen sensor</li> <li>Fuel pressure</li> <li>Injectors</li> <li>Intake air leaks</li> </ul>
P0159 0708 (Left bank)		

# DTC P0139 (RIGHT BANK, -B1), P0159 (LEFT BANK, -B2) REAR HEATED OXYGEN SENSOR (REAR HO2S) (RESPONSE MONITORING)

## DTC Confirmation Procedure

**6**

<p>■ RR O2 SEN-B1 P0139 ■ □</p> <p>COND1: OUT OF COND COND2: INCOMPLETE COND3: INCOMPLETE</p> <p>===== MONITOR =====</p> <p>CMPS-RPM(POS) 925rpm THRRTL POS SEN 0.46V B/FUEL SCHDL 1.5msec</p>	<p>■ RR O2 SEN-B2 P0159 ■ □</p> <p>COND1: OUT OF COND COND2: INCOMPLETE COND3: INCOMPLETE</p> <p>===== MONITOR =====</p> <p>CMPS-RPM(POS) 925rpm THRRTL POS SEN 0.46V B/FUEL SCHDL 1.5msec</p>
--	--

SEF712W

**8**

<p>■ RR O2 SEN-B1 P0139 ■ □</p> <p>COND1: TESTING COND2: INCOMPLETE COND3: INCOMPLETE</p> <p>===== MONITOR =====</p> <p>CMPS-RPM(POS) 1975rpm THRRTL POS SEN 1.10V B/FUEL SCHDL 4.4msec</p>	<p>■ RR O2 SEN-B2 P0159 ■ □</p> <p>COND1: TESTING COND2: INCOMPLETE COND3: INCOMPLETE</p> <p>===== MONITOR =====</p> <p>CMPS-RPM(POS) 1975rpm THRRTL POS SEN 1.10V B/FUEL SCHDL 4.4msec</p>
---	---

SEF713W

**8**

<p>■ RR O2 SEN-B1 P0139 ■ □</p> <p>COND1: COMPLETED COND2: INCOMPLETE COND3: INCOMPLETE</p> <p>===== MONITOR =====</p> <p>CMPS-RPM(POS) 1975rpm THRRTL POS SEN 1.10V B/FUEL SCHDL 4.4msec</p>	<p>■ RR O2 SEN-B2 P0159 ■ □</p> <p>COND1: COMPLETED COND2: INCOMPLETE COND3: INCOMPLETE</p> <p>===== MONITOR =====</p> <p>CMPS-RPM(POS) 1975rpm THRRTL POS SEN 1.10V B/FUEL SCHDL 4.4msec</p>
---	---

SEF714W

**1**

<p>■ RR O2 SEN-B1 P0139 ■ □</p> <p>COND1: COMPLETED COND2: COMPLETED COND3: INCOMPLETE</p> <p>===== MONITOR =====</p> <p>CMPS-RPM(POS) 1050rpm THRRTL POS SEN 0.51V B/FUEL SCHDL 1.0msec</p>	<p>■ RR O2 SEN-B2 P0159 ■ □</p> <p>COND1: COMPLETED COND2: COMPLETED COND3: INCOMPLETE</p> <p>===== MONITOR =====</p> <p>CMPS-RPM(POS) 1050rpm THRRTL POS SEN 0.51V B/FUEL SCHDL 1.0msec</p>
--	--

SEF715W

## DTC Confirmation Procedure

NEEC0450

### CAUTION:

Always drive vehicle at a safe speed.

### NOTE:

- "COMPLETED" will appear on CONSULT screen when all tests "COND1", "COND2" and "COND3" are completed.
- If "DTC Confirmation Procedure" has been previously conducted, always turn ignition switch "OFF" and wait at least 5 seconds before conducting the next test.

### TESTING CONDITION:

Never stop engine during this test. If the engine is stopped, reperform this test from step 2.

### ⑧ With CONSULT

#### Procedure for COND1

- 1) Start engine and warm it up to normal operating temperature.
- 2) Turn ignition switch "OFF" and wait at least 5 seconds.
- 3) Turn ignition switch "ON" and select "RR O2 SEN-B1 (-B2) P0139 (P0159)" of "REAR O2 SENSOR" in "DTC WORK SUPPORT" mode with CONSULT.
- 4) Touch "START".
- 5) Start engine and let it idle for at least 30 seconds.
- 6) Rev engine up to 2,000 rpm 2 or 3 times quickly under no load. If "COMPLETED" appears on CONSULT screen, go to step 2 in "Procedure for COND3". If "COMPLETED" does not appear on CONSULT screen, go to the following step.
- 7) Drive vehicle at a speed of more than 70 km/h (43 MPH) for 2 consecutive minutes.
- 8) When the following conditions are met, "TESTING" will be displayed at "COND1" on the CONSULT screen. Maintain the conditions continuously until "TESTING" changes to "COMPLETED". (It will take approximately 60 seconds.)

CMPS-RPM (POS)	1,300 - 3,100 rpm
Vehicle speed	64 - 130 km/h (40 - 80 MPH)
B/FUEL SCHDL	0.5 - 6.4 msec
Selector lever	Suitable position

### NOTE:

- If "TESTING" is not displayed after 5 minutes, retry from step 2 in "Procedure for COND1".
- If "COMPLETED" already appears at "COND2" on CONSULT screen before "Procedure for COND2" is conducted, it is unnecessary to conduct "Procedure for COND2".

#### Procedure for COND2

- 1) While driving, release accelerator pedal completely with "OD" OFF from the above condition (step 8) until "INCOMPLETE" at "COND2" on CONSULT screen is turned to "COMPLETED". (It will take approximately 4 seconds.)

### NOTE:

If "COMPLETED" is already appears at "COND3" on CONSULT screen before "Procedure for COND3" is conducted, it is unnecessary to conduct step 1 in "Procedure for COND3".



# DTC P0139 (RIGHT BANK, -B1), P0159 (LEFT BANK, -B2) REAR HEATED OXYGEN SENSOR (REAR HO2S) (RESPONSE MONITORING)

DTC Confirmation Procedure (Cont'd)

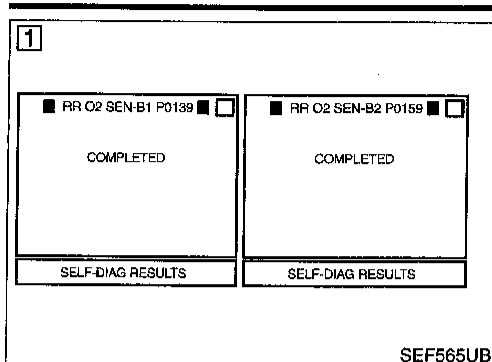

## Procedure for COND3

- 1) Stop vehicle and let it idle until "INCOMPLETE" of "COND3" on CONSULT screen has turned to "COMPLETED". (It will take maximum of approximately 6 minutes.)
- 2) Make sure that "OK" is displayed after touching "SELF-DIAG RESULTS".  
If "NG" is displayed, refer to "Diagnostic Procedure", EC-230.

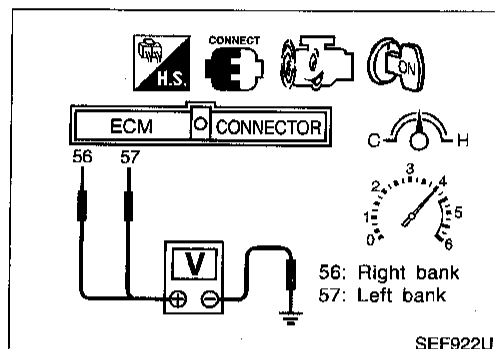

## Overall Function Check

Use this procedure to check the overall function of the rear heated oxygen sensor circuit. During this check, a 1st trip DTC might not be confirmed.

### ⊗ Without CONSULT

- 1) Start engine and drive vehicle at a speed of more than 70 km/h (43 MPH) for 2 consecutive minutes.
- 2) Stop vehicle with engine running.
- 3) Set voltmeter probes between ECM terminal 56 (right bank sensor signal) or 57 (left bank sensor signal) and engine ground.
- 4) Check the voltage when racing up to 4,000 rpm under no load at least 10 times.  
(depress and release accelerator pedal as soon as possible)  
**The voltage should change at more than 0.06V for 1 second during this procedure.**  
**If the voltage can be confirmed in step 4, step 5 is not necessary.**
- 5) Keep vehicle at idling for 10 minutes, then check the voltage.  
Or check the voltage when coasting from 80 km/h (50 MPH) in 3rd gear position (M/T), "D" position with "OD" OFF (A/T)..  
**The voltage should change at more than 0.06V for 1 second during this procedure.**
- 6) IF NG, go to "Diagnostic Procedure", EC-230.

GI  
MA  
EM  
LC  
EC  
FE  
CL  
MT  
AT  
TF  
PD  
FA  
RA  
BR  
ST  
RS  
BT  
HA  
EL  
IDX

# DTC P0139 (RIGHT BANK, -B1), P0159 (LEFT BANK, -B2) REAR HEATED OXYGEN SENSOR (REAR HO2S) (RESPONSE MONITORING)

Wiring Diagram

## Wiring Diagram

NEEC0452

NEEC0452S01

### RIGHT BANK

EC-RRO2RH-01

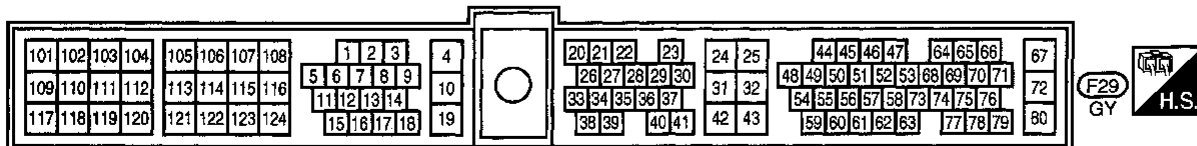
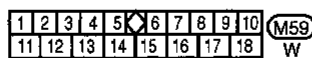
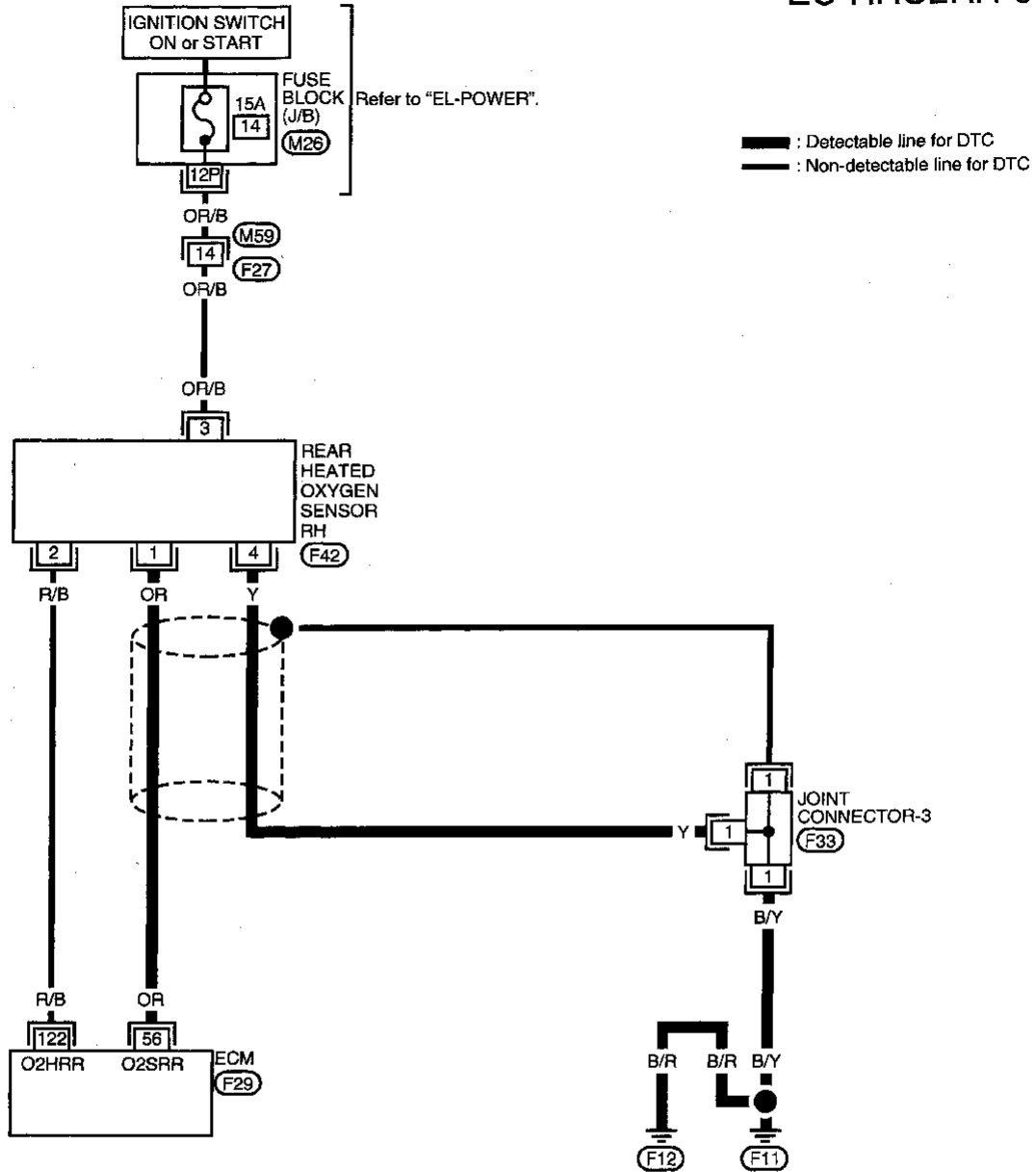

AEC733A

# DTC P0139 (RIGHT BANK, -B1), P0159 (LEFT BANK, -B2) REAR HEATED OXYGEN SENSOR (REAR HO2S) (RESPONSE MONITORING)

Wiring Diagram (Cont'd)

## LEFT BANK

NEEC0452S02

## EC-RR02LH-01

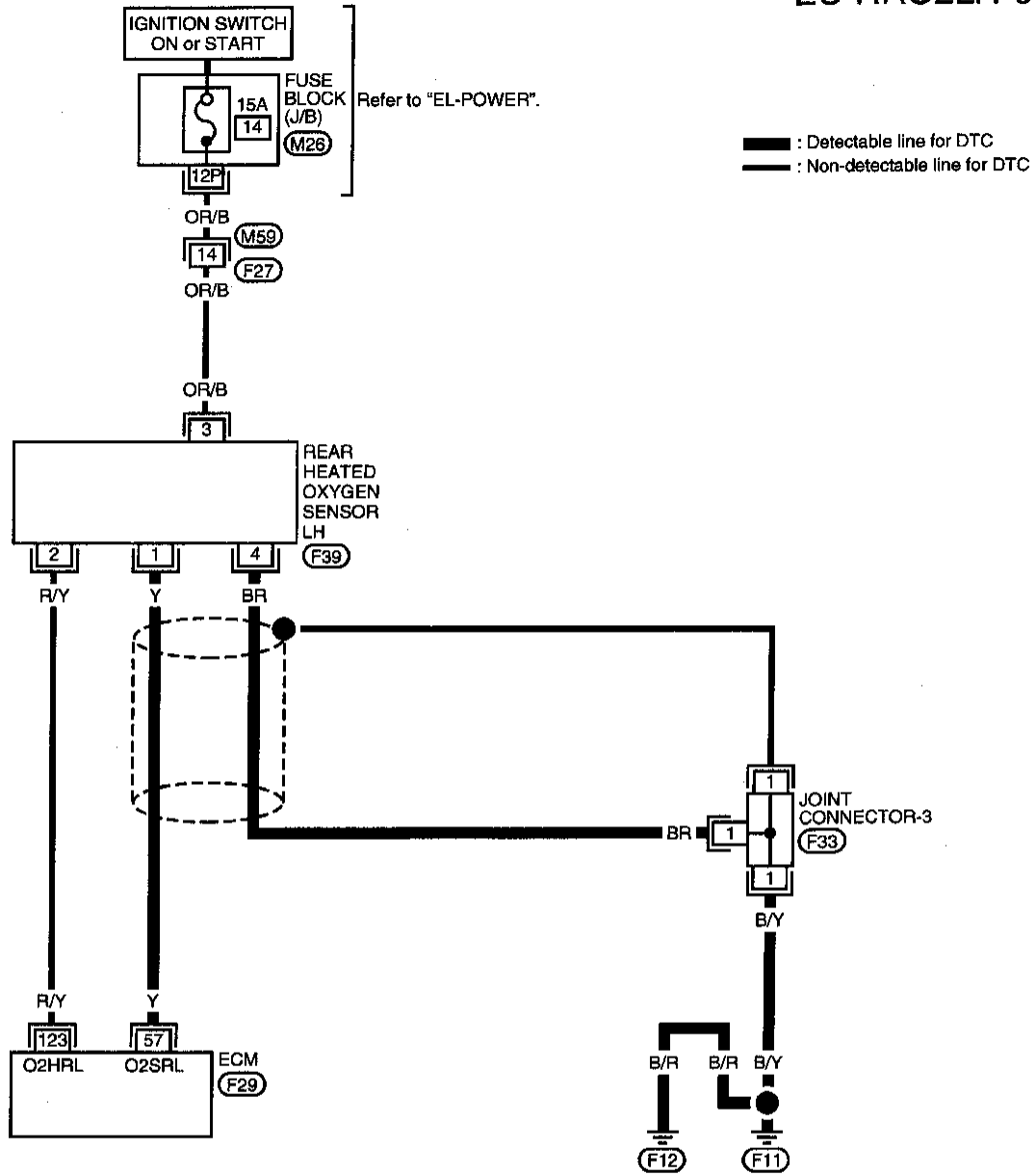

— : Detectable line for DTC  
 - - - : Non-detectable line for DTC

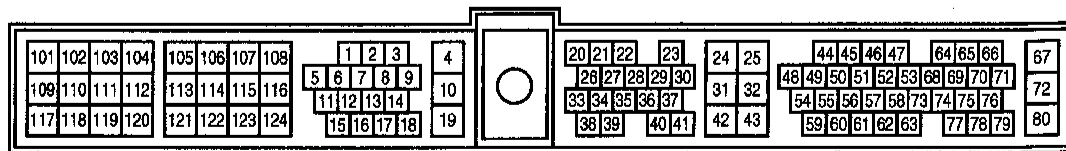
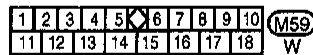

AEC734A

# DTC P0139 (RIGHT BANK, -B1), P0159 (LEFT BANK, -B2) REAR HEATED OXYGEN SENSOR (REAR HO2S) (RESPONSE MONITORING)

Diagnostic Procedure

## Diagnostic Procedure

NEEC0453

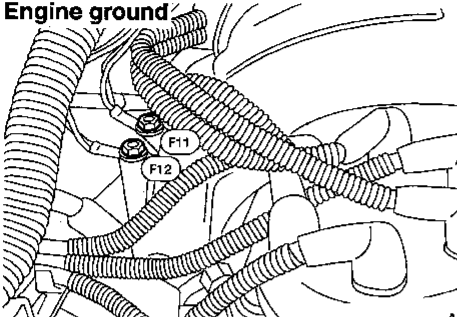
<b>1</b>	<b>RETIGHTEN GROUND SCREWS</b>
<ol style="list-style-type: none"> <li>1. Turn ignition switch "OFF".</li> <li>2. Loosen and retighten engine ground screws.</li> </ol>	
<p><b>Engine ground</b></p>  <p style="text-align: right;">AEC640A</p>	
▶	GO TO 2.

<b>2</b>	<b>CLEAR THE SELF-LEARNING DATA</b>																						
<p><input checked="" type="checkbox"/> <b>With CONSULT</b></p> <ol style="list-style-type: none"> <li>1. Start engine and warm it up to normal operating temperature.</li> <li>2. Select "SELF-LEARNING CONT" in "ACTIVE TEST" mode with CONSULT.</li> <li>3. Clear the self-learning control coefficient by touching "CLEAR".</li> </ol>																							
<table border="1" style="margin: auto;"> <tr> <td colspan="2" style="text-align: center;">■ ACTIVE TEST ■</td> </tr> <tr> <td>SELF-LEARN</td> <td>B1 : 100%</td> </tr> <tr> <td>CONTROL</td> <td>B2 : 100%</td> </tr> <tr> <td colspan="2" style="text-align: center;">===== MONITOR =====</td> </tr> <tr> <td>CMPS-RPM(REF)</td> <td>750rpm</td> </tr> <tr> <td>COOLAN TEMP/S</td> <td>93°C</td> </tr> <tr> <td>FR O2 SEN-B1</td> <td>0.90V</td> </tr> <tr> <td>FR O2 SEN-B2</td> <td>0.90V</td> </tr> <tr> <td>A/F ALPHA-B1</td> <td>100%</td> </tr> <tr> <td>A/F ALPHA-B2</td> <td>100%</td> </tr> <tr> <td colspan="2" style="text-align: center;"><b>CLEAR</b></td> </tr> </table>		■ ACTIVE TEST ■		SELF-LEARN	B1 : 100%	CONTROL	B2 : 100%	===== MONITOR =====		CMPS-RPM(REF)	750rpm	COOLAN TEMP/S	93°C	FR O2 SEN-B1	0.90V	FR O2 SEN-B2	0.90V	A/F ALPHA-B1	100%	A/F ALPHA-B2	100%	<b>CLEAR</b>	
■ ACTIVE TEST ■																							
SELF-LEARN	B1 : 100%																						
CONTROL	B2 : 100%																						
===== MONITOR =====																							
CMPS-RPM(REF)	750rpm																						
COOLAN TEMP/S	93°C																						
FR O2 SEN-B1	0.90V																						
FR O2 SEN-B2	0.90V																						
A/F ALPHA-B1	100%																						
A/F ALPHA-B2	100%																						
<b>CLEAR</b>																							
SEF921U																							
<ol style="list-style-type: none"> <li>4. Run engine for at least 10 minutes at idle speed.  <b>Is the 1st trip DTC P0171, P0172, P0174 or P0175 detected?</b>  <b>Is it difficult to start engine?</b> </li> </ol>																							
<p><input checked="" type="checkbox"/> <b>Without CONSULT</b></p> <ol style="list-style-type: none"> <li>1. Start engine and warm it up to normal operating temperature.</li> <li>2. Turn ignition switch "OFF".</li> <li>3. Disconnect mass air flow sensor harness connector, and restart and run engine for at least 5 seconds at idle speed.</li> <li>4. Stop engine and reconnect mass air flow sensor harness connector.</li> <li>5. Make sure 1st trip DTC No. 0102 is displayed in Diagnostic Test Mode II.</li> <li>6. Erase the diagnostic test mode II (Self-diagnostic results) memory. Refer to "HOW TO ERASE EMISSION-RELATED DIAGNOSTIC INFORMATION", EC-55.</li> <li>7. Make sure DTC No. 0505 is displayed in Diagnostic Test Mode II.</li> <li>8. Run engine for at least 10 minutes at idle speed.  <b>Is the 1st trip DTC 0114, 0115, 0209 or 0210 detected?</b>  <b>Is it difficult to start engine?</b> </li> </ol>																							
<b>Yes or No</b>																							
Yes	▶ Perform trouble diagnosis for DTC P0171, P0174 or P0172, P0175. Refer to EC-247, 254.																						
No	▶ GO TO 3.																						

# DTC P0139 (RIGHT BANK, -B1), P0159 (LEFT BANK, -B2) REAR HEATED OXYGEN SENSOR (REAR HO2S) (RESPONSE MONITORING)

Diagnostic Procedure (Cont'd)

## 3 CHECK INPUT SIGNAL CIRCUIT

1. Turn ignition switch "OFF".
2. Disconnect corresponding rear heated oxygen sensor harness connector.

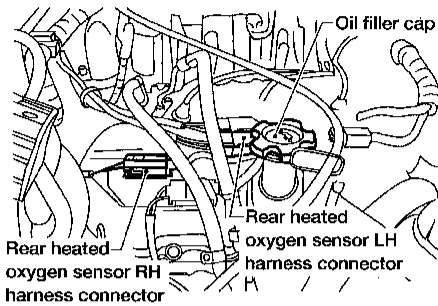

AEC645A

3. Disconnect ECM harness connector.
4. Check harness continuity between ECM terminal and sensor terminal as follows.

DTC	Terminals		Bank
	ECM	Sensor	
P0139	56	1	Right
P0159	57	1	Left

AEC899A

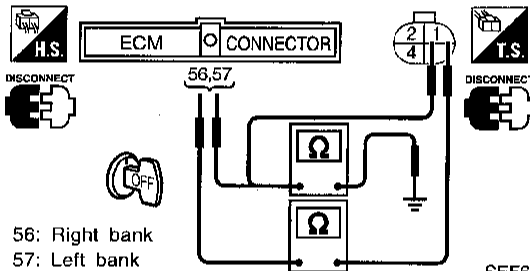

56: Right bank  
57: Left bank

SEF635W

**Continuity should exist.**

5. Check harness continuity between ECM terminal or sensor terminal and ground as follows.

DTC	Terminals		Bank
	ECM or sensor	Ground	
P0139	56 or 1	Ground	Right
P0159	57 or 1	Ground	Left

AEC900A

**Continuity should not exist.**

6. Also check harness for short to power.

**OK or NG**

OK	▶	GO TO 4.
NG	▶	Repair open circuit or short to ground or short to power in harness or connectors.

## 4 CHECK GROUND CIRCUIT

1. Check harness continuity between terminal 4 and engine ground.

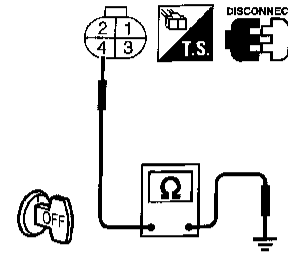

SEF636W

**Continuity should exist.**

2. Also check harness for short to ground and short to power.

**OK or NG**

OK	▶	GO TO 6.
NG	▶	GO TO 5.

## 5 DETECT MALFUNCTIONING PART

Check the following.

- Joint connector-3
- Harness for open or short between rear heated oxygen sensor and engine ground.

▶ Repair open circuit or short to ground or short to power in harness or connectors.

## 6 CHECK REAR HEATED OXYGEN SENSOR

Refer to "Component Inspection", EC-232.

**OK or NG**

OK	▶	GO TO 7.
NG	▶	Replace malfunctioning rear heated oxygen sensor.

## 7 CHECK SHIELD CIRCUIT

1. Turn ignition switch "OFF".
2. Disconnect joint connector.
3. Check the following.
  - Continuity between joint connector terminal and ground
  - Joint connector  
(Refer to "HARNES LAYOUT" in EL section.)

**Continuity should exist.**
4. Also check harness for short to ground and short to power.
5. Then reconnect joint connector.

**OK or NG**

OK	▶	GO TO 8.
NG	▶	Repair open circuit or short to ground or short to power in harness or connectors.

GI  
MA  
EM  
LC  
EC  
FE  
CL  
MT  
AT  
TF  
PD  
FA  
RA  
BR  
ST  
RS  
BT  
HA  
EL  
IDX

# DTC P0139 (RIGHT BANK, -B1), P0159 (LEFT BANK, -B2) REAR HEATED OXYGEN SENSOR (REAR HO2S) (RESPONSE MONITORING)

Diagnostic Procedure (Cont'd)

<b>8</b>	<b>CHECK INTERMITTENT INCIDENT</b>
Refer to "TROUBLE DIAGNOSIS FOR INTERMITTENT INCIDENT", EC-115.	
▶	<b>INSPECTION END</b>

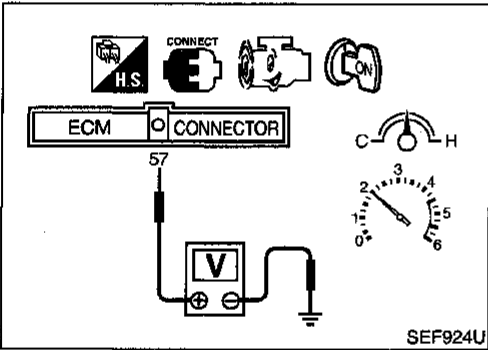
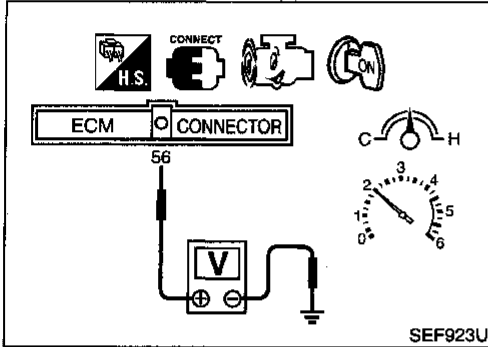

## Component Inspection REAR HEATED OXYGEN SENSOR

NEEC0454

NEEC0454S01

### Ⓜ With CONSULT

- 1) Start engine and drive vehicle at a speed of more than 70 km/h (43 MPH) for 2 consecutive minutes.
- 2) Stop vehicle with engine running.
- 3) Select "FUEL INJECTION" in "ACTIVE TEST" mode, and select "RR O2 SEN-B1 (-B2)" as the monitor item with CONSULT.
- 4) Check "RR O2 SEN-B1 (-B2)" at idle speed when adjusting "FUEL INJECTION" to  $\pm 25\%$ .

"RR O2 SEN-B1 (-B2)" should be above 0.56V at least once when the "FUEL INJECTION" is +25%.

"RR O2 SEN-B1 (-B2)" should be below 0.54V at least once when the "FUEL INJECTION" is -25%.

### Ⓧ Without CONSULT

- 1) Start engine and drive vehicle at a speed of more than 70 km/h (43 MPH) for 2 consecutive minutes.
- 2) Stop vehicle with engine running.
- 3) Set voltmeter probes between ECM terminal 56 (right bank sensor signal) or 57 (left bank sensor signal) and ECM terminal 32 (engine ground).
- 4) Check the voltage when racing up to 4,000 rpm under no load at least 10 times.  
(depress and release accelerator pedal as soon as possible)  
**The voltage should be above 0.56V at least once during this procedure.**  
**If the voltage is above 0.56V at step 4, step 5 is not necessary.**
- 5) Keep vehicle at idling for 10 minutes, then check the voltage. Or check the voltage when coasting from 80 km/h (50 MPH) in 3rd gear position (M/T), "D" position with "OD" OFF (A/T).  
**The voltage should be below 0.54V at least once during this procedure.**

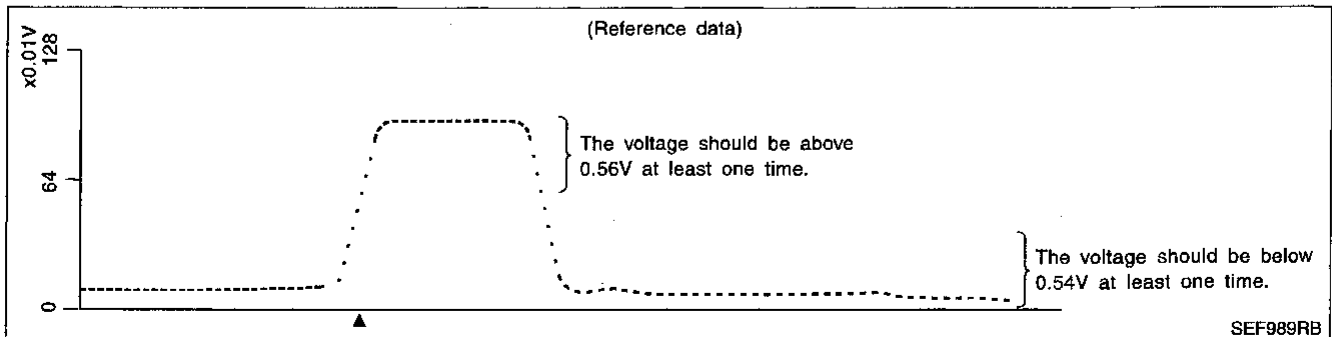

**DTC P0139 (RIGHT BANK, -B1), P0159 (LEFT BANK, -B2) REAR HEATED  
OXYGEN SENSOR (REAR HO2S) (RESPONSE MONITORING)**

*Component Inspection (Cont'd)*

**CAUTION:**

Discard any heated oxygen sensor which has been dropped from a height of more than 0.5 m (19.7 in) onto a hard surface such as a concrete floor; use a new one.

GI

MA

EM

LC

**EC**

FE

CL

MT

AT

TF

PD

FA

RA

BR

ST

RS

BT

HA

EL

IDX

# DTC P0140 (RIGHT BANK, -B1), P0160 (LEFT BANK, -B2) REAR HEATED OXYGEN SENSOR (REAR HO2S) (HIGH VOLTAGE)

## Component Description

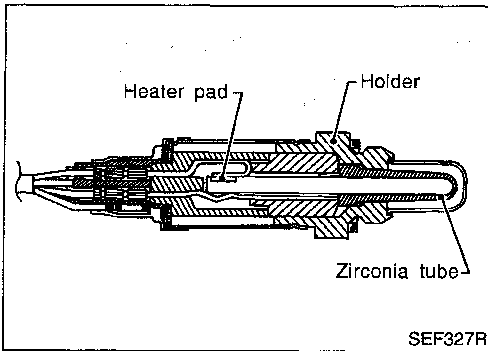

## Component Description

NEEC0455

The rear heated oxygen sensor, after three way catalyst, monitors the oxygen level in the exhaust gas on each bank.

Even if switching characteristics of the front heated oxygen sensor are shifted, the air fuel ratio is controlled to stoichiometric, by the signal from the rear heated oxygen sensor.

This sensor is made of ceramic zirconia. The zirconia generates voltage from approximately 1V in richer conditions to 0V in leaner conditions.

Under normal conditions the rear heated oxygen sensor is not used for engine control operation.

## CONSULT Reference Value in Data Monitor Mode

NEEC0456

Specification data are reference values.

MONITOR ITEM	CONDITION	SPECIFICATION
RR O2 SEN-B1 RR O2 SEN-B2	<ul style="list-style-type: none"> <li>Engine: After warming up</li> </ul> Revving engine from idle up to 2,000 rpm	0 - 0.3V ↔ Approx. 0.6 - 1.0V
RR O2 MNTR-B1 RR O2 MNTR-B2		LEAN ↔ RICH

## ECM Terminals and Reference Value

NEEC0457

Specification data are reference values and are measured between each terminal and 32 (ECM ground).

TERMI- NAL NO.	WIRE COLOR	ITEM	CONDITION	DATA (DC Voltage)
56 (Right bank)	OR	Rear heated oxygen sen- sor	[Engine is running] <ul style="list-style-type: none"> <li>Warm-up condition</li> <li>Revving engine from idle up to 2,000 rpm</li> </ul>	0 - Approximately 1.0V
57 (Left bank)	Y			

## On Board Diagnosis Logic

NEEC0458

The rear heated oxygen sensor has a much longer switching time between rich and lean than the front heated oxygen sensor. The oxygen storage capacity before the three way catalyst causes the longer switching time. To judge the malfunctions of rear heated oxygen sensor, ECM monitors whether the voltage is unusually high during the various driving condition such as fuel-cut.

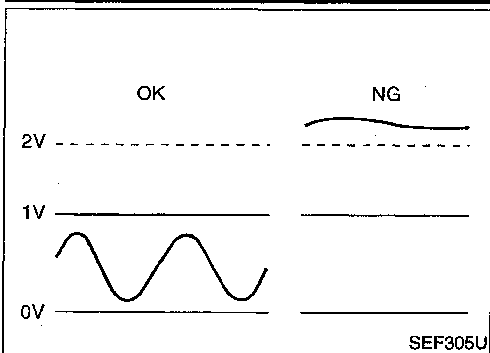

DTC No.	Malfunction is detected when ...	Check Items (Possible Cause)
P0140 0512 (Right bank)	<ul style="list-style-type: none"> <li>An excessively high voltage from the sensor is sent to ECM.</li> </ul>	<ul style="list-style-type: none"> <li>Harness or connectors (The sensor circuit is open or shorted.)</li> <li>Rear heated oxygen sensor</li> </ul>
P0160 0315 (Left bank)		



# DTC P0140 (RIGHT BANK, -B1), P0160 (LEFT BANK, -B2) REAR HEATED OXYGEN SENSOR (REAR HO2S) (HIGH VOLTAGE)

DTC Confirmation Procedure

5

☆ MONITOR
☆ NO FAIL

CMPS-RPM(REF)	812rpm
COOLAN TEMP/S	85°C
VHCL SPEED SE	0km/h
P/N POSI SW	ON
B/FUEL SCHDL	0.9msec

**RECORD**

AEC918A

## DTC Confirmation Procedure

NEEC0459

### CAUTION:

Always drive vehicle at a safe speed.

### NOTE:

If "DTC Confirmation Procedure" has been previously conducted, always turn ignition switch "OFF" and wait at least 5 seconds before conducting the next test.

### ④ With CONSULT

- 1) Turn ignition switch "ON" and select "DATA MONITOR" mode with CONSULT.
- 2) Start engine and drive vehicle at a speed of more than 70 km/h (43 MPH) for 2 consecutive minutes.
- 3) Stop vehicle with engine running.
- 4) Let engine idle for 1 minute.
- 5) Maintain the following conditions for at least 5 consecutive seconds.

CMPS-RPM (REF)	1,300 - 3,100 rpm
VHCL SPEED SE	64 - 130 km/h (40 - 80 MPH)
B/FUEL SCHDL	0.5 - 6.4 msec
COOLAN TEMP/S	70 - 100°C (158 - 212°F)
Selector lever	Suitable position

- 6) If 1st trip DTC is detected, go to "Diagnostic Procedure", EC-238.

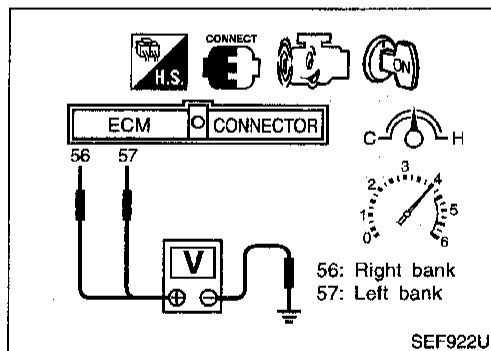

## Overall Function Check

NEEC0460

Use this procedure to check the overall function of the rear heated oxygen sensor circuit. During this check, a 1st trip DTC might not be confirmed.

### ⊗ Without CONSULT

- 1) Start engine and drive vehicle at a speed of more than 70 km/h (43 MPH) for 2 consecutive minutes.
- 2) Stop vehicle with engine running.
- 3) Set voltmeter probes between ECM terminal 56 (right bank sensor signal) or 57 (left bank sensor signal) and engine ground.
- 4) Check the voltage when racing up to 4,000 rpm under no load at least 10 times.  
(depress and release accelerator pedal as soon as possible)  
**The voltage should be below 2V during this procedure.**
- 5) If NG, go to "Diagnostic Procedure", EC-238.

# DTC P0140 (RIGHT BANK, -B1), P0160 (LEFT BANK, -B2) REAR HEATED OXYGEN SENSOR (REAR HO2S) (HIGH VOLTAGE)

Wiring Diagram

## Wiring Diagram

RIGHT BANK

NEEC0461

NEEC0461S01

EC-RR02RH-01

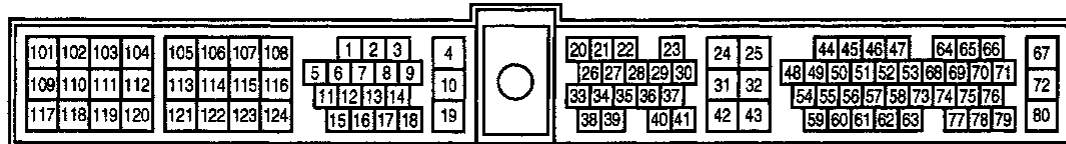
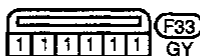
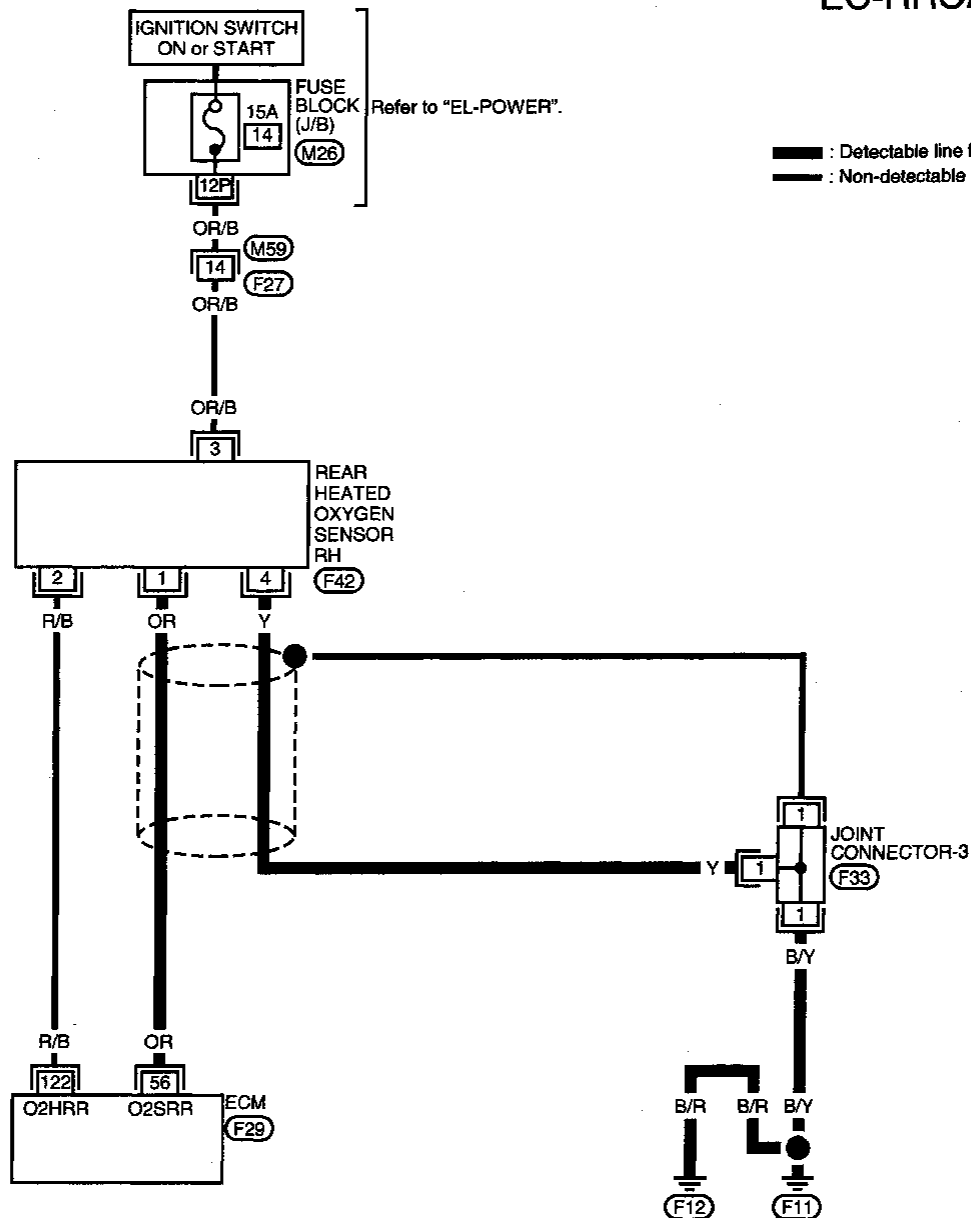

AEC733A

# DTC P0140 (RIGHT BANK, -B1), P0160 (LEFT BANK, -B2) REAR HEATED OXYGEN SENSOR (REAR HO2S) (HIGH VOLTAGE)

Wiring Diagram (Cont'd)

## LEFT BANK

NEEC0461502

## EC-RRO2LH-01

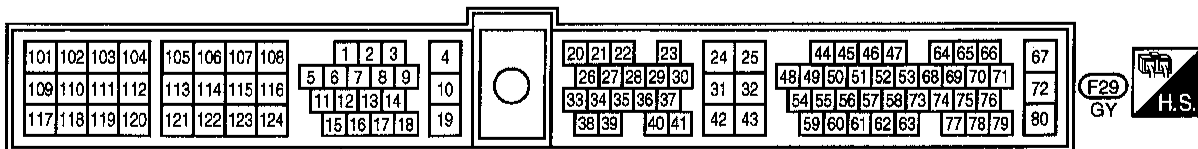
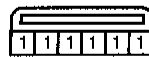
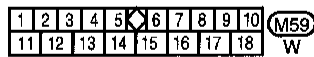
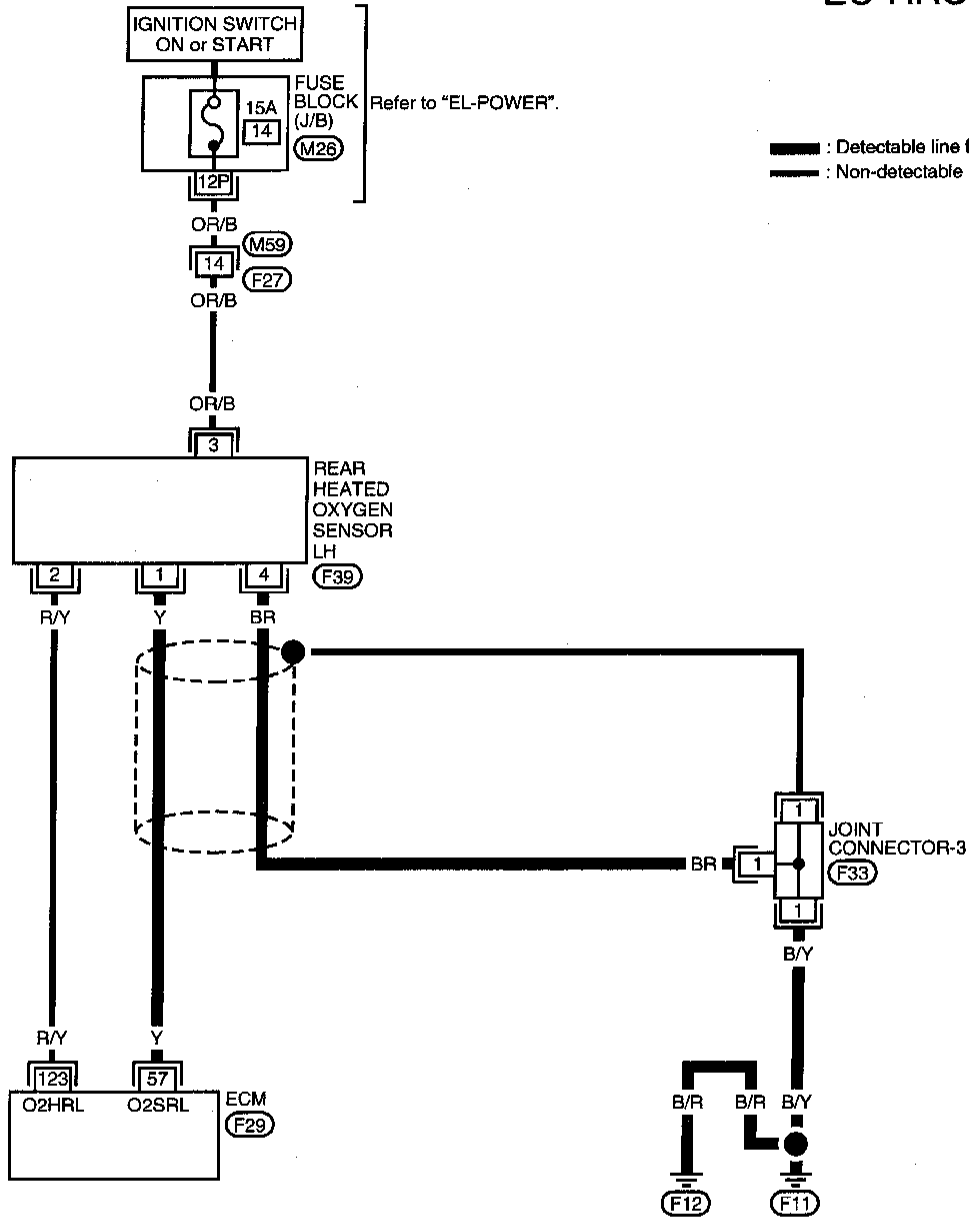

AEC734A

# DTC P0140 (RIGHT BANK, -B1), P0160 (LEFT BANK, -B2) REAR HEATED OXYGEN SENSOR (REAR HO2S) (HIGH VOLTAGE)

Diagnostic Procedure

## Diagnostic Procedure

NEEC0482

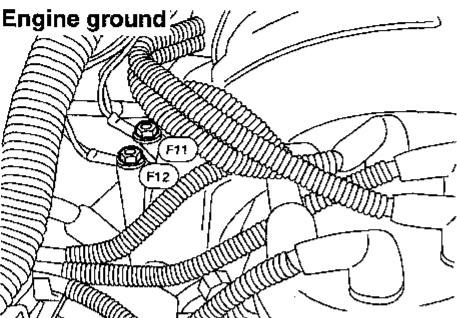
<b>1</b>	<b>INSPECTION START</b>
<ol style="list-style-type: none"> <li>Turn ignition switch "OFF".</li> <li>Loosen and retighten engine ground screws.</li> </ol>	
 <p><b>Engine ground</b></p>	
AEC640A	
<ol style="list-style-type: none"> <li>Disconnect corresponding rear heated oxygen sensor harness connector.</li> <li>Disconnect ECM harness connector.</li> </ol>	
▶ GO TO 2.	

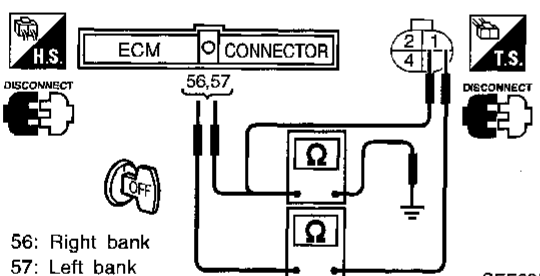
<b>2</b>	<b>CHECK INPUT SIGNAL CIRCUIT</b>														
<ol style="list-style-type: none"> <li>Check harness continuity between ECM terminal and sensor terminal as follows.</li> </ol>															
<table border="1"> <thead> <tr> <th rowspan="2">DTC</th> <th colspan="2">Terminals</th> <th rowspan="2">Bank</th> </tr> <tr> <th>ECM</th> <th>Sensor</th> </tr> </thead> <tbody> <tr> <td>P0140</td> <td>56</td> <td>1</td> <td>Right</td> </tr> <tr> <td>P0160</td> <td>57</td> <td>1</td> <td>Left</td> </tr> </tbody> </table>	DTC	Terminals		Bank	ECM	Sensor	P0140	56	1	Right	P0160	57	1	Left	AEC901A
DTC		Terminals			Bank										
	ECM	Sensor													
P0140	56	1	Right												
P0160	57	1	Left												
															
<p>56: Right bank 57: Left bank</p> <p style="text-align: right;">SEF635W</p>															
<p><b>Continuity should exist.</b></p> <ol style="list-style-type: none"> <li>Check harness continuity between ECM terminal or sensor terminal and ground as follows.</li> </ol>															
<table border="1"> <thead> <tr> <th rowspan="2">DTC</th> <th colspan="2">Terminals</th> <th rowspan="2">Bank</th> </tr> <tr> <th>ECM or sensor</th> <th>Ground</th> </tr> </thead> <tbody> <tr> <td>P0140</td> <td>56 or 1</td> <td>Ground</td> <td>Right</td> </tr> <tr> <td>P0160</td> <td>57 or 1</td> <td>Ground</td> <td>Left</td> </tr> </tbody> </table>	DTC	Terminals		Bank	ECM or sensor	Ground	P0140	56 or 1	Ground	Right	P0160	57 or 1	Ground	Left	AEC902A
DTC		Terminals			Bank										
	ECM or sensor	Ground													
P0140	56 or 1	Ground	Right												
P0160	57 or 1	Ground	Left												
<p><b>Continuity should not exist.</b></p> <ol style="list-style-type: none"> <li>Also check harness for short to power.</li> </ol>															
<b>OK or NG</b>															
OK	▶	GO TO 3.													
NG	▶	Repair open circuit or short to ground or short to power in harness or connectors.													

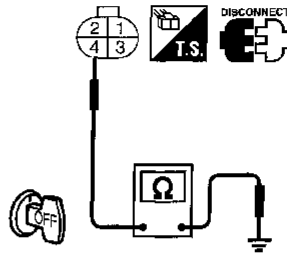
<b>3</b>	<b>CHECK GROUND CIRCUIT</b>	
<ol style="list-style-type: none"> <li>Check harness continuity between terminal 4 and engine ground.</li> </ol>		
		
<p style="text-align: center;"><b>Continuity should exist.</b></p> <ol style="list-style-type: none"> <li>Also check harness for short to ground and short to power.</li> </ol>		
<b>OK or NG</b>		
OK	▶	GO TO 5.
NG	▶	GO TO 4.

<b>4</b>	<b>DETECT MALFUNCTIONING PART</b>
<p>Check the following.</p> <ul style="list-style-type: none"> <li>Joint connector-3</li> <li>Harness for open or short between rear heated oxygen sensor and engine ground.</li> </ul>	
▶ Repair open circuit or short to ground or short to power in harness or connectors.	

<b>5</b>	<b>CHECK CONNECTORS FOR WATER</b>	
<p>Check rear heated oxygen sensor connector and harness connector for water.</p> <p><b>Water should not exist.</b></p>		
<b>OK or NG</b>		
OK	▶	GO TO 6.
NG	▶	Repair or replace harness or connectors.

<b>6</b>	<b>CHECK REAR HEATED OXYGEN SENSOR</b>	
<p>Refer to "Component Inspection", EC-239.</p>		
<b>OK or NG</b>		
OK	▶	GO TO 7.
NG	▶	Replace malfunctioning front heated oxygen sensor.

# DTC P0140 (RIGHT BANK, -B1), P0160 (LEFT BANK, -B2) REAR HEATED OXYGEN SENSOR (REAR HO2S) (HIGH VOLTAGE)

Diagnostic Procedure (Cont'd)

<b>7</b>	<b>CHECK SHIELD CIRCUIT</b>
<ol style="list-style-type: none"> <li>1. Turn ignition switch "OFF".</li> <li>2. Disconnect joint connector.</li> <li>3. Check the following. <ul style="list-style-type: none"> <li>• Continuity between joint connector terminal and ground</li> <li>• Joint connector (Refer to "HARNES LAYOUT" in EL section.)</li> </ul> <p style="text-align: center;"><b>Continuity should exist.</b></p> </li> <li>4. Also check harness for short to ground and short to power.</li> <li>5. Then reconnect joint connector.</li> </ol> <p style="text-align: center;"><b>OK or NG</b></p>	
OK	▶ GO TO 8.
NG	▶ Repair open circuit or short to ground or short to power in harness or connectors.

<b>8</b>	<b>CHECK INTERMITTENT INCIDENT</b>
Refer to "TROUBLE DIAGNOSIS FOR INTERMITTENT INCIDENT", EC-115.	
▶ <b>INSPECTION END</b>	

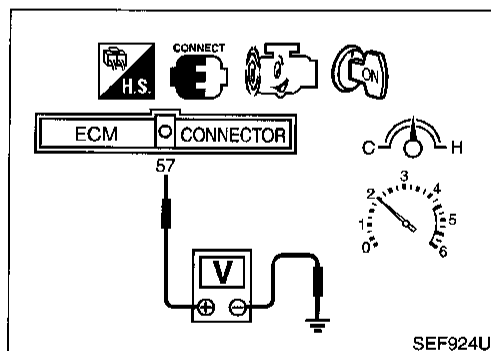
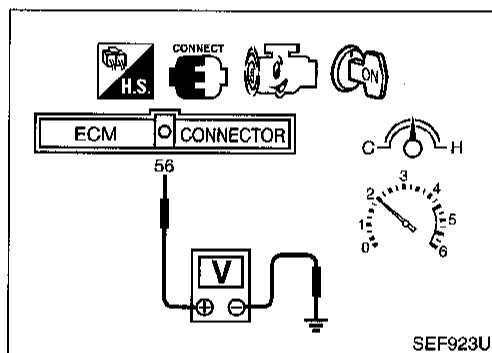

## Component Inspection REAR HEATED OXYGEN SENSOR

NEEC0463

NEEC0463S01

### Ⓜ With CONSULT

- 1) Start engine and drive vehicle at a speed of more than 70 km/h (43 MPH) for 2 consecutive minutes.
- 2) Stop vehicle with engine running.
- 3) Select "FUEL INJECTION" in "ACTIVE TEST" mode, and select "RR O2 SEN-B1 (-B2)" as the monitor item with CONSULT.
- 4) Check "RR O2 SEN-B1 (-B2)" at idle speed when adjusting "FUEL INJECTION" to  $\pm 25\%$ .

**"RR O2 SEN-B1 (-B2)" should be above 0.56V at least once when the "FUEL INJECTION" is +25%.**

**"RR O2 SEN-B1 (-B2)" should be below 0.54V at least once when the "FUEL INJECTION" is -25%.**

### Ⓧ Without CONSULT

- 1) Start engine and drive vehicle at a speed of more than 70 km/h (43 MPH) for 2 consecutive minutes.
- 2) Stop vehicle with engine running.
- 3) Set voltmeter probes between ECM terminal 56 (right bank sensor signal) or 57 (left bank sensor signal) and engine ground.
- 4) Check the voltage when racing up to 4,000 rpm under no load at least 10 times.  
(depress and release accelerator pedal as soon as possible)  
**The voltage should be above 0.56V at least once during this procedure.**  
**If the voltage is above 0.56V at step 4, step 5 is not necessary.**
- 5) Keep vehicle at idling for 10 minutes, then check the voltage. Or check the voltage when coasting from 80 km/h (50 MPH) in 3rd gear position (M/T), "D" position with "OD" OFF (A/T).  
**The voltage should be below 0.54V at least once during this procedure.**

EC-239

# DTC P0140 (RIGHT BANK, -B1), P0160 (LEFT BANK, -B2) REAR HEATED OXYGEN SENSOR (REAR HO2S) (HIGH VOLTAGE)

Component Inspection (Cont'd)

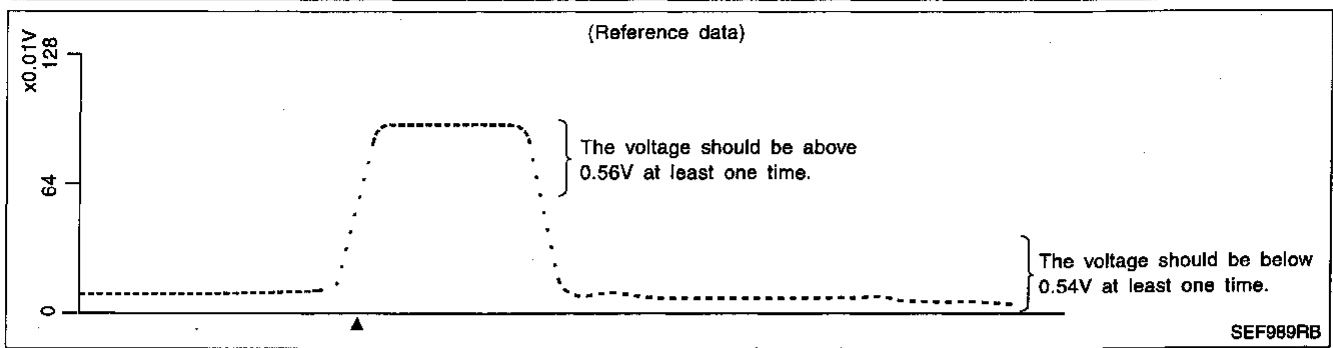

### CAUTION:

Discard any heated oxygen sensor which has been dropped from a height of more than 0.5 m (19.7 in) onto a hard surface such as a concrete floor; use a new one.

# DTC P0141 (RIGHT BANK, -B1), P0161 (LEFT BANK, -B2) REAR HEATED OXYGEN SENSOR HEATER

*Description*

Description			
<b>SYSTEM DESCRIPTION</b>			
Sensor	Input Signal to ECM	ECM function	Actuator
Camshaft position sensor	Engine speed	Rear heated oxygen sensor heater control	Rear heated oxygen sensor heaters

The ECM performs ON/OFF control of the rear heated oxygen sensor heaters corresponding to the engine speed.

## OPERATION

Engine speed rpm	Rear heated oxygen sensor heaters
Above 3,200	OFF
Below 3,200	ON

## CONSULT Reference Value in Data Monitor Mode

Specification data are reference values.

MONITOR ITEM	CONDITION	SPECIFICATION
RR O2 HTR-B1 RR O2 HTR-B2	<ul style="list-style-type: none"> <li>• Ignition switch: ON (Engine stopped)</li> <li>• Engine is running above 3,200 rpm.</li> </ul>	OFF
	<ul style="list-style-type: none"> <li>• Engine is running below 3,200 rpm after driving for 2 minutes at a speed of 70 km/h (43 MPH) or more.</li> </ul>	ON

## ECM Terminals and Reference Value

Specification data are reference values and are measured between each terminal and 32 (ECM ground).

TERMINAL NO.	WIRE COLOR	ITEM	CONDITION	DATA (DC Voltage)
122 (Right bank)	R/B	Rear heated oxygen sensor heater	<b>[Ignition switch "ON"]</b> <ul style="list-style-type: none"> <li>• Engine stopped</li> </ul> <b>[Engine is running]</b> <ul style="list-style-type: none"> <li>• Engine speed is above 3,200 rpm</li> </ul>	BATTERY VOLTAGE (11 - 14V)
123 (Left bank)	R/Y		<b>[Engine is running]</b> <ul style="list-style-type: none"> <li>• Engine speed is below 3,200 rpm</li> <li>• After driving for 2 minutes at a speed of 70 km/h (43 MPH) or more</li> </ul>	Approximately 0.4V

## On Board Diagnosis Logic

DTC No.	Malfunction is detected when ...	Check Items (Possible Cause)
P0141 0902 (Right bank)	<ul style="list-style-type: none"> <li>• The current amperage in the rear heated oxygen sensor heater circuit is out of the normal range. (An improper voltage drop signal is sent to ECM through the rear heated oxygen sensor heater.)</li> </ul>	<ul style="list-style-type: none"> <li>• Harness or connectors (The rear heated oxygen sensor heater circuit is open or shorted.)</li> <li>• Rear heated oxygen sensor heater</li> </ul>
P0161 1002 (Left bank)		

# DTC P0141 (RIGHT BANK, -B1), P0161 (LEFT BANK, -B2) REAR HEATED OXYGEN SENSOR HEATER

## DTC Confirmation Procedure

4

☆ MONITOR	☆ NO FAIL	<input type="checkbox"/>
CMPS•RPM(REF)	750 rpm	
<b>RECORD</b>		

SEF357VC

## DTC Confirmation Procedure

NEEC0116

### NOTE:

If "DTC Confirmation Procedure" has been previously conducted, always turn ignition switch "OFF" and wait at least 5 seconds before conducting the next test.

### TESTING CONDITION:

Before performing the following procedure, confirm that battery voltage is between 10.5V and 16V at idle.

#### CONSULT With CONSULT

- 1) Turn ignition switch "ON" and select "DATA MONITOR" mode with CONSULT.
- 2) Start engine.
- 3) Drive vehicle at a speed of more than 70 km/h (43 MPH) for 2 consecutive minutes.
- 4) Stop vehicle and let engine idle for at least 6 seconds.
- 5) If 1st trip DTC is detected, go to "Diagnostic Procedure", EC-245.

#### GST With GST

- 1) Start engine.
- 2) Drive vehicle at a speed of more than 70 km/h (43 MPH) for 2 consecutive minutes.
- 3) Stop vehicle and let engine idle for at least 6 seconds.
- 4) Turn ignition switch "OFF" and wait at least 5 seconds.
- 5) Start engine.
- 6) Drive vehicle at a speed of more than 70 km/h (43 MPH) for 2 consecutive minutes.
- 7) Stop vehicle and let engine idle for at least 6 seconds.
- 8) Select "MODE 3" with GST.
- 9) If DTC is detected, go to "Diagnostic Procedure", EC-245.

#### ECM No Tools

- 1) Start engine.
  - 2) Drive vehicle at a speed of more than 70 km/h (43 MPH) for 2 consecutive minutes.
  - 3) Stop vehicle and let engine idle for at least 6 seconds.
  - 4) Turn ignition switch "OFF", wait at least 5 seconds and then turn "ON".
  - 5) Perform "Diagnostic Test Mode II (Self-diagnostic results)" with ECM.
  - 6) If 1st trip DTC is detected, go to "Diagnostic Procedure", EC-245.
- When using GST, "DTC Confirmation Procedure" should be performed twice as much as when using CONSULT or ECM (Diagnostic Test Mode II) because GST cannot display MODE 7 (1st trip DTC) concerning this diagnosis. Therefore, using CONSULT or ECM (Diagnostic Test Mode II) is recommended.



# DTC P0141 (RIGHT BANK, -B1), P0161 (LEFT BANK, -B2) REAR HEATED OXYGEN SENSOR HEATER

Wiring Diagram

## Wiring Diagram

RIGHT BANK

NEEC0117

NEEC0117S01

EC-RO2H-R-01

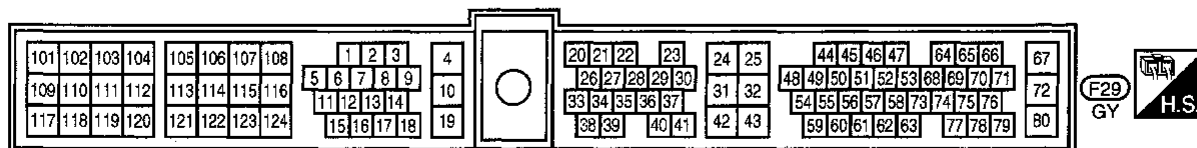
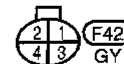
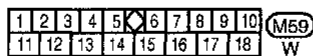
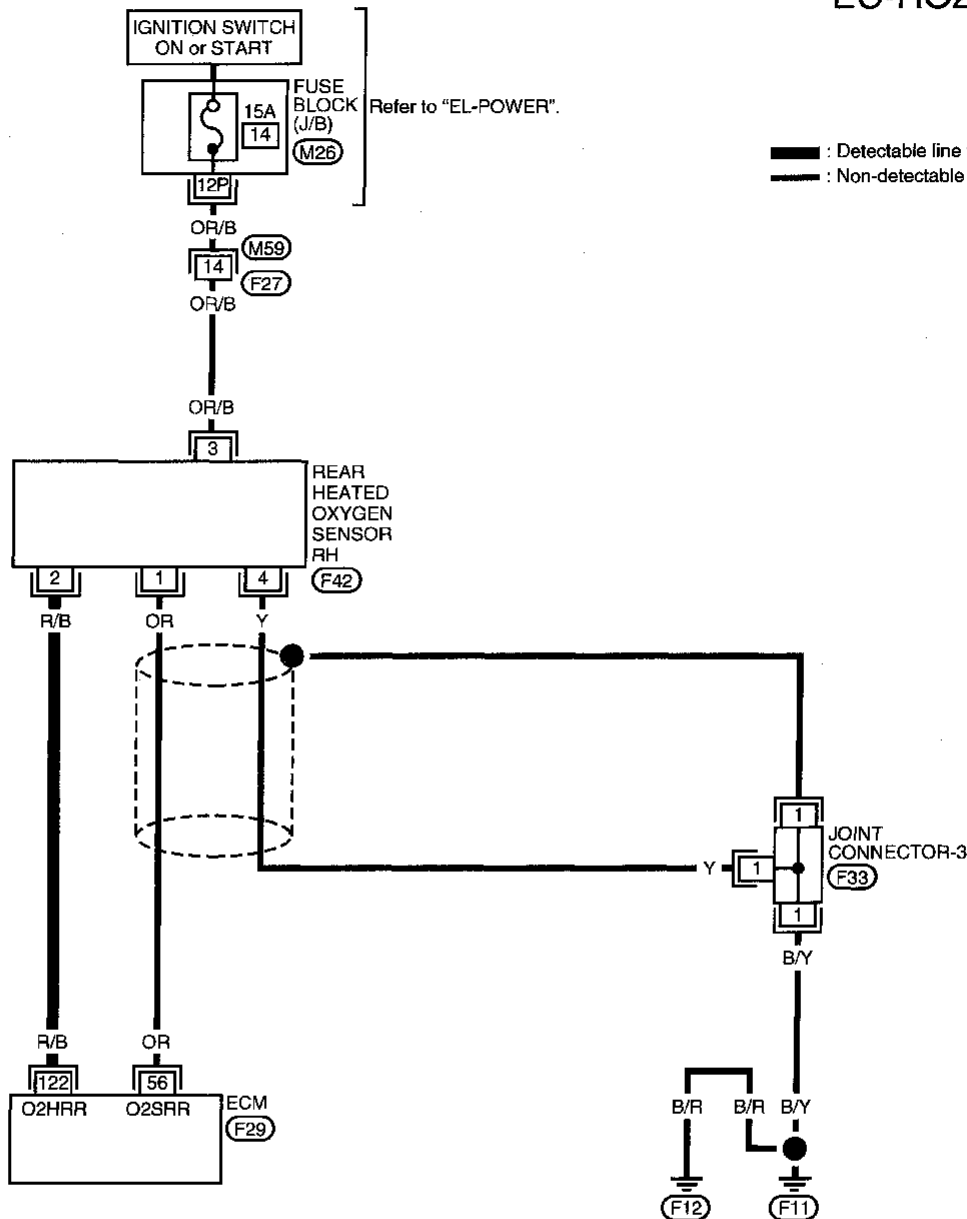

AEC735A

GI  
MA  
EM  
LC  
EC  
FE  
CL  
MT  
AT  
TF  
PD  
FA  
RA  
BR  
ST  
RS  
BT  
HA  
EL  
IDX

# DTC P0141 (RIGHT BANK, -B1), P0161 (LEFT BANK, -B2) REAR HEATED OXYGEN SENSOR HEATER

Wiring Diagram (Cont'd)

## LEFT BANK

NEEC0117S02

## EC-RO2H-L-01

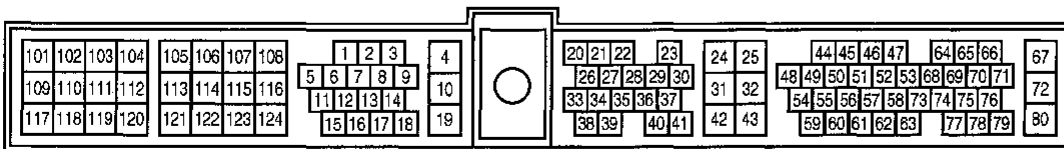
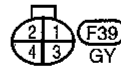
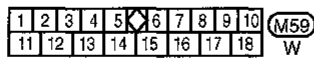
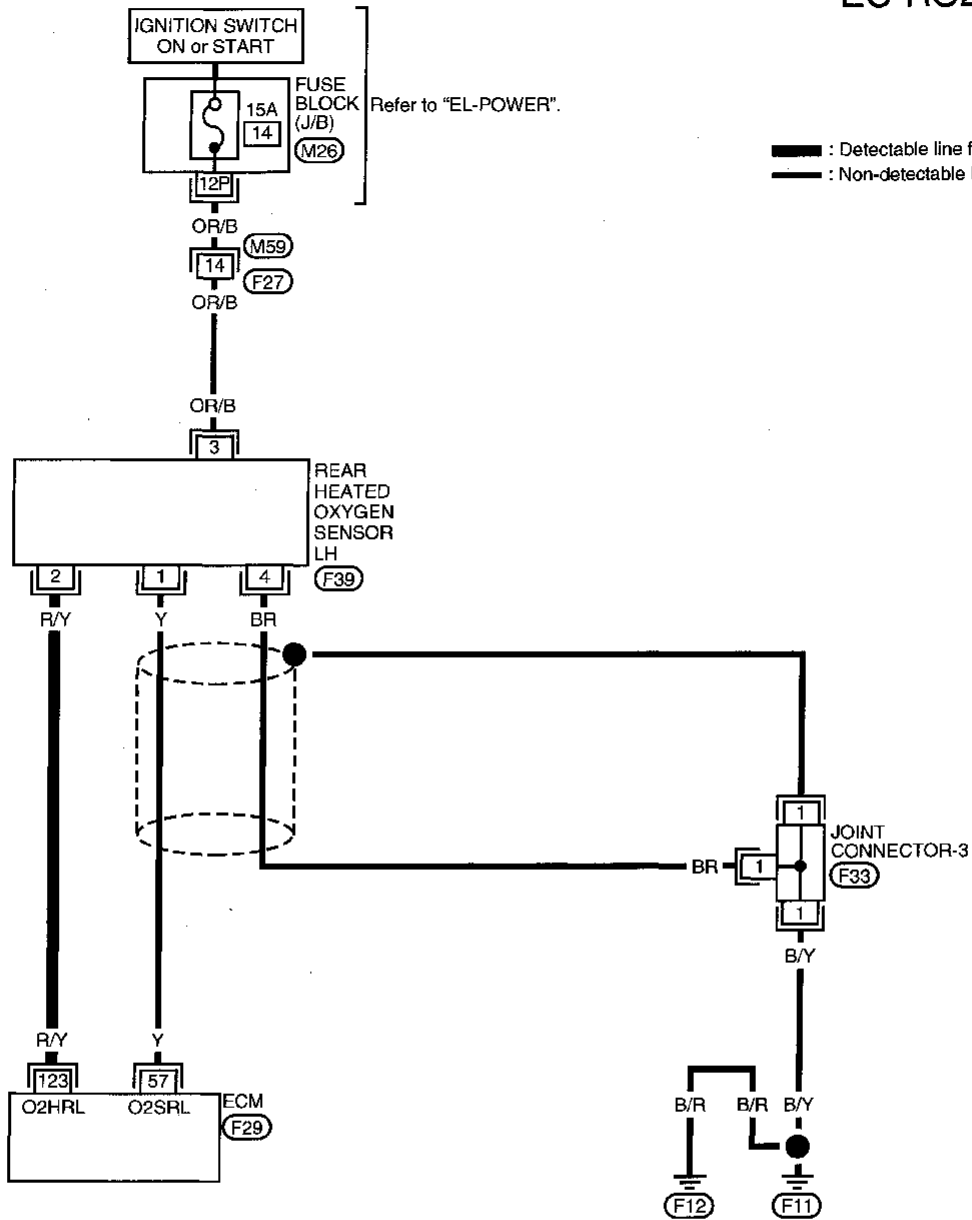

AEC736A

# DTC P0141 (RIGHT BANK, -B1), P0161 (LEFT BANK, -B2) REAR HEATED OXYGEN SENSOR HEATER

Diagnostic Procedure

NEEC0118

## Diagnostic Procedure

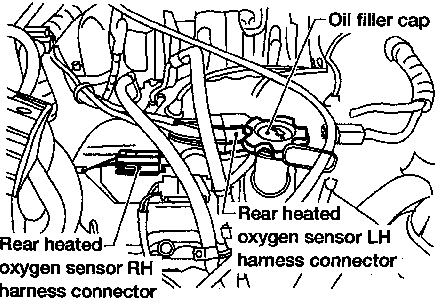
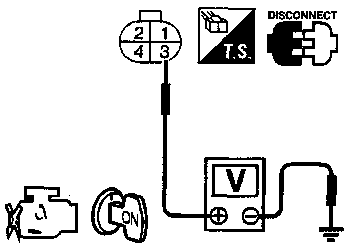
<b>1</b>	<b>CHECK POWER SUPPLY</b>
<ol style="list-style-type: none"> <li>Turn ignition switch "OFF".</li> <li>Disconnect corresponding rear heated oxygen sensor harness connector.</li> </ol>	
 <p style="text-align: right;">AEC645A</p>	
<ol style="list-style-type: none"> <li>Turn ignition switch "ON".</li> <li>Check voltage between terminal 3 and ground.</li> </ol>	
 <p style="text-align: center;">Voltage: Battery voltage</p> <p style="text-align: right;">SEF637W</p>	
OK or NG	
OK	▶ GO TO 3.
NG	▶ GO TO 2.

<b>2</b>	<b>DETECT MALFUNCTIONING PART</b>
Check the following. <ul style="list-style-type: none"> <li>Harness connectors M59, F27</li> <li>Fuse block (J/B) connector M26</li> <li>10A fuse</li> <li>Harness for open or short between rear heated oxygen sensor and fuse</li> </ul>	
▶ Repair harness or connectors.	

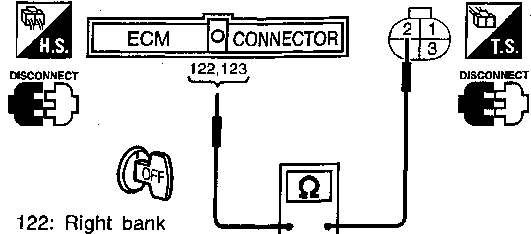
<b>3</b>	<b>CHECK GROUND CIRCUIT</b>														
<ol style="list-style-type: none"> <li>Turn ignition switch "OFF".</li> <li>Disconnect ECM harness connector.</li> <li>Check harness continuity between ECM terminal and sensor terminal as follows.</li> </ol>															
<table border="1" style="width: 100%;"> <thead> <tr> <th rowspan="2">DTC</th> <th colspan="2">Terminals</th> <th rowspan="2">Bank</th> </tr> <tr> <th>ECM</th> <th>Sensor</th> </tr> </thead> <tbody> <tr> <td>P0141</td> <td>122</td> <td>2</td> <td>Right</td> </tr> <tr> <td>P0161</td> <td>123</td> <td>2</td> <td>Left</td> </tr> </tbody> </table> <p style="text-align: right;">AEC903A</p>		DTC	Terminals		Bank	ECM	Sensor	P0141	122	2	Right	P0161	123	2	Left
DTC	Terminals		Bank												
	ECM	Sensor													
P0141	122	2	Right												
P0161	123	2	Left												
 <p style="text-align: center;">122: Right bank 123: Left bank</p> <p style="text-align: right;">SEF638W</p>															
Continuity should exist.															
4. Also check harness for short to ground and short to power.															
OK or NG															
OK	▶ GO TO 5.														
NG	▶ GO TO 4.														

<b>4</b>	<b>DETECT MALFUNCTIONING PART</b>
Check the following. <ul style="list-style-type: none"> <li>Joint connector-3</li> <li>Harness for open or short between rear heated oxygen sensor and engine ground.</li> </ul>	
▶ Repair open circuit or short to ground or short to power in harness or connectors.	

<b>5</b>	<b>CHECK REAR HEATED OXYGEN SENSOR HEATER</b>
Refer to "COMPONENT INSPECTION", EC-246.	
OK or NG	
OK	▶ GO TO 6.
NG	▶ Replace malfunctioning front heated oxygen sensor.

<b>6</b>	<b>CHECK INTERMITTENT INCIDENT</b>
Refer to "TROUBLE DIAGNOSIS FOR INTERMITTENT INCIDENT", EC-115.	
▶ INSPECTION END	

GI  
MA  
EM  
LC  
EC  
FE  
CL  
MT  
AT  
TF  
PD  
FA  
RA  
BR  
ST  
RS  
BT  
HA  
EL  
IDX

# DTC P0141 (RIGHT BANK, -B1), P0161 (LEFT BANK, -B2) REAR HEATED OXYGEN SENSOR HEATER

## Component Inspection

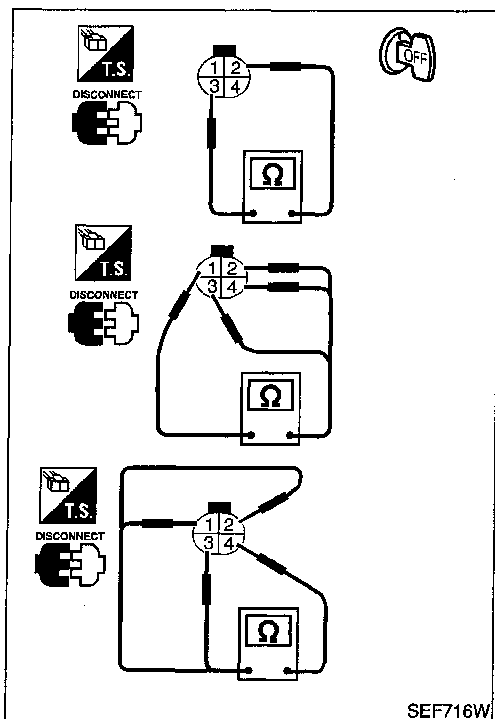

## Component Inspection

### REAR HEATED OXYGEN SENSOR HEATER

NEEC0119

NEEC0119S01

Check the following.

1. Check resistance between terminals 2 and 3.  
**Resistance: 2.3 - 4.3Ω at 25°C (77°F)**
2. Check continuity.

Terminal No.	Continuity
1 and 2, 3, 4	No
4 and 1, 2, 3	

If NG, replace the rear heated oxygen sensor.

#### CAUTION:

Discard any heated oxygen sensor which has been dropped from a height of more than 0.5 m (19.7 in) onto a hard surface such as a concrete floor; use a new one.

# DTC P0171 (RIGHT BANK, -B1), P0174 (LEFT BANK, -B2) FUEL INJECTION SYSTEM FUNCTION (LEAN SIDE)

On Board Diagnosis Logic

## On Board Diagnosis Logic

NEEC0150

With the Air/Fuel Mixture Ratio Self-Learning Control, the actual mixture ratio can be brought closely to the theoretical mixture ratio based on the mixture ratio feedback signal from the front heated oxygen sensors. The ECM calculates the necessary compensation to correct the offset between the actual and the theoretical ratios. In case the amount of the compensation value is extremely large (The actual mixture ratio is too lean.), the ECM judges the condition as the fuel injection system malfunction and light up the MIL (2 trip detection logic).

Sensor	Input Signal to ECM	ECM function	Actuator
Front heated oxygen sensors	Density of oxygen in exhaust gas (Mixture ratio feedback signal)	Fuel injection control	Injectors

DTC No.	Malfunction is detected when ...	Check Items (Possible Cause)
P0171 0115 (Right bank)	<ul style="list-style-type: none"> <li>Fuel injection system does not operate properly.</li> <li>The amount of mixture ratio compensation is too large. (The mixture ratio is too lean.)</li> </ul>	<ul style="list-style-type: none"> <li>Intake air leaks</li> <li>Front heated oxygen sensor</li> <li>Injectors</li> <li>Exhaust gas leaks</li> <li>Incorrect fuel pressure</li> <li>Lack of fuel</li> <li>Mass air flow sensor</li> </ul>
P0174 0210 (Left bank)		

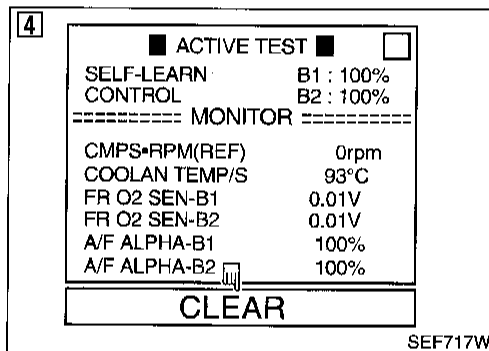

## DTC Confirmation Procedure

NEEC0151

### NOTE:

If "DTC Confirmation Procedure" has been previously conducted, always turn ignition switch "OFF" and wait at least 5 seconds before conducting the next test.

### Ⓟ With CONSULT

- Start engine and warm it up to normal operating temperature.
- Turn ignition switch "OFF" and wait at least 5 seconds.
- Turn ignition switch "ON" and select "SELF-LEARN CONTROL" in "ACTIVE TEST" mode with CONSULT.
- Clear the self-learning control coefficient by touching "CLEAR".
- Select "DATA MONITOR" mode with CONSULT.
- Start engine again and let it idle for at least 10 minutes. The 1st trip DTC P0171 or P0174 should be detected at this stage, if a malfunction exists. If so, go to "Diagnostic Procedure", EC-251.
- If it is difficult to start engine at step 6, the fuel injection system has a malfunction, too.
- Crank engine while depressing accelerator pedal. If engine starts, go to "Diagnostic Procedure", EC-251. If engine does not start, check exhaust and intake air leak visually.

### Ⓢ With GST

- Start engine and warm it up to normal operating temperature.
- Turn ignition switch "OFF" and wait at least 5 seconds.
- Disconnect mass air flow sensor harness connector. Then restart and run engine for at least 5 seconds at idle speed.
- Stop engine and reconnect mass air flow sensor harness connector.
- Select "MODE 7" with GST. Make sure 1st trip DTC P0100 is detected.
- Select "MODE 4" with GST and erase the 1st trip DTC P0100.
- Start engine again and let it idle for at least 10 minutes.

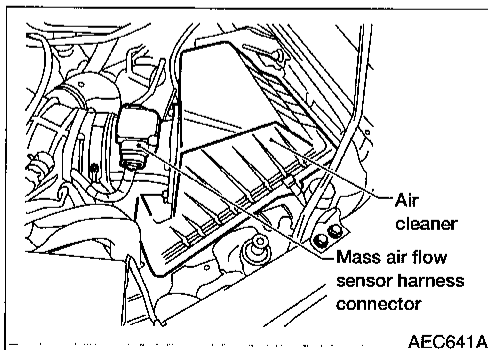

## DTC P0171 (RIGHT BANK, -B1), P0174 (LEFT BANK, -B2) FUEL INJECTION SYSTEM FUNCTION (LEAN SIDE)

DTC Confirmation Procedure (Cont'd)

---

- 8) Select "MODE 7" with GST. The 1st trip DTC P0171 or P0174 should be detected at this stage, if a malfunction exists. If so, go to "Diagnostic Procedure", EC-251.
- 9) If it is difficult to start engine at step 7, the fuel injection system has a malfunction.
- 10) Crank engine while depressing accelerator pedal. If engine starts, go to "Diagnostic Procedure", EC-251. If engine does not start, check exhaust and intake air leak visually.

### No Tools

- 1) Start engine and warm it up to normal operating temperature.
- 2) Turn ignition switch "OFF" and wait at least 5 seconds.
- 3) Disconnect mass air flow sensor harness connector. Then restart and run engine for at least 5 seconds at idle speed.
- 4) Stop engine and reconnect mass air flow sensor harness connector.
- 5) Turn ignition switch "ON".
- 6) Perform Diagnostic Test Mode II (Self-diagnostic results) with ECM. Make sure 1st trip DTC 0102 is detected.
- 7) Erase the 1st trip DTC 0102 by changing from Diagnostic Test Mode II to Diagnostic Test Mode I. Refer to "HOW TO ERASE EMISSION-RELATED DIAGNOSTIC INFORMATION", EC-56.
- 8) Perform Diagnostic Test Mode II (Self-diagnostic results) with ECM. Make sure DTC 0505 is detected.
- 9) Start engine again and let it idle for at least 10 minutes. The 1st trip DTC 0115 should be detected at this stage, if a malfunction exists. If so, go to "Diagnostic Procedure", EC-251.
- 10) If it is difficult to start engine at step 9, the fuel injection system also has a malfunction.
- 11) Crank engine while depressing accelerator pedal. If engine starts, go to "Diagnostic Procedure", EC-251. If engine does not start, check exhaust and intake air leak visually.

# DTC P0171 (RIGHT BANK, -B1), P0174 (LEFT BANK, -B2) FUEL INJECTION SYSTEM FUNCTION (LEAN SIDE)

Wiring Diagram

## Wiring Diagram

### RIGHT BANK

NEEC0152

NEEC0152S01

### EC-FUELRH-01

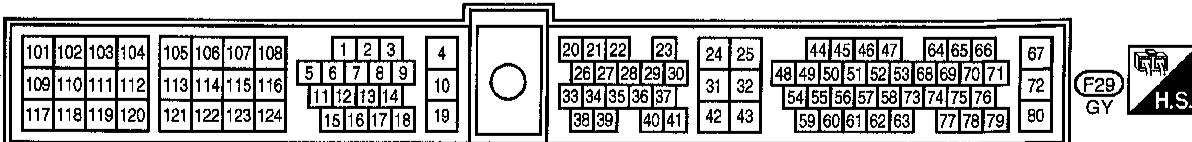
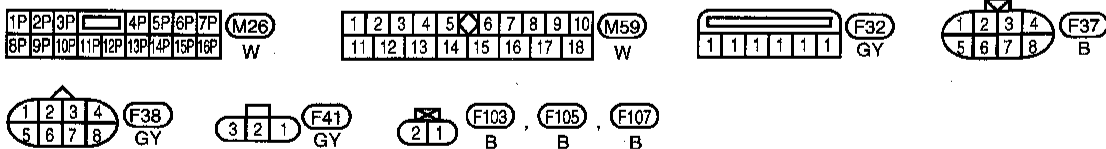
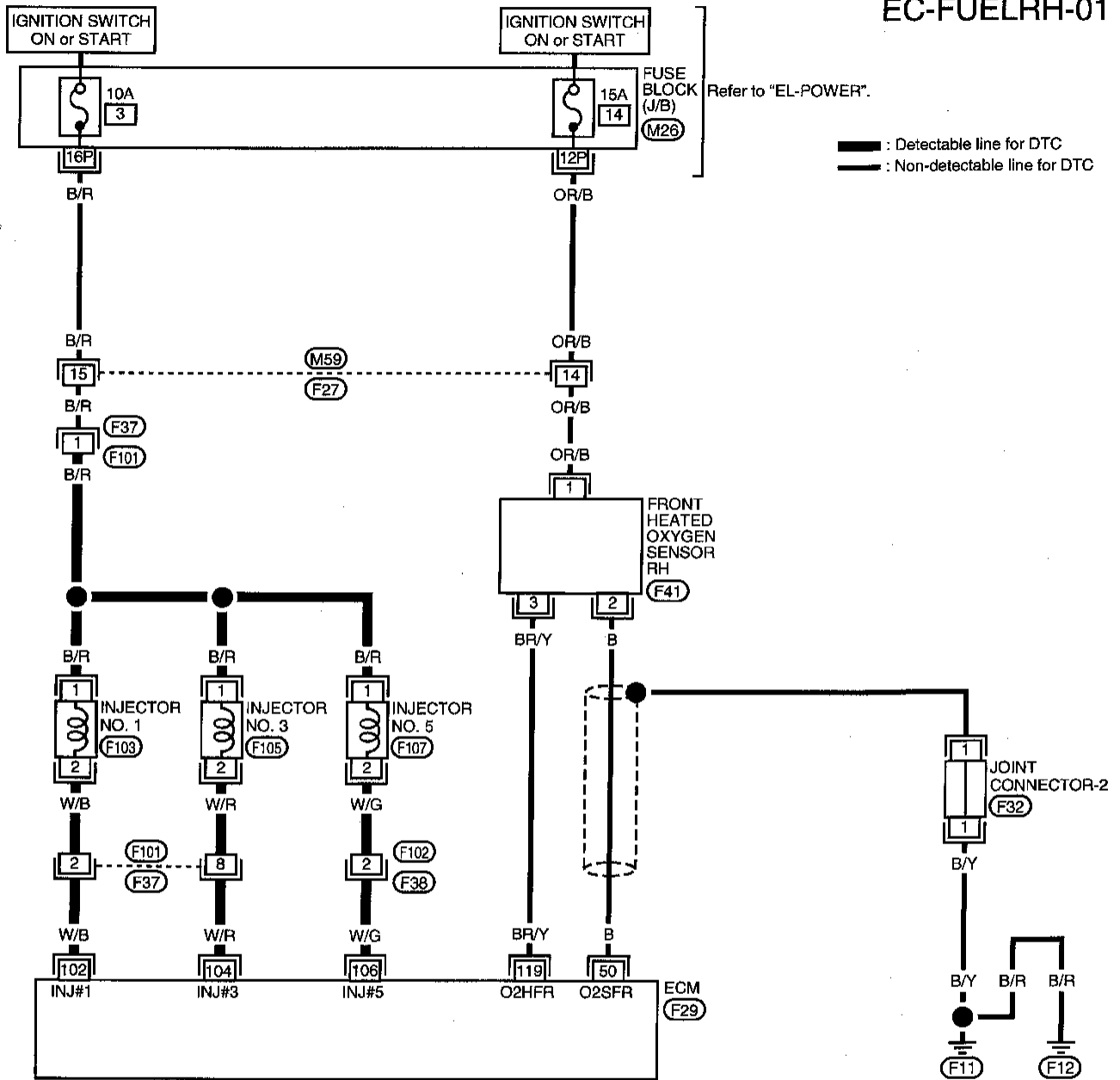

AEC737A

# DTC P0171 (RIGHT BANK, -B1), P0174 (LEFT BANK, -B2) FUEL INJECTION SYSTEM FUNCTION (LEAN SIDE)

Wiring Diagram (Cont'd)

## LEFT BANK

NEEC0152S02

EC-FUELLH-01

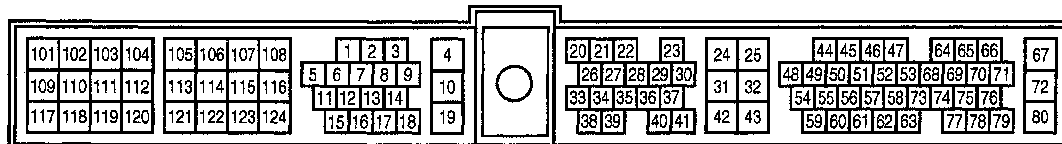
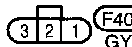
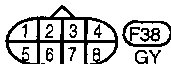
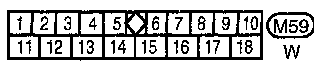
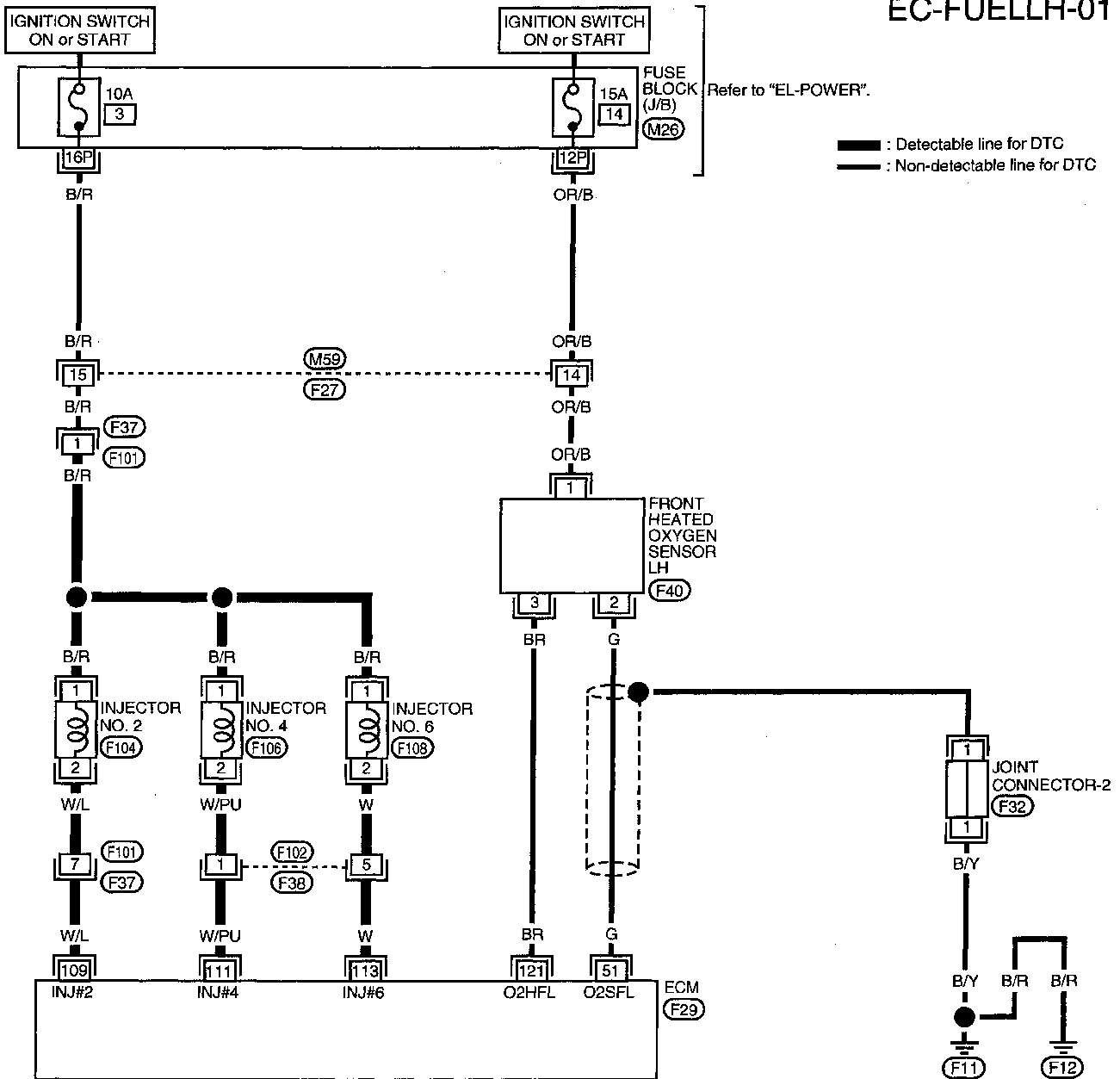

AEC738A



# DTC P0171 (RIGHT BANK, -B1), P0174 (LEFT BANK, -B2) FUEL INJECTION SYSTEM FUNCTION (LEAN SIDE)

Diagnostic Procedure

## Diagnostic Procedure

NEEC0153

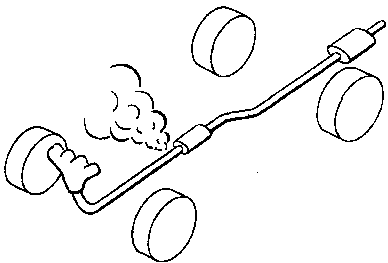
<b>1</b>	<b>CHECK EXHAUST AIR LEAK</b>
<ol style="list-style-type: none"> <li>1. Start engine and run it at idle.</li> <li>2. Listen for an exhaust air leak before three way catalyst.</li> </ol>	
	
SEF099P	
<b>OK or NG</b>	
OK	▶ GO TO 2.
NG	▶ Repair or replace.

<b>2</b>	<b>CHECK FOR INTAKE AIR LEAK</b>
Listen for an intake air leak after the mass air flow sensor.	
<b>OK or NG</b>	
OK	▶ GO TO 3.
NG	▶ Repair or replace.

<b>3</b>	<b>CHECK FRONT HEATED OXYGEN SENSOR CIRCUIT-I</b>
<ol style="list-style-type: none"> <li>1. Turn ignition switch "OFF".</li> <li>2. Disconnect corresponding front heated oxygen sensor harness connector.</li> <li>3. Disconnect ECM harness connector.</li> </ol>	
▶ GO TO 4.	

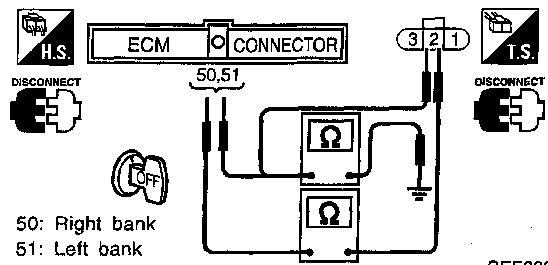
<b>4</b>	<b>CHECK FRONT HEATED OXYGEN SENSOR CIRCUIT-II</b>														
1. Check harness continuity between ECM terminal and sensor terminal as follows.															
<table border="1"> <thead> <tr> <th rowspan="2">DTC</th> <th colspan="2">Terminals</th> <th rowspan="2">Bank</th> </tr> <tr> <th>ECM</th> <th>Sensor</th> </tr> </thead> <tbody> <tr> <td>P0171</td> <td>50</td> <td>2</td> <td>Right</td> </tr> <tr> <td>P0174</td> <td>51</td> <td>2</td> <td>Left</td> </tr> </tbody> </table>		DTC	Terminals		Bank	ECM	Sensor	P0171	50	2	Right	P0174	51	2	Left
DTC	Terminals		Bank												
	ECM	Sensor													
P0171	50	2	Right												
P0174	51	2	Left												
AEC904A															
															
SEF632W															
<b>Continuity should exist.</b>															
2. Check harness continuity between ECM terminal or sensor terminal and ground as follows.															
<table border="1"> <thead> <tr> <th rowspan="2">DTC</th> <th colspan="2">Terminals</th> <th rowspan="2">Bank</th> </tr> <tr> <th>ECM or sensor</th> <th>Ground</th> </tr> </thead> <tbody> <tr> <td>P0171</td> <td>50 or 2</td> <td>Ground</td> <td>Right</td> </tr> <tr> <td>P0174</td> <td>51 or 2</td> <td>Ground</td> <td>Left</td> </tr> </tbody> </table>		DTC	Terminals		Bank	ECM or sensor	Ground	P0171	50 or 2	Ground	Right	P0174	51 or 2	Ground	Left
DTC	Terminals		Bank												
	ECM or sensor	Ground													
P0171	50 or 2	Ground	Right												
P0174	51 or 2	Ground	Left												
AEC905A															
<b>Continuity should not exist.</b>															
3. Also check harness for short to power.															
<b>OK or NG</b>															
OK	▶ GO TO 5.														
NG	▶ Repair open circuit or short to ground or short to power in harness or connectors.														

<b>5</b>	<b>CHECK FUEL PRESSURE</b>
<ol style="list-style-type: none"> <li>1. Release fuel pressure to zero. Refer to EC-31.</li> <li>2. Install fuel pressure gauge and check fuel pressure. <b>At idling:</b>  <ul style="list-style-type: none"> <li>When fuel pressure regulator valve vacuum hose is connected. 235 kPa (2.4 kg/cm<sup>2</sup>, 34 psi)</li> <li>When fuel pressure regulator valve vacuum hose is disconnected. 294 kPa (3.0 kg/cm<sup>2</sup>, 43 psi)</li> </ul> </li> </ol>	
<b>OK or NG</b>	
OK	▶ GO TO 7.
NG	▶ GO TO 6.

# DTC P0171 (RIGHT BANK, -B1), P0174 (LEFT BANK, -B2) FUEL INJECTION SYSTEM FUNCTION (LEAN SIDE)

Diagnostic Procedure (Cont'd)

<b>6</b>	<b>DETECT MALFUNCTIONING PART</b>
<p>Check the following.</p> <ul style="list-style-type: none"> <li>• Fuel pump and circuit (Refer to EC-467.)</li> <li>• Fuel pressure regulator (Refer to EC-32.)</li> <li>• Fuel lines (Refer to "ENGINE MAINTENANCE" in MA section.)</li> <li>• Fuel filter for clogging</li> </ul>	
▶ Repair or replace.	

<b>7</b>	<b>CHECK MASS AIR FLOW SENSOR</b>
<p><b>With CONSULT</b></p> <ol style="list-style-type: none"> <li>1. Install all parts removed.</li> <li>2. Check "MASS AIR FLOW" in "DATA MONITOR" mode with CONSULT. <ul style="list-style-type: none"> <li>3.3 - 4.8 g-m/sec: at idling</li> <li>12.0 - 14.9 g-m/sec: at 2,500 rpm</li> </ul> </li> </ol>	
<p><b>With GST</b></p> <ol style="list-style-type: none"> <li>1. Install all parts removed.</li> <li>2. Check mass air flow sensor signal in MODE 1 with GST. <ul style="list-style-type: none"> <li>3.3 - 4.8 g-m/sec: at idling</li> <li>12.0 - 14.9 g-m/sec: at 2,500 rpm</li> </ul> </li> </ol>	
<p><b>No Tools</b></p> <ol style="list-style-type: none"> <li>1. Install all parts removed.</li> <li>2. Check voltage between ECM terminal 54 and ground. <ul style="list-style-type: none"> <li>1.0 - 1.7V: at idling</li> <li>1.7 - 2.3V: at 2,500 rpm</li> </ul> </li> </ol> <p style="text-align: center;"><b>OK or NG</b></p>	
OK	▶ GO TO 8.
NG	▶ Check connectors for rusted terminals or loose connections in the mass air flow sensor circuit or engine grounds. Refer to EC-121.

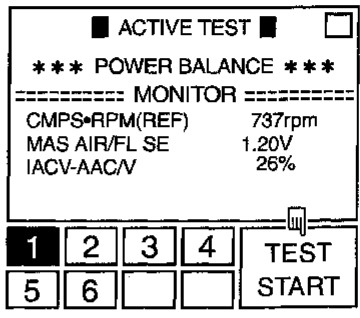
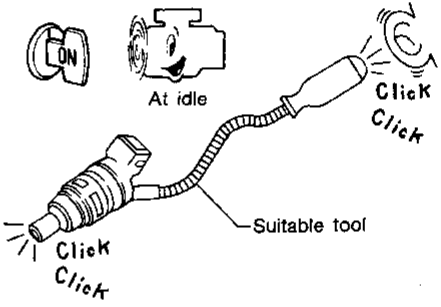
<b>8</b>	<b>CHECK FUNCTION OF INJECTORS</b>
<p><b>With CONSULT</b></p> <ol style="list-style-type: none"> <li>1. Start engine.</li> <li>2. Perform "POWER BALANCE" in "ACTIVE TEST" mode with CONSULT.</li> </ol>	
	
SEF389V	
<ol style="list-style-type: none"> <li>3. Make sure that each circuit produces a momentary engine speed drop.</li> </ol>	
<p><b>Without CONSULT</b></p> <ol style="list-style-type: none"> <li>1. Start engine.</li> <li>2. Listen to each injector operating sound.</li> </ol>	
	
<p><b>Clicking noise should be heard.</b></p> <p style="text-align: center;"><b>OK or NG</b></p>	
OK	▶ GO TO 9.
NG	▶ Perform trouble diagnosis for "INJECTORS", EC-460.

# DTC P0171 (RIGHT BANK, -B1), P0174 (LEFT BANK, -B2) FUEL INJECTION SYSTEM FUNCTION (LEAN SIDE)

Diagnostic Procedure (Cont'd)

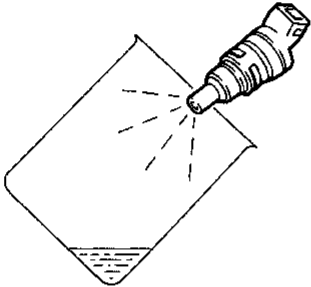
<b>9</b>	<b>CHECK INJECTOR</b>	
<ol style="list-style-type: none"> <li>1. Confirm that the engine is cooled down and there are no fire hazards near the vehicle.</li> <li>2. Turn ignition switch "OFF".</li> <li>3. Disconnect injector harness connectors on left bank (for DTC P0171), right bank (for DTC P0174).</li> <li>4. Remove injector gallery assembly. Refer to EC-32. Keep fuel hose and all injectors connected to injector gallery. The injector harness connectors on right bank (for DTC P0171), left bank (for DTC P0174) should remain connected.</li> <li>5. Disconnect all ignition coil harness connectors.</li> <li>6. Prepare pans or saucers under each injector.</li> <li>7. Crank engine for about 3 seconds. Make sure that fuel sprays out from injectors.</li> </ol>		
 <p style="text-align: right; margin-right: 50px;">SEF595Q</p> <p><b>Fuel should be sprayed evenly for each injector.</b></p> <p><b>OK or NG</b></p>		
OK	▶	GO TO 10.
NG	▶	Replace injectors from which fuel does not spray out. Always replace O-ring with new ones.

<b>10</b>	<b>CHECK INTERMITTENT INCIDENT</b>	
Refer to "TROUBLE DIAGNOSIS FOR INTERMITTENT INCIDENT", EC-115.		
▶		<b>INSPECTION END</b>

GI  
MA  
EM  
LC  
**EC**  
FE  
CL  
MT  
AT  
TF  
PD  
FA  
RA  
BR  
ST  
RS  
BT  
HA  
EL  
IDX

# DTC P0172 (RIGHT BANK, -B1), P0175 (LEFT BANK, -B2) FUEL INJECTION SYSTEM FUNCTION (RICH SIDE)

On Board Diagnosis Logic

## On Board Diagnosis Logic

NEEC0154

With the Air/Fuel Mixture Ratio Self-Learning Control, the actual mixture ratio can be brought closely to the theoretical mixture ratio based on the mixture ratio feedback signal from the front heated oxygen sensors. The ECM calculates the necessary compensation to correct the offset between the actual and the theoretical ratios. In case the amount of the compensation value is extremely large (The actual mixture ratio is too rich.), the ECM judges the condition as the fuel injection system malfunction and light up the MIL (2 trip detection logic).

Sensor	Input Signal to ECM	ECM function	Actuator
Front heated oxygen sensors	Density of oxygen in exhaust gas (Mixture ratio feedback signal)	Fuel injection control	Injectors

DTC No.	Malfunction is detected when ...	Check Items (Possible Cause)
P0172 0114 (Right bank)	<ul style="list-style-type: none"> <li>Fuel injection system does not operate properly.</li> <li>The amount of mixture ratio compensation is too large. (The mixture ratio is too rich.)</li> </ul>	<ul style="list-style-type: none"> <li>Front heated oxygen sensor</li> <li>Injectors</li> <li>Exhaust gas leaks</li> <li>Incorrect fuel pressure</li> <li>Mass air flow sensor</li> </ul>
P0175 0209 (Left bank)		

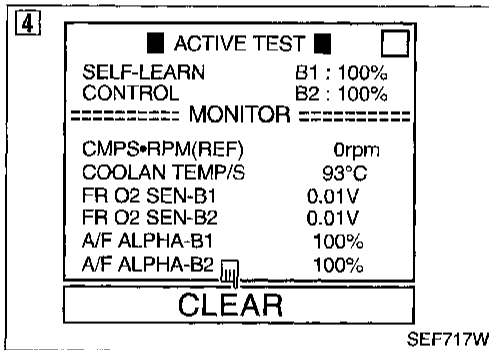

## DTC Confirmation Procedure

NEEC0155

### NOTE:

If "DTC Confirmation Procedure" has been previously conducted, always turn ignition switch "OFF" and wait at least 5 seconds before conducting the next test.

### ④ With CONSULT

- 1) Start engine and warm it up to normal operating temperature.
- 2) Turn ignition switch "OFF" and wait at least 5 seconds.
- 3) Turn ignition switch "ON" and select "SELF-LEARN CONTROL" in "ACTIVE TEST" mode with CONSULT.
- 4) Clear the self-learning control coefficient by touching "CLEAR".
- 5) Select "DATA MONITOR" mode with CONSULT.
- 6) Start engine again and let it idle for at least 10 minutes. The 1st trip DTC P0172, P0175 should be detected at this stage, if a malfunction exists. If so, go to "Diagnostic Procedure", EC-258.
- 7) If it is difficult to start engine at step 6, the fuel injection system has a malfunction, too.
- 8) Crank engine while depressing accelerator pedal. If engine starts, go to "Diagnostic Procedure", EC-258. If engine does not start, remove ignition plugs and check for fouling, etc.

### ④ With GST

- 1) Start engine and warm it up to normal operating temperature.
- 2) Turn ignition switch "OFF" and wait at least 5 seconds.
- 3) Disconnect mass air flow sensor harness connector. Then restart and run engine for at least 5 seconds at idle speed.
- 4) Stop engine and reconnect mass air flow sensor harness connector.
- 5) Select "MODE 7" with GST. Make sure 1st trip DTC P0100 is detected.
- 6) Select "MODE 4" with GST and erase the 1st trip DTC P0100.
- 7) Start engine again and let it idle for at least 10 minutes.

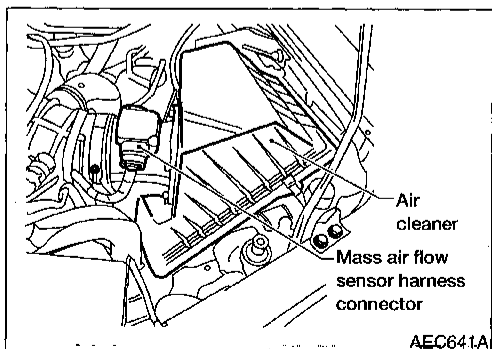

## EC-254

# DTC P0172 (RIGHT BANK, -B1), P0175 (LEFT BANK, -B2) FUEL INJECTION SYSTEM FUNCTION (RICH SIDE)

DTC Confirmation Procedure (Cont'd)

- 8) Select "MODE 7" with GST. The 1st trip DTC P0172 or P0175 should be detected at this stage, if a malfunction exists. If so, go to "Diagnostic Procedure", EC-258. GI
- 9) If it is difficult to start engine at step 7, the fuel injection system has a malfunction. MA
- 10) Crank engine while depressing accelerator pedal. If engine starts, go to "Diagnostic Procedure", EC-258. If engine does not start, check exhaust and intake air leak visually. EM

 **No Tools**

- 1) Disconnect mass air flow sensor harness connector. LC
- 2) Start engine and run it for at least 5 seconds at idle speed. EC
- 3) Stop engine and reconnect mass air flow sensor harness connector.
- 4) Turn ignition switch "ON".
- 5) Perform Diagnostic Test Mode II (Self-diagnostic results) with ECM. Make sure 1st trip DTC 0102 is detected. FE
- 6) Erase the 1st trip DTC 0102 by changing from Diagnostic Test Mode II to Diagnostic Test Mode I. Refer to "HOW TO ERASE EMISSION-RELATED DIAGNOSTIC INFORMATION", EC-56. CL
- 7) Perform Diagnostic Test Mode II (Self-diagnostic results) with ECM. Make sure DTC 0505 is detected. MT
- 8) Start engine again and let it idle for at least 10 minutes. The 1st trip DTC 0114 or 0209 should be detected at this stage, if a malfunction exists. If so, go to "Diagnostic Procedure", EC-258. AT
- 9) If it is difficult to start engine at step 8, the fuel injection system also has a malfunction. TF
- 10) Crank engine while depressing accelerator pedal. If engine starts, go to "Diagnostic Procedure", EC-258. If engine does not start, remove ignition plugs and check for fouling, etc. PD

GI  
MA  
EM  
LC  
EC  
FE  
CL  
MT  
AT  
TF  
PD  
FA  
RA  
BR  
ST  
RS  
BT  
HA  
EL  
IDX

# DTC P0172 (RIGHT BANK, -B1), P0175 (LEFT BANK, -B2) FUEL INJECTION SYSTEM FUNCTION (RICH SIDE)

Wiring Diagram

## Wiring Diagram

NEEC0156

NEEC0156S01

### EC-FUEL RH-01

#### RIGHT BANK

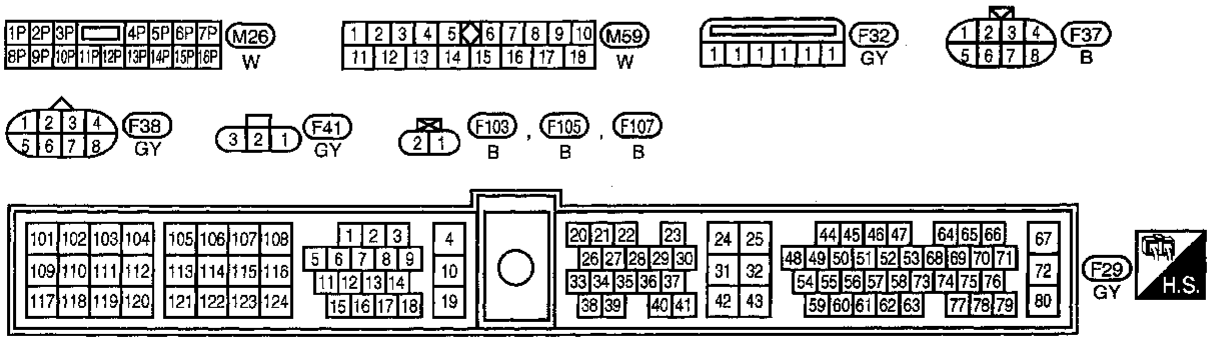
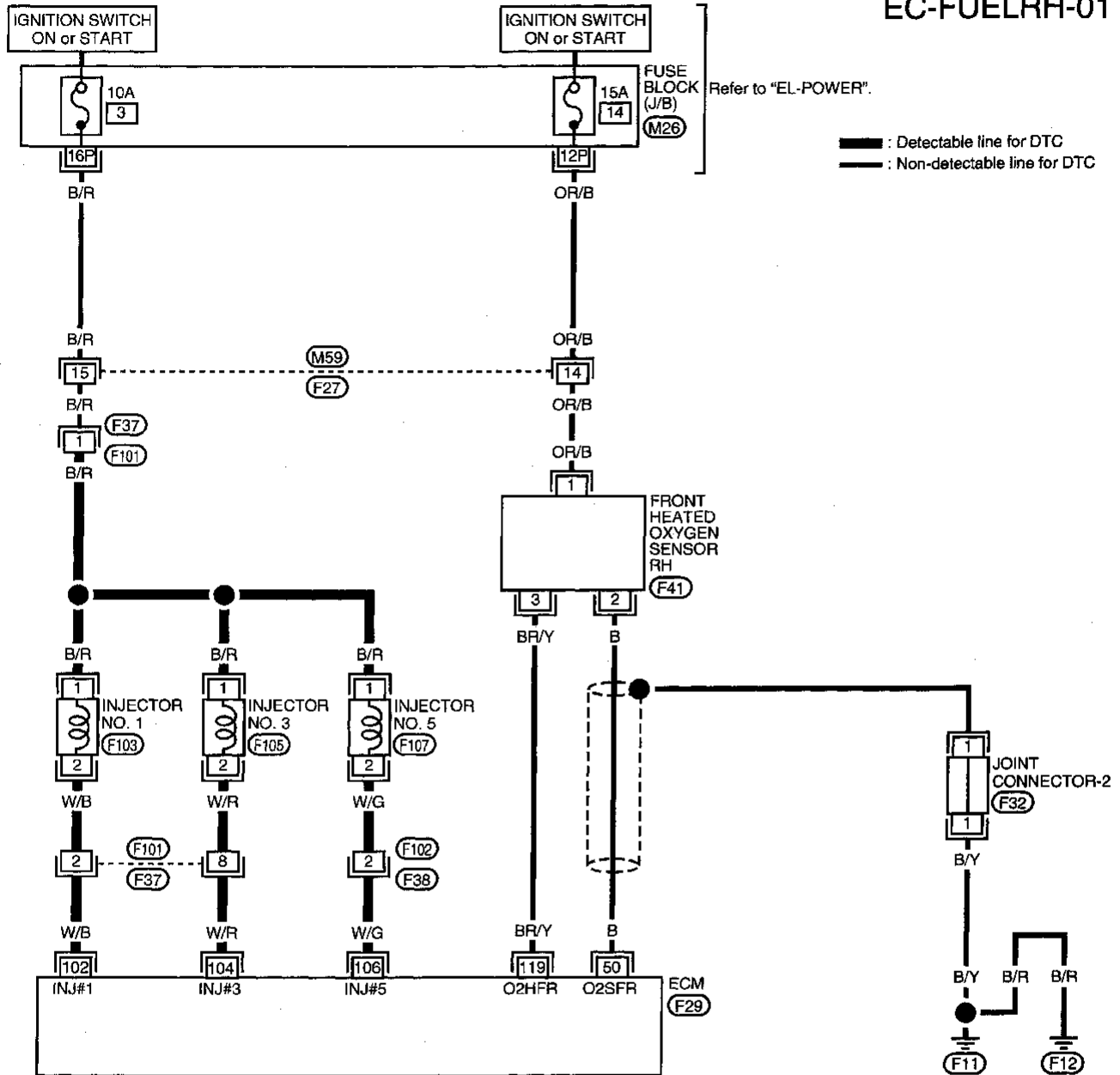

AEC737A

# DTC P0172 (RIGHT BANK, -B1), P0175 (LEFT BANK, -B2) FUEL INJECTION SYSTEM FUNCTION (RICH SIDE)

Wiring Diagram (Cont'd)

## LEFT BANK

NEEC0166S02

## EC-FUELLH-01

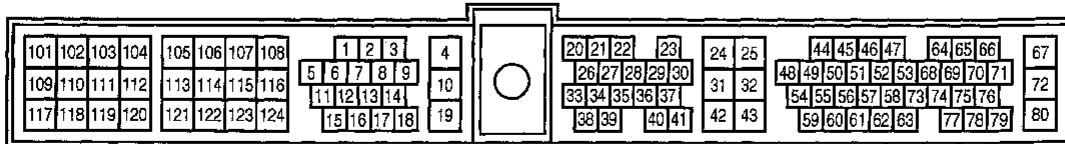
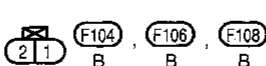
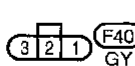
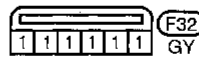
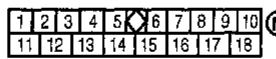
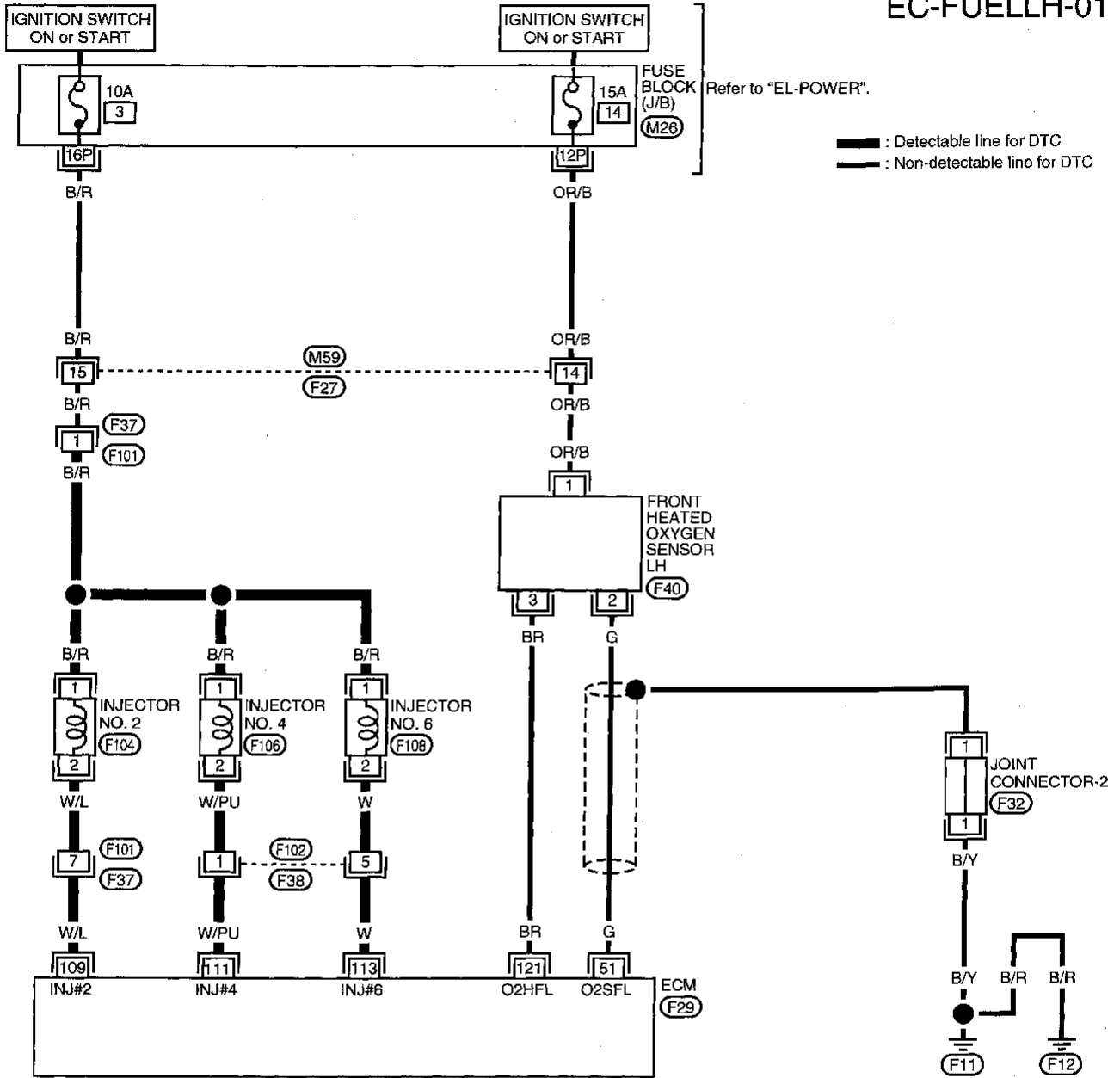

AEC738A

# DTC P0172 (RIGHT BANK, -B1), P0175 (LEFT BANK, -B2) FUEL INJECTION SYSTEM FUNCTION (RICH SIDE)

Diagnostic Procedure

## Diagnostic Procedure

NEEC0157

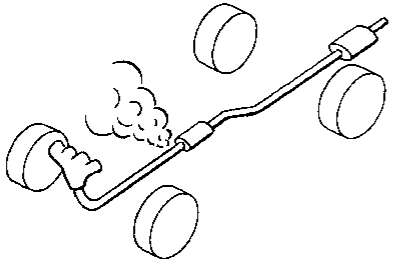
<b>1</b>	<b>CHECK EXHAUST AIR LEAK</b>
1. Start engine and run it at idle. 2. Listen for an exhaust air leak before three way catalyst.	
	
<b>OK or NG</b>	
OK	▶ GO TO 2.
NG	▶ Repair or replace.

<b>2</b>	<b>CHECK FOR INTAKE AIR LEAK</b>
Listen for an intake air leak after the mass air flow sensor.	
<b>OK or NG</b>	
OK	▶ GO TO 3.
NG	▶ Repair or replace.

<b>3</b>	<b>CHECK FRONT HEATED OXYGEN SENSOR CIRCUIT-I</b>
1. Turn ignition switch "OFF". 2. Disconnect corresponding front heated oxygen sensor harness connector. 3. Disconnect ECM harness connector.	
▶ GO TO 4.	

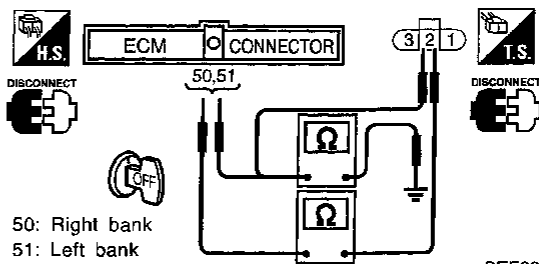
<b>4</b>	<b>CHECK FRONT HEATED OXYGEN SENSOR CIRCUIT-II</b>														
1. Check harness continuity between ECM terminal and sensor terminal as follows.															
<table border="1" style="width: 100%;"> <thead> <tr> <th rowspan="2">DTC</th> <th colspan="2">Terminals</th> <th rowspan="2">Bank</th> </tr> <tr> <th>ECM</th> <th>Sensor</th> </tr> </thead> <tbody> <tr> <td>P0172</td> <td>50</td> <td>2</td> <td>Right</td> </tr> <tr> <td>P0175</td> <td>51</td> <td>2</td> <td>Left</td> </tr> </tbody> </table> <p style="text-align: right;">AEC906A</p>		DTC	Terminals		Bank	ECM	Sensor	P0172	50	2	Right	P0175	51	2	Left
DTC	Terminals		Bank												
	ECM	Sensor													
P0172	50	2	Right												
P0175	51	2	Left												
															
50: Right bank 51: Left bank															
<b>Continuity should exist.</b>															
2. Check harness continuity between ECM terminal or sensor terminal and ground as follows.															
<table border="1" style="width: 100%;"> <thead> <tr> <th rowspan="2">DTC</th> <th colspan="2">Terminals</th> <th rowspan="2">Bank</th> </tr> <tr> <th>ECM or sensor</th> <th>Ground</th> </tr> </thead> <tbody> <tr> <td>P0172</td> <td>50 or 2</td> <td>Ground</td> <td>Right</td> </tr> <tr> <td>P0175</td> <td>51 or 2</td> <td>Ground</td> <td>Left</td> </tr> </tbody> </table> <p style="text-align: right;">AEC907A</p>		DTC	Terminals		Bank	ECM or sensor	Ground	P0172	50 or 2	Ground	Right	P0175	51 or 2	Ground	Left
DTC	Terminals		Bank												
	ECM or sensor	Ground													
P0172	50 or 2	Ground	Right												
P0175	51 or 2	Ground	Left												
<b>Continuity should not exist.</b>															
3. Also check harness for short to power.															
<b>OK or NG</b>															
OK	▶ GO TO 5.														
NG	▶ Repair open circuit or short to ground or short to power in harness or connectors.														

<b>5</b>	<b>CHECK FUEL PRESSURE</b>
1. Release fuel pressure to zero. Refer to EC-31.	
2. Install fuel pressure gauge and check fuel pressure.	
<b>At idling:</b> <b>When fuel pressure regulator valve vacuum hose is connected.</b> 235 kPa (2.4 kg/cm <sup>2</sup> , 34 psi) <b>When fuel pressure regulator valve vacuum hose is disconnected.</b> 294 kPa (3.0 kg/cm <sup>2</sup> , 43 psi)	
<b>OK or NG</b>	
OK	▶ GO TO 7.
NG	▶ GO TO 6.



# DTC P0172 (RIGHT BANK, -B1), P0175 (LEFT BANK, -B2) FUEL INJECTION SYSTEM FUNCTION (RICH SIDE)

Diagnostic Procedure (Cont'd)

<b>6</b>	<b>DETECT MALFUNCTIONING PART</b>
Check the following. <ul style="list-style-type: none"> <li>Fuel pump and circuit (Refer to EC-467.)</li> <li>Fuel pressure regulator (Refer to EC-32.)</li> </ul>	
▶	Repair or replace.

<b>7</b>	<b>CHECK MASS AIR FLOW SENSOR</b>
With CONSULT <ol style="list-style-type: none"> <li>Install all parts removed.</li> <li>Check "MASS AIR FLOW" in "DATA MONITOR" mode with CONSULT.                         <ul style="list-style-type: none"> <li>3.3 - 4.8 g-m/sec: at idling</li> <li>12.0 - 14.9 g-m/sec: at 2,500 rpm</li> </ul> </li> </ol>	
With GST <ol style="list-style-type: none"> <li>Install all parts removed.</li> <li>Check mass air flow sensor signal in MODE 1 with GST.                         <ul style="list-style-type: none"> <li>3.3 - 4.8 g-m/sec: at idling</li> <li>12.0 - 14.9 g-m/sec: at 2,500 rpm</li> </ul> </li> </ol>	
No Tools <ol style="list-style-type: none"> <li>Install all parts removed.</li> <li>Check voltage between ECM terminal 54 and ground.                         <ul style="list-style-type: none"> <li>1.0 - 1.7V: at idling</li> <li>1.7 - 2.3V: at 2,500 rpm</li> </ul> </li> </ol> <p style="text-align: center;">OK or NG</p>	
OK	▶ GO TO 8.
NG	▶ Check connectors for rusted terminals or loose connections in the mass air flow sensor circuit or engine grounds. Refer to EC-121.

<b>8</b>	<b>CHECK FUNCTION OF INJECTORS</b>						
With CONSULT <ol style="list-style-type: none"> <li>Start engine.</li> <li>Perform "POWER BALANCE" in "ACTIVE TEST" mode with CONSULT.                         <div style="border: 1px solid black; padding: 5px; margin: 10px 0;"> <div style="text-align: center;"> <span style="font-size: 1.2em;">■</span> ACTIVE TEST <span style="font-size: 1.2em;">□</span> </div> <div style="text-align: center;"> <b>*** POWER BALANCE ***</b> </div> <div style="text-align: center;">                     ===== MONITOR =====                 </div> <table style="width: 100%; border-collapse: collapse;"> <tr> <td style="border-bottom: 1px solid black;">CMPS•RPM(REF)</td> <td style="border-bottom: 1px solid black; text-align: right;">737rpm</td> </tr> <tr> <td style="border-bottom: 1px solid black;">MAS AIR/FL SE</td> <td style="border-bottom: 1px solid black; text-align: right;">1.20V</td> </tr> <tr> <td style="border-bottom: 1px solid black;">IACV-AAC/V</td> <td style="border-bottom: 1px solid black; text-align: right;">26%</td> </tr> </table> <div style="text-align: right; margin-top: 5px;"> <input type="checkbox"/> </div> </div> </li> </ol>		CMPS•RPM(REF)	737rpm	MAS AIR/FL SE	1.20V	IACV-AAC/V	26%
CMPS•RPM(REF)	737rpm						
MAS AIR/FL SE	1.20V						
IACV-AAC/V	26%						
Without CONSULT <ol style="list-style-type: none"> <li>Start engine.</li> <li>Listen to each injector operating sound.</li> </ol>							
Clicking noise should be heard.							
OK or NG							
OK	▶ GO TO 9.						
NG	▶ Perform trouble diagnosis for "INJECTORS", EC-460.						

GI  
MA  
EM  
LC  
EC  
FE  
CL  
MT  
AT  
TF  
PD  
FA  
RA  
BR  
ST  
RS  
BT  
HA  
EL  
IDX

# DTC P0172 (RIGHT BANK, -B1), P0175 (LEFT BANK, -B2) FUEL INJECTION SYSTEM FUNCTION (RICH SIDE)

*Diagnostic Procedure (Cont'd)*

<b>9</b>	<b>CHECK INJECTOR</b>	
<ol style="list-style-type: none"> <li>1. Remove injector assembly. Refer to EC-32. Keep fuel hose and all injectors connected to injector gallery.</li> <li>2. Confirm that the engine is cooled down and there are no fire hazards near the vehicle.</li> <li>3. Disconnect injector harness connectors left bank (for DTC P0172), right bank (for P0175). The injector harness connectors on right bank (for P0172), left bank (for P0175) should remain connected.</li> <li>4. Disconnect all ignition coil harness connectors.</li> <li>5. Prepare pans or saucers under each injectors.</li> <li>6. Crank engine for about 3 seconds. Make sure fuel does not drip from injector.</li> </ol>		
<b>OK or NG</b>		
OK (Does not drip)	▶	GO TO 10.
NG (Drips)	▶	Replace the injectors from which fuel is dripping. Always replace O-ring with new one.

<b>10</b>	<b>CHECK INTERMITTENT INCIDENT</b>	
Refer to "TROUBLE DIAGNOSIS FOR INTERMITTENT INCIDENT", EC-115.		
▶		<b>INSPECTION END</b>

# DTC P0180 TANK FUEL TEMPERATURE SENSOR

Component Description

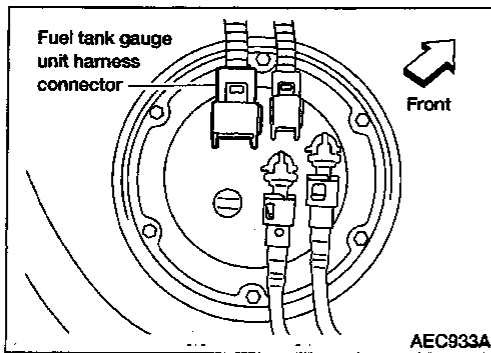

## Component Description

NEEC0106

The tank fuel temperature sensor is used to detect the fuel temperature inside the fuel tank. The sensor modifies a voltage signal from the ECM. The modified signal returns to the ECM as the fuel temperature input. The sensor uses a thermistor which is sensitive to the change in temperature. The electrical resistance of the thermistor decreases as temperature increases.

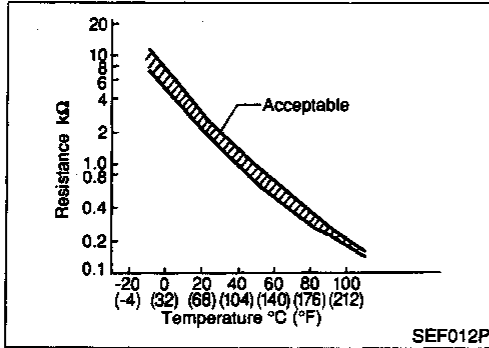

## <Reference data>

Fluid temperature · °C (°F)	Voltage* (V)	Resistance (kΩ)
20 (68)	3.5	2.3 - 2.7
50 (122)	2.2	0.79 - 0.90

\*: These data are reference values and are measured between ECM terminal 60 (Tank fuel temperature sensor) and ECM terminal 32 (ECM ground).

## On Board Diagnosis Logic

NEEC0167

DTC No.	Malfunction is detected when ...	Check Items (Possible Cause)
P0180 0402	<ul style="list-style-type: none"> <li>An excessively high or low voltage is sent to ECM.</li> <li>Rationally incorrect voltage is sent to ECM, compared with the voltage signals from engine coolant temperature sensor and intake air temperature sensor.</li> </ul>	<ul style="list-style-type: none"> <li>Harness or connectors (The sensor circuit is open or shorted.)</li> <li>Tank fuel temperature sensor</li> </ul>

## DTC Confirmation Procedure

NEEC0188

### NOTE:

If "DTC Confirmation Procedure" has been previously conducted, always turn ignition switch "OFF" and wait at least 5 seconds before conducting the next test.

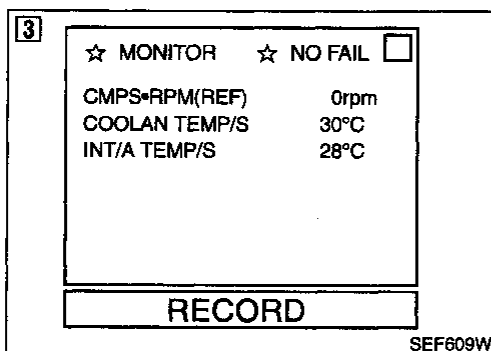

### With CONSULT

- Turn ignition switch "ON".
- Select "DATA MONITOR" mode with CONSULT.
- Wait at least 10 seconds.  
If the result is NG, go to "Diagnostic Procedure", EC-264.  
If the result is OK, go to following step.
- Check "COOLAN TEMP/S" value.  
If "COOLAN TEMP/S" is less than 60°C (140°F), the result will be OK.  
If "COOLAN TEMP/S" is above 60°C (140°F), go to the following step.

## DTC P0180 TANK FUEL TEMPERATURE SENSOR

DTC Confirmation Procedure (Cont'd)

- 5) Cool engine down until "COOLANT TEMP/S" is less than 60°C (140°F).
- 6) Wait at least 10 seconds.
- 7) If 1st trip DTC is detected, go to "Diagnostic Procedure", EC-264.

### With GST

- 1) Turn ignition switch "ON" and wait at least 10 seconds.
- 2) Select "MODE 7" with GST.  
If the result is NG, go to "Diagnostic Procedure", EC-264.  
If the result is OK, go to following step.
- 3) Select "MODE 1" with GST and check for the engine coolant temperature.  
If the temperature is less than 60°C (140°F), the result will be OK.  
If the temperature is above 60°C (140°F), go to the following step.
- 4) Cool engine down until the engine coolant temperature is less than 60°C (140°F).
- 5) Wait at least 10 seconds.
- 6) Select "MODE 7" with GST.
- 7) If 1st trip DTC is detected, go to "Diagnostic Procedure", EC-264.

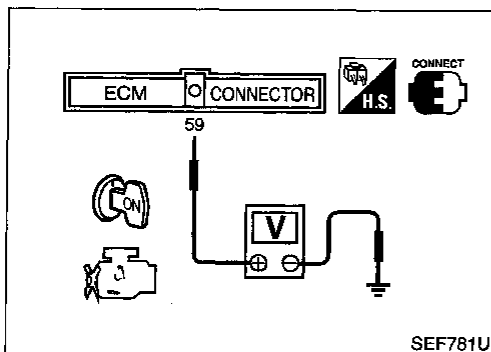

### No Tools

- 1) Turn ignition switch "ON" and wait at least 10 seconds.
- 2) Turn ignition switch "OFF", wait at least 5 seconds and then turn "ON".
- 3) Perform "Diagnostic Test Mode II (Self-diagnostic results)" with ECM.  
If the result is NG, go to "Diagnostic Procedure", EC-264.  
If the result is OK, go to following step.
- 4) Check voltage between ECM terminal 59 (Engine coolant temperature sensor signal) and ground.  
If the voltage is more than 1.9V, the result will be OK.  
If the voltage is less than 1.9V, go to the following step.
- 5) Cool engine down until the voltage becomes more than 1.9V.
- 6) Wait at least 10 seconds.
- 7) Turn ignition switch "OFF", wait at least 5 seconds and then turn "ON".
- 8) Perform "Diagnostic Test Mode II (Self-diagnostic results)" with ECM.
- 9) If 1st trip DTC is detected, go to "Diagnostic Procedure", EC-264.

# DTC P0180 TANK FUEL TEMPERATURE SENSOR

Wiring Diagram

## Wiring Diagram

NEEC0169

## EC-TFTS-01

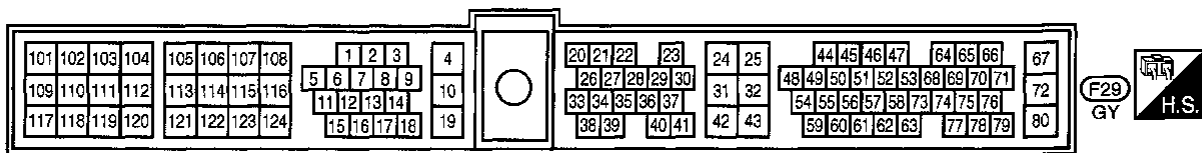
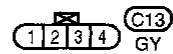
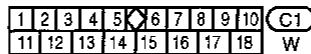
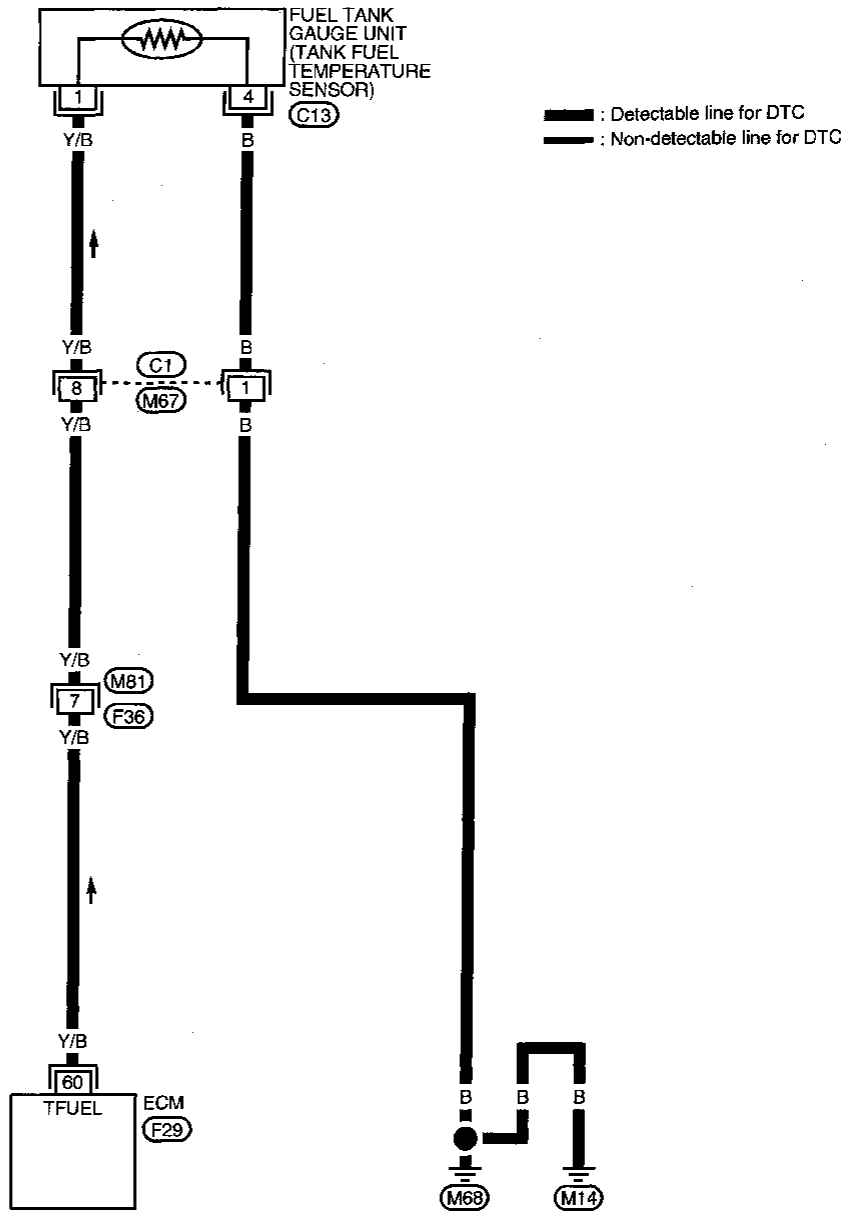

AEC758A

GI  
MA  
EM  
LC  
EC  
FE  
CL  
MT  
AT  
TF  
PD  
FA  
RA  
BR  
ST  
RS  
BT  
HA  
EL  
IDX

# DTC P0180 TANK FUEL TEMPERATURE SENSOR

Diagnostic Procedure

## Diagnostic Procedure

NEEC0170

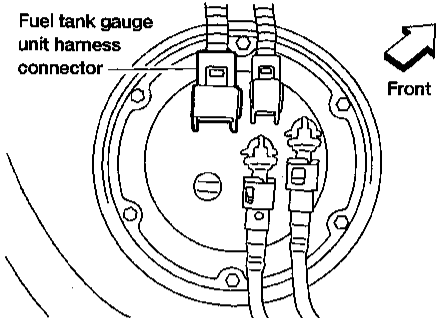
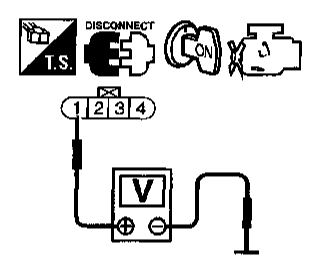
<b>1</b>	<b>CHECK POWER SUPPLY</b>						
<p>1. Turn ignition switch "OFF". 2. Disconnect fuel tank gauge unit harness connector.</p>  <p style="text-align: right;">Front</p> <p style="text-align: right;">AEC933A</p> <p>3. Turn ignition switch "ON". 4. Check voltage between terminal 1 and ground with CONSULT or tester.</p>  <p style="text-align: right;">SEF639W</p> <p style="text-align: center;"><b>Voltage: Approximately 5V</b></p> <p style="text-align: center;"><b>OK or NG</b></p> <table border="1" style="width: 100%;"> <tr> <td>OK</td> <td>▶</td> <td>GO TO 3.</td> </tr> <tr> <td>NG</td> <td>▶</td> <td>GO TO 2.</td> </tr> </table>		OK	▶	GO TO 3.	NG	▶	GO TO 2.
OK	▶	GO TO 3.					
NG	▶	GO TO 2.					

<b>2</b>	<b>DETECT MALFUNCTIONING PART</b>
<p>Check the following.</p> <ul style="list-style-type: none"> <li>• Harness connectors C1, M67</li> <li>• Harness connectors M81, F36</li> <li>• Harness for open or short between ECM and tank fuel temperature sensor</li> </ul> <p style="text-align: right;">▶ Repair harness or connector.</p>	

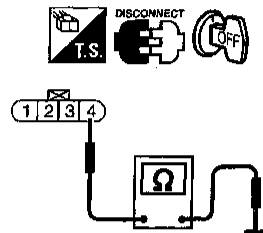
<b>3</b>	<b>CHECK GROUND CIRCUIT</b>						
<p>1. Turn ignition switch "OFF". 2. Check harness continuity between terminal 4 and body ground.</p>  <p style="text-align: right;">SEF640W</p> <p style="text-align: center;"><b>Continuity should exist.</b></p> <p>3. Also check harness for short to ground and short to power.</p> <p style="text-align: center;"><b>OK or NG</b></p> <table border="1" style="width: 100%;"> <tr> <td>OK</td> <td>▶</td> <td>GO TO 5.</td> </tr> <tr> <td>NG</td> <td>▶</td> <td>GO TO 4.</td> </tr> </table>		OK	▶	GO TO 5.	NG	▶	GO TO 4.
OK	▶	GO TO 5.					
NG	▶	GO TO 4.					

<b>4</b>	<b>DETECT MALFUNCTIONING PART</b>
<p>Check the following.</p> <ul style="list-style-type: none"> <li>• Harness connectors C1, M67</li> <li>• Harness for open or short between tank fuel temperature sensor and body ground</li> </ul> <p style="text-align: right;">▶ Repair open circuit or short to ground or short to power in harness or connectors.</p>	

<b>5</b>	<b>CHECK TANK FUEL TEMPERATURE SENSOR</b>						
<p>Refer to "Component Inspection", EC-265.</p> <p style="text-align: center;"><b>OK or NG</b></p> <table border="1" style="width: 100%;"> <tr> <td>OK</td> <td>▶</td> <td>GO TO 6.</td> </tr> <tr> <td>NG</td> <td>▶</td> <td>Replace tank fuel temperature sensor.</td> </tr> </table>		OK	▶	GO TO 6.	NG	▶	Replace tank fuel temperature sensor.
OK	▶	GO TO 6.					
NG	▶	Replace tank fuel temperature sensor.					

<b>6</b>	<b>CHECK INTERMITTENT INCIDENT</b>
<p>Refer to "TROUBLE DIAGNOSIS FOR INTERMITTENT INCIDENT", EC-115.</p> <p style="text-align: right;">▶ INSPECTION END</p>	

# DTC P0180 TANK FUEL TEMPERATURE SENSOR

Component Inspection

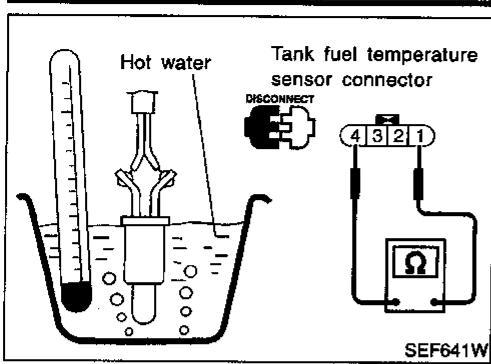

## Component Inspection

### TANK FUEL TEMPERATURE SENSOR

NEEC0171

GI

NEEC0171S01

Check resistance by heating with hot water or heat gun as shown in the figure.

MA

Temperature °C (°F)	Resistance kΩ
20 (68)	2.3 - 2.7
50 (122)	0.79 - 0.90

EM

If NG, replace tank fuel temperature sensor.

LC

**EC**

FE

CL

MT

AT

TF

PD

FA

RA

BR

ST

RS

BT

HA

EL

IDX

# DTC P0300 - P0306 NO. 6 - 1 CYLINDER MISFIRE, MULTIPLE CYLINDER MISFIRE

On Board Diagnosis Logic

## On Board Diagnosis Logic

NEEC0172

If a misfire occurs, the engine speed will fluctuate. If the fluctuation is detected by the crankshaft position sensor (OBD), the misfire is diagnosed.

Sensor	Input Signal to ECM	ECM function
Crankshaft position sensor (OBD)	Engine speed	On board diagnosis of misfire

The misfire detection logic consists of the following two conditions.

**1. One Trip Detection Logic (Three Way Catalyst Damage)**

When a misfire is detected which will overheat and damage the three way catalyst, the malfunction indicator lamp (MIL) will start blinking; even during the first trip. In this condition, ECM monitors the misfire every 200 revolutions.

If the misfire frequency decreases to a level that will not damage the three way catalyst, the MIL will change from blinking to lighting up.

(After the first trip detection, the MIL will light up from engine starting. If a misfire is detected that will cause three way catalyst damage, the MIL will start blinking.)

**2. Two Trip Detection Logic (Exhaust quality deterioration)**

When a misfire that will not damage the three way catalyst (but will affect exhaust emission) occurs, the malfunction indicator lamp will light up based on two trip detection logic. In this condition, ECM monitors the misfire for every 1,000 revolutions of the engine.

DTC No.	Malfunction is detected when ...	Check Items (Possible Cause)
P0300 (0701)	Multiple cylinders misfire.	<ul style="list-style-type: none"> <li>• Improper spark plug</li> <li>• Insufficient compression</li> <li>• Incorrect fuel pressure</li> <li>• EGR valve</li> <li>• The injector circuit is open or shorted</li> <li>• Injectors</li> <li>• Intake air leak</li> <li>• The ignition secondary circuit is open or shorted</li> <li>• Lack of fuel</li> <li>• Drive plate</li> <li>• Front heated oxygen sensor</li> <li>• Incorrect distributor rotor</li> </ul>
P0301 (0608)	• No. 1 cylinder misfires.	
P0302 (0607)	• No. 2 cylinder misfires.	
P0303 (0606)	• No. 3 cylinder misfires.	
P0304 (0605)	• No. 4 cylinder misfires.	
P0305 (0604)	• No. 5 cylinder misfires.	
P0306 (0603)	• No. 6 cylinder misfires.	

4

MONITOR     NO FAIL

CMPS•RPM(REF)	2000rpm
COOLAN TEMP/S	90°C
VHCL SPEED SE	50km/h
THRTL POS SEN	0.96V
CLSD THL/P SW	OFF
P/N POSI SW	OFF

RECORD

SEF869UA

### DTC Confirmation Procedure

NEEC0173

**CAUTION:**

**Always drive vehicle at a safe speed.**

**NOTE:**

If "DTC Confirmation Procedure" has been previously conducted, always turn ignition switch "OFF" and wait at least 5 seconds before conducting the next test.

④ **With CONSULT**

- 1) Turn ignition switch "ON", and select "DATA MONITOR" mode with CONSULT.
- 2) Start engine and warm it up to normal operating temperature.



# DTC P0300 - P0306 NO. 6 - 1 CYLINDER MISFIRE, MULTIPLE CYLINDER MISFIRE

DTC Confirmation Procedure (Cont'd)

- 3) Turn ignition switch "OFF" and wait at least 5 seconds.
- 4) Start engine again and drive at 1,500 to 3,000 rpm for at least 3 minutes.  
**Hold the accelerator pedal as steady as possible.**

**NOTE:**

**Refer to the freeze frame data for the test driving conditions.**

- 5) If 1st trip DTC is detected, go to "Diagnostic Procedure", EC-267.

**With GST**

- 1) Start engine and warm it up to normal operating temperature.
- 2) Turn ignition switch "OFF" and wait at least 5 seconds.
- 3) Start engine again and drive at 1,500 to 3,000 rpm for at least 3 minutes.  
**Hold the accelerator pedal as steady as possible.**

**NOTE:**

**Refer to the freeze frame data for the test driving conditions.**

- 4) Select "MODE 7" with GST.
- 5) If 1st trip DTC is detected, go to "Diagnostic Procedure", EC-267.

**No Tools**

- 1) Start engine and warm it up to normal operating temperature.
- 2) Turn ignition switch "OFF" and wait at least 5 seconds.
- 3) Start engine again and drive at 1,500 to 3,000 rpm for at least 3 minutes.  
**Hold the accelerator pedal as steady as possible.**

- 4) Turn ignition switch "OFF", wait at least 5 seconds, and then turn "ON".
- 5) Perform "Diagnostic Test Mode II (Self-diagnostic results)" with ECM.
- 6) If 1st trip DTC is detected, go to "Diagnostic Procedure", EC-267.

## Diagnostic Procedure

NEEC0174

<b>1</b>	<b>CHECK FOR INTAKE AIR LEAK</b>	
1. Start engine and run it at idle speed. 2. Listen for the sound of the intake air leak.		
OK or NG		
OK	▶	GO TO 2.
NG	▶	Discover air leak location and repair.

<b>3</b>	<b>CHECK EGR FUNCTION</b>	
Perform "DTC Confirmation Procedure" of "DTC P1402 EGR FUNCTION (OPEN)". Refer to EC-390.		
OK or NG		
OK	▶	GO TO 4.
NG	▶	Repair EGR system.

<b>2</b>	<b>CHECK FOR EXHAUST SYSTEM CLOGGING</b>	
Stop engine and visually check exhaust tube, three way catalyst and muffler for dents.		
OK or NG		
OK	▶	GO TO 3.
NG	▶	Repair or replace it.

GI  
MA  
EM  
LC  
EC  
FE  
CL  
MT  
AT  
TF  
PD  
FA  
RA  
BR  
ST  
RS  
BT  
HA  
EL  
IDX

# DTC P0300 - P0306 NO. 6 - 1 CYLINDER MISFIRE, MULTIPLE CYLINDER MISFIRE

Diagnostic Procedure (Cont'd)

## 4 PERFORM POWER BALANCE TEST

**With CONSULT**

1. Perform "POWER BALANCE" in "ACTIVE TEST" mode.

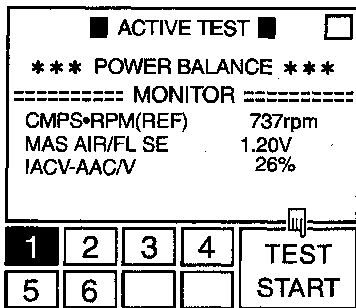

SEF389V

2. Is there any cylinder which does not produce a momentary engine speed drop?

**Without CONSULT**

When disconnecting each injector harness connector one at a time, is there any cylinder which does not produce a momentary engine speed drop?

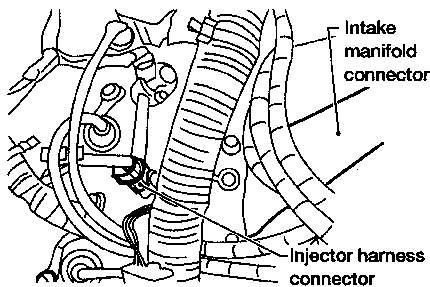

AEC646A

Yes or No

Yes	▶	GO TO 5.
No	▶	GO TO 8.

## 5 CHECK INJECTOR

Does each injector make an operating sound at idle?

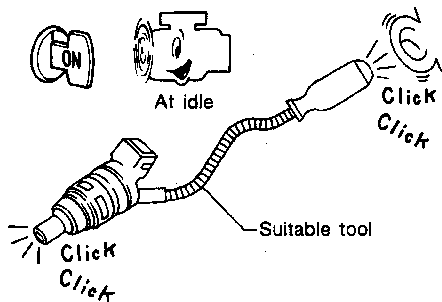

MEC703B

Yes or No

Yes	▶	GO TO 6.
No	▶	Check injector(s) and circuit(s). Refer to EC-460.

## 6 CHECK IGNITION SPARK

1. Disconnect ignition wire from spark plug.
2. Connect a known good spark plug to the ignition wire.
3. Place end of spark plug against a suitable ground and crank engine.
4. Check for spark.

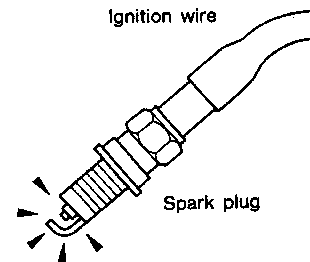

SEF282G

OK or NG

OK	▶	GO TO 8.
NG	▶	GO TO 7.

## 7 CHECK IGNITION WIRES

Refer to "Component Inspection", EC-270.

OK or NG

OK	▶	<b>Check the following:</b> <ul style="list-style-type: none"> <li>• Distributor rotor head for incorrect parts</li> <li>• Ignition coil, power transistor and their circuits</li> </ul> Refer to EC-366.
NG	▶	Replace.

## 8 CHECK SPARK PLUGS

Remove the spark plugs and check for fouling, etc.

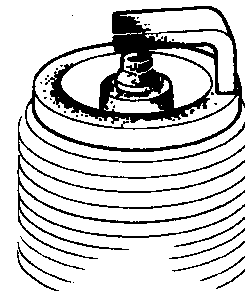

SEF156I

OK or NG

OK	▶	GO TO 9.
NG	▶	Repair or replace spark plug(s) with standard type one(s). For spark plug type, refer to "ENGINE MAINTENANCE" in MA section.

# DTC P0300 - P0306 NO. 6 - 1 CYLINDER MISFIRE, MULTIPLE CYLINDER MISFIRE

Diagnostic Procedure (Cont'd)

<b>9</b>	<b>CHECK COMPRESSION PRESSURE</b>
Refer to EM section. • Check compression pressure. <b>Standard:</b> 1,196 kPa(12.2 kg/cm <sup>2</sup> , 173 psi)/300 rpm <b>Minimum:</b> 883 kPa (9.0 kg/cm <sup>2</sup> , 128 psi)/300 rpm <b>Difference between each cylinder:</b> 98 kPa (1.0 kg/cm <sup>2</sup> , 14 psi)/300 rpm <p style="text-align: center;"><b>OK or NG</b></p>	
OK	▶ GO TO 10.
NG	▶ Check pistons, piston rings, valves, valve seats and cylinder head gaskets.

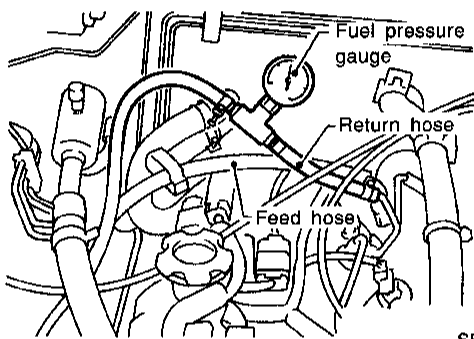
<b>10</b>	<b>CHECK FUEL PRESSURE</b>
1. Install any parts removed. 2. Release fuel pressure to zero. Refer to EC-31. 3. Install fuel pressure gauge and check fuel pressure.	
 <p style="text-align: right; font-size: small;">SEF964R</p>	
At idle: Approx. 235 kPa (2.4 kg/cm <sup>2</sup> , 34 psi) <p style="text-align: center;"><b>OK or NG</b></p>	
OK	▶ GO TO 12.
NG	▶ GO TO 11.

<b>11</b>	<b>DETECT MALFUNCTIONING PART</b>
Check the following. • Fuel pump and circuit (Refer to EC-467.) • Fuel pressure regulator (Refer to EC-32.) • Fuel lines (Refer to "ENGINE MAINTENANCE" in MA section.) • Fuel filter for clogging	
▶ Repair or replace.	

<b>12</b>	<b>CHECK IGNITION TIMING</b>
Perform "Basic Inspection", EC-86. <p style="text-align: center;"><b>OK or NG</b></p>	
OK	▶ GO TO 13.
NG	▶ Adjust ignition timing.

<b>13</b>	<b>CHECK FRONT HEATED OXYGEN SENSOR LH/RH</b>
Refer to "Component Inspection", EC-172. <p style="text-align: center;"><b>OK or NG</b></p>	
OK	▶ GO TO 14.
NG	▶ Replace front heated oxygen sensor.

<b>14</b>	<b>CHECK MASS AIR FLOW SENSOR</b>
(D) <b>With CONSULT</b> Check mass air flow sensor signal in "DATA MONITOR" mode with CONSULT. 3.3 - 4.8 g-m/sec: at idling 12.0 - 14.9 g-m/sec: at 2,500 rpm	
(S) <b>With GST</b> Check mass air flow sensor signal in MODE 1 with GST. 3.3 - 4.8 g-m/sec: at idling 12.0 - 14.9 g-m/sec: at 2,500 rpm	
(NO TOOL) <b>No Tools</b> Check voltage between ECM terminal 54 and ground. 1.0 - 1.7V: at idling 1.7 - 2.3V: at 2,500 rpm <p style="text-align: center;"><b>OK or NG</b></p>	
OK	▶ GO TO 15.
NG	▶ Check connectors for rusted terminals or loose connections in the mass air flow sensor circuit or engine grounds. Refer to EC-121.

<b>15</b>	<b>CHECK SYMPTOM MATRIX CHART</b>
Check items on the rough idle symptom in "Symptom Matrix Chart", EC-97. <p style="text-align: center;"><b>OK or NG</b></p>	
OK	▶ GO TO 16.
NG	▶ Repair or replace.

<b>16</b>	<b>ERASE THE 1ST TRIP DTC</b>
Some tests may cause a 1st trip DTC to be set. Erase the 1st trip DTC from the ECM memory after performing the tests. Refer to EC-55.	
▶ GO TO 17.	

<b>17</b>	<b>CHECK INTERMITTENT INCIDENT</b>
Refer to "TROUBLE DIAGNOSIS FOR INTERMITTENT INCIDENT", EC-115.	
▶ INSPECTION END	

GI  
MA  
EM  
LC  
EC  
FE  
CL  
MT  
AT  
TF  
PD  
FA  
RA  
BR  
ST  
RS  
BT  
HA  
EL  
IDX

# DTC P0300 - P0306 NO. 6 - 1 CYLINDER MISFIRE, MULTIPLE CYLINDER MISFIRE

## Component Inspection

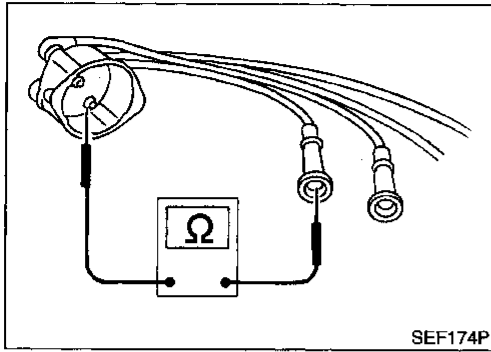

## Component Inspection

### IGNITION WIRES

NEEC0175

NEEC0175S01

1. Inspect wires for cracks, damage, burned terminals and for improper fit.
2. Measure the resistance of wires to their distributor cap terminal. Move each wire while testing to check for intermittent breaks.

### Resistance:

Cylinder No.	Resistance k $\Omega$ [at 25°C (77°F)]
1	Approximately 6.5
2	Approximately 10.0
3	Approximately 8.5
4	Approximately 12.5
5	Approximately 8.5
6	Approximately 11.0

If the resistance exceeds the above specification, inspect ignition wire to distributor cap connection. Clean connection or replace the ignition wire with a new one.

# DTC P0325 KNOCK SENSOR (KS)

Component Description

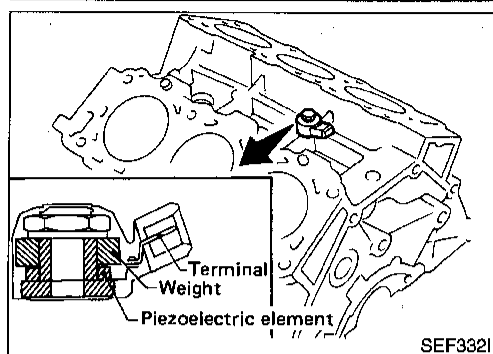

## Component Description

NEEC0176

The knock sensor is attached to the cylinder block. It senses engine knocking using a piezoelectric element. A knocking vibration from the cylinder block is sensed as vibrational pressure. This pressure is converted into a voltage signal and sent to the ECM. **Freeze frame data will not be stored in the ECM for the knock sensor. The MIL will not light for knock sensor malfunction. The knock sensor has one trip detection logic.**

## ECM Terminals and Reference Value

NEEC0177

Specification data are reference values and are measured between each terminal and 32 (ECM ground).

TERMI- NAL NO.	WIRE COLOR	ITEM	CONDITION	DATA (DC Voltage)
64	W	Knock sensor	[Engine is running] • Idle speed	Approximately 2.5V

## On Board Diagnosis Logic

NEEC0178

DTC No.	Malfunction is detected when ...	Check Items (Possible Cause)
P0325 0304	• An excessively low or high voltage from the knock sensor is sent to ECM.	• Harness or connectors (The knock sensor circuit is open or shorted.) • Knock sensor

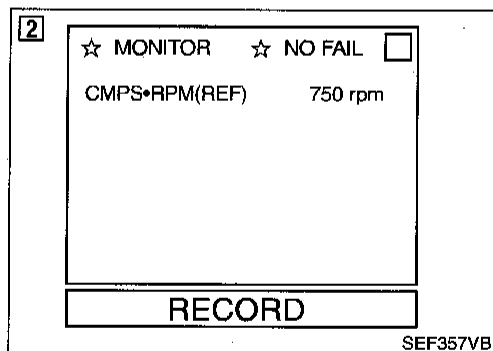

## DTC Confirmation Procedure

NEEC0179

### NOTE:

If "DTC Confirmation Procedure" has been previously conducted, always turn ignition switch "OFF" and wait at least 5 seconds before conducting the next test.

### TESTING CONDITION:

**Before performing the following procedure, confirm that battery voltage is more than 10V at idle.**

#### Ⓐ With CONSULT

- 1) Turn ignition switch "ON" and select "DATA MONITOR" mode with CONSULT.
- 2) Start engine and run it for at least 5 seconds at idle speed.
- 3) If DTC is detected, go to "Diagnostic Procedure", EC-274.

#### Ⓑ With GST

- 1) Start engine and run it for at least 5 seconds at idle speed.
- 2) Select "MODE 3" with GST.
- 3) If DTC is detected, go to "Diagnostic Procedure", EC-274.

#### Ⓒ No Tools

- 1) Start engine and run it for at least 5 seconds at idle speed.
- 2) Turn ignition switch "OFF", wait at least 5 seconds and then turn "ON".

## **DTC P0325 KNOCK SENSOR (KS)**

### *DTC Confirmation Procedure (Cont'd)*

---

- 3) Perform "Diagnostic Test Mode II" (Self-diagnostic results) with ECM.
- 4) If DTC is detected, go to "Diagnostic Procedure", EC-274.

# DTC P0325 KNOCK SENSOR (KS)

Wiring Diagram

## Wiring Diagram

NEECO180

EC-KS-01

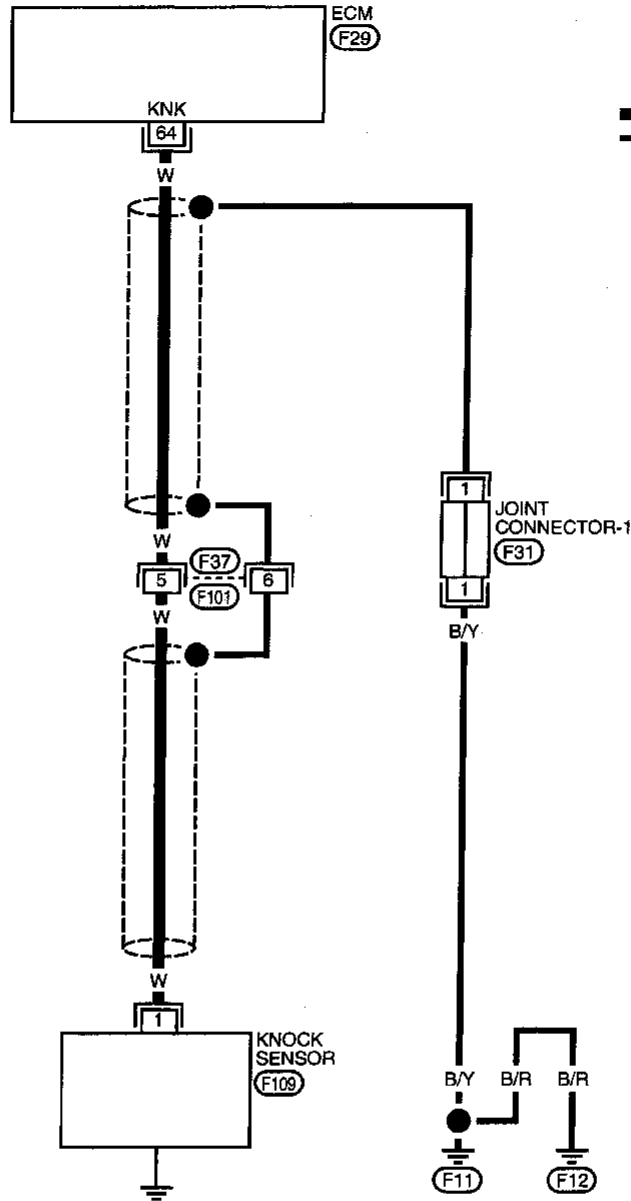

— : Detectable line for DTC  
 - - : Non-detectable line for DTC

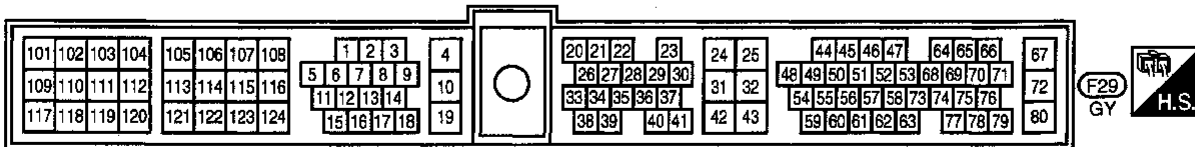
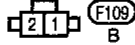

AEC739A

GI  
 MA  
 EM  
 LC  
**EC**  
 FE  
 CL  
 MT  
 AT  
 TF  
 PD  
 FA  
 RA  
 BR  
 ST  
 RS  
 BT  
 HA  
 EL  
 JD

# DTC P0325 KNOCK SENSOR (KS)

Diagnostic Procedure

## Diagnostic Procedure

NEEC0181

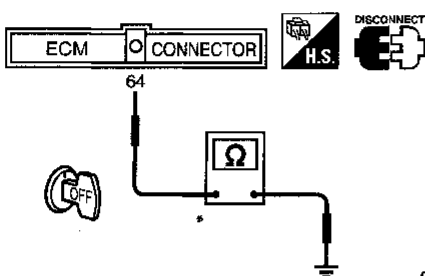
<b>1</b>	<b>CHECK INPUT SIGNAL CIRCUIT-I</b>						
<ol style="list-style-type: none"> <li>Turn ignition switch "OFF".</li> <li>Disconnect ECM harness connector.</li> <li>Check resistance between ECM terminal 64 and engine ground.</li> </ol> <p><b>NOTE:</b> It is necessary to use an ohmmeter which can measure more than 10 MΩ.</p>  <p style="text-align: right;">SEF704U</p> <p><b>Resistance:</b> Approximately 500 - 620 kΩ [at 25°C (77°F)]</p> <ol style="list-style-type: none"> <li>Also check harness for short to ground and short to power.</li> </ol> <p style="text-align: center;"><b>OK or NG</b></p> <table border="1" style="width: 100%;"> <tr> <td>OK</td> <td>▶</td> <td>GO TO 5.</td> </tr> <tr> <td>NG</td> <td>▶</td> <td>GO TO 2.</td> </tr> </table>		OK	▶	GO TO 5.	NG	▶	GO TO 2.
OK	▶	GO TO 5.					
NG	▶	GO TO 2.					

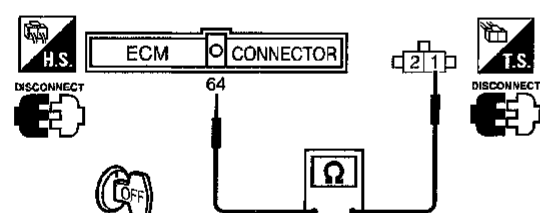
<b>2</b>	<b>CHECK INPUT SIGNAL CIRCUIT-II</b>						
<ol style="list-style-type: none"> <li>Disconnect knock sensor harness connector.</li> <li>Check harness continuity between ECM terminal 64 and terminal 1.</li> </ol>  <p style="text-align: right;">SEF642W</p> <p><b>Continuity should exist.</b></p> <ol style="list-style-type: none"> <li>Also check harness for short to ground and short to power.</li> </ol> <p style="text-align: center;"><b>OK or NG</b></p> <table border="1" style="width: 100%;"> <tr> <td>OK</td> <td>▶</td> <td>GO TO 4.</td> </tr> <tr> <td>NG</td> <td>▶</td> <td>GO TO 3.</td> </tr> </table>		OK	▶	GO TO 4.	NG	▶	GO TO 3.
OK	▶	GO TO 4.					
NG	▶	GO TO 3.					

<b>3</b>	<b>DETECT MALFUNCTIONING PART</b>		
<p>Check the following.</p> <ul style="list-style-type: none"> <li>Harness connector F37, F101</li> <li>Harness for open or short between ECM and knock sensor</li> </ul> <table border="1" style="width: 100%; margin-top: 10px;"> <tr> <td style="width: 20px;">▶</td> <td>Repair open circuit or short to ground or short to power in harness or connectors.</td> </tr> </table>		▶	Repair open circuit or short to ground or short to power in harness or connectors.
▶	Repair open circuit or short to ground or short to power in harness or connectors.		

<b>4</b>	<b>CHECK KNOCK SENSOR</b>	
Refer to "Component Inspection", EC-275.		
<b>OK or NG</b>		
OK	▶	GO TO 8.
NG	▶	Replace knock sensor.

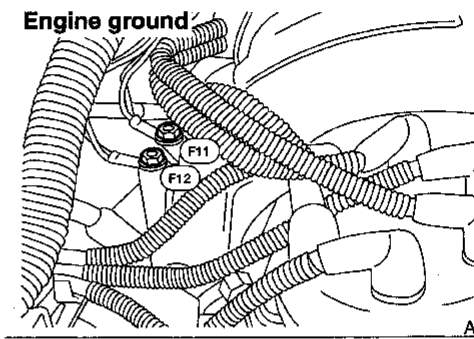
<b>5</b>	<b>RETIGHTEN GROUND SCREWS</b>
Loose and retighten engine ground screws.	
 <p style="text-align: right;">AEC640A</p>	
▶	
GO TO 6.	

<b>6</b>	<b>CHECK SHIELD CIRCUIT</b>						
<ol style="list-style-type: none"> <li>Disconnect harness connectors F37, F101.</li> <li>Check harness continuity between harness connector F37 and engine ground. <b>Continuity should exist.</b></li> <li>Also check harness for short to ground and short to power.</li> </ol> <p style="text-align: center;"><b>OK or NG</b></p> <table border="1" style="width: 100%;"> <tr> <td>OK</td> <td>▶</td> <td>GO TO 8.</td> </tr> <tr> <td>NG</td> <td>▶</td> <td>GO TO 7.</td> </tr> </table>		OK	▶	GO TO 8.	NG	▶	GO TO 7.
OK	▶	GO TO 8.					
NG	▶	GO TO 7.					

<b>7</b>	<b>DETECT MALFUNCTIONING PART</b>		
<p>Check the following.</p> <ul style="list-style-type: none"> <li>Harness connectors F37, F101</li> <li>Joint connectors - 1</li> <li>Harness for open or short between harness connector F37 and engine ground</li> </ul> <table border="1" style="width: 100%; margin-top: 10px;"> <tr> <td style="width: 20px;">▶</td> <td>Repair open circuit or short to ground or short to power in harness or connectors.</td> </tr> </table>		▶	Repair open circuit or short to ground or short to power in harness or connectors.
▶	Repair open circuit or short to ground or short to power in harness or connectors.		

<b>8</b>	<b>CHECK INTERMITTENT INCIDENT</b>
Refer to "TROUBLE DIAGNOSIS FOR INTERMITTENT INCIDENT", EC-115.	
▶	
<b>INSPECTION END</b>	



# DTC P0325 KNOCK SENSOR (KS)

Component Inspection

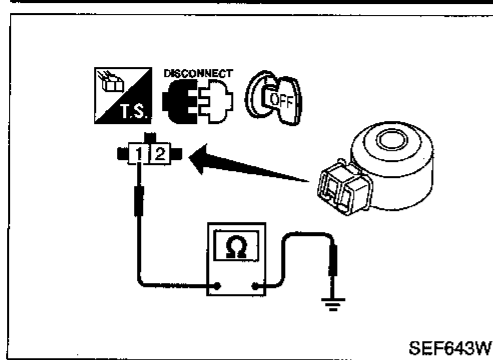

## Component Inspection

### KNOCK SENSOR

- Use an ohmmeter which can measure more than 10 M $\Omega$ .

1. Disconnect knock sensor harness connector.
2. Check resistance between terminal 2 and ground.

Resistance: 500 - 620 k $\Omega$  [at 25°C (77°F)]

#### CAUTION:

Do not use any knock sensors that have been dropped or physically damaged. Use only new ones.

NEEC0182

NEEC0182S01

GI

MA

EM

LC

**EC**

FE

CL

MT

AT

TF

PD

FA

RA

BR

ST

RS

BT

HA

EL

IDX

# DTC P0335 CRANKSHAFT POSITION SENSOR (CKPS) (OBD)

## Component Description

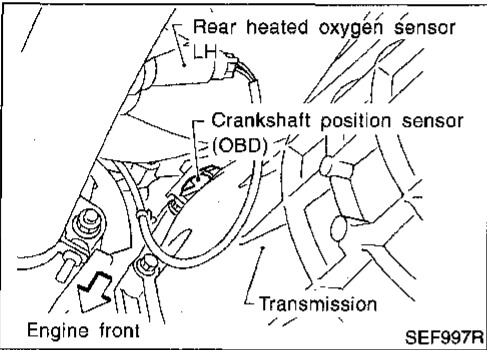
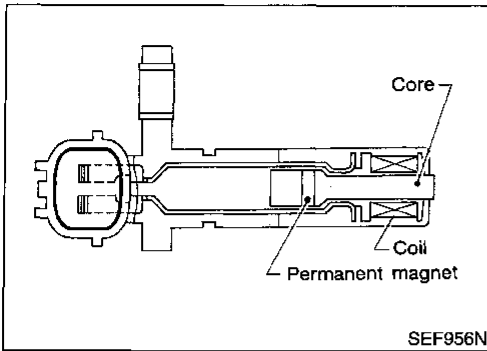

## Component Description

The crankshaft position sensor (OBD) is located on the transaxle housing facing the gear teeth (cogs) of the flywheel or drive plate. It detects the fluctuation of the engine revolution.

The sensor consists of a permanent magnet, core and coil.

When the engine is running, the high and low parts of the teeth cause the gap with the sensor to change.

The changing gap causes the magnetic field near the sensor to change.

Due to the changing magnetic field, the voltage from the sensor changes.

The ECM receives the voltage signal and detects the fluctuation of the engine revolution.

This sensor is not used to control the engine system. It is used only for the on board diagnosis.

## ECM Terminals and Reference Value

Specification data are reference values and are measured between each terminal and 32 (ECM ground).

TERMI- NAL NO.	WIRE COLOR	ITEM	CONDITION	DATA (AC Voltage)
47	L	Crankshaft position sensor (OBD)	<p>[Engine is running]</p> <ul style="list-style-type: none"> <li>• Warm-up condition</li> <li>• Idle speed</li> </ul>	<p>1 - 2V (AC range)</p> <p>SEF690W</p>
			<p>[Engine is running]</p> <ul style="list-style-type: none"> <li>• Engine speed is 2,000 rpm</li> </ul>	<p>3 - 4V (AC range)</p> <p>SEF691W</p>

## On Board Diagnosis Logic

DTC No.	Malfunction is detected when ...	Check Items (Possible Cause)
P0335 0802	<ul style="list-style-type: none"> <li>• The proper pulse signal from the crankshaft position sensor (OBD) is not sent to ECM while the engine is running at the specified engine speed.</li> </ul>	<ul style="list-style-type: none"> <li>• Harness or connectors (The crankshaft position sensor (OBD) circuit is open.)</li> <li>• Crankshaft position sensor (OBD)</li> </ul>

# DTC P0335 CRANKSHAFT POSITION SENSOR (CKPS) (OBD)

DTC Confirmation Procedure

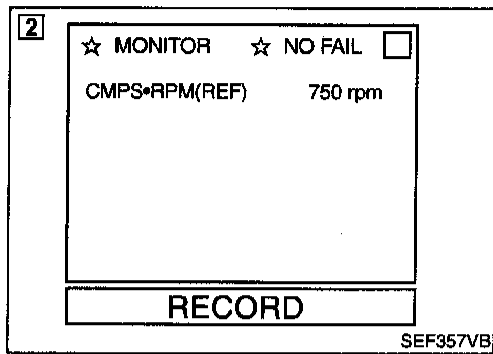

## DTC Confirmation Procedure

NEEC0186

### NOTE:

If "DTC Confirmation Procedure" has been previously conducted, always turn ignition switch "OFF" and wait at least 5 seconds before conducting the next test.

#### ④ With CONSULT

- 1) Turn ignition switch "ON" and select "DATA MONITOR" mode with CONSULT.
- 2) Start engine and run it for at least 15 seconds at idle speed.
- 3) If 1st trip DTC is detected, go to "Diagnostic Procedure", EC-279.

#### ④ With GST

- 1) Start engine and run it for at least 15 seconds at idle speed.
- 2) Select "MODE 7" with GST.
- 3) If 1st trip DTC is detected, go to "Diagnostic Procedure", EC-279.

#### ④ No Tools

- 1) Start engine and run it for at least 15 seconds at idle speed.
- 2) Turn ignition switch "OFF", wait at least 5 seconds and then turn "ON".
- 3) Perform "Diagnostic Test Mode II" (Self-diagnostic results) with ECM.
- 4) If 1st trip DTC is detected, go to "Diagnostic Procedure", EC-279.

GI

MA

EM

LC

EC

FE

CL

MT

AT

TF

PD

FA

RA

BR

ST

RS

BT

HA

EL

IDX

# DTC P0335 CRANKSHAFT POSITION SENSOR (CKPS) (OBD)

Wiring Diagram

## Wiring Diagram

NEEC0187

### EC-CKPS-01

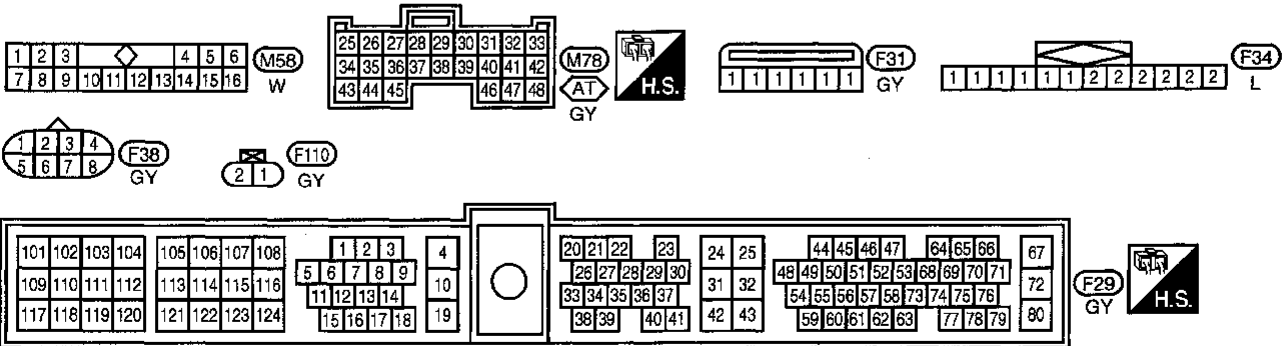
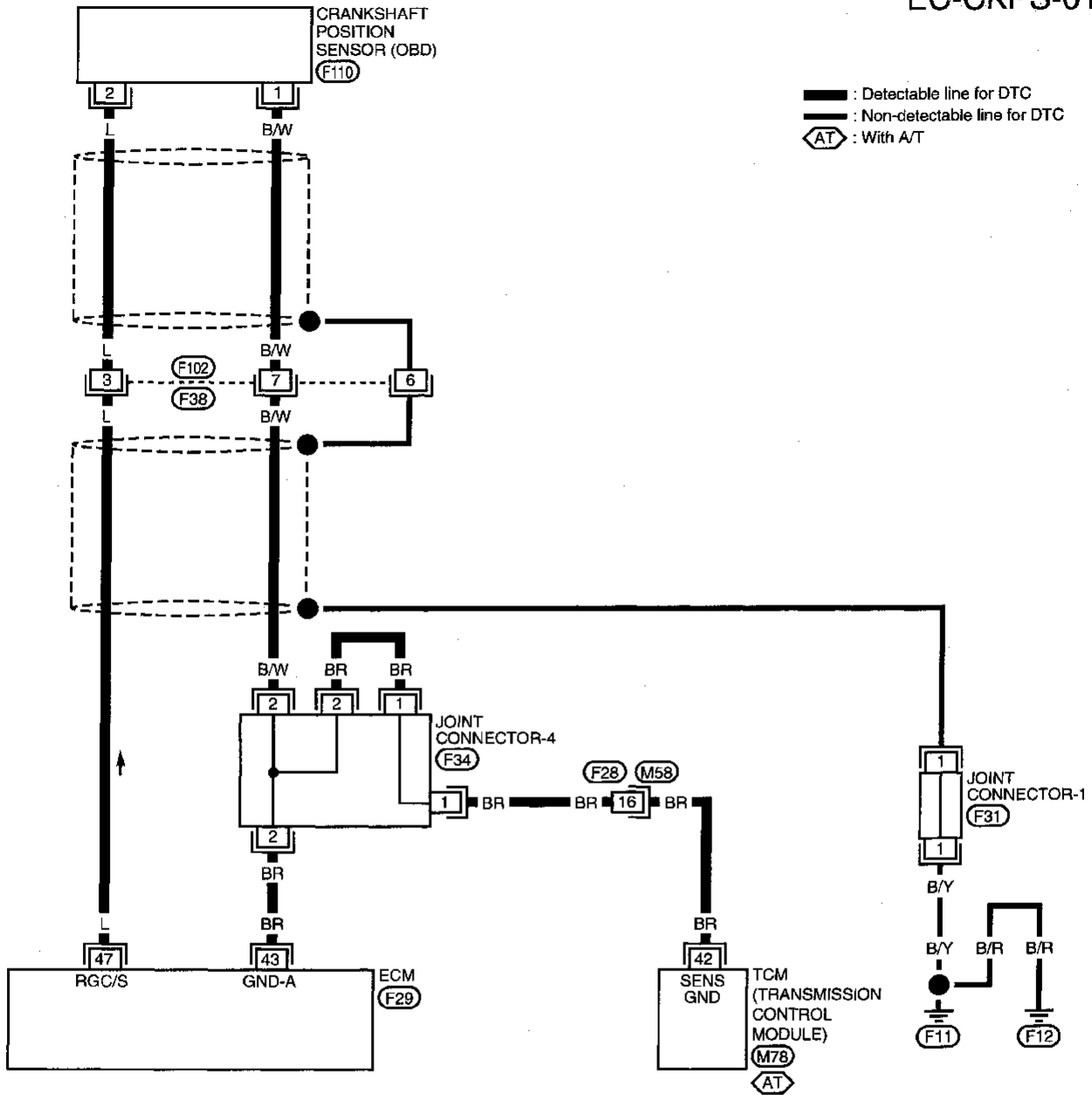

AEC740A

# DTC P0335 CRANKSHAFT POSITION SENSOR (CKPS) (OBD)

Diagnostic Procedure

## Diagnostic Procedure

NEEC0188

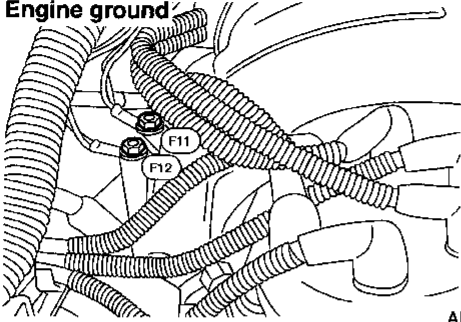
<b>1</b>	<b>RETIGHTEN GROUND SCREWS</b>
<ol style="list-style-type: none"> <li>Turn ignition switch "OFF".</li> <li>Loosen and retighten engine ground screws.</li> </ol>	
<p><b>Engine ground</b></p>  <p style="text-align: right;">AEC640A</p>	
▶ GO TO 2.	

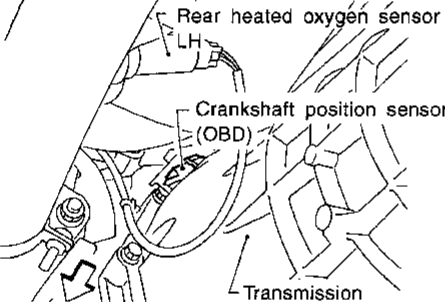
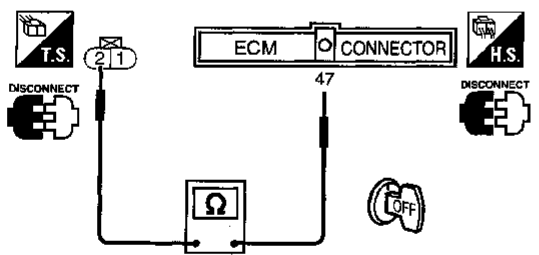
<b>2</b>	<b>CHECK INPUT SIGNAL CIRCUIT</b>
<ol style="list-style-type: none"> <li>Disconnect crankshaft position sensor (OBD) and ECM harness connectors.</li> </ol>	
 <p style="text-align: right;">SEF997R</p>	
<ol style="list-style-type: none"> <li>Check continuity between ECM terminal 47 and terminal 2.</li> </ol>	
 <p style="text-align: right;">SEF644W</p>	
<p><b>Continuity should exist.</b></p> <ol style="list-style-type: none"> <li>Also check harness for short to ground and short to power.</li> </ol> <p style="text-align: center;"><b>OK or NG</b></p>	
OK	▶ GO TO 4.
NG	▶ GO TO 3.

<b>3</b>	<b>DETECT MALFUNCTIONING PART</b>
<p>Check the following.</p> <ul style="list-style-type: none"> <li>Harness connectors F38, F102</li> <li>Harness for open or short between ECM and crankshaft position sensor (OBD)</li> </ul>	
▶ Repair open circuit or short to ground or short to power in harness or connectors.	

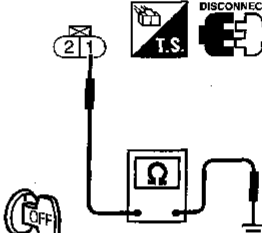
<b>4</b>	<b>CHECK GROUND CIRCUIT</b>
<ol style="list-style-type: none"> <li>Reconnect ECM harness connector.</li> <li>Check harness continuity between terminal 1 and engine ground.</li> </ol>	
 <p style="text-align: right;">SEF645W</p>	
<p><b>Continuity should exist.</b></p> <ol style="list-style-type: none"> <li>Also check harness for short to ground and short to power.</li> </ol> <p style="text-align: center;"><b>OK or NG</b></p>	
OK	▶ GO TO 6.
NG	▶ GO TO 5.

<b>5</b>	<b>DETECT MALFUNCTIONING PART</b>
<p>Check the following.</p> <ul style="list-style-type: none"> <li>Harness connectors F38, F102</li> <li>Harness connectors F28, M58</li> <li>Joint connector-4</li> <li>Harness for open or short between crankshaft position sensor (OBD) and ECM</li> <li>Harness for open or short between crankshaft position sensor (OBD) and TCM (Transmission Control Module)</li> </ul>	
▶ Repair open circuit or short to ground or short to power in harness or connectors.	

<b>6</b>	<b>CHECK CRANKSHAFT POSITION SENSOR (OBD)</b>
<p>Refer to "Component Inspection", EC-280.</p> <p style="text-align: center;"><b>OK or NG</b></p>	
OK	▶ GO TO 7.
NG	▶ Replace crankshaft position sensor (OBD).

GI  
MA  
EM  
LC  
EC  
FE  
CL  
MT  
AT  
TF  
PD  
FA  
RA  
BR  
ST  
RS  
BT  
HA  
EL  
IDX

# DTC P0335 CRANKSHAFT POSITION SENSOR (CKPS) (OBD)

Diagnostic Procedure (Cont'd)

<b>7</b>	<b>CHECK SHIELD CIRCUIT</b>
1. Disconnect harness connectors F38, F102. 2. Check harness continuity between harness connector F38 and engine ground. <b>Continuity should exist.</b> 3. Also check harness for short to ground and short to power. <b>OK or NG</b>	
OK	▶ GO TO 9.
NG	▶ GO TO 8.

<b>8</b>	<b>DETECT MALFUNCTIONING PART</b>
Check the following. <ul style="list-style-type: none"> <li>• Harness connectors F38, F102</li> <li>• Joint connector-1</li> <li>• Harness for open or short between harness connector F38 and engine ground</li> </ul>	
	▶ Repair open circuit or short to ground or short to power in harness or connectors.

<b>9</b>	<b>CHECK INTERMITTENT INCIDENT</b>
Refer to "TROUBLE DIAGNOSIS FOR INTERMITTENT INCIDENT", EC-115.	
	▶ <b>INSPECTION END</b>

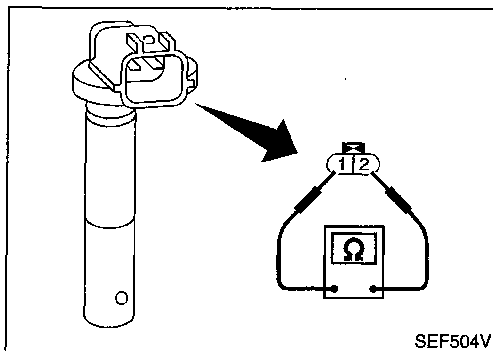
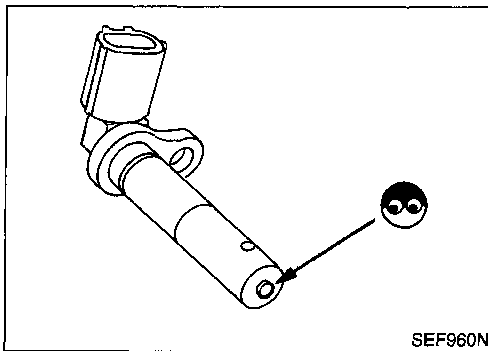

## Component Inspection

### CRANKSHAFT POSITION SENSOR (OBD)

NEEC0189

NEEC0189S01

1. Disconnect crankshaft position sensor (OBD) harness connector.
2. Loosen the fixing bolt of the sensor.
3. Remove the sensor.
4. Visually check the sensor for chipping.
5. Check resistance as shown in the figure.  
**Resistance: Approximately 166.5 - 203.5Ω [at 20°C (68°F)]**  
 If NG, replace crankshaft position sensor (OBD).

# DTC P0340 CAMSHAFT POSITION SENSOR (CMPS)

Component Description

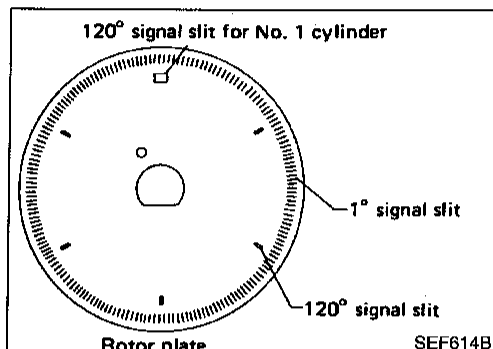
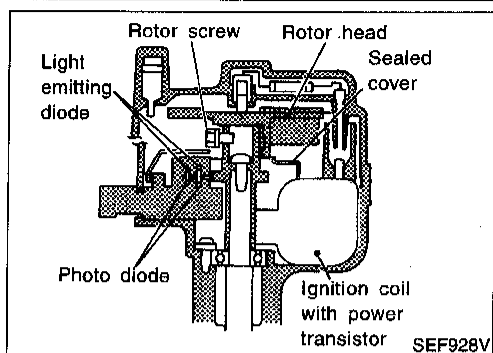

## Component Description

NEEC0190

The camshaft position sensor is a basic component of the engine control system. It monitors engine speed and piston position. These input signals to the ECM are used to control fuel injection, ignition timing and other functions.

The camshaft position sensor has a rotor plate and a wave-forming circuit. The rotor plate has 360 slits for a 1° (POS) signal and 6 slits for a 120° (REF) signal. The wave-forming circuit consists of Light Emitting Diodes (LED) and photo diodes.

The rotor plate is positioned between the LED and the photo diode. The LED transmits light to the photo diode. As the rotor plate turns, the slits cut the light to generate rough-shaped pulses. These pulses are converted into on-off signals by the wave-forming circuit and sent to the ECM.

The distributor is not repairable and must be replaced as an assembly except distributor cap and rotor head.

### NOTE:

The rotor screw which secures the distributor rotor head to the distributor shaft must be torqued properly.

: 3.6±0.3 N·m (37±3 kg·cm, 32±3 in·lb)

## ECM Terminals and Reference Value

NEEC0191

Specification data are reference values and are measured between each terminal and 32 (ECM ground).

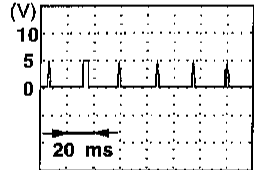
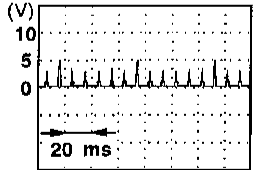
TER-MINAL NO.	WIRE COLOR	ITEM	CONDITION	DATA (DC Voltage)
4	OR/B	ECM relay (Self shut-off)	[Engine is running] [Ignition switch "OFF"] • For a few seconds after turning ignition switch "OFF"	0 - 1.5V
			[Ignition switch "OFF"] • A few seconds passed after turning ignition switch "OFF"	BATTERY VOLTAGE (11 - 14V)
44	PU	Camshaft position sensor (Reference signal)	[Engine is running] • Idle speed	0.3 - 0.5V 
48	PU		[Engine is running] • Engine speed is 2,000 rpm	0.3 - 0.5V 

## DTC P0340 CAMSHAFT POSITION SENSOR (CMPS)

ECM Terminals and Reference Value (Cont'd)

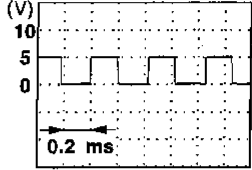
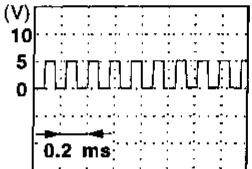
TER-MINAL NO.	WIRE COLOR	ITEM	CONDITION	DATA (DC Voltage)
49	LG	Camshaft position sensor (Position signal)	<b>[Engine is running]</b> <ul style="list-style-type: none"> <li>• Warm-up condition</li> <li>• Idle speed</li> </ul>	Approximately 2.5V 
			<b>[Engine is running]</b> <ul style="list-style-type: none"> <li>• Engine speed is 2,000 rpm</li> </ul>	Approximately 2.5V 
67	B/P	Power supply for ECM	<b>[Ignition switch "ON"]</b>	BATTERY VOLTAGE (11 - 14V)
72	B/P			
117	B/P	Current return	<b>[Engine is running]</b> <ul style="list-style-type: none"> <li>• Idle speed</li> </ul>	BATTERY VOLTAGE (11 - 14V)

### On Board Diagnosis Logic

NEEC0192

DTC No.	Malfunction is detected when ...	Check Items (Possible Cause)
P0340 0101	A)	Either 1° or 120° signal is not sent to ECM for the first few seconds during engine cranking.
	B)	Either 1° or 120° signal is not sent to ECM often enough while the engine speed is higher than the specified engine speed.
	C)	The relation between 1° and 120° signal is not in the normal range during the specified engine speed.
		<ul style="list-style-type: none"> <li>• Harness or connectors (The camshaft position sensor circuit is open or shorted.)</li> <li>• Camshaft position sensor</li> <li>• Starter motor (Refer to EL section.)</li> <li>• Starting system circuit (Refer to EL section.)</li> <li>• Dead (Weak) battery</li> </ul>

### DTC Confirmation Procedure

NEEC0193

**NOTE:**

- Perform "PROCEDURE FOR MALFUNCTION A" first. If DTC cannot be confirmed, perform "PROCEDURE FOR MALFUNCTION B AND C".
- If "DTC Confirmation Procedure" has been previously conducted, always turn ignition switch "OFF" and wait at least 5 seconds before conducting the next test.

**TESTING CONDITION:**

Before performing the following procedure, confirm that battery voltage is more than 10.5V at idle.



# DTC P0340 CAMSHAFT POSITION SENSOR (CMPS)

DTC Confirmation Procedure (Cont'd)

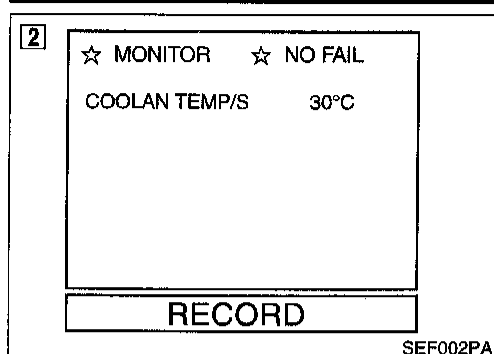

## PROCEDURE FOR MALFUNCTION A

NEEC0193501

### With CONSULT

- 1) Turn ignition switch "ON".
- 2) Select "DATA MONITOR" mode with CONSULT.
- 3) Crank engine for at least 2 seconds.
- 4) If 1st trip DTC is detected, go to "Diagnostic Procedure", EC-285.

### With GST

- 1) Crank engine for at least 2 seconds.
- 2) Select "MODE 7" with GST.
- 3) If 1st trip DTC is detected, go to "Diagnostic Procedure", EC-285.

### No Tools

- 1) Crank engine for at least 2 seconds.
- 2) Turn ignition switch "OFF", wait at least 5 seconds and then turn "ON".
- 3) Perform "Diagnostic Test Mode II" (Self-diagnostic results) with ECM.
- 4) If 1st trip DTC is detected, go to "Diagnostic Procedure", EC-285.

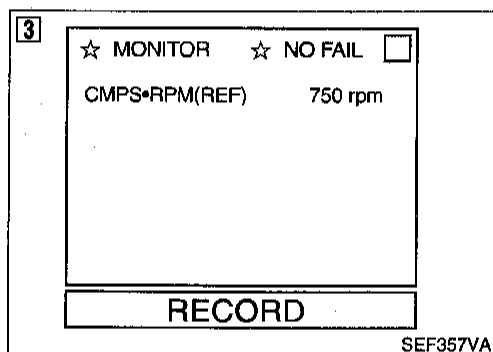

## PROCEDURE FOR MALFUNCTION B AND C

NEEC0193502

### With CONSULT

- 1) Turn ignition switch "ON".
- 2) Select "DATA MONITOR" mode with CONSULT.
- 3) Start engine and run it for at least 2 seconds at idle speed.
- 4) If 1st trip DTC is detected, go to "Diagnostic Procedure", EC-285.

### With GST

- 1) Start engine and run it for at least 2 seconds at idle speed.
- 2) Select "MODE 7" with GST.
- 3) If 1st trip DTC is detected, go to "Diagnostic Procedure", EC-285.

### No Tools

- 1) Start engine and run it for at least 2 seconds at idle speed.
- 2) Turn ignition switch "OFF", wait at least 5 seconds and then turn "ON".
- 3) Perform "Diagnostic Test Mode II" (Self-diagnostic results) with ECM.
- 4) If 1st trip DTC is detected, go to "Diagnostic Procedure", EC-285.

# DTC P0340 CAMSHAFT POSITION SENSOR (CMPS)

Wiring Diagram

## Wiring Diagram

NEEC0194

EC-CMPS-01

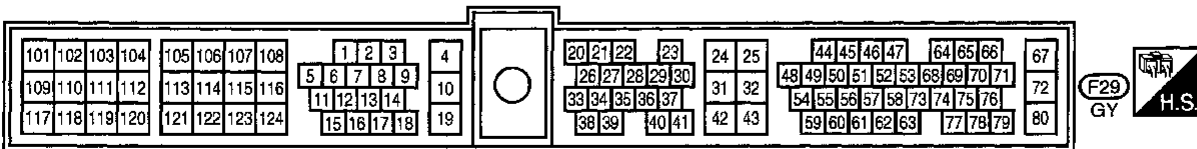
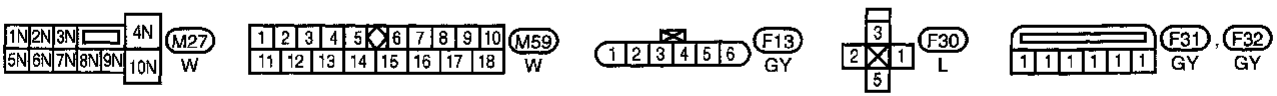
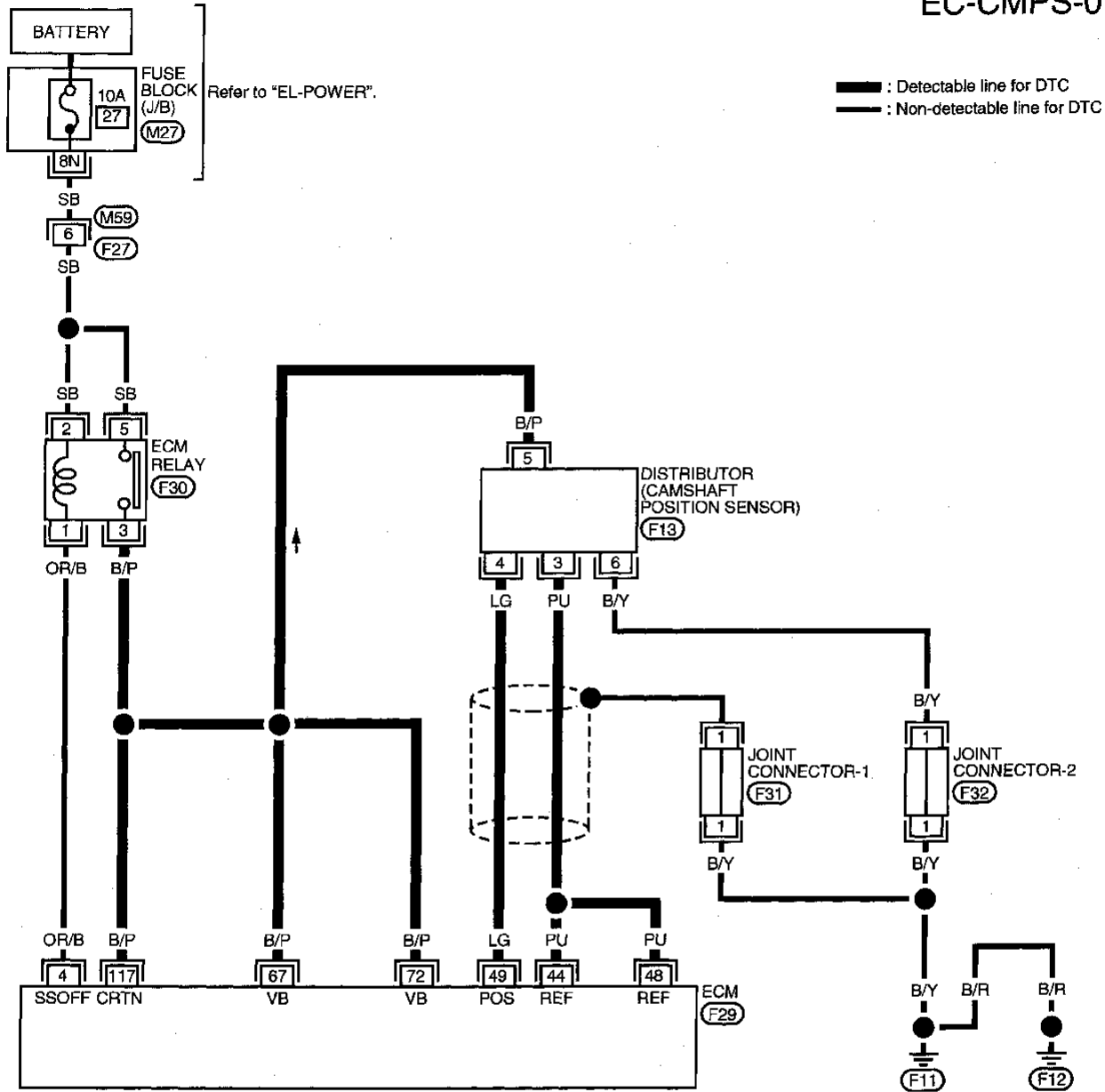

AEC741A

# DTC P0340 CAMSHAFT POSITION SENSOR (CMPS)

Diagnostic Procedure

## Diagnostic Procedure

NEEC0195

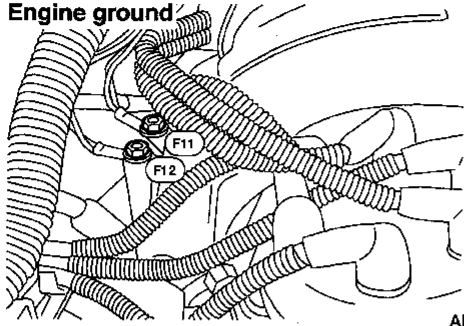
<b>1</b>	<b>RETIGHTEN GROUND SCREWS</b>
<ol style="list-style-type: none"> <li>Turn ignition switch "OFF".</li> <li>Loosen and retighten engine ground screws.</li> </ol>	
<p><b>Engine ground</b></p>  <p style="text-align: right;">AEC640A</p>	
▶ GO TO 2.	

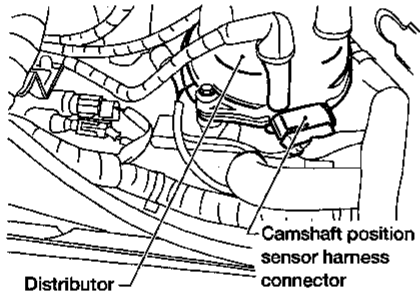
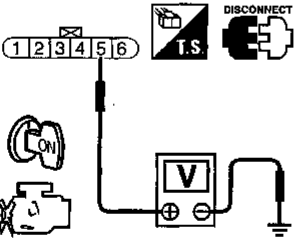
<b>2</b>	<b>CHECK POWER SUPPLY</b>
<ol style="list-style-type: none"> <li>Disconnect camshaft position sensor harness connector.</li> </ol>	
 <p style="text-align: right;">AEC647A</p>	
<ol style="list-style-type: none"> <li>Turn ignition switch "ON".</li> <li>Check voltage between terminal 5 and ground with CONSULT or tester.</li> </ol>	
 <p style="text-align: right;">SEF708U</p> <p><b>Voltage: Battery voltage</b></p> <p style="text-align: center;"><b>OK or NG</b></p>	
OK	▶ GO TO 4.
NG	▶ GO TO 3.

<b>3</b>	<b>DETECT MALFUNCTIONING PART</b>
<p>Check the following.</p> <ul style="list-style-type: none"> <li>Harness for open or short between camshaft position sensor and ECM relay</li> <li>Harness for open or short between camshaft position sensor and ECM</li> </ul>	
▶ Repair harness or connectors.	

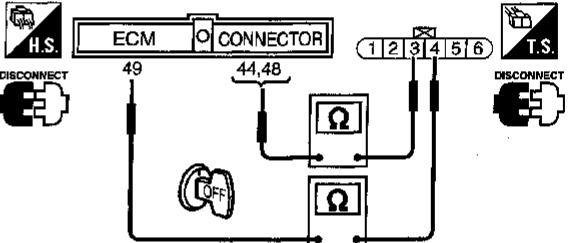
<b>4</b>	<b>CHECK INPUT SIGNAL CIRCUIT</b>
<ol style="list-style-type: none"> <li>Turn ignition switch "OFF".</li> <li>Disconnect ECM harness connector.</li> <li>Check harness continuity between sensor terminal 4 and ECM terminal 49, sensor terminal 3 and ECM terminals 44, 48.</li> </ol>	
 <p style="text-align: right;">SEF709U</p> <p style="text-align: center;"><b>Continuity should exist.</b></p>	
<ol style="list-style-type: none"> <li>Also check harness for short to ground and short to power.</li> </ol> <p style="text-align: center;"><b>OK or NG</b></p>	
OK	▶ GO TO 5.
NG	▶ Repair open circuit or short to ground or short to power in harness or connectors.

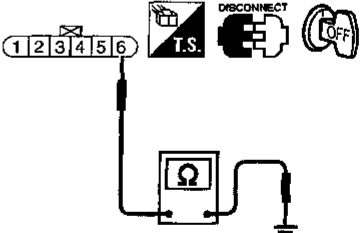
<b>5</b>	<b>CHECK GROUND CIRCUIT</b>
<ol style="list-style-type: none"> <li>Turn ignition switch "OFF".</li> <li>Check harness continuity between sensor terminal 6 and engine ground.</li> </ol>	
 <p style="text-align: right;">SEF710U</p> <p style="text-align: center;"><b>Continuity should exist.</b></p>	
<ol style="list-style-type: none"> <li>Also check harness for short to ground and short to power.</li> </ol> <p style="text-align: center;"><b>OK or NG</b></p>	
OK	▶ GO TO 7.
NG	▶ GO TO 6.

GI  
MA  
EM  
LC  
EC  
FE  
CL  
MT  
AT  
TF  
PD  
FA  
RA  
BR  
ST  
RS  
BT  
HA  
EL  
IDX

# DTC P0340 CAMSHAFT POSITION SENSOR (CMPS)

Diagnostic Procedure (Cont'd)

<b>6</b>	<b>DETECT MALFUNCTIONING PART</b>
Check the following. <ul style="list-style-type: none"> <li>• Joint connector-2</li> <li>• Harness for open or short between camshaft position sensor and engine ground</li> </ul>	
▶	Repair open circuit or short to ground or short to power in harness or connector.

<b>7</b>	<b>CHECK CAMSHAFT POSITION SENSOR</b>
Refer to "Component Inspection", EC-286.	
<b>OK or NG</b>	
OK	▶ GO TO 8.
NG	▶ Replace camshaft position sensor.

<b>8</b>	<b>CHECK SHIELD CIRCUIT</b>
1. Turn ignition switch "OFF". 2. Disconnect joint connector-1. 3. Check the following. <ul style="list-style-type: none"> <li>• Continuity between joint connector terminal and ground</li> <li>• Joint connector (Refer to "HARNESS LAYOUT" in EL section.)</li> </ul> <b>Continuity should exist.</b>	
4. Also check harness for short to ground and short to power.	
5. Then reconnect joint connector-1.	
<b>OK or NG</b>	
OK	▶ GO TO 9.
NG	▶ Repair open circuit or short to ground or short to power in harness or connectors.

<b>9</b>	<b>CHECK INTERMITTENT INCIDENT</b>
Refer to "TROUBLE DIAGNOSIS FOR INTERMITTENT INCIDENT", EC-115.	
▶ <b>INSPECTION END</b>	

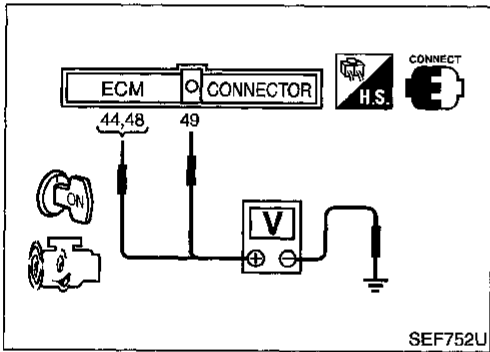

## Component Inspection CAMSHAFT POSITION SENSOR

NEEC0196

NEEC0196S01

1. Install any parts removed.
2. Start engine.
3. Check voltage between ECM terminals 44, 48 and ground, ECM terminal 49 and ground with DC range.

# DTC P0340 CAMSHAFT POSITION SENSOR (CMPS)

Component Inspection (Cont'd)

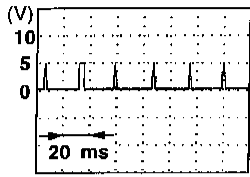
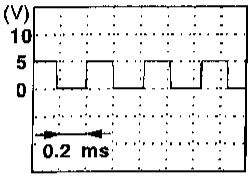
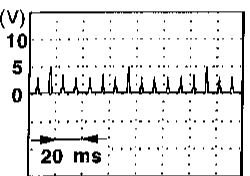
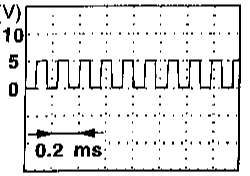
Condition	ECM terminal	Voltage
Engine running at idle	44, 48 and ground	<p>0.3 - 0.5V</p>  <p>SEF997U</p>
	49 and ground	<p>Approximately 2.5V</p>  <p>SEF999U</p>
Engine speed is 2,000 rpm	44, 48 and ground	<p>0.3 - 0.5V</p>  <p>SEF998U</p>
	49 and ground	<p>Approximately 2.5V</p>  <p>SEF001V</p>

If NG, replace distributor assembly with camshaft position sensor.

GI  
MA  
EM  
LC  
EC  
FE  
CL  
MT  
AT  
TF  
PD  
FA  
RA  
BR  
ST  
RS  
BT  
HA  
EL  
IDX

# DTC P0400 EGR FUNCTION (CLOSE)

Description

## Description SYSTEM DESCRIPTION

NEEC0197

NEEC0197S01

Sensor	Input Signal to ECM	ECM function	Actuator
Camshaft position sensor	Engine speed	EGR control	EGRC-solenoid valve
Mass air flow sensor	Amount of intake air		
Engine coolant temperature sensor	Engine coolant temperature		
Ignition switch	Start signal		
Throttle position sensor	Throttle position		

This system cuts and controls vacuum applied to the EGR valve to suit engine operating conditions. This cut-and-control operation is accomplished through the ECM and the EGRC-solenoid valve. When the ECM detects any of the following conditions, current does not flow through the solenoid valve. This causes the intake manifold vacuum to be discharged into the atmosphere. The EGR valve remains closed.

- Low engine coolant temperature
- Engine starting
- High-speed engine operation
- Engine idling
- Excessively high engine coolant temperature
- Mass air flow sensor malfunction

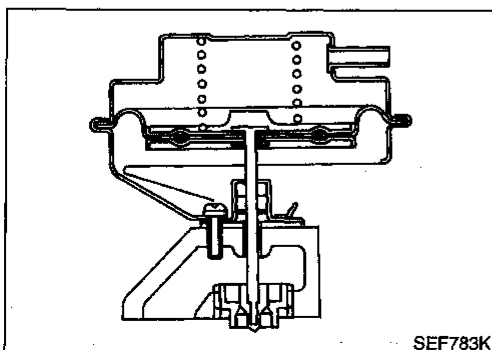
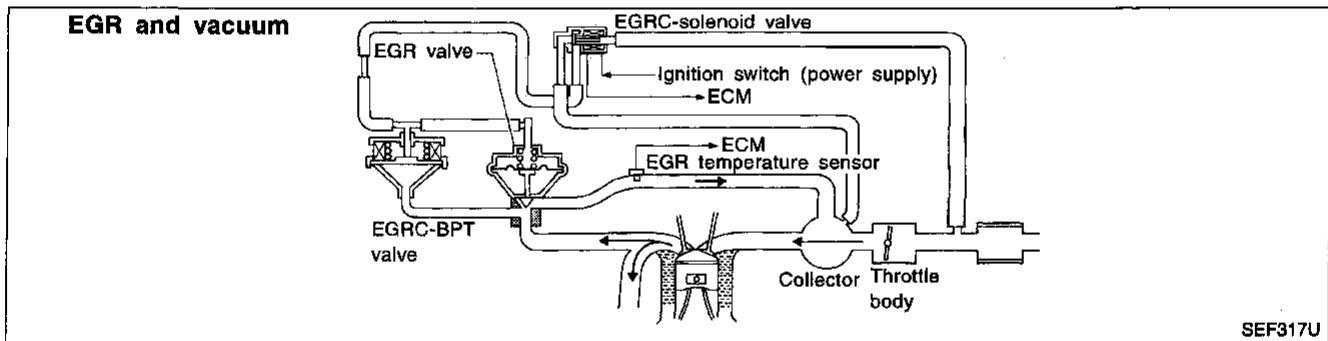

### COMPONENT DESCRIPTION

#### Exhaust Gas Recirculation (EGR) Valve

NEEC0197S02

NEEC0197S0201

The EGR valve controls the amount of exhaust gas routed to the intake manifold. Vacuum is applied to the EGR valve in response to throttle valve opening and EGRC-BPT valve operation. The vacuum controls the movement of a taper valve connected to the vacuum diaphragm in the EGR valve.

# DTC P0400 EGR FUNCTION (CLOSE)

Description (Cont'd)

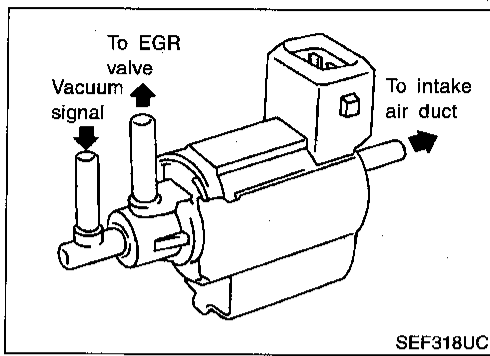

## EGRC-solenoid Valve

NEEC0197S0202

The EGRC-solenoid valve responds to signals from the ECM. When the ECM sends an ON (ground) signal, the coil in the solenoid valve is energized. The vacuum signal (from the intake manifold collector to the EGR valve) passes through the solenoid valve. The signal then reaches the EGR valve. When the ECM sends an OFF signal, a plunger will then move to cut the vacuum signal.

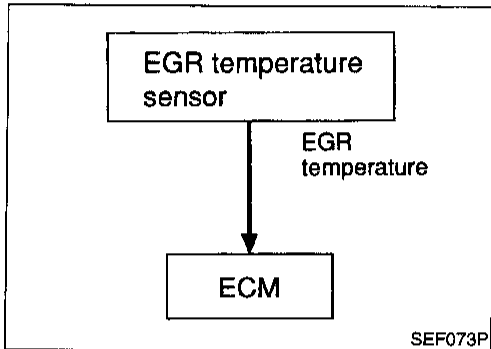

## On Board Diagnosis Logic

NEEC0198

If the absence of EGR flow is detected by EGR temperature sensor under the condition that calls for EGR, a low-flow malfunction is diagnosed.

DTC No.	Malfunction is detected when ...	Check Items (Possible Cause)
P0400 0302	No EGR flow is detected under condition that calls for EGR.	<ul style="list-style-type: none"> <li>• EGR valve stuck closed</li> <li>• EGRC-BPT valve</li> <li>• Vacuum hoses</li> <li>• EGRC-solenoid valve</li> <li>• EGR passage</li> <li>• EGR temperature sensor</li> <li>• Exhaust gas leaks</li> </ul>

GI  
MA  
EM  
LC  
EC  
FE  
CL  
MT  
AT  
TF  
PD  
FA  
RA  
BR  
ST  
RS  
BT  
HA  
EL  
IDX

# DTC P0400 EGR FUNCTION (CLOSE)

## DTC Confirmation Procedure

NEEC0484

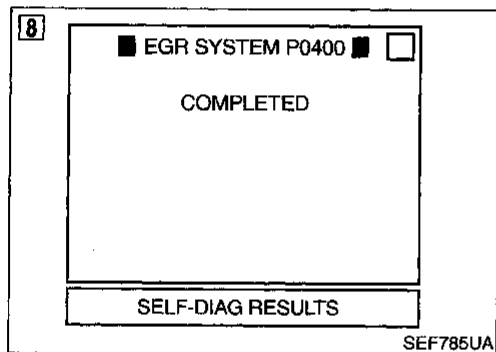
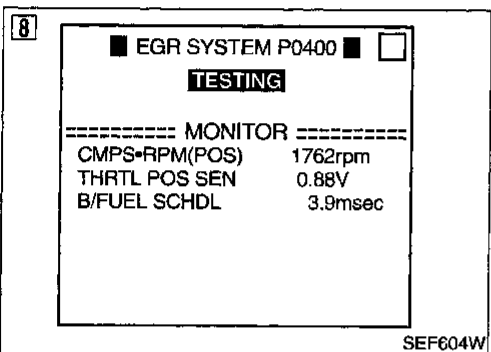
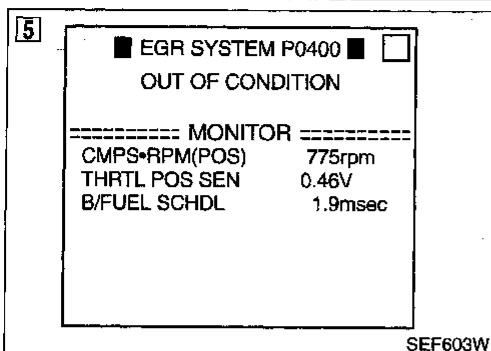

## DTC Confirmation Procedure

### CAUTION:

Always drive vehicle at a safe speed.

### NOTE:

- If "DTC Confirmation Procedure" has been previously conducted, always turn ignition switch "OFF" and wait at least 5 seconds before conducting the next test.
- P0400 will not be displayed at "SELF-DIAG RESULTS" mode with CONSULT even though DTC work support test result is NG.

### TESTING CONDITION:

For best results, perform the test at a temperature of 5°C (41°F) or higher.

#### Ⓔ With CONSULT

- 1) Turn ignition switch "ON"
- 2) Check "COOLAN TEMP/S" in "DATA MONITOR" mode with CONSULT.  
Confirm COOLAN TEMP/S value is within the range listed below.  
**COOLAN TEMP/S: Less than 40°C (104°F)**  
If the value is out of range, park the vehicle in a cool place and allow the engine temperature to stabilize. Do not attempt to lower the engine coolant temperature with a fan or means other than ambient air. Doing so may produce an inaccurate diagnostic result.
- 3) Start engine and let it idle monitoring "COOLAN TEMP/S" value. When the "COOLAN TEMP/S" value reaches 70°C (158°F), immediately go to the next step.
- 4) Select "EGR SYSTEM P0400" of "EGR SYSTEM" in "DTC WORK SUPPORT" mode with CONSULT.
- 5) Touch "START".
- 6) Accelerate vehicle to a speed of 40 km/h (25 MPH) once and then stop vehicle with engine running.  
If "COMPLETED" appears on CONSULT screen, go to step 9.  
If "COMPLETED" does not appear on CONSULT screen, go to the following step.
- 7) Check the output voltage of "THRTL POS SEN" (at closed throttle position) and note it.
- 8) When the following conditions are met, "TESTING" will be displayed on the CONSULT screen. Maintain the conditions until "TESTING" changes to "COMPLETED". (It will take approximately 60 seconds or more.)

CMPS-RPM (POS)	1,600 - 2,400 rpm
B/FUEL SCHDL	3.0 - 4.5 msec
THRTL POS SEN	X - (X + 0.7) V X = Voltage value measured at step 7
Selector lever	Suitable position

If "TESTING" is not displayed after 5 minutes, retry from step 2.

- 9) Make sure that "OK" is displayed after touching "SELF-DIAG RESULTS". If "NG" is displayed, refer to "Diagnostic Procedure", EC-293.



# DTC P0400 EGR FUNCTION (CLOSE)

Overall Function Check

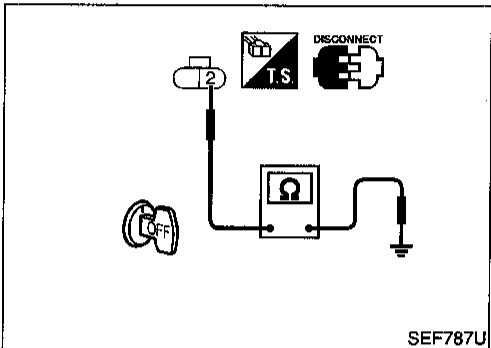
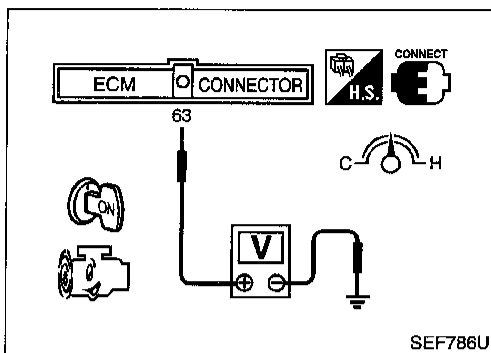

## Overall Function Check

NEEQ0199

Use this procedure to check the overall EGR function. During this check, a 1st trip DTC might not be confirmed.

### ⊗ Without CONSULT

- 1) Start engine and warm it up to normal operating temperature.
- 2) Check the EGR valve lifting when revving engine from idle up to 3,000 rpm quickly under no load.

**EGR valve should lift up and down without sticking.**

If NG, go to "Diagnostic Procedure", EC-293.

- 3) Check voltage between ECM terminal 63 (EGR temperature sensor signal) and ground at idle speed.

**Less than 4.5V should exist.**

If NG, go to next step.

- 4) Turn ignition switch "OFF".
- 5) Disconnect EGR temperature sensor harness connector.
- 6) Check harness continuity between EGR temperature sensor harness connector terminal 2 and ground.

**Continuity should exist.**

- 7) Perform "EGR TEMPERATURE SENSOR", "Component Inspection", EC-388.

### Overall function check

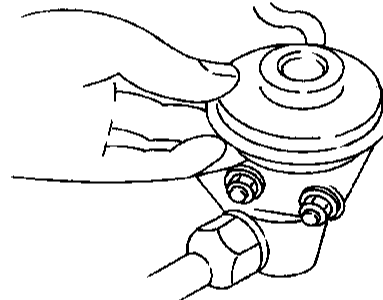
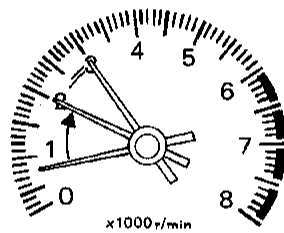

Check the EGR valve lifting when revving engine from idle up to 3,000 rpm quickly.

SEF863U

GI  
MA  
EM  
LC  
EC  
FE  
CL  
MT  
AT  
TF  
PD  
FA  
RA  
BR  
ST  
RS  
BT  
HA  
EL  
IDX



# DTC P0400 EGR FUNCTION (CLOSE)

Diagnostic Procedure

## Diagnostic Procedure

NEEC0201

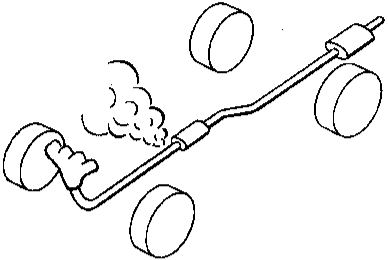
<b>1</b>	<b>CHECK EXHAUST SYSTEM</b>
<ol style="list-style-type: none"> <li>1. Start engine.</li> <li>2. Check exhaust pipes and muffler for leaks.</li> </ol>	
	
SEF099P	
OK or NG	
OK (With CONSULT) ▶	GO TO 2.
OK (Without CONSULT) ▶	GO TO 3.
NG ▶	Repair or replace exhaust system.

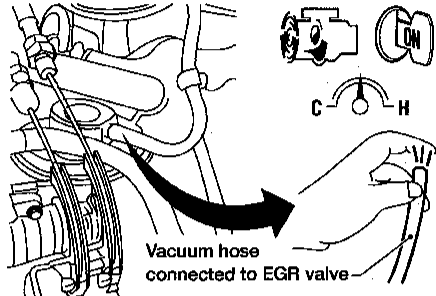
<b>2</b>	<b>CHECK VACUUM SOURCE TO EGR VALVE</b>										
<p><b>Ⓟ With CONSULT</b></p> <ol style="list-style-type: none"> <li>1. Warm engine up to normal operating temperature.</li> <li>2. Disconnect vacuum hose to EGR valve.</li> <li>3. Check for vacuum existence at idle.</li> </ol>											
											
AEC648A											
<p><b>Vacuum should not exist at idle.</b></p> <ol style="list-style-type: none"> <li>4. Select "EGRC SOLENOID VALVE" in "ACTIVE TEST" mode with CONSULT and turn the solenoid valve "ON".</li> <li>5. Check for vacuum existence when revving engine from idle up to 3,000 rpm.</li> </ol>											
<table border="1" style="width: 100%;"> <tr> <td style="text-align: center;"><input checked="" type="checkbox"/> ACTIVE TEST</td> <td style="text-align: center;"><input type="checkbox"/></td> </tr> <tr> <td style="text-align: center;">EGRC SOL/V (EGR)</td> <td style="text-align: center;">ON FLOW</td> </tr> <tr> <td colspan="2" style="text-align: center;">----- MONITOR -----</td> </tr> <tr> <td style="text-align: center;">CMPS•RPM(REF)</td> <td style="text-align: center;">2850rpm</td> </tr> <tr> <td style="text-align: center;"><b>ON</b></td> <td style="text-align: center;"><b>ON/OFF</b>   <b>OFF</b></td> </tr> </table>		<input checked="" type="checkbox"/> ACTIVE TEST	<input type="checkbox"/>	EGRC SOL/V (EGR)	ON FLOW	----- MONITOR -----		CMPS•RPM(REF)	2850rpm	<b>ON</b>	<b>ON/OFF</b> <b>OFF</b>
<input checked="" type="checkbox"/> ACTIVE TEST	<input type="checkbox"/>										
EGRC SOL/V (EGR)	ON FLOW										
----- MONITOR -----											
CMPS•RPM(REF)	2850rpm										
<b>ON</b>	<b>ON/OFF</b> <b>OFF</b>										
SEF788U											
<p><b>Vacuum should exist when revving engine.</b></p>											
OK or NG											
OK ▶	GO TO 4.										
NG ▶	GO TO 5.										

GI  
MA  
EM  
LC  
EC  
FE  
CL  
MT  
AT  
TF  
PD  
FA  
RA  
BR  
ST  
RS  
BT  
HA  
EL  
IDX

# DTC P0400 EGR FUNCTION (CLOSE)

Diagnostic Procedure (Cont'd)

<b>3</b>	<b>CHECK VACUUM SOURCE TO EGR VALVE</b>
<p><b>⊗ Without CONSULT</b></p> <ol style="list-style-type: none"> <li>Warm engine up to normal operating temperature.</li> <li>Disconnect vacuum hose to EGR valve.</li> <li>Check for vacuum existence at idle.</li> </ol>	
<p><b>Vacuum should not exist at idle.</b></p> <ol style="list-style-type: none"> <li>Check for vacuum existence when revving engine from idle up to 3,000 rpm quickly.</li> </ol> <p><b>Vacuum should exist when revving engine.</b></p> <p style="text-align: center;"><b>OK or NG</b></p>	
OK	▶ GO TO 4.
NG	▶ GO TO 5.

<b>4</b>	<b>CHECK EGR VALVE</b>
Refer to "Component Inspection", EC-295.	
<b>OK or NG</b>	
OK	▶ GO TO 11.
NG	▶ Replace EGR valve.

<b>5</b>	<b>CHECK VACUUM HOSE</b>
<ol style="list-style-type: none"> <li>Turn ignition switch "OFF".</li> <li>Check vacuum hose for clogging, cracks or improper connection.</li> </ol>	
SEF109L	
<b>OK or NG</b>	
OK (With CONSULT)	▶ GO TO 6.
OK (Without CONSULT)	▶ GO TO 7.
NG	▶ Repair or replace vacuum hose.

<b>6</b>	<b>CHECK EGRC-SOLENOID VALVE OPERATION</b>						
<p><b>Ⓟ With CONSULT</b></p> <ol style="list-style-type: none"> <li>Turn ignition switch "ON".</li> <li>Perform "EGRC SOL/V CIRCUIT" in "FUNCTION TEST" mode with CONSULT.</li> </ol>							
<table border="1" style="width: 100%;"> <tr> <td colspan="2" style="text-align: center;"><b>■ EGRC SOL/V CIRCUIT ■</b></td> </tr> <tr> <td colspan="2" style="text-align: center;">DOES THE SOLENOID VALVE MAKE AN OPERATING SOUND EVERY 3 SECONDS?</td> </tr> <tr> <td style="text-align: center;">NEXT</td> <td style="text-align: center;">NO YES</td> </tr> </table>		<b>■ EGRC SOL/V CIRCUIT ■</b>		DOES THE SOLENOID VALVE MAKE AN OPERATING SOUND EVERY 3 SECONDS?		NEXT	NO YES
<b>■ EGRC SOL/V CIRCUIT ■</b>							
DOES THE SOLENOID VALVE MAKE AN OPERATING SOUND EVERY 3 SECONDS?							
NEXT	NO YES						
MEF957D							

<p><b>Ⓟ With CONSULT</b></p> <ol style="list-style-type: none"> <li>Turn ignition switch "ON".</li> <li>Turn EGRC-solenoid valve "ON" and "OFF" in "ACTIVE TEST" mode with CONSULT and check operating sound.</li> </ol>											
<table border="1" style="width: 100%;"> <tr> <td colspan="2" style="text-align: center;"><b>■ ACTIVE TEST ■</b></td> </tr> <tr> <td style="text-align: center;">EGRC SOL/V (EGR)</td> <td style="text-align: center;">ON FLOW</td> </tr> <tr> <td colspan="2" style="text-align: center;">===== MONITOR =====</td> </tr> <tr> <td style="text-align: center;">CMPS•RPM(REF)</td> <td style="text-align: center;">0rpm</td> </tr> <tr> <td style="text-align: center;"><b>ON</b></td> <td style="text-align: center;"><b>ON/OFF</b> <b>OFF</b></td> </tr> </table>		<b>■ ACTIVE TEST ■</b>		EGRC SOL/V (EGR)	ON FLOW	===== MONITOR =====		CMPS•RPM(REF)	0rpm	<b>ON</b>	<b>ON/OFF</b> <b>OFF</b>
<b>■ ACTIVE TEST ■</b>											
EGRC SOL/V (EGR)	ON FLOW										
===== MONITOR =====											
CMPS•RPM(REF)	0rpm										
<b>ON</b>	<b>ON/OFF</b> <b>OFF</b>										
SEF789U											
<b>Clicking noise should be heard.</b>											
<b>OK or NG</b>											
OK	▶ GO TO 8.										
NG	▶ Repair or replace EGRC-solenoid valve or repair circuit.										

# DTC P0400 EGR FUNCTION (CLOSE)

Diagnostic Procedure (Cont'd)

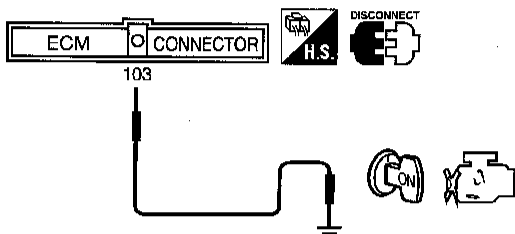
<b>7</b>	<b>CHECK EGRC-SOLENOID VALVE OPERATION</b>
<p><b>⊗ Without CONSULT</b></p> <ol style="list-style-type: none"> <li>1. Disconnect ECM harness connector.</li> <li>2. Turn ignition switch "ON".</li> <li>3. Connect a suitable jumper wire between ECM terminal 103 and engine ground.</li> </ol>	
	
<p>4. Check operating sound of EGRC-solenoid valve when disconnecting and connecting the jumper wire. <b>Clicking noise should be heard.</b></p> <p style="text-align: right;">SEF354V</p>	
<b>OK or NG</b>	
OK	▶ GO TO 8.
NG	▶ Repair or replace EGRC-solenoid valve or repair circuit.

<b>8</b>	<b>CHECK EGRC-SOLENOID VALVE</b>
Refer to "Component Inspection", EC-380.	
<b>OK or NG</b>	
OK	▶ GO TO 9.
NG	▶ Replace EGRC-solenoid valve.

<b>9</b>	<b>CHECK EGRC-BPT VALVE</b>
Refer to "Component Inspection", EC-295.	
<b>OK or NG</b>	
OK	▶ GO TO 10.
NG	▶ Replace EGRC-BPT valve.

<b>10</b>	<b>CHECK EGR TEMPERATURE SENSOR</b>
Refer to "Component Inspection", EC-388.	
<b>OK or NG</b>	
OK	▶ GO TO 11.
NG	▶ Replace EGR temperature sensor.

<b>11</b>	<b>CHECK INTERMITTENT INCIDENT</b>
Refer to "TROUBLE DIAGNOSIS FOR INTERMITTENT INCIDENT", EC-115.	
<b>▶ INSPECTION END</b>	

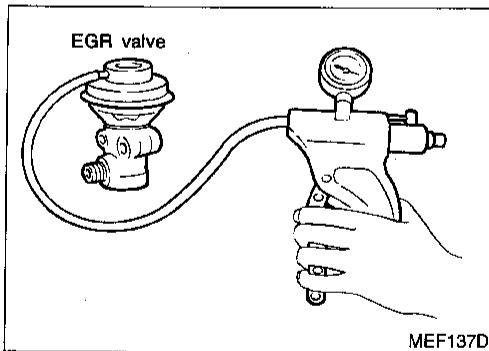

## Component Inspection EGR VALVE

NEEC0202

Apply vacuum to EGR vacuum port with a hand vacuum pump. **EGR valve spring should lift.**

NEEC0202S01

- Check for sticking.
- If NG, repair or replace EGR valve.

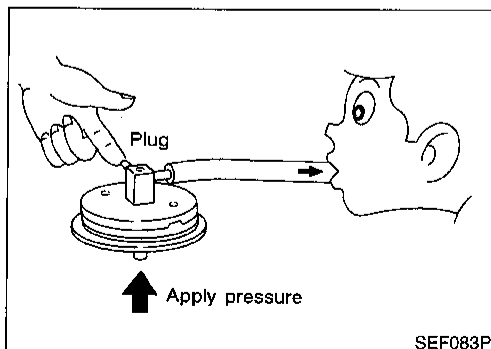

## EGRC-BPT VALVE

NEEC0202S04

1. Plug one of two ports of EGRC-BPT valve.
2. Vacuum from the other port and check for leakage while applying a pressure above 0.981 kPa (100 mmH<sub>2</sub>O, 3.94 inH<sub>2</sub>O) from under EGRC-BPT valve.
3. If a leakage is noted, replace the valve.

GI  
MA  
EM  
LC  
EC  
FE  
CL  
MT  
AT  
TF  
PD  
FA  
RA  
BR  
ST  
RS  
BT  
HA  
EL  
JDX

# DTC P0402 EGRC-BPT VALVE FUNCTION

Description

## Description

NEEC0203

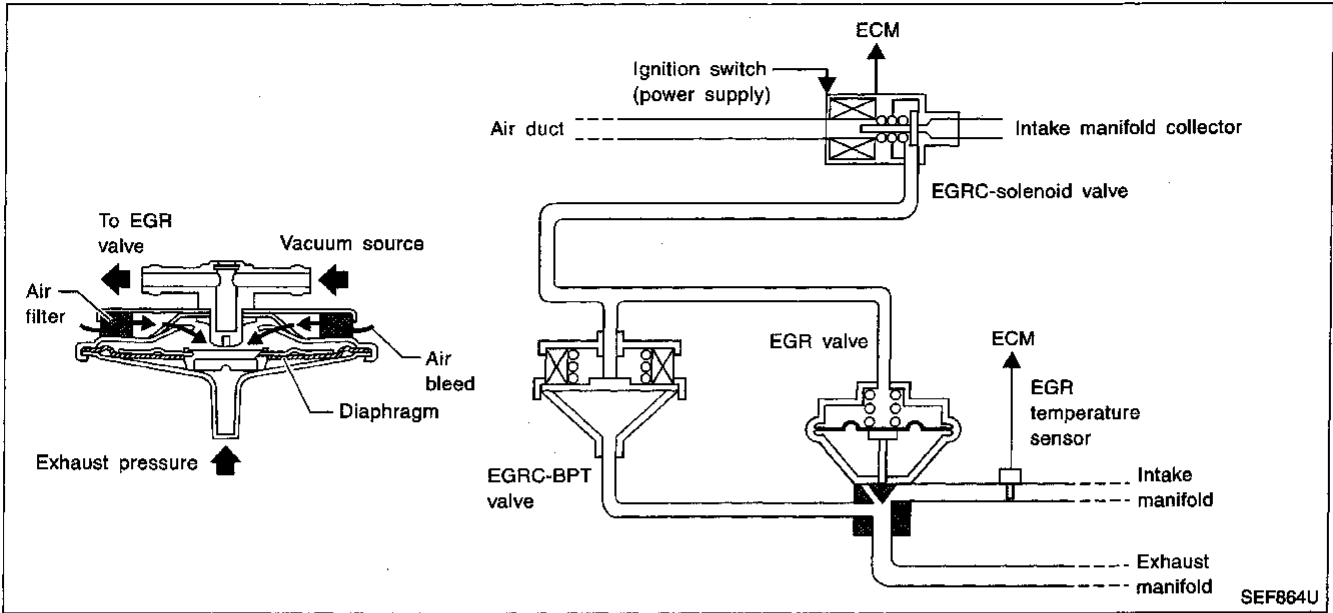

SEF864U

## SYSTEM DESCRIPTION

NEEC0203S01

The EGRC-BPT valve monitors exhaust pressure to activate the diaphragm, controlling intake manifold vacuum applied to the EGR valve. In other words, recirculated exhaust gas is controlled in response to positioning of the EGR valve or to engine operation.

## On Board Diagnosis Logic

NEEC0204

If too much EGR flow exists due to an EGRC-BPT valve malfunction, off idle engine roughness will increase. If the roughness is large, then the vacuum to the EGR valve is interrupted through the EGRC-solenoid valve. If the engine roughness is reduced at that time, the EGRC-BPT valve malfunction is indicated.

DTC No.	Malfunction is detected when ...	Check Items (Possible Cause)
P0402 0306	<ul style="list-style-type: none"> <li>The EGRC-BPT valve does not operate properly.</li> </ul>	<ul style="list-style-type: none"> <li>EGRC-BPT valve</li> <li>EGR valve</li> <li>Loose or disconnected rubber tube</li> <li>Blocked rubber tube</li> <li>Camshaft position sensor</li> <li>Blocked exhaust system</li> <li>Orifice</li> <li>Mass air flow sensor</li> <li>EGRC-solenoid valve</li> </ul>

# DTC P0402 EGRC-BPT VALVE FUNCTION

DTC Confirmation Procedure

NEEC0465

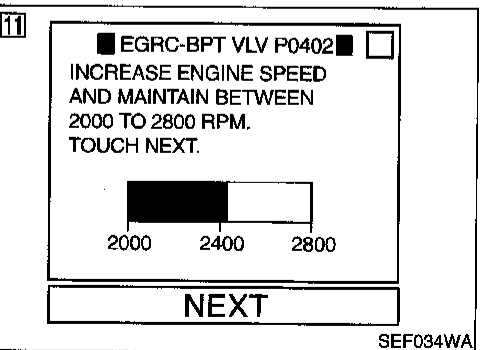
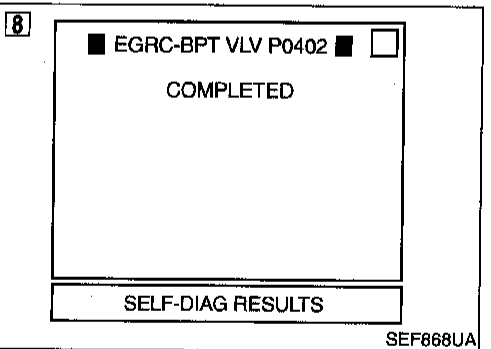
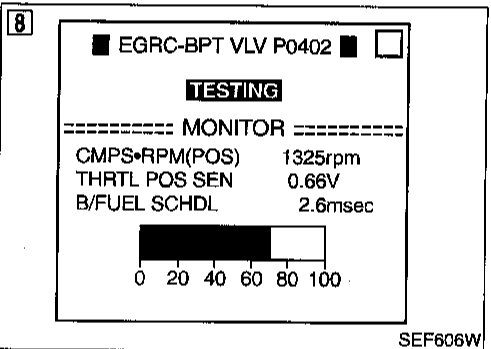
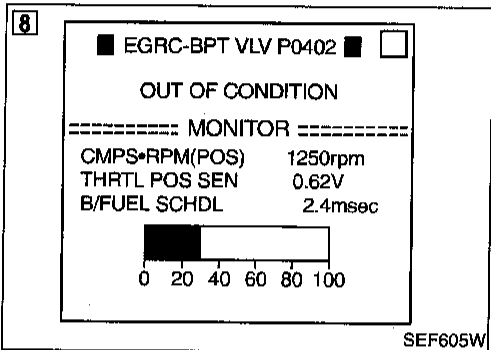
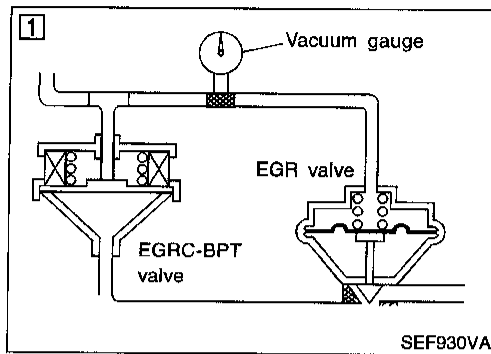

## DTC Confirmation Procedure

### CAUTION:

Always drive vehicle at a safe speed.

### NOTE:

If "DTC Confirmation Procedure" has been previously conducted, always turn ignition switch "OFF" and wait at least 5 seconds before conducting the next test.

### TESTING CONDITION

For best results, perform the test at a temperature of 5°C (41°F) or higher.

#### ⓑ With CONSULT

- 1) Install vacuum gauge between EGRC-BPT valve and EGR valve as shown in the illustration.
- 2) Start engine and warm it up to normal operating temperature.
- 3) Stop engine and wait at least 5 seconds.
- 4) Turn ignition switch "ON" and select "EGRC-BPT/V P0402" of "EGR SYSTEM" in "DTC WORK SUPPORT" mode with CONSULT.
- 5) Start engine and let it idle.
- 6) Touch "START".
- 7) Check the output voltage of "THRTL POS SEN" (at closed throttle position) and note it.
- 8) When the following conditions are met, "TESTING" will be displayed on the CONSULT screen and the bar chart may increase. Maintain the conditions many times until "COMPLETED" appears.

CMPS-RPM (POS)	1,400 - 1,800 rpm
Vehicle speed	30 - 60 km/h (19 - 37 MPH)
B/FUEL SCHDL	2.3 - 2.7 msec
THRTL POS SEN	$X - (X + 0.44) V$ X = Voltage value measured at step 7
Selector lever	Suitable position

- The bar chart on CONSULT screen indicates the status of this test. However, the test may be finished before the bar chart becomes full scale.
  - If the bar chart indication does not continue to progress, completely release accelerator pedal once and try to meet the conditions again.
  - If "TESTING" does not appear on CONSULT screen, retry from step 3.
- 9) If CONSULT instructs to carry out "OVERALL FUNCTION CHECK", go to next step. If "NG" is displayed, refer to "Diagnostic Procedure", EC-298.
  - 10) Open engine hood.
  - 11) Raise engine speed to 2,000 to 2,800 rpm under no-load and hold it. Then touch "NEXT" on CONSULT screen.

## DTC P0402 EGRC-BPT VALVE FUNCTION

DTC Confirmation Procedure (Cont'd)

12

EGRC-BPT VLV P0402

**MAINTAIN ENGINE SPEED  
2000 TO 2800 RPM.  
VACUUM SHOULD BE  
BETWEEN -5.91 in.Hg AND  
0 in.Hg WITH VACUUM  
GAUGE. IS VACUUM OK?**

NG

OK

-23.62

-5.91

0

NO

YES

SEF035WA

12) Check vacuum gauge while keeping engine speed 2,000 to 2,800 rpm.

**Vacuum should be 0 to -20 kPa (0 to -150 mmHg, 0 to -5.91 inHg).**

If NG, go to "Diagnostic Procedure", EC-298.

If OK, touch "YES" on the CONSULT screen.

13) Check the rubber tube between intake manifold collector, EGRC-solenoid valve, EGR valve and EGRC-BPT valve for cracks, blockages or twist.

If NG, repair or replace.

If OK, touch "YES" on the CONSULT screen.

### Overall Function Check

Use this procedure to check the overall function of the EGRC-BPT valve. During this check, a 1st trip DTC might not be confirmed.

#### ⊗ Without CONSULT

1) Install vacuum gauge between EGRC-BPT valve and EGR valve as shown in the illustration.

2) Lift up vehicle.

3) Start engine and shift to "1st" gear or "1" position.

4) Check vacuum gauge while keeping engine speed 2,000 to 2,800 rpm.

**Vacuum should be 0 to -20 kPa (0 to -150 mmHg, 0 to -5.91 inHg).**

If NG, go to "Diagnostic Procedure", EC-298.

If OK, go to next step.

5) Check rubber tube between intake manifold collector, EGRC-solenoid valve, EGR valve and EGRC-BPT valve for misconnections, cracks or blockages.

If NG, repair or replace.

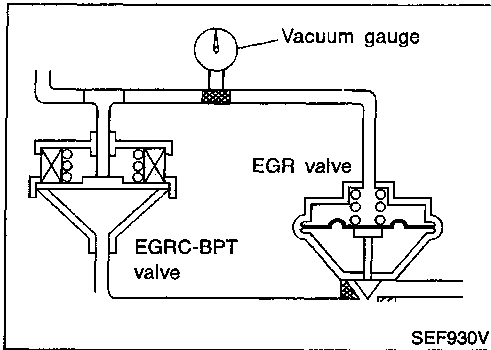

### Diagnostic Procedure

NEEC0486

<b>1</b>	<b>CHECK HOSE</b>
1. Turn ignition switch "OFF". 2. Check vacuum hose for clogging and improper connection.	
<b>OK or NG</b>	
OK	▶ GO TO 2.
NG	▶ Repair or replace vacuum hose.

<b>3</b>	<b>CHECK ORIFICE</b>
Check if orifice is installed in vacuum hose between EGRC-BPT valve and EGRC-solenoid valve.	
<b>OK or NG</b>	
OK	▶ GO TO 4.
NG	▶ Replace vacuum hose.

<b>2</b>	<b>CHECK EXHAUST SYSTEM</b>
Check exhaust system for collapse.	
<b>OK or NG</b>	
OK	▶ GO TO 3.
NG	▶ Repair or replace exhaust system.

<b>4</b>	<b>CHECK EGRC-BPT VALVE</b>
Refer to "Component Inspection", EC-299.	
<b>OK or NG</b>	
OK	▶ GO TO 5.
NG	▶ Replace EGRC-BPT valve.



# DTC P0402 EGRC-BPT VALVE FUNCTION

Diagnostic Procedure (Cont'd)

<b>5</b>	<b>CHECK CAMSHAFT POSITION SENSOR</b>
Refer to "Component Inspection", EC-286.	
<b>OK or NG</b>	
OK	▶ GO TO 6.
NG	▶ Replace camshaft position sensor.

<b>8</b>	<b>CHECK EGR VALVE</b>
Refer to "Component Inspection", EC-295.	
<b>OK or NG</b>	
OK	▶ GO TO 9.
NG	▶ Replace EGR valve.

<b>6</b>	<b>CHECK MASS AIR FLOW SENSOR</b>
Refer to "Component Inspection", EC-129.	
<b>OK or NG</b>	
OK	▶ GO TO 7.
NG	▶ Replace mass air flow sensor.

<b>9</b>	<b>CHECK INTERMITTENT INCIDENT</b>
Refer to "TROUBLE DIAGNOSIS FOR INTERMITTENT INCIDENT", EC-115.	
▶ <b>INSPECTION END</b>	

<b>7</b>	<b>CHECK EGRC-SOLENOID VALVE</b>
Refer to "Component Inspection", EC-380.	
<b>OK or NG</b>	
OK	▶ GO TO 8.
NG	▶ Replace EGRC-solenoid valve.

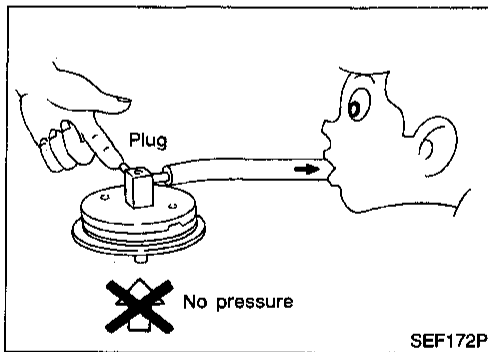

## Component Inspection EGRC-BPT VALVE

1. Plug one of two ports of EGRC-BPT valve.
2. Vacuum from the other port and check leakage without applying any pressure from under EGR-BPT valve.  
**Leakage should exist.**

NEEC0206

NEEC0206S01

CI  
MA  
EM  
LC  
EC  
FE  
CL  
MT  
AT  
TF  
PD  
FA  
RA  
BR  
ST  
RS  
BT  
HA  
EL  
IDX

# DTC P0420 (RIGHT BANK, -B1), P0430 (LEFT BANK, -B2) THREE WAY CATALYST FUNCTION

On Board Diagnosis Logic

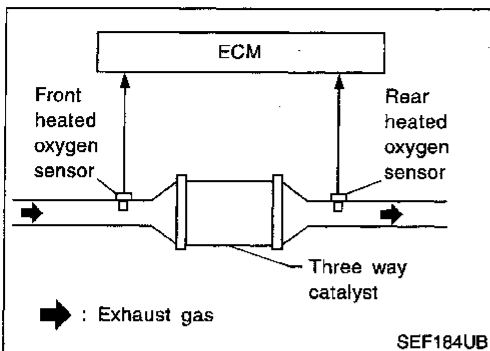

## On Board Diagnosis Logic

NEEC0207

The ECM monitors the switching frequency ratio of front and rear heated oxygen sensors.

A warm-up three way catalyst with high oxygen storage capacity will indicate a low switching frequency of rear heated oxygen sensor. As oxygen storage capacity decreases, the rear heated oxygen sensor switching frequency will increase.

When the frequency ratio of front and rear heated oxygen sensors approaches a specified limit value, the warm-up three way catalyst malfunction is diagnosed.

DTC No.	Malfunction is detected when ...	Check Items (Possible Cause)
P0420 0702 (right bank)	<ul style="list-style-type: none"> <li>• Warm-up three way catalyst does not operate properly.</li> <li>• Warm-up three way catalyst does not have enough oxygen storage capacity.</li> </ul>	<ul style="list-style-type: none"> <li>• Warm-up three way catalyst</li> <li>• Exhaust tube</li> <li>• Intake air leaks</li> <li>• Injectors</li> <li>• Injector leaks</li> <li>• Spark plug</li> <li>• Improper ignition timing</li> </ul>
P0430 0703 (left bank)		

4

☆ MONITOR ☆ NO FAIL

CMPS•RPM(POS)	2137rpm
FR O2 SEN-B1	0.37V
FR O2 SEN-B2	0.37V
RR O2 SEN-B1	0.32V
RR O2 SEN-B2	0.32V
FR O2 MNTR-B1	LEAN
FR O2 MNTR-B2	LEAN
RR O2 MNTR-B1	LEAN
RR O2 MNTR-B2	LEAN

RECORD

SEF718W

8

■ SRT STATUS ■

CATALYST	CMPLT
EVAP SYSTEM	INCMP
O2 SENSOR	CMPLT
O2 SEN HEATER	CMPLT
EGR SYSTEM	INCMP

PRINT

AEC908A

## DTC Confirmation Procedure

NEEC0467

### CAUTION:

Always drive vehicle at a safe speed.

### NOTE:

If "DTC Confirmation Procedure" has been previously conducted, always turn ignition switch "OFF" and wait at least 5 seconds before conducting the next test.

### With CONSULT

- 1) Start engine and drive vehicle at a speed of more than 70 km/h (43 MPH) for 2 consecutive minutes.
- 2) Stop vehicle with engine running.
- 3) Set "MANU TRIG" and "HI SPEED", then select "FR O2 SEN-B1 (-B2)", "RR O2 SEN-B1 (-B2)", "FR O2 MNTR-B1 (-B2)", "RR O2 MNTR-B1 (-B2)" in "DATA MONITOR" mode with CONSULT.
- 4) Touch "RECORD" on CONSULT screen with engine speed held at 2,000 rpm constantly under no load.
- 5) Make sure that the switching frequency between "RICH" and "LEAN" of "RR O2 MNTR-B1 (-B2)" is much less than that of "FR O2 MNTR-B1 (-B2)" as shown below.

Switching frequency ratio = A/B

**A:** Rear heated oxygen sensor switching frequency

**B:** Front heated oxygen sensor switching frequency

This ratio should be less than 0.75.

If the ratio is greater than above, the warm-up three way catalyst is not operating properly.

If the "FR O2 MNTR-B1 (-B2)" does not indicate "RICH" and "LEAN" periodically more than 5 times within 10 seconds at step 4, perform trouble diagnosis for "DTC P0133, P0153" first. (See EC-186.)

If the result is NG, go to "Diagnostic Procedure", EC-301.

If the result is OK, go to following step.

- 6) Select "AUTO TRIG" in "DATA MONITOR" mode with CONSULT.

# DTC P0420 (RIGHT BANK, -B1), P0430 (LEFT BANK, -B2) THREE WAY CATALYST FUNCTION

DTC Confirmation Procedure (Cont'd)

- 7) Drive vehicle at a speed of approximately 86 to 96 km/h (53 to 60 MPH) with "D" position ("OD" ON) (A/T), 5th gear position (M/T) for at least 10 consecutive minutes.  
(Drive the vehicle in an area where vehicle speed and accelerator pressure can be held steady and constant.)  
If the result is NG, go to "Diagnostic Procedure", EC-301.
- 8) Select "SRT STATUS" in "DTC CONFIRMATION" mode with CONSULT.
- 9) Verify that "CATALYST" is "CMPLT".  
If not "CMPLT", repeat the test from step 6.

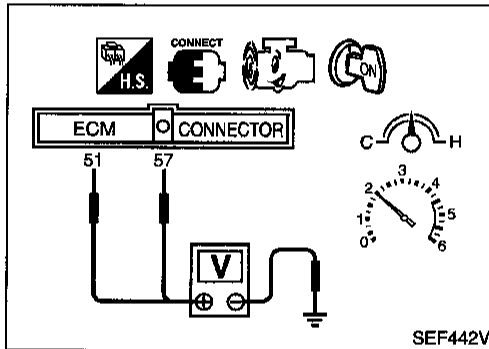
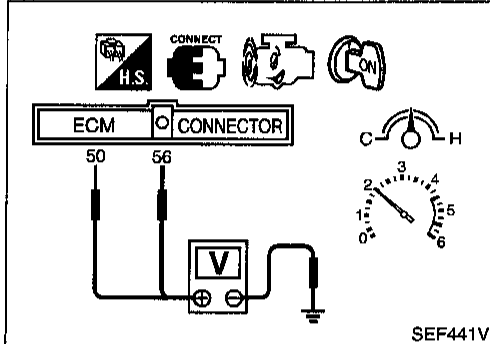

## Overall Function Check

NEEC0208

Use this procedure to check the overall function of the warm-up three way catalyst. During this check, a 1st trip DTC might not be confirmed.

### ⊗ Without CONSULT

- 1) Start engine and drive vehicle at a speed of more than 70 km/h (43 MPH) for 2 consecutive minutes.
- 2) Stop vehicle with engine running.
- 3) Set voltmeters probes between ECM terminals 50 (front heated oxygen sensor right bank signal), 51 (front heated oxygen sensor left bank signal) and engine ground, and ECM terminals 56 (rear heated oxygen sensor right bank signal), 57 (rear heated oxygen sensor left bank signal) and engine ground.
- 4) Keep engine speed at 2,000 rpm constant under no load.
- 5) Make sure that the voltage switching frequency (high & low) between ECM terminals 56 and engine ground, or 57 and engine ground is very less than that of ECM terminals 50 and engine ground, or 51 and engine ground.

**Switching frequency ratio = A/B**

**A: Rear heated oxygen sensor voltage switching frequency**

**B: Front heated oxygen sensor voltage switching frequency**

**This ratio should be less than 0.75.**

If the ratio is greater than above, it means warm-up three way catalyst does not operate properly. Go to "Diagnostic Procedure", EC-301.

### NOTE:

If the voltage at terminal 50 or 51 does not switch periodically more than 5 times within 10 seconds at step 5, perform trouble diagnosis for "DTC P0133, P0153" first. (See EC-186.)

## Diagnostic Procedure

NEEC0209

<b>1</b>	<b>CHECK EXHAUST SYSTEM</b>	
Visually check exhaust tubes and muffler for dent.		
<b>OK or NG</b>		
OK	▶	GO TO 2.
NG	▶	Repair or replace it.

GI  
MA  
EM  
LC  
EC  
FE  
CL  
MT  
AT  
TF  
PD  
FA  
RA  
BR  
ST  
RS  
BT  
HA  
EL  
IDX

# DTC P0420 (RIGHT BANK, -B1), P0430 (LEFT BANK, -B2) THREE WAY CATALYST FUNCTION

Diagnostic Procedure (Cont'd)

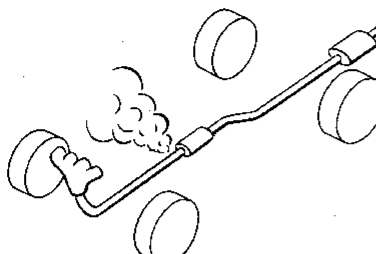
<b>2</b>	<b>CHECK EXHAUST AIR LEAK</b>
<ol style="list-style-type: none"> <li>1. Start engine and run it at idle.</li> <li>2. Listen for an exhaust air leak before the warm-up three way catalyst.</li> </ol>	
	
SEF099P	
<b>OK or NG</b>	
OK	▶ GO TO 3.
NG	▶ Repair or replace.

<b>3</b>	<b>CHECK INTAKE AIR LEAK</b>
Listen for an intake air leak after the mass air flow sensor.	
<b>OK or NG</b>	
OK	▶ GO TO 4.
NG	▶ Repair or replace.

<b>4</b>	<b>CHECK IGNITION TIMING</b>
Check ignition timing. Refer to "TROUBLE DIAGNOSIS — BASIC INSPECTION", EC-86.	
<b>OK or NG</b>	
OK	▶ GO TO 5.
NG	▶ Adjust ignition timing.

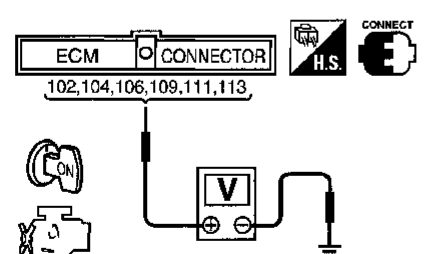
<b>5</b>	<b>CHECK INJECTORS</b>
<ol style="list-style-type: none"> <li>1. Refer to WIRING DIAGRAM for Injectors, EC-460.</li> <li>2. Stop engine and then turn ignition switch "ON".</li> <li>3. Check voltage between ECM terminals 102, 104, 106, 109, 111 and 113 and ground with CONSULT or tester.</li> </ol>	
	
Battery voltage should exist.	
SEF711U	
<b>OK or NG</b>	
OK	▶ GO TO 6.
NG	▶ Perform "Diagnostic Procedure", "INJECTOR", EC-461.

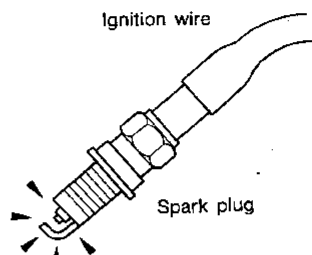
<b>6</b>	<b>CHECK IGNITION SPARK</b>
<ol style="list-style-type: none"> <li>1. Turn ignition switch "OFF".</li> <li>2. Disconnect ignition wire from spark plug.</li> <li>3. Connect a known good spark plug to the ignition wire.</li> <li>4. Place end of spark plug against a suitable ground and crank engine.</li> <li>5. Check for spark.</li> </ol>	
	
SEF282G	
<b>OK or NG</b>	
OK	▶ GO TO 8.
NG	▶ GO TO 7.

<b>7</b>	<b>CHECK IGNITION WIRES</b>
Refer to "Component Inspection", EC-270.	
<b>OK or NG</b>	
OK	▶ Check ignition coil, power transistor and their circuits. Refer to EC-366.
NG	▶ Replace.

<b>8</b>	<b>CHECK INJECTOR</b>
<ol style="list-style-type: none"> <li>1. Turn ignition switch "OFF".</li> <li>2. Remove injector assembly. Refer to EC-32. Keep fuel hose and all injectors connected to injector gallery.</li> <li>3. Disconnect all ignition coil harness connectors.</li> <li>4. Turn ignition switch "ON". Make sure fuel does not drip from injector.</li> </ol>	
<b>OK or NG</b>	
OK (Does not drip)	▶ GO TO 9.
NG (Drips)	▶ Replace the injector(s) from which fuel is dripping.

<b>9</b>	<b>CHECK INTERMITTENT INCIDENT</b>
Refer to "TROUBLE DIAGNOSIS FOR INTERMITTENT INCIDENT", EC-115.	
Trouble is fixed	▶ <b>INSPECTION END</b>
Trouble is not fixed	▶ Replace warm-up three way catalyst.

# DTC P0440 EVAPORATIVE EMISSION (EVAP) CONTROL SYSTEM (SMALL LEAK) (NEGATIVE PRESSURE)

On Board Diagnosis Logic

## On Board Diagnosis Logic

NEEC0210

### NOTE:

If DTC P0440 is displayed with P1448, perform trouble diagnosis for DTC P1448 first. (See EC-420.)

This diagnosis detects leaks in the EVAP purge line using engine intake manifold vacuum.

If pressure does not increase, the ECM will check for leaks in the line between the fuel tank and EVAP canister purge volume control solenoid valve, under the following "Vacuum test" conditions.

The vacuum cut valve bypass valve is opened to clear the line between the fuel tank and the EVAP canister purge volume control solenoid valve. The EVAP canister vent control valve will then be closed to shut the EVAP purge line off. The EVAP canister purge volume control solenoid valve is opened to depressurize the EVAP purge line using intake manifold vacuum. After this occurs, the EVAP canister purge volume control solenoid valve will be closed.

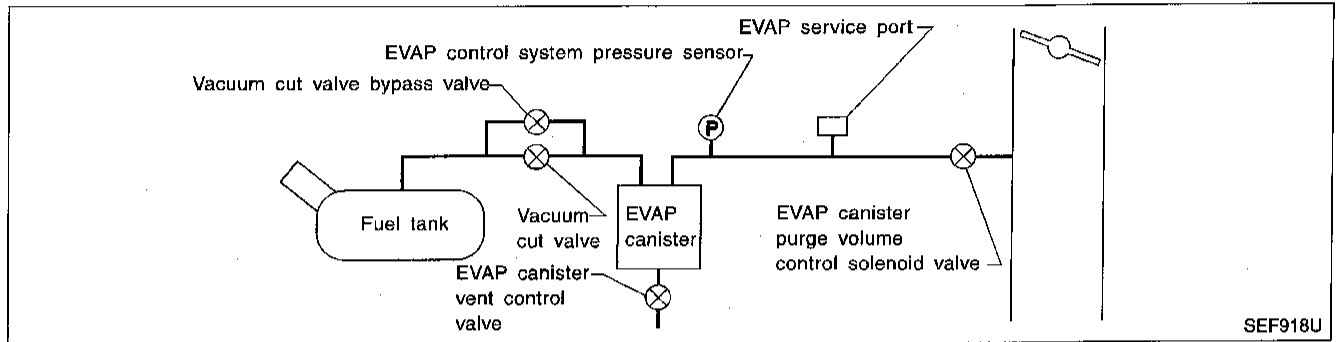

DTC No.	Malfunction is detected when ...	Check Items (Possible Cause)
P0440 0705	<ul style="list-style-type: none"> <li>• EVAP control system has a leak.</li> <li>• EVAP control system does not operate properly.</li> </ul>	<ul style="list-style-type: none"> <li>• Incorrect fuel tank vacuum relief valve</li> <li>• Incorrect fuel filler cap used</li> <li>• Fuel filler cap remains open or fails to close.</li> <li>• Foreign matter caught in fuel filler cap.</li> <li>• Leak is in line between intake manifold and EVAP canister purge volume control solenoid valve.</li> <li>• Foreign matter caught in EVAP canister vent control valve.</li> <li>• EVAP canister or fuel tank leaks</li> <li>• EVAP purge line (pipe and rubber tube) leaks</li> <li>• EVAP purge line rubber tube bent.</li> <li>• Blocked or bent rubber tube to EVAP control system pressure sensor</li> <li>• Loose or disconnected rubber tube</li> <li>• EVAP canister vent control valve and the circuit</li> <li>• EVAP canister purge volume control solenoid valve and the circuit</li> <li>• Absolute pressure sensor</li> <li>• Tank fuel temperature sensor</li> <li>• MAP/BARO switch solenoid valve and the circuit</li> <li>• Blocked or bent rubber tube to MAP/BARO switch solenoid valve and the circuit</li> <li>• O-ring of EVAP canister vent control valve is missing or damaged.</li> <li>• Water separator</li> <li>• EVAP canister is saturated with water.</li> <li>• EVAP control system pressure sensor</li> </ul>

### CAUTION:

- Use only a genuine NISSAN fuel filler cap as a replacement. If an incorrect fuel filler cap is used, the MIL may come on.
- If the fuel filler cap is not tightened properly, the MIL may come on.
- Use only a genuine NISSAN rubber tube as a replacement.

# DTC P0440 EVAPORATIVE EMISSION (EVAP) CONTROL SYSTEM (SMALL LEAK) (NEGATIVE PRESSURE)

## DTC Confirmation Procedure

■ EVAP SML LEAK P0440 ■

1)PERFORM TEST AT A LOCATION OF 0-30C (32-86F)  
 2)OPEN ENGINE HOOD.  
 3)START ENGINE WITH VEHICLE STOPPED. IF ENG IS ON, STOP FOR 5 SEC. THEN RESTART.  
 4)TOUCH START.

EXIT
START

SEF405W

5
■ EVAP SML LEAK P0440 ■

WAIT. . .

2 TO 10 MINUTES  
KEEP ENGINE RUNNING  
AT IDLE SPEED.

SEF929V

5
■ EVAP SML LEAK P0440 ■

CAN NOT BE DIAGNOSED

FUEL TEMPERATURE IS TOO HIGH. RETEST AFTER FUEL HAS COOLED.

EXIT
PRINT

AEC910A

6
■ EVAP SML LEAK P0440 ■

\*\*\*\*\* OK \*\*\*\*\*

END
PRINT

AEC911A

## DTC Confirmation Procedure

NEEC0211

### NOTE:

- If DTC P0440 is displayed with P1448, perform trouble diagnosis for DTC P1448 first. (See EC-420.)
- If "DTC Confirmation Procedure" has been previously conducted, always turn ignition switch "OFF" and wait at least 5 seconds before conducting the next test.

### TESTING CONDITION:

- Perform "DTC WORK SUPPORT" when the fuel level is less than 3/4 full and vehicle is placed on flat level surface.
- Always perform test at a temperature of 0 to 30°C (32 to 86°F).
- It is better that the fuel level is low.

### Ⓟ With CONSULT

- 1) Turn ignition switch "ON".
- 2) Turn ignition switch "OFF" and wait at least 5 seconds.
- 3) Turn ignition switch "ON" and select "DATA MONITOR" mode with CONSULT.
- 4) Make sure that the following conditions are met.  
**COOLAN TEMP/S: 0 - 70°C (32 - 158°F)**  
**INT/A TEMP SE: 0 - 60°C (32 - 140°F)**
- 5) Select "EVAP SML LEAK P0440" of "EVAPORATIVE SYSTEM" in "DTC WORK SUPPORT" mode with CONSULT. Follow the instruction displayed.

### NOTE:

- If the CONSULT screen shown at left is displayed, stop the engine and stabilize the vehicle temperature at 25°C (77°F) or cooler. After "TANK F/TMP SE" becomes less than 30°C (86°F), retest. (Use a fan to reduce the stabilization time.)
- If the engine speed cannot be maintained within the range displayed on the CONSULT screen, go to "Basic Inspection", EC-86.
- 6) Make sure that "OK" is displayed. If "NG" is displayed, refer to "Diagnostic Procedure", EC-305.

### NOTE:

**Make sure that EVAP hoses are connected to EVAP canister purge volume control solenoid valve properly.**

### Ⓟ With GST

### NOTE:

- Be sure to read the explanation of "Driving Pattern" on EC-49 before driving vehicle.
  - It is better that the fuel level is low.
- 1) Start engine.
  - 2) Drive vehicle according to "Driving Pattern", EC-49.
  - 3) Stop vehicle.
  - 4) Select "MODE 1" with GST.
    - If SRT of EVAP system is not set yet, go to the following step.
    - If SRT of EVAP system is set, the result will be OK.
  - 5) Turn ignition switch "OFF" and wait at least 5 seconds.
  - 6) Start engine.
    - It is not necessary to cool engine down before driving.**
  - 7) Drive vehicle again according to the "Driving Pattern", EC-49.
  - 8) Stop vehicle.
  - 9) Select "MODE 3" with GST.

## EC-304

# DTC P0440 EVAPORATIVE EMISSION (EVAP) CONTROL SYSTEM (SMALL LEAK) (NEGATIVE PRESSURE)

DTC Confirmation Procedure (Cont'd)

- If P0440 is displayed on the screen, go to "Diagnostic Procedure", EC-305.
  - If P1440 is displayed on the screen, go to "Diagnostic Procedure" for "DTC P1440", EC-397.
  - If P1447 is displayed on the screen, go to "Diagnostic Procedure" for "DTC P1447", EC-417.
  - If P0440, P1440 and P1447 are not displayed on the screen, go to the following step.
- 10) Select "MODE 1" with GST.
- If SRT of EVAP system is set, the result will be OK.
  - If SRT of EVAP system is not set, go to step 6.

 **No Tools**

**NOTE:**

- Be sure to read the explanation of "Driving Pattern" on EC-49 before driving vehicle.
  - It is better that the fuel level is low.
- 1) Start engine.
  - 2) Drive vehicle according to "Driving Pattern", EC-49.
  - 3) Stop vehicle.
  - 4) Turn ignition switch "OFF" and wait at least 5 seconds.
  - 5) Turn ignition switch "ON" and perform "Diagnostic Test Mode II (Self-diagnostic results)" with ECM.
  - 6) If 1st trip DTC is detected, go to "Diagnostic Procedure", EC-305.

## Diagnostic Procedure

NEEC0212

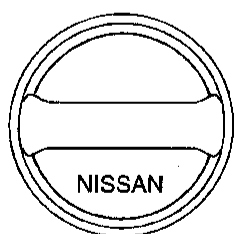
<b>1</b>	<b>CHECK FUEL FILLER CAP DESIGN</b>
1. Turn ignition switch "OFF". 2. Check for genuine NISSAN fuel filler cap design.	
	
SEF915U	
<b>OK or NG</b>	
OK	▶ GO TO 2.
NG	▶ Replace with genuine NISSAN fuel filler cap.

<b>2</b>	<b>CHECK FUEL FILLER CAP INSTALLATION</b>
Check that the cap is tightened properly by rotating the cap clockwise.	
<b>OK or NG</b>	
OK	▶ GO TO 3.
NG	▶ <ul style="list-style-type: none"> <li>• Open fuel filler cap, then clean cap and fuel filler neck threads using air blower.</li> <li>• Retighten until ratcheting sound is heard.</li> </ul>

<b>3</b>	<b>CHECK FUEL FILLER CAP FUNCTION</b>
Check for air releasing sound while opening the fuel filler cap.	
<b>OK or NG</b>	
OK	▶ GO TO 6.
NG	▶ GO TO 4.



GI  
MA  
EM  
LC  
EC  
FE  
CL  
MT  
AT  
TF  
PD  
FA  
RA  
BR  
ST  
RS  
BT  
HA  
EL  
IDX

# DTC P0440 EVAPORATIVE EMISSION (EVAP) CONTROL SYSTEM (SMALL LEAK) (NEGATIVE PRESSURE)

Diagnostic Procedure (Cont'd)

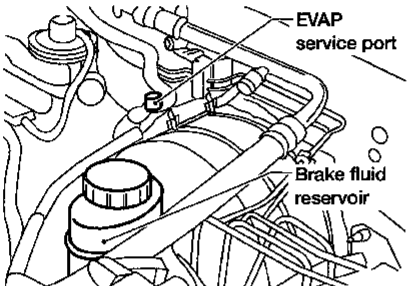
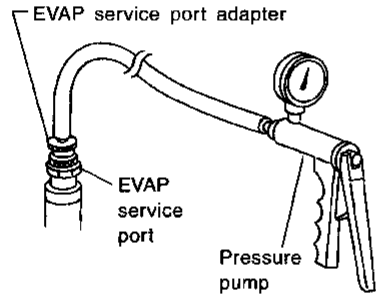
<b>4</b>	<b>CHECK FUEL TANK VACUUM RELIEF VALVE</b>	
Refer to "Evaporative Emission System", EC-24.		
<b>OK or NG</b>		
OK	▶	GO TO 5.
NG	▶	Replace fuel filler cap with a genuine one.

<b>5</b>	<b>INSTALL THE PRESSURE PUMP</b>	
To locate the EVAP leak, install EVAP service port adapter and pressure pump to EVAP service port securely.		
		
AEC649A		
		
SEF916U		
<b>NOTE:</b> Improper installation of the EVAP service port adapter to the EVAP service port may cause leaking.		
Models with CONSULT	▶	GO TO 6.
Models without CONSULT	▶	GO TO 7.

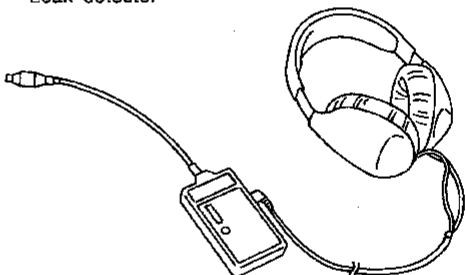
<b>6</b>	<b>CHECK FOR EVAP LEAK</b>	
<p> <b>With CONSULT</b></p> <ol style="list-style-type: none"> <li>1. Turn ignition switch "ON".</li> <li>2. Select "EVAP SYSTEM CLOSE" of "WORK SUPPORT" mode with CONSULT.</li> <li>3. Touch "START" and apply pressure into the EVAP line until the pressure indicator reaches the middle of the bar graph.</li> </ol> <p><b>NOTE:</b></p> <ul style="list-style-type: none"> <li>• Never use compressed air or a high pressure pump.</li> <li>• Do not exceed 4.12 kPa (0.042 kg/cm<sup>2</sup>, 0.6 psi) of pressure in the system.</li> </ul>		
<div style="border: 1px solid black; padding: 5px; width: fit-content; margin: 0 auto;"> <p style="text-align: center;">■ EVAP SYSTEM CLOSE ■ <input type="checkbox"/></p> <p style="text-align: center;">APPLY PRESSURE TO SERVICE PORT TO RANGE BELOW. DO NOT EXCEED 0.6psi.</p> <div style="text-align: center; margin: 5px 0;">  </div> <p style="text-align: center; font-weight: bold; font-size: 1.2em;">END</p> </div>		
SEF917U		
<p>4. Using EVAP leak detector, locate the EVAP leak. For the leak detector, refer to the instruction manual for more details. Refer to "EVAPORATIVE EMISSION LINE DRAWING", EC-28.</p>		
<p>Leak detector</p> 		
SEF200U		
<b>OK or NG</b>		
OK	▶	GO TO 8.
NG	▶	Repair or replace.



# DTC P0440 EVAPORATIVE EMISSION (EVAP) CONTROL SYSTEM (SMALL LEAK) (NEGATIVE PRESSURE)

Diagnostic Procedure (Cont'd)

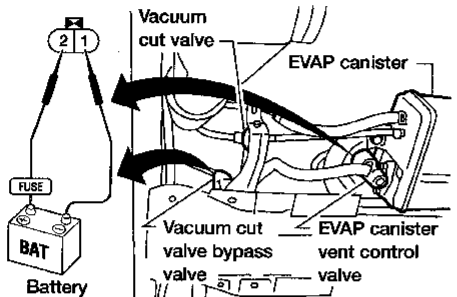
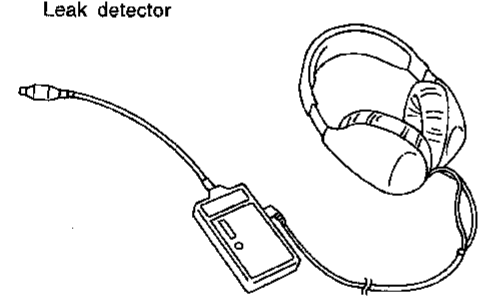
<b>7</b>	<b>CHECK FOR EVAP LEAK</b>
<p><b>⊗ Without CONSULT</b></p> <ol style="list-style-type: none"> <li>Turn ignition switch "OFF".</li> <li>Apply 12 volts DC to EVAP canister vent control valve. The valve will close. (Continue to apply 12 volts until the end of test.)</li> <li>Apply 12 volts DC to vacuum cut valve bypass valve. The valve will open. (Continue to apply 12V until the end of test.)</li> </ol>	
 <p style="text-align: right;">AEC632A</p>	
<ol style="list-style-type: none"> <li>Pressurize the EVAP line using pressure pump with 1.3 to 2.7 kPa (10 to 20 mmHg, 0.39 to 0.79 inHg), then remove pump and EVAP service port adapter.</li> </ol> <p><b>NOTE:</b></p> <ul style="list-style-type: none"> <li>Never use compressed air or a high pressure pump.</li> <li>Do not exceed 4.12 kPa (0.042 kg/cm<sup>2</sup>, 0.6 psi) of pressure in the system.</li> </ul> <ol style="list-style-type: none"> <li>Using EVAP leak detector, locate the EVAP leak. For the leak detector, refer to the instruction manual for more details. Refer to "EVAPORATIVE EMISSION LINE DRAWING", EC-28.</li> </ol>	
 <p style="text-align: right;">SEF200U</p>	
<b>OK or NG</b>	
OK	▶ GO TO 8.
NG	▶ Repair or replace.

<b>8</b>	<b>CHECK WATER SEPARATOR</b>
Refer to "Component Inspection", EC-413.	
<b>OK or NG</b>	
OK	▶ GO TO 9.
NG	▶ Replace water separator.

<b>9</b>	<b>CHECK EVAP CANISTER VENT CONTROL VALVE, O-RING AND CIRCUIT</b>
Refer to "DTC Confirmation Procedure", EC-316.	
<b>OK or NG</b>	
OK	▶ GO TO 10.
NG	▶ Repair or replace EVAP canister vent control valve and O-ring or harness/connector.

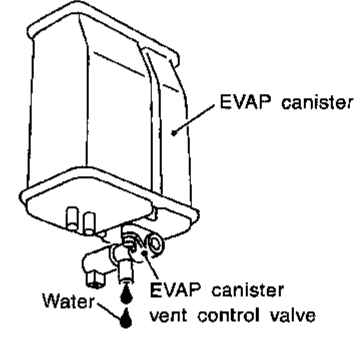
<b>10</b>	<b>CHECK IF EVAP CANISTER SATURATED WITH WATER</b>
<ol style="list-style-type: none"> <li>Remove EVAP canister with EVAP canister vent control valve attached.</li> <li>Check if water will drain from the EVAP canister.</li> </ol>	
 <p style="text-align: right;">SEF596U</p>	
<b>Yes or No</b>	
Yes	▶ GO TO 11.
No (With CONSULT)	▶ GO TO 13.
No (Without CONSULT)	▶ GO TO 14.

<b>11</b>	<b>CHECK EVAP CANISTER</b>
Weigh the EVAP canister with the EVAP canister vent control valve attached.	
The weight should be less than 1.8 kg (4.0 lb).	
<b>OK or NG</b>	
OK (With CONSULT)	▶ GO TO 13.
OK (Without CONSULT)	▶ GO TO 14.
NG	▶ GO TO 12.

<b>12</b>	<b>DETECT MALFUNCTIONING PART</b>
Check the following.	
<ul style="list-style-type: none"> <li>EVAP canister for damage</li> <li>EVAP hose between EVAP canister and water separator for clogging or poor connection</li> </ul>	
▶ Repair hose or replace EVAP canister.	

GI  
MA  
EM  
LC  
EC  
FE  
CL  
MT  
AT  
TF  
PD  
FA  
RA  
BR  
ST  
RS  
BT  
HA  
EL  
IDX

# DTC P0440 EVAPORATIVE EMISSION (EVAP) CONTROL SYSTEM (SMALL LEAK) (NEGATIVE PRESSURE)

Diagnostic Procedure (Cont'd)

<b>13</b>	<b>CHECK EVAP CANISTER PURGE VOLUME CONTROL SOLENOID VALVE OPERATION</b>																		
<p><b>Ⓜ With CONSULT</b></p> <ol style="list-style-type: none"> <li>1. Disconnect vacuum hose to EVAP canister purge volume control solenoid valve at EVAP service port.</li> <li>2. Start engine.</li> <li>3. Perform "PURG VOL CONT/V" in "ACTIVE TEST" mode.</li> <li>4. Touch "Qu" on CONSULT screen to increase "PURG VOL CONT/V" opening to 100.0%.</li> <li>5. Check vacuum hose for vacuum when revving engine up to 2,000 rpm.</li> </ol>																			
<table border="1" style="margin: auto; border-collapse: collapse;"> <tr> <td colspan="2" style="text-align: center;"><b>■ ACTIVE TEST ■</b></td> </tr> <tr> <td style="padding: 2px;">PURG VOL CONT/V</td> <td style="padding: 2px;">100.0%</td> </tr> <tr> <td colspan="2" style="text-align: center;">----- MONITOR -----</td> </tr> <tr> <td style="padding: 2px;">CMPS•RPM(REF)</td> <td style="padding: 2px;">2187rpm</td> </tr> <tr> <td style="padding: 2px;">FR O2 MNTR-B2</td> <td style="padding: 2px;">RICH</td> </tr> <tr> <td style="padding: 2px;">FR O2 MNTR-B1</td> <td style="padding: 2px;">RICH</td> </tr> <tr> <td style="padding: 2px;">A/F ALPHA-B2</td> <td style="padding: 2px;">100%</td> </tr> <tr> <td style="padding: 2px;">A/F ALPHA-B1</td> <td style="padding: 2px;">100%</td> </tr> <tr> <td style="padding: 2px;">THRTL POS SEN</td> <td style="padding: 2px;">0.64V</td> </tr> </table>		<b>■ ACTIVE TEST ■</b>		PURG VOL CONT/V	100.0%	----- MONITOR -----		CMPS•RPM(REF)	2187rpm	FR O2 MNTR-B2	RICH	FR O2 MNTR-B1	RICH	A/F ALPHA-B2	100%	A/F ALPHA-B1	100%	THRTL POS SEN	0.64V
<b>■ ACTIVE TEST ■</b>																			
PURG VOL CONT/V	100.0%																		
----- MONITOR -----																			
CMPS•RPM(REF)	2187rpm																		
FR O2 MNTR-B2	RICH																		
FR O2 MNTR-B1	RICH																		
A/F ALPHA-B2	100%																		
A/F ALPHA-B1	100%																		
THRTL POS SEN	0.64V																		
<table style="margin: auto;"> <tr> <td style="border: 1px solid black; padding: 2px;">Qu</td> <td style="border: 1px solid black; padding: 2px;">UP</td> <td style="border: 1px solid black; padding: 2px;">DWN</td> <td style="border: 1px solid black; padding: 2px;">Qd</td> </tr> </table>		Qu	UP	DWN	Qd														
Qu	UP	DWN	Qd																
<p>Vacuum should exist. <span style="float: right;">AEC912A</span></p> <p><b>OK or NG</b></p>																			
OK	▶ GO TO 17.																		
NG	▶ GO TO 15.																		

<b>14</b>	<b>CHECK EVAP CANISTER PURGE VOLUME CONTROL SOLENOID VALVE OPERATION</b>
<p><b>ⓧ Without CONSULT</b></p> <ol style="list-style-type: none"> <li>1. Start engine and warm it up to normal operating temperature.</li> <li>2. Stop engine.</li> <li>3. Disconnect vacuum hose to EVAP canister purge volume control solenoid valve at EVAP service port.</li> <li>4. Start engine and let it idle for at least 80 seconds.</li> <li>5. Check vacuum hose for vacuum when revving engine up to 2,000 rpm.</li> </ol> <p>Vacuum should exist.</p> <p style="text-align: center;"><b>OK or NG</b></p>	
OK	▶ GO TO 17.
NG	▶ GO TO 15.

<b>15</b>	<b>CHECK VACUUM HOSE</b>
<p>Check vacuum hoses for clogging or disconnection. Refer to "Vacuum Hose Drawing", EC-18.</p> <p style="text-align: center;"><b>OK or NG</b></p>	
OK	▶ GO TO 16.
NG	▶ Repair or reconnect the hose.

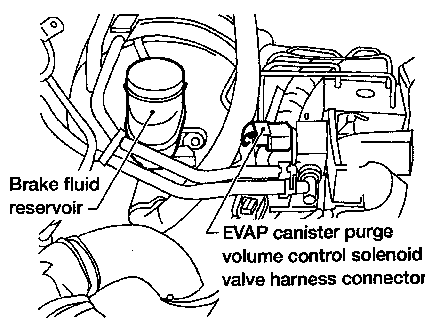
<b>16</b>	<b>CHECK EVAP CANISTER PURGE VOLUME CONTROL SOLENOID VALVE</b>
<p>Refer to "Component Inspection", EC-315.</p>	
 <p style="text-align: right;">AEC652A</p>	
<b>OK or NG</b>	
OK	▶ GO TO 17.
NG	▶ Replace EVAP canister purge volume control solenoid valve.

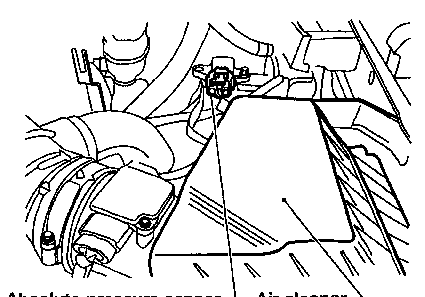
<b>17</b>	<b>CHECK ABSOLUTE PRESSURE SENSOR</b>
<p>Refer to "Component Inspection", EC-138.</p>	
 <p style="text-align: right;">AEC642A</p>	
<b>OK or NG</b>	
OK	▶ GO TO 18.
NG	▶ Replace absolute pressure sensor.

# DTC P0440 EVAPORATIVE EMISSION (EVAP) CONTROL SYSTEM (SMALL LEAK) (NEGATIVE PRESSURE)

Diagnostic Procedure (Cont'd)

<b>18</b>	<b>CHECK MAP/BARO SWITCH SOLENOID VALVE AND CIRCUIT</b>
Refer to "Component Inspection", EC-363.	
<b>OK or NG</b>	
OK	▶ GO TO 19.
NG	▶ Replace MAP/BARO switch solenoid valve.

<b>20</b>	<b>CHECK EVAP CONTROL SYSTEM PRESSURE SENSOR</b>
Refer to "Component Inspection", EC-328.	
<b>OK or NG</b>	
OK	▶ GO TO 21.
NG	▶ Replace EVAP control system pressure sensor.

<b>19</b>	<b>CHECK TANK FUEL TEMPERATURE SENSOR</b>
Refer to "Component Inspection", EC-265.	
<b>OK or NG</b>	
OK	▶ GO TO 20.
NG	▶ Replace tank fuel temperature sensor.

<b>21</b>	<b>CHECK EVAP PURGE LINE</b>
Check EVAP purge line (pipe, rubber tube, fuel tank and EVAP canister) for cracks or improper connection. Refer to "Evaporative Emission System", EC-24.	
<b>OK or NG</b>	
OK	▶ GO TO 22.
NG	▶ Repair or reconnect the hose.

<b>22</b>	<b>CLEAN EVAP PURGE LINE</b>
Clean EVAP purge line (pipe and rubber tube) using air blower.	
▶ GO TO 23.	

<b>23</b>	<b>CHECK INTERMITTENT INCIDENT</b>
Refer to "TROUBLE DIAGNOSIS FOR INTERMITTENT INCIDENT", EC-115.	
▶ INSPECTION END	

GI  
MA  
EM  
LC  
EC  
FE  
CL  
MT  
AT  
TF  
PD  
FA  
RA  
BR  
ST  
RS  
BT  
HA  
EL  
IDX

# DTC P0443 EVAPORATIVE EMISSION (EVAP) CANISTER PURGE VOLUME CONTROL SOLENOID VALVE (CIRCUIT)

Description

## Description SYSTEM DESCRIPTION

NEEC0214

NEEC0214S01

Sensor	Input Signal to ECM	ECM function	Actuator
Camshaft position sensor	Engine speed	EVAP can- ister purge flow control	EVAP canister purge volume control solenoid valve
Mass air flow sensor	Amount of intake air		
Engine coolant temperature sensor	Engine coolant temperature		
Ignition switch	Start signal		
Throttle position sensor	Throttle position		
Throttle position switch	Closed throttle position		
Front heated oxygen sensors	Density of oxygen in exhaust gas (Mixture ratio feedback signal)		
Tank fuel temperature sensor	Fuel temperature in fuel tank		
Vehicle speed sensor	Vehicle speed		

This system controls flow rate of fuel vapor from the EVAP canister. The opening of the vapor by-pass passage in the EVAP canister purge volume control solenoid valve changes to control the flow rate. The EVAP canister purge volume control solenoid valve repeats ON/OFF operation according to the signal sent from the ECM. The opening of the valve varies for optimum engine control. The optimum value stored in the ECM is determined by considering various engine conditions. When the engine is operating, the flow rate of fuel vapor from the EVAP canister is regulated as the air flow changes.

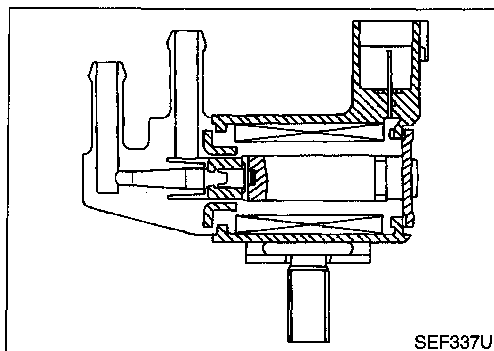

### COMPONENT DESCRIPTION

NEEC0214S02

The EVAP canister purge volume control solenoid valve uses a ON/OFF duty to control the flow rate of fuel vapor from the EVAP canister. The EVAP canister purge volume control solenoid valve is moved by ON/OFF pulses from the ECM. The longer the ON pulse, the greater the amount of fuel vapor that will flow through the valve.

### CONSULT Reference Value in Data Monitor Mode

NEEC0215

Specification data are reference values.

MONITOR ITEM	CONDITION	SPECIFICATION
PURG VOL C/V	<ul style="list-style-type: none"> <li>• Engine: After warming up</li> <li>• Air conditioner switch "OFF"</li> <li>• Shift lever: "N"</li> <li>• No-load</li> </ul>	Idle (Vehicle stopped)
		2,000 rpm
		0%
		—

# DTC P0443 EVAPORATIVE EMISSION (EVAP) CANISTER PURGE VOLUME CONTROL SOLENOID VALVE (CIRCUIT)

*ECM Terminals and Reference Value*

## ECM Terminals and Reference Value

Specification data are reference values and are measured between each terminal and 32 (ECM ground). NEEC0216

TERMI-NAL NO.	WIRE COLOR	ITEM	CONDITION	DATA (DC Voltage)
4	OR/B	ECM relay (Self shut-off)	[Engine is running] [Ignition switch "OFF"] • For a few seconds after turning ignition switch "OFF"	0 - 1.5V
			[Ignition switch "OFF"] • A few seconds passed after turning ignition switch "OFF"	BATTERY VOLTAGE (11 - 14V)
5	R/Y	EVAP canister purge volume control solenoid valve	[Engine is running] • Idle speed	BATTERY VOLTAGE (11 - 14V)   <span style="float: right;"><small>SEF994U</small></span>
			[Engine is running] • Engine speed is 2,000 rpm (More than 100 seconds after starting engine)	BATTERY VOLTAGE (11 - 14V)   <span style="float: right;"><small>SEF995U</small></span>
67	B/P	Power supply for ECM	[Ignition switch "ON"]	BATTERY VOLTAGE (11 - 14V)
72	B/P			
117	B/P	Current return	[Engine is running] • Idle speed	BATTERY VOLTAGE (11 - 14V)

## On Board Diagnosis Logic

DTC No.	Malfunction is detected when ...	Check Items (Possible Cause)
P0443 1008	An improper voltage signal is sent to ECM through the valve.	<ul style="list-style-type: none"> <li>• Harness or connectors (The valve circuit is open or shorted.)</li> <li>• EVAP canister purge volume control solenoid valve</li> </ul>

3

☆ MONITOR    ☆ NO FAIL

CMPS•RPM(REF)      750 rpm

RECORD

SEF357VA

## DTC Confirmation Procedure

### NOTE:

If "DTC Confirmation Procedure" has been previously conducted, always turn ignition switch "OFF" and wait at least 5 seconds before conducting the next test.

### TESTING CONDITION:

**Before performing the following procedure, confirm battery voltage is more than 11V at idle.**

#### ③ With CONSULT

- 1) Turn ignition switch "ON".
- 2) Select "DATA MONITOR" mode with CONSULT.

# DTC P0443 EVAPORATIVE EMISSION (EVAP) CANISTER PURGE VOLUME CONTROL SOLENOID VALVE (CIRCUIT)

## DTC Confirmation Procedure (Cont'd)

---

- 3) Start engine and let it idle for at least 13 seconds.
- 4) If 1st trip DTC is detected, go to "Diagnostic Procedure", EC-314.

### **With GST**

- 1) Start engine and let it idle for at least 13 seconds.
- 2) Select "MODE 7" with GST.
- 3) If 1st trip DTC is detected, go to "Diagnostic Procedure", EC-314.

### **No Tools**

- 1) Start engine and let it idle for at least 13 seconds.
- 2) Turn ignition switch "OFF" and wait at least 5 seconds.
- 3) Turn ignition switch "ON" and perform "Diagnostic Test Mode II (Self-diagnostic results)" with ECM.
- 4) If 1st trip DTC is detected, go to "Diagnostic Procedure", EC-314.

# DTC P0443 EVAPORATIVE EMISSION (EVAP) CANISTER PURGE VOLUME CONTROL SOLENOID VALVE (CIRCUIT)

Wiring Diagram

## Wiring Diagram

NEEC0219

EC-PGC/V-01

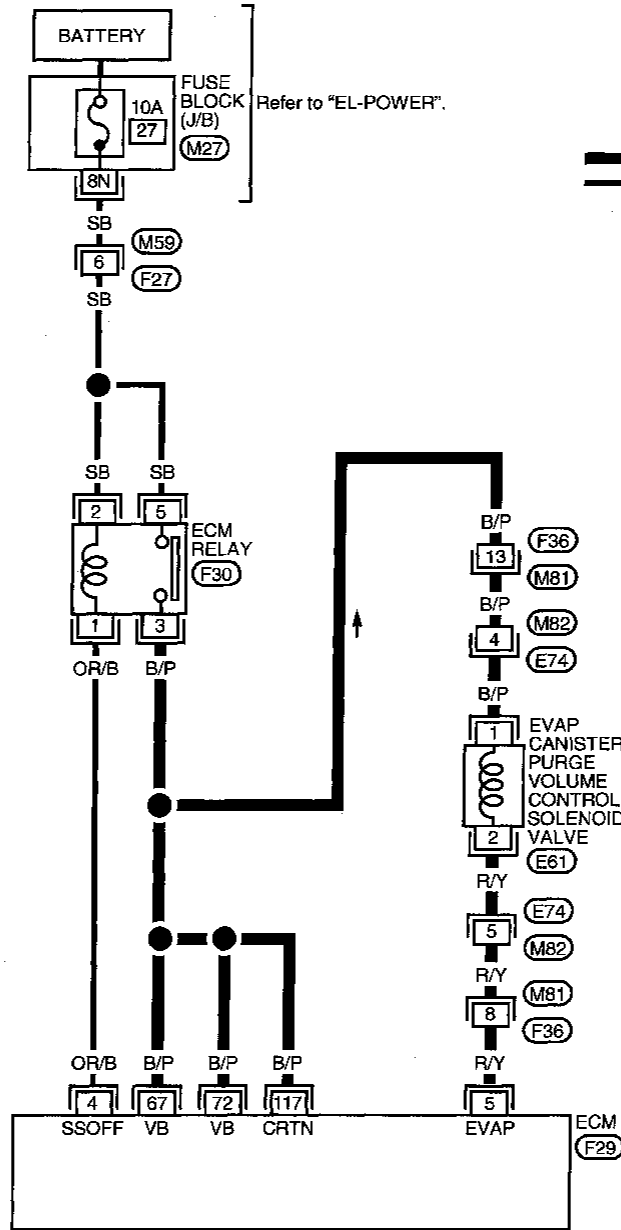

— : Detectable line for DTC  
 — : Non-detectable line for DTC

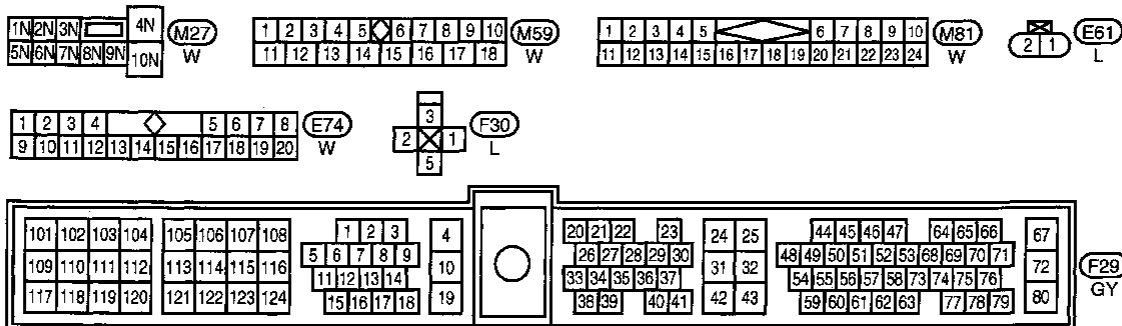

AEC743A

# DTC P0443 EVAPORATIVE EMISSION (EVAP) CANISTER PURGE VOLUME CONTROL SOLENOID VALVE (CIRCUIT)

Diagnostic Procedure

## Diagnostic Procedure

NEEC0220

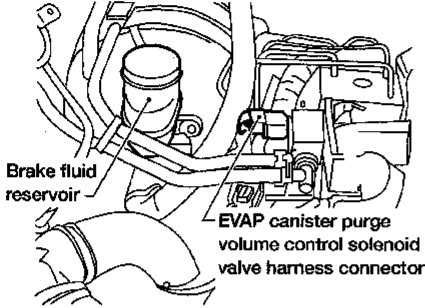
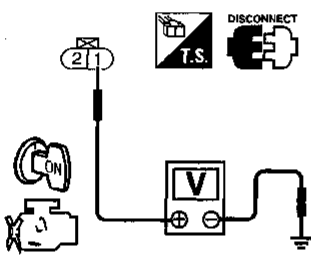
<b>1</b>	<b>CHECK POWER SUPPLY</b>
<ol style="list-style-type: none"> <li>Turn ignition switch "OFF".</li> <li>Disconnect EVAP canister purge volume control solenoid valve harness connector.</li> </ol>	
 <p>Brake fluid reservoir</p> <p>EVAP canister purge volume control solenoid valve harness connector</p>	
AEC652A	
<ol style="list-style-type: none"> <li>Turn ignition switch "ON".</li> <li>Check voltage between terminal 1 and ground with CONSULT or tester.</li> </ol>	
 <p style="text-align: center;">Voltage: Battery voltage</p>	
OK or NG	
OK	▶ GO TO 3.
NG	▶ GO TO 2.

<b>2</b>	<b>DETECT MALFUNCTIONING PART</b>
<p>Check the following.</p> <ul style="list-style-type: none"> <li>Harness connectors F36, M81</li> <li>Harness connectors M82, E74</li> <li>Harness for open or short between EVAP canister purge volume control solenoid valve and ECM relay</li> </ul>	
▶ Repair harness or connectors.	

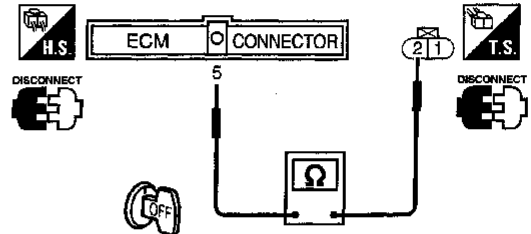
<b>3</b>	<b>CHECK OUTPUT SIGNAL CIRCUIT</b>
<ol style="list-style-type: none"> <li>Turn ignition switch "OFF".</li> <li>Disconnect ECM harness connector.</li> <li>Check harness continuity between ECM terminal 5 and terminal 2.</li> </ol>	
 <p style="text-align: center;">Continuity should exist.</p>	
SEF647W	
<ol style="list-style-type: none"> <li>Also check harness for short to ground and short to power.</li> </ol>	
OK or NG	
OK	▶ GO TO 5.
NG	▶ GO TO 4.

<b>4</b>	<b>DETECT MALFUNCTIONING PART</b>
<p>Check the following.</p> <ul style="list-style-type: none"> <li>Harness connectors E74, M82</li> <li>Harness connectors M81, F36</li> <li>Harness for open or short between EVAP canister purge volume control solenoid valve and ECM</li> </ul>	
▶ Repair open circuit or short to ground or short to power in harness or connectors.	

<b>5</b>	<b>CHECK EVAP CANISTER PURGE VOLUME CONTROL SOLENOID VALVE</b>
<p>Refer to "Component Inspection", EC-315.</p>	
OK or NG	
OK	▶ GO TO 6.
NG	▶ Replace EVAP canister purge volume control solenoid valve.

<b>6</b>	<b>CHECK INTERMITTENT INCIDENT</b>
<p>Refer to "TROUBLE DIAGNOSIS FOR INTERMITTENT INCIDENT", EC-115.</p>	
▶ INSPECTION END	



# DTC P0443 EVAPORATIVE EMISSION (EVAP) CANISTER PURGE VOLUME CONTROL SOLENOID VALVE (CIRCUIT)

Component Inspection

ACTIVE TEST

PURG VOL CONT/V 0.0%

---

===== MONITOR =====

CMPS•RPM(REF)	787rpm
FR O2 MNTR-B2	RICH
FR O2 MNTR-B1	RICH
A/F ALPHA-B2	100%
A/F ALPHA-B1	100%
THRTL POS SEN	0.44V

Qu
UP
DWN
Qd

SEF882U

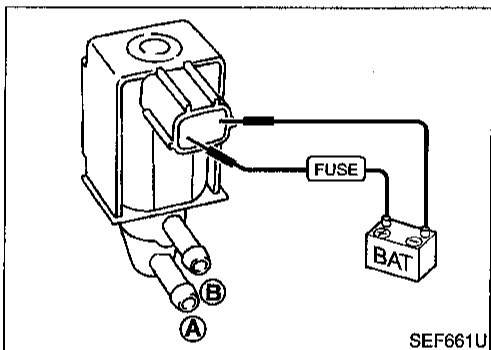
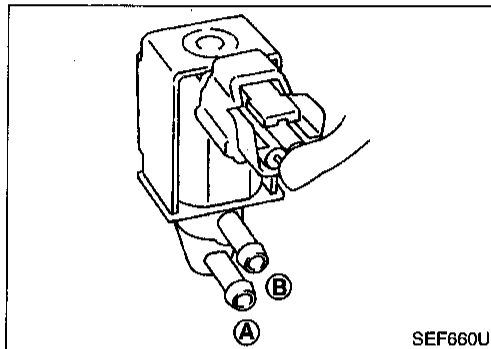

## Component Inspection

NEEC0221

### EVAP CANISTER PURGE VOLUME CONTROL SOLENOID VALVE

NEEC0221S01

#### Ⓜ With CONSULT

1. Start engine.
2. Perform "PURG VOL CONT/V" in "ACTIVE TEST" mode with CONSULT. Check that engine speed varies according to the valve opening.  
If OK, inspection end. If NG, go to following step.
3. Check air passage continuity.

Condition PURG VOL CONT/V value	Air passage continuity between A and B
100.0%	Yes
0.0%	No

If NG, replace the EVAP canister purge volume control solenoid valve.

#### ⓧ Without CONSULT

Check air passage continuity.

Condition	Air passage continuity between A and B
12V direct current supply between terminals	Yes
No supply	No

If NG or operation takes more than 1 second, replace solenoid valve.

GI  
MA  
EM  
LC  
EC  
FE  
CL  
MT  
AT  
TF  
PD  
FA  
RA  
BR  
ST  
RS  
BT  
HA  
EL  
IDX

# DTC P0446 EVAPORATIVE EMISSION (EVAP) CANISTER VENT CONTROL VALVE (CIRCUIT)

## Component Description

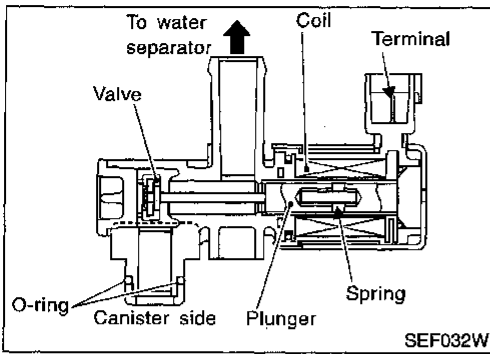

## Component Description

NEEC0222

The EVAP canister vent control valve is located on the EVAP canister and is used to seal the canister vent.

This solenoid valve responds to signals from the ECM. When the ECM sends an ON signal, the coil in the solenoid valve is energized. A plunger will then move to seal the canister vent. The ability to seal the vent is necessary for the on board diagnosis of other evaporative emission control system components.

This solenoid valve is used only for diagnosis, and usually remains opened.

When the vent is closed, under normal purge conditions, the evaporative emission control system is depressurized and allows "EVAP Control System (Small Leak)" diagnosis.

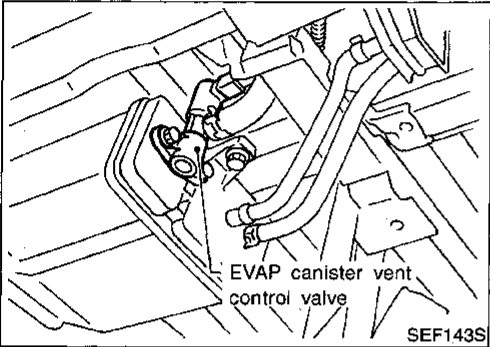

## CONSULT Reference Value in Data Monitor Mode

NEEC0223

Specification data are reference values.

MONITOR ITEM	CONDITION	SPECIFICATION
VENT CONT/V	• Ignition switch: ON	OFF

## ECM Terminals and Reference Value

NEEC0224

Specification data are reference values and are measured between each terminal and 32 (ECM ground).

TERMI-NAL NO.	WIRE COLOR	ITEM	CONDITION	DATA (DC Voltage)
108	R/G	EVAP canister vent control valve	[Ignition switch "ON"]	BATTERY VOLTAGE (11 - 14V)

## On Board Diagnosis Logic

NEEC0225

DTC No.	Malfunction is detected when ...	Check Items (Possible Cause)
P0446 0903	An improper voltage signal is sent to ECM through EVAP canister vent control valve.	<ul style="list-style-type: none"> <li>• Harness or connectors (The valve circuit is open or shorted.)</li> <li>• EVAP canister vent control valve</li> </ul>

## DTC Confirmation Procedure

NEEC0226

### NOTE:

If "DTC Confirmation Procedure" has been previously conducted, always turn ignition switch "OFF" and wait at least 5 seconds before conducting the next test.

### TESTING CONDITION:

Before performing the following procedure, confirm battery voltage is more than 11V at idle.

# DTC P0446 EVAPORATIVE EMISSION (EVAP) CANISTER VENT CONTROL VALVE (CIRCUIT)

DTC Confirmation Procedure (Cont'd)

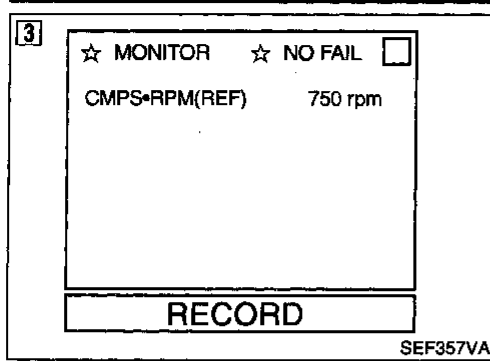

## ⑤ With CONSULT

- 1) Turn ignition switch "ON".
- 2) Select "DATA MONITOR" mode with CONSULT.
- 3) Start engine and wait at least 8 seconds.
- 4) If 1st trip DTC is detected, go to "Diagnostic Procedure", EC-319.

## ⑥ With GST

- 1) Start engine and wait at least 8 seconds.
- 2) Select "MODE 7" with GST.
- 3) If 1st trip DTC is detected, go to "Diagnostic Procedure", EC-319.

## ⑦ No Tools

- 1) Start engine and wait at least 8 seconds.
- 2) Turn ignition switch "OFF", wait at least 5 seconds and then turn "ON".
- 3) Perform "Diagnostic Test Mode II (Self-diagnostic results)" with ECM.
- 4) If 1st trip DTC is detected, go to "Diagnostic Procedure", EC-319.

GI

MA

EM

LC

EC

FE

CL

MT

AT

TF

PD

FA

RA

BR

ST

RS

BT

HA

EL

IDX

# DTC P0446 EVAPORATIVE EMISSION (EVAP) CANISTER VENT CONTROL VALVE (CIRCUIT)

Wiring Diagram

## Wiring Diagram

NEEC0228

### EC-VENT/V-01

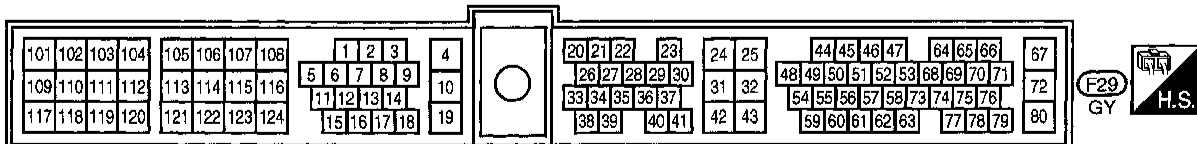
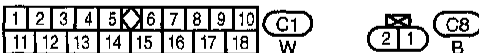
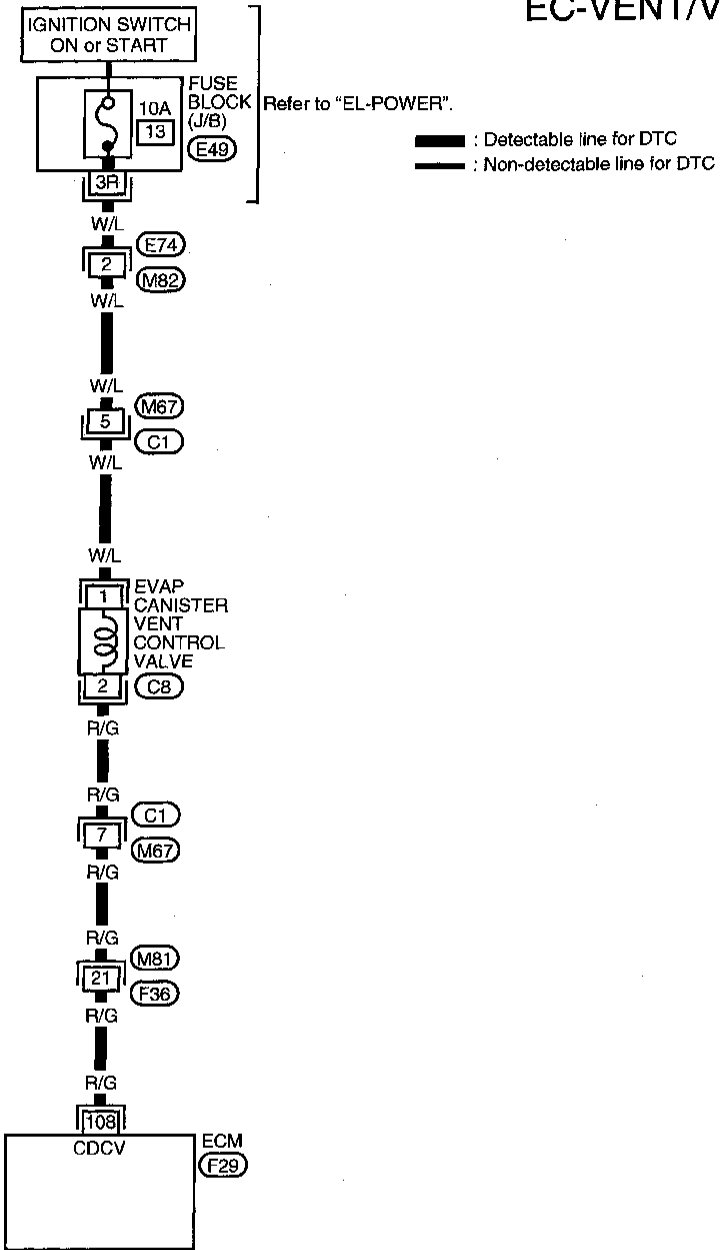

AEC744A

# DTC P0446 EVAPORATIVE EMISSION (EVAP) CANISTER VENT CONTROL VALVE (CIRCUIT)

Diagnostic Procedure

## Diagnostic Procedure

NEEC0229

<b>1</b>	<b>INSPECTION START</b>	
Do you have CONSULT?		
Yes or No		
Yes	▶	GO TO 2.
No	▶	GO TO 3.

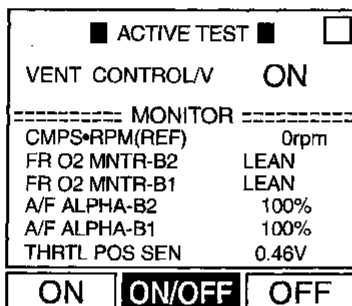
<b>2</b>	<b>CHECK EVAP CANISTER VENT CONTROL VALVE CIRCUIT</b>	
1. Turn ignition switch "OFF" and then turn "ON". 2. Select "VENT CONTROL/V" in "ACTIVE TEST" mode with CONSULT. 3. Touch "ON/OFF" on CONSULT screen.		
		
4. Check for operating sound of the valve. Clicking noise should be heard.		
OK or NG		
OK	▶	GO TO 7.
NG	▶	GO TO 3.

SEF883U

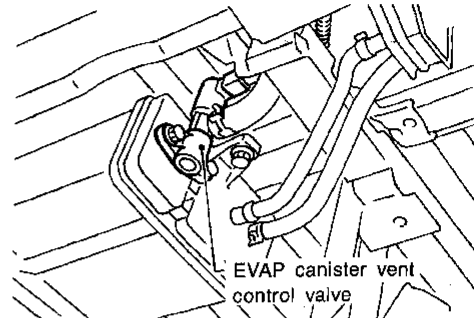
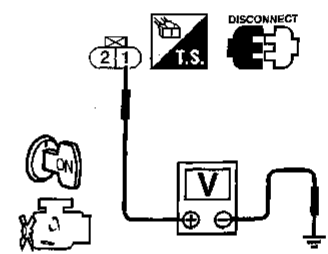
<b>3</b>	<b>CHECK POWER SUPPLY</b>	
1. Turn ignition switch "OFF". 2. Disconnect EVAP canister vent control valve harness connector.		
		
3. Turn ignition switch "ON". 4. Check voltage between terminal 1 and ground with CONSULT or tester.		
		
Voltage: Battery voltage		
OK or NG		
OK	▶	GO TO 5.
NG	▶	GO TO 4.

SEF143S

SEF648W

<b>4</b>	<b>DETECT MALFUNCTIONING PART</b>	
Check the following. <ul style="list-style-type: none"> <li>• Harness connectors E74, M82</li> <li>• Harness connectors M67, C1</li> <li>• Fuse block (J/B) connector E49</li> <li>• 10A fuse</li> <li>• Harness for open or short between EVAP canister vent control valve and fuse</li> </ul>		
▶		Repair harness or connectors.

GI  
MA  
EM  
LC  
EC  
FE  
CL  
MT  
AT  
TF  
PD  
FA  
RA  
BR  
ST  
RS  
BT  
HA  
EL  
IDX

# DTC P0446 EVAPORATIVE EMISSION (EVAP) CANISTER VENT CONTROL VALVE (CIRCUIT)

Diagnostic Procedure (Cont'd)

**5 CHECK OUTPUT SIGNAL CIRCUIT**

- Turn ignition switch "OFF".
- Disconnect ECM harness connector.
- Check harness continuity between ECM terminal 108 and terminal 2.

Continuity should exist.

- Also check harness for short to ground and short to power.

OK or NG	
OK	▶ GO TO 7.
NG	▶ GO TO 6.

**6 DETECT MALFUNCTIONING PART**

Check the following.

- Harness connectors C1, M67
- Harness connectors M81, F36
- Harness for open or short between EVAP canister vent control valve and ECM

▶	Repair open circuit or short to ground or short to power in harness or connectors.
---	--

**7 CHECK EVAP CANISTER VENT CONTROL VALVE**

Refer to "Component Inspection" EC-320.

OK or NG	
OK	▶ GO TO 8.
NG	▶ Replace EVAP canister vent control valve.

**8 CHECK INTERMITTENT INCIDENT**

Refer to "TROUBLE DIAGNOSIS FOR INTERMITTENT INCIDENT", EC-115.

▶	INSPECTION END
---	----------------

## Component Inspection EVAP CANISTER VENT CONTROL VALVE

NEEC0230  
NEEC0230501

Check air passage continuity.

ⓐ With CONSULT

Perform "VENT CONTROL/V" in "ACTIVE TEST" mode.

Condition VENT CONTROL/V	Air passage continuity between A and B
ON	No
OFF	Yes

ⓑ Without CONSULT

Condition	Air passage continuity between A and B
12V direct current supply between terminals 1 and 2	No
No supply	Yes

# DTC P0446 EVAPORATIVE EMISSION (EVAP) CANISTER VENT CONTROL VALVE (CIRCUIT)

Component Inspection (Cont'd)

If NG or operation takes more than 1 second, clean valve using air blower or replace as necessary.

**If portion B is rusted, replace EVAP canister vent control valve.**

**Make sure new O-ring is installed properly.**

GI

MA

EM

LC

**EC**

FE

CL

MT

AT

TF

PD

FA

RA

BR

ST

RS

BT

HA

EL

IDX

# DTC P0450 EVAPORATIVE EMISSION (EVAP) CONTROL SYSTEM PRESSURE SENSOR

## Component Description

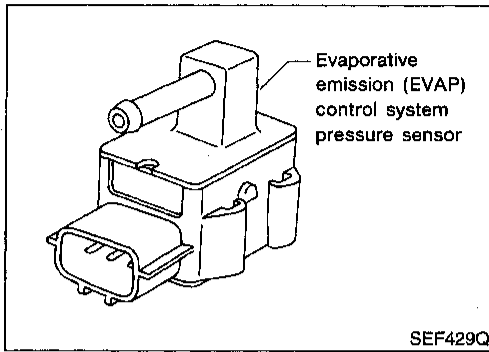

## Component Description

NEEC0231

The EVAP control system pressure sensor detects pressure in the purge line. The sensor output voltage to the ECM increases as pressure increases. The EVAP control system pressure sensor is not used to control the engine system. It is used only for on board diagnosis.

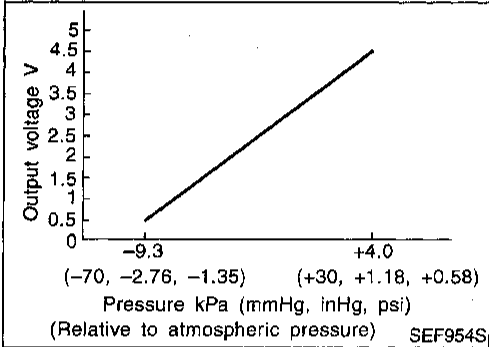

## CONSULT Reference Value in Data Monitor Mode

NEEC0232

Specification data are reference values.

MONITOR ITEM	CONDITION	SPECIFICATION
EVAP SYS PRES	• Ignition switch: ON	Approx. 3.4V

## ECM Terminals and Reference Value

NEEC0233

Specification data are reference values and are measured between each terminal and 32 (ECM ground).

TERMI- NAL NO.	WIRE COLOR	ITEM	CONDITION	DATA (DC Voltage)
42	B/W	Sensors' power supply	[Ignition switch "ON"]	Approximately 5V
43	BR	Sensors' ground	[Engine is running] • Warm-up condition • Idle speed	Approximately 0V
62	Y	EVAP control system pres- sure sensor	[Ignition switch "ON"]	Approximately 3.4V



# DTC P0450 EVAPORATIVE EMISSION (EVAP) CONTROL SYSTEM PRESSURE SENSOR

On Board Diagnosis Logic

## On Board Diagnosis Logic

NEEC0234

DTC No.	Malfunction is detected when ...	Check Items (Possible Cause)
P0450 0704	<ul style="list-style-type: none"> <li>An improper voltage signal from EVAP control system pressure sensor is sent to ECM.</li> </ul>	<ul style="list-style-type: none"> <li>Harness or connectors (The EVAP control system pressure sensor circuit is open or shorted.)</li> <li>Rubber hose to EVAP control system pressure sensor is clogged, vent, kinked, disconnected or improper connection.</li> <li>EVAP control system pressure sensor</li> <li>EVAP canister vent control valve</li> <li>EVAP canister purge volume control solenoid valve</li> <li>EVAP canister</li> <li>Rubber hose from EVAP canister vent control valve to water separator</li> </ul>

## DTC Confirmation Procedure

NEEC0295

### NOTE:

If "DTC Confirmation Procedure" has been previously conducted, always turn ignition switch "OFF" and wait at least 5 seconds before conducting the next test.

### TESTING CONDITION:

Always perform test at a temperature of 5°C (41°F) or more.

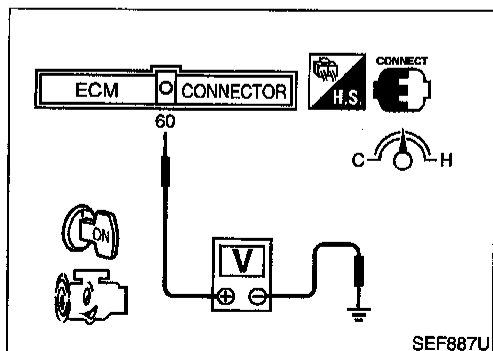
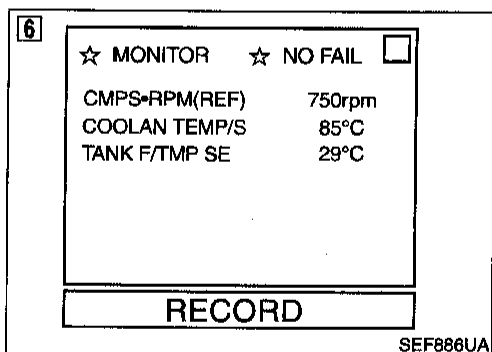

### ④ With CONSULT

- 1) Start engine and warm it up to normal operating temperature.
- 2) Turn ignition switch "OFF" and wait at least 5 seconds.
- 3) Turn ignition switch "ON".
- 4) Select "DATA MONITOR" mode with CONSULT.
- 5) Make sure that "TANK F/TEMP SE" is more than 0°C (32°F).
- 6) Start engine and wait at least 20 seconds.
- 7) If 1st trip DTC is detected, go to "Diagnostic Procedure", EC-326.

### ④ With GST

- 1) Start engine and warm it up to normal operating temperature.
- 2) Check that voltage between ECM terminal 60 (Tank fuel temperature sensor signal) and ground is less than 4.2V.
- 3) Turn ignition switch "OFF" and wait at least 5 seconds.
- 4) Start engine and wait at least 20 seconds.
- 5) Select "MODE 7" with GST.
- 6) If 1st trip DTC is detected, go to "Diagnostic Procedure", EC-326.

### ④ No Tools

- 1) Start engine and warm it up to normal operating temperature.

## **DTC P0450 EVAPORATIVE EMISSION (EVAP) CONTROL SYSTEM PRESSURE SENSOR**

### *DTC Confirmation Procedure (Cont'd)*

---

- 2) Check that voltage between ECM terminal 60 (Tank fuel temperature sensor signal) and ground is less than 4.2V.
- 3) Turn ignition switch "OFF" and wait at least 5 seconds.
- 4) Start engine and wait at least 20 seconds.
- 5) Turn ignition switch "OFF", wait at least 5 seconds and then turn "ON".
- 6) Perform "Diagnostic Test Mode II (Self-diagnostic results)" with ECM.
- 7) If 1st trip DTC is detected, go to "Diagnostic Procedure", EC-326.

# DTC P0450 EVAPORATIVE EMISSION (EVAP) CONTROL SYSTEM PRESSURE SENSOR

Wiring Diagram

## Wiring Diagram

NEEC0236

EC-PRE/SE-01

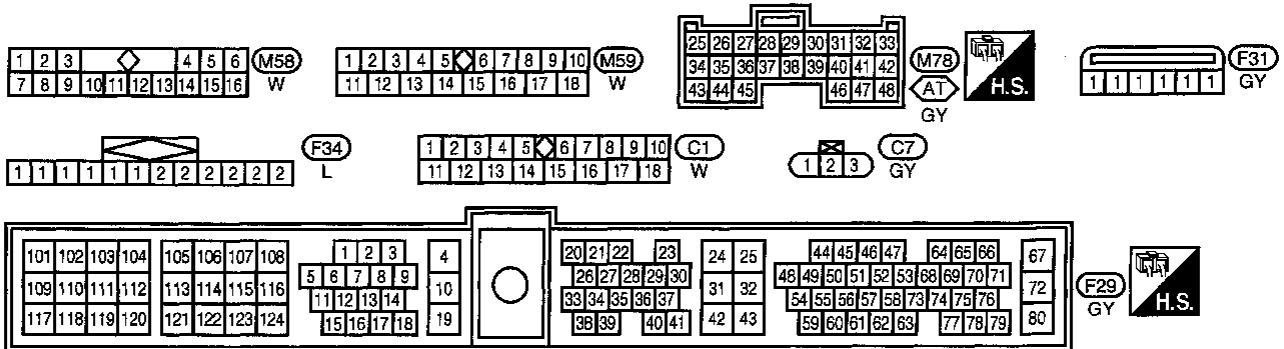
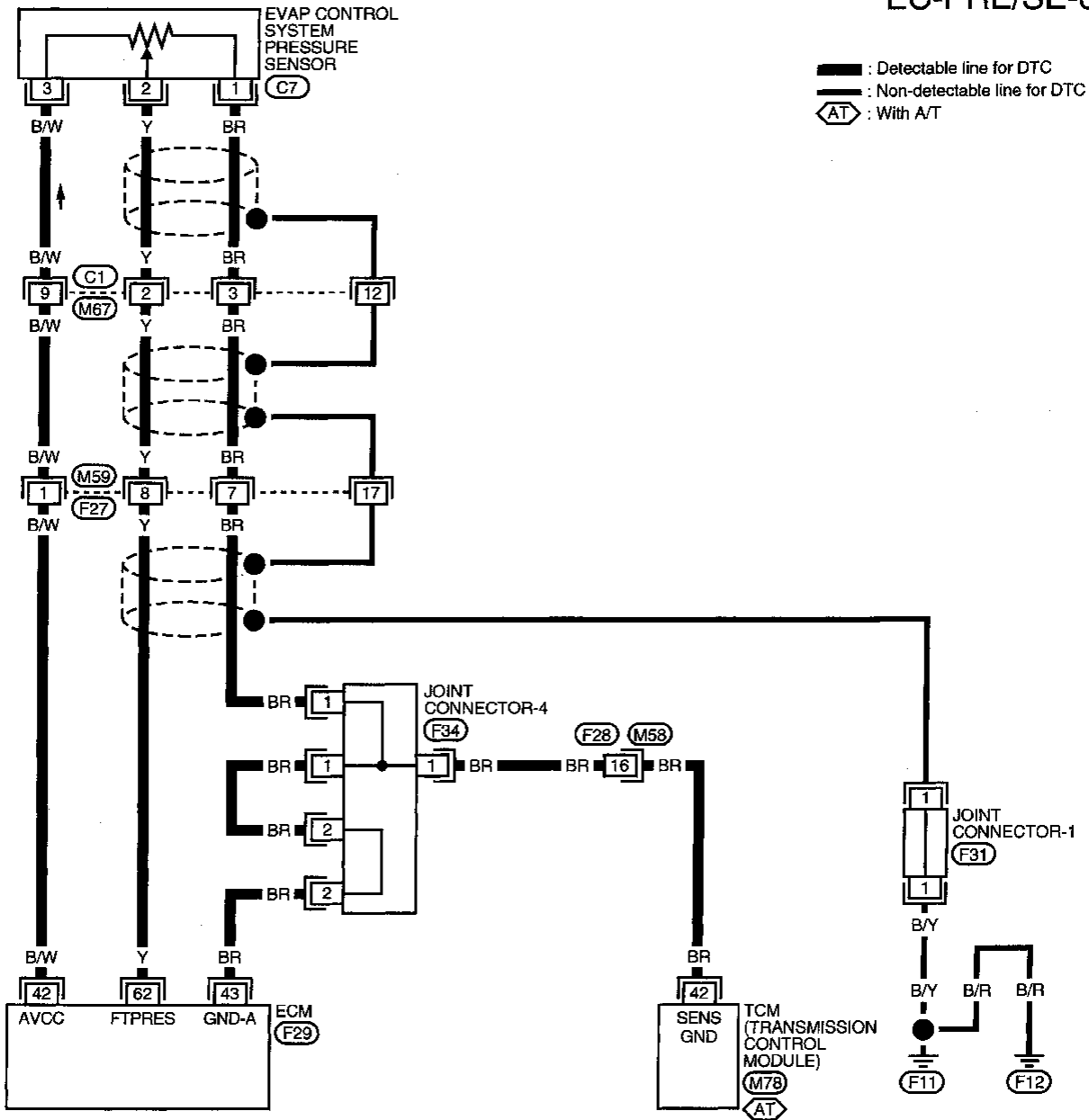

AEC745A

# DTC P0450 EVAPORATIVE EMISSION (EVAP) CONTROL SYSTEM PRESSURE SENSOR

Diagnostic Procedure

## Diagnostic Procedure

NEEC0237

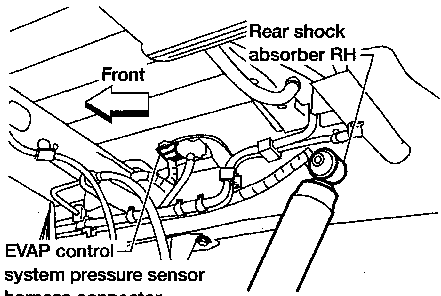
<b>1</b>	<b>CHECK RUBBER TUBE</b>
<ol style="list-style-type: none"> <li>Turn ignition switch "OFF".</li> <li>Check rubber tube connected to the sensor for clogging, vent, kink, disconnection or improper connection.</li> </ol>	
 <p>EVAP control system pressure sensor harness connector</p> <p style="text-align: right;">AEC651A</p>	
<b>OK or NG</b>	
OK	▶ GO TO 2.
NG	▶ Reconnect, repair or replace.

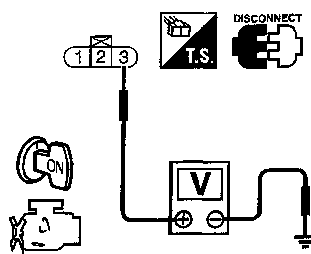
<b>4</b>	<b>CHECK POWER SUPPLY</b>
<ol style="list-style-type: none"> <li>Turn ignition switch "ON".</li> <li>Check voltage between terminal 3 and ground with CONSULT or tester.</li> </ol>	
 <p style="text-align: center;"><b>Voltage: Approximately 5V</b></p> <p style="text-align: center;"><b>OK or NG</b></p> <p style="text-align: right;">SEF889U</p>	
OK	▶ GO TO 6.
NG	▶ GO TO 5.

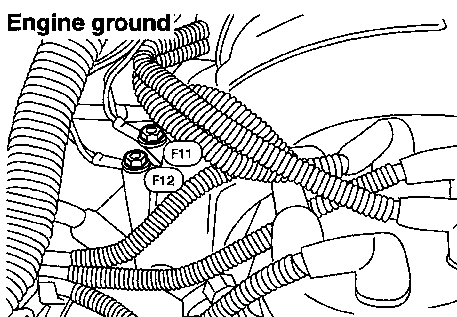
<b>2</b>	<b>RETIGHTEN GROUND SCREWS</b>
<ol style="list-style-type: none"> <li>Loosen and retighten engine ground screws.</li> </ol>	
 <p style="text-align: right;">AEC640A</p>	
▶ GO TO 3.	

<b>5</b>	<b>DETECT MALFUNCTIONING PART</b>
<p>Check the following.</p> <ul style="list-style-type: none"> <li>Harness connectors C1, M67</li> <li>Harness connectors M59, F27</li> <li>Harness for open or short between EVAP control system pressure sensor and ECM</li> </ul>	
▶ Repair harness or connectors.	

<b>3</b>	<b>CHECK CONNECTOR</b>
<ol style="list-style-type: none"> <li>Disconnect EVAP control system pressure sensor harness connector.</li> <li>Check sensor harness connector for water. <b>Water should not exist.</b></li> </ol>	
<b>OK or NG</b>	
OK	▶ GO TO 4.
NG	▶ Repair or replace harness connector.

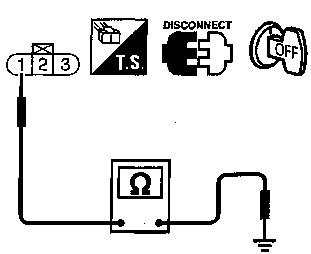
<b>6</b>	<b>CHECK GROUND CIRCUIT</b>
<ol style="list-style-type: none"> <li>Turn ignition switch "OFF".</li> <li>Check harness continuity between terminal 1 and engine ground.</li> </ol>	
 <p style="text-align: right;">SEF890U</p>	
<b>Continuity should exist.</b>	
<ol style="list-style-type: none"> <li>Also check harness for short to ground and short to power.</li> </ol>	
<b>OK or NG</b>	
OK	▶ GO TO 8.
NG	▶ GO TO 7.

# DTC P0450 EVAPORATIVE EMISSION (EVAP) CONTROL SYSTEM PRESSURE SENSOR

Diagnostic Procedure (Cont'd)

<b>7</b>	<b>DETECT MALFUNCTIONING PART</b>
<p>Check the following.</p> <ul style="list-style-type: none"> <li>• Harness connectors C1, M67</li> <li>• Harness connectors M59, F27</li> <li>• Harness connectors F28, M58</li> <li>• Joint connector-4</li> <li>• Harness for open or short between EVAP control system pressure sensor and ECM</li> <li>• Harness for open or short between EVAP control system pressure sensor and TCM (Transmission Control Module)</li> </ul>	
▶ Repair open circuit or short to ground or short to power in harness or connectors.	

<b>8</b>	<b>CHECK INPUT SIGNAL CIRCUIT</b>
<ol style="list-style-type: none"> <li>1. Disconnect ECM harness connector.</li> <li>2. Check harness continuity between ECM terminal 62 and terminal 2.</li> </ol>	
<p>Continuity should exist.</p>	
<ol style="list-style-type: none"> <li>3. Also check harness for short to ground and short to power.</li> </ol>	
<b>OK or NG</b>	
OK	▶ GO TO 10.
NG	▶ GO TO 9.

<b>9</b>	<b>DETECT MALFUNCTIONING PART</b>
<p>Check the following.</p> <ul style="list-style-type: none"> <li>• Harness connectors C1, M67</li> <li>• Harness connectors M59, F27</li> <li>• Harness for open or short between ECM and EVAP control system pressure sensor</li> </ul>	
▶ Repair open circuit or short to ground or short to power in harness or connectors.	

<b>10</b>	<b>CHECK EVAP CANISTER PURGE VOLUME CONTROL SOLENOID VALVE</b>
Refer to "Component Inspection", EC-315.	
<b>OK or NG</b>	
OK	▶ GO TO 11.
NG	▶ Replace EVAP canister purge volume control solenoid valve.

<b>11</b>	<b>CHECK EVAP CANISTER VENT CONTROL VALVE</b>
Refer to "Component Inspection", EC-320.	
<b>OK or NG</b>	
OK	▶ GO TO 12.
NG	▶ Replace EVAP canister vent control valve.

<b>12</b>	<b>CHECK EVAP CONTROL SYSTEM PRESSURE SENSOR</b>
Refer to "Component Inspection", EC-328.	
<b>OK or NG</b>	
OK	▶ GO TO 13.
NG	▶ Replace EVAP control system pressure sensor.

<b>13</b>	<b>CHECK RUBBER TUBE</b>
<ol style="list-style-type: none"> <li>1. Check obstructed water separator and rubber tube connected to EVAP canister vent control valve. For water separator, refer to EC-413.</li> <li>2. Clean the rubber tube using air blower.</li> </ol>	
<b>OK or NG</b>	
OK	▶ GO TO 14.
NG	▶ Clean, repair or replace rubber tube and/or water separator.

<b>14</b>	<b>CHECK IF EVAP CANISTER SATURATED WITH WATER</b>
<ol style="list-style-type: none"> <li>1. Remove EVAP canister with EVAP canister vent control valve attached.</li> <li>2. Check if water will drain from the EVAP canister.</li> </ol>	
<b>Yes or No</b>	
Yes	▶ GO TO 15.
No	▶ GO TO 17.

GI  
MA  
EM  
LC  
EC  
FE  
CL  
MT  
AT  
TF  
PD  
FA  
RA  
BR  
ST  
RS  
BT  
HA  
EL  
IDX

# DTC P0450 EVAPORATIVE EMISSION (EVAP) CONTROL SYSTEM PRESSURE SENSOR

Diagnostic Procedure (Cont'd)

<b>15</b>	<b>CHECK EVAP CANISTER</b>
Weigh the EVAP canister with the EVAP canister vent control valve attached. The weight should be less than 1.8 kg (4.0 lb).	
<b>OK or NG</b>	
OK	▶ GO TO 17.
NG	▶ GO TO 16.

<b>16</b>	<b>DETECT MALFUNCTIONING PART</b>
Check the following.	
<ul style="list-style-type: none"> <li>• EVAP canister for damage</li> <li>• EVAP hose between EVAP canister and water separator for clogging or poor connection.</li> </ul>	
▶ Repair hose or replace EVAP canister.	

<b>17</b>	<b>CHECK SHIELD CIRCUIT</b>
<ol style="list-style-type: none"> <li>1. Reconnect harness connectors disconnected.</li> <li>2. Disconnect harness connectors C1, M67.</li> <li>3. Check harness continuity between harness connector M67 and engine ground. <b>Continuity should exist.</b></li> <li>4. Also check harness for short to ground and short to power.</li> </ol>	
<b>OK or NG</b>	
OK	▶ GO TO 19.
NG	▶ GO TO 18.

<b>18</b>	<b>DETECT MALFUNCTIONING PART</b>
Check the following.	
<ul style="list-style-type: none"> <li>• Harness connectors C1, M67</li> <li>• Harness connectors M59, F27</li> <li>• Joint connector-1</li> <li>• Harness for open or short between harness connector M67 and engine ground</li> </ul>	
▶ Repair open circuit or short to ground or short to power in harness or connectors.	

<b>19</b>	<b>CHECK INTERMITTENT INCIDENT</b>
Refer to "TROUBLE DIAGNOSIS FOR INTERMITTENT INCIDENT", EC-115.	
▶ <b>INSPECTION END</b>	

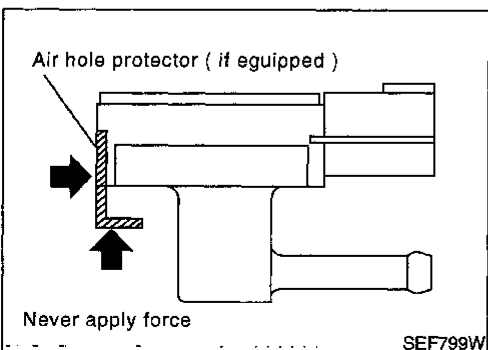
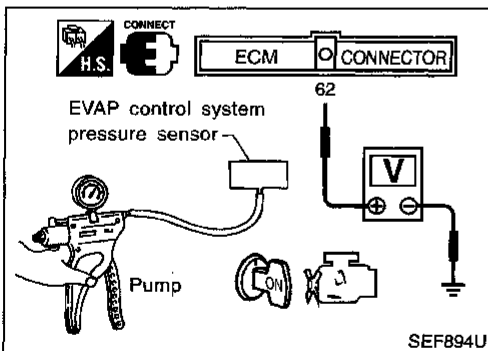

## Component Inspection

### EVAP CONTROL SYSTEM PRESSURE SENSOR

NEEC0238

NEEC0238S01

1. Remove EVAP control system pressure sensor with its harness connector connected.
2. Remove hose from EVAP control system pressure sensor.
3. Turn ignition switch "ON".
4. Use pump to apply vacuum and pressure to EVAP control system pressure sensor as shown in figure.
5. Check input voltage between ECM terminal 62 and ground.

Pressure (Relative to atmospheric pressure)	Voltage (V)
0 kPa (0 mmHg, 0 inHg)	3.0 - 3.6
-9.3 kPa (-70 mmHg, -2.76 inHg)	0.4 - 0.6

#### CAUTION:

- Always calibrate the vacuum pump gauge when using it.
  - Do not apply below -20 kPa (-150 mmHg, -5.91 inHg) or over 20 kPa (150 mmHg, 5.91 inHg) of pressure.
6. If NG, replace EVAP control system pressure sensor.

# DTC P0450 EVAPORATIVE EMISSION (EVAP) CONTROL SYSTEM PRESSURE SENSOR

Component Inspection (Cont'd)

## CAUTION:

- Never apply force to the air hole protector of the sensor if equipped.
- Discard and EVAP control system pressure sensor which has been dropped from a height of more than 0.5m (19.7in) onto a hard surface such as a concrete floor; use a new one.

GI

MA

EM

LC

**EC**

FE

CL

MT

AT

TF

PD

FA

RA

BR

ST

RS

BT

HA

EL

IDX

# DTC P0500 VEHICLE SPEED SENSOR (VSS)

## Component Description

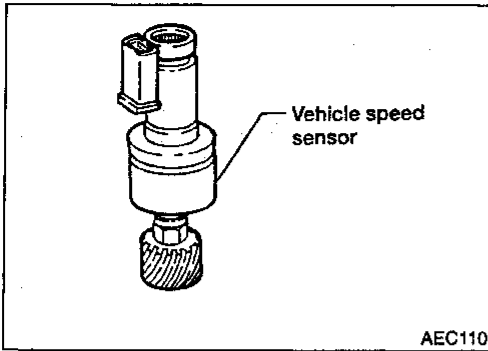

## Component Description

The vehicle speed sensor is installed in the transaxle. It contains a pulse generator which provides a vehicle speed signal to the speedometer. The speedometer then sends a signal to the ECM.

NEEC0239

## ECM Terminals and Reference Value

NEEC0240

Specification data are reference values and are measured between each terminal and 32 (ECM ground).

TERMI- NAL NO.	WIRE COLOR	ITEM	CONDITION	DATA (DC Voltage)
29	G/B	Vehicle speed sensor	<p>[Engine is running]</p> <ul style="list-style-type: none"> <li>Lift up the vehicle</li> <li>In 1st gear position</li> <li>Vehicle speed is 40 km/h (25 MPH)</li> </ul>	<p>2 - 3V</p> <p>SEF996U</p>

## On Board Diagnosis Logic

NEEC0241

DTC No.	Malfunction is detected when ...	Check Items (Possible Cause)
P0500 0104	<ul style="list-style-type: none"> <li>The almost 0 km/h (0 MPH) signal from vehicle speed sensor is sent to ECM even when vehicle is being driven.</li> </ul>	<ul style="list-style-type: none"> <li>Harness or connector (The vehicle speed sensor circuit is open or shorted.)</li> <li>Vehicle speed sensor</li> </ul>

## DTC Confirmation Procedure

NEEC0242

### CAUTION:

Always drive vehicle at a safe speed.

### NOTE:

If "DTC Confirmation Procedure" has been previously conducted, always turn ignition switch "OFF" and wait at least 5 seconds before conducting the next test.

### TESTING CONDITION:

Steps 1 and 2 may be conducted with the drive wheels lifted in the shop or by driving the vehicle. If a road test is expected to be easier, it is unnecessary to lift the vehicle.

### Ⓔ With CONSULT

- Start engine.
- Perform "VEHICLE SPEED SEN CKT" in "FUNCTION TEST" mode with CONSULT.
- If NG, go to "Diagnostic Procedure", EC-334. If OK, go to following step.
- Select "DATA MONITOR" mode with CONSULT.
- Warm engine up to normal operating temperature.

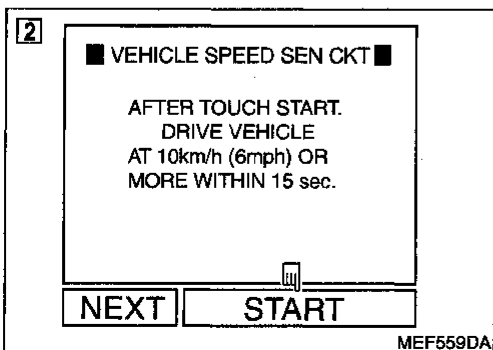



# DTC P0500 VEHICLE SPEED SENSOR (VSS)

DTC Confirmation Procedure (Cont'd)

6

☆ MONITOR	☆ NO FAIL	<input type="checkbox"/>
CMPS-RPM(REF)	2000rpm	
COOLAN TEMP/S	88°C	
B/FUEL SCHDL	3.0msec	
PW/ST SIGNAL	OFF	
VHCL SPEED SE	56km/h	

RECORD

SEF199VD

- 6) Maintain the following conditions for at least 10 consecutive seconds.

CMPS-RPM (REF)	1,400 - 2,800 rpm
COOLAN TEMP/S	More than 70°C (158°F)
B/FUEL SCHDL	2.3 - 4.5 msec
Selector lever	Suitable position
PW/ST SIGNAL	OFF

- 7) If 1st trip DTC is detected, go to "Diagnostic Procedure", EC-334.

5

☆ MONITOR	☆ NO FAIL	<input type="checkbox"/>
CMPS-RPM(REF)	2000rpm	
COOLAN TEMP/S	88°C	
B/FUEL SCHDL	3.0msec	
PW/ST SIGNAL	OFF	
VHCL SPEED SE	56km/h	

RECORD

SEF199VA

## Ⓜ With CONSULT

- 1) Start engine
- 2) Read "VHCL SPEED SE" in "DATA MONITOR" mode with CONSULT. The vehicle speed on CONSULT should exceed 10 km/h (6 MPH) when rotating wheels with suitable gear position. If NG, go to "Diagnostic Procedure", EC-334. If OK, go to following step.
- 3) Select "DATA MONITOR" mode with CONSULT.
- 4) Warm engine up to normal operating temperature.
- 5) Maintain the following conditions for at least 10 consecutive seconds.

CMPS-RPM (REF)	1,400 - 2,800 rpm
COOLAN TEMP/S	More than 70°C (158°F)
B/FUEL SCHDL	2.3 - 4.5 msec
Selector lever	Suitable position
PW/ST SIGNAL	OFF

- 6) If 1st trip DTC is detected, go to "Diagnostic Procedure", EC-334.

## Overall Function Check

Use this procedure to check the overall function of the vehicle speed sensor circuit. During this check, a 1st trip DTC might not be confirmed.

### Ⓜ With GST

- 1) Lift up drive wheels.
- 2) Start engine.
- 3) Read vehicle speed sensor signal in "MODE 1" with GST. The vehicle speed sensor on GST should be able to exceed 10 km/h (6 MPH) when rotating wheels with suitable gear position.

EC-331

GI  
MA  
EM  
LC  
EC  
FE  
CL  
MT  
AT  
TF  
PD  
FA  
RA  
BR  
ST  
RS  
BT  
HA  
EL  
IDX

## DTC P0500 VEHICLE SPEED SENSOR (VSS)

Overall Function Check (Cont'd)

- 4) If NG, go to "Diagnostic Procedure", EC-334.

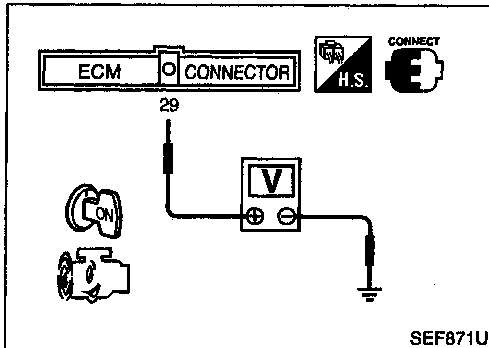

### No Tools

- 1) Lift up drive wheels.
- 2) Start engine.
- 3) Read the voltage signal between ECM terminal 29 (Vehicle speed sensor signal) and ground with oscilloscope.
- 4) Verify that the oscilloscope screen shows the signal wave as shown at "ECM Terminals and Reference Value" on the previous page.
- 5) If NG, go to "Diagnostic Procedure", EC-334.

# DTC P0500 VEHICLE SPEED SENSOR (VSS)

Wiring Diagram

## Wiring Diagram

NEEC0243

EC-VSS-01

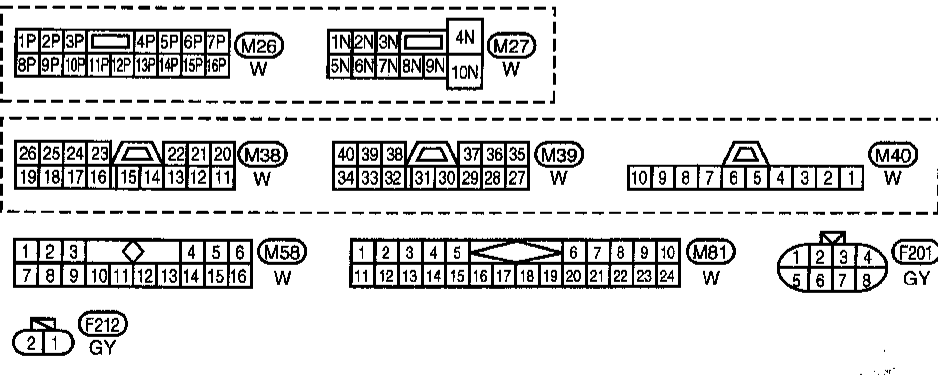
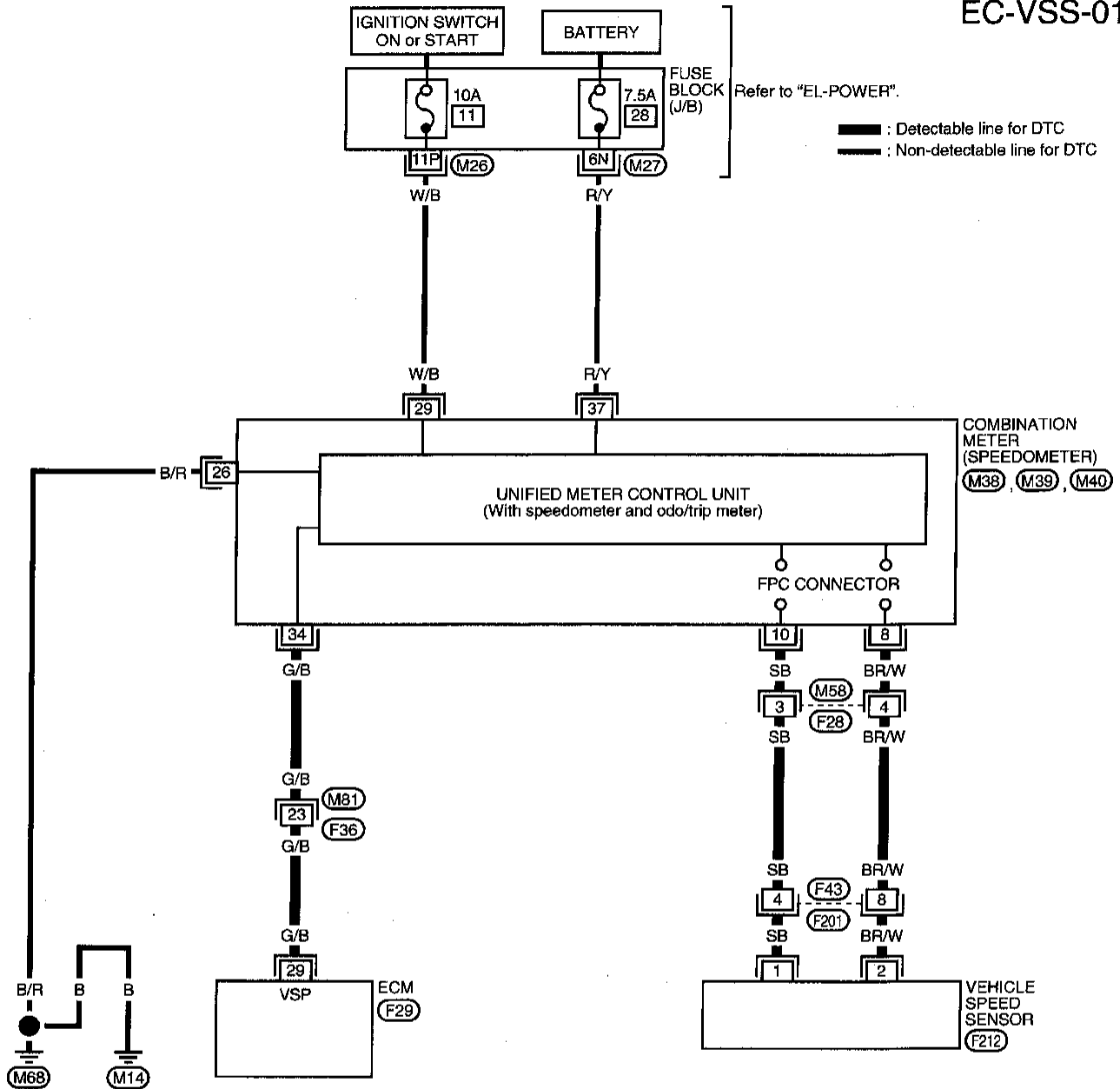

Refer to last page (Foldout page). (F29)

AEC759A

# DTC P0500 VEHICLE SPEED SENSOR (VSS)

Diagnostic Procedure

## Diagnostic Procedure

NEEC0244

<b>1</b>	<b>CHECK INPUT SIGNAL CIRCUIT</b>
<p>1. Turn ignition switch "OFF".</p> <p>2. Disconnect ECM harness connector and combination meter harness connector.</p> <p>3. Check harness continuity between ECM terminal 29 and meter terminal 34.</p>	
SEF650W	
<p>Continuity should exist.</p> <p>4. Also check harness for short to ground and short to power.</p> <p style="text-align: center;"><b>OK or NG</b></p>	
OK	▶ GO TO 3.
NG	▶ GO TO 2.

<b>5</b>	<b>CHECK INTERMITTENT INCIDENT</b>
<p>Refer to "TROUBLE DIAGNOSIS FOR INTERMITTENT INCIDENT", EC-115.</p>	
▶ <b>INSPECTION END</b>	

<b>2</b>	<b>DETECT MALFUNCTIONING PART</b>
<p>Check the following.</p> <ul style="list-style-type: none"> <li>• Harness connectors M81, F36</li> <li>• Harness for open or short between ECM and combination meter</li> </ul>	
▶ Repair open circuit or short to ground or short to power in harness or connectors.	

<b>3</b>	<b>CHECK SPEEDOMETER FUNCTION</b>
<p>Make sure that speedometer functions properly.</p> <p style="text-align: center;"><b>OK or NG</b></p>	
OK	▶ GO TO 5.
NG	▶ GO TO 4.

<b>4</b>	<b>CHECK SPEEDOMETER CIRCUIT</b>
<p>Check the following.</p> <ul style="list-style-type: none"> <li>• Harness connectors M58, F28</li> <li>• Harness connectors F43, F201</li> <li>• Harness for open or short between combination meter and vehicle speed sensor</li> </ul> <p style="text-align: center;"><b>OK or NG</b></p>	
OK	▶ Check combination meter and vehicle speed sensor. Refer to EL section.
NG	▶ Repair open circuit or short to ground or short to power in harness or connectors.

# DTC P0505 IDLE AIR CONTROL VALVE (IACV) — AUXILIARY AIR CONTROL (AAC) VALVE

Description

## Description SYSTEM DESCRIPTION

NEEC0245

NEEC0245S01

Sensor	Input Signal to ECM	ECM function	Actuator
Camshaft position sensor	Engine speed	Idle air control	IACV-AAC valve
Mass air flow sensor	Amount of intake air		
Engine coolant temperature sensor	Engine coolant temperature		
Ignition switch	Start signal		
Throttle position sensor	Throttle position		
Park/neutral position (PNP) switch	Park/neutral position		
Air conditioner switch	Air conditioner operation		
Power steering oil pressure switch	Power steering load signal		
Battery	Battery voltage		
Vehicle speed sensor	Vehicle speed		
Ambient air temperature switch	Ambient air temperature		
Intake air temperature sensor	Intake air temperature		
Absolute pressure sensor	Ambient barometric pressure		

This system automatically controls engine idle speed to a specified level. Idle speed is controlled through fine adjustment of the amount of air which bypasses the throttle valve via IACV-AAC valve. The IACV-AAC valve repeats ON/OFF operation according to the signal sent from the ECM. The camshaft position sensor detects the actual engine speed and sends a signal to the ECM. The ECM then controls the ON/OFF time of the IACV-AAC valve so that engine speed coincides with the target value memorized in ECM. The target engine speed is the lowest speed at which the engine can operate steadily. The optimum value stored in the ECM is determined by taking into consideration various engine conditions, such as during warm up, deceleration, and engine load (air conditioner and power steering).

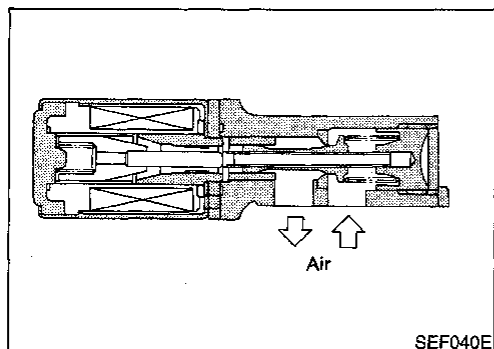

## COMPONENT DESCRIPTION IACV-AAC Valve

NEEC0245S02

NEEC0245S0201

The IACV-AAC valve is moved by ON/OFF pulses from the ECM. The longer the ON pulse, the greater the amount of air that will flow through the valve. The more air that flows through the valve, the higher the idle speed.

# DTC P0505 IDLE AIR CONTROL VALVE (IACV) — AUXILIARY AIR CONTROL (AAC) VALVE

CONSULT Reference Value in Data Monitor Mode

## CONSULT Reference Value in Data Monitor Mode

NEEC0246

Specification data are reference values.

MONITOR ITEM	CONDITION	SPECIFICATION
IACV-AAC/V	<ul style="list-style-type: none"> <li>Engine: After warming up</li> <li>Air conditioner switch: "OFF"</li> <li>Shift lever: "N"</li> <li>No-load</li> </ul>	Idle
		2,000 rpm

## ECM Terminals and Reference Value

NEEC0247

Specification data are reference values and are measured between each terminal and 32 (ECM ground).

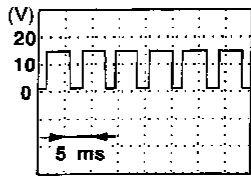
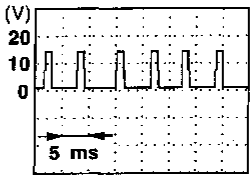
TERMI- NAL NO.	WIRE COLOR	ITEM	CONDITION	DATA (DC Voltage)
101	OR/L	IACV-AAC valve	<p>[Engine is running]</p> <ul style="list-style-type: none"> <li>Warm-up condition</li> <li>Idle speed</li> </ul>	<p>8 - 11V</p>  <p>SEF005V</p>
			<p>[Engine is running]</p> <ul style="list-style-type: none"> <li>Warm-up condition</li> <li>Engine speed is 3,000 rpm</li> </ul>	<p>7 - 10V</p>  <p>SEF692W</p>

## On Board Diagnosis Logic

NEEC0248

DTC No.	Malfunction is detected when ...	Check Items (Possible Cause)
P0505 0808	A) The IACV-AAC valve does not operate properly.	<ul style="list-style-type: none"> <li>Harness or connectors (The IACV-AAC valve circuit is open.)</li> <li>IACV-AAC valve</li> </ul>
	B) The IACV-AAC valve does not operate properly.	<ul style="list-style-type: none"> <li>Harness or connectors (The IACV-AAC valve circuit is shorted.)</li> <li>IACV-AAC valve</li> </ul>

## DTC Confirmation Procedure

NEEC0249

### NOTE:

- If "DTC Confirmation Procedure" has been previously conducted, always turn ignition switch "OFF" and wait at least 5 seconds before conducting the next test.
- Perform "PROCEDURE FOR MALFUNCTION A" first. If 1st trip DTC cannot be confirmed, perform "PROCEDURE FOR MALFUNCTION B".

# DTC P0505 IDLE AIR CONTROL VALVE (IACV) — AUXILIARY AIR CONTROL (AAC) VALVE

DTC Confirmation Procedure (Cont'd)

**2**

☆ MONITOR	☆ NO FAIL	<input type="checkbox"/>
CMPS•RPM(REF)	0rpm	
<b>RECORD</b>		

SEF360VA

## PROCEDURE FOR MALFUNCTION A

NEEC0249S01

### TESTING CONDITION:

Before performing the following procedure, confirm that battery voltage is more than 10.5V with ignition switch "ON".

#### ⓐ With CONSULT

- 1) Turn ignition switch "ON".
- 2) Select "DATA MONITOR" mode with CONSULT.
- 3) Wait at least 2 seconds.
- 4) If 1st trip DTC is detected, go to "Diagnostic Procedure", EC-340.

#### ⓑ With GST

- 1) Turn ignition switch "ON" and wait at least 2 seconds.
- 2) Select "MODE 7" with GST.
- 3) If 1st trip DTC is detected, go to "Diagnostic Procedure", EC-340.

#### ⓒ No Tools

- 1) Turn ignition switch "ON" and wait at least 2 seconds.
- 2) Turn ignition switch "OFF", wait at least 5 seconds and then turn "ON".
- 3) Perform "Diagnostic Test Mode II (Self-diagnostic results)" with ECM.
- 4) If 1st trip DTC is detected, go to "Diagnostic Procedure", EC-340.

**4**

☆ MONITOR	☆ NO FAIL	<input type="checkbox"/>
CMPS•RPM(REF)	750rpm	
COOLAN TEMP/S	85°C	
<b>RECORD</b>		

SEF361VC

## PROCEDURE FOR MALFUNCTION B

NEEC0249S02

### TESTING CONDITION:

Before performing the following procedure, confirm that battery voltage is more than 11V at idle.

#### ⓐ With CONSULT

- 1) Start engine and warm it up to normal operating temperature.
- 2) Turn ignition switch "OFF" and wait at least 5 seconds.
- 3) Turn ignition switch "ON" again and select "DATA MONITOR" mode with CONSULT.
- 4) Start engine and run it for at least 1 minute at idle speed.
- 5) If 1st trip DTC is detected, go to "Diagnostic Procedure", EC-340.

#### ⓑ With GST

- 1) Start engine and warm it up to normal operating temperature.
- 2) Turn ignition switch "OFF" and wait at least 5 seconds.
- 3) Start engine again and run it for at least 1 minute at idle speed.
- 4) Select "MODE 7" with GST.
- 5) If 1st trip DTC is detected, go to "Diagnostic Procedure", EC-340.

#### ⓒ No Tools

- 1) Start engine and warm it up to normal operating temperature.

GI  
MA  
EM  
LC  
EC  
FE  
CL  
MT  
AT  
TF  
PD  
FA  
RA  
BR  
ST  
RS  
BT  
HA  
EL  
IDX

## **DTC P0505 IDLE AIR CONTROL VALVE (IACV) — AUXILIARY AIR CONTROL (AAC) VALVE**

### *DTC Confirmation Procedure (Cont'd)*

---

- 2) Turn ignition switch "OFF" and wait at least 5 seconds.
- 3) Start engine again and run it for at least 1 minute at idle speed.
- 4) Turn ignition switch "OFF", wait at least 5 seconds and then turn "ON".
- 5) Perform "Diagnostic Test Mode II (Self-diagnostic results)" with ECM.
- 6) If 1st trip DTC is detected, go to "Diagnostic Procedure", EC-340.



# DTC P0505 IDLE AIR CONTROL VALVE (IACV) — AUXILIARY AIR CONTROL (AAC) VALVE

Wiring Diagram

## Wiring Diagram

NEEC0250

EC-AAC/V-01

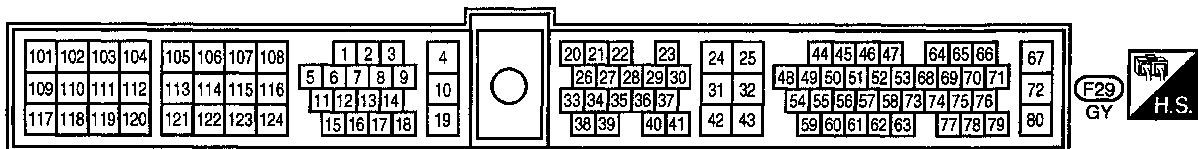
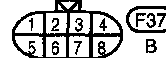
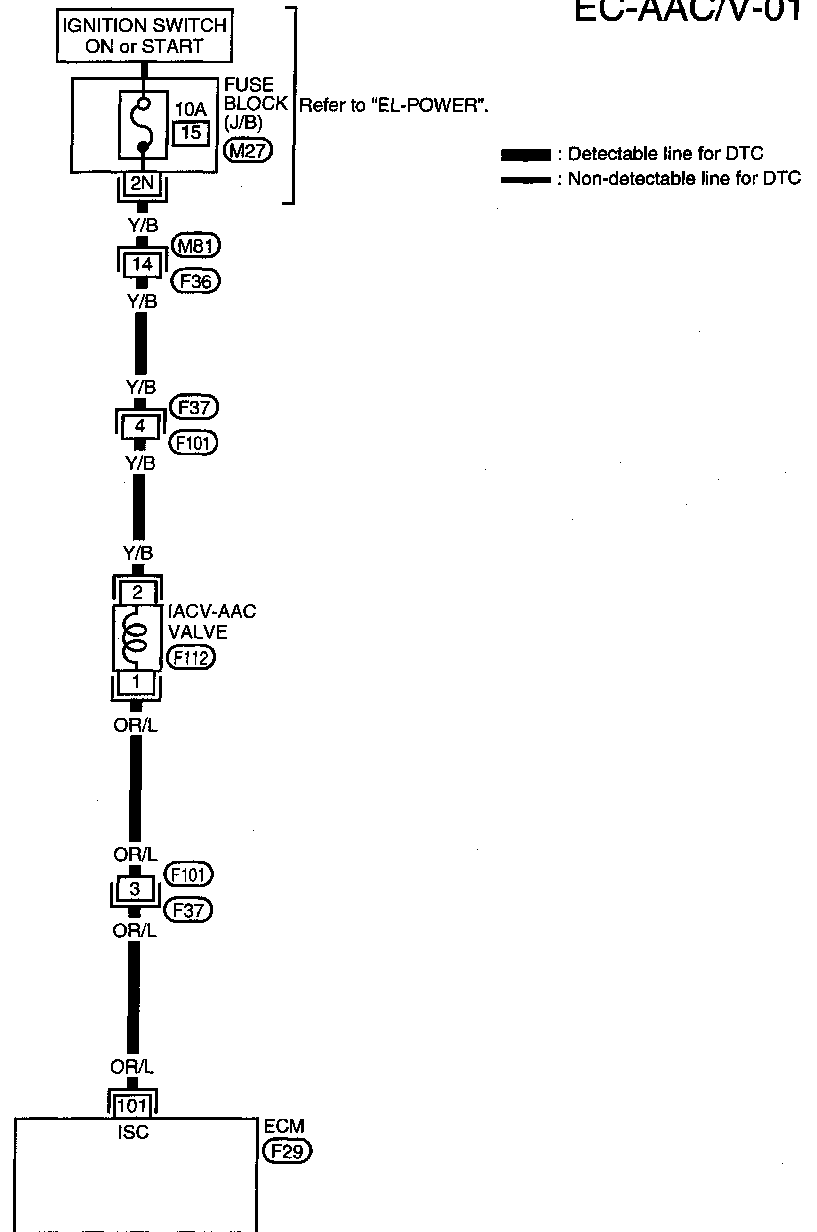

AEC760A

# DTC P0505 IDLE AIR CONTROL VALVE (IACV) — AUXILIARY AIR CONTROL (AAC) VALVE

Diagnostic Procedure

## Diagnostic Procedure

NEEQ0251

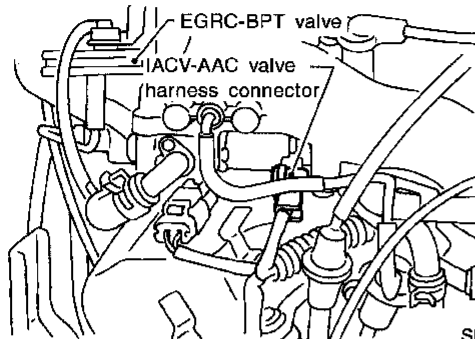
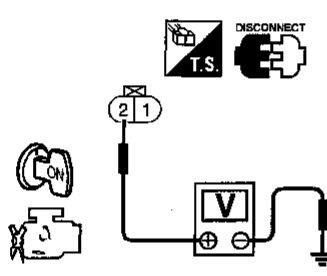
<b>1</b>	<b>CHECK POWER SUPPLY</b>						
<p>1. Stop engine. 2. Disconnect IACV-AAC valve harness connector.</p>  <p style="text-align: right;">SEF007S</p> <p>3. Turn ignition switch "ON". 4. Check voltage between terminal 2 and ground with CONSULT or tester.</p>  <p style="text-align: right;">SEF651W</p> <p style="text-align: center;"><b>Voltage: Battery voltage</b></p> <p style="text-align: center;"><b>OK or NG</b></p> <table border="1" style="width: 100%;"> <tr> <td>OK</td> <td>▶</td> <td>GO TO 3.</td> </tr> <tr> <td>NG</td> <td>▶</td> <td>GO TO 2.</td> </tr> </table>		OK	▶	GO TO 3.	NG	▶	GO TO 2.
OK	▶	GO TO 3.					
NG	▶	GO TO 2.					

<b>2</b>	<b>DETECT MALFUNCTIONING PART</b>
<p>Check the following.</p> <ul style="list-style-type: none"> <li>• Harness connectors M81, F36</li> <li>• Harness connectors F37, F101</li> <li>• Fuse block (J/B) connector M27</li> <li>• 10A fuse</li> <li>• Harness for open or short between IACV-AAC valve and fuse</li> </ul> <p style="text-align: right;">▶ Repair harness or connectors.</p>	

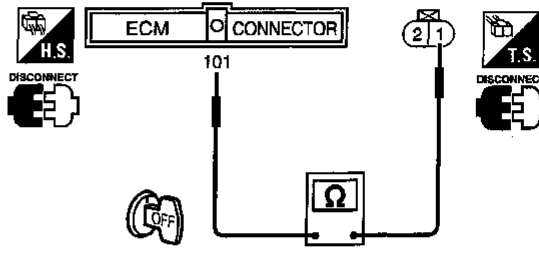
<b>3</b>	<b>CHECK OUTPUT SIGNAL CIRCUIT</b>						
<p>1. Turn ignition switch "OFF". 2. Disconnect ECM harness connector. 3. Check harness continuity between ECM terminal 101 and terminal 1.</p>  <p style="text-align: right;">SEF652W</p> <p style="text-align: center;"><b>Continuity should exist.</b></p> <p>4. Also check harness for short to ground and short to power.</p> <p style="text-align: center;"><b>OK or NG</b></p> <table border="1" style="width: 100%;"> <tr> <td>OK</td> <td>▶</td> <td>GO TO 5.</td> </tr> <tr> <td>NG</td> <td>▶</td> <td>GO TO 4.</td> </tr> </table>		OK	▶	GO TO 5.	NG	▶	GO TO 4.
OK	▶	GO TO 5.					
NG	▶	GO TO 4.					

<b>4</b>	<b>DETECT MALFUNCTIONING PART</b>
<p>Check the following.</p> <ul style="list-style-type: none"> <li>• Harness connectors F101, F37</li> <li>• Harness for open or short between IACV-AAC valve and ECM</li> </ul> <p style="text-align: right;">▶ Repair open circuit or short to ground or short to power in harness or connectors.</p>	

<b>5</b>	<b>CHECK IACV-AAC VALVE</b>						
<p>Refer to "Component Inspection", EC-341.</p> <p style="text-align: center;"><b>OK or NG</b></p> <table border="1" style="width: 100%;"> <tr> <td>OK</td> <td>▶</td> <td>GO TO 6.</td> </tr> <tr> <td>NG</td> <td>▶</td> <td>Replace IACV-AAC valve.</td> </tr> </table>		OK	▶	GO TO 6.	NG	▶	Replace IACV-AAC valve.
OK	▶	GO TO 6.					
NG	▶	Replace IACV-AAC valve.					

<b>6</b>	<b>CHECK INTERMITTENT INCIDENT</b>
<p>Refer to "TROUBLE DIAGNOSIS FOR INTERMITTENT INCIDENT", EC-115.</p> <p style="text-align: right;">▶ INSPECTION END</p>	

# DTC P0505 IDLE AIR CONTROL VALVE (IACV) — AUXILIARY AIR CONTROL (AAC) VALVE

Component Inspection

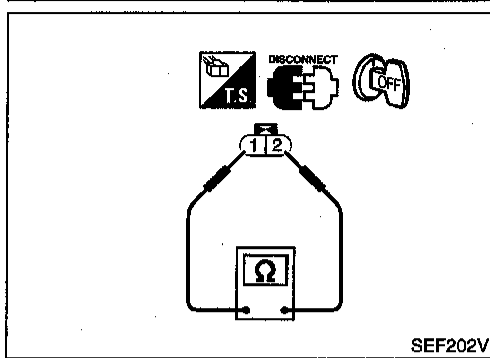

## Component Inspection

### IACV-AAC VALVE

NEEC0252

NEEC0252S01

1. Disconnect IACV-AAC valve harness connector.
2. Remove IACV-AAC valve.
  - Check IACV-AAC valve resistance.

#### Resistance:

**Approximately 10Ω [at 20°C (68°F)]**

- Check plunger for seizing or sticking.
  - Check for broken spring.
3. Supply battery voltage between IACV-AAC valve connector terminals.

**Plunger should move.**

GI

MA

EM

LC

**EC**

FE

CL

MT

AT

TF

PD

FA

RA

BR

ST

RS

BT

HA

EL

IDX

# DTC P0510 CLOSED THROTTLE POSITION SWITCH

## Component Description

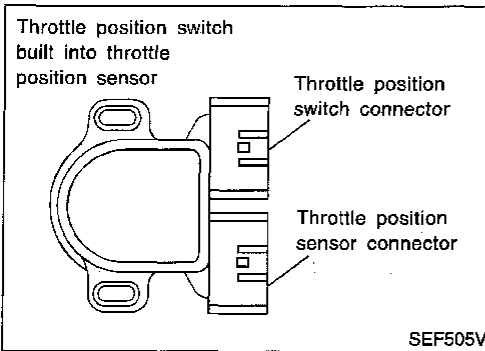

## Component Description

NEEC0253

A closed throttle position switch and wide open throttle position switch are built into the throttle position sensor unit. The wide open throttle position switch is used only for A/T control.

When the throttle valve is in the closed position, the closed throttle position switch sends a voltage signal to the ECM. The ECM only uses this signal to open or close the EVAP canister purge volume control solenoid valve when the throttle position sensor is malfunctioning.

## CONSULT Reference Value in Data Monitor Mode

NEEC0537

Specification data are reference values.

MONITOR ITEM	CONDITION	SPECIFICATION
CLSD THL/P SW	• Engine: After warming up, idle the engine	Throttle valve: Idle position ON
		Throttle valve: Slightly open OFF

## ECM Terminals and Reference Value

NEEC0255

Specification data are reference values and are measured between each terminal and 32 (ECM ground).

TER-MINAL NO.	WIRE COLOR	ITEM	CONDITION	DATA (DC Voltage)
28	BR/W	Throttle position switch (Closed position)	[Engine is running] • Warm-up condition • Accelerator pedal fully released	BATTERY VOLTAGE (11 - 14V)
			[Ignition switch "ON"] • Accelerator pedal depressed	Approximately 0V

## On Board Diagnosis Logic

NEEC0256

DTC No.	Malfunction is detected when ...	Check Items (Possible Cause)
P0510 0203	• Battery voltage from the closed throttle position switch is sent to ECM with the throttle valve opened.	• Harness or connectors (The closed throttle position switch circuit is shorted.) • Closed throttle position switch • Throttle position sensor

# DTC P0510 CLOSED THROTTLE POSITION SWITCH

DTC Confirmation Procedure

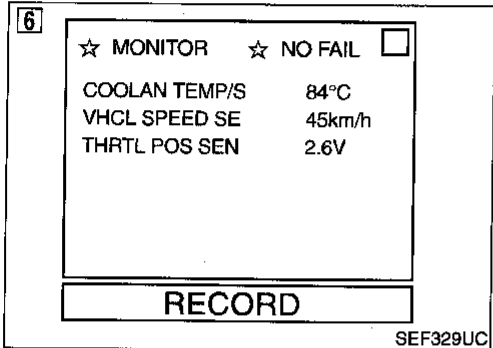
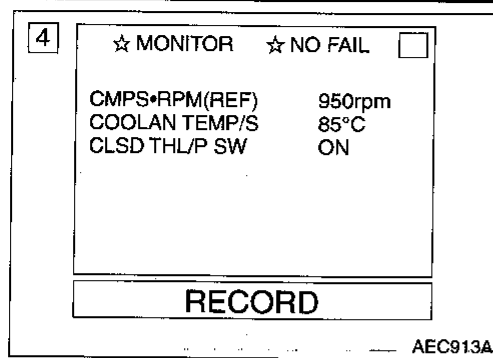

## DTC Confirmation Procedure

NEEC0257

### CAUTION:

Always drive vehicle at a safe speed.

### NOTE:

If "DTC Confirmation Procedure" has been previously conducted, always turn ignition switch "OFF" and wait at least 5 seconds before conducting the next test.

#### ④ With CONSULT

- 1) Start engine and warm it up to normal operating temperature.
- 2) Turn ignition switch "OFF", wait at least 5 seconds and then start engine.
- 3) Select "CLSD THL/P SW" in "DATA MONITOR" mode.
- 4) Check the signal under the following conditions.

Condition	Signal indication
Throttle valve: Idle position	ON
Throttle valve: Slightly open	OFF

If the result is NG, go to "Diagnostic Procedure", EC-345.  
If OK, go to following step.

- 5) Select "DATA MONITOR" mode with CONSULT.
- 6) Drive the vehicle for at least 5 consecutive seconds under the following condition.

THRTL POS SEN	More than 2.5V
VHCL SPEED SE	More than 4 km/h (2 MPH)
Selector lever	Suitable position
Driving location	Driving vehicle uphill (Increased engine load) will help maintain the driving conditions required for this test.

- 7) If 1st trip DTC is detected, go to "Diagnostic Procedure", EC-345.

## Overall Function Check

NEEC0469

Use this procedure to check the overall function of the closed throttle position switch circuit. During this check, a 1st trip DTC might not be confirmed.

#### ④ Without CONSULT

- 1) Start engine and warm it up to normal operating temperature.
- 2) Check the voltage between ECM terminal 28 (Closed throttle position switch signal) and ground under the following conditions.

**At idle: Battery voltage**

**At 2,000 rpm: Approximately 0V**

- 3) If NG, go to "Diagnostic Procedure", EC-345.

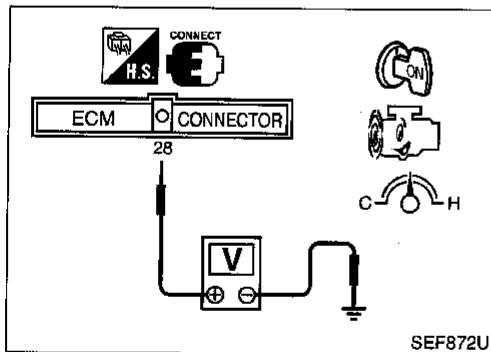

SEF872U

GI  
MA  
EM  
LC  
EC  
FE  
CL  
MT  
AT  
TF  
PD  
FA  
RA  
BR  
ST  
RS  
BT  
HA  
EL  
IDX

# DTC P0510 CLOSED THROTTLE POSITION SWITCH

Wiring Diagram

## Wiring Diagram

NEEC0258

EC-TP/SW-01

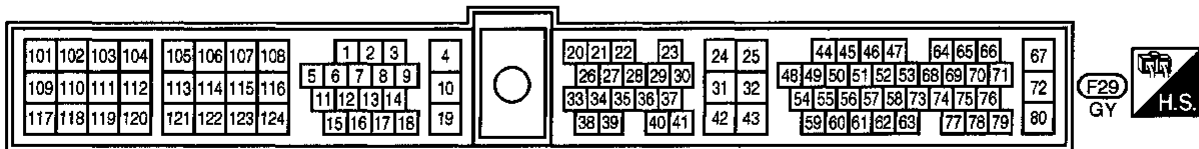
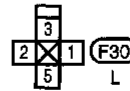
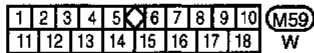
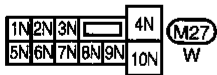
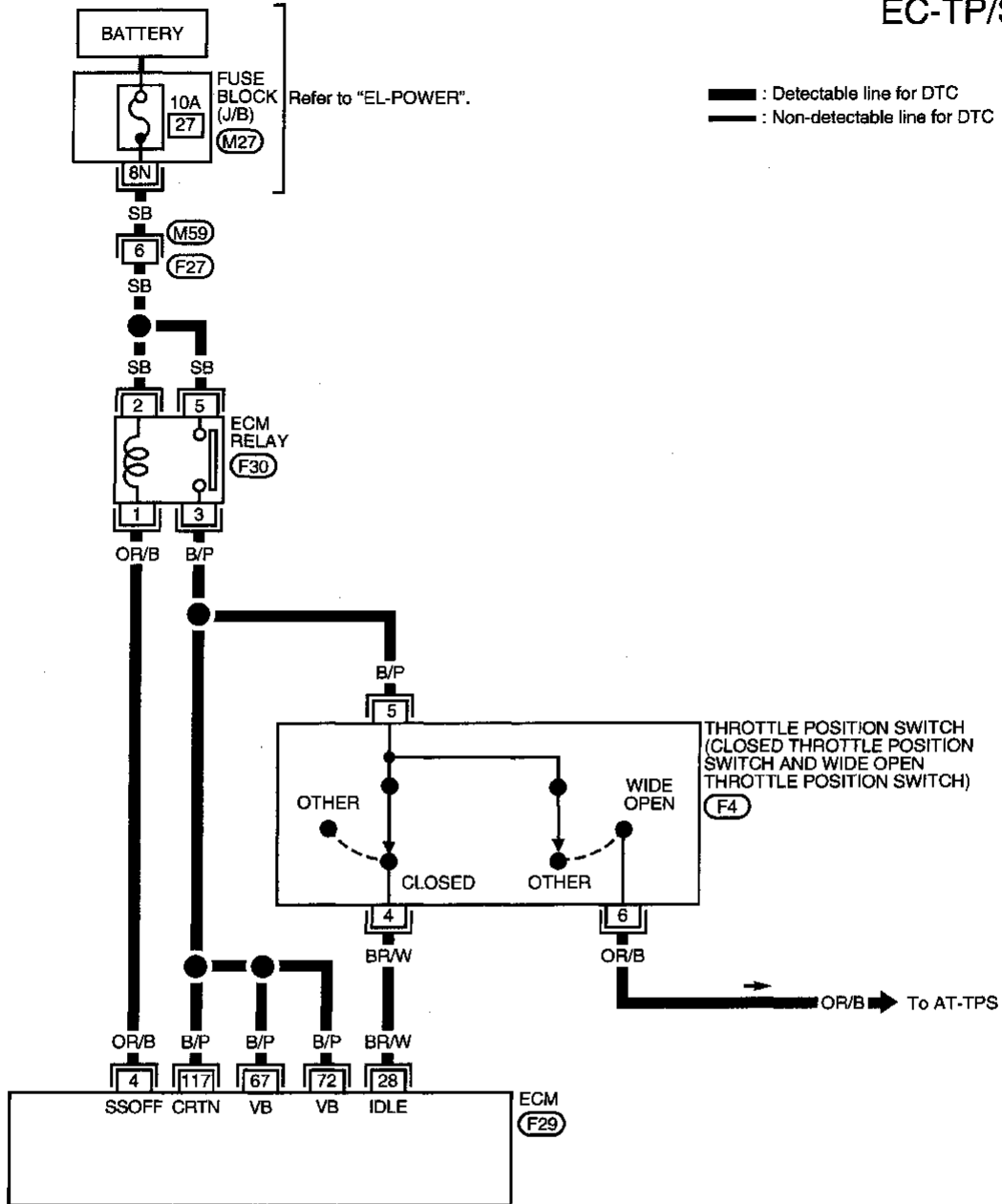

AEC761A

# DTC P0510 CLOSED THROTTLE POSITION SWITCH

Diagnostic Procedure

NEEC0259

## Diagnostic Procedure

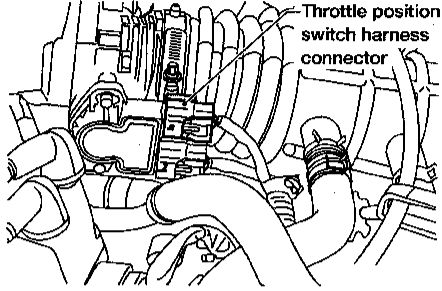
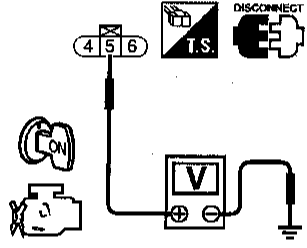
<b>1</b>	<b>CHECK POWER SUPPLY</b>
<p>1. Turn ignition switch "OFF". 2. Disconnect throttle position switch harness connector.</p>	
 <p style="text-align: right;">Throttle position switch harness connector</p>	
AEC653A	
<p>3. Turn ignition switch "ON". 4. Check voltage between terminal 5 and engine ground with CONSULT or tester.</p>	
	
<p><b>Voltage: Battery voltage</b></p> <p><b>OK or NG</b></p>	
OK	▶ GO TO 3.
NG	▶ GO TO 2.

<b>2</b>	<b>DETECT MALFUNCTIONING PART</b>
<p>Check the following.</p> <ul style="list-style-type: none"> <li>• Harness for open or short between throttle position switch and ECM relay</li> <li>• Harness for open or short between throttle position switch and ECM</li> </ul>	
▶ Repair harness or connectors.	

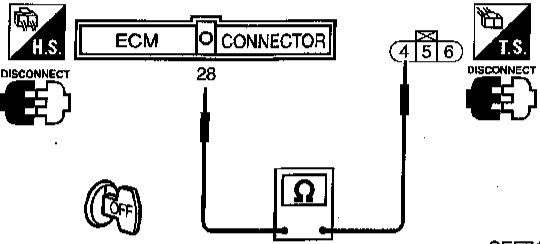
<b>3</b>	<b>CHECK INPUT SIGNAL CIRCUIT</b>
<p>1. Turn ignition switch "OFF". 2. Disconnect ECM harness connector. 3. Check harness continuity between ECM terminal 28 and terminal 4.</p>	
	
<p><b>Continuity should exist.</b></p> <p>4. Also check harness for short to ground and short to power.</p> <p><b>OK or NG</b></p>	
OK	▶ GO TO 4.
NG	▶ Repair open circuit or short to ground or short to power in harness or connectors.

<b>4</b>	<b>ADJUST THROTTLE POSITION SWITCH</b>
<p>Perform BASIC INSPECTION, EC-86.</p>	
▶ GO TO 5.	

<b>5</b>	<b>CHECK CLOSED THROTTLE POSITION SWITCH</b>
<p>Refer to "Component Inspection", EC-346.</p> <p style="text-align: center;"><b>OK or NG</b></p>	
OK	▶ GO TO 6.
NG	▶ Replace throttle position switch.

<b>6</b>	<b>CHECK THROTTLE POSITION SENSOR</b>
<p>Refer to "Component Inspection", EC-159.</p> <p style="text-align: center;"><b>OK or NG</b></p>	
OK	▶ GO TO 7.
NG	▶ Replace throttle position sensor.

<b>7</b>	<b>CHECK INTERMITTENT INCIDENT</b>
<p>Refer to "TROUBLE DIAGNOSIS FOR INTERMITTENT INCIDENT", EC-115.</p>	
▶ INSPECTION END	

GI  
MA  
EM  
LC  
EC  
FE  
CL  
MT  
AT  
TF  
PD  
FA  
RA  
BR  
ST  
RS  
BT  
HA  
EL  
IDX

# DTC P0510 CLOSED THROTTLE POSITION SWITCH

## Component Inspection

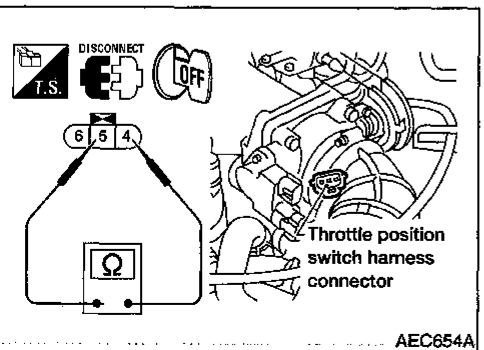
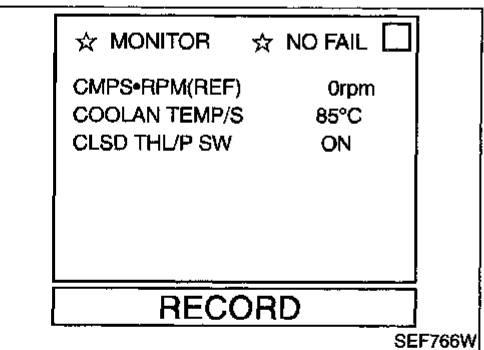
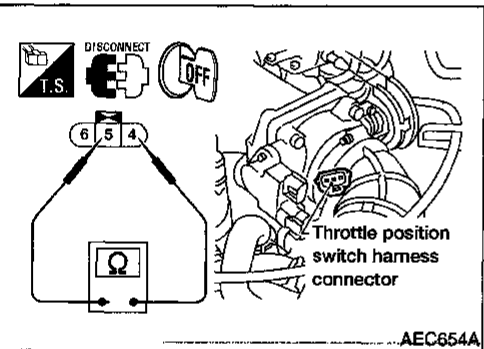
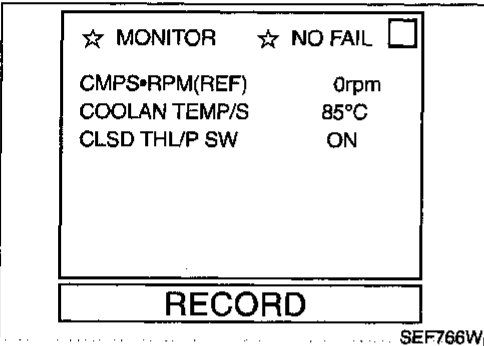
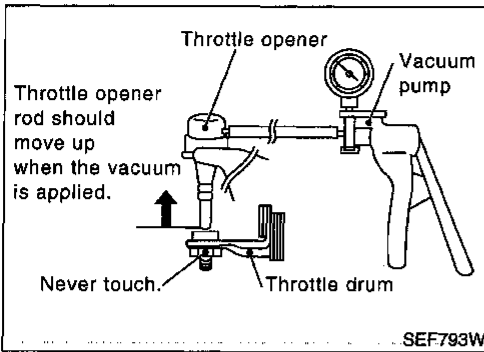

## Component Inspection CLOSED THROTTLE POSITION SWITCH

NEEC0280

NEEC0260S01

### ① With CONSULT

- 1) Start engine and warm it up to normal operating temperature.
- 2) Turn ignition switch "OFF".
- 3) Remove vacuum hose connected to throttle opener.
- 4) Connect suitable vacuum hose to vacuum pump and the throttle opener.
- 5) Apply vacuum [more than -40.0kPa (-300mmHg, 11.81inHg)] until the throttle drum becomes free from the rod of the throttle opener.
- 6) Turn ignition switch "ON".
- 7) Select "DATA MONITOR" mode with CONSULT.
- 8) Check indication of "CLSD THL/P SW".  
Measurement must be made with closed throttle position switch installed in vehicle.

Throttle valve conditions	Continuity
Completely closed	Yes
Partially open or completely open	No

If NG, adjust closed throttle position switch. Refer to "Basic Inspection", EC-86.

- 9) If it is impossible to adjust closed throttle position switch in "Basic Inspection", replace closed throttle position switch.

### ② Without CONSULT

- 1) Start engine and warm it up to normal operating temperature.
- 2) Turn ignition switch "OFF".
- 3) Remove vacuum hose connected to throttle opener.
- 4) Connect suitable vacuum hose to vacuum pump and the throttle opener.
- 5) Apply vacuum [more than -40.0kPa (-300mmHg, 11.81inHg)] until the throttle drum becomes free from the rod of the throttle opener.
- 6) Disconnect closed throttle position switch harness connector.



# DTC P0510 CLOSED THROTTLE POSITION SWITCH

Component Inspection (Cont'd)

- 7) Check continuity between closed throttle position switch terminals 4 and 5.  
Resistance measurement must be made with closed throttle position switch installed in vehicle.

Throttle valve conditions	Continuity
Completely closed	Yes
Partially open or completely open	No

If NG, adjust closed throttle position switch. Refer to "Basic Inspection", EC-86.

- 8) If it is impossible to adjust closed throttle position switch in "Basic Inspection", replace closed throttle position switch.

GI

MA

EM

LC

**EC**

FE

CL

MT

AT

TF

PD

FA

RA

BR

ST

RS

BT

HA

EL

IDX

# DTC P0600 A/T CONTROL

## System Description

### System Description

NEEC0261

These circuit lines are used to control the smooth shifting up and down of A/T during the hard acceleration/ deceleration.

Voltage signals are exchanged between ECM and TCM (Transmission Control Module).

### ECM Terminals and Reference Value

NEEC0262

Specification data are reference values and are measured between each terminal and 32 (ECM ground).

TERMI- NAL NO.	WIRE COLOR	ITEM	CONDITION	DATA (DC Voltage)
26	PU/W	A/T signal No. 1	[[Ignition switch "ON"] [Engine is running] • Idle speed	6 - 8V
27	P/B	A/T signal No. 2	[[Ignition switch "ON"] [Engine is running] • Idle speed	6 - 8V
35	G/R	A/T signal No. 3	[[Ignition switch "ON"]	0V

### On Board Diagnosis Logic

NEEC0263

DTC No.	Malfunction is detected when ...	Check Items (Possible Cause)
P0600*	<ul style="list-style-type: none"> <li>• ECM receives incorrect voltage from TCM (Transmission Control Module) continuously.</li> </ul>	<ul style="list-style-type: none"> <li>• Harness or connectors [The circuit between ECM and TCM (Transmission Control Module) is open or shorted.]</li> </ul>

\*: This DTC can be detected only by "DATA MONITOR (AUTO TRIG)" with CONSULT.

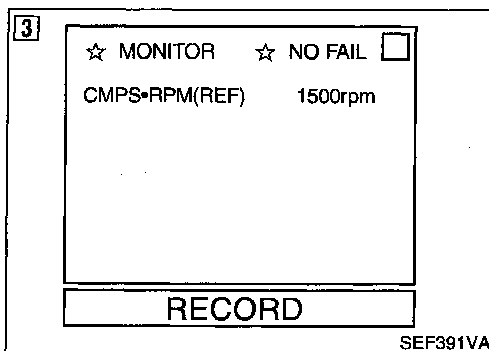

### DTC Confirmation Procedure

NEEC0264

#### NOTE:

If "DTC Confirmation Procedure" has been previously conducted, always turn ignition switch "OFF" and wait at least 5 seconds before conducting the next test.

#### Ⓜ With CONSULT

- 1) Turn ignition switch "ON".
- 2) Select "DATA MONITOR" mode with CONSULT.
- 3) Start engine, and rev engine more than 1,000 rpm once, then let it idle for more than 40 seconds.
- 4) If DTC is detected, go to "Diagnostic Procedure", EC-351.

# DTC P0600 A/T CONTROL

Overall Function Check

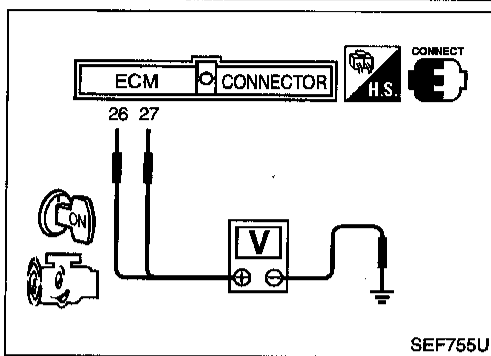

## Overall Function Check

Use this procedure to check the overall function of the A/T control circuit. During this check, a DTC might not be confirmed. NEEC0265

### ⊗ Without CONSULT

- 1) Start engine.
- 2) Check voltage between  
ECM terminal 26 and ground.  
ECM terminal 27 and ground.  
**Voltage: 6 - 8V**
- 3) If NG, go to "Diagnostic Procedure", EC-351.

GI

MA

EM

LC

**EC**

FE

CL

MT

AT

TF

PD

FA

RA

BR

ST

RS

BT

HA

EL

IDX

# DTC P0600 A/T CONTROL

Wiring Diagram

## Wiring Diagram

NEEC0266

EC-AT/C-01

: Detectable line for DTC  
 : Non-detectable line for DTC

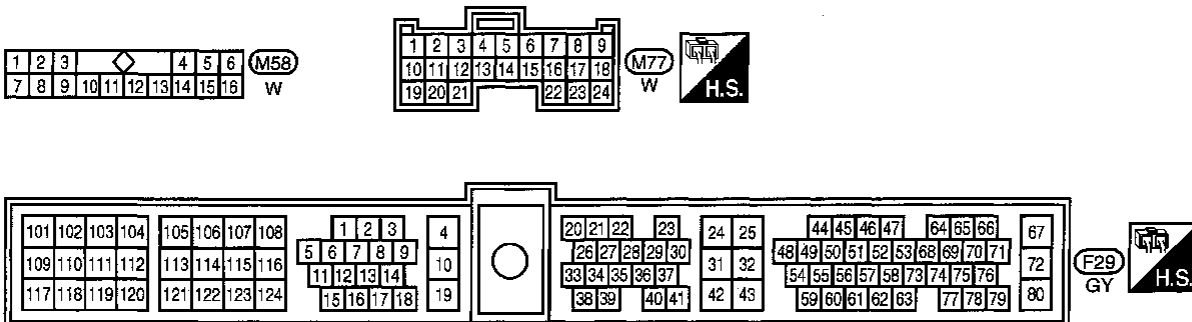
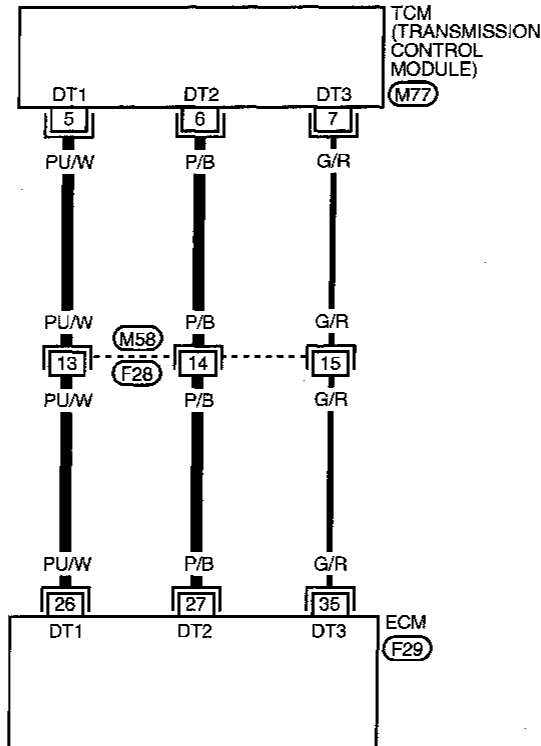

AEC762A

EC-350

## Diagnostic Procedure

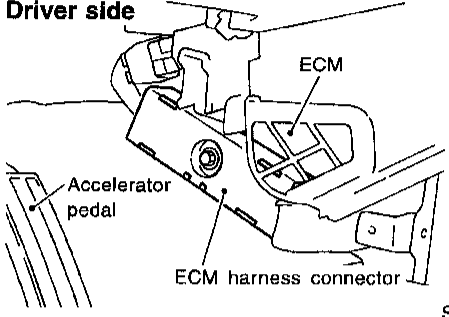
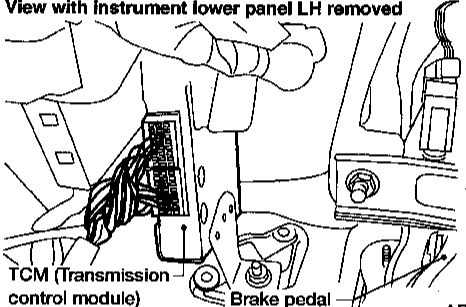
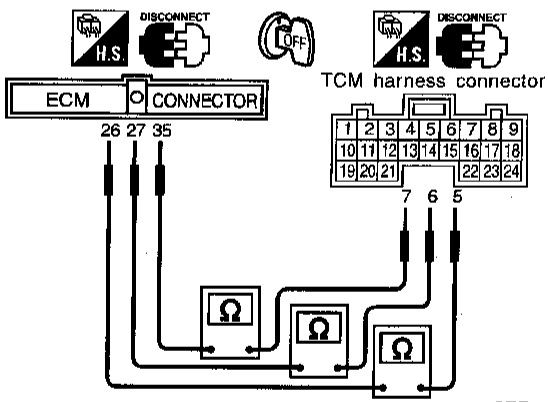
<b>1</b>	<b>CHECK INPUT SIGNAL CIRCUIT</b>						
<p>1. Turn ignition switch "OFF".                  2. Disconnect ECM harness connector and TCM (Transmission Control Module) harness connector.</p> <p style="text-align: center;"><b>Driver side</b></p>  <p style="text-align: right;">SEF324V</p> <p style="text-align: center;"><b>View with instrument lower panel LH removed</b></p>  <p style="text-align: right;">AEC655A</p> <p>3. Check harness continuity between ECM terminal 26 and terminal 5, ECM terminal 27 and terminal 6, ECM terminal 35 and terminal 7.</p>  <p style="text-align: right;">SEF065W</p> <p style="text-align: center;"><b>Continuity should exist.</b></p> <p style="text-align: center;"><b>OK or NG</b></p> <table border="1" style="width: 100%;"> <tr> <td>OK</td> <td>▶</td> <td>GO TO 3.</td> </tr> <tr> <td>NG</td> <td>▶</td> <td>GO TO 2.</td> </tr> </table>		OK	▶	GO TO 3.	NG	▶	GO TO 2.
OK	▶	GO TO 3.					
NG	▶	GO TO 2.					

<b>2</b>	<b>DETECT MALFUNCTIONING PART</b>
<p>Check the following.</p> <ul style="list-style-type: none"> <li>• Harness connectors M58, F28</li> <li>• Harness for open or short between ECM and TCM (Transmission Control Module)</li> </ul> <p style="text-align: right;">▶ Repair harness or connectors.</p>	

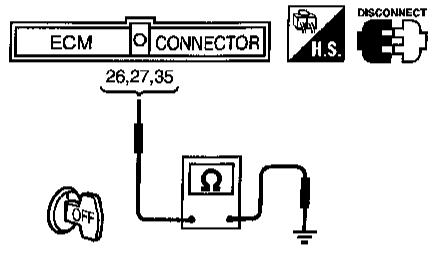
<b>3</b>	<b>CHECK INPUT SIGNAL CIRCUIT</b>						
<p>1. Check harness continuity between ECM terminal 26 and ground, ECM terminal 27 and ground, ECM terminal 35 and ground.</p>  <p style="text-align: right;">SEF718U</p> <p style="text-align: center;"><b>Continuity should not exist.</b></p> <p>2. Also check harness for short to power.</p> <p style="text-align: center;"><b>OK or NG</b></p> <table border="1" style="width: 100%;"> <tr> <td>OK</td> <td>▶</td> <td>GO TO 5.</td> </tr> <tr> <td>NG</td> <td>▶</td> <td>GO TO 4.</td> </tr> </table>		OK	▶	GO TO 5.	NG	▶	GO TO 4.
OK	▶	GO TO 5.					
NG	▶	GO TO 4.					

<b>4</b>	<b>DETECT MALFUNCTIONING PART</b>
<p>Check the harness for open or short between ECM and TCM (Transmission Control Module).</p> <p style="text-align: right;">▶ Repair open circuit or short to ground or short to power in harness.</p>	

<b>5</b>	<b>CHECK INTERMITTENT INCIDENT</b>
<p>Refer to "TROUBLE DIAGNOSIS FOR INTERMITTENT INCIDENT", EC-115.</p> <p style="text-align: right;">▶ INSPECTION END</p>	

GI  
MA  
EM  
LC  
EC  
FE  
CL  
MT  
AT  
TF  
PD  
FA  
RA  
BR  
ST  
RS  
BT  
HA  
EL  
IDX

## DTC P0605 ECM

### Component Description

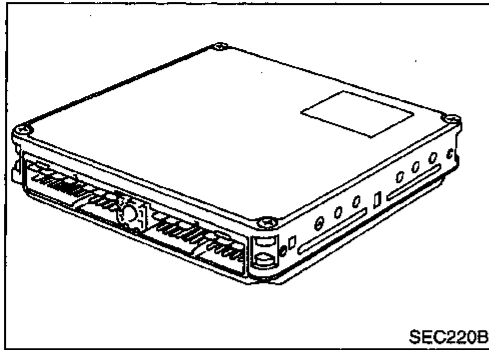

### Component Description

NEEC0268

The ECM consists of a microcomputer, diagnostic test mode selector, and connectors for signal input and output and for power supply. The unit controls the engine.

### On Board Diagnosis Logic

NEEC0269

DTC No.	Malfunction is detected when ...	Check Items (Possible Cause)
P0605 0301	<ul style="list-style-type: none"> <li>ECM calculation function is malfunctioning.</li> </ul>	<ul style="list-style-type: none"> <li>ECM</li> </ul>

### DTC Confirmation Procedure

NEEC0270

#### NOTE:

If "DTC Confirmation Procedure" has been previously conducted, always turn ignition switch "OFF" and wait at least 5 seconds before conducting the next test.

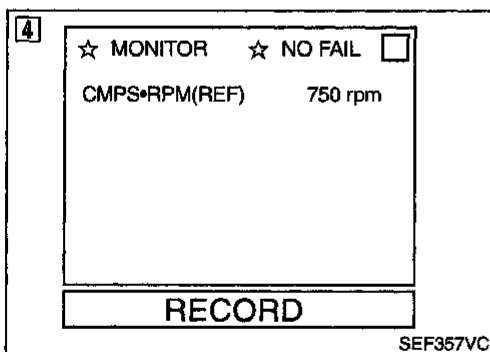

#### ④ With CONSULT

- 1) Turn ignition switch "ON".
- 2) Select "DATA MONITOR" mode with CONSULT.
- 3) Start engine.
- 4) Run engine for at least 2 seconds at idle speed.
- 5) If 1st trip DTC is detected, go to "Diagnostic Procedure", EC-353.

#### Ⓜ With GST

- 1) Turn ignition switch "ON".
- 2) Start engine.
- 3) Run engine for at least 2 seconds at idle speed.
- 4) Select "Mode 7" with GST.
- 5) If 1st trip DTC is detected, go to "Diagnostic Procedure", EC-353.

#### Ⓜ No Tools

- 1) Turn ignition switch "ON".
- 2) Start engine and wait at least 2 seconds.
- 3) Turn ignition switch "OFF", wait at least 5 seconds and then turn "ON".
- 4) Perform "Diagnostic Test Mode II" (Self-diagnostic results) with ECM.

# DTC P0605 ECM



Diagnostic Procedure

- 5) If 1st trip DTC is detected, go to "Diagnostic Procedure", EC-353.

GI  
MA  
EM  
LC  
EC  
FE  
CL  
MT  
AT  
TF  
PD  
FA  
RA  
BR  
ST  
RS  
BT  
HA  
EL  
IDX

## Diagnostic Procedure

NEEC0271

<b>1</b>	<b>INSPECTION START</b>
<p> <b>With CONSULT</b></p> <ol style="list-style-type: none"> <li>1. Turn ignition switch "ON".</li> <li>2. Select "SELF DIAG RESULTS" mode with CONSULT.</li> <li>3. Touch "ERASE".</li> <li>4. Perform "DTC Confirmation Procedure". See EC-352.</li> <li>5. Is the 1st trip DTC P0605 displayed again?</li> </ol>	
<p> <b>With GST</b></p> <ol style="list-style-type: none"> <li>1. Turn ignition switch "ON".</li> <li>2. Select MODE 4 with GST.</li> <li>3. Touch "ERASE".</li> <li>4. Perform "DTC Confirmation Procedure". See EC-352.</li> <li>5. Is the 1st trip DTC P0605 displayed again?</li> </ol>	
<p> <b>No Tools</b></p> <ol style="list-style-type: none"> <li>1. Turn ignition switch "ON".</li> <li>2. Erase the Diagnostic Test Mode II (Self-diagnostic results) memory. Refer to EC-55.</li> <li>3. Perform "DTC Confirmation Procedure". See EC-352.</li> <li>4. Is the 1st trip DTC 0301 displayed again?</li> </ol> <p style="text-align: center;"><b>Yes or No</b></p>	
Yes	▶ Replace ECM.
No	▶ <b>INSPECTION END</b>

# DTC P1105 MANIFOLD ABSOLUTE PRESSURE (MAP)/BAROMETRIC PRESSURE (BARO) SWITCH SOLENOID VALVE

Description

## Description SYSTEM DESCRIPTION

NEEC0279

NEEC0279S01

Sensor	Input Signal to ECM	ECM function	Actuator
Camshaft position sensor	Engine speed	On board diagnosis	MAP/BARO switch solenoid valve
Ignition switch	Start signal		
Throttle position sensor	Throttle position		
Vehicle speed sensor	Vehicle speed		

This system allows the absolute pressure sensor to monitor either ambient barometric pressure or intake manifold pressure. The MAP/BARO switch solenoid valve switches between two passages by ON-OFF pulse signals from the ECM. (One passage is from the intake air duct, the other is from the intake manifold.) Either ambient barometric pressure or intake manifold pressure is applied to the absolute pressure sensor.

Solenoid	Conditions
ON	<ul style="list-style-type: none"> <li>• For 5 seconds after turning ignition switch ON (Engine is not running.)</li> <li style="text-align: center;">or</li> <li>• For 5 seconds after starting engine</li> <li style="text-align: center;">or</li> <li>• More than 5 minutes after the solenoid valve shuts OFF.</li> </ul>

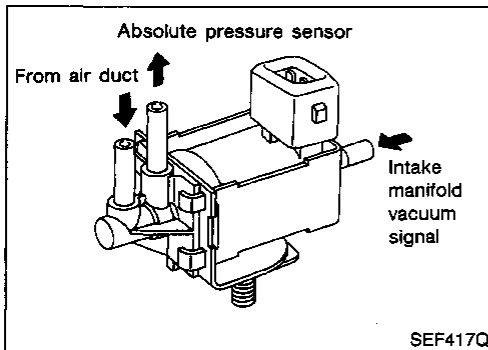

### COMPONENT DESCRIPTION

NEEC0279S02

The MAP/BARO switch solenoid valve switches its air flow passage according to the voltage signal sent from the ECM. When voltage is supplied from the ECM, the MAP/BARO switch solenoid turns "ON". Then, the absolute pressure sensor can monitor the ambient barometric pressure. When voltage is not supplied from the ECM, the MAP/BARO switch solenoid valve turns "OFF". Then, the sensor monitors intake manifold pressure.

### CONSULT Reference Value in Data Monitor Mode

NEEC0280

Specification data are reference values.

MONITOR ITEM	CONDITION	SPECIFICATION	
MAP/BARO SW/V	• Ignition switch: ON (Engine stopped)	MAP	
	• Engine speed: Idle	For 5 seconds after starting engine	BARO
		More than 5 seconds after starting engine	MAP



# DTC P1105 MANIFOLD ABSOLUTE PRESSURE (MAP)/BAROMETRIC PRESSURE (BARO) SWITCH SOLENOID VALVE

ECM Terminals and Reference Value

## ECM Terminals and Reference Value

NEEC0281

Specification data are reference values and are measured between each terminal and 32 (ECM ground).

TERMI- NAL NO.	WIRE COLOR	ITEM	CONDITION	DATA (DC Voltage)
118	Y/B	MAP/BARO switch solenoid valve	<b>[Ignition switch "ON"]</b> <ul style="list-style-type: none"> <li>Engine is not running</li> <li>For 5 seconds after ignition switch is turned "ON"</li> </ul>	0 - 1V
			<b>[Engine is running]</b> <ul style="list-style-type: none"> <li>Idle (for 5 seconds after engine start)</li> </ul>	
			<b>[Ignition switch "ON"]</b> <ul style="list-style-type: none"> <li>Engine is not running</li> <li>More than 5 seconds after ignition switch is turned "ON"</li> </ul>	BATTERY VOLTAGE (11 - 14V)
			<b>[Engine is running]</b> <ul style="list-style-type: none"> <li>Idle (More than 5 seconds after engine start)</li> </ul>	

## On Board Diagnosis Logic

NEEC0282

DTC No.	Malfunction is detected when ...		Check Items (Possible Cause)
P1105 1302	A)	MAP/BARO switch solenoid valve receives the voltage supplied though ECM does not supply the voltage to the valve.	<ul style="list-style-type: none"> <li>Harness or connectors (MAP/BARO switch solenoid valve circuit is open or shorted.)</li> <li>MAP/BARO switch solenoid valve</li> </ul>
	B)	There is little difference between MAP/BARO switch solenoid valve input voltage at ambient barometric pressure and voltage at intake manifold pressure.	<ul style="list-style-type: none"> <li>Harness or connectors (MAP/BARO switch solenoid valve circuit is open or shorted.)</li> <li>Hoses (Hoses are clogged, vent, kinked, disconnected or improper connection.)</li> <li>Absolute pressure sensor</li> <li>MAP/BARO switch solenoid valve</li> </ul>

## DTC Confirmation Procedure

NEEC0283

Perform "PROCEDURE FOR MALFUNCTION A" first. If the 1st trip DTC cannot be confirmed, perform "PROCEDURE FOR MALFUNCTION B".

### NOTE:

If "DTC Confirmation Procedure" has been previously conducted, always turn ignition switch "OFF" and wait at least 5 seconds before conducting the next test.

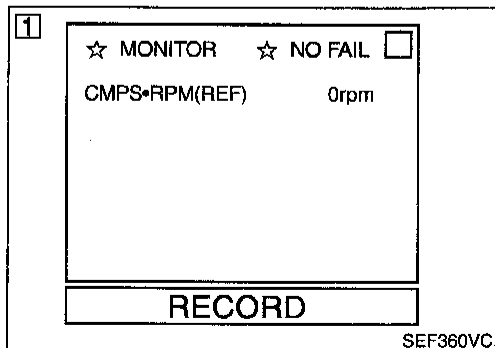

## PROCEDURE FOR MALFUNCTION A

NEEC0283S01

### TESTING CONDITION:

Before performing the following procedure, confirm that battery voltage is more than 11V at ignition switch "ON".

### ① With CONSULT

- 1) Turn ignition switch "ON" and select "DATA MONITOR" mode with CONSULT.
- 2) Wait at least 10 seconds.
- 3) If 1st trip DTC is detected, go to "Diagnostic Procedure", EC-359.

# DTC P1105 MANIFOLD ABSOLUTE PRESSURE (MAP)/BAROMETRIC PRESSURE (BARO) SWITCH SOLENOID VALVE

DTC Confirmation Procedure (Cont'd)

## ⑤ With GST

- 1) Turn ignition switch "ON" and wait at least 10 seconds.
- 2) Select "MODE 7" with GST.
- 3) If 1st trip DTC is detected, go to "Diagnostic Procedure", EC-359.

## ⑥ No Tools

- 1) Turn ignition switch "ON" and wait at least 10 seconds.
- 2) Turn ignition switch "OFF", wait at least 5 seconds and then turn "ON".
- 3) Perform "Diagnostic Test Mode II (Self-diagnostic results)" with ECM.
- 4) If 1st trip DTC is detected, go to "Diagnostic Procedure", EC-359.

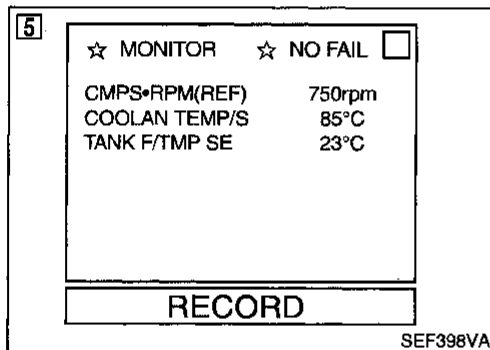

## PROCEDURE FOR MALFUNCTION B

NEEC0283S02

## ⑦ With CONSULT

- 1) Start engine and warm it up to normal operating temperature.
- 2) Turn ignition switch "OFF" and wait at least 5 seconds.
- 3) Turn ignition switch "ON" again and select "DATA MONITOR" mode with CONSULT.
- 4) Make sure that "TANK F/TMP SE" is more than 0°C (32°F).
- 5) Start engine and let it idle for at least 10 seconds.
- 6) If 1st trip DTC is detected, go to "Diagnostic Procedure", EC-359.

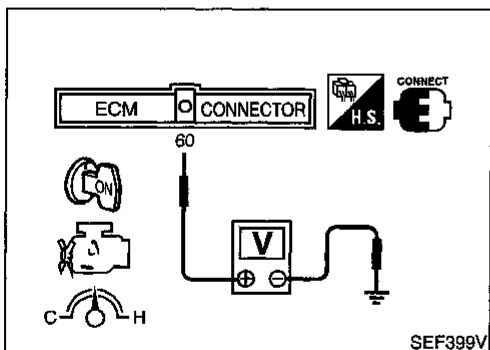

## ⑧ With GST

- 1) Start engine and warm it up to normal operating temperature.
- 2) Turn ignition switch "OFF" and wait at least 5 seconds.
- 3) Turn ignition switch "ON".
- 4) Check that voltage between ECM terminal 60 (Tank fuel temperature sensor signal) and ground is less than 4.2V.
- 5) Start engine and let it idle for at least 10 seconds.
- 6) Select "MODE 7" with GST.
- 7) If 1st trip DTC is detected, go to "Diagnostic Procedure", EC-359.

## ⑨ No Tools

- 1) Start engine and warm it up to normal operating temperature.
- 2) Turn ignition switch "OFF" and wait at least 5 seconds.
- 3) Turn ignition switch "ON".
- 4) Check that voltage between ECM terminal 60 (Tank fuel temperature sensor signal) and ground is less than 4.2V.
- 5) Start engine and let it idle for at least 10 seconds.
- 6) Turn ignition switch "OFF", wait at least 5 seconds and then turn "ON".
- 7) Perform "Diagnostic Test Mode II (Self-diagnostic results)" with ECM.

# DTC P1105 MANIFOLD ABSOLUTE PRESSURE (MAP)/BAROMETRIC PRESSURE (BARO) SWITCH SOLENOID VALVE

*DTC Confirmation Procedure (Cont'd)*

- 8) If 1st trip DTC is detected, go to "Diagnostic Procedure", EC-359.

GI

MA

EM

LC

**EC**

FE

CL

MT

AT

TF

PD

FA

RA

BR

ST

RS

BT

HA

EL

IDX

# DTC P1105 MANIFOLD ABSOLUTE PRESSURE (MAP)/BAROMETRIC PRESSURE (BARO) SWITCH SOLENOID VALVE

Wiring Diagram

## Wiring Diagram

NEEC0284

EC-SW/V-01

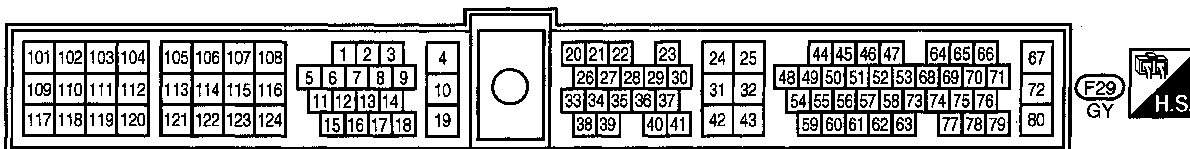
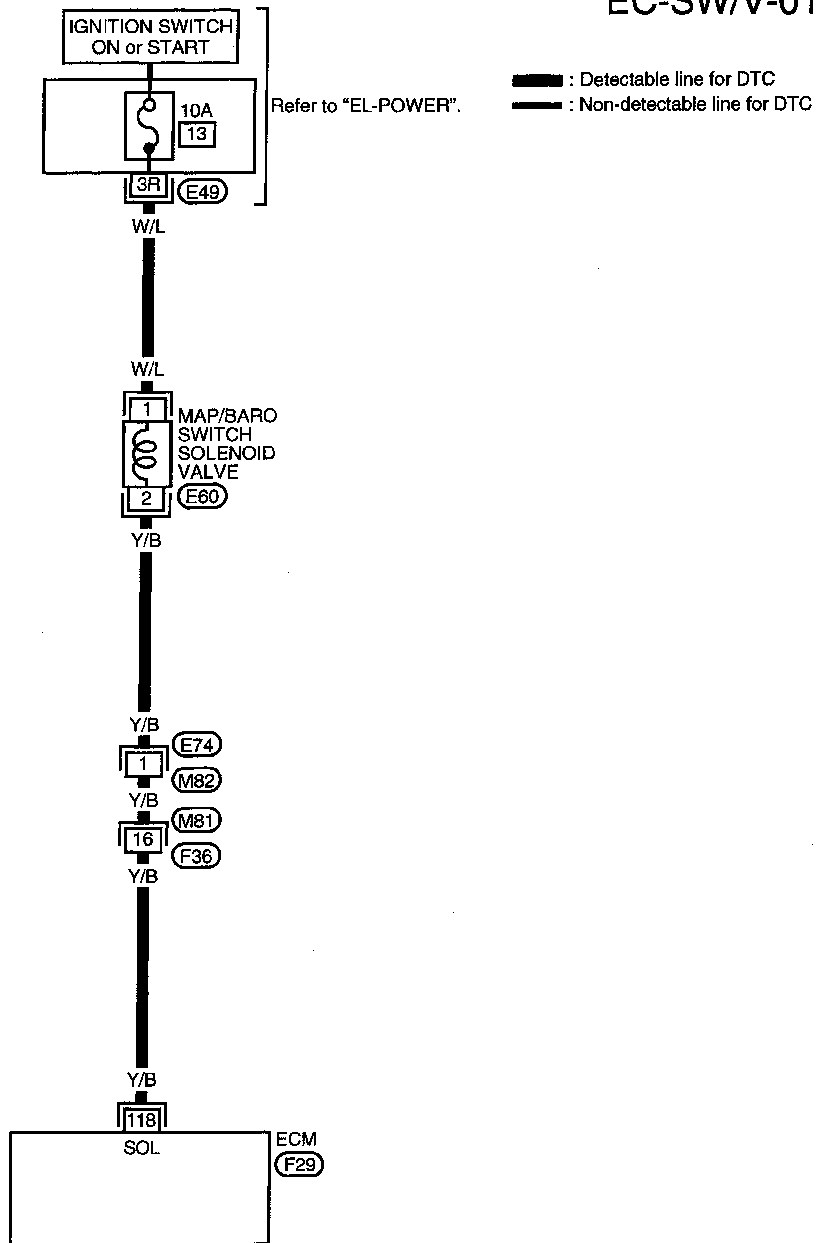

AEC763A

# DTC P1105 MANIFOLD ABSOLUTE PRESSURE (MAP)/BAROMETRIC PRESSURE (BARO) SWITCH SOLENOID VALVE

Diagnostic Procedure

## Diagnostic Procedure

If the trouble is duplicated after "PROCEDURE FOR MALFUNCTION A", perform "PROCEDURE A" below. If the trouble is duplicated after "PROCEDURE FOR MALFUNCTION B", perform "PROCEDURE B" on next page.

### PROCEDURE A

NEEC0285

NEEC0285S01

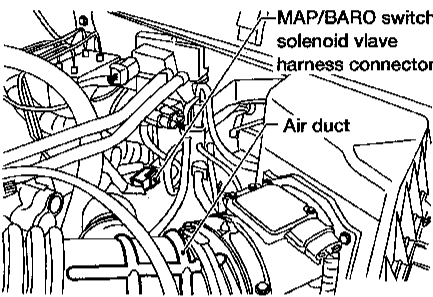
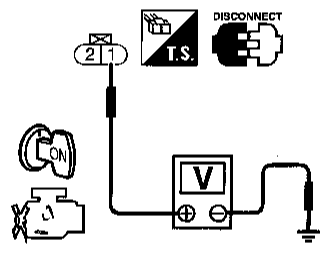
<b>1</b>	<b>CHECK POWER SUPPLY</b>
<p>1. Turn ignition switch "OFF".</p> <p>2. Disconnect MAP/BARO switch solenoid valve harness connector.</p>	
 <p style="text-align: right;">AEC650A</p>	
<p>3. Turn ignition switch "ON".</p> <p>4. Check voltage between terminal 1 and ground with CONSULT or tester.</p>	
 <p style="text-align: center;">Voltage: Battery voltage</p> <p style="text-align: center;">OK or NG</p> <p style="text-align: right;">SEF653W</p>	
OK	▶ GO TO 3.
NG	▶ GO TO 2.

<b>2</b>	<b>DETECT MALFUNCTIONING PART</b>
<p>Check the following.</p> <ul style="list-style-type: none"> <li>• Fuse block (J/B) connector E49</li> <li>• 10A fuse</li> <li>• Harness for open or short between MAP/BARO switch solenoid valve and fuse</li> </ul>	
▶ Repair harness or connectors.	

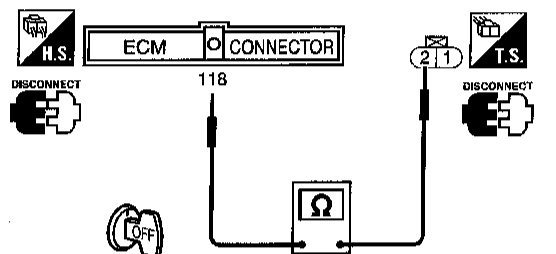
<b>3</b>	<b>CHECK OUTPUT SIGNAL CIRCUIT</b>
<p>1. Turn ignition switch "OFF".</p> <p>2. Disconnect ECM harness connector.</p> <p>3. Check harness continuity between ECM terminal 118 and terminal 2.</p>	
 <p style="text-align: center;">Continuity should exist.</p> <p>4. Also check harness for short to ground and short to power.</p> <p style="text-align: center;">OK or NG</p> <p style="text-align: right;">SEF654W</p>	
OK	▶ GO TO 5.
NG	▶ GO TO 4.

<b>4</b>	<b>DETECT MALFUNCTIONING PART</b>
<p>Check the following.</p> <ul style="list-style-type: none"> <li>• Harness connectors E74, M82</li> <li>• Harness connectors M81, F36</li> <li>• Harness for open or short between MAP/BARO switch solenoid valve and ECM</li> </ul>	
▶ Repair open circuit or short to ground or short to power in harness or connectors.	

<b>5</b>	<b>CHECK MAP/BARO SWITCH SOLENOID VALVE</b>
<p>Refer to "Component Inspection", EC-363.</p> <p style="text-align: center;">OK or NG</p>	
OK	▶ GO TO 6.
NG	▶ Replace MAP/BARO switch solenoid valve.

<b>6</b>	<b>CHECK INTERMITTENT INCIDENT</b>
<p>Refer to "TROUBLE DIAGNOSIS FOR INTERMITTENT INCIDENT", EC-115.</p>	
▶ INSPECTION END	

GI  
MA  
EM  
LC  
EC  
FE  
CL  
MT  
AT  
TF  
PD  
FA  
RA  
BR  
ST  
RS  
BT  
HA  
EL  
IDX

# DTC P1105 MANIFOLD ABSOLUTE PRESSURE (MAP)/BAROMETRIC PRESSURE (BARO) SWITCH SOLENOID VALVE

Diagnostic Procedure (Cont'd)

## PROCEDURE B

=NEEC0285S02

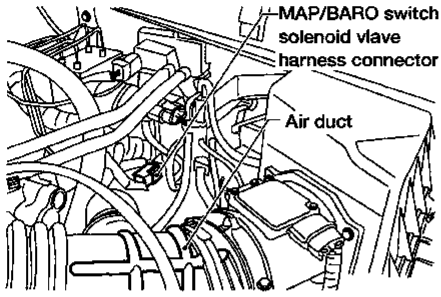
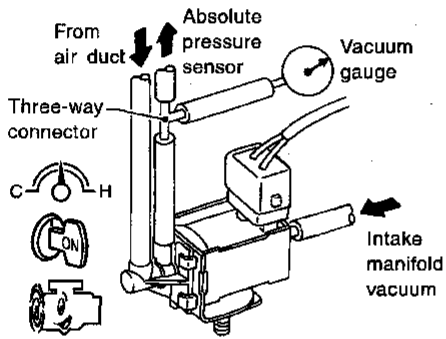
<b>1</b>	<b>INSPECTION START</b>
<ol style="list-style-type: none"> <li>1. Start engine and warm it up to normal operating temperature.</li> <li>2. Turn ignition switch "OFF".</li> <li>3. Attach the vacuum gauge between MAP/BARO switch solenoid valve and rubber tube connected to absolute pressure sensor.</li> </ol>	
 <p style="text-align: right;">AEC650A</p>	
 <p style="text-align: right;">SEF676T</p>	
Models with CONSULT	▶ GO TO 2.
Models without CONSULT	▶ GO TO 3.

<b>2</b>	<b>CHECK VACUUM SOURCE TO ABSOLUTE PRESSURE SENSOR</b>
<p><b>With CONSULT</b></p> <ol style="list-style-type: none"> <li>1. Start engine and let it idle.</li> <li>2. Select "MAP/BARO SW/V" in "ACTIVE TEST" mode with CONSULT.</li> <li>3. Touch "MAP" and "BARO" alternately and check for vacuum.</li> </ol>	
<div style="border: 1px solid black; padding: 5px; width: fit-content; margin: 0 auto;"> <p style="text-align: center;">■ ACTIVE TEST ■ <input type="checkbox"/></p> <p style="text-align: center;">MAP/BARO SW/V    <b>MAP</b></p> <hr/> <p style="text-align: center;">===== MONITOR =====</p> <p>CMPS•RPM(REF)    757rpm</p> <p>MAP/BARO SW/V    MAP</p> <p>ABSOL PRES/SE    1.3V</p> <div style="display: flex; justify-content: space-around; margin-top: 5px;"> <span style="border: 1px solid black; padding: 2px;">BARO</span> <span style="border: 1px solid black; padding: 2px; background-color: black; color: white;">MAP</span> </div> </div> <p style="text-align: right;">SEF396V</p>	
<div style="border: 1px solid black; padding: 5px; width: fit-content; margin: 0 auto;"> <p style="text-align: center;">■ ACTIVE TEST ■ <input type="checkbox"/></p> <p style="text-align: center;">MAP/BARO SW/V    <b>BARO</b></p> <hr/> <p style="text-align: center;">===== MONITOR =====</p> <p>CMPS•RPM(REF)    757rpm</p> <p>MAP/BARO SW/V    BARO</p> <p>ABSOL PRES/SE    4.3V</p> <div style="display: flex; justify-content: space-around; margin-top: 5px;"> <span style="border: 1px solid black; padding: 2px; background-color: black; color: white;">BARO</span> <span style="border: 1px solid black; padding: 2px;">MAP</span> </div> </div> <p style="text-align: right;">SEF397V</p>	
MTBL0079	
<b>OK or NG</b>	
OK	▶ GO TO 12.
NG	▶ GO TO 4.

<b>3</b>	<b>CHECK VACUUM SOURCE TO ABSOLUTE PRESSURE SENSOR</b>						
<p><b>Without CONSULT</b></p> <ol style="list-style-type: none"> <li>1. Start engine and let it idle.</li> <li>2. Check for vacuum under the following condition.</li> </ol>							
<table border="1" style="width: 100%; border-collapse: collapse;"> <thead> <tr> <th style="width: 60%;">Condition</th> <th>Vacuum</th> </tr> </thead> <tbody> <tr> <td>For 5 seconds after starting engine</td> <td>Should not exist</td> </tr> <tr> <td>More than 5 seconds after starting engine</td> <td>Should exist</td> </tr> </tbody> </table>		Condition	Vacuum	For 5 seconds after starting engine	Should not exist	More than 5 seconds after starting engine	Should exist
Condition	Vacuum						
For 5 seconds after starting engine	Should not exist						
More than 5 seconds after starting engine	Should exist						
MTBL0080							
<b>OK or NG</b>							
OK	▶ GO TO 12.						
NG	▶ GO TO 4.						

# DTC P1105 MANIFOLD ABSOLUTE PRESSURE (MAP)/BAROMETRIC PRESSURE (BARO) SWITCH SOLENOID VALVE

Diagnostic Procedure (Cont'd)

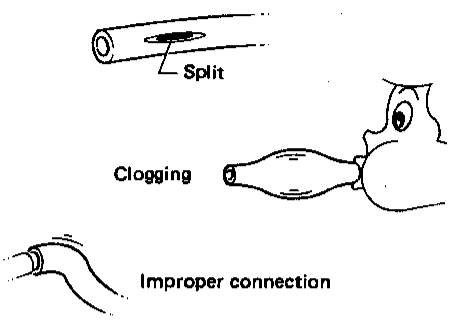
<b>4</b>	<b>CHECK VACUUM HOSE</b>
<ol style="list-style-type: none"> <li>Turn ignition switch "OFF".</li> <li>Check hose for clogging, cracks, disconnection or improper connection.</li> </ol>	
	
SEF109L	
<b>OK or NG</b>	
OK	▶ GO TO 5.
NG	▶ Clean, repair or reconnect the hose.

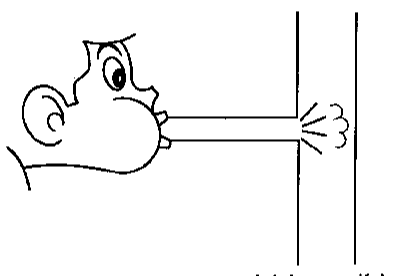
<b>5</b>	<b>CHECK VACUUM PORT</b>
Check vacuum port for clogging.	
	
Intake manifold SEF368U	
<b>OK or NG</b>	
OK	▶ GO TO 6.
NG	▶ Clean or repair the vacuum port.

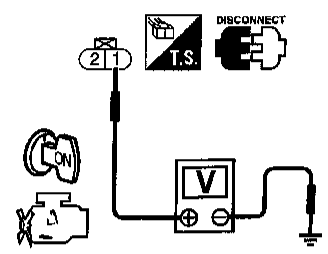
<b>6</b>	<b>CHECK POWER SUPPLY</b>
<ol style="list-style-type: none"> <li>Turn ignition switch "OFF".</li> <li>Disconnect MAP/BARO switch solenoid valve harness connector.</li> <li>Turn ignition switch "ON".</li> <li>Check voltage between terminal 1 and ground with CONSULT or tester.</li> </ol>	
	
Voltage: Battery voltage	
<b>OK or NG</b>	
OK	▶ GO TO 8.
NG	▶ GO TO 7.

<b>7</b>	<b>DETECT MALFUNCTIONING PART</b>
Check the following.	
<ul style="list-style-type: none"> <li>Fuse block (J/B) connector E49</li> <li>10A fuse</li> <li>Harness for open or short between MAP/BARO switch solenoid valve and fuse</li> </ul>	
▶ Repair harness or connectors.	

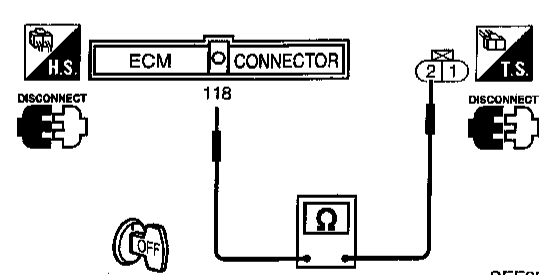
<b>8</b>	<b>CHECK OUTPUT SIGNAL CIRCUIT</b>
<ol style="list-style-type: none"> <li>Turn ignition switch "OFF".</li> <li>Disconnect ECM harness connector.</li> <li>Check harness continuity between ECM terminal 118 and terminal 2.</li> </ol>	
	
Continuity should exist.	
4. Also check harness for short to ground and short to power.	
<b>OK or NG</b>	
OK	▶ GO TO 10.
NG	▶ GO TO 9.

GI  
MA  
EM  
LC  
EC  
FE  
CL  
MT  
AT  
TF  
PD  
FA  
RA  
BR  
ST  
RS  
BT  
HA  
EL  
IDX

# DTC P1105 MANIFOLD ABSOLUTE PRESSURE (MAP)/BAROMETRIC PRESSURE (BARO) SWITCH SOLENOID VALVE

Diagnostic Procedure (Cont'd)

<b>9</b>	<b>DETECT MALFUNCTIONING PART</b>
Check the following. <ul style="list-style-type: none"> <li>• Harness connectors E74, M82</li> <li>• Harness connectors M81, F36</li> <li>• Harness for open or short between MAP/BARO switch solenoid valve and ECM</li> </ul>	
▶	Repair open circuit or short to ground or short to power in harness or connectors.

<b>10</b>	<b>CHECK MAP/BARO SWITCH SOLENOID VALVE</b>
Refer to "Component Inspection", EC-363.	
<b>OK or NG</b>	
OK	▶ GO TO 11.
NG	▶ Replace MAP/BARO switch solenoid valve.

<b>11</b>	<b>CHECK INTAKE SYSTEM</b>
Check intake system for air leaks.	
<b>OK or NG</b>	
OK	▶ GO TO 15.
NG	▶ Repair it.

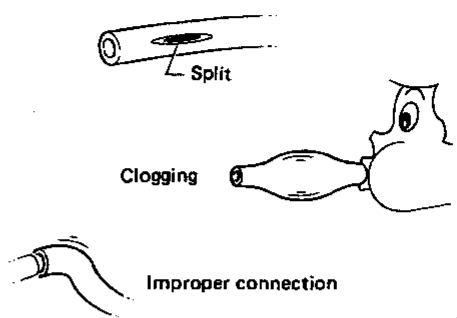
<b>12</b>	<b>CHECK HOSE BETWEEN ABSOLUTE PRESSURE SENSOR AND MAP/BARO SWITCH SOLENOID VALVE</b>
Check hose for clogging, cracks, disconnection or improper connection.	
	
SEF109L	
<b>OK or NG</b>	
OK	▶ GO TO 13.
NG	▶ Repair or reconnect hose.

<b>13</b>	<b>CHECK HARNESS CONNECTOR</b>
1. Disconnect absolute pressure sensor harness connector. 2. Check sensor harness connector for water. <b>Water should not exist.</b>	
<b>OK or NG</b>	
OK	▶ GO TO 14.
NG	▶ Repair or replace harness connector.

<b>14</b>	<b>CHECK ABSOLUTE PRESSURE SENSOR</b>
Refer to "Component Inspection", EC-138.	
<b>OK or NG</b>	
OK	▶ GO TO 15.
NG	▶ Replace absolute pressure sensor.

<b>15</b>	<b>CHECK INTERMITTENT INCIDENT</b>
Refer to "TROUBLE DIAGNOSIS FOR INTERMITTENT INCIDENT", EC-115.	
▶	<b>INSPECTION END</b>



# DTC P1105 MANIFOLD ABSOLUTE PRESSURE (MAP)/BAROMETRIC PRESSURE (BARO) SWITCH SOLENOID VALVE

Component Inspection

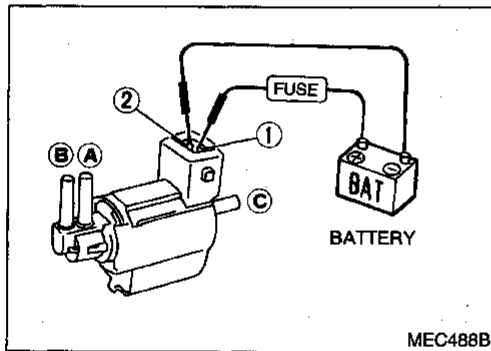
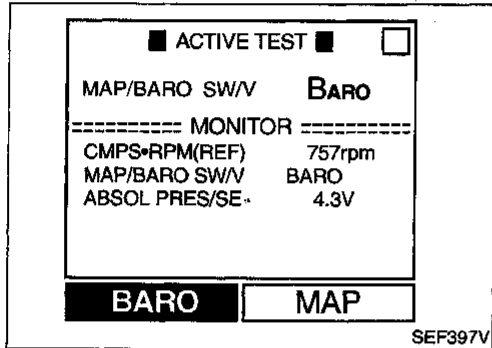
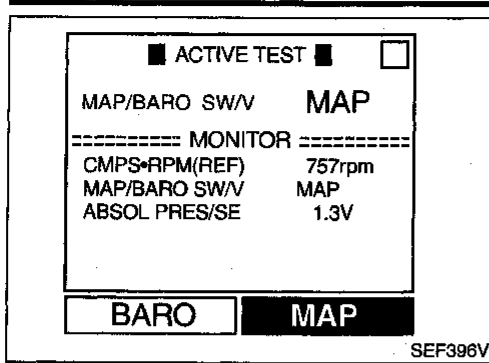

## Component Inspection

### MAP/BARO SWITCH SOLENOID VALVE

NEEC0286

NEEC0286S01

#### ④ With CONSULT

- 1) Start engine and warm it up to normal operating temperature.
- 2) Perform "MAP/BARO SW/V" in "ACTIVE TEST" mode with CONSULT.
- 3) Check the following.
  - Condition: At idle under no-load
  - CONSULT display

MAP/BARO	ABSOL PRES/SE (Voltage)
BARO	More than 2.6V
MAP	Less than the voltage at BARO

- Time for voltage to change

MAP/BARO SW/V	Required time to switch
BARO to MAP	Less than 1 second
MAP to BARO	

- 4) If NG, check solenoid valve as shown below.

#### ⊗ Without CONSULT

- 1) Remove MAP/BARO switch solenoid valve.
- 2) Check air passage continuity.

Condition	Air passage continuity between A and B	Air passage continuity between A and C
12V direct current supply between terminals 1 and 2	Yes	No
No supply	No	Yes

- 3) If NG or operation takes more than 1 second, replace solenoid valve.

GI  
MA  
EM  
LC  
EC  
FE  
CL  
MT  
AT  
TF  
PD  
FA  
RA  
BR  
ST  
RS  
BT  
HA  
EL  
IDX

# DTC P1148 (RIGHT BANK, -B1), P1168 (LEFT BANK, -B2) CLOSED LOOP CONTROL

On Board Diagnosis Logic

## On Board Diagnosis Logic

NEEC0470

★ The closed loop control has the one trip detection logic.

DTC No.	Malfunction is detected when ...	Check Items (Possible Cause)
P1148 0307 (Right bank)	<ul style="list-style-type: none"> <li>The closed loop control function for right bank does not operate even when vehicle is driving in the specified condition.</li> </ul>	<ul style="list-style-type: none"> <li>The front heated oxygen sensor circuit is open or shorted.</li> <li>Front heated oxygen sensor</li> <li>Front heated oxygen sensor heater</li> </ul>
P1168 0308 (Left bank)	<ul style="list-style-type: none"> <li>The closed loop control function for left bank does not operate even when vehicle is driving in the specified condition.</li> </ul>	<ul style="list-style-type: none"> <li>The front heated oxygen sensor circuit is open or shorted.</li> <li>Front heated oxygen sensor</li> <li>Front heated oxygen sensor heater</li> </ul>

## DTC Confirmation Procedure

NEEC0471

### CAUTION:

Always drive vehicle at a safe speed.

### NOTE:

If "DTC Confirmation Procedure" has been previously conducted, always turn ignition switch "OFF" and wait at least 5 seconds before conducting the next test.

### TESTING CONDITION:

- Never raise engine speed above 3,200 rpm during the "DTC Confirmation Procedure". If the engine speed limit is exceeded, retry the procedure from step 2.
- Before performing the following procedure, confirm that battery voltage is more than 11V at idle.

3

☆ MONITOR
☆ NO FAIL

CMPS-RPM(REF)	2000rpm
MAS AIR/FL SE	2.47V
FR O2 SEN-B1	0.74V
FR O2 SEN-B2	0.74V
FR O2 MNTR-B1	RICH
FR O2 MNTR-B2	RICH

RECORD

SEF392VA

### ④ With CONSULT

- 1) Start engine and warm it up to normal operating temperature.
  - 2) Select "DATA MONITOR" mode with CONSULT.
  - 3) Hold engine speed at 2,000 rpm and check one of the following.
    - "FR O2 SEN-B1 (-B2)" voltage should go above 0.70V at least once.
    - "FR O2 SEN-B1 (-B2)" voltage should go below 0.21V at least once.
- If the check result is NG, perform "Diagnosis Procedure", EC-365.

# DTC P1148 (RIGHT BANK, -B1), P1168 (LEFT BANK, -B2) CLOSED LOOP CONTROL

DTC Confirmation Procedure (Cont'd)

If the check result is OK, perform the following step.

- 4) Let engine idle at least 5 minutes.
- 5) Maintain the following condition at least 50 consecutive seconds.

B/FUEL SCHDL	1.7 msec or more
CMPS-RPM (POS)	1,600 - 3,000 rpm
Selector lever	Suitable position
VHCL SPEED SE	More than 70 km/h (43 MPH)

During this test, P0130 and/or P0150 may be displayed on CONSULT screen.

- 6) If DTC is detected, go to "Diagnostic Procedure", EC-365.

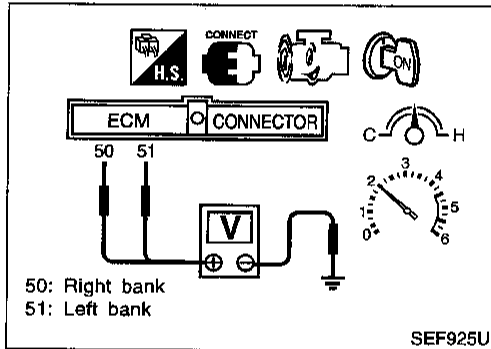

## Overall Function Check

Use this procedure to check the overall function of the closed loop control. During this check, a DTC might not be confirmed. NEEC0472

### ⊗ Without CONSULT

- 1) Start engine and warm it up to normal operating temperature.
- 2) Set voltmeter probes between ECM terminal 50 (front heated oxygen sensor right bank signal) or 51 (front heated oxygen sensor left bank signal) and engine ground.
- 3) Check the following with engine speed held at 2,000 rpm constant under no-load.
  - The voltage should go above 0.70V at least once.
  - The voltage should go below 0.21V at least once.
- 4) If NG, go to "Diagnostic Procedure", EC-365.

## Diagnostic Procedure

Perform trouble diagnosis for "DTC P0133, P0153", EC-186. NEEC0473

# DTC P1320 IGNITION SIGNAL

## Component Description

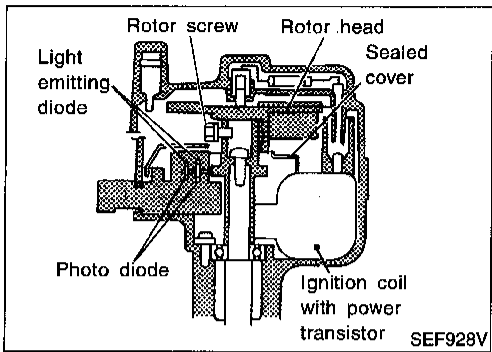

## Component Description

### IGNITION COIL & POWER TRANSISTOR

The power transistor switches on and off the ignition coil primary circuit according to the ECM signal. As the primary circuit is turned on and off, the proper high voltage is induced in the secondary circuit. The distributor is not repairable except for the distributor cap and rotor head.

#### NOTE:

The rotor screw which secures the distributor rotor head to the distributor shaft must be torqued properly.

:  $3.6 \pm 0.3$  N·m ( $37 \pm 3$  kg·cm,  $32 \pm 3$  in·lb)

## ECM Terminals and Reference Value

Specification data are reference values and are measured between each terminal and 32 (ECM ground).

TERMINAL NO.	WIRE COLOR	ITEM	CONDITION	DATA (DC Voltage)
1	PU/W	Ignition signal	[Engine is running] • Idle speed	Approximately 0.7V 
			[Engine is running] • Engine speed is 2,000 rpm	1.1 - 1.5V 
2	B	Ignition check	[Engine is running] • Warm-up condition • Idle speed	Approximately 12V 
			[Engine is running] • Engine speed is 2,000 rpm.	Approximately 11V 

# DTC P1320 IGNITION SIGNAL

On Board Diagnosis Logic

## On Board Diagnosis Logic

NEEC0290

DTC No.	Malfunction is detected when ...	Check Items (Possible Cause)
P1320 0201	<ul style="list-style-type: none"> <li>The ignition signal in the primary circuit is not sent to ECM during engine cranking or running.</li> </ul>	<ul style="list-style-type: none"> <li>Harness or connectors (The ignition primary circuit is open or shorted.)</li> <li>Power transistor unit.</li> <li>Resistor</li> <li>Camshaft position sensor</li> <li>Camshaft position sensor circuit</li> </ul>

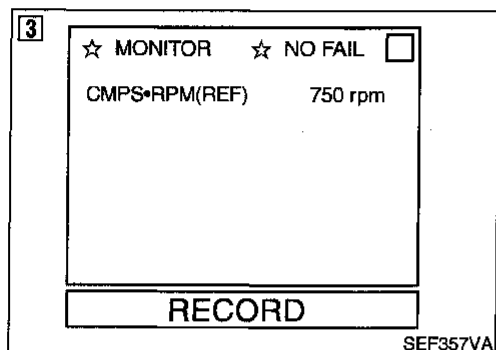

### DTC Confirmation Procedure

NEEC0291

#### NOTE:

- If "DTC Confirmation Procedure" has been previously conducted, always turn ignition switch "OFF" and wait at least 5 seconds before conducting the next test.
- If DTC P1320 (0201) is displayed with DTC P0340 (0101), perform trouble diagnosis for DTC P0340 first. Refer to EC-281.**

#### Ⓔ With CONSULT

- Turn ignition switch "ON".
- Select "DATA MONITOR" mode with CONSULT.
- Start engine. (If engine does not run, turn ignition switch to "START" for at least 5 seconds.)
- If 1st trip DTC is detected, go to "Diagnostic Procedure", EC-369.

#### Ⓔ With GST

- Start engine. (If engine does not run, turn ignition switch to "START" for at least 5 seconds.)
- Select MODE 7 with GST.
- If 1st trip DTC is detected, go to "Diagnostic Procedure", EC-369.

#### Ⓔ No Tools

- Start engine. (If engine does not run, turn ignition switch to "START" for at least 5 seconds.)
- Turn ignition switch "OFF" and wait at least 5 seconds, then turn "ON".
- Perform "Diagnostic Test Mode II" (Self-diagnostic results) with ECM.
- If 1st trip DTC is detected, go to "Diagnostic Procedure", EC-369.

GI  
MA  
EM  
LC  
EC  
FE  
CL  
MT  
AT  
TF  
PD  
FA  
RA  
BR  
ST  
RS  
BT  
HA  
EL  
IDX

# DTC P1320 IGNITION SIGNAL

Wiring Diagram

## Wiring Diagram

NEEC0292

EC-IGN/SG-01

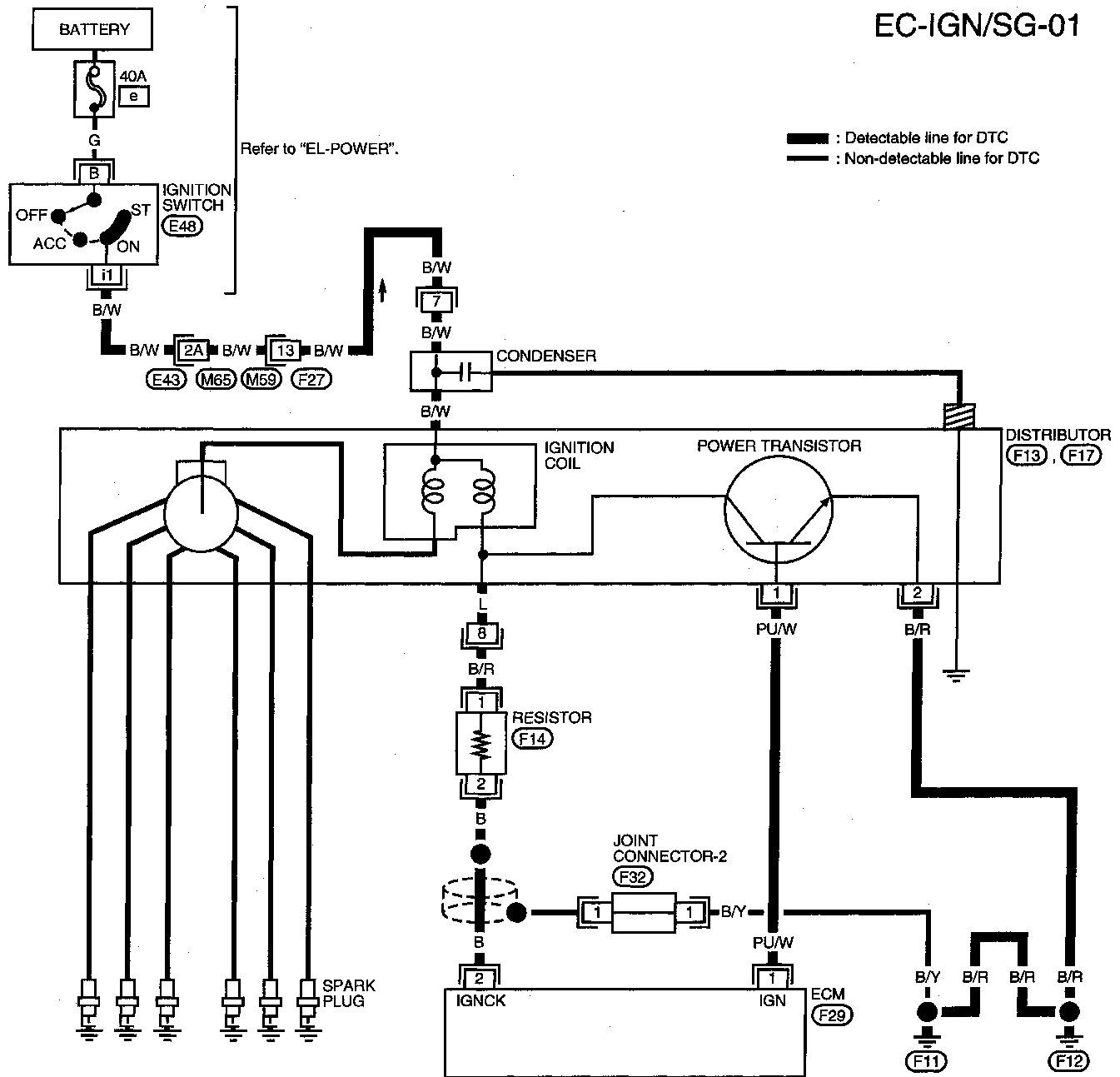

: Detectable line for DTC  
 : Non-detectable line for DTC

Refer to "EL-POWER".

Refer to last page (Foldout page).

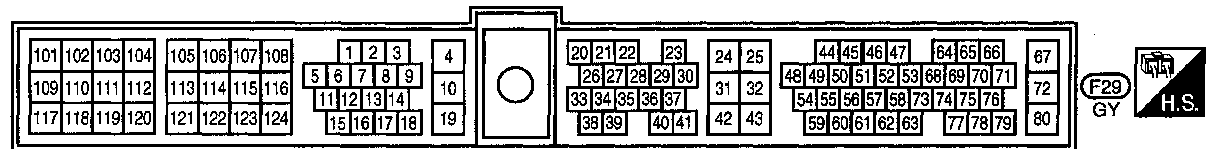
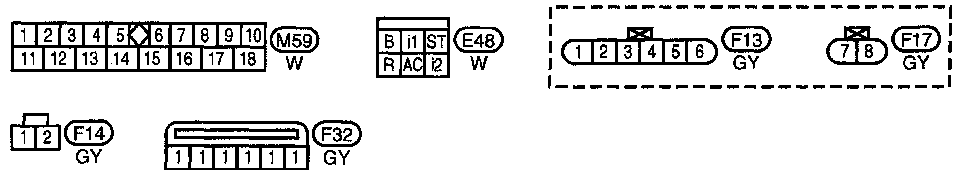

AEC746A

# DTC P1320 IGNITION SIGNAL

Diagnostic Procedure

## Diagnostic Procedure

NEEC0293

<b>1</b>	<b>CHECK ENGINE START</b>
Turn ignition switch "OFF", and restart engine. <b>Is engine running?</b>	
<b>Yes or No</b>	
Yes	▶ GO TO 7.
No	▶ GO TO 2.

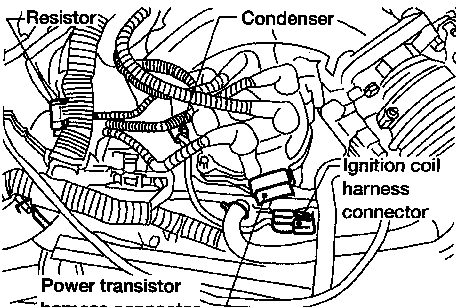
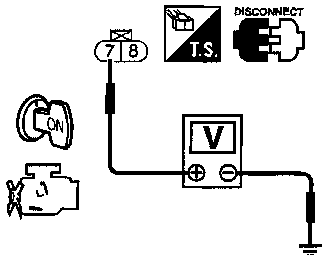
<b>2</b>	<b>CHECK POWER SUPPLY</b>
1. Turn ignition switch "OFF". 2. Disconnect ignition coil harness connector.	
 <p style="text-align: right;">AEC656A</p>	
3. Turn ignition switch "ON". 4. Check voltage between terminal 7 and ground with CONSULT or tester.	
 <p style="text-align: right;">SEF721U</p>	
<b>Voltage: Battery voltage</b>	
<b>OK or NG</b>	
OK	▶ GO TO 4.
NG	▶ GO TO 3.

<b>3</b>	<b>DETECT MALFUNCTIONING PART</b>
Check the following.	
<ul style="list-style-type: none"> <li>• Harness connectors E43, M65</li> <li>• Harness connectors M59, F27</li> <li>• Harness for open or short between ignition coil and ignition switch</li> </ul>	
▶ Repair harness or connectors.	

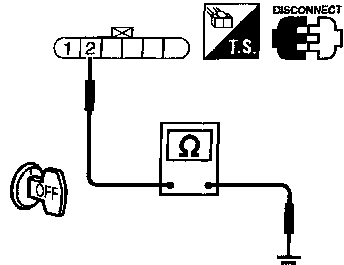
<b>4</b>	<b>CHECK GROUND CIRCUIT</b>
1. Turn ignition switch "OFF". 2. Disconnect power transistor harness connector. 3. Check harness continuity between terminal 2 and engine ground.	
 <p style="text-align: right;">SEF722U</p>	
<b>Continuity should exist.</b>	
4. Also check harness for short to ground and short to power.	
<b>OK or NG</b>	
OK	▶ GO TO 5.
NG	▶ Repair open circuit or short to ground or short to power in harness or connectors.

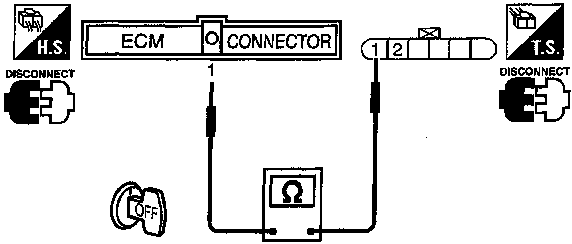
<b>5</b>	<b>CHECK OUTPUT SIGNAL CIRCUIT</b>
1. Disconnect ECM harness connector. 2. Check harness continuity between ECM terminal 1 and power transistor terminal 1.	
 <p style="text-align: right;">SEF723U</p>	
<b>Continuity should exist.</b>	
3. Also check harness for short to ground and short to power.	
<b>OK or NG</b>	
OK	▶ GO TO 6.
NG	▶ Repair open circuit or short to ground or short to power in harness or connectors.

<b>6</b>	<b>CHECK IGNITION COIL AND POWER TRANSISTOR</b>
Refer to "Component Inspection", EC-371.	
<b>OK or NG</b>	
OK	▶ GO TO 10.
NG	▶ Replace malfunctioning component(s).

GI  
MA  
EM  
LC  
EC  
FE  
CL  
MT  
AT  
TF  
PD  
FA  
RA  
BR  
ST  
RS  
BT  
HA  
EL  
IDX

# DTC P1320 IGNITION SIGNAL

Diagnostic Procedure (Cont'd)

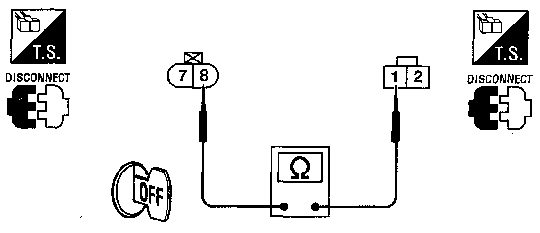
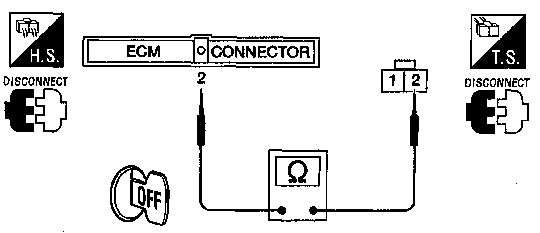
<b>7</b>	<b>CHECK INPUT SIGNAL CIRCUIT</b>
<ol style="list-style-type: none"> <li>1. Stop engine.</li> <li>2. Disconnect ignition coil harness connector.</li> <li>3. Strip tape covering resistor.</li> <li>4. Disconnect resistor harness connector.</li> <li>5. Disconnect ECM harness connector.</li> <li>6. Check harness continuity between ignition coil terminal 8 and resistor terminal 1, resistor terminal 2 and ECM terminal 2.</li> </ol>	
	
	
AEC914A	
<p style="text-align: center;"><b>Continuity should exist.</b></p> <p>7. Also check harness for short to ground and short to power.</p> <p style="text-align: center;"><b>OK or NG</b></p>	
OK	▶ GO TO 8.
NG	▶ Repair open circuit or short to ground or short to power in harness or connectors.

<b>8</b>	<b>CHECK RESISTOR</b>
Refer to "Component Inspection", EC-371.	
<b>OK or NG</b>	
OK	▶ GO TO 9.
NG	▶ Replace resistor.

<b>9</b>	<b>CHECK SHIELD CIRCUIT</b>
<ol style="list-style-type: none"> <li>1. Turn ignition switch "OFF".</li> <li>2. Disconnect joint connector-2.</li> <li>3. Check the following. <ul style="list-style-type: none"> <li>• Continuity between joint connector terminal and ground</li> <li>• Joint connector (Refer to "HARNES LAYOUT" in EL section.)</li> </ul> <p style="text-align: center;"><b>Continuity should exist.</b></p> </li> <li>4. Also check harness for short to ground and short to power.</li> <li>5. Then reconnect joint connector-2.</li> </ol> <p style="text-align: center;"><b>OK or NG</b></p>	
OK	▶ GO TO 10.
NG	▶ Repair open circuit or short to ground or short to power in harness or connectors.

<b>10</b>	<b>CHECK INTERMITTENT INCIDENT</b>
Refer to "TROUBLE DIAGNOSIS FOR INTERMITTENT INCIDENT", EC-115.	
▶ <b>INSPECTION END</b>	



# DTC P1320 IGNITION SIGNAL

Component Inspection

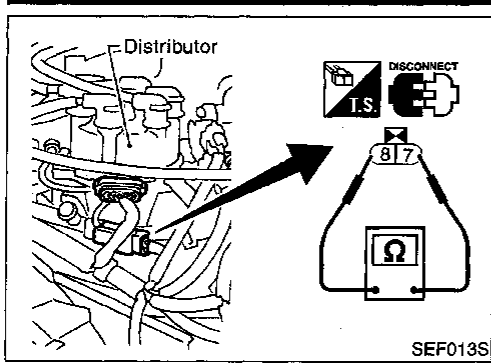

## Component Inspection

NEEC0294

### IGNITION COIL

NEEC0294S01

1. Disconnect ignition coil harness connector.
2. Check resistance as shown in the figure.

Terminal	Resistance [at 25°C (77°F)]
7 - 8 (Primary coil)	0.5 - 1.0Ω
7 - 9 (Secondary coil)	Approximately 12 kΩ

For checking secondary coil, remove distributor cap and measure resistance between coil tower metal tip 9 and terminal 7. If NG, replace distributor assembly as a unit.

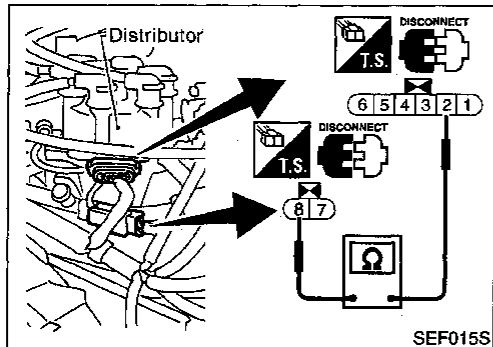
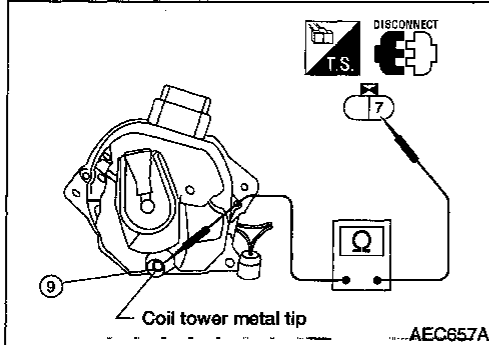

## POWER TRANSISTOR

NEEC0294S02

1. Disconnect camshaft position sensor & power transistor harness connector and ignition coil harness connector.
2. Check power transistor resistance between terminals 2 and 8.

Terminals	Resistance	Result
2 and 8	Except 0Ω	OK
	0Ω	NG

If NG, replace distributor assembly.

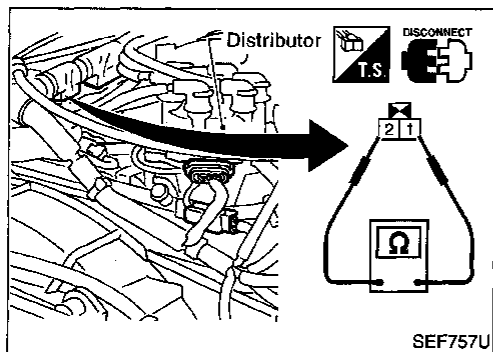

## RESISTOR

NEEC0294S03

1. Disconnect resistor harness connector.
2. Check resistance between terminals 1 and 2.

**Resistance: Approximately 2.2 kΩ [at 25°C (77°F)]**

If NG, replace resistor.

GI  
MA  
EM  
LC  
EC  
FE  
CL  
MT  
AT  
TF  
PD  
FA  
RA  
BR  
ST  
RS  
BT  
HA  
EL  
IDX

# DTC P1336 CRANKSHAFT POSITION SENSOR (CKPS) (OBD) (COG)

## Component Description

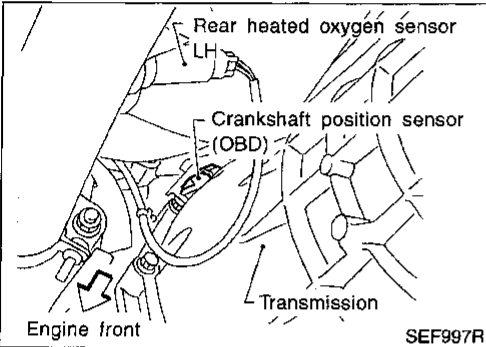
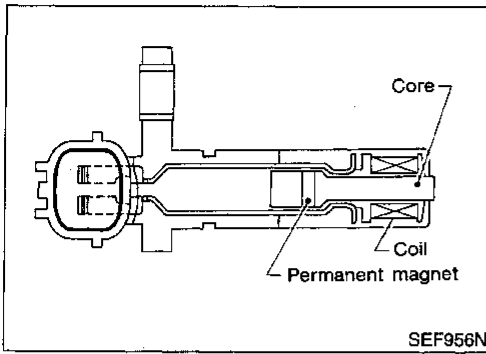

## Component Description

The crankshaft position sensor (OBD) is located on the transmission housing facing the gear teeth (cogs) of the flywheel or drive plate. It detects the fluctuation of the engine revolution.

The sensor consists of a permanent magnet, core and coil.

When the engine is running, the high and low parts of the teeth cause the gap with the sensor to change.

The changing gap causes the magnetic field near the sensor to change.

Due to the changing magnetic field, the voltage from the sensor changes.

The ECM receives the voltage signal and detects the fluctuation of the engine revolution.

This sensor is not used to control the engine system.

It is used only for the on board diagnosis.

## ECM Terminals and Reference Value

Specification data are reference values and are measured between each terminal and 32 (ECM ground).

TERMI- NAL NO.	WIRE COLOR	ITEM	CONDITION	DATA (AC Voltage)
47	L	Crankshaft position sensor (OBD)	[Engine is running] • Warm-up condition • Idle speed	1 - 2V (AC range)  SEF690W
			[Engine is running] • Engine speed is 2,000 rpm	3 - 4V (AC range)  SEF691W

## On Board Diagnosis Logic

DTC No.	Malfunction is detected when ...	Check Items (Possible Cause)
P1336 0905	• A chipping of the flywheel or drive plate gear tooth (cog) is detected by the ECM.	• Harness or connectors • Crankshaft position sensor (OBD) • Drive plate/Flywheel

# DTC P1336 CRANKSHAFT POSITION SENSOR (CKPS) (OBD) (COG)

DTC Confirmation Procedure

## DTC Confirmation Procedure

NEEC0298

### NOTE:

If "DTC Confirmation Procedure" has been previously conducted, always turn ignition switch "OFF" and wait at least 5 seconds before conducting the next test.

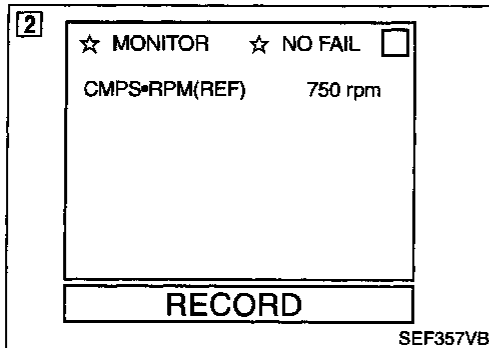

### ① With CONSULT

- 1) Turn ignition switch "ON" and select "DATA MONITOR" mode with CONSULT.
- 2) Start engine and run it for at least 2 minutes at idle speed.
- 3) If 1st trip DTC is detected, go to "Diagnostic Procedure", EC-375.

### ② With GST

- 1) Start engine and run it for at least 2 minutes at idle speed.
- 2) Select "MODE 7" with GST.
- 3) If 1st trip DTC is detected, go to "Diagnostic Procedure", EC-375.

### ③ No Tools

- 1) Start engine and run it for at least 2 minutes at idle speed.
- 2) Turn ignition switch "OFF", wait at least 5 seconds and then turn "ON".
- 3) Perform "Diagnostic Test Mode II" (Self-diagnostic results) with ECM.
- 4) If 1st trip DTC is detected, go to "Diagnostic Procedure", EC-375.

GI

MA

EM

LC

EC

FE

CL

MT

AT

TF

PD

FA

RA

BR

ST

RS

BT

HA

EL

IDX

# DTC P1336 CRANKSHAFT POSITION SENSOR (CKPS) (OBD) (COG)

Wiring Diagram

## Wiring Diagram

NEEC0299

EC-CKPS-01

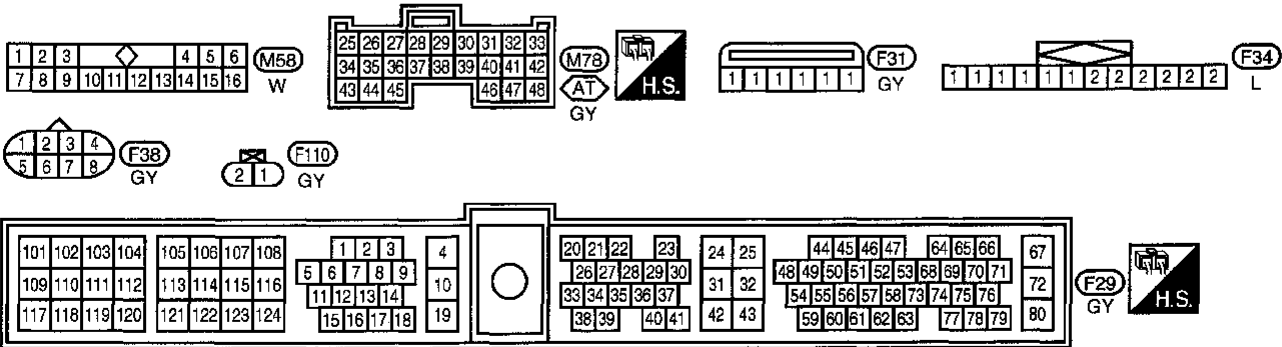
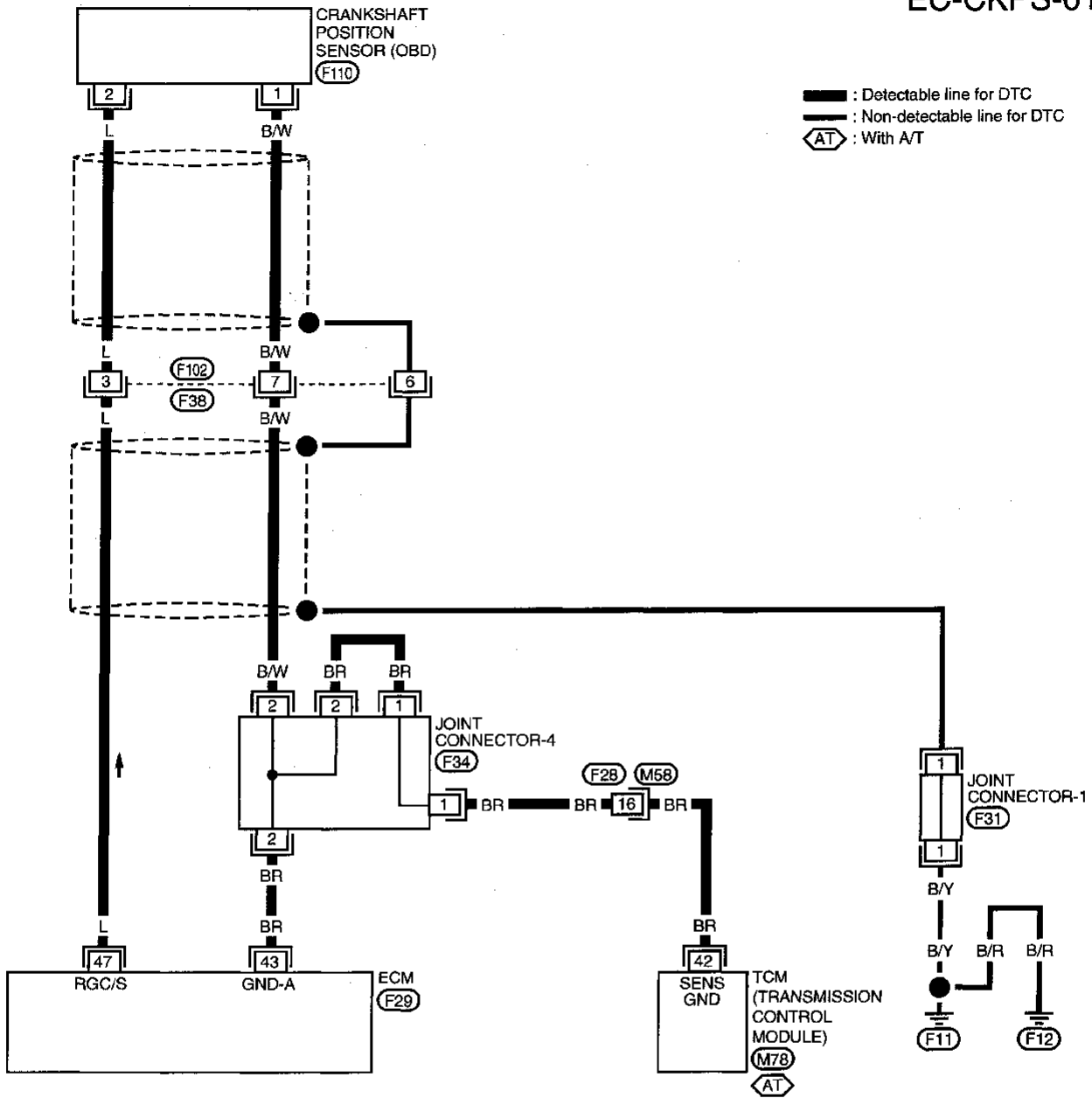

AEC740A

# DTC P1336 CRANKSHAFT POSITION SENSOR (CKPS) (OBD) (COG)

Diagnostic Procedure

## Diagnostic Procedure

NEEC0300

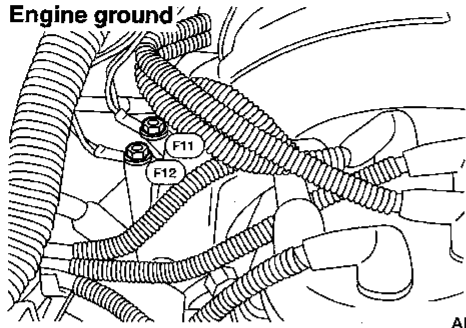
<b>1</b>	<b>RETIGHTEN GROUND SCERWS</b>
<ol style="list-style-type: none"> <li>Turn ignition switch "OFF".</li> <li>Loosen and retighten engine ground screws.</li> </ol>	
<p style="text-align: center;"><b>Engine ground</b></p>  <p style="text-align: right;">AEC640A</p>	
▶ GO TO 2.	

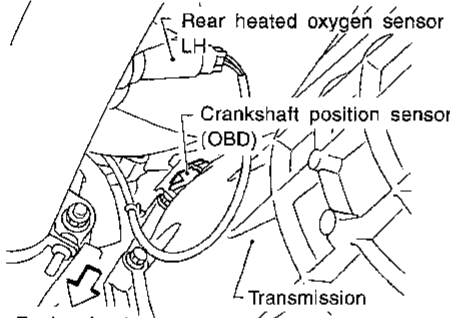
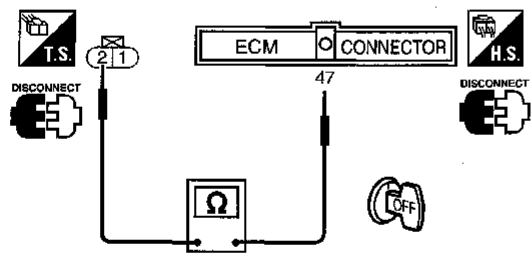
<b>2</b>	<b>CHECK INPUT SIGNAL CIRCUIT</b>
<ol style="list-style-type: none"> <li>Disconnect crankshaft position sensor (OBD) and ECM harness connectors.</li> </ol>	
 <p style="text-align: center;">Engine front</p> <p style="text-align: right;">SEF997R</p>	
<ol style="list-style-type: none"> <li>Check continuity between ECM terminal 47 and terminal 2.</li> </ol>	
 <p style="text-align: center;">Continuity should exist.</p> <p style="text-align: right;">SEF644W</p>	
<ol style="list-style-type: none"> <li>Also check harness for short to ground and short to power.</li> </ol>	
OK or NG	
OK ▶	GO TO 4.
NG ▶	GO TO 3.

<b>3</b>	<b>DETECT MALFUNCTIONING PART</b>
Check the following. <ul style="list-style-type: none"> <li>Harness connectors F38, F102</li> <li>Harness for open or short between ECM and crankshaft position sensor (OBD)</li> </ul>	
▶ Repair open circuit or short to ground or short to power in harness or connectors.	

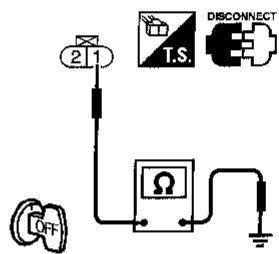
<b>4</b>	<b>CHECK GROUND CIRCUIT</b>
<ol style="list-style-type: none"> <li>Reconnect ECM harness connectors.</li> <li>Check harness continuity between terminal 1 and engine ground.</li> </ol>	
 <p style="text-align: right;">SEF645W</p>	
Continuity should exist.	
<ol style="list-style-type: none"> <li>Also check harness for short to ground and short to power.</li> </ol>	
OK or NG	
OK ▶	GO TO 6.
NG ▶	GO TO 5.

<b>5</b>	<b>DETECT MALFUNCTIONING PART</b>
Check the following. <ul style="list-style-type: none"> <li>Harness connectors F38, F102</li> <li>Harness connectors F28, M58</li> <li>Joint connector-4</li> <li>Harness for open or short between crankshaft position sensor (OBD) and ECM</li> <li>Harness for open or short between crankshaft position sensor (OBD) and TCM (Transmission Control Module)</li> </ul>	
▶ Repair open circuit or short to ground or short to power in harness or connectors.	

<b>6</b>	<b>CHECK IMPROPER INSTALLATION</b>
<ol style="list-style-type: none"> <li>Loosen and retighten the fixing bolt of the crankshaft position sensor (OBD).</li> <li>Perform "DTC Confirmation Procedure", EC-373 again.</li> </ol>	
Is a 1st trip DTC P1336 (0905) detected?	
Yes ▶	GO TO 7.
No ▶	<b>INSPECTION END</b>

GI  
MA  
EM  
LC  
EC  
FE  
CL  
MT  
AT  
TF  
PD  
FA  
RA  
BR  
ST  
RS  
BT  
HA  
EL  
IDX

# DTC P1336 CRANKSHAFT POSITION SENSOR (CKPS) (OBD) (COG)

Diagnostic Procedure (Cont'd)

<b>7</b>	<b>CHECK CRANKSHAFT POSITION SENSOR (OBD)</b>
Refer to "Component Inspection" EC-376.	
<b>OK or NG</b>	
OK	▶ GO TO 8.
NG	▶ Replace crankshaft position sensor (OBD).

<b>8</b>	<b>CHECK SHIELD CIRCUIT</b>
1. Disconnect harness connectors F38, F102.	
2. Check harness continuity between harness connector F38 and engine ground. <b>Continuity should exist.</b>	
3. Also check harness for short to ground and short to power.	
<b>OK or NG</b>	
OK	▶ GO TO 10.
NG	▶ GO TO 9.

<b>9</b>	<b>DETECT MALFUNCTIONING PART</b>
Check the following.	
<ul style="list-style-type: none"> <li>• Harness connectors F38, F102</li> <li>• Joint connector-1</li> <li>• Harness for open or short between harness connector F38 and engine ground</li> </ul>	
▶	Repair open circuit or short to ground or short to power in harness or connectors.

<b>10</b>	<b>CHECK GEAR TOOTH</b>
Visually check for chipping flywheel or drive plate gear tooth (cog).	
<b>OK or NG</b>	
OK	▶ GO TO 11.
NG	▶ Replace the flywheel or drive plate.

<b>11</b>	<b>CHECK INTERMITTENT INCIDENT</b>
Refer to "TROUBLE DIAGNOSIS FOR INTERMITTENT INCIDENT", EC-115.	
▶	<b>INSPECTION END</b>

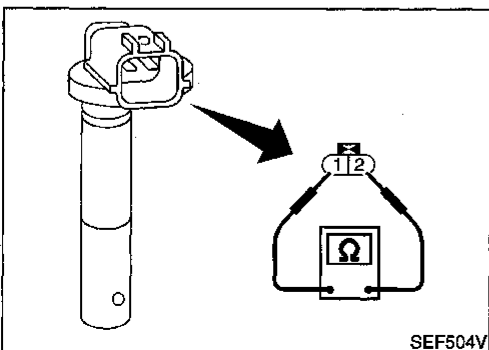
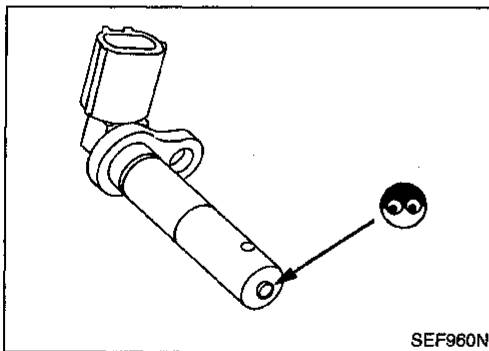

## Component Inspection

### CRANKSHAFT POSITION SENSOR (OBD)

NEEC0301

NEEC0301501

1. Disconnect crankshaft position sensor (OBD) harness connector.
2. Loosen the fixing bolt of the sensor.
3. Remove the sensor.
4. Visually check the sensor for chipping.

5. Check resistance as shown in the figure.

**Resistance: Approximately 166.5 - 203.5Ω [at 20°C (68°F)]**

# DTC P1400 EGRC-SOLENOID VALVE

Component Description

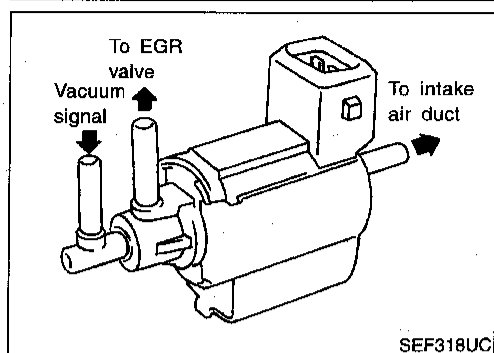

## Component Description

The EGRC-solenoid valve responds to signals from the ECM. When the ECM sends an ON (ground) signal, the coil in the solenoid valve is energized. The vacuum signal (from the intake manifold collector) passes through the solenoid valve. The signal then reaches the EGR valve.

When the ECM sends an OFF signal, a plunger will then move to cut the vacuum signal.

## CONSULT Reference Value in Data Monitor Mode

Specification data are reference values.

MONITOR ITEM	CONDITION	SPECIFICATION
EGRC SOLV	<ul style="list-style-type: none"> <li>Engine: After warming up</li> <li>Air conditioner switch: "OFF"</li> <li>Shift lever: "N"</li> <li>No-load</li> </ul>	Idle OFF
		Engine speed: Revving from idle up to 3,000 rpm quickly ON

## ECM Terminals and Reference Value

Specification data are reference values and are measured between each terminal and 32 (ECM ground).

TERMI-NAL NO.	WIRE COLOR	ITEM	CONDITION	DATA (DC Voltage)
103	G/W	EGRC-solenoid valve	[Engine is running] <ul style="list-style-type: none"> <li>Warm-up condition</li> <li>Idle speed</li> </ul>	BATTERY VOLTAGE (11 - 14V)
			[Engine is running] <ul style="list-style-type: none"> <li>Warm-up condition</li> <li>Revving engine from idle up to 3,000 rpm quickly</li> </ul>	0 - 1.5V

## On Board Diagnosis Logic

DTC No.	Malfunction is detected when ...	Check Items (Possible Cause)
P1400 1005	<ul style="list-style-type: none"> <li>The improper voltage signal is sent to ECM through EGRC-solenoid valve.</li> </ul>	<ul style="list-style-type: none"> <li>Harness or connectors (The EGRC-solenoid valve circuit is open or shorted.)</li> <li>EGRC-solenoid valve</li> </ul>

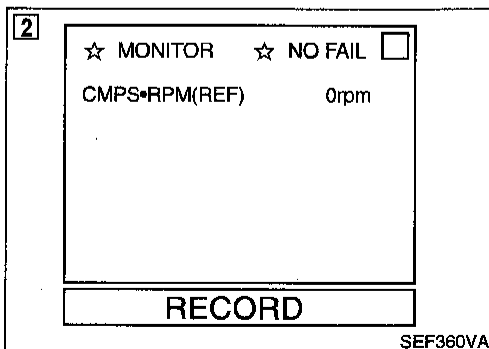

## DTC Confirmation Procedure

### NOTE:

If "DTC Confirmation Procedure" has been previously conducted, always turn ignition switch "OFF" and wait at least 5 seconds before conducting the next test.

### With CONSULT

- 1) Turn ignition switch "ON".
- 2) Select "DATA MONITOR" mode with CONSULT and wait at least 5 seconds.
- 3) If 1st trip DTC is detected, go to "Diagnostic Procedure", EC-380.

EC-377

## DTC P1400 EGRC-SOLENOID VALVE

DTC Confirmation Procedure (Cont'd)

---

### ⑤ With GST

- 1) Turn ignition switch "ON" and wait at least 5 seconds.
- 2) Select "MODE 7" with GST.
- 3) If 1st trip DTC is detected, go to "Diagnostic Procedure", EC-380.

### ⑥ No Tools

- 1) Turn ignition switch "ON" and wait at least 5 seconds.
- 2) Turn ignition switch "OFF" and wait at least 5 seconds.
- 3) Turn ignition switch "ON" and perform "Diagnostic Test Mode II (Self-diagnostic results)" with ECM.
- 4) If 1st trip DTC is detected, go to "Diagnostic Procedure", EC-380.



# DTC P1400 EGRC-SOLENOID VALVE

Wiring Diagram

## Wiring Diagram

NEEC0307

### EC-EGRC/V-01

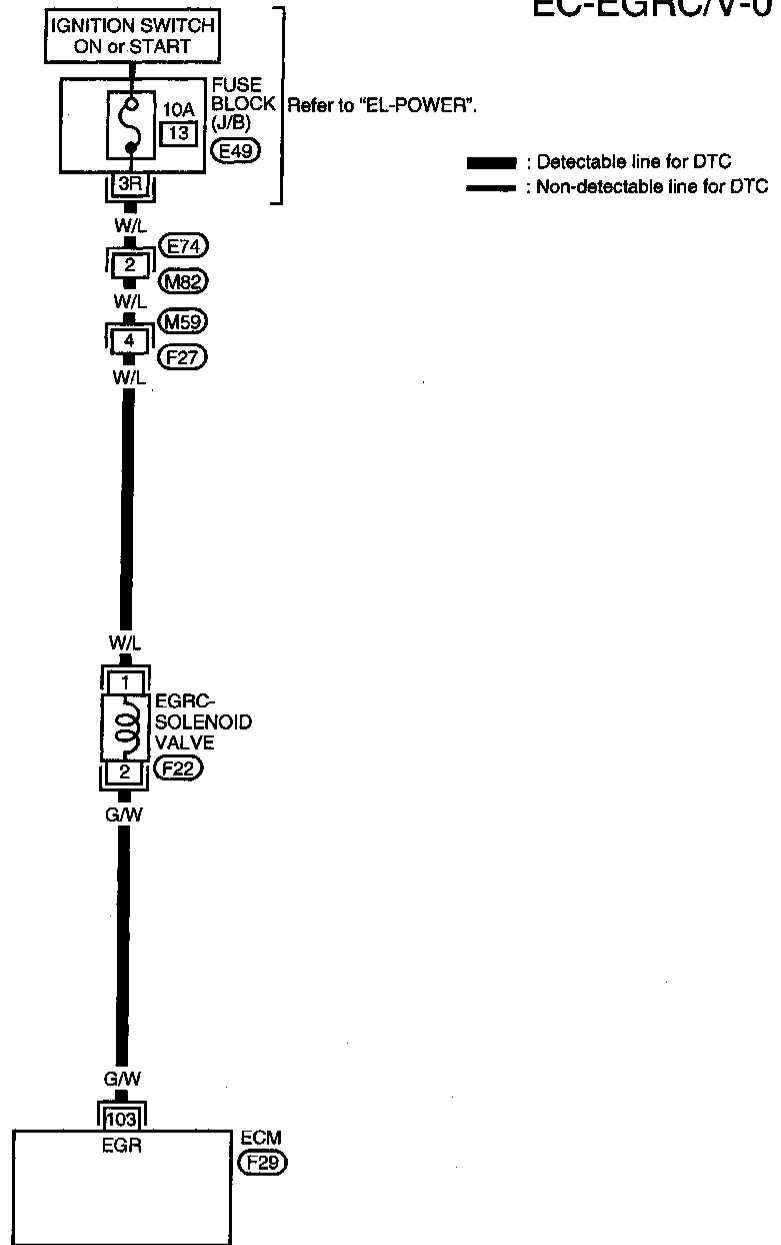

1	2	3	4	5	6	7	8	9	10	M59
11	12	13	14	15	16	17	18	19	20	W

1R	2R	3R	4R	5R	E49		
6R	7R	8R	9R	10R	11R	12R	W

1	2	3	4	5	6	7	8	E74				
9	10	11	12	13	14	15	16	17	18	19	20	W

F22	F29	
2	1	B

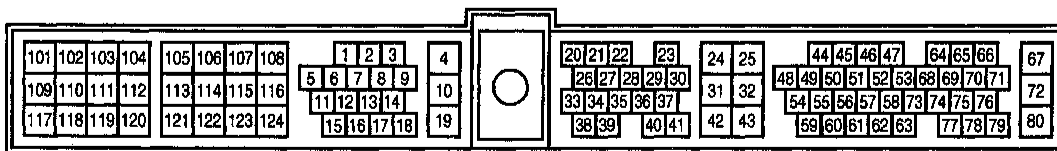

AEC747A

# DTC P1400 EGRC-SOLENOID VALVE

Diagnostic Procedure

## Diagnostic Procedure

NEEC0308

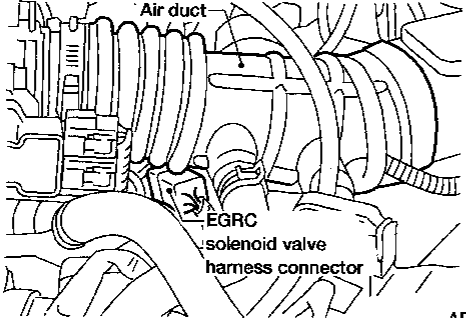
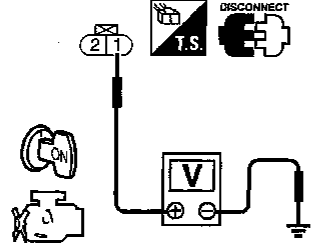
<b>1</b>	<b>CHECK POWER SUPPLY</b>						
<p>1. Turn ignition switch "OFF". 2. Disconnect EGRC-solenoid valve harness connector.</p>  <p style="text-align: right;">AEC659A</p> <p>3. Turn ignition switch "ON". 4. Check voltage between terminal 1 and ground with CONSULT or tester.</p>  <p style="text-align: right;">SEF657W</p> <p style="text-align: center;">Voltage: Battery voltage</p> <p style="text-align: center;">OK or NG</p> <table border="1" style="width: 100%;"> <tr> <td>OK</td> <td>▶</td> <td>GO TO 3.</td> </tr> <tr> <td>NG</td> <td>▶</td> <td>GO TO 2.</td> </tr> </table>		OK	▶	GO TO 3.	NG	▶	GO TO 2.
OK	▶	GO TO 3.					
NG	▶	GO TO 2.					

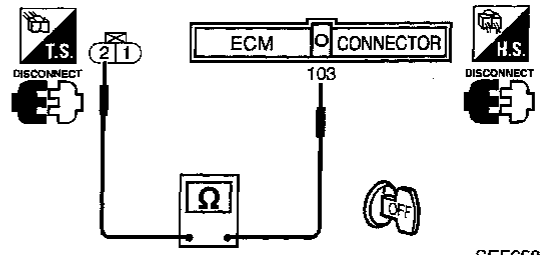
<b>3</b>	<b>CHECK OUTPUT SIGNAL CIRCUIT</b>						
<p>1. Turn ignition switch "OFF". 2. Disconnect ECM harness connector. 3. Check harness continuity between ECM terminal 103 and terminal 2.</p>  <p style="text-align: right;">SEF658W</p> <p style="text-align: center;">Continuity should exist.</p> <p>4. Also check harness for short to ground and short to power.</p> <p style="text-align: center;">OK or NG</p> <table border="1" style="width: 100%;"> <tr> <td>OK</td> <td>▶</td> <td>GO TO 4.</td> </tr> <tr> <td>NG</td> <td>▶</td> <td>Repair open circuit or short to ground or short to power in harness or connectors.</td> </tr> </table>		OK	▶	GO TO 4.	NG	▶	Repair open circuit or short to ground or short to power in harness or connectors.
OK	▶	GO TO 4.					
NG	▶	Repair open circuit or short to ground or short to power in harness or connectors.					

<b>4</b>	<b>CHECK EGRC-SOLENOID VALVE</b>	
Refer to "Component Inspection", EC-380.		
OK or NG		
OK	▶	GO TO 5.
NG	▶	Replace EGRC-solenoid valve.

<b>5</b>	<b>CHECK INTERMITTENT INCIDENT</b>
Refer to "TROUBLE DIAGNOSIS FOR INTERMITTENT INCIDENT", EC-115.	
▶	
<b>INSPECTION END</b>	

<b>2</b>	<b>DETECT MALFUNCTIONING PART</b>
<p>Check the following.</p> <ul style="list-style-type: none"> <li>• Harness connectors E74, M82</li> <li>• Harness connectors M59, F27</li> <li>• Fuse block (J/B) connector E49</li> <li>• 10A fuse</li> <li>• Harness for open or short between EGRC-solenoid valve and fuse</li> </ul> <p style="text-align: right;">▶ Repair harness or connectors.</p>	

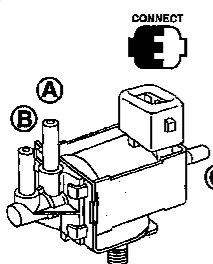

CONNECT	
<input checked="" type="checkbox"/> ACTIVE TEST <input type="checkbox"/> ON <input type="checkbox"/> EGRC SOLV (EGF) <input type="checkbox"/> FLOW	<input type="checkbox"/> ON <input type="checkbox"/> FLOW
===== MONITOR ===== CMPS/RPM (REF)    Orpm	
<input type="checkbox"/> ON <input type="checkbox"/> ON/OFF <input type="checkbox"/> OFF	

SEF193W

### Component Inspection EGRC-SOLENOID VALVE

NEEC0309

NEEC0309S01

Check air passage continuity.

① With CONSULT

Perform "EGRC SOLENOID VALVE" in "ACTIVE TEST" mode.

Conditions	Air passage continuity between A and B	Air passage continuity between A and C
ON	Yes	No
OFF	No	Yes

# DTC P1400 EGRC-SOLENOID VALVE

Component Inspection (Cont'd)

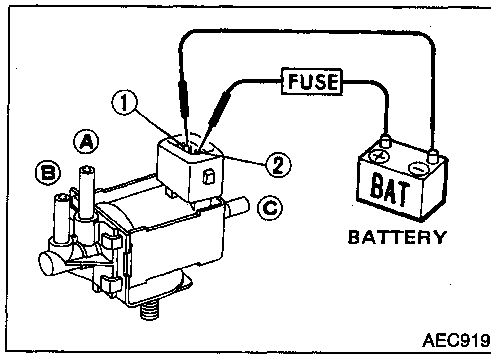

**⊗ Without CONSULT**

Condition	Air passage continuity between A and B	Air passage continuity between A and C
12V direct current supply between terminals 1 and 2	Yes	No
No supply	No	Yes

If NG or operation takes more than 1 second, replace solenoid valve.

GI  
MA  
EM  
LC  
**EC**  
FE  
CL  
MT  
AT  
TF  
PD  
FA  
RA  
BR  
ST  
RS  
BT  
HA  
EL  
IDX

# DTC P1401 EGR TEMPERATURE SENSOR

## Component Description

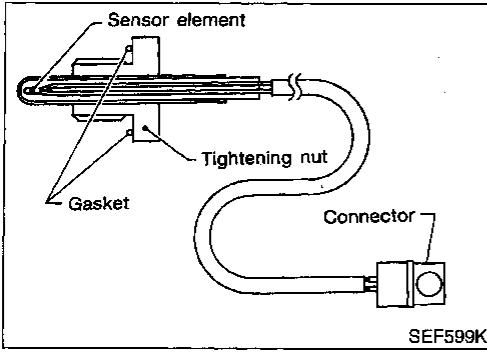

## Component Description

NEEC0310

The EGR temperature sensor detects temperature changes in the EGR passage way. When the EGR valve opens, hot exhaust gases flow, and the temperature in the passage way changes. The EGR temperature sensor is a thermistor that modifies a voltage signal sent from the ECM. This modified signal then returns to the ECM as an input signal. As the temperature increases, EGR temperature sensor resistance decreases.

This sensor is not used to control the engine system. It is used only for the on board diagnosis.

## <Reference data>

EGR temperature °C (°F)	Voltage* (V)	Resistance (MΩ)
0 (32)	4.81	7.9 - 9.7
50 (122)	2.82	0.57 - 0.70
100 (212)	0.8	0.08 - 0.10

\*: These data are reference values and are measured between ECM terminal 63 (EGR temperature sensor) and ECM terminal 32 (ECM ground).

When EGR system is operating.

Voltage: 0 - 1.5V

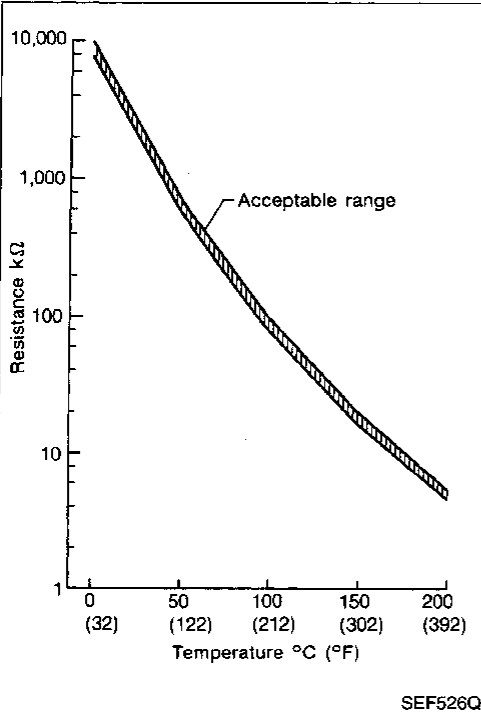

## On Board Diagnosis Logic

NEEC0311

DTC No.	Malfunction is detected when ...		Check Items (Possible Cause)
P1401 0305	A)	An excessively low voltage from the EGR temperature sensor is sent to ECM even when engine coolant temperature is low.	<ul style="list-style-type: none"> <li>• Harness or connectors (The EGR temperature sensor circuit is shorted.)</li> <li>• EGR temperature sensor</li> <li>• Malfunction of EGR function, EGRC-BPT valve or EGRC-solenoid valve</li> </ul>
	B)	An excessively high voltage from the EGR temperature sensor is sent to ECM even when engine coolant temperature is high.	<ul style="list-style-type: none"> <li>• Harness or connectors (The EGR temperature sensor circuit is open.)</li> <li>• EGR temperature sensor</li> <li>• Malfunction of EGR function, EGRC-BPT valve or EGRC-solenoid valve</li> </ul>

# DTC P1401 EGR TEMPERATURE SENSOR

DTC Confirmation Procedure

## DTC Confirmation Procedure

Perform "PROCEDURE FOR MALFUNCTION A" first. If 1st trip DTC cannot be confirmed, perform "PROCEDURE FOR MALFUNCTION B".

### NOTE:

If "DTC Confirmation Procedure" has been previously conducted, always turn ignition switch "OFF" and wait at least 5 seconds before conducting the next test.

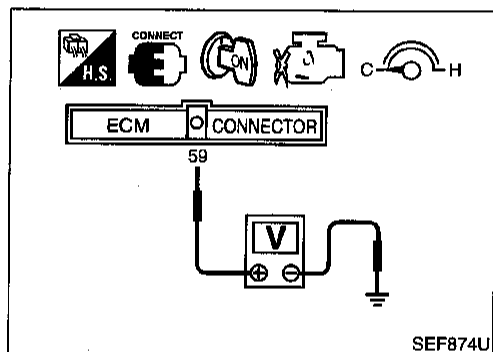
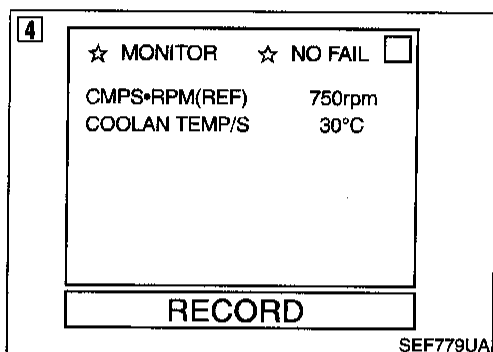

## PROCEDURE FOR MALFUNCTION A

### With CONSULT

- 1) Turn ignition switch "ON".
- 2) Select "DATA MONITOR" mode with CONSULT.
- 3) Verify that "COOLAN TEMP/S" is less than 40°C (104°F).  
**If the engine coolant temperature is above the range, cool the engine down.**
- 4) Start engine and let it idle for at least 8 seconds.
- 5) If 1st trip DTC is detected, go to "Diagnostic Procedure", EC-387.

### With GST

- 1) Turn ignition switch "ON".
- 2) Select "MODE 1" with GST.
- 3) Verify that engine coolant temperature is less than 40°C (104°F).  
**If the engine coolant temperature is above the range, cool the engine down.**
- 4) Start engine and let it idle for at least 8 seconds.
- 5) Select "MODE 7" with GST.
- 6) If 1st trip DTC is detected, go to "Diagnostic Procedure", EC-387.

### No Tools

- 1) Turn ignition switch "ON".
- 2) Verify that voltage between ECM terminal 59 (engine coolant temperature sensor signal) is more 2.7V.  
**If the voltage is below the range, cool the engine down.**
- 3) Start engine and let it idle for at least 8 seconds.
- 4) Turn ignition switch "OFF" and wait at least 5 seconds.
- 5) Turn ignition switch "ON" and perform "Diagnostic Test Mode II (Self-diagnostic results)" with ECM.
- 6) If 1st trip DTC is detected, go to "Diagnostic Procedure", EC-387.

# DTC P1401 EGR TEMPERATURE SENSOR

DTC Confirmation Procedure (Cont'd)

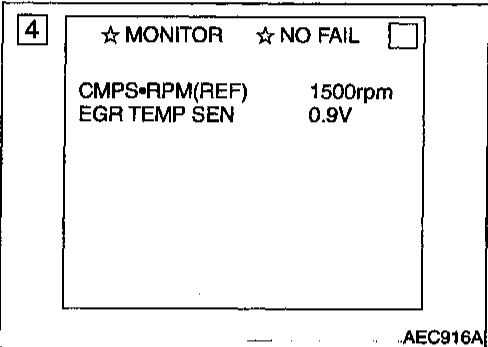
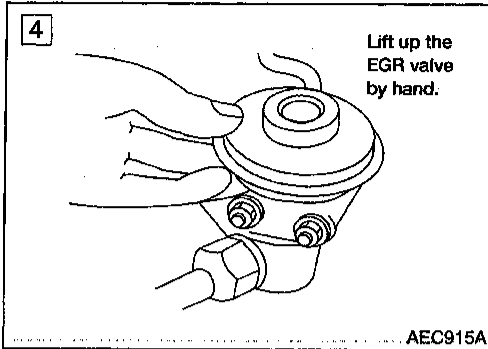

## PROCEDURE FOR MALFUNCTION B

NEEC0474S02

### CAUTION:

Always drive vehicle at a safe speed.

### TESTING CONDITION:

Always perform the test at a temperature of 5°C (41°F) or higher.

### ⓐ With CONSULT

- 1) Start engine and warm it up to normal operating temperature.
- 2) Confirm that EGR valve is not lifting at idle.  
If the check result is NG, go to trouble diagnoses for "DTC P1402". (See page EC-389.)
- 3) Select "DATA MONITOR" mode with CONSULT.
- 4) Read "EGR TEMP SEN" at about 1,500 rpm while holding the EGR valve in full open position by hand.  
**Voltage should decrease to less than 1.5V.**  
If the check result is NG, go to "Diagnostic Procedure", EC-387.  
If the check result is OK, go to following step.
- 5) Turn ignition switch "OFF" and wait at least 5 seconds.
- 6) Turn ignition switch "ON".
- 7) Check the output voltage of "THRTL POS SEN" at closed throttle position and note it.
- 8) Start engine.
- 9) Maintain the following conditions for at least 5 consecutive seconds.

CMPS-RPM (REF)	1,600 - 2,400 rpm
COOLAN TEMP/S	Above 80°C (176°F)
B/FUEL SCHDL	3.0 - 4.5 msec
THRTL POS SEN	X - (X + 0.70) V X = Voltage value measured at step 8
Selector lever	Suitable position

- 10) If 1st trip DTC is detected, go to "Diagnostic Procedure", EC-387.

# DTC P1401 EGR TEMPERATURE SENSOR

Overall Function Check

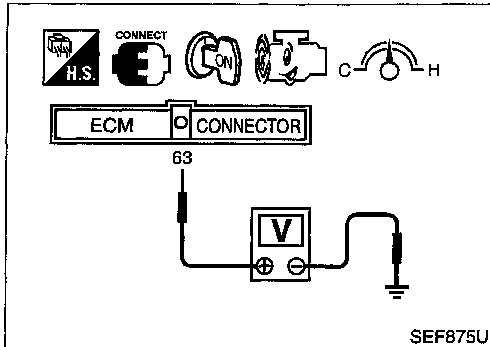
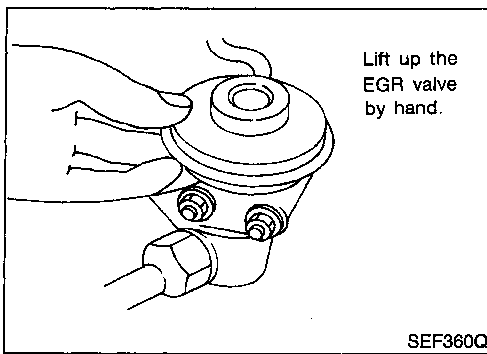

## Overall Function Check

Use this procedure to check the overall function of the EGR temperature sensor. During this check, a 1st trip DTC might not be confirmed.

### PROCEDURE FOR MALFUNCTION B

#### ⊗ Without CONSULT

- 1) Start engine and warm it up to normal operating temperature.
- 2) Confirm that EGR valve is not lifting at idle. If NG, go to trouble diagnoses for DTC P0400 and P0402 (See pages EC-288 and 296).

- 3) Check voltage between ECM terminal 63 (EGR temperature sensor signal) and ground at about 1,500 rpm with EGR valve lifted up to the full position by hand.

**Voltage should decrease to less than 1.5V.**

If NG, go to "Diagnostic Procedure", EC-387.

- 4) If step 4 is OK, perform trouble diagnoses for "DTC P0400, P1400" (See pages EC-288 and 377).

# DTC P1401 EGR TEMPERATURE SENSOR

Wiring Diagram

## Wiring Diagram

NEEC0313

EC-EGR/TS-01

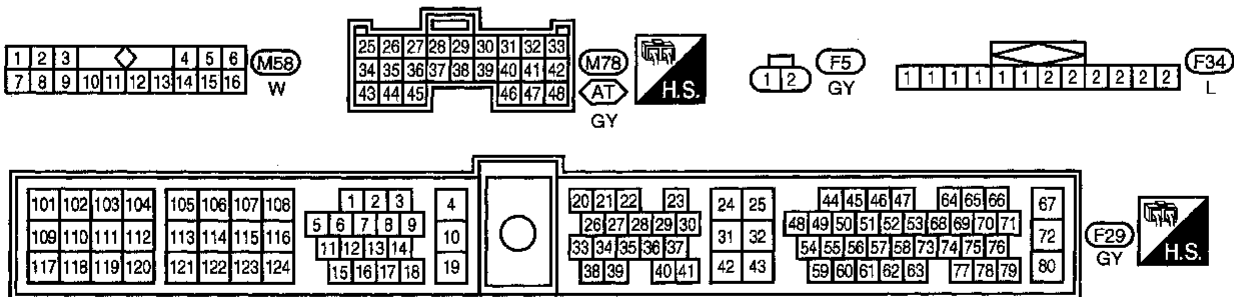
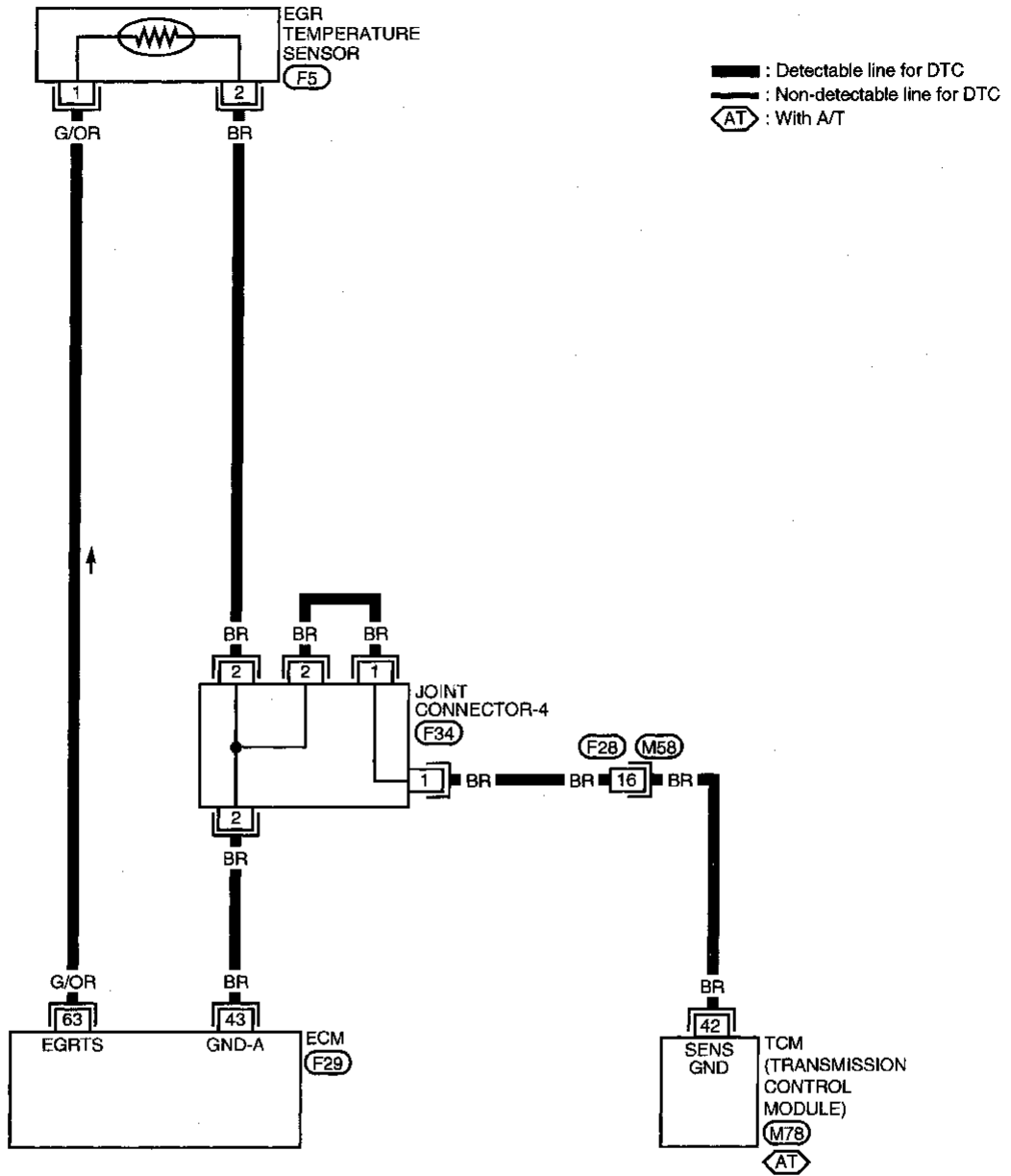

AEC748A



# DTC P1401 EGR TEMPERATURE SENSOR

Diagnostic Procedure

NEEC0314

## Diagnostic Procedure

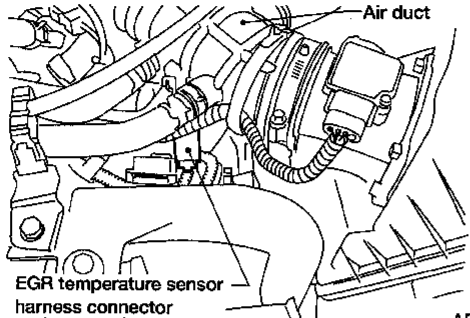
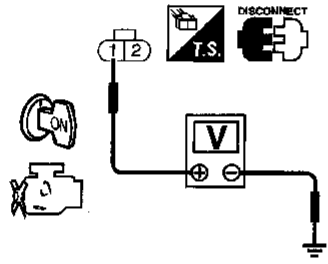
<b>1</b>	<b>CHECK POWER SUPPLY</b>
<ol style="list-style-type: none"> <li>Turn ignition switch "OFF".</li> <li>Disconnect EGR temperature sensor harness connector.</li> </ol>	
 <p style="text-align: right;">AEC660A</p>	
<ol style="list-style-type: none"> <li>Turn ignition switch "ON".</li> <li>Check voltage between terminal 1 and ground with CONSULT or tester.</li> </ol>	
 <p style="text-align: right;">SEF728U</p>	
<p style="text-align: center;"><b>Voltage: Approximately 5V</b></p> <p style="text-align: center;"><b>OK or NG</b></p>	
OK	▶ GO TO 2.
NG	▶ Repair open circuit or short to ground or short to power in harness or connectors.

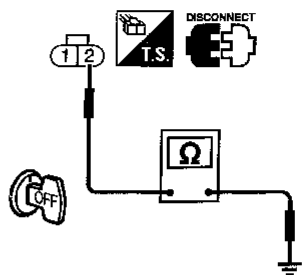
<b>2</b>	<b>CHECK GROUND CIRCUIT</b>
<ol style="list-style-type: none"> <li>Turn ignition switch "OFF".</li> <li>Check harness continuity between terminal 2 and engine ground.</li> </ol>	
 <p style="text-align: right;">SEF729U</p>	
<p style="text-align: center;"><b>Continuity should exist.</b></p> <ol style="list-style-type: none"> <li>Also check harness for short to ground or short to power.</li> </ol> <p style="text-align: center;"><b>OK or NG</b></p>	
OK	▶ GO TO 4.
NG	▶ GO TO 3.

<b>3</b>	<b>DETECT MALFUNCTIONING PART</b>
<p>Check the following.</p> <ul style="list-style-type: none"> <li>Harness connectors F28, M58</li> <li>Joint connector-4</li> <li>Harness for open or short between ECM and EGR temperature sensor</li> <li>Harness for open or short between TCM (Transmission Control Module) and EGR temperature sensor</li> </ul>	
<p style="text-align: right;">▶ Repair open circuit or short to ground or short to power in harness or connector.</p>	

<b>4</b>	<b>CHECK EGR TEMPERATURE SENSOR</b>
<p>Refer to "Component Inspection", EC-388.</p> <p style="text-align: center;"><b>OK or NG</b></p>	
OK	▶ GO TO 5.
NG	▶ Replace EGR temperature sensor.

<b>5</b>	<b>CHECK INTERMITTENT INCIDENT</b>
<p>Refer to "TROUBLE DIAGNOSIS FOR INTERMITTENT INCIDENT", EC-115.</p>	
<p style="text-align: right;">▶ INSPECTION END</p>	

GI  
MA  
EM  
LC  
EC  
FE  
CL  
MT  
AT  
TF  
PD  
FA  
RA  
BR  
ST  
RS  
BT  
HA  
EL  
IDX

# DTC P1401 EGR TEMPERATURE SENSOR

## Component Inspection

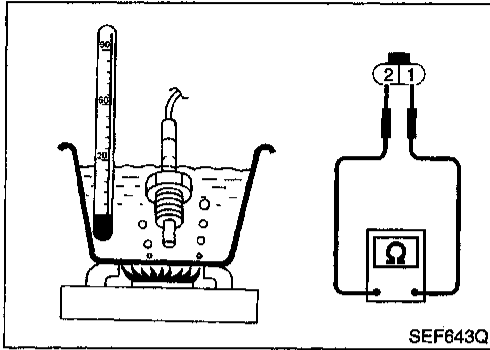

SEF643Q

## Component Inspection EGR TEMPERATURE SENSOR

NEEC0315

NEEC0315S01

Check resistance change and resistance value.

### <Reference data>

EGR temperature °C (°F)	Voltage (V)	Resistance (MΩ)
0 (32)	4.81	7.9 - 9.7
50 (122)	2.82	0.57 - 0.70
100 (212)	0.8	0.08 - 0.10

If NG, replace EGR temperature sensor.

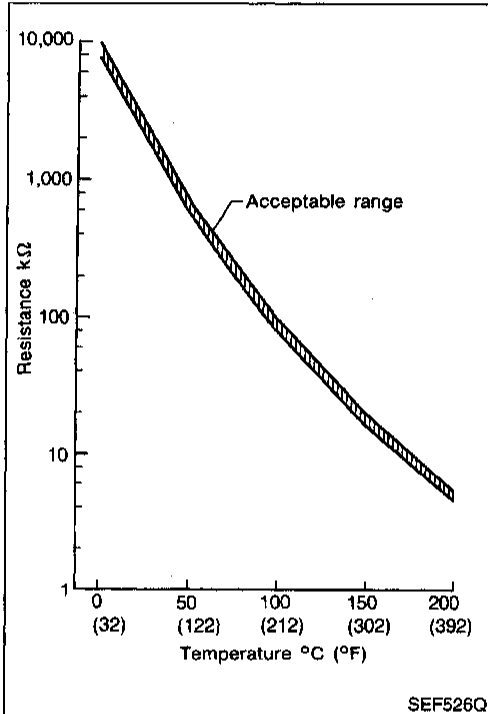

SEF526Q

# DTC P1402 EGR FUNCTION (OPEN)

Description

## Description SYSTEM DESCRIPTION

NEEC0475

NEEC0475S01

Sensor	Input Signal to ECM	ECM function	Actuator
Camshaft position sensor	Engine speed	EGR control	EGRC-solenoid valve
Mass air flow sensor	Amount of intake air		
Engine coolant temperature sensor	Engine coolant temperature		
Ignition switch	Start signal		
Throttle position sensor	Throttle position		

This system cuts and controls vacuum applied to the EGR valve to suit engine operating conditions. This cut-and-control operation is accomplished through the ECM and the EGRC-solenoid valve. When the ECM detects any of the following conditions, current does not flow through the solenoid valve. This causes the intake manifold vacuum to be discharged into the atmosphere. The EGR valve remains closed.

- Low engine coolant temperature
- Engine starting
- High-speed engine operation
- Engine idling
- Excessively high engine coolant temperature
- Mass air flow sensor malfunction

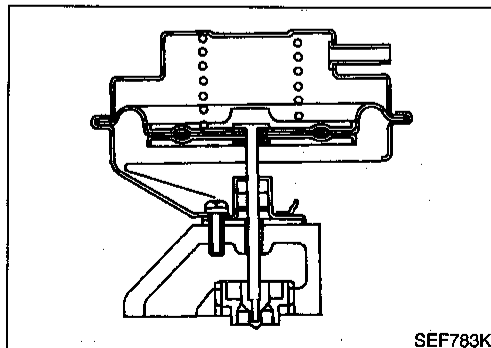
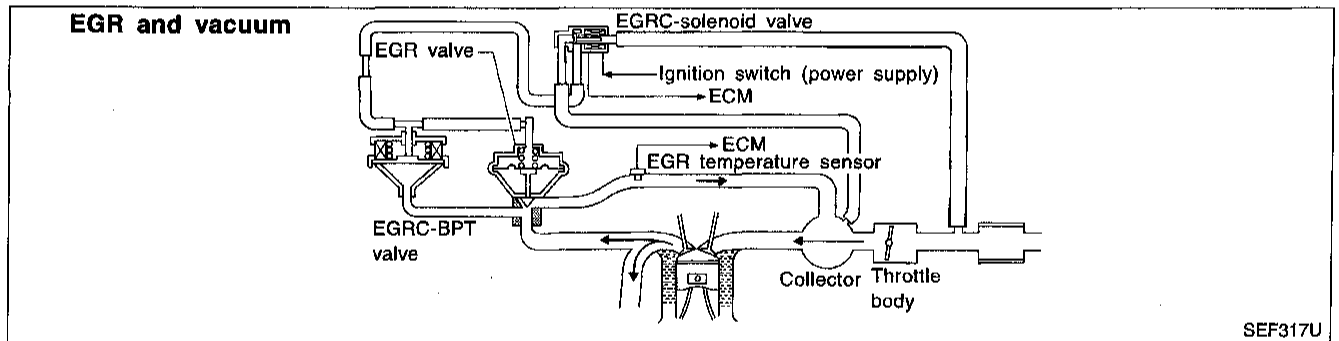

### COMPONENT DESCRIPTION

#### Exhaust Gas Recirculation (EGR) Valve

NEEC0475S02

NEEC0475S0201

The EGR valve controls the amount of exhaust gas routed to the intake manifold. Vacuum is applied to the EGR valve in response to throttle valve opening and EGRC-BPT valve operation. The vacuum controls the movement of a taper valve connected to the vacuum diaphragm in the EGR valve.

## DTC P1402 EGR FUNCTION (OPEN)

Description (Cont'd)

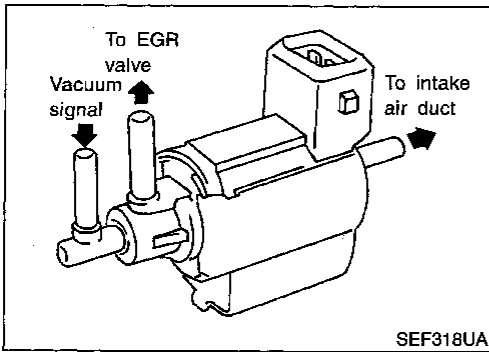

### EGRC-solenoid Valve

NEEC0476S0202

The EGRC-solenoid valve responds to signals from the ECM. When the ECM sends an ON (ground) signal, the coil in the solenoid valve is energized. The vacuum signal (from the intake manifold collector) passes through the solenoid valve. The signal then reaches the EGR valve.

When the ECM sends an OFF signal, a plunger will then move to cut the vacuum signal.

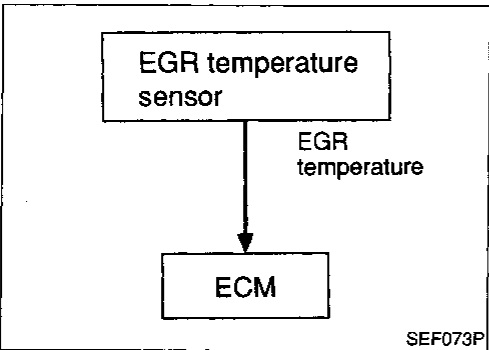

### On Board Diagnosis Logic

NEEC0476

If the EGR temperature sensor detects EGR flow under the condition that does not call for EGR, a high-flow malfunction is diagnosed.

#### NOTE:

Diagnosis for this DTC will end when engine coolant temperature is approx. 50-60°C (122-140°F). Ignition switch must be turned "ON" (engine start) with engine coolant temperature below 40°C (104°F) when starting DTC confirmation procedure.

DTC No.	Malfunction is detected when ...	Check Items (Possible Cause)
P1402 0514	EGR flow is detected under conditions that do not call for EGR.	<ul style="list-style-type: none"> <li>• EGRC-solenoid valve</li> <li>• EGR valve leaking or stuck open</li> <li>• EGR temperature sensor</li> <li>• EGRC-BPT valve</li> </ul>

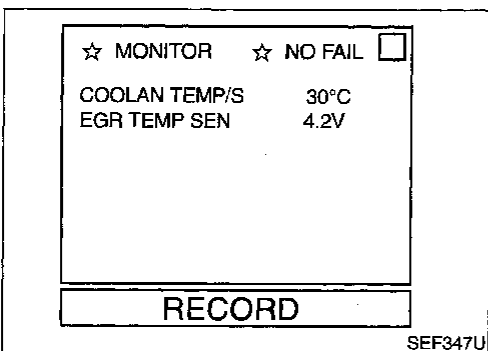

### DTC Confirmation Procedure

NEEC0477

#### NOTE:

If "DTC Confirmation Procedure" has been previously conducted, always turn ignition switch "OFF" and wait at least 5 seconds before conducting the next test.

#### TESTING CONDITION:

- Always perform the test at a temperature of -10°C (14°F) or higher.
- Engine coolant temperature and EGR temperature must be verified in "DATA MONITOR" mode with CONSULT before starting DTC WORK SUPPORT test. If it is out of range below, the test cannot be conducted.

COOLAN TEMP/S: -10 to 30°C (14 to 86°F)\*

EGR TEMP SEN: Less than 4.8V

If the values are out of the ranges indicated above, park the vehicle in a cool place and allow the engine temperature to stabilize. Do not attempt to reduce the engine coolant temperature or EGR temperature with a fan or means other than ambient air. Doing so may produce an inaccurate diagnostic result.

\*: Although CONSULT screen displays "-10 to 40°C (14 to 104°F)" as a range of engine coolant temperature, ignore it.

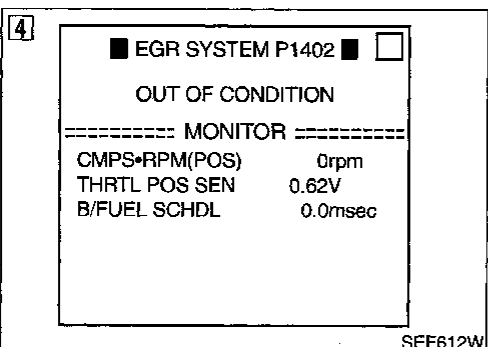

# DTC P1402 EGR FUNCTION (OPEN)

DTC Confirmation Procedure (Cont'd)

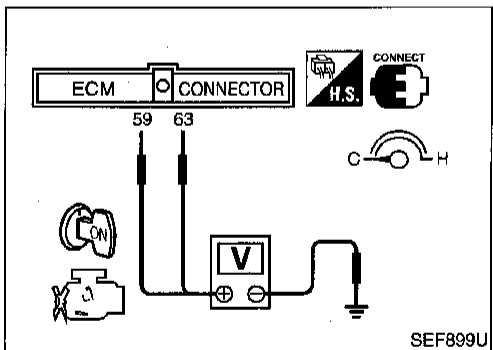
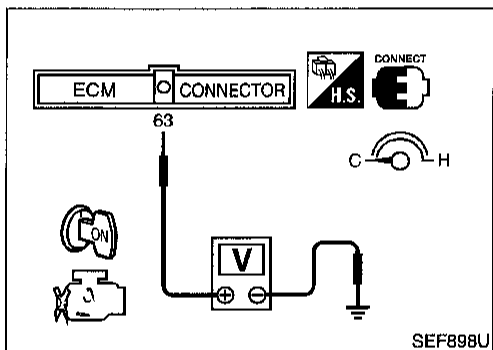
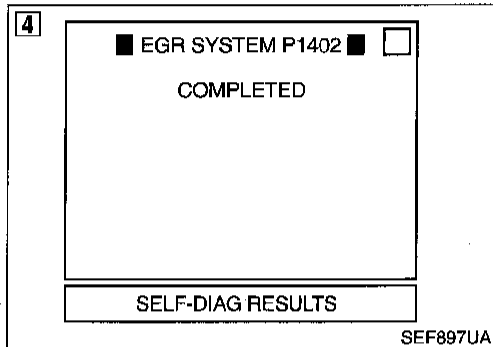
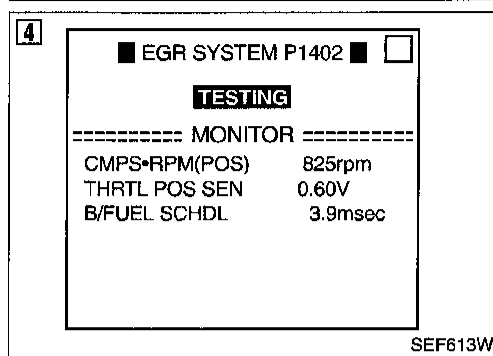

## With CONSULT

- 1) Turn ignition switch "OFF", and wait at least 5 seconds, and then turn "ON".
- 2) Select "EGR SYSTEM P1402" of "EGR SYSTEM" in "DTC WORK SUPPORT" mode with CONSULT.
- 3) Follow the CONSULT instructions.
- 4) Start engine and let it idle until "TESTING" on CONSULT screen is turned to "COMPLETED". (It will take 60 seconds or more.)  
If "TESTING" is not displayed after 5 minutes, turn ignition "OFF" and cool the engine coolant temperature to the range of -10 to 30°C (14 to 86°F). Retry from step 1.
- 5) Make sure that "OK" is displayed after touching "SELF-DIAG RESULTS". If "NG" is displayed, refer to "Diagnostic Procedure", EC-393.

## With GST

- 1) Turn ignition switch "ON" and select "MODE 1" with GST.
- 2) Check that engine coolant temperature is within the range of -10 to 30°C (14 to 86°F).
- 3) Check that voltage between ECM terminal 63 (EGR temperature sensor signal) and ground is less than 4.8V.
- 4) Start engine and let it idle for at least 60 seconds.
- 5) Stop engine.
- 6) Perform from step 1 to 4.
- 7) Select "MODE 3" with GST.
- 8) If DTC is detected, go to "Diagnostic Procedure", EC-393.

## No Tools

- 1) Turn ignition switch "ON".
  - 2) Check the following voltages.
    - ECM terminal 59 (engine coolant temperature sensor signal) and ground:  
3.2 - 4.4V
    - ECM terminal 63 (EGR temperature sensor signal) and ground:  
Less than 4.8V
  - 3) Start engine and let it idle for at least 60 seconds.
  - 4) Turn ignition switch "OFF", wait at least 5 seconds and then turn "ON".
  - 5) Perform "Diagnostic Test Mode II (Self-diagnostic results)" with ECM.
  - 6) If NG, go to "Diagnostic Procedure", EC-393.
- When using GST, "DTC Confirmation Procedure" should be performed twice as much as when using CONSULT or ECM (Diagnostic Test Mode II) because GST cannot display MODE 7 (1st trip DTC) concerning this diagnosis. Therefore, using CONSULT or ECM (Diagnostic Test Mode II) is recommended.

# DTC P1402 EGR FUNCTION (OPEN)

Wiring Diagram

## Wiring Diagram

NEEC0478

EC-EGRC1-01

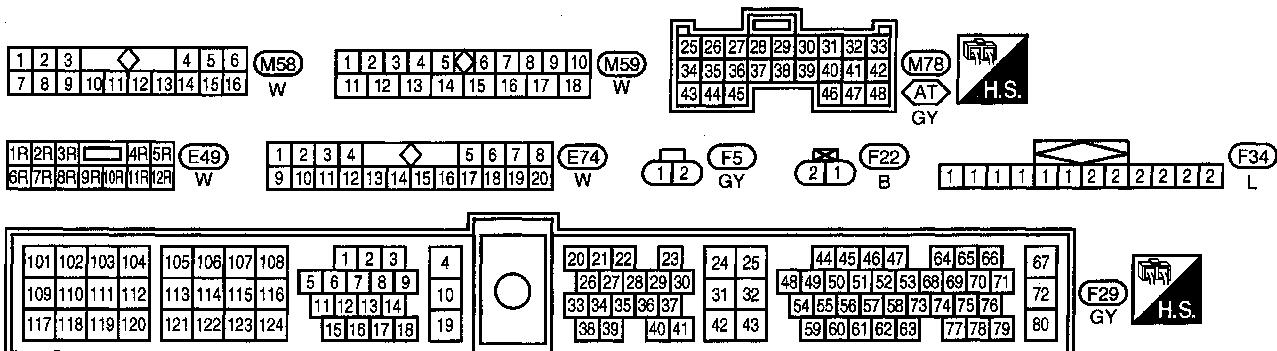
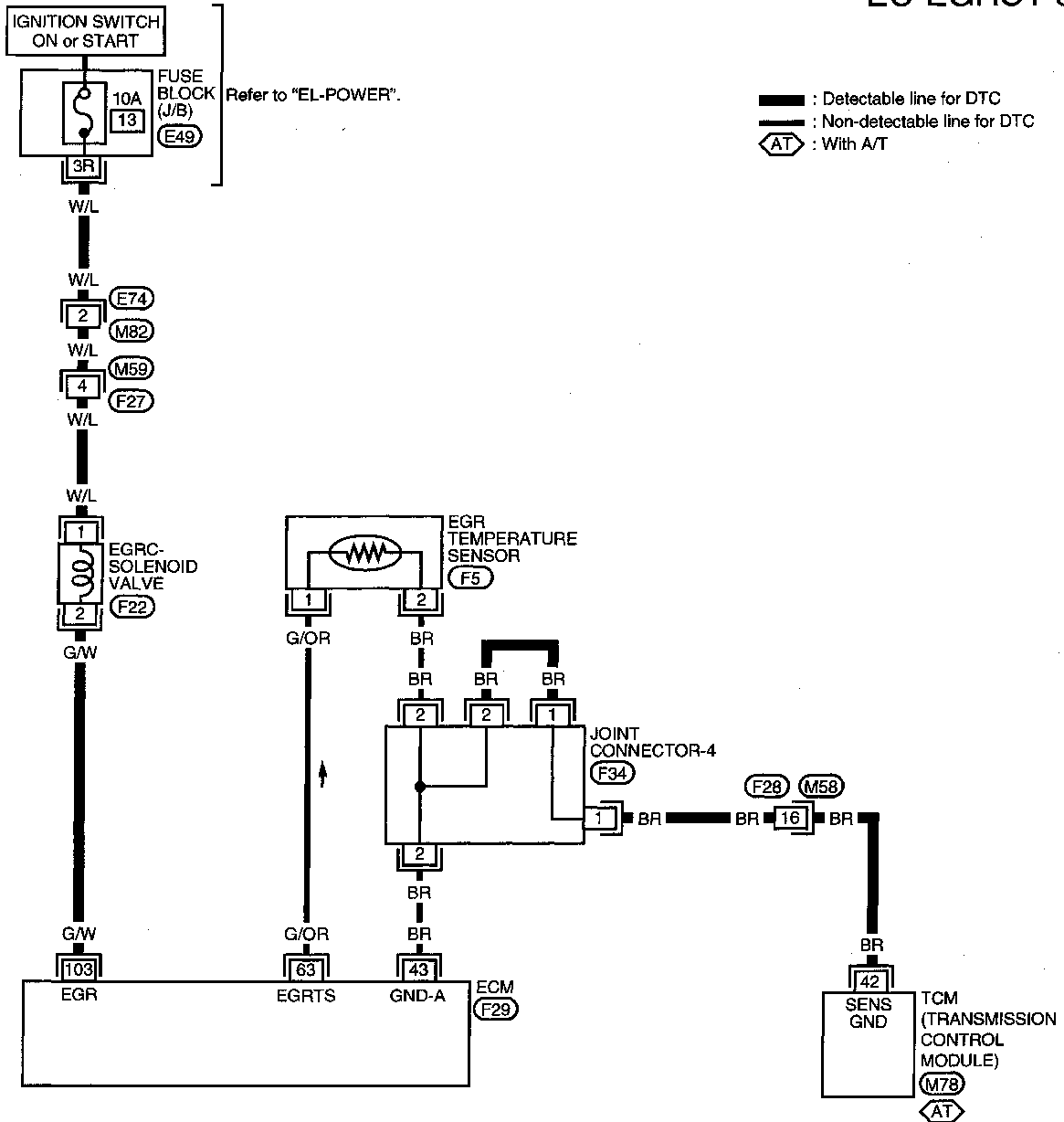

AEC742A

# DTC P1402 EGR FUNCTION (OPEN)

Diagnostic Procedure

## Diagnostic Procedure

NEEC0479

1 CHECK VACUUM HOSE	
1. Turn ignition switch "OFF". 2. Check vacuum hose for clogging, cracks or improper connection. Refer to "Vacuum Hose Drawing", EC-18.	
<p>The diagram illustrates three common vacuum hose problems: a hose with a longitudinal crack labeled 'Split', a hose partially blocked by debris labeled 'Clogging', and a hose that is not fully seated on its fitting labeled 'Improper connection'.</p>	
SEF109L	
<b>OK or NG</b>	
OK (with CONSULT) ▶	GO TO 2.
OK (without CONSULT) ▶	GO TO 3.
NG ▶	Repair or replace vacuum hose.

2 CHECK EGRC-SOLENOID VALVE CIRCUIT																
Ⓜ With CONSULT 1. Turn ignition switch "ON". 2. Perform "EGRC SOL/V CIRCUIT" in "FUNCTION TEST" mode with CONSULT.																
<table border="1"> <tr> <td colspan="2" style="text-align: center;">■ EGRC SOL/V CIRCUIT ■</td> </tr> <tr> <td colspan="2" style="text-align: center;">DOES THE SOLENOID VALVE MAKE AN OPERATING SOUND EVERY 3 SECONDS?</td> </tr> <tr> <td style="text-align: center;">NEXT</td> <td style="text-align: center;">NO YES</td> </tr> </table>		■ EGRC SOL/V CIRCUIT ■		DOES THE SOLENOID VALVE MAKE AN OPERATING SOUND EVERY 3 SECONDS?		NEXT	NO YES									
■ EGRC SOL/V CIRCUIT ■																
DOES THE SOLENOID VALVE MAKE AN OPERATING SOUND EVERY 3 SECONDS?																
NEXT	NO YES															
MEF957D																
Ⓜ With CONSULT 1. Turn ignition switch "ON". 2. Turn EGRC-solenoid valve "ON" and "OFF" in "ACTIVE TEST" mode with CONSULT and check operating sound.																
<table border="1"> <tr> <td colspan="2" style="text-align: center;">■ ACTIVE TEST ■</td> <td style="text-align: center;"><input type="checkbox"/></td> </tr> <tr> <td>EGRC SOL/V (EGR)</td> <td style="text-align: center;">ON FLOW</td> <td></td> </tr> <tr> <td colspan="3" style="text-align: center;">----- MONITOR -----</td> </tr> <tr> <td>CMPS•RPM(REF)</td> <td style="text-align: center;">0rpm</td> <td></td> </tr> <tr> <td style="text-align: center;">ON</td> <td style="text-align: center;">ON/OFF</td> <td style="text-align: center;">OFF</td> </tr> </table>		■ ACTIVE TEST ■		<input type="checkbox"/>	EGRC SOL/V (EGR)	ON FLOW		----- MONITOR -----			CMPS•RPM(REF)	0rpm		ON	ON/OFF	OFF
■ ACTIVE TEST ■		<input type="checkbox"/>														
EGRC SOL/V (EGR)	ON FLOW															
----- MONITOR -----																
CMPS•RPM(REF)	0rpm															
ON	ON/OFF	OFF														
Clicking noise should be heard.																
<b>OK or NG</b>																
OK ▶	GO TO 5.															
NG ▶	GO TO 4.															
SEF789U																

GI  
MA  
EM  
LC  
EC  
FE  
CL  
MT  
AT  
TF  
PD  
FA  
RA  
BR  
ST  
RS  
BT  
HA  
EL  
IDX

## DTC P1402 EGR FUNCTION (OPEN)

Diagnostic Procedure (Cont'd)

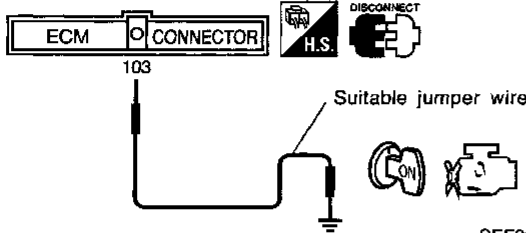
<b>3</b>	<b>CHECK EGRC-SOLENOID VALVE CIRCUIT</b>						
<p><b>⊗ Without CONSULT</b></p> <ol style="list-style-type: none"> <li>1. Disconnect ECM harness connector.</li> <li>2. Turn ignition switch "ON".</li> <li>3. Connect a suitable jumper wire between ECM terminal 103 and engine ground.</li> </ol>							
							
<p>4. Check operating sound of EGRC-solenoid valve when disconnecting and connecting the jumper wire. <b>Clicking noise should be heard.</b></p>							
<p><b>OK or NG</b></p> <table style="width: 100%; border: none;"> <tr> <td style="width: 15%; border: none;">OK</td> <td style="width: 10%; border: none;">▶</td> <td style="border: none;">GO TO 4.</td> </tr> <tr> <td style="border: none;">NG</td> <td style="border: none;">▶</td> <td style="border: none;">Repair or replace EGRC-solenoid valve or repair circuit.</td> </tr> </table>		OK	▶	GO TO 4.	NG	▶	Repair or replace EGRC-solenoid valve or repair circuit.
OK	▶	GO TO 4.					
NG	▶	Repair or replace EGRC-solenoid valve or repair circuit.					

<b>4</b>	<b>CHECK EGRC-SOLENOID VALVE</b>	
Refer to "Component Inspection", EC-380.		
<b>OK or NG</b>		
OK	▶	GO TO 5.
NG	▶	Replace EGRC-solenoid valve.

<b>5</b>	<b>CHECK EGR VALVE</b>	
Refer to "Component Inspection", EC-394.		
<b>OK or NG</b>		
OK	▶	GO TO 6.
NG	▶	Replace EGR valve.

<b>6</b>	<b>CHECK EGRC-BPT VALVE</b>	
Refer to "Component Inspection", EC-394.		
<b>OK or NG</b>		
OK	▶	GO TO 7.
NG	▶	Replace EGRC-BPT valve.

<b>7</b>	<b>CHECK EGR TEMPERATURE SENSOR</b>	
Refer to "Component Inspection", EC-388.		
<b>OK or NG</b>		
OK	▶	GO TO 8.
NG	▶	Replace EGR temperature sensor.

<b>8</b>	<b>CHECK INTERMITTENT INCIDENT</b>
Refer to "TROUBLE DIAGNOSIS FOR INTERMITTENT INCIDENT", EC-115.	
▶ <b>INSPECTION END</b>	

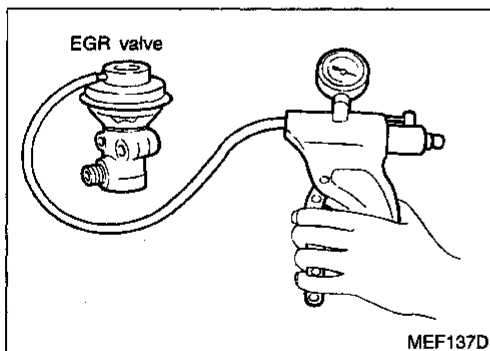

### Component Inspection EGR VALVE

Apply vacuum to EGR vacuum port with a hand vacuum pump. **EGR valve spring should lift.**

- Check for sticking.
- If NG, repair or replace EGR valve.

NEEC0480

NEEC0480S01

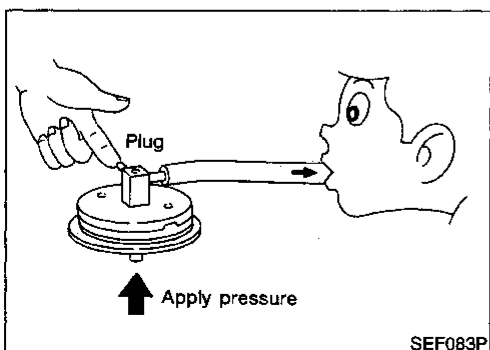

### EGRC-BPT VALVE

1. Plug one of two ports of EGRC-BPT valve.
2. Vacuum from the other port and check for leakage while applying a pressure above 0.981 kPa (100 mmH<sub>2</sub>O, 3.94 inH<sub>2</sub>O) from under EGRC-BPT valve.
3. If a leakage is noted, replace the valve.

NEEC0480S04



# DTC P1440 EVAPORATIVE EMISSION (EVAP) CONTROL SYSTEM (SMALL LEAK) (POSITIVE PRESSURE)

On Board Diagnosis Logic

## On Board Diagnosis Logic

NEEC0481

### NOTE:

If DTC P1440 is displayed with P1448, perform trouble diagnosis for DTC P1448 first. (See EC-420.)

This diagnosis detects leaks in the EVAP purge line using of vapor pressure in the fuel tank.

The EVAP canister vent control valve is closed to shut the EVAP purge line. The vacuum cut valve bypass valve will then be opened to clear the line between the fuel tank and the EVAP canister purge volume control solenoid valve. The EVAP control system pressure sensor can now monitor the pressure inside the fuel tank.

If pressure increases, the ECM will check for leaks in the line between the vacuum cut valve and EVAP canister purge volume control solenoid valve.

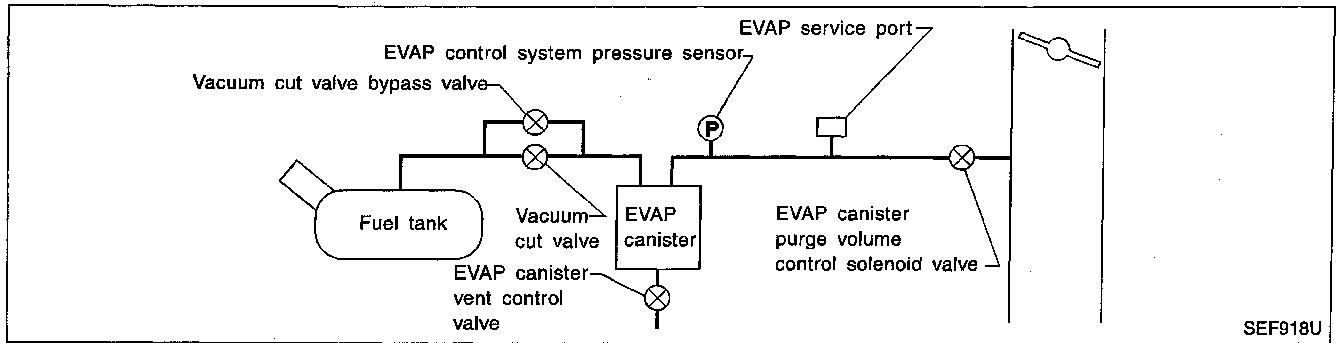

DTC No.	Malfunction is detected when ...	Check Items (Possible Cause)
P1440 0213	<ul style="list-style-type: none"> <li>• EVAP control system has a leak.</li> <li>• EVAP control system does not operate properly.</li> </ul>	<ul style="list-style-type: none"> <li>• Incorrect fuel tank vacuum relief valve</li> <li>• Incorrect fuel filler cap used</li> <li>• Fuel filler cap remains open or fails to close.</li> <li>• Foreign matter caught in fuel filler cap.</li> <li>• Leak is in line between intake manifold and EVAP canister purge volume control solenoid valve.</li> <li>• Foreign matter caught in EVAP canister vent control valve.</li> <li>• EVAP canister or fuel tank leaks</li> <li>• EVAP purge line (pipe and rubber tube) leaks</li> <li>• EVAP purge line rubber tube bent.</li> <li>• Blocked or bent rubber tube to EVAP control system pressure sensor</li> <li>• Loose or disconnected rubber tube</li> <li>• EVAP canister vent control valve and the circuit</li> <li>• EVAP canister purge volume control solenoid valve</li> <li>• Absolute pressure sensor</li> <li>• Tank fuel temperature sensor</li> <li>• MAP/BARO switch solenoid valve</li> <li>• Blocked or bent rubber tube to MAP/BARO switch solenoid valve</li> <li>• O-ring of EVAP canister vent control valve is missing or damaged.</li> <li>• Water separator</li> <li>• EVAP canister is saturated with water.</li> <li>• EVAP control system pressure sensor</li> </ul>

### CAUTION:

- Use only a genuine NISSAN fuel filler cap as a replacement. If an incorrect fuel filler cap is used, the MIL may come on.
- If the fuel filler cap is not tightened properly, the MIL may come on.
- Use only a genuine NISSAN rubber tube as a replacement.

# DTC P1440 EVAPORATIVE EMISSION (EVAP) CONTROL SYSTEM (SMALL LEAK) (POSITIVE PRESSURE)

DTC Confirmation Procedure

## DTC Confirmation Procedure

NEEC0482

### NOTE:

- If DTC P1440 is displayed with P1448, perform trouble diagnosis for DTC P1448 first. (See EC-420.)
- If "DTC Confirmation Procedure" has been previously conducted, always turn ignition switch "OFF" and wait at least 5 seconds before conducting the next test.

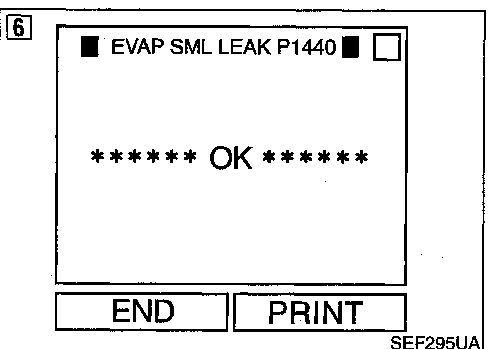
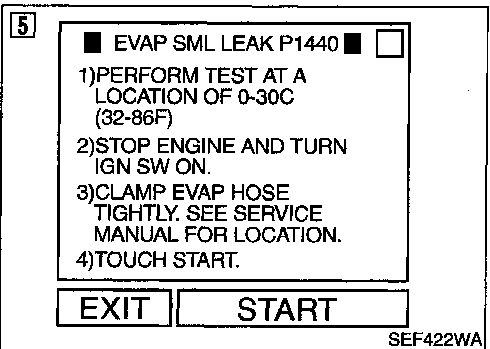
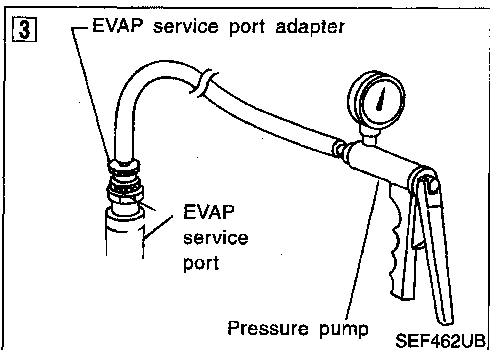
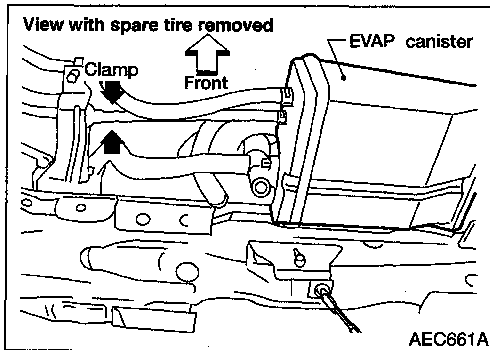

### With CONSULT

#### CAUTION:

- Never use compressed air or high pressure pump. Otherwise, EVAP system may be damaged.
- Do not exceed 4.12 kPa (0.042 kg/cm<sup>2</sup>, 0.6 psi) of pressure in EVAP system.
- Do not start engine.

#### NOTE:

- Always remove EVAP service port adapter from EVAP service port after applying air up to 0.69 to 1.38 kPa (5.14 to 10.34 mmHg, 0.202 to 0.407 inHg).
- During the test, clamp the EVAP hose tightly as shown at left.
  - 1) Turn ignition switch "OFF".
  - 2) Clamp the EVAP hose as shown at left.
  - 3) Install EVAP service port adapter and pressure pump to EVAP service port securely.
  - 4) Turn ignition switch "ON".
  - 5) Select "EVAP SML LEAK P1440" of "EVAPORATIVE SYSTEM" in "DTC WORK SUPPORT" mode with CONSULT. Follow the instruction displayed.
  - 6) Make sure that "OK" is displayed. If "NG" is displayed, refer to "Diagnostic Procedure", EC-397.

### With GST

#### NOTE:

- Be sure to read the explanation of "Driving Pattern" on EC-49 before driving vehicle.
- It is better that fuel level is low.
  - 1) Start engine.
  - 2) Drive vehicle according to "Driving Pattern", EC-49.
  - 3) Stop vehicle.
  - 4) Select "MODE 1" with GST.
    - If SRT of EVAP system is not set yet, go to the following step.
    - If SRT of EVAP system is set, the result will be OK.
  - 5) Turn ignition switch "OFF" and wait at least 5 seconds.
  - 6) Start engine.
    - It is not necessary to cool engine down before driving.
  - 7) Drive vehicle again according to the "Driving Pattern", EC-49.
  - 8) Stop vehicle.
  - 9) Select "MODE 3" with GST.
    - If P0440 is displayed on the screen, go to "Diagnostic Procedure", EC-305.
    - If P1440 is displayed on the screen, go to "Diagnostic Procedure" for "DTC P1440", EC-397.

# DTC P1440 EVAPORATIVE EMISSION (EVAP) CONTROL SYSTEM (SMALL LEAK) (POSITIVE PRESSURE)

DTC Confirmation Procedure (Cont'd)

- If P1447 is displayed on the screen, go to "Diagnostic Procedure" for "DTC P1447", EC-417.
  - If P0440, P1440 and P1447 are not displayed on the screen, go to the following step.
- 10) Select "MODE 1" with GST.
- If SRT of EVAP system is set, the result will be OK.
  - If SRT of EVAP system is not set, go to step 5.

 **No Tools**

**NOTE:**

- Be sure to read the explanation of "Driving Pattern" on EC-49 before driving vehicle.
  - It is better that the fuel level is low.
- 1) Start engine.
  - 2) Drive vehicle according to "Driving Pattern", EC-49.
  - 3) Stop vehicle.
  - 4) Turn ignition switch "OFF" and wait at least 5 seconds.
  - 5) Turn ignition switch "ON" and perform "Diagnostic Test Mode II (Self-diagnostic results)" with ECM.
  - 6) If 1st trip DTC is detected, go to "Diagnostic Procedure", EC-397.

## Diagnostic Procedure

NEEC0463

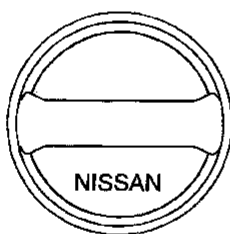
<b>1</b>	<b>CHECK FUEL FILLER CAP DESIGN</b>
1. Turn ignition switch "OFF". 2. Check for genuine NISSAN fuel filler cap design.	
	
SEF915U	
<b>OK or NG</b>	
OK	▶ GO TO 2.
NG	▶ Replace with a genuine NISSAN fuel filler cap.

<b>3</b>	<b>CHECK FUEL FILLER CAP FUNCTION</b>
Check for air releasing sound while opening the fuel filler cap.	
<b>OK or NG</b>	
OK	▶ GO TO 5.
NG	▶ GO TO 4.

<b>4</b>	<b>CHECK FUEL TANK VACUUM RELIEF VALVE</b>
Refer to "Evaporative Emission System", EC-24.	
<b>OK or NG</b>	
OK	▶ GO TO 5.
NG	▶ Replace fuel filler cap with a genuine one.

<b>2</b>	<b>CHECK FUEL FILLER CAP INSTALLATION</b>
Check that the cap is tightened properly by rotating the cap clockwise.	
<b>OK or NG</b>	
OK	▶ GO TO 3.
NG	▶ <ul style="list-style-type: none"> <li>• Open fuel filler cap, then clean cap and fuel filler neck threads using air blower.</li> <li>• Retighten until ratcheting sound is heard.</li> </ul>

GI  
MA  
EM  
LC  
EC  
FE  
CL  
MT  
AT  
TF  
PD  
FA  
RA  
BR  
ST  
RS  
BT  
HA  
EL  
IDX

# DTC P1440 EVAPORATIVE EMISSION (EVAP) CONTROL SYSTEM (SMALL LEAK) (POSITIVE PRESSURE)

Diagnostic Procedure (Cont'd)

## 5 INSTALL THE PRESSURE PUMP

To locate EVAP leak, install EVAP service port adapter and pressure pump to EVAP service port securely.

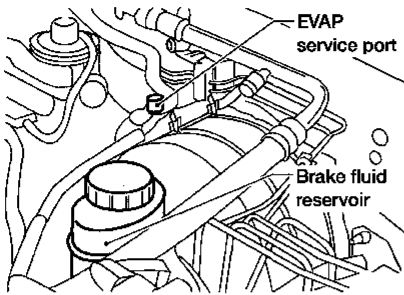

AEC649A

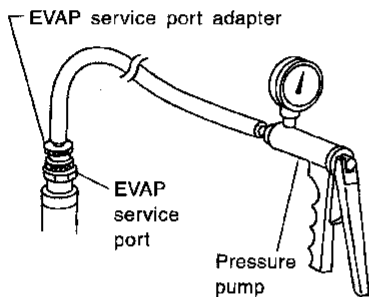

SEF916U

**NOTE:**

Improper installation of EVAP service port adapter to EVAP service port may cause leaking.

Models with CONSULT	▶	GO TO 6.
---------------------	---	----------

Models without CONSULT	▶	GO TO 7.
------------------------	---	----------

## 6 CHECK FOR EVAP LEAK

**With CONSULT**

1. Turn ignition switch "ON".
2. Select "EVAP SYSTEM CLOSE" of "WORK SUPPORT" mode with CONSULT.
3. Touch "START" and apply pressure into the EVAP line until the pressure indicator reaches the middle of the bar graph.

**NOTE:**

- Never use compressed air or a high pressure pump.
- Do not exceed 4.12 kPa (0.042 kg/cm<sup>2</sup>, 0.6 psi) of pressure in the system.

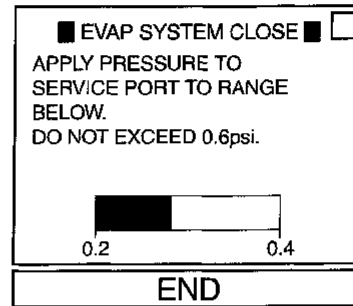

SEF917U

4. Remove EVAP service port adapter and pressure pump.
5. Using EVAP leak detector, locate the EVAP leak. For the leak detector, refer to the instruction manual for more details.

Refer to "Evaporative Emission Line Drawing", EC-28.

Leak detector

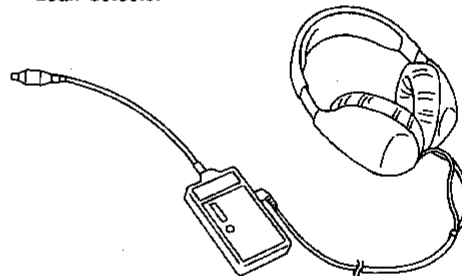

SEF200U

OK or NG

OK	▶	GO TO 8.
----	---	----------

NG	▶	Repair or replace.
----	---	--------------------

# DTC P1440 EVAPORATIVE EMISSION (EVAP) CONTROL SYSTEM (SMALL LEAK) (POSITIVE PRESSURE)

Diagnostic Procedure (Cont'd)

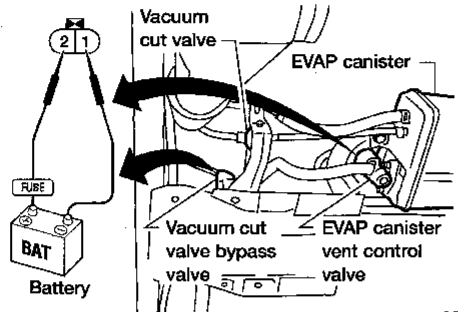
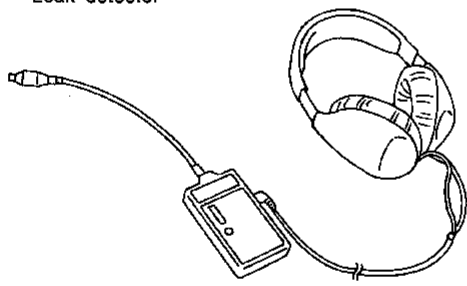
<b>7</b>	<b>CHECK FOR EVAP LEAK</b>
<p><b>⊗ Without CONSULT</b></p> <ol style="list-style-type: none"> <li>Turn ignition switch "OFF".</li> <li>Apply 12 volts DC to EVAP canister vent control valve. The valve will close. (Continue to apply 12 volts until the end of test.)</li> <li>Apply 12 volts DC to vacuum cut valve bypass valve. The valve will open. (Continue to apply 12V until the end of test.)</li> </ol>	
 <p style="text-align: right;">AEC632A</p>	
<ol style="list-style-type: none"> <li>Pressurize the EVAP line using pressure pump with 1.3 to 2.7 kPa (10 to 20 mmHg, 0.39 to 0.79 inHg). <b>NOTE:</b> <ul style="list-style-type: none"> <li>Never use compressed air or a high pressure pump.</li> <li>Do not exceed 4.12 kPa (0.042 kg/cm<sup>2</sup>, 0.6 psi) of pressure in the system.</li> </ul> </li> <li>Remove EVAP service port adapter and pressure pump.</li> <li>Using EVAP leak detector, locate the EVAP leak. For the leak detector, refer to the instruction manual for more details. Refer to "Evaporative Emission Line Drawing", EC-28.</li> </ol>	
 <p style="text-align: right;">SEF200U</p>	
<b>OK or NG</b>	
OK	▶ GO TO 8.
NG	▶ Repair or replace.

<b>8</b>	<b>CHECK WATER SEPARATOR</b>
Refer to "Component Inspection", EC-413.	
<b>OK or NG</b>	
OK	▶ GO TO 9.
NG	▶ Replace water separator.

<b>9</b>	<b>CHECK EVAP CANISTER VENT CONTROL VALVE, O-RING AND CIRCUIT</b>
Refer to "DTC Confirmation Procedure", EC-316.	
<b>OK or NG</b>	
OK	▶ GO TO 10.
NG	▶ Repair or replace EVAP canister vent control valve and O-ring or harness/connector.

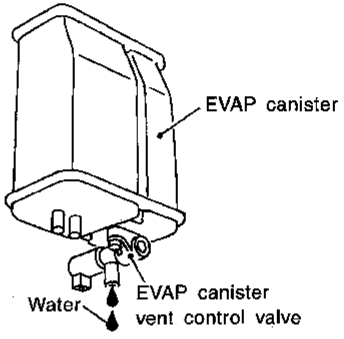
<b>10</b>	<b>CHECK IF EVAP CANISTER SATURATED WITH WATER</b>
<ol style="list-style-type: none"> <li>Remove EVAP canister with EVAP canister vent control valve attached.</li> <li>Check if water will drain from the EVAP canister.</li> </ol>	
 <p style="text-align: right;">SEF596U</p>	
<b>Yes or No</b>	
Yes	▶ GO TO 11.
No (With CONSULT)	▶ GO TO 13.
No (Without CONSULT)	▶ GO TO 14.

<b>11</b>	<b>CHECK EVAP CANISTER</b>
Weigh the EVAP canister with the EVAP canister vent control valve attached. The weight should be less than 1.8 kg (4.0 lb).	
<b>OK or NG</b>	
OK (With CONSULT)	▶ GO TO 13.
OK (Without CONSULT)	▶ GO TO 14.
NG	▶ GO TO 12.

<b>12</b>	<b>DETECT MALFUNCTIONING PART</b>
Check the following. <ul style="list-style-type: none"> <li>EVAP canister for damage</li> <li>EVAP hose between EVAP canister and water separator for clogging or poor connection</li> </ul>	
	▶ Repair hose or replace EVAP canister.

GI  
MA  
EM  
LC  
EC  
FE  
CL  
MT  
AT  
TF  
PD  
FA  
RA  
BR  
ST  
RS  
BT  
HA  
EL  
IDX

# DTC P1440 EVAPORATIVE EMISSION (EVAP) CONTROL SYSTEM (SMALL LEAK) (POSITIVE PRESSURE)

Diagnostic Procedure (Cont'd)

<b>13</b>	<b>CHECK EVAP CANISTER PURGE VOLUME CONTROL SOLENOID VALVE OPERATION</b>																								
<p><b>(B) With CONSULT</b></p> <ol style="list-style-type: none"> <li>1. Disconnect vacuum hose to EVAP canister purge volume control solenoid valve at EVAP service port.</li> <li>2. Start engine.</li> <li>3. Perform "PURG VOL CONT/V" in "ACTIVE TEST" mode.</li> <li>4. Touch "Qu" on CONSULT screen to increase "PURG VOL CONT/V" opening to 100.0%</li> <li>5. Check vacuum hose for vacuum when revving engine up to 2,000 rpm.</li> </ol>																									
<table border="1" style="margin: auto; border-collapse: collapse;"> <tr> <td colspan="2" style="text-align: center;">■ ACTIVE TEST ■</td> </tr> <tr> <td style="padding: 2px;">PURG VOL CONT/V</td> <td style="padding: 2px;">100.0%</td> </tr> <tr> <td colspan="2" style="text-align: center;">===== MONITOR =====</td> </tr> <tr> <td style="padding: 2px;">CMPS•RPM(REF)</td> <td style="padding: 2px;">2187rpm</td> </tr> <tr> <td style="padding: 2px;">FR O2 MNTR-B2</td> <td style="padding: 2px;">RICH</td> </tr> <tr> <td style="padding: 2px;">FR O2 MNTR-B1</td> <td style="padding: 2px;">RICH</td> </tr> <tr> <td style="padding: 2px;">A/F ALPHA-B2</td> <td style="padding: 2px;">100%</td> </tr> <tr> <td style="padding: 2px;">A/F ALPHA-B1</td> <td style="padding: 2px;">100%</td> </tr> <tr> <td style="padding: 2px;">THRTL POS SEN</td> <td style="padding: 2px;">0.64V</td> </tr> <tr> <td colspan="2" style="text-align: center;"> <table style="margin: auto; border: none;"> <tr> <td style="border: 1px solid black; padding: 2px;">Qu</td> <td style="border: 1px solid black; padding: 2px;">UP</td> <td style="border: 1px solid black; padding: 2px;">DWN</td> <td style="border: 1px solid black; padding: 2px;">Qd</td> </tr> </table> </td> </tr> </table>		■ ACTIVE TEST ■		PURG VOL CONT/V	100.0%	===== MONITOR =====		CMPS•RPM(REF)	2187rpm	FR O2 MNTR-B2	RICH	FR O2 MNTR-B1	RICH	A/F ALPHA-B2	100%	A/F ALPHA-B1	100%	THRTL POS SEN	0.64V	<table style="margin: auto; border: none;"> <tr> <td style="border: 1px solid black; padding: 2px;">Qu</td> <td style="border: 1px solid black; padding: 2px;">UP</td> <td style="border: 1px solid black; padding: 2px;">DWN</td> <td style="border: 1px solid black; padding: 2px;">Qd</td> </tr> </table>		Qu	UP	DWN	Qd
■ ACTIVE TEST ■																									
PURG VOL CONT/V	100.0%																								
===== MONITOR =====																									
CMPS•RPM(REF)	2187rpm																								
FR O2 MNTR-B2	RICH																								
FR O2 MNTR-B1	RICH																								
A/F ALPHA-B2	100%																								
A/F ALPHA-B1	100%																								
THRTL POS SEN	0.64V																								
<table style="margin: auto; border: none;"> <tr> <td style="border: 1px solid black; padding: 2px;">Qu</td> <td style="border: 1px solid black; padding: 2px;">UP</td> <td style="border: 1px solid black; padding: 2px;">DWN</td> <td style="border: 1px solid black; padding: 2px;">Qd</td> </tr> </table>		Qu	UP	DWN	Qd																				
Qu	UP	DWN	Qd																						
<p>..... AEC912A</p> <p><b>Vacuum should exist.</b></p>																									
<b>OK or NG</b>																									
OK	▶ GO TO 17.																								
NG	▶ GO TO 15.																								

<b>14</b>	<b>CHECK EVAP CANISTER PURGE VOLUME CONTROL SOLENOID VALVE OPERATION</b>
<p><b>(X) Without CONSULT</b></p> <ol style="list-style-type: none"> <li>1. Start engine and warm it up to normal operating temperature.</li> <li>2. Stop engine.</li> <li>3. Disconnect vacuum hose to EVAP canister purge volume control solenoid valve at EVAP service port.</li> <li>4. Start engine and let it idle for at least 80 seconds.</li> <li>5. Check vacuum hose for vacuum when revving engine up to 2,000 rpm.</li> </ol> <p><b>Vacuum should exist.</b></p>	
<b>OK or NG</b>	
OK	▶ GO TO 17.
NG	▶ GO TO 15.

<b>15</b>	<b>CHECK VACUUM HOSE</b>
<p>Check vacuum hoses for clogging or disconnection. Refer to "Vacuum Hose Drawing", EC-18.</p>	
<b>OK or NG</b>	
OK	▶ GO TO 16.
NG	▶ Repair or reconnect the hose.

<b>16</b>	<b>CHECK EVAP CANISTER PURGE VOLUME CONTROL SOLENOID VALVE</b>
<p>Refer to "Component Inspection", EC-408.</p>	
<b>OK or NG</b>	
OK	▶ GO TO 17.
NG	▶ Replace EVAP canister purge volume control solenoid valve.

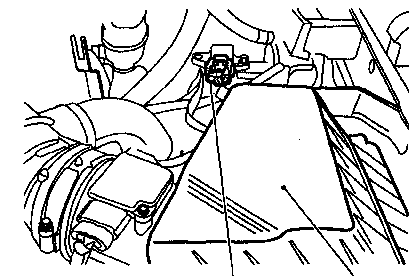
<b>17</b>	<b>CHECK ABSOLUTE PRESSURE SENSOR</b>
<p>Refer to "Component Inspection", EC-138.</p>	
	
<p>Absolute pressure sensor      Air cleaner</p> <p style="text-align: right;">..... AEC642A</p>	
<b>OK or NG</b>	
OK	▶ GO TO 18.
NG	▶ Replace absolute pressure sensor.

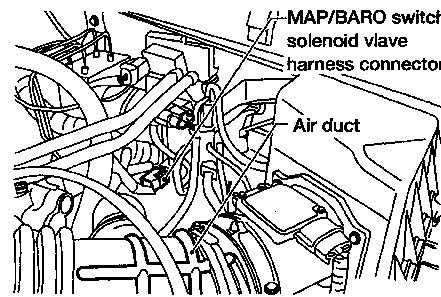
<b>18</b>	<b>CHECK MAP/BARO SWITCH SOLENOID VALVE AND CIRCUIT</b>
<p>Refer to "Component Inspection", EC-363.</p>	
	
<p>MAP/BARO switch solenoid valve harness connector</p> <p style="text-align: right;">Air duct</p> <p style="text-align: right;">..... AEC650A</p>	
<b>OK or NG</b>	
OK	▶ GO TO 19.
NG	▶ Replace MAP/BARO switch solenoid valve.

# DTC P1440 EVAPORATIVE EMISSION (EVAP) CONTROL SYSTEM (SMALL LEAK) (POSITIVE PRESSURE)

Diagnostic Procedure (Cont'd)

<b>19</b>	<b>CHECK TANK FUEL TEMPERATURE SENSOR</b>
Refer to "Component Inspection", EC-265.	
<p style="text-align: right;">AEC933A</p>	
<b>OK or NG</b>	
OK	▶ GO TO 20.
NG	▶ Replace tank fuel temperature sensor.

<b>23</b>	<b>CHECK INTERMITTENT INCIDENT</b>
Refer to "TROUBLE DIAGNOSIS FOR INTERMITTENT INCIDENT", EC-115.	
▶ <b>INSPECTION END</b>	

<b>20</b>	<b>CHECK EVAP CONTROL SYSTEM PRESSURE SENSOR</b>
Refer to "Component Inspection", EC-328.	
<p style="text-align: right;">AEC651A</p>	
<b>OK or NG</b>	
OK	▶ GO TO 21.
NG	▶ Replace EVAP control system pressure sensor.

<b>21</b>	<b>CHECK EVAP PURGE LINE</b>
Check EVAP purge line (pipe, rubber tube, fuel tank and EVAP canister) for cracks or improper connection. Refer to "Evaporative Emission System", EC-24.	
<b>OK or NG</b>	
OK	▶ GO TO 22.
NG	▶ Repair or reconnect the hose.

<b>22</b>	<b>CLEAN EVAP PURGE LINE</b>
Clean EVAP purge line (pipe and rubber tube) using air blower.	
▶ GO TO 23.	

GI  
MA  
EM  
LC  
**EC**  
FE  
CL  
MT  
AT  
TF  
PD  
FA  
RA  
BR  
ST  
RS  
BT  
HA  
EL  
IDX

# DTC P1444 EVAPORATIVE EMISSION (EVAP) CANISTER PURGE VOLUME CONTROL SOLENOID VALVE

Description

## Description SYSTEM DESCRIPTION

NEEC0325

NEEC0325S01

Sensor	Input Signal to ECM	ECM function	Actuator
Camshaft position sensor	Engine speed	EVAP canister purge flow control	EVAP canister purge volume control solenoid valve
Mass air flow sensor	Amount of intake air		
Engine coolant temperature sensor	Engine coolant temperature		
Ignition switch	Start signal		
Throttle position sensor	Throttle position		
Throttle position switch	Closed throttle position		
Front heated oxygen sensors	Density of oxygen in exhaust gas (Mixture ratio feedback signal)		
Tank fuel temperature sensor	Fuel temperature in fuel tank		
Vehicle speed sensor	Vehicle speed		

This system controls flow rate of fuel vapor from the EVAP canister. The opening of the vapor by-pass passage in the EVAP canister purge volume control solenoid valve changes to control the flow rate. The EVAP canister purge volume control solenoid valve repeats ON/OFF operation according to the signal sent from the ECM. The opening of the valve varies for optimum engine control. The optimum value stored in the ECM is determined by considering various engine conditions. When the engine is operating, the flow rate of fuel vapor from the EVAP canister is regulated as the air flow changes.

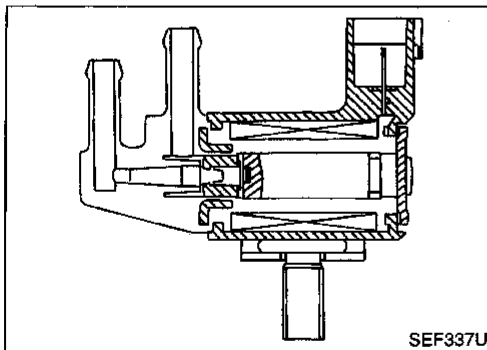

### COMPONENT DESCRIPTION

NEEC0325S02

The EVAP canister purge volume control solenoid valve uses a ON/OFF duty to control the flow rate of fuel vapor from the EVAP canister. The EVAP canister purge volume control solenoid valve is moved by ON/OFF pulses from the ECM. The longer the ON pulse, the greater the amount of fuel vapor that will flow through the valve.

### CONSULT Reference Value in Data Monitor Mode

NEEC0326

Specification data are reference values.

MONITOR ITEM	CONDITION	SPECIFICATION
PURG VOL C/V	<ul style="list-style-type: none"> <li>• Engine: After warming up</li> <li>• Air conditioner switch "OFF"</li> <li>• Shift lever: "N"</li> <li>• No-load</li> </ul>	Idle (Vehicle stopped)
		2,000 rpm
		0%
		—



# DTC P1444 EVAPORATIVE EMISSION (EVAP) CANISTER PURGE VOLUME CONTROL SOLENOID VALVE

ECM Terminals and Reference Value

## ECM Terminals and Reference Value

NEEC0327

Specification data are reference values and are measured between each terminal and 32 (ECM ground).

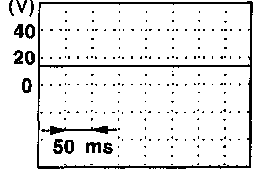
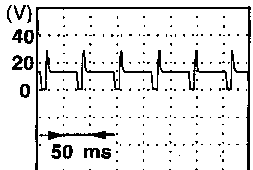
TERMINAL NO.	WIRE COLOR	ITEM	CONDITION	DATA (DC Voltage)
4	OR/B	ECM relay (Self shut-off)	<b>[Engine is running]</b> <b>[Ignition switch "OFF"]</b> <ul style="list-style-type: none"> <li>• For a few seconds after turning ignition switch "OFF"</li> </ul>	0 - 1.5V
			<b>[Ignition switch "OFF"]</b> <ul style="list-style-type: none"> <li>• A few seconds passed after turning ignition switch "OFF"</li> </ul>	BATTERY VOLTAGE (11 - 14V)
5	R/Y	EVAP canister purge volume control solenoid valve	<b>[Engine is running]</b> <ul style="list-style-type: none"> <li>• Idle speed</li> </ul>	BATTERY VOLTAGE (11 - 14V)   SEF994U
			<b>[Engine is running]</b> <ul style="list-style-type: none"> <li>• Engine speed is 2,000 rpm</li> </ul>	BATTERY VOLTAGE (11 - 14V)   SEF995U
67	B/P	Power supply for ECM	<b>[Ignition switch "ON"]</b>	BATTERY VOLTAGE (11 - 14V)
72	B/P			
117	B/P	Current return	<b>[Engine is running]</b> <ul style="list-style-type: none"> <li>• Idle speed</li> </ul>	BATTERY VOLTAGE (11 - 14V)

## On Board Diagnosis Logic

NEEC0328

DTC No.	Malfunction is detected when ...	Check Items (Possible Cause)
P1444 0214	The canister purge flow is detected during the specified driving conditions, even when EVAP canister purge volume control solenoid valve is completely closed.	<ul style="list-style-type: none"> <li>• EVAP control system pressure sensor</li> <li>• EVAP canister purge volume control solenoid valve (The valve is stuck open.)</li> <li>• EVAP canister vent control valve</li> <li>• EVAP canister</li> <li>• Hoses (Hoses are connected incorrectly or clogged.)</li> </ul>

# DTC P1444 EVAPORATIVE EMISSION (EVAP) CANISTER PURGE VOLUME CONTROL SOLENOID VALVE

DTC Confirmation Procedure

## DTC Confirmation Procedure

NEEC0329

### NOTE:

If "DTC Confirmation Procedure" has been previously conducted, always turn ignition switch "OFF" and wait at least 5 seconds before conducting the next test.

### TESTING CONDITION:

Always perform test at a temperature of 5°C (41°F) or more.

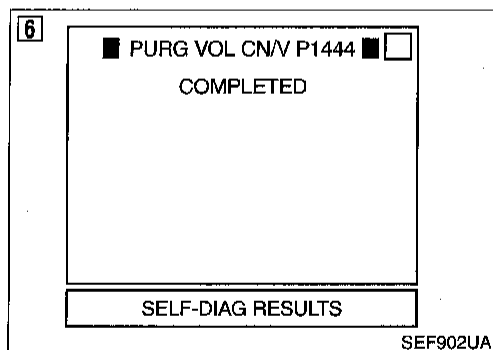
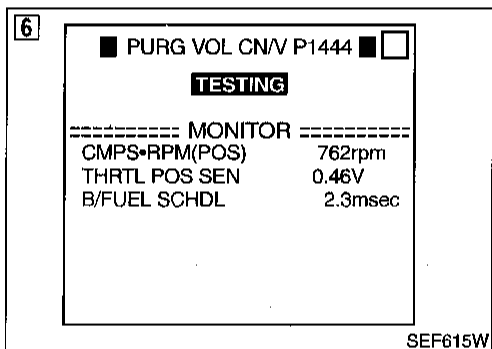
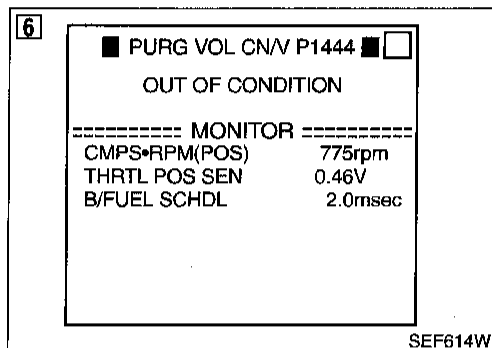

### With CONSULT

- 1) Start engine and warm it up to normal operating temperature.
- 2) Turn ignition switch "OFF" and wait at least 5 seconds.
- 3) Turn ignition switch "ON".
- 4) Select "PURG VOL CN/V P1444" of "EVAPORATIVE SYSTEM" in "DTC WORK SUPPORT" mode with CONSULT.
- 5) Touch "START".
- 6) Start engine and let it idle until "TESTING" on CONSULT changes to "COMPLETED". (It will take for approximately 10 seconds.)  
If "TESTING" is not displayed after 5 minutes, retry from step 2.
- 7) Make sure that "OK" is displayed after touching "SELF-DIAG RESULTS". If "NG" is displayed, refer to "Diagnostic Procedure", EC-406.

### With GST

- 1) Start engine and warm it up to normal operating temperature.
- 2) Turn ignition switch "OFF" and wait at least 5 seconds.
- 3) Start engine and let it idle for at least 20 seconds.
- 4) Select "MODE 7" with GST.
- 5) If 1st trip DTC is detected, go to "Diagnostic Procedure", EC-406.

### No Tools

- 1) Start engine and warm it up to normal operating temperature.
- 2) Turn ignition switch "OFF" and wait at least 5 seconds.
- 3) Start engine and let it idle for at least 20 seconds.
- 4) Turn ignition switch "OFF" and wait at least 5 seconds.
- 5) Turn ignition switch "ON" and perform "Diagnostic Test Mode II (Self-diagnostic results)" with ECM.
- 6) If 1st trip DTC is detected, go to "Diagnostic Procedure", EC-406.

# DTC P1444 EVAPORATIVE EMISSION (EVAP) CANISTER PURGE VOLUME CONTROL SOLENOID VALVE

Wiring Diagram

## Wiring Diagram

NEEC0330

EC-PGC/V-01

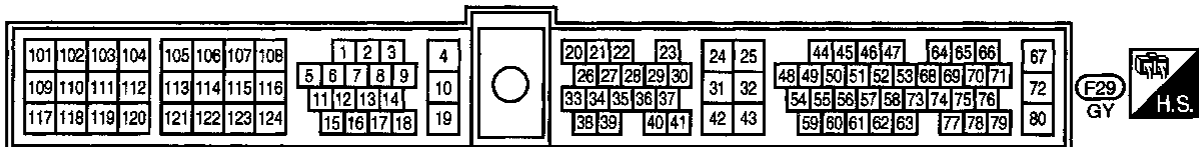
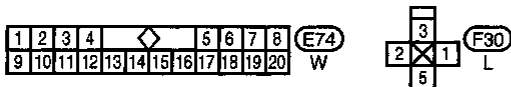
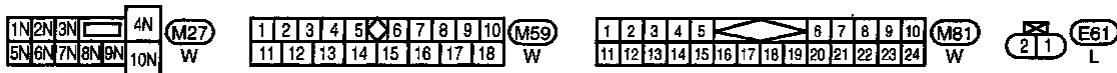
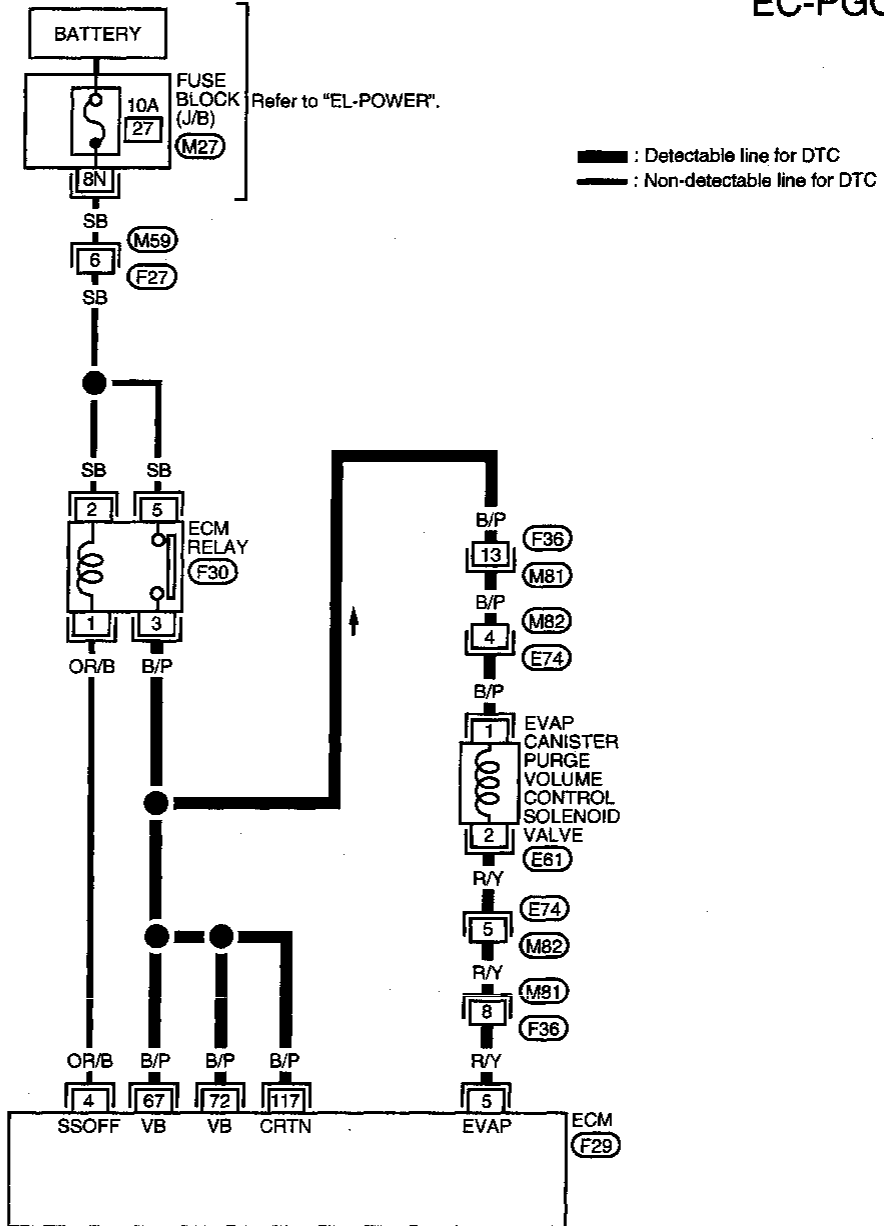

AEC743A

# DTC P1444 EVAPORATIVE EMISSION (EVAP) CANISTER PURGE VOLUME CONTROL SOLENOID VALVE

Diagnostic Procedure

## Diagnostic Procedure

NEEC0331

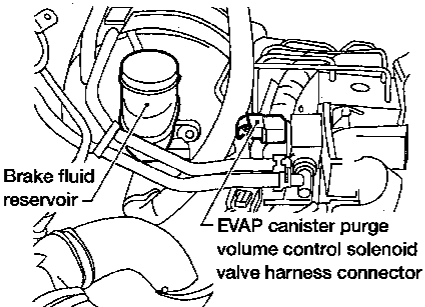
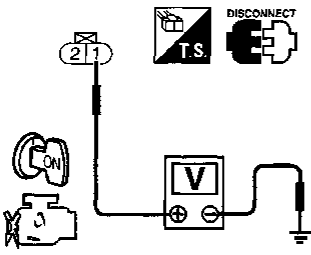
<b>1</b>	<b>CHECK POWER SUPPLY</b>
<p>1. Turn ignition switch "OFF".                  2. Disconnect EVAP canister purge volume control solenoid valve harness connector.</p>	
 <p style="text-align: right;">AEC652A</p>	
<p>3. Turn ignition switch "ON".                  4. Check voltage between terminal 1 and engine ground with CONSULT or tester.</p>	
 <p style="text-align: right;">SEF646W</p>	
Voltage: Battery voltage	
OK or NG	
OK	▶ GO TO 3.
NG	▶ GO TO 2.

<b>2</b>	<b>DETECT MALFUNCTIONING PART</b>
<p>Check the following.</p> <ul style="list-style-type: none"> <li>• Harness connectors F36, M81</li> <li>• Harness connectors M82, E74</li> <li>• Harness for open or short between EVAP canister purge volume control solenoid valve and ECM relay</li> <li>• Harness for open or short between EVAP canister purge volume control solenoid valve and ECM</li> </ul>	
▶ Repair harness or connectors.	

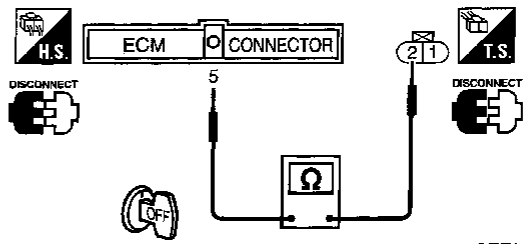
<b>3</b>	<b>CHECK OUTPUT SIGNAL CIRCUIT</b>
<p>1. Turn ignition switch "OFF".                  2. Disconnect ECM harness connector.                  3. Check harness continuity between ECM terminal 5 and terminal 2.</p>	
 <p style="text-align: right;">SEF647W</p>	
Continuity should exist.	
<p>4. Also check harness for short to ground and short to power.</p>	
OK or NG	
OK	▶ GO TO 5.
NG	▶ GO TO 4.

<b>4</b>	<b>DETECT MALFUNCTIONING PART</b>
<p>Check the following.</p> <ul style="list-style-type: none"> <li>• Harness connectors E74, M82</li> <li>• Harness connectors M81, F36</li> <li>• Harness for open or short between EVAP canister purge volume control solenoid valve and ECM</li> </ul>	
▶ Repair open circuit or short to ground or short to power in harness or connectors.	

<b>5</b>	<b>CHECK EVAP CONTROL SYSTEM PRESSURE SENSOR HOSE</b>
<p>Check disconnection or improper connection of hose connected to EVAP control system pressure sensor.</p>	
OK or NG	
OK	▶ GO TO 6.
NG	▶ Repair it.

# DTC P1444 EVAPORATIVE EMISSION (EVAP) CANISTER PURGE VOLUME CONTROL SOLENOID VALVE

Diagnostic Procedure (Cont'd)

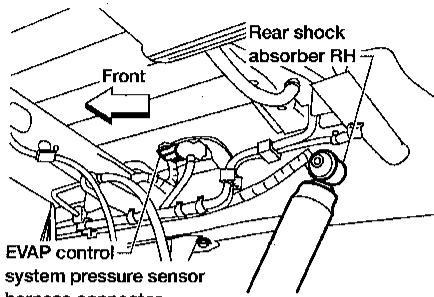
<b>6</b>	<b>CHECK CONNECTOR</b>
1. Disconnect EVAP control system pressure sensor harness connector.	
	
2. Check connectors for water. <b>Water should not exist.</b>	
<b>OK or NG</b>	
OK	▶ GO TO 7.
NG	▶ Replace EVAP control system pressure sensor.

<b>7</b>	<b>CHECK EVAP CONTROL SYSTEM PRESSURE SENSOR</b>
Refer to "Component Inspection", EC-328.	
<b>OK or NG</b>	
OK	▶ GO TO 8.
NG	▶ Replace EVAP control system pressure sensor.

<b>8</b>	<b>CHECK EVAP CANISTER PURGE VOLUME CONTROL SOLENOID VALVE</b>
Refer to "Component Inspection", EC-408.	
<b>OK or NG</b>	
OK	▶ GO TO 9.
NG	▶ Replace EVAP canister purge volume control solenoid valve.

<b>9</b>	<b>CHECK EVAP CANISTER VENT CONTROL VALVE</b>
Refer to "Component Inspection", EC-413.	
<b>OK or NG</b>	
OK	▶ GO TO 10.
NG	▶ Replace EVAP canister vent control valve.

<b>10</b>	<b>CHECK RUBBER TUBE</b>
Check for obstructed water separator and rubber tube connected to EVAP canister vent control valve and clean the rubber tube using air blower. For water separator, refer to EC-413.	
<b>OK or NG</b>	
OK	▶ GO TO 11.
NG	▶ Clean, repair or replace rubber tube and/or water separator.

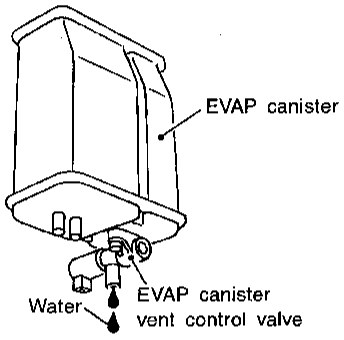
<b>11</b>	<b>CHECK IF EVAP CANISTER SATURATED WITH WATER</b>
1. Remove EVAP canister with EVAP canister vent control valve attached.	
2. Check if water will drain from the EVAP canister.	
	
<b>Yes or No</b>	
Yes	▶ GO TO 12.
No	▶ GO TO 14.

<b>12</b>	<b>CHECK EVAP CANISTER</b>
Weigh the EVAP canister with the EVAP canister vent control valve attached. <b>The weight should be less than 1.8 kg (4.0 lb).</b>	
<b>OK or NG</b>	
OK	▶ GO TO 14.
NG	▶ GO TO 13.

<b>13</b>	<b>DETECT MALFUNCTIONING PART</b>
Check the following.	
<ul style="list-style-type: none"> <li>• EVAP canister for damage</li> <li>• EVAP hose between EVAP canister and water separator for clogging or poor connection</li> </ul>	
▶ Repair hose or replace EVAP canister.	

<b>14</b>	<b>CHECK INTERMITTENT INCIDENT</b>
Refer to "TROUBLE DIAGNOSIS FOR INTERMITTENT INCIDENT", EC-115.	
▶ INSPECTION END	

GI  
MA  
EM  
LC  
EC  
FE  
CL  
MT  
AT  
TF  
PD  
FA  
RA  
BR  
ST  
RS  
BT  
HA  
EL  
IDX

# DTC P1444 EVAPORATIVE EMISSION (EVAP) CANISTER PURGE VOLUME CONTROL SOLENOID VALVE

## Component Inspection

ACTIVE TEST

PURG VOL CONT/V 0.0%

===== MONITOR =====

CMPS•RPM(REF)	787rpm
FR O2 MNTR-B2	RICH
FR O2 MNTR-B1	RICH
A/F ALPHA-B2	100%
A/F ALPHA-B1	100%
THRTL POS SEN	0.44V

Qu
UP
DWN
Qd

SEF892U

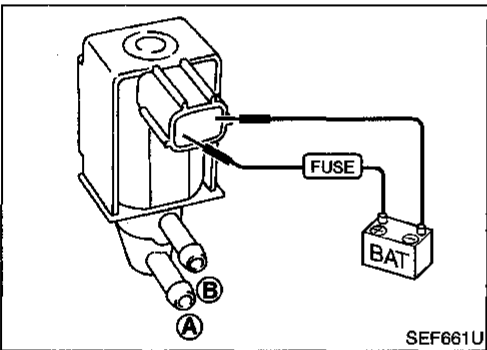
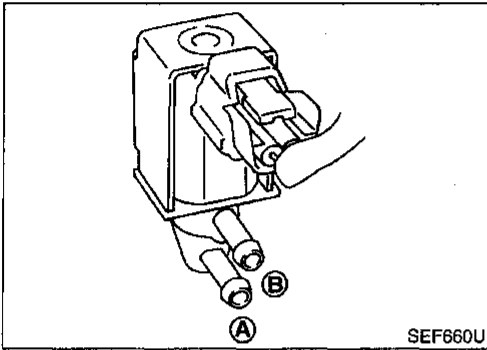

## Component Inspection

### EVAP CANISTER PURGE VOLUME CONTROL SOLENOID VALVE

NEEC0332

NEEC0332S01

#### Ⓐ With CONSULT

1. Start engine.
2. Perform "PURG VOL CONT/V" in "ACTIVE TEST" mode with CONSULT. Check that engine speed varies according to the valve opening.  
If OK, inspection end. If NG, go to following step.
3. Check air passage continuity.

Condition PURG VOL CONT/V value	Air passage continuity between A and B
100.0%	Yes
0.0%	No

If NG, replace the EVAP canister purge volume control solenoid valve.

#### ⓧ Without CONSULT

Check air passage continuity.

Condition	Air passage continuity between A and B
12V direct current supply between terminals	Yes
No supply	No

If NG or operation takes more than 1 second, replace solenoid valve.

# DTC P1446 EVAPORATIVE EMISSION (EVAP) CANISTER VENT CONTROL VALVE (CLOSE)

Component Description

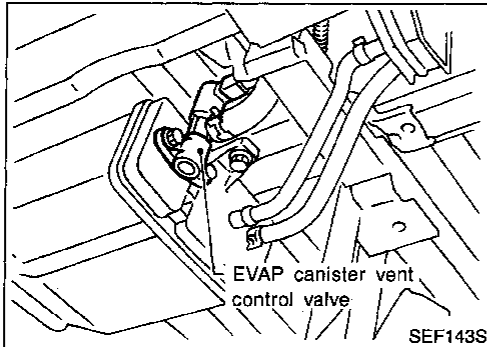
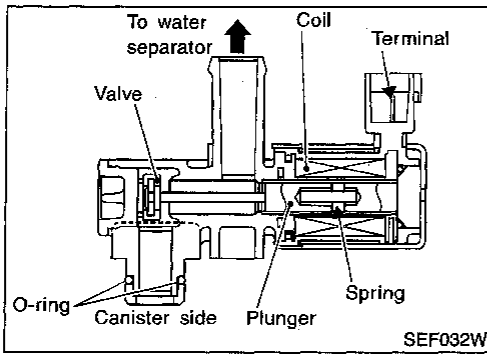

## Component Description

The EVAP canister vent control valve is located on the EVAP canister and is used to seal the canister vent.

This solenoid valve responds to signals from the ECM. When the ECM sends an ON signal, the coil in the solenoid valve is energized. A plunger will then move to seal the canister vent. The ability to seal the vent is necessary for the on board diagnosis of other evaporative emission control system components.

This solenoid valve is used only for diagnosis, and usually remains opened.

When the vent is closed, under normal purge conditions, the evaporative emission control system is depressurized and allows "EVAP Control System (Small Leak)" diagnosis.

## CONSULT Reference Value in Data Monitor Mode

Specification data are reference values.

MONITOR ITEM	CONDITION	SPECIFICATION
VENT CONT/V	• Ignition switch: ON	OFF

## ECM Terminals and Reference Value

Specification data are reference values and are measured between each terminal and 32 (ECM ground).

TERMI-NAL NO.	WIRE COLOR	ITEM	CONDITION	DATA (DC Voltage)
108	R/G	EVAP canister vent control valve	[Ignition switch "ON"]	BATTERY VOLTAGE (11 - 14V)

## On Board Diagnosis Logic

DTC No.	Malfunction is detected when ...	Check Items (Possible Cause)
P1446 0215	• EVAP canister vent control valve remains closed under specified driving conditions.	<ul style="list-style-type: none"> <li>• EVAP canister vent control valve</li> <li>• EVAP control system pressure sensor and the circuit</li> <li>• Blocked rubber tube to EVAP canister vent control valve</li> <li>• Water separator</li> <li>• EVAP canister is saturated with water.</li> </ul>

# DTC P1446 EVAPORATIVE EMISSION (EVAP) CANISTER VENT CONTROL VALVE (CLOSE)

## DTC Confirmation Procedure

4	☆ MONITOR ☆ NO FAIL <input type="checkbox"/>
CMPS•RPM(REF)	1800rpm
COOLAN TEMP/S	20°C
VHCL SPEED SE	80km/h
THRTL POS SEN	0.88V
B/FUEL SCHDL	2.4msec

SEF403VA

## DTC Confirmation Procedure

NEE00488

### CAUTION:

Always drive vehicle at a safe speed.

### NOTE:

If "DTC Confirmation Procedure" has been previously conducted, always turn ignition switch "OFF" and wait at least 5 seconds before conducting the next test.

#### Ⓜ With CONSULT

- 1) Turn ignition switch "ON".
- 2) Select "DATA MONITOR" mode with CONSULT.
- 3) Start engine.
- 4) Drive vehicle at a speed of approximately 80 km/h (50 MPH) for a maximum of 15 minutes.

### NOTE:

If a malfunction exists, NG result may be displayed quicker.

- 5) If 1st trip DTC is detected, go to "Diagnostic Procedure", EC-412.

#### Ⓜ With GST

- 1) Start engine.
- 2) Drive vehicle at a speed of approximately 80 km/h (50 MPH) for 15 minutes.
- 3) Select "MODE 7" with GST.
- 4) If 1st trip DTC is detected, go to "Diagnostic Procedure", EC-412.

#### Ⓜ No Tools

- 1) Start engine.
- 2) Drive vehicle at a speed of approximately 80 km/h (50 MPH) for 15 minutes.
- 3) Turn ignition switch "OFF" and wait at least 5 seconds.
- 4) Turn ignition switch "ON" and perform "Diagnostic Test Mode II (Self-diagnostic results)" with ECM.
- 5) If 1st trip DTC is detected, go to "Diagnostic Procedure", EC-412.



# DTC P1446 EVAPORATIVE EMISSION (EVAP) CANISTER VENT CONTROL VALVE (CLOSE)

Wiring Diagram

## Wiring Diagram

NEEC0489

### EC-VENT/V-01

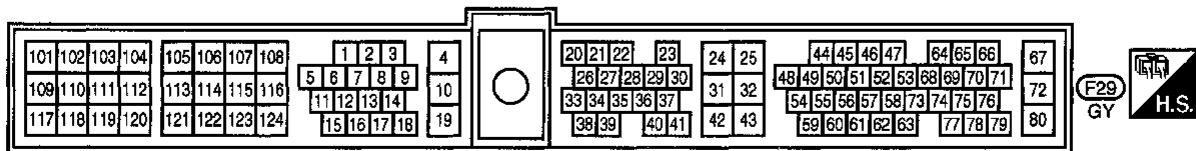
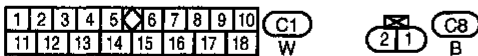
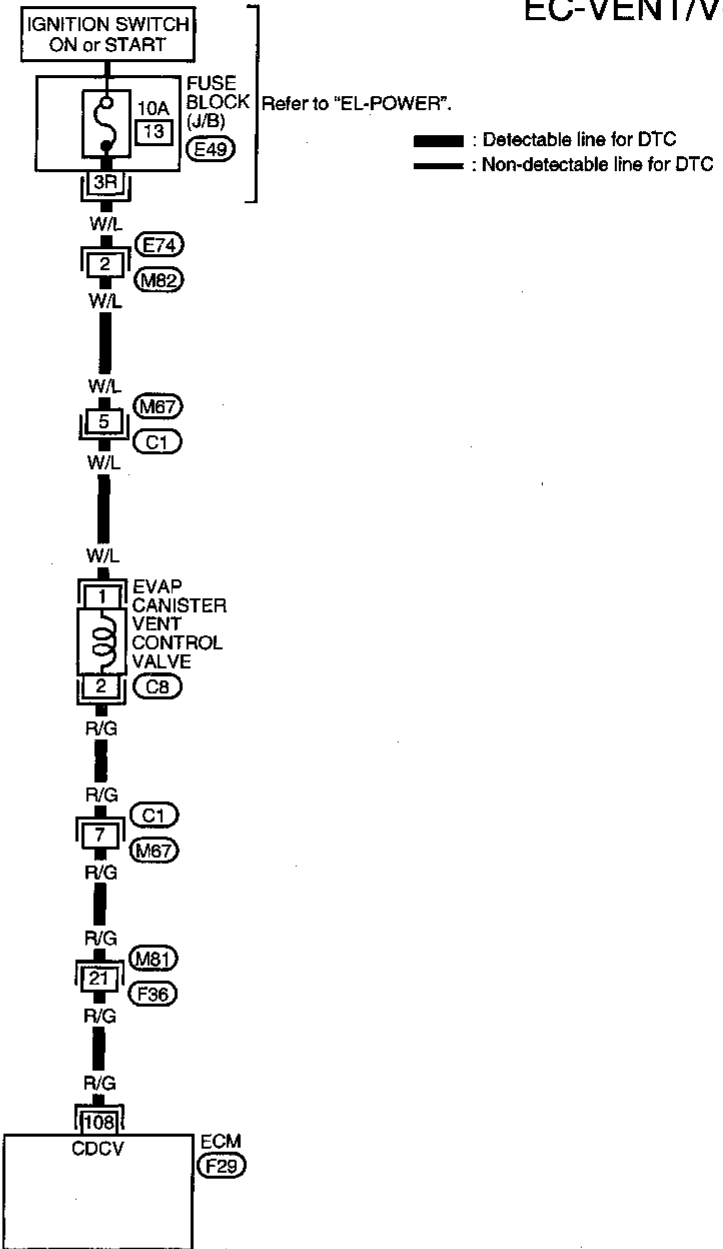

AEC744A

# DTC P1446 EVAPORATIVE EMISSION (EVAP) CANISTER VENT CONTROL VALVE (CLOSE)

Diagnostic Procedure

## Diagnostic Procedure

NEEC0490

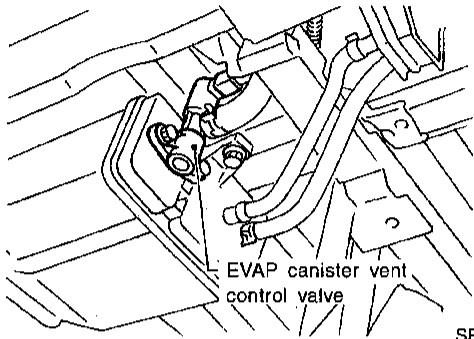
<b>1</b>	<b>CHECK RUBBER TUBE</b>
<p>1. Turn ignition switch "OFF".                  2. Check obstructed water separator and rubber tube connected to EVAP canister vent control valve.                  3. Clean the rubber tube using air blower. For water separator, refer to EC-413.</p>	
 <p style="text-align: right;">SEF143S</p>	
<b>OK or NG</b>	
OK	▶ GO TO 2.
NG	▶ Clean, repair or replace rubber tube and/or water separator.

<b>2</b>	<b>CHECK EVAP CANISTER VENT CONTROL VALVE AND O-RING</b>
Refer to "Component Inspection", EC-413.	
<b>OK or NG</b>	
OK	▶ GO TO 3.
NG	▶ Replace EVAP canister vent control valve and O-ring.

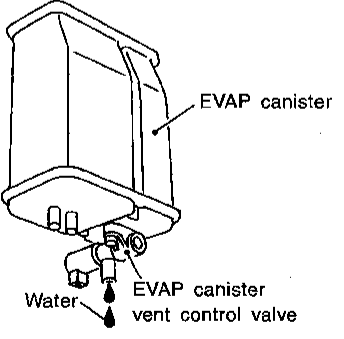
<b>3</b>	<b>CHECK IF EVAP CANISTER SATURATED WITH WATER</b>
<p>1. Remove EVAP canister with EVAP canister vent control valve attached.                  2. Check if water will drain from the EVAP canister.</p>	
 <p style="text-align: right;">SEF596U</p>	
<b>Yes or No</b>	
Yes	▶ GO TO 4.
No	▶ GO TO 6.

<b>4</b>	<b>CHECK EVAP CANISTER</b>
<p>Weigh the EVAP canister with the EVAP canister vent control valve attached.  <b>The weight should be less than 1.8 kg (4.0 lb).</b></p>	
<b>OK or NG</b>	
OK	▶ GO TO 6.
NG	▶ GO TO 5.

<b>5</b>	<b>DETECT MALFUNCTIONING PART</b>
<p>Check the following.</p> <ul style="list-style-type: none"> <li>• EVAP canister for damage</li> <li>• EVAP hose between EVAP canister and water separator for clogging or poor connection</li> </ul>	
▶ Repair hose or replace EVAP canister.	

<b>6</b>	<b>CHECK EVAP CONTROL SYSTEM PRESSURE SENSOR HOSE</b>
Check disconnection or improper connection of hose connected to EVAP control system pressure sensor.	
<b>OK or NG</b>	
OK	▶ GO TO 7.
NG	▶ Repair it.

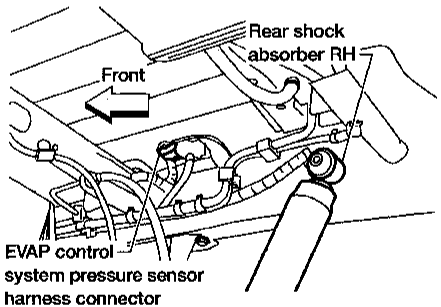
<b>7</b>	<b>CHECK CONNECTOR</b>
<p>1. Disconnect EVAP control system pressure sensor harness connector.</p>	
 <p style="text-align: right;">AEC651A</p>	
<p>2. Check connectors for water.  <b>Water should not exist.</b></p>	
<b>OK or NG</b>	
OK	▶ GO TO 8.
NG	▶ Replace EVAP control system pressure sensor.

# DTC P1446 EVAPORATIVE EMISSION (EVAP) CANISTER VENT CONTROL VALVE (CLOSE)

Diagnostic Procedure (Cont'd)

<b>8</b>	<b>CHECK EVAP CONTROL SYSTEM PRESSURE SENSOR FUNCTION</b>
Refer to "DTC Confirmation Procedure" for DTC P0450, EC-323.	
OK or NG	
OK	▶ GO TO 9.
NG	▶ Replace EVAP control system pressure sensor.

<b>9</b>	<b>CHECK INTERMITTENT INCIDENT</b>
Refer to "TROUBLE DIAGNOSIS FOR INTERMITTENT INCIDENT", EC-115.	
▶	<b>INSPECTION END</b>

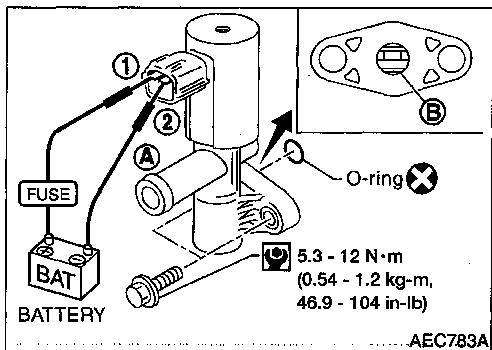
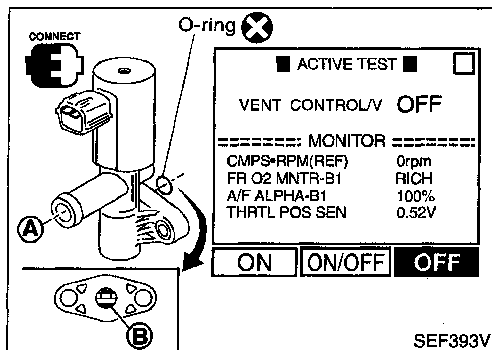

## Component Inspection

### EVAP CANISTER VENT CONTROL VALVE

NEEC0491

NEEC0491S01

Check air passage continuity.

#### ① With CONSULT

Perform "VENT CONTROL/V" in "ACTIVE TEST" mode.

Condition	Air passage continuity between A and B
VENT CONTROL/V	
ON	No
OFF	Yes

#### ② Without CONSULT

Condition	Air passage continuity between A and B
12V direct current supply between terminals 1 and 2	No
No supply	Yes

If NG or operation takes more than 1 second, clean valve using air blower or replace as necessary.

If portion B is rusted, replace control valve.

**Make sure new O-ring is installed properly.**

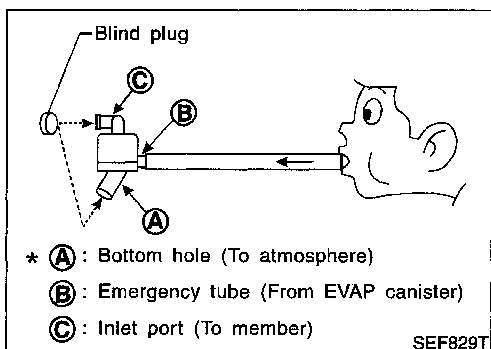

## WATER SEPARATOR

NEEC0491S02

1. Check visually for insect nests in the water separator air inlet.
2. Check visually for cracks or flaws in the appearance.
3. Check visually for cracks or flaws in the hose.
4. Check that A and C are not clogged by blowing air into B with A, and then C plugged.
5. In case of NG in items 2 - 4, replace the parts.

#### NOTE:

- Do not disassemble water separator.

# DTC P1447 EVAPORATIVE EMISSION (EVAP) CONTROL SYSTEM PURGE FLOW MONITORING

System Description

## System Description

NEEC0339

**NOTE:**

If DTC P1447 is displayed with P0510, perform trouble diagnosis for DTC P0510 first. (See EC-342.)

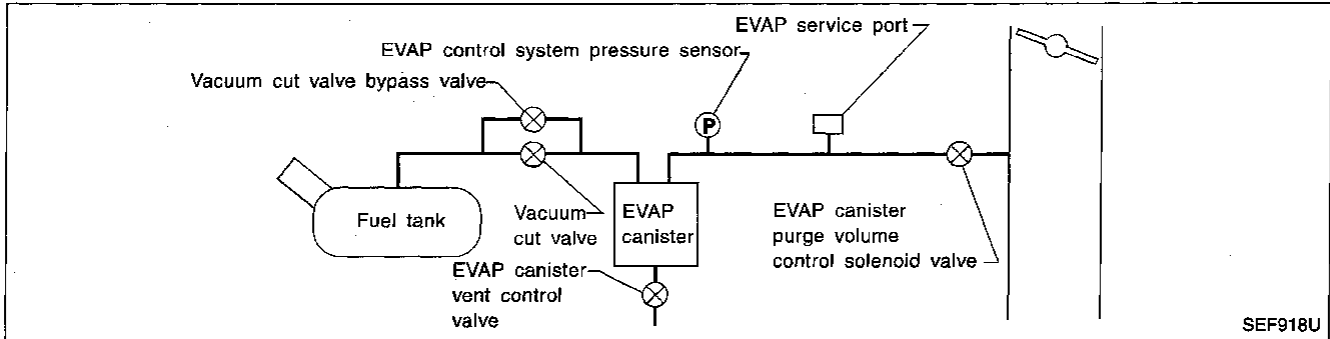

In this evaporative emission (EVAP) control system, purge flow occurs during non-closed throttle conditions. Purge volume is related to air intake volume. Under normal purge conditions (non-closed throttle), the EVAP canister purge volume control solenoid valve is open. Purge flow exposes the EVAP control system pressure sensor to intake manifold vacuum.

## On Board Diagnosis Logic

NEEC0394

Under normal conditions (non-closed throttle), sensor output voltage indicates if pressure drop and purge flow are adequate. If not, a fault is determined.

DTC No.	Malfunction is detected when ...	Check Items (Possible Cause)
P1447 0111	<ul style="list-style-type: none"> <li>• EVAP control system does not operate properly.</li> <li>• EVAP control system has a leak between intake manifold and EVAP control system pressure sensor.</li> </ul>	<ul style="list-style-type: none"> <li>• EVAP canister purge volume control solenoid valve stuck closed</li> <li>• EVAP control system pressure sensor and the circuit</li> <li>• Loose, disconnected or improper connection of rubber tube</li> <li>• Blocked rubber tube</li> <li>• Blocked or bent rubber tube to MAP/BARO switch solenoid valve</li> <li>• Cracked EVAP canister</li> <li>• EVAP canister purge volume control solenoid valve circuit</li> <li>• Closed throttle position switch</li> <li>• Blocked purge port</li> <li>• EVAP canister vent control valve</li> </ul>

# DTC P1447 EVAPORATIVE EMISSION (EVAP) CONTROL SYSTEM PURGE FLOW MONITORING

DTC Confirmation Procedure

NEEC0335

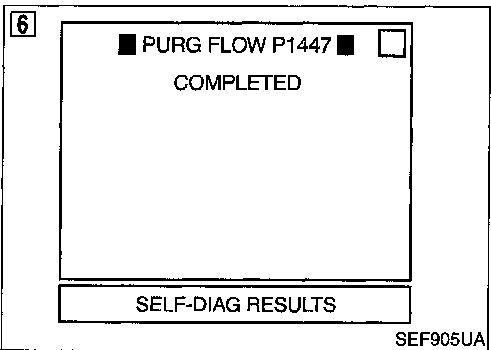
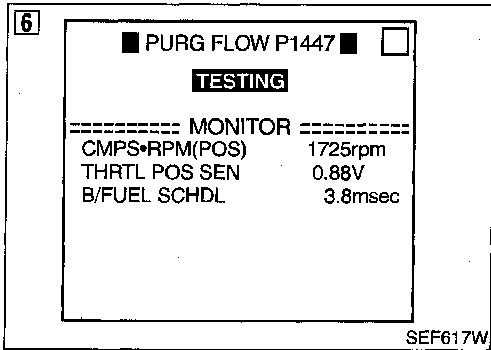
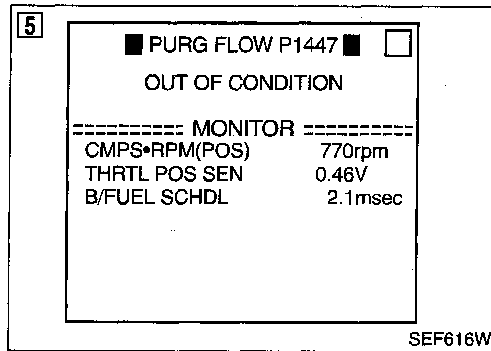

## DTC Confirmation Procedure

### CAUTION:

Always drive vehicle at a safe speed.

### NOTE:

If "DTC Confirmation Procedure" has been previously conducted, always turn ignition switch "OFF" and wait at least 5 seconds before conducting the next test.

### TESTING CONDITION:

Always perform test at a temperature of 5°C (41°F) or more.

#### Ⓢ With CONSULT

- 1) Start engine and warm it up to normal operating temperature.
- 2) Turn ignition switch "OFF" and wait at least 5 seconds.
- 3) Start engine and let it idle for at least 70 seconds.
- 4) Select "PURG FLOW P1447" of "EVAPORATIVE SYSTEM" in "DTC CONFIRMATION" mode with CONSULT.
- 5) Touch "START".  
If "COMPLETED" is displayed, go to step 7.
- 6) When the following conditions are met, "TESTING" will be displayed on the CONSULT screen. Maintain the conditions continuously until "TESTING" changes to "COMPLETED". (It will take at least 35 seconds.)

Selector lever	Suitable position
Vehicle speed	32 - 120 km/h (20 - 75 MPH)
CMPS•RPM (POS)	500 - 3,400 rpm
B/FUEL SCHDL	Less than 4 msec
Engine coolant temperature	70 - 100°C (158 - 212°F)

If "TESTING" is not changed for a long time, retry from step 2.

- 7) Make sure that "OK" is displayed after touching "SELF-DIAG RESULTS". If "NG" is displayed, refer to "Diagnostic Procedure", EC-417.

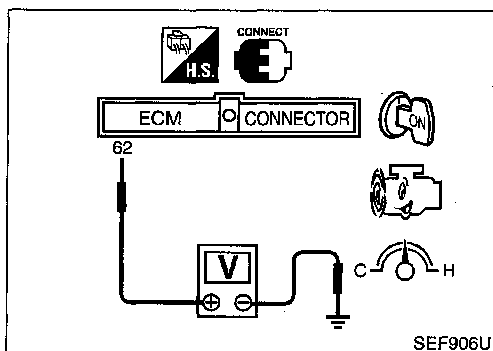

## Overall Function Check

NEEC0192

Use this procedure to check the overall monitoring function of the EVAP control system purge flow monitoring. During this check, a 1st trip DTC might not be confirmed.

#### Ⓢ Without CONSULT

- 1) Lift up drive wheels.
- 2) Start engine and warm it up to normal operating temperature.
- 3) Turn ignition switch "OFF", wait at least 5 seconds.
- 4) Start engine and wait at least 70 seconds.
- 5) Set voltmeter probes to ECM terminals 62 (EVAP control system pressure sensor signal) and ground.

EC-415

# DTC P1447 EVAPORATIVE EMISSION (EVAP) CONTROL SYSTEM PURGE FLOW MONITORING

## Overall Function Check (Cont'd)

- 6) Check EVAP control system pressure sensor value at idle speed and note it.
- 7) Establish and maintain the following conditions for at least 1 minute.

Air conditioner switch	ON
Steering wheel	Fully turned
Headlamp switch	ON
Rear window defogger switch	ON
Engine speed	Approx. 3,000 rpm
Gear position	Any position other than "P", "N" or "R"

- 8) Verify that EVAP control system pressure sensor value stays 0.1V less than the value at idle speed (measured at step 6) for at least 1 second.
- 9) If NG, go to "Diagnostic Procedure", EC-417.

# DTC P1447 EVAPORATIVE EMISSION (EVAP) CONTROL SYSTEM PURGE FLOW MONITORING

Diagnostic Procedure

-NEEC0336

## Diagnostic Procedure

1 CHECK EVAP CANISTER	
1. Turn ignition switch "OFF". 2. Check EVAP canister for cracks.	
<b>OK or NG</b>	
OK (With CONSULT) ▶	GO TO 2.
OK (Without CONSULT) ▶	GO TO 3.
NG ▶	Replace EVAP canister.

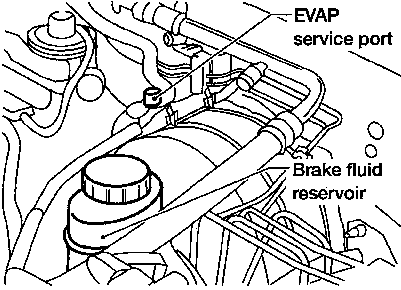
2 CHECK PURGE FLOW																									
<input checked="" type="checkbox"/> <b>With CONSULT</b> 1. Disconnect vacuum hose connected to EVAP canister purge volume control solenoid valve at EVAP service port and install vacuum gauge.																									
 <p style="text-align: right;">AEC649A</p>																									
2. Start engine and let it idle. 3. Select "PURG VOL CONT/V" in "ACTIVE TEST" mode with CONSULT. 4. Rev engine up to 2,000 rpm. 5. Touch "Qd" and "Qu" on CONSULT screen to adjust "PURG VOL CONT/V" opening.																									
<table border="1" style="width: 100%;"> <tr> <td colspan="2" style="text-align: center;">■ ACTIVE TEST ■</td> </tr> <tr> <td>PURG VOL CONT/V</td> <td style="text-align: right;">0.0%</td> </tr> <tr> <td colspan="2" style="text-align: center;">===== MONITOR =====</td> </tr> <tr> <td>CMPS•RPM(REF)</td> <td style="text-align: right;">2187rpm</td> </tr> <tr> <td>FR O2 MNTR-B2</td> <td style="text-align: right;">LEAN</td> </tr> <tr> <td>FR O2 MNTR-B1</td> <td style="text-align: right;">LEAN</td> </tr> <tr> <td>A/F ALPHA-B2</td> <td style="text-align: right;">91%</td> </tr> <tr> <td>A/F ALPHA-B1</td> <td style="text-align: right;">90%</td> </tr> <tr> <td>THRTL POS SEN</td> <td style="text-align: right;">0.64V</td> </tr> <tr> <td>Qu</td> <td style="text-align: right;">UP</td> </tr> <tr> <td></td> <td style="text-align: right;">DWN</td> </tr> <tr> <td></td> <td style="text-align: right;">Qd</td> </tr> </table> <p style="text-align: right;">SEF908U</p>		■ ACTIVE TEST ■		PURG VOL CONT/V	0.0%	===== MONITOR =====		CMPS•RPM(REF)	2187rpm	FR O2 MNTR-B2	LEAN	FR O2 MNTR-B1	LEAN	A/F ALPHA-B2	91%	A/F ALPHA-B1	90%	THRTL POS SEN	0.64V	Qu	UP		DWN		Qd
■ ACTIVE TEST ■																									
PURG VOL CONT/V	0.0%																								
===== MONITOR =====																									
CMPS•RPM(REF)	2187rpm																								
FR O2 MNTR-B2	LEAN																								
FR O2 MNTR-B1	LEAN																								
A/F ALPHA-B2	91%																								
A/F ALPHA-B1	90%																								
THRTL POS SEN	0.64V																								
Qu	UP																								
	DWN																								
	Qd																								
100.0%: Vacuum should exist. 0.0%: Vacuum should not exist.																									
<b>OK or NG</b>																									
OK ▶	GO TO 7.																								
NG ▶	GO TO 4.																								

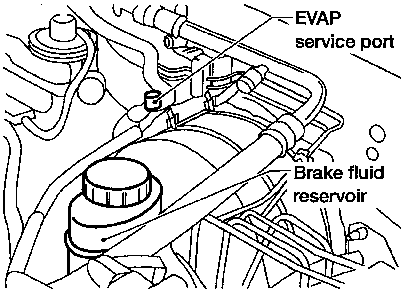
3 CHECK PURGE FLOW	
<input checked="" type="checkbox"/> <b>Without CONSULT</b> 1. Start engine and warm it up to normal operating temperature. 2. Stop engine. 3. Disconnect vacuum hose connected to EVAP canister purge volume control solenoid valve at EVAP service port and install vacuum gauge.	
 <p style="text-align: right;">AEC649A</p>	
4. Start engine and let it idle for at least 80 seconds. 5. Check vacuum gauge indication when revving engine up to 2,000 rpm. <b>Vacuum should exist.</b> 6. Release the accelerator pedal fully and let idle. <b>Vacuum should not exist.</b>	
<b>OK or NG</b>	
OK ▶	GO TO 7.
NG ▶	GO TO 4.

4 CHECK EVAP PURGE LINE	
1. Turn ignition switch "OFF". 2. Check EVAP purge line for improper connection or disconnection. Refer to "EVAPORATIVE EMISSION LINE DRAWING", EC-28.	
<b>OK or NG</b>	
OK ▶	GO TO 5.
NG ▶	Repair it.

GI  
MA  
EM  
LC  
EC  
FE  
CL  
MT  
AT  
TF  
PD  
FA  
RA  
BR  
ST  
RS  
BT  
HA  
EL  
IDX

# DTC P1447 EVAPORATIVE EMISSION (EVAP) CONTROL SYSTEM PURGE FLOW MONITORING

Diagnostic Procedure (Cont'd)

<b>5</b>	<b>CHECK EVAP PURGE HOSE AND PURGE PORT</b>
<p>1. Disconnect purge hoses connected to EVAP service port <b>A</b> and EVAP canister purge volume control solenoid valve <b>B</b>.</p>	
<p style="text-align: center;">EVAP service port</p> <p style="text-align: center;">EVAP canister purge volume control solenoid valve</p> <p style="text-align: center;">Intake manifold</p>	
<p>2. Blow air into each hose and EVAP purge port <b>C</b>.</p> <p>3. Check that air flows freely.</p>	
<p style="text-align: center;">Intake manifold</p>	
SEF367U	
OK or NG	
OK	▶ GO TO 6.
NG	▶ Repair or clean hoses and/or purge port.

<b>6</b>	<b>CHECK EVAP CANISTER PURGE VOLUME CONTROL SOLENOID VALVE</b>
<p>Refer to "Component Inspection", EC-408.</p>	
OK or NG	
OK	▶ GO TO 7.
NG	▶ Replace EVAP canister purge volume control solenoid valve.

<b>7</b>	<b>CHECK EVAP CONTROL SYSTEM PRESSURE SENSOR HOSE</b>
<p>1. Turn ignition switch "OFF".</p> <p>2. Check disconnection or improper connection of hose connected to EVAP control system pressure sensor.</p>	
OK or NG	
OK	▶ GO TO 8.
NG	▶ Repair it.

<b>8</b>	<b>CHECK CONNECTOR</b>
<p>1. Disconnect EVAP control system pressure sensor harness connector.</p>	
<p style="text-align: center;">Rear shock absorber RH</p> <p style="text-align: center;">Front</p> <p style="text-align: center;">EVAP control system pressure sensor harness connector</p>	
<p>2. Check connectors for water. Water should not exist.</p>	
AEC651A	
OK or NG	
OK	▶ GO TO 9.
NG	▶ Replace EVAP control system pressure sensor.

<b>9</b>	<b>CHECK EVAP CONTROL SYSTEM PRESSURE SENSOR FUNCTION</b>
<p>Refer to "DTC Confirmation Procedure" for DTC P0450, EC-323.</p>	
OK or NG	
OK	▶ GO TO 10.
NG	▶ Replace EVAP control system pressure sensor.

<b>10</b>	<b>CHECK EVAP CANISTER VENT CONTROL VALVE</b>
<p>Refer to "Component Inspection", EC-413.</p>	
OK or NG	
OK	▶ GO TO 11.
NG	▶ Replace EVAP canister vent control valve.

<b>11</b>	<b>CHECK CLOSED THROTTLE POSITION SWITCH</b>
<p>Refer to "Component Inspection", EC-346.</p>	
OK or NG	
OK	▶ GO TO 12.
NG	▶ Replace throttle position switch with throttle position sensor.



# DTC P1447 EVAPORATIVE EMISSION (EVAP) CONTROL SYSTEM PURGE FLOW MONITORING

Diagnostic Procedure (Cont'd)

<b>12</b>	<b>CHECK EVAP PURGE LINE</b>
Inspect EVAP purge line (pipe and rubber tube). Check for evidence of leaks. Refer to "EVAPORATIVE EMISSION LINE DRAWING", EC-28.	
<b>OK or NG</b>	
OK	▶ GO TO 13.
NG	▶ Replace it.

<b>13</b>	<b>CLEAN EVAP PURGE LINE</b>
Clean EVAP purge line (pipe and rubber tube) using air blower.	
	▶ GO TO 14.

<b>14</b>	<b>CHECK INTERMITTENT INCIDENT</b>
Refer to "TROUBLE DIAGNOSIS FOR INTERMITTENT INCIDENT", EC-115.	
	▶ INSPECTION END

GI  
MA  
EM  
LC  
**EC**  
FE  
CL  
MT  
AT  
TF  
PD  
FA  
RA  
BR  
ST  
RS  
BT  
HA  
EL  
IDX

# DTC P1448 EVAPORATIVE EMISSION (EVAP) CANISTER VENT CONTROL VALVE (OPEN)

## Component Description

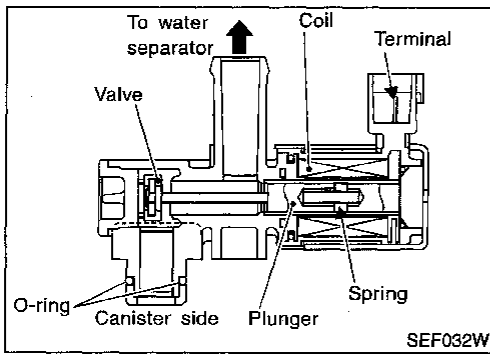

SEF032W

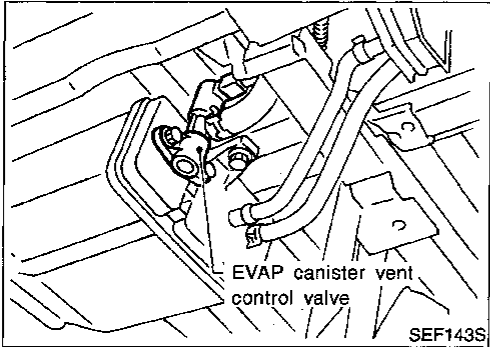

SEF143S

## Component Description

NEEC0493

### NOTE:

If DTC P1448 is displayed with P0440, perform trouble diagnosis for DTC P1448 first.

The EVAP canister vent control valve is located on the EVAP canister and is used to seal the canister vent.

This solenoid valve responds to signals from the ECM. When the ECM sends an ON signal, the coil in the solenoid valve is energized. A plunger will then move to seal the canister vent. The ability to seal the vent is necessary for the on board diagnosis of other evaporative emission control system components.

This solenoid valve is used only for diagnosis, and usually remains opened.

When the vent is closed, under normal purge conditions, the evaporative emission control system is depressurized and allows "EVAP Control System (Small Leak)" diagnosis.

## CONSULT Reference Value in Data Monitor Mode

NEEC0494

Specification data are reference values.

MONITOR ITEM	CONDITION	SPECIFICATION
VENT CONT/V	• Ignition switch: ON	OFF

## ECM Terminals and Reference Value

NEEC0495

Specification data are reference values and are measured between each terminal and 32 (ECM ground).

TERMI-NAL NO.	WIRE COLOR	ITEM	CONDITION	DATA (DC Voltage)
108	R/G	EVAP canister vent control valve	[Ignition switch "ON"]	BATTERY VOLTAGE (11 - 14V)

## On Board Diagnosis Logic

NEEC0496

DTC No.	Malfunction is detected when ...	Check Items (Possible Cause)
P1448 0309	<ul style="list-style-type: none"> <li>• EVAP canister vent control valve remains opened under specified driving conditions.</li> </ul>	<ul style="list-style-type: none"> <li>• EVAP canister vent control valve</li> <li>• EVAP control system pressure sensor and circuit</li> <li>• Blocked rubber tube to EVAP canister vent control valve</li> <li>• Water separator</li> <li>• EVAP canister is saturated with water.</li> <li>• Vacuum cut valve</li> </ul>

# DTC P1448 EVAPORATIVE EMISSION (EVAP) CANISTER VENT CONTROL VALVE (OPEN)

DTC Confirmation Procedure

## DTC Confirmation Procedure

NEEC0497

### NOTE:

- If DTC P1448 is displayed with P0440, perform trouble diagnosis for DTC P1448 first.
- If "DTC Confirmation Procedure" has been previously conducted, always turn ignition switch "OFF" and wait at least 5 seconds before conducting the next test.

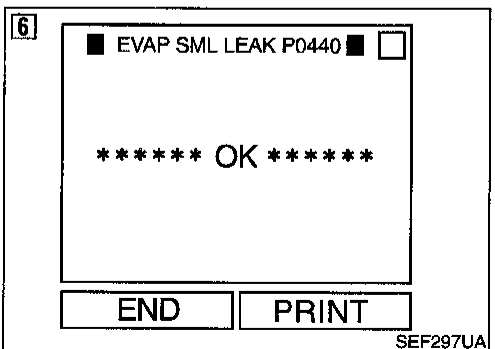
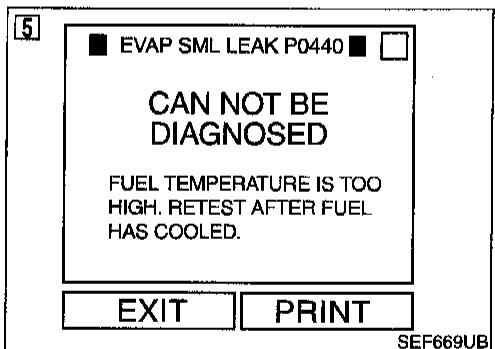
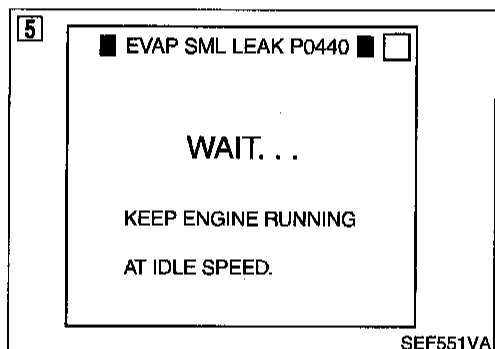
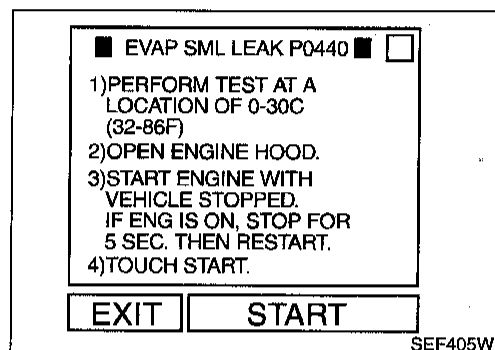

### Ⓟ With CONSULT

#### TESTING CONDITION:

- Perform "DTC WORK SUPPORT" when the fuel level is less than 3/4 full and vehicle is placed on flat level surface.
  - Always perform test at a temperature of 0 to 30°C (32 to 86°F).
  - It is better that the fuel level is low.
- 1) Turn ignition switch "ON".
  - 2) Turn ignition switch "OFF" and wait at least 5 seconds.
  - 3) Turn ignition switch "ON" and select "DATA MONITOR" mode with CONSULT.
  - 4) Make sure that the following conditions are met.

COOLAN TEMP/S	0 - 70°C (32 - 158°F)
INT/A TEMP SE	0 - 60°C (32 - 140°F)

- 5) Select "EVAP SML LEAK P0440" of "EVAPORATIVE SYSTEM" in "DTC WORK SUPPORT" mode with CONSULT. Follow the instruction displayed.

#### NOTE:

- If the CONSULT screen shown at left is displayed, stop the engine and stabilize the vehicle temperature at 25°C (77°F) or cooler. After "TANK F/TMP SE" becomes less than 30°C (86°F), retest. (Use a fan to reduce the stabilization time.)
  - If the engine speed cannot be maintained within the range displayed on the CONSULT screen, go to "Basic Inspection", EC-86.
  - The engine idle portion of this test (See illustration at left.) will take approximately 5 minutes.
- 6) Make sure that "OK" is displayed. If "NG" is displayed, go to the following step.

#### NOTE:

Make sure that EVAP hoses are connected to EVAP canister purge volume control solenoid valve properly.

- 7) Stop engine and wait at least 5 seconds, then turn "ON".
- 8) Disconnect hose from water separator.
- 9) Select "VENT CONTROL/V" of "ACTIVE TEST" mode with CONSULT.
- 10) Touch "ON" and "OFF" alternately.

GI  
MA  
EM  
LC  
EC  
FE  
CL  
MT  
AT  
TF  
PD  
FA  
RA  
BR  
ST  
RS  
BT  
HA  
EL  
IDX

# DTC P1448 EVAPORATIVE EMISSION (EVAP) CANISTER VENT CONTROL VALVE (OPEN)

DTC Confirmation Procedure (Cont'd)

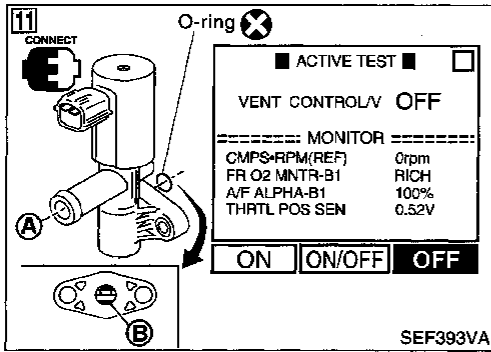

11) Make sure the following.

Condition VENT CONTROL/V	Air passage continuity between A and B
ON	No
OFF	Yes

If the result is NG, go to "Diagnostic Procedure", EC-424.  
If the result is OK, go to "Diagnostic Procedure" for DTC P0440, EC-305.

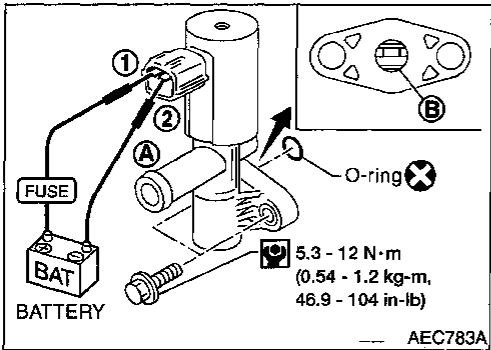

## Overall Function Check

Use this procedure to check the overall function of the EVAP canister vent control valve circuit. During this check, a DTC might not be confirmed. NEEC0498

**Without CONSULT**

- 1) Disconnect hose from water separator.
- 2) Disconnect EVAP canister vent control valve harness connector.
- 3) Verify the following.

Condition	Air passage continuity
12V direct current supply between terminals 1 and 2	No
No supply	Yes

If the result is NG, go to "Diagnostic Procedure", EC-424.  
If the result is OK, go to "Diagnostic Procedure" for DTC P0440, EC-305.

# DTC P1448 EVAPORATIVE EMISSION (EVAP) CANISTER VENT CONTROL VALVE (OPEN)

Wiring Diagram

## Wiring Diagram

NEEC0499

### EC-VENT/V-01

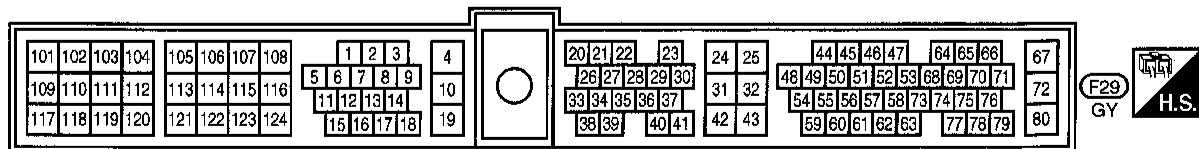
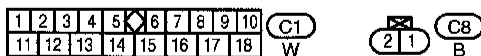
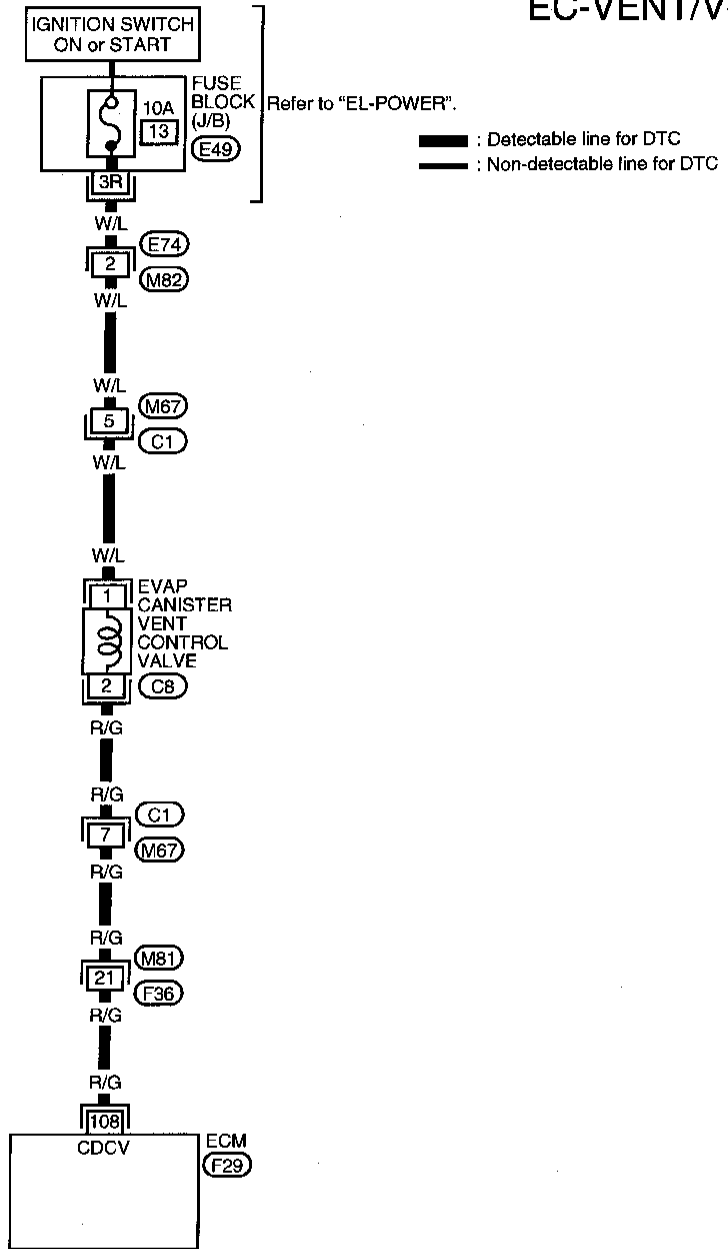

AEC744A

# DTC P1448 EVAPORATIVE EMISSION (EVAP) CANISTER VENT CONTROL VALVE (OPEN)

Diagnostic Procedure

## Diagnostic Procedure

NEEC0500

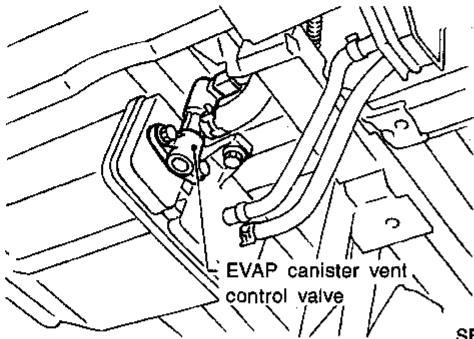
<b>1</b>	<b>CHECK RUBBER TUBE</b>
<ol style="list-style-type: none"> <li>Turn ignition switch "OFF".</li> <li>Check obstructed water separator and rubber tube connected to EVAP canister vent control valve.</li> <li>Clean the rubber tube using air blower. For water separator, refer to EC-426.</li> </ol>	
	
SEF143S	
<b>OK or NG</b>	
OK	▶ GO TO 2.
NG	▶ Clean, repair or replace rubber tube and/or water separator.

<b>2</b>	<b>CHECK EVAP CANISTER VENT CONTROL VALVE AND O-RING</b>
Refer to "Component Inspection", EC-425.	
<b>OK or NG</b>	
OK	▶ GO TO 3.
NG	▶ Replace EVAP canister vent control valve and O-ring.

<b>3</b>	<b>CHECK VACUUM CUT VALVE</b>
Refer to "Component Inspection", EC-438.	
<b>OK or NG</b>	
OK	▶ GO TO 4.
NG	▶ Replace vacuum cut valve.

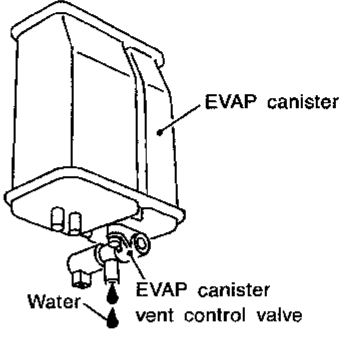
<b>4</b>	<b>CHECK IF EVAP CANISTER SATURATED WITH WATER</b>
<ol style="list-style-type: none"> <li>Remove EVAP canister with EVAP canister vent control valve attached.</li> <li>Check if water will drain from the EVAP canister.</li> </ol>	
	
SEF596U	
<b>OK or NG</b>	
OK	▶ GO TO 5.
NG	▶ GO TO 7.

<b>5</b>	<b>CHECK EVAP CANISTER</b>
Weigh the EVAP canister with the EVAP canister vent control valve attached.	
<b>The weight should be less than 1.8 kg (4.0 lb).</b>	
<b>OK or NG</b>	
OK	▶ GO TO 7.
NG	▶ Replace the EVAP canister.

<b>6</b>	<b>DETECT MALFUNCTIONING PART</b>
Check the following.	
<ul style="list-style-type: none"> <li>EVAP canister for damage</li> <li>EVAP hose between EVAP canister and water separator for clogging or poor connection</li> </ul>	
▶ Repair hose or replace EVAP canister.	

<b>7</b>	<b>CHECK EVAP CONTROL SYSTEM PRESSURE SENSOR HOSE</b>
Check disconnection or improper connection of hose connected to EVAP control system pressure sensor.	
<b>OK or NG</b>	
OK	▶ GO TO 8.
NG	▶ Repair it.

# DTC P1448 EVAPORATIVE EMISSION (EVAP) CANISTER VENT CONTROL VALVE (OPEN)

Diagnostic Procedure (Cont'd)

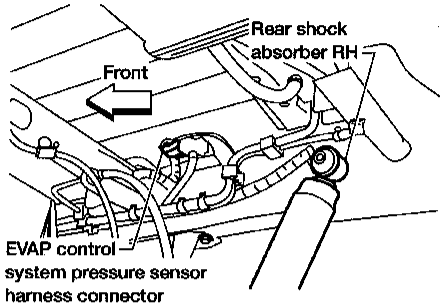
<b>8</b>	<b>CHECK CONNECTOR</b>
<p>1. Disconnect EVAP control system pressure sensor harness connector.</p>  <p style="text-align: right;">AEC651A</p>	
<p>2. Check connectors for water. Water should not exist.</p> <p style="text-align: center;"><b>OK or NG</b></p>	
OK	▶ GO TO 9.
NG	▶ Replace EVAP control system pressure sensor.

<b>9</b>	<b>CHECK EVAP CONTROL SYSTEM PRESSURE SENSOR FUNCTION</b>
<p>Refer to "DTC Confirmation Procedure" for DTC P0450, EC-323.</p> <p style="text-align: center;"><b>OK or NG</b></p>	
OK	▶ GO TO 10.
NG	▶ Replace EVAP control system pressure sensor.

<b>10</b>	<b>CHECK INTERMITTENT INCIDENT</b>
<p>Refer to "TROUBLE DIAGNOSIS FOR INTERMITTENT INCIDENT", EC-115.</p> <p style="text-align: right;">▶ <b>INSPECTION END</b></p>	

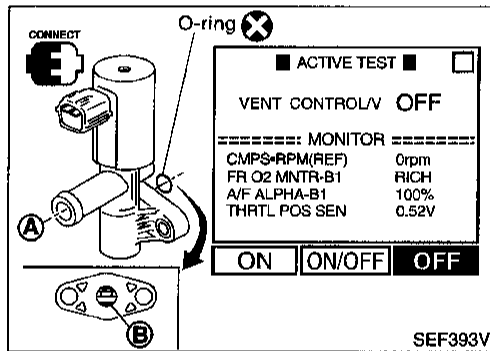

SEF393V

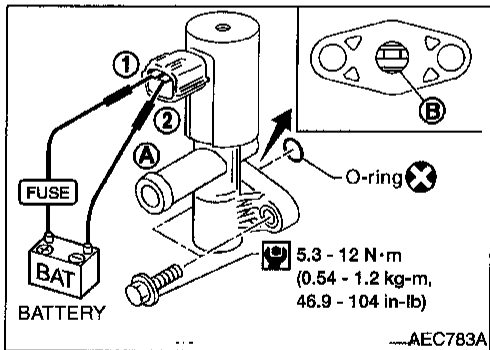

AEC783A

## Component Inspection

### EVAP CANISTER VENT CONTROL VALVE

NEEC0501

NEEC0601S01

Check air passage continuity.

#### Ⓐ With CONSULT

Perform "VENT CONTROL/V" in "ACTIVE TEST" mode.

Condition VENT CONTROL/V	Air passage continuity between A and B
ON	No
OFF	Yes

#### Ⓑ Without CONSULT

Condition	Air passage continuity between A and B
12V direct current supply between terminals 1 and 2	No
No supply	Yes

If NG or operation takes more than 1 second, clean valve using air blower or replace as necessary.

If portion B is rusted, replace control valve.

**Make sure new O-ring is installed properly.**

# DTC P1448 EVAPORATIVE EMISSION (EVAP) CANISTER VENT CONTROL VALVE (OPEN)

## Component Inspection (Cont'd)

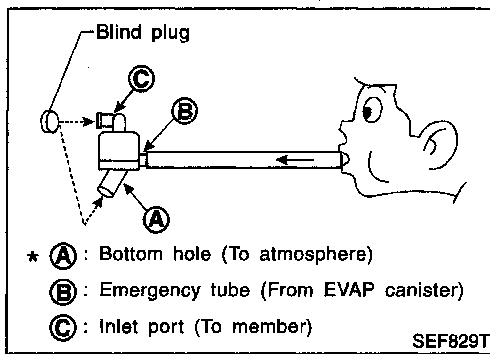

### WATER SEPARATOR

NEEC0501302

1. Check visually for insect nests in the water separator air inlet.
2. Check visually for cracks or flaws in the appearance.
3. Check visually for cracks or flaws in the hose.
4. Check that **A** and **C** are not clogged by blowing air into **B** with **A**, and then **C** plugged.
5. In case of NG in items 2 - 4, replace the parts.

#### NOTE:

- Do not disassemble water separator.



# DTC P1490 VACUUM CUT VALVE BYPASS VALVE (CIRCUIT)

Description

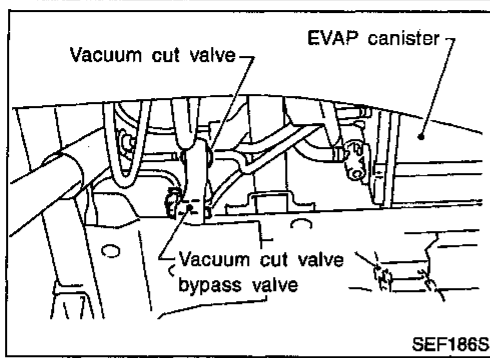

## Description

### COMPONENT DESCRIPTION

The vacuum cut valve and vacuum cut valve bypass valve are installed in parallel on the EVAP purge line between the fuel tank and the EVAP canister.

The vacuum cut valve prevents the intake manifold vacuum from being applied to the fuel tank.

The vacuum cut valve bypass valve is a solenoid type valve and generally remains closed. It opens only for on board diagnosis.

The vacuum cut valve bypass valve responds to signals from the ECM. When the ECM sends an ON (ground) signal, the valve is opened. The vacuum cut valve is then bypassed to apply intake manifold vacuum to the fuel tank.

### EVAPORATIVE EMISSION SYSTEM DIAGRAM

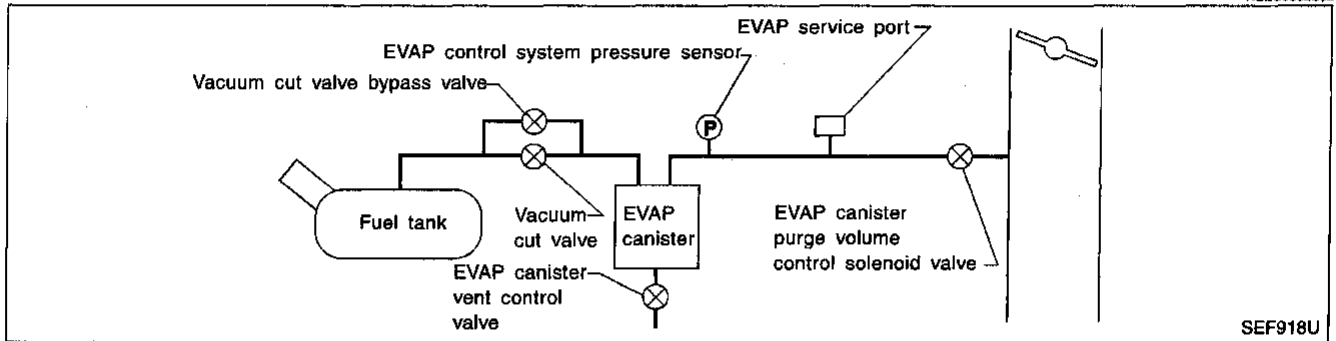

## CONSULT Reference Value in Data Monitor Mode

Specification data are reference values.

MONITOR ITEM	CONDITION	SPECIFICATION
VC/V BYPASS/V	• Ignition switch: ON	OFF

## ECM Terminals and Reference Value

Specification data are reference values and are measured between each terminal and 32 (ECM ground).

TERMI- NAL NO.	WIRE COLOR	ITEM	CONDITION	DATA (DC Voltage)
120	P/B	Vacuum cut valve bypass valve	[Ignition switch "ON"]	BATTERY VOLTAGE (11 - 14V)

# DTC P1490 VACUUM CUT VALVE BYPASS VALVE (CIRCUIT)

On Board Diagnosis Logic

## On Board Diagnosis Logic

NEEC0505

DTC No.	Malfunction is detected when ...	Check Items (Possible Cause)
P1490 0801	An improper voltage signal is sent to ECM through vacuum cut valve bypass valve.	<ul style="list-style-type: none"><li>• Harness or connectors (The vacuum cut valve bypass valve circuit is open or shorted.)</li><li>• Vacuum cut valve bypass valve</li></ul>

## DTC Confirmation Procedure

NEEC0506

### NOTE:

If "DTC Confirmation Procedure" has been previously conducted, always turn ignition switch "OFF" and wait at least 5 seconds before conducting the next test.

### TESTING CONDITION:

Before performing the following procedure, confirm that battery voltage is more than 11V at idle speed.

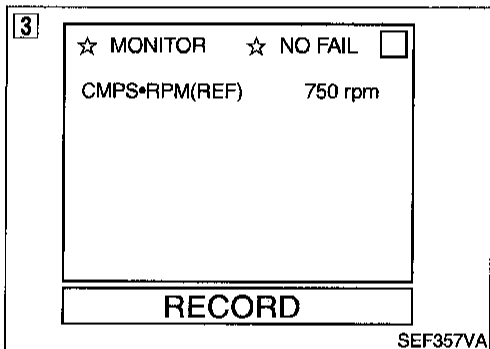

### ③ With CONSULT

- 1) Turn ignition switch "ON".
- 2) Select "DATA MONITOR" mode with CONSULT.
- 3) Start engine and wait at least 5 seconds.
- 4) If 1st trip DTC is detected, go to "Diagnostic Procedure", EC-430.

### ④ With GST

- 1) Start engine and wait at least 5 seconds.
- 2) Select "MODE 7" with GST.
- 3) If 1st trip DTC is detected, go to "Diagnostic Procedure", EC-430.

### ⑤ No Tools

- 1) Start engine and wait at least 5 seconds.
- 2) Turn ignition switch "OFF", wait at least 5 seconds and then turn "ON".
- 3) Perform "Diagnostic Test Mode II (Self-diagnostic results)" with ECM.
- 4) If 1st trip DTC is detected, go to "Diagnostic Procedure", EC-430.

# DTC P1490 VACUUM CUT VALVE BYPASS VALVE (CIRCUIT)

Wiring Diagram

## Wiring Diagram

NEEC0507

### EC-BYPS/V-01

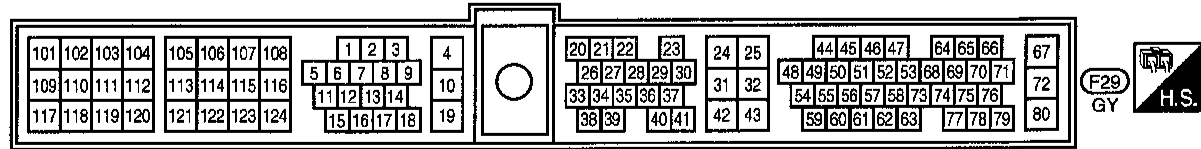
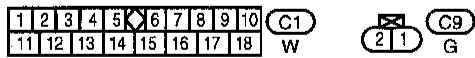
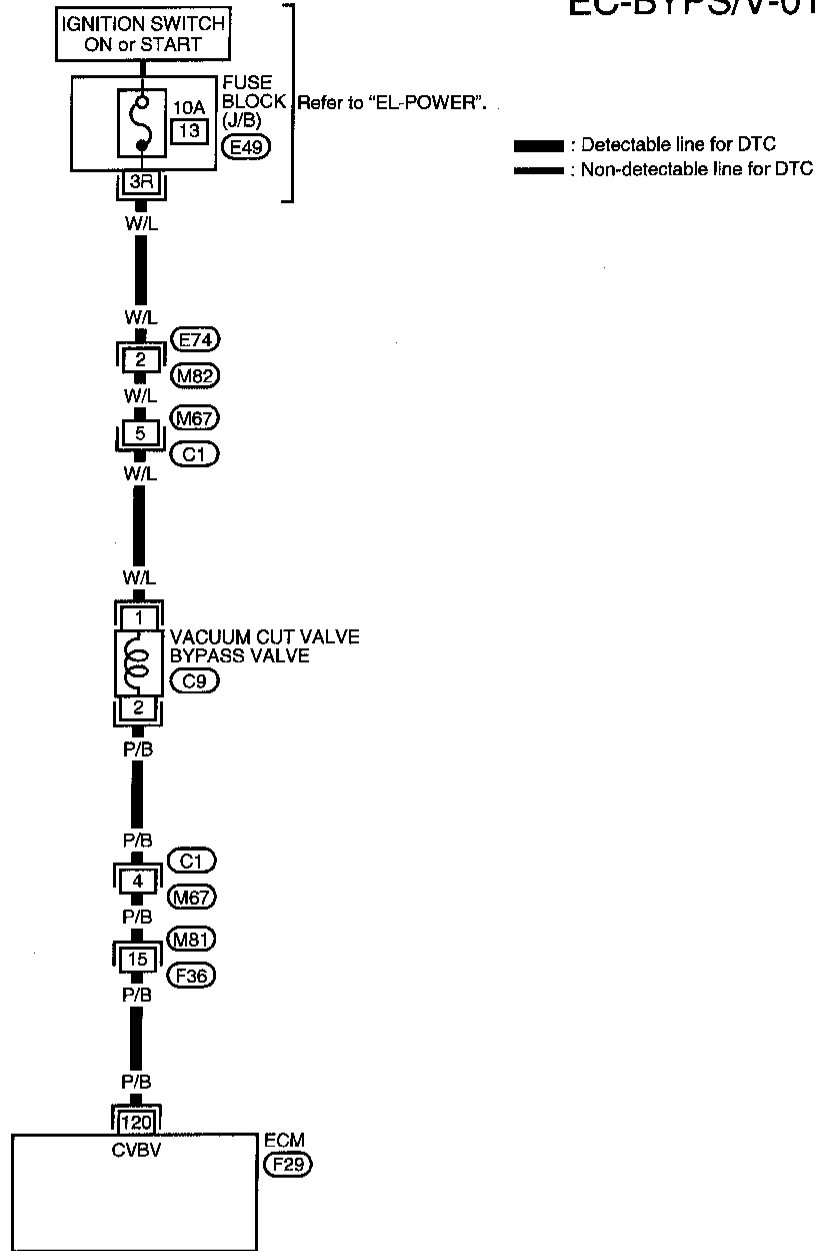

AEC749A

EC-429

# DTC P1490 VACUUM CUT VALVE BYPASS VALVE (CIRCUIT)

Diagnostic Procedure

## Diagnostic Procedure

NEEC0508

<b>1</b>	<b>INSPECTION START</b>	
Do you have CONSULT?		
Yes or No		
Yes	▶	GO TO 2.
No	▶	GO TO 3.

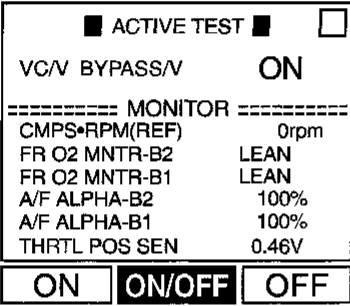
<b>2</b>	<b>CHECK VACUUM CUT VALVE BYPASS VALVE CIRCUIT</b>	
<p><b>With CONSULT</b></p> <ol style="list-style-type: none"> <li>Turn ignition switch "OFF" and then "ON".</li> <li>Select "VC/V BYPASS/V" in "ACTIVE TEST" mode with CONSULT.</li> <li>Touch "ON/OFF" on CONSULT screen.</li> </ol>		
		
<p>4. Make sure that clicking sound is heard from the vacuum cut valve bypass valve.</p>		
OK or NG		
OK	▶	GO TO 7.
NG	▶	GO TO 3.

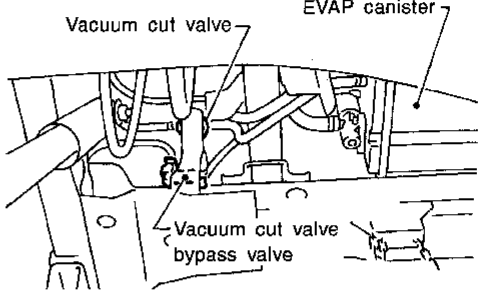
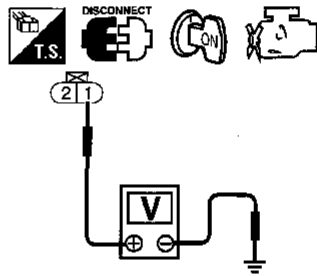
<b>3</b>	<b>CHECK POWER SUPPLY</b>	
<p><b>Without CONSULT</b></p> <ol style="list-style-type: none"> <li>Turn ignition switch "OFF".</li> <li>Disconnect vacuum cut valve bypass valve harness connector.</li> </ol>		
		
SEF186S		
<ol style="list-style-type: none"> <li>Turn ignition switch "ON".</li> <li>Check voltage between terminal 1 and ground with CONSULT or tester.</li> </ol>		
		
Voltage: Battery voltage		
OK or NG		
OK	▶	GO TO 5.
NG	▶	GO TO 4.

<b>4</b>	<b>DETECT MALFUNCTIONING PART</b>	
<p>Check the following.</p> <ul style="list-style-type: none"> <li>Harness connectors E74, M82</li> <li>Harness connectors M67, C1</li> <li>Fuse block (J/B) connector E49</li> <li>10A fuse</li> <li>Harness for open or short between vacuum cut valve bypass valve and fuse</li> </ul>		
▶		Repair harness or connectors.

# DTC P1490 VACUUM CUT VALVE BYPASS VALVE (CIRCUIT)

Diagnostic Procedure (Cont'd)

<b>5</b>	<b>CHECK OUTPUT SIGNAL CIRCUIT</b>						
<ol style="list-style-type: none"> <li>Turn ignition switch "OFF".</li> <li>Disconnect ECM harness connector.</li> <li>Check harness continuity between ECM terminal 120 and terminal 2.</li> </ol>							
<p>Continuity should exist.</p> <p>4. Also check harness for short to ground and short to power.</p>							
<p><b>OK or NG</b></p> <table border="1"> <tr> <td>OK</td> <td>▶</td> <td>GO TO 7.</td> </tr> <tr> <td>NG</td> <td>▶</td> <td>GO TO 6.</td> </tr> </table>		OK	▶	GO TO 7.	NG	▶	GO TO 6.
OK	▶	GO TO 7.					
NG	▶	GO TO 6.					

<b>6</b>	<b>DETECT MALFUNCTIONING PART</b>
<p>Check the following.</p> <ul style="list-style-type: none"> <li>Harness connectors C1, M67</li> <li>Harness connectors M81, F36</li> <li>Harness for open or short between vacuum cut valve bypass valve and ECM</li> </ul>	
<p>▶ Repair open circuit or short to ground or short to power in harness or connectors.</p>	

<b>7</b>	<b>CHECK VACUUM CUT VALVE BYPASS VALVE</b>	
Refer to "Component Inspection", EC-431.		
<b>OK or NG</b>		
OK	▶	GO TO 8.
NG	▶	Replace vacuum cut valve bypass valve.

<b>8</b>	<b>CHECK INTERMITTENT INCIDENT</b>
Refer to "TROUBLE DIAGNOSIS FOR INTERMITTENT INCIDENT", EC-115.	
<p>▶ <b>INSPECTION END</b></p>	

	<table border="1"> <tr> <td colspan="2" style="text-align: center;">■ ACTIVE TEST ■</td> </tr> <tr> <td>VC/V BYPASS/V</td> <td style="text-align: right;">OFF</td> </tr> <tr> <td colspan="2" style="text-align: center;">===== MONITOR =====</td> </tr> <tr> <td>CMPS-RPM(REF)</td> <td style="text-align: right;">0rpm</td> </tr> <tr> <td>FR O2 MNTR-B1</td> <td style="text-align: right;">RICH</td> </tr> <tr> <td>A/F ALPHA-B1</td> <td style="text-align: right;">100%</td> </tr> <tr> <td>THRTL POS SEN</td> <td style="text-align: right;">0.52V</td> </tr> <tr> <td>ON</td> <td>ON/OFF</td> <td>OFF</td> </tr> </table>	■ ACTIVE TEST ■		VC/V BYPASS/V	OFF	===== MONITOR =====		CMPS-RPM(REF)	0rpm	FR O2 MNTR-B1	RICH	A/F ALPHA-B1	100%	THRTL POS SEN	0.52V	ON	ON/OFF	OFF
■ ACTIVE TEST ■																		
VC/V BYPASS/V	OFF																	
===== MONITOR =====																		
CMPS-RPM(REF)	0rpm																	
FR O2 MNTR-B1	RICH																	
A/F ALPHA-B1	100%																	
THRTL POS SEN	0.52V																	
ON	ON/OFF	OFF																

SEF395V

SEF351Q

## Component Inspection VACUUM CUT VALVE BYPASS VALVE

NEEC0509

NEEC0509S01

Check air passage continuity.

Ⓜ With CONSULT

Perform "VC/V BYPASS/V" in "ACTIVE TEST" mode.

Condition VC/V BYPASS/V	Air passage continuity between A and B
ON	Yes
OFF	No

⊗ Without CONSULT

Condition	Air passage continuity between A and B
12V direct current supply between terminals	Yes
No supply	No

If NG or operation takes more than 1 second, replace vacuum cut valve bypass valve.

GI  
MA  
EM  
LC  
EC  
FE  
CL  
MT  
AT  
TF  
PD  
FA  
RA  
BR  
ST  
RS  
BT  
HA  
EL  
IDX

# DTC P1491 VACUUM CUT VALVE BYPASS VALVE

## Description

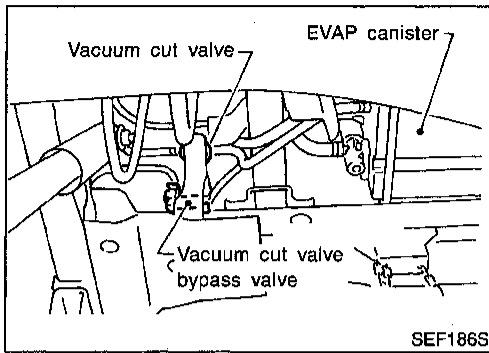

## Description

### COMPONENT DESCRIPTION

The vacuum cut valve and vacuum cut valve bypass valve are installed in parallel on the EVAP purge line between the fuel tank and the EVAP canister.

The vacuum cut valve prevents the intake manifold vacuum from being applied to the fuel tank.

The vacuum cut valve bypass valve is a solenoid type valve and generally remains closed. It opens only for on board diagnosis.

The vacuum cut valve bypass valve responds to signals from the ECM. When the ECM sends an ON (ground) signal, the valve is opened. The vacuum cut valve is then bypassed to apply intake manifold vacuum to the fuel tank.

### EVAPORATIVE EMISSION SYSTEM DIAGRAM

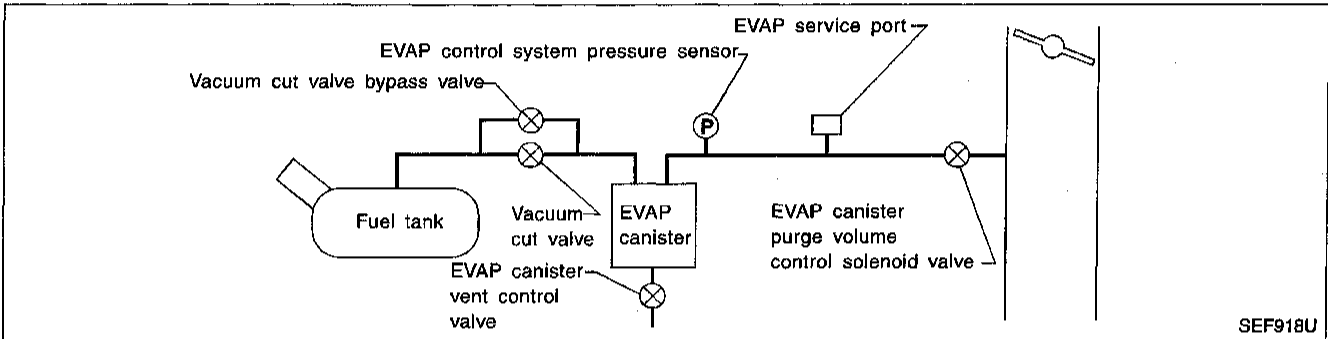

## CONSULT Reference Value in Data Monitor Mode

Specification data are reference values.

MONITOR ITEM	CONDITION	SPECIFICATION
VCV/ BYPASS/V	• Ignition switch: ON	OFF

## ECM Terminals and Reference Value

Specification data are reference values and are measured between each terminal and 32 (ECM ground).

TERMI- NAL NO.	WIRE COLOR	ITEM	CONDITION	DATA (DC Voltage)
120	P/B	Vacuum cut valve bypass valve	[Ignition switch "ON"]	BATTERY VOLTAGE (11 - 14V)

# DTC P1491 VACUUM CUT VALVE BYPASS VALVE

On Board Diagnosis Logic

## On Board Diagnosis Logic

NEEC0513

DTC No.	Malfunction is detected when ...	Check Items (Possible Cause)
P1491 0311	Vacuum cut valve bypass valve does not operate properly.	<ul style="list-style-type: none"> <li>• Vacuum cut valve bypass valve</li> <li>• Vacuum cut valve</li> <li>• Bypass hoses for clogging</li> <li>• EVAP control system pressure sensor and circuit</li> <li>• EVAP canister vent control valve</li> <li>• Hose between fuel tank and vacuum cut valve clogged</li> <li>• Hose between vacuum cut valve and EVAP canister clogged</li> <li>• EVAP canister</li> <li>• EVAP purge port of fuel tank for clogging</li> </ul>

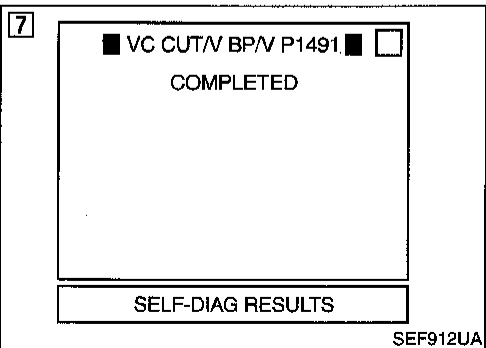
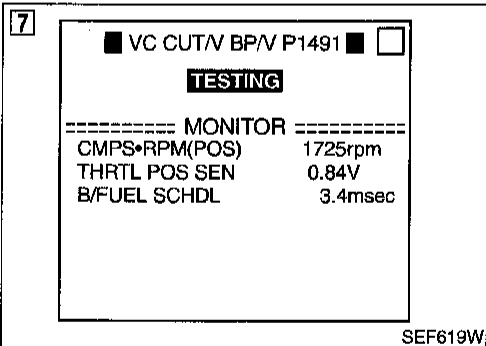
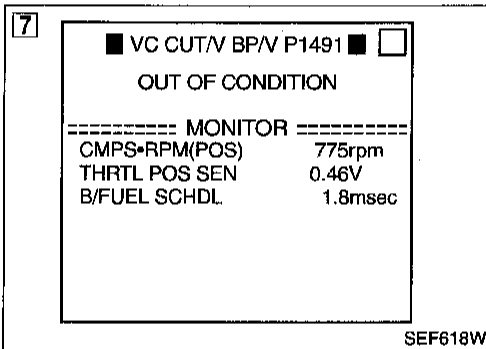

### DTC Confirmation Procedure

NEEC0514

#### CAUTION:

Always drive vehicle at a safe speed.

#### NOTE:

If "DTC Confirmation Procedure" has been previously conducted, always turn ignition switch "OFF" and wait at least 5 seconds before conducting the next test.

#### TESTING CONDITION:

Always perform test at a temperature of 5 to 30°C (41 to 86°F).

#### With CONSULT

- 1) Turn ignition switch "ON".
- 2) Start engine and warm it up to normal operating temperature.
- 3) Turn ignition switch "OFF" and wait at least 5 seconds.
- 4) Start engine and let it idle for at least 70 seconds.
- 5) Select "VC CUT/V BP/V P1491" of "EVAPORATIVE SYSTEM" in "DTC WORK SUPPORT" mode with CONSULT.
- 6) Touch "START".
- 7) When the following conditions are met, "TESTING" will be displayed on the CONSULT screen. Maintain the conditions continuously until "TESTING" changes to "COMPLETED". (It will take at least 30 seconds.)

CMPS-RPM (POS)	500 - 3,000 rpm
Selector lever	Suitable position
Vehicle speed	36 - 120 km/h (22 - 75 MPH)
B/FUEL SCHDL	Less than 5 msec

If "TESTING" is not displayed after 5 minutes, retry from step 3.

- 8) Make sure that "OK" is displayed after touching "SELF-DIAG RESULTS". If "NG" is displayed, refer to "Diagnostic Procedure", EC-436.

# DTC P1491 VACUUM CUT VALVE BYPASS VALVE

## Overall Function Check

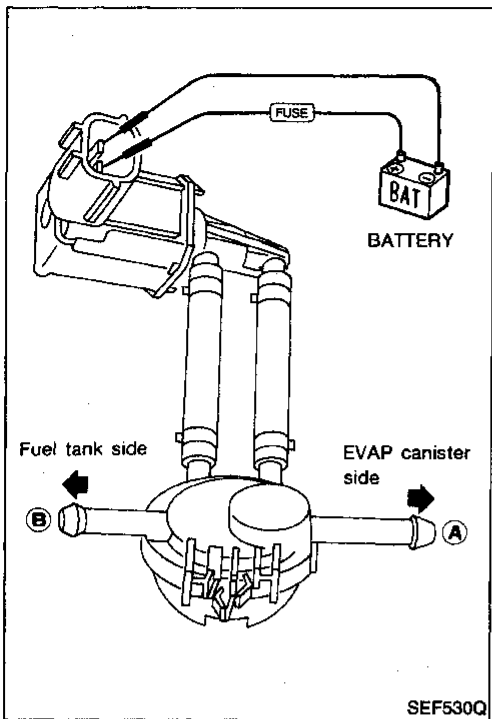

## Overall Function Check

NEEC0515

Use this procedure to check the overall function of vacuum cut valve bypass valve. During this check, the 1st trip DTC might not be confirmed.

### ⊗ Without CONSULT

- 1) Remove vacuum cut valve and vacuum cut valve bypass valve as an assembly.
- 2) Apply vacuum to port **A** and check that there is no suction from port **B**.
- 3) Apply vacuum to port **B** and check that there is suction from port **A**.
- 4) Blow air in port **B** and check that there is a resistance to flow out of port **A**.
- 5) Supply battery voltage to the terminal.
- 6) Blow air in port **A** and check that air flows freely out of port **B**.
- 7) Blow air in port **B** and check that air flows freely out of port **A**.
- 8) If NG, go to "Diagnostic Procedure", EC-436.



# DTC P1491 VACUUM CUT VALVE BYPASS VALVE

Wiring Diagram

## Wiring Diagram

NEEC0516

### EC-BYPS/V-01

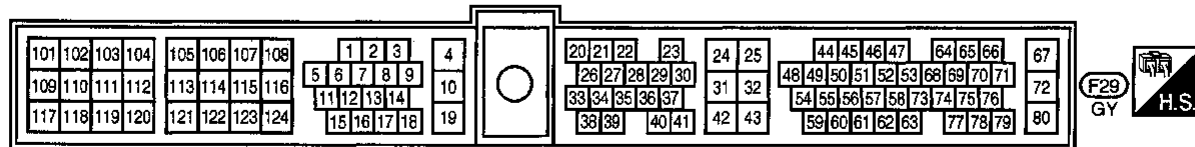
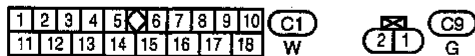
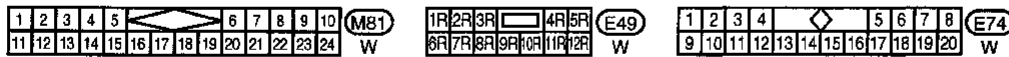
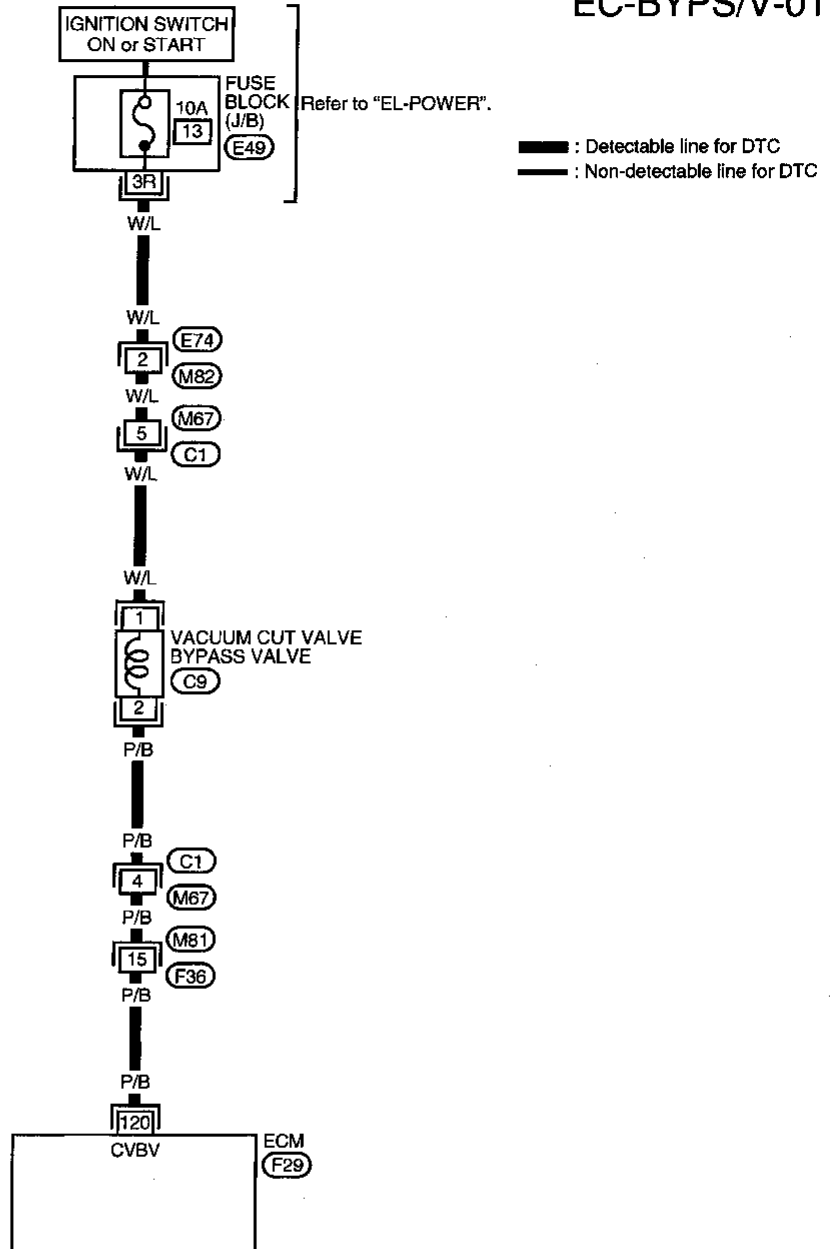

AEC749A

EC-435

# DTC P1491 VACUUM CUT VALVE BYPASS VALVE

Diagnostic Procedure

## Diagnostic Procedure

NEEC0517

<b>1</b>	<b>INSPECTION START</b>
Do you have CONSULT?	
Yes or No	
Yes	▶ GO TO 2.
No	▶ GO TO 3.

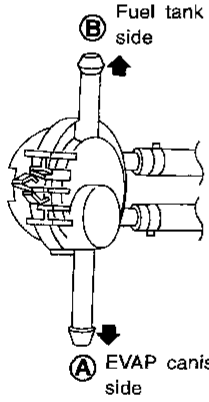
<b>2</b>	<b>CHECK VACUUM CUT VALVE BYPASS VALVE OPERATION</b>																				
<p><b>Ⓟ With CONSULT</b></p> <ol style="list-style-type: none"> <li>Turn ignition switch "OFF".</li> <li>Remove vacuum cut valve and vacuum cut valve bypass valve as an assembly.</li> <li>Apply vacuum to port A and check that there is no suction from port B.</li> <li>Apply vacuum to port B and check that there is suction from port A.</li> <li>Blow air in port B and check that there is a resistance to flow out of port A.</li> <li>Turn ignition switch "ON".</li> <li>Select "VC/V BYPASS/V" in "ACTIVE TEST" mode with CONSULT and touch "ON".</li> <li>Blow air in port A and check that air flows freely out of port B.</li> <li>Blow air in port B and check that air flows freely out of port A.</li> </ol>																					
																					
<table border="1" style="width: 100%;"> <tr> <td colspan="2" style="text-align: center;">■ ACTIVE TEST ■</td> </tr> <tr> <td>VC/V BYPASS/V</td> <td style="text-align: right;">ON</td> </tr> <tr> <td colspan="2" style="text-align: center;">===== MONITOR =====</td> </tr> <tr> <td>CMPS•RPM(REF)</td> <td style="text-align: right;">0rpm</td> </tr> <tr> <td>FR O2 MNTR-B2</td> <td style="text-align: right;">LEAN</td> </tr> <tr> <td>FR O2 MNTR-B1</td> <td style="text-align: right;">LEAN</td> </tr> <tr> <td>A/F ALPHA-B2</td> <td style="text-align: right;">100%</td> </tr> <tr> <td>A/F ALPHA-B1</td> <td style="text-align: right;">100%</td> </tr> <tr> <td>THRTL POS SEN</td> <td style="text-align: right;">0.46V</td> </tr> <tr> <td colspan="2" style="text-align: center;"> <input type="button" value="ON"/> <input type="button" value="ON/OFF"/> <input type="button" value="OFF"/> </td> </tr> </table>		■ ACTIVE TEST ■		VC/V BYPASS/V	ON	===== MONITOR =====		CMPS•RPM(REF)	0rpm	FR O2 MNTR-B2	LEAN	FR O2 MNTR-B1	LEAN	A/F ALPHA-B2	100%	A/F ALPHA-B1	100%	THRTL POS SEN	0.46V	<input type="button" value="ON"/> <input type="button" value="ON/OFF"/> <input type="button" value="OFF"/>	
■ ACTIVE TEST ■																					
VC/V BYPASS/V	ON																				
===== MONITOR =====																					
CMPS•RPM(REF)	0rpm																				
FR O2 MNTR-B2	LEAN																				
FR O2 MNTR-B1	LEAN																				
A/F ALPHA-B2	100%																				
A/F ALPHA-B1	100%																				
THRTL POS SEN	0.46V																				
<input type="button" value="ON"/> <input type="button" value="ON/OFF"/> <input type="button" value="OFF"/>																					
SEF913U																					
OK or NG																					
OK	▶ GO TO 4.																				
NG	▶ GO TO 5.																				

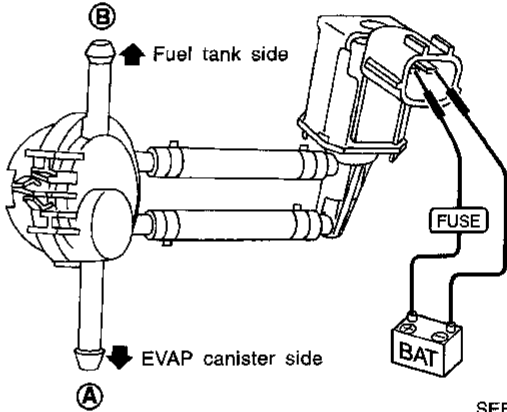
<b>3</b>	<b>CHECK VACUUM CUT VALVE BYPASS VALVE OPERATION</b>
<p><b>ⓧ Without CONSULT</b></p> <ol style="list-style-type: none"> <li>Turn ignition switch "OFF".</li> <li>Remove vacuum cut valve and vacuum cut valve bypass valve as an assembly.</li> <li>Apply vacuum to port A and check that there is no suction from port B.</li> <li>Apply vacuum to port B and check that there is suction from port A.</li> <li>Blow air in port B and check that there is a resistance to flow out of port A.</li> <li>Disconnect vacuum cut valve bypass valve harness connector.</li> <li>Supply battery voltage to the terminal.</li> <li>Blow air in port A and check that air flows freely out of port B.</li> <li>Blow air in port B and check that air flows freely out of port A.</li> </ol>	
	
SEF914U	
OK or NG	
OK	▶ GO TO 4.
NG	▶ GO TO 5.

<b>4</b>	<b>CHECK EVAP PURGE LINE</b>
<ol style="list-style-type: none"> <li>Check EVAP purge line between EVAP canister and fuel tank for clogging or disconnection.</li> <li>Check EVAP purge port of fuel tank for clogging.</li> <li>Check EVAP canister. Refer to EC-25.</li> </ol>	
OK or NG	
OK	▶ GO TO 8.
NG (Step 1)	▶ Repair it.
NG (Step 2)	▶ Clean EVAP purge port.
NG (Step 3)	▶ Replace EVAP canister.

<b>5</b>	<b>CHECK BYPASS HOSE</b>
Check bypass hoses for clogging.	
OK or NG	
OK	▶ GO TO 6.
NG	▶ Repair or replace hoses.

# DTC P1491 VACUUM CUT VALVE BYPASS VALVE

Diagnostic Procedure (Cont'd)

<b>6</b>	<b>CHECK VACUUM CUT VALVE BYPASS VALVE</b>
Refer to "Component Inspection", EC-438.	
<b>OK or NG</b>	
OK	▶ GO TO 7.
NG	▶ Replace vacuum cut valve bypass valve.

<b>7</b>	<b>CHECK VACUUM CUT VALVE</b>
Refer to "Component Inspection", EC-438.	
<b>OK or NG</b>	
OK	▶ GO TO 8.
NG	▶ Replace vacuum cut valve.

<b>8</b>	<b>CHECK EVAP CONTROL SYSTEM PRESSURE SENSOR HOSE</b>
1. Turn ignition switch "OFF". 2. Check disconnection or improper connection of hose connected to EVAP control system pressure sensor.	
<b>OK or NG</b>	
OK	▶ GO TO 9.
NG	▶ Repair it

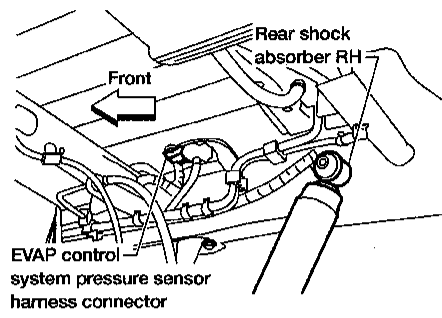
<b>9</b>	<b>CHECK CONNECTOR</b>
1. Disconnect EVAP control system pressure sensor harness connector.	
	
2. Check connectors for water. <b>Water should not exist.</b>	
<b>OK or NG</b>	
OK	▶ GO TO 10.
NG	▶ Replace EVAP control system pressure sensor.

<b>10</b>	<b>CHECK EVAP CONTROL SYSTEM PRESSURE SENSOR FUNCTION</b>
Refer to "DTC Confirmation Procedure" for DTC P0450, EC-323.	
<b>OK or NG</b>	
OK	▶ GO TO 11.
NG	▶ Replace EVAP control system pressure sensor.

<b>11</b>	<b>CHECK EVAP CANISTER VENT CONTROL VALVE</b>
Refer to "Component Inspection", EC-425.	
<b>OK or NG</b>	
OK	▶ GO TO 12.
NG	▶ Replace EVAP canister vent control valve.

<b>12</b>	<b>CHECK INTERMITTENT INCIDENT</b>
Refer to "TROUBLE DIAGNOSIS FOR INTERMITTENT INCIDENT", EC-115.	
▶ <b>INSPECTION END</b>	

GI  
MA  
EM  
LC  
EC  
FE  
CL  
MT  
AT  
TF  
PD  
FA  
RA  
BR  
ST  
RS  
BT  
HA  
EL  
IDX

# DTC P1491 VACUUM CUT VALVE BYPASS VALVE

## Component Inspection

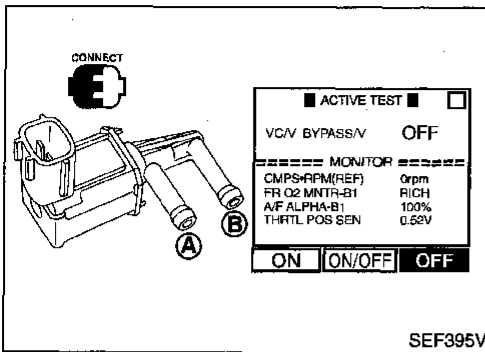

## Component Inspection VACUUM CUT VALVE BYPASS VALVE

NEEC0518

NEEC0518S01

Check air passage continuity.

### With CONSULT

Perform "VC/V BYPASS/V" in "ACTIVE TEST" mode.

Condition VC/V BYPASS/V	Air passage continuity between A and B
ON	Yes
OFF	No

### Without CONSULT

Condition	Air passage continuity between A and B
12V direct current supply between terminals	Yes
No supply	No

If NG or operation takes more than 1 second, replace vacuum cut valve bypass valve.

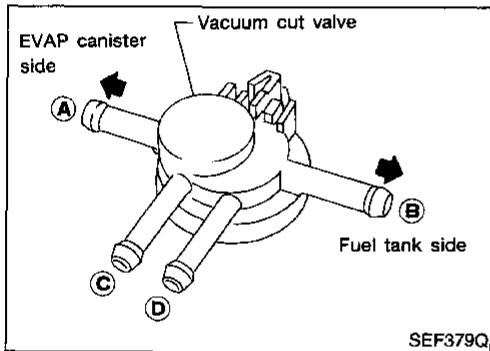
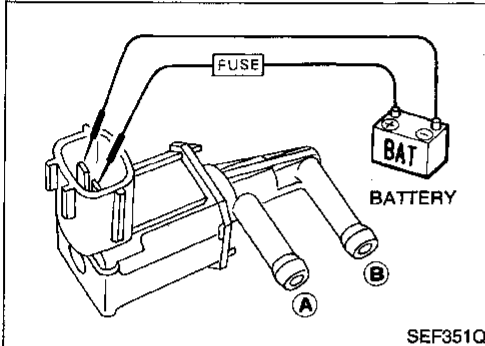

## VACUUM CUT VALVE

NEEC0518S02

Check vacuum cut valve as follows:

1. Plug port C and D with fingers.
2. Apply vacuum to port A and check that there is no suction from port B.
3. Apply vacuum to port B and check that there is suction from port A.
4. Blow air in port B and check that there is a resistance to flow out of port A.
5. Open port C and D.
6. Blow air in port A check that air flows freely out of port C.
7. Blow air in port B check that air flows freely out of port D.

# DTC P1605 A/T DIAGNOSIS COMMUNICATION LINE

Component Description

## Component Description

The malfunction information related to A/T (Automatic Transmission) is transferred through the line (circuit) from TCM (Transmission control module) to ECM. Therefore, be sure to erase the malfunction information such as DTC not only in TCM (Transmission control module) but also ECM after the A/T related repair.

## ECM Terminals and Reference Value

Specification data are reference values and are measured between each terminal and 32 (ECM ground).

TERMI- NAL NO.	WIRE COLOR	ITEM	CONDITION	DATA (DC Voltage)
7	G/B	A/T check signal	[Ignition switch "ON"] [Engine is running]	0 - 3.0V

## On Board Diagnosis Logic

DTC No.	Malfunction is detected when ...	Check Items (Possible Cause)
P1605 0804	<ul style="list-style-type: none"> <li>An incorrect signal from TCM (Transmission control module) is sent to ECM.</li> </ul>	<ul style="list-style-type: none"> <li>Harness or connectors [The communication line circuit between ECM and TCM (Transmission control module) is open or shorted.]</li> <li>Dead (Weak) battery</li> <li>TCM (Transmission control module)</li> </ul>

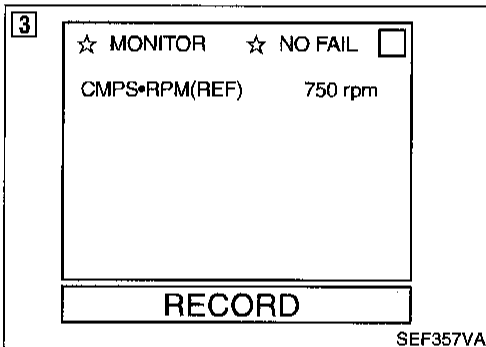

## DTC Confirmation Procedure

### NOTE:

If "DTC Confirmation Procedure" has been previously conducted, always turn ignition switch "OFF" and wait at least 5 seconds before conducting the next test.

### TESTING CONDITION:

Before performing the following procedure, confirm that battery voltage is more than 10.5V at idle.

#### ④ With CONSULT

- 1) Turn ignition switch "ON".
- 2) Select "DATA MONITOR" mode with CONSULT.
- 3) Start engine and wait at least 40 seconds.
- 4) If 1st trip DTC is detected, go to "Diagnostic Procedure", EC-441.

#### ④ With GST

- 1) Turn ignition switch "ON".
- 2) Start engine and wait at least 40 seconds.
- 3) Select "MODE 7" with GST.
- 4) If 1st trip DTC is detected, go to "Diagnostic Procedure", EC-441.

#### ④ No Tools

- 1) Turn ignition switch "ON".
- 2) Start engine and wait at least 40 seconds.
- 3) Turn ignition switch "OFF", wait at least 5 seconds and then turn "ON".
- 4) Perform "Diagnostic Test Mode II" (Self-diagnostic results) with ECM.
- 5) If 1st trip DTC is detected, go to "Diagnostic Procedure", EC-441.

# DTC P1605 A/T DIAGNOSIS COMMUNICATION LINE

Wiring Diagram

## Wiring Diagram

NEEC0342

### EC-ATDIAG-01

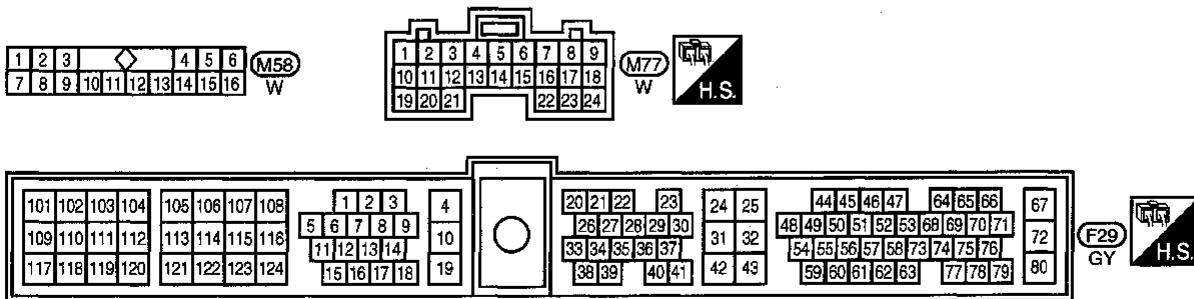
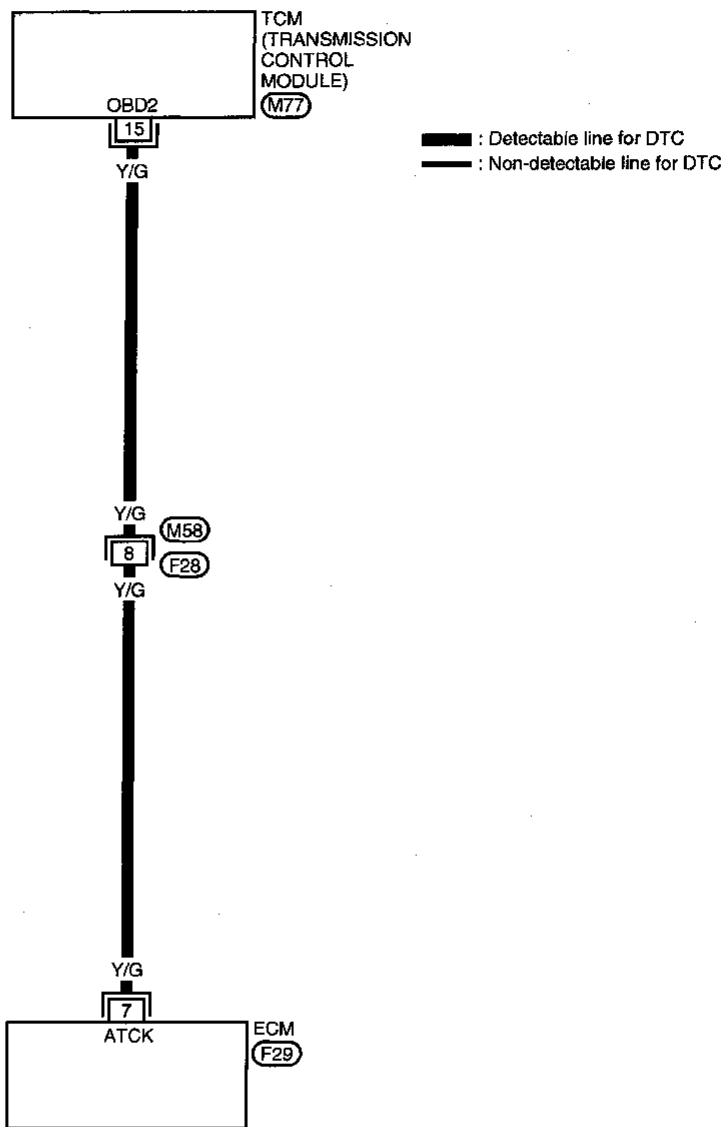

AEC764A

## Diagnostic Procedure

NEEC0343

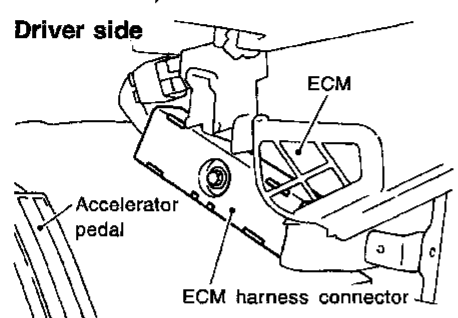
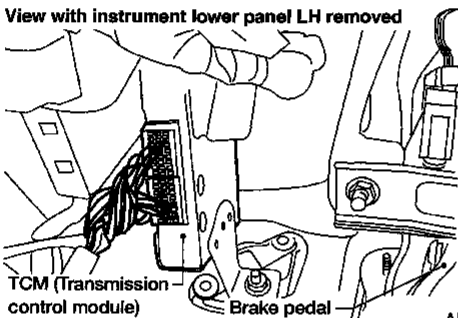
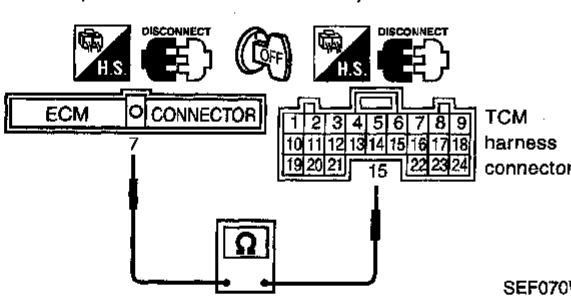
<b>1</b>	<b>CHECK INPUT SIGNAL CIRCUIT</b>						
<p>1. Turn ignition switch "OFF".</p> <p>2. Disconnect ECM harness connector and TCM (Transmission Control Module) harness connector.</p>							
<p><b>Driver side</b></p>  <p>SEF324V</p>							
<p><b>View with instrument lower panel LH removed</b></p>  <p>AEC655A</p>							
<p>3. Check harness continuity between ECM terminal 7 and TCM (Transmission Control Module) terminal 15.</p>							
 <p>SEF070W</p>							
<p><b>Continuity should exist.</b></p> <p>4. Also check harness for short to ground and short to power.</p> <p style="text-align: center;"><b>OK or NG</b></p> <table border="1" style="width: 100%; border-collapse: collapse;"> <tr> <td style="width: 15%;">OK</td> <td style="width: 10%; text-align: center;">▶</td> <td>GO TO 3.</td> </tr> <tr> <td>NG</td> <td style="text-align: center;">▶</td> <td>GO TO 2.</td> </tr> </table>		OK	▶	GO TO 3.	NG	▶	GO TO 2.
OK	▶	GO TO 3.					
NG	▶	GO TO 2.					

<b>3</b>	<b>CHECK INTERMITTENT INCIDENT</b>
<p>Refer to "TROUBLE DIAGNOSIS FOR INTERMITTENT INCIDENT", EC-115.</p>	
<p>▶ <b>INSPECTION END</b></p>	

<b>2</b>	<b>DETECT MALFUNCTIONING PART</b>
<p>Check the following.</p> <ul style="list-style-type: none"> <li>• Harness connectors M58, F28</li> <li>• Harness for open or short between ECM and TCM (Transmission Control Module)</li> </ul>	
<p>▶ Repair open circuit or short to ground or short to power in harness or connectors.</p>	

GI  
MA  
EM  
LC  
EC  
FE  
CL  
MT  
AT  
TF  
PD  
FA  
RA  
BR  
ST  
RS  
BT  
HA  
EL  
IDX

# DTC P1706 PARK/NEUTRAL POSITION (PNP) SWITCH

## Component Description

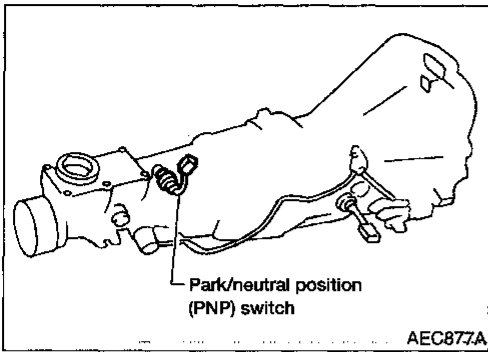

## Component Description

When the gear position is "P" (A/T models only) or "N", park/neutral position (PNP) switch is "ON".

ECM detects the position because the continuity of the line (the "ON" signal) exists.

For A/T models, the park/neutral position (PNP) switch assembly also includes a transmission range switch to detect selector lever position.

## CONSULT Reference Value in Data Monitor Mode

Specification data are reference values.

MONITOR ITEM	CONDITION	SPECIFICATION
P/N POSI SW	• Ignition switch: ON	Shift lever: "P" or "N" ON
		Except above OFF

## ECM Terminals and Reference Value

Specification data are reference values and are measured between each terminal and 32 (ECM ground).

TERMI- NAL NO.	WIRE COLOR	ITEM	CONDITION	DATA (DC Voltage)
22	L/B	Park/neutral position (PNP) switch	[Ignition switch "ON"] • Gear position is "N" or "P" (A/T models) • Gear position is neutral (M/T models)	Approximately 0V
			[Ignition switch "ON"] • Except the above gear position	Approximately 5V

## On Board Diagnosis Logic

DTC No.	Malfunction is detected when ...	Check Items (Possible Cause)
P1706 1003	• The signal of the park/neutral position (PNP) switch is not changed in the process of engine starting and driving.	• Harness or connectors [The park/neutral position (PNP) switch circuit is open or shorted.] • Park/neutral position (PNP) switch

## DTC Confirmation Procedure

### CAUTION:

Always drive vehicle at a safe speed.

### NOTE:

If "DTC Confirmation Procedure" has been previously conducted, always turn ignition switch "OFF" and wait at least 5 seconds before conducting the next test.



# DTC P1706 PARK/NEUTRAL POSITION (PNP) SWITCH

DTC Confirmation Procedure (Cont'd)

**2**

■ PARK/NEUT POSI SW CKT ■

SHIFT  
OUT OF N/P -RANGE  
THEN  
TOUCH START

**NEXT**    **START**

SEF962NA

**5**

☆ MONITOR    ☆ NO FAIL   

CMPS•RPM(POS)	2150rpm
COOLAN TEMP/S	85°C
VHCL SPEED SE	80km/h
P/N POSI SW	OFF
B/FUEL SCHDL	4.4ms

**RECORD**

AEC917A

**2**

☆ MONITOR    ☆ NO FAIL   

P/N POSI SW            ON

**RECORD**

SEF963NA

**5**

☆ MONITOR    ☆ NO FAIL   

CMPS•RPM(REF)	812rpm
COOLAN TEMP/S	85°C
VHCL SPEED SE	0km/h
P/N POSI SW	ON
B/FUEL SCHDL	0.9msec

**RECORD**

AEC918A

**With CONSULT**

- 1) Turn ignition switch "ON".
- 2) Perform "PARK/NEUT POSI SW CKT" in "FUNCTION TEST" mode with CONSULT.  
If NG, go to "Diagnostic Procedure", EC-446.  
If OK, go to following step.
- 3) Select "DATA MONITOR" mode with CONSULT.
- 4) Start engine and warm it up to normal operating temperature.
- 5) Maintain the following conditions for at least 60 consecutive seconds.

CMPS-RPM (POS)	1,600 - 2,650 rpm
COOLAN TEMP/S	More than 70°C (158°F)
B/FUEL SCHDL	1.7 - 6.5 msec
VHCL SPEED SE	70 - 100 km/h (43 - 75 MPH)
Selector lever	Suitable position

- 6) If 1st trip DTC is detected, go to "Diagnostic Procedure", EC-446.

**With CONSULT**

- 1) Turn ignition switch "ON".
- 2) Select "P/N POSI SW" in "DATA MONITOR" mode with CONSULT. Then check the "P/N POSI SW" signal under the following conditions.

Position (Selector lever)	Known good signal
"N" and "P" position	ON
Except the above position	OFF

If NG, go to "Diagnostic Procedure", EC-446.  
If OK, go to following step.

- 3) Select "DATA MONITOR" mode with CONSULT.
- 4) Start engine and warm it up to normal operating temperature.
- 5) Maintain the following conditions for at least 60 consecutive seconds.

CMPS-RPM (POS)	1,600 - 2,650 rpm
COOLAN TEMP/S	More than 70°C (158°F)
B/FUEL SCHDL	1.7 - 6.5 msec
VHCL SPEED SE	70 - 100 km/h (43 - 75 MPH)
Selector lever	Suitable position

- 6) If 1st trip DTC is detected, go to "Diagnostic Procedure", EC-446.

GI  
MA  
EM  
LC  
EC  
FE  
CL  
MT  
AT  
TF  
PD  
FA  
RA  
BR  
ST  
RS  
BT  
HA  
EL  
IDX

# DTC P1706 PARK/NEUTRAL POSITION (PNP) SWITCH

## Overall Function Check

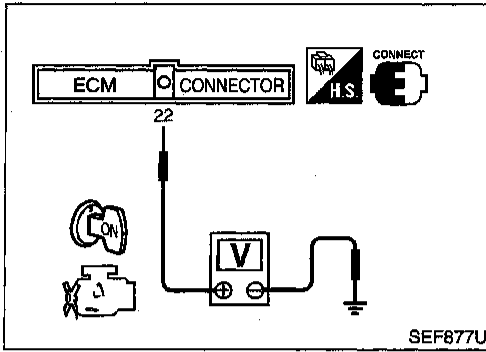

## Overall Function Check

NEEC0519

Use this procedure to check the overall function of the park/neutral position (PNP) switch circuit. During this check, a 1st trip DTC might not be confirmed.

### ⊗ Without CONSULT

- 1) Turn ignition switch "ON".
- 2) Check voltage between ECM terminal 22 and body ground under the following conditions.

Condition (Gear position)	Voltage (V) (Known good data)
"P" and "N" position	Approx. 0
Except the above position	Approx. 5

- 3) If NG, go to "Diagnostic Procedure", EC-446.

# DTC P1706 PARK/NEUTRAL POSITION (PNP) SWITCH

Wiring Diagram

## Wiring Diagram

NEEC0277

### EC-PNP/SW-01

- : With theft warning system
- : Without theft warning system
- : With A/T
- : With M/T

- : Detectable line for DTC
- : Non-detectable line for DTC

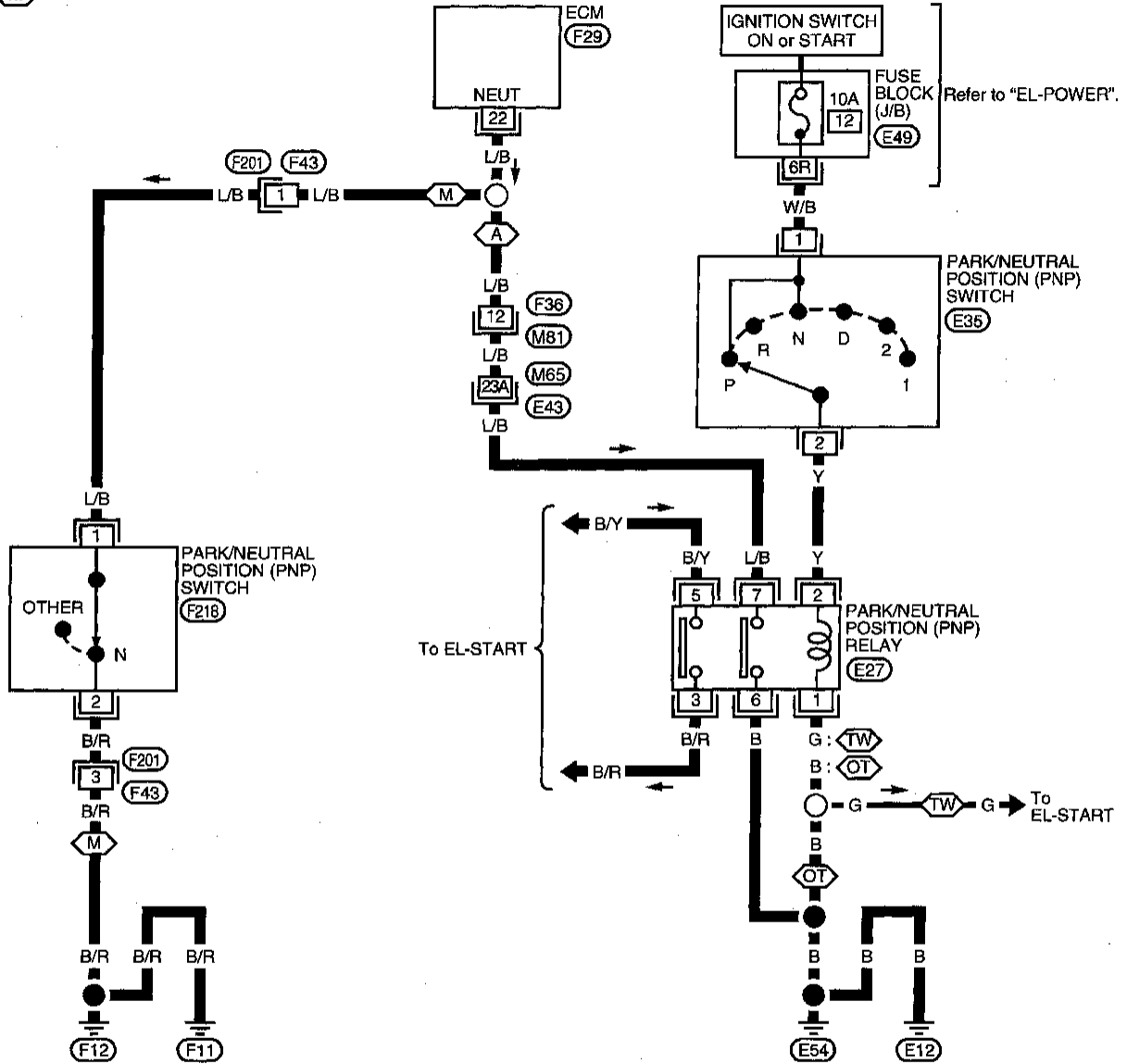

Refer to last page (Foldout page).  
M65, E43

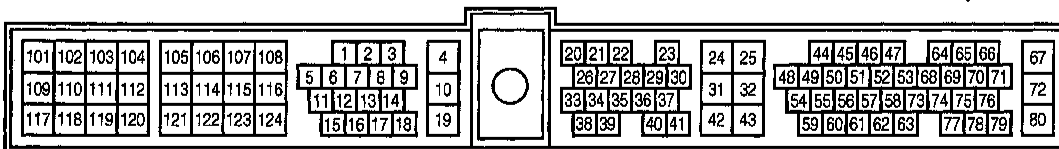

AEC765A

# DTC P1706 PARK/NEUTRAL POSITION (PNP) SWITCH

Diagnostic Procedure

## Diagnostic Procedure FOR M/T MODELS

NEEC0278

NEEC0278S01

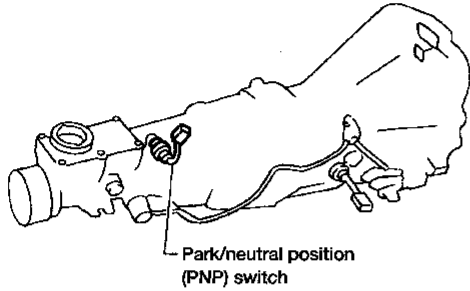
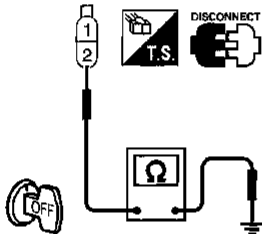
<b>1</b>	<b>CHECK GROUND CIRCUIT</b>
<p>1. Turn ignition switch "OFF".</p> <p>2. Disconnect park/neutral position (PNP) switch harness connector.</p>	
 <p style="text-align: right;">AEC877A</p>	
<p>3. Check harness continuity between terminal 2 and engine ground.</p>	
 <p style="text-align: right;">SEF766U</p>	
<p>Continuity should exist.</p> <p>4. Also check harness for short to ground and short to power.</p> <p style="text-align: center;"><b>OK or NG</b></p>	
OK	▶ GO TO 3.
NG	▶ GO TO 2.

<b>2</b>	<b>DETECT MALFUNCTIONING PART</b>
<p>Check the following.</p> <ul style="list-style-type: none"> <li>• Harness connectors F201, F43</li> <li>• Harness for open or short between park/neutral position (PNP) switch and engine ground</li> </ul>	
▶	Repair open circuit or short to ground or short to power in harness or connectors.

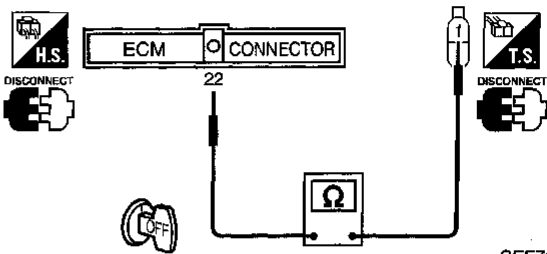
<b>3</b>	<b>CHECK INPUT SIGNAL CIRCUIT</b>
<p>1. Disconnect ECM harness connector.</p> <p>2. Check harness continuity between ECM terminal 22 and terminal 1.</p>	
 <p style="text-align: right;">SEF767U</p>	
<p>Continuity should exist.</p> <p>3. Also check harness for short to ground and short to power.</p> <p style="text-align: center;"><b>OK or NG</b></p>	
OK	▶ GO TO 5.
NG	▶ GO TO 4.

<b>4</b>	<b>DETECT MALFUNCTIONING PART</b>
<p>Check the following.</p> <ul style="list-style-type: none"> <li>• Harness connectors F43, F201</li> <li>• Harness for open or short between ECM and park/neutral position (PNP) switch</li> </ul>	
▶	Repair open circuit or short to ground or short to power in harness or connectors.

<b>5</b>	<b>CHECK PARK/NEUTRAL POSITION (PNP) SWITCH</b>
<p>Refer to "Position Switch Check", "ON-VEHICLE SERVICE" in MT section.</p> <p style="text-align: center;"><b>OK or NG</b></p>	
OK	▶ GO TO 6.
NG	▶ Replace park/neutral position (PNP) switch.

<b>6</b>	<b>CHECK INTERMITTENT INCIDENT</b>
<p>Refer to "TROUBLE DIAGNOSIS FOR INTERMITTENT INCIDENT", EC-115.</p>	
▶	INSPECTION END

# DTC P1706 PARK/NEUTRAL POSITION (PNP) SWITCH

Diagnostic Procedure (Cont'd)

## FOR A/T MODELS

-NEEC0278S02

### 1 CHECK POWER SUPPLY-I

- Turn ignition switch "OFF".
- Disconnect park/neutral position (PNP) relay.

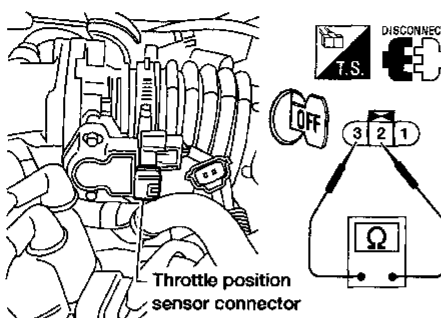

Throttle position sensor connector

AEC665A

- Turn ignition switch "ON".
- Shift selector lever to "P" or "N" position.
- Check voltage between terminal 2 and ground with CONSULT or tester.

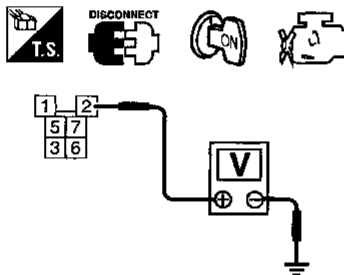

Voltage: Battery voltage

OK or NG

OK	▶	GO TO 6.
NG	▶	GO TO 2.

### 2 CHECK POWER SUPPLY-II

- Turn ignition switch "OFF".
- Disconnect park/neutral position (PNP) switch harness connector.

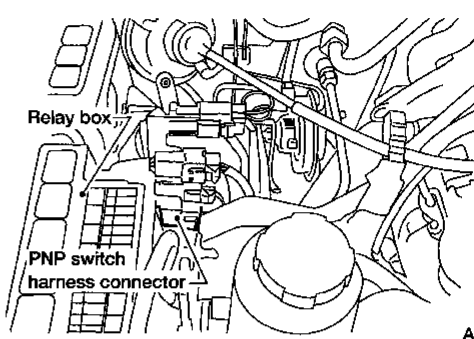

Relay box

PNP switch harness connector

AEC662A

- Check harness continuity between park/neutral position (PNP) switch terminal 2 and park/neutral position (PNP) relay terminal 2.

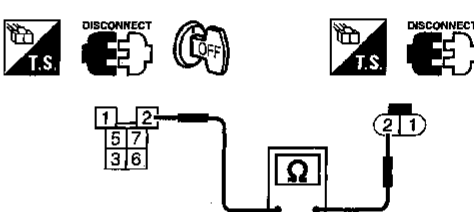

Continuity should exist.

- Also check harness for short to ground and short to power.

OK or NG

OK	▶	GO TO 3.
NG	▶	Repair open circuit or short to ground or short to power in harness or connectors.

### 3 CHECK POWER SUPPLY-III

- Turn ignition switch "OFF".
- Check voltage between park/neutral position (PNP) switch terminal 1 and ground with CONSULT or tester.

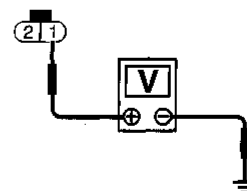

Voltage: Battery voltage

OK or NG

OK	▶	GO TO 5.
NG	▶	GO TO 4.

G1  
MA  
EM  
LC  
EC  
FE  
CL  
MT  
AT  
TF  
PD  
FA  
RA  
BR  
ST  
RS  
BT  
HA  
EL  
IDX

# DTC P1706 PARK/NEUTRAL POSITION (PNP) SWITCH

## Diagnostic Procedure (Cont'd)

<b>4</b>	<b>DETECT MALFUNCTIONING PART</b>
Check the following. <ul style="list-style-type: none"> <li>• Fuse block (J/B) connector E49</li> <li>• 10A fuse</li> <li>• Harness for open or short between park/neutral position (PNP) switch and fuse</li> </ul>	
▶	Repair open circuit or short to ground or short to power in harness or connectors.

<b>5</b>	<b>CHECK PARK/NEUTRAL POSITION (PNP) SWITCH</b>
Refer to "Component Inspection", "TROUBLE DIAGNOSES" in AT section.	
<b>OK or NG</b>	
OK	▶ GO TO 11.
NG	▶ Replace park/neutral position (PNP) switch.

<b>6</b>	<b>CHECK GROUND CIRCUIT</b>
1. Turn ignition switch "OFF". 2. Check harness continuity between relay terminals 1, 6 and body ground.	
<b>Continuity should exist.</b> 3. Also check harness for short to ground and short to power.	
<b>OK or NG</b>	
OK	▶ GO TO 8.
NG (With theft warning system)	▶ GO TO 7.
NG (Without theft warning system)	▶ Repair open circuit or short to ground or short to power in harness or connectors.

<b>7</b>	<b>DETECT MALFUNCTIONING PART</b>
Check the circuit between park/neutral position (PNP) relay and body ground. Refer to "STARTING SYSTEM" in SC section.	
<b>OK or NG</b>	
OK	▶ GO TO 11.
NG	▶ Repair or replace.

<b>8</b>	<b>CHECK INPUT SIGNAL CIRCUIT</b>
1. Disconnect ECM harness connector. 2. Check harness continuity between ECM terminal 22 and relay terminal 7.	
<b>Continuity should exist.</b> 3. Also check harness for short to ground and short to power.	
<b>OK or NG</b>	
OK	▶ GO TO 10.
NG	▶ GO TO 9.

<b>9</b>	<b>DETECT MALFUNCTIONING PART</b>
Check the following. <ul style="list-style-type: none"> <li>• Harness connectors F36, M81</li> <li>• Harness connectors M65, E43</li> <li>• Harness for open or short between ECM and park/neutral position (PNP) relay</li> </ul>	
▶	Repair open circuit or short to ground or short to power in harness or connectors.

<b>10</b>	<b>CHECK PARK/NEUTRAL POSITION (PNP) RELAY</b>
1. Apply 12V direct current between park/neutral position (PNP) relay terminals 1 and 2. 2. Check continuity between park/neutral position (PNP) relay terminals 3 and 5, 6 and 7.	
<b>12V (1 and 2) applied: Continuity should exist.</b> <b>No voltage applied: Continuity should not exist.</b>	
<b>OK or NG</b>	
OK	▶ GO TO 11.
NG	▶ Replace park/neutral position (PNP) relay.

# DTC P1706 PARK/NEUTRAL POSITION (PNP) SWITCH

Diagnostic Procedure (Cont'd)

11	<b>CHECK INTERMITTENT INCIDENT</b>
Refer to "TROUBLE DIGNOSIS FOR INTERMITTENT INCIDENT", EC-115.	
▶	<b>INSPECTION END</b>

GI

MA

EM

LC

**EC**

FE

CL

MT

AT

TF

PD

FA

RA

BR

ST

RS

BT

HA

EL

IDX

# TROUBLE DIAGNOSIS FOR OVERHEAT (COOLING SYSTEM)

System Description

## System Description

NEEC0523

NEEC0523S01

### COOLING FAN CONTROL

Sensor	Input Signal to ECM	ECM function	Actuator
Vehicle speed sensor	Vehicle speed	Cooling fan control	Cooling fan relay(s)
Engine coolant temperature sensor	Engine coolant temperature		
Ignition switch	Start signal		
Camshaft position sensor	Engine speed		

The ECM controls the cooling fan corresponding to the signals sent from the vehicle speed and engine coolant temperature. The control system has 2-step control [ON/OFF].

### OPERATION

NEEC0523S02

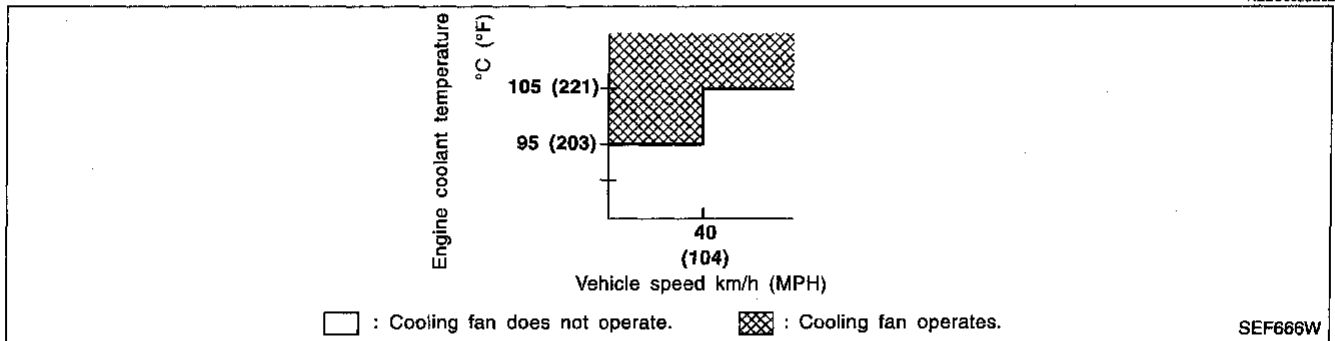

### CONSULT Reference Value in Data Monitor Mode

NEEC0524

Specification data are reference values.

MONITOR ITEM	CONDITION	SPECIFICATION
COOLING FAN	<ul style="list-style-type: none"> <li>Engine: Idling, after warming up</li> <li>Air conditioner switch: OFF</li> </ul>	OFF
	Engine coolant temperature is 95°C (203°F) or more.	ON

### ECM Terminals and Reference Value

NEEC0525

Specification data are reference values and are measured between each terminal and 32 (ECM ground).

TERMI-NAL NO.	WIRE COLOR	ITEM	CONDITION	DATA (DC Voltage)
36	LG/R	Cooling fan relay	<b>[Engine is running]</b> <ul style="list-style-type: none"> <li>Cooling fan is not operating</li> </ul>	BATTERY VOLTAGE (11 - 14V)
			<b>[Engine is running]</b> <ul style="list-style-type: none"> <li>Cooling fan is operating</li> </ul>	0 - 0.6V

### On Board Diagnosis Logic

NEEC0526

If the cooling fan or another component in the cooling system malfunctions, engine coolant temperature will rise. When the engine coolant temperature reaches an abnormally high temperature condition, a malfunction is indicated.



# TROUBLE DIAGNOSIS FOR OVERHEAT (COOLING SYSTEM)

On Board Diagnosis Logic (Cont'd)

Diagnostic Trouble Code No.	Malfunction is detected when ...	Check Items (Possible Cause)
OVER HEAT 0208	<ul style="list-style-type: none"> <li>Engine coolant temperature reaches an abnormally high temperature.</li> </ul>	<ul style="list-style-type: none"> <li>Harness or connectors (The cooling fan circuit is open or shorted.)</li> <li>Cooling fan</li> <li>Radiator hose</li> <li>Radiator</li> <li>Radiator cap</li> <li>Water pump</li> <li>Thermostat</li> </ul> <p>For more information, refer to "MAIN 12 CAUSES OF OVERHEATING", EC-457.</p>

## CAUTION:

When a malfunction is indicated, be sure to replace the coolant following the procedure in the MA section ("Changing Engine Coolant", "ENGINE MAINTENANCE"). Also, replace the engine oil.

- 1) Fill radiator with coolant up to specified level with a filling speed of 2 liters per minute like pouring coolant by kettle. Be sure to use coolant with the proper mixture ratio. Refer to MA section ("Anti-freeze Coolant Mixture Ratio", "RECOMMENDED FLUIDS AND LUBRICANTS").
- 2) After refilling coolant, run engine to ensure that no water-flow noise is emitted.

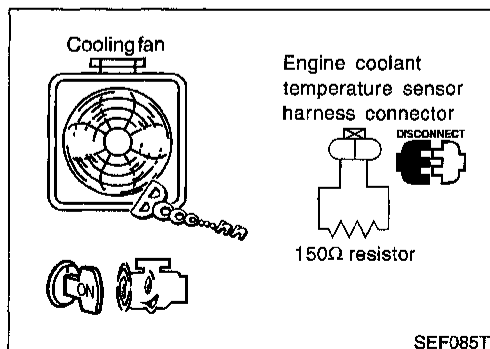
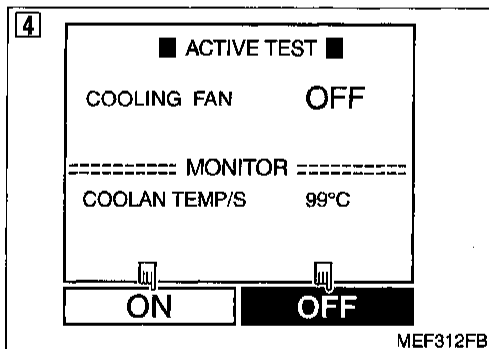
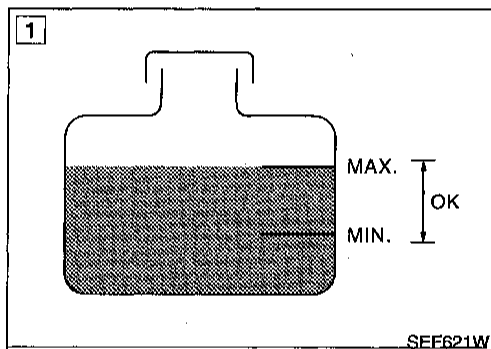

## Overall Function Check

Use this procedure to check the overall function of the cooling fan. During this check, a DTC might not be confirmed.

### WARNING:

Never remove the radiator cap when the engine is hot. Serious burns could be caused by high pressure fluid escaping from the radiator.

Wrap a thick cloth around cap. Carefully remove the cap by turning it a quarter turn to allow built-up pressure to escape. Then turn the cap all the way off.

### ⓑ With CONSULT

- 1) Check the coolant level in the reservoir tank and radiator. **Allow engine to cool before checking coolant level.** If the coolant level in the reservoir tank and/or radiator is below the proper range, skip the following steps and go to "Diagnostic Procedure", EC-454.
- 2) Confirm whether customer filled the coolant or not. If customer filled the coolant, skip the following steps and go to "Diagnostic Procedure", EC-454.
- 3) Turn ignition switch "ON".
- 4) Perform "COOLING FAN" in "ACTIVE TEST" mode with CONSULT.
- 5) Make sure that cooling fan operates.
- 6) If NG, go to "Diagnostic Procedure", EC-454.

### ⓐ Without CONSULT

- 1) Check the coolant level in the reservoir tank and radiator. **Allow engine to cool before checking coolant level.** If the coolant level in the reservoir tank and/or radiator is below the proper range, skip the following steps and go to "Diagnostic Procedure", EC-454.
- 2) Confirm whether customer filled the coolant or not. If customer filled the coolant, skip the following steps and go to "Diagnostic Procedure", EC-454.
- 3) Turn ignition switch "OFF".

EC-451

## TROUBLE DIAGNOSIS FOR OVERHEAT (COOLING SYSTEM)

### Overall Function Check (Cont'd)

---

- 4) Disconnect engine coolant temperature sensor harness connector.
- 5) Connect 150 $\Omega$  resistor to engine coolant temperature sensor harness connector.
- 6) Start engine and make sure that cooling fan operates.  
**Be careful not to overheat engine.**
- 7) If NG, go to "Diagnostic Procedure", EC-454.

# TROUBLE DIAGNOSIS FOR OVERHEAT (COOLING SYSTEM)

Wiring Diagram

## Wiring Diagram

NEEC0528

EC-COOL/F-01

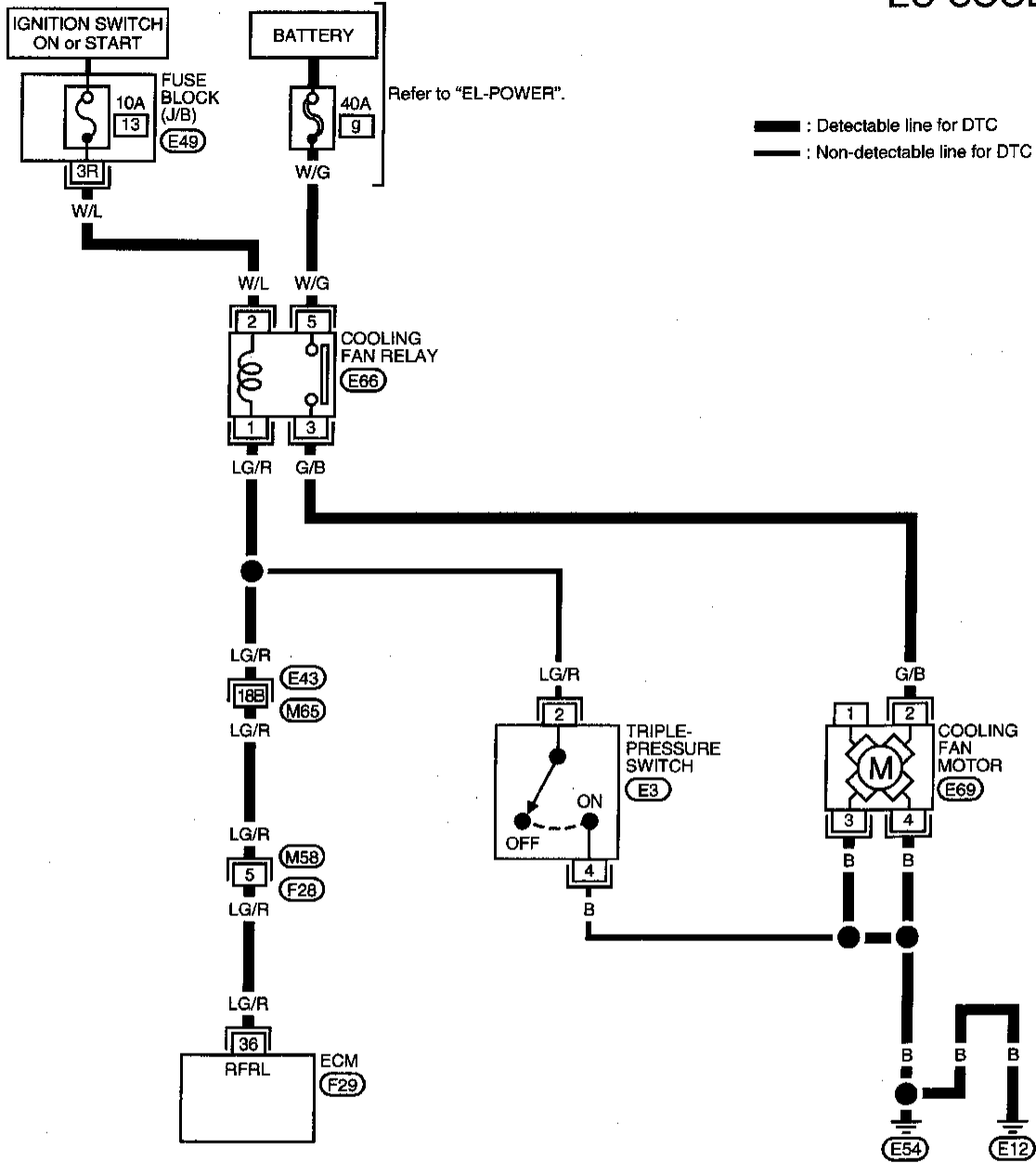

Refer to last page (Foldout page).

(M65), (E43)

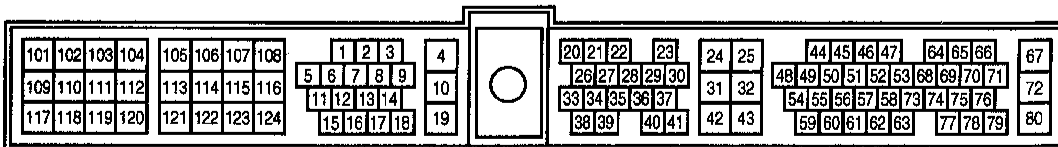
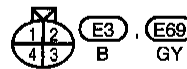
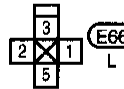
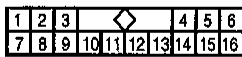

AEC766A

EC-453

# TROUBLE DIAGNOSIS FOR OVERHEAT (COOLING SYSTEM)

Diagnostic Procedure

## Diagnostic Procedure

NEEC0529

<b>1</b>	<b>INSPECTION START</b>
Do you have CONSULT?	
Yes or No	
Yes	▶ GO TO 2.
No	▶ GO TO 3.

<b>2</b>	<b>CHECK COOLING FAN OPERATION</b>
<p><b>Ⓜ With CONSULT</b></p> <p>1. Turn ignition switch "ON".</p> <p>2. Perform "COOLING FAN CIRCUIT" in "FUNCTION TEST" mode with CONSULT.</p>	
<div style="border: 1px solid black; padding: 5px; width: fit-content; margin: 0 auto;"> <p>■ COOLING FAN CIRCUIT ■</p> <p>DOES</p> <p>COOLING FAN</p> <p>ROTATE AND STOP</p> <p>EVERY 3 SECONDS ?</p> <p style="text-align: center;"> <input type="button" value="NEXT"/> <input type="button" value="NO"/> <input type="button" value="YES"/> </p> </div>	
MEF311F	
<p><b>Ⓜ With CONSULT</b></p> <p>1. Turn ignition switch "ON".</p> <p>2. Perform "COOLING FAN" in "ACTIVE TEST" mode with CONSULT (Low speed).</p>	

<div style="border: 1px solid black; padding: 5px; width: fit-content; margin: 0 auto;"> <p>■ ACTIVE TEST ■</p> <p>COOLING FAN    OFF</p> <p>== == MONITOR == ==</p> <p>COOLAN TEMP/S    99°C</p> <p style="text-align: center;"> <input type="button" value="ON"/> <input type="button" value="OFF"/> </p> </div>	
<p>Does cooling fan rotate?</p> <p>Yes or No</p>	
Yes	▶ GO TO 4.
No	▶ GO TO 9.

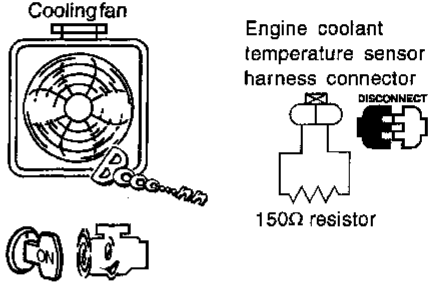
<b>3</b>	<b>CHECK COOLING FAN OPERATION</b>
<p><b>ⓧ Without CONSULT</b></p> <p>1. Turn ignition switch "OFF".</p> <p>2. Disconnect engine coolant temperature sensor harness connector.</p> <p>3. Connect 150Ω resistor to engine coolant temperature sensor harness connector.</p> <p>4. Start engine and make sure that cooling fan operates.</p>	
	
SEF085T	
OK or NG	
OK	▶ GO TO 4.
NG	▶ GO TO 9.

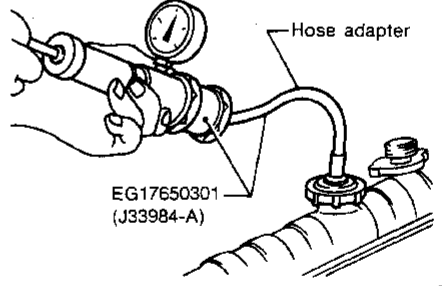
<b>4</b>	<b>CHECK COOLING SYSTEM FOR LEAK</b>
<p>Apply pressure to the cooling system with a tester, and check if the pressure drops.</p> <p><b>CAUTION:</b></p> <p>Higher than the specified pressure may cause radiator damage.</p> <p>Testing pressure: 157 kPa (1.6 kg/cm<sup>2</sup>, 23 psi)</p>	
	
SLC754A	
Pressure should not drop.	
OK or NG	
OK	▶ GO TO 5.
NG	▶ <b>Check the following for leak</b>
<ul style="list-style-type: none"> <li>• Hose</li> <li>• Radiator</li> <li>• Water pump</li> </ul> <p>Refer to LC section ("Water Pump").</p>	

# TROUBLE DIAGNOSIS FOR OVERHEAT (COOLING SYSTEM)

Diagnostic Procedure (Cont'd)

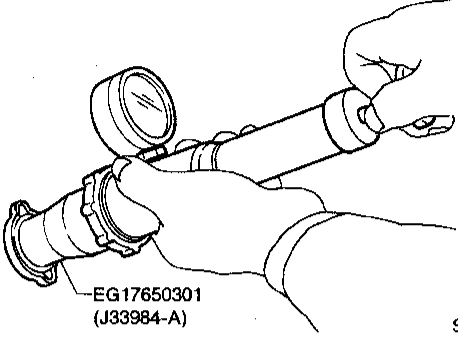
<b>5</b>	<b>CHECK RADIATOR CAP</b>
Apply pressure to cap with a tester and check radiator cap relief pressure.	
	
<b>Radiator cap relief pressure:</b> 59 - 98 kPa (0.6 - 1.0 kg/cm <sup>2</sup> , 9 - 14 psi)	
<b>OK or NG</b>	
OK	▶ GO TO 6.
NG	▶ Replace radiator cap.

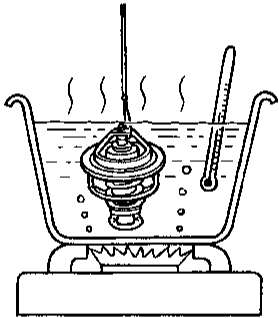
<b>6</b>	<b>CHECK THERMOSTAT</b>
1. Check valve seating condition at normal room temperatures. <b>It should seat tightly.</b>	
2. Check valve opening temperature and valve lift.	
	
<b>Valve opening temperature:</b> 76.5°C (170°F) [standard]	
<b>Valve lift:</b> More than 8 mm/90°C (0.31 in/194°F)	
3. Check if valve is closed at 5°C (9°F) below valve opening temperature. For details, refer to LC section ("Thermostat").	
<b>OK or NG</b>	
OK	▶ GO TO 7.
NG	▶ Replace thermostat

<b>7</b>	<b>CHECK ENGINE COOLANT TEMPERATURE SENSOR</b>
Refer to "COMPONENT INSPECTION", EC-149.	
<b>OK or NG</b>	
OK	▶ GO TO 8.
NG	▶ Replace engine coolant temperature sensor.

<b>8</b>	<b>CHECK MAIN 12 CAUSES</b>
If the cause cannot be isolated, go to "MAIN 12 CAUSES OF OVERHEATING", EC-457.	
▶ <b>INSPECTION END</b>	

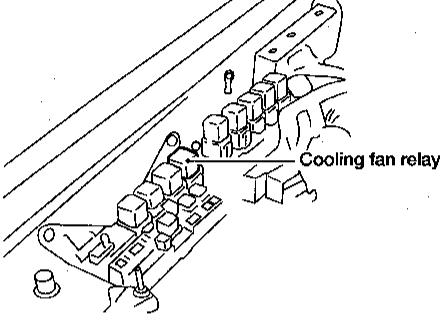
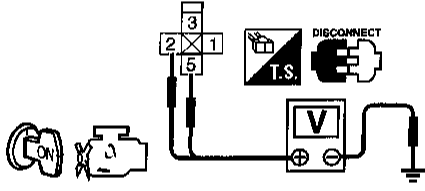
<b>9</b>	<b>CHECK POWER SUPPLY</b>
1. Turn ignition switch "OFF". 2. Disconnect cooling fan relay.	
	
3. Turn ignition switch "ON". 4. Check voltage between terminals 2, 5 and ground with CONSULT or tester.	
	
<b>Voltage: Battery voltage</b>	
<b>OK or NG</b>	
OK	▶ GO TO 11.
NG	▶ GO TO 10.

<b>10</b>	<b>DETECT MALFUNCTIONING PART</b>
Check the following.	
<ul style="list-style-type: none"> <li>• Fuse block (J/B) connector E49</li> <li>• 10A fuse</li> <li>• 40A fusible link</li> <li>• Harness for open or short between cooling fan relay and fuse</li> <li>• Harness for open or short between cooling fan relay and battery</li> </ul>	
▶ Repair open circuit or short to ground or short to power in harness or connectors.	

GI  
 MA  
 EM  
 LC  
 EC  
 FE  
 CL  
 MT  
 AT  
 TF  
 PD  
 FA  
 RA  
 BR  
 ST  
 RS  
 BT  
 HA  
 EL  
 IDX

# TROUBLE DIAGNOSIS FOR OVERHEAT (COOLING SYSTEM)

Diagnostic Procedure (Cont'd)

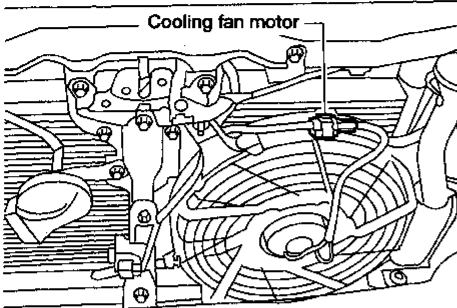
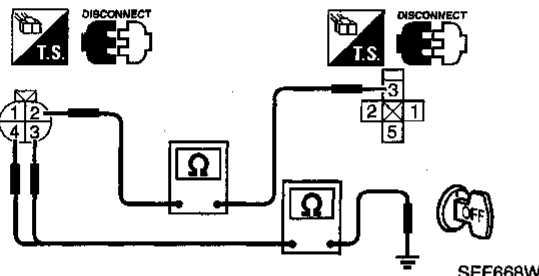
<b>11</b>	<b>CHECK GROUND CIRCUIT</b>
<p>1. Turn ignition switch "OFF".                  2. Disconnect cooling fan motor harness connector.</p>	
 <p style="text-align: center;">Cooling fan motor</p> <p style="text-align: right;">AEC931A</p>	
<p>3. Check harness continuity between relay terminal 3 and motor terminal 2, motor terminals 3, 4 and body ground.</p>	
 <p style="text-align: right;">SEF668W</p>	
<p><b>Continuity should exist.</b></p>	
<p>4. Also check harness for short to ground and short to power.</p>	
<p><b>OK or NG</b></p>	
OK	▶ GO TO 12.
NG	▶ Repair open circuit or short to ground or short to power in harness or connectors.

<b>13</b>	<b>DETECT MALFUNCTIONING PART</b>
<p>Check the following.</p> <ul style="list-style-type: none"> <li>• Harness connectors E43, M65</li> <li>• Harness connectors M58, F28</li> <li>• Harness for open or short between cooling fan relay and ECM</li> </ul>	
▶	
<p>Repair open circuit or short to ground or short to power in harness or connectors.</p>	

<b>14</b>	<b>CHECK COOLING FAN RELAY</b>
<p>Refer to "Component Inspection", EC-458.</p>	
<p><b>OK or NG</b></p>	
OK	▶ GO TO 15.
NG	▶ Replace cooling fan relay.

<b>15</b>	<b>CHECK COOLING FAN MOTOR</b>
<p>Refer to "Component Inspection", EC-458.</p>	
<p><b>OK or NG</b></p>	
OK	▶ GO TO 16.
NG	▶ Replace cooling fan motor.

<b>16</b>	<b>CHECK INTERMITTENT INCIDENT</b>
<p>Perform "TROUBLE DIAGNOSIS FOR INTERMITTENT INCIDENT", EC-115.</p>	
▶	
<p><b>INSPECTION END</b></p>	

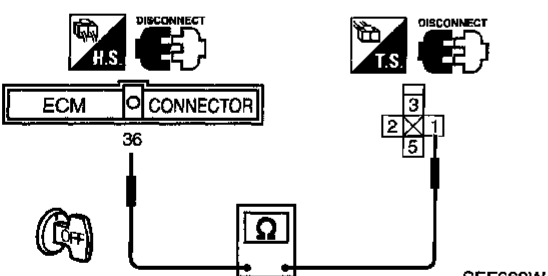
<b>12</b>	<b>CHECK OUTPUT SIGNAL CIRCUIT</b>
<p>1. Disconnect ECM harness connector.                  2. Check harness continuity between ECM terminal 36 and relay terminal 1.</p>	
 <p style="text-align: right;">SEF669W</p>	
<p><b>Continuity should exist.</b></p>	
<p>3. Also check harness for short to ground and short to power.</p>	
<p><b>OK or NG</b></p>	
OK	▶ GO TO 14.
NG	▶ GO TO 13.

# TROUBLE DIAGNOSIS FOR OVERHEAT (COOLING SYSTEM)

Main 12 Causes of Overheating

## Main 12 Causes of Overheating

NEEC0530

Engine	Step	Inspection item	Equipment	Standard	Reference page
OFF	1	<ul style="list-style-type: none"> <li>Blocked radiator</li> <li>Blocked condenser</li> <li>Blocked radiator grille</li> <li>Blocked bumper</li> </ul>	<ul style="list-style-type: none"> <li>Visual</li> </ul>	No blocking	—
	2	<ul style="list-style-type: none"> <li>Coolant mixture</li> </ul>	<ul style="list-style-type: none"> <li>Coolant tester</li> </ul>	50 - 50% coolant mixture	See "RECOMMENDED FLUIDS AND LUBRICANTS" in MA section.
	3	<ul style="list-style-type: none"> <li>Coolant level</li> </ul>	<ul style="list-style-type: none"> <li>Visual</li> </ul>	Coolant up to MAX level in reservoir tank and radiator filler neck	See "Changing Engine Coolant", "ENGINE MAINTENANCE" in MA section.
	4	<ul style="list-style-type: none"> <li>Radiator cap</li> </ul>	<ul style="list-style-type: none"> <li>Pressure tester</li> </ul>	59 - 98 kPa (0.6 - 1.0 kg/cm <sup>2</sup> , 9 - 14 psi) (Limit)	See "System Check", "ENGINE COOLING SYSTEM" in LC section.
ON*2	5	<ul style="list-style-type: none"> <li>Coolant leaks</li> </ul>	<ul style="list-style-type: none"> <li>Visual</li> </ul>	No leaks	See "System Check", "ENGINE COOLING SYSTEM" in LC section.
ON*2	6	<ul style="list-style-type: none"> <li>Thermostat</li> </ul>	<ul style="list-style-type: none"> <li>Touch the upper and lower radiator hoses</li> </ul>	Both hoses should be hot	See "Thermostat" and "Radiator", "ENGINE COOLING SYSTEM" in LC section.
ON*1	7	<ul style="list-style-type: none"> <li>Cooling fan</li> </ul>	<ul style="list-style-type: none"> <li>CONSULT</li> </ul>	Operating	See "TROUBLE DIAGNOSIS FOR OVERHEAT" (EC-450).
OFF	8	<ul style="list-style-type: none"> <li>Combustion gas leak</li> </ul>	<ul style="list-style-type: none"> <li>Color checker chemical tester 4 Gas analyzer</li> </ul>	Negative	—
ON*3	9	<ul style="list-style-type: none"> <li>Coolant temperature gauge</li> </ul>	<ul style="list-style-type: none"> <li>Visual</li> </ul>	Gauge less than 3/4 when driving	—
		<ul style="list-style-type: none"> <li>Coolant overflow to reservoir tank</li> </ul>	<ul style="list-style-type: none"> <li>Visual</li> </ul>	No overflow during driving and idling	See "Changing Engine Coolant", "ENGINE MAINTENANCE" in MA section.
OFF*4	10	<ul style="list-style-type: none"> <li>Coolant return from reservoir tank to radiator</li> </ul>	<ul style="list-style-type: none"> <li>Visual</li> </ul>	Should be initial level in reservoir tank	See "ENGINE MAINTENANCE" in MA section.
OFF	11	<ul style="list-style-type: none"> <li>Cylinder head</li> </ul>	<ul style="list-style-type: none"> <li>Straight gauge feeler gauge</li> </ul>	0.1 mm (0.004 in) Maximum distortion (warping)	See "Inspection", "CYLINDER HEAD" in EM section.
	12	<ul style="list-style-type: none"> <li>Cylinder block and pistons</li> </ul>	<ul style="list-style-type: none"> <li>Visual</li> </ul>	No scuffing on cylinder walls or piston	See "Inspection", "CYLINDER BLOCK" in EM section.

\*1: Turn the ignition switch ON.

\*2: Engine running at 3,000 rpm for 10 minutes.

\*3: Drive at 90 km/h (55 MPH) for 30 minutes and then let idle for 10 minutes.

\*4: After 60 minutes of cool down time.

For more information, refer to "OVERHEATING CAUSE ANALYSIS" in LC section.

# TROUBLE DIAGNOSIS FOR OVERHEAT (COOLING SYSTEM)

## Component Inspection

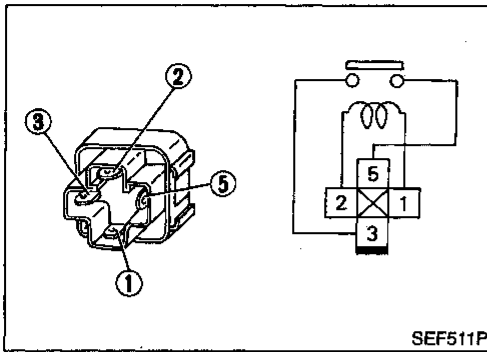

### Component Inspection

#### COOLING FAN RELAY

NEEC0531

NEEC0531S01

Check continuity between terminals 3 and 5.

Conditions	Continuity
12V direct current supply between terminals 1 and 2	Yes
No current supply	No

If NG, replace relay.

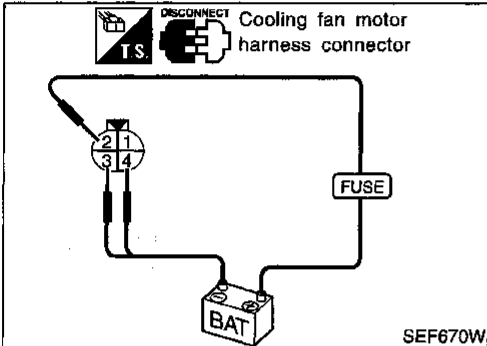

### COOLING FAN MOTOR

NEEC0531S02

1. Disconnect cooling fan motor harness connector.
2. Supply cooling fan motor terminals with battery voltage and check operation.

	Terminals	
	(+)	(-)
Cooling fan motor	2	3, 4

**Cooling fan motor should operate.**

If NG, replace cooling fan motor.



# INJECTOR

Component Description

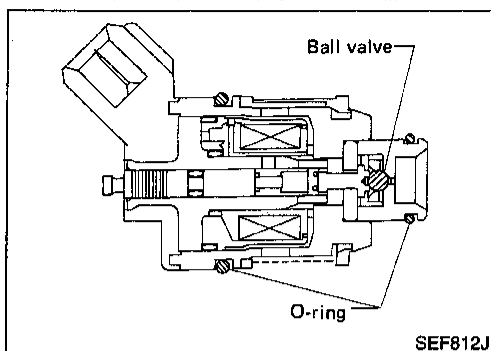

## Component Description

NEEC0345

The fuel injector is a small, precise solenoid valve. When the ECM supplies a ground to the injector circuit, the coil in the injector is energized. The energized coil pulls the needle valve back and allows fuel to flow through the injector into the intake manifold. The amount of fuel injected depends upon the injection pulse duration. Pulse duration is the length of time the injector remains open. The ECM controls the injection pulse duration based on engine fuel needs.

## CONSULT Reference Value in Data Monitor Mode

NEEC0522

Specification data are reference values.

MONITOR ITEM	CONDITION	SPECIFICATION
INJ PULSE-B2 INJ PULSE-B1	• Engine: After warming up • Air conditioner switch: "OFF" • Shift lever: "N" • No-load Idle	2.4 - 3.7 msec
	2,000 rpm	1.9 - 3.3 msec
B/FUEL SCHDL	ditto Idle	1.0 - 1.6 msec
	2,000 rpm	0.7 - 1.4 msec

## ECM Terminals and Reference Value

NEEC0346

Specification data are reference values and are measured between each terminal and 32 (ECM ground).

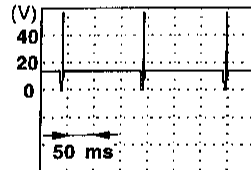
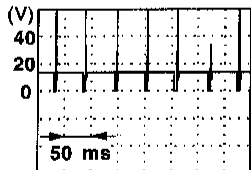
TERMI- NAL NO.	WIRE COLOR	ITEM	CONDITION	DATA (DC Voltage)
102 104 106 109 111 113	W/B W/R W/G W/L W/PU W	Injector No. 1 Injector No. 3 Injector No. 5 Injector No. 2 Injector No. 4 Injector No. 6	[Engine is running] • Warm-up condition • Idle speed	BATTERY VOLTAGE (11 - 14V) 
			[Engine is running] • Warm-up condition • Engine speed is 2,000 rpm	BATTERY VOLTAGE (11 - 14V) 

# INJECTOR

Wiring Diagram

## Wiring Diagram

NEEC0344

### EC-INJECT-01

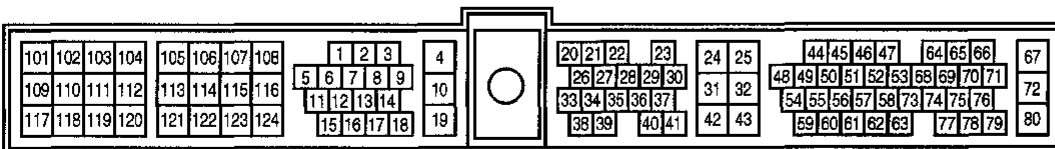
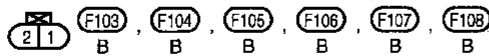
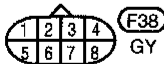
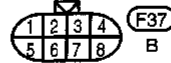
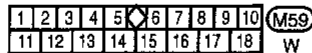
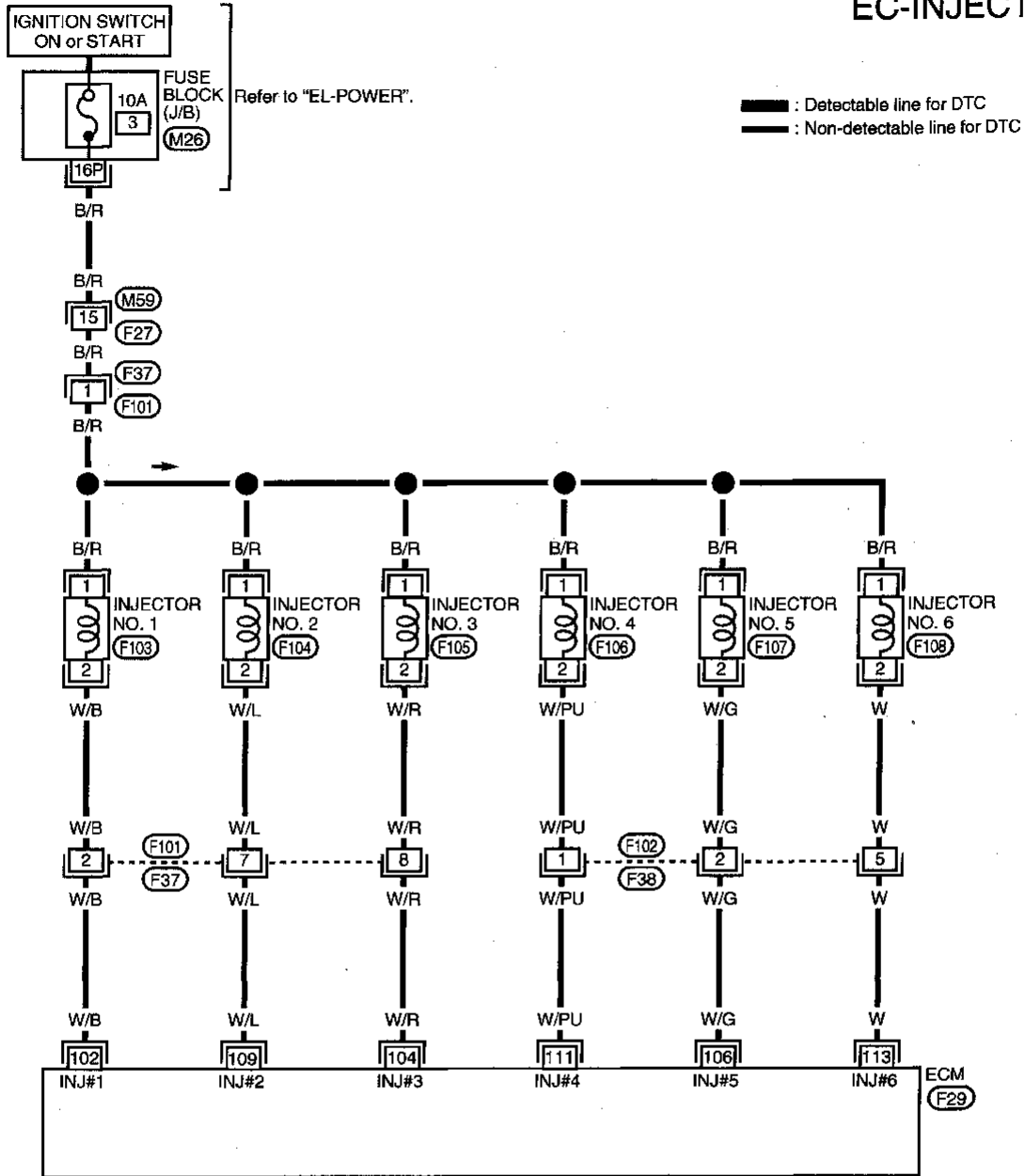

AEC767A

EC-460

## Diagnostic Procedure

NEEC0347

<b>1</b>	<b>INSPECTION START</b>
Turn ignition switch to "START". <b>Is any cylinder ignited?</b>	
Yes or No	
Yes	▶ GO TO 2.
No	▶ GO TO 3.

<b>2</b>	<b>CHECK OVERALL FUNCTION</b>										
<p><b>Ⓜ With CONSULT</b></p> <ol style="list-style-type: none"> <li>Start engine.</li> <li>Perform "POWER BALANCE" in "ACTIVE TEST" mode with CONSULT.</li> </ol>											
<div style="border: 1px solid black; padding: 5px; width: fit-content; margin: 0 auto;"> <p style="text-align: center;">■ ACTIVE TEST ■</p> <p style="text-align: center;">*** POWER BALANCE ***</p> <p style="text-align: center;">----- MONITOR -----</p> <table style="width: 100%; border-collapse: collapse;"> <tr> <td style="width: 50%;">CMPS•RPM(REF)</td> <td style="width: 50%;">737rpm</td> </tr> <tr> <td>MAS AIR/FL SE</td> <td>1.20V</td> </tr> <tr> <td>IACV-AAC/V</td> <td>26%</td> </tr> </table> </div>		CMPS•RPM(REF)	737rpm	MAS AIR/FL SE	1.20V	IACV-AAC/V	26%				
CMPS•RPM(REF)	737rpm										
MAS AIR/FL SE	1.20V										
IACV-AAC/V	26%										
<table style="margin: 0 auto;"> <tr> <td style="border: 1px solid black; padding: 2px;">1</td> <td style="border: 1px solid black; padding: 2px;">2</td> <td style="border: 1px solid black; padding: 2px;">3</td> <td style="border: 1px solid black; padding: 2px;">4</td> <td style="border: 1px solid black; padding: 2px;">TEST</td> </tr> <tr> <td style="border: 1px solid black; padding: 2px;">5</td> <td style="border: 1px solid black; padding: 2px;">6</td> <td style="border: 1px solid black; padding: 2px;"></td> <td style="border: 1px solid black; padding: 2px;"></td> <td style="border: 1px solid black; padding: 2px;">START</td> </tr> </table>		1	2	3	4	TEST	5	6			START
1	2	3	4	TEST							
5	6			START							
SEF389V											
3. Make sure that each circuit produces a momentary engine speed drop.											

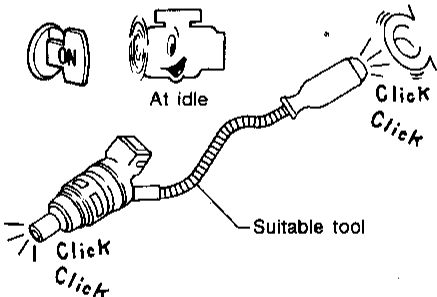
<p><b>ⓧ Without CONSULT</b></p> <ol style="list-style-type: none"> <li>Start engine.</li> <li>Listen to each injector operating sound.</li> </ol>	
	
Clicking noise should be heard.	
OK or NG	
OK	▶ INSPECTION END
NG	▶ GO TO 3.

MEC703B

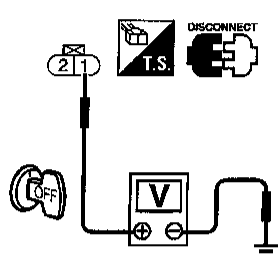
<b>3</b>	<b>CHECK POWER SUPPLY-I</b>
<ol style="list-style-type: none"> <li>Turn ignition switch "OFF".</li> <li>Disconnect injector harness connector.</li> <li>Check voltage between terminal 1 and ground with CONSULT or tester.</li> </ol>	
	
Voltage: Battery voltage	
OK or NG	
OK	▶ GO TO 5.
NG	▶ GO TO 4.

SEF671W

<b>4</b>	<b>DETECT MALFUNCTIONING PART</b>
Check the following.	
<ul style="list-style-type: none"> <li>• Harness connectors M59, F27</li> <li>• Harness connectors F37, F101</li> <li>• Fuse block (J/B) connector M26</li> <li>• 10A fuse</li> <li>• Harness for open or short between injector and fuse</li> </ul>	
▶ Repair harness or connectors.	

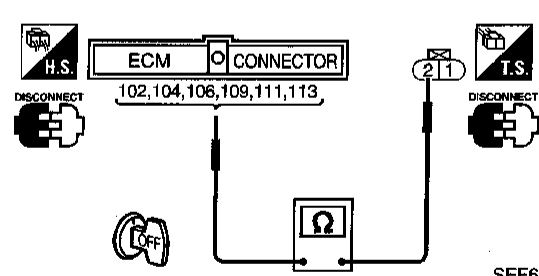
<b>5</b>	<b>CHECK OUTPUT SIGNAL CIRCUIT</b>
<ol style="list-style-type: none"> <li>Disconnect ECM harness connector.</li> <li>Check harness continuity between injector harness connector terminal 2 and ECM terminals 102, 104, 106, 109, 111, 113.</li> </ol>	
	
Continuity should exist.	
OK or NG	
OK	▶ GO TO 7.
NG	▶ GO TO 6.

SEF672W

# INJECTOR

## Diagnostic Procedure (Cont'd)

<b>6</b>	<b>DETECT MALFUNCTIONING PART</b>
Check the following. <ul style="list-style-type: none"> <li>• Harness connectors F37, F101</li> <li>• Harness connectors F38, F102</li> <li>• Harness for open or short between ECM and injector</li> </ul>	
▶	Repair open circuit or short to ground or short to power in harness or connectors.

<b>7</b>	<b>CHECK INJECTOR</b>
Refer to "Component Inspection" EC-462.	
<b>OK or NG</b>	
OK	▶
NG	▶
	GO TO 8.
	Replace injector.

<b>8</b>	<b>CHECK INTERMITTENT INCIDENT</b>
Refer to "TROUBLE DIAGNOSIS FOR INTERMITTENT INCIDENT", EC-115.	
▶	INSPECTION END

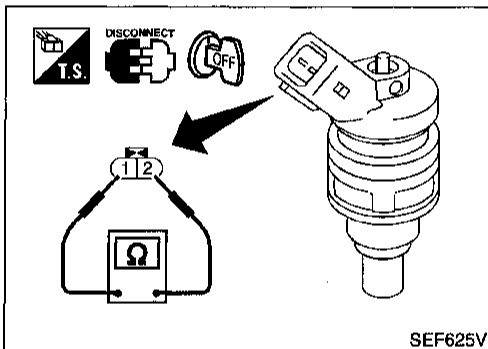

### Component Inspection INJECTOR

1. Disconnect injector harness connector.
2. Check resistance between terminals as shown in the figure.  
**Resistance: 10 - 14Ω [at 25°C (77°F)]**  
 If NG, replace injector.

NEEC0348

NEEC0348S01

# START SIGNAL

CONSULT Reference Value in Data Monitor Mode

## CONSULT Reference Value in Data Monitor Mode

NEEC0350

Specification data are reference values.

MONITOR ITEM	CONDITION	SPECIFICATION
START SIGNAL	• Ignition switch: ON → START → ON	OFF → ON → OFF

## ECM Terminals and Reference Value

NEEC0351

Specification data are reference values and are measured between each terminal and 32 (ECM ground).

TERMI- NAL NO.	WIRE COLOR	ITEM	CONDITION	DATA (DC Voltage)
20	L/OR	Start signal	[Ignition switch "ON"]	Approximately 0V
			[Ignition switch "START"]	BATTERY VOLTAGE (11 - 14V)

GI  
MA  
EM  
LC  
EC  
FE  
CL  
MT  
AT  
TF  
PD  
FA  
RA  
BR  
ST  
RS  
BT  
HA  
EL  
IDX

# START SIGNAL

Wiring Diagram

## Wiring Diagram

NEEC0349

### EC-S/SIG-01

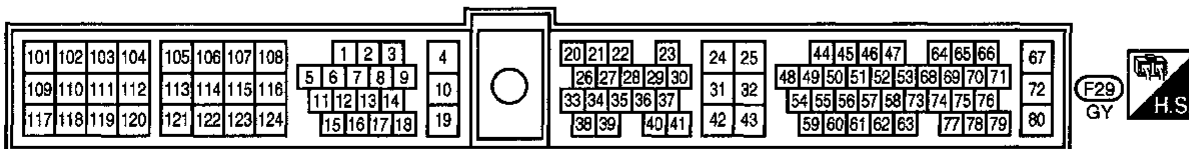
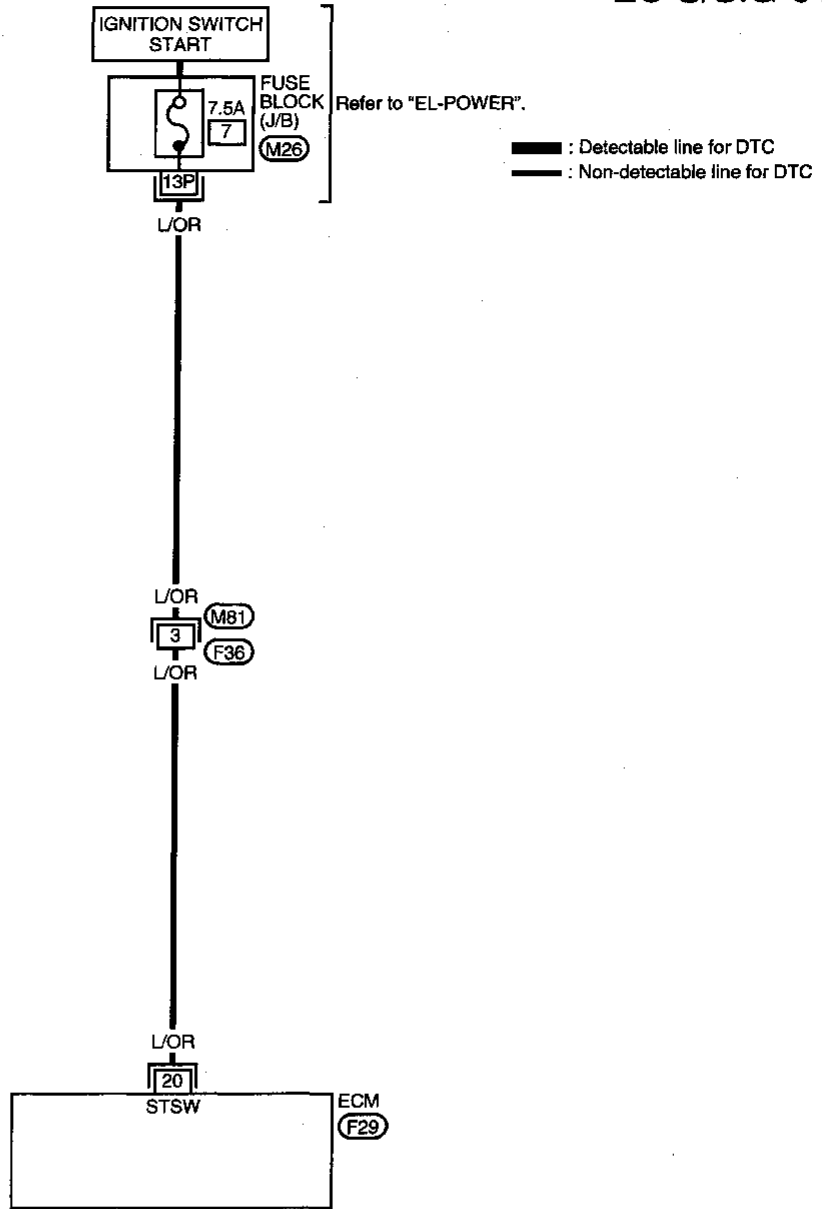

AEC768A

EC-464

## Diagnostic Procedure

NEEC0352

<b>1</b>	<b>INSPECTION START</b>
Do you have CONSULT?	
Yes or No	
Yes	▶ GO TO 2.
No	▶ GO TO 3.

<b>2</b>	<b>CHECK OVERALL FUNCTION</b>
<p><b>Ⓜ With CONSULT</b></p> <p>1. Turn ignition switch "ON".</p> <p>2. Perform "START SIGNAL CKT" in "FUNCTION TEST" mode with CONSULT.</p>	
<div style="border: 1px solid black; padding: 5px; width: fit-content; margin: 0 auto;"> <p>■ START SIGNAL CKT ■</p> <p>1. CLOSE THROTTLE. SHIFT TO P OR N RANGE.</p> <p>2. TOUCH START AND START ENGINE IMMEDIATELY.</p> </div>	
<div style="display: flex; justify-content: space-around; margin-top: 10px;"> <span style="border: 1px solid black; padding: 2px 10px;">NEXT</span> <span style="border: 1px solid black; padding: 2px 10px;">START</span> </div>	
SEF191L	

<p><b>Ⓜ With CONSULT</b></p> <p>1. Turn ignition switch "ON".</p> <p>2. Check "START SIGNAL" in "DATA MONITOR" mode with CONSULT under the following conditions.</p>									
<div style="border: 1px solid black; padding: 5px; width: fit-content; margin: 0 auto;"> <p>☆ MONITOR    ☆ NO FAIL    <input type="checkbox"/></p> <table style="width: 100%; border-collapse: collapse;"> <tr> <td>START SIGNAL</td> <td style="text-align: right;">OFF</td> </tr> <tr> <td>CLSD TH/P SW</td> <td style="text-align: right;">ON</td> </tr> <tr> <td>AIR COND SIG</td> <td style="text-align: right;">OFF</td> </tr> <tr> <td>P/N POSI SW</td> <td style="text-align: right;">ON</td> </tr> </table> </div>		START SIGNAL	OFF	CLSD TH/P SW	ON	AIR COND SIG	OFF	P/N POSI SW	ON
START SIGNAL	OFF								
CLSD TH/P SW	ON								
AIR COND SIG	OFF								
P/N POSI SW	ON								
<div style="border: 1px solid black; padding: 5px; width: fit-content; margin: 0 auto;">RECORD</div>									
SEF111P									
<table border="1" style="width: 100%; border-collapse: collapse;"> <tr> <th style="width: 50%;">Condition</th> <th style="width: 50%;">"START SIGNAL"</th> </tr> <tr> <td>Ignition switch "ON"</td> <td style="text-align: center;">OFF</td> </tr> <tr> <td>Ignition switch "START"</td> <td style="text-align: center;">ON</td> </tr> </table>		Condition	"START SIGNAL"	Ignition switch "ON"	OFF	Ignition switch "START"	ON		
Condition	"START SIGNAL"								
Ignition switch "ON"	OFF								
Ignition switch "START"	ON								
MTBL0147									
OK or NG									
OK	▶ INSPECTION END								
NG	▶ GO TO 4.								

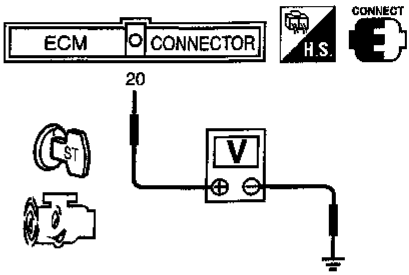
<b>3</b>	<b>CHECK OVERALL FUNCTION</b>						
<p><b>ⓧ Without CONSULT</b></p> <p>Check voltage between ECM terminal 20 and ground under the following conditions.</p>							
							
SEF733U							
<table border="1" style="width: 100%; border-collapse: collapse;"> <tr> <th style="width: 50%;">Condition</th> <th style="width: 50%;">Voltage</th> </tr> <tr> <td>Ignition switch "START"</td> <td style="text-align: center;">Battery voltage</td> </tr> <tr> <td>Other positions</td> <td style="text-align: center;">Approximately 0V</td> </tr> </table>		Condition	Voltage	Ignition switch "START"	Battery voltage	Other positions	Approximately 0V
Condition	Voltage						
Ignition switch "START"	Battery voltage						
Other positions	Approximately 0V						
MTBL0148							
OK or NG							
OK	▶ INSPECTION END						
NG	▶ GO TO 4.						

<b>4</b>	<b>CHECK STARTING SYSTEM</b>
<p>Turn ignition switch "OFF", then turn it to "START".</p> <p><b>Does starter motor operate?</b></p>	
Yes or No	
Yes	▶ GO TO 5.
No	▶ Refer to EL section "STARTING SYSTEM".

<b>5</b>	<b>CHECK FUSE</b>
<p>1. Turn ignition switch "OFF".</p> <p>2. Disconnect 7.5A fuse.</p> <p>3. Check if 7.5A fuse is OK.</p>	
OK or NG	
OK	▶ GO TO 6.
NG	▶ Replace 7.5A fuse.

GI  
MA  
EM  
LC  
EC  
FE  
CL  
MT  
AT  
TF  
PD  
FA  
RA  
BR  
ST  
RS  
BT  
HA  
EL  
IDX

# START SIGNAL

Diagnostic Procedure (Cont'd)

<b>6</b>	<b>CHECK INPUT SIGNAL CIRCUIT-II</b>	
<p>1. Disconnect ECM harness connector.                  2. Check harness continuity between ECM terminal 20 and fuse block.</p>		
SEF673W		
<p><b>Continuity should exist.</b></p> <p>3. Also check harness for short to ground and short to power.</p>		
<b>OK or NG</b>		
OK	▶	GO TO 8.
NG	▶	GO TO 7.

<b>7</b>	<b>DETECT MALFUNCTIONING PART</b>	
<p>Check the following.</p> <ul style="list-style-type: none"> <li>• Harness connectors M81, F36</li> <li>• Harness for open or short between ECM and fuse</li> </ul>		
▶		
<p>Repair open circuit or short to ground or short to power in harness or connectors.</p>		

<b>8</b>	<b>CHECK INTERMITTENT INCIDENT</b>	
<p>Refer to "TROUBLE DIAGNOSIS FOR INTERMITTENT INCIDENT", EC-115.</p>		
▶		
<p><b>INSPECTION END</b></p>		



# FUEL PUMP

System Description

## System Description

NEEC0353

Sensor	Input Signal to ECM	ECM function	Actuator
Camshaft position sensor	Engine speed	Fuel pump control	Fuel pump relay
Ignition switch	Start signal		

The ECM activates the fuel pump for several seconds after the ignition switch is turned on to improve engine startability. If the ECM receives a 120° signal from the camshaft position sensor, it knows that the engine is rotating, and causes the pump to operate. If the 120° signal is not received when the ignition switch is on, the engine stalls. The ECM stops pump operation and prevents battery discharging, thereby improving safety. The ECM does not directly drive the fuel pump. It controls the ON/OFF fuel pump relay, which in turn controls the fuel pump.

Condition	Fuel pump operation
Ignition switch is turned to ON.	Operates for 5 seconds
Engine running and cranking	Operates
When engine is stopped	Stops in 1.5 seconds
Except as shown above	Stops

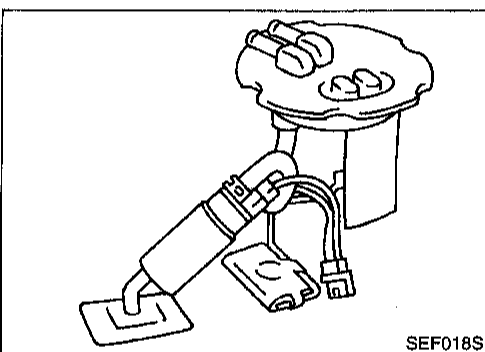

## Component Description

NEEC0538

The fuel pump with a fuel damper is an in-tank type (the pump and damper are located in the fuel tank).

## CONSULT Reference Value in Data Monitor Mode

NEEC0354

Specification data are reference values.

MONITOR ITEM	CONDITION	SPECIFICATION
FUEL PUMP RLY	<ul style="list-style-type: none"> <li>Ignition switch is turned to ON. (Operates for 5 seconds.)</li> <li>Engine running and cranking</li> </ul>	ON
	Except as shown above	OFF

## ECM Terminals and Reference Value

NEEC0355

Specification data are reference values and are measured between each terminal and 32 (ECM ground).

TERMINAL NO.	WIRE COLOR	ITEM	CONDITION	DATA (DC Voltage)
11	W/R	Fuel pump relay	[Ignition switch "ON"] <ul style="list-style-type: none"> <li>For 5 seconds after turning ignition switch "ON"</li> </ul> [Engine is running]	0 - 1V
			[Ignition switch "ON"] <ul style="list-style-type: none"> <li>More than 5 seconds after turning ignition switch "ON"</li> </ul>	BATTERY VOLTAGE (11 - 14V)

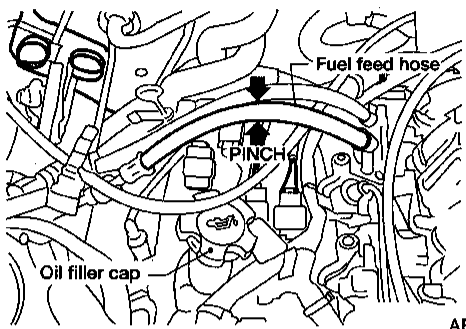

## Diagnostic Procedure

<b>1</b>	<b>CHECK OVERALL FUNCTION</b>
<ol style="list-style-type: none"> <li>Turn ignition switch "ON".</li> <li>Pinch fuel feed hose with fingers.</li> </ol>	
 <p style="text-align: right;">AEC663A</p> <p><b>Fuel pressure pulsation should be felt on the fuel feed hose for 5 seconds after ignition switch is turned "ON".</b></p> <p style="text-align: center;"><b>OK or NG</b></p>	
OK	▶ <b>INSPECTION END</b>
NG	▶ <b>GO TO 2.</b>

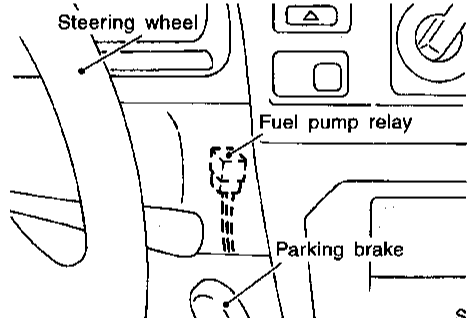
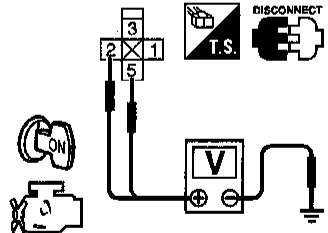
<b>2</b>	<b>CHECK POWER SUPPLY</b>
<ol style="list-style-type: none"> <li>Turn ignition switch "OFF".</li> <li>Disconnect fuel pump relay.</li> </ol>	
 <p style="text-align: right;">SEF349V</p>	
<ol style="list-style-type: none"> <li>Turn ignition switch "ON".</li> <li>Check voltage between terminals 2, 5 and ground with CONSULT or tester.</li> </ol>	
 <p style="text-align: right;">SEF674W</p> <p><b>Voltage: Battery voltage</b></p> <p style="text-align: center;"><b>OK or NG</b></p>	
OK	▶ <b>GO TO 4.</b>
NG	▶ <b>GO TO 3.</b>

<b>3</b>	<b>DETECT MALFUNCTIONING PART</b>
Check the following. <ul style="list-style-type: none"> <li>Fuse block (J/B) connector M31</li> <li>15A fuse</li> <li>Harness for open or short between fuse and fuel pump relay</li> </ul>	
▶ <b>Repair harness or connectors.</b>	

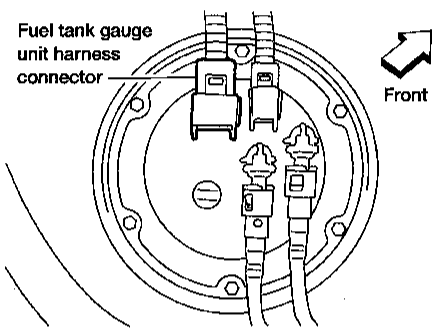
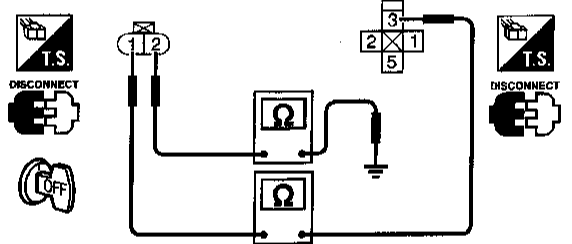
<b>4</b>	<b>CHECK POWER AND GROUND CIRCUIT</b>
<ol style="list-style-type: none"> <li>Turn ignition switch "OFF".</li> <li>Disconnect fuel pump harness connector.</li> </ol>	
 <p style="text-align: right;">AEC933A</p>	
<ol style="list-style-type: none"> <li>Check harness continuity between terminal 2 and body ground, terminal 1 and fuel pump relay terminal 3.</li> </ol>	
 <p style="text-align: right;">SEF675W</p> <p style="text-align: center;"><b>Continuity should exist.</b></p>	
<ol style="list-style-type: none"> <li>Also check harness for short to ground and short to power.</li> </ol>	
<b>OK or NG</b>	
OK	▶ <b>GO TO 6.</b>
NG	▶ <b>GO TO 5.</b>

<b>5</b>	<b>DETECT MALFUNCTIONING PART</b>
Check the following. <ul style="list-style-type: none"> <li>Harness connectors M67, C1</li> <li>Harness for open or short between fuel pump and body ground</li> <li>Harness for open or short between fuel pump and fuel pump relay</li> </ul>	
▶ <b>Repair open circuit or short to ground or short to power in harness or connectors.</b>	

GI  
MA  
EM  
LC  
EC  
FE  
CL  
MT  
AT  
TF  
PD  
FA  
RA  
BR  
ST  
RS  
BT  
HA  
EL  
IDX

# FUEL PUMP

Diagnostic Procedure (Cont'd)

<b>6</b>	<b>CHECK OUTPUT SIGNAL CIRCUIT</b>
<ol style="list-style-type: none"> <li>1. Disconnect ECM harness connector.</li> <li>2. Check harness continuity between ECM terminal 11 and fuel pump relay terminal 1.</li> </ol>	
<p>Continuity should exist.</p> <p>3. Also check harness for short to ground and short to power.</p>	
OK or NG	
OK	▶ GO TO 8.
NG	▶ GO TO 7.

<b>7</b>	<b>DETECT MALFUNCTIONING PART</b>
<p>Check the following.</p> <ul style="list-style-type: none"> <li>• Harness connectors M81, F36</li> <li>• Harness for open or short between ECM and fuel pump relay</li> </ul>	
▶ Repair open circuit or short to ground or short to power in harness or connectors.	

<b>8</b>	<b>CHECK FUEL PUMP RELAY</b>
<p><b>With CONSULT</b></p> <ol style="list-style-type: none"> <li>1. Reconnect fuel pump relay, fuel pump harness connector and ECM harness connector.</li> <li>2. Turn ignition switch "ON".</li> <li>3. Turn fuel pump relay "ON" and "OFF" in "ACTIVE TEST" mode with CONSULT and check operating sound.</li> </ol>	
MEF309F	
<p><b>Without CONSULT</b></p> <p>Refer to "Component Inspection", EC-470.</p>	
OK or NG	
OK	▶ GO TO 9.
NG	▶ Replace fuel pump relay.

<b>9</b>	<b>CHECK FUEL PUMP</b>
<p>Refer to "Component Inspection", EC-471.</p>	
OK or NG	
OK	▶ GO TO 10.
NG	▶ Replace fuel pump.

<b>10</b>	<b>CHECK INTERMITTENT INCIDENT</b>
<p>Refer to "TROUBLE DIAGNOSIS FOR INTERMITTENT INCIDENT", EC-115.</p>	
▶ INSPECTION END	

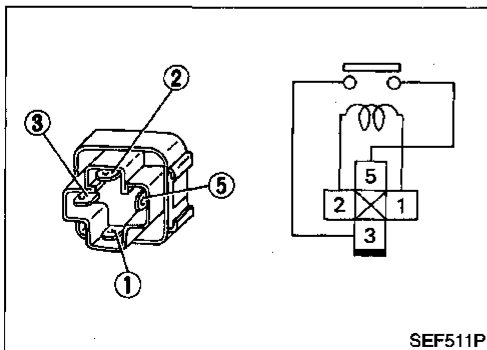

## Component Inspection

### FUEL PUMP RELAY

Check continuity between terminals 3 and 5.

NEEC0356

NEEC0358S01

Conditions	Continuity
12V direct current supply between terminals 1 and 2	Yes
No current supply	No

If NG, replace relay.

EC-470

# FUEL PUMP

Component Inspection (Cont'd)

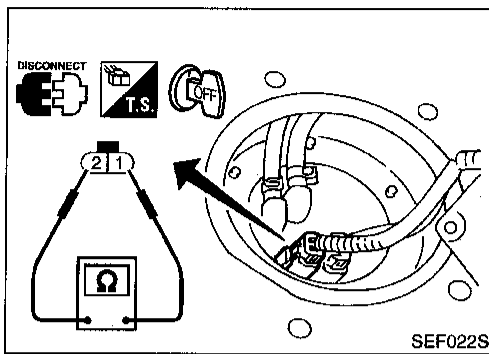

## FUEL PUMP

1. Disconnect fuel pump harness connector.
2. Check resistance between terminals 1 and 2.  
**Resistance: 0.2 - 5.0 $\Omega$  [at 25°C (77°F)]**  
If NG, replace fuel pump.

NEEC0358S02

GI

MA

EM

LC

**EC**

FE

CL

MT

AT

TF

PD

FA

RA

BR

ST

RS

BT

HA

EL

IDX

EC-471

# POWER STEERING OIL PRESSURE SWITCH

## Component Description

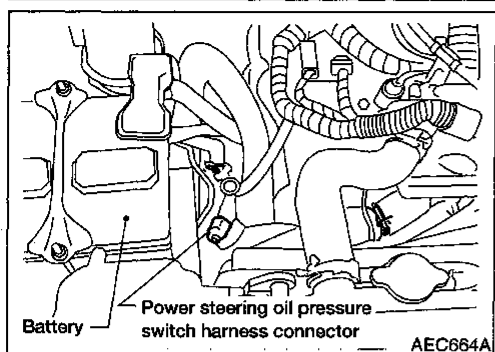

## Component Description

NEEC0360  
The power steering oil pressure switch is attached to the power steering high-pressure tube and detects a power steering load. When a power steering load is detected, it signals the ECM. The ECM adjusts the IACV-AAC valve to increase the idle speed and adjust for the increased load.

## CONSULT Reference Value in Data Monitor Mode

Specification data are reference values.

NEEC0361

MONITOR ITEM	CONDITION		SPECIFICATION
PW/ST SIGNAL	<ul style="list-style-type: none"> <li>Engine: After warming up, idle the engine</li> </ul>	Steering wheel in neutral position (forward direction)	OFF
		The steering wheel is fully turned.	ON

## ECM Terminals and Reference Value

Specification data are reference values and are measured between each terminal and 32 (ECM ground).

NEEC0362

TERMI-NAL NO.	WIRE COLOR	ITEM	CONDITION	DATA (DC Voltage)
39	GY/R	Power steering oil pressure switch	<b>[Engine is running]</b> <ul style="list-style-type: none"> <li>Steering wheel is being fully turned</li> </ul>	0V
			<b>[Engine is running]</b> <ul style="list-style-type: none"> <li>Steering wheel is not being turned</li> </ul>	Approximately 5V

# POWER STEERING OIL PRESSURE SWITCH

Wiring Diagram

## Wiring Diagram

NEEC0359

EC-PST/SW-01

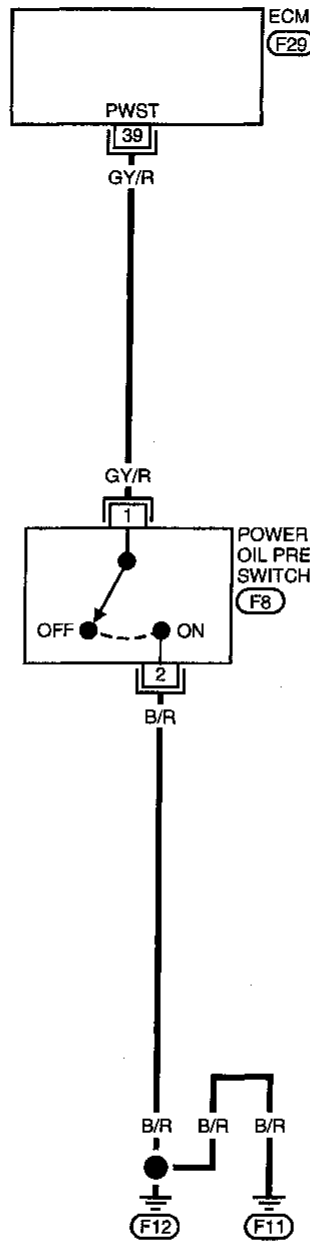

— : Detectable line for DTC  
 - - - : Non-detectable line for DTC

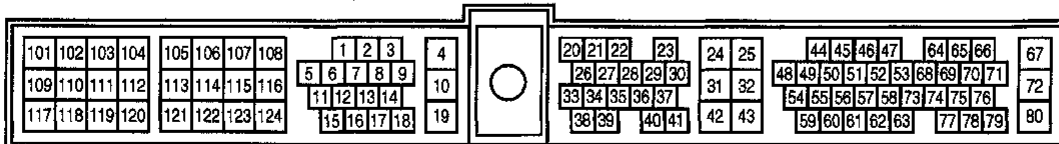
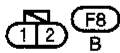

AEC770A

EC-473

GI  
 MA  
 EM  
 LC  
**EC**  
 FE  
 CL  
 MT  
 AT  
 TF  
 PD  
 FA  
 RA  
 BR  
 ST  
 RS  
 BT  
 HA  
 EL  
 IDX

# POWER STEERING OIL PRESSURE SWITCH

Diagnostic Procedure

## Diagnostic Procedure

NEEC0363

<b>1</b>	<b>INSPECTION START</b>	
Do you have CONSULT?		
<b>Yes or No</b>		
Yes	▶	GO TO 2.
No	▶	GO TO 3.

<b>2</b>	<b>CHECK OVERALL FUNCTION</b>	
<p><b>With CONSULT</b></p> <p>1. Turn ignition switch "ON".</p> <p>2. Perform "PW/ST SIGNAL CIRCUIT" in "FUNCTION TEST" mode with CONSULT.</p>		
<p>■ PW/ST SIGNAL CIRCUIT ■</p> <p>HOLD STEERING WHEEL IN A FULL LOCKED POSITION THEN TOUCH START</p> <p>NEXT      START</p>		
MEF023E		

<p><b>With CONSULT</b></p> <p>1. Start engine.</p> <p>2. Check "PW/ST SIGNAL" in "DATA MONITOR" mode with CONSULT.</p>								
<p>☆ MONITOR    ☆ NO FAIL    <input type="checkbox"/></p> <p>PW/ST SIGNAL      OFF</p> <p>RECORD</p>								
SEF5911								
<table border="1"> <thead> <tr> <th>Condition</th> <th>"PW/ST SIGNAL"</th> </tr> </thead> <tbody> <tr> <td>Steering is neutral position</td> <td>OFF</td> </tr> <tr> <td>Steering is turned to full position</td> <td>ON</td> </tr> </tbody> </table>			Condition	"PW/ST SIGNAL"	Steering is neutral position	OFF	Steering is turned to full position	ON
Condition	"PW/ST SIGNAL"							
Steering is neutral position	OFF							
Steering is turned to full position	ON							
MTBL0144								
<b>OK or NG</b>								
OK	▶	INSPECTION END						
NG	▶	GO TO 4.						

<b>3</b>	<b>CHECK OVERALL FUNCTION</b>							
<p><b>Without CONSULT</b></p> <p>1. Start engine.</p> <p>2. Check voltage between ECM terminal 39 and ground.</p>								
<p style="text-align: right;">SEF739U</p>								
<table border="1"> <thead> <tr> <th>Condition</th> <th>Voltage</th> </tr> </thead> <tbody> <tr> <td>Steering is neutral position</td> <td>Approximately 5V</td> </tr> <tr> <td>Steering is turned to full position</td> <td>Approximately 0V</td> </tr> </tbody> </table>			Condition	Voltage	Steering is neutral position	Approximately 5V	Steering is turned to full position	Approximately 0V
Condition	Voltage							
Steering is neutral position	Approximately 5V							
Steering is turned to full position	Approximately 0V							
MTBL0145								
<b>OK or NG</b>								
OK	▶	INSPECTION END						
NG	▶	GO TO 4.						



# POWER STEERING OIL PRESSURE SWITCH

Diagnostic Procedure (Cont'd)

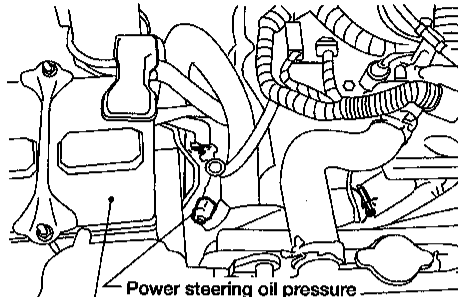
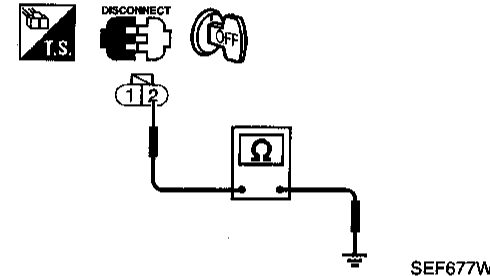
<b>4</b>	<b>CHECK GROUND CIRCUIT</b>
<ol style="list-style-type: none"> <li>1. Turn ignition switch "OFF".</li> <li>2. Disconnect power steering oil pressure switch harness connector.</li> </ol>	
 <p>Battery Power steering oil pressure switch harness connector</p> <p style="text-align: right;">AEC664A</p>	
<ol style="list-style-type: none"> <li>3. Check harness continuity between terminal 2 and engine ground.</li> </ol>	
 <p style="text-align: right;">SEF677W</p>	
<p><b>Continuity should exist.</b></p>	
<ol style="list-style-type: none"> <li>4. Also check harness for short to ground and short to power.</li> </ol>	
<p><b>OK or NG</b></p>	
OK	▶ GO TO 5.
NG	▶ Repair open circuit or short to ground or short to power in harness or connectors.

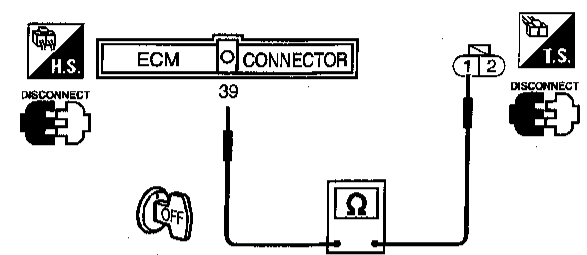
<b>5</b>	<b>CHECK INPUT SIGNAL CIRCUIT</b>
<ol style="list-style-type: none"> <li>1. Disconnect ECM harness connector.</li> <li>2. Check harness continuity between ECM terminal 39 and terminal 1.</li> </ol>	
 <p style="text-align: right;">SEF678W</p>	
<p><b>Continuity should exist.</b></p>	
<ol style="list-style-type: none"> <li>3. Also check harness for short to ground and short to power.</li> </ol>	
<p><b>OK or NG</b></p>	
OK	▶ GO TO 6.
NG	▶ Repair open circuit or short to ground or short to power in harness or connectors.

<b>6</b>	<b>CHECK POWER STEERING OIL PRESSURE SWITCH</b>
Refer to "Component Inspection", EC-476.	
<p><b>OK or NG</b></p>	
OK	▶ GO TO 7.
NG	▶ Replace power steering oil pressure switch.

<b>7</b>	<b>CHECK INTERMITTENT INCIDENT</b>
Refer to "TROUBLE DIAGNOSIS FOR INTERMITTENT INCIDENT", EC-115.	
<p>▶ <b>INSPECTION END</b></p>	

GI  
MA  
EM  
LC  
EC  
FE  
CL  
MT  
AT  
TF  
PD  
FA  
RA  
BR  
ST  
RS  
BT  
HA  
EL  
IDX

# POWER STEERING OIL PRESSURE SWITCH

## Component Inspection

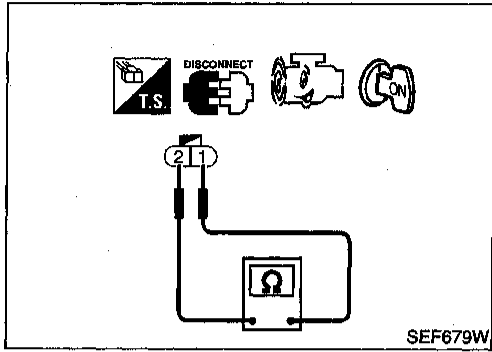

## Component Inspection

### POWER STEERING OIL PRESSURE SWITCH

=NEEC0364

NEEC0364S01

1. Disconnect power steering oil pressure switch harness connector then start engine.
2. Check continuity between terminals 1 and 2.

Conditions	Continuity
Steering wheel is being fully turned	Yes
Steering wheel is not being turned	No

If NG, replace power steering oil pressure switch.

# IACV-FICD SOLENOID VALVE

Component Description

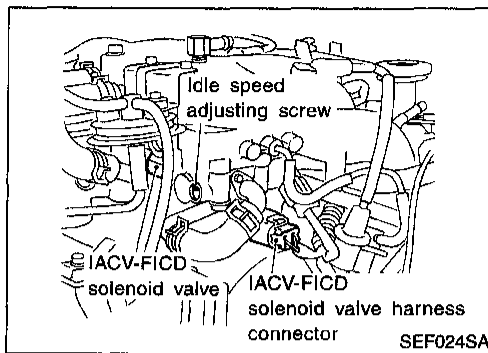

## Component Description

NEEC0366

When the air conditioner is on, the IACV-FICD solenoid valve supplies additional air to adjust to the increased load. For more information, refer to "DESCRIPTION" in HA section.

## ECM Terminals and Reference Value

NEEC0367

Specification data are reference values and are measured between each terminal and 32 (ECM ground).

TERMI- NAL NO.	WIRE COLOR	ITEM	CONDITION	DATA (DC Voltage)
9	B/Y	Ambient air temperature switch	[Engine is running] • Idle speed • Ambient air temperature is above 25°C (77°F) • Air conditioner is operating	0V
			[Engine is running] • Idle speed • Ambient air temperature is below 19°C (66°F) • Air conditioner is operating	BATTERY VOLTAGE (11 - 14V)
			[Engine is running] • Idle speed • Ambient air temperature is below 19°C (66°F) • Air conditioner is not operating	Approximately 5V
12	P	Air conditioner relay	[Engine is running] • Both A/C switch and blower fan switch are "ON"*	0 - 1V
			[Engine is running] • A/C switch is "OFF"	BATTERY VOLTAGE (11 - 14V)
21	G/R	Air conditioner switch	[Engine is running] • Both A/C switch and blower fan switch are "ON" (Compressor operates)*	Approximately 0V
			[Engine is running] • Air conditioner switch is "OFF"	Approximately 5V

\*: Any mode except "OFF", ambient air temperature is above 25°C (77°F).

# IACV-FICD SOLENOID VALVE

Wiring Diagram

## Wiring Diagram

NEEC0365

EC-FICD-01

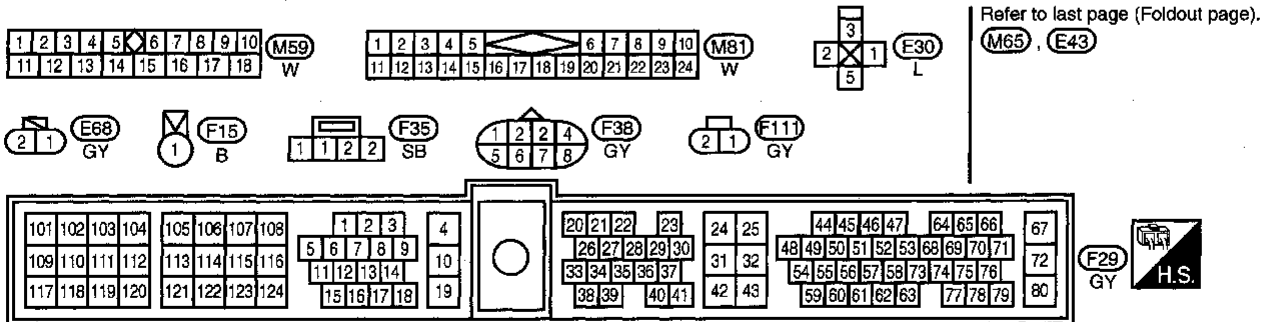
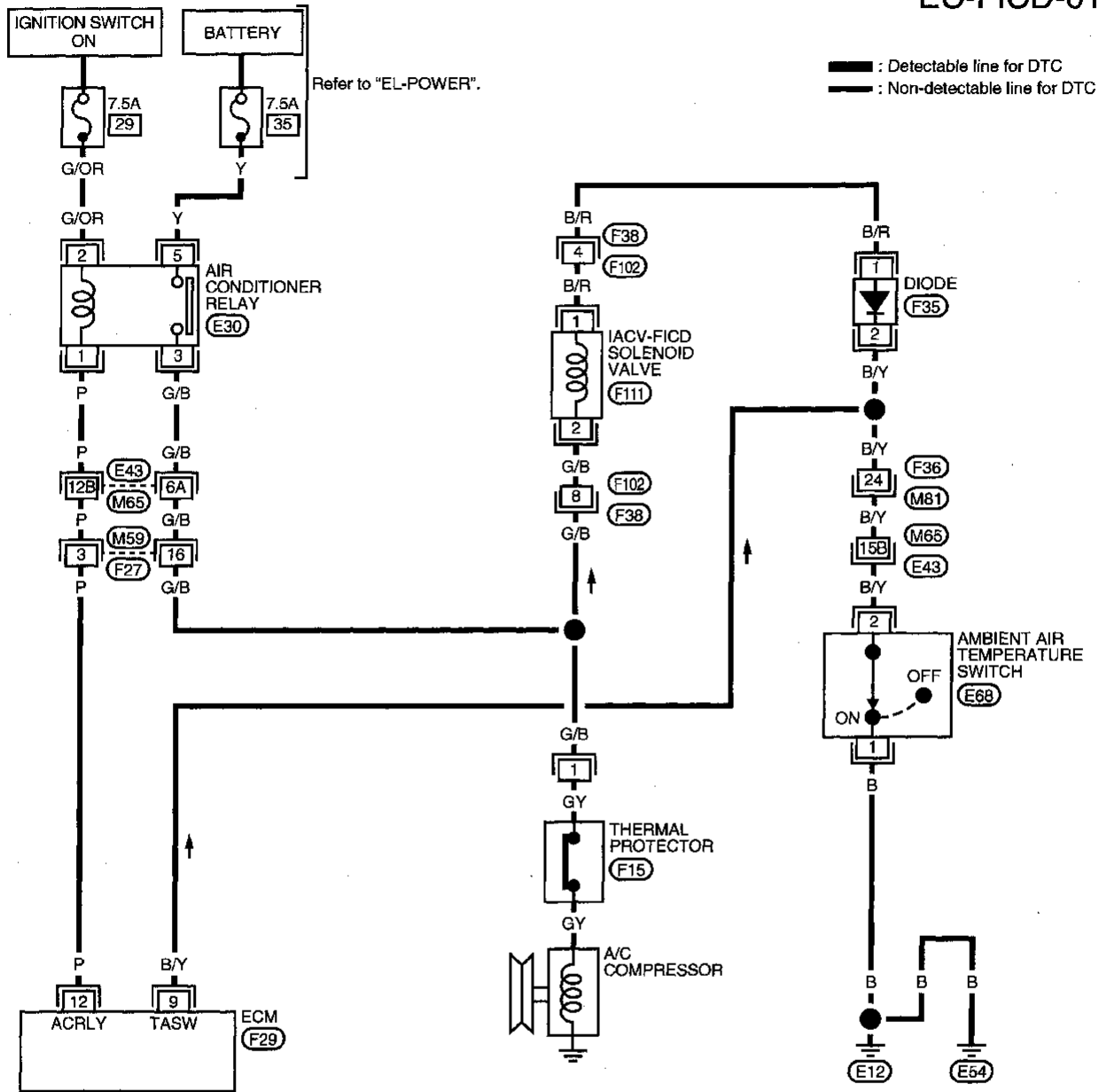

EC-478

AEC771A

## Diagnostic Procedure

<b>1</b>	<b>CHECK OVERALL FUNCTION</b>
<ol style="list-style-type: none"> <li>Start engine and warm it up to normal operating temperature.</li> <li>Check idle speed. <b>750±50 rpm (In "N" position)</b> If NG, adjust idle speed.</li> <li>Turn air conditioner switch and blower fan switch "ON".</li> <li>Recheck idle speed.</li> </ol>	
<p><b>850 rpm or more (in "P" or "N" position)</b></p> <p><b>OK or NG</b></p>	
OK	▶ <b>INSPECTION END</b>
NG	▶ <b>GO TO 2.</b>

<b>2</b>	<b>CHECK AIR CONDITIONER FUNCTION</b>
Check if air conditioner compressor functions normally.	
<b>OK or NG</b>	
OK	▶ <b>GO TO 3.</b>
NG	▶ <b>Refer to HA section ("TROUBLE DIAGNOSES").</b>

<b>3</b>	<b>CHECK POWER SUPPLY</b>
<ol style="list-style-type: none"> <li>Turn air conditioner switch and blower fan switch "OFF".</li> <li>Stop engine.</li> <li>Disconnect IACV-FICD solenoid valve harness connector.</li> </ol>	
<ol style="list-style-type: none"> <li>Start engine, then turn air conditioner switch and blower fan switch "ON".</li> <li>Check voltage between terminal 2 and ground with CONSULT or tester.</li> </ol>	
<p><b>Voltage: Battery voltage</b></p> <p><b>OK or NG</b></p>	
OK	▶ <b>GO TO 5.</b>
NG	▶ <b>GO TO 4.</b>

<b>4</b>	<b>DETECT MALFUNCTIONING PART</b>
Check the following.	
<ul style="list-style-type: none"> <li>Harness connectors F38, F102</li> <li>Harness for open or short between IACV-FICD solenoid valve and harness connector F27</li> </ul>	
▶ <b>Repair harness or connectors.</b>	

GI  
MA  
EM  
LC  
EC  
FE  
CL  
MT  
AT  
TF  
PD  
FA  
RA  
BR  
ST  
RS  
BT  
HA  
EL  
IDX

# IACV-FICD SOLENOID VALVE

Diagnostic Procedure (Cont'd)

<b>5</b>	<b>CHECK GROUND CIRCUIT</b>
<ol style="list-style-type: none"> <li>Turn ignition switch "OFF".</li> <li>Disconnect ambient air temperature switch harness connector.</li> <li>Check harness continuity between switch terminal 1 and body ground, switch terminal 2 and solenoid valve terminal 1.</li> </ol>	
<p><b>Continuity should exist.</b></p>	
<ol style="list-style-type: none"> <li>Also check harness for short to ground and short to power.</li> </ol>	
<b>OK or NG</b>	
OK	▶ GO TO 7.
NG	▶ GO TO 6.

<b>6</b>	<b>DETECT MALFUNCTIONING PART</b>
<p>Check the following.</p> <ul style="list-style-type: none"> <li>• Harness connectors F38, F102</li> <li>• Harness connectors F36, M81</li> <li>• Harness connectors M65, E43</li> <li>• Diode F35</li> <li>• Harness for open or short between ambient air temperature switch and body ground</li> <li>• Harness for open or short between IACV-FICD solenoid valve and ambient air temperature switch</li> </ul>	
▶	Repair open circuit or short to ground or short to power in harness or connectors.

<b>7</b>	<b>CHECK AMBIENT AIR TEMPERATURE SWITCH</b>
Refer to HA section.	
<b>OK or NG</b>	
OK	▶ GO TO 8.
NG	▶ Replace ambient air temperature switch.

<b>8</b>	<b>CHECK IACV-FICD SOLENOID VALVE</b>
Refer to "Component Inspection", EC-480.	
<b>OK or NG</b>	
OK	▶ GO TO 9.
NG	▶ Replace IACV-FICD solenoid valve.

<b>9</b>	<b>CHECK INTERMITTENT INCIDENT</b>
Refer to "TROUBLE DIAGNOSIS FOR INTERMITTENT INCIDENT", EC-115.	
▶	<b>INSPECTION END</b>

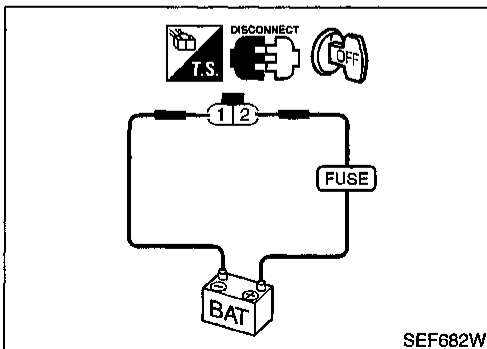

## Component Inspection IACV-FICD SOLENOID VALVE

Disconnect IACV-FICD solenoid valve harness connector.

- Check for clicking sound when applying 12V direct current to terminals.

NEEC0369

NEEC0369S01

# IACV-FICD SOLENOID VALVE

Component Inspection (Cont'd)

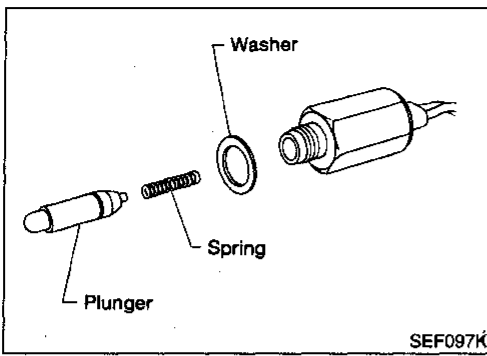

- Check plunger for seizing or sticking.
- Check for broken spring.

GI

MA

EM

LC

**EC**

FE

CL

MT

AT

TF

PD

FA

RA

BR

ST

RS

BT

HA

EL

IDX

# MIL & DATA LINK CONNECTORS

Wiring Diagram

## Wiring Diagram

NEEC0370

EC-MIL/DL-01

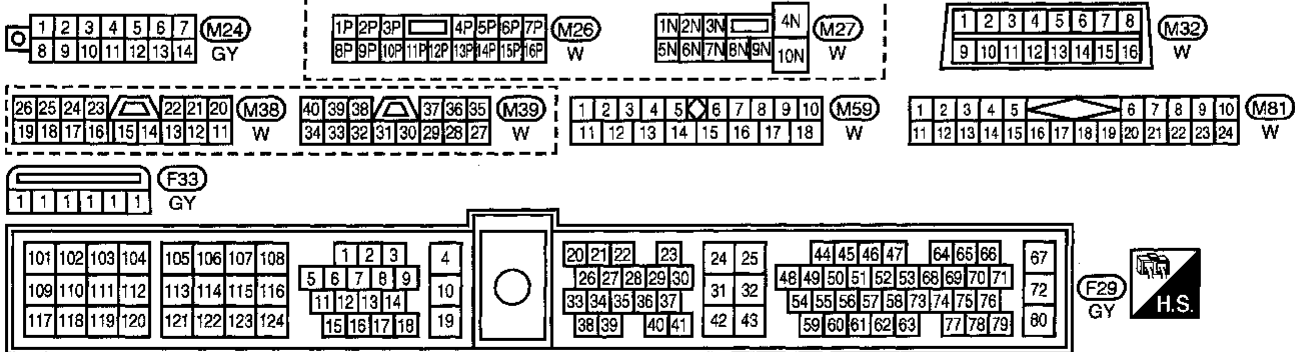
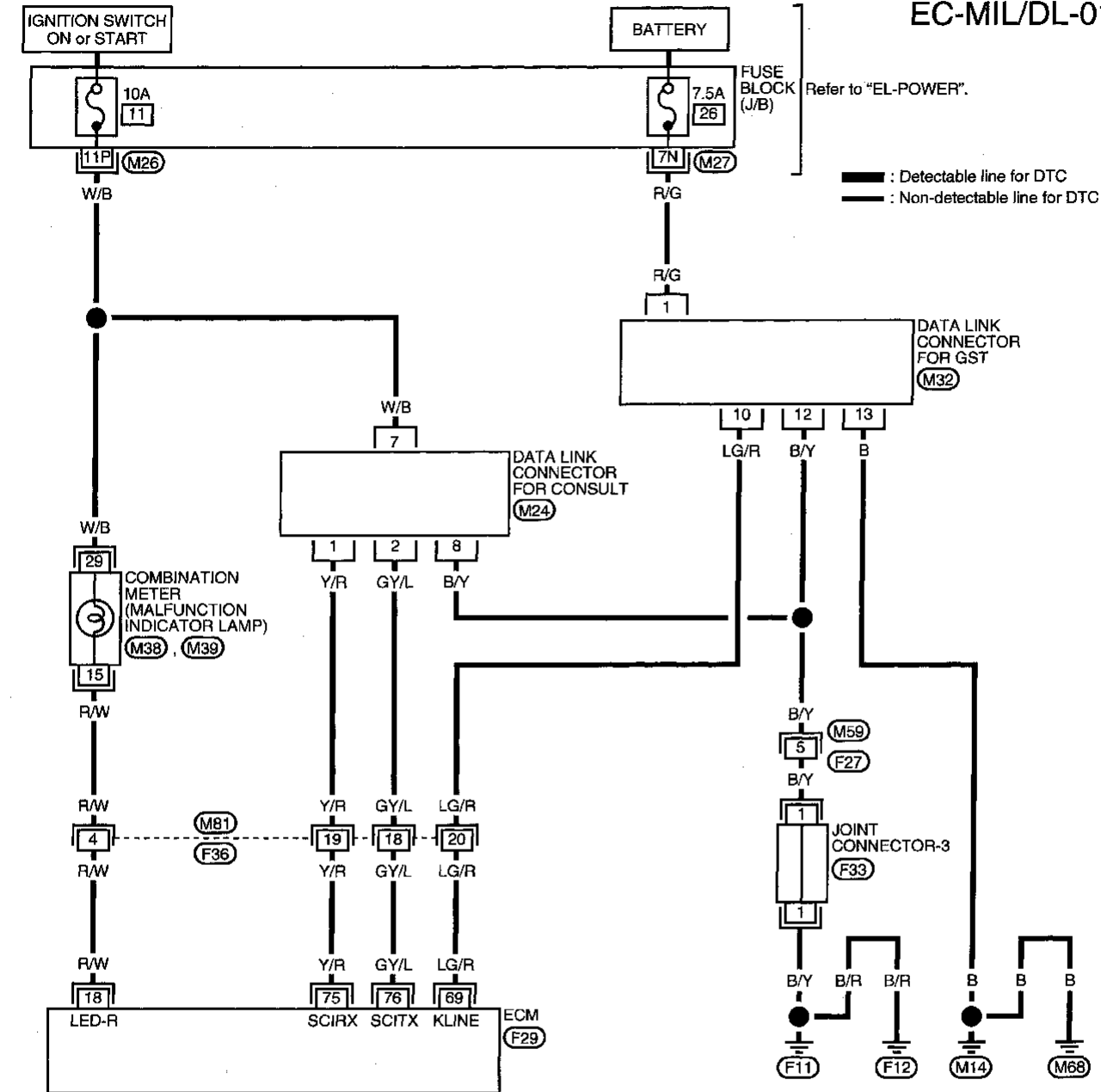

AEC772A



# SERVICE DATA AND SPECIFICATIONS (SDS)

Fuel Pressure Regulator

## Fuel Pressure Regulator

NEEC0371

Fuel pressure at idling kPa (kg/cm <sup>2</sup> , psi)		
Vacuum hose is connected		Approximately 235 (2.4, 34)
Vacuum hose is disconnected		Approximately 294 (3.0, 43)

## Idle Speed and Ignition Timing

NEEC0372

Base idle speed*1	No-load*4 (in "P" or N" position)	700±50 rpm
Target idle speed*2	No-load*4 (in "P" or N" position)	750±50 rpm
Air conditioner: ON	In "P" or N" position	850 rpm or more
Ignition timing*3	In "P" or N" position	15°±2° BTDC
Throttle position sensor idle position		0.4 - 0.6V

\*1: Throttle position sensor harness connector disconnected or using CONSULT "WORK SUPPORT" mode

\*2: Throttle position sensor harness connector connected

\*3: Throttle position sensor harness connector disconnected

\*4: Under the following conditions:

- Air conditioner switch: OFF
- Electric load: OFF (Lights, heater fan & rear window defogger)
- Steering wheel: Kept in straight-ahead position

## Ignition Coil

NEEC0373

Primary voltage	12V
Primary resistance [at 20°C (68°F)]	Approximately 1.0Ω
Secondary resistance [at 20°C (68°F)]	Approximately 10 kΩ

## Mass Air Flow Sensor

NEEC0374

Supply voltage	Battery voltage (11 - 14)V
Output voltage at idle	1.0 - 1.7*V
Mass air flow (Using CONSULT or GST)	3.3 - 4.8 g-m/sec at idle* 12.0 - 14.9 g-m/sec at 2,500 rpm*

\*: Engine is warmed up sufficiently and running under no-load.

## Engine Coolant Temperature Sensor

NEEC0375

Temperature °C (°F)	Resistance kΩ
20 (68)	2.1 - 2.9
50 (122)	0.68 - 1.00
90 (194)	0.236 - 0.260

## EGR Temperature Sensor

NEEC0376

EGR temperature °C (°F)	Voltage (V)	Resistance (MΩ)
0 (32)	4.81	7.9 - 9.7
50 (122)	2.82	0.57 - 0.70
100 (212)	0.8	0.08 - 0.10

## Front Heated Oxygen Sensor Heater

NEEC0377

Resistance [at 25°C (77°F)]	2.3 - 4.3Ω
-----------------------------	------------

# SERVICE DATA AND SPECIFICATIONS (SDS)

## Fuel Pump

### Fuel Pump NEEC0378

Resistance [at 25°C (77°F)]	0.2 - 5.0Ω
-----------------------------	------------

### IACV-AAC Valve NEEC0379

Resistance [at 20°C (68°F)]	Approximately 10.0Ω
-----------------------------	---------------------

### Injector NEEC0380

Resistance [at 25°C (77°F)]	10 - 14Ω
-----------------------------	----------

### Resistor NEEC0381

Resistance [at 25°C (77°F)]	Approximately 2.2 kΩ
-----------------------------	----------------------

### Throttle Position Sensor NEEC0382

Throttle valve conditions	Voltage (at normal operating temperature, engine off, ignition switch ON, throttle opener disengaged)
Completely closed (a)	0.15 - 0.85V
Partially open	Between (a) and (b)
Completely open (b)	3.5 - 4.7V

### Calculated Load Value NEEC0383

	Calculated load value % (Using CONSULT or GST)
At idle	18.0 - 26.0
At 2,500 rpm	18.0 - 21.0

### Intake Air Temperature Sensor NEEC0384

Temperature °C (°F)	Resistance kΩ
20 (68)	2.1 - 2.9
80 (176)	0.27 - 0.38

### Rear Heated Oxygen Sensor Heater NEEC0385

Resistance [at 25°C (77°F)]	2.3 - 4.3Ω
-----------------------------	------------

### Crankshaft Position Sensor (OBD) NEEC0386

Resistance [at 20°C (68°F)]	166.5 - 203.5Ω
-----------------------------	----------------

### Tank Fuel Temperature Sensor NEEC0521

Temperature °C (°F)	Resistance kΩ
20 (68)	2.3 - 2.7
50 (122)	0.79 - 0.90