

ACCELERATOR CONTROL, FUEL & EXHAUST SYSTEMS

GI
MA
EM
LC
EC
FE
CL
MT
AT
TF
PD
FA
RA
BR
ST
RS
BT
HA
EL
IDX

SECTION FE

CONTENTS

PREPARATION	2	Fuel Tank	5
Special Service Tools	2	Removal	5
ACCELERATOR CONTROL SYSTEM	3	Installation	6
Accelerator Control System.....	3	Fuel Pump and Gauge	7
Adjusting Accelerator Wire	3	Removal And Installation	7
FUEL SYSTEM	4	EXHAUST SYSTEM	8

PREPARATION

Special Service Tools

The actual shapes of Kent-Moore tools may differ from those of special service tools illustrated here.

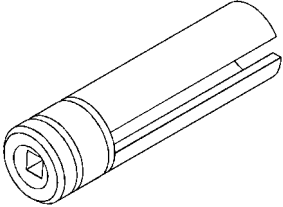
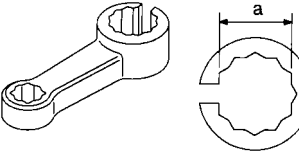
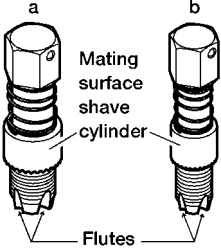
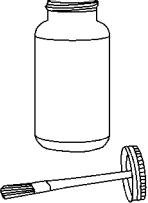
Tool number (Kent-Moore No.) Tool name	Description
KV10117100 (J3647-A) Heated oxygen sensor wrench	 <p data-bbox="1027 363 1495 417">Loosening or tightening rear heated oxygen sensor (For left bank)</p> <p data-bbox="461 604 516 625">NT379</p> <p data-bbox="1027 604 1360 625">For 22 mm (0.87 in) hexagon nut</p>
KV10114400 (J38365) Heated oxygen sensor wrench	 <p data-bbox="1027 646 1495 701">Loosening or tightening rear heated oxygen sensor (For right bank)</p> <p data-bbox="461 829 516 850">NT636</p> <p data-bbox="1027 829 1211 850">a: 22 mm (0.87 in)</p>
Tool name (Kent-Moore No.)	Description
Oxygen sensor thread cleaner (J-43897-18) (J-43897-12)	 <p data-bbox="1027 961 1495 1171">Reconditioning the exhaust system threads before installing a new oxygen sensor. Use with anti-seize lubricant shown below - A: J-43897-18 18 mm Diameter, For Zirconia oxygen sensor B: J-43897-12 12 mm Diameter, Titania oxygen sensor.</p> <p data-bbox="461 1234 532 1255">AEM488</p>
Anti-seize Lubricant Permatex™ 133AR or equivalent meeting MIL - Specification MIL-A-907	 <p data-bbox="1027 1276 1495 1360">Lubricating oxygen sensor thread. Cleaning tool when reconditioning exhaust system threads.</p> <p data-bbox="461 1549 532 1570">AEM489</p>

ACCELERATOR CONTROL SYSTEM

Accelerator Control System

CAUTION:

- When removing accelerator wire, make a mark to indicate lock nut's initial position.
- Check that throttle valve opens fully when accelerator pedal is fully depressed. Also check that it returns to idle position when pedal is released.
- Check accelerator control parts for improper contact with any adjacent parts.
- When connecting accelerator wire, be careful not to twist or scratch its inner wire.
- Refer to EL section ("AUTOMATIC SPEED CONTROL DEVICE") for ASCD wire adjustment.

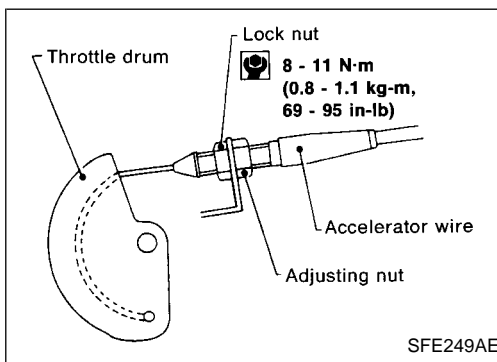
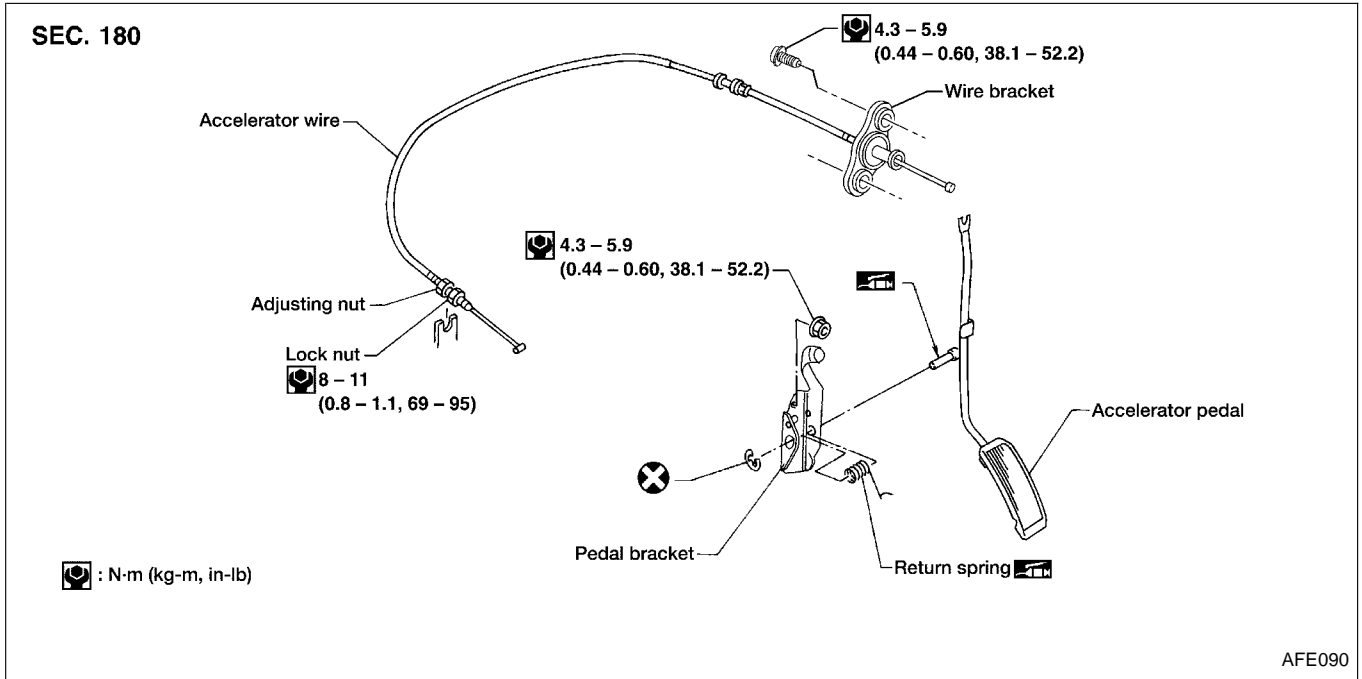

Adjusting Accelerator Wire

1. Loosen lock nut, and tighten adjusting nut until throttle drum starts to move.
2. From that position, turn back adjusting nut 1.5 to 2 turns, and secure lock nut.

Fuel Tank

REMOVAL

1. Release fuel pressure from fuel line.
Refer to MA section ("Changing Fuel Filter").
2. Disconnect battery ground cable.
3. Drain fuel from fuel tank.
4. Disconnect electrical connector.
5. Remove filler protector.
6. Remove the quick connector as follows.
 - a. Put mating marks on tubes and connectors for correct installation.
 - b. Hold the sides of the connector, push in tabs, and pull out the tube inserted in the retainer.

GI
MA
EM
LC
EC
FE
CL
MT
AT
TF
PD
FA
RA
BR
ST
RS
BT
HA
EL
IDX

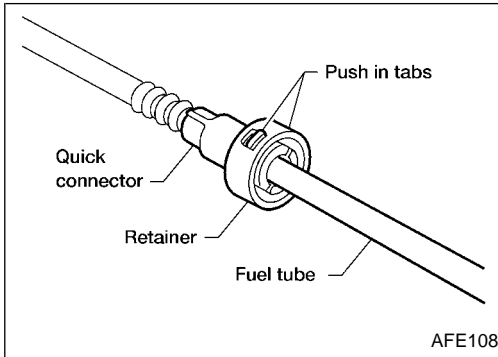

- CAUTION:**
- The tube can be removed when the push in tabs are completely depressed. Do not twist it more than necessary.
 - Do not use any tools to remove the quick connector.

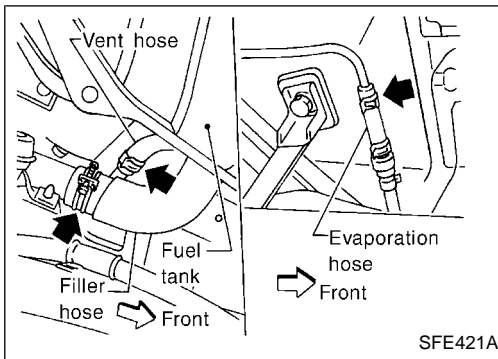

7. Disconnect filler hose, vent hose and evaporation hose at fuel tank side.

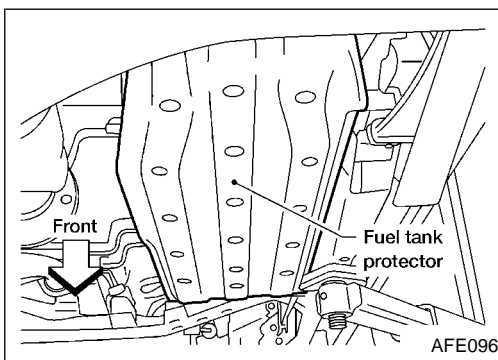

8. Remove fuel tank protector.

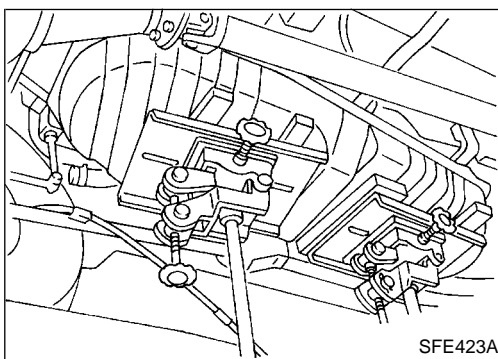

9. Remove fuel tank mounting bolts while supporting fuel tank.
10. Remove fuel tank.

FUEL SYSTEM

Fuel Tank (Cont'd)

INSTALLATION

To install, reverse the removal procedure. Connect the quick connector as follows:

- Align push in tabs with retainer openings.
- Insert the tube into the center of the connector until you hear a click.

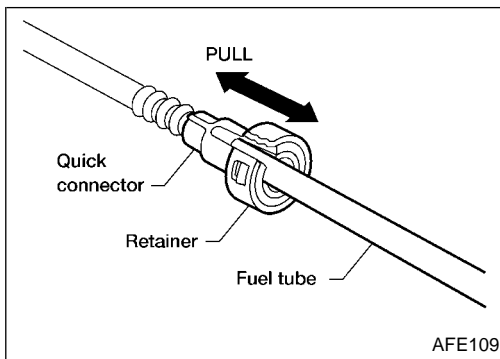
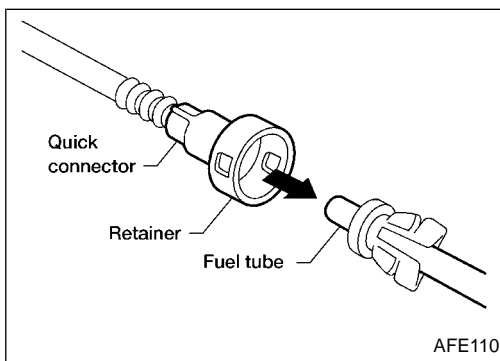

After connecting quick connector, make sure the connection is firmly made using the following method.

- Pull on the fuel tube and connector to make sure they are firmly connected.
- Start the engine, increase engine speed and verify that there are no leaks.

FUEL SYSTEM

Fuel Pump and Gauge

SEC. 172

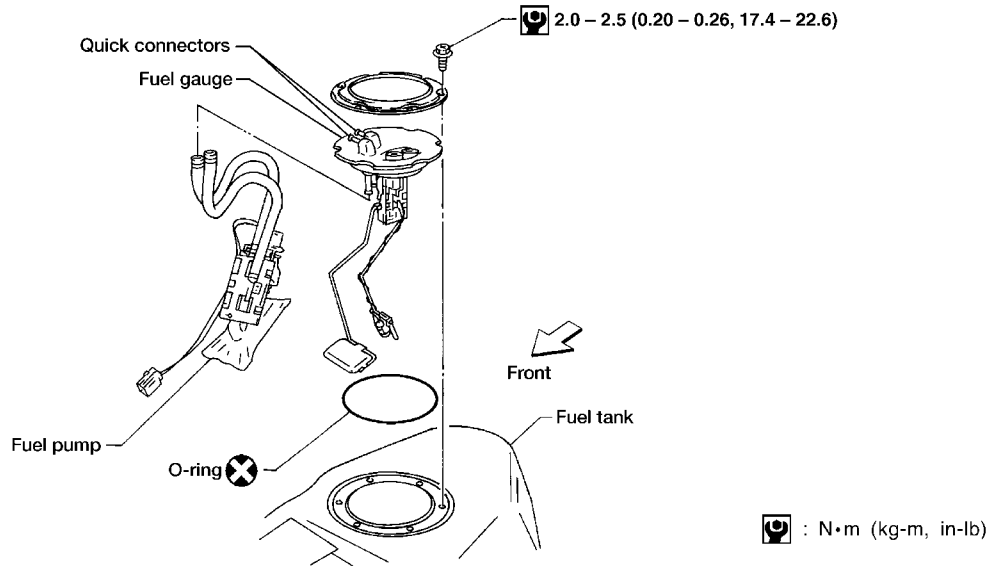

AFE091

GI
MA
EM
LC
EC
FE
CL
MT
AT
TF
PD
FA
RA
BR
ST
RS
BT
HA
EL
IDX

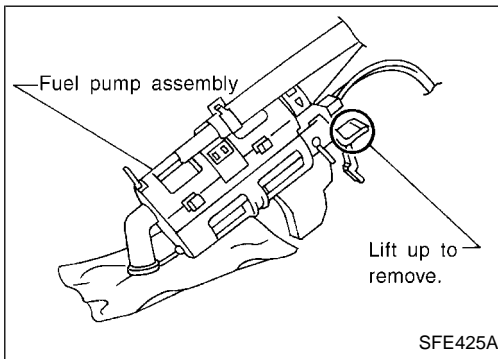

SFE425A

REMOVAL AND INSTALLATION

1. Remove fuel tank. Refer to "Fuel Tank" "REMOVAL," FE-5.
 - For removal of quick connectors, refer to step 6 of "Fuel Tank" "Removal," FE-5.
2. Remove the six screws.
3. Remove fuel gauge retainer and fuel gauge.
4. Remove fuel pump with bracket while lifting the pawl of the fuel pump bracket upward.

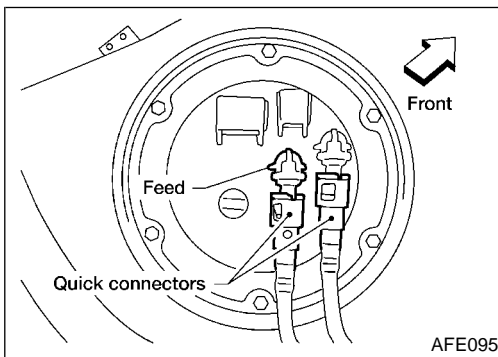

AFE095

5. Installation procedure is the reverse order of removal.
 - Install fuel gauge as shown.

CAUTION:

- **Tighten bolts to specified torque.**
 - :2.0 - 2.5 N·m (0.20 - 0.26 kg - m, 17.4 - 22.6 in - lb)
- Always replace O-ring with a new one.
- After installation, run engine and check for leaks at connections.

EXHAUST SYSTEM

CAUTION:

- Always replace exhaust gaskets with new ones when reassembling.
- With engine running, check all tube connections for exhaust gas leaks, and entire system for unusual noises.
- Check to ensure that mounting brackets and mounting insulators are installed properly and free from undue stress. Improper installation could result in excessive noise or vibration.
- Discard any heated oxygen sensor which has been dropped from a height of more than 0.5 m (19.7 in) onto a hard surface such as a concrete floor; use a new one.
- Before installing new oxygen sensor, clean exhaust system threads using oxygen sensor thread cleaner Tool J-43897-18 or J-43897-12 and approved anti-seize lubricant.
- Do not overtorque the oxygen sensor. Doing so may cause damage to the oxygen sensor, resulting in the MIL coming on.

