

A

SECTION LU

ENGINE LUBRICATION SYSTEM

C

CONTENTS

KA24DE	VG33E and VG33ER
PRECAUTIONS 2	PRECAUTIONS 11
Precautions for Supplemental Restraint System (SRS) "AIR BAG" and "SEAT BELT PRE-TENSIONER" 2	Precautions for Supplemental Restraint System (SRS) "AIR BAG" and "SEAT BELT PRE-TENSIONER" 11
Precautions for Liquid Gasket 2	Precautions for Liquid Gasket 11
REMOVAL OF LIQUID GASKET 2	REMOVAL OF LIQUID GASKET 11
LIQUID GASKET APPLICATION PROCEDURE... 3	LIQUID GASKET APPLICATION PROCEDURE.. 12
PREPARATION 4	PREPARATION 13
Special Service Tools 4	Special Service Tools 13
LUBRICATION SYSTEM 5	LUBRICATION SYSTEM 14
Lubrication Circuit 5	Lubrication Circuit 14
ENGINE OIL 7	ENGINE OIL 15
Oil Pressure Check 7	Oil Pressure Check 15
OIL PUMP 8	OIL PUMP 16
Removal and Installation 8	Removal and Installation 16
Regulator Valve 9	Disassembly and Assembly 16
Oil Filter 9	Inspection 16
Oil Pump Inspection 9	Regulator Valve Inspection 17
SERVICE DATA AND SPECIFICATIONS (SDS) 10	Oil Filter 17
Oil Pressure Check 10	Oil Filter Bracket 18
Regulator Valve 10	REMOVAL AND INSTALLATION 18
Oil Pump 10	SERVICE DATA AND SPECIFICATIONS (SDS) 19
	Oil Pressure Check 19
	Regulator Valve 19
	Oil Pump 19

PRECAUTIONS

PFP:00001

Precautions for Supplemental Restraint System (SRS) “AIR BAG” and “SEAT BELT PRE-TENSIONER”

EBS00GUD

The Supplemental Restraint System such as “AIR BAG” and “SEAT BELT PRE-TENSIONER”, used along with a front seat belt, helps to reduce the risk or severity of injury to the driver and front passenger for certain types of collision. This system may include seat belt switch inputs and dual stage front air bag modules. If equipped with dual stage front air bag modules, the SRS system uses the seat belt switches to determine the front air bag deployment, and may only deploy one front air bag, depending on the severity of a collision and whether the front occupants are belted or unbelted. Information necessary to service the system safely is included in the SRS and SB section of this Service Manual.

The vehicle may be equipped with a passenger air bag deactivation switch. Because no rear seat exists where a rear-facing child restraint can be placed, the switch is designed to turn off the passenger air bag so that a rear-facing child restraint can be used in the front passenger seat. The switch is located in the center of the instrument panel, near the ashtray. When the switch is turned to the ON position, the passenger air bag is enabled and could inflate for certain types of collision. When the switch is turned to the OFF position, the passenger air bag is disabled and will not inflate. A passenger air bag OFF indicator on the instrument panel lights up when the passenger air bag is switched OFF. The driver air bag always remains enabled and is not affected by the passenger air bag deactivation switch.

WARNING:

- To avoid rendering the SRS inoperative, which could increase the risk of personal injury or death in the event of a collision which would result in air bag inflation, all maintenance must be performed by an authorized NISSAN/INFINITI dealer.
- Improper maintenance, including incorrect removal and installation of the SRS, can lead to personal injury caused by unintentional activation of the system. For removal of Spiral Cable and Air Bag Module, see the SRS section.
- Do not use electrical test equipment on any circuit related to the SRS unless instructed to in this Service Manual. SRS wiring harnesses can be identified by yellow and/or orange harnesses or harness connectors.
- The vehicle may be equipped with a passenger air bag deactivation switch which can be operated by the customer. When the passenger air bag is switched OFF, the passenger air bag is disabled and will not inflate. When the passenger air bag is switched ON, the passenger air bag is enabled and could inflate for certain types of collision. After SRS maintenance or repair, make sure the passenger air bag deactivation switch is in the same position (ON or OFF) as when the vehicle arrived for service.

Precautions for Liquid Gasket REMOVAL OF LIQUID GASKET

EBS00GUE

- After removing the mounting bolts and nuts, separate the mating surface using a seal cutter and remove the sealant.

CAUTION:

Be careful not to damage the mating surfaces.

- In areas where the cutter is difficult to use, use a plastic hammer to lightly tap the areas where the sealant is applied.

CAUTION:

If for some unavoidable reason a tool such as a flat-bladed screwdriver is used, be careful not to damage the mating surfaces.

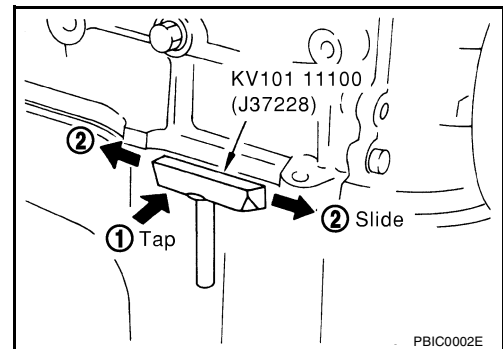

PBIC0002E

PRECAUTIONS

[KA24DE]

LIQUID GASKET APPLICATION PROCEDURE

1. Using a scraper, remove the old sealant adhering to the mating surface.
 - Remove the sealant completely from the groove, mounting bolts, and bolt holes.
2. Clean the mating surface thoroughly to remove adhering moisture, grease and foreign materials.
3. Install the sealant tube into the tube presser.
Use Genuine Silicone RTV or equivalent. Refer to [GI-42, "Recommended Chemical Products and Sealants"](#) .

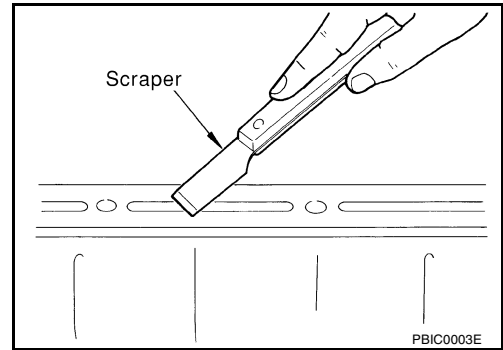

4. Apply the sealant without breaks to the specified area with the specified dimensions.
 - If there is a groove for the sealant application, apply the sealant to the groove.

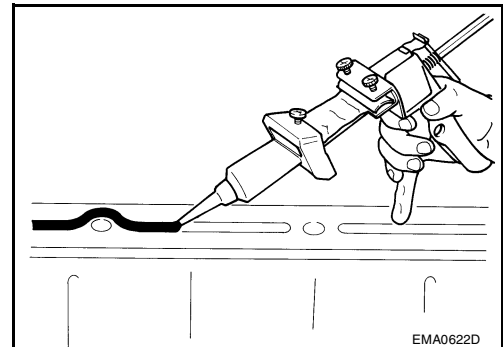

- As for the bolt holes, normally apply the sealant inside the holes. If specified, it should be applied outside the holes. Make sure to read the instructions in this manual.
- Within five minutes of sealant application, install the mating component.
- If the sealant protrudes, wipe it off immediately.
- Do not retighten after the installation.
- After 30 minutes or more have passed from the installation, fill the engine with the correct oil and coolant. Refer to [MA-12, "Recommended Fluids and Lubricants"](#) .

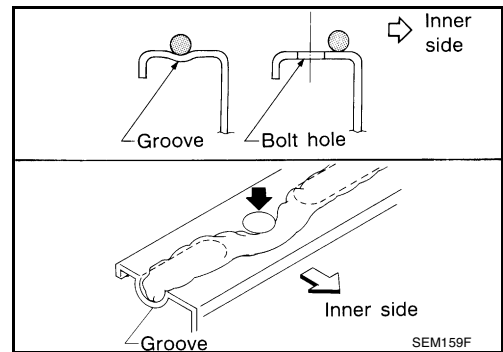

CAUTION:

If there are specific instructions in the service manual, observe them.

PREPARATION

Special Service Tools

The actual shapes of Kent-Moore tools may differ from those of special service tools illustrated here.

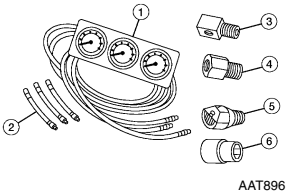
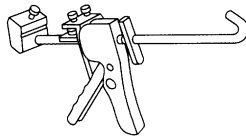
Tool number (Kent-Moore No.) Tool name	Description
(J34301-C) Oil pressure gauge set 1: (J34301-1) Oil pressure gauge 2: (J34301-2) Hoses 3: (J34298) Adapter 4: (J34282-1) Adapter 5: (790-301-1230-A) 60° adapter 6: (J34301-15) Square socket	 Measuring oil pressure Maximum measuring range: 1,379 kPa (14 kg/cm² , 200 psi)
WS39930000 (—) Tube presser	 Pressing the tube of liquid gasket

LUBRICATION SYSTEM

Lubrication Circuit

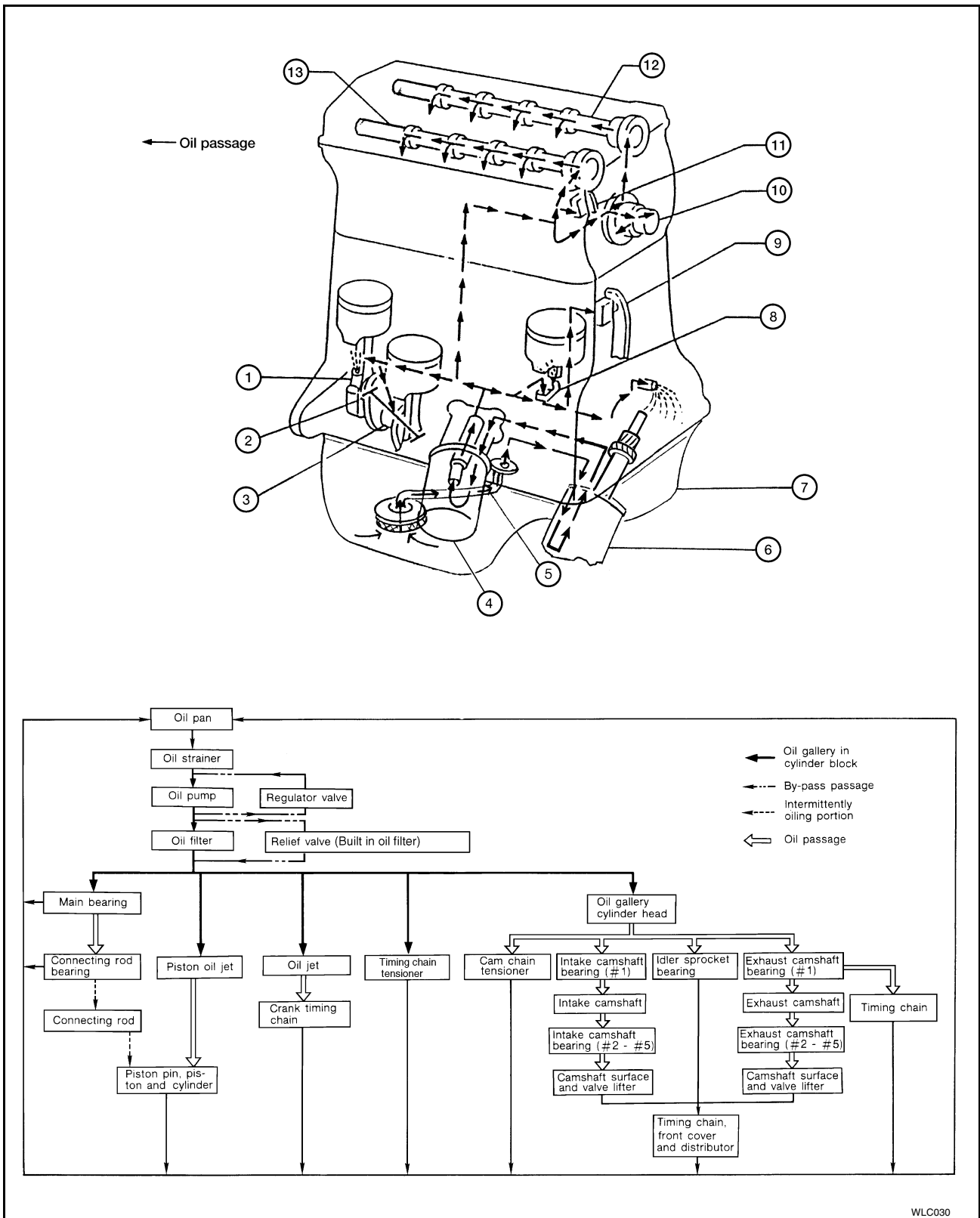

- | | | |
|-------------------|---------------------------|---------------------------|
| 1. Connecting rod | 2. Connecting rod bearing | 3. Main bearing |
| 4. Oil filter | 5. Oil strainer | 6. Oil pump |
| 7. Oil pan | 8. Piston oil jet | 9. Timing chain tensioner |

LUBRICATION SYSTEM

[KA24DE]

-
- 10. Idler sprocket
 - 13. Intake camshaft

- 11. Upper timing chain tensioner

- 12. Exhaust camshaft

ENGINE OIL

Oil Pressure Check

WARNING:

- Be careful not to burn yourself, as the engine and oil may be hot.
- For M/T models, put shift lever in Neutral “N” position. For A/T models, put selector lever in Park “P” position.

1. Check oil level.
2. Remove oil pressure switch.
3. Install pressure gauge.
4. Start engine and warm it up to normal operating temperature.
5. Check oil pressure with engine running under no-load at idle speed and at 3,000 rpm.

Engine oil pressure [oil temperature at 80°C (148°F)]

Engine speed rpm	Approximate discharge pressure kPa (kg/cm ² , psi)
Idle speed	More than 78 (0.8, 11)
3,000	412 - 481 (4.2 - 4.9, 60 - 70)

- If difference is extreme, check oil passage and oil pump for oil leaks.
6. Install oil pressure switch with thread sealant. Refer to [GI-42](#).
"RECOMMENDED CHEMICAL PRODUCTS AND SEALANTS"

Oil pressure switch : 12.25 – 17.15 N-m (1.3 – 1.7 kg-m, 9 – 12 ft-lb)

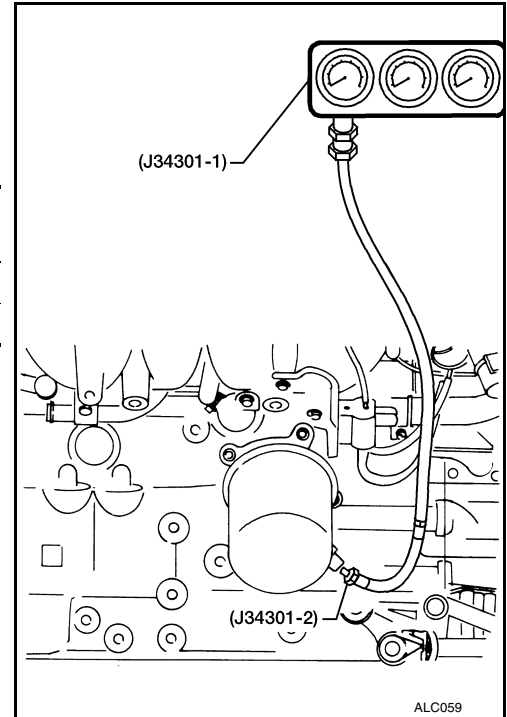

A
LU
C
D
E
F
G
H
I
J
K
L
M

OIL PUMP

Removal and Installation

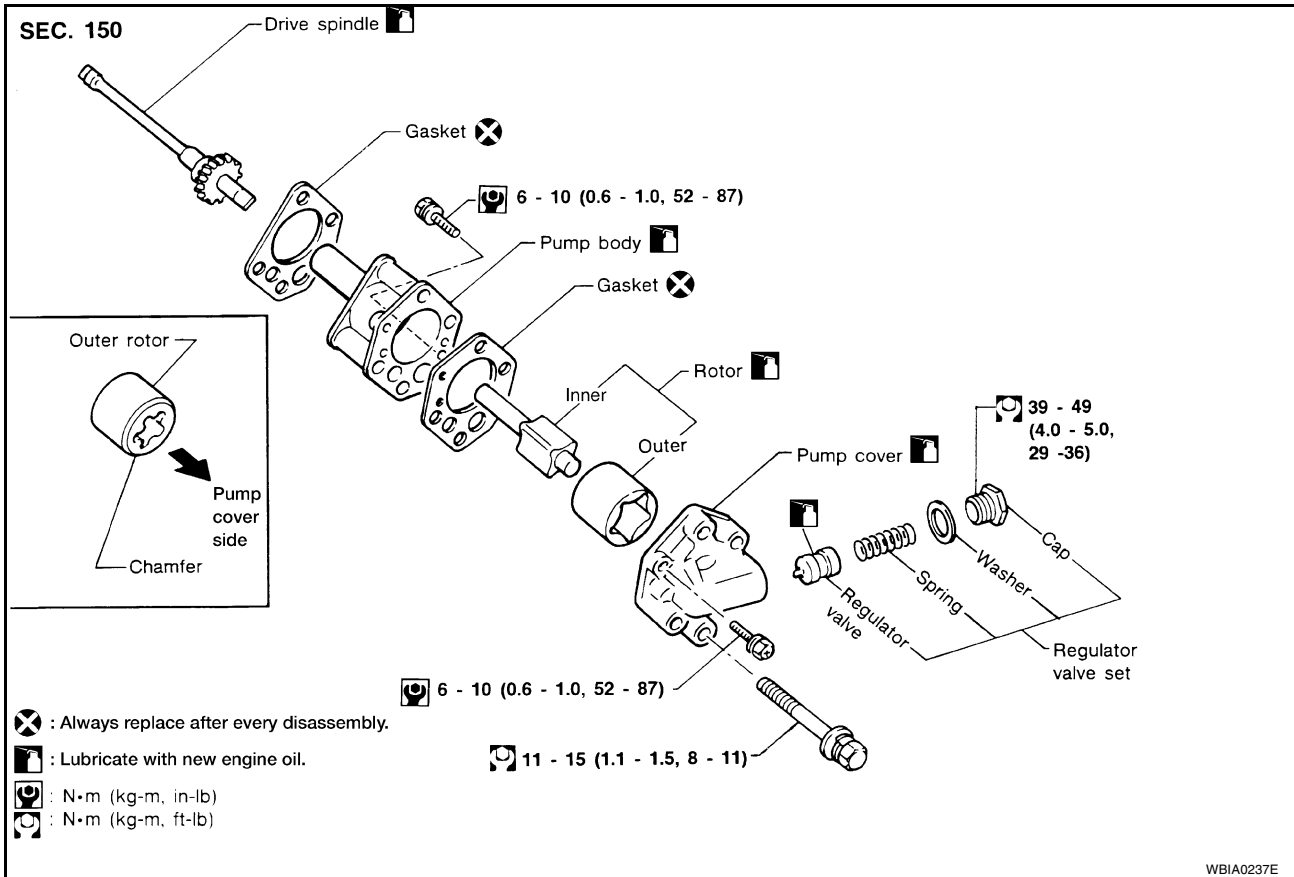

- Remove oil pump mounting bolts, then withdraw oil pump from engine.
 - When removing oil pump, turn crankshaft so that No. 1 piston is at TDC on its compression stroke.

CAUTION:

Be careful not to damage drive spindle when withdrawing oil pump from engine.

- Installation is in the reverse order of removal.
 - Always replace with new oil seal and gasket.
 - When installing oil pump, apply engine oil to gears, then align punch mark on drive spindle and oil hole on oil pump.

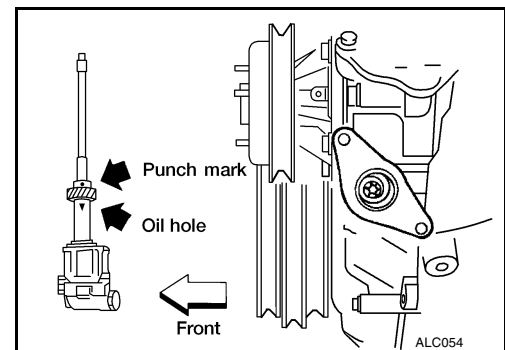

EBS00GUJ

Regulator Valve

1. Visually inspect components for wear and damage.
2. Check oil pressure regulator valve sliding surface and spring.
3. Coat regulator valve with engine oil. Check that it falls smoothly into the valve hole by its own weight.
4. Replace regulator valve set or oil pump assembly, if damaged.

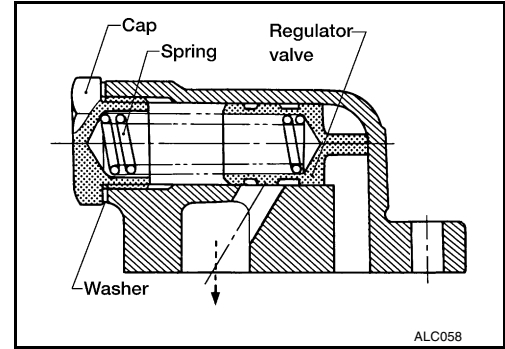

Oil Filter

The oil filter is a small, full-flow cartridge type and is provided with a relief valve.

- When changing oil filter, refer to [MA-21, "Changing Oil Filter"](#).

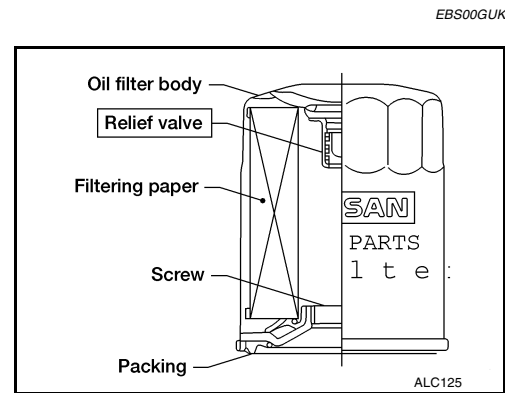

Oil Pump Inspection

Using a feeler gauge, check the following clearances after the pump is disassembled.

Standard clearance:

Unit: mm (in)

Inner rotor tip clearance (1)	less than 0.12 (0.0047)
Outer rotor to pump body clearance (2)	0.15 - 0.21 (0.0059 - 0.0083)
Side clearance (with gasket) (3)	0.04 - 0.100 (0.0016 - 0.0039)

- If the inner rotor tip clearance (1) exceeds the limit, replace rotor set.
- If pump body to outer rotor clearance and side clearance (2) or (3) exceed the specification, replace oil pump assembly.

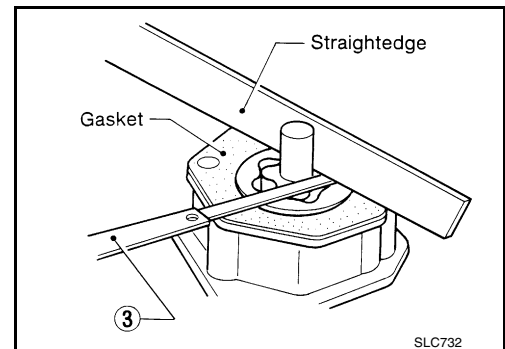
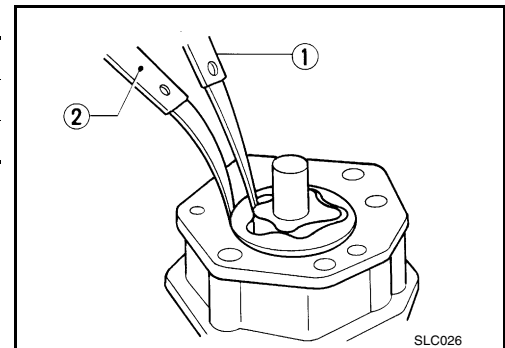

SERVICE DATA AND SPECIFICATIONS (SDS)

[KA24DE]

SERVICE DATA AND SPECIFICATIONS (SDS)

PF0:00030

Oil Pressure Check

EBS00GUM

Engine speed	Approximate discharge pressure kPa (kg/cm ² , psi)
Idle speed	More than 78 (0.8, 11)
3,000 rpm	412 - 481 (4.2 - 4.9, 60 - 70)

Regulator Valve

EBS00GUN

Unit: mm (in)

Regulator valve to oil pump cover clearance	0.040 - 0.097 (0.0016 - 0.0038)
---	---------------------------------

Oil Pump

EBS00GUO

Unit: mm (in)

Inner rotor tip clearance	Less than 0.12 (0.0047)
Outer rotor to pump body clearance	0.15 - 0.21 (0.0059 - 0.0083)
Side clearance (with gasket)	0.04 - 0.100 (0.0016 - 0.0039)

PRECAUTIONS

PF0:00001

Precautions for Supplemental Restraint System (SRS) “AIR BAG” and “SEAT BELT PRE-TENSIONER”

EBS00GUP

The Supplemental Restraint System such as “AIR BAG” and “SEAT BELT PRE-TENSIONER”, used along with a front seat belt, helps to reduce the risk or severity of injury to the driver and front passenger for certain types of collision. This system may include seat belt switch inputs and dual stage front air bag modules. If equipped with dual stage front air bag modules, the SRS system uses the seat belt switches to determine the front air bag deployment, and may only deploy one front air bag, depending on the severity of a collision and whether the front occupants are belted or unbelted. Information necessary to service the system safely is included in the SRS and SB section of this Service Manual.

The vehicle may be equipped with a passenger air bag deactivation switch. Because no rear seat exists where a rear-facing child restraint can be placed, the switch is designed to turn off the passenger air bag so that a rear-facing child restraint can be used in the front passenger seat. The switch is located in the center of the instrument panel, near the ashtray. When the switch is turned to the ON position, the passenger air bag is enabled and could inflate for certain types of collision. When the switch is turned to the OFF position, the passenger air bag is disabled and will not inflate. A passenger air bag OFF indicator on the instrument panel lights up when the passenger air bag is switched OFF. The driver air bag always remains enabled and is not affected by the passenger air bag deactivation switch.

WARNING:

- To avoid rendering the SRS inoperative, which could increase the risk of personal injury or death in the event of a collision which would result in air bag inflation, all maintenance must be performed by an authorized NISSAN/INFINITI dealer.
- Improper maintenance, including incorrect removal and installation of the SRS, can lead to personal injury caused by unintentional activation of the system. For removal of Spiral Cable and Air Bag Module, see the SRS section.
- Do not use electrical test equipment on any circuit related to the SRS unless instructed to in this Service Manual. SRS wiring harnesses can be identified by yellow and/or orange harnesses or harness connectors.
- The vehicle may be equipped with a passenger air bag deactivation switch which can be operated by the customer. When the passenger air bag is switched OFF, the passenger air bag is disabled and will not inflate. When the passenger air bag is switched ON, the passenger air bag is enabled and could inflate for certain types of collision. After SRS maintenance or repair, make sure the passenger air bag deactivation switch is in the same position (ON or OFF) as when the vehicle arrived for service.

**Precautions for Liquid Gasket
REMOVAL OF LIQUID GASKET**

EBS00GUQ

- After removing the mounting bolts and nuts, separate the mating surface using a seal cutter and remove the sealant.

CAUTION:

Be careful not to damage the mating surfaces.

- In areas where the cutter is difficult to use, use a plastic hammer to lightly tap the areas where the sealant is applied.

CAUTION:

If for some unavoidable reason a tool such as a flat-bladed screwdriver is used, be careful not to damage the mating surfaces.

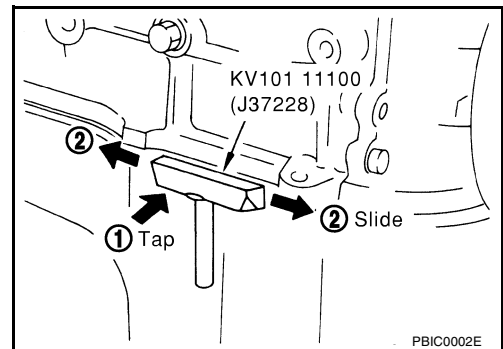

PRECAUTIONS

[VG33E and VG33ER]

LIQUID GASKET APPLICATION PROCEDURE

1. Using a scraper, remove the old sealant adhering to the mating surface.
 - Remove the sealant completely from the groove, mounting bolts, and bolt holes.
2. Clean the mating surface thoroughly to remove adhering moisture, grease and foreign materials.
3. Install the sealant tube into the tube presser.
Use Genuine Silicone RTV or equivalent. Refer to [GI-42](#), "[RECOMMENDED CHEMICAL PRODUCTS AND SEALANTS](#)".

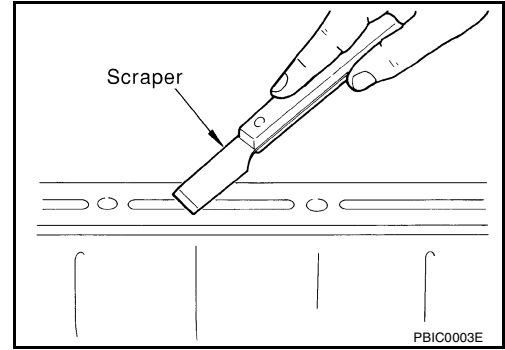

4. Apply the sealant without breaks to the specified area with the specified dimensions.
 - If there is a groove for the sealant application, apply the sealant to the groove.

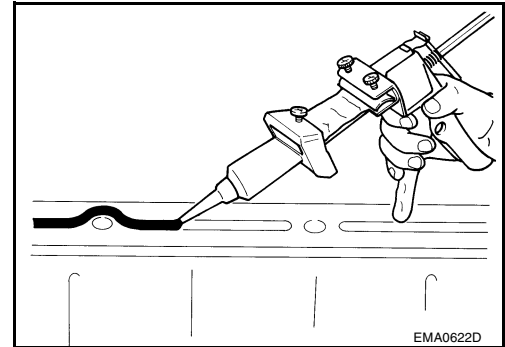

- As for the bolt holes, normally apply the sealant inside the holes. If specified, it should be applied outside the holes. Make sure to read the instructions in this manual.
- Within five minutes of sealant application, install the mating component.
- If the sealant protrudes, wipe it off immediately.
- Do not retighten after the installation.
- After 30 minutes or more have passed from the installation, fill the engine with the correct oil and coolant. Refer to [MA-12](#), "[Recommended Fluids and Lubricants](#)".

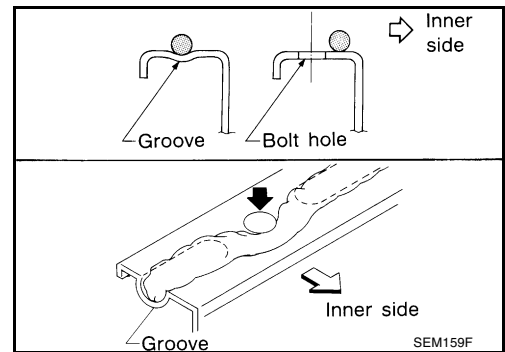

CAUTION:

If there are specific instructions in the service manual, observe them.

PREPARATION

[VG33E and VG33ER]

PREPARATION

PF0:00002

Special Service Tools

EBS00GUR

The actual shapes of Kent-Moore tools may differ from those of special service tools illustrated here.

Tool number (Kent-Moore No.) Tool name	Description
ST25051001 (J25695-1) Oil pressure gauge	Measuring oil pressure Maximum measuring range: 2,452 kPa (25 kg/cm² , 356 psi)
ST25052000 (J25695-2) Hose	Adapting oil pressure gauge to cylinder block
WS39930000 (—) Tube presser	Pressing the tube of liquid gasket

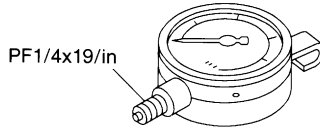

NT558

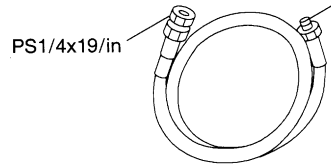

NT559

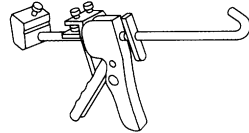

NT052

A
LU
C
D
E
F
G
H
I
J
K
L
M

LUBRICATION SYSTEM

Lubrication Circuit

EBS00GUS

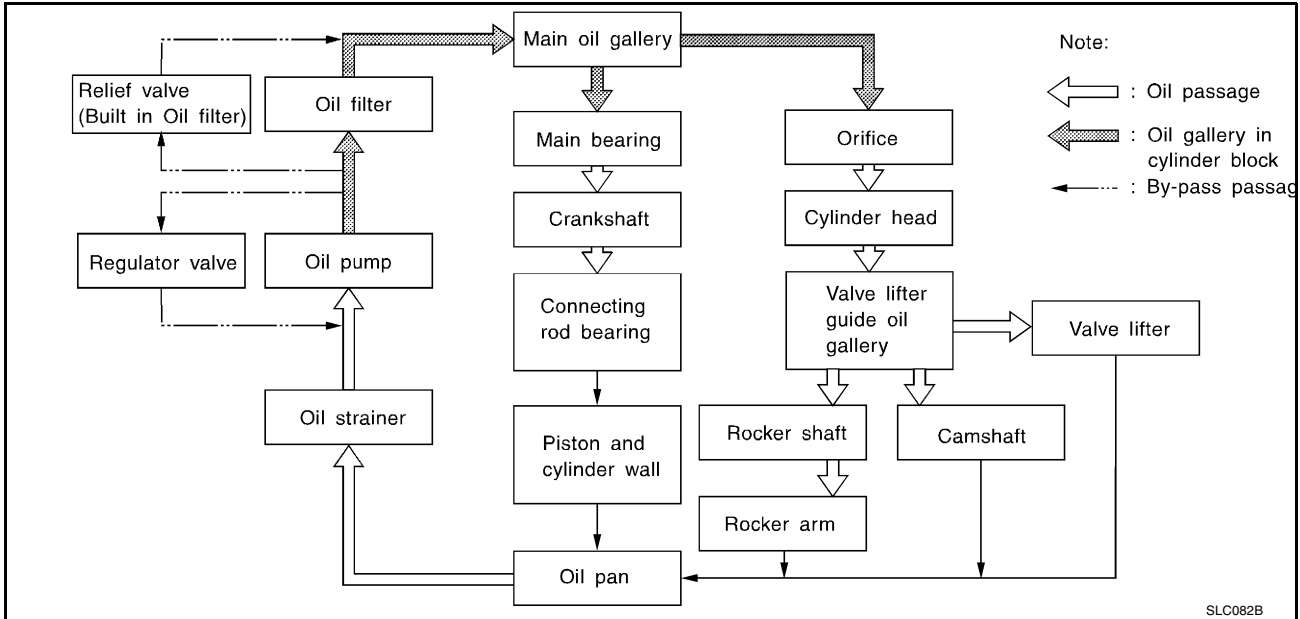

ENGINE OIL

Oil Pressure Check

WARNING:

- Be careful not to burn yourself, as the engine and oil may be hot.
 - Oil pressure check should be done in “Neutral position” (M/T) or “Parking position” (A/T).
1. Check oil level.
 2. Remove oil pressure switch.

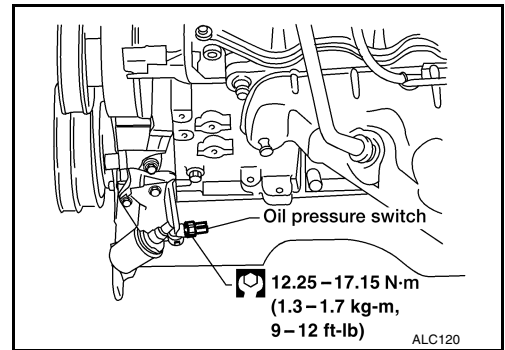

3. Install pressure gauge.
4. Start engine and warm it up to normal operating temperature.
5. Check oil pressure with engine running under no-load at idle speed and at 2,000 rpm.

Engine oil pressure [oil temperature at 80°C (148°F)]

Engine speed rpm	Approximate discharge pressure kPa (kg/cm ² , psi)
Idle speed	More than 59 (0.6, 9)
2,000	412 - 451 (4.2 - 4.6, 60 - 65)

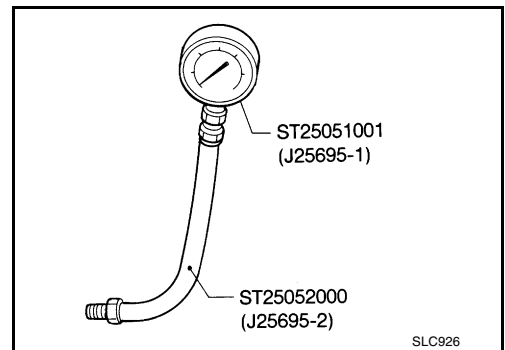

- If difference is extreme, check oil passage and oil pump for oil leaks.
6. Install oil pressure switch with sealant. Refer to [GI-42, "RECOMMENDED CHEMICAL PRODUCTS AND SEALANTS"](#) .

Oil pressure switch : 12.25 – 17.15 N·m (1.3 – 1.7 kg-m, 9 – 12 ft-lb)

OIL PUMP

PFP:15010

Removal and Installation

EBS00GUU

1. Drain engine oil. Refer [MA-30, "Changing Engine Oil"](#) .
2. Drain engine coolant from drain plug on radiator. Refer to [MA-26, "Changing Engine Coolant"](#) .
3. Remove air duct (from mass air flow sensor to throttle body).
4. Remove cooling fan. Refer to [CO-32, "COOLING FAN \(CRANKSHAFT DRIVEN\)"](#) .
5. Remove radiator hoses (upper and lower) and fan shroud. Refer to [CO-30, "RADIATOR"](#) .
6. Remove drive belts. Refer to [MA-24, "Checking Drive Belts"](#) .
7. Remove crankshaft pulley and front upper and lower belt covers. Refer to [EM-91, "TIMING BELT"](#) .
8. Remove oil pan. Refer to [EM-88, "OIL PAN"](#) .
9. Remove oil strainer.
10. Remove oil pump assembly.
11. Installation is in the reverse order of removal.

Disassembly and Assembly

EBS00GUU

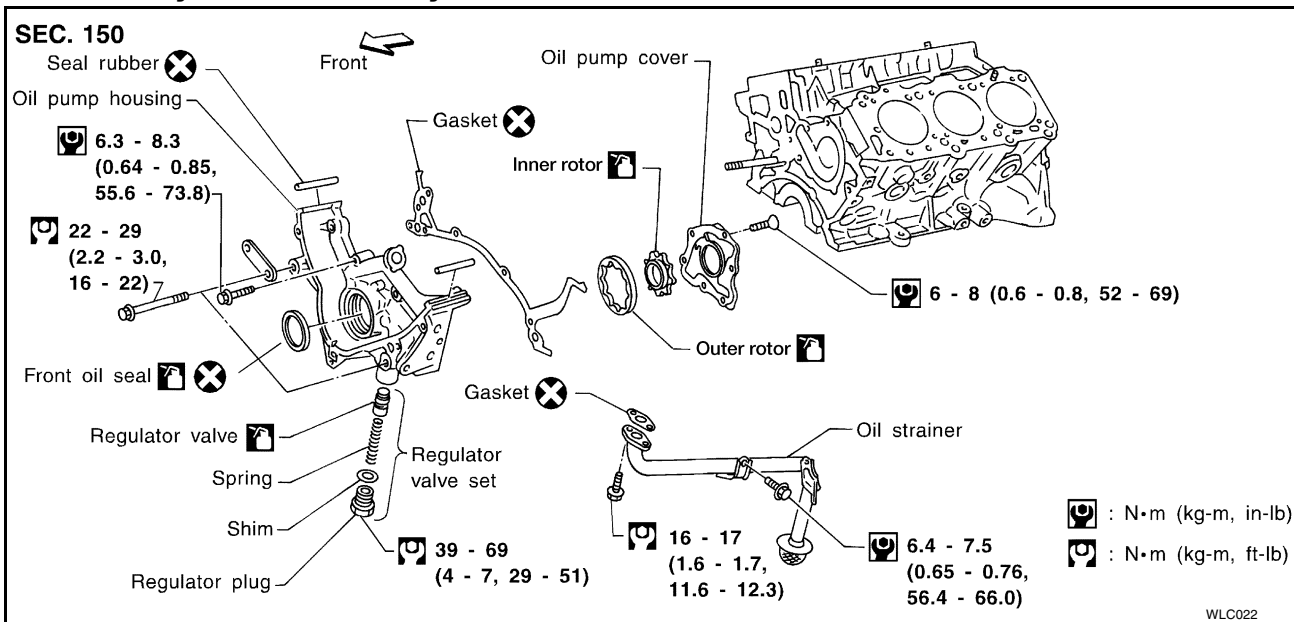

- Always replace with new oil seal and gasket.
- When installing oil pump, apply engine oil to inner and outer rotors.
- Be sure that O-ring is properly installed.

Inspection

EBS00GUU

Using a feeler gauge, straightedge and micrometers, check all of the following clearances:

Unit: mm (in)

Oil pump housing to outer rotor radial clearance 1	0.114 - 0.200 (0.0045 - 0.0079)
Inner rotor to outer rotor tip clearance 2	Below 0.18 (0.0071)
Oil pump housing to inner rotor axial clearance 3	0.05 - 0.09 (0.0020 - 0.0035)
Oil pump housing to outer rotor axial clearance 4	0.050 - 0.110 (0.0020 - 0.0043)
Inner rotor brazed portion to housing clearance 5	0.045 - 0.091 (0.0018 - 0.0036)

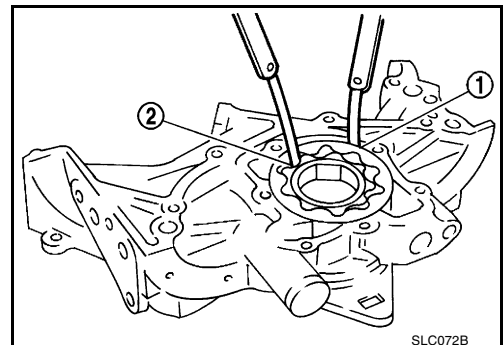

- If the tip clearance (2) exceeds the limit, replace rotor set.

OIL PUMP

[VG33E and VG33ER]

- If body to rotor clearances (1, 3, 4, 5) exceed the limit, replace oil pump body assembly.

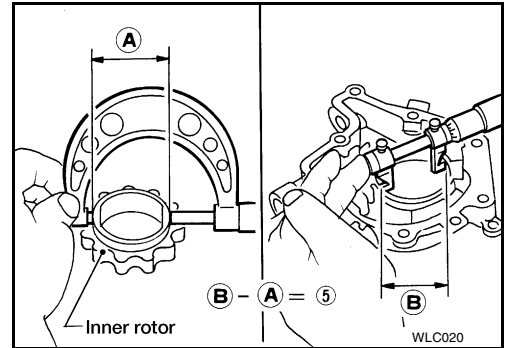
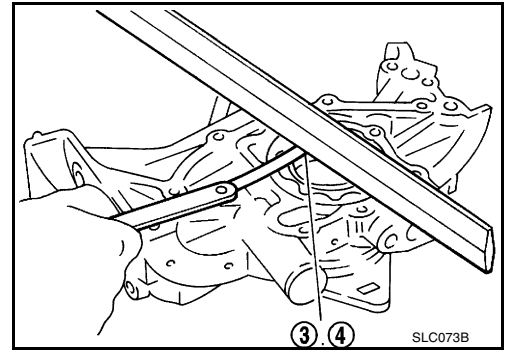

Regulator Valve Inspection

1. Visually inspect components for wear and damage.
2. Check oil pressure regulator valve sliding surface and valve spring.
3. Coat regulator valve with engine oil. Check that it falls smoothly into the valve hole by its own weight.
4. If damaged, replace regulator valve set or oil pump assembly.

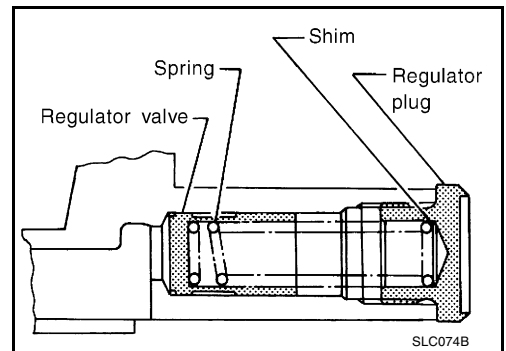

Oil Filter

The oil filter is a small, full-flow cartridge type and is provided with a relief valve.

- When changing oil filter. Refer to [MA-31, "Changing Oil Filter"](#).

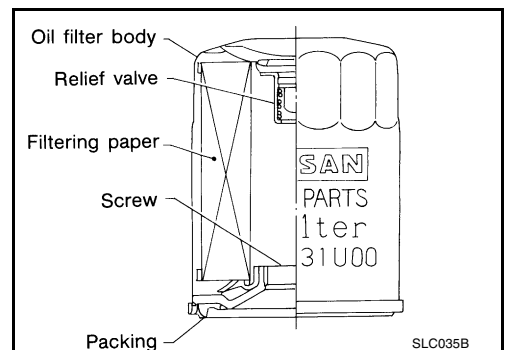

Oil Filter Bracket REMOVAL AND INSTALLATION

1. Remove oil filter. Refer to [MA-31, "Changing Oil Filter"](#) .
2. Disconnect oil pressure switch connector.
3. Remove oil filter bracket.
4. Installation is in the reverse order of removal.

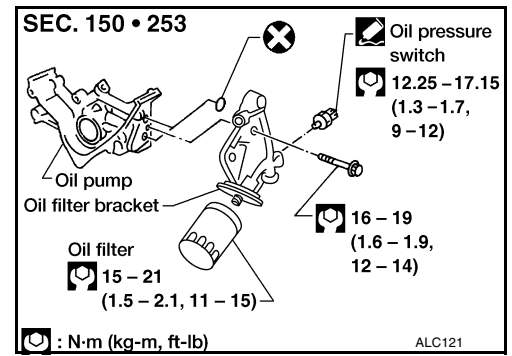

SERVICE DATA AND SPECIFICATIONS (SDS)

[VG33E and VG33ER]

SERVICE DATA AND SPECIFICATIONS (SDS)

PFP:00030

Oil Pressure Check

EBS00GV0

Engine speed rpm	Approximate discharge pressure kPa (kg/cm ² , psi)
Idle speed	More than 59 (0.6, 9)
2,000	412 - 451 (4.2 - 4.6, 60 - 65)

Regulator Valve

EBS00GV1

Unit: mm (in)

Regulator valve to oil pump cover clearance	0.040 - 0.097 (0.0016 - 0.0038)
---	---------------------------------

Oil Pump

EBS00GV2

Unit: mm (in)

Oil pump housing to outer rotor radial clearance	0.114 - 0.200 (0.0045 - 0.0079)
Inner rotor to outer rotor tip clearance	Below 0.18 (0.0071)
Oil pump housing to inner rotor axial clearance	0.05 - 0.09 (0.0020 - 0.0035)
Oil pump housing to outer rotor axial clearance	0.050 - 0.110 (0.0020 - 0.0043)
Inner rotor to brazed portion of housing clearance	0.045 - 0.091 (0.0018 - 0.0036)

A
LU
C
D
E
F
G
H
I
J
K
L
M

SERVICE DATA AND SPECIFICATIONS (SDS)

[VG33E and VG33ER]
