

SECTION **FAX**  
FRONT AXLE

A  
B  
C

FAX

CONTENTS

E

<b>PRECAUTIONS</b> .....	2	<b>DRIVE SHAFT</b> .....	7	F
Precautions .....	2	Removal and Installation .....	7	
<b>PREPARATION</b> .....	3	REMOVAL .....	7	
Special Service Tools .....	3	INSPECTION AFTER REMOVAL .....	7	G
Commercial Service Tools .....	3	INSTALLATION .....	8	
<b>NOISE, VIBRATION, AND HARSHNESS (NVH)</b>		Disassembly and Assembly .....	8	H
<b>TROUBLESHOOTING</b> .....	4	DISASSEMBLY .....	8	
NVH Troubleshooting Chart .....	4	INSPECTION AFTER DISASSEMBLY .....	9	
<b>WHEEL HUB</b> .....	5	ASSEMBLY .....	10	
On-Vehicle Inspection and Service .....	5	<b>SERVICE DATA AND SPECIFICATIONS (SDS)</b> .....	14	I
WHEEL BEARING INSPECTION .....	5	Wheel Bearing .....	14	
Removal and Installation .....	5	Drive Shaft .....	14	
REMOVAL .....	5			J
INSPECTION AFTER REMOVAL .....	6			
INSTALLATION .....	6			K

J

K

L

M

# PRECAUTIONS

---

## PRECAUTIONS

PF0:00001

### Precautions

EDS0024C

Observe the following precautions when disassembling and servicing the wheel hub and drive shafts.

- Perform work in a location which is as dust-free as possible.
- Before disassembling and servicing, clean the outside of parts.
- Prevention of the entry of foreign objects must be taken into account during disassembly of the component parts.
- Disassembled parts must be carefully reassembled in the correct order. If work is interrupted, a clean cover must be placed over parts.
- Paper shop cloths must be used. Fabric shop cloths must not be used because of the danger of lint adhering to parts.
- Disassembled parts (except for rubber parts) should be cleaned with a suitable solvent which shall be removed by blowing with air or wiping with paper shop cloths.

# PREPARATION

## PREPARATION

PF0:00002

### Special Service Tools

EDS0024D

The actual shapes of Kent-Moore tools may differ from those of special service tools illustrated here.

Tool number (Kent-Moore No.) Tool name	Description
ST29020001 (J-24319-01) Gear arm puller	Removing ball joint for steering knuckle <b>a: 34 mm (1.34 in)</b> <b>b: 6.5 mm (0.256 in)</b> <b>c: 61.5 mm (2.421 in)</b>
KV38105500 (J-33904) Protector	Installing drive shaft <b>a: 32 mm (1.26 in) dia</b>
KV40107300 ( — ) Boot Band crimping tool	Installing boot bands

A  
B  
C  
FAX  
E  
F  
G  
H  
I  
J  
K  
L  
M

## Commercial Service Tools

EDS0024E

Tool name	Description
Power tools	Removing bolts and nuts

# NOISE, VIBRATION, AND HARSHNESS (NVH) TROUBLESHOOTING

## NOISE, VIBRATION, AND HARSHNESS (NVH) TROUBLESHOOTING

PF0:00003

### NVH Troubleshooting Chart

EDS0024F

Use the chart below to help you find the cause of the symptom. If necessary, repair or replace these parts.

Reference page		<a href="#">FAX-7</a>	<a href="#">FAX-7</a>	<a href="#">FAX-7</a>	<a href="#">FAX-7</a>	<a href="#">FAX-7</a>	<a href="#">FAX-5</a>	<a href="#">PR-3, "NVH Troubleshooting Chart"</a>	<a href="#">FFD-6, "NVH Troubleshooting Chart"</a>	<a href="#">FSU-4, "NVH Troubleshooting Chart"</a>	<a href="#">WT-3, "NVH Troubleshooting Chart"</a>	<a href="#">WT-3, "NVH Troubleshooting Chart"</a>	<a href="#">BR-5, "NVH Troubleshooting Chart"</a>	<a href="#">PS-5, "NVH Troubleshooting Chart"</a>
Possible cause and SUSPECTED PARTS		Excessive joint angle	Joint sliding resistance	Imbalance	Improper installation, looseness	Parts interference	Wheel bearing damage	PROPELLER SHAFT	FRONT FINAL DRIVE	SUSPENSION	TIRES	ROAD WHEEL	BRAKES	STEERING
Symptom	Noise	x	x		x	x	x	x	x	x	x	x	x	x
	Shake	x		x	x	x		x		x	x	x	x	x
	Vibration	x	x	x	x	x	x			x	x			x
	Shimmy	x			x	x				x	x	x	x	x
	Shudder	x	x	x	x					x	x	x	x	x
	Poor quality ride or handling				x	x	x			x	x	x		

x: Applicable

# WHEEL HUB

PFP:43202

## WHEEL HUB

### On-Vehicle Inspection and Service

EDS0024G

Make sure the mounting conditions (looseness, backlash) of each component and component status (wear, damage) are normal.

### WHEEL BEARING INSPECTION

- Move wheel hub in the axial direction by hand. Make sure there is no looseness of wheel bearing.

**Axial end play limit : 0.05 mm (0.0020 in) or less**

- Rotate wheel hub and make sure there is no unusual noise or other irregular conditions. If there are any irregular conditions, replace wheel hub and bearing assembly.

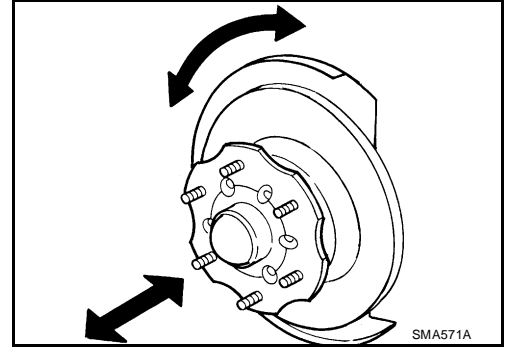

### Removal and Installation

EDS0024H

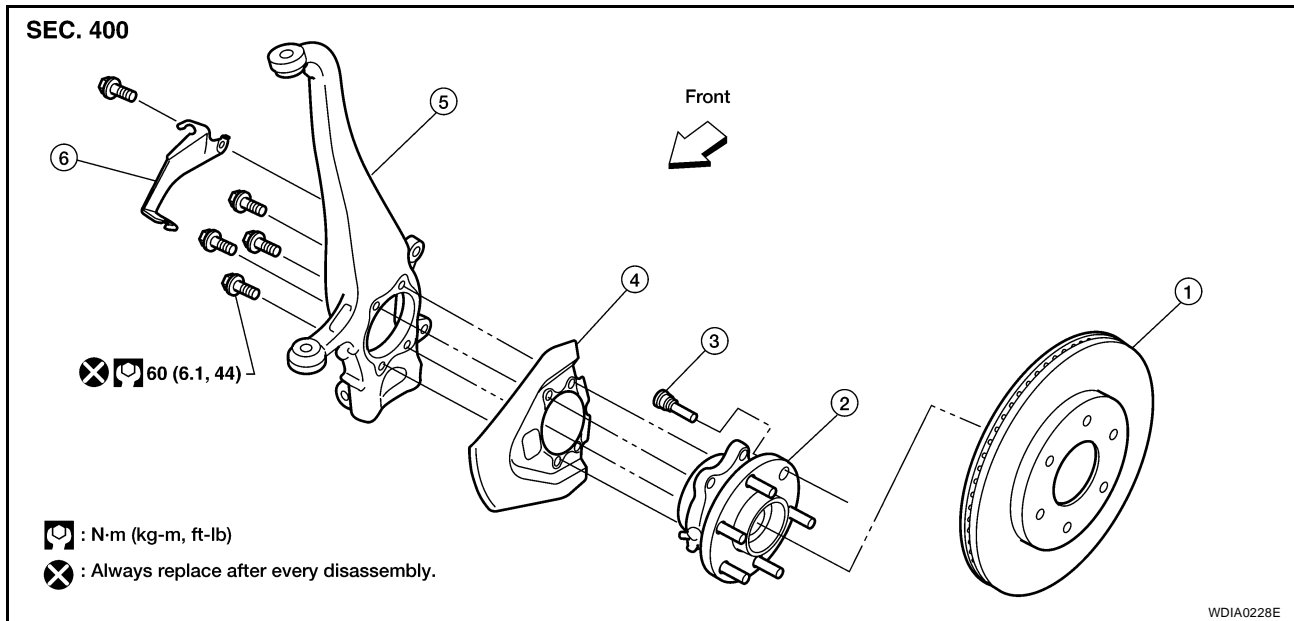

1. Disc rotor
2. Wheel hub and bearing assembly
3. Wheel stud
4. Splash guard
5. Steering knuckle
6. Wheel sensor bracket

### REMOVAL

1. Remove wheel and tire using power tool.
2. Without disassembling the hydraulic lines, remove caliper torque member bolts using power tool. Then reposition brake caliper aside with wire. Refer to [BR-23, "Removal and Installation of Brake Caliper Assembly and Disc Rotor"](#).

#### CAUTION:

Do not press brake pedal while brake caliper is removed.

# WHEEL HUB

- Put alignment mark on disc rotor and wheel hub and bearing assembly, then remove disc rotor.

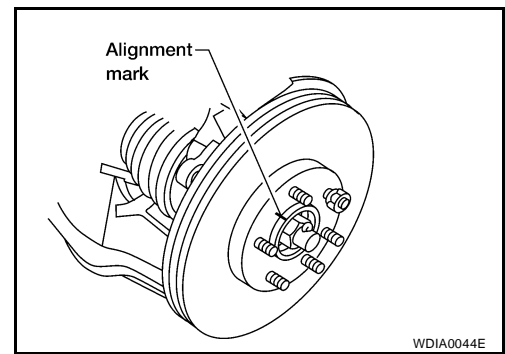

- Remove cotter pin, then remove lock nut from drive shaft using power tool. Refer to [FAX-7, "Removal and Installation"](#) .
  - Remove drive shaft from wheel hub and bearing assembly. Refer to [FAX-5, "Removal and Installation"](#) .
  - Remove wheel sensor from wheel hub and bearing assembly. Refer to [BRC-38, "Removal and Installation"](#) .
    - Inspect the wheel sensor O-ring, replace the wheel sensor assembly if damaged.
    - Clean the wheel sensor hole and mounting surface with a suitable brake cleaner and clean lint-free shop rag. Be careful that dirt and debris does not enter the axle bearing area.
    - Apply a coat of suitable grease to the wheel sensor O-ring and mounting hole.
- CAUTION:**  
**Do not pull on the wheel sensor harness.**
- Remove wheel hub and bearing assembly bolts using power tool.
  - Remove splash guard and wheel hub and bearing assembly from steering knuckle.
    - Carefully remove wheel sensor and harness through hole in splash guard.

## INSPECTION AFTER REMOVAL

Check for deformity, cracks and damage on each part and replace if necessary.

## INSTALLATION

Installation is in the reverse order of removal.

- Use new bolts when installing the wheel hub and bearing assembly.
- When installing disc rotor on wheel hub and bearing assembly, position the disc rotor according to alignment mark. (When not using the alignment mark, refer to [BR-23, "Removal and Installation of Brake Caliper Assembly and Disc Rotor"](#) .)
- When installing wheel and tire, refer to [WT-6, "Rotation"](#) .

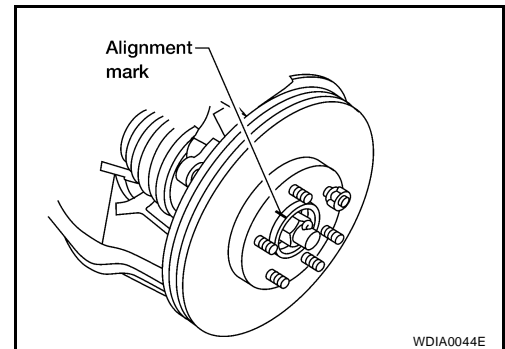

# DRIVE SHAFT

PF0:39100

## DRIVE SHAFT

### Removal and Installation

EDS0024I

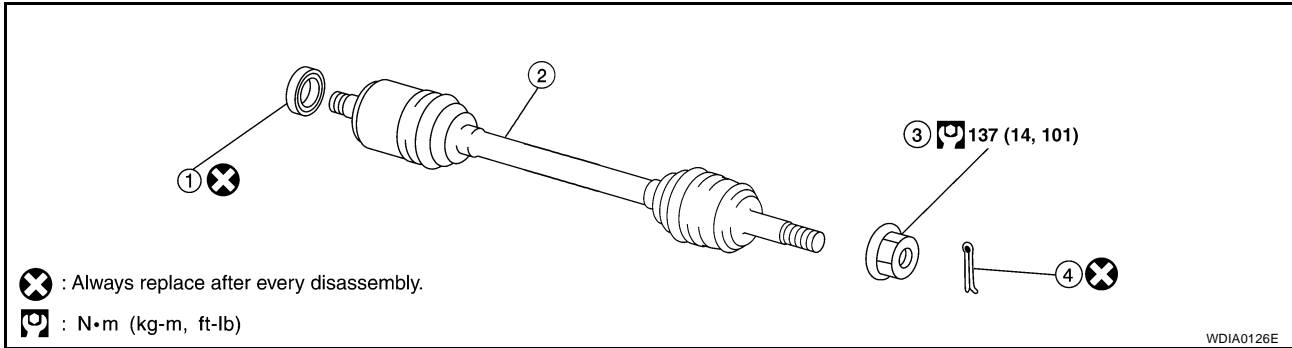

1. Differential side oil seal
2. Drive shaft
3. Drive shaft nut
4. Cotter pin

### REMOVAL

1. Remove wheel and tire using power tool.
2. Remove rear engine under cover using power tool.
3. Remove wheel sensor harness from mount on knuckle, then disconnect wheel sensor harness connector.

#### CAUTION:

**Do not pull on wheel sensor harness.**

4. Remove wheel hub and bearing assembly. Refer to [FAX-5, "Removal and Installation"](#).
  - It is not necessary to remove wheel sensor from wheel hub when wheel hub is not being replaced.
  - Carefully feed wheel sensor harness through hole in splash shield.
5. Separate upper link ball joint stud from steering knuckle using Tool.
  - Support lower link with jack.

**Tool number : ST29020001 (J-24319-01)**

6. Remove drive shaft assembly.
  - Pry drive shaft front final drive using suitable tool.

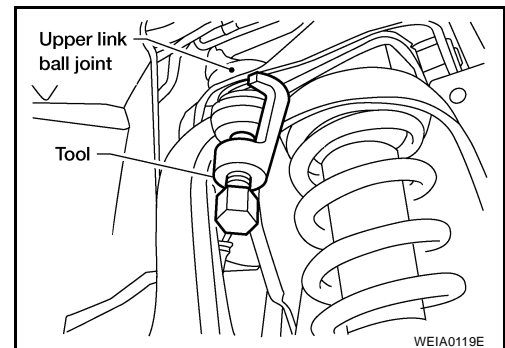

### INSPECTION AFTER REMOVAL

- Move joint up, down, left, right, and in axial direction. Check for any rough movement or significant looseness.
- Check boot for cracks or other damage, and for grease leakage.
- If damaged, disassemble drive shaft to verify damage, and repair or replace as necessary.

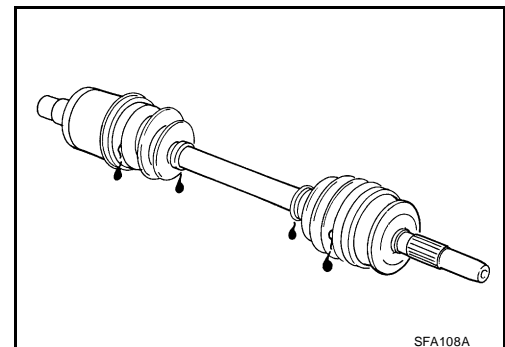

# DRIVE SHAFT

## INSTALLATION

Installation is in the reverse order of removal.

- When installing drive shaft onto front final drive, use Tool to prevent damage to the oil seal while inserting drive shaft. Slide drive shaft sliding joint and tap with a hammer to install securely.

**Tool number : KV38105500 (J-33904)**

### CAUTION:

**Never reuse the differential side oil seal.**

- Tighten wheel nuts to specification. Refer to [WT-6, "Rotation"](#).

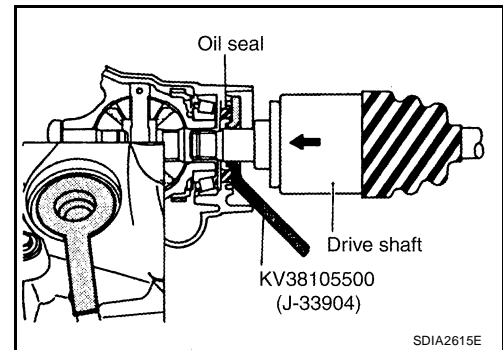

## Disassembly and Assembly

EDS0024J

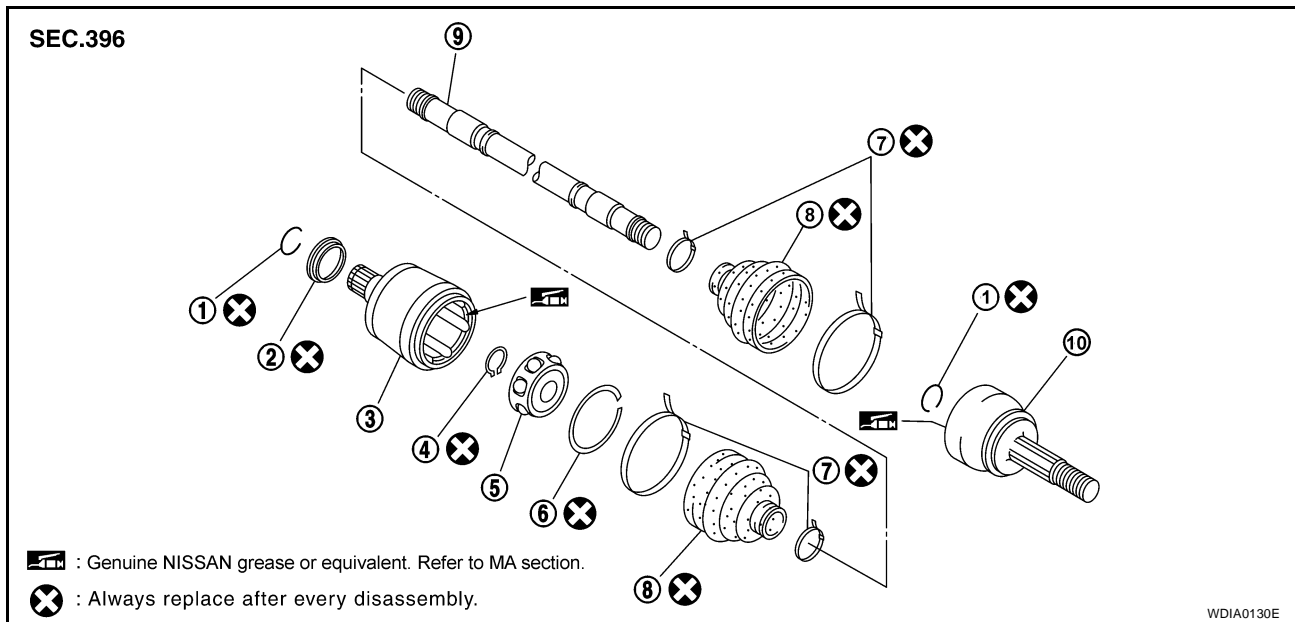

- |                        |  |                 |
|------------------------|--|-----------------|
| 1. Circlip             | 2. Dust cover                                    | 3. Housing      |
| 4. Snap ring           | 5. Ball cage, steel ball and inner race assembly | 6. Stopper ring |
| 7. Boot band           | 8. Boot  | 9. Shaft        |
| 10. Joint sub-assembly |  |                 |

## DISASSEMBLY

### Final Drive Side

- Mount the drive shaft in a vise.

### CAUTION:

**When mounting the drive shaft in a vise, use copper or aluminum plates between the vise and the drive shaft.**

- Remove boot bands and slide the boot back.
- Put matching marks on housing and shaft before separating joint assembly.

### CAUTION:

**Use paint or similar substance for matching marks. Do not scratch the surfaces.**



# DRIVE SHAFT

4. Remove the stopper ring using a suitable tool as shown, and pull the housing off.

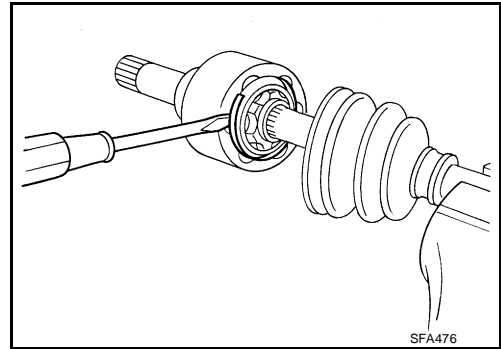

5. Remove the snap ring using a suitable tool, then remove the ball cage, steel ball, and inner race assembly from the shaft.

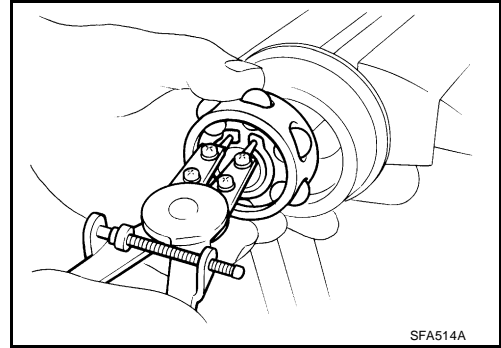

6. Remove the boot from the shaft.
7. Remove circlip and dust cover from the housing.
8. Clean the old grease off of the housing using paper towels.

## Wheel Side

1. Mount the drive shaft in a vise.

### CAUTION:

When mounting the drive shaft in a vise, use copper or aluminum plates between the vise and the drive shaft.

2. Remove the boot bands and slide the boot back.
3. Screw a sliding hammer or suitable tool 30 mm (1.18 in) or more into threaded part of joint sub-assembly. Pull joint sub-assembly off of shaft as shown.

### NOTE:

Align the sliding hammer and shaft and remove the joint sub-assembly by pulling directly.

### CAUTION:

- If the joint sub-assembly cannot be removed after five or more unsuccessful attempts, replace the entire drive shaft assembly.

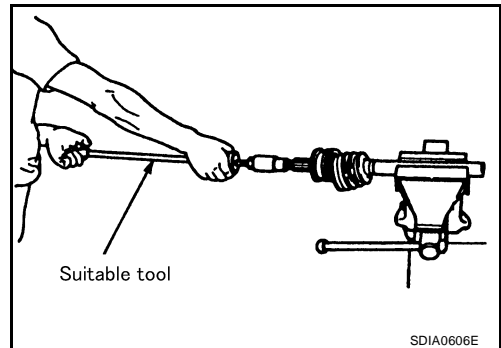

4. Remove boot from the shaft.
5. Remove circlip from the shaft.
6. While rotating the ball cage, clean the old grease off of the joint sub-assembly using paper towels.

## INSPECTION AFTER DISASSEMBLY

### Shaft

- Replace the shaft if there is any bending, cracking, or other damage.

### Joint Sub-assembly

- Check for any rough rotation or unusual axial looseness.
- Clean any foreign material from inside the joint sub-assembly.

A  
B  
C  
FAX  
E  
F  
G  
H  
I  
J  
K  
L  
M

# DRIVE SHAFT

- Check for any compression scars, cracks, or fractures.

## CAUTION:

If any irregular conditions are found in the joint sub-assembly components, replace the entire joint sub-assembly.

## Housing

### NOTE:

Housing, ball cage, steel ball, and inner race are in a set.

- Check for any compression scars, cracks, fractures, or unusual wear on the ball rolling surface.
- Check for any deformation of the boot installation components.

## Ball Cage

- Check the sliding surface for any compression scars, cracks, or fractures of sliding surface.

## Steel Ball

- Check for any compression scars, cracks, fractures, or unusual wear.

## Inner Race

- Check the ball sliding surface for any compression scars, cracks, or fractures.
- Check for any damage to the serrated part.

## ASSEMBLY

### Final Drive Side

1. Wrap the serrated part of the shaft with tape. Install the boot band and boot to shaft.

### NOTE:

Discard the old boot band and boot and use a new one for assembly.

2. Remove the tape wound around the serrated part of the shaft.

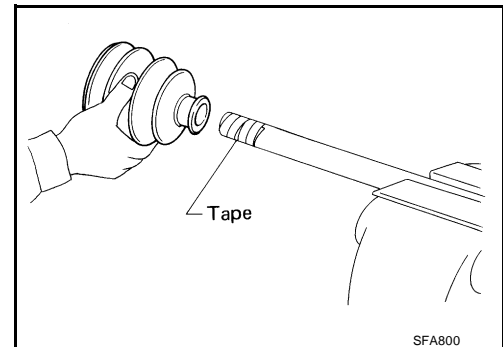

3. Install the ball cage, steel ball, and inner race assembly on the shaft, and secure them using the snap ring.

### NOTE:

Discard the old snap ring and use a new one for assembly.

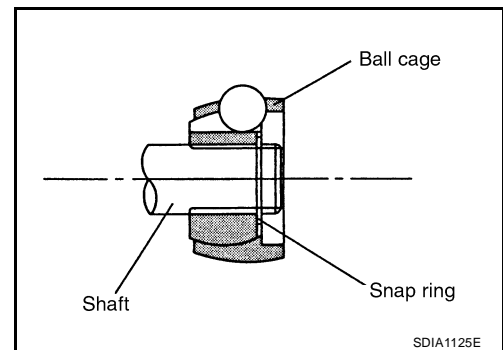

4. Insert the specified quantity of Genuine NISSAN Grease or equivalent, into the housing. Refer to [MA-11, "RECOMMENDED FLUIDS AND LUBRICANTS"](#).

**Grease capacity : 120 – 140 g (4.23 – 4.94 oz)**

### CAUTION:

If grease adheres to the boot mounting surface (indicated by \* marks) on shaft and housing, boot may come off. Remove all grease from surfaces.

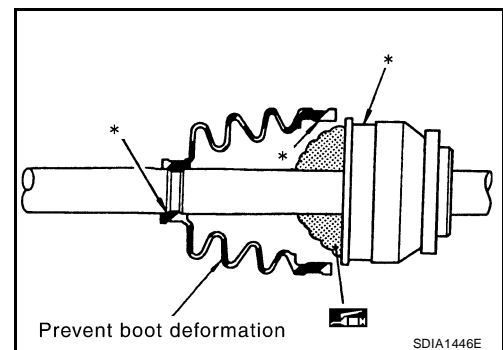

5. Install the stopper ring onto the housing.

# DRIVE SHAFT

## CAUTION:

- Do not reuse stopper rings.
- Make sure that housing and stopper ring are fully engaged.

6. Install the boot securely into the grooves (indicated by \* marks) as shown.

## CAUTION:

If there is grease on boot mounting surfaces (indicated by \* marks) of shaft and housing, boot may come off. Remove all grease from surfaces.

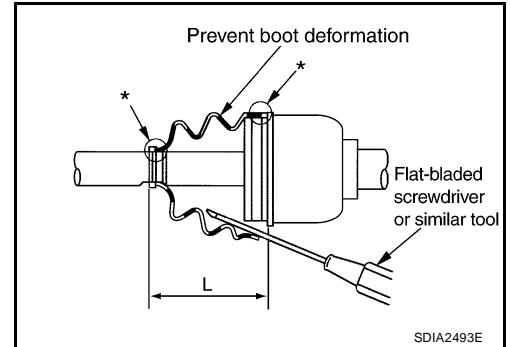

7. Check that the boot installation length "L" is the length indicated below. Insert a flat-tip screwdriver or similar tool into the large end of the boot. Bleed air from boot to prevent boot deformation.

**Boot installation length "L" : 163.9 - 164.3 mm (6.45 - 6.47 in)**

## CAUTION:

- The boot may break if the boot installation length is less than the specified value.
- Do not touch the tip of the screwdriver to the inside of the boot.

8. Secure the big and small ends of the boot with the new boot bands as shown.

## NOTE:

Discard not reuse boot bands.

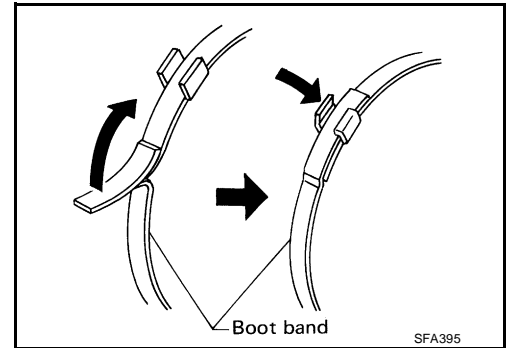

9. Secure housing and shaft and then make sure that they are in the correct position when rotating boot. Use a new boot band if the boot band needs to be loosened to reposition the boot.
10. Install circlip and dust cover to housing.

## NOTE:

Do not reuse circlip and dust cover.

## Wheel Side

1. Insert the Genuine NISSAN Grease or equivalent, into the joint sub-assembly serration hole until the grease begins to ooze from the ball groove and serration hole. Refer to [MA-11, "RECOMMENDED FLUIDS AND LUBRICANTS"](#). After inserting the grease, use a shop cloth to wipe off the grease that has oozed out.

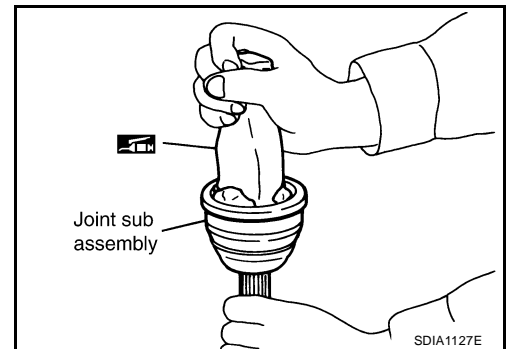

# DRIVE SHAFT

2. Wrap the serrated part of the shaft with tape. Install the boot band and boot onto the shaft. Do not damage the boot.

**NOTE:**

Discard the old boot band and boot and use a new one for assembly.

3. Remove the protective tape wound around the serrated part of the shaft.

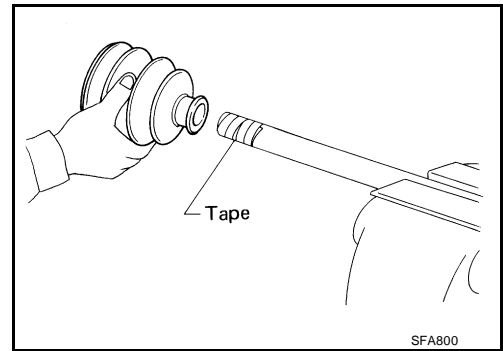

4. Attach the circlip to the shaft. The circlip must fit securely into the shaft groove. Attach the nut to the joint sub-assembly. Use a soft hammer to press-fit the circlip.

**NOTE:**

Discard the old circlip and use a new one for assembly.

5. Insert the specified quantity of Genuine NISSAN Grease or equivalent, into the joint sub-assembly and the large end of the boot. Refer to [MA-11, "RECOMMENDED FLUIDS AND LUBRICANTS"](#).

**Grease capacity : 115 – 135 g (4.01 – 4.76 oz)**

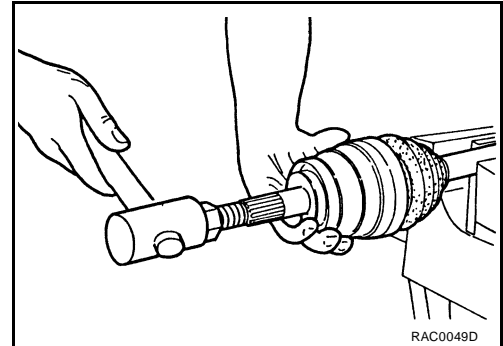

6. Install the boot securely into the grooves (indicated by the \* marks) as shown.

**CAUTION:**

If there is grease on the boot mounting surfaces (indicated by the \* marks) of the shaft and joint sub-assembly, the boot may come off. Remove all grease from the drive shaft surfaces.

7. Check that the boot installation length "L" is the specified length. Insert a flat-tip screwdriver or similar tool into the big side of the boot. Bleed the air from the boot to prevent boot deformation.

**Boot installation length "L" : 135.1 mm (5.32 in)**

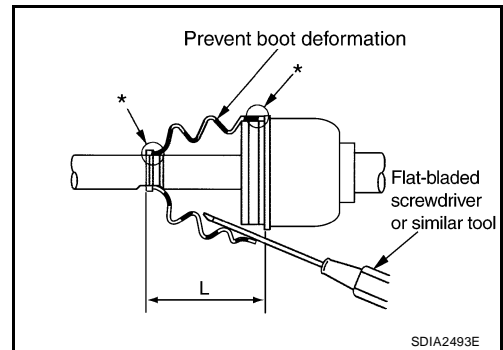

**CAUTION:**

- The boot may break if the boot installation length is less than the specified length.
- Do not contact inside surface of boot with the tip of the screwdriver.

8. Secure large and small ends of the boot using new boot bands using tool as shown.

**Tool number : KV40107300 ( — )**

**NOTE:**

Do not reuse boot bands.

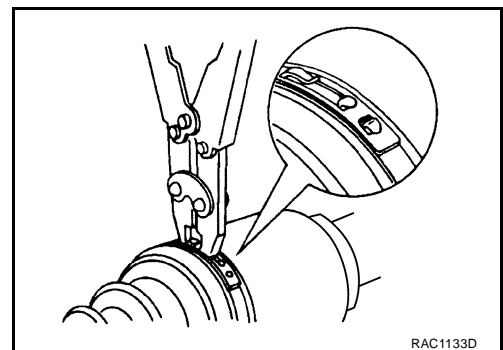

## DRIVE SHAFT

- Secure boot band so that dimension "M" meets specification as shown.

**Dimension "M" : 1.0 – 4.0 mm (0.39 – 1.57 in)**

9. After installing the housing to the shaft, rotate the boot to check that it is positioned correctly. If the boot is not positioned correctly, remove the old boot bands then reposition the boot and secure the boot with new boot bands.

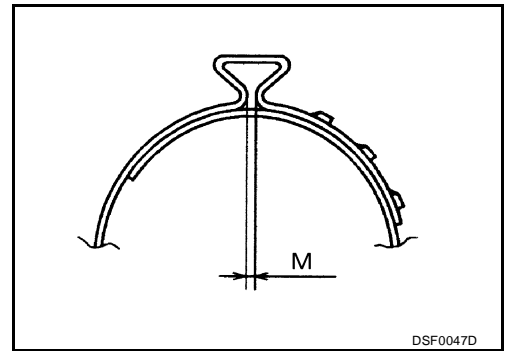

A

B

C

FAX

E

F

G

H

I

J

K

L

M

# SERVICE DATA AND SPECIFICATIONS (SDS)

## SERVICE DATA AND SPECIFICATIONS (SDS)

PF0:00030

### Wheel Bearing

EDS0024K

Wheel bearing axial end play	0.05 mm (0.0020 in) or less
------------------------------	-----------------------------

### Drive Shaft

EDS0034T

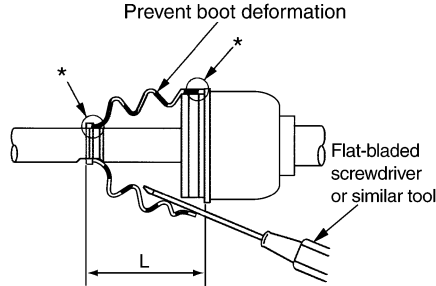

SDIA2493E

Drive shaft joint type	Final drive side	Rzeppa	
	Wheel side	Rzeppa	
Grease	Specification	Genuine NISSAN Grease or equivalent	
	Capacity	Final drive side	120 - 140 g (4.23 - 4.94 oz)
		Wheel side	115 - 135 g (4.01 - 4.76 oz)
Boot installed length "L"	Final drive side	163.9 - 164.3 mm (6.45 - 6.47 in)	
	Wheel side	135.1 mm (5.32 in)	