

LT  
**SECTION**  
**LIGHTING SYSTEM**

A  
B  
C  
D  
E  
F  
G  
H  
I  
J  
LT  
L  
M

**CONTENTS**

<p><b>PRECAUTIONS</b> ..... 4</p> <p>    Precautions for Supplemental Restraint System (SRS) “AIR BAG” and “SEAT BELT PRE-TENSIONER” ..... 4</p> <p>    General precautions for service operations ..... 4</p> <p><b>HEADLAMP (FOR USA)</b> ..... 5</p> <p>    Component Parts and Harness Connector Location... 5</p> <p>    System Description ..... 5</p> <p>        OUTLINE ..... 5</p> <p>        BATTERY SAVER CONTROL ..... 6</p> <p>        AUTO LIGHT OPERATION ..... 6</p> <p>        VEHICLE SECURITY SYSTEM (PANIC ALARM)... 6</p> <p>    CAN Communication System Description ..... 6</p> <p>    Schematic ..... 7</p> <p>    Wiring Diagram — H/LAMP — ..... 8</p> <p>    Terminals and Reference Values for BCM ..... 12</p> <p>    Terminals and Reference Values for IPDM E/R .... 12</p> <p>    How to Proceed With Trouble Diagnosis ..... 12</p> <p>    Preliminary Check ..... 12</p> <p>        CHECK POWER SUPPLY AND GROUND CIRCUIT ..... 12</p> <p>    CONSULT-II Function (BCM) ..... 12</p> <p>        CONSULT-II OPERATION ..... 12</p> <p>        WORK SUPPORT ..... 13</p> <p>        DATA MONITOR ..... 13</p> <p>        ACTIVE TEST ..... 14</p> <p>        SELF-DIAGNOSTIC RESULTS ..... 15</p> <p>    CONSULT-II Function (IPDM E/R) ..... 15</p> <p>        CONSULT-II OPERATION ..... 15</p> <p>        DATA MONITOR ..... 16</p> <p>        ACTIVE TEST ..... 17</p> <p>    Headlamp HI Does Not Illuminate (Both Sides) .... 17</p> <p>    Headlamp HI Does Not Illuminate (One Side) ..... 19</p> <p>    High Beam Indicator Lamp Does Not Illuminate ... 20</p> <p>    Headlamp LO Does Not Illuminate (Both Sides) ... 20</p> <p>    Headlamp LO Does Not Illuminate (One Side) ..... 22</p> <p>    Headlamps Do Not Turn OFF ..... 24</p> <p>    Aiming Adjustment ..... 25</p> <p>        LOW BEAM AND HIGH BEAM ..... 25</p> <p>        HEADLAMP AIMING ..... 26</p>	<p>    Bulb Replacement ..... 26</p> <p>        HEADLAMP BULB ..... 26</p> <p>        FRONT TURN SIGNAL/PARKING LAMP ..... 27</p> <p>        FRONT SIDE MARKER LAMP ..... 27</p> <p>    Removal and Installation ..... 27</p> <p>        FRONT COMBINATION LAMP ..... 27</p> <p>    Disassembly and Assembly ..... 28</p> <p>        DISASSEMBLY ..... 28</p> <p>        ASSEMBLY ..... 28</p> <p><b>HEADLAMP (FOR CANADA) - DAYTIME LIGHT SYSTEM -</b> ..... 29</p> <p>    Component Parts and Harness Connector Location.. 29</p> <p>    System Description ..... 29</p> <p>        OUTLINE ..... 30</p> <p>        DAYTIME LIGHT OPERATION ..... 31</p> <p>        COMBINATION SWITCH READING FUNCTION.. 31</p> <p>        AUTO LIGHT OPERATION ..... 31</p> <p>    CAN Communication System Description ..... 31</p> <p>    Schematic ..... 32</p> <p>    Wiring Diagram — DTRL — ..... 33</p> <p>    Terminals and Reference Values for BCM ..... 37</p> <p>    How to Proceed With Trouble Diagnosis ..... 37</p> <p>    Preliminary Check ..... 37</p> <p>        CHECK BCM CONFIGURATION ..... 37</p> <p>        INSPECTION FOR POWER SUPPLY AND GROUND CIRCUIT ..... 37</p> <p>        INSPECTION PARKING BRAKE SWITCH CIRCUIT ..... 37</p> <p>    CONSULT-II Functions ..... 38</p> <p>    Daytime Light Control Does Not Operate Properly (Normal Headlamps Operate Properly) ..... 38</p> <p>    Aiming Adjustment ..... 39</p> <p>    Bulb Replacement ..... 39</p> <p>    Removal and Installation ..... 39</p> <p>    Disassembly and Assembly ..... 39</p> <p><b>AUTO LIGHT SYSTEM</b> ..... 40</p> <p>    Component Parts and Harness Connector Location.. 40</p> <p>    System Description ..... 40</p> <p>        OUTLINE ..... 40</p> <p>        COMBINATION SWITCH READING FUNCTION.. 41</p>
---	---

EXTERIOR LAMP BATTERY SAVER CONTROL ..	41	COMBINATION SWITCH READING FUNCTION ..	65
DELAY TIMER FUNCTION .....	41	CAN Communication System Description .....	65
CAN Communication System Description .....	41	Wiring Diagram — TURN — .....	66
Major Components and Functions .....	41	Terminals and Reference Values for BCM .....	68
Schematic .....	42	How to Proceed With Trouble Diagnosis .....	68
Wiring Diagram — AUTO/L — .....	43	Preliminary Check .....	68
Terminals and Reference Values for BCM .....	46	CHECK POWER SUPPLY AND GROUND CIR-	
Terminals and Reference Values for IPDM E/R .....	46	CUIT .....	68
How to Proceed With Trouble Diagnosis .....	46	CONSULT-II Function (BCM) .....	68
Preliminary Check .....	46	CONSULT-II OPERATION .....	68
SETTING CHANGE FUNCTIONS .....	46	DATA MONITOR .....	69
CHECK BCM CONFIGURATION .....	46	ACTIVE TEST .....	70
CHECK POWER SUPPLY AND GROUND CIR-		Turn Signal Lamp Does Not Operate .....	70
CUIT .....	46	Rear Turn Signal Lamp Does Not Operate .....	71
CONSULT-II Function (BCM) .....	46	Hazard Warning Lamp Does Not Operate But Turn	
CONSULT-II OPERATION .....	46	Signal Lamps Operate .....	72
WORK SUPPORT .....	47	Turn Signal Indicator Lamp Does Not Operate .....	74
DATA MONITOR .....	48	Bulb Replacement .....	75
ACTIVE TEST .....	49	FRONT TURN SIGNAL LAMP .....	75
CONSULT-II Function (IPDM E/R) .....	50	REAR TURN SIGNAL LAMP .....	75
CONSULT-II OPERATION .....	50	Removal and Installation .....	75
DATA MONITOR .....	51	FRONT TURN SIGNAL LAMP .....	75
ACTIVE TEST .....	51	REAR TURN SIGNAL LAMP .....	75
Trouble Diagnosis Chart by Symptom .....	52	<b>LIGHTING AND TURN SIGNAL SWITCH .....</b>	<b>76</b>
Lighting Switch Inspection .....	52	Removal and Installation .....	76
Optical Sensor System Inspection .....	53	REMOVAL .....	76
Removal and Installation of Optical Sensor .....	54	INSTALLATION .....	76
REMOVAL .....	54	<b>HAZARD SWITCH .....</b>	<b>77</b>
<b>FRONT FOG LAMP .....</b>	<b>55</b>	Removal and Installation .....	77
Component Parts and Harness Connector Location ..	55	REMOVAL .....	77
System Description .....	55	INSTALLATION .....	77
OUTLINE .....	55	<b>COMBINATION SWITCH .....</b>	<b>78</b>
COMBINATION SWITCH READING FUNCTION ..	56	Wiring Diagram — COMBSW — .....	78
EXTERIOR LAMP BATTERY SAVER CONTROL ..	56	Combination Switch Reading Function .....	79
CAN Communication System Description .....	56	CONSULT-II Function (BCM) .....	79
Wiring Diagram — F/FOG — .....	57	CONSULT-II OPERATION .....	79
Terminals and Reference Values for BCM .....	59	DATA MONITOR .....	80
Terminals and Reference Values for IPDM E/R .....	59	Combination Switch Inspection .....	81
How to Proceed With Trouble Diagnosis .....	59	Removal and Installation .....	83
Preliminary Check .....	59	Switch Circuit Inspection .....	83
CHECK POWER SUPPLY AND GROUND CIR-		<b>STOP LAMP .....</b>	<b>84</b>
CUIT .....	59	System Description .....	84
CONSULT-II Functions .....	59	Wiring Diagram — STOP/L — .....	85
Front Fog Lamps Do Not Illuminate (Both Sides) ...	59	Bulb Replacement .....	87
Front Fog Lamp Does Not Illuminate (One Side) ...	60	HIGH-MOUNTED STOP LAMP .....	87
Aiming Adjustment .....	61	STOP LAMP .....	87
Bulb Replacement .....	62	Removal and Installation .....	87
REMOVAL .....	62	HIGH-MOUNTED STOP LAMP .....	87
INSTALLATION .....	62	STOP LAMP .....	87
Removal and Installation .....	62	<b>BACK-UP LAMP .....</b>	<b>88</b>
FOG LAMP .....	62	Wiring Diagram — BACK/L — .....	88
<b>TURN SIGNAL AND HAZARD WARNING LAMPS ..</b>	<b>63</b>	Bulb Replacement .....	89
Component Parts and Harness Connector Location ..	63	Removal and Installation .....	89
System Description .....	63	<b>PARKING, LICENSE PLATE AND TAIL LAMPS .....</b>	<b>90</b>
OUTLINE .....	63	Component Parts and Harness Connector Location ..	90
TURN SIGNAL OPERATION .....	63	System Description .....	90
HAZARD LAMP OPERATION .....	64	OPERATION BY LIGHTING SWITCH .....	90
REMOTE KEYLESS ENTRY SYSTEM OPERA-		COMBINATION SWITCH READING FUNCTION ..	91
TION .....	64	EXTERIOR LAMP BATTERY SAVER CONTROL ..	91

CAN Communication System Description .....	91	System Description .....	116	
Schematic .....	92	MODELS WITHOUT POWER DOOR LOCKS .	116	A
Wiring Diagram — TAIL/L — .....	93	MODELS WITH POWER DOOR LOCKS .....	117	
Terminals and Reference Values for BCM .....	97	Schematic / With Power Door Locks .....	121	
Terminals and Reference Values for IPDM E/R ....	97	Wiring Diagram—INT/L—/With Power Door Locks	123	B
How to Proceed With Trouble Diagnosis .....	97	Schematic / Without Power Door Locks .....	130	
Preliminary Check .....	97	Wiring Diagram — INT/L — / Without Power Door		
CHECK POWER SUPPLY AND GROUND CIR-		Locks .....	131	C
CUIT .....	97	Terminals and Reference Values for BCM .....	135	
CONSULT-II Functions .....	97	How to Proceed With Trouble Diagnosis .....	135	
Parking, Side Marker, License Plate and/or Tail		Preliminary Check .....	135	
Lamps Do Not Illuminate .....	97	INSPECTION FOR POWER SUPPLY AND		D
Parking, Side Marker, License Plate and Tail Lamps		GROUND CIRCUIT .....	135	
Do Not Turn OFF (After Approx. 10 Minutes) .....	104	CONSULT-II Function (BCM) .....	135	
Bulb Replacement .....	104	CONSULT-II OPERATION .....	135	E
FRONT PARKING LAMP .....	104	WORK SUPPORT .....	136	
LICENSE PLATE LAMP .....	104	DATA MONITOR .....	137	
TAIL LAMP .....	104	ACTIVE TEST .....	138	F
Removal and Installation .....	104	Room/Map Lamp Does Not Turn ON or OFF Prop-		
FRONT PARKING LAMP .....	104	erly .....	138	
LICENSE PLATE LAMP .....	104	MODELS WITHOUT POWER DOOR LOCKS .	138	G
TAIL LAMP .....	104	Room/Map Lamp Control Does Not Operate .....	139	
<b>REAR COMBINATION LAMP .....</b>	<b>105</b>	MODELS WITH POWER DOOR LOCKS .....	139	
Bulb Replacement .....	105	Room Lamp 2nd Row Control Does Not Operate.	141	
REMOVAL .....	105	All Interior Room Lamps Do Not Operate .....	142	H
INSTALLATION .....	105	MODELS WITH POWER DOOR LOCKS .....	142	
Removal and Installation .....	105	<b>ILLUMINATION .....</b>	<b>143</b>	
REMOVAL .....	105	Component Parts and Harness Connector Location	143	I
INSTALLATION .....	105	System Description .....	143	
<b>TRAILER TOW .....</b>	<b>106</b>	ILLUMINATION OPERATION BY LIGHTING		
Component Parts and Harness Connector Location	106	SWITCH .....	144	J
System Description .....	106	EXTERIOR LAMP BATTERY SAVER CONTROL	144	
TRAILER TAIL LAMP OPERATION .....	107	CAN Communication System Description .....	145	
TRAILER STOP, TURN SIGNAL AND HAZARD		Schematic .....	146	
LAMP OPERATION .....	107	Wiring Diagram — ILL — .....	149	LT
TRAILER POWER SUPPLY OPERATION .....	107	Removal and Installation .....	157	
TRAILER BACK-UP LAMPS OPERATION .....	108	ILLUMINATION CONTROL SWITCH .....	157	
Schematic .....	109	<b>BULB SPECIFICATIONS .....</b>	<b>158</b>	L
Wiring Diagram — T/TOW — .....	110	Headlamp .....	158	
<b>INTERIOR ROOM LAMP .....</b>	<b>115</b>	Exterior Lamp .....	158	
Component Parts and Harness Connector Location	115	Interior Lamp/Illumination .....	158	M

# PRECAUTIONS

## PRECAUTIONS

PF0:00011

### Precautions for Supplemental Restraint System (SRS) “AIR BAG” and “SEAT BELT PRE-TENSIONER”

EKS00B0I

The Supplemental Restraint System such as “AIR BAG” and “SEAT BELT PRE-TENSIONER”, used along with a front seat belt, helps to reduce the risk or severity of injury to the driver and front passenger for certain types of collision. This system includes seat belt switch inputs and dual stage front air bag modules. The SRS system uses the seat belt switches to determine the front air bag deployment, and may only deploy one front air bag, depending on the severity of a collision and whether the front occupants are belted or unbelted. Information necessary to service the system safely is included in the SRS and SB section of this Service Manual.

#### **WARNING:**

- To avoid rendering the SRS inoperative, which could increase the risk of personal injury or death in the event of a collision which would result in air bag inflation, all maintenance must be performed by an authorized NISSAN/INFINITI dealer.
- Improper maintenance, including incorrect removal and installation of the SRS, can lead to personal injury caused by unintentional activation of the system. For removal of Spiral Cable and Air Bag Module, see the SRS section.
- Do not use electrical test equipment on any circuit related to the SRS unless instructed to in this Service Manual. SRS wiring harnesses can be identified by yellow and/or orange harnesses or harness connectors.

#### General precautions for service operations

EKS00B0J

- Never work with wet hands.
- Turn the lighting switch OFF before disconnecting and connecting the connector.
- When checking the headlamp on/off operation, check it on vehicle and with the power connected to the vehicle-side connector.
- Do not touch the headlamp bulb glass surface with bare hands or allow oil or grease to get on it. Do not touch the headlamp bulb just after the headlamp is turned off, because it is very hot.
- When the bulb has burned out, wrap it in a thick vinyl bag and discard. Do not break the bulb.
- Leaving the bulb removed from the headlamp housing for a long period of time can deteriorate the performance of the lens and reflector (dirt, clouding). Always prepare a new bulb and have it on hand when replacing the bulb.
- Do not use organic solvent (paint thinner or gasoline) to clean lamps and to remove old sealant.

# HEADLAMP (FOR USA)

## HEADLAMP (FOR USA)

PFP:26010

### Component Parts and Harness Connector Location

EKS00BOL

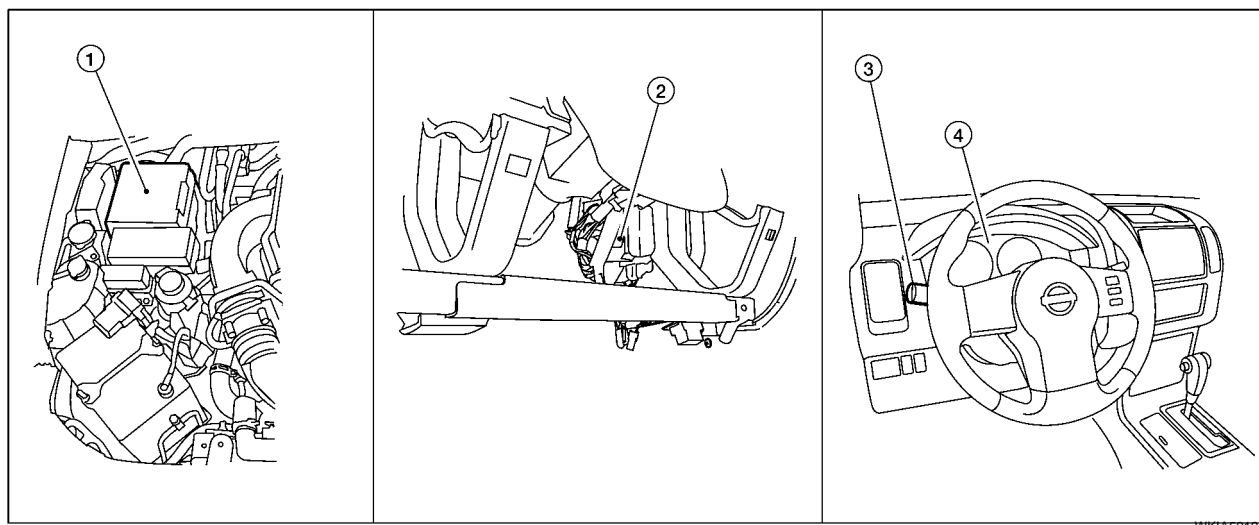

1. IPDM E/R  
E122, E123, E124
2. BCM  
M18, M20  
(view with lower instrument panel LH removed)
3. Combination switch (lighting switch)  
M28
4. Combination meter  
M24

### System Description

EKS00CLU

Control of the headlamp system operation is dependent upon the position of the combination switch (lighting switch). When the lighting switch is placed in the 2ND position, the BCM (body control module) receives input requesting the headlamps (and tail lamps) illuminate. This input is communicated to the IPDM E/R (intelligent power distribution module engine room) across the CAN communication lines. The CPU (central processing unit) of the IPDM E/R controls the headlamp high and headlamp low relay coils. When energized, these relays direct power to the respective headlamps, which then illuminate.

### OUTLINE

Power is supplied at all times

- to headlamp high relay, located in the IPDM E/R, and
- to headlamp low relay, located in the IPDM E/R, and
- to ignition relay, located in the IPDM E/R, and
- through 20A fuse (No. 53, located in the IPDM E/R)
- to CPU of the IPDM E/R, and
- through 50A fusible link (letter **g**, located in the fuse and fusible link box)
- to BCM terminal 70.

With the ignition switch in the ON or START position, power is supplied

- to ignition relay, located in the IPDM E/R, and
- through 10A fuse [No. 1, located in the fuse block (J/B)]
- to BCM terminal 38.

Ground is supplied

- to BCM terminal 67
- through grounds M57, M61 and M79, and
- to IPDM E/R terminals 38 and 59
- through grounds E9, E15 (all) and E24 (VQ40DE engine only).

# HEADLAMP (FOR USA)

## Low Beam Operation

With the lighting switch in 2ND position, the BCM receives input requesting the headlamps to illuminate. This input is communicated to the IPDM E/R across the CAN communication lines. The CPU of the IPDM E/R controls the headlamp low relay coil. When energized, this relay directs power

- through 15A fuse (No. 41, located in the IPDM E/R)
- through IPDM E/R terminal 54
- to front combination lamp RH (headlamp) terminal 3, and
- through 15A fuse (No. 40, located in the IPDM E/R)
- through IPDM E/R terminal 52
- to front combination lamp LH (headlamp) terminal 3.

Ground is supplied

- to front combination lamp LH and RH (headlamp) terminal 2
- through grounds E9, E15 (all) and E24 (VQ40DE engine only).

With power and ground supplied, low beam headlamps illuminate.

## High Beam Operation/Flash-to-Pass Operation

With the lighting switch in 2ND position and placed in HIGH or PASS position, the BCM receives input requesting the headlamp high beams to illuminate. This input is communicated to the IPDM E/R across the CAN communication lines. The CPU of the combination meter controls the ON/OFF status of the HIGH BEAM indicator. The CPU of the IPDM E/R controls the headlamp high relay coil. When energized, this relay directs power

- through 10A fuse (No. 34, located in the IPDM E/R)
- through IPDM E/R terminal 56
- to front combination lamp RH (headlamp) terminal 1, and
- through 10A fuse (No. 35, located in the IPDM E/R)
- through IPDM E/R terminal 55
- to front combination lamp LH (headlamp) terminal 1.

Ground is supplied

- to front combination lamp LH and RH (headlamp) terminal 2
- through grounds E9, E15 (all) and E24 (VQ40DE engine only).

With power and ground supplied, the high beam headlamps illuminate.

## BATTERY SAVER CONTROL

When the combination switch (lighting switch) is in the 2ND position (ON), and the ignition switch is turned from ON or ACC to OFF, the battery saver control feature is activated.

Under this condition, the headlamps remain illuminated for 5 minutes, unless the combination switch (lighting switch) position is changed. If the combination switch (lighting switch) position is changed, then the headlamps are turned off.

## AUTO LIGHT OPERATION

Refer to [LT-40. "System Description"](#) for auto light operation.

## VEHICLE SECURITY SYSTEM (PANIC ALARM)

The vehicle security system (panic alarm) will flash the high beams if the system is triggered. Refer to [BL-82. "PANIC ALARM OPERATION"](#).

## CAN Communication System Description

Refer to [LAN-22. "CAN COMMUNICATION"](#).

EKS00B0N

# HEADLAMP (FOR USA)

## Schematic

EKS00B00

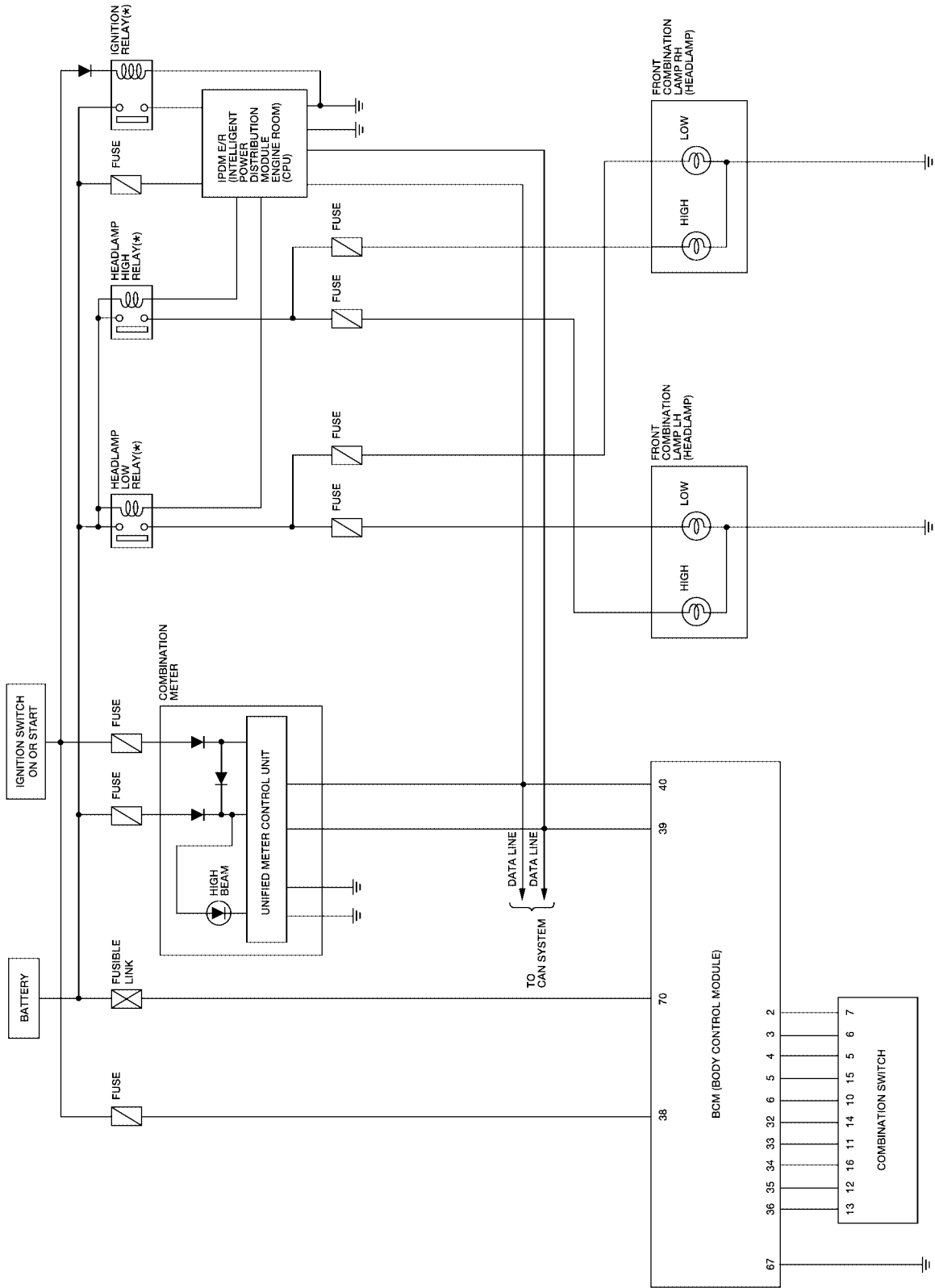

WKWA4346E

A  
B  
C  
D  
E  
F  
G  
H  
I  
J  
LT  
L  
M

# HEADLAMP (FOR USA)

EKS00BOP

## Wiring Diagram — H/LAMP —

LT-H/LAMP-01

— : DATA LINE

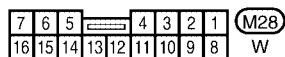
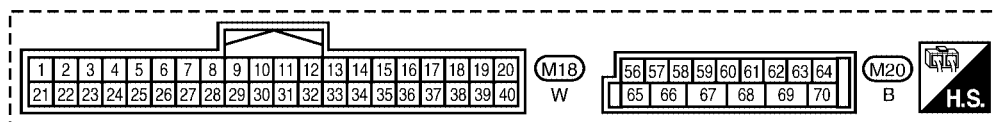
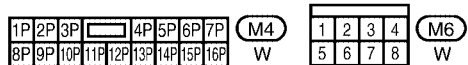
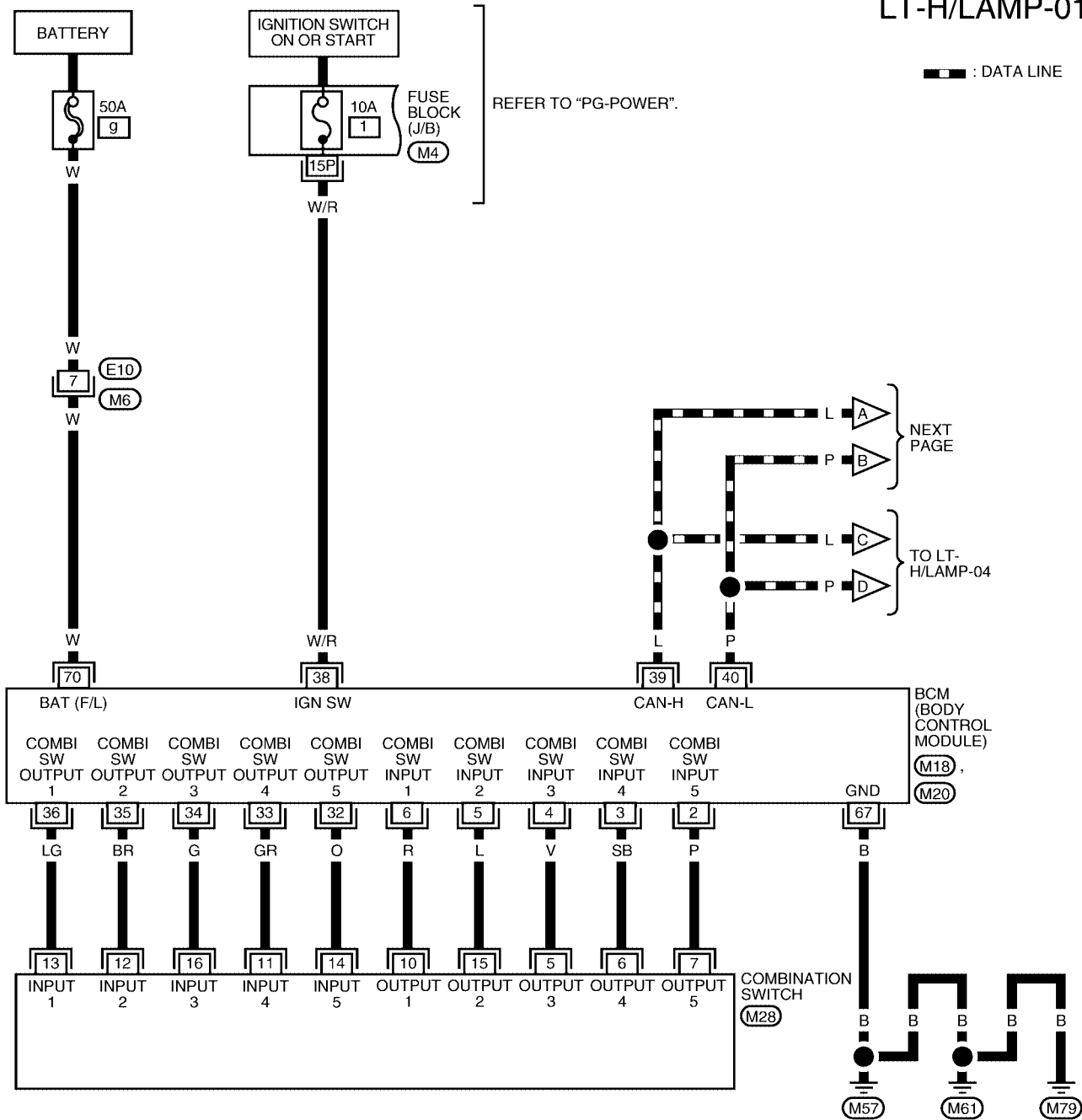

WKWA4347E



# HEADLAMP (FOR USA)

## LT-H/LAMP-02

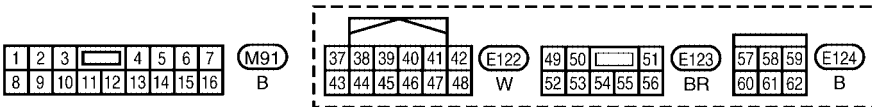
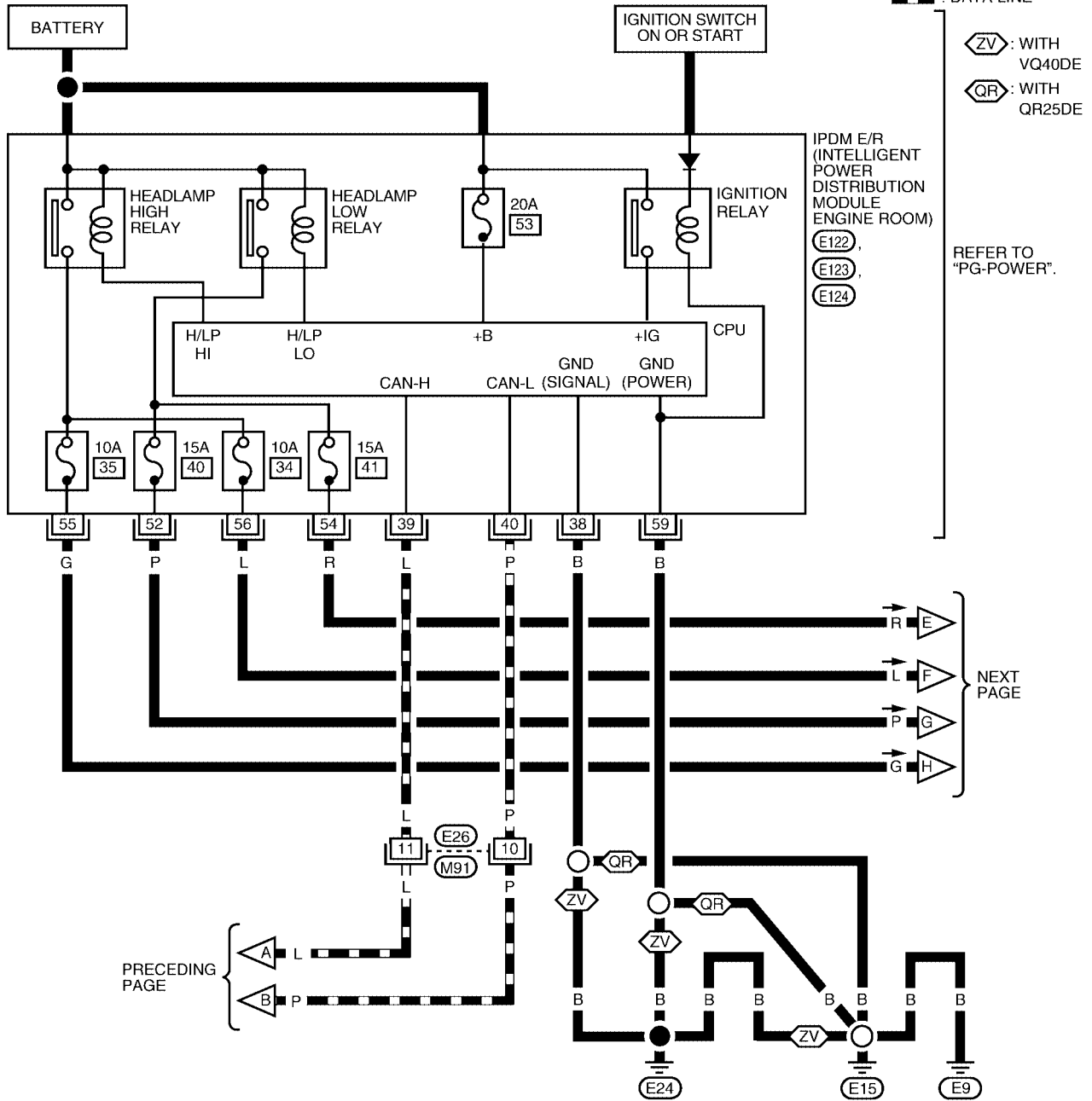

WKWA4348E

# HEADLAMP (FOR USA)

LT-H/LAMP-03

 : WITH VQ40DE

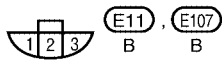
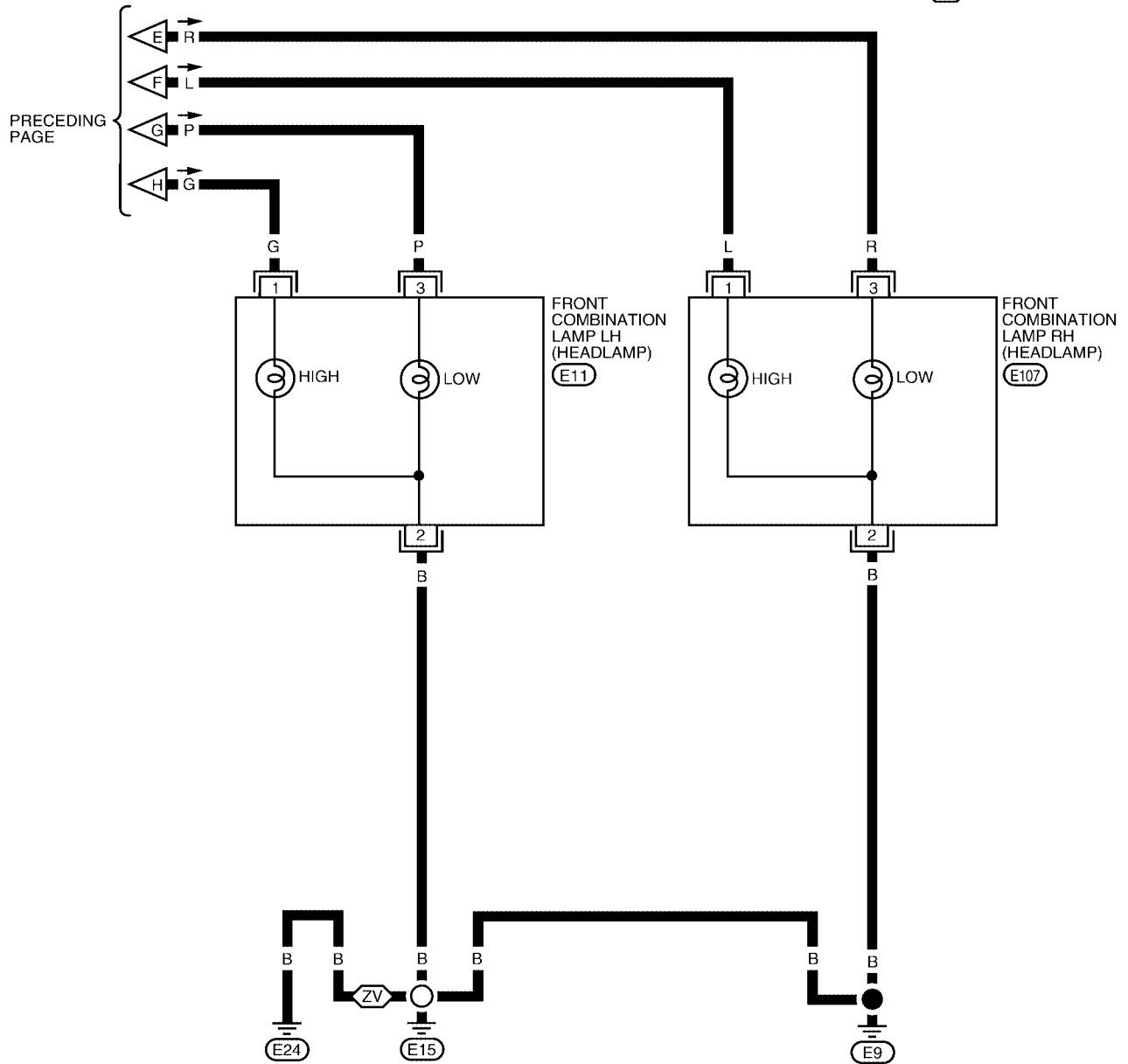

WKWA2193E

# HEADLAMP (FOR USA)

LT-H/LAMP-04

— : DATA LINE

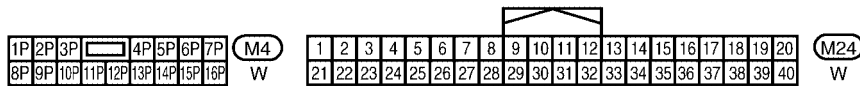
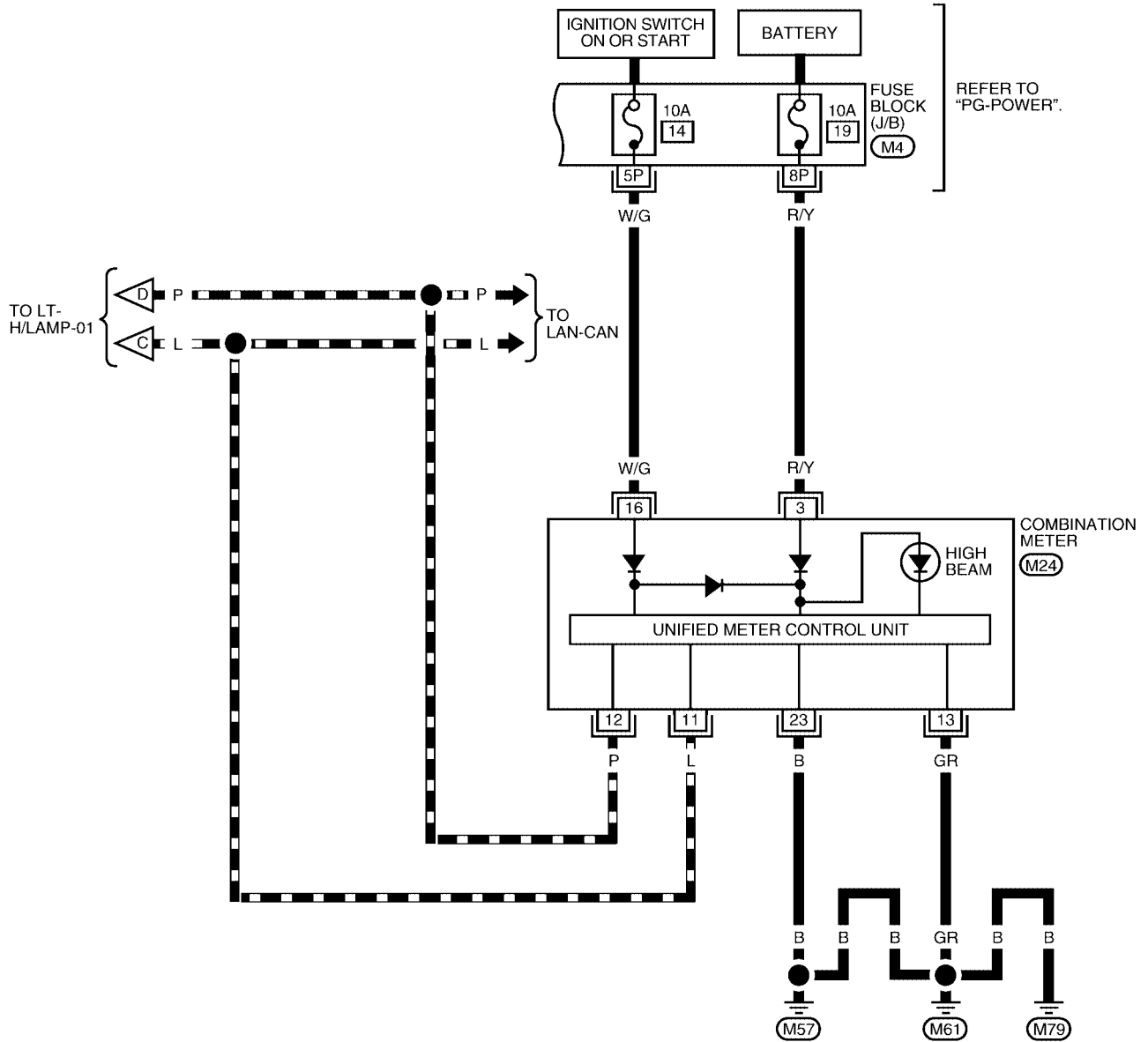

WKWA4349E

# HEADLAMP (FOR USA)

## Terminals and Reference Values for BCM

EKS00CLV

Refer to [BCS-12, "Terminals and Reference Values for BCM"](#) .

## Terminals and Reference Values for IPDM E/R

EKS00CLW

Refer to [PG-29, "Terminals and Reference Values for IPDM E/R"](#) .

## How to Proceed With Trouble Diagnosis

EKS00CLX

1. Confirm the symptom or customer complaint.
2. Understand operation description and function description. Refer to [LT-5, "System Description"](#) .
3. Perform the Preliminary Check. Refer to [LT-12, "Preliminary Check"](#) .
4. Check symptom and repair or replace the cause of malfunction.
5. Does the headlamp operate normally? If YES: GO TO 6. If NO: GO TO 4.
6. Inspection End.

## Preliminary Check

EKS00CLY

### CHECK POWER SUPPLY AND GROUND CIRCUIT

Refer to [BCS-16, "BCM Power Supply and Ground Circuit Check"](#) and [PG-31, "IPDM E/R Power/Ground Circuit Inspection"](#) .

## CONSULT-II Function (BCM)

EKS00CLZ

CONSULT-II can display each diagnostic item using the diagnostic test modes shown following.

BCM diagnostic test item	Diagnostic mode	Description
Inspection by part	WORK SUPPORT	Supports inspections and adjustments. Commands are transmitted to the BCM for setting the status suitable for required operation, input/output signals are received from the BCM and received data is displayed.
	DATA MONITOR	Displays BCM input/output data in real time.
	ACTIVE TEST	Operation of electrical loads can be checked by sending drive signal to them.
	SELF-DIAG RESULTS	Displays BCM self-diagnosis results.
	CAN DIAG SUPPORT MNTR	The result of transmit/receive diagnosis of CAN communication can be read.
	ECU PART NUMBER	BCM part number can be read.
	CONFIGURATION	Performs BCM configuration read/write functions.

## CONSULT-II OPERATION

### CAUTION:

If CONSULT-II is used with no connection of CONSULT-II CONVERTER, malfunctions might be detected in self-diagnosis depending on control unit which carries out CAN communication.

1. With the ignition switch OFF, connect CONSULT-II and CONSULT-II CONVERTER to the data link connector, then turn ignition switch ON.

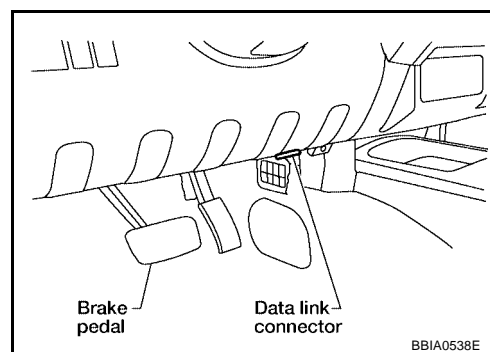

# HEADLAMP (FOR USA)

2. Touch "START (NISSAN BASED VHCL)".

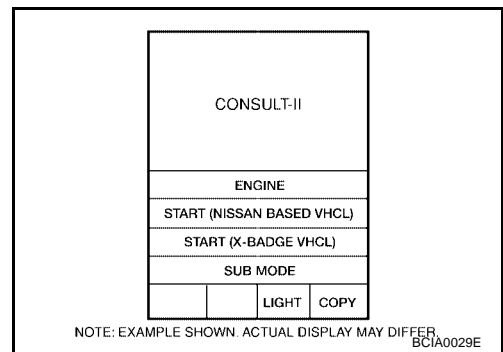

3. Touch "BCM" on "SELECT SYSTEM" screen.  
If "BCM" is not indicated, go to [GI-41, "CONSULT-II Data Link Connector \(DLC\) Circuit"](#).

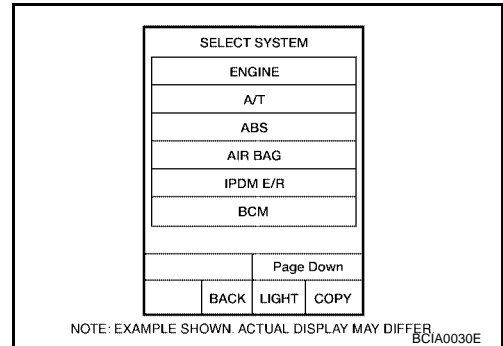

4. Touch "HEAD LAMP" on "SELECT TEST ITEM" screen.

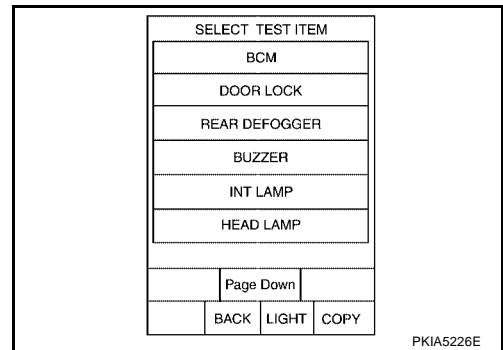

## WORK SUPPORT

### Operation Procedure

1. Touch "HEAD LAMP" on "SELECT TEST ITEM" screen.
2. Touch "WORK SUPPORT" on "SELECT DIAG MODE" screen.
3. Touch item on "SELECT WORK ITEM" screen.
4. Touch "START".
5. Touch "CHANGE SETT".
6. The setting will be changed and "CUSTOMIZING COMPLETED" will be displayed.
7. Touch "END".

### Display Item List

Item	Description	CONSULT-II	Factory setting
BATTERY SAVER SET	Exterior lamp battery saver control mode can be changed in this mode. Selects exterior lamp battery saver control mode between ON/OFF.	ON	×
		OFF	—

## DATA MONITOR

### Operation Procedure

1. Touch "HEAD LAMP" on "SELECT TEST ITEM" screen.
2. Touch "DATA MONITOR" on "SELECT DIAG MODE" screen.
3. Touch either "ALL SIGNALS" or "SELECTION FROM MENU" on the "SELECT MONITOR ITEM" screen.

A  
B  
C  
D  
E  
F  
G  
H  
I  
J  
LT

## HEADLAMP (FOR USA)

ALL SIGNALS	Monitors all the signals.
SELECTION FROM MENU	Selects and monitors individual signal.

4. Touch "START".
5. When "SELECTION FROM MENU" is selected, touch individual items to be monitored. When "ALL SIGNALS" is selected, all the items will be monitored.
6. Touch "RECORD" while monitoring, then the status of the monitored item can be recorded. To stop recording, touch "STOP".

### Display Item List

Monitor item		Contents
IGN ON SW	"ON/OFF"	Displays "IGN position (ON)/OFF, ACC position (OFF)" judged from the ignition switch signal.
ACC ON SW	"ON/OFF"	Displays "ACC (ON)/OFF, Ignition OFF (OFF)" status judged from ignition switch signal.
HI BEAM SW	"ON/OFF"	Displays status (high beam switch: ON/Others: OFF) of high beam switch judged from lighting switch signal.
HEAD LAMP SW 1	"ON/OFF"	Displays status (headlamp switch 1: ON/Others: OFF) of headlamp switch 2 judged from lighting switch signal.
HEAD LAMP SW 2	"ON/OFF"	Displays status (headlamp switch 2: ON/Others: OFF) of headlamp switch 2 judged from lighting switch signal.
LIGHT SW 1ST	"ON/OFF"	Displays status (lighting switch 1st position: ON/Others: OFF) of lighting switch judged from lighting switch signal.
AUTO LIGHT SW	"ON/OFF"	Displays status of the lighting switch as judged from the lighting switch signal. (AUTO position: ON/Other than AUTO position: OFF)
PASSING SW	"ON/OFF"	Displays status (flash-to-pass switch: ON/Others: OFF) of flash-to-pass switch judged from lighting switch signal.
FR FOG SW	"ON/OFF"	Displays status (front fog lamp switch: ON/Others: OFF) of front fog lamp switch judged from lighting switch signal.
DOOR SW-DR	"ON/OFF"	Displays status of the driver door as judged from the driver door switch signal. (Door is open: ON/Door is closed: OFF)
DOOR SW-AS	"ON/OFF"	Displays status of the passenger door as judged from the passenger door switch signal. (Door is open: ON/Door is closed: OFF)
DOOR SW-RR	"ON/OFF"	Displays status of the rear door as judged from the rear door switch (RH) signal. (Door is open: ON/Door is closed: OFF)
DOOR SW-RL	"ON/OFF"	Displays status of the rear door as judged from the rear door switch (LH) signal. (Door is open: ON/Door is closed: OFF)
BACK DOOR SW	"ON/OFF"	Not used.
TURN SIGNAL R	"ON/OFF"	Displays status (Turn right: ON/Others: OFF) as judged from lighting switch signal.
TURN SIGNAL L	"ON/OFF"	Displays status (Turn left: ON/Others: OFF) as judged from lighting switch signal.
CARGO LAMP SW	"ON/OFF"	Displays status of cargo lamp switch.
OPTICAL SENSOR	[0 - 5V]	Displays "ambient light (close to 5V when dark/close to 0V when light)" judged from optical sensor signal.

### ACTIVE TEST

#### Operation Procedure

1. Touch "HEAD LAMP" on "SELECT TEST ITEM" screen.
2. Touch "ACTIVE TEST" on "SELECT DIAG MODE" screen.
3. Touch item to be tested and check operation of the selected item.
4. During the operation check, touching "BACK" deactivates the operation.

# HEADLAMP (FOR USA)

## Display Item List

Test item	Description
TAIL LAMP	Allows tail lamp relay to operate by switching ON-OFF.
HEAD LAMP	Allows headlamp relay (HI, LO) to operate by switching ON-OFF.
FR FOG LAMP	Allows fog lamp relay to operate by switching ON-OFF.
CARGO LAMP	Allows cargo lamp to operate by switching ON-OFF.
CORNERING LAMP	Not used.

## SELF-DIAGNOSTIC RESULTS

### Operation Procedure

1. Touch "BCM" on "SELECT TEST ITEM" screen.
2. Touch "SELF-DIAG RESULTS" on "SELECT DIAG MODE" screen.
3. Self-diagnostic results are displayed.

## Display Item List

Monitored item	CONSULT-II display	Description
CAN communication	CAN communication [U1000]	Malfunction is detected in CAN communication.
CAN communication system	CAN communication system 1 to 6 [U1000]	Malfunction is detected in CAN system.

## CONSULT-II Function (IPDM E/R)

EKS00CM0

CONSULT-II can display each diagnostic item using the diagnostic test modes shown following.

IPDM E/R diagnostic mode	Description
SELF-DIAG RESULTS	Displays IPDM E/R self-diagnosis results.
DATA MONITOR	Displays IPDM E/R input/output data in real time.
CAN DIAG SUPPORT MNTR	The result of transmit/receive diagnosis of CAN communication can be read.
ACTIVE TEST	Operation of electrical loads can be checked by sending drive signal to them.

## CONSULT-II OPERATION

### CAUTION:

If CONSULT-II is used with no connection of CONSULT-II CONVERTER, malfunctions might be detected in self-diagnosis depending on control unit which carries out CAN communication.

1. With the ignition switch OFF, connect CONSULT-II and CONSULT-II CONVERTER to the data link connector, then turn the ignition switch ON.

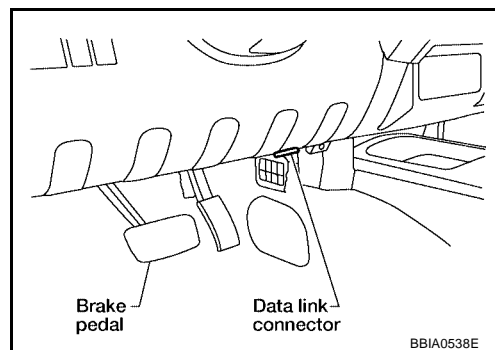

# HEADLAMP (FOR USA)

2. Touch "START (NISSAN BASED VHCL)".

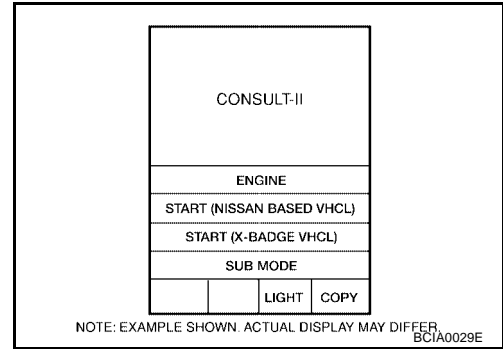

3. Touch "IPDM E/R" on "SELECT SYSTEM" screen. If "IPDM E/R" is not displayed, refer to [GI-41, "CONSULT-II Data Link Connector \(DLC\) Circuit"](#).

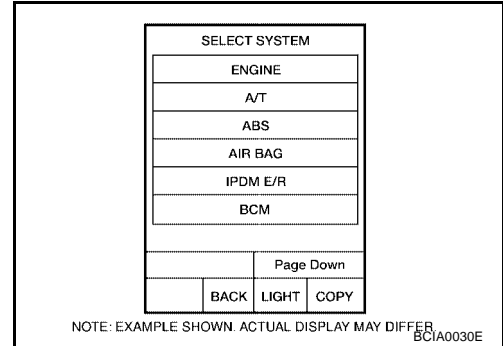

4. Select the desired part to be diagnosed on the "SELECT DIAG MODE" screen.

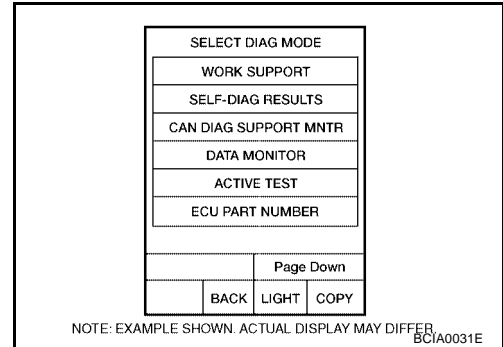

## DATA MONITOR

### Operation Procedure

1. Touch "DATA MONITOR" on "SELECT DIAG MODE" screen.
2. Touch "ALL SIGNALS", "MAIN SIGNALS" or "SELECTION FROM MENU" on the "SELECT MONITOR ITEM" screen.

ALL SIGNALS	All items will be monitored.
MAIN SIGNALS	Monitor the predetermined item.
SELECTION FROM MENU	Select any item for monitoring.

3. Touch "START".
4. Touch the required monitoring item on "SELECTION FROM MENU". In "ALL SIGNALS", all items are monitored. In "MAIN SIGNALS", predetermined items are monitored.
5. Touch "RECORD" while monitoring to record the status of the item being monitored. To stop recording, touch "STOP".



# HEADLAMP (FOR USA)

## All Signals, Main Signals, Selection From Menu

Item name	CONSULT-II screen display	Display or unit	Monitor item selection			Description
			ALL SIGNALS	MAIN SIGNALS	SELECTION FROM MENU	
Parking, license plate and tail lamps request	TAIL&CLR REQ	ON/OFF	×	×	×	Signal status input from BCM
Headlamp low beam request	HL LO REQ	ON/OFF	×	×	×	Signal status input from BCM
Headlamp high beam request	HL HI REQ	ON/OFF	×	×	×	Signal status input from BCM
Daytime lights request	DTRL REQ	ON/OFF	×	–	×	Signal status input from BCM
Front fog lamps request	FR FOG REQ	ON/OFF	×	×	×	Signal status input from BCM

### NOTE:

Perform monitoring of IPDM E/R data with the ignition switch ON. When the ignition switch is at ACC, the display may not be correct.

### ACTIVE TEST

#### Operation Procedure

1. Touch "ACTIVE TEST" on "SELECT DIAG MODE" screen.
2. Touch "EXTERNAL LAMPS" on "SELECT TEST ITEM" screen.
3. Touch item to be tested, and check operation.
4. Touch "START".
5. Touch "STOP" while testing to stop the operation.

Test item	CONSULT-II screen display	Description
Tail lamp relay output	TAIL LAMP	Allows tail lamp relay to operate by switching operation ON-OFF at your option.
Headlamp relay (HI, LO) output	LAMPS	Allows headlamp relay (HI, LO) to operate by switching operation (OFF, HI, LO) at your option (Head lamp high beam repeats ON-OFF every 1 second).
Front fog lamp relay (FOG) output		Allows fog lamp relay (FOG) to operate by switching operation ON-OFF at your option.

## Headlamp HI Does Not Illuminate (Both Sides)

EKS00CM1

### 1. CHECK COMBINATION SWITCH INPUT SIGNAL

Select "BCM" on CONSULT-II. With "HEAD LAMP" data monitor, make sure "HI BEAM SW" turns ON-OFF linked with operation of lighting switch.

**When lighting switch is in : HI BEAM SW ON  
HIGH position**

OK or NG

OK >> GO TO 2.

NG >> Check lighting switch. Refer to [LT-81, "Combination Switch Inspection"](#) .

DATA MONITOR	
MONITOR	
HI BEAM SW	ON

SKIA4193E

# HEADLAMP (FOR USA)

## 2. HEADLAMP ACTIVE TEST

1. Select "IPDM E/R" on CONSULT-II, and select "ACTIVE TEST" on "SELECT DIAG MODE" screen.
2. Select "EXTERNAL LAMPS" on "SELECT TEST ITEM" screen.
3. Touch "HI" on "ACTIVE TEST" screen.
4. Make sure headlamp high beam operates.

**Headlamp high beam should operate.**

OK or NG

- OK >> GO TO 3.  
NG >> GO TO 4.

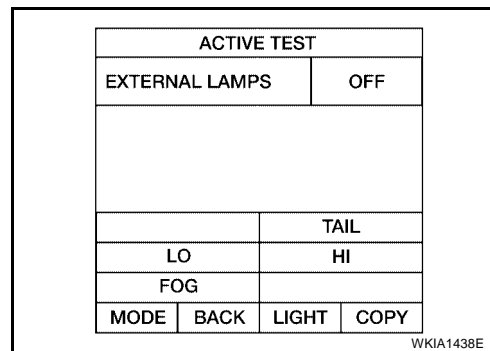

## 3. CHECK IPDM E/R

1. Select "IPDM E/R" on CONSULT-II, and select "DATA MONITOR" on "SELECT DIAG MODE" screen.
2. Make sure "HL LO REQ" and "HL HI REQ" turns ON when lighting switch is in HIGH position.

**When lighting switch is in HIGH position : HL LO REQ ON  
: HL HI REQ ON**

OK or NG

- OK >> Replace IPDM E/R. Refer to [PG-33, "Removal and Installation of IPDM E/R"](#) .
- NG >> Replace BCM. Refer to [BCS-26, "Removal and Installation"](#) .

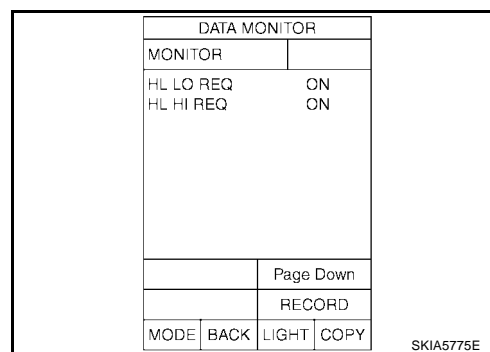

## 4. CHECK HEADLAMP INPUT SIGNAL

1. Turn ignition switch OFF.
2. Disconnect front combination lamp RH and LH (headlamp) connectors.
3. Select "IPDM E/R" on CONSULT-II, and select "ACTIVE TEST" on "SELECT DIAG MODE" screen.
4. Select "EXTERNAL LAMPS" on "SELECT TEST ITEM" screen.
5. Touch "HI" on "ACTIVE TEST" screen.
6. When headlamp high beam is operating, check voltage between front combination lamp RH and LH (headlamp) harness connector and ground.

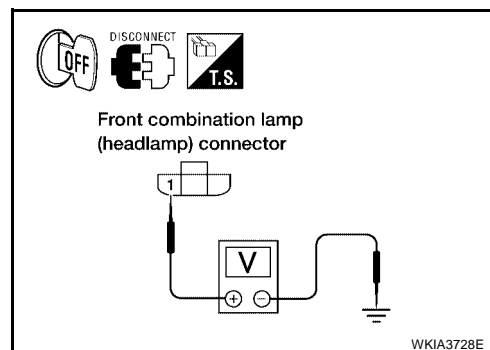

Front combination lamp (headlamp)		Terminal	(-)	Voltage
(+) Connector				
RH	E107	1	Ground	Battery voltage
LH	E11			

OK or NG

- OK >> GO TO 6.  
NG >> GO TO 5.

# HEADLAMP (FOR USA)

## 5. CHECK HEADLAMP CIRCUIT

1. Turn ignition switch OFF.
2. Disconnect IPDM E/R connector.
3. Check continuity between IPDM E/R harness connector E123 terminal 56 and front combination lamp RH (headlamp) harness connector E107 terminal 1.

**56 - 1** : Continuity should exist.

4. Check continuity between IPDM E/R harness connector E123 terminal 55 and front combination lamp LH (headlamp) harness connector E11 terminal 1.

**55 - 1** : Continuity should exist.

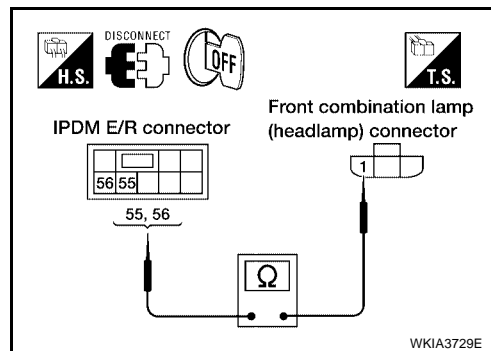

OK or NG

- OK >> Replace IPDM E/R. Refer to [PG-33, "Removal and Installation of IPDM E/R"](#).
- NG >> Repair harness or connector.

## 6. CHECK HEADLAMP GROUND

1. Check continuity between front combination lamp RH (headlamp) harness connector E107 terminal 2 and ground.

**2 - Ground** : Continuity should exist.

2. Check continuity between front combination lamp LH (headlamp) harness connector E11 terminal 2 and ground.

**2 - Ground** : Continuity should exist.

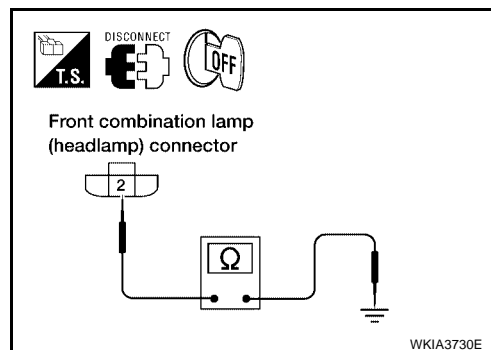

OK or NG

- OK >> Check front headlamp connector for damage or poor connection. Repair as necessary.
- NG >> Repair harness or connector.

## Headlamp HI Does Not Illuminate (One Side)

EKS00CM2

### 1. BULB INSPECTION

Inspect inoperative headlamp bulb.

OK or NG

- OK >> GO TO 2.
- NG >> Replace headlamp bulb. Refer to [LT-26, "HEADLAMP BULB"](#).

### 2. CHECK POWER TO HEADLAMP

1. Disconnect inoperative headlamp connector.
2. Turn the high beam headlamps ON.
3. Check voltage between inoperative headlamp terminal and ground.

Front combination lamp (headlamp)		Terminal	(-)	Voltage (Approx.)
(+) Connector				
RH	E107	1	Ground	Battery voltage
LH	E11			

OK or NG

- OK >> GO TO 3.
- NG >> GO TO 4.

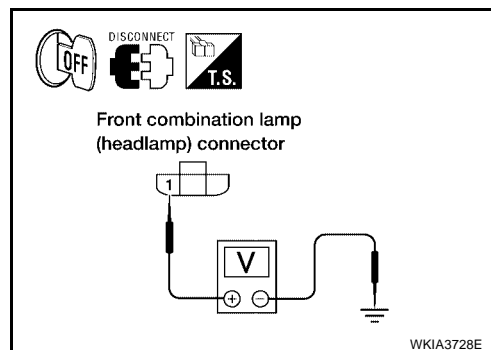

# HEADLAMP (FOR USA)

## 3. CHECK HEADLAMP GROUND

1. Turn the high beam headlamps OFF.
2. Check continuity between inoperative headlamp connector and ground.

Front combination lamp (headlamp)		Terminal	Ground	Continuity
Connector				
RH	E107	2	Ground	Yes
LH	E11			

### OK or NG

- OK >> Check headlamp connector for damage or poor connection. Repair as necessary.
- NG >> Repair open circuit in harness between inoperative headlamp and ground.

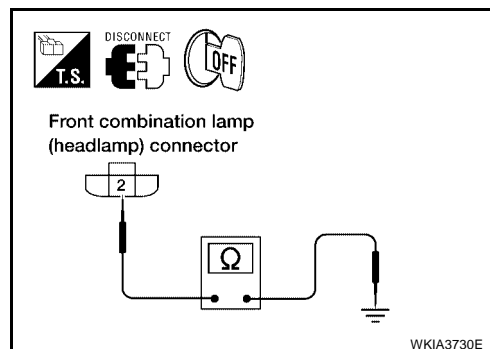

## 4. INSPECTION BETWEEN IPDM E/R AND HEADLAMPS

1. Disconnect IPDM E/R connector and inoperative headlamp connector.
2. Check continuity between harness connector terminals of IPDM E/R and harness connector terminals of inoperative headlamp.

IPDM E/R		Front combination lamp (headlamp)		Continuity
Connector	Terminal	Connector	Terminal	
E123	56	RH	E107	Yes
	55	LH	E11	

### OK or NG

- OK >> Replace IPDM E/R. Refer to [PG-33, "Removal and Installation of IPDM E/R"](#).
- NG >> Check for short circuits and open circuits in harness between IPDM E/R and headlamps. Repair as necessary.

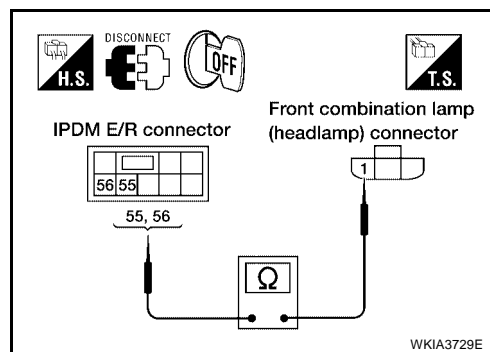

## High Beam Indicator Lamp Does Not Illuminate

EKS00CM3

### 1. BULB INSPECTION

Inspect CAN communication system. Refer to [LAN-22, "CAN COMMUNICATION"](#).

### OK or NG

- OK >> Replace combination meter. Refer to [IP-13, "COMBINATION METER"](#).
- NG >> Repair as necessary.

## Headlamp LO Does Not Illuminate (Both Sides)

EKS00CM4

### 1. CHECK COMBINATION SWITCH INPUT SIGNAL

Select "BCM" on CONSULT-II. With "HEAD LAMP" data monitor, make sure "HEAD LAMP SW 1" and "HEAD LAMP SW 2" turns ON-OFF linked with operation of lighting switch.

**When lighting switch is in 2ND position :**  
**HEAD LAMP SW 1 ON**  
**HEAD LAMP SW 2 ON**

### OK or NG

- OK >> GO TO 2.
- NG >> Check lighting switch. Refer to [LT-81, "Combination Switch Inspection"](#).

DATA MONITOR	
MONITOR	
HEAD LAMP SW1	ON
HEAD LAMP SW2	ON

SKIA4194E

# HEADLAMP (FOR USA)

## 2. HEADLAMP ACTIVE TEST

1. Select "IPDM E/R" on CONSULT-II, and select "ACTIVE TEST" on "SELECT DIAG MODE" screen.
2. Select "EXTERNAL LAMPS" on "SELECT TEST ITEM" screen.
3. Touch "LO" on "ACTIVE TEST" screen.
4. Make sure headlamp low beam operates.

**Headlamp low beam should operate.**

OK or NG

- OK >> GO TO 3.  
 NG >> GO TO 4.

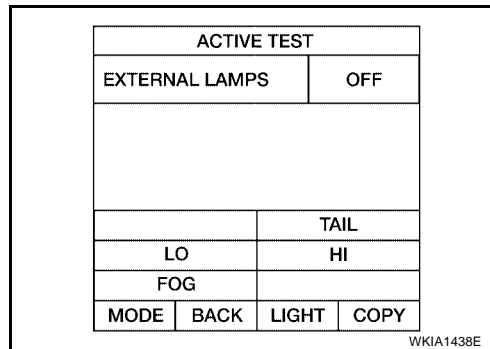

## 3. CHECK IPDM E/R

1. Select "IPDM E/R" on CONSULT-II, and select "DATA MONITOR" on "SELECT DIAG MODE" screen.
2. Make sure "HL LO REQ" turns ON when lighting switch is in 2ND position.

**When lighting switch is in 2ND position : HL LO REQ ON**

OK or NG

- OK >> Replace IPDM E/R. Refer to [PG-33, "Removal and Installation of IPDM E/R"](#) .
- NG >> Replace BCM. Refer to [BCS-26, "Removal and Installation"](#) .

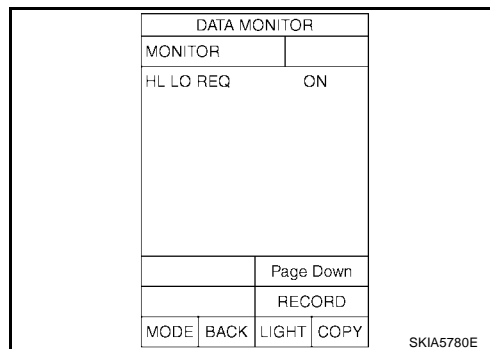

## 4. CHECK HEADLAMP INPUT SIGNAL

1. Turn ignition switch OFF.
2. Disconnect front combination lamp RH and LH (headlamp) connector.
3. Turn ignition switch ON.
4. Select "IPDM E/R" on CONSULT-II, and select "ACTIVE TEST" on "SELECT DIAG MODE" screen.
5. Select "EXTERNAL LAMPS" on "SELECT TEST ITEM" screen.
6. Touch "LO" on "ACTIVE TEST" screen.
7. When headlamp low beam is operating, check voltage between front combination lamp RH and LH (headlamp) harness connector and ground.

Front combination lamp (headlamp)		Terminal	(-)	Voltage
(+) Connector				
RH	E107	3	Ground	Battery voltage
LH	E11			

OK or NG

- OK >> GO TO 6.  
 NG >> GO TO 5.

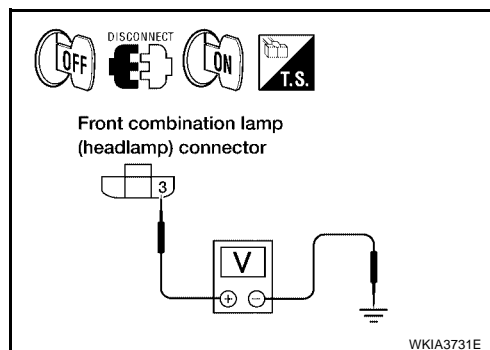

# HEADLAMP (FOR USA)

## 5. CHECK HEADLAMP CIRCUIT

1. Turn ignition switch OFF.
2. Disconnect IPDM E/R connector.
3. Check continuity between IPDM E/R harness connector E123 terminal 54 and front combination lamp RH (headlamp) harness connector E107 terminal 3.

**54 - 3 : Continuity should exist.**

4. Check continuity between IPDM E/R harness connector E123 terminal 52 and front combination lamp LH (headlamp) harness connector E11 terminal 3.

**52 - 3 : Continuity should exist.**

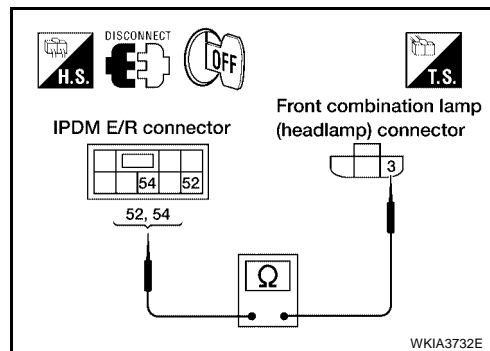

OK or NG

- OK >> Replace IPDM E/R. Refer to [PG-33, "Removal and Installation of IPDM E/R"](#).
- NG >> Repair harness or connector.

## 6. CHECK HEADLAMP GROUND

1. Turn ignition switch OFF.
2. Check continuity between front combination lamp RH (headlamp) harness connector E107 terminal 2 and ground.

**2 - Ground : Continuity should exist.**

3. Check continuity between front combination lamp LH (headlamp) harness connector E11 terminal 2 and ground.

**2 - Ground : Continuity should exist.**

OK or NG

- OK >> Check front combination lamp (headlamp) connector for damage or poor connection. Repair as necessary.
- NG >> Repair harness or connector.

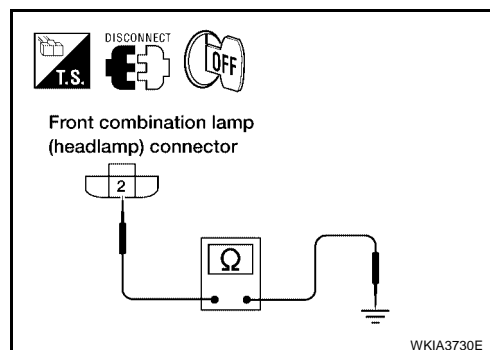

## Headlamp LO Does Not Illuminate (One Side)

EKS00CM5

### 1. BULB INSPECTION

Inspect inoperative headlamp bulb.

OK or NG

- OK >> GO TO 2.
- NG >> Replace headlamp bulb. Refer to [LT-26, "HEADLAMP BULB"](#).

# HEADLAMP (FOR USA)

## 2. CHECK POWER TO HEADLAMP

1. Disconnect inoperative headlamp connector.
2. Turn the low beam headlamps ON.
3. Check voltage between inoperative headlamp connector terminal and ground.

Front combination lamp (headlamp)		Terminal	(-)	Voltage (Approx.)
(+)				
Connector	Terminal	3	Ground	Battery voltage
RH	E107			
LH	E11			

OK or NG

- OK >> GO TO 3.  
 NG >> GO TO 4.

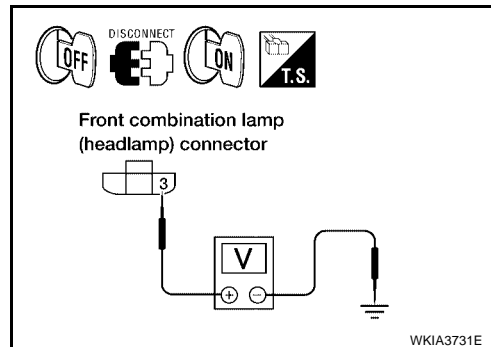

## 3. CHECK HEADLAMP GROUND

1. Turn the low beam headlamps OFF.
2. Check continuity between inoperative headlamp connector terminal and ground.

Front combination lamp (headlamp)		Terminal	Ground	Continuity
Connector	Terminal			
RH	E107	2	Ground	Yes
LH	E11			

OK or NG

- OK >> Check headlamp and IPDM E/R connector. Repair as necessary.  
 NG >> Repair open circuit in harness between inoperative headlamp and ground.

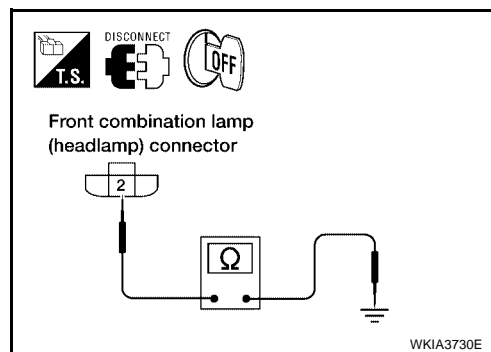

## 4. INSPECTION BETWEEN IPDM E/R AND HEADLAMPS

1. Disconnect IPDM E/R connector.
2. Check continuity between harness connector terminals of IPDM E/R and harness connector terminals of inoperative headlamp.

IPDM E/R		Front combination lamp (headlamp)		Continuity
Connector	Terminal	Connector	Terminal	
E123	54	RH	E107	Yes
	52	LH	E11	

OK or NG

- OK >> Replace IPDM E/R. Refer to [PG-33, "Removal and Installation of IPDM E/R"](#) .  
 NG >> Check for short circuits and open circuits in harness between IPDM E/R and headlamps. Repair as necessary.

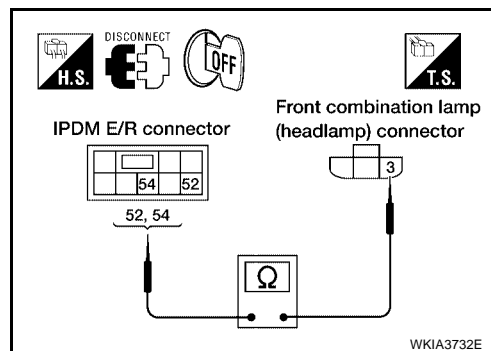

# HEADLAMP (FOR USA)

EKS00CM6

## Headlamps Do Not Turn OFF

### 1. CHECK COMBINATION SWITCH INPUT SIGNAL

Select "BCM" on CONSULT-II. With "HEAD LAMP" data monitor, make sure "HEAD LAMP SW 1" and "HEAD LAMP SW 2" turns ON-OFF linked with operation of lighting switch.

**When lighting switch is in OFF position : HEAD LAMP SW 1 OFF  
: HEAD LAMP SW 2 OFF**

OK or NG

- OK >> Replace IPDM E/R. Refer to [PG-33, "Removal and Installation of IPDM E/R"](#).
- NG >> GO TO 2.

DATA MONITOR	
MONITOR	
HEAD LAMP SW 1	OFF
HEAD LAMP SW 2	OFF

SKIA5200E

### 2. CHECK LIGHTING SWITCH

Check lighting switch. Refer to [LT-81, "Combination Switch Inspection"](#).

OK or NG

- OK >> GO TO 3.
- NG >> Replace lighting switch. Refer to [LT-76, "Removal and Installation"](#).

### 3. CHECKING CAN COMMUNICATIONS BETWEEN BCM AND IPDM E/R

Select "BCM" on CONSULT-II and perform self-diagnosis for BCM.

Display of self-diagnosis results

- NO DTC>> Replace IPDM E/R. Refer to [PG-33, "Removal and Installation of IPDM E/R"](#).
- CAN COMM CIRCUIT>> Refer to [BCS-19, "CAN Communication Inspection Using CONSULT-II \(Self-Diagnosis\)"](#).

SELF-DIAG RESULTS			
DTC RESULTS			TIME
CAN COMM CIRCUIT [U1000]			PAST
ERASE		PRINT	
MODE	BACK	LIGHT	COPY

SKIA1039E



# HEADLAMP (FOR USA)

## Aiming Adjustment

EKS00BP2

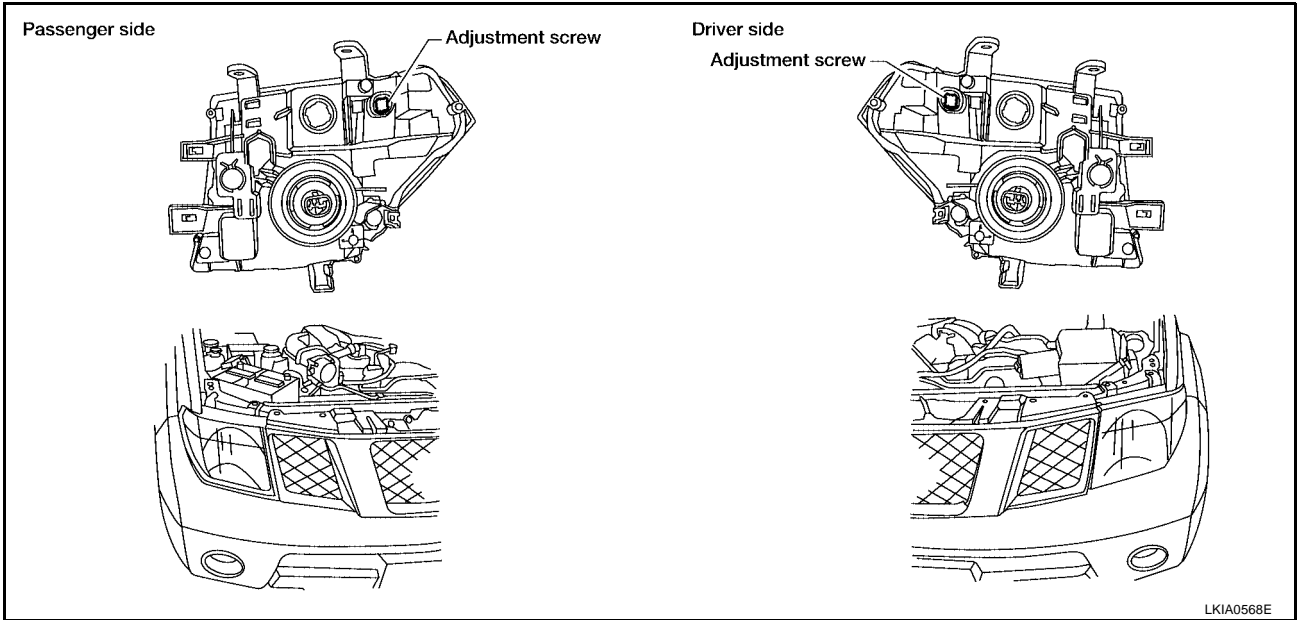

### NOTE:

- For headlamp aiming details, refer to the regulations in your area.
- If vehicle front body has been repaired or the headlamp assembly has been replaced, check headlamp aiming.
- Before performing aiming adjustment, check the following:
  - Confirm headlamp aiming switch is set to "0" (zero) position.
  - Ensure all tires are inflated to correct pressure.
  - Place vehicle and screen on level surface.
  - Ensure there is no load in vehicle other than the driver (or equivalent weight placed in driver's position). Coolant and engine oil filled to correct level, and fuel tank full.
  - Confirm spare tire, jack and tools are properly stowed.
  - Aim each headlamp individually and ensure other headlamp beam pattern is blocked from screen.
  - Use adjusting screw to perform aiming adjustment

### LOW BEAM AND HIGH BEAM

#### CAUTION:

Do not tighten adjustment screw beyond a torque of 1.67 N-m (17 kg-cm, 14.8 in-lb) or damage may occur.

#### NOTE:

By regulation, no means for horizontal aim adjustment is provided from the factory; only vertical aim is adjustable.

1. Turn headlamp low beam on.
2. Use adjustment screw to perform aiming adjustment.
3. Adjust beam pattern until cut-off line (top edge of illumination area) is positioned at same height off ground as bulb center (on H-line). Measure cut-off line within distance A on H-line. See aiming chart below.
  - Basic illuminating area for adjustment should be within the range shown on the aiming chart. Adjust headlamps accordingly.

# HEADLAMP (FOR USA)

## HEADLAMP AIMING

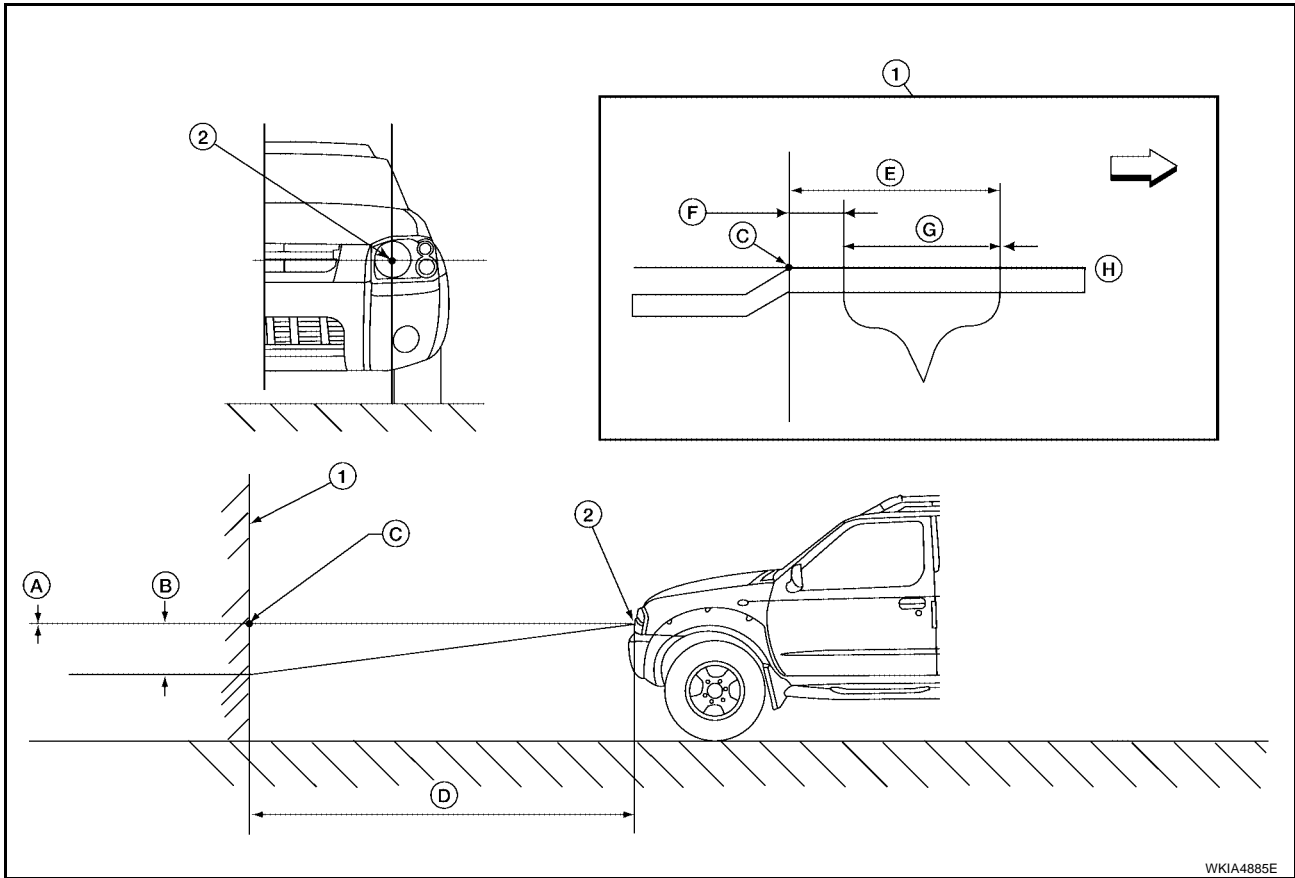

WKIA4885E

- |   |   |   |  |   |   |
|---|---|---|--|---|---|
| 1 | Adjustment screen   | 2 | Headlamp bulb center (HV point)  | A | Minimum acceptable vertical aim dimension (see aiming chart)    |
| B | Maximum acceptable vertical aim dimension (see aiming chart)                        | C | H-V point  | D | Distance of headlamp aiming screen from vehicle 7.62 m (25 ft.) |
| E | Maximum aim evaluation distance from vertical center on aiming screen 399mm (3° R). | F | Minimum aim evaluation distance from vertical center on aiming screen 133 mm (1°R) | G | Aim evaluation area   |
| H | Horizontal aiming evaluation line.  | ← | Right  |   |   |

### Aiming Chart

A (Minimum acceptable vertical aim dimension)	-3.3 mm (0.13 in)	0.025° up
B (Maximum acceptable vertical aim dimension)	36.6 mm (1.44 in)	0.275° down

### Bulb Replacement

EKS00HM3

#### CAUTION:

Leaving bulb removed from the headlamp housing for a long period of time can deteriorate the performance of the lens and reflector (dirt, clouding). Always prepare a new bulb and have it on hand when replacing a bulb.

### HEADLAMP BULB

#### Removal

#### CAUTION:

Grasp only the plastic base when handling headlamp bulb. Never touch the glass envelope.

1. Turn front headlamp switch OFF.
2. Disconnect the electrical connector.
3. Rotate the headlamp bulb retaining ring counterclockwise and remove.
4. Pull the headlamp bulb straight out from the headlamp assembly.

# HEADLAMP (FOR USA)

## Installation

Installation is in the reverse order of removal.

### CAUTION:

After installing bulb, be sure to install the bulb socket and plastic cap securely to ensure watertightness.

## FRONT TURN SIGNAL/PARKING LAMP

### Removal

1. Turn the bulb socket counterclockwise to unlock it.
2. Pull the bulb to remove it from the socket.

### Installation

Installation is in the reverse order of removal.

### CAUTION:

After installing bulb, be sure to install the bulb socket and plastic cap securely to ensure watertightness.

## FRONT SIDE MARKER LAMP

### Removal

1. Turn the bulb socket counterclockwise to unlock it.
2. Pull the bulb to remove it from the socket.

### Installation

Installation is in the reverse order of removal.

### CAUTION:

After installing bulb, be sure to install the bulb socket securely for watertightness.

## Removal and Installation FRONT COMBINATION LAMP

EKS00HM4

### Removal

1. Position front fender protector aside. Refer to [EI-22, "FENDER PROTECTOR"](#).
2. Remove the front bumper upper valance. Refer to [EI-15, "PLASTIC BUMPER"](#).
3. Remove the front combination lamp bolts.

4. Disconnect the front combination lamp connector and remove front combination lamp.

### Installation

Installation is in the reverse order of removal.

**: 6.0 N-m (0.61 kg-m, 53 in-lb)**

A

B

C

D

E

F

G

H

I

J

LT

L

M

# HEADLAMP (FOR USA)

## Disassembly and Assembly

EKS00BP5

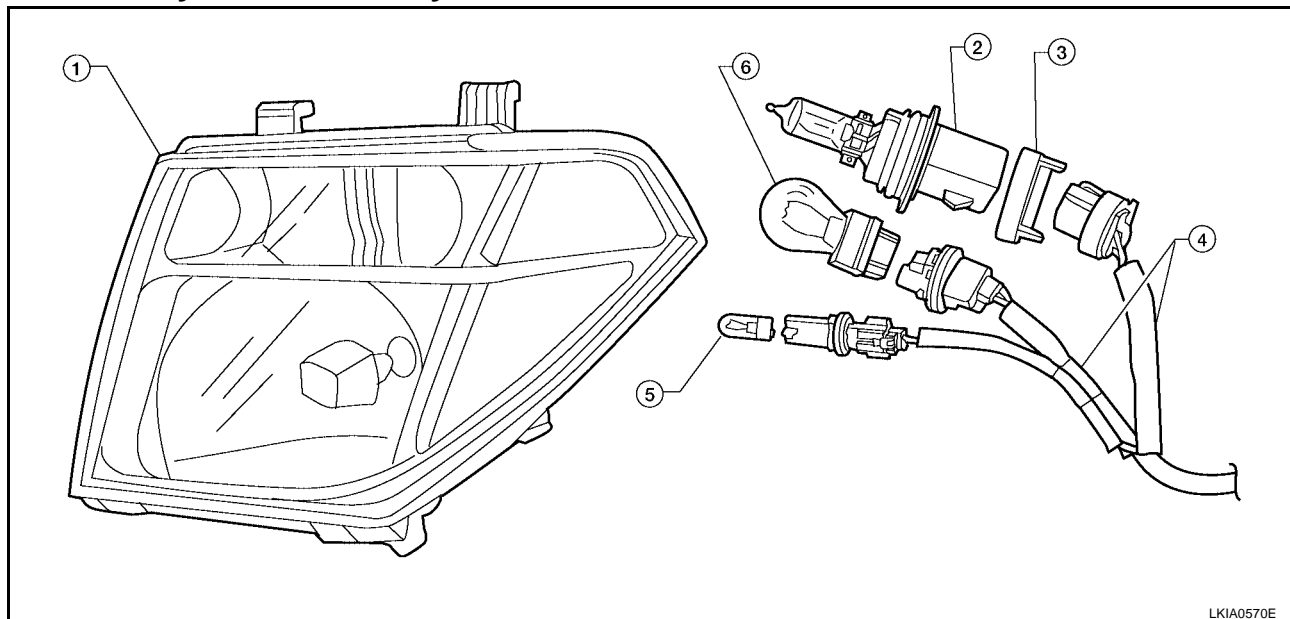

- |                            |                                |  |
|----------------------------|--------------------------------|--|
| 1. Headlamp assembly       | 2. Headlamp bulb               | 3. Headlamp bulb retaining ring        |
| 4. Wiring harness assembly | 5. Front side marker lamp bulb | 6. Front turn signal/parking lamp bulb |

### DISASSEMBLY

#### CAUTION:

Leaving bulb removed from the headlamp housing for a long period of time can deteriorate the performance of the lens and reflector (dirt, clouding). Always prepare a new bulb and have it on hand when replacing a bulb.

1. Rotate headlamp bulb retaining ring counterclockwise and remove.

#### CAUTION:

Grasp only the plastic base when handling headlamp bulb. Never touch the glass envelope.

2. Turn front turn signal/parking lamp bulb socket counterclockwise to unlock and remove socket.
3. Turn front side marker lamp bulb socket counterclockwise to unlock and remove socket.

### ASSEMBLY

Installation is in the reverse order of removal.

#### CAUTION:

After installing bulb, be sure to install the bulb socket and plastic cap securely to ensure watertightness.

# HEADLAMP (FOR CANADA) - DAYTIME LIGHT SYSTEM -

## HEADLAMP (FOR CANADA) - DAYTIME LIGHT SYSTEM -

PFP:26010

### Component Parts and Harness Connector Location

EKS00BP6

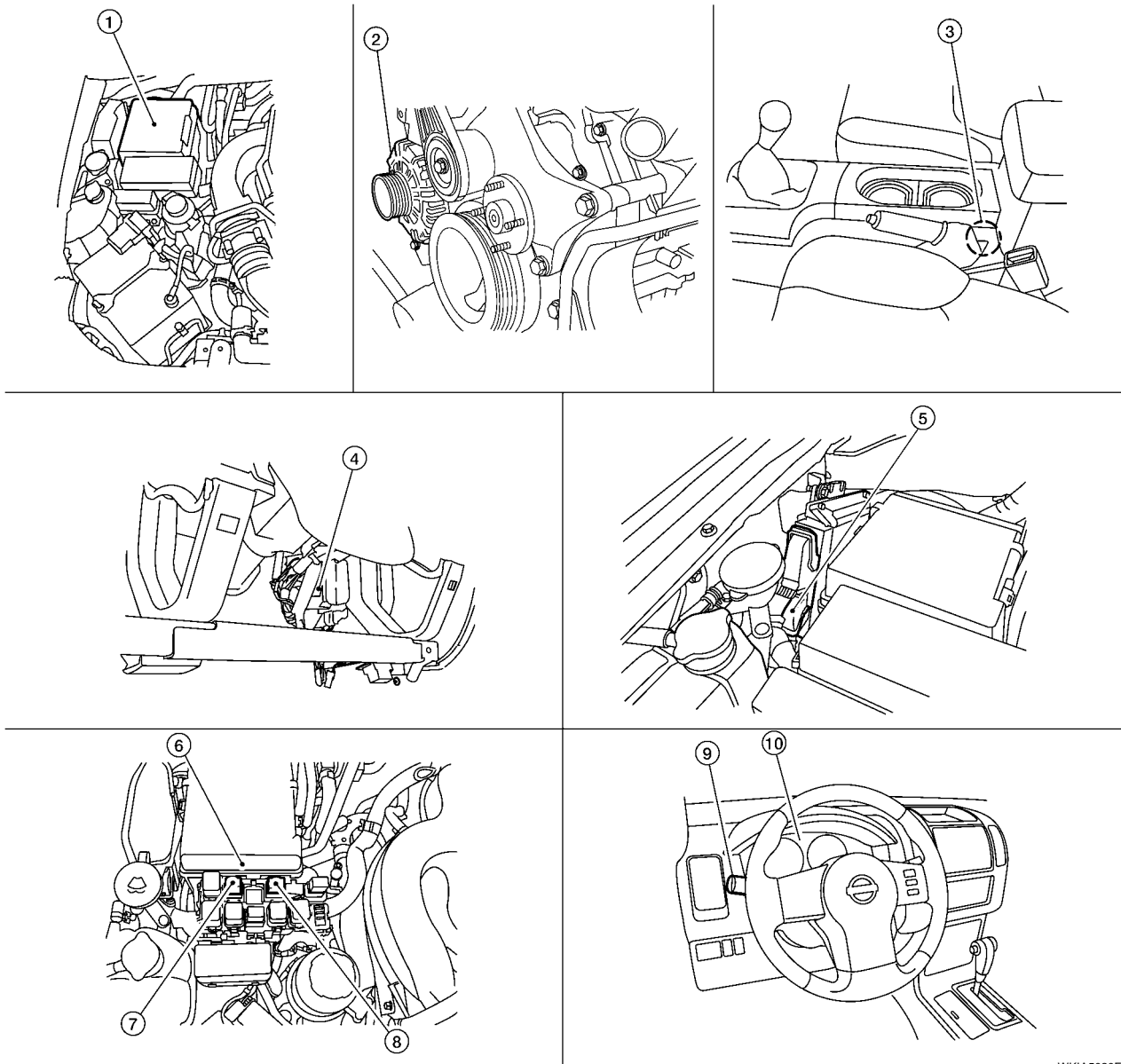

A  
B  
C  
D  
E  
F  
G  
H  
I  
J  
LT  
L  
M

WKIA5020E

- |   |  |  |
|---|--|--|
| 1. IPDM E/R<br>E122, E123, E124                                     | 2. Generator<br>E205                           | 3. Parking brake switch<br>B84                 |
| 4. BCM<br>M18, M20<br>(view with lower instrument panel LH removed) | 5. ECM<br>E16<br>(view with ECM cover removed) | 6. Fuse and relay box                          |
| 7. Daytime light relay 1<br>E103                                    | 8. Daytime light relay 2<br>E104               | 9. Combination switch (lighting switch)<br>M28 |
| 10. Combination meter<br>M24  |  |  |

### System Description

EKS00CM7

Daytime light system turns on daytime light lamps while driving. Daytime light lamps are not turned on if engine is activated with parking brake on. Take off parking brake to turn on daytime light lamps. The lamps turn off when lighting switch is in the 2ND position or AUTO position (Headlamp is "ON") and when lighting switch is in the PASSING position. (Daytime light lamps are not turned off only by parking brake itself.) A parking brake signal and engine run or stop signal are sent to BCM (body control module) by CAN communication line.

# HEADLAMP (FOR CANADA) - DAYTIME LIGHT SYSTEM -

---

## OUTLINE

Power is supplied at all times

- through 10A fuse [No. 19, located in the fuse block (J/B)]
- to combination meter terminal 3, and
- through 20A fuse [No. 53, located in the IPDM E/R (intelligent power distribution module engine room)]
- to CPU (central processing unit) of IPDM E/R, and
- to ignition relay, located in the IPDM E/R, and
- to headlamp high relay, located in the IPDM E/R, and
- to headlamp low relay, located in the IPDM E/R, and
- through 50A fusible link (letter **g**, located in the fuse and fusible link box)
- to BCM terminal 70, and
- through 10A fuse (No. 45, located in the IPDM E/R)
- to daytime light relay 1 terminals 2 and 5.

When the ignition switch is in ON or START position, power is supplied

- to ignition relay, located in the IPDM E/R, and
- through 10A fuse [No. 14, located in the fuse block (J/B)]
- to combination meter terminal 16, and
- through 10A fuse [No. 1, located in the fuse block (J/B)]
- to BCM terminal 38.

Ground is supplied

- to BCM terminal 67 and
- to combination meter terminals 13 and 23
- through grounds M57, M61 and M79, and
- to IPDM E/R terminals 38 and 59
- through grounds E9, E15 (all) and E24 (VQ40DE engine only).

## Low Beam Operation

With the lighting switch in 2ND position, the BCM receives input requesting the headlamps to illuminate. This input is communicated to the IPDM E/R across the CAN communication lines. The CPU of the IPDM E/R controls the headlamp low relay coil. When energized, this relay directs power

- through 15A fuse (No. 41, located in the IPDM E/R)
- through IPDM E/R terminal 54
- to front combination lamp RH (headlamp) terminal 3, and
- through 15A fuse (No. 40, located in the IPDM E/R)
- through IPDM E/R terminal 52
- to daytime light relay 2 terminals 2 and 5, and
- through daytime light relay 2 terminal 3
- to front combination lamp LH (headlamp) terminal 3.

Ground is supplied

- to front combination lamp RH (headlamp) terminal 2
- to daytime light relay 1 terminal 4
- to daytime light relay 2 terminal 1
- through grounds E9, E15 (all) and E24 (VQ40DE engine only).

When the CPU of the IPDM E/R energizes the headlamp low relay, it de-energizes daytime relay 1. When de-energized, this relay supplies ground

- to front combination lamp LH (headlamp) terminal 2
- through daytime light relay 1 terminal 3.

With power and ground supplied, low beam headlamps illuminate.

# HEADLAMP (FOR CANADA) - DAYTIME LIGHT SYSTEM -

## High Beam Operation/Flash-to-Pass Operation

With the lighting switch in 2ND position and placed in HIGH or PASS position, the BCM receives input requesting the headlamp high beams to illuminate. This input is communicated to the IPDM E/R across the CAN communication lines. The CPU of the combination meter controls the ON/OFF status of the HIGH BEAM indicator. The CPU of the IPDM E/R controls the headlamp high relay coil. When energized, this relay directs power

- through 10A fuse (No. 34, located in the IPDM E/R)
- through IPDM E/R terminal 56
- to front combination lamp RH (headlamp) terminal 1, and
- through 10A fuse (No. 35, located in the IPDM E/R)
- through IPDM E/R terminal 55
- to front combination lamp LH (headlamp) terminal 1.

Ground is supplied

- to front combination lamp RH (headlamp) terminal 2, and
- to daytime light relay 1 terminal 4, and
- to daytime light relay 2 terminal 1
- through grounds E9, E15 (all) and E24 (VQ40DE engine only).

When the CPU of the IPDM E/R energizes the headlamp high relay, it de-energizes daytime relay 1. When de-energized, this relay supplies ground

- to front combination lamp LH (headlamp) terminal 2
- through daytime light relay 1 terminal 3.

With power and ground supplied, the high beam headlamps illuminate.

## DAYTIME LIGHT OPERATION

With the engine running, the lighting switch in the OFF or 1ST position and parking brake released, the IPDM E/R receives input requesting the daytime lights illuminate. This input is communicated across the CAN communication lines. The CPU of the IPDM E/R controls daytime light relay 1 which supplies ground

- to daytime light relay 1 terminal 1
- through IPDM E/R terminal 44.

When energized, daytime light relay 1 directs power

- through daytime light relay 1 terminal 3
- through front combination lamp LH (headlamp) terminal 2
- through front combination lamp LH (headlamp) terminal 1
- through IPDM E/R terminal 55
- through 10A fuse (No. 35, located in the IPDM E/R)
- through 10A fuse (No. 34, located in the IPDM E/R)
- through IPDM E/R terminal 56
- to front combination lamp RH (headlamp) terminal 1.

Ground is supplied

- to front combination lamp RH (headlamp) terminal 2
- through grounds E9, E15 (all) and E24 (VQ40DE engine only).

With power and ground supplied, the daytime lights illuminate. The high beam headlamps are now wired in series and illuminate at a reduced intensity.

## COMBINATION SWITCH READING FUNCTION

Refer to [BCS-3, "COMBINATION SWITCH READING FUNCTION"](#) .

## AUTO LIGHT OPERATION

For auto light operation, refer to [LT-40, "System Description"](#) .

## CAN Communication System Description

Refer to [LAN-22, "CAN COMMUNICATION"](#) .

EKS00BP8

# HEADLAMP (FOR CANADA) - DAYTIME LIGHT SYSTEM -

EKS00BP9

## Schematic

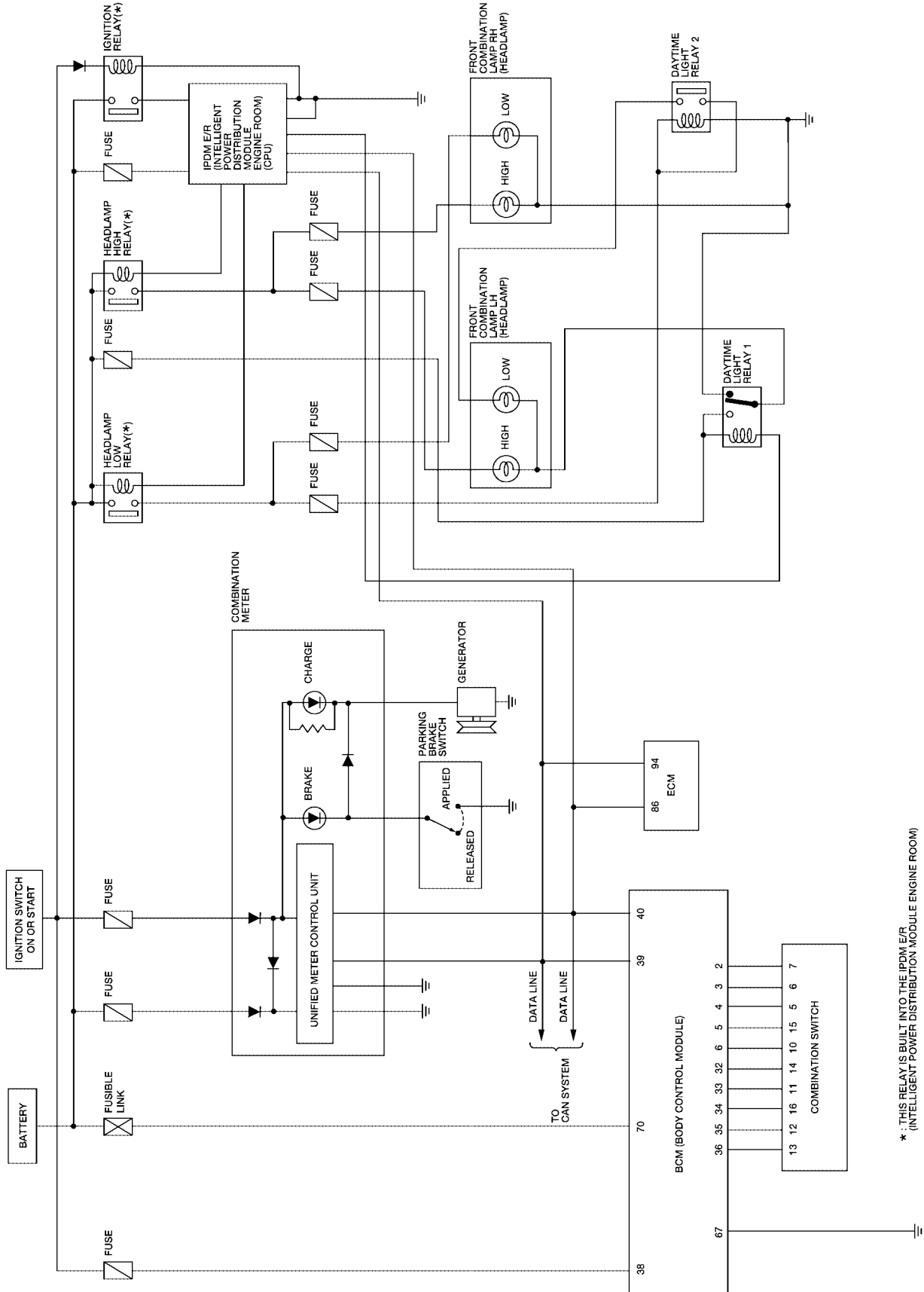

\* - THIS RELAY IS BUILT INTO THE IPDM E/R (INTELLIGENT POWER DISTRIBUTION MODULE ENGINE ROOM)

WKWA4350E



# HEADLAMP (FOR CANADA) - DAYTIME LIGHT SYSTEM -

## Wiring Diagram — DTRL —

EKS00BPA

### LT-DTRL-01

▬ : DATA LINE

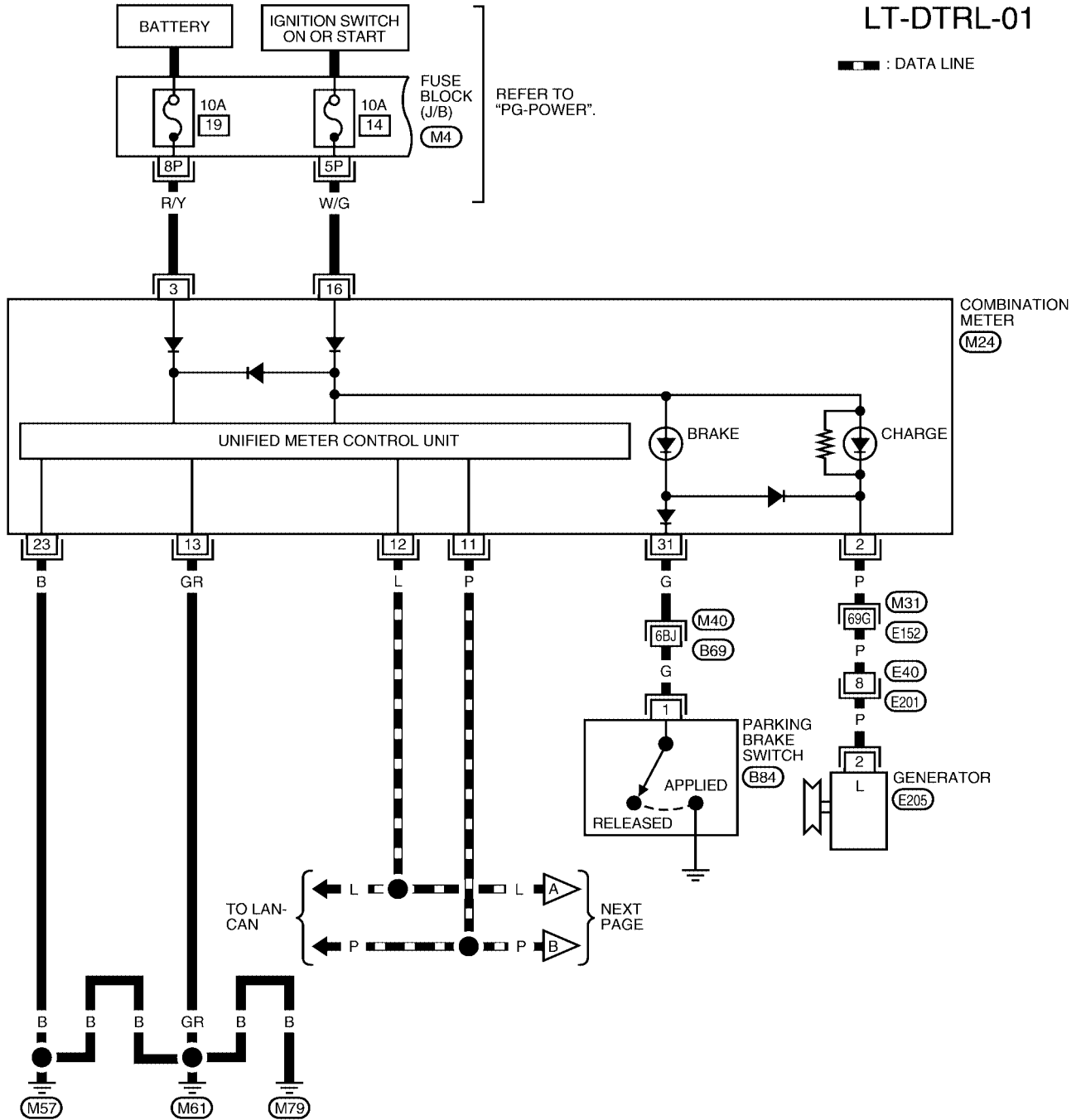

A  
B  
C  
D  
E  
F  
G  
H  
I  
J  
LT  
L  
M

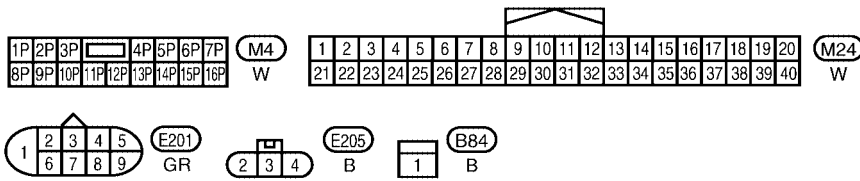

REFER TO THE FOLLOWING.  
 (M31), (M40) - SUPER  
 MULTIPLE JUNCTION (SMJ)

WKWA4351E

# HEADLAMP (FOR CANADA) - DAYTIME LIGHT SYSTEM -

LT-DTRL-02

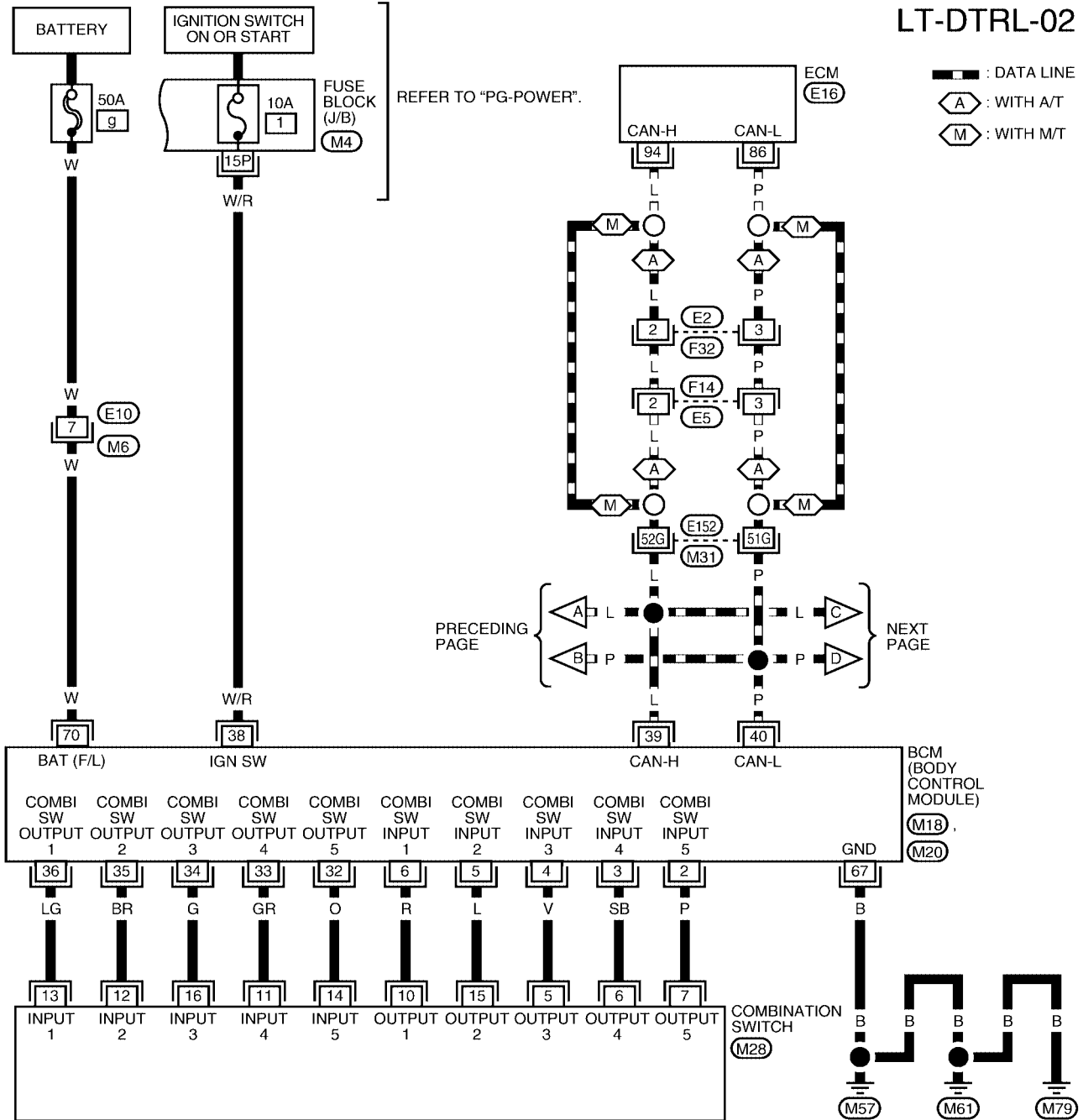

— : DATA LINE  
 (A) : WITH A/T  
 (M) : WITH M/T

PRECEDING PAGE → [A] L, [B] P → [C] L, [D] P → NEXT PAGE

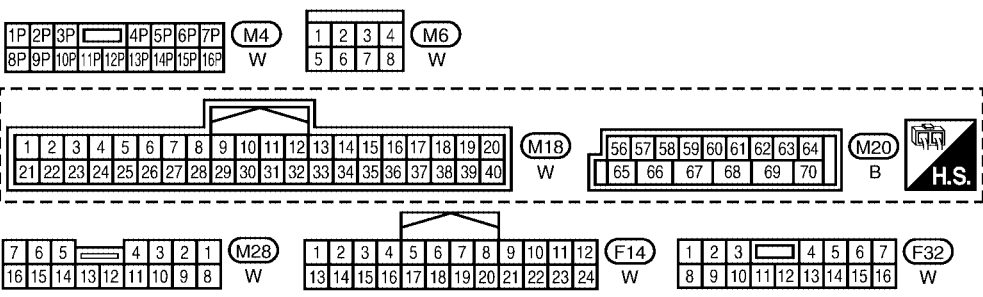

REFER TO THE FOLLOWING.  
 (E16) - ELECTRICAL UNITS  
 (M31) - SUPER MULTIPLE JUNCTION (SMJ)

WKWA4352E

# HEADLAMP (FOR CANADA) - DAYTIME LIGHT SYSTEM -

LT-DTRL-03

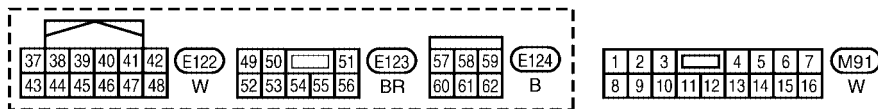
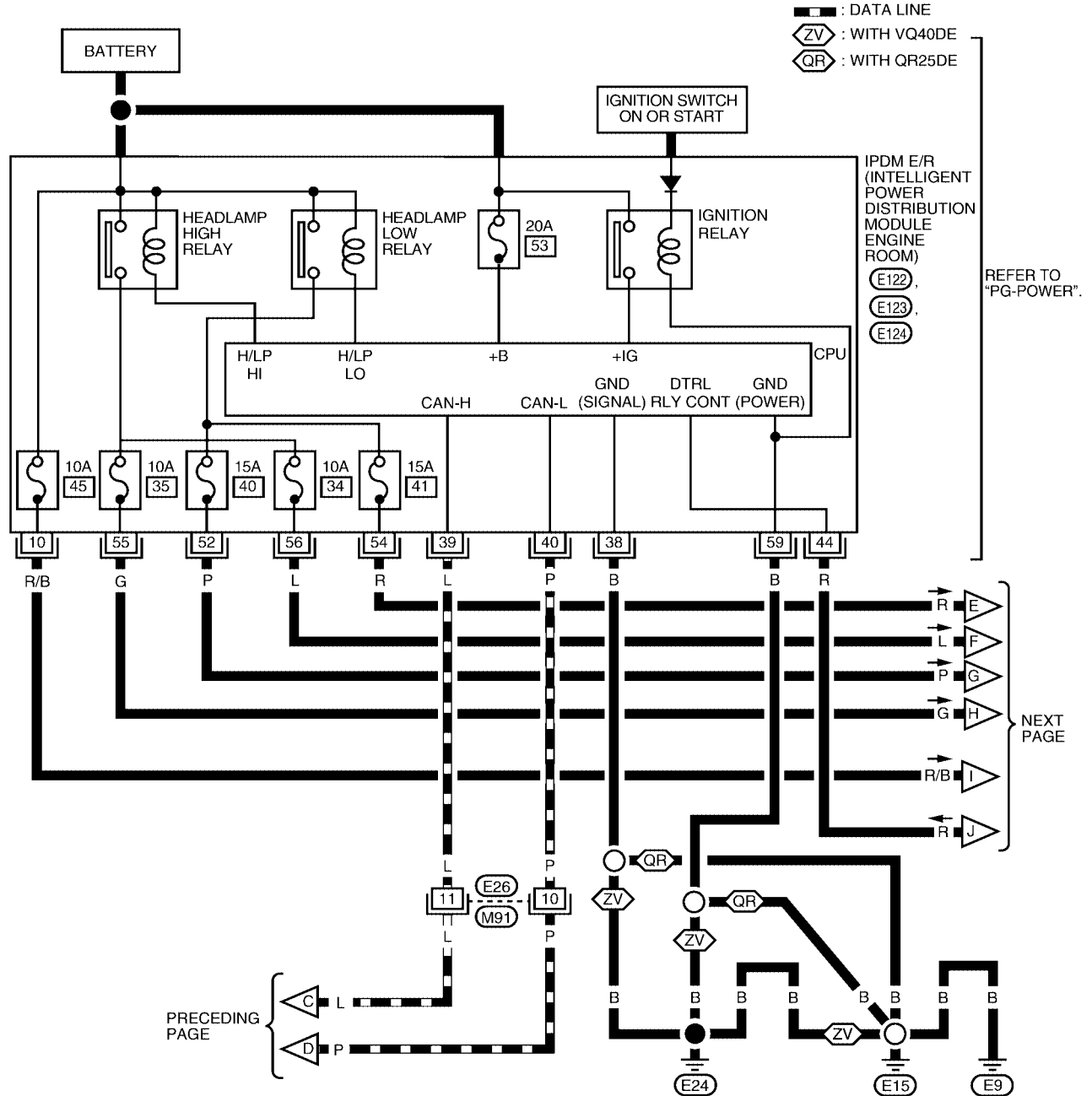

# HEADLAMP (FOR CANADA) - DAYTIME LIGHT SYSTEM -

LT-DTRL-04

ZV: WITH VQ40DE

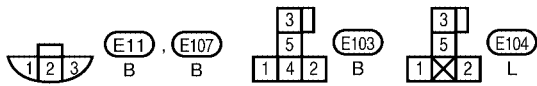
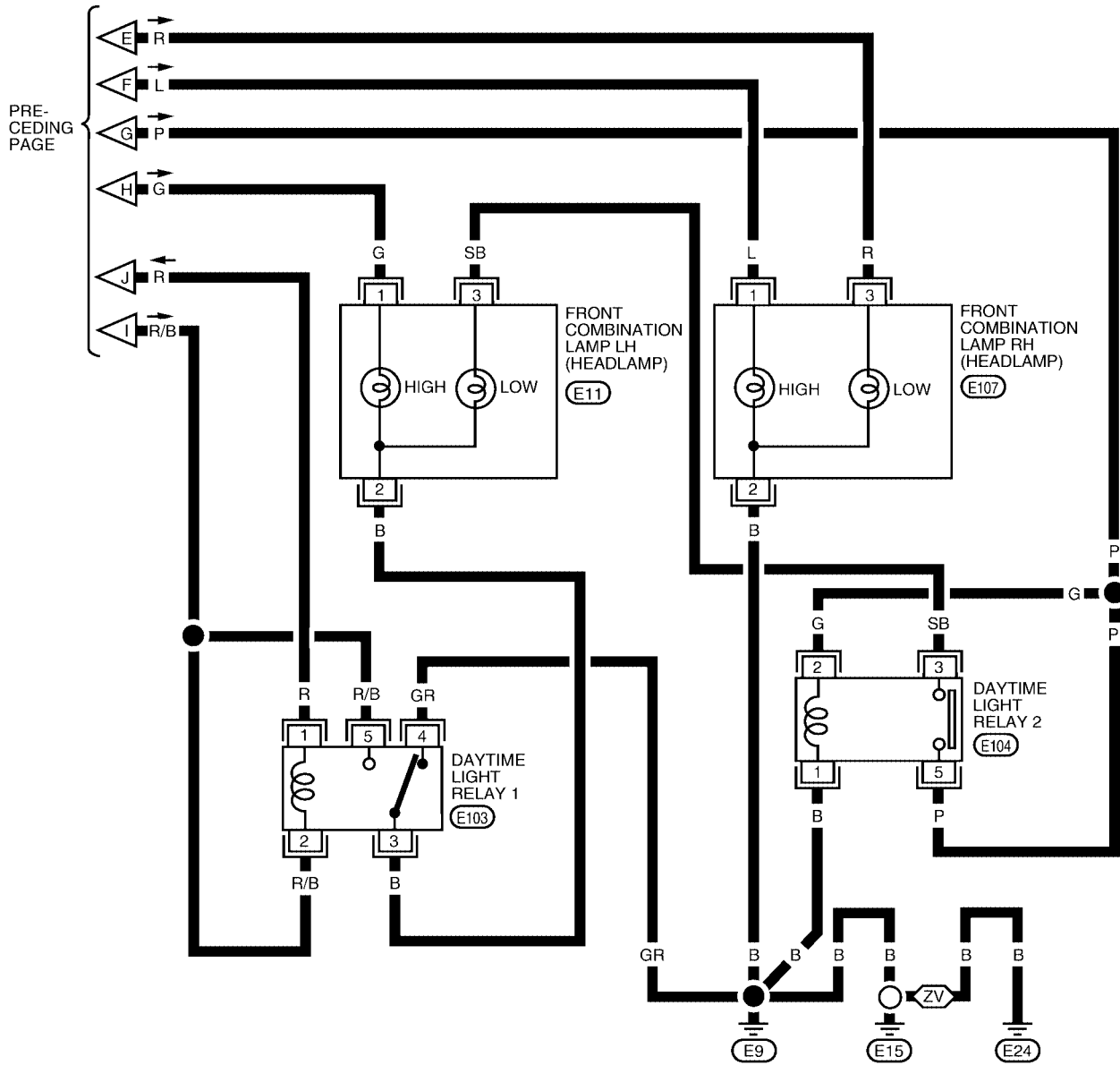

WKWA2871E

# HEADLAMP (FOR CANADA) - DAYTIME LIGHT SYSTEM -

## Terminals and Reference Values for BCM

EKS00CM8

Refer to [BCS-12, "Terminals and Reference Values for BCM"](#) .

## How to Proceed With Trouble Diagnosis

EKS00CM9

1. Confirm the symptom or customer complaint.
2. Understand operation description and function description. Refer to [LT-29, "System Description"](#) .
3. Perform the Preliminary Check. Refer to [LT-12, "Preliminary Check"](#) .
4. Check symptom and repair or replace the cause of malfunction.
5. Does the headlamp operate normally? If YES: GO TO 6. If NO: GO TO 4.
6. Inspection End.

## Preliminary Check

EKS00HM5

### CHECK BCM CONFIGURATION

#### 1. CHECK BCM CONFIGURATION

Confirm BCM configuration for "DTRL" is set to "WITH". Refer to [BCS-20, "READ CONFIGURATION PROCEDURE"](#) .

OK or NG

- OK >> Continue preliminary check. Refer to [LT-12, "CHECK POWER SUPPLY AND GROUND CIRCUIT"](#) .
- NG >> Change BCM configuration for "DTRL" to "WITH". Refer to [BCS-22, "WRITE CONFIGURATION PROCEDURE"](#) .

## INSPECTION FOR POWER SUPPLY AND GROUND CIRCUIT

Refer to [BCS-16, "BCM Power Supply and Ground Circuit Check"](#) .

## INSPECTION PARKING BRAKE SWITCH CIRCUIT

#### 1. CHECK BRAKE INDICATOR

1. Turn ignition switch ON.
2. Apply parking brake.
3. Release parking brake.

**Brake indicator in combination meter should illuminate when parking brake is applied and turn OFF when released.**

OK or NG

- OK >> Inspection End.
- NG >> GO TO 2.

#### 2. CHECK PARKING BRAKE SWITCH SIGNAL

1. Disconnect parking brake switch connector.
2. Turn ignition switch ON.
3. Check voltage between parking brake switch harness connector B84 terminal 1 and ground.

**1 - Ground : Battery voltage should exist.**

OK or NG

- OK >> Replace parking brake switch.
- NG >> GO TO 3.

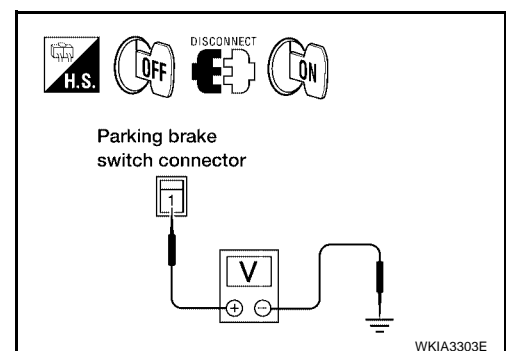

# HEADLAMP (FOR CANADA) - DAYTIME LIGHT SYSTEM -

## 3. CHECK PARKING BRAKE SWITCH CIRCUIT

1. Turn ignition switch OFF.
2. Disconnect combination meter connector.
3. Check continuity between combination meter harness connector M24 terminal 31 and parking brake switch harness connector B84 terminal 1.

**1 - 31 : Continuity should exist.**

OK or NG

OK >> Replace combination meter. Refer to [IP-13, "COMBINATION METER"](#).

NG >> Repair harness or connector.

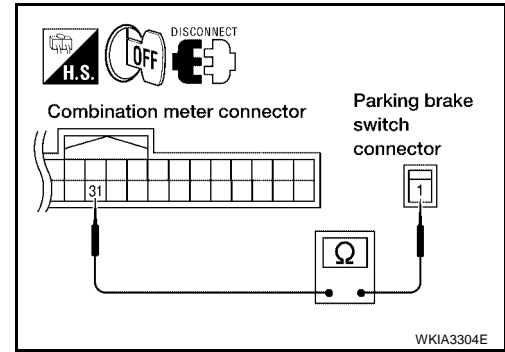

EKS00CMB

## CONSULT-II Functions

Refer to [LT-12, "CONSULT-II Function \(BCM\)"](#).

Refer to [LT-15, "CONSULT-II Function \(IPDM E/R\)"](#).

## Daytime Light Control Does Not Operate Properly (Normal Headlamps Operate Properly)

EKS00CMC

### 1. CHECK DAYTIME LIGHT RELAY 1 POWER SUPPLY CIRCUIT

1. Remove daytime light relay 1.
2. Check voltage between daytime light relay 1 harness connector E103 terminals 2, 5 and ground.

**2, 5 - Ground : Battery voltage should exist.**

OK or NG

OK >> GO TO 2.

NG >> Repair harness or connector.

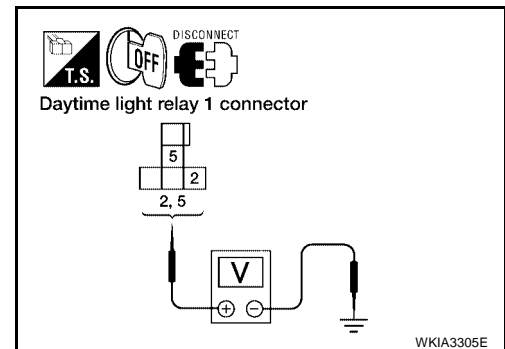

### 2. CHECK DAYTIME LIGHT RELAY 1

1. Apply battery voltage to daytime light relay 1 terminal 2 and ground terminal 1.
2. Check continuity between terminals 3 and 5.

**3 - 5 : Continuity should exist.**

OK or NG

OK >> GO TO 3.

NG >> Replace daytime light relay 1.

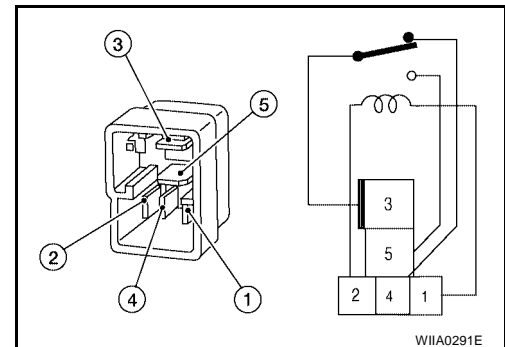

# HEADLAMP (FOR CANADA) - DAYTIME LIGHT SYSTEM -

## 3. CHECK INPUT SIGNAL

1. Connect daytime light relay 1.
2. Start engine and release parking brake. Headlamp switch OFF.
3. Select "IPDM E/R" on CONSULT-II. With data monitor, make sure "DTRL REQ" turns ON-OFF linked with operation of parking brake switch.

**Parking brake ON : DTRL REQ ON**  
**Parking brake OFF : DTRL REQ OFF**

OK or NG

OK >> Replace IPDM E/R. Refer to [PG-33, "Removal and Installation of IPDM E/R"](#) .

NG >> GO TO 4.

DATA MONITOR			
MONITOR			
DTRL REQ		OFF	
		RECORD	
MODE	BACK	LIGHT	COPY

WKIA1449E

## 4. CHECKING CAN COMMUNICATIONS

Select "BCM" on CONSULT-II and perform self-diagnosis for BCM.

Displayed self-diagnosis results

NO DTC>>Replace BCM. Refer to [BCS-26, "Removal and Installation"](#) .

CAN COMM CIRCUIT>> Check BCM CAN communication system.  
Refer to [BCS-19, "CAN Communication Inspection Using CONSULT-II \(Self-Diagnosis\)"](#) .

SELF-DIAG RESULTS			
DTC RESULTS		TIME	
CAN COMM CIRCUIT [U1000]		PAST	
ERASE		PRINT	
MODE	BACK	LIGHT	COPY

SKIA1039E

### Aiming Adjustment

Refer to [LT-25, "Aiming Adjustment"](#) .

### Bulb Replacement

Refer to [LT-26, "Bulb Replacement"](#) .

### Removal and Installation

Refer to [LT-27, "Removal and Installation"](#) .

### Disassembly and Assembly

Refer to [LT-28, "Disassembly and Assembly"](#) .

EKS00BPG

EKS00BPH

EKS00BPI

EKS00BPJ

A  
B  
C  
D  
E  
F  
G  
H  
I  
J  
LT  
L  
M

# AUTO LIGHT SYSTEM

## AUTO LIGHT SYSTEM

PF2:28491

### Component Parts and Harness Connector Location

EKS00BPK

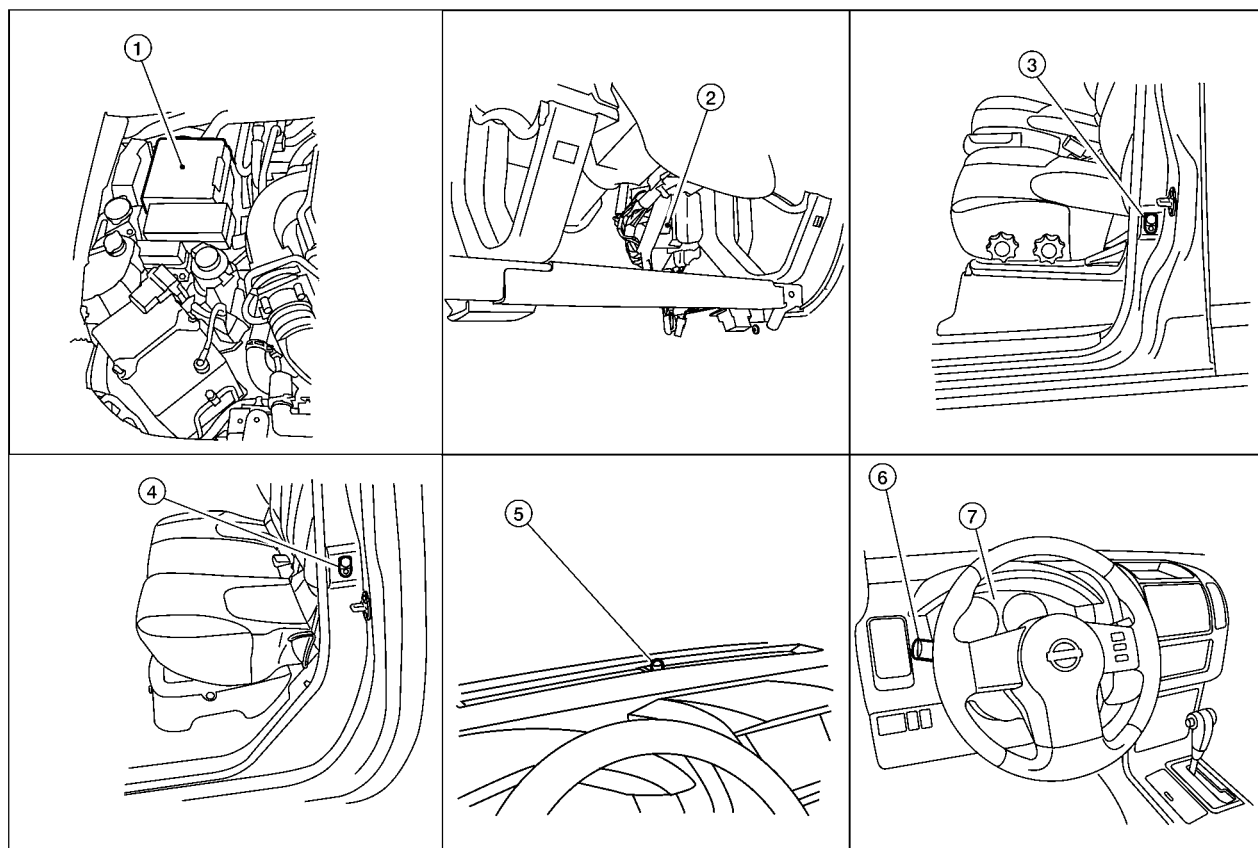

WKIA5021E

- |  |  |  |
|--|--|--|
| 1. IPDM E/R<br>E122, E123, E124          | 2. BCM<br>M18, M19, M20<br>(view with lower instrument panel LH removed) | 3. Front door switch<br>LH B8<br>RH B108       |
| 4. Rear door switch<br>LH B18<br>RH B116 | 5. Optical sensor<br>M14   | 6. Combination switch (lighting switch)<br>M28 |
| 7. Combination meter<br>M24              |  |  |

## System Description

EKS00CMD

Automatically turns on/off the parking lamps and the headlamps in accordance with ambient light. Timing for when the lamps turn on/off can be selected using four modes.

### OUTLINE

The auto light control system uses an optical sensor that detects outside brightness.

When the lighting switch is in "AUTO" position, it automatically turns on/off the parking lamps and the headlamps in accordance with the ambient light. Sensitivity can be adjusted in four steps. For the details of the setting, refer to [LT-46, "SETTING CHANGE FUNCTIONS"](#).

Optical sensor ground is supplied

- to optical sensor terminal 3
- through BCM (body control module) terminal 18.

When ignition switch is turned to "ON" position and when outside brightness is darker than prescribed level, input is supplied

- to BCM terminal 58
- through optical sensor terminal 4.

The headlamps will then illuminate. For a description of headlamp operation, refer to [LT-5, "System Description"](#).



# AUTO LIGHT SYSTEM

## COMBINATION SWITCH READING FUNCTION

Refer to [BCS-3, "COMBINATION SWITCH READING FUNCTION"](#) .

## EXTERIOR LAMP BATTERY SAVER CONTROL

When the combination switch (lighting switch) is in the AUTO position, and the ignition switch is turned from ON or ACC to OFF, and one of the front doors is opened, the battery saver control feature is activated. Under this condition, the headlamps remain illuminated for 5 minutes, then the headlamps are turned off. Exterior lamp battery saver control mode can be changed by the function setting of CONSULT-II.

## DELAY TIMER FUNCTION

When the ignition switch is ON and auto light switch is ON, the BCM turns on/off the headlamps. In delay timer function, ignition is OFF, auto light sensor power source is OFF and the headlamps are not turned on/off by the BCM. On condition that:

- when the state of ignition switch ON or ACC is ON and output judgment by auto light function is headlamp ON changes to ignition switch and ACC are OFF and any door switch is ON, output judgment by BCM should be headlamp ON for 5 minutes by timer. After time out, output judgment by BCM should be headlamp OFF.
- when the state of any door switch is turned to ON from OFF while 45 second or 5 minute timer is counting, timer stops, and restarts counting for 5 minutes, then BCM judges output as headlamp ON. After time out, BCM judges output as headlamp OFF.
- when the state of front door switch (LH), front door switch (RH), rear door switch LH or rear door switch RH is ON turns to all door switches are OFF while 45 second or 5 minute timer is counting, timer stops, and restarts counting for 45 seconds, then BCM judges output as headlamp ON. After timer out, BCM judges output as headlamp OFF.
- when the state is ignition switch ON or ACC is ON or auto light switch OFF while timer is counting, timer stops counting and BCM turns on/off lamps according to headlamp function, front fog lamp function, auto light function and headlamp battery save function.

Delay timer control mode can be changed by the function setting of CONSULT-II.

## CAN Communication System Description

EKS00BPM

Refer to [LAN-22, "CAN COMMUNICATION"](#) .

## Major Components and Functions

EKS00BPN

Components	Functions
BCM	● Turns on/off circuits of tail light and headlamp according to signals from light sensor, lighting switch (AUTO), front door switch LH, front door switch RH, rear door switches, and ignition switch (ON, OFF).
Optical sensor	● Converts ambient light (lux) to voltage, and sends it to BCM. (Detects lightness of 50 to 1,300 lux)

# AUTO LIGHT SYSTEM

## Schematic

EKS00BPO

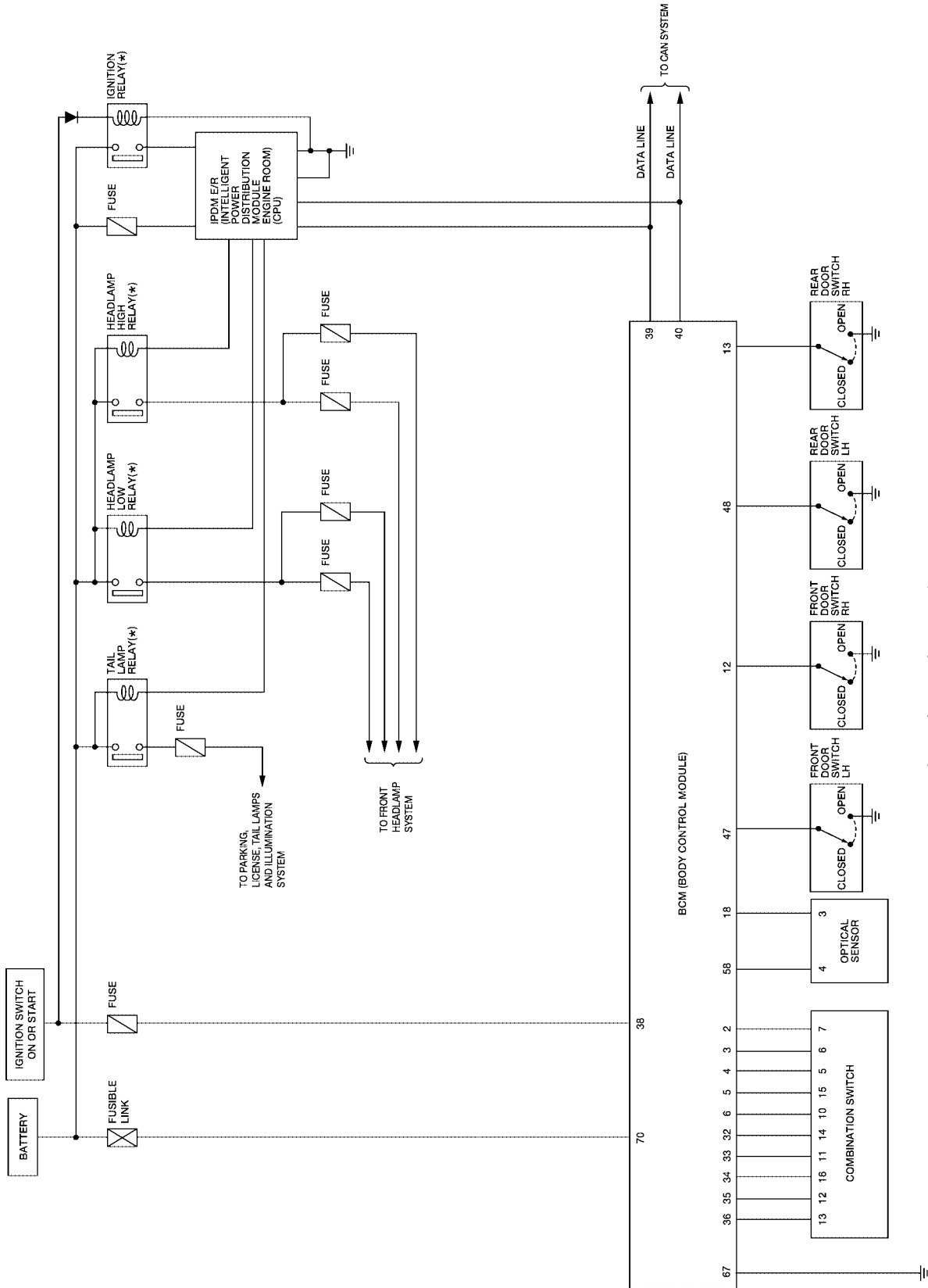

\* : THIS RELAY IS BUILT INTO THE IPDM E/R (INTELLIGENT POWER DISTRIBUTION MODULE ENGINE ROOM).

WKWA4354E

# AUTO LIGHT SYSTEM

## Wiring Diagram — AUTO/L —

EKS00BPP

### LT-AUTO/L-01

Ⓞ : CREW CAB

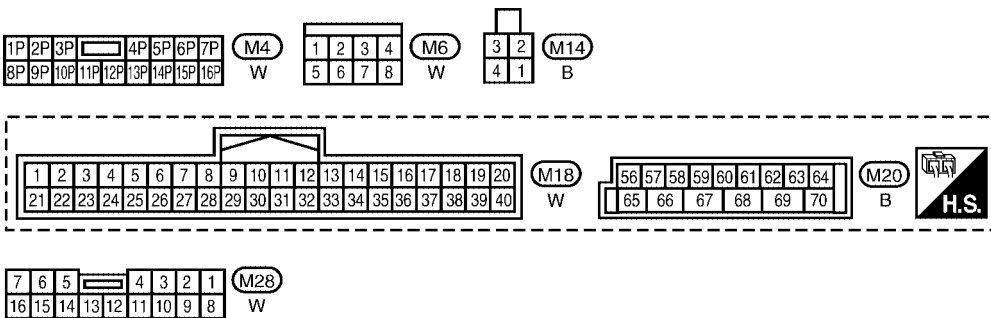
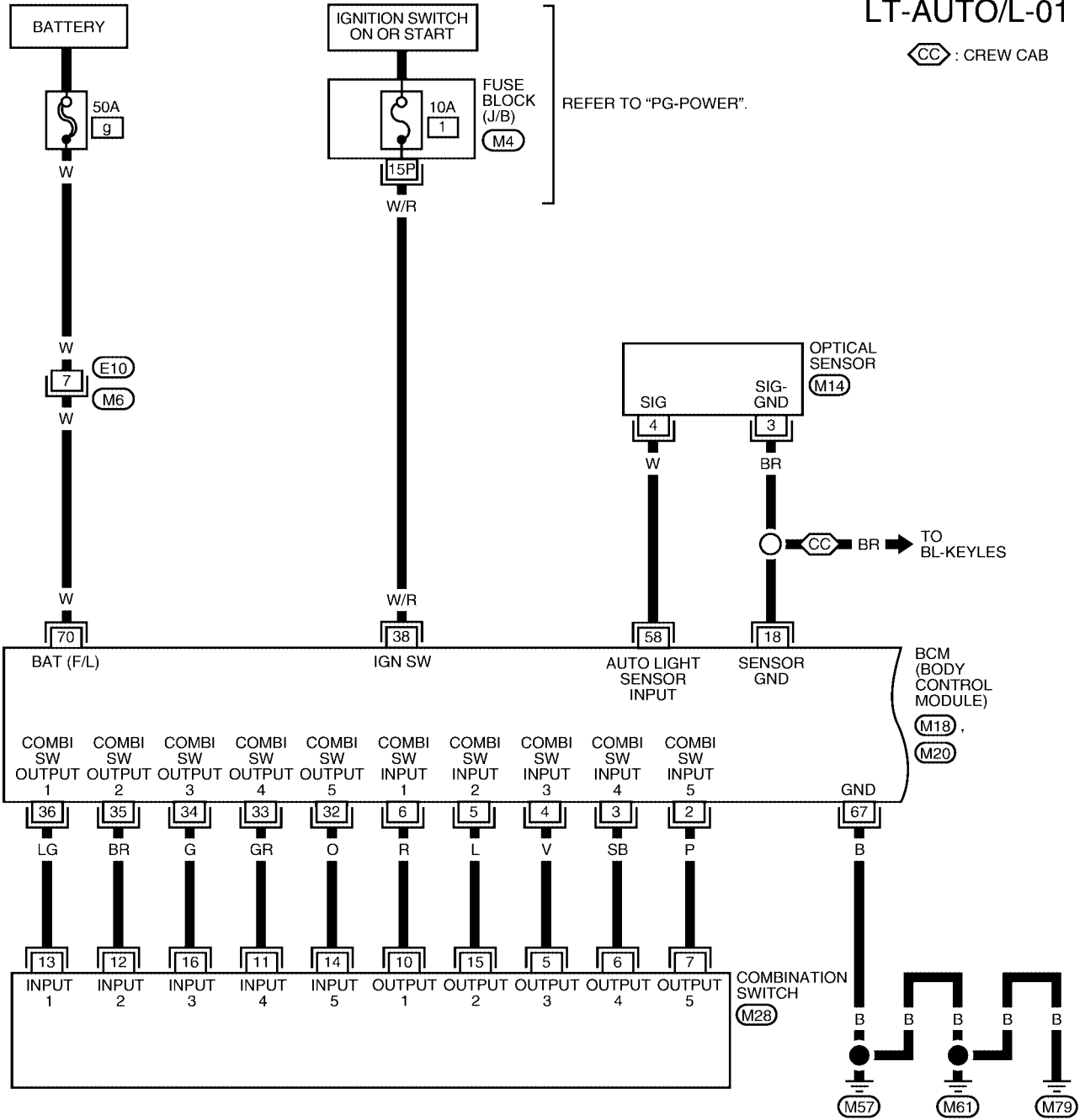

# AUTO LIGHT SYSTEM

LT-AUTO/L-02

▬ : DATA LINE

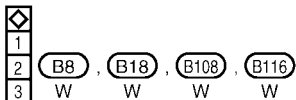
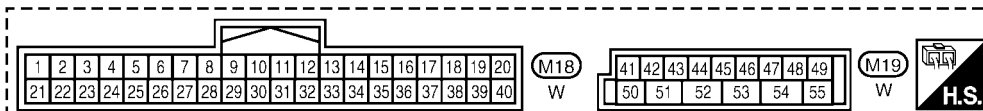
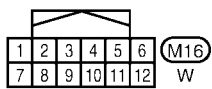
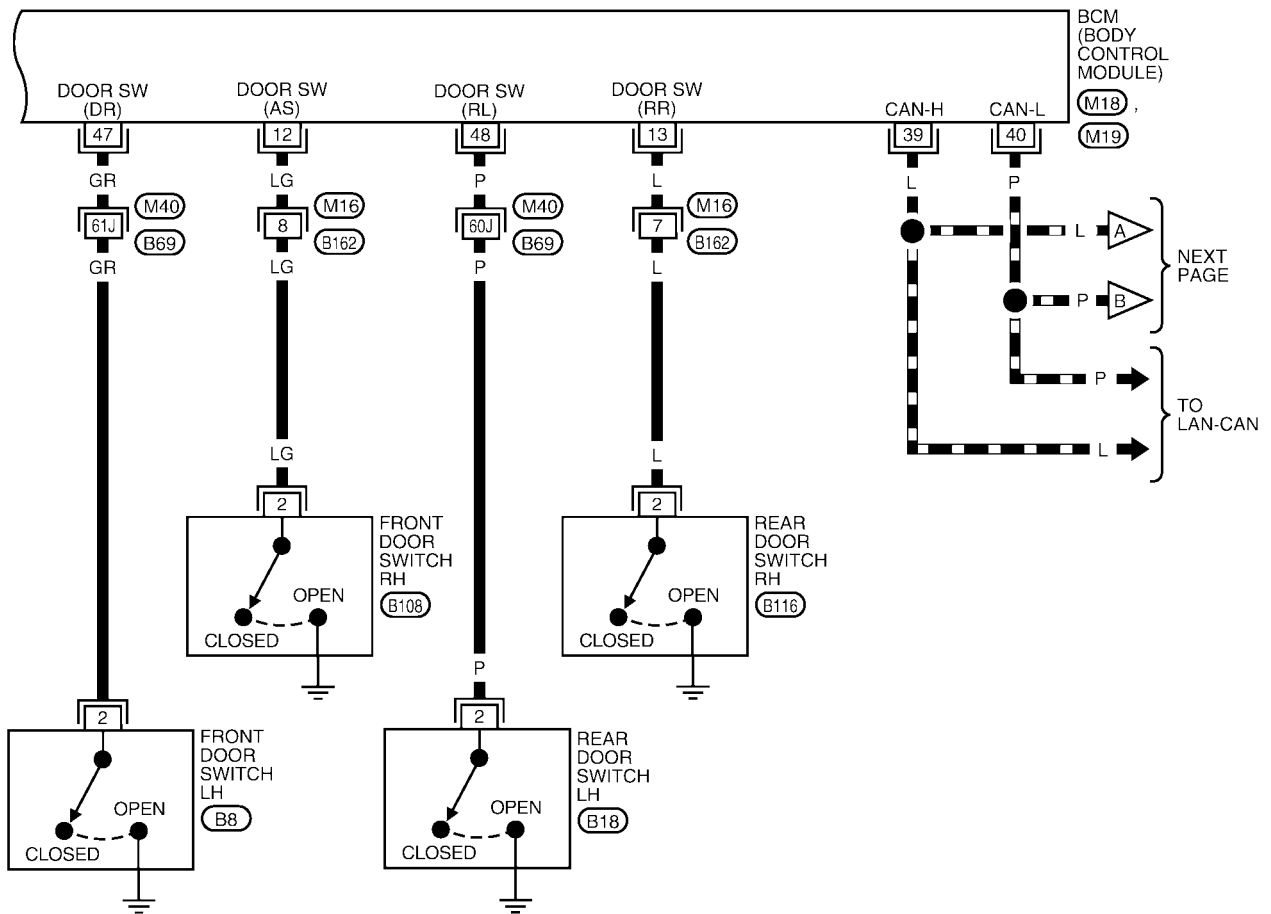

REFER TO THE FOLLOWING.  
 (M40) - SUPER  
 MULTIPLE JUNCTION (SMJ)

WKWA2202E

# AUTO LIGHT SYSTEM

LT-AUTO/L-03

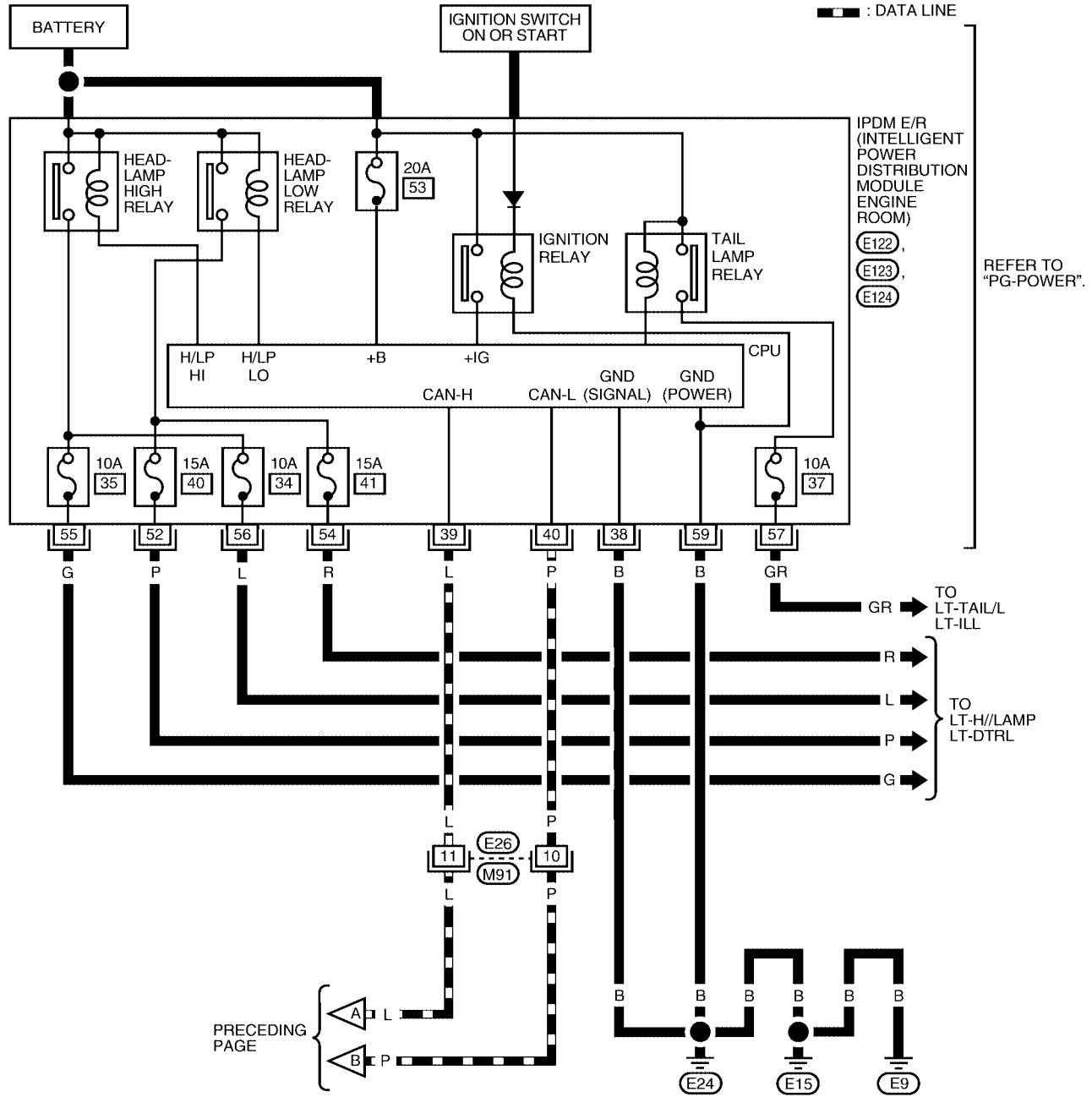

A  
B  
C  
D  
E  
F  
G  
H  
I  
J  
LT  
 L  
M

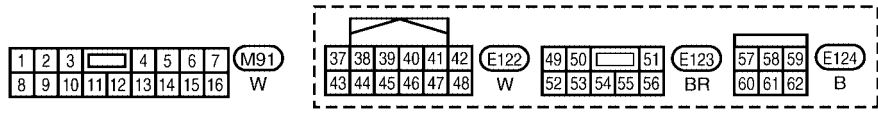

WKWA4356E

# AUTO LIGHT SYSTEM

## Terminals and Reference Values for BCM

EKS00CME

Refer to [BCS-12, "Terminals and Reference Values for BCM"](#) .

## Terminals and Reference Values for IPDM E/R

EKS00CMF

Refer to [PG-29, "Terminals and Reference Values for IPDM E/R"](#) .

## How to Proceed With Trouble Diagnosis

EKS00CMG

1. Confirm the symptom or customer complaint.
2. Understand operation description and function description. Refer to [LT-40, "System Description"](#) .
3. Carry out the Preliminary Check. Refer to [LT-46, "Preliminary Check"](#) .
4. Check symptom and repair or replace the cause of malfunction. Refer to [LT-52, "Trouble Diagnosis Chart by Symptom"](#) .
5. Does the auto light system operate normally? If YES: GO TO 6. If NO: GO TO 4.
6. Inspection End.

## Preliminary Check

EKS00CMH

### SETTING CHANGE FUNCTIONS

Sensitivity of auto light system can be adjusted using CONSULT-II. Refer to [LT-47, "WORK SUPPORT"](#) .

### CHECK BCM CONFIGURATION

#### 1. CHECK BCM CONFIGURATION

Confirm BCM configuration for "AUTO LIGHT" is set to "WITH". Refer to [BCS-20, "READ CONFIGURATION PROCEDURE"](#) .

OK or NG

- OK >> Continue preliminary check. Refer to [LT-46, "CHECK POWER SUPPLY AND GROUND CIRCUIT"](#) .
- NG >> Change BCM configuration for "AUTO LIGHT" to "WITH". Refer to [BCS-22, "WRITE CONFIGURATION PROCEDURE"](#) .

### CHECK POWER SUPPLY AND GROUND CIRCUIT

Refer to [BCS-16, "BCM Power Supply and Ground Circuit Check"](#) and [PG-31, "IPDM E/R Power/Ground Circuit Inspection"](#) .

## CONSULT-II Function (BCM)

EKS00CMI

CONSULT-II can display each diagnostic item using the diagnostic test modes shown following.

BCM diagnostic test item	Diagnostic mode	Description
Inspection by part	WORK SUPPORT	Supports inspections and adjustments. Commands are transmitted to the BCM for setting the status suitable for required operation, input/output signals are received from the BCM and received data is displayed.
	DATA MONITOR	Displays BCM input/output data in real time.
	ACTIVE TEST	Operation of electrical loads can be checked by sending drive signal to them.
	SELF-DIAG RESULTS	Displays BCM self-diagnosis results.
	CAN DIAG SUPPORT MNTR	The result of transmit/receive diagnosis of CAN communication can be read.
	ECU PART NUMBER	BCM part number can be read.
CONFIGURATION	Performs BCM configuration read/write functions.	

## CONSULT-II OPERATION

### CAUTION:

If CONSULT-II is used with no connection of CONSULT-II CONVERTER, malfunctions might be detected in self-diagnosis depending on control unit which carries out CAN communication.

# AUTO LIGHT SYSTEM

1. With the ignition switch OFF, connect CONSULT-II and CONSULT-II CONVERTER to the data link connector, then turn ignition switch ON.

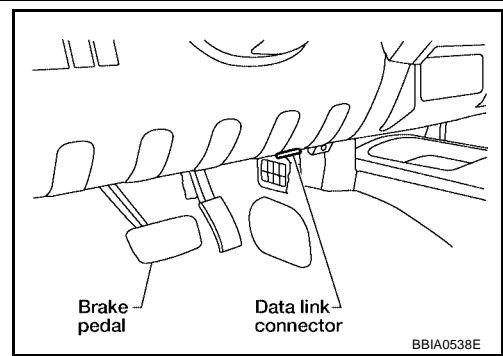

2. Touch "START (NISSAN BASED VHCL)".

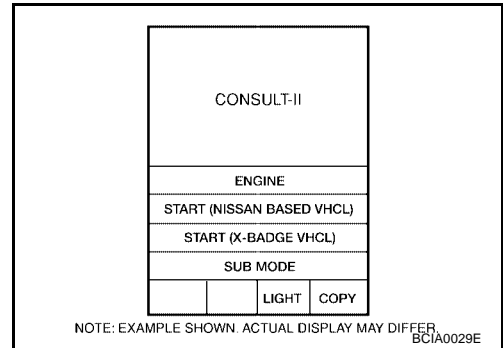

3. Touch "BCM" on "SELECT SYSTEM" screen. If "BCM" is not indicated, go to [GI-41, "CONSULT-II Data Link Connector \(DLC\) Circuit"](#).

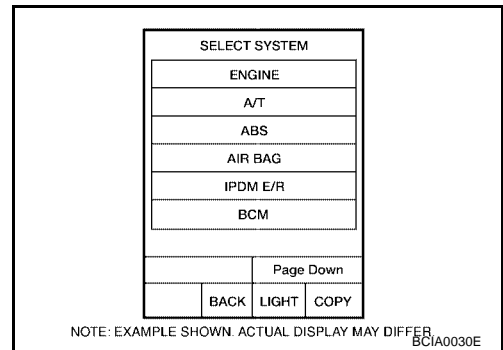

4. Touch "HEAD LAMP" on "SELECT TEST ITEM" screen.

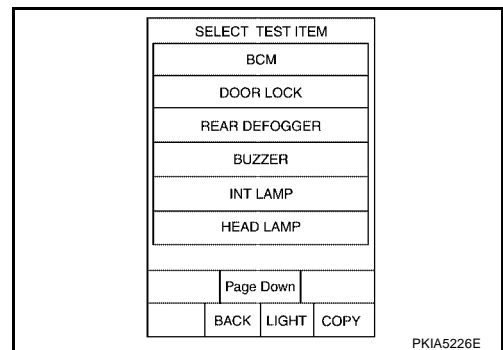

## WORK SUPPORT

### Operation Procedure

1. Touch "HEAD LAMP" on "SELECT TEST ITEM" screen.
2. Touch "WORK SUPPORT" on "SELECT DIAG MODE" screen.
3. Touch "CUSTOM A/LIGHT SETTING" or "ILL DELAY SET" on "SELECT WORK ITEM" screen.
4. Touch "START".
5. Touch "MODE 1-4" of setting to be changed (CUSTOM A/LIGHT SETTING). Touch "MODE1-8" of setting to be changed (ILL DELAY SET).
6. Touch "CHANGE SETT".

A  
B  
C  
D  
E  
F  
G  
H  
I  
J  
LT  
L  
M

# AUTO LIGHT SYSTEM

7. The setting will be changed and "CUSTOMIZING COMPLETED" will be displayed.

8. Touch "END".

## Work Support Setting Item

Sensitivity of auto light can be selected and set from four modes.

Work item	Description
CUSTOM A/LIGHT SETTING	Auto light sensitivity can be changed in this mode. Sensitivity can be adjusted in four modes. <ul style="list-style-type: none"> <li>● MODE 1 (Normal-default)/ MODE 2 (Desensitized)/MODE 3 (Sensitive)/MODE4 (Insensitive)</li> </ul>
ILL DELAY SET	Auto light delay off timer period can be changed in this mode. Selects auto light delay off timer period among eight modes. <ul style="list-style-type: none"> <li>● MODE 1 (45 sec.)/MODE 2 (OFF)/MODE 3 (30 sec.)/MODE 4 (60 sec.)/MODE 5 (90 sec.)/MODE 6 (120 sec.)/MODE 7 (150 sec.)/MODE 8 (180 sec.)</li> </ul>

## DATA MONITOR

### Operation Procedure

1. Touch "HEAD LAMP" on "SELECT TEST ITEM" screen.
2. Touch "DATA MONITOR" on "SELECT DIAG MODE" screen.
3. Touch either "ALL SIGNALS" or "SELECTION FROM MENU" on the "SELECT MONITOR ITEM" screen.

ALL SIGNALS	Monitors all the signals.
SELECTION FROM MENU	Selects and monitors individual signal.

4. Touch "START".
5. When "SELECTION FROM MENU" is selected, touch individual items to be monitored. When "ALL SIGNALS" is selected, all the items will be monitored.
6. Touch "RECORD" while monitoring, then the status of the monitored item can be recorded. To stop recording, touch "STOP".

### Display Item List

Monitor item	Contents
IGN ON SW                    "ON/OFF"	Displays "IGN position (ON)/OFF, ACC position (OFF)" judged from the ignition switch signal.
ACC ON SW                    "ON/OFF"	Displays "ACC (ON)/OFF, Ignition OFF (OFF)" status judged from ignition switch signal.
HI BEAM SW                    "ON/OFF"	Displays status (high beam switch: ON/Others: OFF) of high beam switch judged from lighting switch signal.
HEAD LAMP SW 1              "ON/OFF"	Displays status (headlamp switch 1: ON/Others: OFF) of headlamp switch 2 judged from lighting switch signal.
HEAD LAMP SW 2              "ON/OFF"	Displays status (headlamp switch 2: ON/Others: OFF) of headlamp switch 2 judged from lighting switch signal.
LIGHT SW 1ST                "ON/OFF"	Displays status (lighting switch 1st position: ON/Others: OFF) of lighting switch judged from lighting switch signal.
AUTO LIGHT SW                "ON/OFF"	Displays status of the lighting switch as judged from the lighting switch signal. (AUTO position: ON/Other than AUTO position: OFF)
PASSING SW                    "ON/OFF"	Displays status (flash-to-pass switch: ON/Others: OFF) of flash-to-pass switch judged from lighting switch signal.
FR FOG SW                    "ON/OFF"	Displays status (front fog lamp switch: ON/Others: OFF) of front fog lamp switch judged from lighting switch signal.
DOOR SW-DR                  "ON/OFF"	Displays status of the driver door as judged from the driver door switch signal. (Door is open: ON/Door is closed: OFF)
DOOR SW-AS                  "ON/OFF"	Displays status of the passenger door as judged from the passenger door switch signal. (Door is open: ON/Door is closed: OFF)
DOOR SW-RR                  "ON/OFF"	Displays status of the rear door as judged from the rear door switch (RH) signal. (Door is open: ON/Door is closed: OFF)
DOOR SW-RL                  "ON/OFF"	Displays status of the rear door as judged from the rear door switch (LH) signal. (Door is open: ON/Door is closed: OFF)



# AUTO LIGHT SYSTEM

Monitor item		Contents
BACK DOOR SW	"ON/OFF"	Not used.
TURN SIGNAL R	"ON/OFF"	Displays status (Turn right: ON/Others: OFF) as judged from lighting switch signal.
TURN SIGNAL L	"ON/OFF"	Displays status (Turn left: ON/Others: OFF) as judged from lighting switch signal.
CARGO LAMP SW	"ON/OFF"	Displays status of cargo lamp.
OPTICAL SENSOR	[0 - 5V]	Displays "ambient light (close to 5V when dark/close to 0V when light)" judged from optical sensor signal.

## ACTIVE TEST

### Operation Procedure

1. Touch "HEAD LAMP" on "SELECT TEST ITEM" screen.
2. Touch "ACTIVE TEST" on "SELECT DIAG MODE" screen.
3. Touch item to be tested and check operation of the selected item.
4. During the operation check, touching "BACK" deactivates the operation.

### Display Item List

Test item	Description
TAIL LAMP	Allows tail lamp relay to operate by switching ON-OFF.
HEAD LAMP	Allows headlamp relay (HI, LO) to operate by switching ON-OFF.
FR FOG LAMP	Allows fog lamp relay to operate by switching ON-OFF.
CARGO LAMP	Allows cargo lamp to operate by switching ON-OFF.

A  
B  
C  
D  
E  
F  
G  
H  
I  
J  
L  
M

LT

# AUTO LIGHT SYSTEM

## CONSULT-II Function (IPDM E/R)

EKS00CMJ

CONSULT-II can display each diagnostic item using the diagnostic test modes shown following.

IPDM E/R diagnostic mode	Description
SELF-DIAG RESULTS	Displays IPDM E/R self-diagnosis results.
DATA MONITOR	Displays IPDM E/R input/output data in real time.
CAN DIAG SUPPORT MNTR	The result of transmit/receive diagnosis of CAN communication can be read.
ACTIVE TEST	Operation of electrical loads can be checked by sending drive signal to them.

## CONSULT-II OPERATION

### CAUTION:

If CONSULT-II is used with no connection of CONSULT-II CONVERTER, malfunctions might be detected in self-diagnosis depending on control unit which carries out CAN communication.

1. With the ignition switch OFF, connect CONSULT-II and CONSULT-II CONVERTER to the data link connector, then turn the ignition switch ON.

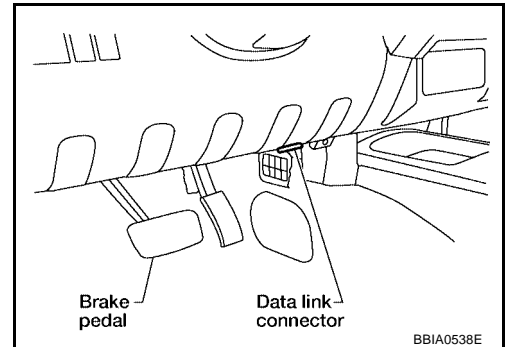

2. Touch "START (NISSAN BASED VHCL)".

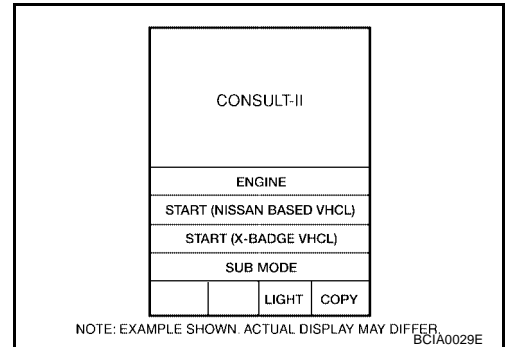

3. Touch "IPDM E/R" on "SELECT SYSTEM" screen. If "IPDM E/R" is not displayed, go to [GI-41, "CONSULT-II Data Link Connector \(DLC\) Circuit"](#).

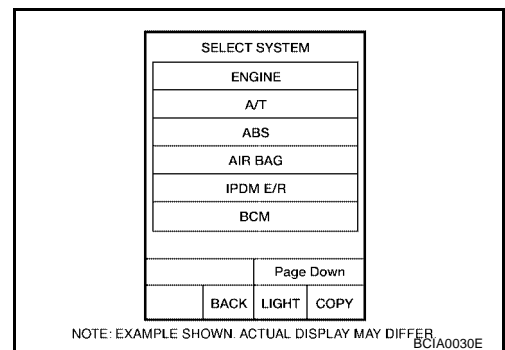

# AUTO LIGHT SYSTEM

4. Select the desired part to be diagnosed on the "SELECT DIAG MODE" screen.

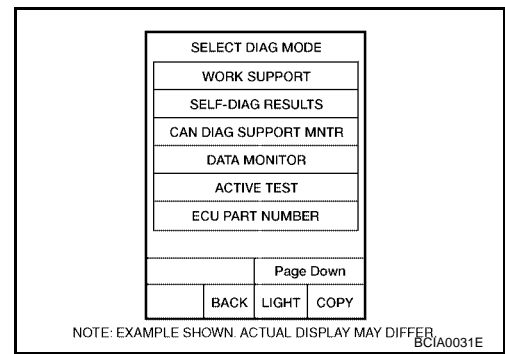

## DATA MONITOR

### Operation Procedure

1. Touch "DATA MONITOR" on "SELECT DIAG MODE" screen.
2. Touch "ALL SIGNALS", "MAIN SIGNALS" or "SELECTION FROM MENU" on the "SELECT MONITOR ITEM" screen.

ALL SIGNALS	All items will be monitored.
MAIN SIGNALS	Monitor the predetermined item.
SELECTION FROM MENU	Select any item for monitoring.

3. Touch "START".
4. Touch the required monitoring item on "SELECTION FROM MENU". In "ALL SIGNALS", all items are monitored. In "MAIN SIGNALS", predetermined items are monitored.
5. Touch "RECORD" while monitoring to record the status of the item being monitored. To stop recording, touch "STOP".

### All Signals, Main Signals, Selection From Menu

Item name	CONSULT-II screen display	Display or unit	Monitor item selection			Description
			ALL SIGNALS	MAIN SIGNALS	SELECTION FROM MENU	
Parking, license plate and tail lamps request	TAIL&CLR REQ	ON/OFF	×	×	×	Signal status input from BCM
Headlamp low beam request	HL LO REQ	ON/OFF	×	×	×	Signal status input from BCM
Headlamp high beam request	HL HI REQ	ON/OFF	×	×	×	Signal status input from BCM
Front fog lamps request	FR FOG REQ	ON/OFF	×	×	×	Signal status input from BCM

#### NOTE:

Perform monitoring of IPDM E/R data with the ignition switch ON. When the ignition switch is at ACC, the display may not be correct.

## ACTIVE TEST

### Operation Procedure

1. Touch "ACTIVE TEST" on "SELECT DIAG MODE" screen.
2. Touch item to be tested, and check operation.
3. Touch "START".
4. Touch "STOP" while testing to stop the operation.

# AUTO LIGHT SYSTEM

Test item	CONSULT-II screen display	Description
Tail lamp relay output	TAIL LAMP	Allows tail lamp relay to operate by switching operation ON-OFF at your option.
Headlamp relay (HI, LO) output	LAMPS	Allows headlamp relay (HI, LO) to operate by switching operation (OFF, HI, LO) at your option (Headlamp high beam repeats ON-OFF every 1 second).
Front fog lamp relay output		Allows fog lamp relay to operate by switching operation ON-OFF at your option.

## Trouble Diagnosis Chart by Symptom

EKS00CMK

Trouble phenomenon	Malfunction system and reference
<ul style="list-style-type: none"> <li>● Parking lamps and headlamps will not illuminate when outside of the vehicle becomes dark. (Lighting switch 1st position and 2nd position operate normally.)</li> <li>● Parking lamps and headlamp will not go out when outside of the vehicle becomes light. (Lighting switch 1st position and 2nd position operate normally.)</li> <li>● Headlamps go out when outside of the vehicle becomes light, but parking lamps stay on.</li> </ul>	<ul style="list-style-type: none"> <li>● Refer to <a href="#">LT-47. "WORK SUPPORT"</a> .</li> <li>● Refer to <a href="#">LT-52. "Lighting Switch Inspection"</a> .</li> <li>● Refer to <a href="#">LT-53. "Optical Sensor System Inspection"</a> .</li> </ul> <p>If above systems are normal, replace BCM. Refer to <a href="#">BCS-26. "Removal and Installation"</a> .</p>
Parking lamps illuminate when outside of the vehicle becomes dark, but headlamps stay off. (Lighting switch 1st position and 2nd position operate normally.)	<ul style="list-style-type: none"> <li>● Refer to <a href="#">LT-47. "WORK SUPPORT"</a> .</li> <li>● Refer to <a href="#">LT-53. "Optical Sensor System Inspection"</a> .</li> </ul> <p>If above systems are normal, replace BCM. Refer to <a href="#">BCS-26. "Removal and Installation"</a> .</p>
Auto light adjustment system will not operate. (Lighting switch AUTO, 1st position and 2nd position operate normally.)	<ul style="list-style-type: none"> <li>● Refer to <a href="#">LT-53. "Optical Sensor System Inspection"</a> .</li> </ul> <p>If above system is normal, replace BCM. Refer to <a href="#">BCS-26. "Removal and Installation"</a> .</p>
Auto light adjustment system will not operate.	<ul style="list-style-type: none"> <li>● CAN communication line to BCM inspection. Refer to <a href="#">BCS-19. "CAN Communication Inspection Using CONSULT-II (Self-Diagnosis)"</a> .</li> </ul>
Shut off delay feature will not operate.	<ul style="list-style-type: none"> <li>● CAN communication line inspection between BCM and combination meter. Refer to <a href="#">BCS-19. "CAN Communication Inspection Using CONSULT-II (Self-Diagnosis)"</a> .</li> <li>● Refer to <a href="#">BL-68. "Door Switch Check (King Cab)"</a> or <a href="#">BL-70. "Door Switch Check (Crew Cab)"</a> .</li> </ul> <p>If above system is normal, replace BCM. Refer to <a href="#">BCS-26. "Removal and Installation"</a> .</p>

## Lighting Switch Inspection

EKS00CML

### 1. CHECK LIGHTING SWITCH INPUT SIGNAL

Ⓟ With CONSULT-II

Select "BCM" on CONSULT-II. With "HEAD LAMP" data monitor, make sure "AUTO LIGHT SW" turns ON-OFF linked with operation of lighting switch.

**When lighting switch is in AUTO position : AUTO LIGHT SW ON**

ⓧ Without CONSULT-II

Refer to [LT-81. "Combination Switch Inspection"](#) .

OK or NG

OK >> Inspection End.

NG >> Check lighting switch. Refer to [LT-81. "Combination Switch Inspection"](#) .

DATA MONITOR	
MONITOR	
AUTO LIGHT SW	ON

SKIA4196E

# AUTO LIGHT SYSTEM

EKS00CMM

## Optical Sensor System Inspection

### 1. CHECK OPTICAL SENSOR INPUT SIGNAL

④ With CONSULT-II

Select "BCM" on CONSULT-II. With "OPTICAL SENSOR" data monitor, check difference in the voltage when the optical sensor is illuminated and not illuminated.

**Illuminated**

**OPTICAL SENSOR : 3.1V or more**

**Not illuminated**

**OPTICAL SENSOR : 0.6V or less**

#### NOTE:

Optical sensor must be completely subjected to work lamp light. If the optical sensor is insufficiently illuminated, the measured value may not satisfy the standard.

⊗ Without CONSULT-II

GO TO 2.

OK or NG

OK >> Inspection End.

NG >> GO TO 2.

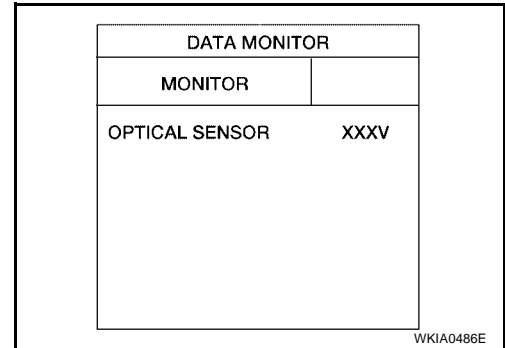

### 2. CHECK OPTICAL SENSOR SIGNAL GROUND CIRCUIT

1. Turn ignition switch OFF.
2. Disconnect BCM connector and optical sensor connector.
3. Check continuity (open circuit) between BCM harness connector M18 terminal 18 and optical sensor harness connector M14 terminal 3.

**18 - 3 : Continuity should exist.**

4. Check continuity (short circuit) between BCM harness connector M18 terminal 18 and ground.

**18 - Ground : Continuity should not exist.**

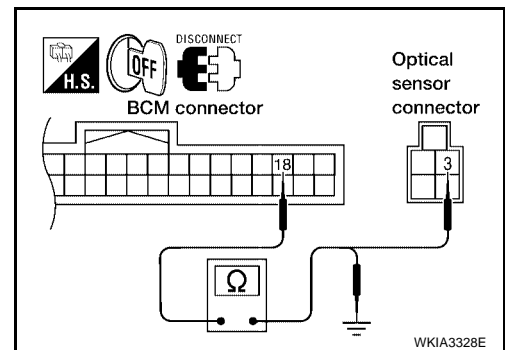

OK or NG

OK >> GO TO 3.

NG >> Repair harness or connector.

### 3. CHECK OPTICAL SENSOR SIGNAL CIRCUIT

1. Check continuity (open circuit) between BCM harness connector M20 terminal 58 and optical sensor harness connector M14 terminal 4.

**58 - 4 : Continuity should exist.**

2. Check continuity (short circuit) between BCM harness connector M20 terminal 58 and ground.

**58 - Ground : Continuity should not exist.**

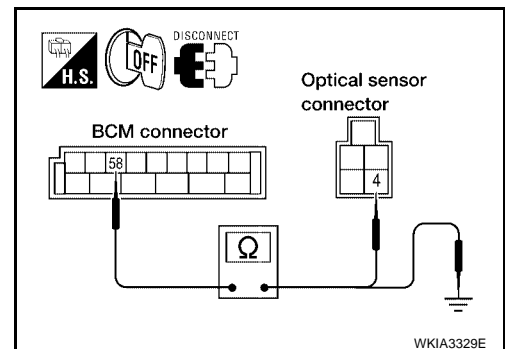

OK or NG

OK >> Replace optical sensor. Refer to [LT-54, "Removal and Installation of Optical Sensor"](#). Recheck sensor output with CONSULT-II. If NG, replace BCM. Refer to [BCS-26, "Removal and Installation"](#).

NG >> Repair harness or connector.

# AUTO LIGHT SYSTEM

## Removal and Installation of Optical Sensor

EKS00BPZ

### REMOVAL

1. Using a thin blade screwdriver, gently pry upward to release optical sensor from defrost grille.
2. Disconnect the optical sensor connector.

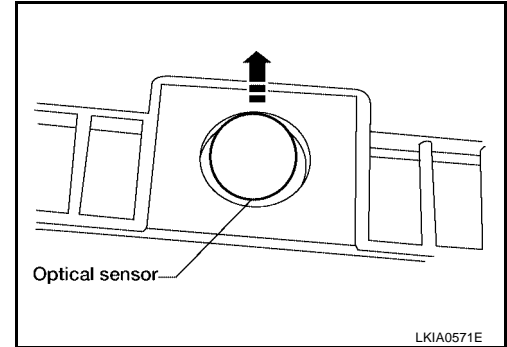

### Installation

Installation is in the reverse order of removal.

# FRONT FOG LAMP

PFP:26150

## FRONT FOG LAMP

### Component Parts and Harness Connector Location

EKS00BQ0

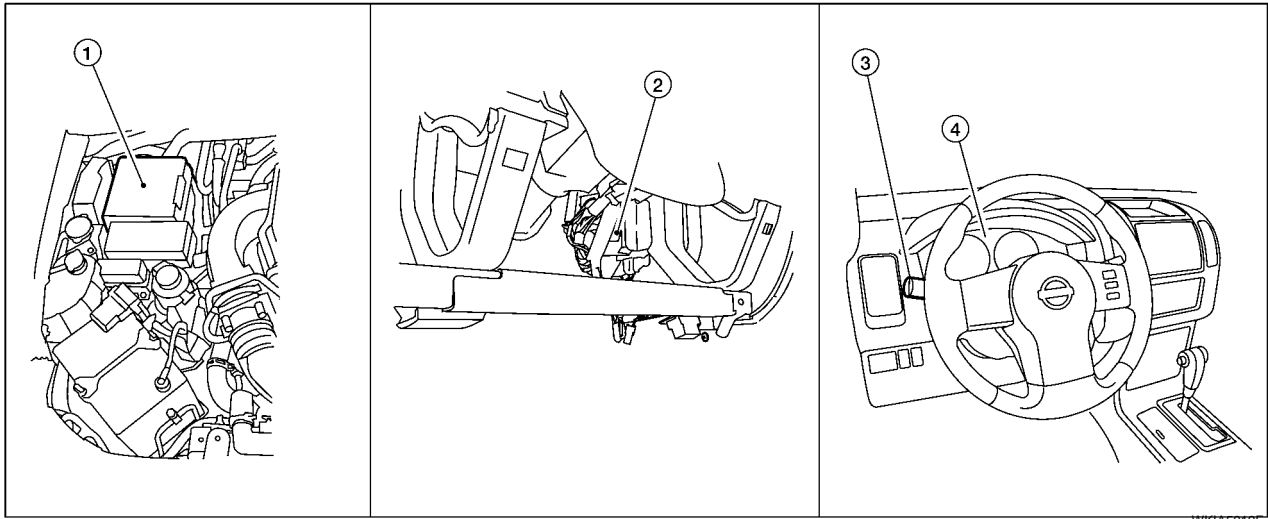

1. IPDM E/R  
E122, E123, E124

2. BCM  
M18, M20  
(view with lower instrument panel LH removed)

3. Combination switch (lighting switch)  
M28

## System Description

EKS00CMN

Control of the fog lamps is dependent upon the position of the combination switch (lighting switch). The lighting switch must be in the 2ND position or AUTO position (LOW beam is ON) for front fog lamp operation. When the lighting switch is placed in the fog lamp position, the BCM (body control module) receives input signal requesting the fog lamps to illuminate. When the headlamps are illuminated, this input signal is communicated to the IPDM E/R (intelligent power distribution module engine room) across the CAN communication lines. The CPU (central processing unit) of the IPDM E/R controls the front fog lamp relay coil. When activated, this relay directs power to the front fog lamps.

## OUTLINE

Power is supplied at all times

- to front fog lamp relay, located in the IPDM E/R, and
- to ignition relay, located in the IPDM E/R, and
- through 20A fuse (No. 53, located in the IPDM E/R)
- to CPU of the IPDM E/R, and
- through 50A fusible link (letter **g**, located in the fuse and fusible link box)
- to BCM terminal 70.

When the ignition switch is in ON or START position, power is supplied

- to ignition relay, located in the IPDM E/R, and
- through 10A fuse [No. 1, located in the fuse block (J/B)]
- to BCM terminal 38.

Ground is supplied

- to BCM terminal 67
- through grounds M57, M61 and M79, and
- to IPDM E/R terminals 38 and 59
- through grounds E9, E15 and E24.

## FOG LAMP OPERATION

The fog lamp switch is built into the combination switch. The lighting switch must be in the 2ND position or AUTO position (LOW beam is ON) and the fog lamp switch must be ON for fog lamp operation. With the fog lamp switch in the ON position, the CPU of the IPDM E/R grounds the coil side of the fog lamp relay. The fog lamp relay then directs power

A  
B  
C  
D  
E  
F

G

H

I

J

LT

L

M

## FRONT FOG LAMP

---

- through 20A fuse (No. 56, located in the IPDM E/R)
- through IPDM E/R terminal 50
- to front fog lamp LH terminal 1, and
- through IPDM E/R terminal 51
- to front fog lamp RH terminal 1.

Ground is supplied

- to front fog lamp LH and RH terminal 2
- through grounds E9, E15 and E24.

With power and ground supplied, the front fog lamps illuminate.

### COMBINATION SWITCH READING FUNCTION

Refer to [BCS-3, "COMBINATION SWITCH READING FUNCTION"](#) .

### EXTERIOR LAMP BATTERY SAVER CONTROL

When the combination switch (lighting switch) is in the 2ND position (ON), the fog lamp switch is ON, and the ignition switch is turned from ON or ACC to OFF, the battery saver control feature is activated.

Under this condition, the fog lamps (and headlamps) remain illuminated for 5 minutes, then the fog lamps (and headlamps) are turned off.

Exterior lamp battery saver control mode can be changed by the function setting of CONSULT-II.

### CAN Communication System Description

EKS00BQ2

Refer to [LAN-22, "CAN COMMUNICATION"](#) .



# FRONT FOG LAMP

## Wiring Diagram — F/FOG —

EKS00BQ3

LT-F/FOG-01

— : DATA LINE

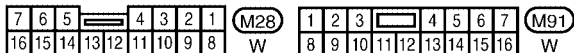
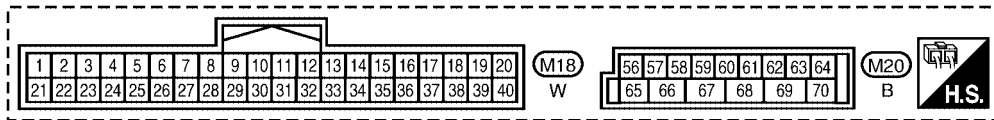
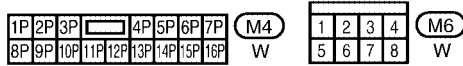
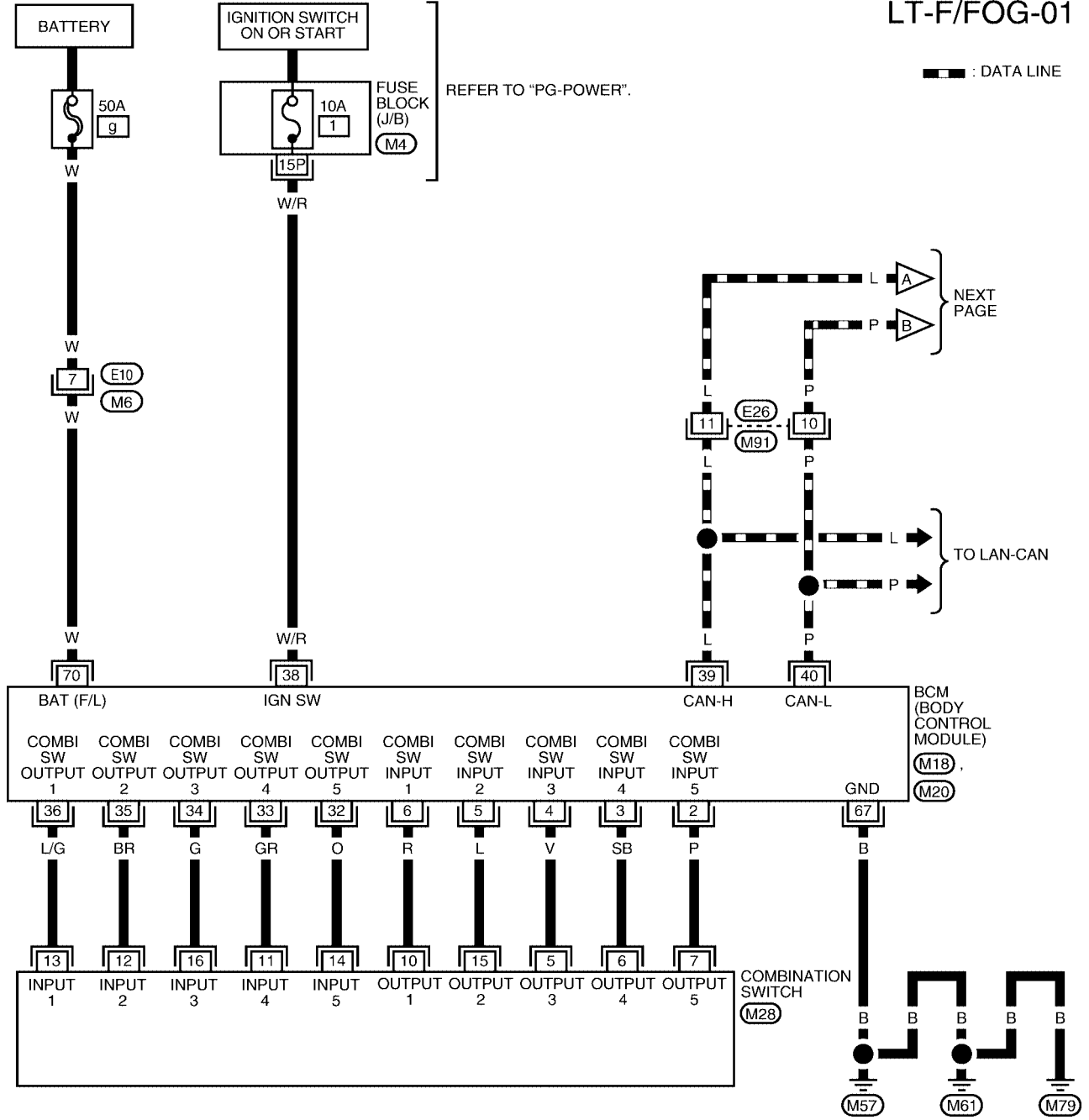

WKWA4357E

# FRONT FOG LAMP

LT-F/FOG-02

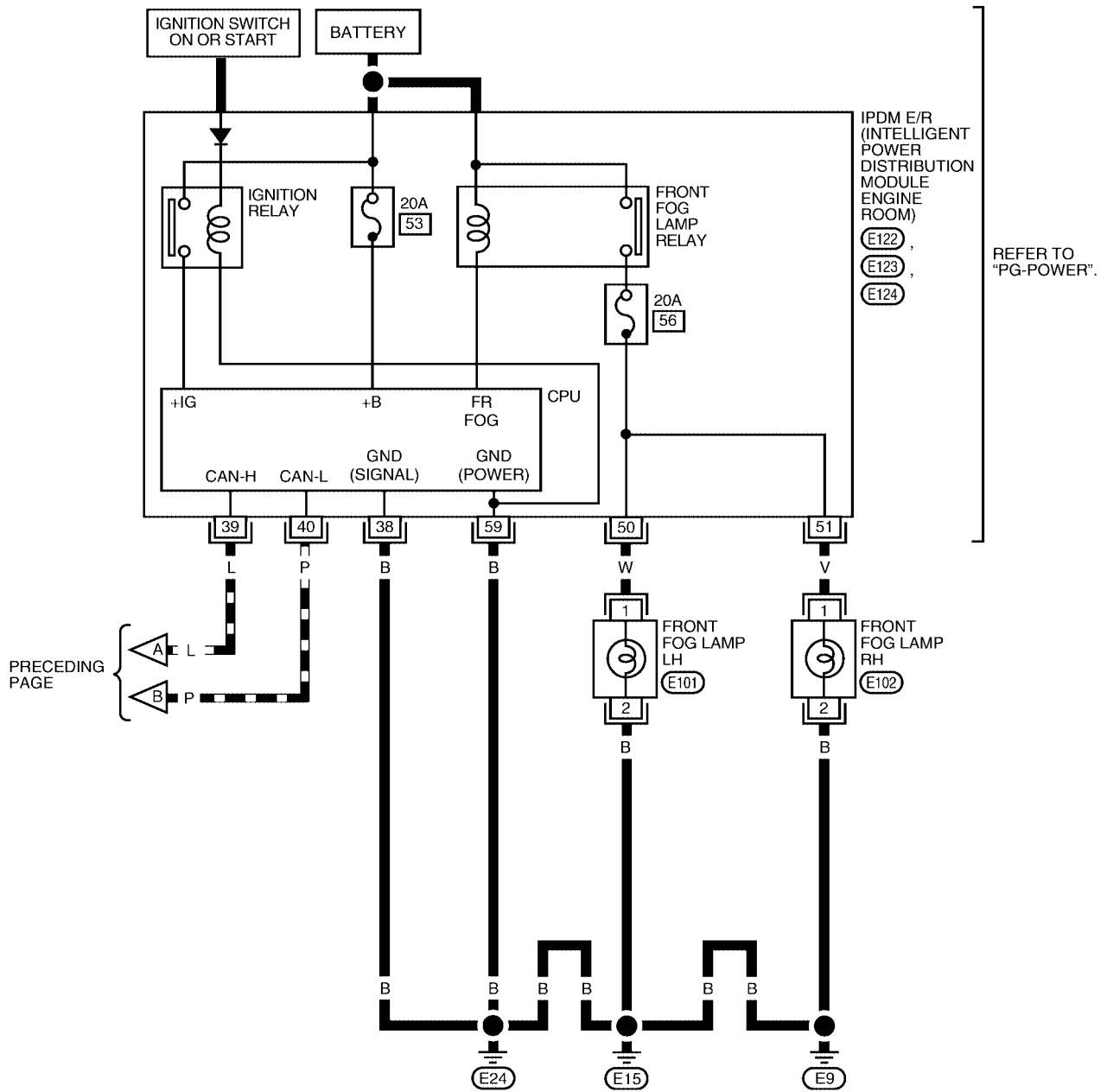

PRECEDING PAGE

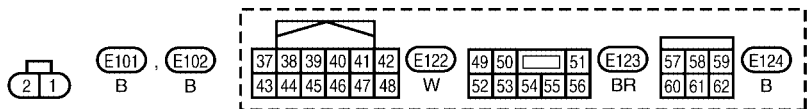

WKWA2846E

# FRONT FOG LAMP

## Terminals and Reference Values for BCM

EKS00CMO

Refer to [BCS-12, "Terminals and Reference Values for BCM"](#) .

## Terminals and Reference Values for IPDM E/R

EKS00CMP

Refer to [PG-29, "Terminals and Reference Values for IPDM E/R"](#) .

## How to Proceed With Trouble Diagnosis

EKS00CMQ

1. Confirm the symptom or customer complaint.
2. Understand operation description and function description. Refer to [LT-55, "System Description"](#) .
3. Perform the Preliminary Check. Refer to [LT-59, "Preliminary Check"](#) .
4. Check symptom and repair or replace the cause of malfunction.
5. Does the front fog lamp operate normally? If YES: GO TO 6. If NO: GO TO 4.
6. Inspection End.

## Preliminary Check

EKS00CMR

### CHECK POWER SUPPLY AND GROUND CIRCUIT

Refer to [BCS-16, "BCM Power Supply and Ground Circuit Check"](#) and [PG-31, "IPDM E/R Power/Ground Circuit Inspection"](#) .

## CONSULT-II Functions

EKS00CMS

Refer to [LT-12, "CONSULT-II Function \(BCM\)"](#) .  
Refer to [LT-15, "CONSULT-II Function \(IPDM E/R\)"](#) .

## Front Fog Lamps Do Not Illuminate (Both Sides)

EKS00CMT

### 1. CHECK COMBINATION SWITCH INPUT SIGNAL

Select "BCM" on CONSULT-II. With "HEAD LAMP" data monitor, make sure "FR FOG SW" turns ON-OFF linked with operation of lighting switch.

**When lighting switch is in FOG position : FR FOG SW ON**

OK or NG

- OK >> GO TO 2.
- NG >> Check lighting switch. Refer to [LT-81, "Combination Switch Inspection"](#) .

DATA MONITOR	
MONITOR	
FR FOG SW	ON

SKIA5897E

### 2. FOG LAMP ACTIVE TEST

1. Select "IPDM E/R" on CONSULT-II, and select "ACTIVE TEST" on "SELECT DIAG MODE" screen.
2. Select "EXTERNAL LAMPS" on "SELECT TEST ITEM" screen.
3. Touch "FOG" on "ACTIVE TEST" screen.
4. Make sure fog lamps operate.

**Fog lamps should operate.**

OK or NG

- OK >> GO TO 3.
- NG >> GO TO 4.

ACTIVE TEST			
EXTERNAL LAMPS		OFF	
		TAIL	
LO		HI	
FOG			
MODE	BACK	LIGHT	COPY

WKIA1438E

# FRONT FOG LAMP

## 3. CHECK IPDM E/R

1. Select "IPDM E/R" on CONSULT-II, and select "DATA MONITOR" on "SELECT DIAG MODE" screen.
2. Make sure "FR FOG REQ" turns ON when lighting switch is in FOG position.

**When lighting switch is in FOG position : FR FOG REQ ON**

OK or NG

- OK >> Replace IPDM E/R. Refer to [PG-33, "Removal and Installation of IPDM E/R"](#) .
- NG >> Replace BCM. Refer to [BCS-26, "Removal and Installation"](#) .

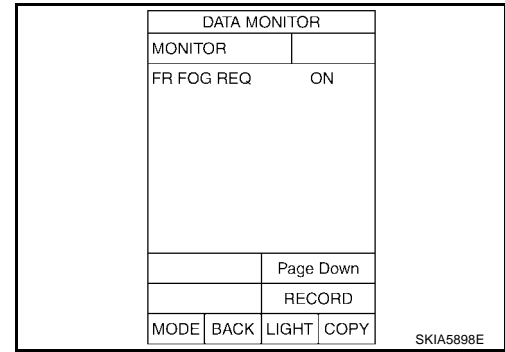

## 4. IPDM E/R INSPECTION

Start auto active test. Refer to [PG-24, "Auto Active Test"](#) . When front fog lamp relay is operating, check voltage between left/right front fog lamp connector terminals and ground.

Front fog lamp (+)		Terminal	(-)	Voltage (Approx.)
Connector				
LH	E101	1	Ground	Battery voltage
RH	E102			

OK or NG

- OK >> Check front fog lamp bulbs and replace as necessary. Refer to [LT-62, "Bulb Replacement"](#) .
- NG >> Replace IPDM E/R. Refer to [PG-33, "Removal and Installation of IPDM E/R"](#) .

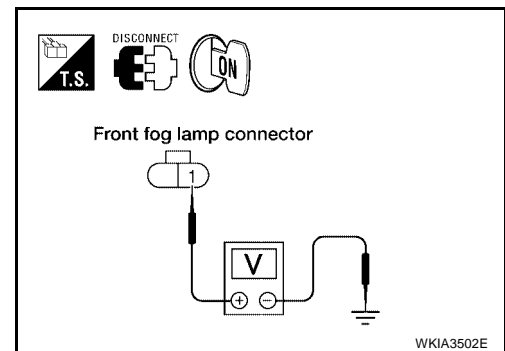

## Front Fog Lamp Does Not Illuminate (One Side)

EKS00CMU

### 1. BULB INSPECTION

Inspect bulb of lamp which does not illuminate.

OK or NG

- OK >> GO TO 2.
- NG >> Replace lamp bulb. Refer to [LT-62, "Bulb Replacement"](#) .

### 2. INSPECTION BETWEEN IPDM E/R AND FRONT FOG LAMPS

1. Disconnect IPDM E/R connector and inoperative front fog lamp connector.
2. Check continuity between harness connector terminals of IPDM E/R and harness connector terminal of front fog lamps.

IPDM E/R		Front fog lamp		Continuity
Connector	Terminal	Connector	Terminal	
E123	50	LH	E101	Yes
	51	RH	E102	

OK or NG

- OK >> Check ground circuit. If OK, replace IPDM E/R. Refer to [PG-33, "Removal and Installation of IPDM E/R"](#) . If NG, repair harness or connector.
- NG >> Check for short circuits and open circuits in harness between IPDM E/R and front fog lamps.

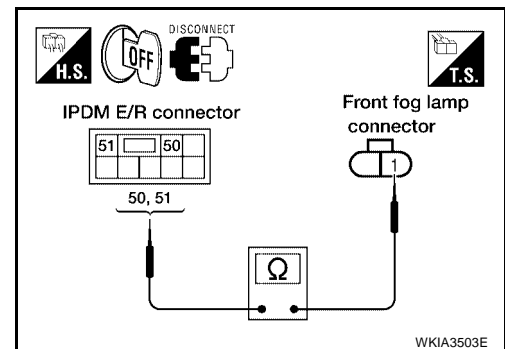

# FRONT FOG LAMP

## Aiming Adjustment

EKS00BQB

The fog lamp is a semi-sealed beam type which uses a replaceable halogen bulb. Before performing aiming adjustment, make sure of the following.

- Keep all tires inflated to correct pressure.
- Place vehicle on level ground.
- See that vehicle is unloaded (except for full levels of coolant, engine oil and fuel, and spare tire, jack, and tools). Have the driver or equivalent weight placed in driver seat.

Adjust aiming in the vertical direction by turning the adjustment screw.

### NOTE:

Use a Phillips screwdriver to adjust. Turn screw clockwise to raise pattern and counterclockwise to lower pattern.

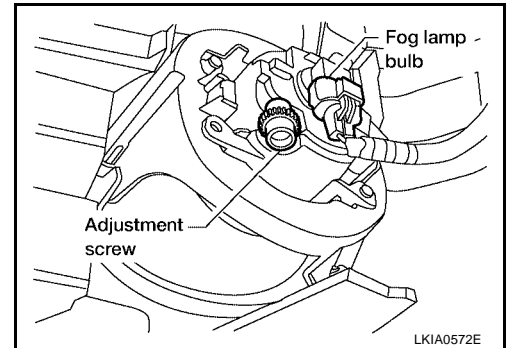

1. Set the distance between the screen and the center of the fog lamp lens as shown.

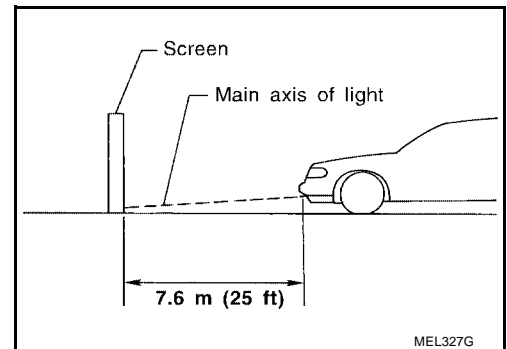

2. Turn front fog lamps ON.
3. Remove front portion of fender protector(s) for adjustment screw access. Refer to [EI-23, "Removal and Installation of Front Fender Protector"](#)
4. Adjust front fog lamps using adjustment screw so that the top edge of the high intensity zone is 100 mm (4 in) below the height of the fog lamp centers as shown.
  - When performing adjustment, if necessary, cover the headlamps and opposite fog lamp.

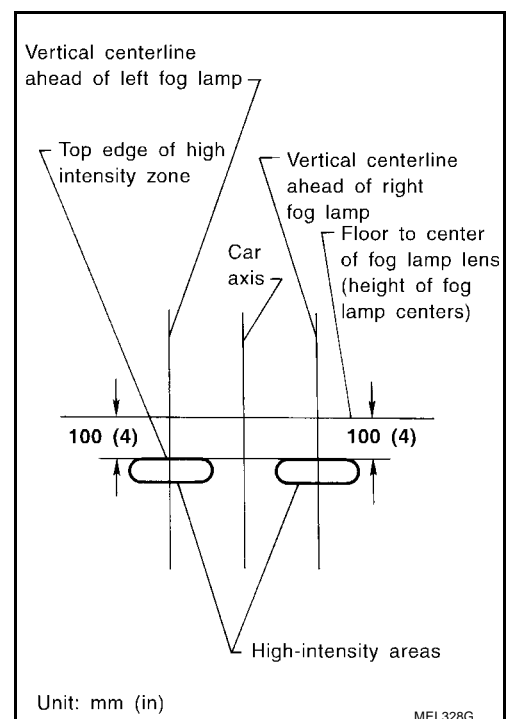

# FRONT FOG LAMP

EKS00BQC

## Bulb Replacement REMOVAL

1. Position front fender protector aside. Refer to [EI-22, "FENDER PROTECTOR"](#) .
2. Disconnect fog lamp connector.
3. Turn the bulb counterclockwise to remove it.

### CAUTION:

- Do not touch the glass of bulb directly by hand. Keep grease and other oily substances away from it. Do not touch bulb by hand while it is lit or right after being turned off. Burning may result.
- Do not leave bulb out of fog lamp reflector for a long time because dust, moisture smoke, etc. may affect the performance of fog lamp. When replacing bulb, be sure to replace it with new one.

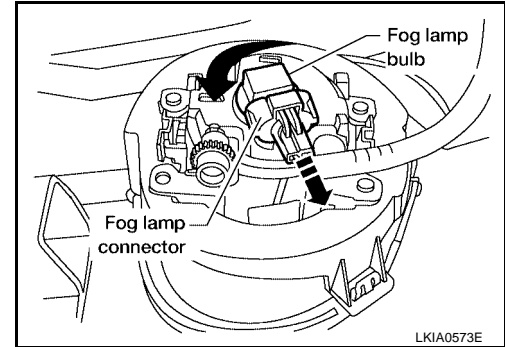

## INSTALLATION

Installation is in the reverse order of removal.

## Removal and Installation FOG LAMP

EKS00BQD

### Removal

The fog lamp is a semi-sealed beam type which uses a replaceable halogen bulb.

### CAUTION:

- Do not leave fog lamp assembly without bulb for a long period of time. Dust, moisture, smoke, etc. entering the fog lamp body may affect the performance. Remove the bulb from the headlamp assembly just before replacement bulb is installed.
  - Grasp only the plastic base when handling the bulb. Never touch the glass envelope. Touching the glass could significantly affect the bulb life and/or fog lamp performance.
1. Position front fender protector aside. Refer to [EI-23, "Removal and Installation of Front Fender Protector"](#)
  2. Disconnect fog lamp connector.
  3. Remove fog lamp screws and pull fog lamp rearward out of front bumper.

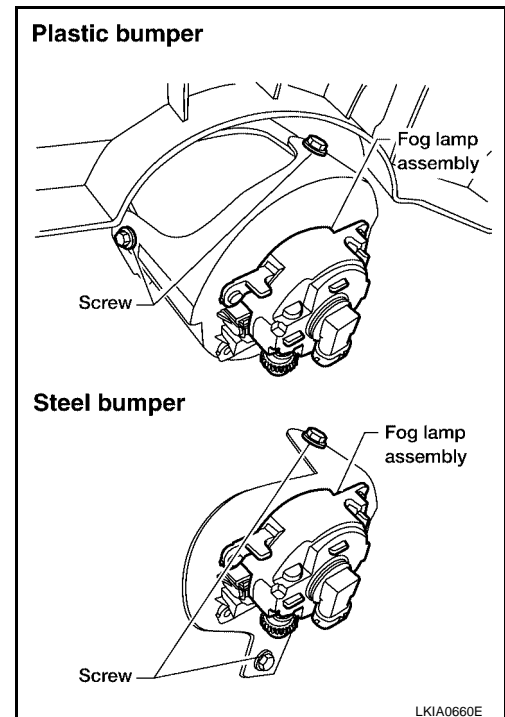

### Installation

Installation is in the reverse order of removal.

# TURN SIGNAL AND HAZARD WARNING LAMPS

PF:26120

## TURN SIGNAL AND HAZARD WARNING LAMPS

### Component Parts and Harness Connector Location

EKS00BQE

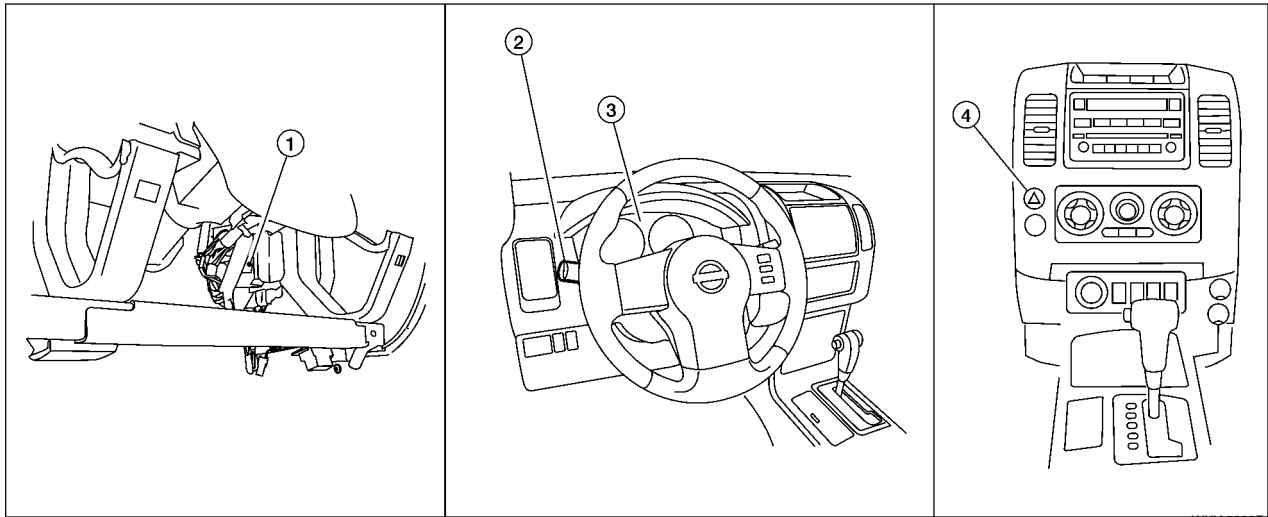

1. BCM  
M18, M20  
(view with lower instrument panel LH removed)
2. Combination switch (lighting switch)  
M28
3. Combination meter  
M24
4. Hazard switch  
M55

### System Description OUTLINE

EKS00CMV

Power is supplied at all times

- through 50A fusible link (letter **g** , located in the fuse and fusible link box)
- to BCM (body control module) terminal 70, and
- through 10A fuse [No. 19, located in the fuse block (J/B)]
- to combination meter terminal 3.

### TURN SIGNAL OPERATION

When the ignition switch is in the ON or START position, power is supplied

- through 10A fuse [No. 1, located in the fuse block (J/B)]
- to BCM terminal 38, and
- through 10A fuse [No. 14, located in the fuse block (J/B)]
- to combination meter terminal 16.

Ground is supplied

- to BCM terminal 67 and
- to combination meter terminals 13 and 23
- through grounds M57, M61 and M79.

### LH Turn

When the turn signal switch is moved to the left position, the BCM, interpreting it as turn signal is ON, outputs turn signal from BCM terminal 60.

The BCM supplies power

- through BCM terminal 60
- to front combination lamp LH (turn signal) terminal 6
- through front combination lamp LH (turn signal) terminal 5, and
- to rear combination lamp LH (turn signal) terminal 4
- through rear combination lamp LH (turn signal) terminal 5
- to grounds E9, E15 (all) and E24 (VQ40DE engine only).

A  
B  
C  
D  
E  
F  
G  
H  
I  
J  
LT  
L  
M

# TURN SIGNAL AND HAZARD WARNING LAMPS

BCM sends signal to combination meter through CAN communication lines and turns on turn signal indicator lamp within combination meter.

## RH Turn

When the turn signal switch is moved to the right position, the BCM, interpreting it as turn signal is ON, outputs turn signal from BCM terminal 61.

The BCM supplies power

- through BCM terminal 61
- to front combination lamp RH (turn signal) terminal 6
- through front combination lamp RH (turn signal) terminal 5, and
- to rear combination lamp RH (turn signal) terminal 4
- through rear combination lamp RH (turn signal) terminal 5
- to grounds E9, E15 (all) and E24 (VQ40DE engine only).

BCM sends signal to combination meter through CAN communication lines, and turns on turn signal indicator lamp within combination meter.

## HAZARD LAMP OPERATION

Power is supplied at all times

- through 50A fusible link (letter **g** , located in the fuse and fusible link box)
- to BCM terminal 70, and
- through 10A fuse [No. 19, located in the fuse block (J/B)]
- to combination meter terminal 3.

Ground is supplied

- to BCM terminal 67 and
- to combination meter terminals 13 and 23
- through grounds M57, M61 and M79.

When the hazard switch is depressed, ground is supplied

- to BCM terminal 29
- through hazard switch terminal 2
- through hazard switch terminal 1
- through grounds M57, M61 and M79.

When the hazard switch is depressed, the BCM, interpreting it as turn signal is ON, outputs turn signal from BCM terminals 60 and 61.

The BCM supplies power

- through BCM terminals 60 and 61
- to front combination lamp LH and RH (turn signal) terminal 6
- through front combination lamp LH and RH (turn signal) terminal 5, and
- to rear combination lamp LH and RH (turn signal) terminal 4
- through rear combination lamp LH and RH (turn signal) terminal 5
- to grounds E9, E15 (all) and E24 (VQ40DE engine only).

BCM sends signal to combination meter through CAN communication lines and turns on turn signal indicator lamps within combination meter.

## REMOTE KEYLESS ENTRY SYSTEM OPERATION

Power is supplied at all times

- through 50A fusible link (letter **g** , located in the fuse and fusible link box)
- to BCM terminal 70, and
- through 10A fuse [No. 19, located in the fuse block (J/B)]
- to combination meter terminal 3.

Ground is supplied

- to BCM terminal 67 and
- to combination meter terminals 13 and 23



# TURN SIGNAL AND HAZARD WARNING LAMPS

- through grounds M57, M61 and M79.

When the remote keyless entry system is triggered by input from the keyfob, the BCM, interpreting it as turn signal is ON, outputs turn signal from BCM terminals 60 and 61.

The BCM supplies power

- through BCM terminals 60 and 61
- to front combination lamp LH and RH (turn signal) terminal 6
- through front combination lamp LH and RH (turn signal) terminal 5, and
- to rear combination lamp LH and RH (turn signal) terminal 4
- through rear combination lamp LH and RH (turn signal) terminal 5
- to grounds E9, E15 (all) and E24 (VQ40DE engine only).

BCM sends signal to combination meter through CAN communication lines, and turns on turn signal indicator lamps within combination meter.

With power and input supplied, the BCM controls the flashing of the hazard warning lamps when keyfob is used to activate the remote keyless entry system.

## COMBINATION SWITCH READING FUNCTION

Refer to [BCS-3, "COMBINATION SWITCH READING FUNCTION"](#) .

## CAN Communication System Description

Refer to [LAN-22, "CAN COMMUNICATION"](#) .

A

B

C

D

E

F

EKS00BQG

G

H

I

J

LT

L

M

# TURN SIGNAL AND HAZARD WARNING LAMPS

EKS00BQH

## Wiring Diagram — TURN —

LT-TURN-01

— : DATA LINE

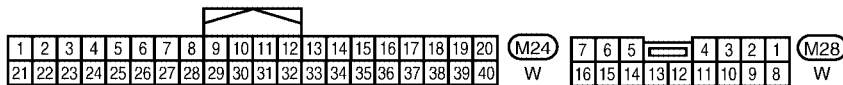
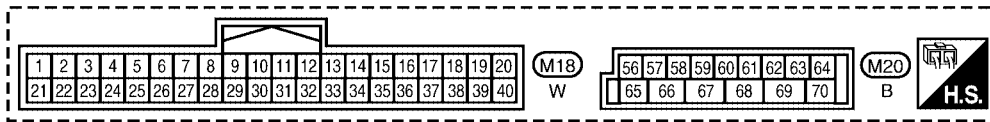
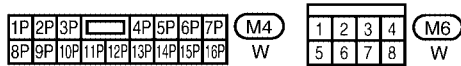
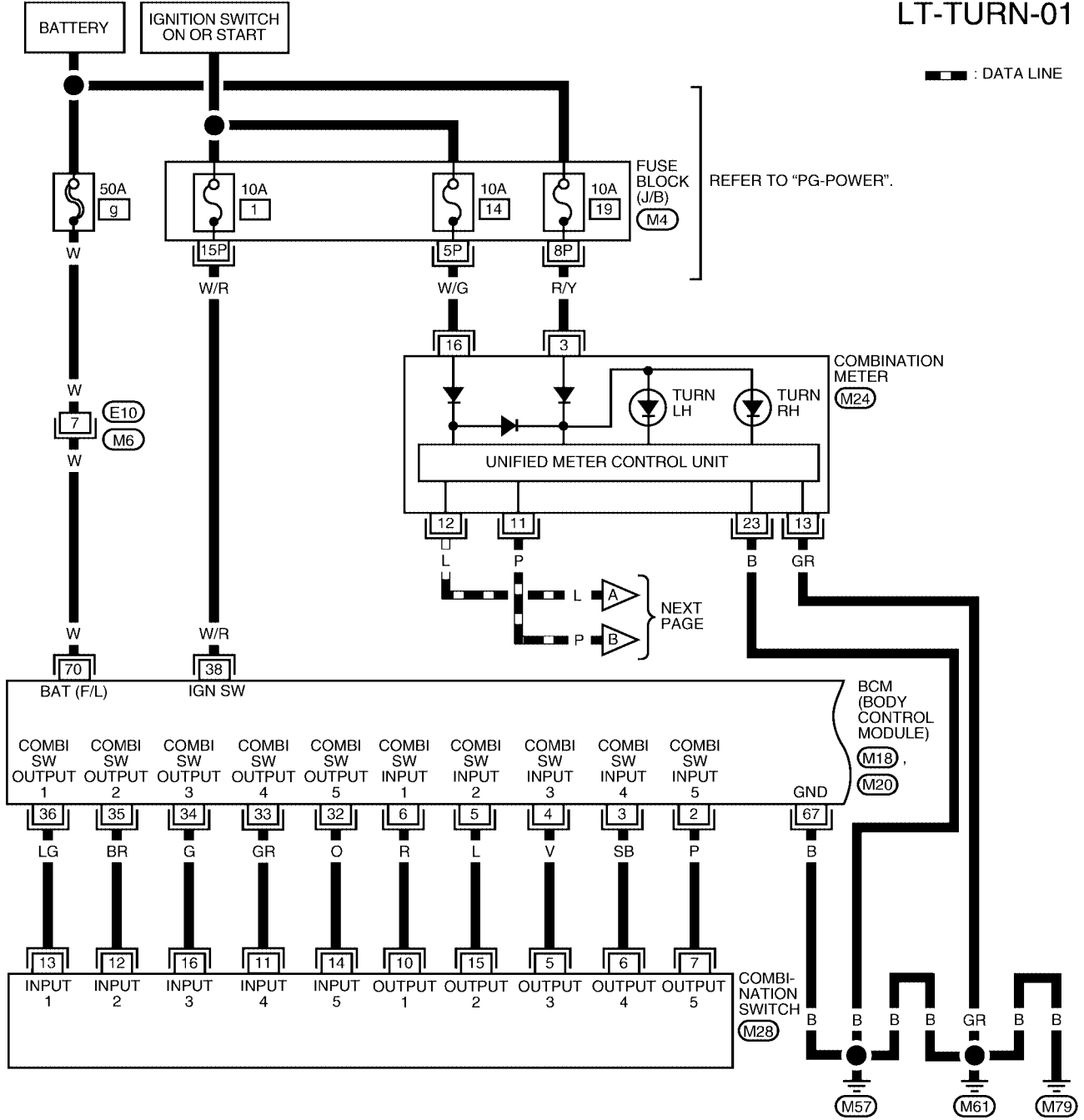

WKWA4358E

# TURN SIGNAL AND HAZARD WARNING LAMPS

LT-TURN-02

— : DATA LINE  
 ZV : WITH VQ40DE

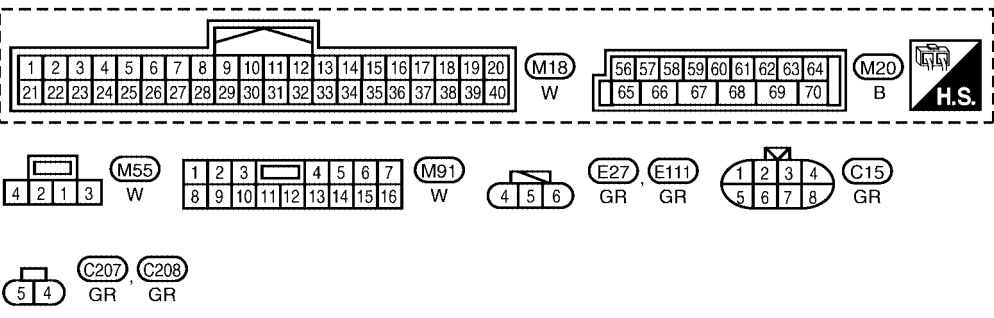
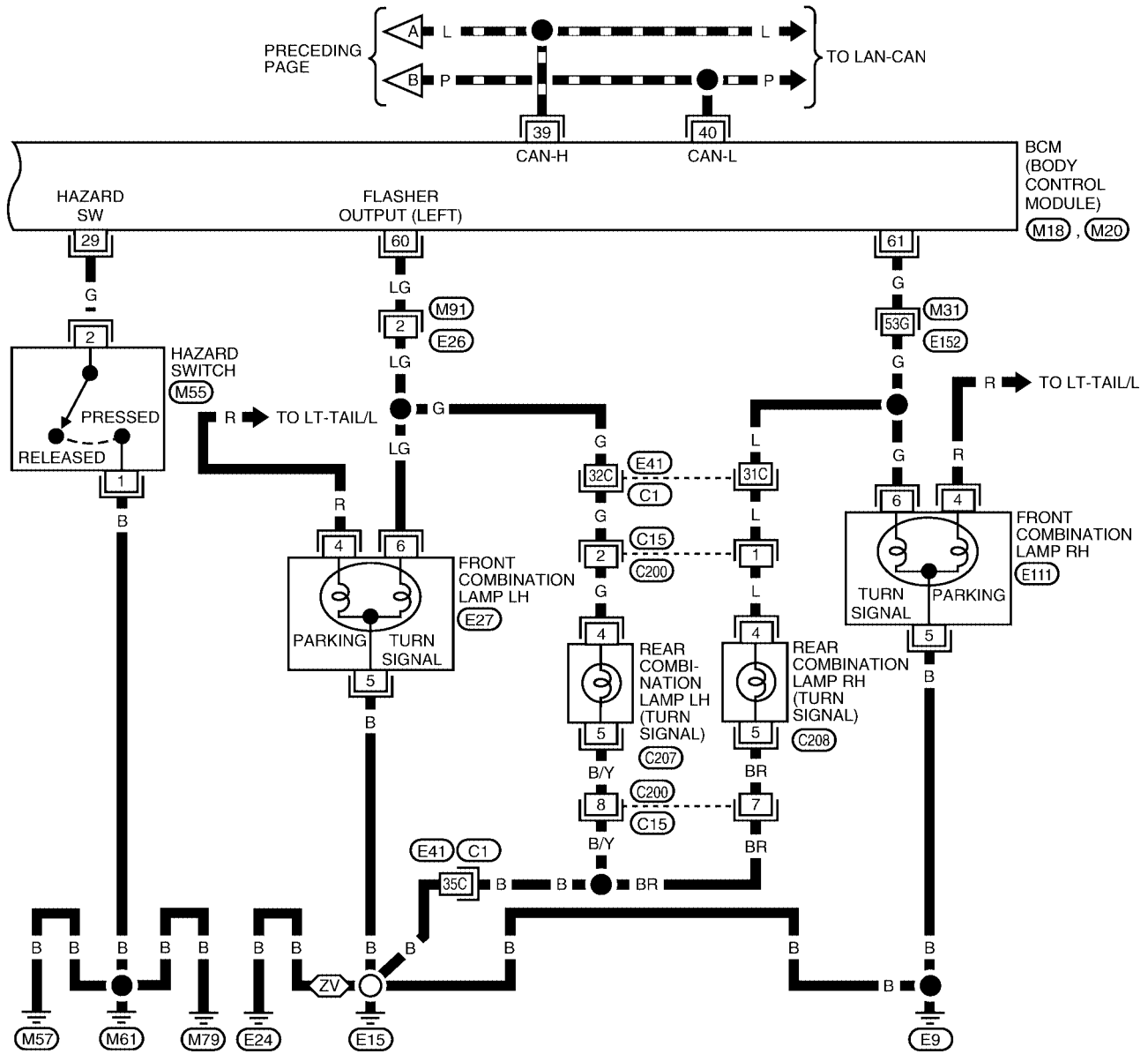

REFER TO THE FOLLOWING.  
 (M31), (C1) - SUPER  
 MULTIPLE JUNCTION (SMJ)

WKWA4359E

# TURN SIGNAL AND HAZARD WARNING LAMPS

## Terminals and Reference Values for BCM

EKS00CMW

Refer to [BCS-12, "Terminals and Reference Values for BCM"](#).

## How to Proceed With Trouble Diagnosis

EKS00CMX

1. Confirm the symptom or customer complaint.
2. Understand operation description and function description. Refer to [LT-63, "System Description"](#).
3. Perform preliminary check. Refer to [LT-68, "Preliminary Check"](#).
4. Check symptom and repair or replace the cause of malfunction.
5. Do turn signal and hazard warning lamps operate normally? If YES: GO TO 6. If NO: GO TO 4.
6. Inspection End.

## Preliminary Check

EKS00CMY

### CHECK POWER SUPPLY AND GROUND CIRCUIT

Refer to [BCS-16, "BCM Power Supply and Ground Circuit Check"](#).

## CONSULT-II Function (BCM)

EKS00CMZ

CONSULT-II can display each diagnostic item using the diagnostic test modes shown following.

BCM diagnostic test item	Diagnostic mode	Description
Inspection by part	WORK SUPPORT	Supports inspections and adjustments. Commands are transmitted to the BCM for setting the status suitable for required operation, input/output signals are received from the BCM and received data is displayed.
	DATA MONITOR	Displays BCM input/output data in real time.
	ACTIVE TEST	Operation of electrical loads can be checked by sending drive signal to them.
	SELF-DIAG RESULTS	Displays BCM self-diagnosis results.
	CAN DIAG SUPPORT MNTR	The result of transmit/receive diagnosis of CAN communication can be read.
	ECU PART NUMBER	BCM part number can be read.
	CONFIGURATION	Performs BCM configuration read/write functions.

## CONSULT-II OPERATION

### CAUTION:

If CONSULT-II is used with no connection of CONSULT-II CONVERTER, malfunctions might be detected in self-diagnosis depending on control unit which carries out CAN communication.

1. With the ignition switch OFF, connect CONSULT-II and CONSULT-II CONVERTER to the data link connector, then turn ignition switch ON.

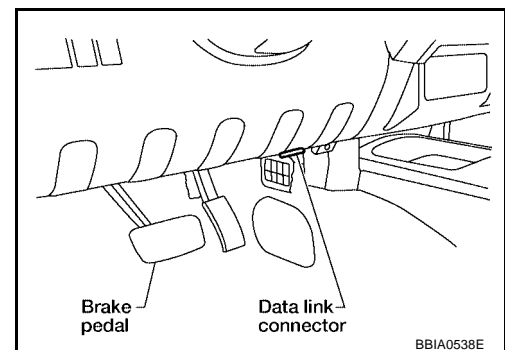

# TURN SIGNAL AND HAZARD WARNING LAMPS

2. Touch "START (NISSAN BASED VHCL)".

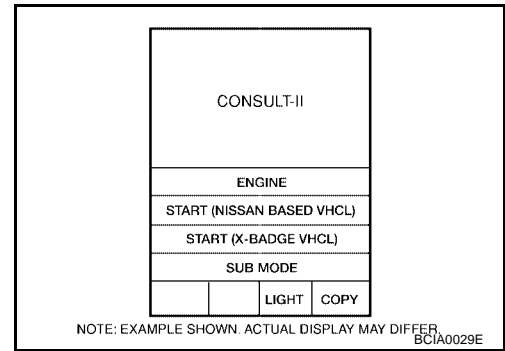

3. Touch "BCM" on "SELECT SYSTEM" screen.  
If "BCM" is not indicated, go to [GI-41, "CONSULT-II Data Link Connector \(DLC\) Circuit"](#).

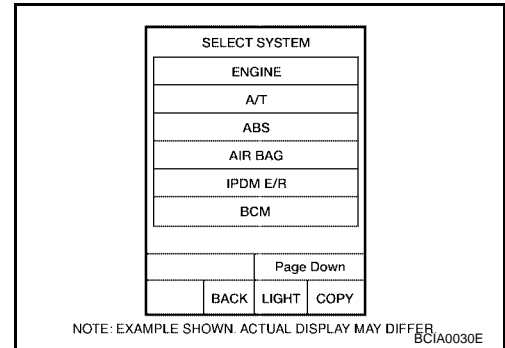

4. Touch "FLASHER" on "SELECT TEST ITEM" screen.

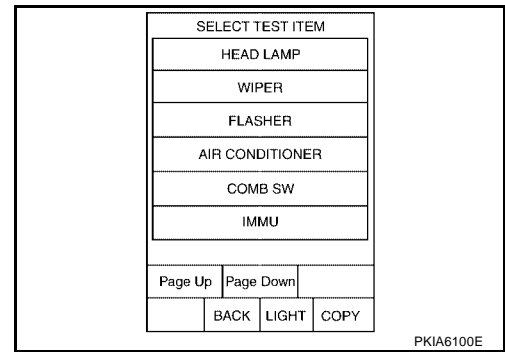

## DATA MONITOR

### Operation Procedure

1. Touch "FLASHER" on "SELECT TEST ITEM" screen.
2. Touch "DATA MONITOR" on "SELECT DIAG MODE" screen.
3. Touch either "ALL SIGNALS" or "SELECTION FROM MENU" on the "SELECT MONITOR ITEM" screen.

ALL SIGNALS	Monitors all the signals.
SELECTION FROM MENU	Selects and monitors the individual signal.

4. Touch "START".
5. When "SELECTION FROM MENU" is selected, touch items to be monitored. When "ALL SIGNALS" is selected, all the items will be monitored.
6. Touch "RECORD" while monitoring, then the status of the monitored item can be recorded. To stop recording, touch "STOP".

### Display Item List

Monitor item	Contents
IGN ON SW "ON/OFF"	Displays "IGN position (ON)/OFF, ACC position (OFF)" judged from the ignition switch signal.
HAZARD SW "ON/OFF"	Displays "Hazard ON (ON)/Hazard OFF (OFF)" status, determined from hazard switch signal.

# TURN SIGNAL AND HAZARD WARNING LAMPS

Monitor item	Contents
TURN SIGNAL R "ON/OFF"	Displays "Turn right (ON)/Other (OFF)" status, determined from lighting switch signal.
TURN SIGNAL L "ON/OFF"	Displays "Turn left (ON)/Other (OFF)" status, determined from lighting switch signal.
BRAKE SW "ON/OFF"	Displays status of stop lamp switch.

## ACTIVE TEST

### Operation Procedure

1. Touch "FLASHER" on "SELECT TEST ITEM" screen.
2. Touch "ACTIVE TEST" on "SELECT DIAG MODE" screen.
3. Touch item to be tested and check operation of the selected item.
4. During the operation check, touching "BACK" or "OFF" deactivates the operation.

### Display Item List

Test item	Description
FLASHER (RH)	Turn signal lamp (right) can be operated by any ON-OFF operations.
FLASHER (LH)	Turn signal lamp (left) can be operated by any ON-OFF operations.

## Turn Signal Lamp Does Not Operate

EKS00CNO

### 1. CHECK COMBINATION SWITCH INPUT SIGNAL

Ⓟ With CONSULT-II

Select "BCM" on CONSULT-II. With "FLASHER" data monitor, make sure "TURN SIGNAL R" and "TURN SIGNAL L" turns ON-OFF linked with operation of lighting switch.

**When lighting switch is in : TURN SIGNAL R ON  
TURN RH position**

**When lighting switch is in : TURN SIGNAL L ON  
TURN LH position**

ⓧ Without CONSULT-II

Refer to [LT-81, "Combination Switch Inspection"](#) .

OK or NG

OK >> GO TO 2.

NG >> Check lighting switch. Refer to [LT-81, "Combination Switch Inspection"](#) .

DATA MONITOR	
MONITOR	
TURN SIGNAL R	ON
TURN SIGNAL L	ON

SKIA4499E

### 2. ACTIVE TEST

Ⓟ With CONSULT-II

1. Select "FLASHER" during active test. Refer to [LT-70, "ACTIVE TEST"](#) .
2. Make sure "FLASHER RH" and "FLASHER LH" operate.

ⓧ Without CONSULT-II

GO TO 3.

OK or NG

OK >> Replace BCM. Refer to [BCS-26, "Removal and Installation"](#) .

NG >> GO TO 3.

ACTIVE TEST			
FLASHER		OFF	
RH	LH		
MODE	BACK	LIGHT	COPY

SKIA6190E

# TURN SIGNAL AND HAZARD WARNING LAMPS

## 3. CHECK TURN SIGNAL LAMPS CIRCUIT

1. Turn ignition switch OFF.
2. Disconnect BCM connector and front combination lamp LH and RH (turn signal) connectors.
3. Check continuity between BCM harness connector M20 terminal 60 and front combination lamp LH (turn signal) harness connector E27 terminal 6.

**60 - 6** : Continuity should exist.

4. Check continuity between BCM harness connector M20 terminal 61 and front combination lamp RH (turn signal) harness connector E111 terminal 6.

**61 - 6** : Continuity should exist.

OK or NG

OK >> GO TO 4.

NG >> Repair harness or connector.

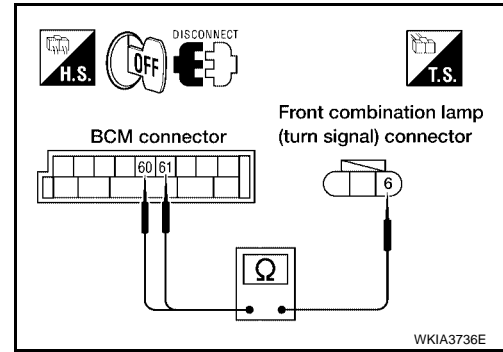

## 4. CHECK GROUND

1. Check continuity between front combination lamp LH (turn signal) harness connector E27 terminal 5 and ground.

**5 - Ground** : Continuity should exist.

2. Check continuity between front combination lamp RH (turn signal) harness connector E111 terminal 5 and ground.

**5 - Ground** : Continuity should exist.

OK or NG

OK >> GO TO 5.

NG >> Repair harness or connector.

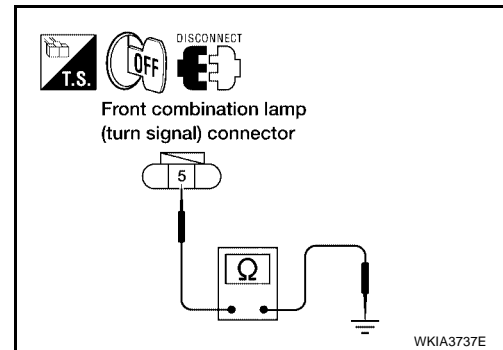

## 5. CHECK BULB

Check bulb standard of each turn signal lamp is correct. Refer to [LT-158, "Exterior Lamp"](#) .

OK or NG

OK >> Replace BCM if turn signal lamps do not work after setting the connector again. Refer to [BCS-26, "Removal and Installation"](#) .

NG >> Replace turn signal lamp bulb. Refer to [LT-27, "FRONT TURN SIGNAL/PARKING LAMP"](#) .

## Rear Turn Signal Lamp Does Not Operate

EKS00CN1

### 1. CHECK TAIL LAMPS AND STOP LAMPS

Check bulb standard of each turn signal lamp is correct. Refer to [LT-158, "Exterior Lamp"](#) .

OK or NG

OK >> GO TO 2.

NG >> Replace turn signal lamp bulb. Refer to [LT-105, "Bulb Replacement"](#) .

# TURN SIGNAL AND HAZARD WARNING LAMPS

## 2. CHECK TURN SIGNAL LAMPS CIRCUIT

1. Disconnect BCM connector and rear combination lamp connector.
2. Check continuity between BCM harness connector M20 terminal 60 and rear combination lamp LH (turn signal) harness connector C207 terminal 4.

**60 - 4** : Continuity should exist.

3. Check continuity between BCM harness connector M20 terminal 61 and rear combination lamp RH (turn signal) harness connector C208 terminal 4.

**61 - 4** : Continuity should exist.

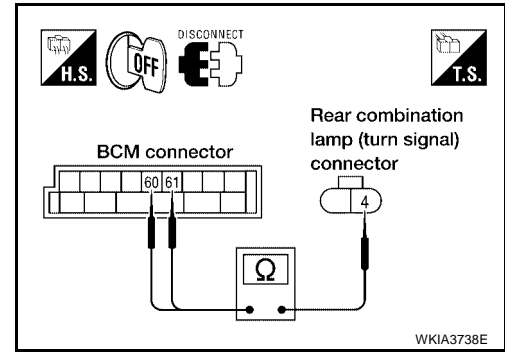

OK or NG

- OK >> GO TO 3.
- NG >> Repair harness or connector.

## 3. CHECK GROUND CIRCUIT

Check continuity between rear combination lamp (turn signal) harness connector C207 (LH) and C208 (RH) terminal 5 and ground.

**5 - Ground** : Continuity should exist.

OK or NG

- OK >> Check rear combination lamp connector for proper connection. Repair as necessary.
- NG >> Repair harness or connector.

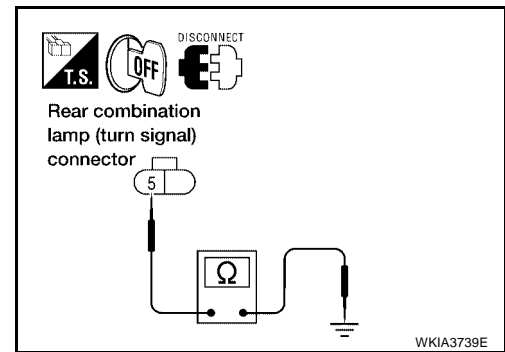

## Hazard Warning Lamp Does Not Operate But Turn Signal Lamps Operate

EKS00CN2

### 1. CHECK BULB

Make sure bulb standard of each turn signal lamp is correct. Refer to [LT-158, "Exterior Lamp"](#).

OK or NG

- OK >> GO TO 2.
- NG >> Replace turn signal lamp bulb. Refer to [LT-27, "FRONT TURN SIGNAL/PARKING LAMP"](#) for front turn signal bulb. Refer to [LT-105, "Bulb Replacement"](#) for rear turn signal bulb.



# TURN SIGNAL AND HAZARD WARNING LAMPS

## 2. CHECK HAZARD SWITCH INPUT SIGNAL

Ⓜ With CONSULT-II  
Select "BCM" on CONSULT-II. With "FLASHER" data monitor, make sure "HAZARD SW" turns ON-OFF linked with operation of hazard switch.

**When hazard switch is in : HAZARD SW ON ON position**

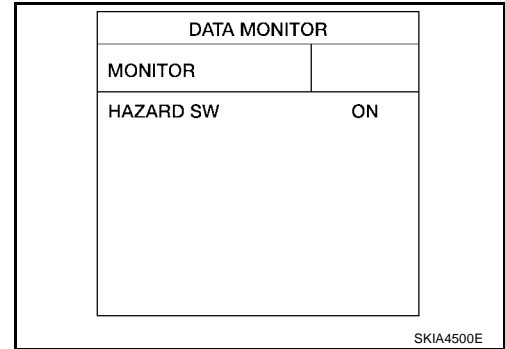

⊗ Without CONSULT-II  
Check voltage between BCM harness connector M18 terminal 29 and ground.

BCM (+)		(-)	Condition	Voltage (Approx.)
Connector	Terminal			
M18	29	Ground	Hazard switch is ON	0V
			Hazard switch is OFF	5V

OK or NG

- OK >> Replace BCM. Refer to [BCS-26, "Removal and Installation"](#).
- NG >> GO TO 3.

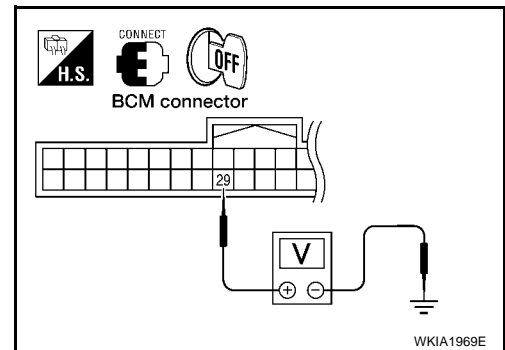

## 3. CHECK HAZARD SWITCH CIRCUIT

1. Turn ignition switch OFF.
2. Disconnect BCM connector and hazard switch connector.
3. Check continuity between BCM harness connector M18 terminal 29 and hazard switch harness connector M55 terminal 2.

**29 - 2 : Continuity should exist.**

OK or NG

- OK >> GO TO 4.
- NG >> Repair harness or connector.

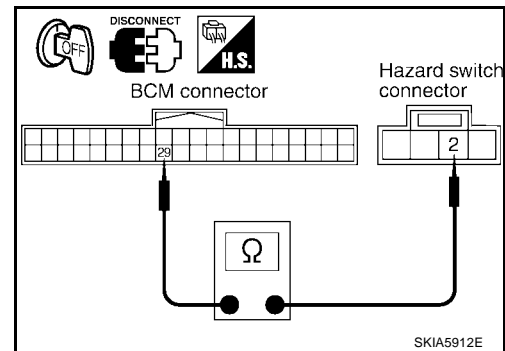

## 4. CHECK GROUND

Check continuity between hazard switch harness connector M55 terminal 1 and ground.

**1 - Ground : Continuity should exist.**

OK or NG

- OK >> GO TO 5.
- NG >> Repair harness or connector.

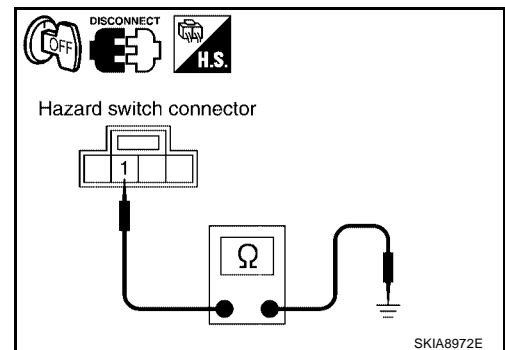

# TURN SIGNAL AND HAZARD WARNING LAMPS

## 5. CHECK HAZARD SWITCH

1. Disconnect hazard switch connector.
2. Check continuity of hazard switch.

Hazard switch		Condition	Continuity
Terminal			
2	1	Hazard switch is ON	Yes
		Hazard switch is OFF	No

OK or NG

OK >> Replace BCM if turn signal lamps does not work after setting the connector again. Refer to [BCS-26, "Removal and Installation"](#) .

NG >> Replace hazard switch. Refer to [LT-77, "Removal and Installation"](#) .

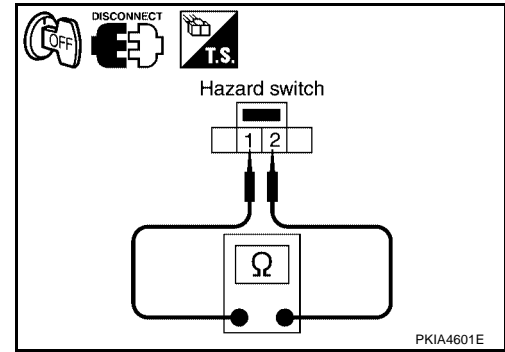

## Turn Signal Indicator Lamp Does Not Operate

EKS00CN3

### 1. CHECK CAN COMMUNICATION SYSTEM

Check CAN communication. Refer to [LAN-22, "CAN COMMUNICATION"](#) .

OK or NG

OK >> Replace combination meter. Refer to [IP-13, "COMBINATION METER"](#) .

NG >> Repair as necessary.

# TURN SIGNAL AND HAZARD WARNING LAMPS

## Bulb Replacement

### FRONT TURN SIGNAL LAMP

Refer to [LT-27, "FRONT TURN SIGNAL/PARKING LAMP"](#) .

### REAR TURN SIGNAL LAMP

Refer to [LT-105, "REAR COMBINATION LAMP"](#) .

## Removal and Installation

### FRONT TURN SIGNAL LAMP

Refer to [LT-27, "FRONT COMBINATION LAMP"](#) .

### REAR TURN SIGNAL LAMP

Refer to [LT-105, "Removal and Installation"](#) .

EKS00BQQ

A

B

EKS00BQS

C

D

E

F

G

H

I

J

LT

L

M

# LIGHTING AND TURN SIGNAL SWITCH

## LIGHTING AND TURN SIGNAL SWITCH

PF2:25540

### Removal and Installation

EKS00BQU

#### REMOVAL

1. Remove lower instrument panel LH. Refer to [IP-12, "LOWER INSTRUMENT PANEL LH"](#) .
2. Remove knee protector brace.
3. Remove steering column cover.
4. Disconnect the lighting and turn signal switch connector.
5. While pressing tabs, pull lighting and turn signal switch toward driver door and release from the steering column.

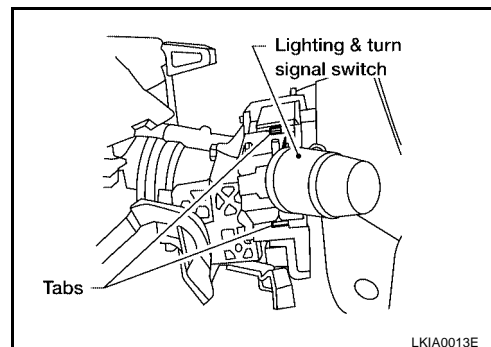

#### INSTALLATION

Installation is in the reverse order of removal.

# HAZARD SWITCH

PFP:25290

## HAZARD SWITCH

### Removal and Installation

EKS00BQV

#### REMOVAL

1. Remove cluster lid C. Refer to [IP-11, "CLUSTER LID C"](#).
2. Disconnect the hazard switch connector.
3. Remove the screws and remove the hazard switch.

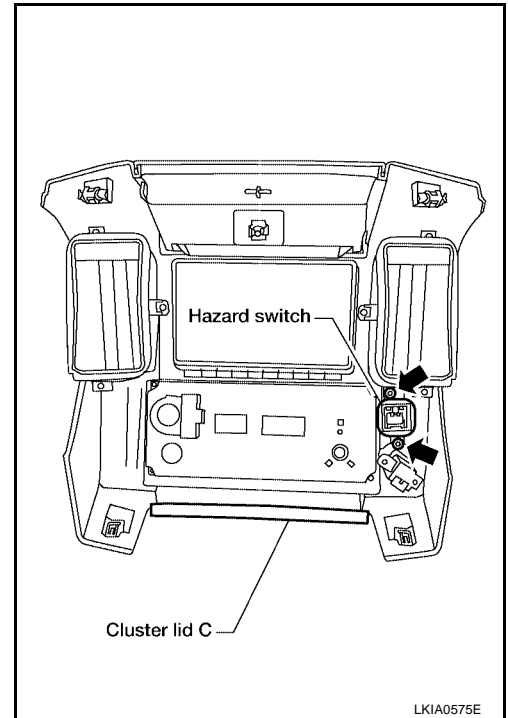

#### INSTALLATION

Installation is in the reverse order of removal.

A  
B  
C  
D  
E  
F  
G  
H  
I  
J  
LT  
L  
M

# COMBINATION SWITCH

PFP:25567

EKS00B0W

## COMBINATION SWITCH

### Wiring Diagram — COMBSW —

## LT-COMBSW-01

▬ : DATA LINE

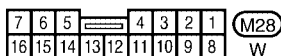
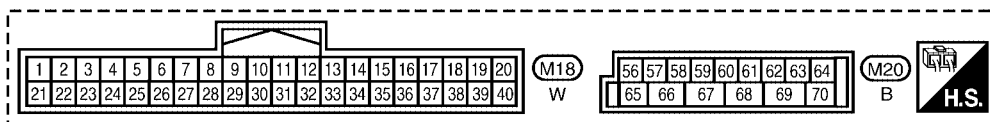
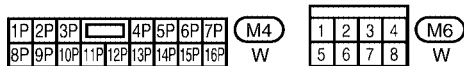
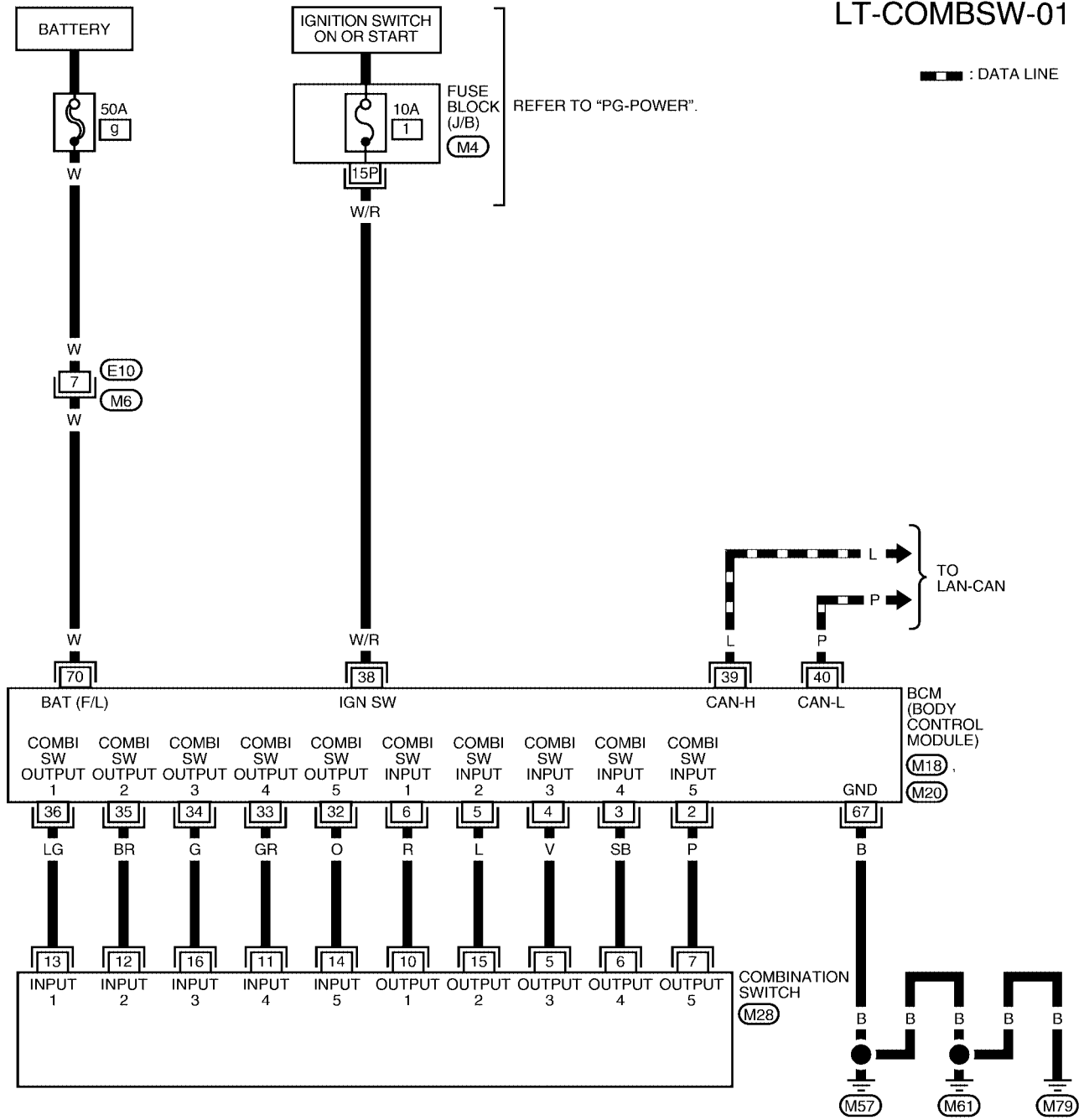

WKWA4360E

# COMBINATION SWITCH

## Combination Switch Reading Function

EKS00C48

For details, refer to [BCS-3, "COMBINATION SWITCH READING FUNCTION"](#).

## CONSULT-II Function (BCM)

EKS00CN4

CONSULT-II can display each diagnostic item using the diagnostic test modes shown following.

BCM diagnostic test item	Diagnostic mode	Description
Inspection by part	WORK SUPPORT	Supports inspections and adjustments. Commands are transmitted to the BCM for setting the status suitable for required operation, input/output signals are received from the BCM and received data is displayed.
	DATA MONITOR	Displays BCM input/output data in real time.
	ACTIVE TEST	Operation of electrical loads can be checked by sending drive signal to them.
	SELF-DIAG RESULTS	Displays BCM self-diagnosis results.
	CAN DIAG SUPPORT MNTR	The result of transmit/receive diagnosis of CAN communication can be read.
	ECU PART NUMBER	BCM part number can be read.
	CONFIGURATION	Performs BCM configuration read/write functions.

## CONSULT-II OPERATION

### CAUTION:

If CONSULT-II is used with no connection of CONSULT-II CONVERTER, malfunctions might be detected in self-diagnosis depending on control unit which carries out CAN communication.

1. With the ignition switch OFF, connect CONSULT-II and CONSULT-II CONVERTER to the data link connector, then turn ignition switch ON.

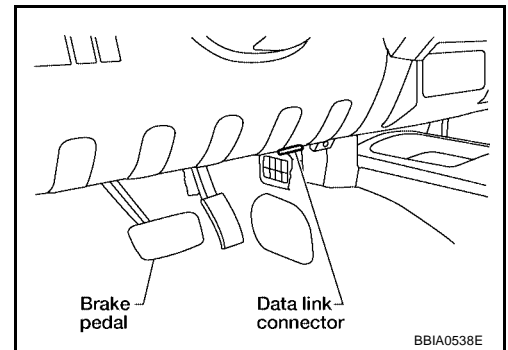

2. Touch "START (NISSAN BASED VHCL)".

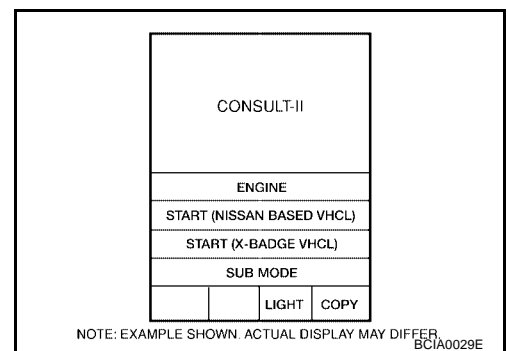

3. Touch "BCM" on "SELECT SYSTEM" screen. If "BCM" is not indicated, go to [GI-41, "CONSULT-II Data Link Connector \(DLC\) Circuit"](#).

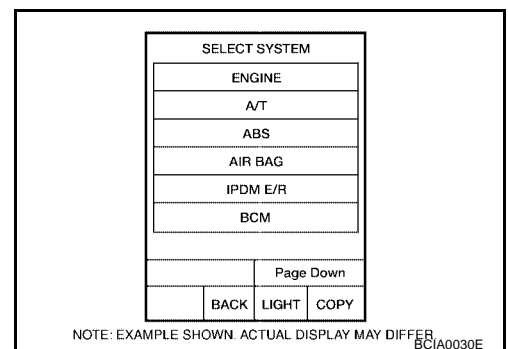

# COMBINATION SWITCH

4. Touch "COMB SW" on "SELECT TEST ITEM" screen.

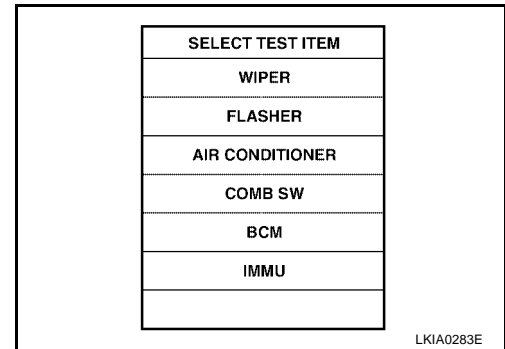

## DATA MONITOR

### Operation Procedure

1. Touch "COMB SW" on "SELECT TEST ITEM" screen.
2. Touch "DATA MONITOR" on "SELECT DIAG MODE" screen.
3. Touch either "ALL SIGNALS" or "SELECTION FROM MENU" on "SELECT MONITOR ITEM" screen.

ALL SIGNALS	Monitors all the signals.
SELECTION FROM MENU	Selects and monitors individual signal.

4. Touch "START".
5. When "SELECTION FROM MENU" is selected, touch items to be monitored. When "ALL SIGNALS" is selected, all the signals will be monitored.
6. Touch "RECORD" while monitoring, then the status of the monitored item can be recorded. To stop recording, touch "STOP".

### Display Item List

Monitor item name "OPERATION OR UNIT"	Contents
TURN SIGNAL R "ON/OFF"	Displays "Turn Right (ON)/Other (OFF)" status, determined from lighting switch signal.
TURN SIGNAL L "ON/OFF"	Displays "Turn Left (ON)/Other (OFF)" status, determined from lighting switch signal.
HI BEAM SW "ON/OFF"	Displays status (high beam switch: ON/Others: OFF) of high beam switch judged from lighting switch signal.
HEAD LAMP SW 1 "ON/OFF"	Displays "Headlamp switch 1 (ON)/Other (OFF)" status, determined from lighting switch signal.
HEAD LAMP SW 2 "ON/OFF"	Displays status (headlamp switch 2: ON/Others: OFF) of headlamp switch 2 judged from lighting switch signal.
LIGHT SW 1ST "ON/OFF"	Displays status (lighting switch 1st position: ON/Others: OFF) of lighting switch judged from lighting switch signal.
PASSING SW "ON/OFF"	Displays status (flash-to-pass switch: ON/Others: OFF) of flash-to-pass switch judged from lighting switch signal.
AUTO LIGHT SW "ON/OFF"	Displays "Auto light switch (ON)/Other (OFF)" status, determined from lighting switch signal.
FR FOG SW "ON/OFF"	Displays "Front fog lamp switch (ON)/Other (OFF)" status, determined from lighting switch signal.
FR WIPER HI "ON/OFF"	Displays "Front Wiper HI (ON)/Other (OFF)" status, determined from wiper switch signal.
FR WIPER LOW "ON/OFF"	Displays "Front Wiper LOW (ON)/Other (OFF)" status, determined from wiper switch signal.
FR WIPER INT "ON/OFF"	Displays "Front Wiper INT (ON)/Other (OFF)" status, determined from wiper switch signal.
FR WASHER SW "ON/OFF"	Displays "Front Washer Switch (ON)/Other (OFF)" status, determined from wiper switch signal.
INT VOLUME [1 - 7]	Displays intermittent operation knob setting (1 - 7), determined from wiper switch signal.
RR WIPER ON "ON/OFF"	Displays "Rear Wiper (ON)/(OFF)" status, determined from wiper switch signal.
RR WIPER INT "ON/OFF"	Displays "Rear Wiper INT (ON)/(OFF)" status, determined from wiper switch signal.
RR WASHER SW "ON/OFF"	Displays "Rear Washer (ON)/(OFF)" status, determined from wiper switch signal.



# COMBINATION SWITCH

EKS00CN5

## Combination Switch Inspection

### 1. SYSTEM CHECK

Referring to table below, check to which system the malfunctioning switch belongs.

System 1	System 2	System 3	System 4	System 5
—	FR WASHER	FR WIPER LO	TURN LH	TURN RH
FR WIPER HI	—	FR WIPER INT	PASSING	HEAD LAMP1
INT VOLUME 1	—	—	HEAD LAMP2	HI BEAM
—	INT VOLUME 3	AUTO LIGHT	—	TAIL LAMP
INT VOLUME 2	—	—	FR FOG	—

>> GO TO 2.

### 2. SYSTEM CHECK

 With CONSULT-II

#### CAUTION:

If CONSULT-II is used with no connection of CONSULT-II CONVERTER, malfunctions might be detected in self-diagnosis depending on control unit which carries out CAN communication.

1. Connect CONSULT-II, and select "COMB SW" on "SELECT TEST ITEM" screen.
2. Select "DATA MONITOR".
3. Select "START", and confirm that other switches in malfunctioning system operate normally.

Example: When auto light switch is malfunctioning, confirm that "FRONT WIPER LOW" and "FRONT WIPER INT" in System 3, to which the auto light switch belongs, turn ON-OFF normally.

DATA MONITOR	
MONITOR	
TURN SIGNAL R	OFF
TURN SIGNAL L	OFF
HIBEAM SW	OFF
HEAD LAMP SW1	OFF
HEAD LAMP SW2	OFF
LIGHT SW 1ST	OFF
PASSING SW	OFF
AUTO LIGHT SW	OFF
FR FOG SW	OFF
	Page Down
	RECORD
MODE	BACK
LIGHT	COPY

SKIA7075E

 Without CONSULT-II

Operate combination switch, and confirm that other switches in malfunctioning system operate normally.

Example: When auto light switch is malfunctioning, confirm that "FRONT WIPER LOW" and "FRONT WIPER INT" in System 3, to which the auto light switch belongs, operate normally.

#### Check results

Other switches in malfunctioning system operate normally.>>Replace lighting switch or wiper switch.

Other switches in malfunctioning system do not operate normally.>>GO TO 3.

# COMBINATION SWITCH

## 3. HARNESS INSPECTION

1. Turn ignition switch OFF.
2. Disconnect BCM and combination switch connectors.
3. Check for continuity between BCM harness connector of the suspect system and the corresponding combination switch connector terminals.

Suspect system	BCM		Combination switch		Continuity
	Connector	Terminal	Connector	Terminal	
1	M18	Input 1	6	M28	10
		Output 1	36		13
2		Input 2	5		15
		Output 2	35		12
3		Input 3	4		5
		Output 3	34		16
4		Input 4	3		6
		Output 4	33		11
5		Input 5	2		7
		Output 5	32		14

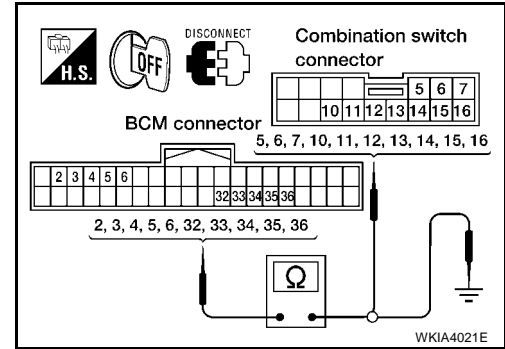

4. Check for continuity between each terminal of BCM harness connector in suspect malfunctioning system and ground.

Suspect system	BCM		Continuity		
	Connector	Terminal			
1	M18	Input 1	6	Ground	No
		Output 1	36		
2		Input 2	5		
		Output 2	35		
3		Input 3	4		
		Output 3	34		
4		Input 4	3		
		Output 4	33		
5		Input 5	2		
		Output 5	32		

OK or NG

OK >> GO TO 4.

NG >> Check harness between BCM and combination switch for open or short circuit.

# COMBINATION SWITCH

## 4. BCM OUTPUT TERMINAL INSPECTION

1. Turn ignition switch ON.
2. Turn lighting switch and wiper switch to OFF.
3. Set wiper dial to position 4.
4. Connect BCM and combination switch connectors, and check BCM output terminal voltage waveform of suspect malfunctioning system.

Suspect system	Combination switch	
	(+)	
	Connector	Terminal
1	M28	Output 1 13
2		Output 2 12
3		Output 3 16
4		Output 4 11
5		Output 5 14

OK or NG

- OK >> Open circuit in combination switch, GO TO 5.  
 NG >> Replace BCM. Refer to [BCS-26, "Removal and Installation"](#).

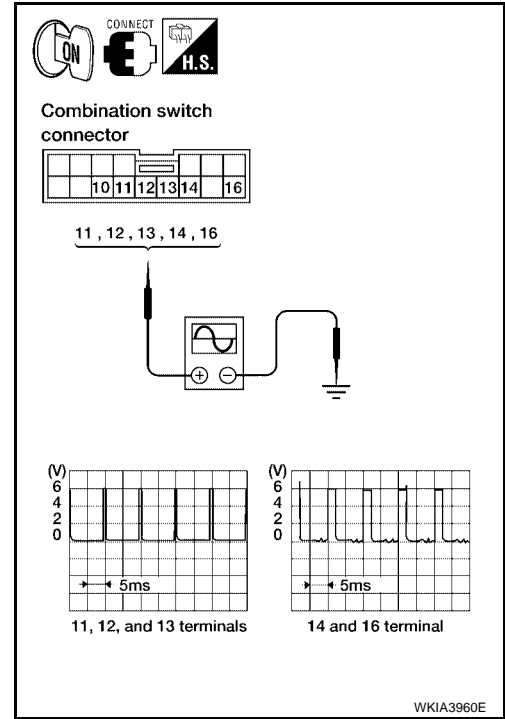

## 5. COMBINATION SWITCH INSPECTION

Referring to table below, perform combination switch inspection.

Procedure									
1	2		3	4		5	6		7
Replace lighting switch.	Confirm check results.	OK	INSPECTION END	Confirm check results.	OK	INSPECTION END	Confirm check results.	OK	INSPECTION END
		NG	Replace wiper switch.		NG	Replace switch base.		NG	Confirm symptom again.

>> Inspection End.

### Removal and Installation

EKS00BR0

Refer to [LT-76, "Removal and Installation"](#).

### Switch Circuit Inspection

EKS00BR1

Refer to [LT-81, "Combination Switch Inspection"](#).

# STOP LAMP

---

## STOP LAMP

PF2:26550

### System Description

EKS00C4B

Power is supplied at all times

- through 10A fuse [No. 20, located in fuse block (J/B)]
- to stop lamp switch terminal 1, and
- to stop lamp relay terminals 1 and 3 (with VDC).

When the brake pedal is pressed, the stop lamp switch is closed and power is supplied

- through stop lamp switch terminal 2
- to rear combination lamp LH and RH (stop) terminal 1
- to high-mounted stop lamp terminal 1
- to ABS actuator and electric unit (control unit) terminal 41, and
- to stop lamp relay terminal 5 (with VDC).

Ground is supplied

- to rear combination lamp LH and RH (stop) terminal 2
- through grounds E9, E15 (all) and E24 (VQ40DE engine only), and
- to high-mounted stop lamp terminal 2
- through grounds B117 and B132.

With power and ground supplied, the stop lamps illuminate.

# STOP LAMP

## Wiring Diagram — STOP/L —

EKS00BR3

### LT-STOP/L-01

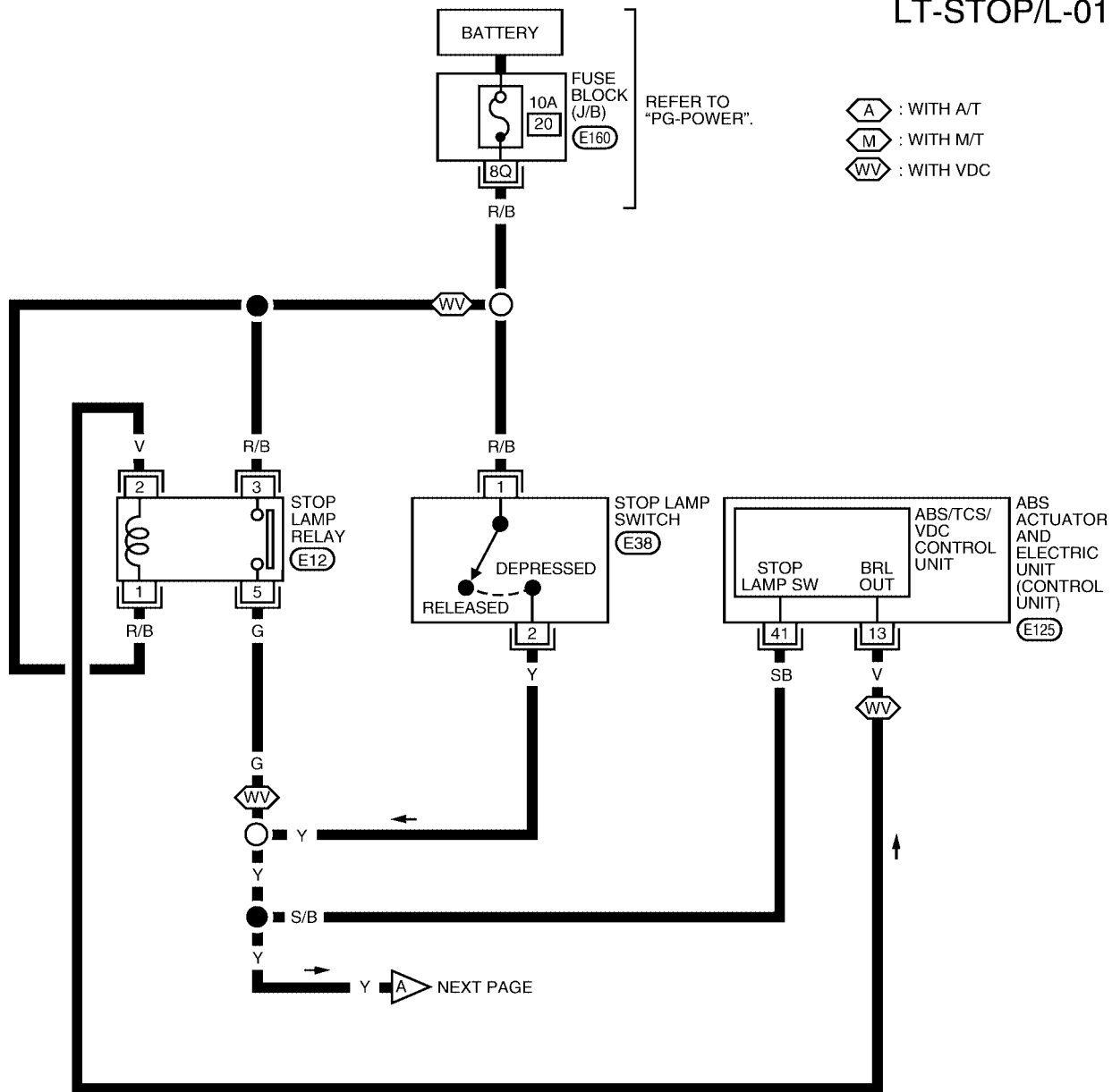

A  
B  
C  
D  
E  
F  
G  
H  
I  
J  
LT  
L  
M

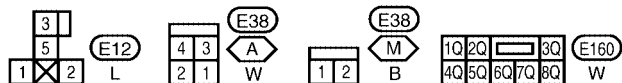

REFER TO THE FOLLOWING.  
 (E125) - ELECTRICAL UNITS

WKWA2209E

# STOP LAMP

LT-STOP/L-02

⬡ZV⬡ : WITH VQ40DE

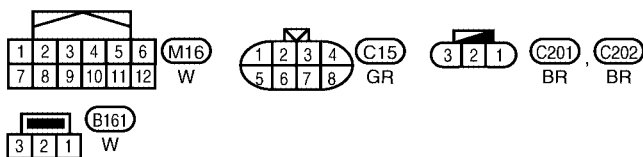
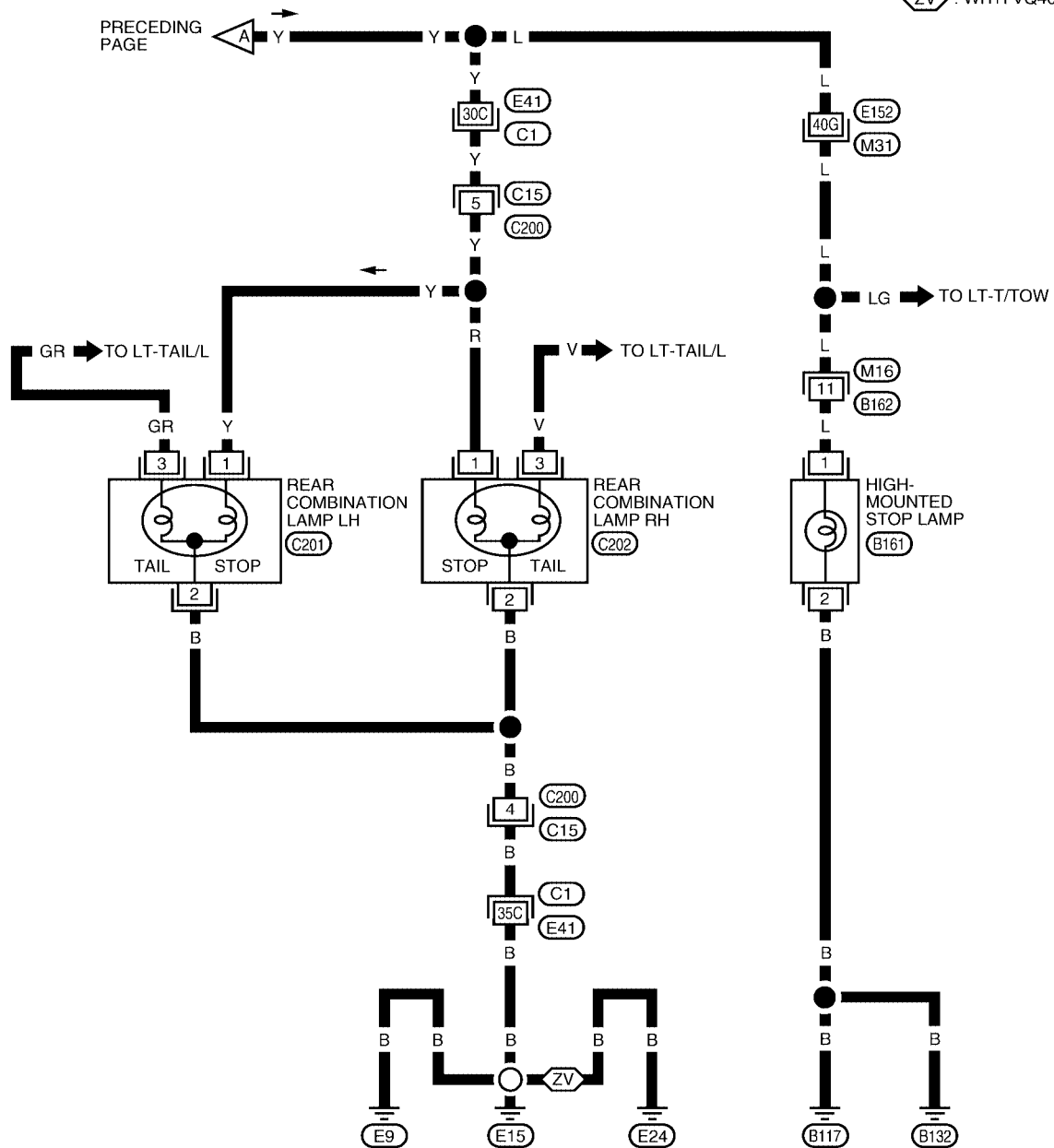

REFER TO THE FOLLOWING.  
 (M31), (C1) - SUPER  
 MULTIPLE JUNCTION (SMJ)

WKWA4361E

# STOP LAMP

## Bulb Replacement HIGH-MOUNTED STOP LAMP

EKS00BR4

### Removal

1. Remove high-mounted stop lamp. Refer to [LT-87, "HIGH-MOUNTED STOP LAMP"](#) .
2. Rotate the center bulb socket counterclockwise to release from high-mounted stop lamp assembly.
3. Pull bulb straight out from bulb socket.

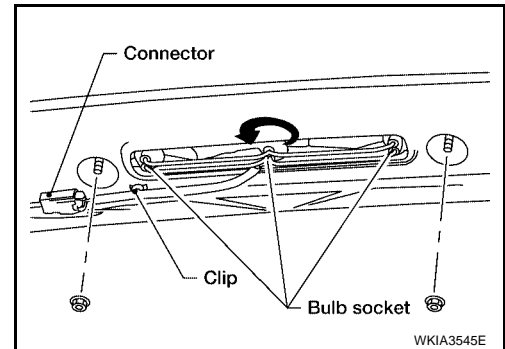

### Installation

Installation is in the reverse order of removal.

## STOP LAMP

Refer to [LT-105, "Bulb Replacement"](#) .

## Removal and Installation HIGH-MOUNTED STOP LAMP

EKS00HM6

### Removal

1. Remove plugs on headlining.
2. Remove the nuts and remove high-mounted stop lamp from outside of roof outer panel.
3. Rotate the bulb sockets counterclockwise and remove the high-mounted stop lamp assembly.

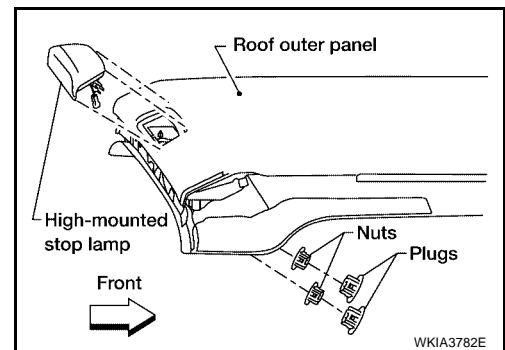

### Installation

Installation is in the reverse order of removal.

**High-mounted stop lamp nuts : 3.38 N-m (0.34 kg-m, 30 in-lb)**

## STOP LAMP

Refer to [LT-105, "Removal and Installation"](#) .

# BACK-UP LAMP

PF:26550

## BACK-UP LAMP

### Wiring Diagram — BACK/L —

EKS00BR6

## LT-BACK/L-01

- : WITH A/T
- : WITH M/T
- : WITH VQ40DE

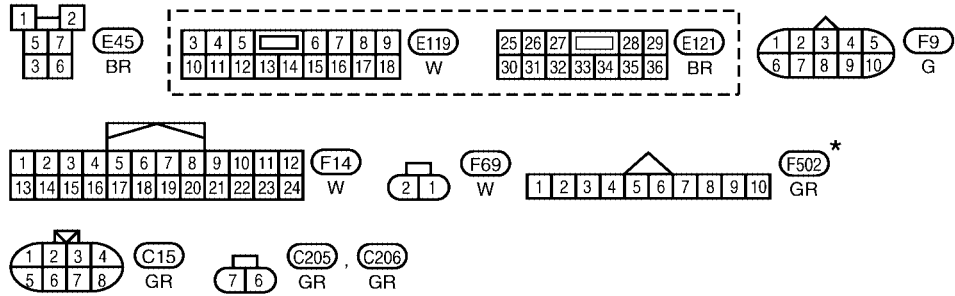
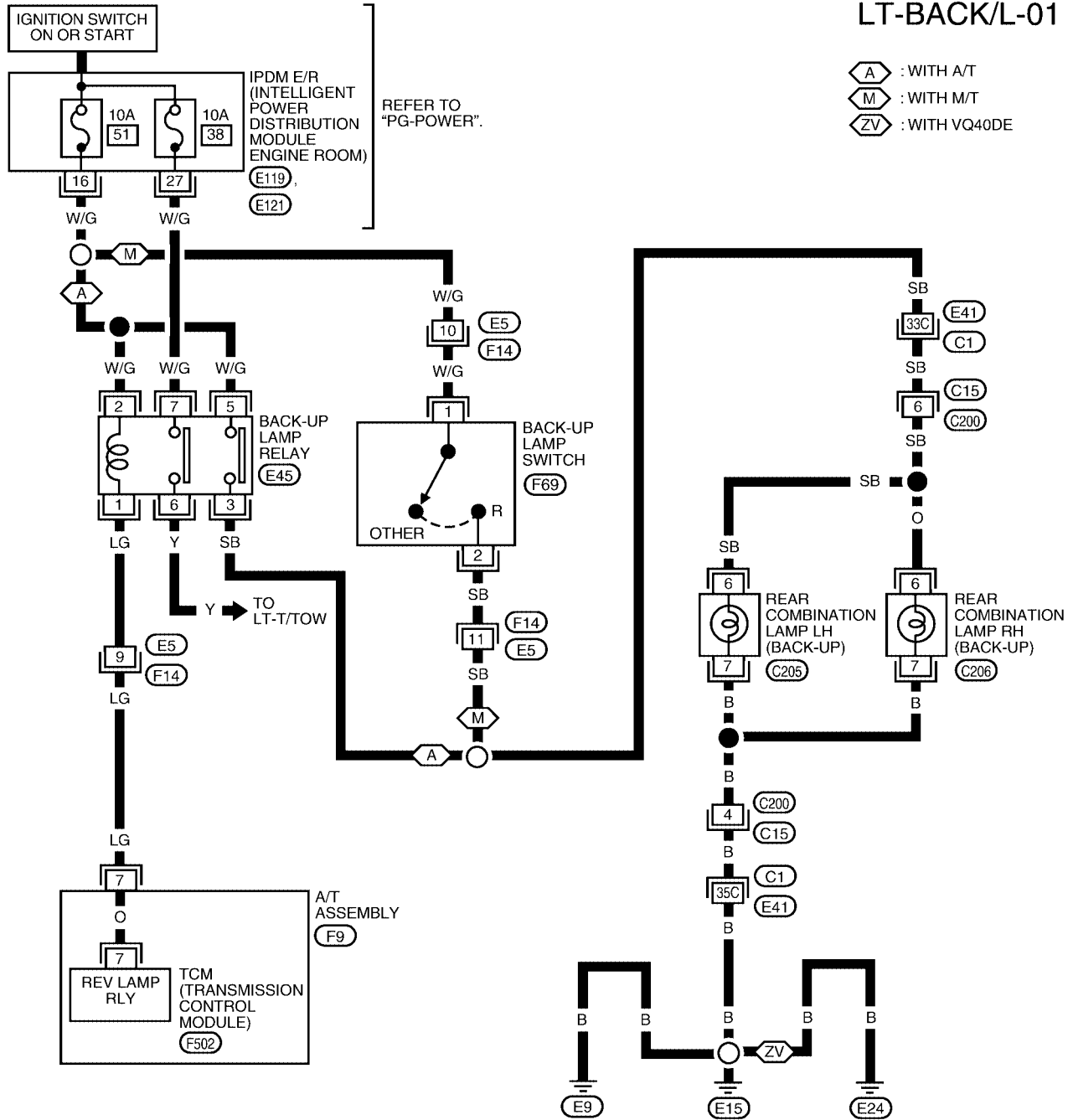

REFER TO THE FOLLOWING.  
 - SUPER MULTIPLE JUNCTION (SMJ)

\*: THIS CONNECTOR IS NOT SHOWN IN "HARNESS LAYOUT" OF PG SECTION.

WKWA4362E



# BACK-UP LAMP

---

## Bulb Replacement

EKS00BR7

Refer to [LT-105, "Bulb Replacement"](#) .

A

## Removal and Installation

EKS00BR8

Refer to [LT-105, "Removal and Installation"](#) .

B

C

D

E

F

G

H

I

J

**LT**

L

M

# PARKING, LICENSE PLATE AND TAIL LAMPS

## PARKING, LICENSE PLATE AND TAIL LAMPS

PFP:26550

### Component Parts and Harness Connector Location

EKS00HM7

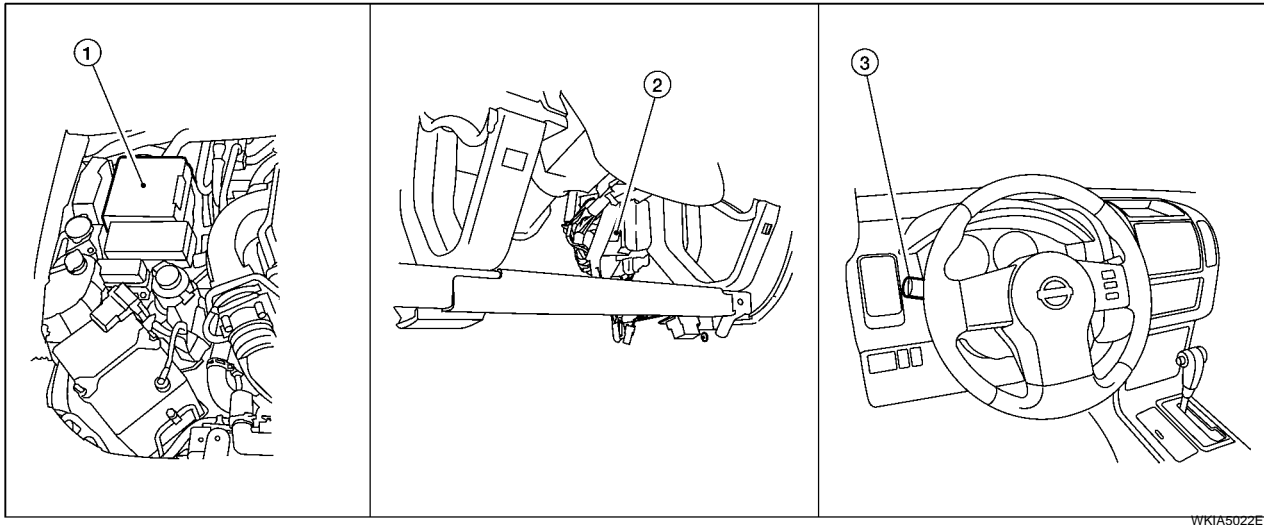

1. IPDM E/R  
E121, E122, E123, E124

2. BCM  
M18, M20  
(view with lower instrument panel LH removed)

3. Combination switch (lighting switch)  
M28

### System Description

EKS00CN6

Control of the parking, license plate, and tail lamp operation is dependent upon the position of the lighting switch (combination switch). When the lighting switch is placed in the 1ST position, the BCM (body control module) receives input signal requesting the parking, license plate, side marker and tail lamps to illuminate. This input signal is communicated to the IPDM E/R (intelligent power distribution module engine room) across the CAN communication lines. The CPU (central processing unit) of the IPDM E/R controls the tail lamp relay coil. This relay, when energized, directs power to the parking, license plate and tail lamps, which then illuminate.

Power is supplied at all times

- to tail lamp relay, located in the IPDM E/R, and
- through 20A fuse (No. 53, located in the IPDM E/R)
- to CPU of the IPDM E/R, and
- to ignition relay, located in the IPDM E/R, and
- through 50A fusible link (letter **g**, located in the fuse and fusible link box)
- to BCM terminal 70.

With the ignition switch in the ON or START position, power is supplied

- to ignition relay, located in the IPDM E/R, and
- through 10A fuse [No. 1, located in the fuse block (J/B)]
- to BCM terminal 38.

Ground is supplied

- to BCM terminal 67
- through grounds M57, M61 and M79, and
- to IPDM E/R terminals 38 and 59
- through grounds E9, E15 (all) and E24 (VQ40DE engine only).

### OPERATION BY LIGHTING SWITCH

With the lighting switch in the 1ST or 2ND position (or if the auto light system is activated), the BCM receives input signal requesting the parking, license plate, side marker and tail lamps to illuminate. This input signal is communicated to the IPDM E/R across the CAN communication lines. The CPU of the IPDM E/R controls the tail lamp relay coil, which when energized, directs power

- through 10A fuse (No. 37, located in the IPDM E/R)

## PARKING, LICENSE PLATE AND TAIL LAMPS

- through IPDM E/R terminal 57
- to license plate lamp LH and RH terminal 1
- to rear combination lamp LH and RH (tail) terminal 3, and
- through 10A fuse (No. 36, located in the IPDM E/R)
- through IPDM E/R terminal 28
- to front combination lamp LH (side marker) terminal 7
- to front combination lamp LH (parking) terminal 4, and
- through IPDM E/R terminal 49
- to front combination lamp RH (side marker) terminal 7
- to front combination lamp RH (parking) terminal 4.

Ground is supplied

- to front combination lamp LH and RH (side marker) terminal 8
- to front combination lamp LH and RH (parking) terminal 5
- to license plate lamp LH and RH terminal 2
- to rear combination lamp LH and RH (tail) terminal 2
- through grounds E9, E15 (all) and E24 (VQ40DE engine only).

With power and ground supplied, the parking, side marker, license plate and tail lamps illuminate.

### COMBINATION SWITCH READING FUNCTION

Refer to [BCS-3, "COMBINATION SWITCH READING FUNCTION"](#) .

### EXTERIOR LAMP BATTERY SAVER CONTROL

When the combination switch (lighting switch) is in the 1ST (or 2ND) position, and the ignition switch is turned from ON or ACC to OFF, the battery saver control feature is activated.

Under this condition, the parking, side marker, license and tail lamps remain illuminated for 5 minutes, then the parking, side marker, license plate and tail lamps are turned off.

Exterior lamp battery saver control mode can be changed by the function setting of CONSULT-II.

### CAN Communication System Description

Refer to [LAN-22, "CAN COMMUNICATION"](#) .

EKS00BRB

LT

L

M

# PARKING, LICENSE PLATE AND TAIL LAMPS

## Schematic

EKS00BRC

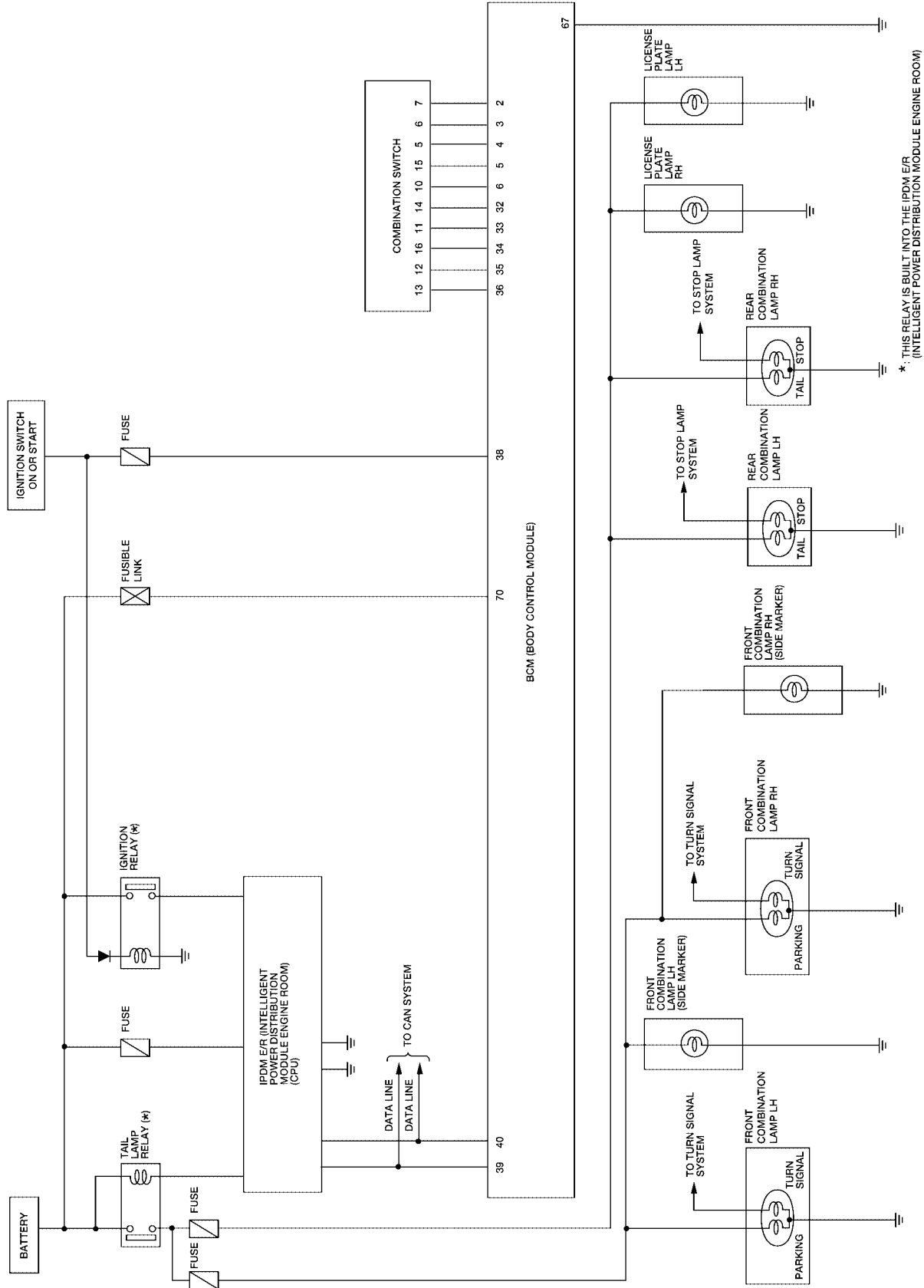

WKWA4363E

# PARKING, LICENSE PLATE AND TAIL LAMPS

## Wiring Diagram — TAIL/L —

EKS00BRD

### LT-TAIL/L-01

— : DATA LINE

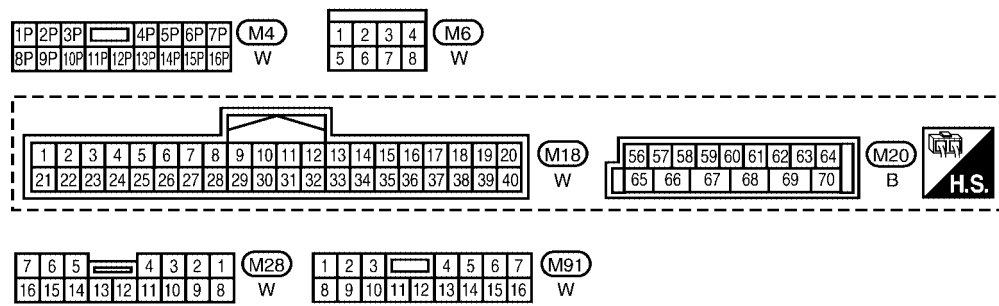
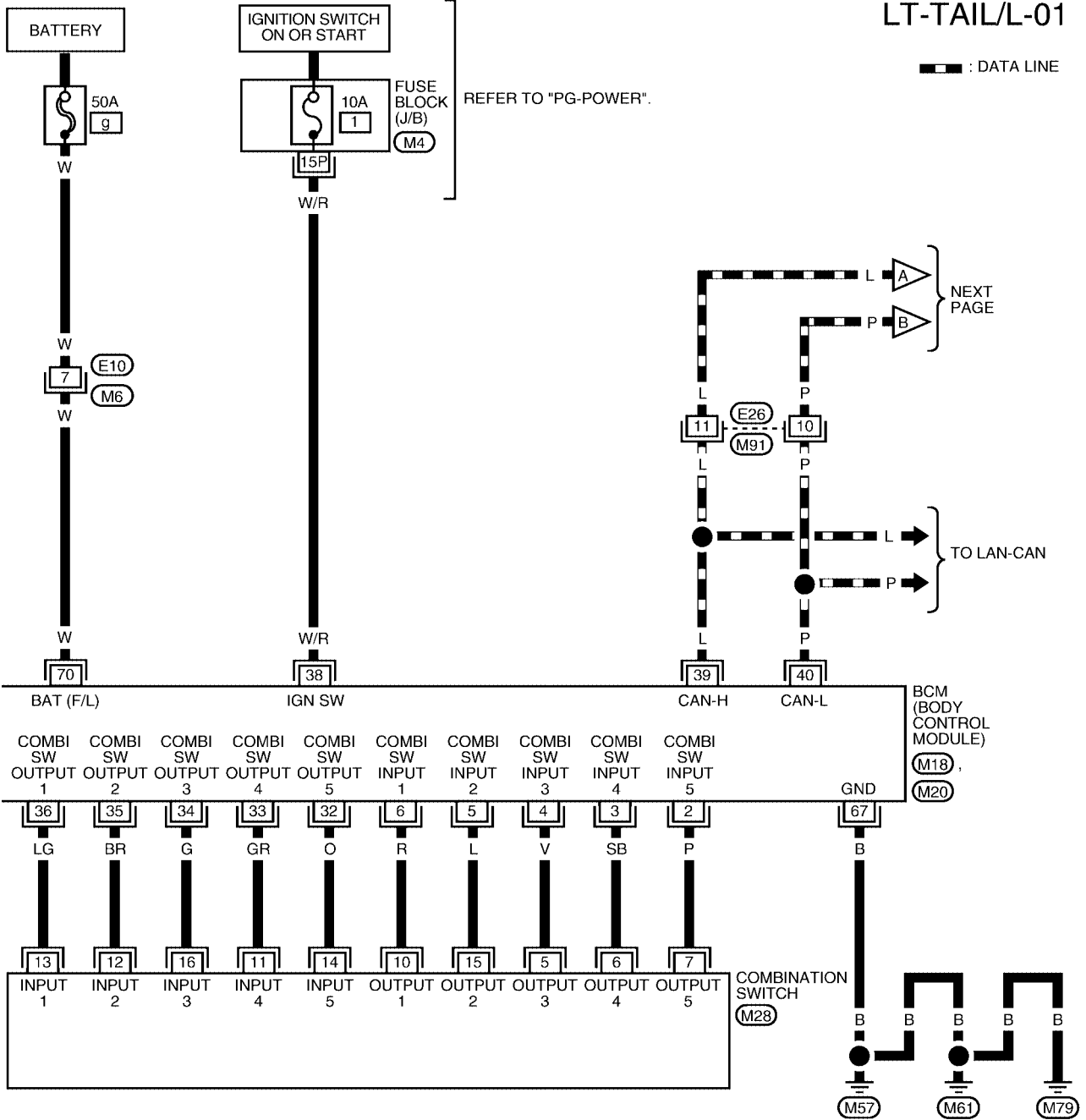

REFER TO THE FOLLOWING.  
 (M31) - SUPER MULTIPLE JUNCTION (SMJ)

# PARKING, LICENSE PLATE AND TAIL LAMPS

## LT-TAIL/L-02

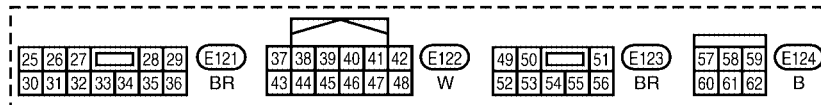
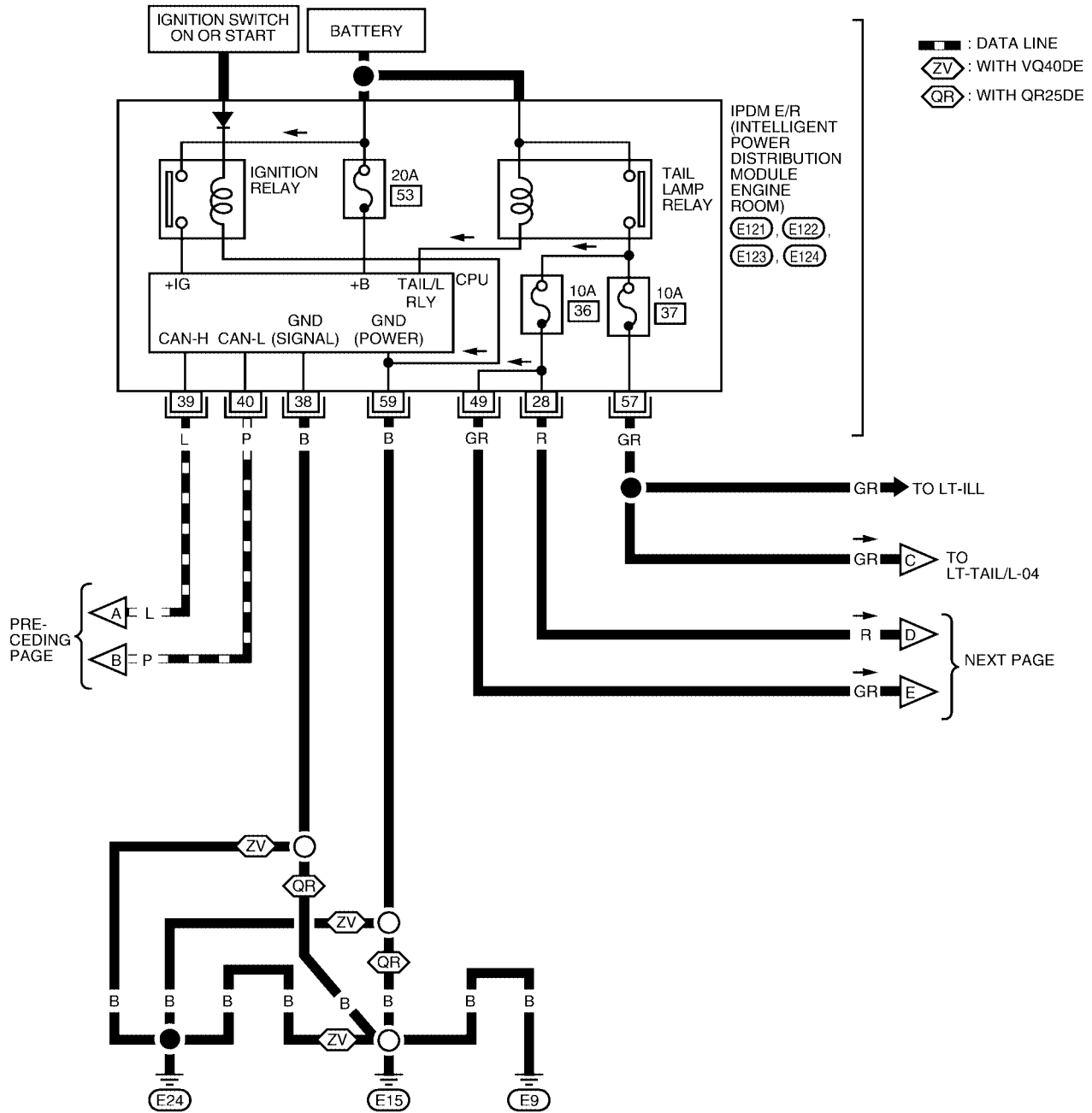

WKWA2220E

# PARKING, LICENSE PLATE AND TAIL LAMPS

LT-TAIL/L-03

 : WITH VQ40DE

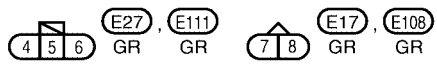
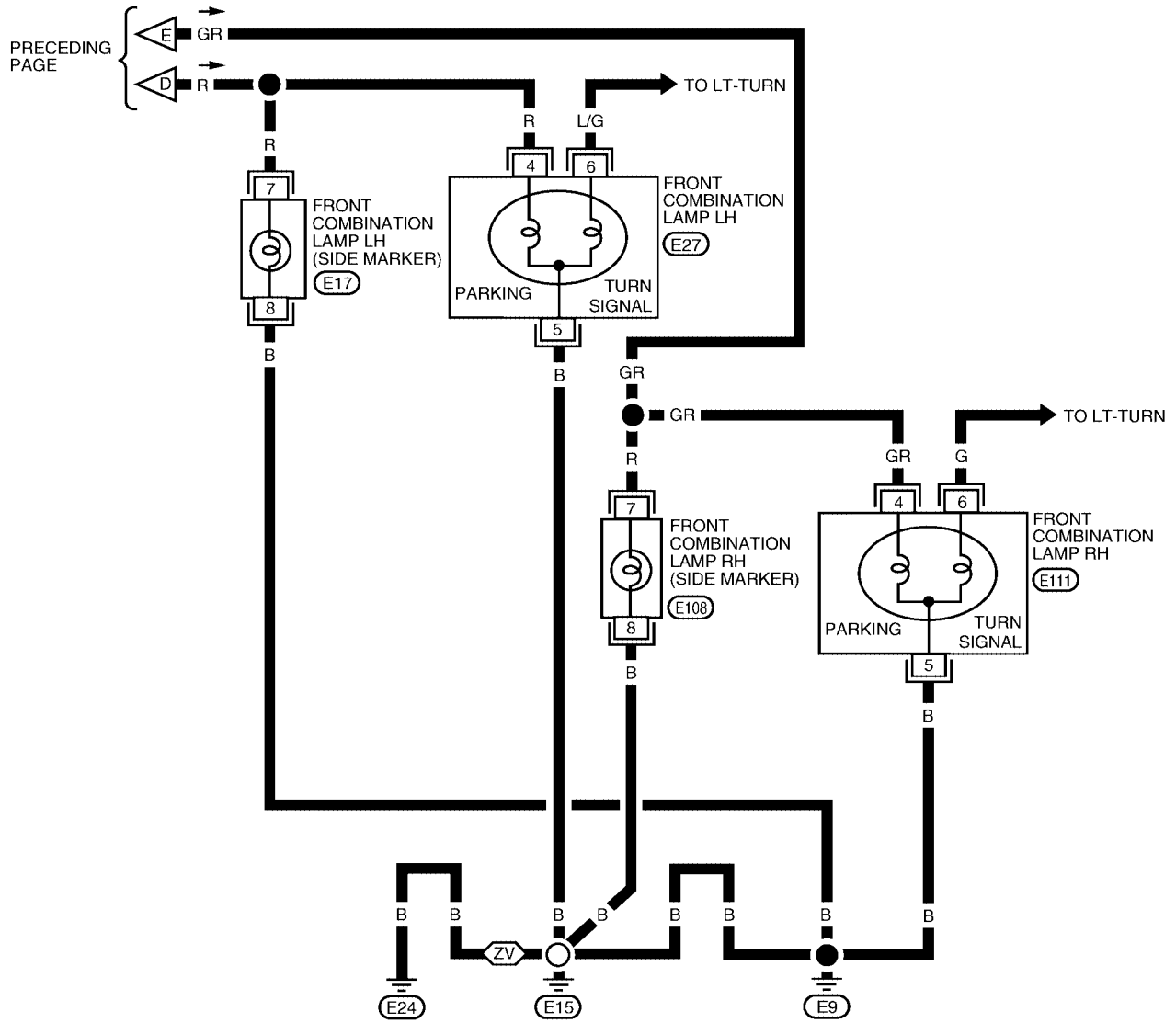

LT

WKWA2221E

# PARKING, LICENSE PLATE AND TAIL LAMPS

LT-TAIL/L-04

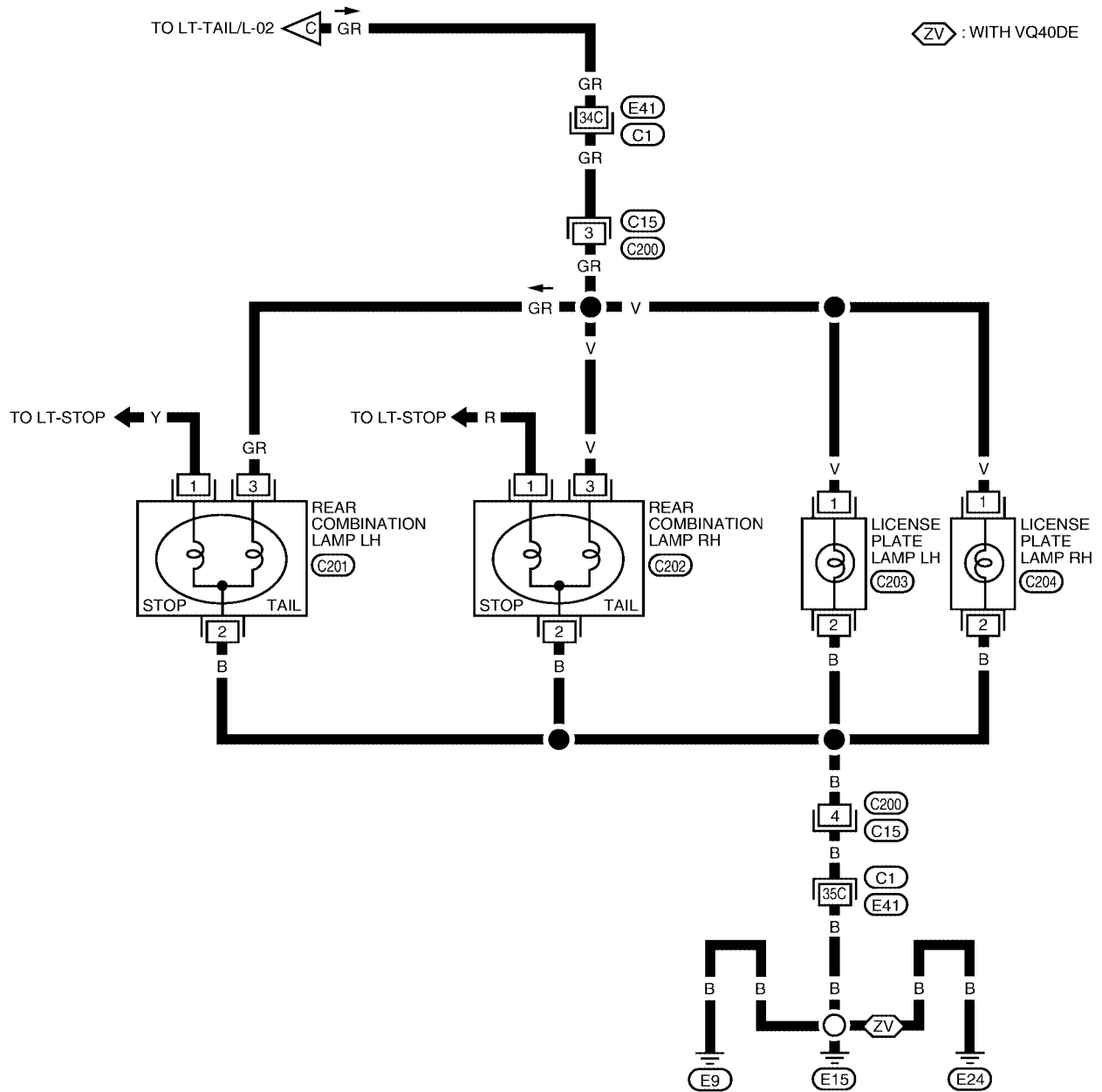

REFER TO THE FOLLOWING.  
 (C1) - SUPER MULTIPLE JUNCTION (SMJ)

WKWA4365E



# PARKING, LICENSE PLATE AND TAIL LAMPS

## Terminals and Reference Values for BCM

EKS00CN7

Refer to [BCS-12, "Terminals and Reference Values for BCM"](#) .

## Terminals and Reference Values for IPDM E/R

EKS00CN8

Refer to [PG-29, "Terminals and Reference Values for IPDM E/R"](#) .

## How to Proceed With Trouble Diagnosis

EKS00CN9

1. Confirm the symptom or customer complaint.
2. Understand operation description and function description. Refer to [LT-90, "System Description"](#) .
3. Carry out the Preliminary Check. Refer to [LT-97, "Preliminary Check"](#) .
4. Check symptom and repair or replace the cause of malfunction.
5. Do the parking, license and tail lamps operate normally? If YES: GO TO 6. If NO: GO TO 4.
6. Inspection End.

## Preliminary Check

EKS00CNA

### CHECK POWER SUPPLY AND GROUND CIRCUIT

Refer to [BCS-16, "BCM Power Supply and Ground Circuit Check"](#) and [PG-31, "IPDM E/R Power/Ground Circuit Inspection"](#) .

## CONSULT-II Functions

EKS00CNB

Refer to [LT-12, "CONSULT-II Function \(BCM\)"](#) .  
Refer to [LT-15, "CONSULT-II Function \(IPDM E/R\)"](#) .

## Parking, Side Marker, License Plate and/or Tail Lamps Do Not Illuminate

EKS00CNC

### 1. CHECK COMBINATION SWITCH INPUT SIGNAL

Ⓜ With CONSULT-II

Select "BCM" on CONSULT-II. With "HEAD LAMP" data monitor, make sure "LIGHT SW 1ST" turns ON-OFF linked with operation of lighting switch.

**When lighting switch is in 1ST position : LIGHT SW 1ST ON**

ⓧ Without CONSULT-II

Refer to [LT-81, "Combination Switch Inspection"](#) .

OK or NG

OK >> GO TO 2.

NG >> Check lighting switch. Refer to [LT-81, "Combination Switch Inspection"](#) .

DATA MONITOR	
MONITOR	
LIGHT SW 1ST	ON

SKIA6956E

# PARKING, LICENSE PLATE AND TAIL LAMPS

## 2. ACTIVE TEST

Ⓟ With CONSULT-II

1. Select "IPDM E/R" on CONSULT-II, and select "ACTIVE TEST" on "SELECT DIAG MODE" screen.
2. Select "EXTERNAL LAMPS" on "SELECT TEST ITEM" screen.
3. Touch "TAIL" on "ACTIVE TEST" screen.
4. Make sure front parking, front side marker, license plate and tail lamp operation.

**Front parking, front side marker, license plate and tail lamps should operate**

ACTIVE TEST			
EXTERNAL LAMPS		OFF	
		TAIL	
LO		HI	
FOG			
MODE	BACK	LIGHT	COPY

WKIA1438E

ⓧ Without CONSULT-II

1. Start auto active test. Refer to [PG-24, "Auto Active Test"](#) .
2. Make sure front parking, front side marker, license plate and tail lamp operation.

**Front parking, front side marker, license plate and tail lamps should operate**

OK or NG

- OK >> GO TO 3.  
 NG >> GO TO 4.

## 3. CHECK IPDM E/R

1. Select "IPDM E/R" on CONSULT-II, and select "DATA MONITOR" on "SELECT DIAG MODE" screen.
2. Make sure "TAIL&CLR REQ" turns ON when lighting switch is in 1ST position.

**When lighting switch is in 1ST position : TAIL&CLR REQ ON**

OK or NG

- OK >> Replace IPDM E/R. Refer to [PG-33, "Removal and Installation of IPDM E/R"](#) .  
 NG >> Replace BCM. Refer to [BCS-26, "Removal and Installation"](#) .

DATA MONITOR			
MONITOR			
TAIL&CLR REQ		ON	
		RECORD	
MODE	BACK	LIGHT	COPY

SKIA5958E

# PARKING, LICENSE PLATE AND TAIL LAMPS

## 4. CHECK INPUT SIGNAL

Ⓜ With CONSULT-II

1. Turn ignition switch OFF.
2. Disconnect front combination lamp (side marker), front combination lamp (parking), license plate lamp and rear combination lamp (tail) connectors.
3. Turn ignition switch ON.
4. Select "IPDM E/R" on CONSULT-II, and select "ACTIVE TEST" on "SELECT DIAG MODE" screen.
5. Select "TAIL LAMP" on "SELECT TEST ITEM" screen.
6. Touch "ON" on "ACTIVE TEST" screen.
7. When tail lamp is operating, check voltage between front combination lamp (side marker), front combination lamp (parking), license plate lamp, rear combination lamp (tail) harness connector and ground.

ⓧ Without CONSULT-II

1. Turn ignition switch OFF.
2. Start auto active test. Refer to [PG-24, "Auto Active Test"](#).
3. When tail lamp is operating, check voltage between front combination lamp (side marker), front combination lamp (parking), license plate lamp, rear combination lamp (tail) harness connector and ground.

Front combination lamp (side marker)		Terminal	(-)	Voltage
(+)				
Connector		7	Ground	Battery voltage
LH	E17			
RH	E108			

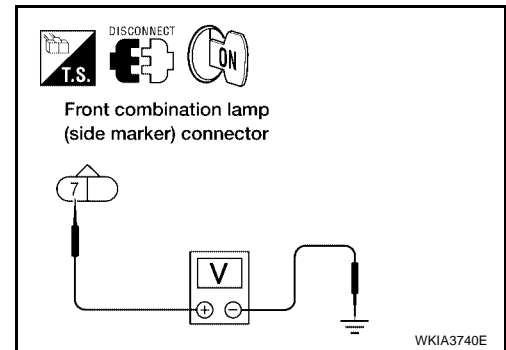

Front combination lamp (parking)		Terminal	(-)	Voltage
(+)				
Connector		4	Ground	Battery voltage
LH	E27			
RH	E111			

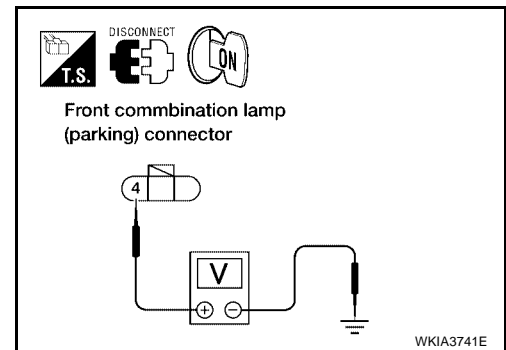

License plate lamp		Terminal	(-)	Voltage
(+)				
Connector		1	Ground	Battery voltage
LH	C203			
RH	C204			

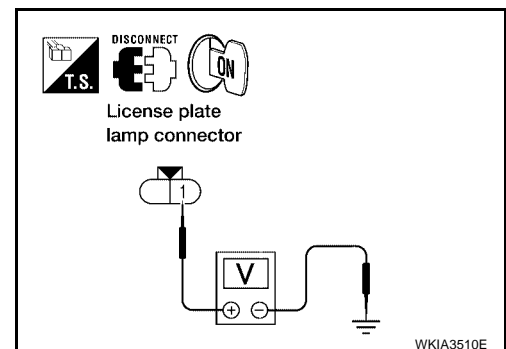

# PARKING, LICENSE PLATE AND TAIL LAMPS

Rear combination lamp (tail)		(-)	Voltage
(+)			
Connector	Terminal	Ground	Battery voltage
LH	C201		
RH	C202		

## OK or NG

OK >> GO TO 6.  
 NG >> GO TO 5.

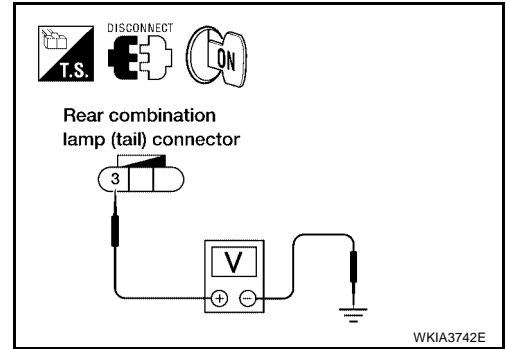

# PARKING, LICENSE PLATE AND TAIL LAMPS

## 5. CHECK PARKING, SIDE MARKER, LICENSE PLATE AND TAIL LAMP CIRCUIT

1. Turn ignition switch OFF.
2. Disconnect IPDM E/R connector.
3. Check continuity between IPDM E/R harness connector and front combination lamp (side marker) harness connector.

IPDM E/R		Front combination lamp (side marker)		Continuity
Connector	Terminal	Connector	Terminal	
E121	28	LH	E17	Yes
E123	49	RH	E108	

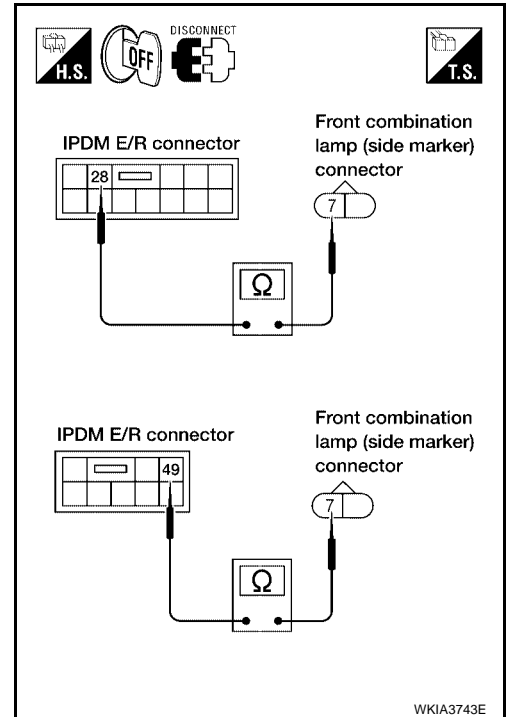

4. Check continuity between IPDM E/R harness connector and front combination lamp (parking) harness connector.

IPDM E/R		Front combination lamp (parking)		Continuity
Connector	Terminal	Connector	Terminal	
E121	28	LH	E27	Yes
E123	49	RH	E111	

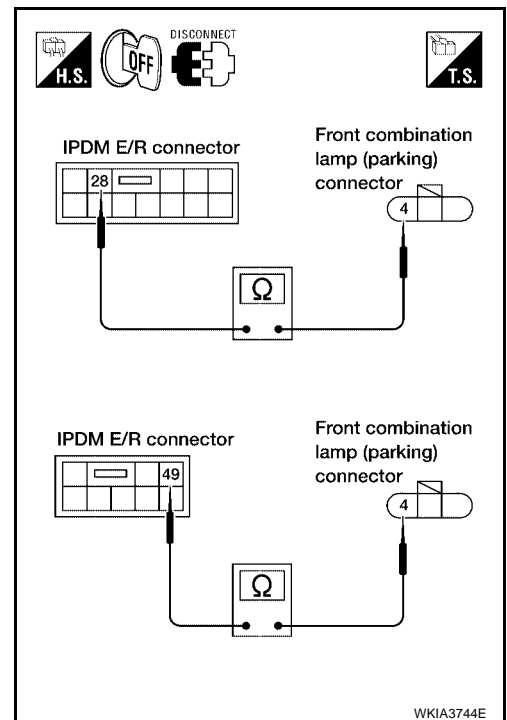

A  
B  
C  
D  
E  
F  
G  
H  
I  
J  
LT  
L  
M

## PARKING, LICENSE PLATE AND TAIL LAMPS

5. Check continuity between IPDM E/R harness connector and license plate lamp harness connector.

IPDM E/R		License plate lamp		Continuity	
Connector	Terminal	Connector	Terminal		
E124	57	LH	C203	1	Yes
		RH	C204		

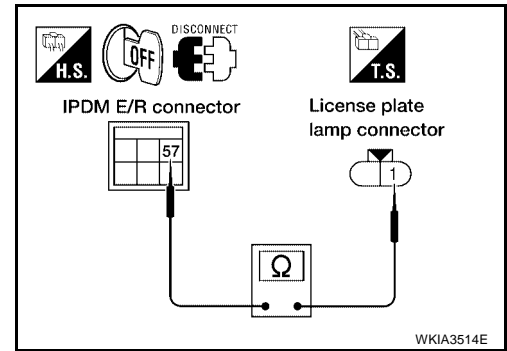

6. Check continuity between IPDM E/R harness connector and rear combination lamp (tail) harness connector.

IPDM E/R		Rear combination lamp (tail)		Continuity	
Connector	Terminal	Connector	Terminal		
E124	57	LH	C201	3	Yes
		RH	C202		

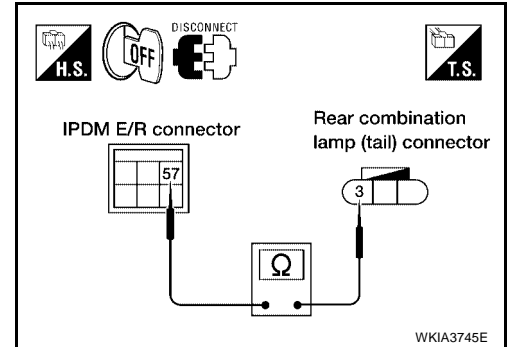

OK or NG

- OK >> Replace IPDM E/R. Refer to [PG-33, "Removal and Installation of IPDM E/R"](#) .
- NG >> Repair harness or connector.

# PARKING, LICENSE PLATE AND TAIL LAMPS

## 6. CHECK GROUND

1. Check continuity between front combination lamp (side marker) harness connector and ground.

Front combination lamp (side marker)		Terminal	Ground	Continuity
Connector				
LH	E17	8	Ground	Yes
RH	E108			

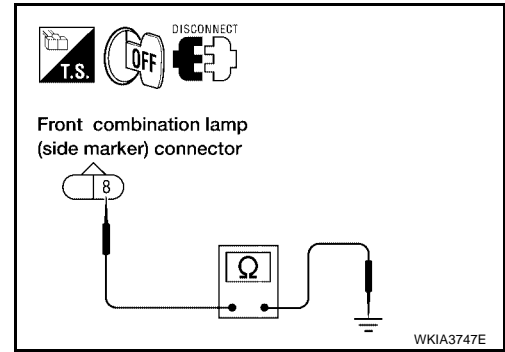

2. Check continuity between front combination lamp (parking) harness connector and ground.

Front combination lamp (parking)		Terminal	Ground	Continuity
Connector				
LH	E27	5	Ground	Yes
RH	E111			

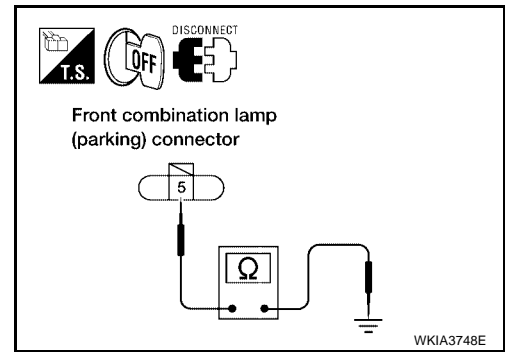

3. Check continuity between license plate lamp harness connector and ground.

License plate lamp		Terminal	Ground	Continuity
Connector				
LH	C203	2	Ground	Yes
RH	C204			

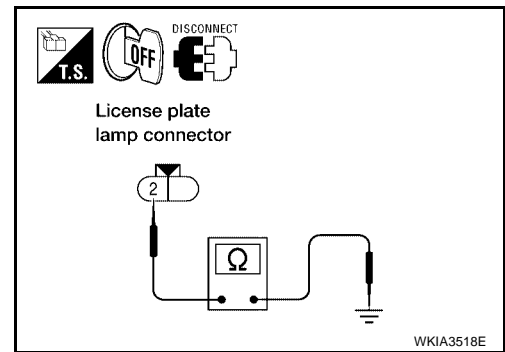

4. Check continuity between rear combination lamp (tail) harness connector and ground.

Rear combination lamp (tail)		Terminal	Ground	Continuity
Connector				
LH	C201	32	Ground	Yes
RH	C202			

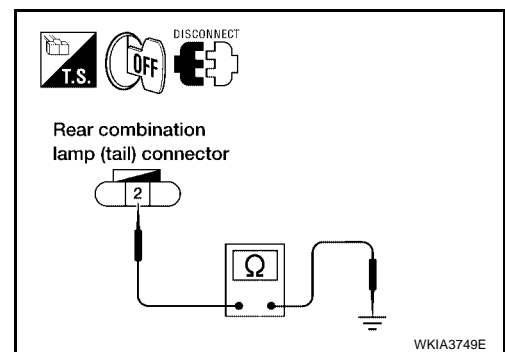

### OK or NG

- OK >> Check bulbs.  
 NG >> Repair harness or connector.

A  
B  
C  
D  
E  
F  
G  
H  
I  
J  
LT  
L  
M

# PARKING, LICENSE PLATE AND TAIL LAMPS

---

## Parking, Side Marker, License Plate and Tail Lamps Do Not Turn OFF (After Approx. 10 Minutes)

EKS00CND

### 1. CHECK IPDM E/R

---

1. Turn ignition switch ON. Turn the combination switch (lighting switch) to the OFF position. Turn ignition switch OFF.
2. Verify that the front parking, front side marker, license plate, and tail lamps turn on and off after approximately 10 minutes.

#### OK or NG

- OK >> Ignition relay malfunction. Refer to [PG-19, "Function of Detecting Ignition Relay Malfunction"](#) .  
NG >> Inspection End.

## Bulb Replacement FRONT PARKING LAMP

EKS00BRL

Refer to [LT-27, "FRONT TURN SIGNAL/PARKING LAMP"](#) .

### LICENSE PLATE LAMP

#### Removal

1. Turn bulb socket counterclockwise to unlock bulb socket.
2. Pull bulb to remove from bulb socket.

#### Installation

Installation is in the reverse order of removal.

### TAIL LAMP

Refer to [LT-105, "REMOVAL"](#)

## Removal and Installation FRONT PARKING LAMP

EKS00HM8

Refer to [LT-27, "Removal and Installation"](#) .

### LICENSE PLATE LAMP

#### Removal

1. Disconnect license plate lamp harness.
2. Depress tab to remove license plate lamp from rear bumper.

#### Installation

Installation is in the reverse order of removal.

### TAIL LAMP

Refer to [LT-105, "Removal and Installation"](#) .



# REAR COMBINATION LAMP

PFP:26554

## REAR COMBINATION LAMP

### Bulb Replacement REMOVAL

1. Remove rear combination lamp. Refer to [LT-105, "Removal and Installation"](#).
2. Turn bulb counterclockwise to remove bulb socket.
3. Pull bulb straight out away from socket to release.

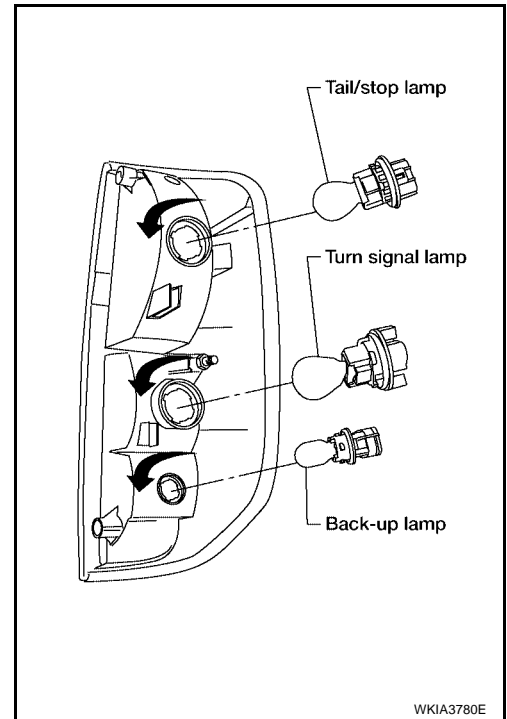

### INSTALLATION

Installation is in the reverse order of removal.

### Removal and Installation REMOVAL

1. Open tailgate and remove rear combination lamp bolts.
2. Pull combination lamp housing rearward to release locating snap.
3. Rotate each bulb socket counterclockwise to unlock it from lamp housing and remove from vehicle.

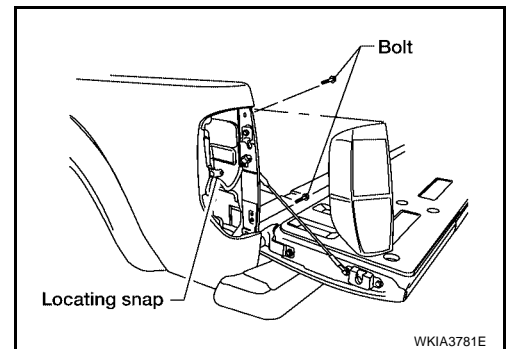

### INSTALLATION

Installation is in the reverse order of removal.

#### NOTE:

During installation, align locating snap on body prior to installing bolts.

**Rear combination lamp bolts : 2.4 Nm (0.24 kg-m, 21 in-lb)**

A  
B  
C  
D  
E  
F  
G  
H  
I  
J  
LT  
L  
M

# TRAILER TOW

PFP:93020

## TRAILER TOW

### Component Parts and Harness Connector Location

EKS00BRP

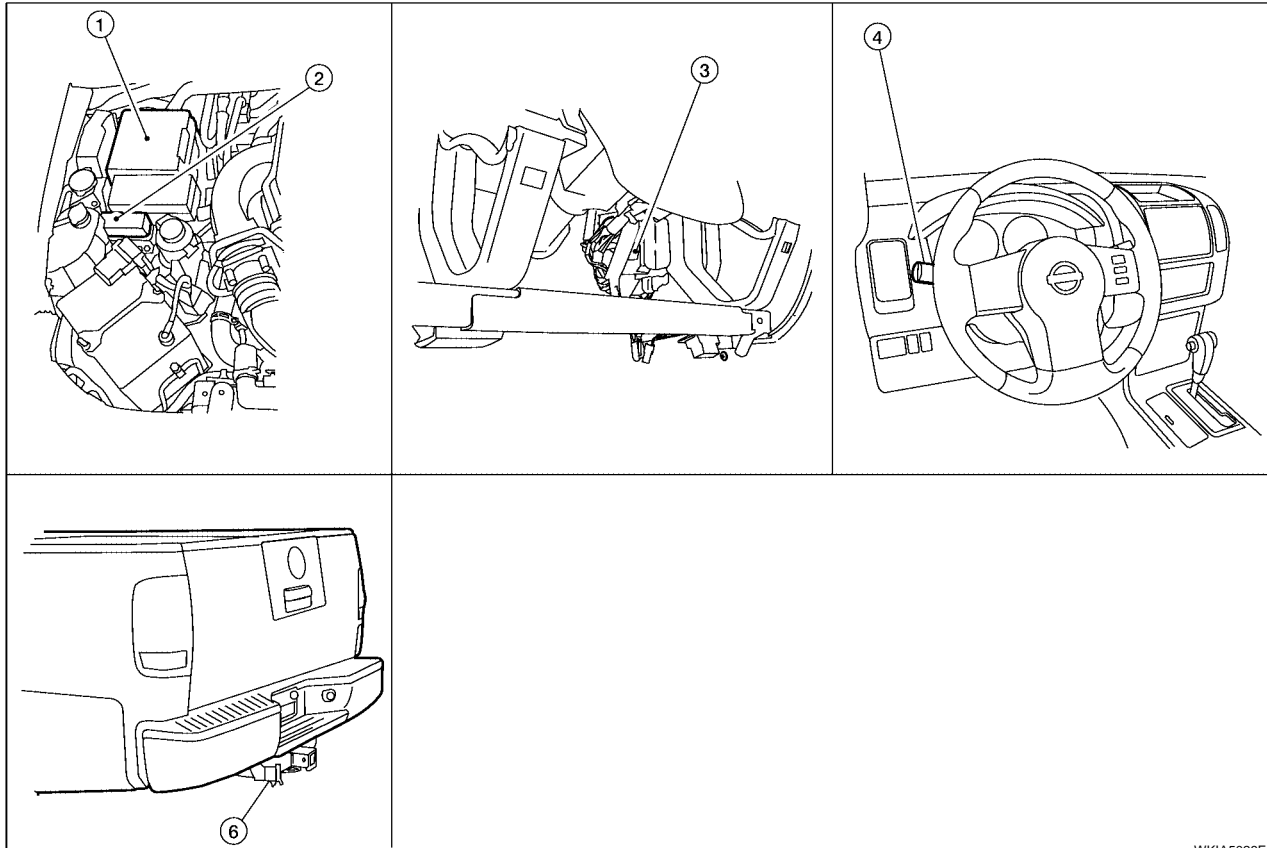

WKIA5026E

- |  |                                     |  |
|--|-------------------------------------|--|
| 1. IPDM E/R<br>E121, E122, E124                | 2. Trailer tow relays<br>E140, E148 | 3. BCM<br>M18, M19, M20<br>(view with lower instrument panel LH removed) |
| 4. Combination switch (lighting switch)<br>M28 | 5. Trailer<br>C126                  |  |

### System Description

EKS00HM9

Power is supplied at all times

- to ignition relay, located in the IPDM E/R (intelligent power distribution module engine room), and
- to tail lamp relay, located in the IPDM E/R, and
- through 50A fusible link (letter **g** , located in the fuse and fusible link box)
- to BCM (body control module) terminal 70, and
- to 15A fuse (No. 60, located in the fuse and relay box),
- to trailer turn relay RH and LH terminal 5, and
- through 20A fuse (No. 53, located in the IPDM E/R)
- to CPU of the IPDM E/R, and
- through 10A fuse (No. 32, located in the IPDM E/R)
- to IPDM E/R terminal 61
- to trailer tow relay 1 terminal 3, and
- through 30A fusible link (letter **m** , located in the fuse and fusible link box)
- to trailer tow relay 2 terminals 3 and 6, and
- through 30A fusible link (letter **h** , located in the fuse and fusible link box)
- to electric brake (pre-wiring) terminal 5.

With the ignition switch in the ON or START position, power is supplied

# TRAILER TOW

- to ignition relay, located in the IPDM E/R, and
- through 10A fuse [No. 1, located in the fuse block (J/B)]
- to BCM terminal 38, and
- through 10A fuse (No. 38, located in the IPDM E/R)
- to IPDM E/R terminal 27,
- to trailer tow relay 2 terminal 1, and
- to back-up lamp relay terminal 3 (with M/T).

Ground is supplied

- to BCM terminal 67 and
- to electric brake (pre-wiring) terminal 1
- through grounds M57, M61 and M79, and
- to IPDM E/R terminals 38 and 59
- to trailer tow relay 1 terminal 2
- to trailer tow relay 2 terminal 2
- to trailer connector terminal 2
- to trailer turn relay RH and LH terminal 2, and
- to back-up lamps relay terminal 1 (with M/T)
- through grounds E9, E15 and E24.

## TRAILER TAIL LAMP OPERATION

The trailer tail lamps are controlled by the trailer tow relay 1.

With the lighting switch in the parking and tail lamp ON (1ST) position, AUTO position (and the auto light system is activated) or headlamp ON (2ND) position, power is supplied from the tail lamp relay

- through 10A fuse (No. 37, located in the IPDM E/R)
- through IPDM E/R terminal 29
- to trailer tow relay 1 terminal 1.

When energized, power is supplied

- through trailer tow relay 1 terminal 5
- to trailer connector terminal 4.

## TRAILER STOP, TURN SIGNAL AND HAZARD LAMP OPERATION

The trailer stop, turn signal and hazard lamps are controlled by the BCM. If either turn signal or the hazard lamps are turned on, the BCM supplies voltage to the trailer turn relay RH or LH to make them flash. If the BCM receives stop lamp switch signal, the BCM supplies voltage to the trailer turn relay RH and LH to make them illuminate.

Left stop, turn signal and hazard lamp output is supplied

- through BCM terminal 52
- to trailer turn relay LH terminal 1

When energized, trailer turn relay LH supplies power to the left stop, turn signal, and hazard lamp

- through trailer turn relay LH terminal 3
- to trailer connector terminal 3.

Right stop, turn signal and hazard lamp output is supplied

- through BCM terminal 51
- to trailer turn relay RH terminal 1

When energized, trailer turn relay RH supplies power to the right stop, turn signal, and hazard lamp

- through trailer turn relay RH terminal 3
- to trailer connector terminal 6.

## TRAILER POWER SUPPLY OPERATION

The trailer power supply is controlled by trailer tow relay 2.

When the ignition switch is in the ON or START position, power is supplied

- through 10A fuse (No. 38, located in the IPDM E/R)

A

B

C

D

E

F

G

H

I

J

LT

L

M

## TRAILER TOW

---

- through IPDM E/R terminal 27
- to trailer tow relay 2 terminal 1.

When energized, trailer tow relay 2 power is supplied

- through trailer tow relay 2 terminals 5 and 7
- to trailer connector terminal 5.

### **TRAILER BACK-UP LAMPS OPERATION**

The trailer back-up lamps are controlled by back-up lamp relay.

When the ignition switch is in the ON or START position, power is supplied

- through 10A fuse (No. 38, located in the IPDM E/R)
- through IPDM E/R terminal 27
- to back-up lamp relay terminal 3 (with M/T) or 7 (with A/T).

When energized, back-up lamp relay power is supplied

- through back-up lamp relay terminal 5 (with M/T) or 6 (with A/T)
- to trailer connector terminal 7.

# TRAILER TOW

## Schematic

EKS00BRR

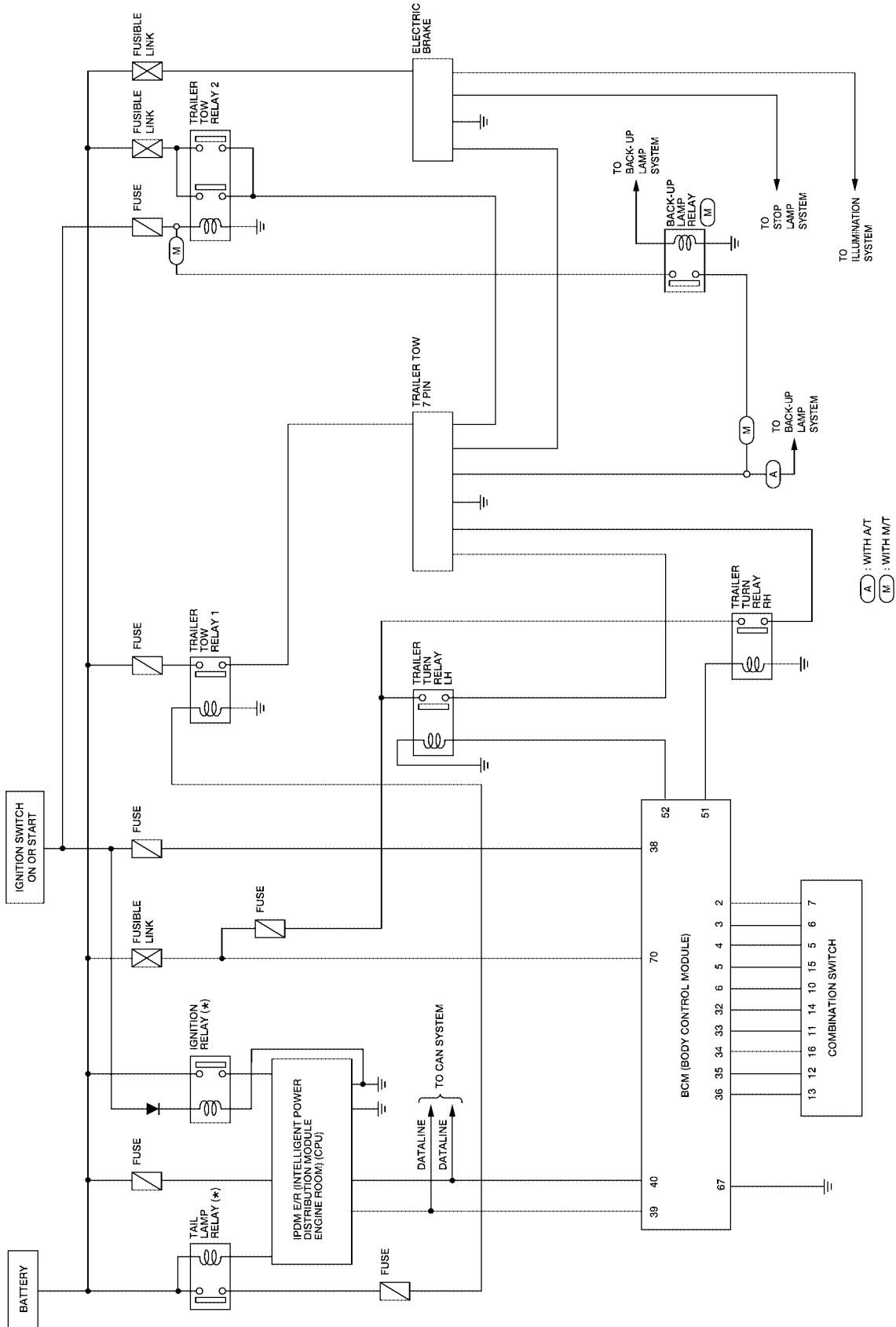

A  
B  
C  
D  
E  
F  
G  
H  
I  
J  
LT  
L  
M

# TRAILER TOW

## Wiring Diagram — T/TOW —

EKS00BRS

### LT-T/TOW-01

— : DATA LINE

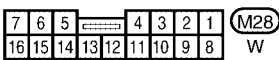
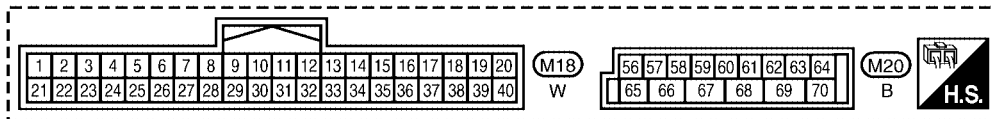
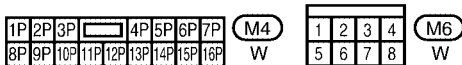
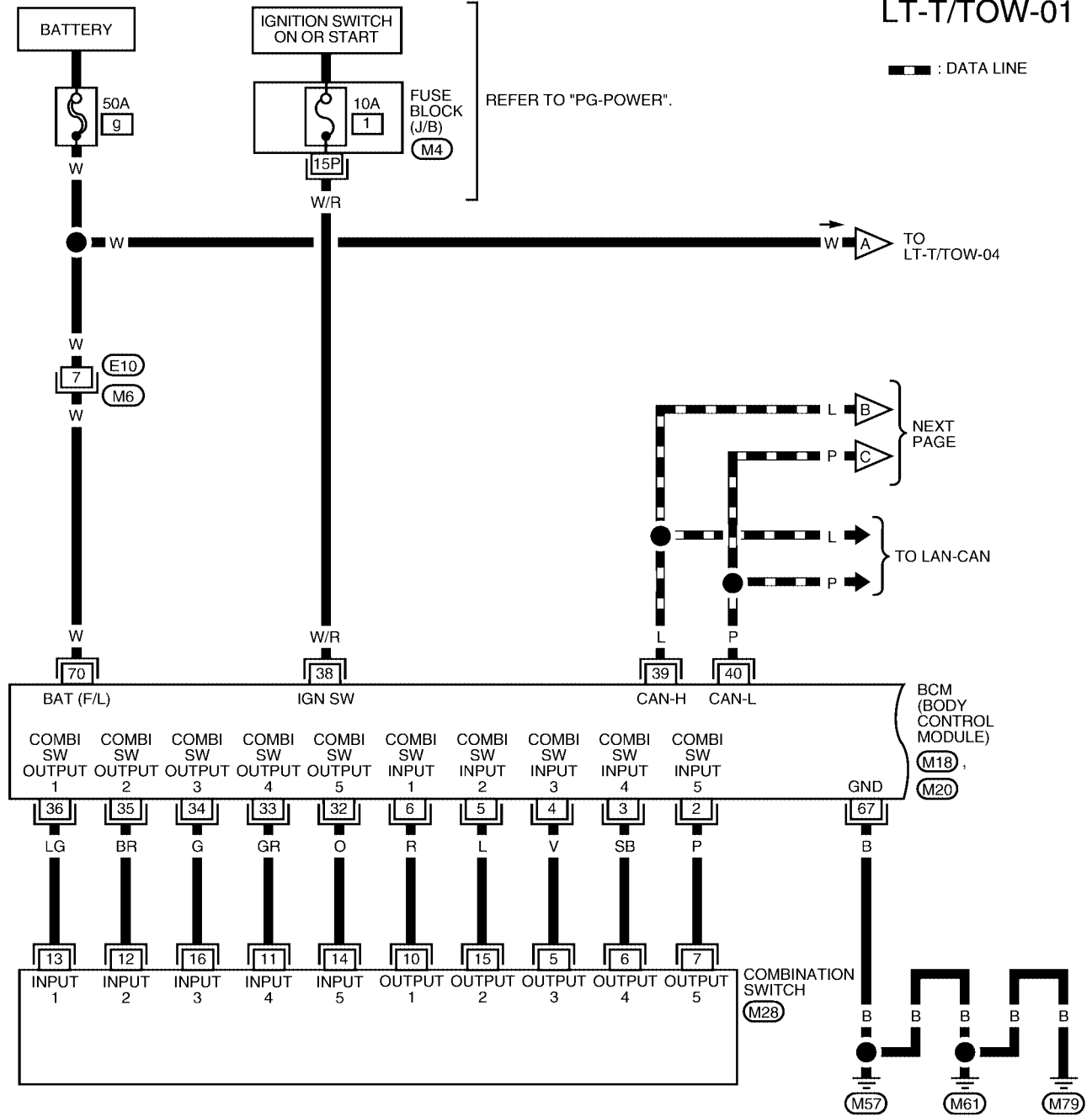

WKWA4367E



# TRAILER TOW

LT-T/TOW-03

(M) : WITH M/T

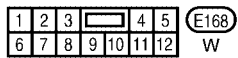
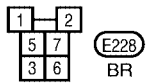
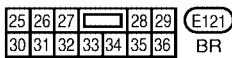
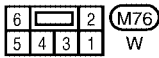
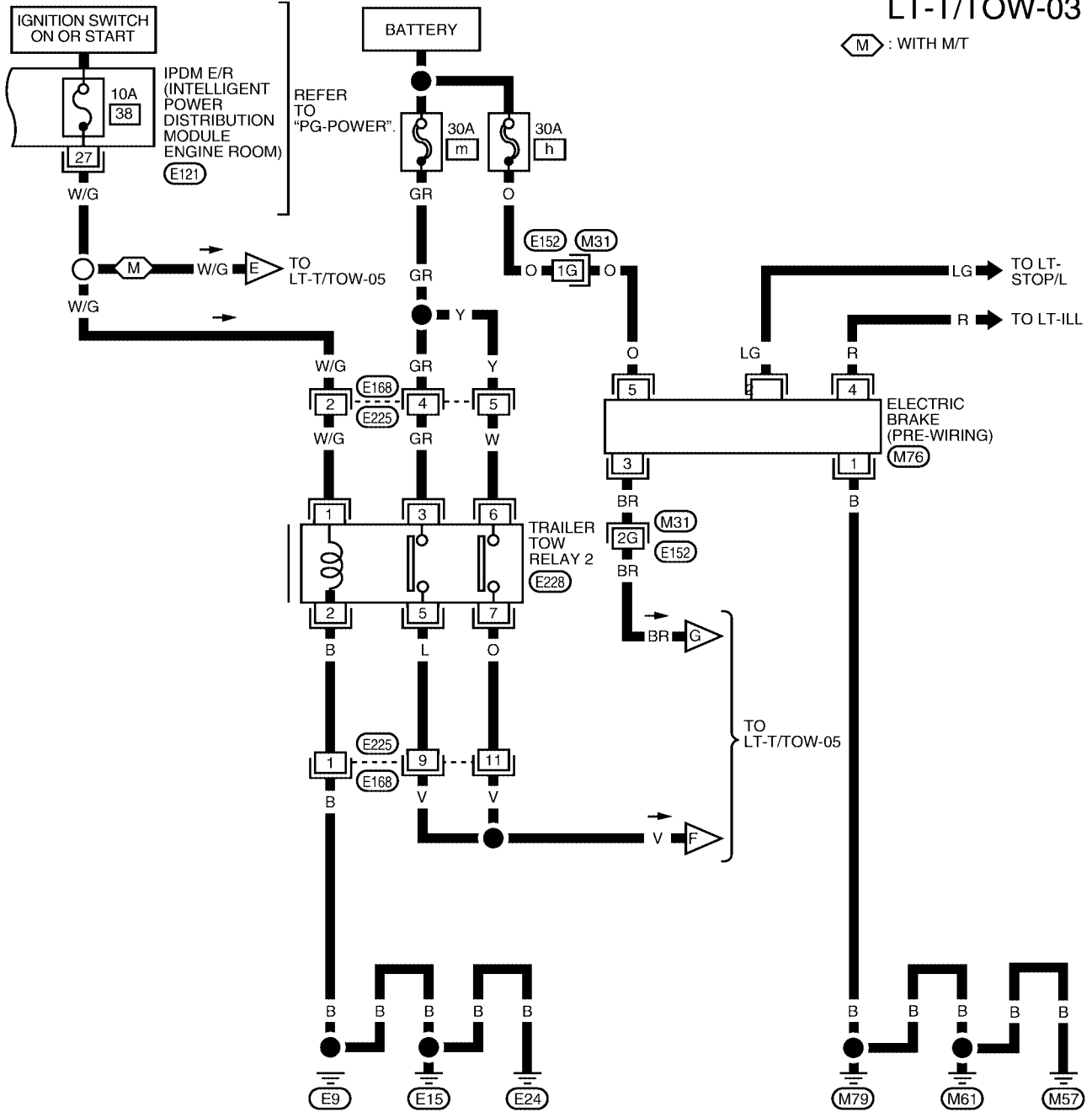

REFER TO THE FOLLOWING.  
 (M31) - SUPER MULTIPLE JUNCTION (SMJ)

WKWA4369E



# TRAILER TOW

LT-T/TOW-04

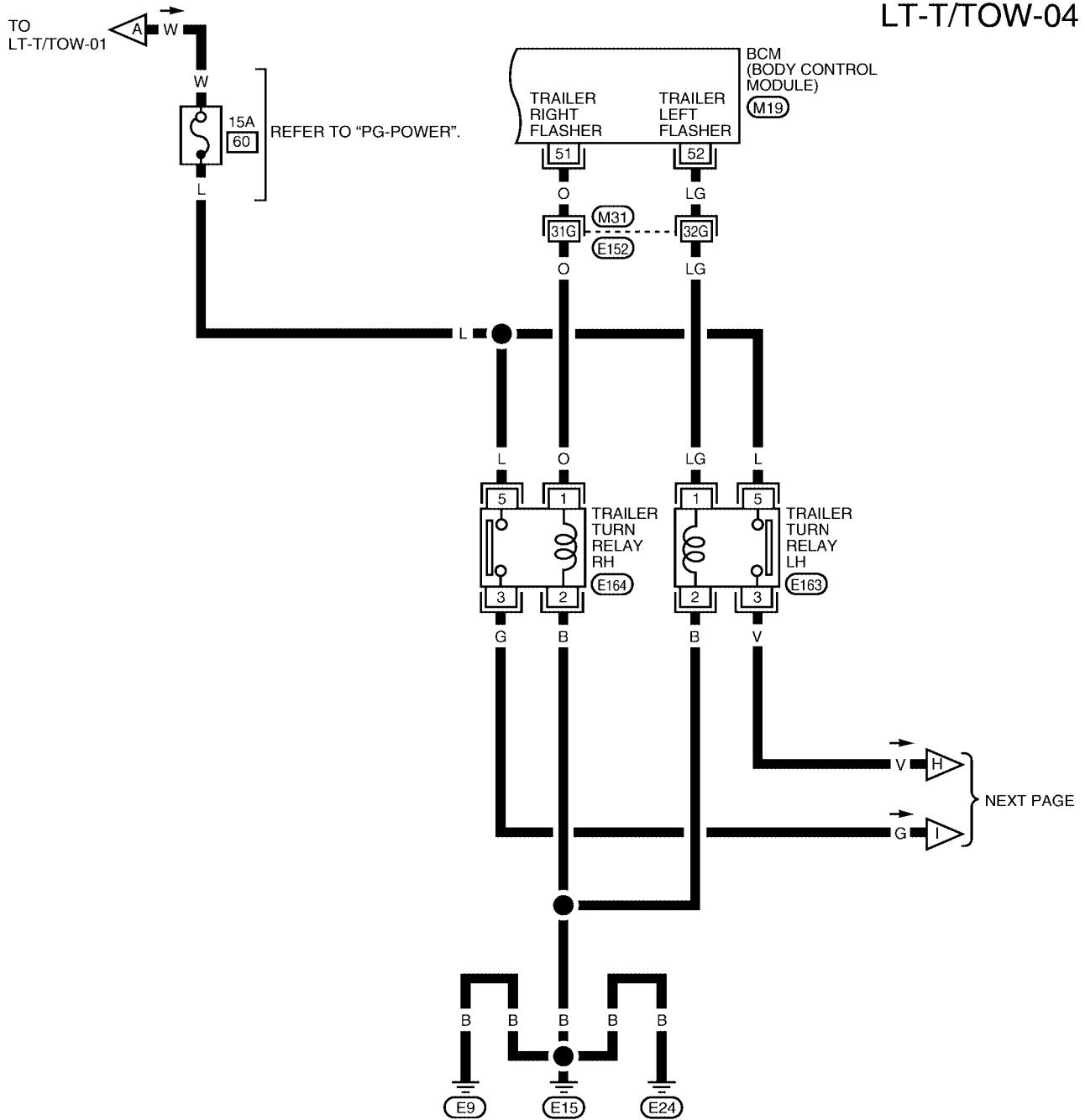

41	42	43	44	45	46	47	48	49
50	51	52	53	54	55			

M19  
B



3
5
1 X 2

E163 L  
E164 L

REFER TO THE FOLLOWING.  
M31 - SUPER MULTIPLE JUNCTION (SMJ)

WKWA4370E

# TRAILER TOW

## LT-TOW-05

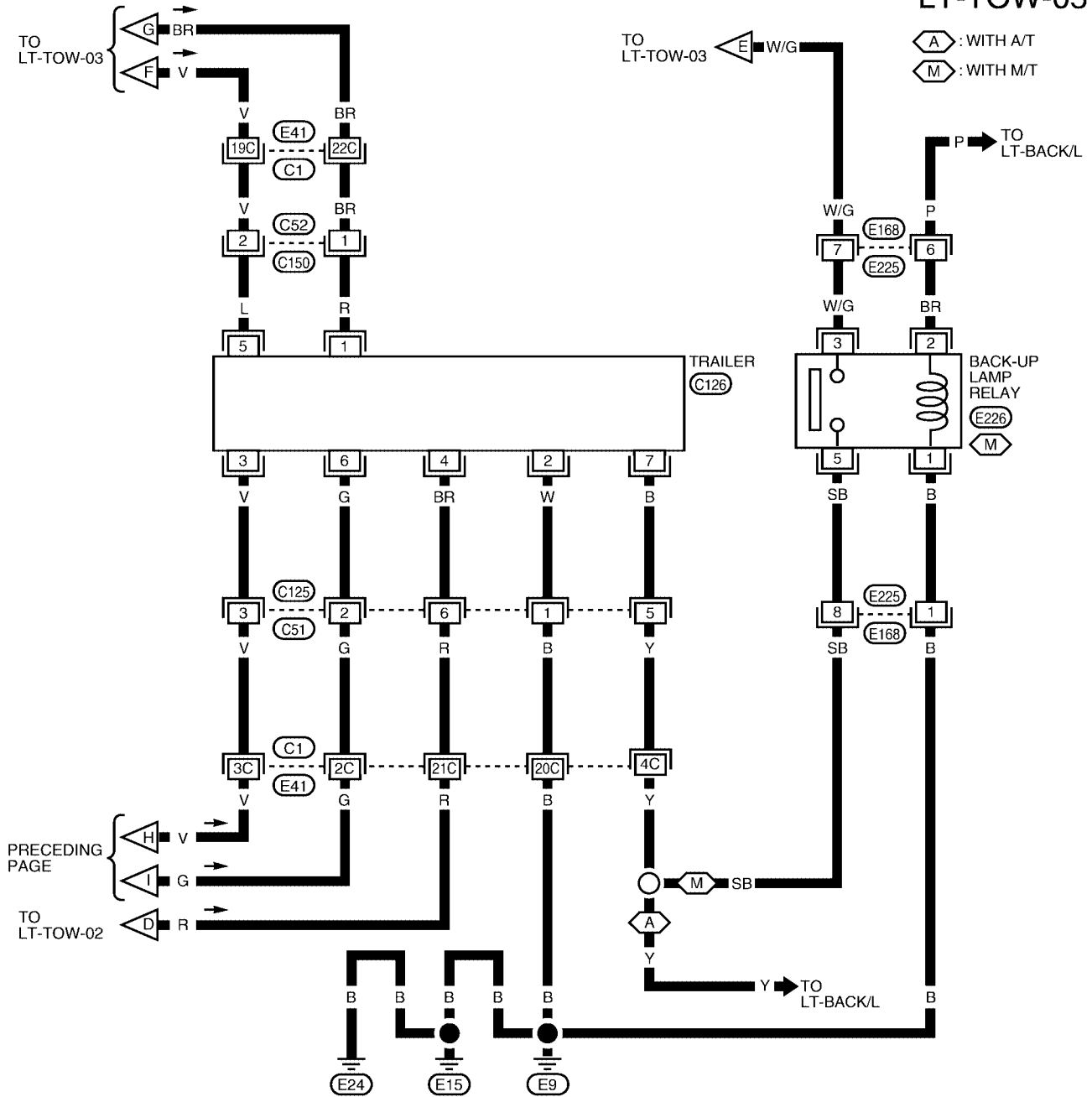

⬡ : WITH A/T  
⬡ : WITH M/T

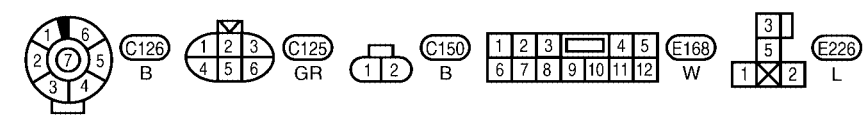

REFER TO THE FOLLOWING.  
C1 - SUPER MULTIPLE JUNCTION (SMJ)

WKWA4371E

# INTERIOR ROOM LAMP

PFP:26410

EKS00BRT

## INTERIOR ROOM LAMP

### Component Parts and Harness Connector Location

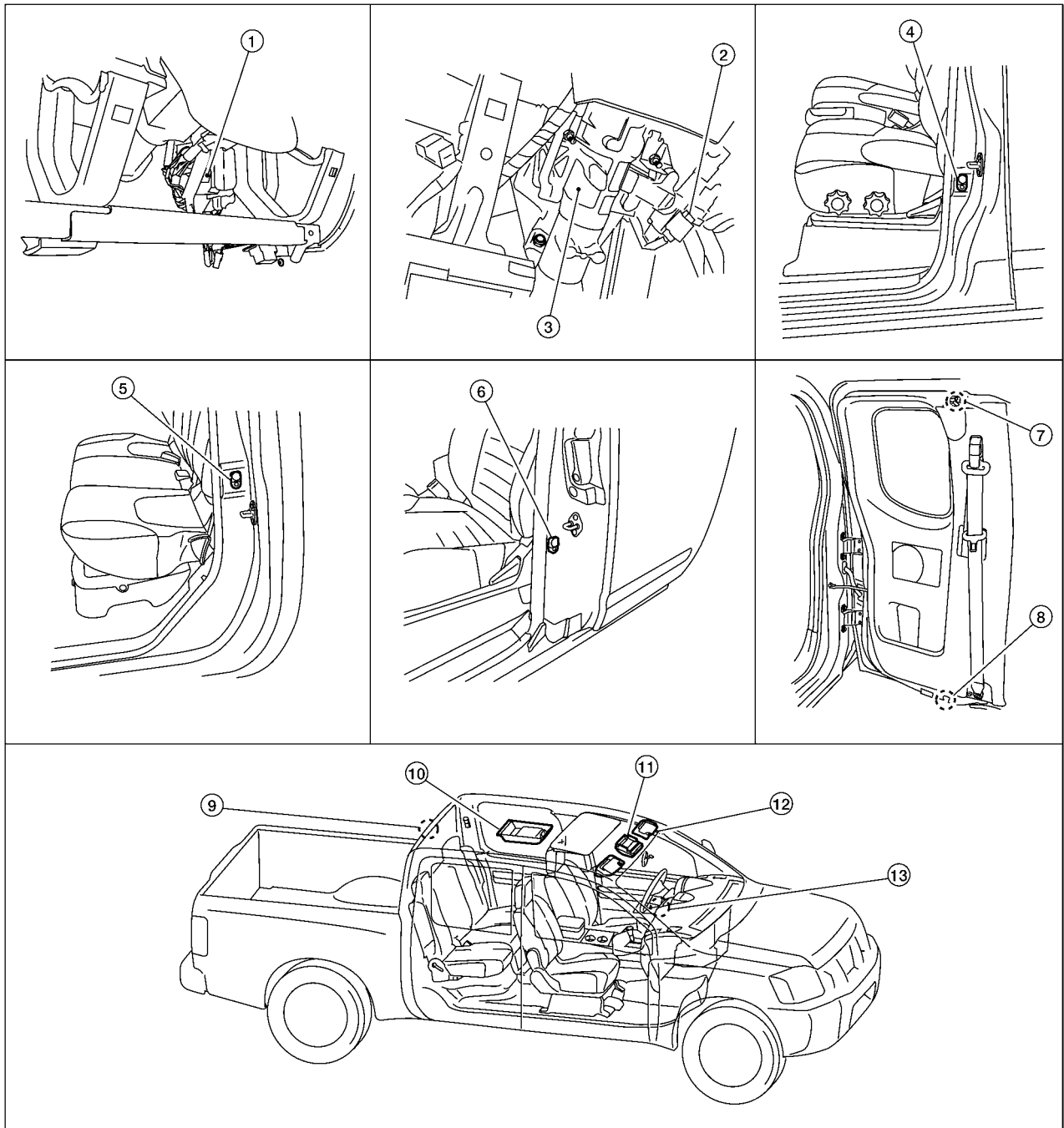

WKIA5028E

- |  |  |   |
|--|--|---|
| 1. BCM<br>M18, M19, M20<br>(view with lower instrument panel LH removed) | 2. Key switch<br>M27                                       | 3. Steering column assembly                           |
| 4. Front door switch (Crew cab)<br>LH B8<br>RH B108                      | 5. Rear door switch (Crew cab)<br>LH B18<br>RH B116        | 6. Front door switch (King cab)<br>LH D213<br>RH D314 |
| 7. Rear door switch upper (King cab)<br>LH D211<br>RH D312               | 8. Rear door switch lower (King cab)<br>LH D212<br>RH D313 | 9. Cargo lamp<br>B161                                 |

# INTERIOR ROOM LAMP

- 
- |   |  |   |
|---|--|---|
| 10. Room lamp 2nd row<br>R10              | 11. Front room/map lamp assembly<br>(with front map lamps)<br>R9 | 12. Vanity lamp (with vanity lamps)<br>LH B80<br>RH B81 |
| 13. Ignition keyhole illumination<br>M150 |  |   |

## System Description

### MODELS WITHOUT POWER DOOR LOCKS

EKS00CNF

### Power Supply and Ground

Power is supplied at all times

- through 10A fuse (No. 25, located in the fuse and fusible link box)
- to key switch terminal 2, and
- through 10A fuse [No. 18, located in the fuse block (J/B)]
- to BCM (body control module) terminal 57, and
- to ignition keyhole illumination terminal 1, and
- to room lamp 2nd row terminal 2, and
- to front room/map lamp assembly terminal 1, and
- to cargo lamp relay terminals 2 and 5
- through 50A fusible link (letter **g**, located in the fuse and fusible link box)
- to BCM terminal 70.

When the key is inserted in key switch, power is supplied

- through key switch terminal 1
- to BCM terminal 37.

With the ignition switch in the ON or START position, power is supplied

- through 10A fuse [No. 1, located in the fuse block (J/B)]
- to BCM terminal 38.

Ground is supplied

- to BCM terminal 67
- through grounds M57, M61 and M79.

### Switch Operation

When the cargo lamp switch is ON, ground is supplied

- to BCM terminal 31
- through cargo lamp switch terminal 1
- through cargo lamp switch terminal 3
- through grounds M57, M61 and M79, and
- to cargo lamp relay terminal 1
- through BCM terminal 50.

Power is supplied

- through 10A fuse [No. 18, located in the fuse block (J/B)]
- to cargo lamp relay terminals 2 and 5.

When the BCM supplies ground to terminal 50, the cargo lamp relay energizes. When this relay is energized, power is supplied

- to high mounted stop lamp (cargo lamp) terminal 3
- through cargo lamp relay terminal 3.

Ground is supplied

- to high mounted stop lamp (cargo lamp) terminal 2
- through grounds B117 and B132.

With power and ground supplied, the cargo lamp illuminates.

When any door switch is ON (door is opened), ground is supplied

- to front room/map lamp assembly terminal 2 (with front map lamps)

# INTERIOR ROOM LAMP

- to room lamp 2nd row terminal 1
- to ignition keyhole illumination terminal 2
- through diode 6 terminal 2 (front door switch LH only)
- through diode 6 terminal 1 (front door switch LH only)
- through door switch terminal 1
- through front door switch LH or RH terminal 3 (king cab)
- through grounds B7 and B19 LH or B117 and B132 RH (king cab), or
- through case ground of any door switch (crew cab).

When the front door LH is open, ground is supplied

- to ignition keyhole illumination terminal 2
- through front door switch terminal 1
- through front door switch terminal 3 (king cab)
- through grounds B7 and B19 (king cab), or
- through case ground of the front door switch LH (crew cab).

Power is supplied

- through 10A fuse [No. 18, located in the fuse block (J/B)]
- to front room/map lamp assembly terminal 1 (with front map lamps)
- to room lamp 2nd row terminal 2, and
- to ignition keyhole illumination terminal 1.

When room lamp 2nd row is ON, ground is supplied through room lamp 2nd row case ground.

When front room/map lamp assembly switch is ON, ground is supplied

- to front room/map lamp assembly terminal 3
- through grounds M57, M61 and M79.

## MODELS WITH POWER DOOR LOCKS

When front room/map lamp and room lamp 2nd row switch is in DOOR position, front room/map lamp and room lamp 2nd row ON/OFF is controlled by timer according to signals from switches including key switch, front door switch LH, unlock signal from keyfob (if equipped), door lock and unlock switch, key cylinder switch and ignition switch.

When front room/map lamp and room lamp 2nd row turns ON, there is a gradual brightening over 1 second.

When front room/map lamp and room lamp 2nd row turns OFF, there is a gradual dimming over 1 second.

The front room/map lamp and room lamp 2nd row timer is controlled by the BCM (body control module).

Front room/map lamp and room lamp 2nd row timer control settings can be changed with CONSULT-II.

Ignition keyhole illumination turns ON when front door LH is opened (door switch ON) or key is removed from key cylinder switch. Illumination turns OFF when front door LH is closed (door switch OFF).

## Power Supply and Ground

Power is supplied at all times

- through 10A fuse (No. 25, located in the fuse and fusible link box)
- to key switch terminal 2, and
- through 10A fuse [No. 18, located in the fuse block (J/B)]
- to BCM terminal 57, and
- to cargo lamp relay terminals 2 and 5, and
- through 50A fusible link (letter **g**, located in the fuse and fusible link box)
- to BCM terminal 70.

When the key is inserted in key switch, power is supplied

- through key switch terminal 1
- to BCM terminal 37.

With the ignition switch in the ON or START position, power is supplied

- through 10A fuse [No. 1, located in the fuse block (J/B)]
- to BCM terminal 38.

Ground is supplied

A  
B  
C  
D  
E  
F  
G  
H  
I  
J  
LT  
L  
M

## INTERIOR ROOM LAMP

---

- to BCM terminal 67
- through grounds M57, M61 and M79.

When the front door LH is opened, ground is supplied

- to BCM terminal 47
- through front door switch LH terminal 2
- through front door switch LH terminal 3 (king cab)
- through grounds B7 and B19 (king cab), or
- through case ground of front door switch LH (crew cab).

When the front door RH is opened, ground is supplied

- to BCM terminal 12
- through front door switch RH terminal 2
- through front door switch RH terminal 3 (king cab)
- through grounds B117 and B132 (king cab), or
- through case ground of front door switch RH (crew cab).

When the rear door LH is opened, ground is supplied

- to BCM terminal 47 (king cab)
- through rear door switches lower and upper LH terminal 1
- through rear door switches lower and upper LH terminal 2
- through grounds B7 and B19, or
- to BCM terminal 48 (crew cab)
- through rear door switch LH terminal 2
- through case ground of rear door switch LH.

When the rear door RH is opened, ground is supplied

- to BCM terminal 12 (king cab)
- through rear door switches lower and upper RH terminal 1
- through rear door switches lower and upper RH terminal 2
- through grounds B117 and B132, or
- to BCM terminal 13 (crew cab)
- through rear door switch RH terminal 2
- through case ground of rear door switch RH.

When the front door LH or RH is unlocked by the door lock/unlock switch, BCM receives ground signal

- to BCM terminal 46
- through main power window and door lock/unlock switch terminal 11 or power window and door lock/unlock switch RH terminal 2
- through main power window and door lock/unlock switch terminal 14 or power window and door lock/unlock switch RH terminal 3
- through grounds M57, M61 and M79.

When the front door LH is unlocked by the key, the BCM receives ground signal

- to BCM terminal 7
- through front door lock assembly LH (key cylinder switch) terminal 3
- through front door lock assembly LH (key cylinder switch) terminal 4
- through grounds M57, M61 and M79.

When a signal, or combination of signals is received by BCM, ground is supplied

- to front room/map lamp assembly terminal 2 (with front map lamps)
- to room lamp 2nd row terminal 1
- through BCM terminal 63.

### Switch Operation

When the cargo lamp switch is ON, ground is supplied

- to BCM terminal 31

# INTERIOR ROOM LAMP

- through cargo lamp switch terminal 1
- through cargo lamp switch terminal 3
- through grounds M57, M61 and M79, and
- to cargo lamp relay terminal 1
- through BCM terminal 50.

Power is supplied

- through 10A fuse [No. 18, located in the fuse block (J/B)]
- to cargo lamp relay terminals 2 and 5.

When the BCM supplies ground to terminal 50, the cargo lamp relay energizes. When this relay is energized, power is supplied

- to high mounted stop lamp (cargo lamp) terminal 3
- through cargo lamp relay terminal 3.

Ground is supplied

- to high mounted stop lamp (cargo lamp) terminal 2
- through grounds B117 and B132.

With power and ground supplied, the cargo lamp illuminates.

When any door switch is ON (door is opened), ground is supplied

- to front room/map lamp assembly terminal 2
- to room lamp 2nd row terminal 1
- through BCM terminal 63, and
- to ignition keyhole illumination terminal 2
- through BCM terminal 1.

Power is supplied

- through BCM terminal 56
- to ignition keyhole illumination terminal 1
- to front room/map lamp assembly terminal 1 (with front map lamps)
- to vanity lamp LH and RH terminal 1 (with vanity lamps), and
- to room lamp 2nd row terminal 2.

When front room/map lamp assembly switch is ON, ground is supplied

- through front room/map lamp assembly terminal 3
- to grounds M57, M61 and M79.

When vanity lamp LH or RH is ON, ground is supplied

- to vanity lamp LH or RH terminal 2
- through grounds B7 and B19.

When room lamp 2nd row is ON, ground is supplied through room lamp case ground.

With power and ground supplied, the lamps illuminate.

## Room Lamp Timer Operation

When lamp switch is in DOOR position, and when all conditions below are met, BCM performs timer control (maximum 30 seconds) for interior room lamp and map lamp ON/OFF.

Power is supplied

- through 10A fuse [No. 25, located in the fuse block (J/B)]
- to key switch terminal 2.

Key is removed from ignition key cylinder (key switch OFF), power will not be supplied to BCM terminal 37.

Ground is supplied

- to BCM terminal 46
- through main power window and door lock/unlock switch terminal 11.

At the time that front door LH is opened, BCM detects that front door LH is unlocked. It determines that interior room lamp and map lamp timer operation conditions are met, and turns the interior room lamps ON for 30 seconds.

Key is in ignition key cylinder (key switch ON), power is supplied

A  
B  
C  
D  
E  
F  
G  
H  
I  
J  
LT  
L  
M

## INTERIOR ROOM LAMP

---

- through key switch terminal 1
- to BCM terminal 37.

When key is removed from key switch (key switch OFF), power supply to BCM terminal 37 is terminated. BCM detects that key has been removed, determines that interior room lamp and map lamp timer conditions are met, and turns the interior room lamps ON for 30 seconds.

When front door LH opens → closes, and the key is not inserted in the key switch (key switch OFF), BCM terminal 47 changes between 0V (door open) → 12V (door closed). The BCM determines that conditions for interior room lamp operation are met and turns the interior room lamp ON for 30 seconds.

Timer control is canceled under the following conditions.

- Front door LH is locked [when locked by keyfob (if equipped), main power window and door lock/unlock switch, or front door lock assembly LH (key cylinder switch)]
- Front door LH is opened (front door switch LH turns ON)
- Ignition switch ON.

### Interior Lamp Battery Saver Control

If interior lamp is left ON, it will not be turned off even when door is closed.

BCM turns off interior lamp automatically to save battery 30 minutes after ignition switch is turned off.

BCM controls interior lamps listed below:

- Vanity lamp (with vanity lamps)
- Front room/map lamp
- Room lamp 2nd row
- Ignition keyhole illumination

After lamps turn OFF by the battery saver system, the lamps illuminate again when

- signal received from keyfob (if equipped), main power window and door lock/unlock switch or front door lock assembly LH (key cylinder switch) is locked or unlocked
- door is opened or closed
- key is removed from ignition key cylinder or inserted in ignition key cylinder.

Interior lamp battery saver control period can be changed by the function setting of CONSULT-II.



# INTERIOR ROOM LAMP

## Schematic / With Power Door Locks

EKS00BRV

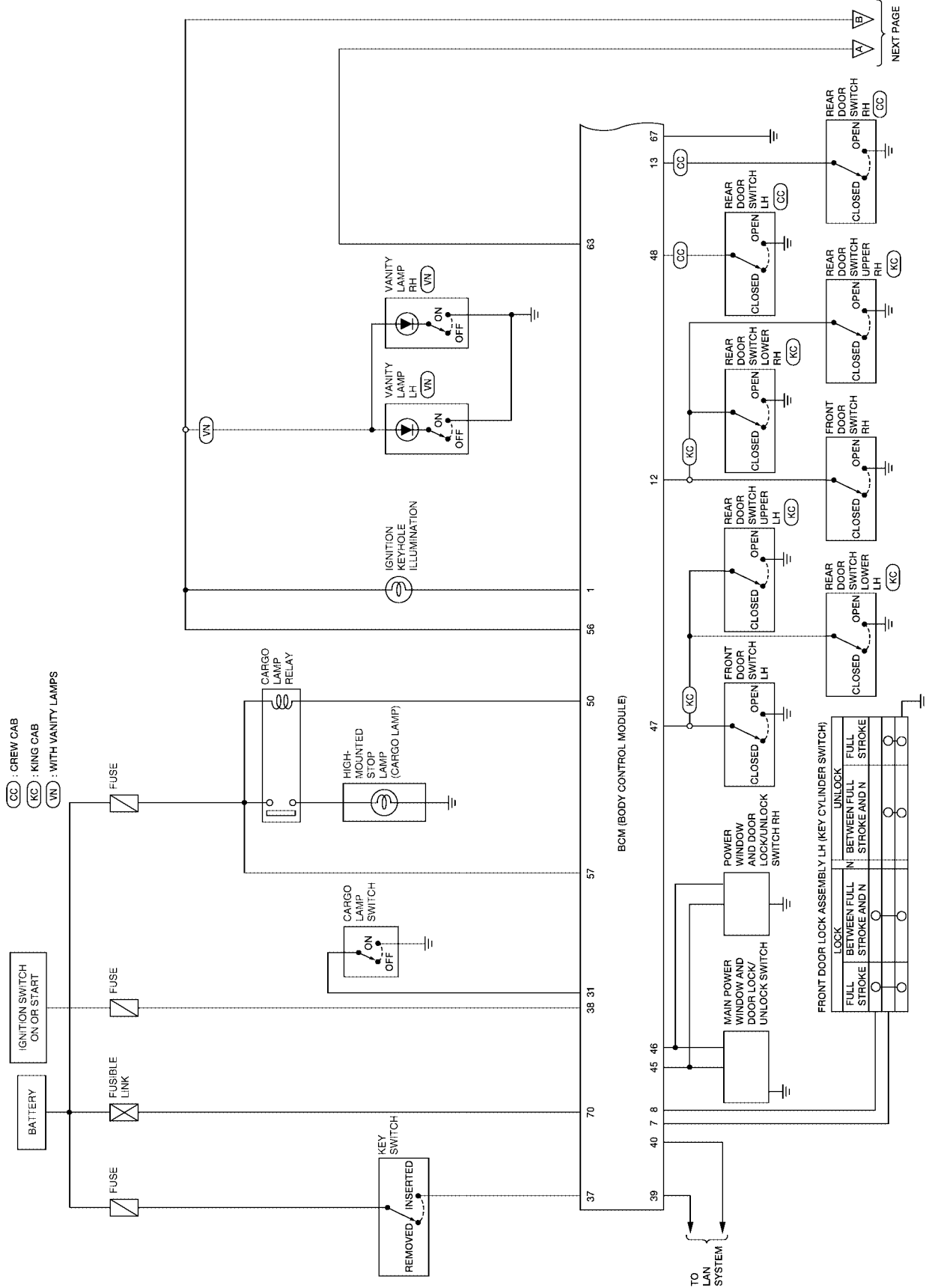

WKWA4372E

A  
B  
C  
D  
E  
F  
G  
H  
I  
J  
K  
L  
M

LT

# INTERIOR ROOM LAMP

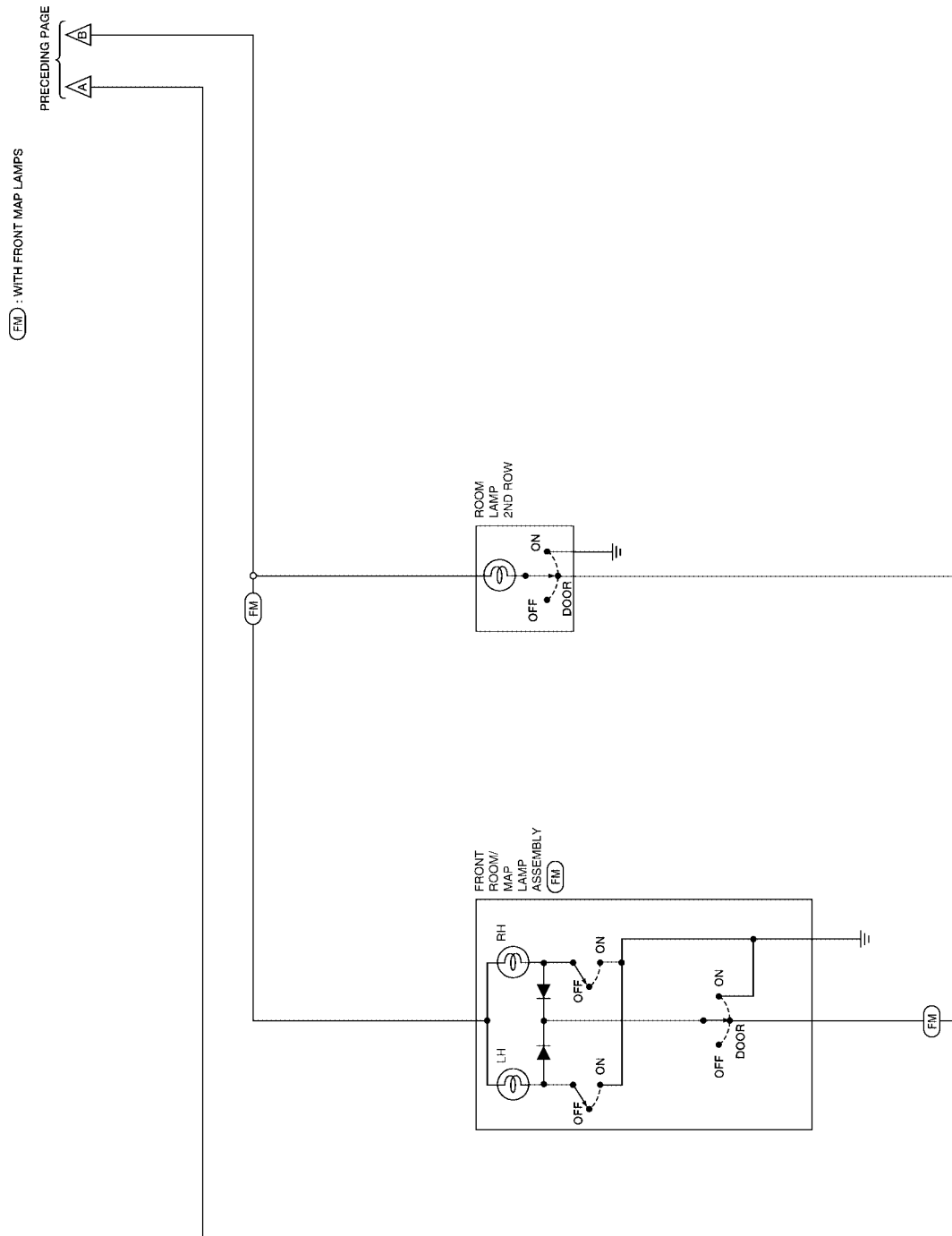

WKWA4373E

# INTERIOR ROOM LAMP

## Wiring Diagram — INT/L — / With Power Door Locks

EKS00BRW

LT-INT/L-01

— : DATA LINE

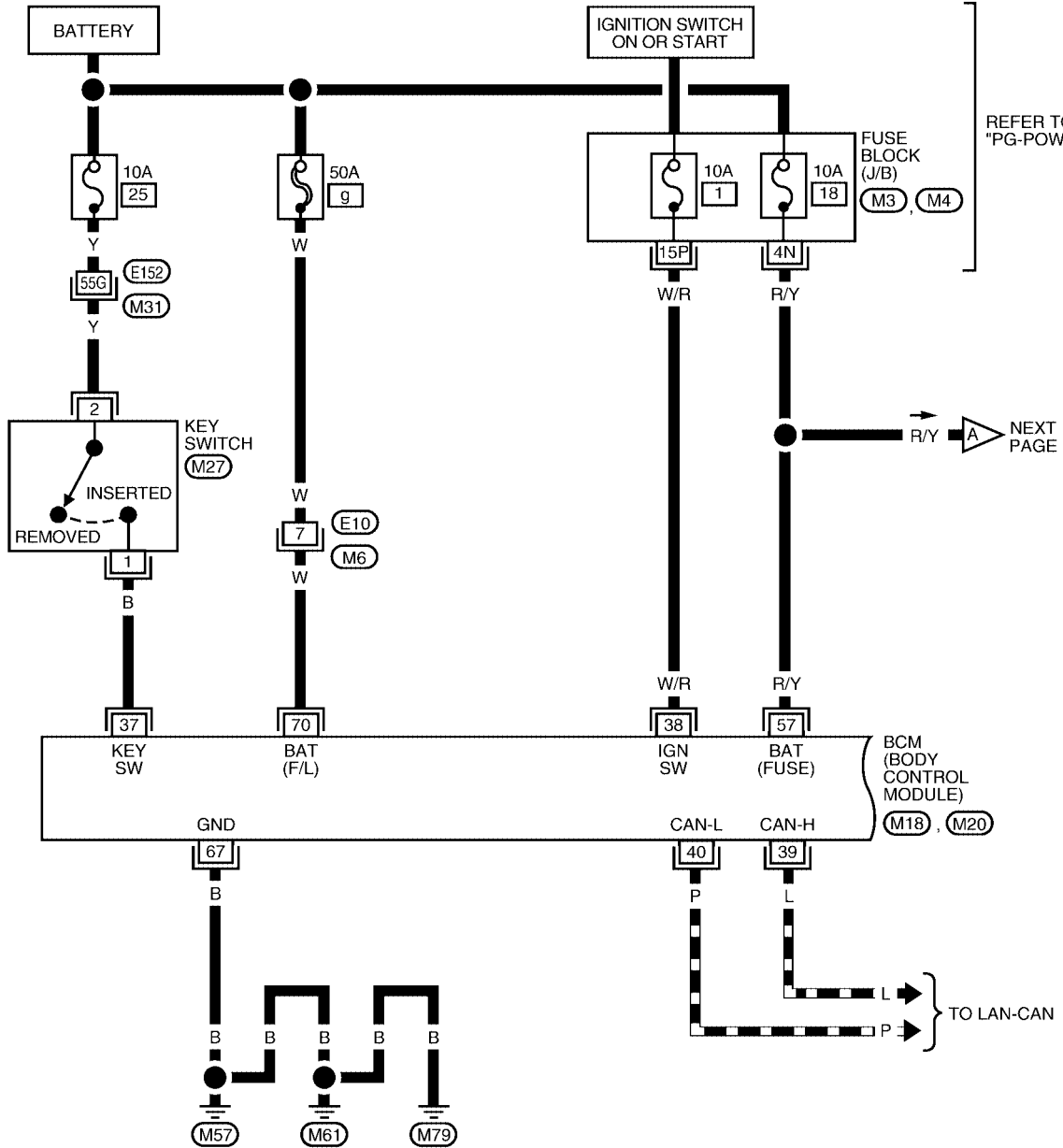

A  
B  
C  
D  
E  
F  
G  
H  
I  
J  
LT  
L  
M

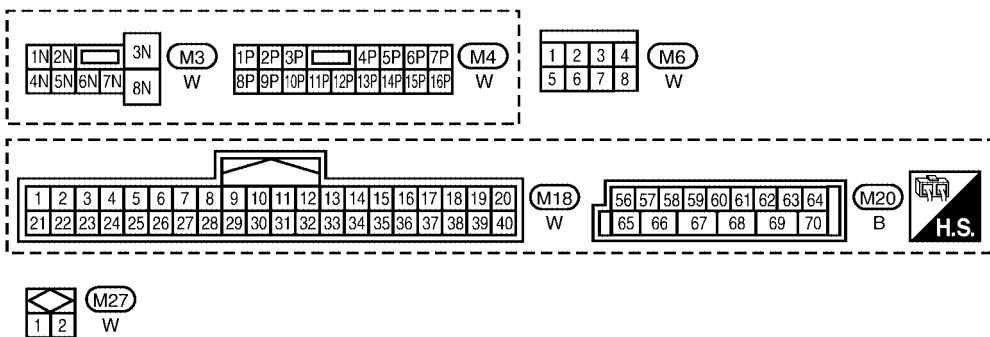

REFER TO THE FOLLOWING.

M31 - SUPER MULTIPLE JUNCTION (SMJ)

WKWA4374E

# INTERIOR ROOM LAMP

LT-INT/L-02

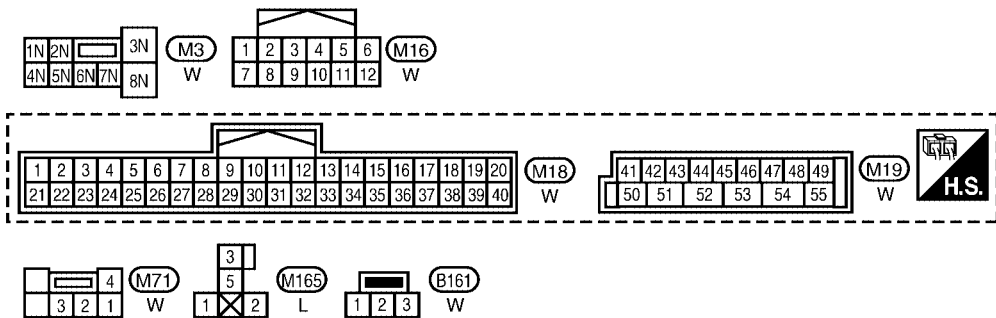
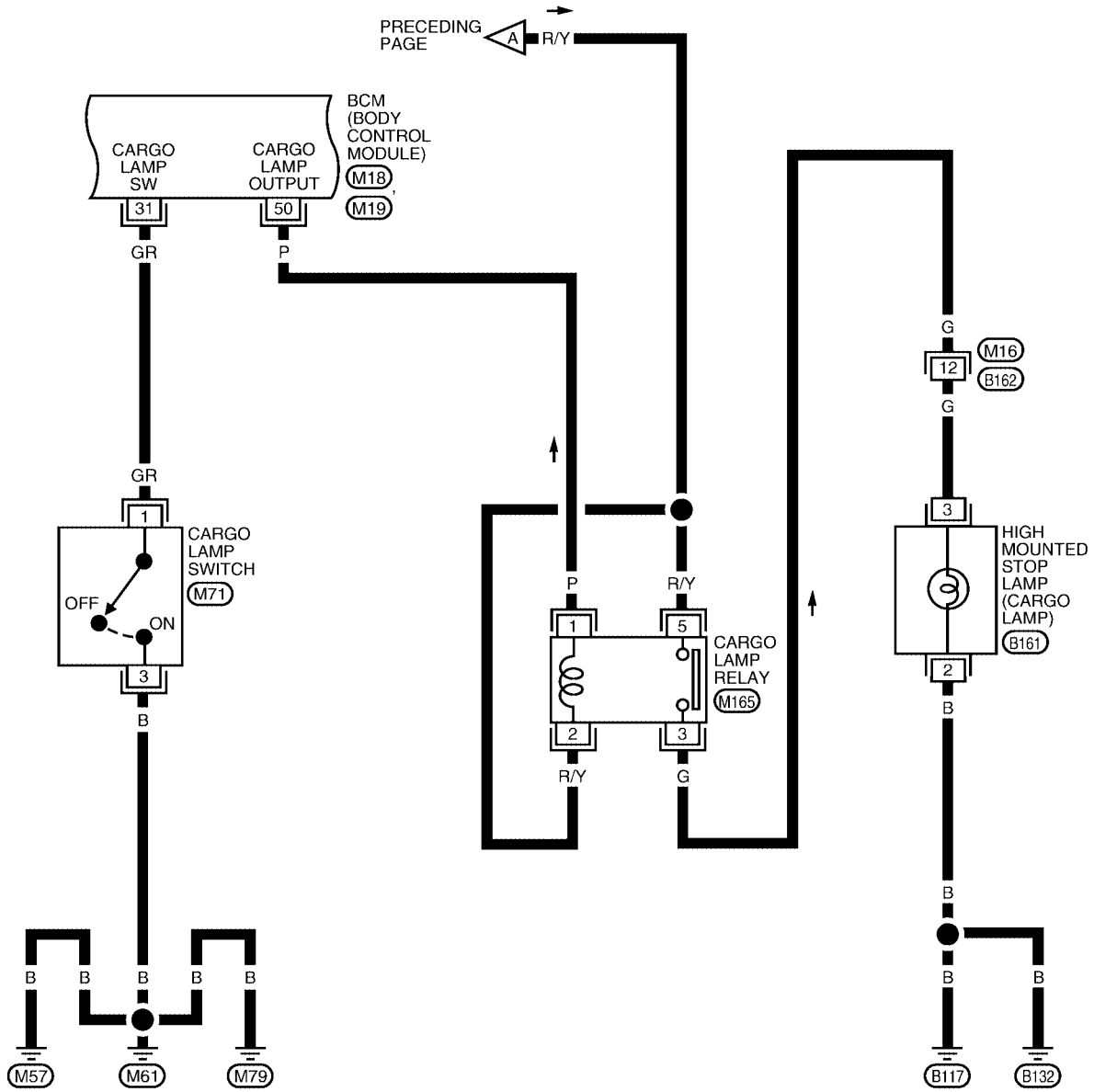

WKWA4375E

# INTERIOR ROOM LAMP

LT-INT/L-03

CC : CREW CAB

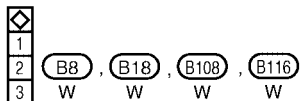
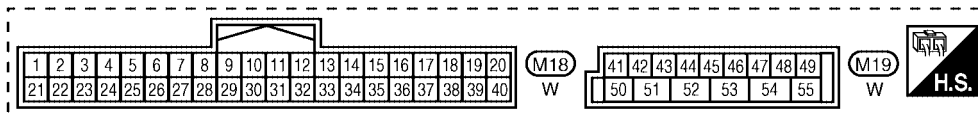
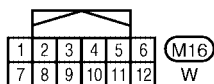
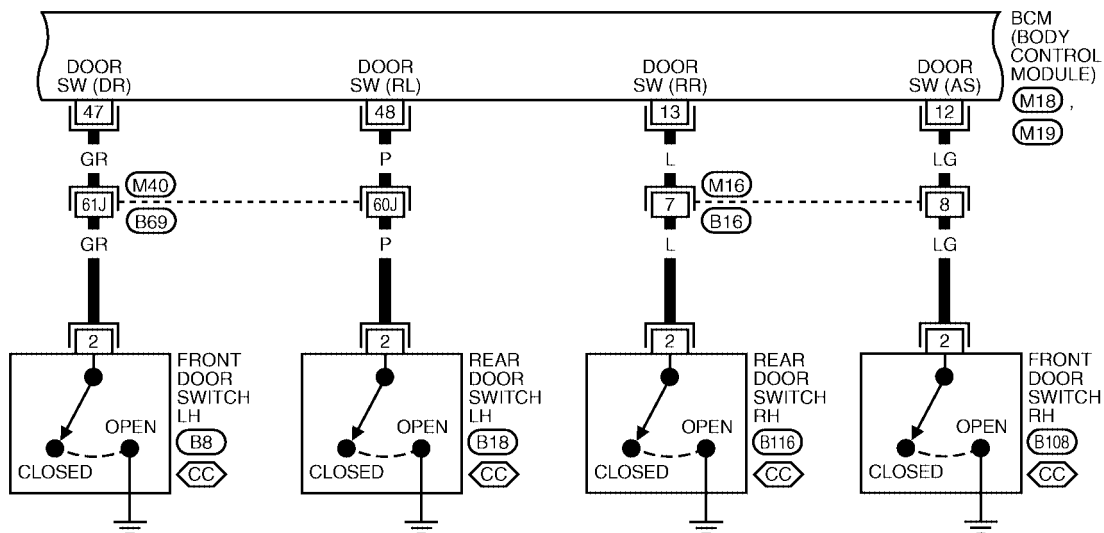

REFER TO THE FOLLOWING.  
 (M40) - SUPER MULTIPLE JUNCTION (SMJ)

WKWA2979E

# INTERIOR ROOM LAMP

LT-INT/L-04

 : KING CAB

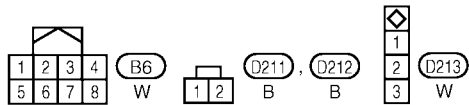
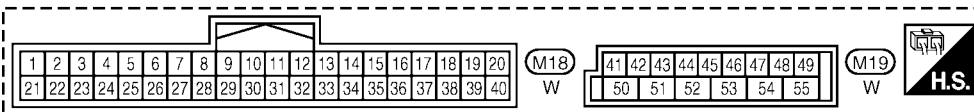
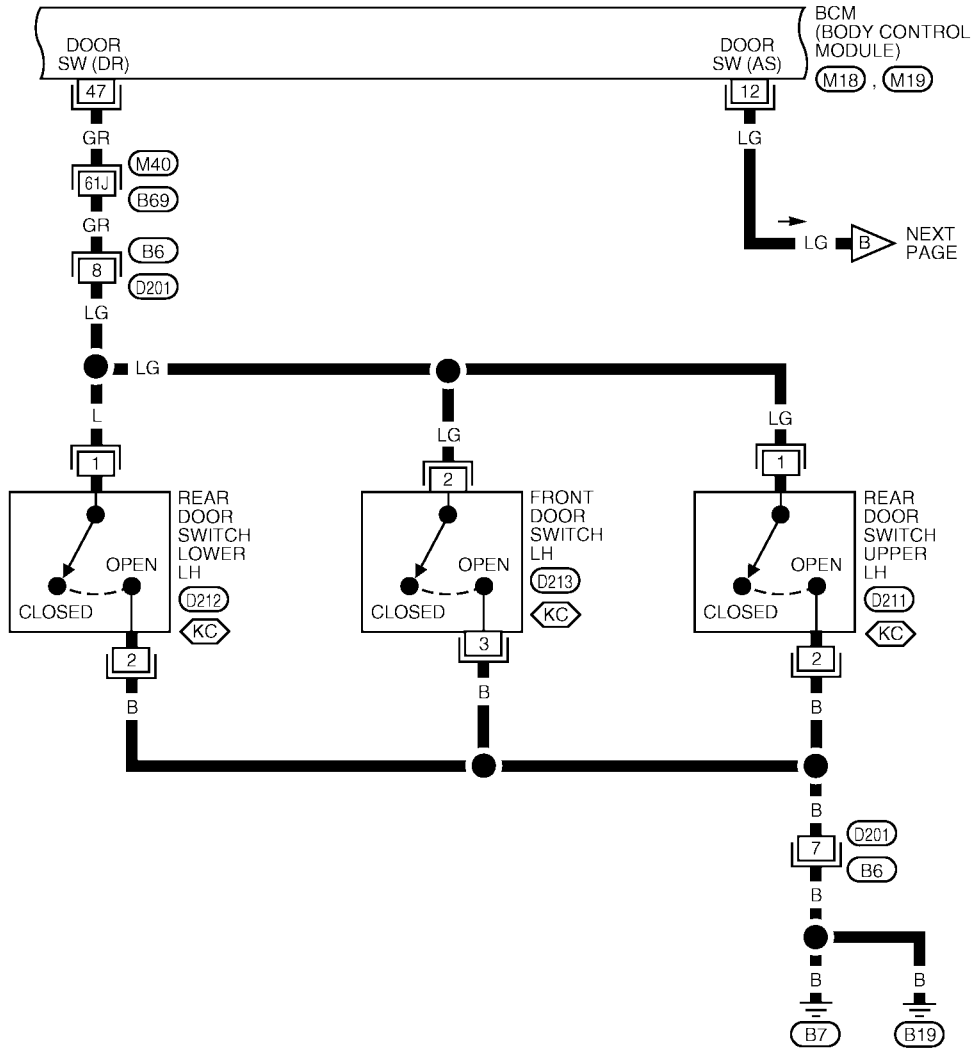

REFER TO THE FOLLOWING.

 - SUPER MULTIPLE JUNCTION (SMJ)

WKWA2874E

# INTERIOR ROOM LAMP

LT-INT/L-05

: KING CAB

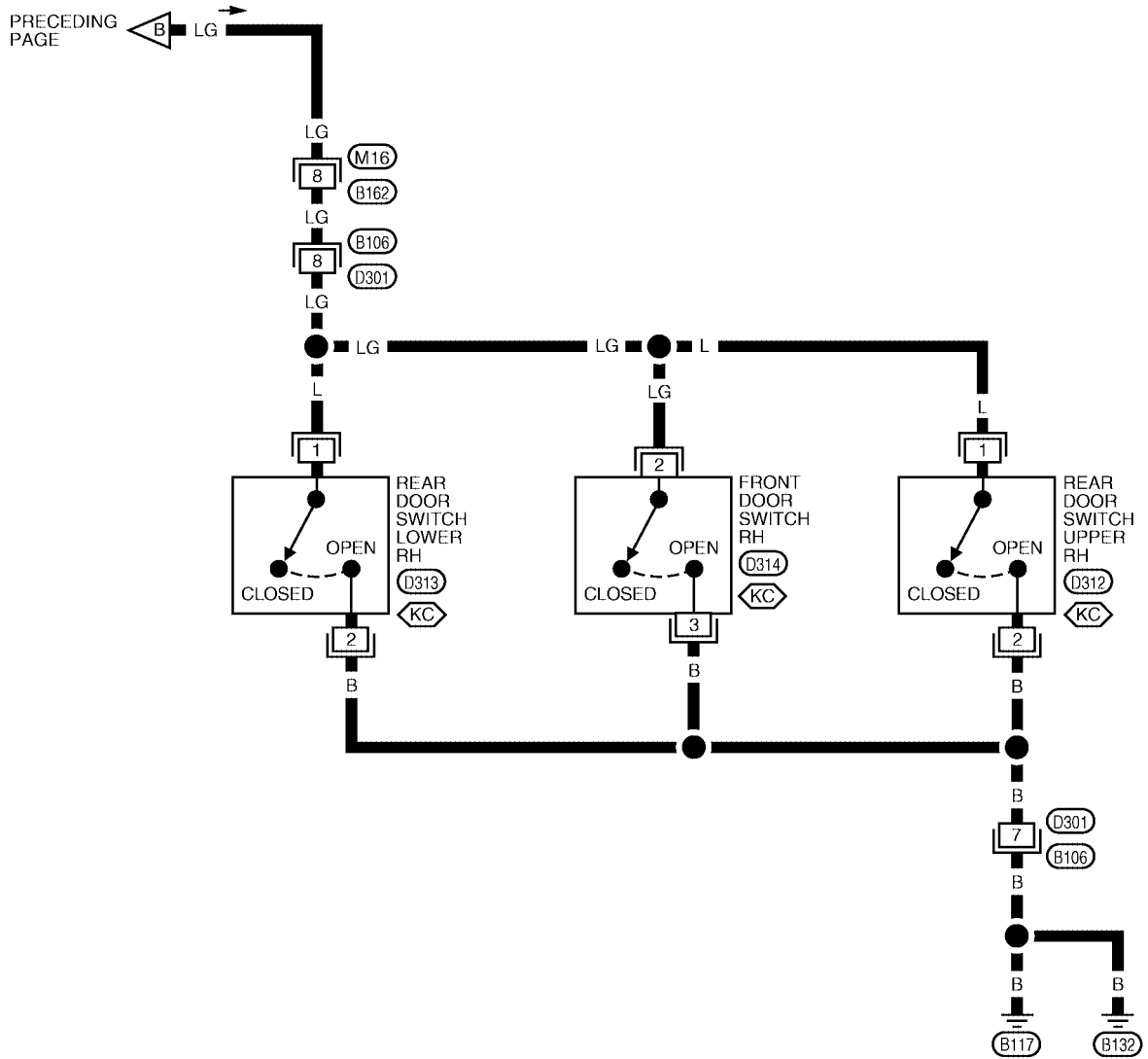

A  
B  
C  
D  
E  
F  
G  
H  
I  
J  
LT  
L  
M

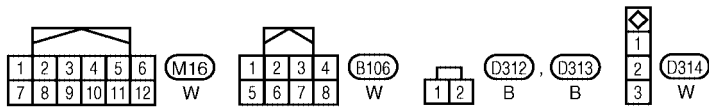

WKWA2875E

# INTERIOR ROOM LAMP

LT-INT/L-06

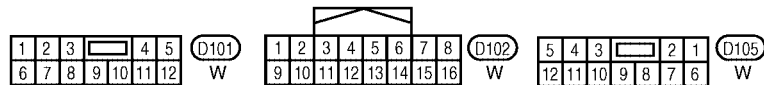
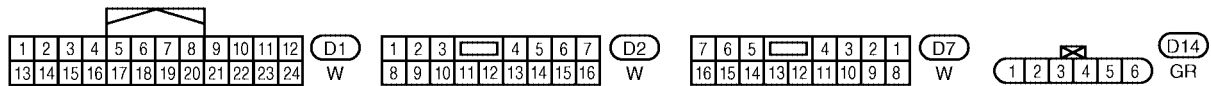
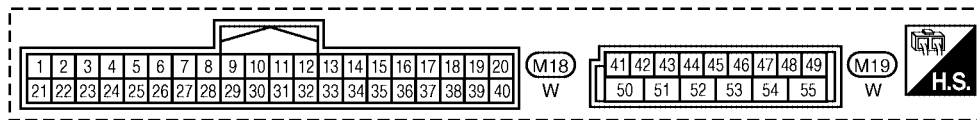
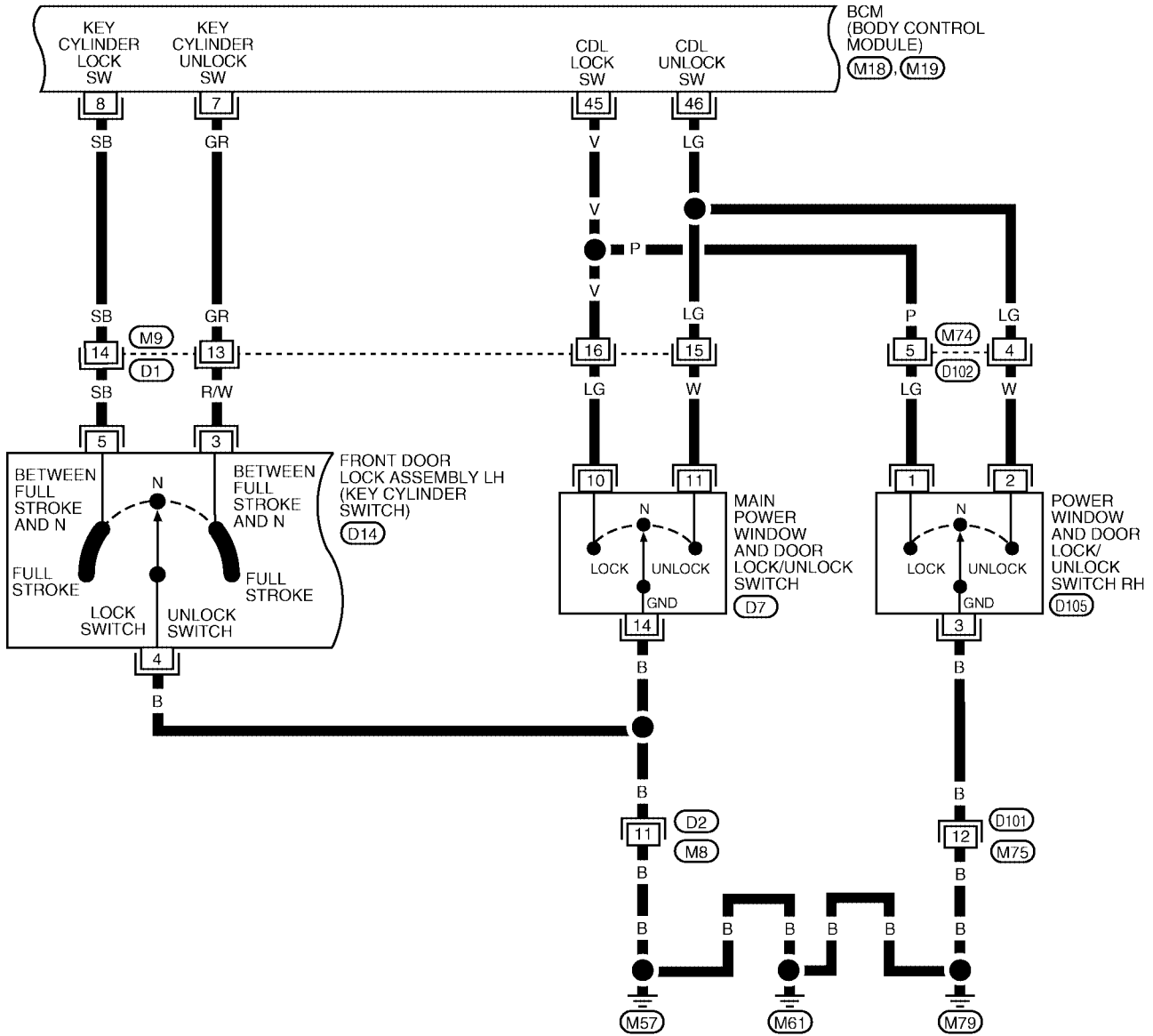

WKWA2876E



# INTERIOR ROOM LAMP

LT-INT/L-07

: WITH VANITY LAMPS  
 : WITH FRONT MAP LAMPS

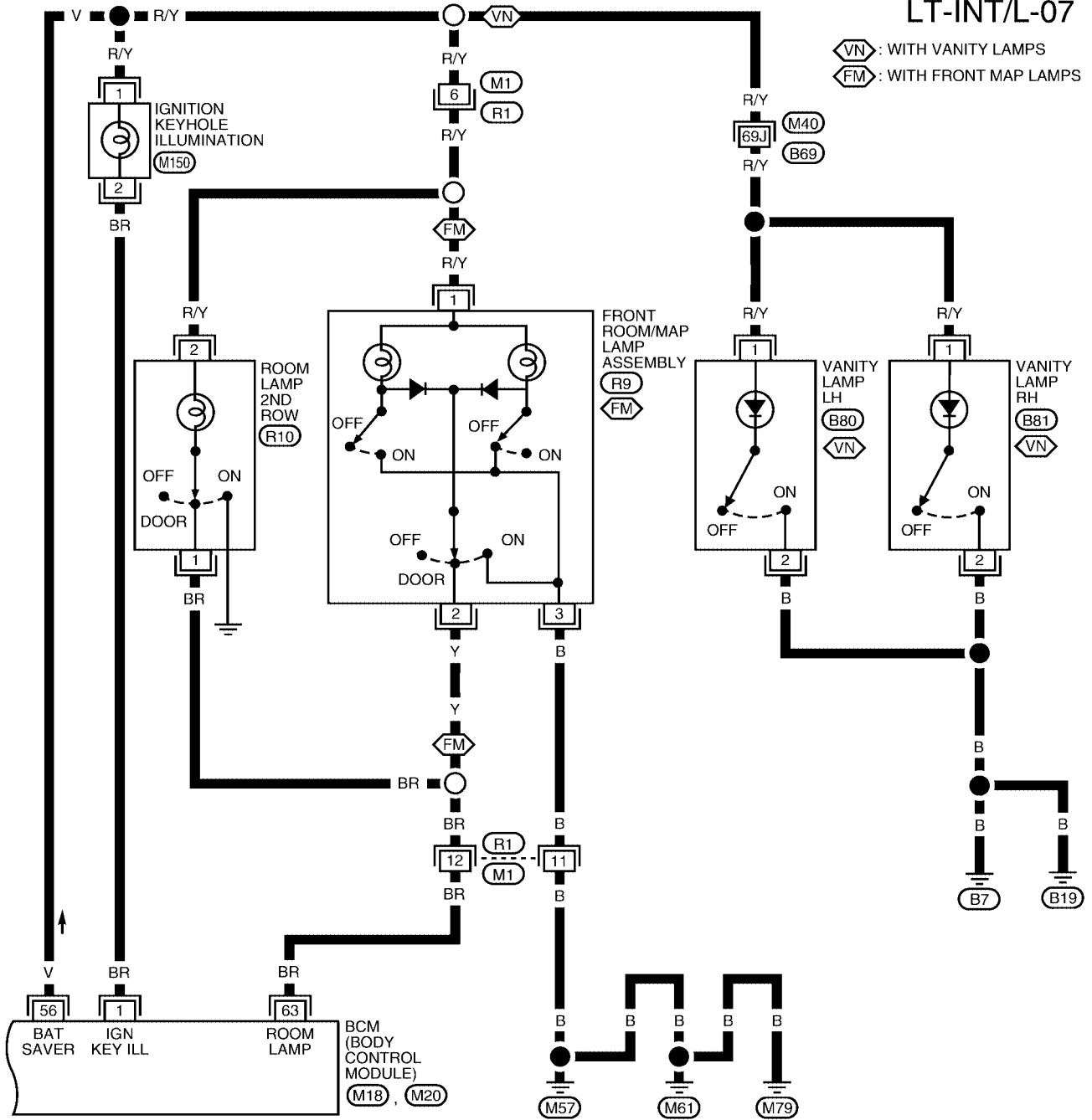

A  
B  
C  
D  
E  
F  
G  
H  
I  
J  
LT  
L  
M

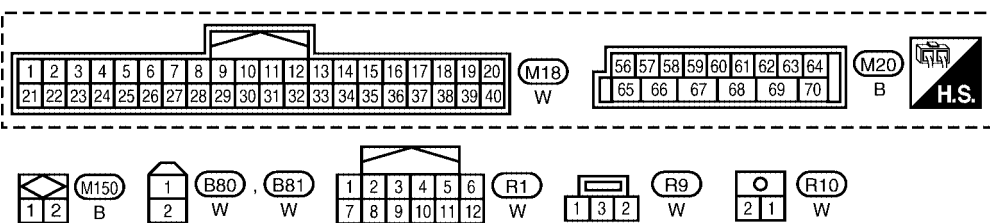

REFER TO THE FOLLOWING.  
 - SUPER MULTIPLE JUNCTION (SMJ)

WKWA4376E

# INTERIOR ROOM LAMP

## Schematic / Without Power Door Locks

EKS00FPE

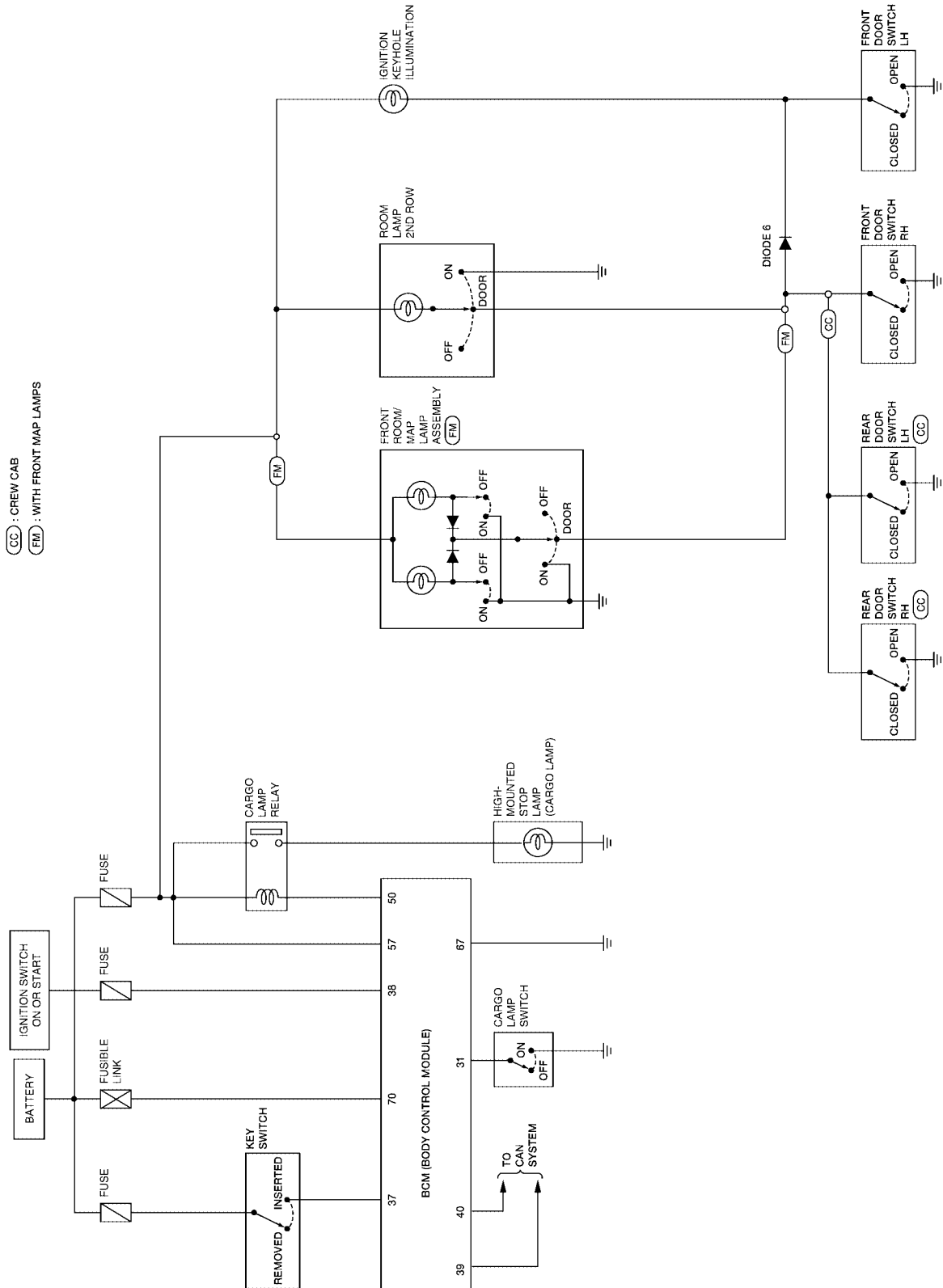

WKWA4377E

# INTERIOR ROOM LAMP

## Wiring Diagram — INT/L — / Without Power Door Locks

EKS00FPF

LT-INT/L-08

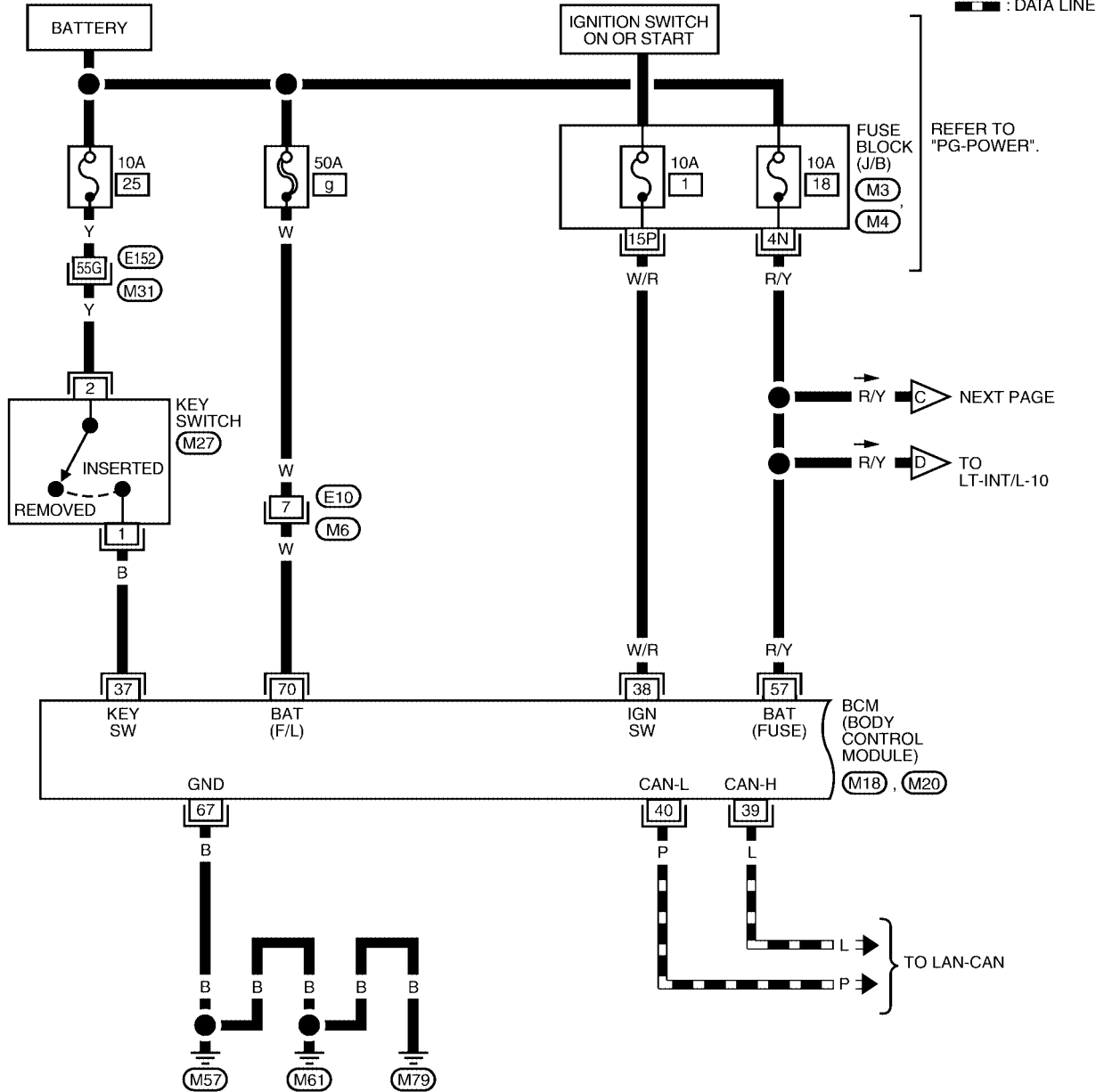

A  
B  
C  
D  
E  
F  
G  
H  
I  
J  
LT  
L  
M

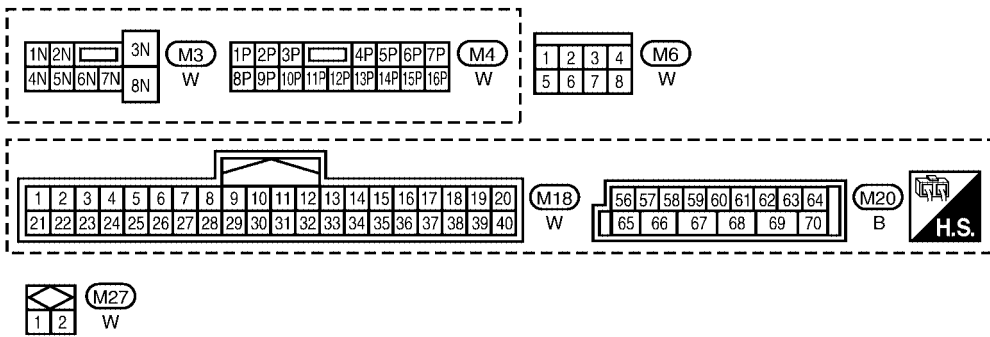

# INTERIOR ROOM LAMP

LT-INT/L-09

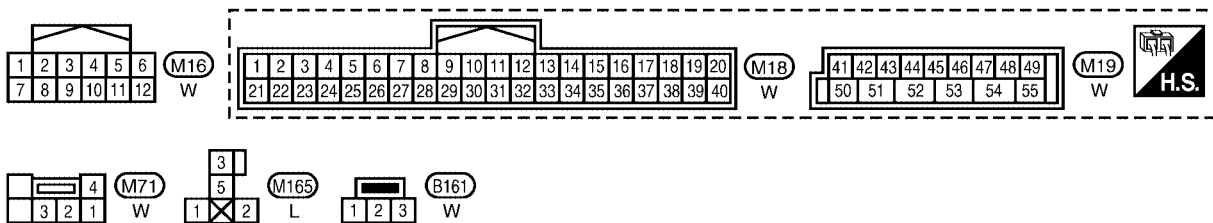
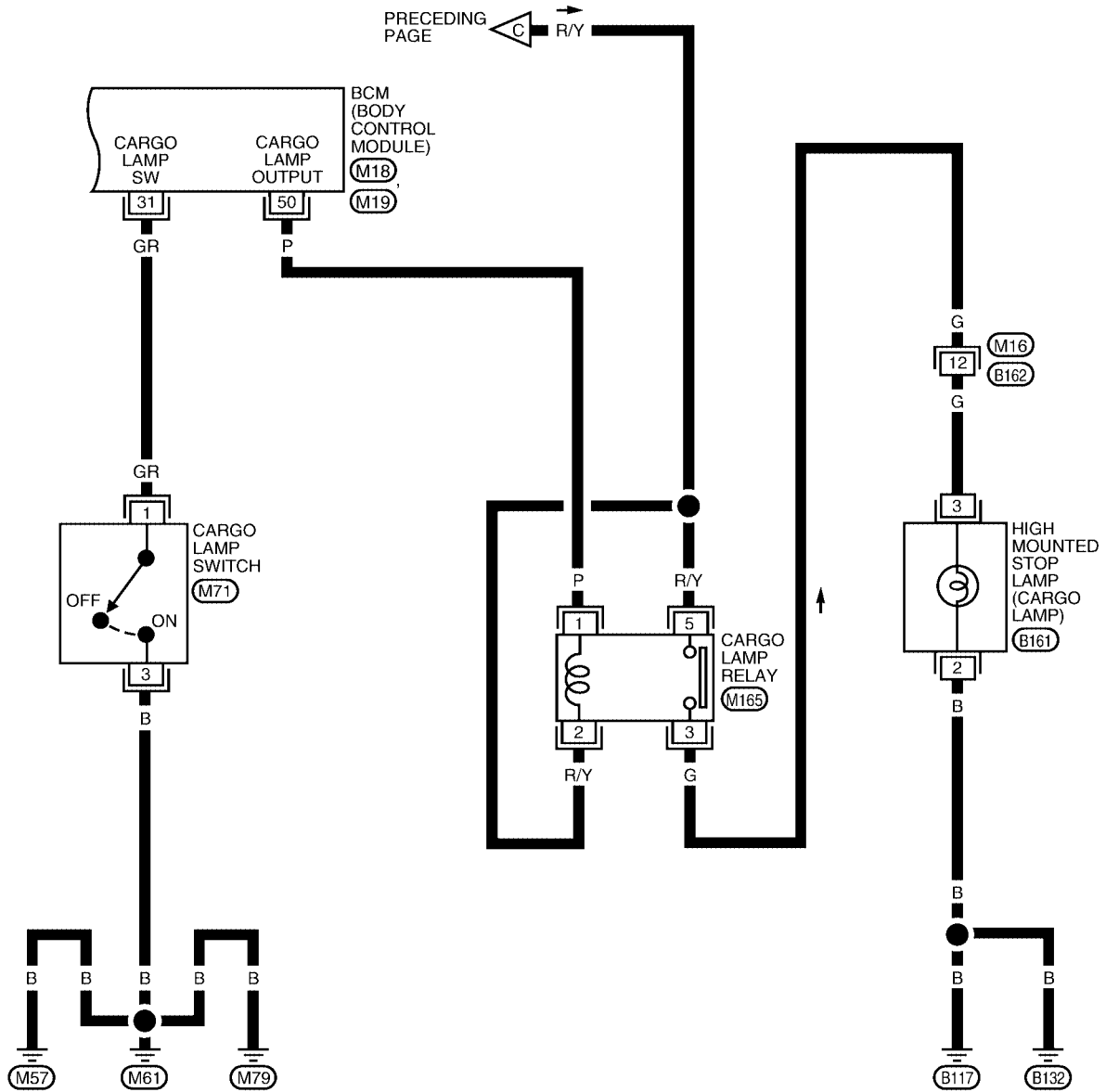

WKWA4379E

# INTERIOR ROOM LAMP

LT-INT/L-10

: WITH FRONT MAP LAMPS

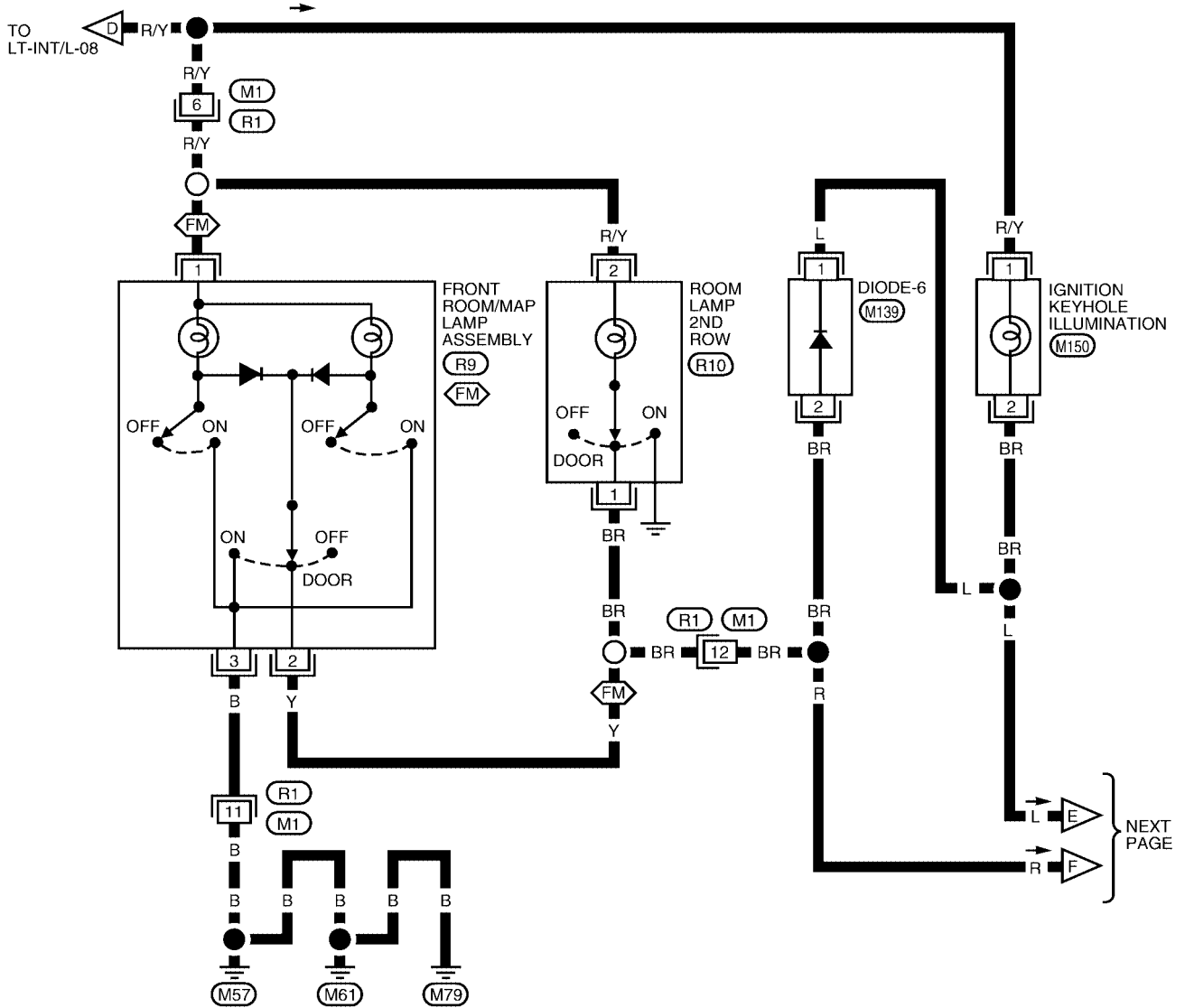

A  
B  
C  
D  
E  
F  
G  
H  
I  
J  
LT  
L  
M

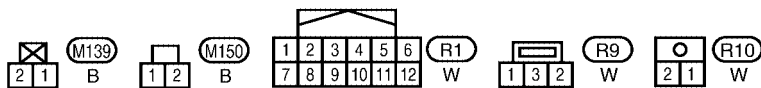

# INTERIOR ROOM LAMP

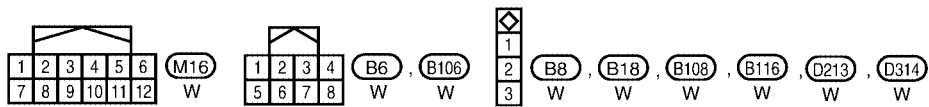
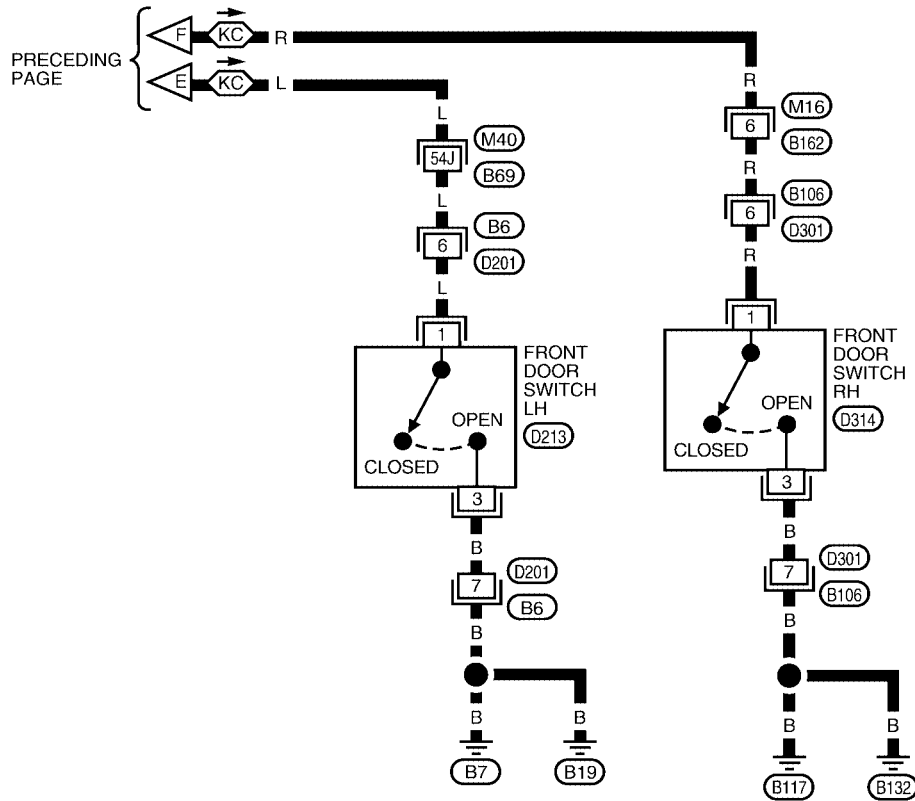
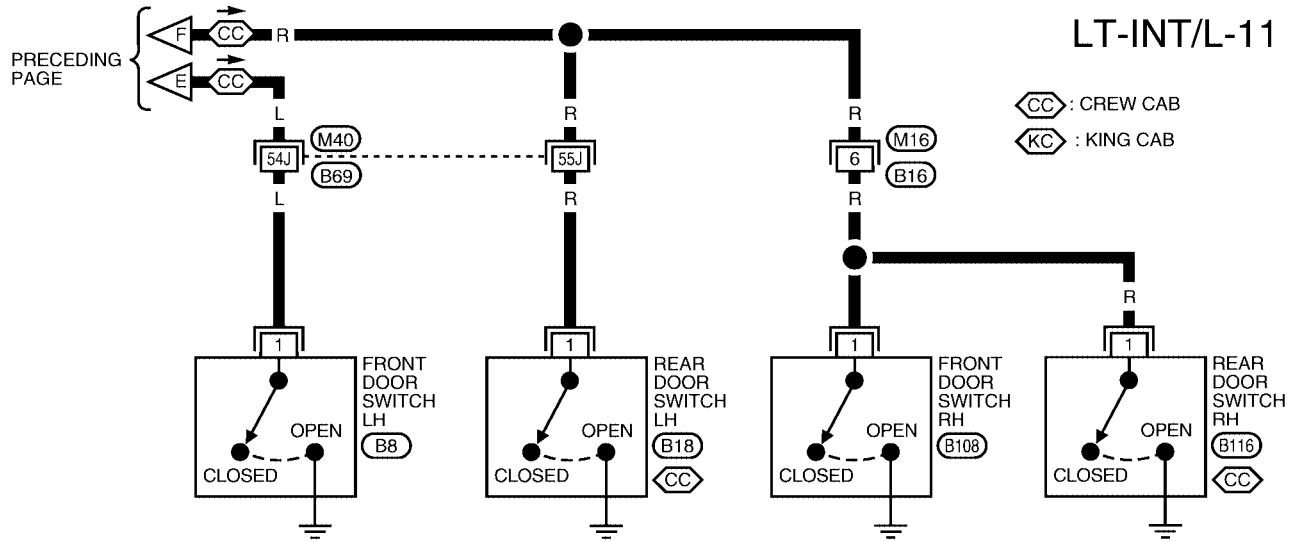

REFER TO THE FOLLOWING.  
M40 - SUPER MULTIPLE JUNCTION (SMJ)

WKWA4381E

# INTERIOR ROOM LAMP

## Terminals and Reference Values for BCM

EKS00CNG

Refer to [BCS-12, "Terminals and Reference Values for BCM"](#) .

## How to Proceed With Trouble Diagnosis

EKS00CNH

1. Confirm the symptom or customer complaint.
2. Understand operation description and function description. Refer to [LT-116, "System Description"](#) .
3. Carry out the Preliminary Check. Refer to [LT-135, "Preliminary Check"](#) .
4. Check symptom and repair or replace the cause of malfunction.
5. Does the interior room lamp operate normally? If YES: GO TO 6. If NO: GO TO 4.
6. Inspection End.

## Preliminary Check

EKS00CNI

### INSPECTION FOR POWER SUPPLY AND GROUND CIRCUIT

Refer to [BCS-16, "BCM Power Supply and Ground Circuit Check"](#) .

## CONSULT-II Function (BCM)

EKS00CNU

CONSULT-II can display each diagnostic item using the diagnostic test modes shown following.

BCM diagnostic test item	Diagnostic mode	Description
Inspection by part	WORK SUPPORT	Supports inspections and adjustments. Commands are transmitted to the BCM for setting the status suitable for required operation, input/output signals are received from the BCM and received data is displayed.
	DATA MONITOR	Displays BCM input/output data in real time.
	ACTIVE TEST	Operation of electrical loads can be checked by sending drive signal to them.
	SELF-DIAG RESULTS	Displays BCM self-diagnosis results.
	CAN DIAG SUPPORT MNTR	The result of transmit/receive diagnosis of CAN communication can be read.
	ECU PART NUMBER	BCM part number can be read.
	CONFIGURATION	Performs BCM configuration read/write functions.

## CONSULT-II OPERATION

### CAUTION:

If CONSULT-II is used with no connection of CONSULT-II CONVERTER, malfunctions might be detected in self-diagnosis depending on control unit which carries out CAN communication.

1. With the ignition switch OFF, connect CONSULT-II and CONSULT-II CONVERTER to the data link connector, then turn ignition switch ON.

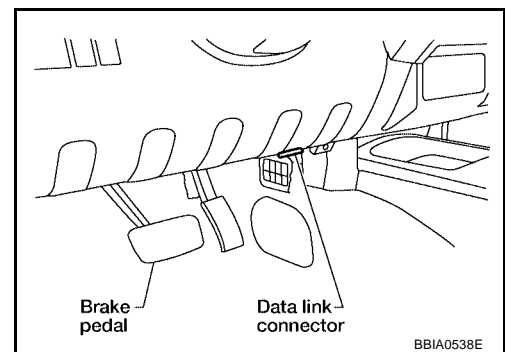

# INTERIOR ROOM LAMP

2. Touch "START (NISSAN BASED VHCL)".

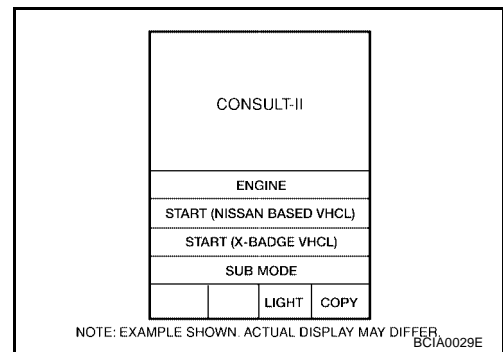

3. Touch "BCM" on "SELECT SYSTEM" screen.  
If "BCM" is not indicated, go to [GI-41, "CONSULT-II Data Link Connector \(DLC\) Circuit"](#).

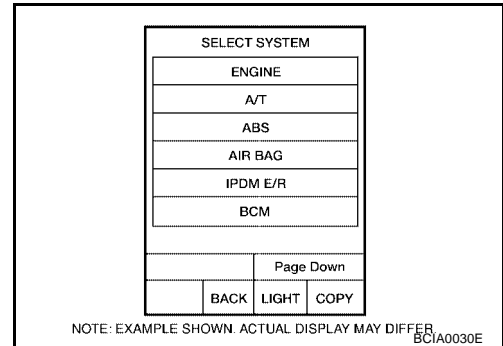

4. Touch "INT LAMP" on "SELECT TEST ITEM" screen.

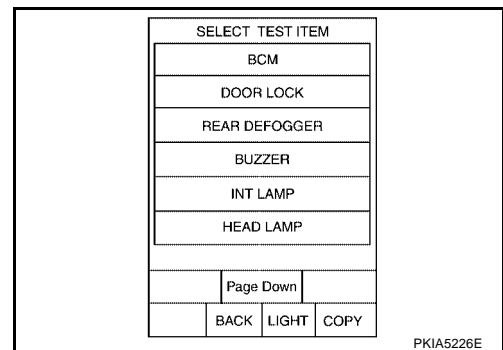

## WORK SUPPORT

### Operation Procedure

1. Touch "INT LAMP" on "SELECT TEST ITEM" screen.
2. Touch "WORK SUPPORT" on "SELECT DIAG MODE" screen.
3. Touch "SET I/L D-UNLCK INTCON" on "SELECT WORK ITEM" screen.
4. Touch "START".
5. Touch "CHANGE SETT".
6. The setting will be changed and "CUSTOMIZING COMPLETED" will be displayed.
7. Touch "END".



# INTERIOR ROOM LAMP

## Display Item List

Item	Description	CONSULT-II
SET I/L D-UNLCK INTCON	The 30 seconds operating function of the interior room lamps and the ignition keyhole illumination can be selected when driver door is released (unlocked).	ON/OFF
ROOM LAMP ON TIME SET	The time in order to escalate illumination can be adjusted when the interior room lamps and the ignition keyhole illumination is turned on.	MODE 1 - 7
ROOM LAMP OFF TIME SET	The time in order to diminish illumination can be adjusted when the interior room lamps and the ignition keyhole illumination is turned off.	MODE 1 - 7

Reference between "MODE" and "TIME" for "TURN ON/OFF".

MODE	1	2	3	4	5	6	7
Time (sec.)	0.5	1	2	3	4	5	0

## DATA MONITOR

### Operation Procedure

1. Touch "INT LAMP" on "SELECT TEST ITEM" screen.
2. Touch "DATA MONITOR" on "SELECT DIAG MODE" screen.
3. Touch either "ALL SIGNALS" or "SELECTION FROM MENU" on "SELECT MONITOR ITEM" screen.

ALL SIGNALS	Monitors all the signals.
SELECTION FROM MENU	Selects and monitors the individual signal.

4. Touch "START".
5. When "SELECTION FROM MENU" is selected, touch items to be monitored. When "ALL SIGNALS" is selected, all the items will be monitored.
6. Touch "RECORD" while monitoring, then the status of the monitored item can be recorded. To stop recording, touch "STOP".

## Display Item List

Monitor item	Contents
IGN ON SW	"ON/OFF" Displays "IGN position (ON)/OFF, ACC position (OFF)" judged from the ignition switch signal.
KEY ON SW	"ON/OFF" Displays "Key inserted (ON)/key removed (OFF)" status judged from the key switch signal.
DOOR SW-DR	"ON/OFF" Displays status of the driver door as judged from the driver door switch signal. (Door is open: ON/Door is closed: OFF)
DOOR SW-AS	"ON/OFF" Displays "Door open (ON)/Door closed (OFF)" status, determined from passenger door switch signal.
DOOR SW-RR	"ON/OFF" Displays "Door open (ON)/Door closed (OFF)" status, determined from rear door switch RH signal.
DOOR SW-RL	"ON/OFF" Displays "Door open (ON)/Door closed (OFF)" status, determined from rear door switch LH signal.
BACK DOOR SW	"ON/OFF" Displays "Door open (ON)/Door closed (OFF)" status, determined from back door switch signal.
KEY CYL LK-SW	"ON/OFF" Displays "Door locked (ON)" status, determined from key cylinder lock switch in driver door.
KEY CYL UN-SW	"ON/OFF" Displays "Door unlocked (OFF)" status, determined from key cylinder lock switch in driver door.
CDL LOCK SW	"ON/OFF" Displays "Door locked (ON)/Door unlocked (OFF)" status, determined from locking detection switch in driver door.
CDL UNLOCK SW	"ON/OFF" Displays "Door unlocked (OFF)" status, determined from locking detection switch in passenger door.

# INTERIOR ROOM LAMP

Monitor item	Contents
KEYLESS LOCK "ON/OFF"	Displays "Locked (ON)/Other (OFF)" status, determined from lock signal.
KEYLESS UNLOCK "ON/OFF"	Displays "Unlocked (ON)/Other (OFF)" status, determined from unlock signal.

## ACTIVE TEST

### Operation Procedure

1. Touch "INT LAMP" on "SELECT TEST ITEM" screen.
2. Touch "ACTIVE TEST" on "SELECT DIAG MODE" screen.
3. Touch item to be tested and check operation of the selected item.
4. During the operation check, touching "BACK" or "OFF" deactivates the operation.

### Display Item List

Test item	Description
INT LAMP	Interior room lamp can be operated by any ON-OFF operations.
IGN ILLUM	Ignition keyhole illumination can be operated by ON-OFF operation.

## Room/Map Lamp Does Not Turn ON or OFF Properly MODELS WITHOUT POWER DOOR LOCKS

EKS00D76

### 1. CHECK FRONT ROOM/MAP LAMP AND ROOM LAMP 2ND ROW FUSE

Check 10A fuse [No. 18, located in fuse block (J/B)].

#### OK or NG

- OK >> GO TO 2.
- NG >> Replace fuse. Check harness for short between fuse and front room/map lamp (with map lamp) or room lamp 2nd row.

### 2. CHECK FRONT ROOM/MAP LAMP AND ROOM 2ND ROW LAMP SWITCH SIGNALS

1. Close all doors, turn ON front room/map lamp and room lamp 2nd row switches.

**Front room/map lamp and room lamp 2nd row should turn on.**

2. Turn OFF front room/map lamp and room lamp 2nd row switches.

**Front room/map lamp and room lamp 2nd row should turn off.**

#### OK or NG

- OK >> GO TO 3.
- NG >> Check the following.
  - Front room/map lamp and room lamp 2nd row switch
  - Front room/map lamp and room lamp 2nd row ground circuits
  - Harness for open or short between front room/map lamp, room lamp 2nd row switches and front door switch LH, front door switch RH, rear door switch LH or rear door switch RH

### 3. CHECK FRONT ROOM/MAP LAMP AND ROOM LAMP 2ND ROW POWER SUPPLY

Check voltage between front room/map lamp connector R9 terminal 1, room lamp 2nd row connector R10 terminal 2 and ground.

#### OK or NG

- OK >> GO TO 4.
- NG >> Check harness for open between fuse and front room/map lamp or room lamp 2nd row.

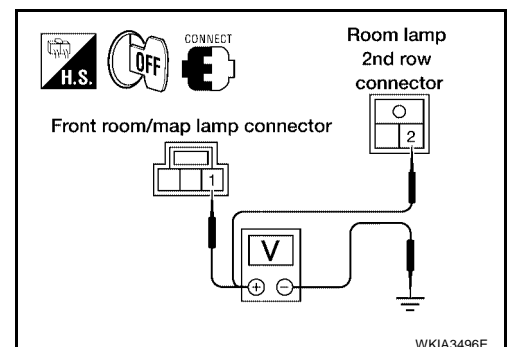

# INTERIOR ROOM LAMP

## 4. CHECK INTERIOR ROOM LAMP BULB

Check interior room lamp bulb.

OK or NG

- OK >> GO TO 5.
- NG >> Replace bulb.

## 5. CHECK KEY SWITCH (INSERTED) AND IGNITION ON SIGNAL

1. Insert key into ignition key cylinder.
2. Open front door LH.

**Warning chime should sound.**

3. Turn ignition key to ON position.

**Warning chime should stop sounding.**

OK or NG

- OK >> Check harness for open or short between front room/map lamp, room lamp 2nd row switches and front door switch LH, front door switch RH, rear door switch LH or rear door switch RH.
- NG >> Refer to [DI-50, "WARNING CHIME"](#) .

## Room/Map Lamp Control Does Not Operate MODELS WITH POWER DOOR LOCKS

EKS00CNK

### 1. CHECK EACH SWITCH

Select "BCM" on CONSULT-II. With "INT LAMP" data monitor, make sure switches listed in display item list turn ON-OFF linked with switch operation. Refer to [LT-137, "Display Item List"](#) for switches and their functions.

OK or NG

- OK >> GO TO 2.
- NG >> Inspect malfunctioning switch system.

DATA MONITOR	
MONITOR	
IGN ON SW	ON
KEY ON SW	ON
DOOR SW-DR	ON
DOOR SW-AS	ON
DOOR SW-RR	OFF
DOOR SW-RL	OFF
BACK DOOR SW	OFF
KEY CYL LK-SW	OFF
KEY CYL UN-SW	OFF

SKIA5930E

### 2. ACTIVE TEST

1. Select "BCM" on CONSULT-II. Select "INT LAMP" active test.
2. When switch is in "DOOR" position, use active test to make sure interior room lamp operates.

**Room lamps should turn on.**

OK or NG

- OK >> Replace BCM. Refer to [BCS-26, "Removal and Installation"](#) .
- NG >> GO TO 3.

ACTIVE TEST	
INT LAMP	ON
	OFF

LKIA0092E

# INTERIOR ROOM LAMP

## 3. CHECK INTERIOR ROOM LAMP INPUT

1. Turn ignition switch OFF.
2. Check voltage between front room/map lamp assembly harness connector R9 terminal 1 and ground.

**1 - Ground** : Battery voltage should exist.

OK or NG

- OK >> GO TO 4.  
NG >> GO TO 5.

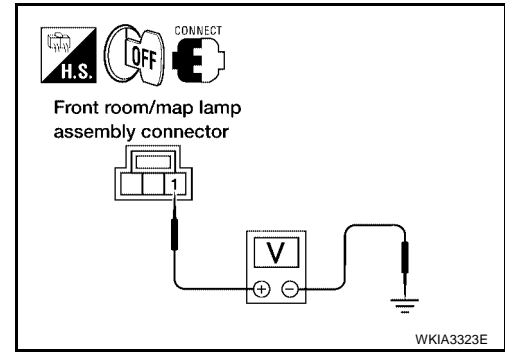

## 4. CHECK INTERIOR ROOM LAMP CIRCUIT

1. Disconnect BCM connector.
2. Check continuity between BCM harness connector M20 terminal 63 and front room/map lamp assembly harness connector R9 terminal 2.

**63 - 2** : Continuity should exist.

OK or NG

- OK >> Replace BCM if interior lamp does not work after setting the connector again. Refer to [BCS-26, "Removal and Installation"](#).
- NG >> Repair harness or connector.

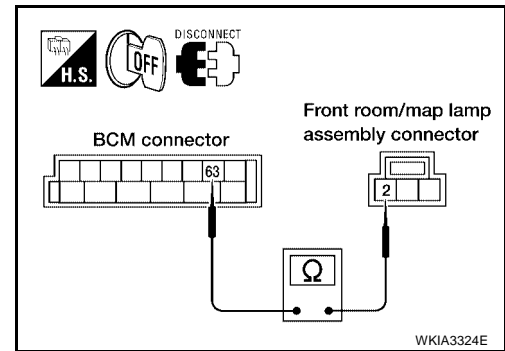

## 5. CHECK INTERIOR ROOM LAMP CIRCUIT

1. Disconnect BCM connector and front room/map lamp assembly connector.
2. Check continuity between BCM harness connector M20 terminal 56 and front room/map lamp assembly harness connector R9 terminal 1.

**56 - 1** : Continuity should exist.

OK or NG

- OK >> Replace BCM if interior lamp does not work after setting the connector again. Refer to [BCS-26, "Removal and Installation"](#).
- NG >> Repair harness or connector between BCM and room/map lamp.

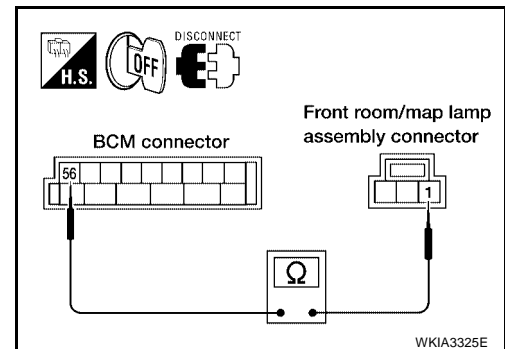

# INTERIOR ROOM LAMP

EKS00D77

## Room Lamp 2nd Row Control Does Not Operate

### 1. CHECK EACH DOOR SWITCH

Select "BCM" on CONSULT-II. With "INT LAMP" data monitor, make sure switches listed in display item list turn ON-OFF linked with switch operation. Refer to [LT-116, "Switch Operation"](#) (models without power door locks) or [LT-118, "Switch Operation"](#) (models with power door locks) for switches and their function.

#### OK or NG

- OK >> GO TO 2.
- NG >> Inspect malfunctioning door switch.

DATA MONITOR	
MONITOR	
IGN ON SW	ON
KEY ON SW	ON
DOOR SW-DR	ON
DOOR SW-AS	ON
DOOR SW-RR	OFF
DOOR SW-RL	OFF
BACK DOOR SW	OFF
KEY CYL LK-SW	OFF
KEY CYL UN-SW	OFF

SKIA5930E

### 2. CHECK ROOM LAMP 2ND ROW OUTPUT

1. Turn ignition switch OFF.
2. Confirm lamp switch is in the "DOOR" position.
3. Disconnect room lamp 2nd row connector.
4. Open any door.
5. Check voltage between room lamp 2nd row harness connector R10 terminal 2 and ground.

**2 - Ground : Battery voltage should exist.**

#### OK or NG

- OK >> GO TO 3.
- NG >> Repair harness or connector.

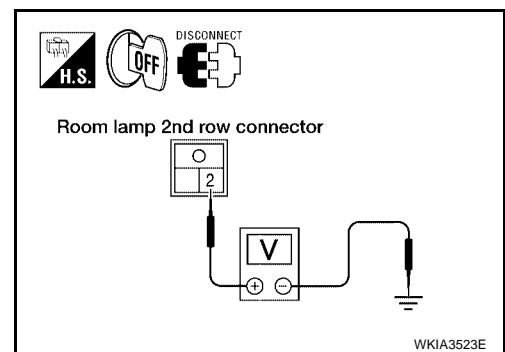

### 3. CHECK ROOM LAMP 2ND ROW CONTROL CIRCUIT

1. Disconnect BCM connector M20.
2. Check continuity between BCM harness connector M20 terminal 63 and room lamp 2nd row harness connector R10 terminal 1.

**63 - 1 : Continuity should exist.**

#### OK or NG

- OK >> Replace room lamp 2nd row.
- NG >> Repair harness or connector.

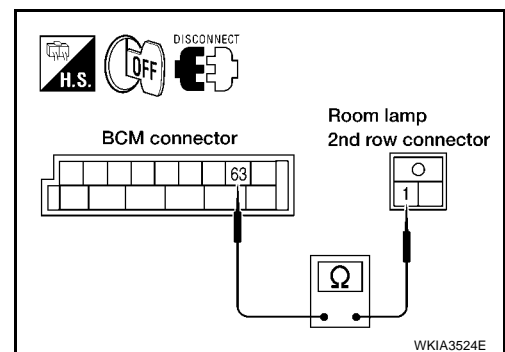

A  
B  
C  
D  
E  
F  
G  
H  
I  
J  
LT  
L  
M

# INTERIOR ROOM LAMP

## All Interior Room Lamps Do Not Operate MODELS WITH POWER DOOR LOCKS

EKS00GNM

### 1. CHECK POWER SUPPLY CIRCUIT

1. All interior room lamp switches are OFF.
2. Turn ignition switch ON.
3. Check voltage between BCM harness connector M20 terminal 56 and ground.

**56 - Ground : Battery voltage should exist.**

#### OK or NG

- OK >> Repair harness or connector. To prevent making a short circuit, be sure to disconnect battery negative cable after repairing harness, and then reconnect.
- NG >> Replace BCM. Refer to [BCS-26, "Removal and Installation"](#).

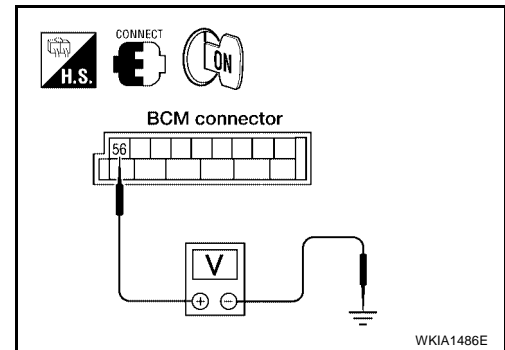

## ILLUMINATION

### Component Parts and Harness Connector Location

EKS00HMA

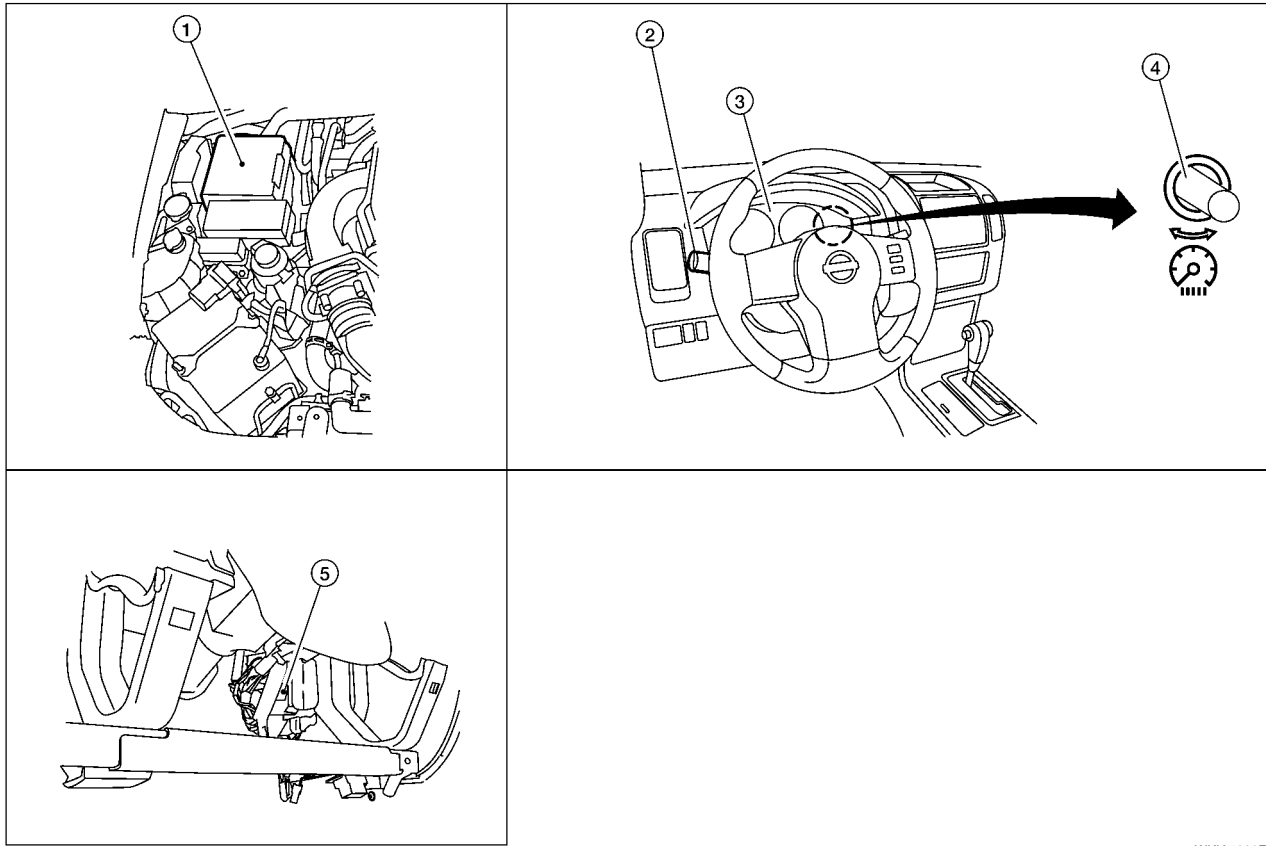

WKIA5029E

- |  |   |                             |
|--|---|-----------------------------|
| 1. IPDM E/R<br>E122, E123, E124                                  | 2. Combination switch (lighting switch)<br>M28                      | 3. Combination meter<br>M24 |
| 4. Illumination control switch<br>(built into combination meter) | 5. BCM<br>M18, M20<br>(view with instrument lower panel LH removed) |                             |

### System Description

EKS00CNN

Control of the illumination lamps operation is dependent upon the position of the lighting switch (combination switch). When the lighting switch is placed in the 1ST or 2ND position (or if the auto light system is activated) the BCM (body control module) receives input signal requesting the illumination lamps to illuminate. This input signal is communicated to the IPDM E/R (intelligent power distribution module engine room) across the CAN communication lines. The CPU (central processing unit) of the IPDM E/R controls the tail lamp relay coil. This relay, when energized, directs power to the illumination lamps, which then illuminate. Power is supplied at all times

- to ignition relay, located in the IPDM E/R, and
- to tail lamp relay, located in the IPDM E/R, and
- through 50A fusible link (letter **g**, located in the fuse and fusible link box)
- to BCM terminal 70, and
- through 20A fuse (No. 53, located in the IPDM E/R)
- to CPU of the IPDM E/R, and
- through 10A fuse [No.19, located in the fuse block (J/B)]
- to combination meter terminal 3.

With the ignition switch in the ON or START position, power is supplied

- to ignition relay, located in the IPDM E/R, and
- through 10A fuse [No. 1, located in the fuse block (J/B)]
- to BCM terminal 38.

A  
B  
C  
D  
E  
F  
G  
H  
I  
J  
LT

# ILLUMINATION

---

Ground is supplied

- to BCM terminal 67 and
- to combination meter terminals 13 and 23
- through grounds M57, M61 and M79, and
- to IPDM E/R terminals 38 and 59
- through grounds E9, E15 (all) and E24 (VQ40DE engine only).

## ILLUMINATION OPERATION BY LIGHTING SWITCH

With the lighting switch in the 1ST or 2ND position (or if the auto light system is activated), the BCM receives input signal requesting the illumination lamps to illuminate. This input signal is communicated to the IPDM E/R across the CAN communication lines. The CPU of the IPDM E/R controls the tail lamp relay coil, which, when energized, directs power

- through 10A fuse (No. 37, located in the IPDM E/R)
- through IPDM E/R terminal 57
- to door mirror remote control switch terminal 16 (with power outside mirrors)
- to hazard switch terminal 3
- to audio unit terminal 8 (with audio unit)
- to 4WD shift switch terminal 7 (with 4-wheel drive)
- to front air control terminal 8
- to clutch interlock cancel switch terminal 5 (with clutch interlock cancel switch)
- to cargo lamp switch terminal 4
- to differential lock switch terminal 4 (with electronic locking rear differential)
- to electric brake (pre-wiring) terminal 4
- to A/T device terminal 3 (with A/T)
- to front heated seat switch LH and RH terminal 5 (with heated seats)
- to VDC OFF switch terminal 3 (with VDC)
- to HDC switch terminal 5 (with VDC).

Illumination is controlled

- through combination meter terminal 22
- to door mirror remote control switch terminal 15 (with power outside mirrors)
- to hazard switch terminal 4
- to audio unit terminal 7 (with audio unit)
- to 4WD switch terminal 8 (with 4-wheel drive)
- to front air control terminal 9
- to clutch interlock cancel switch terminal 6 (with clutch interlock cancel switch)
- to cargo lamp switch terminal 2
- to differential lock switch terminal 5 (with electronic locking rear differential)
- to A/T device terminal 5 (with A/T)
- to front heated seat switch LH and RH terminal 6 (with heated seats)
- to VDC OFF switch terminal 4 (with VDC)
- to HDC switch terminal 6 (with VDC).

Ground is supplied

- to electric brake (pre-wiring) terminal 1
- through grounds M57, M61 and M79.

With power and ground supplied, illumination lamps illuminate.

## EXTERIOR LAMP BATTERY SAVER CONTROL

When the combination switch (lighting switch) is in the 1ST or 2ND position (or if auto light system is activated), and the ignition switch is turned from ON or ACC to OFF, the battery saver control function is activated. Under this condition, the illumination lamps remain illuminated for 5 minutes, then the illumination lamps are turned off.



# ILLUMINATION

When the lighting switch is turned from OFF to 1ST or 2ND position (or if auto light system is activated) after illumination lamps are turned off by the battery saver control, the illumination lamps illuminate again. Exterior lamp battery saver control mode can be changed by the function setting of CONSULT-II.

## CAN Communication System Description

EKS00BS6

Refer to [LAN-22, "CAN COMMUNICATION"](#) .

A

B

C

D

E

F

G

H

I

J

LT

L

M

# ILLUMINATION

## Schematic

EKS00BS7

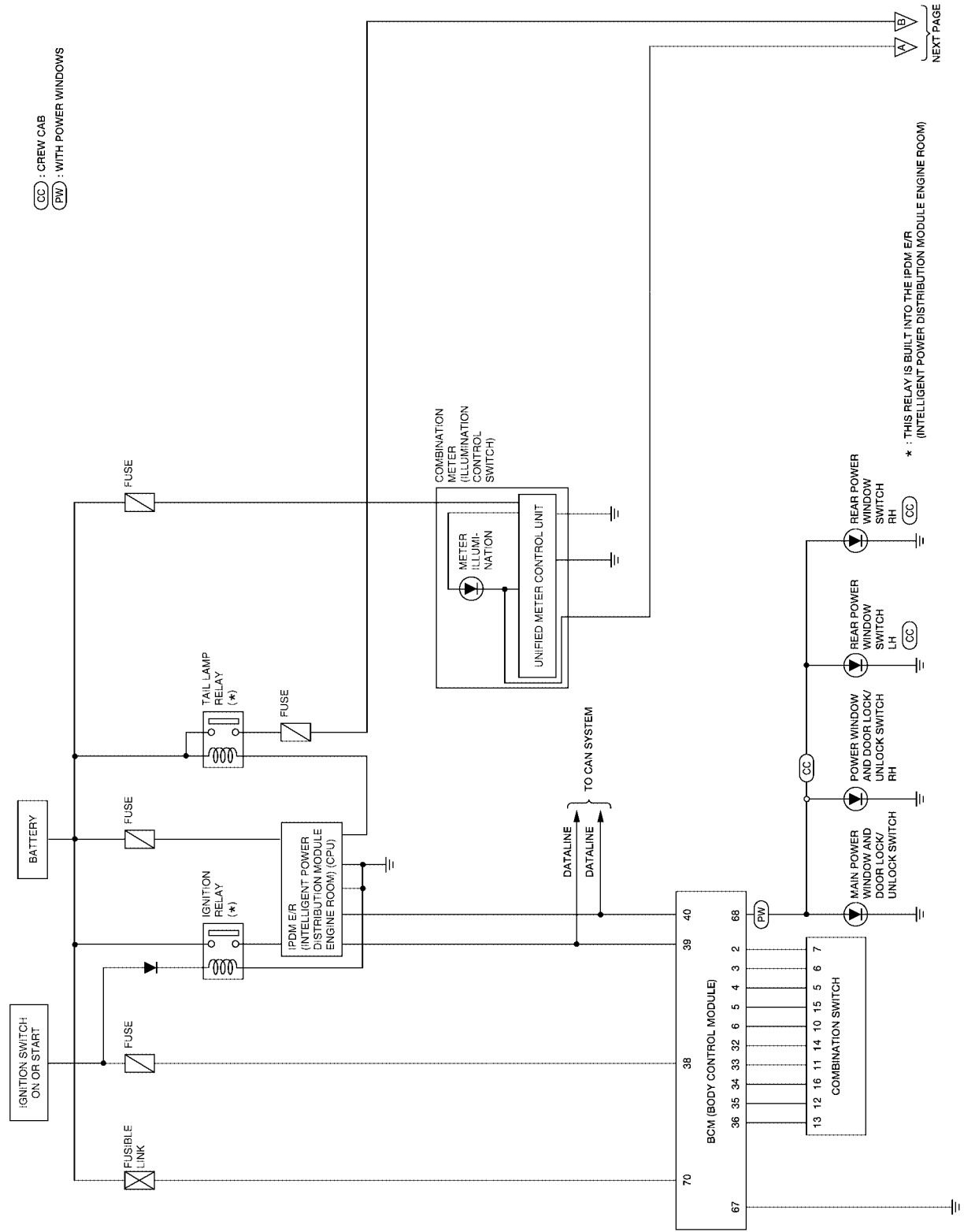

CC : CREW CAB  
PW : WITH POWER WINDOWS

\* : THIS RELAY IS BUILT INTO THE IPDM E/R (INTELLIGENT POWER DISTRIBUTION MODULE ENGINE ROOM)

NEXT PAGE

# ILLUMINATION

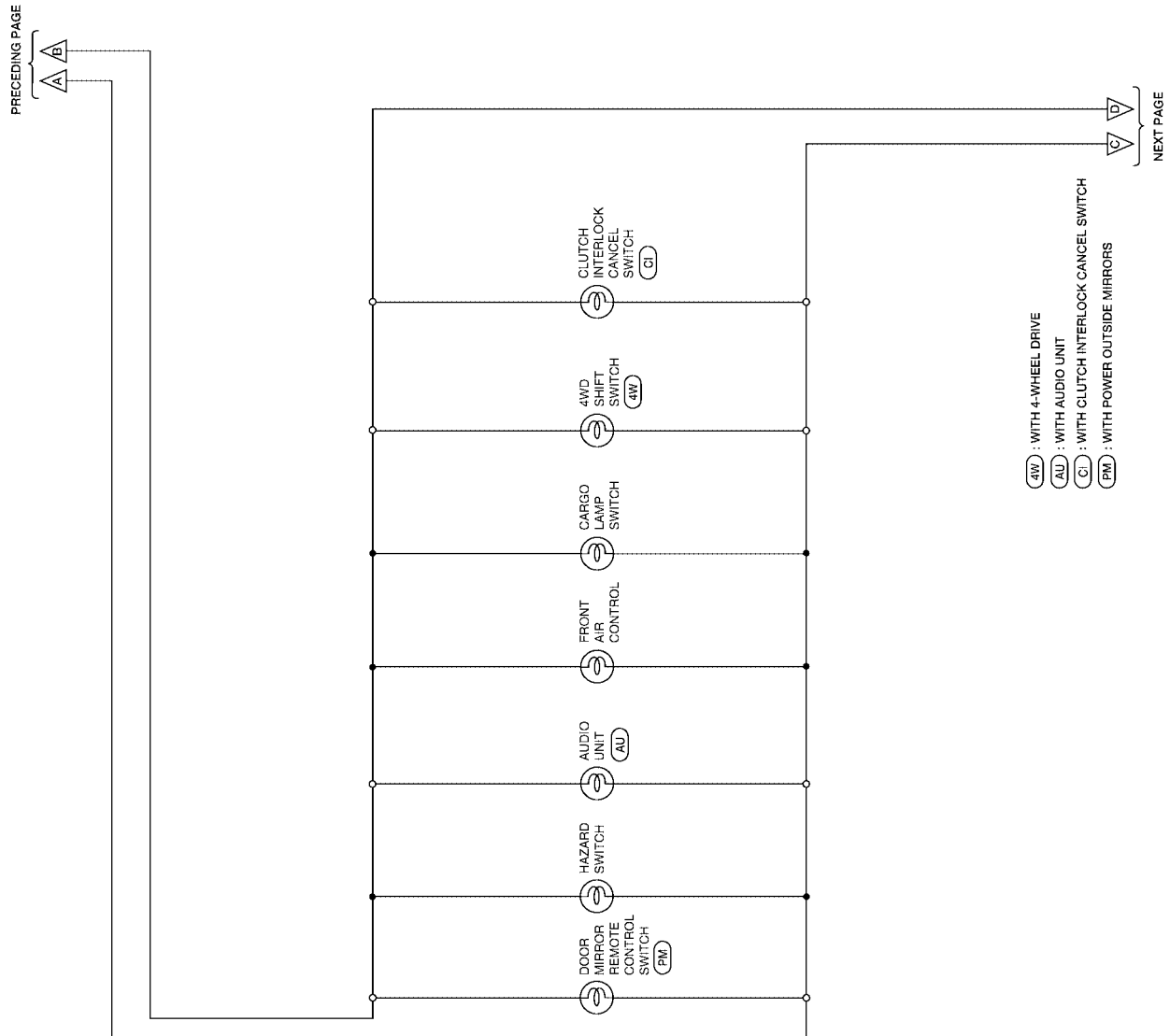

A  
 B  
 C  
 D  
 E  
 F  
 G  
 H  
 I  
 J  
 LT  
 L  
 M

# ILLUMINATION

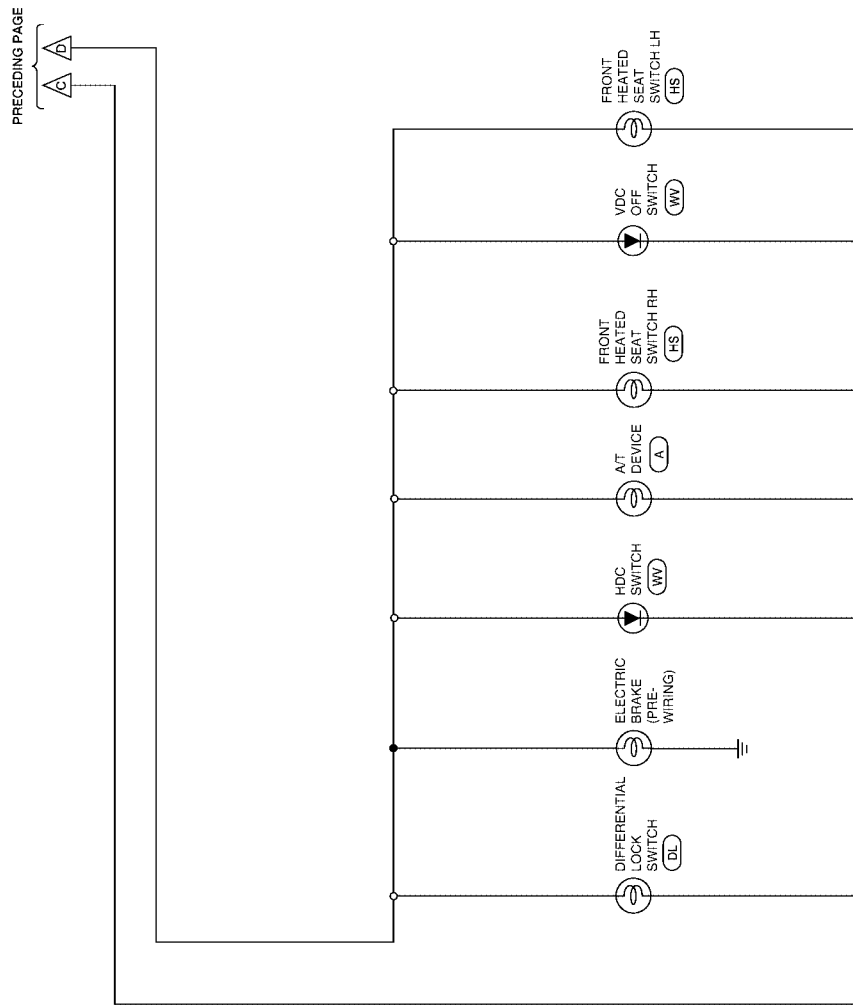

- (HS) : WITH HEATED SEATS
- (DL) : WITH ELECTRONIC LOCKING REAR DIFFERENTIAL
- (A) : WITH A/T
- (WV) : WITH VDC

WKWA4383E

# ILLUMINATION

## Wiring Diagram — ILL —

EKS00BS8

LT-ILL-01

▬ : DATA LINE

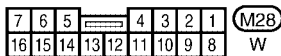
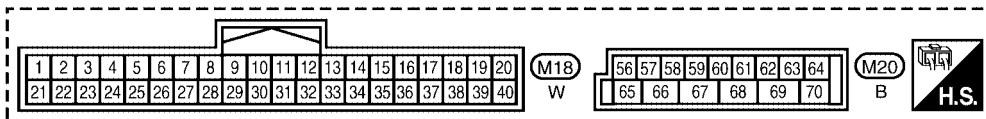
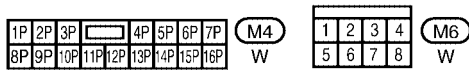
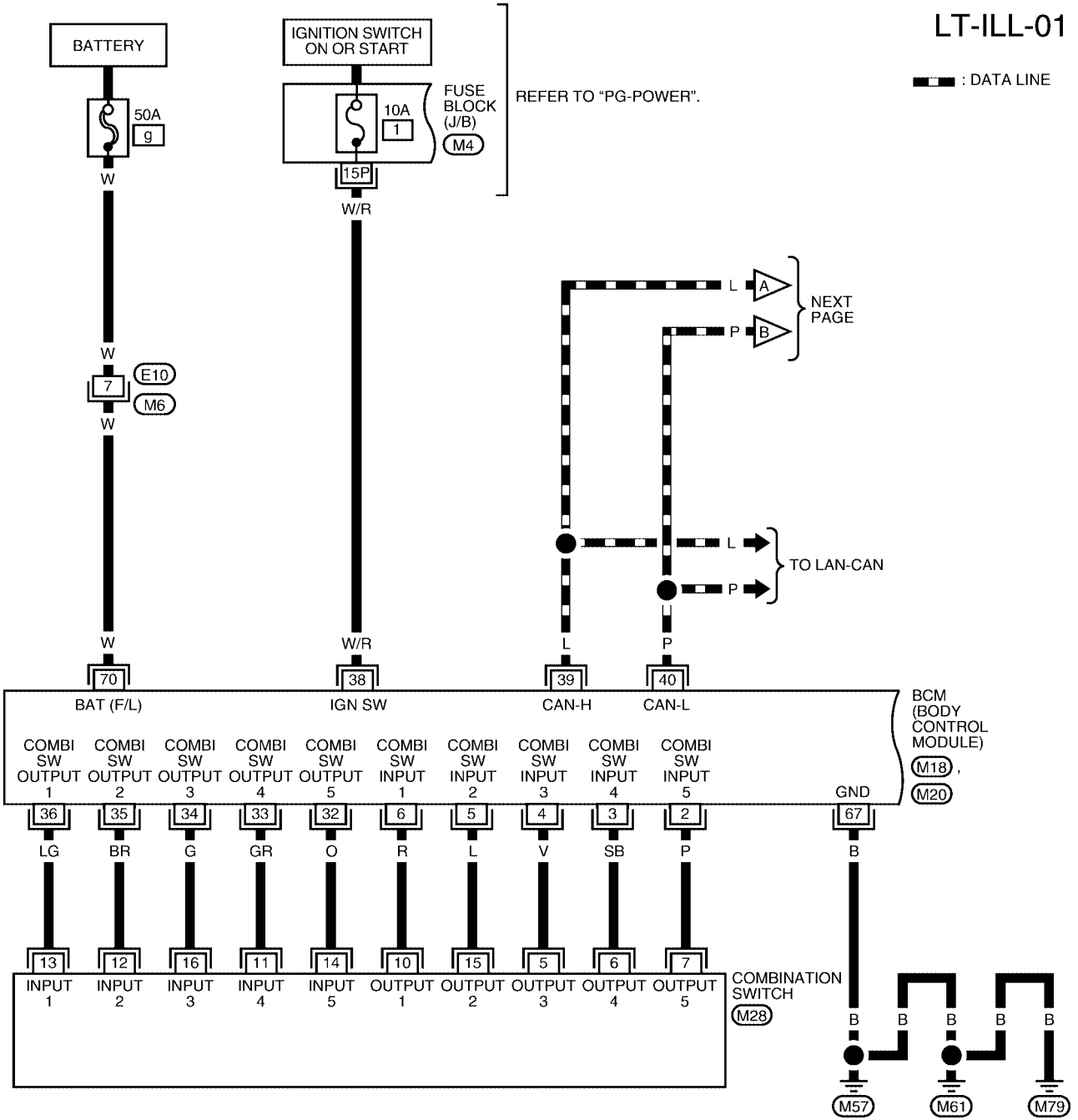

WKWA4384E

# ILLUMINATION

LT-ILL-02

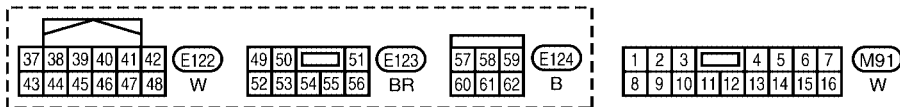
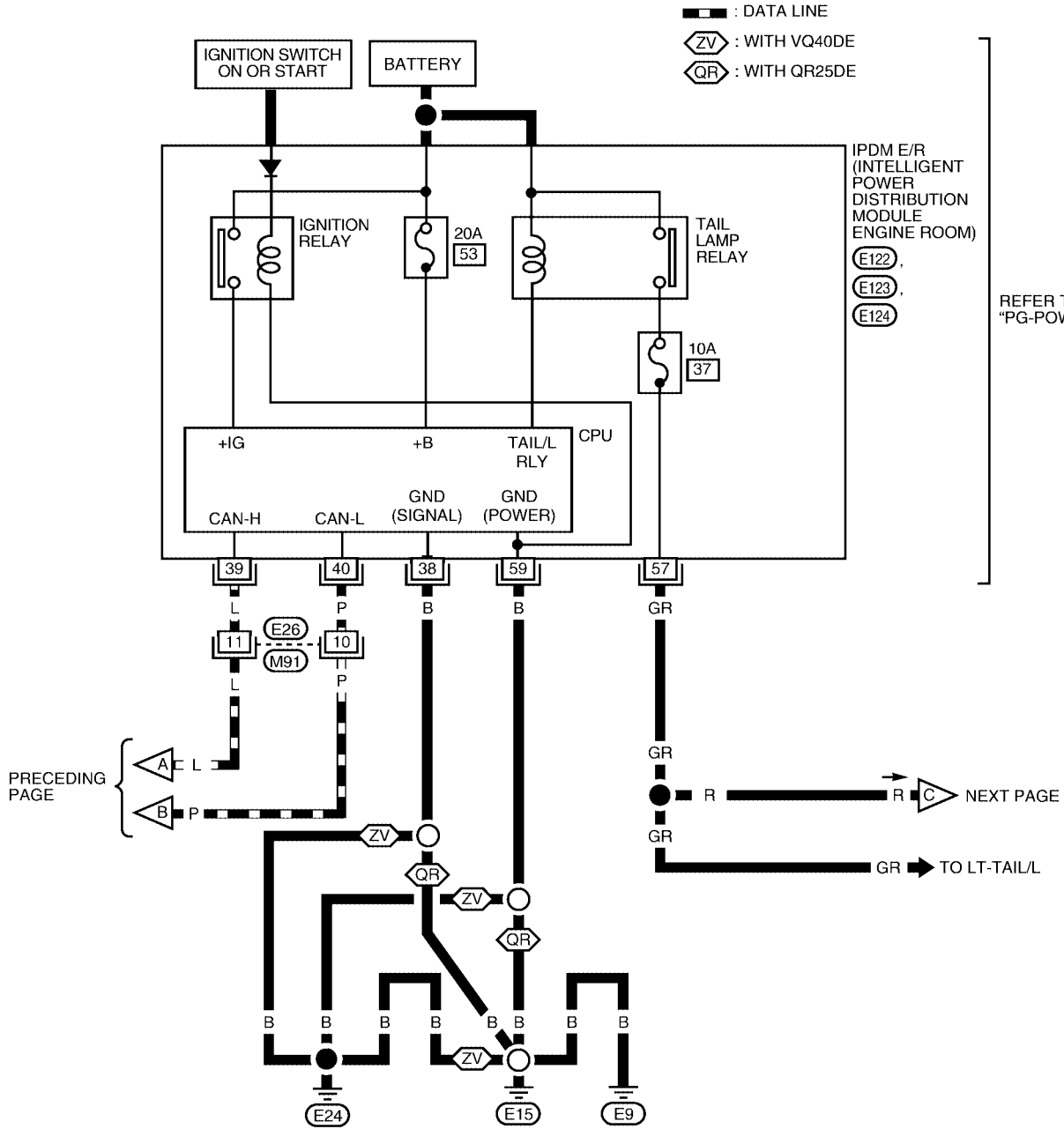

WKWA4385E

# ILLUMINATION

LT-ILL-03

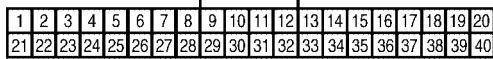
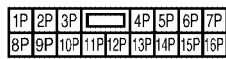
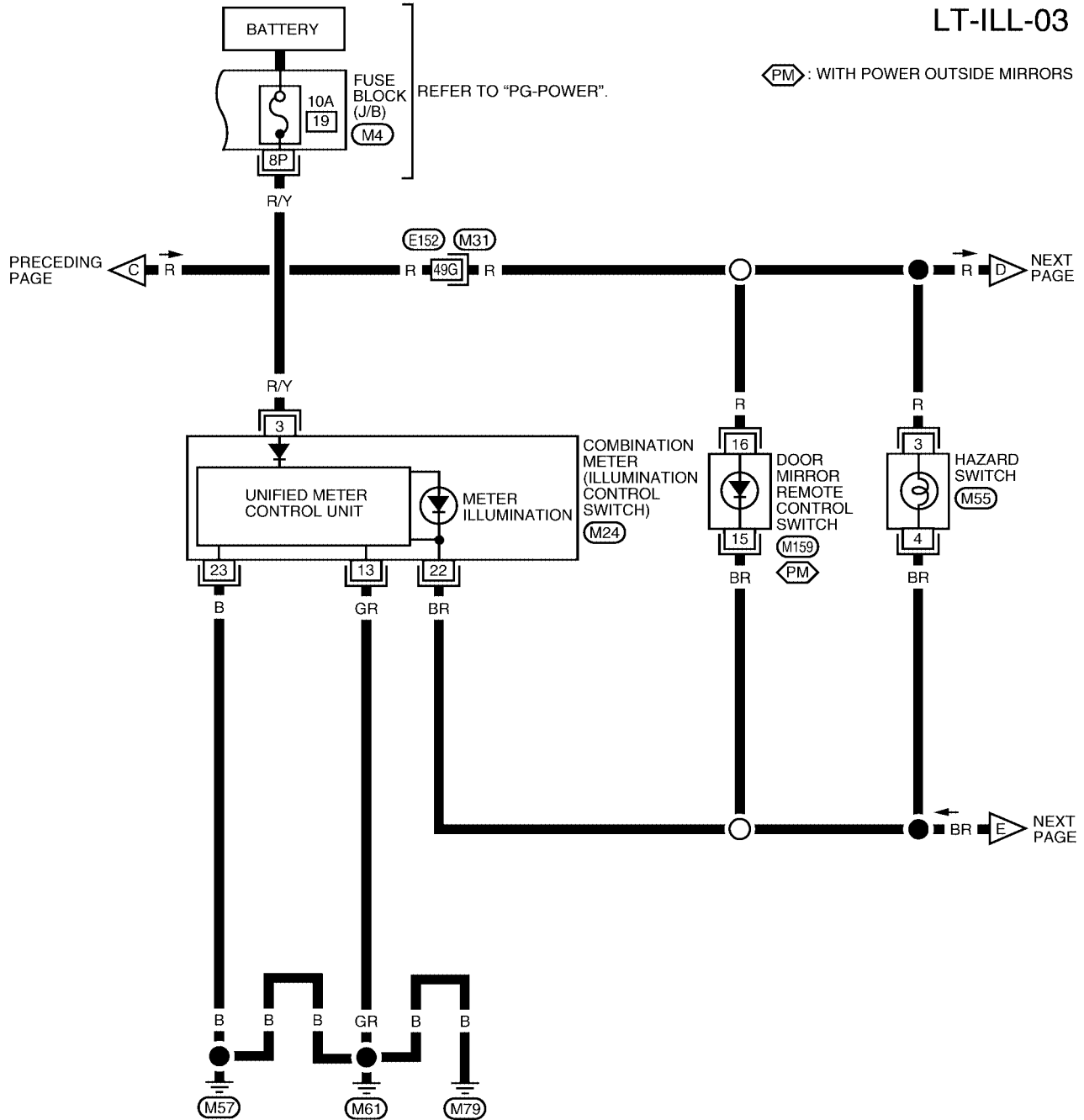

REFER TO THE FOLLOWING.  
 (M31) - SUPER MULTIPLE JUNCTION (SMJ)

WKWA4386E

# ILLUMINATION

LT-ILL-04

◀4W▶ : WITH 4-WHEEL DRIVE

◀AU▶ : WITH AUDIO UNIT

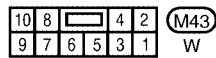
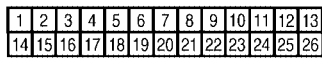
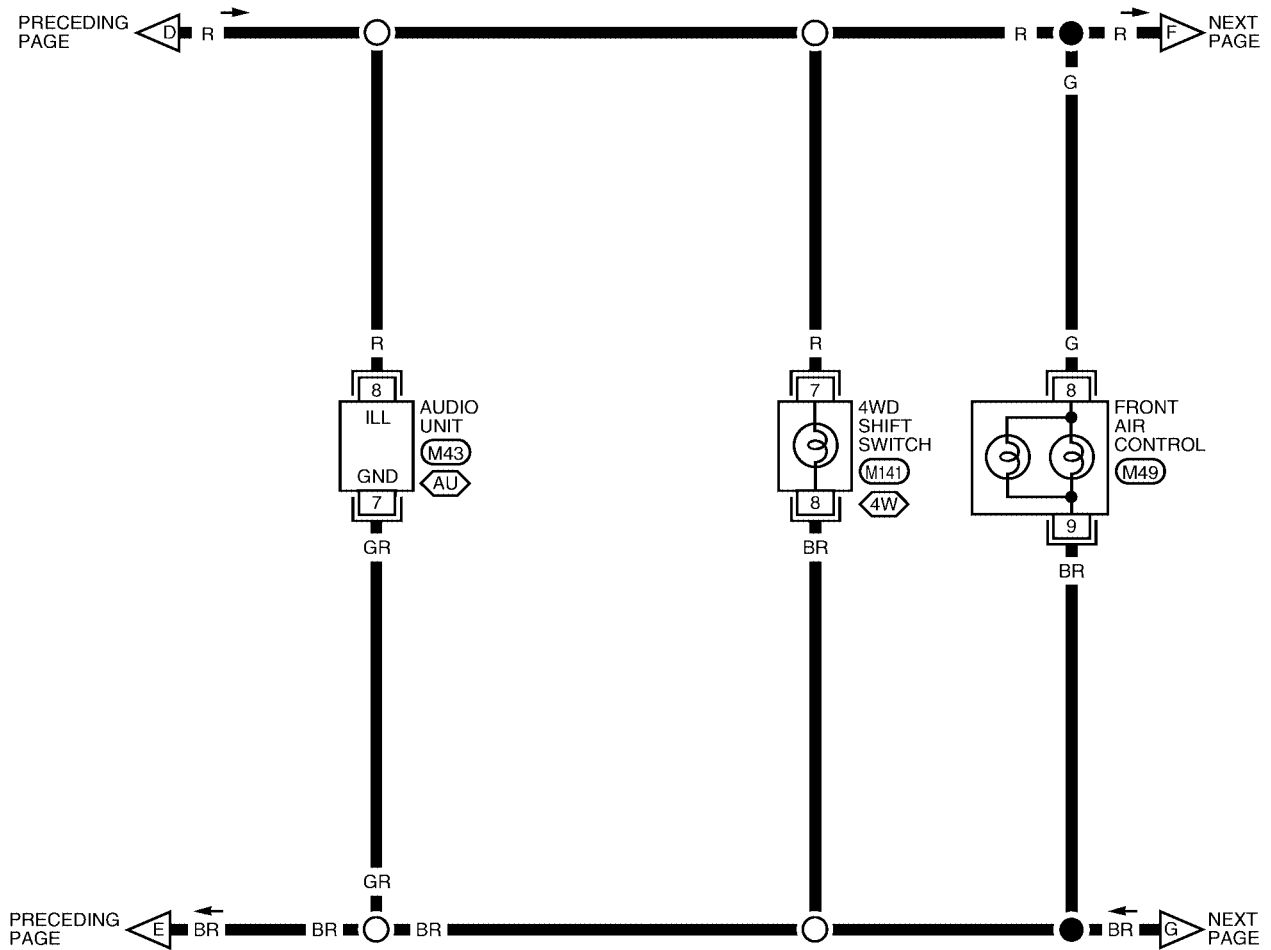

WKWA2862E



# ILLUMINATION

LT-ILL-05

 : WITH CLUTCH INTERLOCK CANCEL SWITCH

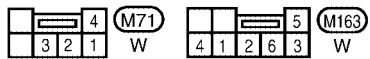
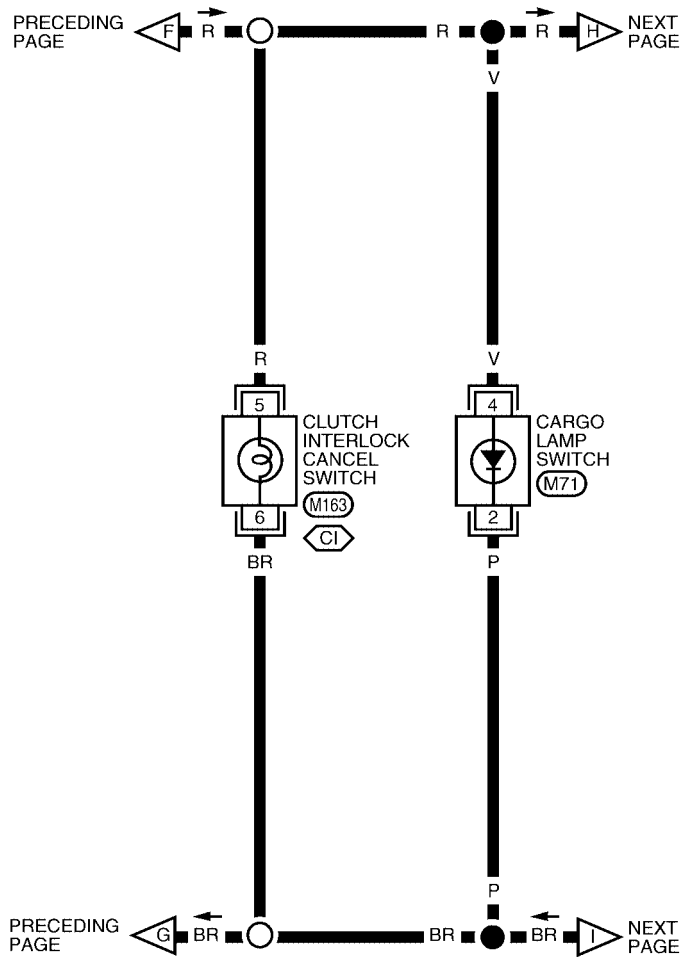

WKWA2863E

# ILLUMINATION

LT-ILL-06

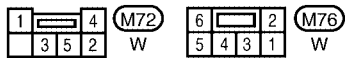
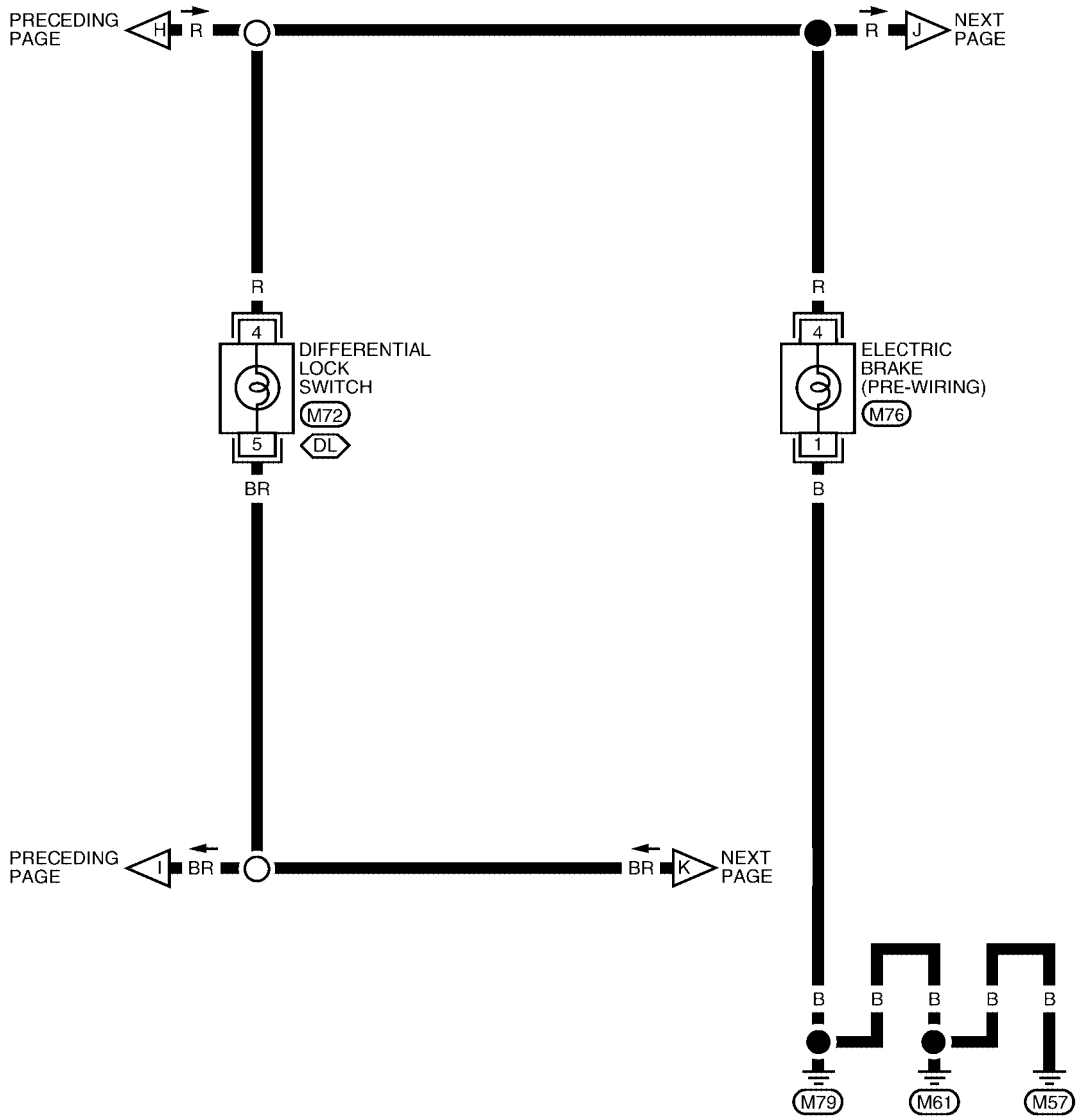

 : WITH ELECTRONIC LOCKING REAR DIFFERENTIAL



WKWA4488E

# ILLUMINATION

LT-ILL-07

-  : WITH A/T
-  : WITH HEATED SEATS
-  : WITH VDC

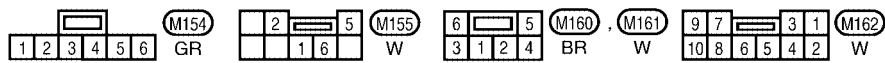
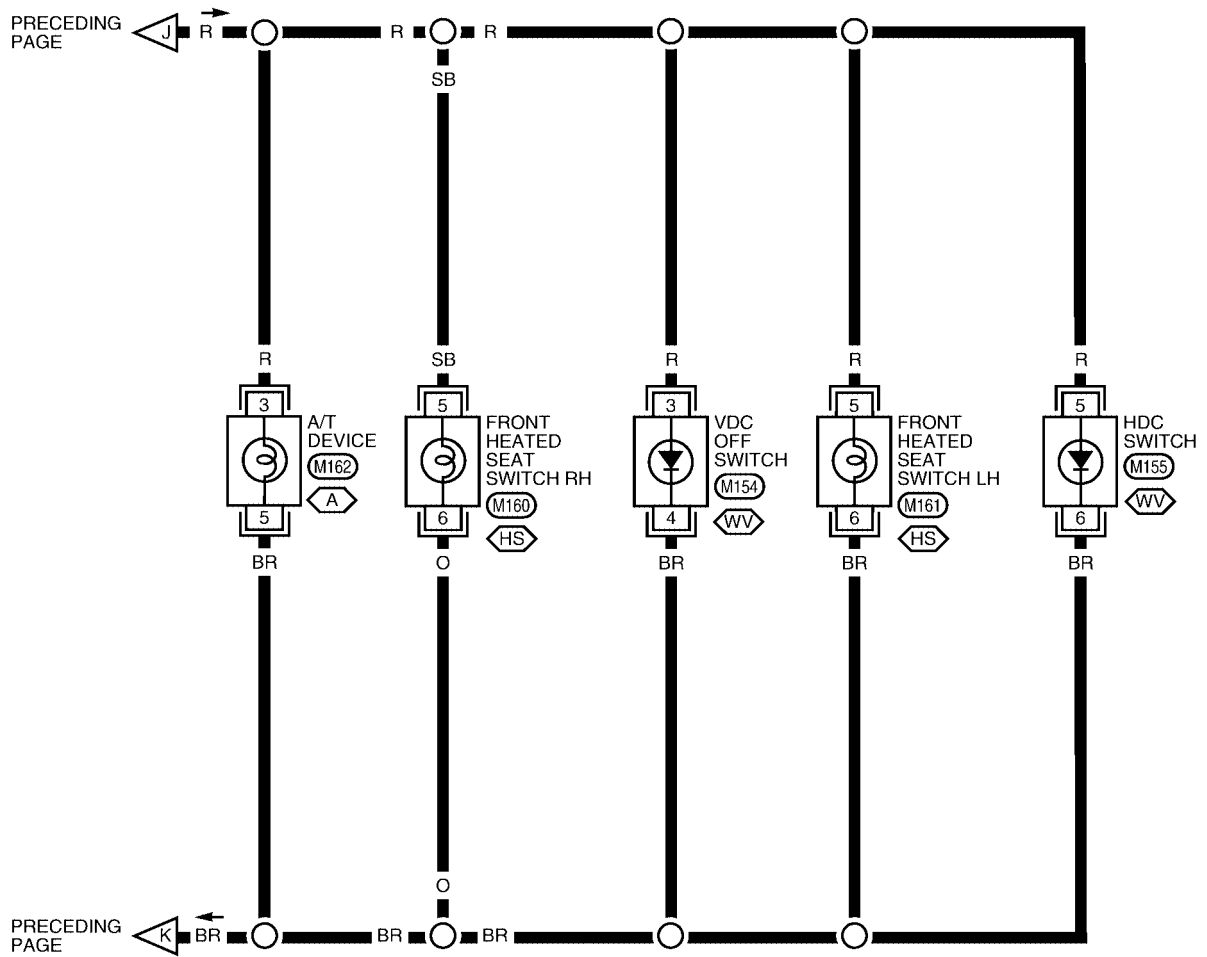

A  
B  
C  
D  
E  
F  
G  
H  
I  
J  
LT  
L  
M

WKWA4387E

# ILLUMINATION

LT-ILL-08

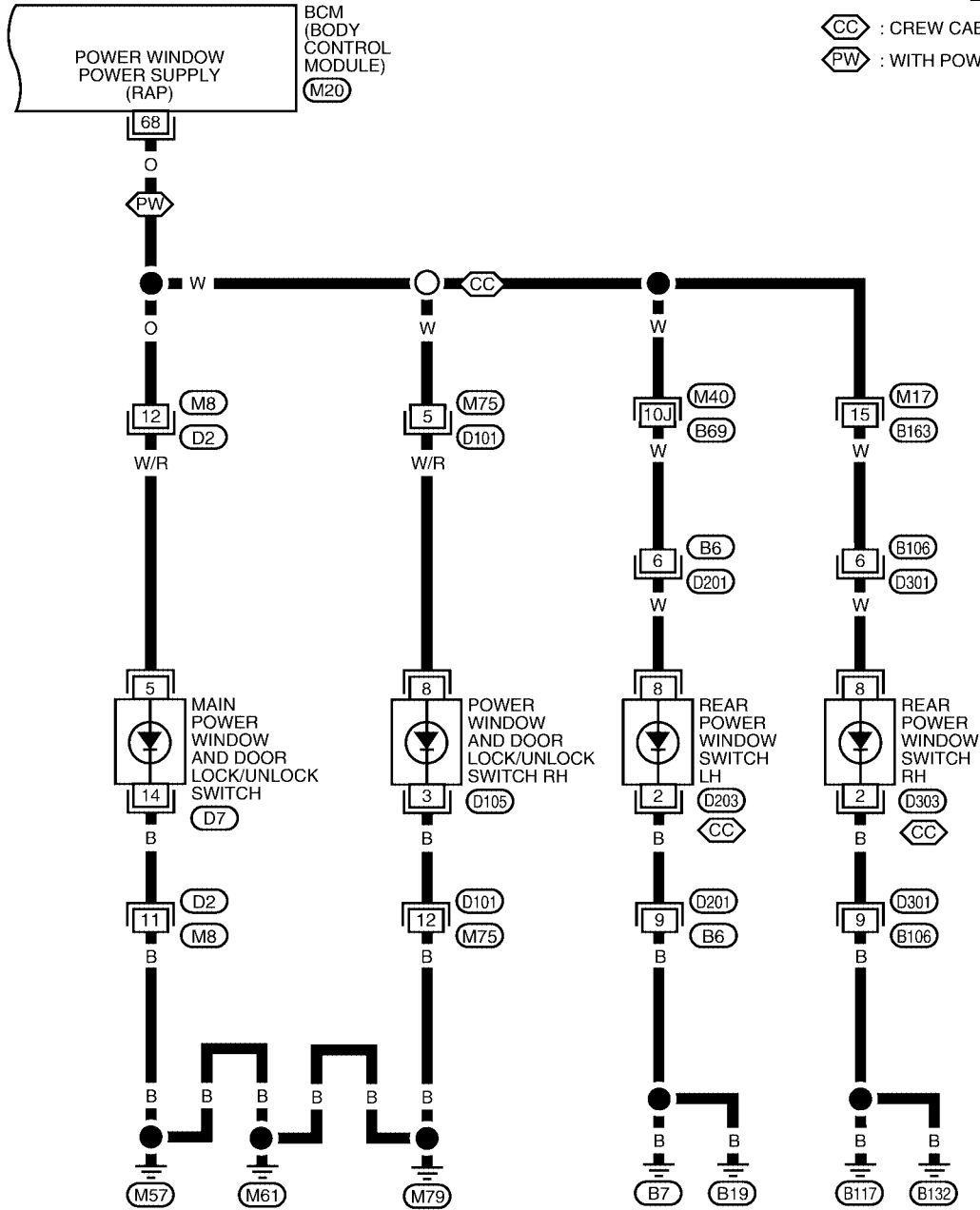

CC : CREW CAB  
PW : WITH POWER WINDOWS

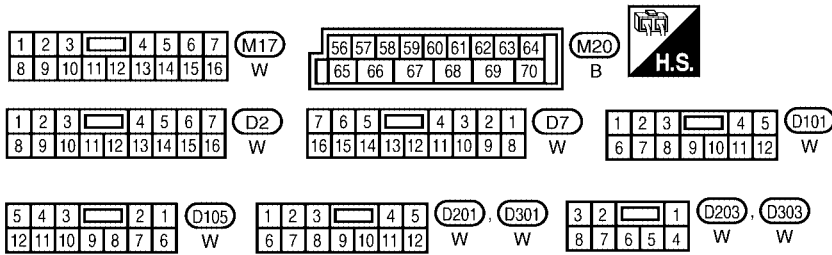

REFER TO THE FOLLOWING.  
M40 - SUPER MULTIPLE JUNCTION (SMJ)

WKWA4388E

# ILLUMINATION

## Removal and Installation

### ILLUMINATION CONTROL SWITCH

The illumination control switch is a function of the combination meter, and not serviced separately. For replacement, refer to [IP-13, "COMBINATION METER"](#)

EKS00BS9

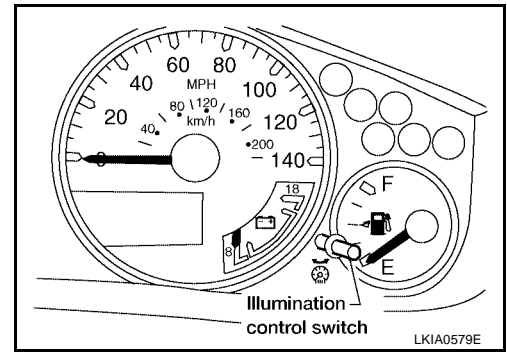

A  
B  
C  
D  
E  
F  
G  
H  
I  
J  
LT  
L  
M

# BULB SPECIFICATIONS

## BULB SPECIFICATIONS

PFP:26297

### Headlamp

EKS00BSA

Item	Wattage (W)*
Low/High	65/55 (HB5)

\*: Always check with the Parts Department for the latest parts information.

### Exterior Lamp

EKS00BSB

Item	Wattage (W)*	
Front combination lamp	Turn signal lamp/parking lamp	28/8
	Side marker	3.8
Rear combination lamp	Stop/Tail lamp	27/8
	Turn signal lamp	27
	Back-up lamp	18
Fog lamp	55	
License plate lamp	5	
High-mounted stop lamp	16	
Cargo lamp (in high-mounted stop lamp)	16	

\*: Always check with the Parts Department for the latest parts information.

### Interior Lamp/Illumination

EKS00BSC

Item	Wattage (W)*
Room lamp	8
A/T device lamp	3
Vanity lamp	*
Map/Personal lamp	8

\*: Always check with the Parts Department for the latest parts information.