

SECTION **CL**  
CLUTCH

A  
B  
C

CL

CONTENTS

E

<b>SYMPTOM DIAGNOSIS</b> .....	3	<b>OPERATING CYLINDER</b> .....	13	F
<b>NOISE, VIBRATION AND HARSHNESS (NVH) TROUBLESHOOTING</b> .....	3	Exploded View .....	13	
NVH Troubleshooting Chart .....	3	Removal and Installation .....	13	
<b>PRECAUTION</b> .....	4	<b>CLUTCH PIPING</b> .....	14	G
<b>PRECAUTIONS</b> .....	4	Exploded View .....	14	
Caution for Supplemental Restraint System (SRS) "AIR BAG" and "SEAT BELT PRE-TENSIONER" .....	4	Removal and Installation .....	14	H
Caution for Procedure without Cowl Top Cover.....	4	<b>UNIT REMOVAL AND INSTALLATION</b> .....	15	
Service Notice or Precautions .....	4	<b>CLUTCH RELEASE MECHANISM</b> .....	15	I
<b>PREPARATION</b> .....	6	<b>5M/T</b> .....	15	
<b>PREPARATION</b> .....	6	5M/T : Exploded View .....	15	J
Special Service Tool .....	6	5M/T : Removal and Installation .....	15	
Commercial Service Tool .....	6	5M/T : Inspection .....	16	
<b>PERIODIC MAINTENANCE</b> .....	8	<b>6M/T</b> .....	16	K
<b>CLUTCH PEDAL</b> .....	8	6M/T : Exploded View .....	17	
On-Vehicle Inspection and Adjustment .....	8	6M/T : Removal and Installation .....	17	
<b>CLUTCH FLUID</b> .....	9	6M/T : Inspection .....	18	L
Bleeding .....	9	<b>CLUTCH DISC, CLUTCH COVER</b> .....	20	
<b>REMOVAL AND INSTALLATION</b> .....	10	<b>5M/T</b> .....	20	M
<b>CLUTCH PEDAL</b> .....	10	5M/T : Exploded View .....	20	
Exploded View .....	10	5M/T : Removal and Installation .....	20	
Removal and Installation .....	10	5M/T : Inspection after Removal .....	21	N
Inspection .....	10	5M/T : Adjustment after Installation .....	22	
<b>CLUTCH MASTER CYLINDER</b> .....	11	<b>6M/T</b> .....	22	O
Exploded View .....	11	6M/T : Exploded View .....	22	
Removal and Installation .....	11	6M/T : Removal and Installation .....	23	
<b>CLUTCH RESERVOIR</b> .....	12	6M/T : Inspection after Removal .....	23	P
Removal and Installation .....	12	6M/T : Adjustment after Installation .....	24	
		<b>SERVICE DATA AND SPECIFICATIONS (SDS)</b> .....	25	
		<b>SERVICE DATA AND SPECIFICATIONS (SDS)</b> .....	25	
		Clutch Control System .....	25	
		Clutch Master Cylinder .....	25	

---

Clutch Operating Cylinder .....	25	Clutch Cover .....	25
Clutch Disc .....	25	Clutch Pedal .....	26

# NOISE, VIBRATION AND HARSHNESS (NVH) TROUBLESHOOTING

< SYMPTOM DIAGNOSIS >

## SYMPTOM DIAGNOSIS

### NOISE, VIBRATION AND HARSHNESS (NVH) TROUBLESHOOTING

#### NVH Troubleshooting Chart

INFOID:000000006251264

Use the chart below to help you find the cause of the symptom. The numbers indicate the order of the inspection. If necessary, repair or replace these parts.

#### CLUTCH

Reference page		CL-8				CL-9		BR-48		CL-13		EM-7Z (QR25DE), EM-216 (VQ40DE)		CL-15 (5M/T), CL-17 (6 M/T)		CL-20 (5M/T), CL-22 (6M/T)		EM-91 (QR25DE), EM-231 (VQ40DE)	
SYMPTOM		SUSPECTED PARTS (Possible cause)																	
		CLUTCH PEDAL (Inspection and adjustment)	CLUTCH LINE (Air in line)	MASTER CYLINDER PISTON CUP (Damaged)	OPERATING CYLINDER PISTON CUP (Damaged)	ENGINE MOUNTING (Loose)	RELEASE BEARING (Worn, dirty or damaged)	CLUTCH DISC (Out of true)	CLUTCH DISC (Runout is excessive)	CLUTCH DISC (Lining broken)	CLUTCH DISC (Dirty or burned)	CLUTCH DISC (Oily)	CLUTCH DISC (Worn out)	CLUTCH DISC (Hardened)	CLUTCH DISC (Lack of spline grease)	DIAPHRAGM SPRING (Damaged)	DIAPHRAGM SPRING (Out of tip alignment)	PRESSURE PLATE (Distortion)	FLYWHEEL (Distortion)
Symptom	Clutch grabs/chatters					1			2			2	2	2			2		
	Clutch pedal spongy		1	2	2														
	Clutch noisy						1												
	Clutch slips	1										2	2			3		4	5
	Clutch does not disengage	1	2	3	4			5	5	5	5	5			5	6	6	7	

# PRECAUTIONS

< PRECAUTION >

## PRECAUTION

### PRECAUTIONS

#### Precaution for Supplemental Restraint System (SRS) "AIR BAG" and "SEAT BELT PRE-TENSIONER"

INFOID:000000006251265

The Supplemental Restraint System such as "AIR BAG" and "SEAT BELT PRE-TENSIONER", used along with a front seat belt, helps to reduce the risk or severity of injury to the driver and front passenger for certain types of collision. This system includes seat belt switch inputs and dual stage front air bag modules. The SRS system uses the seat belt switches to determine the front air bag deployment, and may only deploy one front air bag, depending on the severity of a collision and whether the front occupants are belted or unbelted. Information necessary to service the system safely is included in the SR and SB section of this Service Manual.

#### **WARNING:**

- To avoid rendering the SRS inoperative, which could increase the risk of personal injury or death in the event of a collision which would result in air bag inflation, all maintenance must be performed by an authorized NISSAN/INFINITI dealer.
- Improper maintenance, including incorrect removal and installation of the SRS, can lead to personal injury caused by unintentional activation of the system. For removal of Spiral Cable and Air Bag Module, see the SR section.
- Do not use electrical test equipment on any circuit related to the SRS unless instructed to in this Service Manual. SRS wiring harnesses can be identified by yellow and/or orange harnesses or harness connectors.

#### PRECAUTIONS WHEN USING POWER TOOLS (AIR OR ELECTRIC) AND HAMMERS

#### **WARNING:**

- When working near the Airbag Diagnosis Sensor Unit or other Airbag System sensors with the Ignition ON or engine running, DO NOT use air or electric power tools or strike near the sensor(s) with a hammer. Heavy vibration could activate the sensor(s) and deploy the air bag(s), possibly causing serious injury.
- When using air or electric power tools or hammers, always switch the Ignition OFF, disconnect the battery, and wait at least 3 minutes before performing any service.

#### Precaution for Procedure without Cowl Top Cover

INFOID:000000006251266

When performing the procedure after removing cowl top cover, cover the lower end of windshield with urethane, etc.

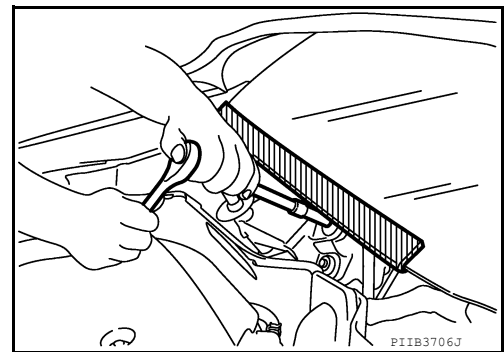

#### Service Notice or Precautions

INFOID:000000006251267

- Always use recommended fluid. Refer to [MA-16. "FOR USA AND CANADA : Fluids and Lubricants"](#).
- Never reuse drained fluid.
- Be careful not to splash fluid on painted areas.

## PRECAUTIONS

### < PRECAUTION >

- When removing and installing clutch piping, use tool.
- Use new fluid to clean or wash all parts of master cylinder.
- Never use mineral oils such as gasoline or kerosene. It will ruin the rubber parts of the hydraulic system.

### **WARNING:**

**After cleaning clutch disc, wipe it with a dust collector. Do not use compressed air.**

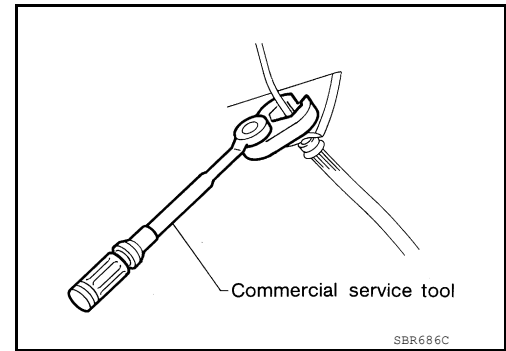

A  
B  
C

CL

E  
F  
G  
H  
I  
J  
K  
L  
M  
N  
O  
P

# PREPARATION

< PREPARATION >

## PREPARATION

### PREPARATION

#### Special Service Tool

INFOID:000000006251268

The actual shapes of Kent-Moore tools may differ from those of special service tools illustrated here.

Tool number (Kent-Moore No.) Tool name	Description
ST20050240 ( — ) Diaphragm adjusting wrench	Adjusting unevenness of diaphragm spring of clutch cover
ST20630000 (J-26366) Clutch aligning bar	Installing clutch disc <b>a: 15.8 mm (0.622 in) dia.</b> <b>b: 22.9 mm (0.902 in) dia.</b>



ZZA0508D

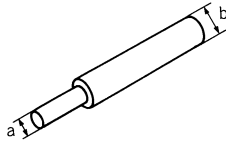

ZZA1178D

#### Commercial Service Tool

INFOID:000000006251269

Tool name	Description
Power tool	Loosening bolts, nuts and screws
1. Flare nut crowfoot 2. Torque wrench	Removing and installing clutch piping <b>a: 10 mm (0.39 in)</b>



PIIB1407E

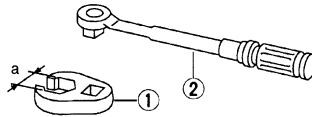

S-NT360

# PREPARATION

## < PREPARATION >

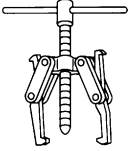
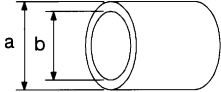
Tool name	Description
Bearing puller   NT077	Removing release bearing
Bearing drift   NT474	Installing release bearing <b>a: 52 mm (2.05 in) dia.</b> <b>b: 45 mm (1.77 in) dia.</b>

A  
B  
C  
CL  
E  
F  
G  
H  
I  
J  
K  
L  
M  
N  
O  
P

# CLUTCH PEDAL

< PERIODIC MAINTENANCE >

## PERIODIC MAINTENANCE

### CLUTCH PEDAL

#### On-Vehicle Inspection and Adjustment

INFOID:000000006251270

1. Check to see if the clevis pin floats freely in the bore of the clutch pedal. It should not be bound by the clevis or clutch pedal.
  - a. If the clevis pin is not free, check that the pedal stopper bolt or ASCD clutch switch is not applying pressure to the clutch pedal causing the clevis pin to bind. To adjust, loosen the lock nut and turn the pedal stopper bolt or ASCD clutch switch.
  - b. Tighten the lock nut to the specified torque. Refer to [CL-10, "Exploded View"](#).
  - c. Verify that the clevis pin floats in the bore of the clutch pedal. It should not be bound by the clutch pedal.
  - d. If the clevis pin is still not free, remove the clevis pin and check for deformation or damage. Replace clevis pin if necessary. Leave pin removed for step 2.
2. Check clutch pedal stroke for free range of movement.
  - a. With the clevis pin removed, manually move the clutch pedal up and down to determine if it moves freely.
  - b. If any sticking is noted, replace the assembly.
3. Adjust clearance "(C)" while depressing clutch pedal fully. (With clutch interlock switch)

**Clearance (C) : 0.1 - 1.0 mm (0.004 - 0.039 in)**

4. Check clutch hydraulic and system components (clutch master cylinder, clutch operating cylinder, clutch withdrawal lever and clutch release bearing) for sticking or binding.
  - a. If any sticking or binding noted, repair or replace related parts as necessary.
  - b. If hydraulic system repair was necessary, bleed the clutch hydraulic system. Refer to [CL-9, "Bleeding"](#).

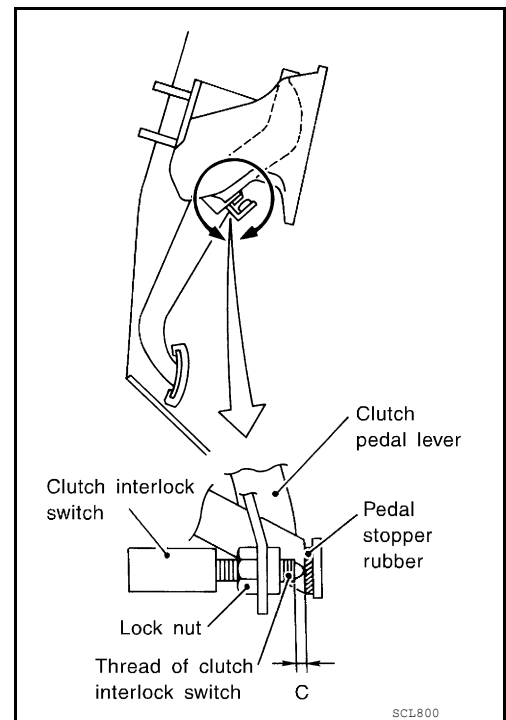
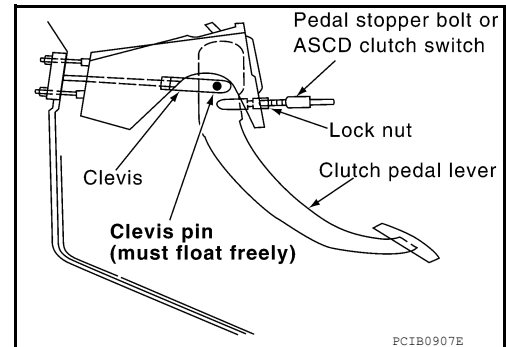



# CLUTCH FLUID

< PERIODIC MAINTENANCE >

## CLUTCH FLUID

### Bleeding

INFOID:000000006251271

#### **CAUTION:**

**Do not spill clutch fluid onto painted surfaces. If it spills, wipe up immediately and wash the affected area with water.**

#### **NOTE:**

Monitor the fluid level in the reservoir tank to make sure it does not empty.

1. Top off reservoir with new recommended brake fluid. Refer to [MA-16, "FOR USA AND CANADA : Fluids and Lubricants"](#).
2. Connect a transparent vinyl tube and container to the air bleeder valve on the clutch operating cylinder.
3. Fully depress the clutch pedal several times.
4. With the clutch pedal depressed, open the bleeder valve to release the air.
5. Close the bleeder valve.
6. Repeat steps 3 to 5 until clear brake fluid comes out of the air bleeder valve.
7. Tighten the air bleeder to the specified torque.

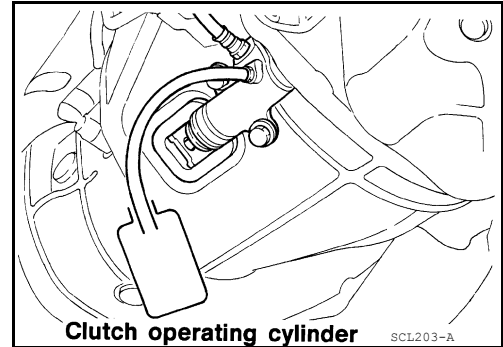

**Air bleeder      7.9 N·m (0.81 kg-m, 70 in-lb)**

# CLUTCH PEDAL

< REMOVAL AND INSTALLATION >

## REMOVAL AND INSTALLATION

### CLUTCH PEDAL

Exploded View

INFOID:000000006251272

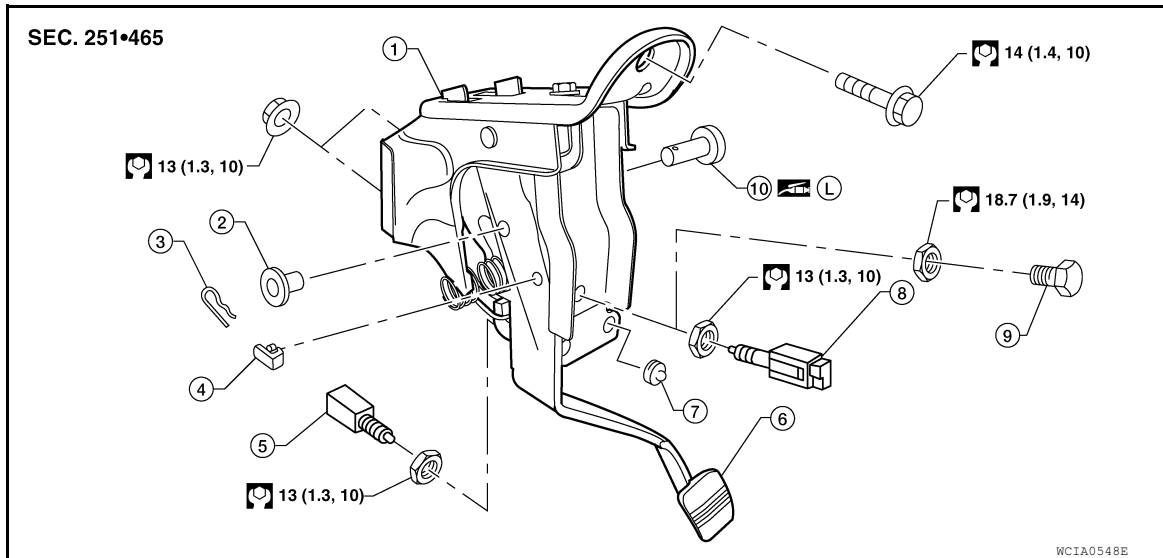

- |                         |                                   |                                      |
|-------------------------|-----------------------------------|--------------------------------------|
| 1. Bracket              | 2. Bushing                        | 3. Snap pin                          |
| 4. Pedal stopper rubber | 5. Clutch interlock switch        | 6. Clutch pedal                      |
| 7. Stopper rubber       | 8. ASCD clutch switch (with ASCD) | 9. Pedal stopper bolt (without ASCD) |
| 10. Clevis pin          |                                   |                                      |

### Removal and Installation

INFOID:000000006251273

#### REMOVAL

1. Remove the clutch pedal bracket nuts from inside the engine compartment.
2. Disconnect the clutch interlock switch and ASCD clutch switch (if equipped), then remove the wiring harness from the pedal assembly.
3. Remove the snap pin and clevis pin.
4. Remove the pedal bracket bolt and then remove the clutch pedal assembly.

#### INSTALLATION

Installation is in the reverse order of removal.

#### NOTE:

Tighten the pedal stopper bolt lock nut or ASCD clutch switch lock nut to the specified torque after installing the clutch pedal assembly in the vehicle and adjusting the pedal free play.

#### Inspection

INFOID:000000006251274

#### INSPECTION AFTER REMOVAL

- Inspect the clutch pedal for bends, damage, or cracked welds. Replace if necessary.
- Make sure that the assist spring and return spring have not lost their spring. Replace if necessary.

# CLUTCH MASTER CYLINDER

< REMOVAL AND INSTALLATION >

## CLUTCH MASTER CYLINDER

Exploded View

INFOID:000000008180419

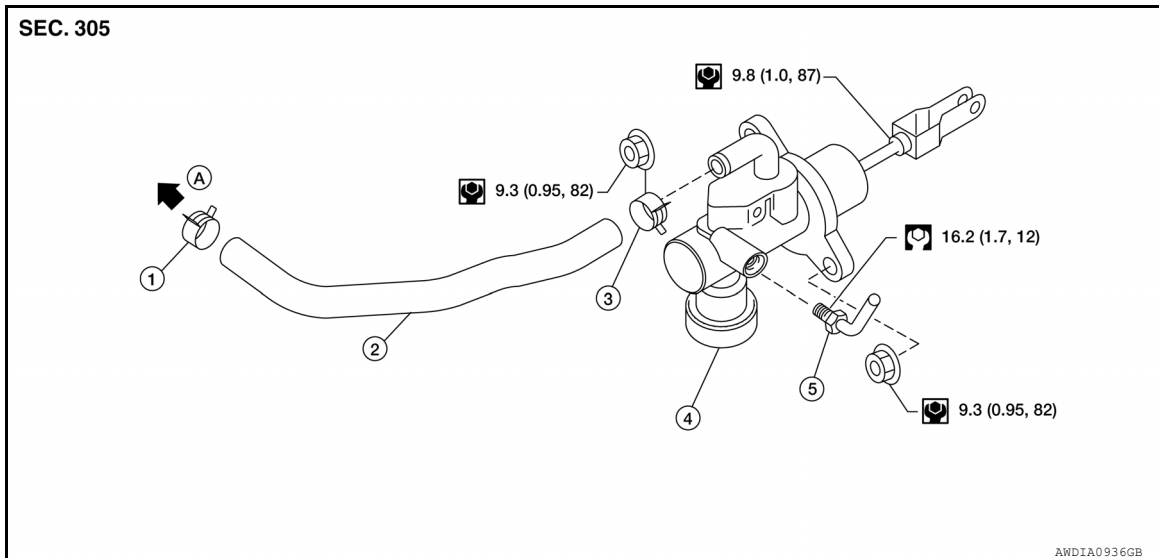

- |                  |                   |                      |
|------------------|-------------------|----------------------|
| 1. Clamp         | 2. Reservoir hose | 3. Clamp             |
| 4. Cylinder body | 5. Clutch tube    | A. To reservoir tank |

### Removal and Installation

INFOID:000000006251275

#### CAUTION:

Do not spill brake fluid onto painted surfaces. If it spills, wipe up immediately and wash the affected area with water.

#### NOTE:

When removing components such as hoses, tubes/lines, ect., cap or plug openings to prevent fluid from spilling.

#### REMOVAL

1. Remove the snap pin and clevis pin from the clevis, and separate it from the clutch pedal.
2. Remove the hose clamp and hose from the clutch master cylinder.
3. Remove the clutch tube using suitable tool.
4. Remove the clutch master cylinder nuts, and remove the clutch master cylinder from the vehicle.

#### INSTALLATION

Installation is in the reverse order of removal.

- Before installation, check the position of the clevis and push rod. If (L) is outside standard length, adjust the position of the clevis and push rod.

#### Length (L)

QR25DE : 119.5 mm (4.70 in)

VQ40DE : 120.5 mm (4.74 in)

- After installation, inspect and adjust the clutch pedal as necessary, then bleed the clutch hydraulic system. Refer to [CL-8, "On-Vehicle Inspection and Adjustment"](#) and [CL-9, "Bleeding"](#).

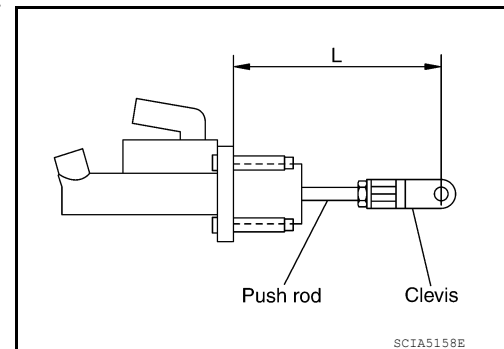

# CLUTCH RESERVOIR

< REMOVAL AND INSTALLATION >

---

## CLUTCH RESERVOIR

### Removal and Installation

INFOID:000000006251276

For removal and installation of clutch reservoir, refer to [BR-33, "Removal and Installation"](#).

**NOTE:**

- Be sure to check clutch fluid after installation. Refer to [BR-21, "Drain and Refill"](#).
- Be sure to bleed clutch system after installation. Refer to [CL-9, "Bleeding"](#).

# OPERATING CYLINDER

< REMOVAL AND INSTALLATION >

## OPERATING CYLINDER

### Exploded View

INFOID:000000008180423

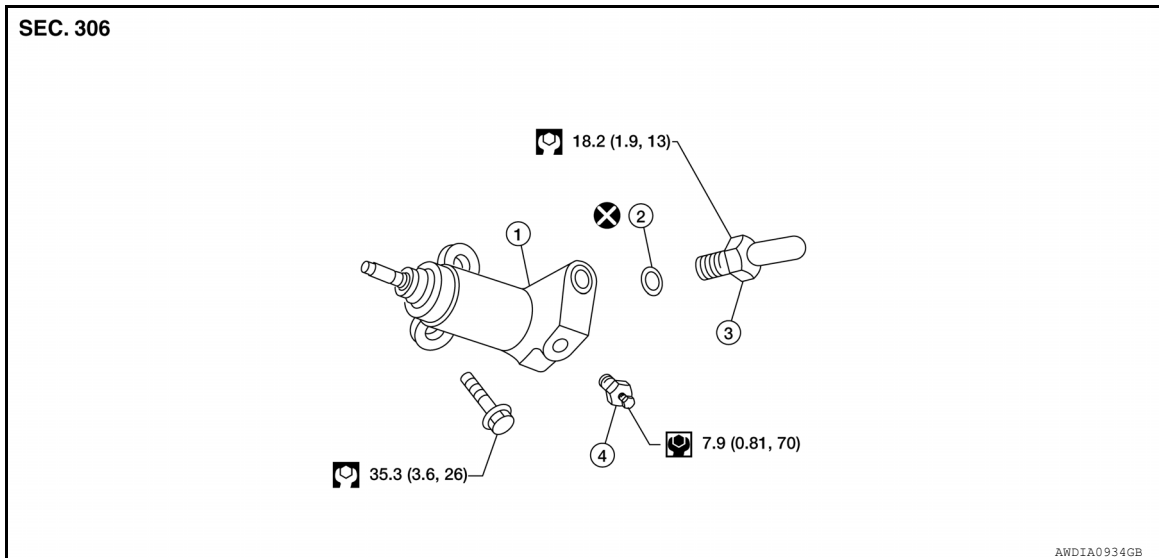

1. Operating cylinder
2. Copper sealing washer
3. Clutch hose
4. Air bleeder

### Removal and Installation

INFOID:000000006251277

#### CAUTION:

**Do not spill brake fluid on painted surfaces. If it spills, wipe up immediately and wash the affected area with water.**

#### NOTE:

When removing components such as hoses, tubes/lines, ect., cap or plug openings to prevent fluid from spilling.

#### REMOVAL

1. Remove the clutch hose and copper sealing washer from the operating cylinder.

#### CAUTION:

**Do not reuse the copper sealing washer.**

2. Remove the operating cylinder bolts, and remove the operating cylinder from the vehicle.

#### INSTALLATION

Installation is in the reverse order of removal.

- Tighten the clutch hose fitting to the specified torque.

#### CAUTION:

- **Make sure the clutch hose is not bent or twisted.**
- **Do not reuse copper sealing washers.**
- After installation, bleed the clutch hydraulic system. Refer to [CL-9, "Bleeding"](#).

# CLUTCH PIPING

< REMOVAL AND INSTALLATION >

## CLUTCH PIPING

### Exploded View

INFOID:000000006251278

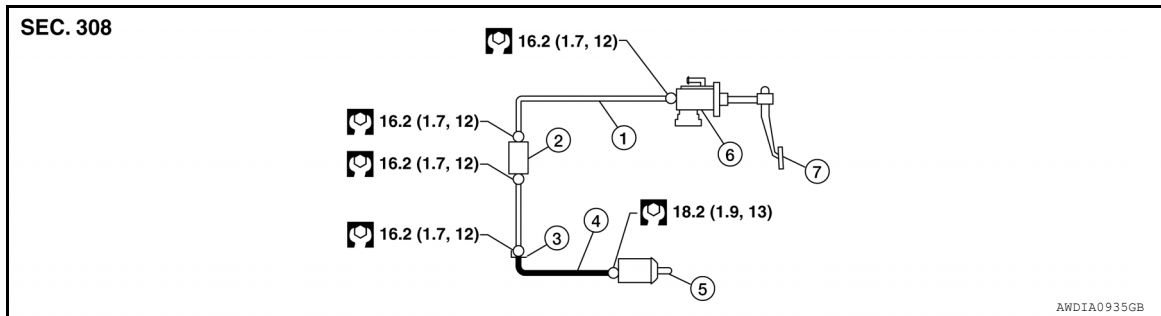

- |                 |                       |                    |
|-----------------|-----------------------|--------------------|
| 1. Clutch tube  | 2. Clutch orifice     | 3. Lock plate      |
| 4. Clutch hose  | 5. Operating Cylinder | 6. Master cylinder |
| 7. Clutch pedal |                       |                    |

### Removal and Installation

INFOID:000000006251279

Carefully observe the following during clutch tube removal and installation.

#### CAUTION:

**Do not spill brake fluid onto painted surfaces. If it spills, wipe up immediately and wash the affected area with water.**

- When installing the clutch hose to the bracket, align the clutch hose metal fittings with the bracket positioning emboss, then install the lock plate to secure.

#### CAUTION:

- Do not damage the clutch hose.
- Make sure the clutch hose is not bent or twisted.
- Tighten the clutch tube and hose fittings to the specified torque.

#### CAUTION:

- Do not reuse the copper washer.
- Do not damage the clutch tube fittings or clutch tube.
- After installation, bleed the air from the clutch hydraulic system. Refer to [CL-9, "Bleeding"](#).

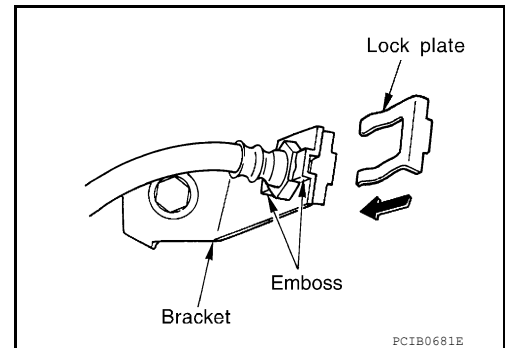

# CLUTCH RELEASE MECHANISM

< UNIT REMOVAL AND INSTALLATION >

## UNIT REMOVAL AND INSTALLATION

### CLUTCH RELEASE MECHANISM

5M/T

5M/T : Exploded View

INFOID:000000006251280

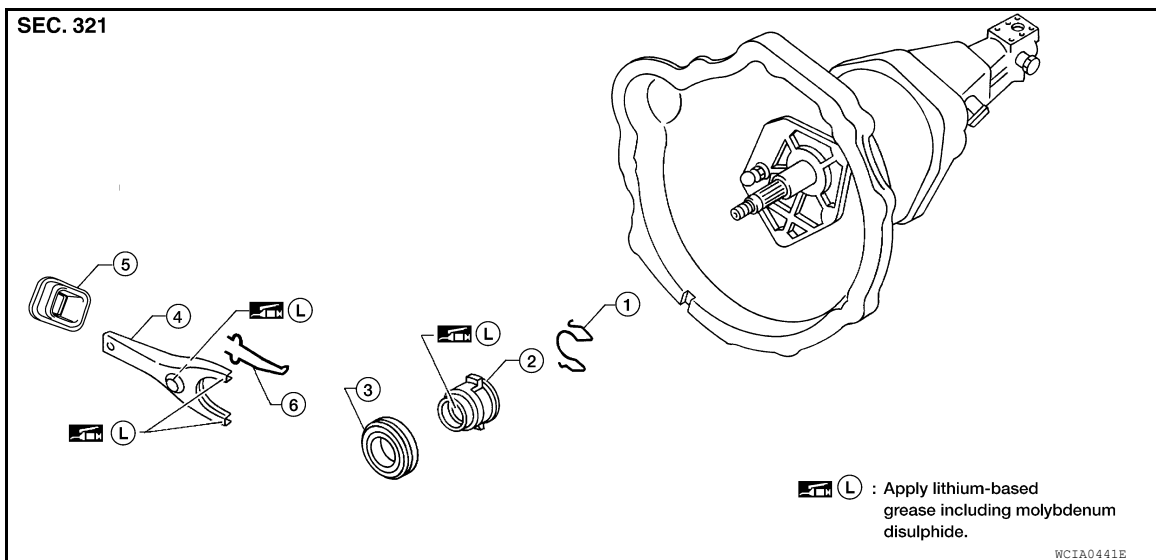

- |                     |                           |                    |
|---------------------|---------------------------|--------------------|
| 1. Holder spring    | 2. Release bearing sleeve | 3. Release bearing |
| 4. Withdrawal lever | 5. Dust cover             | 6. Retainer spring |

### 5M/T : Removal and Installation

INFOID:000000006251281

#### REMOVAL

1. Remove the manual transmission from the vehicle. Refer to [TM-20, "Removal and Installation from Vehicle"](#).
2. Remove the release bearing sleeve assembly, holder spring, and withdrawal lever from inside the clutch housing.
3. Remove the dust cover.
4. Remove the retainer spring from the withdrawal lever.
5. Remove the release bearing from release bearing sleeve using suitable tool.

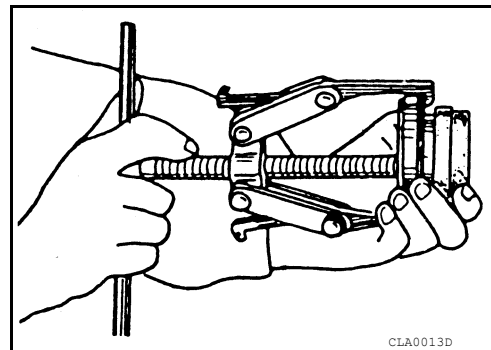

#### INSTALLATION

Installation is in the reverse order of removal.

**NOTE:**

# CLUTCH RELEASE MECHANISM

## < UNIT REMOVAL AND INSTALLATION >

- Install the release bearing to release bearing sleeve using suitable tool, as shown.

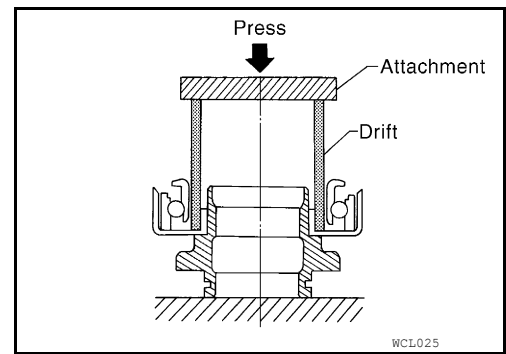

- Clean old grease and abrasive materials off the grease application areas.
- Apply grease to the specified points as shown.

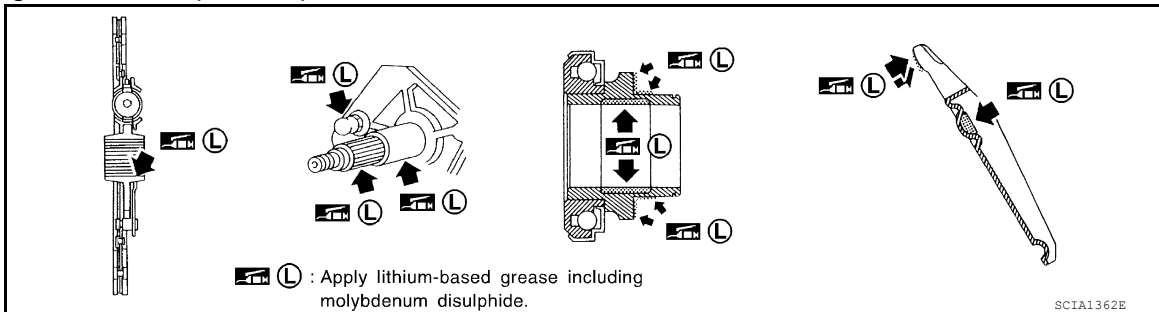

- Apply approximately 1 mm (0.04 in) thick coat of clutch sleeve grease to withdrawal lever and holder spring frictional surfaces.
- Apply a coat of clutch sleeve grease to ball pin contact surface of the withdrawal lever and inner slots of the release bearing. The grease surface should be level with the surrounding area.
- Apply a thin coat of clutch sleeve grease to the release bearing frictional surface. After grease application, install release bearing. Wipe off excess grease forced out during bearing installation.

### CAUTION:

- Be careful not to bring any grease into contact with the clutch disc facing, pressure plate surface, or flywheel surface.
- Before installing manual transmission to the vehicle, check that each sliding surface slides smoothly by operating withdrawal lever.

## 5M/T : Inspection

INFOID:000000006251282

### INSPECTION AFTER REMOVAL

- Replace the release bearing if it is seized, damaged, faulty in rotation direction, or has poor aligning function.
- Replace the withdrawal lever if its contact surface is worn abnormally.
- Replace the dust seal if it is deformed or cracked.

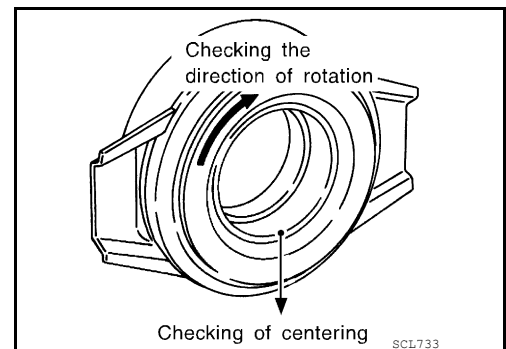

## 6M/T



# CLUTCH RELEASE MECHANISM

< UNIT REMOVAL AND INSTALLATION >

6M/T : Exploded View

INFOID:000000006251283

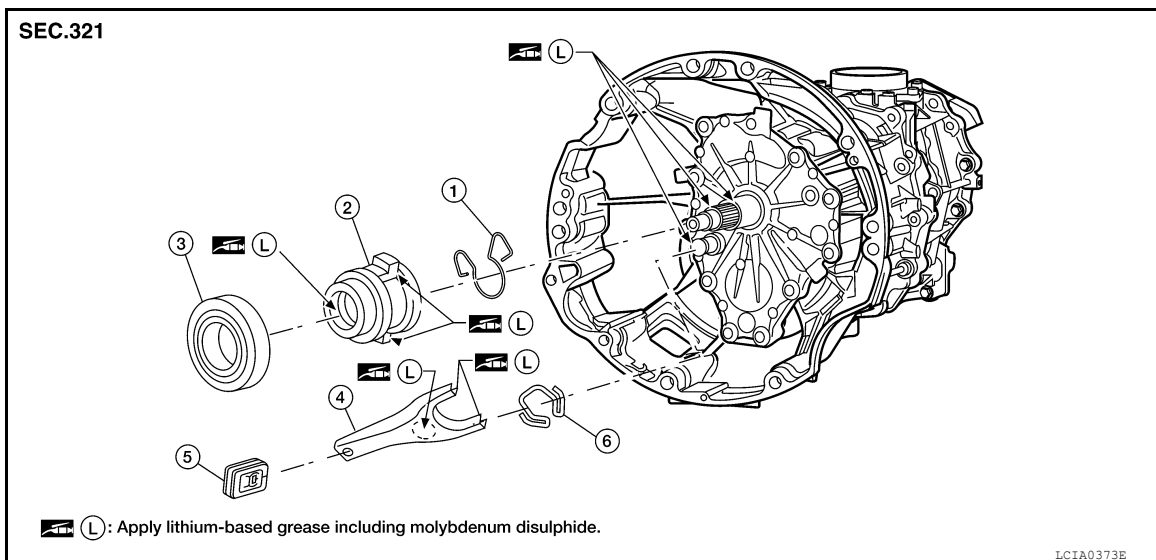

- |                     |                           |                    |
|---------------------|---------------------------|--------------------|
| 1. Holder spring    | 2. Release bearing sleeve | 3. Release bearing |
| 4. Withdrawal lever | 5. Dust cover             | 6. Snap spring     |

6M/T : Removal and Installation

INFOID:000000006251284

## REMOVAL

1. Remove the manual transmission from the vehicle. Refer to [TM-71, "Removal and Installation from Vehicle \(For 2WD Models\)"](#) or [TM-73, "Removal and Installation from Vehicle \(For 4WD Models\)"](#).
2. Remove the release bearing sleeve assembly, holder spring, and withdrawal lever from inside the clutch housing.
3. Remove the dust cover.
4. Remove the snap spring from the withdrawal lever.
5. Remove the release bearing from release bearing sleeve using suitable tool.

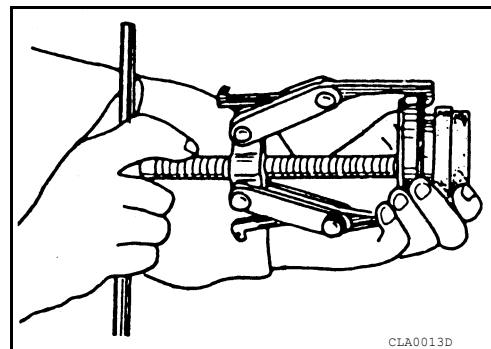

## INSTALLATION

Installation is in the reverse order of removal.

**NOTE:**

# CLUTCH RELEASE MECHANISM

## < UNIT REMOVAL AND INSTALLATION >

- Install the release bearing to release bearing sleeve using suitable tool, as shown.

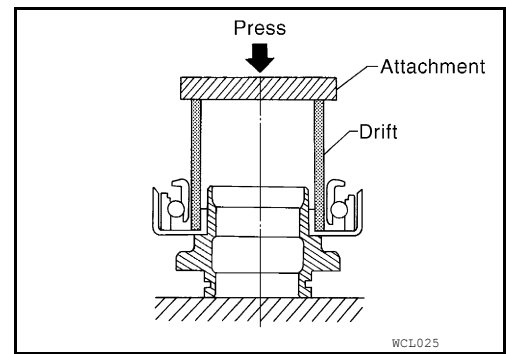

- Clean old grease and abrasive materials off the grease application areas.
- Apply grease to the specified points as shown.

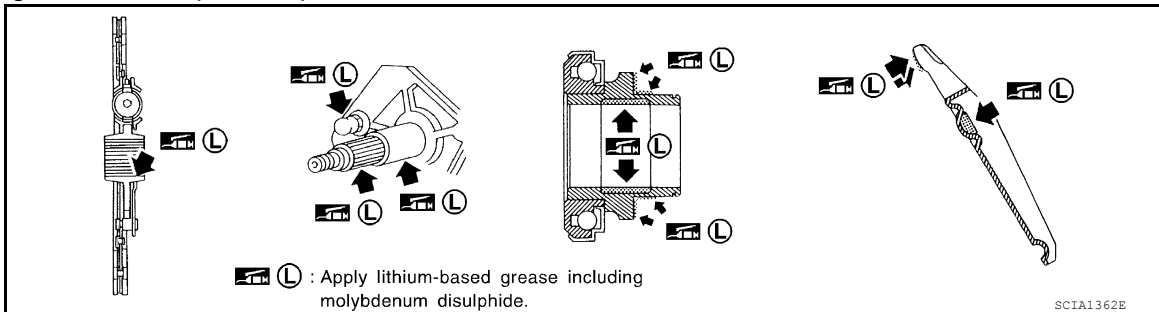

- Apply approximately 1 mm (0.04 in) thick coat of clutch sleeve grease to withdrawal lever and holder spring frictional surfaces.
- Apply a coat of clutch sleeve grease to ball pin contact surface of the withdrawal lever and inner slots of the release bearing. The grease surface should be level with the surrounding area.
- Apply a thin coat of clutch sleeve grease to the release bearing frictional surface. After grease application, install release bearing. Wipe off excess grease forced out during bearing installation.

### CAUTION:

- Before installing the manual transmission to the vehicle, check that each sliding surface slides smoothly by operating withdrawal lever.
- Be careful not to bring any grease into contact with the clutch disc facing, pressure plate surface, or flywheel surface.
- When assembling, make sure that both ends of the snap spring touch the end face of the withdrawal lever.
- Be careful with the orientation of the installation.

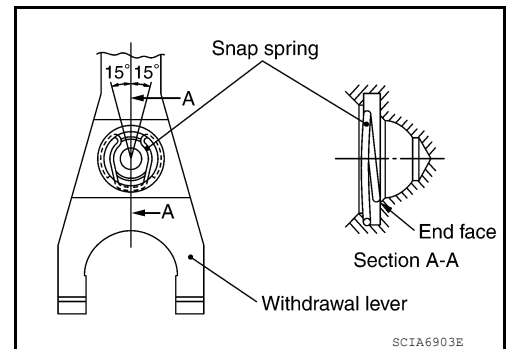

6M/T : Inspection

INFOID:000000006251285

INSPECTION AFTER REMOVAL

## CLUTCH RELEASE MECHANISM

### < UNIT REMOVAL AND INSTALLATION >

- Replace the release bearing if it is seized, damaged, faulty in rotation direction, or has poor aligning function.
- Replace the withdrawal lever if its contact surface is worn abnormally.
- Replace the dust seal if it is deformed or cracked.

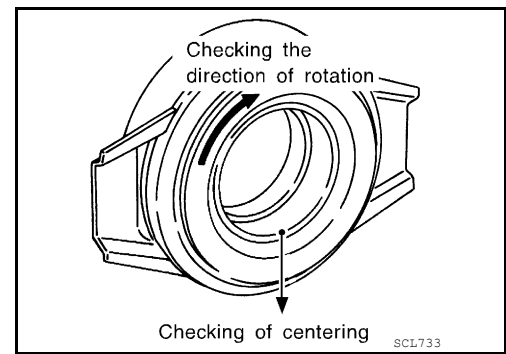

A  
B  
C

CL

E

F

G

H

I

J

K

L

M

N

O

P

# CLUTCH DISC, CLUTCH COVER

< UNIT REMOVAL AND INSTALLATION >

## CLUTCH DISC, CLUTCH COVER

5M/T

5M/T : Exploded View

INFOID:000000006251286

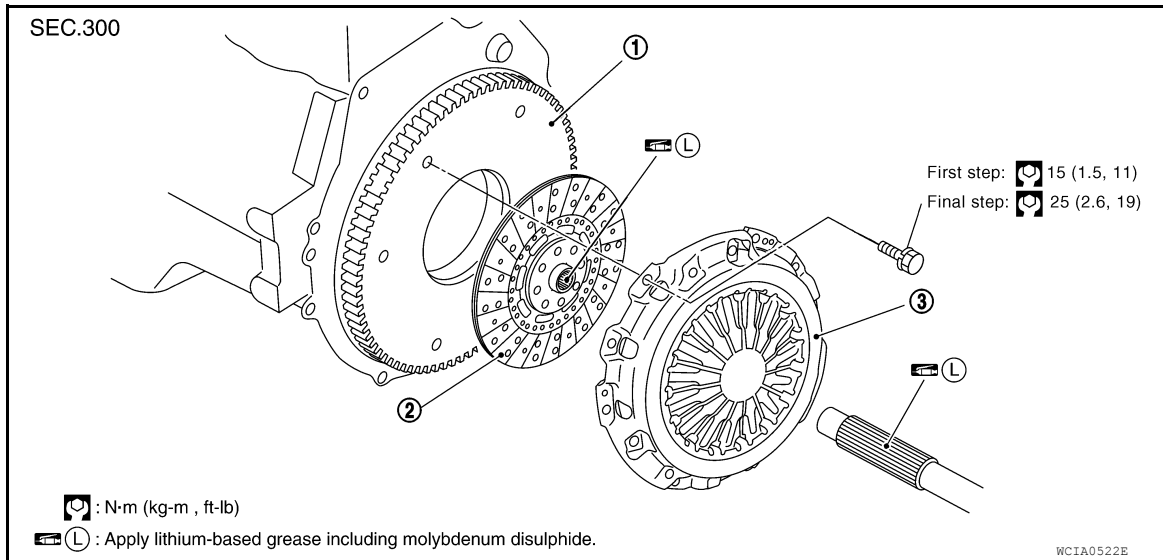

1. Flywheel

2. Clutch disc

3. Clutch cover

## 5M/T : Removal and Installation

INFOID:000000006251287

### CAUTION:

- Do not clean the clutch disc with solvent.
- When installing, do not get grease from the main drive shaft onto the clutch disc friction surface.

### REMOVAL

1. Remove the manual transmission from the vehicle. Refer to [TM-20, "Removal and Installation from Vehicle"](#).
2. Remove the clutch cover bolts using power tool. Remove the clutch cover and clutch disc.

### INSTALLATION

1. Apply recommended grease to clutch disc and main drive shaft spline.

### CAUTION:

**Do not allow grease to contaminate the clutch facing.**

# CLUTCH DISC, CLUTCH COVER

## < UNIT REMOVAL AND INSTALLATION >

- Install clutch disc and clutch cover. Pre-tighten the bolts and install Tool. Then tighten the clutch cover bolts evenly in two steps to the specified torque in the order shown. Refer to [CL-20, "5M/T : Exploded View"](#).

**Tool number : ST20630000 (J-26366)**

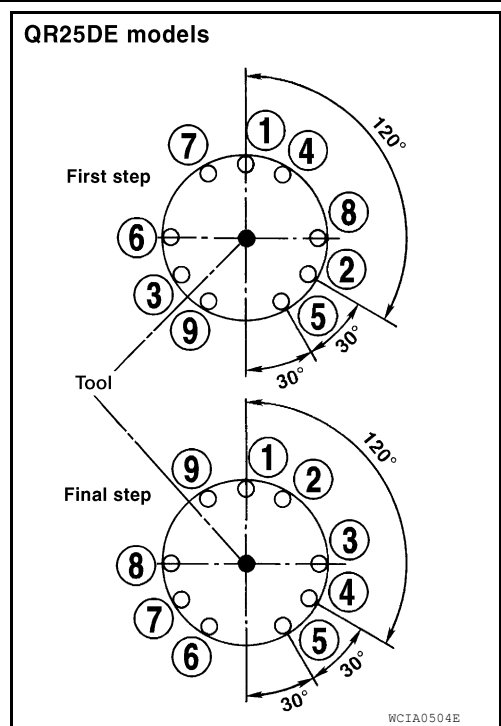

- Install the manual transmission. Refer to [TM-20, "Removal and Installation from Vehicle"](#).

## 5M/T : Inspection after Removal

INFOID:0000000006251288

### INSPECTION AFTER REMOVAL

#### Clutch Disc

- Check the wear of the clutch disc facing.

**Clutch disc facing wear : Refer to [CL-25, "Clutch Disc"](#).**

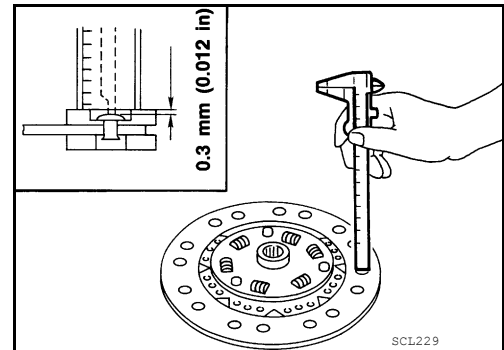

- Check the runout and backlash of the clutch disc. If the measurement exceeds the specification, replace the clutch disc.

**Runout and backlash : Refer to [CL-25, "Clutch Disc"](#).**

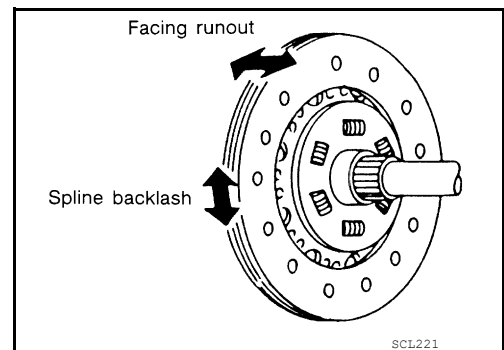

#### Clutch Cover

- Check clutch cover thrust ring for wear or damage. If wear or damage is found, replace clutch cover assembly.

#### NOTE:

- Worn thrust ring will generate a beating noise when tapped at the rivet with a hammer.

A  
B  
C  
CL  
E  
F  
G  
H  
I  
J  
K  
L  
M  
N  
O  
P

# CLUTCH DISC, CLUTCH COVER

## < UNIT REMOVAL AND INSTALLATION >

- Broken thrust ring will make a clinking sound when cover is shaken up and down.
- If a trace of burn or discoloration is found on the clutch cover pressure plate to clutch disc contact surface, repair the surface with emery paper. If surface is damaged or distorted, replace the assembly.

### Flywheel

- Check contact surface of flywheel for slight burns or discoloration. If any are found, repair flywheel with emery paper.
- Check the flywheel runout. Refer to [EM-91, "Inspection After Dis-assembly"](#).

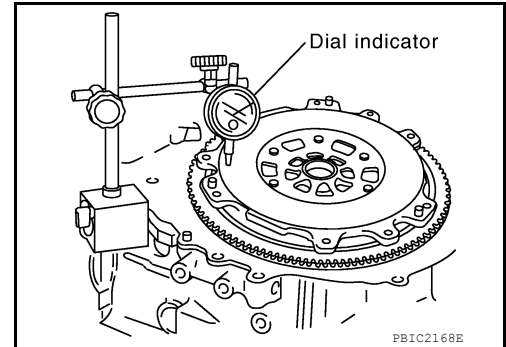

INFOID:000000006251289

## 5M/T : Adjustment after Installation

### ADJUSTMENT AFTER INSTALLATION

#### Clutch Cover

With the clutch cover installed on the vehicle, check the diaphragm spring toe height for unevenness. If unevenness exceeds the limit, adjust the diaphragm spring toe height using Tool.

**Uneven limit of diaphragm spring toe height** : Refer to [CL-25, "Clutch Cover"](#).

**Tool number** : ST20050240 ( — )

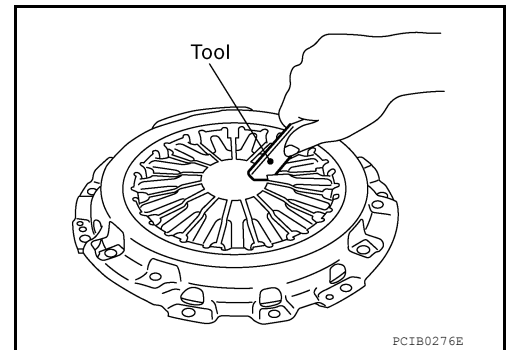

PCIB0276E

## 6M/T

## 6M/T : Exploded View

INFOID:000000006251290

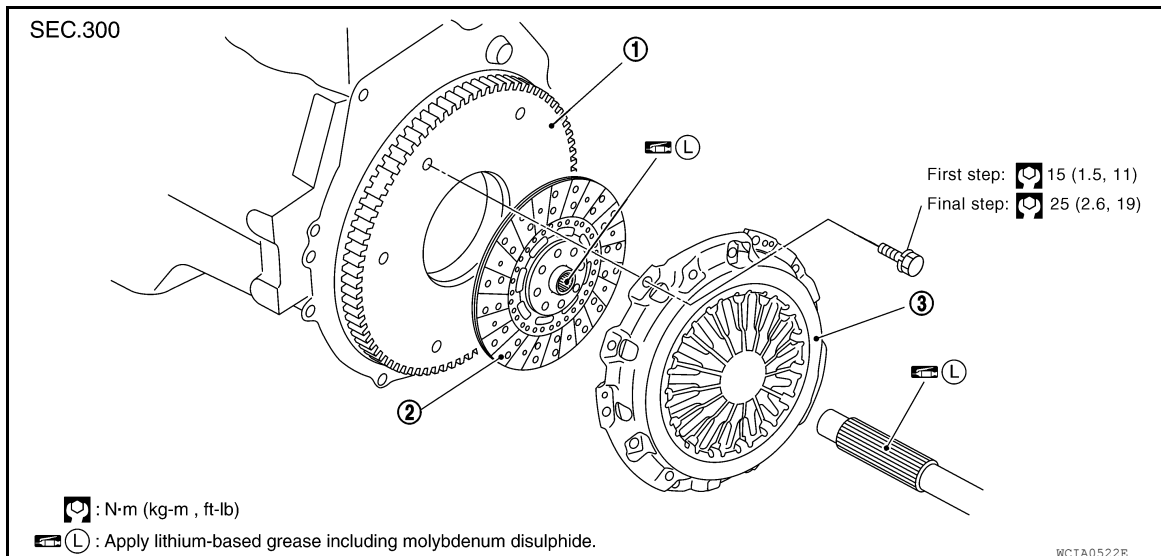

1. Flywheel

2. Clutch disc

3. Clutch cover

# CLUTCH DISC, CLUTCH COVER

< UNIT REMOVAL AND INSTALLATION >

## 6M/T : Removal and Installation

INFOID:000000006251291

### CAUTION:

- Do not clean the clutch disc with solvent.
- When installing, do not get grease from the main drive shaft onto the clutch disc friction surface.
- If the flywheel is removed, align the dowel pin with the smallest hole of flywheel. Refer to [EM-221, "Disassembly and Assembly"](#).

### REMOVAL

1. Remove the manual transmission from the vehicle. Refer to [TM-71, "Removal and Installation from Vehicle \(For 2WD Models\)"](#) or [TM-73, "Removal and Installation from Vehicle \(For 4WD Models\)"](#).
2. Remove the clutch cover bolts using power tool. Remove the clutch cover and clutch disc.

### INSTALLATION

1. Apply recommended grease to clutch disc and main drive shaft spline.

### CAUTION:

**Do not allow grease to contaminate the clutch facing.**

2. Install clutch disc and clutch cover. Pre-tighten the bolts and install Tool. Then tighten the clutch cover bolts evenly in two steps to the specified torque in the order shown. Refer to [CL-22, "6M/T : Exploded View"](#).

**Tool number** : ST20630000 (J-26366)

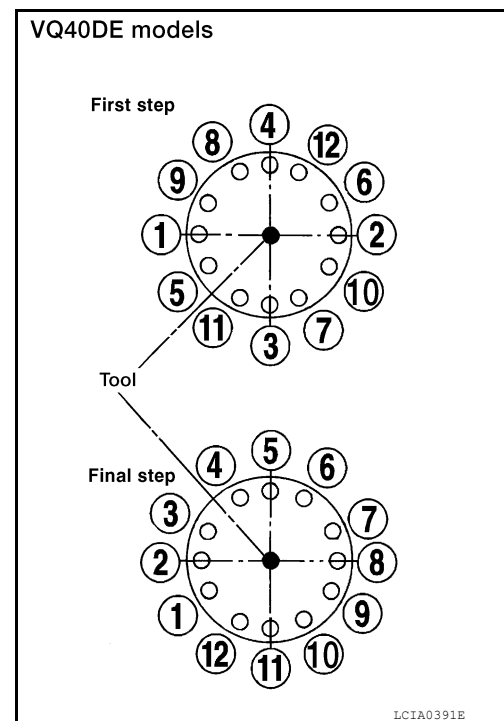

3. Install the manual transmission. Refer to [TM-71, "Removal and Installation from Vehicle \(For 2WD Models\)"](#) or [TM-73, "Removal and Installation from Vehicle \(For 4WD Models\)"](#).

## 6M/T : Inspection after Removal

INFOID:000000006251292

### INSPECTION AFTER REMOVAL

#### Clutch Disc

- Check the wear of the clutch disc facing.

**Clutch disc facing wear** : Refer to [CL-25, "Clutch Disc"](#).

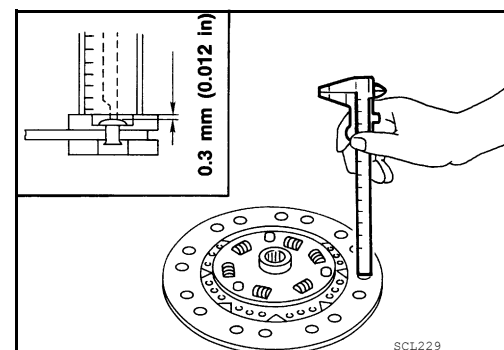

# CLUTCH DISC, CLUTCH COVER

## < UNIT REMOVAL AND INSTALLATION >

- Check the runout and backlash of the clutch disc. If the measurement exceeds the specification, replace the clutch disc.

**Runout and backlash** : Refer to [CL-25, "Clutch Disc"](#).

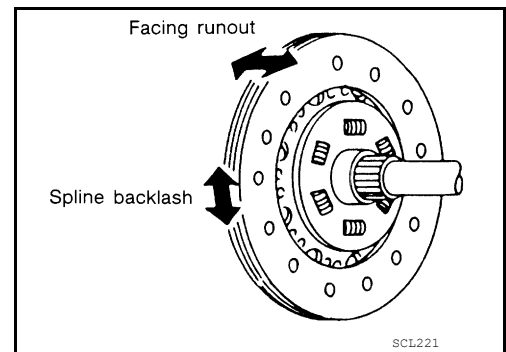

### Clutch Cover

- Check clutch cover thrust ring for wear or damage. If wear or damage is found, replace clutch cover assembly.

#### NOTE:

- Worn thrust ring will generate a beating noise when tapped at the rivet with a hammer.
- Broken thrust ring will make a clinking sound when cover is shaken up and down.
- If a trace of burn or discoloration is found on the clutch cover pressure plate to clutch disc contact surface, repair the surface with emery paper. If surface is damaged or distorted, replace the assembly.

### Flywheel

- Check contact surface of flywheel for slight burns or discoloration. If any are found, repair flywheel with emery paper.
- Check the flywheel runout. Refer to [EM-231, "Inspection After Disassembly"](#).

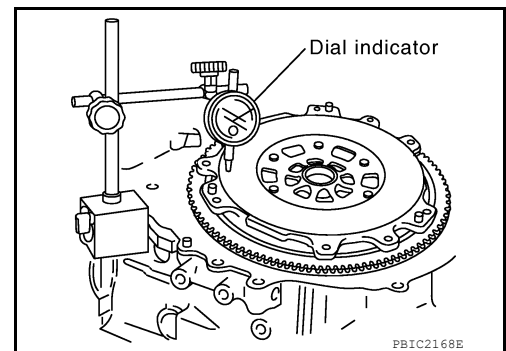

INFOID:000000006251293

## 6M/T : Adjustment after Installation

### ADJUSTMENT AFTER INSTALLATION

With the clutch cover installed on the vehicle, check the diaphragm spring toe height for unevenness. If unevenness exceeds the limit, adjust the diaphragm spring toe height using Tool.

**Uneven limit of diaphragm spring toe height** : Refer to [CL-25, "Clutch Cover"](#).

**Tool number** : ST20050240 ( — )

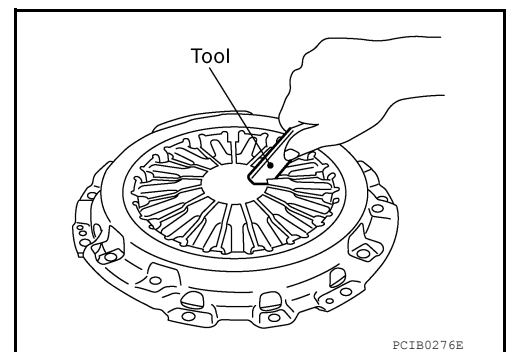



# SERVICE DATA AND SPECIFICATIONS (SDS)

< SERVICE DATA AND SPECIFICATIONS (SDS)

## SERVICE DATA AND SPECIFICATIONS (SDS)

### SERVICE DATA AND SPECIFICATIONS (SDS)

#### Clutch Control System

INFOID:000000006251294

Type of clutch control	Hydraulic
------------------------	-----------

#### Clutch Master Cylinder

INFOID:000000006251295

Unit: mm (in)

Inner diameter	15.87 (5/8)
----------------	-------------

#### Clutch Operating Cylinder

INFOID:000000006251296

Unit: mm (in)

Inner diameter	19.05 (3/4)
----------------	-------------

#### Clutch Disc

INFOID:000000006251297

Unit: mm (in)

	QR25DE	VQ40DE
Engine model	QR25DE	VQ40DE
Model	240	260
Transmission Model	5 M/T	6 M/T
Facing size (Outer dia. × inner dia. × thickness)	240 × 160 × 3.5 (9.45 × 6.30 × 0.138)	260 × 190 × 3.2 (10.24 × 7.48 × 0.126)
Wear limit (depth to rivet head)	0.3 (0.012)	
Runout limit/diameter of the area to be measured	0.7 (0.028) or less/230 (9.06) dia.	1.0 (0.039) or less/250 (9.84) dia.
Maximum backlash of spline (at outer disc edge)	1.0 (0.039)	

#### Clutch Cover

INFOID:000000006251298

Unit: mm (in)

	QR25DE	VQ40DE
Engine model	QR25DE	VQ40DE
Transmission Model	5 M/T	6 M/T
Set-load	5890 N (600 kg, 1324 lb)	8340 N (850 kg, 1875 lb)
Diaphragm spring lever height	37.0 - 39.0 (1.457 - 1.535)	44.0 - 46.0 (1.732 - 1.811)
Uneven limit of diaphragm spring toe height	0.7 (0.028)	

# SERVICE DATA AND SPECIFICATIONS (SDS)

< SERVICE DATA AND SPECIFICATIONS (SDS)

## Clutch Pedal

INFOID:000000006251299

Unit: mm (in)

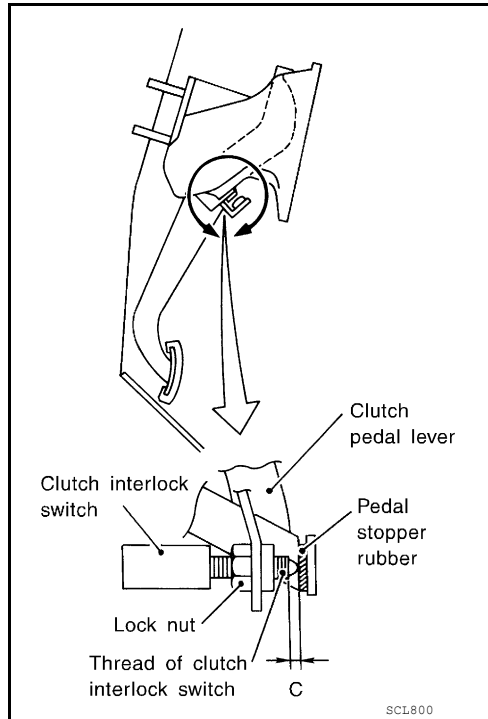

Clearance (C) between pedal stopper rubber and clutch interlock switch threaded end while clutch pedal is fully depressed.

0.1 - 1.0 (0.004 - 0.039)