

SECTION **ACC**  
ACCELERATOR CONTROL SYSTEM

A

ACC

C

D

E

CONTENTS

<b>PRECAUTION</b> .....	2	Component .....	3	F
<b>PRECAUTIONS</b> .....	2	Removal and Installation .....	3	
Precaution for Supplemental Restraint System (SRS) "AIR BAG" and "SEAT BELT PRE-TENSIONER" .....	2	<b>SERVICE DATA AND SPECIFICATIONS (SDS)</b> .....	5	G
<b>UNIT REMOVAL AND INSTALLATION</b> .....	3	<b>SERVICE DATA AND SPECIFICATIONS (SDS)</b> .....	5	H
<b>ACCELERATOR CONTROL SYSTEM</b> .....	3	Accelerator Control .....	5	I

H

I

J

K

L

M

N

O

P

# PRECAUTIONS

< PRECAUTION >

## PRECAUTION

### PRECAUTIONS

#### Precaution for Supplemental Restraint System (SRS) "AIR BAG" and "SEAT BELT PRE-TENSIONER"

INFOID:000000007322514

The Supplemental Restraint System such as "AIR BAG" and "SEAT BELT PRE-TENSIONER", used along with a front seat belt, helps to reduce the risk or severity of injury to the driver and front passenger for certain types of collision. This system includes seat belt switch inputs and dual stage front air bag modules. The SRS system uses the seat belt switches to determine the front air bag deployment, and may only deploy one front air bag, depending on the severity of a collision and whether the front occupants are belted or unbelted. Information necessary to service the system safely is included in the SR and SB section of this Service Manual.

#### **WARNING:**

- To avoid rendering the SRS inoperative, which could increase the risk of personal injury or death in the event of a collision which would result in air bag inflation, all maintenance must be performed by an authorized NISSAN/INFINITI dealer.
- Improper maintenance, including incorrect removal and installation of the SRS, can lead to personal injury caused by unintentional activation of the system. For removal of Spiral Cable and Air Bag Module, see the SR section.
- Do not use electrical test equipment on any circuit related to the SRS unless instructed to in this Service Manual. SRS wiring harnesses can be identified by yellow and/or orange harnesses or harness connectors.

#### PRECAUTIONS WHEN USING POWER TOOLS (AIR OR ELECTRIC) AND HAMMERS

#### **WARNING:**

- When working near the Airbag Diagnosis Sensor Unit or other Airbag System sensors with the Ignition ON or engine running, DO NOT use air or electric power tools or strike near the sensor(s) with a hammer. Heavy vibration could activate the sensor(s) and deploy the air bag(s), possibly causing serious injury.
- When using air or electric power tools or hammers, always switch the Ignition OFF, disconnect the battery, and wait at least 3 minutes before performing any service.

# ACCELERATOR CONTROL SYSTEM

< UNIT REMOVAL AND INSTALLATION >

## UNIT REMOVAL AND INSTALLATION

### ACCELERATOR CONTROL SYSTEM

Component

INFOID:000000007322515

A

ACC

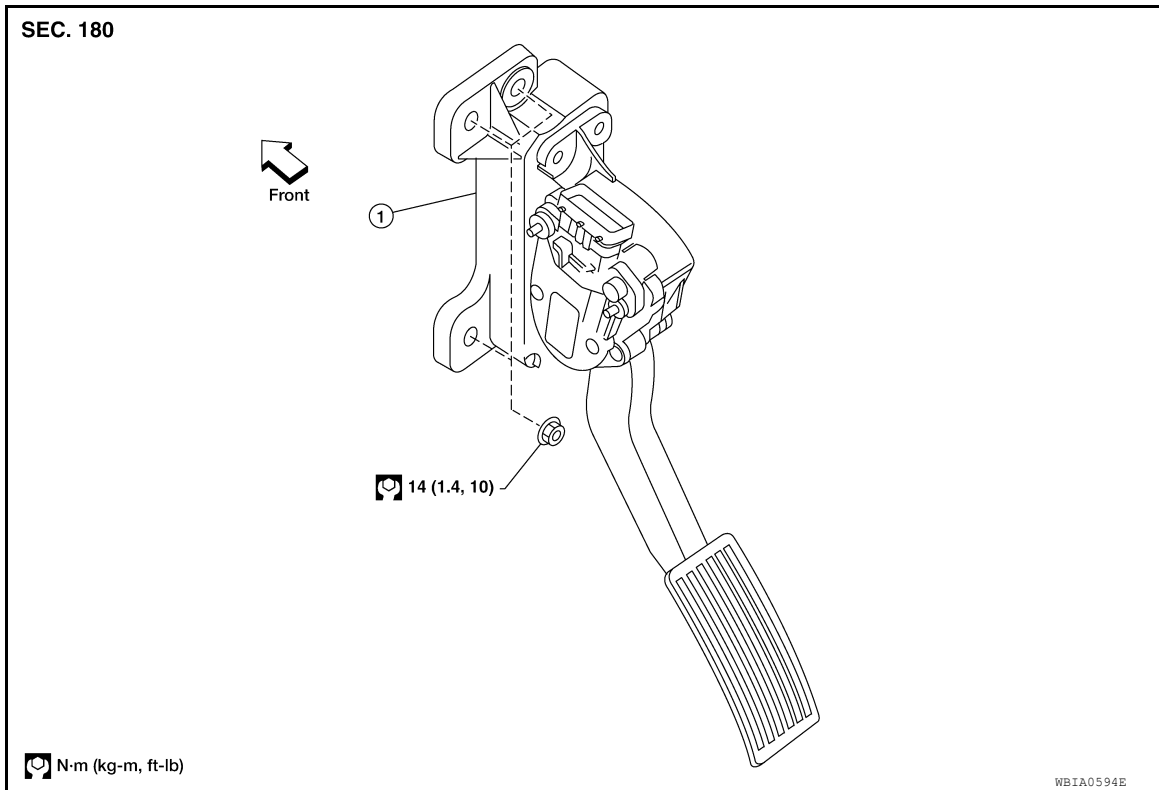

C

D

E

F

G

H

I

J

1. Accelerator pedal assembly

#### CAUTION:

- Do not disassemble the accelerator pedal assembly.
- Do not remove the accelerator pedal position sensor from the accelerator pedal bracket.
- Avoid damage from dropping the accelerator pedal assembly during handling.
- Keep the accelerator pedal assembly away from water.

### Removal and Installation

INFOID:000000007322516

#### REMOVAL

1. Disconnect the negative battery terminal. Refer to [PG-80, "Removal and Installation"](#).
2. Disconnect the accelerator position sensor electrical connector.
  - a. Pull the connector lock back to unlock the connector from the accelerator pedal position sensor as shown.
  - b. Pull up on the connector to disconnect it from the accelerator pedal position sensor as shown.
3. Remove the two upper and one lower accelerator pedal nuts.
4. Remove the accelerator pedal assembly.

#### CAUTION:

- Do not disassemble the accelerator pedal assembly.
- Do not remove the accelerator pedal position sensor from the accelerator pedal bracket.
- Avoid damage from dropping the accelerator pedal assembly during handling.
- Keep the accelerator pedal assembly away from water.

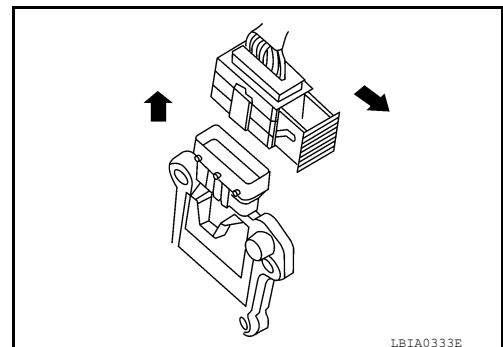

K

L

M

N

O

P

# ACCELERATOR CONTROL SYSTEM

< UNIT REMOVAL AND INSTALLATION >

## INSTALLATION

Installation is in the reverse order of removal.

## INSPECTION AFTER INSTALLATION

- Check that the accelerator pedal moves smoothly within the specified range.

**Accelerator pedal - total : Refer to [ACC-5, "Accelerator pedal applied stroke \(A\) Control"](#).**

- Check that the accelerator pedal smoothly returns to the original position.
- Perform an electrical inspection of the accelerator pedal position sensor. Refer to [EC-227, "Component Inspection"](#) (QR25DE), [EC-700, "Component Inspection"](#) (VQ40DE).

### CAUTION:

When the harness connector of the accelerator pedal position sensor is disconnected, perform "Accelerator Pedal Released Position Learning". Refer to [EC-109, "Accelerator Pedal Released Position Learning"](#) (QR25DE), [EC-563, "Accelerator Pedal Released Position Learning"](#) (VQ40DE).

### CAUTION:

If equipped with VDC, reset the steering angle sensor calibration. Refer to [BRC-12, "ADJUSTMENT OF STEERING ANGLE SENSOR NEUTRAL POSITION : Special Repair Requirement"](#) (Type 1) or [BRC-122, "ADJUSTMENT OF STEERING ANGLE SENSOR NEUTRAL POSITION : Special Repair Requirement"](#) (Type 2).

### CAUTION:

When the harness connector of the accelerator pedal position sensor is disconnected, perform "Accelerator Pedal Released Position Learning". Refer to [EC-109, "Accelerator Pedal Released Position Learning"](#) (QR25DE), [EC-563, "Accelerator Pedal Released Position Learning"](#) (VQ40DE).

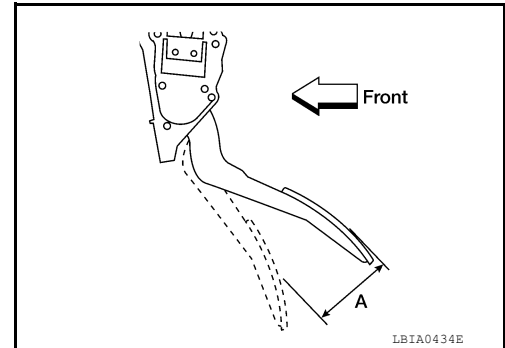

# SERVICE DATA AND SPECIFICATIONS (SDS)

< SERVICE DATA AND SPECIFICATIONS (SDS)

## SERVICE DATA AND SPECIFICATIONS (SDS)

SERVICE DATA AND SPECIFICATIONS (SDS)

Accelerator Control

INFOID:000000007322517

A

ACC

ACCELERATOR PEDAL

Unit: mm (in)

C

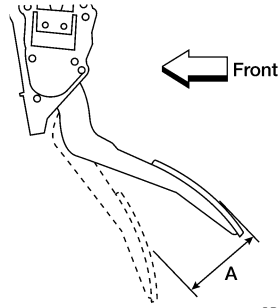

D

E

F

Accelerator pedal - total pedal applied stroke (A)	48 (1.89)
--	-----------

G

H

I

J

K

L

M

N

O

P