

A  
CO  
C  
D  
E  
F  
G  
H  
I  
J  
K  
L  
M  
N  
O  
P

# SECTION CO

## ENGINE COOLING SYSTEM

### CONTENTS

<p style="text-align: center;"><b>QR25DE</b></p> <p><b>PRECAUTION</b> ..... 3</p> <p><b>PRECAUTIONS</b> ..... 3</p> <p style="padding-left: 20px;">Precaution for Supplemental Restraint System (SRS) "AIR BAG" and "SEAT BELT PRE-TENSIONER" ..... 3</p> <p style="padding-left: 20px;">Precaution for Liquid Gasket ..... 3</p> <p><b>PREPARATION</b> ..... 5</p> <p><b>PREPARATION</b> ..... 5</p> <p style="padding-left: 20px;">Special Service Tool ..... 5</p> <p style="padding-left: 20px;">Commercial Service Tool ..... 5</p> <p><b>SYSTEM DESCRIPTION</b> ..... 7</p> <p><b>COOLING SYSTEM</b> ..... 7</p> <p style="padding-left: 20px;">Cooling Circuit ..... 7</p> <p style="padding-left: 20px;">Schematic ..... 8</p> <p><b>OVERHEATING CAUSE ANALYSIS</b> ..... 9</p> <p style="padding-left: 20px;">Troubleshooting Chart ..... 9</p> <p><b>PERIODIC MAINTENANCE</b> ..... 11</p> <p><b>ENGINE COOLANT</b> ..... 11</p> <p style="padding-left: 20px;">System Inspection ..... 11</p> <p style="padding-left: 20px;">Changing Engine Coolant ..... 12</p> <p><b>REMOVAL AND INSTALLATION</b> ..... 16</p> <p><b>RADIATOR</b> ..... 16</p> <p style="padding-left: 20px;">Exploded View ..... 16</p> <p style="padding-left: 20px;">Removal and Installation ..... 16</p> <p><b>COOLING FAN</b> ..... 19</p> <p style="padding-left: 20px;">Exploded View ..... 19</p> <p style="padding-left: 20px;">Removal and Installation (Crankshaft driven type)... 19</p> <p><b>WATER PUMP</b> ..... 21</p> <p style="padding-left: 20px;">Exploded View ..... 21</p>	<p style="padding-left: 20px;">Removal and Installation ..... 21</p> <p><b>THERMOSTAT AND THERMOSTAT HOUSING</b> ..... 23</p> <p style="padding-left: 20px;">Exploded View ..... 23</p> <p style="padding-left: 20px;">Removal and Installation Thermostat ..... 23</p> <p style="padding-left: 20px;">Removal and Installation Thermostat Housing ..... 24</p> <p><b>WATER CONTROL VALVE</b> ..... 26</p> <p style="padding-left: 20px;">Exploded View ..... 26</p> <p style="padding-left: 20px;">Removal and Installation ..... 26</p> <p><b>WATER OUTLET AND WATER PIPING</b> ..... 28</p> <p style="padding-left: 20px;">Exploded View ..... 28</p> <p style="padding-left: 20px;">Removal and Installation ..... 28</p> <p><b>SERVICE DATA AND SPECIFICATIONS (SDS)</b> ..... 30</p> <p><b>SERVICE DATA AND SPECIFICATIONS (SDS)</b> ..... 30</p> <p style="padding-left: 20px;">Standard and Limit ..... 30</p> <p style="text-align: center;"><b>VQ40DE</b></p> <p><b>PRECAUTION</b> ..... 31</p> <p><b>PRECAUTIONS</b> ..... 31</p> <p style="padding-left: 20px;">Precaution for Supplemental Restraint System (SRS) "AIR BAG" and "SEAT BELT PRE-TENSIONER" ..... 31</p> <p style="padding-left: 20px;">Precaution for Liquid Gasket ..... 31</p> <p><b>PREPARATION</b> ..... 33</p> <p><b>PREPARATION</b> ..... 33</p> <p style="padding-left: 20px;">Special Service Tool ..... 33</p> <p style="padding-left: 20px;">Commercial Service Tool ..... 33</p> <p><b>SYSTEM DESCRIPTION</b> ..... 35</p> <p><b>COOLING SYSTEM</b> ..... 35</p> <p style="padding-left: 20px;">Cooling Circuit ..... 35</p>
---	---

Schematic .....	36	<b>WATER PUMP .....</b>	<b>50</b>
<b>OVERHEATING CAUSE ANALYSIS .....</b>	<b>37</b>	Exploded View .....	50
Troubleshooting Chart .....	37	Removal and Installation .....	50
<b>PERIODIC MAINTENANCE .....</b>	<b>39</b>	<b>WATER INLET AND THERMOSTAT ASSEMBLY .....</b>	<b>55</b>
<b>ENGINE COOLANT .....</b>	<b>39</b>	Exploded View .....	55
System Inspection .....	39	Removal and Installation .....	55
Changing Engine Coolant .....	40	<b>WATER OUTLET AND WATER PIPING .....</b>	<b>57</b>
<b>REMOVAL AND INSTALLATION .....</b>	<b>44</b>	Exploded View .....	57
<b>RADIATOR .....</b>	<b>44</b>	Removal and Installation .....	57
Exploded View .....	44	<b>SERVICE DATA AND SPECIFICATIONS (SDS) .....</b>	<b>59</b>
Removal and Installation .....	44	<b>SERVICE DATA AND SPECIFICATIONS (SDS) .....</b>	<b>59</b>
<b>ENGINE COOLING FAN .....</b>	<b>47</b>	Standard and Limit .....	59
Exploded View .....	47		
Removal and Installation (Crankshaft driven type) ..	47		
Removal and Installation (Motor driven type) .....	48		

PRECAUTION

PRECAUTIONS

Precaution for Supplemental Restraint System (SRS) "AIR BAG" and "SEAT BELT PRE-TENSIONER"

INFOID:000000007323352

The Supplemental Restraint System such as "AIR BAG" and "SEAT BELT PRE-TENSIONER", used along with a front seat belt, helps to reduce the risk or severity of injury to the driver and front passenger for certain types of collision. This system includes seat belt switch inputs and dual stage front air bag modules. The SRS system uses the seat belt switches to determine the front air bag deployment, and may only deploy one front air bag, depending on the severity of a collision and whether the front occupants are belted or unbelted. Information necessary to service the system safely is included in the SR and SB section of this Service Manual.

**WARNING:**

- To avoid rendering the SRS inoperative, which could increase the risk of personal injury or death in the event of a collision which would result in air bag inflation, all maintenance must be performed by an authorized NISSAN/INFINITI dealer.
- Improper maintenance, including incorrect removal and installation of the SRS, can lead to personal injury caused by unintentional activation of the system. For removal of Spiral Cable and Air Bag Module, see the SR section.
- Do not use electrical test equipment on any circuit related to the SRS unless instructed to in this Service Manual. SRS wiring harnesses can be identified by yellow and/or orange harnesses or harness connectors.

PRECAUTIONS WHEN USING POWER TOOLS (AIR OR ELECTRIC) AND HAMMERS

**WARNING:**

- When working near the Airbag Diagnosis Sensor Unit or other Airbag System sensors with the Ignition ON or engine running, DO NOT use air or electric power tools or strike near the sensor(s) with a hammer. Heavy vibration could activate the sensor(s) and deploy the air bag(s), possibly causing serious injury.
- When using air or electric power tools or hammers, always switch the Ignition OFF, disconnect the battery, and wait at least 3 minutes before performing any service.

Precaution for Liquid Gasket

INFOID:000000007323353

REMOVAL OF LIQUID GASKET

- After removing the bolts and nuts, separate the mating surface and remove the old liquid gasket using Tool.

Tool number : KV10111100 (J-37228)

**CAUTION:**

Do not damage the mating surfaces.

- Tap the seal cutter to insert it (1).
- In areas where the Tool is difficult to use, lightly tap to slide it (2).

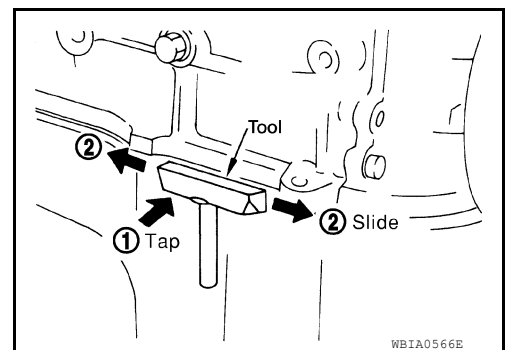

LIQUID GASKET APPLICATION PROCEDURE

A  
CO  
C  
D  
E  
F  
G  
H  
I  
J  
K  
L  
M  
N  
O  
P

# PRECAUTIONS

[QR25DE]

## < PRECAUTION >

1. Remove the old liquid gasket adhering to the gasket application surface and the mating surface using suitable tool.
  - Remove the liquid gasket completely from the groove of the liquid gasket application surface, bolts, and bolt holes.
2. Thoroughly clean the mating surfaces and remove adhering moisture, grease and foreign material.

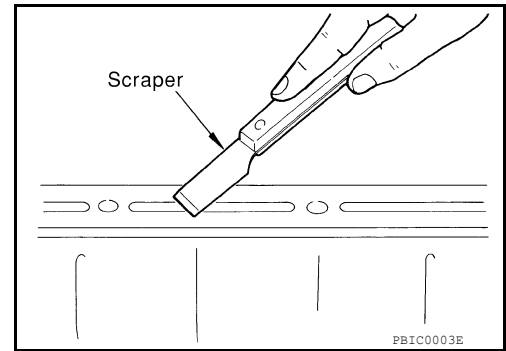

3. Attach the liquid gasket tube to the Tool.

**Tool number** : WS39930000 ( — )

**Use Genuine RTV Silicone Sealant or equivalent. Refer to [GI-22, "Recommended Chemical Products and Sealants"](#).**

4. Apply the liquid gasket without breaks to the specified location with the specified dimensions.

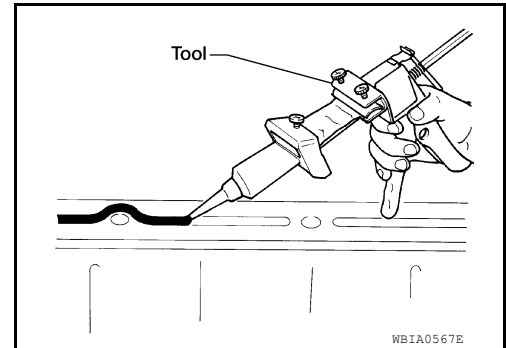

- If there is a groove for the liquid gasket application, apply the liquid gasket to the groove.
- Normally apply the liquid gasket on the inside edge of the bolt holes. Also apply to the outside edge of the bolt holes when specified in the procedure.
- Within five minutes of liquid gasket application, install the mating component.
- If the liquid gasket protrudes, wipe it off immediately.
- Do not retighten after the installation.
- Wait 30 minutes or more after installation before refilling the engine with oil or coolant.

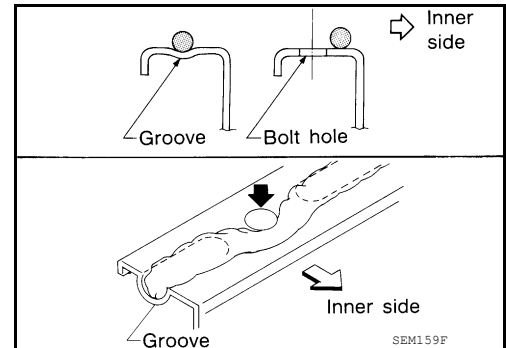

### **CAUTION:**

**Carefully follow all of the warnings, cautions, notes, and procedures contained in this manual.**

# PREPARATION

< PREPARATION >

[QR25DE]

## PREPARATION

### PREPARATION

#### Special Service Tool

INFOID:000000007323354

A

CO

The actual shapes of Kent-Moore tools may differ from those of special service tools illustrated here.

Tool number (Kent-Moore No.) Tool name	Description
KV10111100 (J-37228) Seal cutter	Removing chain tensioner cover and water pump cover
WS39930000 ( — ) Tube presser	Pressing the tube of liquid gasket
EG17650301 (J-33984-A) Radiator cap tester adapter	Adapting radiator cap tester to radiator cap and radiator filler neck <b>a: 28 (1.10) dia.</b> <b>b: 31.4 (1.236) dia.</b> <b>c: 41.3 (1.626) dia.</b> Unit: mm (in)
KV991J0070 (J-45695) Coolant refill tool	Filling cooling system
KV991J0010 (J-23688) Engine coolant refractometer	Checking concentration of ethylene glycol in engine coolant

C

D

E

F

G

H

I

J

K

L

M

N

O

P

#### Commercial Service Tool

INFOID:000000007323355

# PREPARATION

< PREPARATION >

[QR25DE]

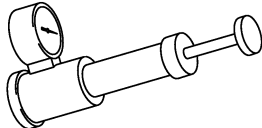
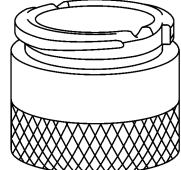
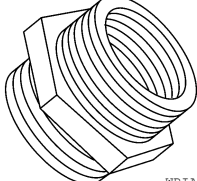
Tool name	Description
<p data-bbox="159 195 272 222">Power tool</p>  <p data-bbox="824 415 901 432">PIIB1407E</p>	<p data-bbox="1003 195 1344 222">Loosening nuts, screws and bolts</p>
<p data-bbox="159 447 354 474">Radiator cap tester</p>  <p data-bbox="824 667 901 684">PBIC1982E</p>	<p data-bbox="1003 447 1360 474">Checking radiator and radiator cap</p>
<p data-bbox="159 699 467 726">Coolant system tester adapter</p>  <p data-bbox="824 919 901 936">WBIA0408E</p>	<p data-bbox="1003 699 1458 753">Adapting radiator cap tester to reservoir filler neck</p>
<p data-bbox="159 951 467 978">Coolant system tester adapter</p>  <p data-bbox="824 1171 901 1188">WBIA0409E</p>	<p data-bbox="1003 951 1458 978">Adapting radiator cap tester to reservoir cap</p>

# COOLING SYSTEM

< SYSTEM DESCRIPTION >

[QR25DE]

## SYSTEM DESCRIPTION

### COOLING SYSTEM

#### Cooling Circuit

INFOID:000000007323356

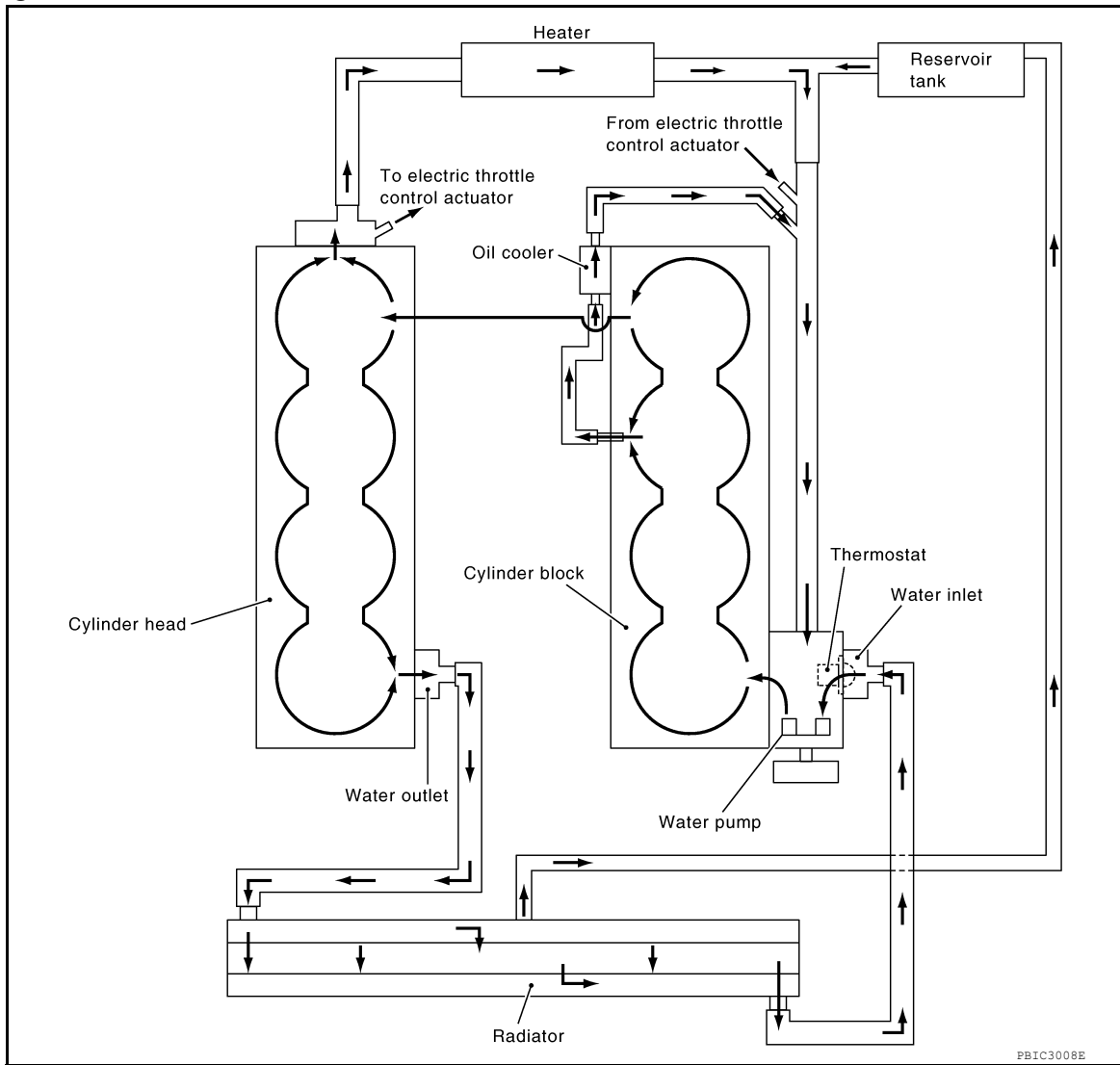

A

CO

C

D

E

F

G

H

I

J

K

L

M

N

O

P

# COOLING SYSTEM

< SYSTEM DESCRIPTION >

[QR25DE]

## Schematic

INFOID:000000007323357

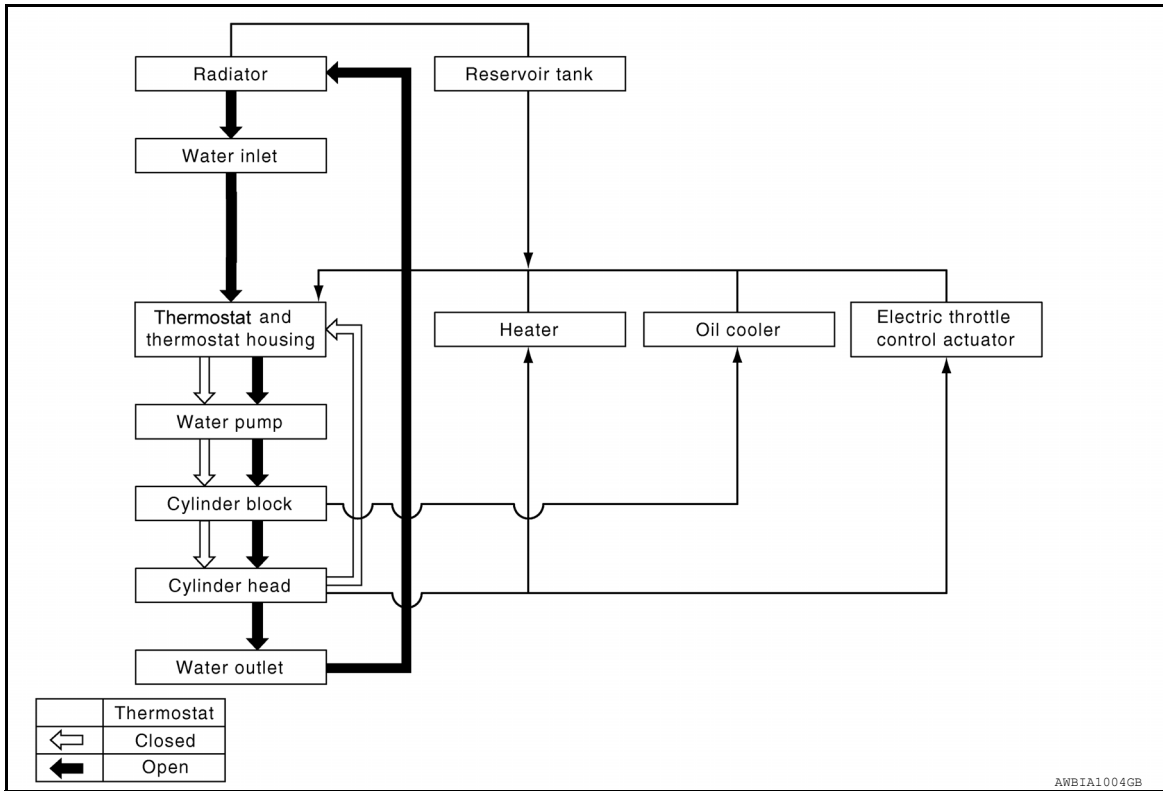



# OVERHEATING CAUSE ANALYSIS

< SYSTEM DESCRIPTION >

[QR25DE]

## OVERHEATING CAUSE ANALYSIS

### Troubleshooting Chart

INFOID:000000007323358

	Symptom		Check items			
Cooling system parts malfunction	Poor heat transfer	Water pump malfunction	Worn or loose drive belt	—	A	
		Thermostat or water control valve stuck closed	Thermostat or water control valve		C	
		Damaged fins	Dust contamination or paper clogging		D	
			Physical damage		E	
	Reduced air flow	Clogged radiator cooling tube	Excess foreign material (rust, dirt, sand, etc.)	—	F	
		Cooling fan does not operate	Fan assembly		G	
		High resistance to fan rotation			H	
		Damaged fan blades			I	
		Damaged radiator shroud	—	Radiator shroud	—	J
		Improper engine coolant mixture ratio	—	Engine coolant viscosity	—	K
		Poor engine coolant quality	—		—	L
	Insufficient engine coolant	Engine coolant leaks	Cooling hose	Loose clamp	—	M
				Cracked hose		N
			Water pump	Poor sealing	O	
				Radiator or reservoir cap	Loose	P
Poor sealing			Q			
Radiator			O-ring for damage, deterioration or improper fitting	R		
		Cracked radiator tank	S			
		Cracked radiator core	T			
	Reservoir tank	Cracked reservoir tank	U			
Overflowing reservoir tank	Exhaust gas leaks into cooling system	Cylinder head deterioration	V			
		Cylinder head gasket deterioration	W			

CO

# OVERHEATING CAUSE ANALYSIS

< SYSTEM DESCRIPTION >

[QR25DE]

	Symptom		Check items			
Except cooling system parts malfunction	—	Overload on engine	Abusive driving	High engine rpm under no load		
				Driving in low gear for extended time		
				Driving at extremely high speed		
			Powertrain system malfunction	—		
			Installed improper size wheels and tires			
			Dragging brakes			
	Improper ignition timing					
	Blocked or restricted air flow	Blocked bumper	Blocked radiator grille	Mud contamination or paper clogging	—	
				Installed car brassiere		
			Blocked radiator Blocked condenser Installed large fog lamp	Mud contamination or paper clogging		
				Blocked air flow		

## PERIODIC MAINTENANCE

### ENGINE COOLANT

#### System Inspection

INFOID:000000007323359

#### **WARNING:**

- Never remove the radiator cap or reservoir tank cap when the engine is hot. Serious burns could occur from high pressure fluid escaping from the radiator or reservoir.
- Wrap a thick cloth around the cap. Slowly push down and turn it a quarter turn to allow built-up pressure to escape. Carefully remove the cap by pushing down and turning it all the way.

#### CHECKING COOLING SYSTEM HOSES

Check hoses for the following:

- Improper attachment
- Leaks
- Cracks
- Damage
- Loose connections
- Chafing
- Deterioration

#### CHECKING RESERVOIR LEVEL

- Check if the engine coolant reservoir tank level is within MIN to MAX when the engine is cool.
- Adjust engine coolant level as necessary.

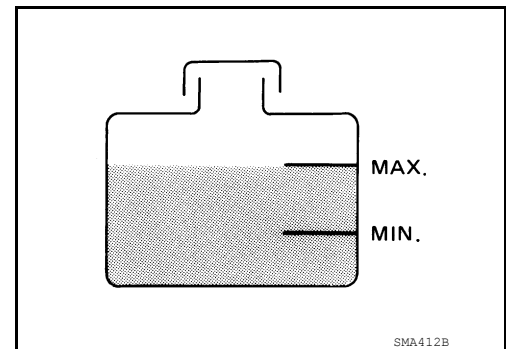

#### CHECKING COOLING SYSTEM FOR LEAKS

#### **WARNING:**

Never remove the radiator cap or reservoir cap when the engine is hot. Serious burns could occur from high pressure coolant escaping from the radiator or reservoir.

- To check for leakage, apply pressure to the cooling system at the reservoir filler neck using suitable tool and Tool.

**Tool number** : EG17650301 (J-33984-A)

**Testing pressure** : 156 kPa (1.6 kg/cm<sup>2</sup>, 23 psi)

#### **CAUTION:**

Higher pressure than specified may cause radiator damage.

#### **NOTE:**

In case that engine coolant decreases, replenish cooling system with engine coolant.

- If any concerns are found, repair or replace damaged parts.

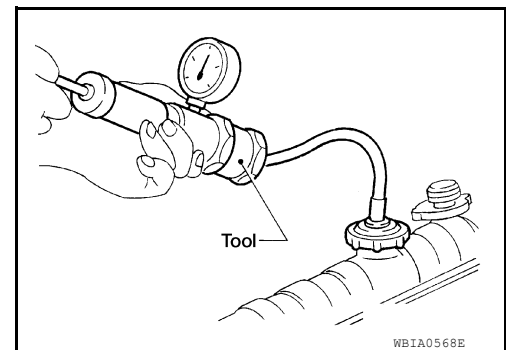

#### CHECKING RESERVOIR CAP

1. Inspect the reservoir cap.
  - Replace the cap if the metal plunger cannot be seen around the edge of the black rubber gasket.
  - Replace the cap if deposits of waxy residue or other foreign material are on the black rubber gasket or the metal retainer.

#### **NOTE:**

Thoroughly wipe out the reservoir filler neck to remove any waxy residue or foreign material.

# ENGINE COOLANT

[QR25DE]

## < PERIODIC MAINTENANCE >

2. Pull the negative-pressure valve to open it and check that it closes completely when released.
  - Check that there is no dirt or damage on the valve seat of the reservoir cap negative-pressure valve.
  - Check that there are no abnormalities in the opening and closing conditions of the negative-pressure valve.

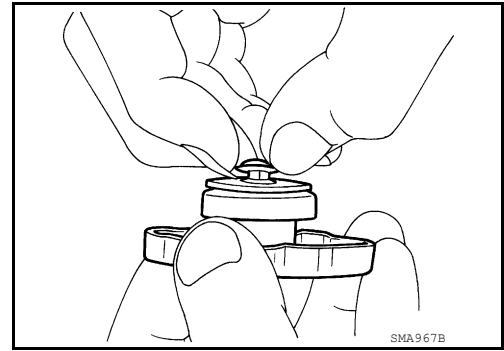

3. Check reservoir cap relief pressure using suitable tool and Tool.

**Tool number** : EG17650301 (J-33984-A)

**Standard:** 98 – 118 kPa (1.0 – 1.2 kg/cm<sup>2</sup>, 14 – 17 psi)

### NOTE:

- Apply engine coolant to the cap seal surface.
- Replace the reservoir cap if there is any damage in the negative-pressure valve, or if the open-valve pressure is outside of the limit.

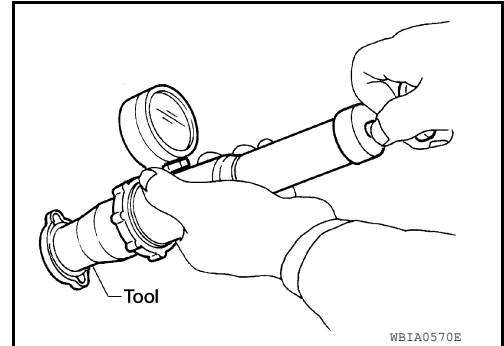

## CHECKING RADIATOR CAP

Inspect the radiator cap.

### NOTE:

Thoroughly wipe out the radiator filler neck to remove any waxy residue or foreign material.

- Replace the cap if deposits of waxy residue or other foreign material are on the black rubber gasket or the metal retainer.

## CHECKING RADIATOR

Check radiator for mud or clogging. If necessary, clean radiator as follows.

### CAUTION:

- **Be careful not to bend or damage the radiator fins.**
  - **When radiator is cleaned without removal, remove all surrounding parts such as cooling fan shroud and horns. Then tape the harness and electrical connectors to prevent water from entering.**
1. Spray water to the back side of the radiator core using a side to side motion from the top down.
  2. Stop spraying when debris no longer flows from radiator core.
  3. Blow air into the back side of radiator core using a side to side motion from the top down.
    - Use compressed air lower than 490 kPa (5 kg/cm<sup>2</sup>, 71 psi) and keep distance more than 30 cm (11.8 in).
  4. Continue to blow air until no water sprays out.
  5. Check for coolant leaks. Repair as necessary.

## Changing Engine Coolant

INFOID:000000007323360

### WARNING:

- **To avoid being scalded, never change the coolant when the engine is hot.**
- **Wrap a thick cloth around the cap to carefully remove the cap. First, turn the cap a quarter of a turn to release any built-up pressure, then push down and turn the cap all the way to remove it.**
- **Avoid direct skin contact with used coolant. If skin contact is made, wash thoroughly with soap or hand cleaner as soon as possible.**
- **Keep coolant out of the reach of children and pets.**

## DRAINING ENGINE COOLANT

1. Turn ignition switch ON and set temperature control lever all the way to HOT position or the highest temperature position. Wait 10 seconds and turn ignition switch OFF.
2. Remove the engine under cover. Refer to [EXT-15, "Removal and Installation"](#).

# ENGINE COOLANT

[QR25DE]

## < PERIODIC MAINTENANCE >

3. Open the radiator drain plug at the bottom of the radiator, and remove the reservoir cap. This is the only step required when partially draining the cooling system (radiator only).

**CAUTION:**

- Do not allow the coolant to contact the drive belts.
- Perform this step when engine is cold.

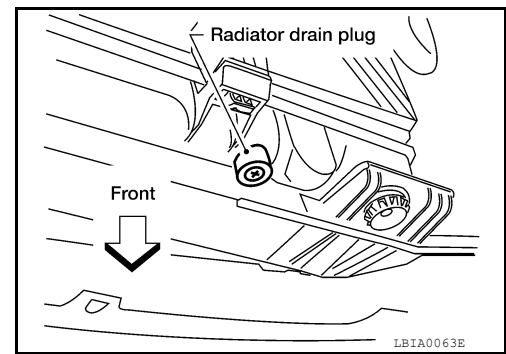

4. Follow this step for heater core removal/replacement only. Disconnect the upper heater hose at the engine side and apply moderate air pressure [103.46 kPa (15 psi, 1.055 kg/cm<sup>2</sup>) maximum air pressure] into the hose for 30 seconds to blow the excess coolant out of the heater core.

5. When draining all of the coolant in the system for engine removal or repair, it is necessary to drain the cylinder block. Remove the cylinder block drain plug or block heater (if equipped), to drain the cylinder block as shown.

**CAUTION:**

**Do not reuse copper sealing washers.**

**NOTE:**

For Canada, the cylinder block drain plug as shown, is not a cylinder block drain plug but a block heater.

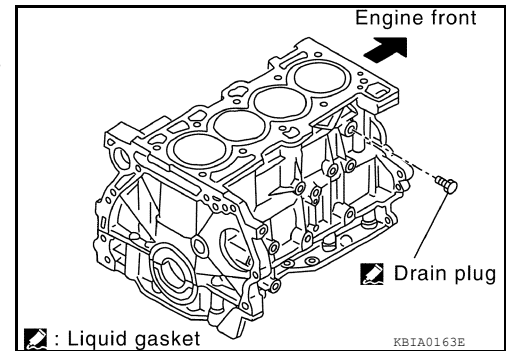

6. Remove the reservoir tank to drain the engine coolant, then clean the reservoir tank before installing it.
7. Check the drained coolant for contaminants such as rust, corrosion or discoloration. If the coolant is contaminated, flush the engine cooling system. Follow the "Flushing Cooling System" procedure.

## REFILLING ENGINE COOLANT

1. Close the radiator drain plug. Install the reservoir tank and cylinder block drain plug and block heater (if equipped).

**CAUTION:**

**Do not reuse copper sealing washers.**

- The radiator must be completely empty of coolant and water.
- Apply sealant to the threads of the cylinder block drain plugs.
- **Use Genuine High Performance Thread Sealant or equivalent. Refer to [GI-22. "Recommended Chemical Products and Sealants"](#).**
- Tighten each plug to the specified torque.

**Radiator drain plug** : Refer to [CO-16](#).

**Cylinder block drain plug** : Refer to [EM-80](#).

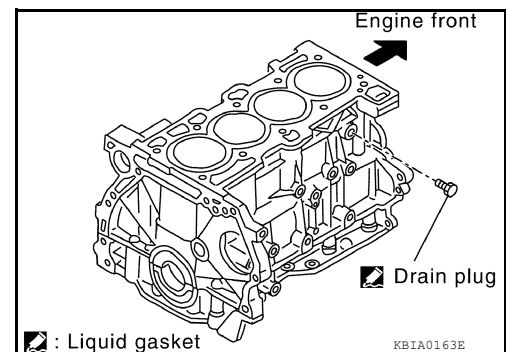

2. Set the vehicle heater controls to the full HOT and heater ON position. Turn the vehicle ignition ON with the engine OFF as necessary to activate the heater mode.
3. Remove the vented reservoir cap and replace it with a non-vented reservoir cap before filling the cooling system.

# ENGINE COOLANT

[QR25DE]

## < PERIODIC MAINTENANCE >

4. Install the Tool by installing the radiator cap adapter onto the radiator neck opening. Then attach the gauge body assembly with the refill tube and the venturi assembly to the radiator cap adapter.

**Tool number** : KV991J0070 (J-45695)

5. Insert the refill hose into the coolant mixture container that is placed at floor level. Make sure the ball valve is in the closed position.

**CAUTION:**

**Do not use any cooling system additives such as radiator sealer. Additives may clog the cooling system and cause damage to the engine, transmission and/or cooling system.**

**NOTE:**

Use recommended coolant or equivalent. Refer to [MA-18, "FOR USA AND CANADA : Fluids and Lubricants"](#) (United States and Canada).

**Cooling system capacity (with reservoir)** : Refer to [CO-30, "Standard and Limit"](#).

6. Install an air hose to the venturi assembly, the air pressure must be within specification.

**Compressed air supply pressure** : 549 - 824 kPa (5.6 - 8.4 kg/cm<sup>2</sup>, 80 - 119 psi)

**CAUTION:**

**The compressed air supply must be equipped with an air dryer.**

7. The vacuum gauge will begin to rise and there will be an audible hissing noise. During this process open the ball valve on the refill hose slightly. Rising coolant will be visible in the refill hose. After the refill hose is full of coolant, close the ball valve. This will purge air trapped in the refill hose.

8. Continue to draw the vacuum until the gauge reaches 28 inches of vacuum. The gauge may not reach 28 inches in high altitude locations. Refer to the following table for expected vacuum readings.

Altitude above sea level	Vacuum gauge reading
0 - 100 m (328 ft)	: 28 inches of vacuum
300 m (984 ft)	: 27 inches of vacuum
500 m (1,641 ft)	: 26 inches of vacuum
1,000 m (3,281 ft)	: 24 - 25 inches of vacuum

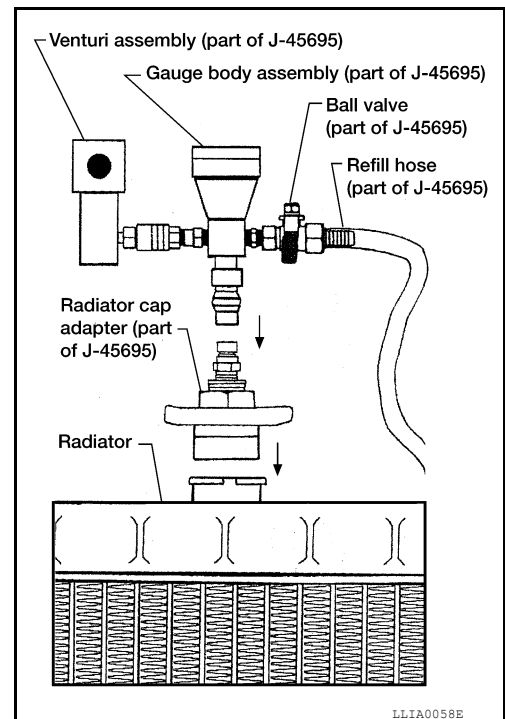

9. When the vacuum gauge has reached the specified amount, disconnect the air hose and wait 20 seconds to see if the system loses vacuum. If the vacuum level drops, perform necessary repairs to the system and repeat steps 6 - 8 to bring the vacuum to the specified amount. Recheck for leaks.
10. Place the coolant container (with the refill hose inserted) at the same level as the top of the radiator. Then open the ball valve on the refill hose so the coolant will be drawn up to fill the cooling system. The cooling system is full when the vacuum gauge reads zero.

**CAUTION:**

**Do not allow the coolant container to get too low when filling, to avoid air from being drawn into the cooling system.**

11. Remove the Tool from the radiator neck opening and install the radiator cap.
12. Remove the non-vented reservoir cap.
13. Fill the cooling system reservoir tank to the specified level. Run the engine to warm up the cooling system and top up the system as necessary before installing the vented reservoir cap.

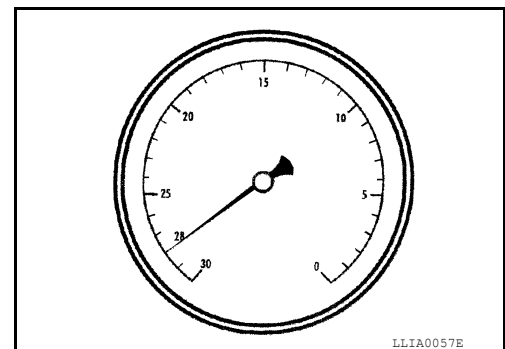

# ENGINE COOLANT

< PERIODIC MAINTENANCE >

[QR25DE]

14. Install the engine under cover. Refer to [EXT-15. "Removal and Installation"](#).

## FLUSHING COOLING SYSTEM

1. Drain the engine coolant from the engine cooling system. Refer to [CO-12. "Changing Engine Coolant"](#).
2. Fill the radiator and the reservoir tank (to the "MAX" line) with water. Reinstall the radiator cap and leave the vented reservoir cap off.
3. Run the engine until it reaches normal operating temperature.
4. Press the engine accelerator two or three times under no-load.
5. Stop the engine and wait until it cools down.
6. Drain the water from the engine cooling system. Refer to [CO-12. "Changing Engine Coolant"](#).
7. Repeat steps 2 through 6 until clear water begins to drain from the radiator.

A

CO

C

D

E

F

G

H

I

J

K

L

M

N

O

P

# RADIATOR

< REMOVAL AND INSTALLATION >

[QR25DE]

## REMOVAL AND INSTALLATION

### RADIATOR

#### Exploded View

INFOID:000000007323361

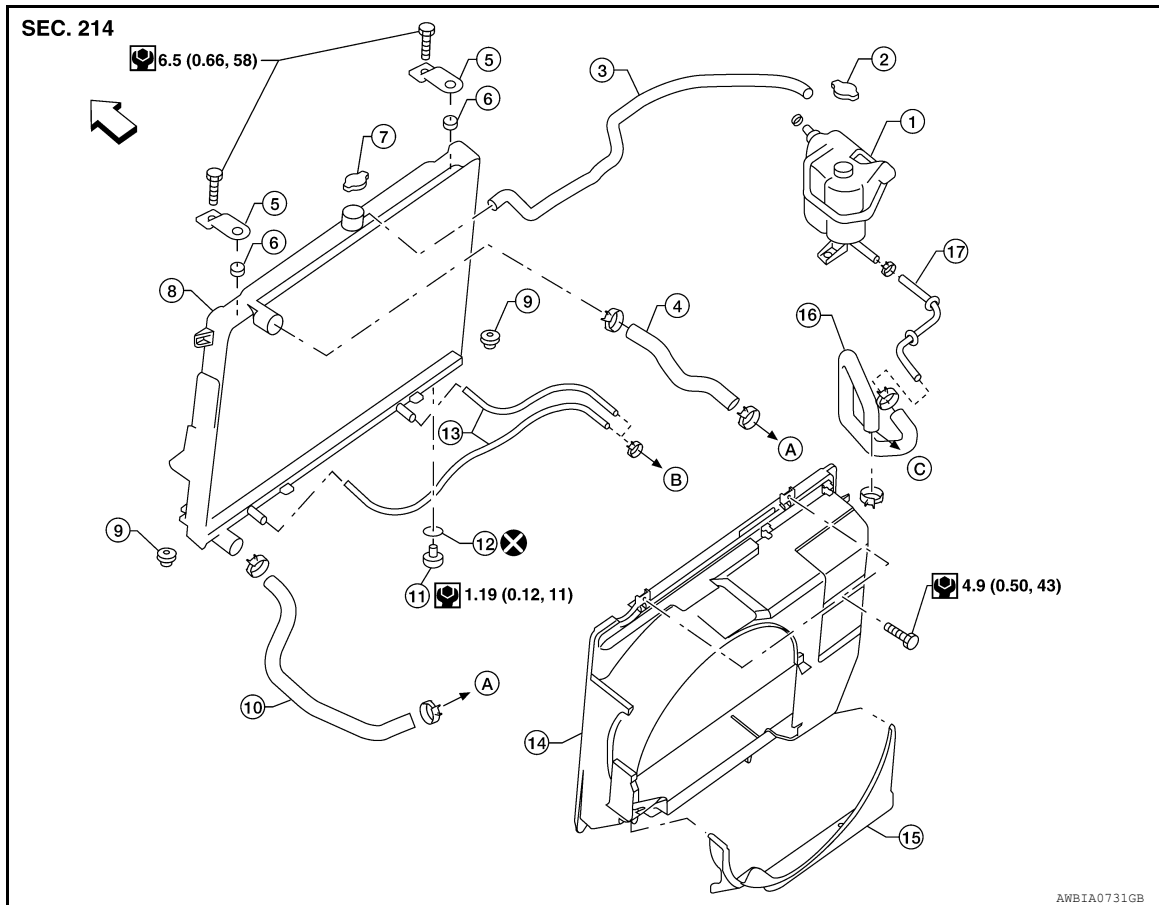

- |   |                         |                            |
|---|-------------------------|----------------------------|
| 1. Reservoir tank                       | 2. Reservoir tank cap   | 3. Reservoir tank hose     |
| 4. Radiator hose (upper)                | 5. Upper mount bracket  | 6. Mounting rubber (upper) |
| 7. Radiator cap                         | 8. Radiator             | 9. Mounting rubber (lower) |
| 10. Radiator hose (lower)               | 11. Radiator drain plug | 12. O-ring                 |
| 13. A/T fluid cooler hose (if equipped) | 14. Upper shroud        | 15. Lower shroud           |
| 16. Heater bypass hose                  | 17. Heater bypass tube  | A. To water inlet          |
| B. To A/T fluid cooler tube             | C. To heater tube       | ⇐ Front                    |

### Removal and Installation

INFOID:000000007323362

#### **WARNING:**

Do not remove radiator cap when engine is hot. Serious burns could occur from high-pressure engine coolant escaping from radiator. Wrap a thick cloth around the cap. Slowly turn it a quarter of a turn to release built-up pressure. Carefully remove radiator cap by turning it all the way.

#### **NOTE:**

When removing components such as hoses, tubes/lines, etc., cap or plug openings to prevent fluid from spilling.

#### REMOVAL

1. Remove engine under cover. Refer to [EXT-15, "Removal and Installation"](#).
2. Drain engine coolant from radiator. Refer to [CO-12, "Changing Engine Coolant"](#).

#### **CAUTION:**



# RADIATOR

[QR25DE]

## < REMOVAL AND INSTALLATION >

- Perform this step when engine is cold.
  - Do not spill engine coolant on drive belts.
3. Remove air duct and resonator assembly and air duct brackets. Refer to [EM-25. "Exploded View"](#).
  4. Remove reservoir tank hose.
  5. Removal (upper and lower) radiator hoses.  
**CAUTION:**  
**Be careful not to allow engine coolant to contact drive belts.**
  6. Disconnect A/T fluid cooler hoses. (A/T models)
  7. Remove lower shroud.
  8. Remove upper shroud.
  9. Remove front grille. Refer to [EXT-23. "Removal and Installation"](#).
  10. Remove the upper radiator mounting bracket bolts.

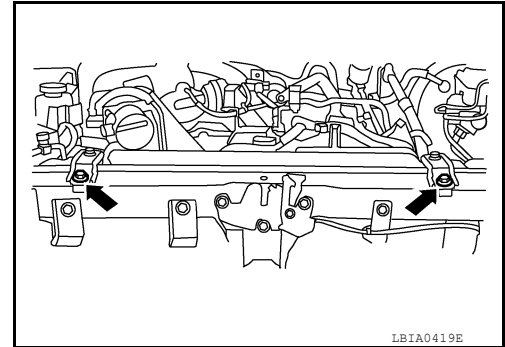

11. Remove the two A/C condenser bolts. (if equipped)

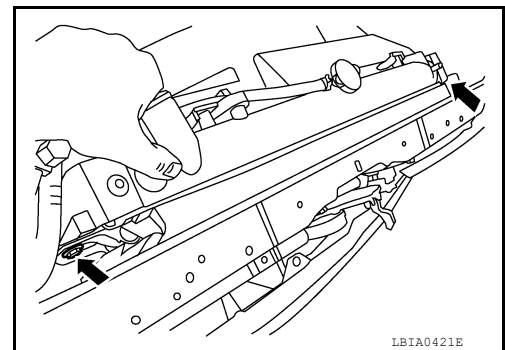

12. Remove radiator as follows:

**CAUTION:**

**Do not damage or scratch A/C condenser and radiator core when removing.**

- a. With lifting and pulling radiator in a rear direction, disassemble mounting rubber (lower) from radiator core support center.

**CAUTION:**

**Because A/C condenser is attached to the front-lower portion of radiator, moving it in the rear direction should be at a minimum.**

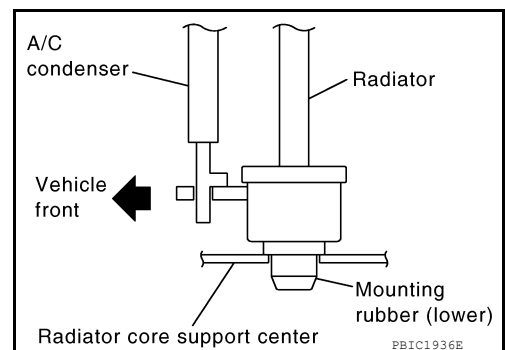

# RADIATOR

[QR25DE]

## < REMOVAL AND INSTALLATION >

- b. Lift A/C condenser up and remove radiator after disengaging the fitting at front-bottom surface.

**CAUTION:**

**Lifting A/C condenser should be minimum to prevent a load to A/C piping.**

- c. After removing radiator, put A/C condenser on radiator core support center to prevent a load to A/C piping, and temporarily secure it with rope or by similar means.

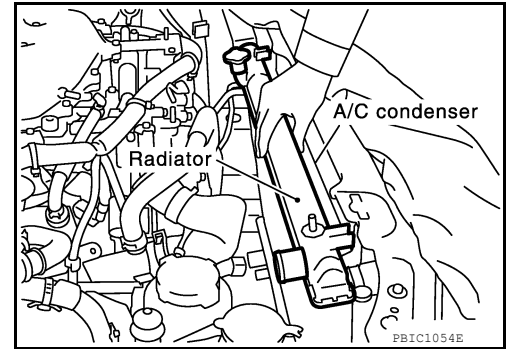

## INSTALLATION

Installation is in the reverse order of removal.

## INSPECTION AFTER INSTALLATION

- Check for engine coolant leaks. Refer to [CO-11. "System Inspection"](#).
- Start and warm up engine. Visually check for engine coolant and A/T fluid leaks. Repair as necessary.

# COOLING FAN

< REMOVAL AND INSTALLATION >

[QR25DE]

## COOLING FAN

### Exploded View

INFOID:000000007323364

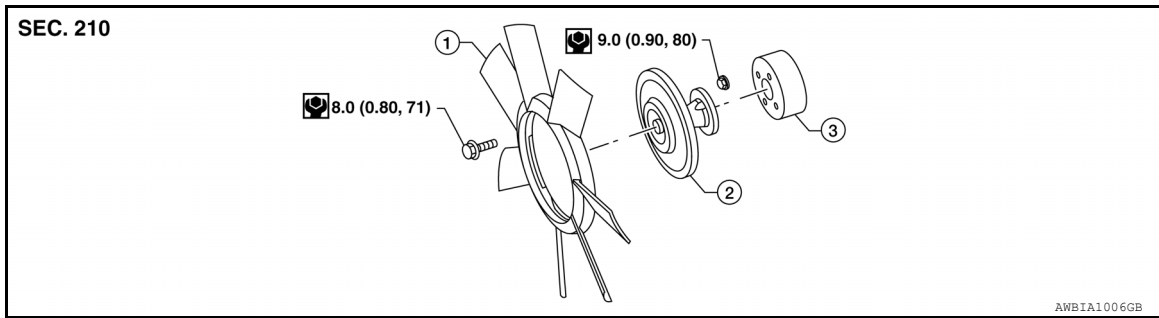

1. Cooling fan

2. Fan coupling

3. Water pump pulley

### Removal and Installation (Crankshaft driven type)

INFOID:000000007323365

#### WARNING:

Never remove the radiator cap when the engine is hot. Serious burns could occur from high pressure engine coolant escaping from the radiator. Wrap a thick cloth around the cap. Slowly turn it a quarter of a turn to release built-up pressure. Carefully remove radiator cap by turning it all the way.

#### NOTE:

When removing components such as hoses, tubes/lines, etc., cap or plug openings to prevent fluid from spilling.

#### REMOVAL

1. Remove the engine front under cover. Refer to [EXT-15. "Removal and Installation"](#).
2. Partially drain engine coolant. Refer to [CO-12. "Changing Engine Coolant"](#).
3. Remove air duct and resonator assembly and air duct mounting brackets. Refer to [EM-25. "Exploded View"](#).
4. Remove upper radiator hose.
5. Disconnect reservoir tank hose from upper shroud and radiator.
6. Remove the upper and lower shrouds. Refer to [CO-16. "Exploded View"](#).
7. Remove drive belt. Refer to [EM-14. "Removal and Installation"](#).
8. Remove cooling fan.
9. Remove fan coupling, if necessary.
10. Remove water pump pulley, if necessary.

#### INSPECTION AFTER REMOVAL

##### Fan Coupling

- Inspect fan coupling for oil leakage and bimetal conditions.
- If there are any concerns, replace the fan coupling.

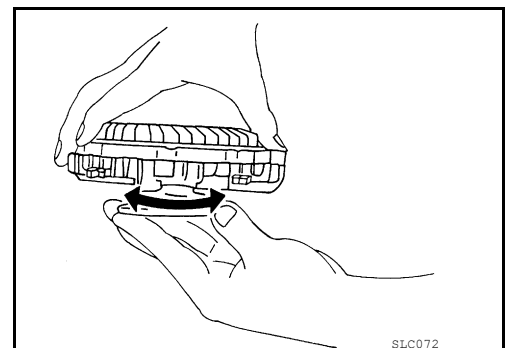

##### Cooling Fan

- Inspect cooling fan for cracks or warps.
- If there are any concerns, replace the cooling fan.

## COOLING FAN

< REMOVAL AND INSTALLATION >

[QR25DE]

---

### INSTALLATION

Installation is in the reverse order of removal.

- Install cooling fan with its front mark "F" facing front of engine.

### INSPECTION AFTER INSTALLATION

- Check for engine coolant leaks. Refer to [CO-11. "System Inspection"](#).
- Start and warm up the engine. Visually check for engine coolant leaks. Repair as necessary.

# WATER PUMP

< REMOVAL AND INSTALLATION >

[QR25DE]

## WATER PUMP

### Exploded View

INFOID:000000007323366

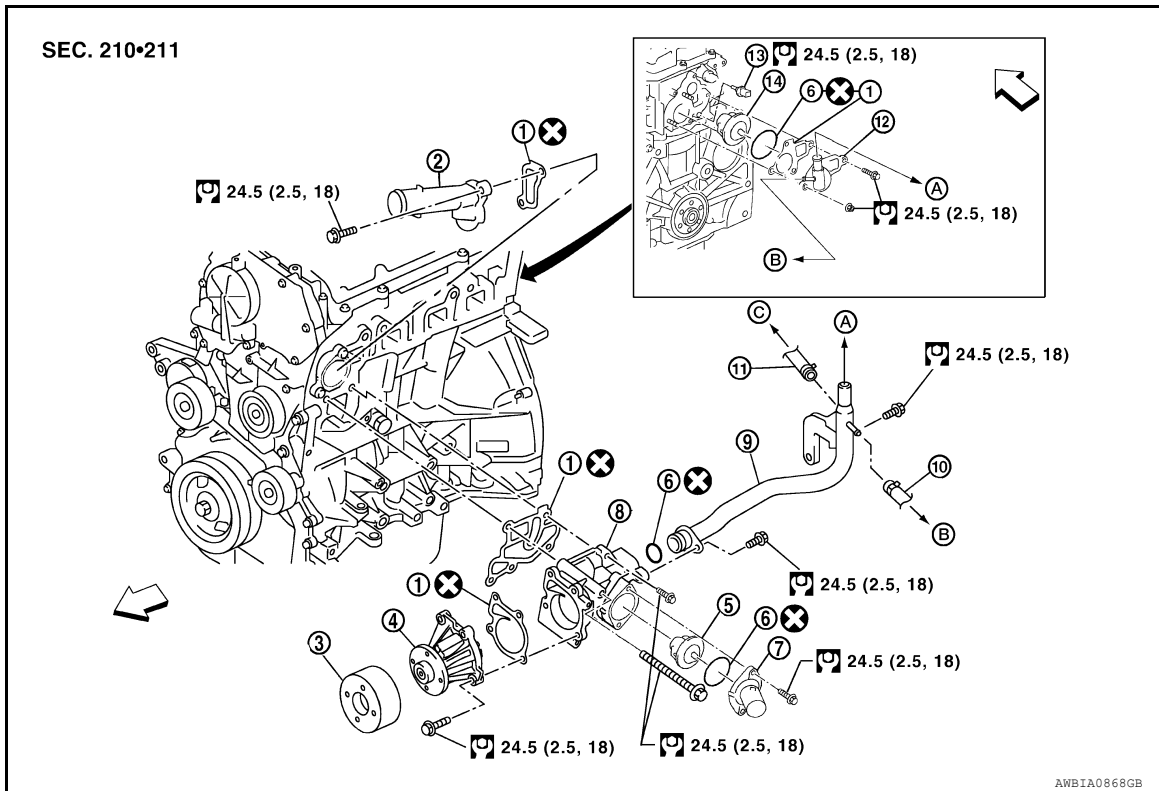

- |  |                                      |                      |
|--|--------------------------------------|----------------------|
| 1. Gasket                                | 2. Water outlet                      | 3. Water pump pulley |
| 4. Water pump                            | 5. Thermostat                        | 6. O-ring            |
| 7. Water inlet                           | 8. Water pump and thermostat housing | 9. Heater pipe       |
| 10. Water hose                           | 11. Water hose                       | 12. Heater outlet    |
| 13. Engine coolant temperature sensor    | 14. Water control valve              | A. To heater         |
| B. To electric throttle control actuator | C. To oil cooler                     | ⇐ Front              |

### Removal and Installation

INFOID:000000007323367

#### **WARNING:**

Never remove the radiator cap when the engine is hot. Serious burns could occur from high pressure engine coolant escaping from the radiator. Wrap a thick cloth around the cap. Slowly turn it a quarter of a turn to release built-up pressure. Carefully remove radiator cap by turning it all the way.

#### REMOVAL

1. Remove engine front under cover. Refer to [EXT-15, "Removal and Installation"](#).
2. Drain engine coolant from radiator. Refer to [CO-12, "Changing Engine Coolant"](#).  
**CAUTION:**
  - Perform this step when the engine is cold.
  - Do not spill engine coolant on drive belt.
3. Remove cooling fan and water pump pulley. Refer to [CO-19, "Removal and Installation \(Crankshaft driven type\)"](#).
4. Remove water pump with power tool.  
**CAUTION:**
  - Do not reuse gasket.
  - Handle water pump vane so that it does not contact any other parts.
  - Water pump cannot be disassembled and should be replaced as a unit.

# WATER PUMP

< REMOVAL AND INSTALLATION >

[QR25DE]

## NOTE:

- Engine coolant will leak from cylinder block, so have a receptacle ready below.

## INSPECTION AFTER REMOVAL

- Visually check for significant dirt or rust on the water pump body and vane.
- Check that the vane shaft turns smoothly by hand and is not excessively loose.
- Replace the water pump assembly if the water pump does not perform properly.

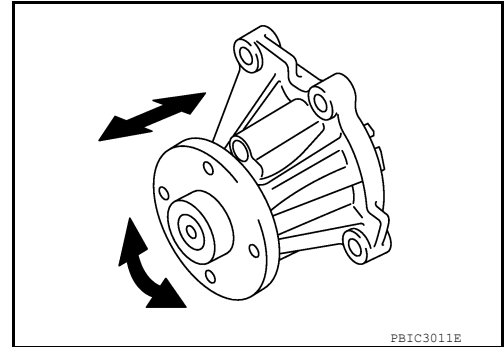

## INSTALLATION

Installation is in the reverse order of removal.

## INSPECTION AFTER INSTALLATION

- Check for engine coolant leaks. Refer to [CO-11. "System Inspection"](#).
- Start and warm up the engine. Visually check for engine coolant leaks. Repair as necessary.

# THERMOSTAT AND THERMOSTAT HOUSING

< REMOVAL AND INSTALLATION >

[QR25DE]

## THERMOSTAT AND THERMOSTAT HOUSING

Exploded View

INFOID:000000007323368

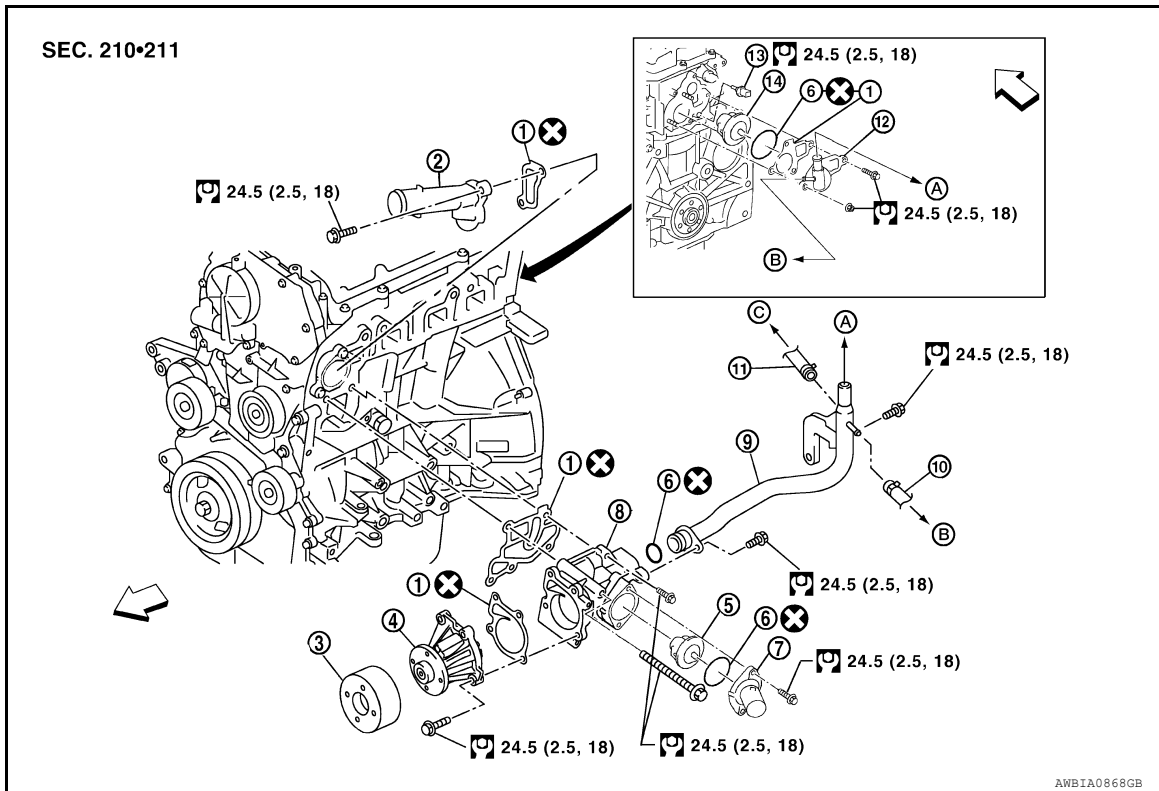

- |  |                                      |                      |
|--|--------------------------------------|----------------------|
| 1. Gasket                                | 2. Water outlet                      | 3. Water pump pulley |
| 4. Water pump                            | 5. Thermostat                        | 6. O-ring            |
| 7. Water inlet                           | 8. Water pump and thermostat housing | 9. Heater pipe       |
| 10. Water hose                           | 11. Water hose                       | 12. Heater outlet    |
| 13. Engine coolant temperature sensor    | 14. Water control valve              | A. To heater         |
| B. To electric throttle control actuator | C. To oil cooler                     | ⇐ Front              |

### Removal and Installation Thermostat

INFOID:000000007323369

#### **WARNING:**

Never remove the radiator cap when the engine is hot. Serious burns could occur from high pressure engine coolant escaping from the radiator. Wrap a thick cloth around the cap. Slowly turn it a quarter of a turn to release built-up pressure. Carefully remove radiator cap by turning it all the way.

#### REMOVAL

1. Drain engine coolant from the radiator. Refer to [CO-12. "Changing Engine Coolant"](#) and [EM-80. "Exploded View"](#).

#### **CAUTION:**

- Perform this step when the engine is cold.
- Do not spill engine coolant on drive belt.

2. Remove the air duct. Refer to [EM-25. "Exploded View"](#).
3. Disconnect radiator hose (lower) at water inlet side. Refer to [CO-16. "Exploded View"](#).
4. Remove water inlet, O-ring and thermostat.

#### **CAUTION:**

Do not reuse O-rings.

#### INSPECTION AFTER REMOVAL

# THERMOSTAT AND THERMOSTAT HOUSING

[QR25DE]

## < REMOVAL AND INSTALLATION >

- Place a thread so that it is caught in the valve of the thermostat. Immerse fully in a container filled with water. Heat while stirring.
- The valve opening temperature is the temperature at which the valve opens and falls from the thread.
- Continue heating. Check the full-open lift amount.

**NOTE:**

The full-open lift amount standard temperature is the reference value.

- After checking the full-open lift amount, lower the water temperature and check the valve closing temperature.

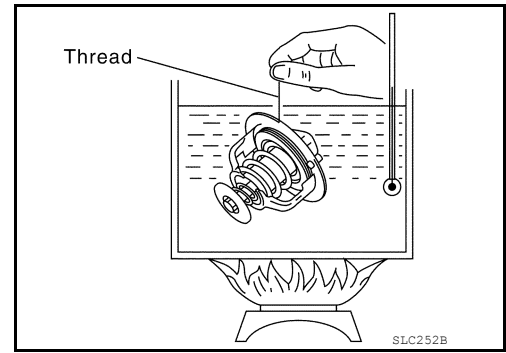

Thermostat	Standard
Valve opening temperature	Refer to <a href="#">CO-30, "Standard and Limit"</a>
Full-open lift amount	Refer to <a href="#">CO-30, "Standard and Limit"</a>
Valve closing temperature	Refer to <a href="#">CO-30, "Standard and Limit"</a>

If out of the specification range, replace the thermostat.

## INSTALLATION

Installation is in the reverse order of removal.

- Apply a mild soap to a new O-ring before inserting heater pipe end into water pump and thermostat housing. Then insert it immediately.

Thermostat

- Install thermostat by making O-ring (1) groove fit to thermostat flange (A) around the whole circumference.

**CAUTION:**

**Do not reuse O-ring.**

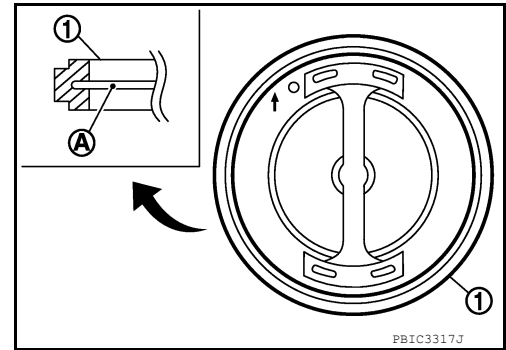

- Install thermostat with jiggle valve (A) facing upward. The position may deviate within the range of 20° (b).

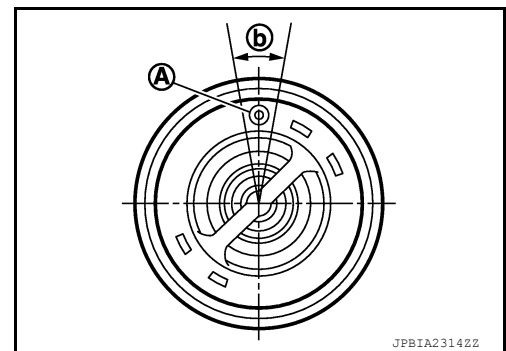

## INSPECTION AFTER INSTALLATION

- Check for engine coolant leaks. Refer to [CO-11, "System Inspection"](#).
- Start and warm up the engine. Visually check for engine coolant leaks. Repair as necessary.

## Removal and Installation Thermostat Housing

INFOID:000000007323370

**WARNING:**

Never remove the radiator cap when the engine is hot. Serious burns could occur from high pressure engine coolant escaping from the radiator. Wrap a thick cloth around the cap. Slowly turn it a quarter of a turn to release built-up pressure. Carefully remove radiator cap by turning it all the way.

**NOTE:**



# THERMOSTAT AND THERMOSTAT HOUSING

[QR25DE]

## < REMOVAL AND INSTALLATION >

When removing components such as hoses, tubes/lines, etc., cap or plug openings to prevent fluid from spilling.

### REMOVAL

1. Remove water pump. Refer to [CO-21](#).
2. Remove thermostat. Refer to [CO-23, "Removal and Installation Thermostat"](#).
3. Remove the radiator hose (upper) from the radiator.
4. Remove exhaust manifold cover. Refer to [EM-31, "Exploded View"](#).
5. Remove oil level gauge and oil level gauge guide. Refer to [EM-80, "Exploded View"](#).  
**CAUTION:**  
**Plug the oil level gauge guide opening to prevent foreign materials from entering oil pan.**
6. Remove A/C compressor (if equipped) without disconnecting the A/C hoses and position aside. Refer to [HA-28, "Removal and Installation for Compressor"](#).
7. Disconnect electric throttle control actuator, oil cooler and heater hose from heater pipe.
8. Remove bolt for heater pipe at water pump and thermostat housing.
9. Disconnect heater pipe from water pump and thermostat housing.
10. Remove water pump and thermostat housing.  
**CAUTION:**
  - Do not reuse O-ring.
  - Do not reuse gasket.

### INSTALLATION

Installation is in the reverse order of removal.

- Apply a mild soap to O-ring before inserting heater pipe end into water pump and thermostat housing. Then insert it immediately.

#### **CAUTION:**

**Do not reuse O-ring.**

### INSPECTION AFTER INSTALLATION

- Check for engine coolant leaks. Refer to [CO-11, "System Inspection"](#).
- Start and warm up the engine. Visually check for engine coolant leaks. Repair as necessary.

A  
CO  
C  
D  
E  
F  
G  
H  
I  
J  
K  
L  
M  
N  
O  
P

# WATER CONTROL VALVE

< REMOVAL AND INSTALLATION >

[QR25DE]

## WATER CONTROL VALVE

Exploded View

INFOID:000000007323371

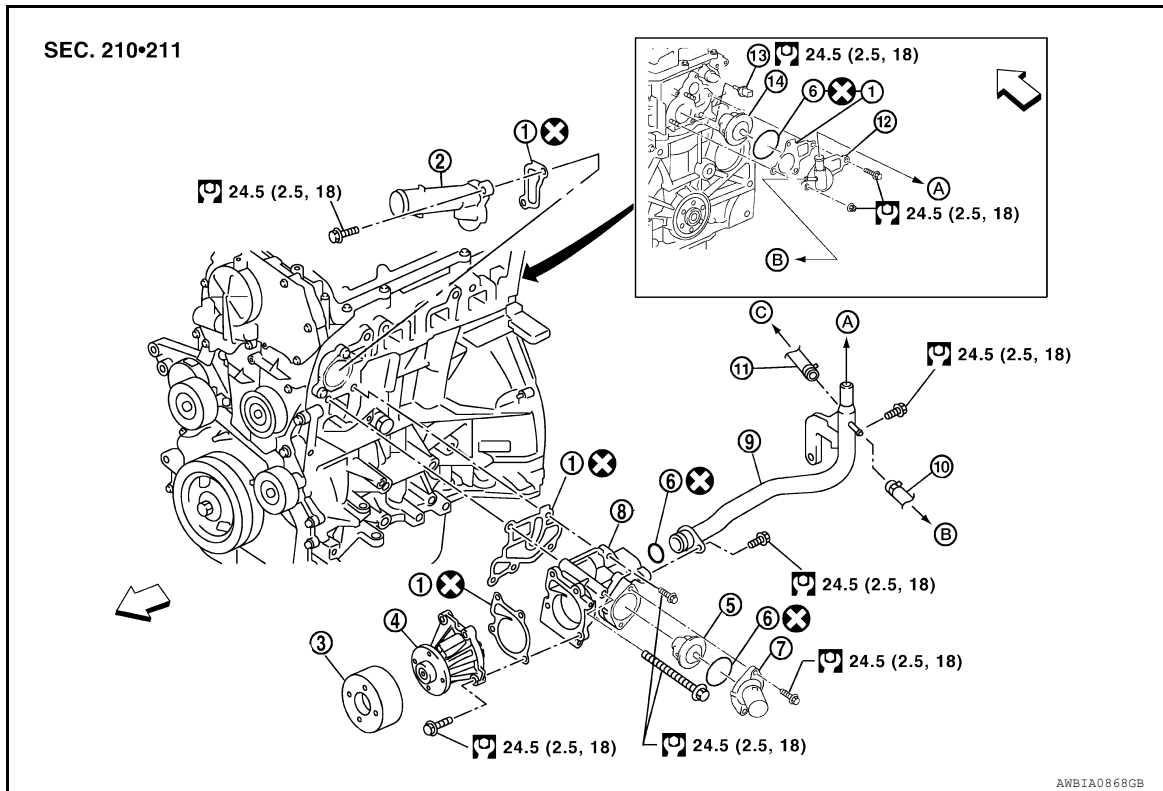

- |  |                                      |                      |
|--|--------------------------------------|----------------------|
| 1. Gasket                                | 2. Water outlet                      | 3. Water pump pulley |
| 4. Water pump                            | 5. Thermostat                        | 6. O-ring            |
| 7. Water inlet                           | 8. Water pump and thermostat housing | 9. Heater pipe       |
| 10. Water hose                           | 11. Water hose                       | 12. Heater outlet    |
| 13. Engine coolant temperature sensor    | 14. Water control valve              | A. To heater         |
| B. To electric throttle control actuator | C. To oil cooler                     | ⇐ Front              |

## Removal and Installation

INFOID:000000007323372

### **WARNING:**

Never remove the radiator cap when the engine is hot. Serious burns could occur from high pressure engine coolant escaping from the radiator. Wrap a thick cloth around the cap. Slowly turn it a quarter of a turn to release built-up pressure. Carefully remove radiator cap by turning it all the way.

### **NOTE:**

When removing components such as hoses, tubes/lines, etc., cap or plug openings to prevent fluid from spilling.

### REMOVAL

#### **CAUTION:**

Perform when the engine is cold.

1. Remove air ducts and resonator assembly.
2. Partially drain the engine coolant from the radiator. Refer to [CO-12, "Changing Engine Coolant"](#).
3. Remove radiator hose (upper) from the water outlet.
4. Remove the heater outlet.
5. Remove the water control valve.

### INSPECTION AFTER REMOVAL

# WATER CONTROL VALVE

[QR25DE]

## < REMOVAL AND INSTALLATION >

- Place a thread so that it is caught in the valve of the water control valve. Immerse fully in a container filled with water. Heat while stirring.
- The valve opening temperature is the temperature at which the valve opens and the falls from the thread.
- Continue heating. Check the full-open lift amount.

**NOTE:**

The full-open lift amount standard temperature is the reference value.

- After checking the full-open lift amount, lower the water temperature and check the valve closing temperature.

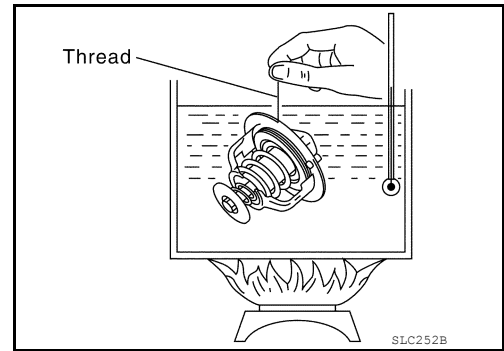

Water Control Valve	Standard Value
Valve opening temperature	Refer to <a href="#">CO-30, "Standard and Limit"</a>
Full-open lift amount	Refer to <a href="#">CO-30, "Standard and Limit"</a>
Valve closing temperature	Refer to <a href="#">CO-30, "Standard and Limit"</a>

If out of the specification range, replace the water control valve.

## INSTALLATION

Installation is in the reverse order of removal.

### Water Control Valve

- Install water control valve by making O-ring (1) groove fit to water control valve flange (A) around the whole circumference.

**CAUTION:**

**Do not reuse O-ring.**

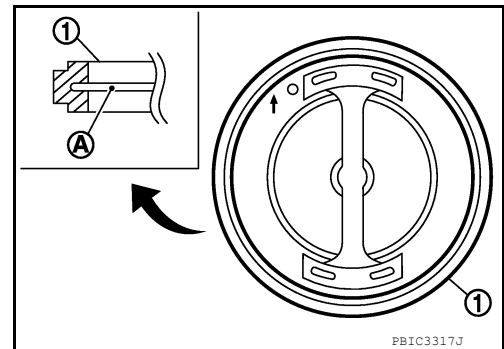

- Install water control valve with jiggle valve (A) facing upward. The position may deviate within the range of 20° (b).
- Install the engine coolant temperature sensor if removed.

**Use Genuine RTV Silicone Sealant or equivalent. Refer to [GL-22, "Recommended Chemical Products and Sealants"](#).**

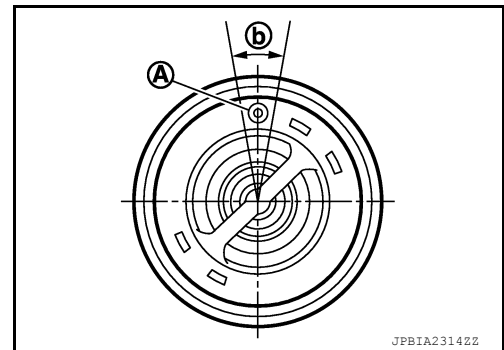

A  
CO  
C  
D  
E  
F  
G  
H  
I  
J  
K  
L  
M  
N  
O  
P

# WATER OUTLET AND WATER PIPING

< REMOVAL AND INSTALLATION >

[QR25DE]

## WATER OUTLET AND WATER PIPING

### Exploded View

INFOID:000000007323373

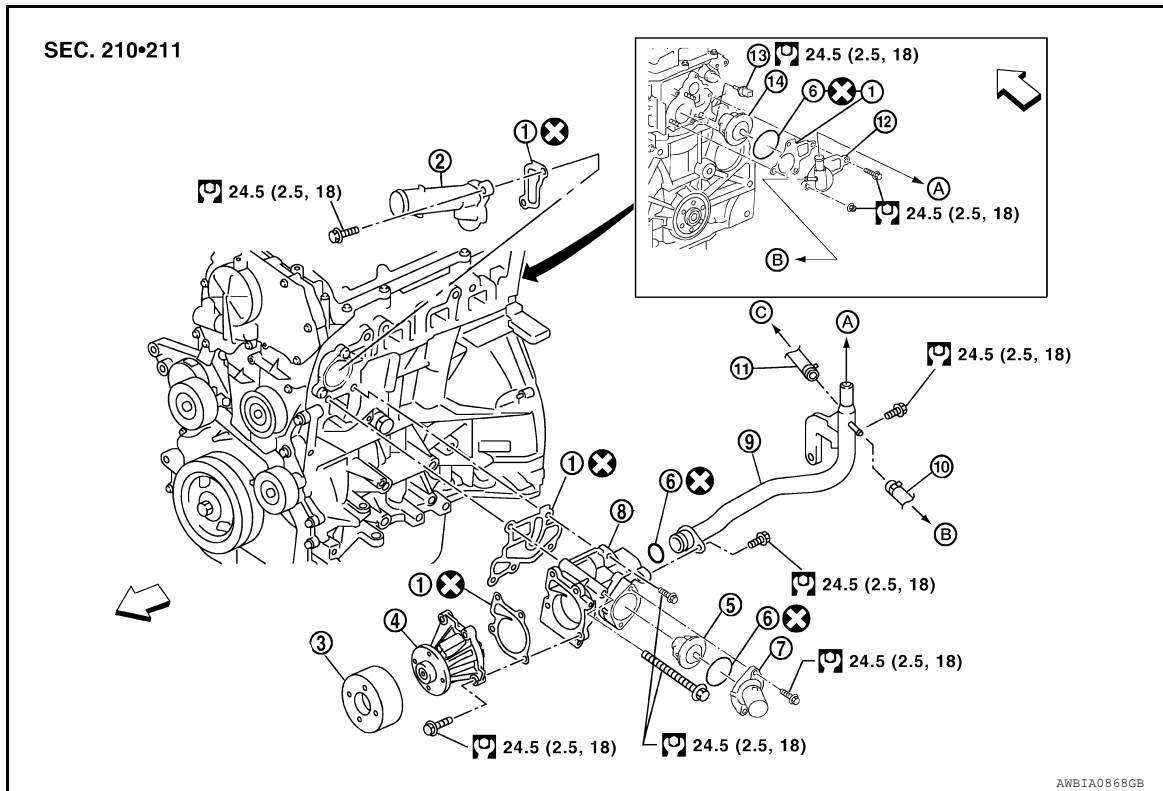

- |  |                                      |                      |
|--|--------------------------------------|----------------------|
| 1. Gasket                                | 2. Water outlet                      | 3. Water pump pulley |
| 4. Water pump                            | 5. Thermostat                        | 6. O-ring            |
| 7. Water inlet                           | 8. Water pump and thermostat housing | 9. Heater pipe       |
| 10. Water hose                           | 11. Water hose                       | 12. Heater outlet    |
| 13. Engine coolant temperature sensor    | 14. Water control valve              | A. To heater         |
| B. To electric throttle control actuator | C. To oil cooler                     | ⇐ Front              |

### Removal and Installation

INFOID:000000007323374

#### **WARNING:**

Never remove the radiator cap when the engine is hot. Serious burns could occur from high pressure engine coolant escaping from the radiator. Wrap a thick cloth around the cap. Slowly turn it a quarter of a turn to release built-up pressure. Carefully remove radiator cap by turning it all the way.

#### **NOTE:**

When removing components such as hoses, tubes/lines, etc., cap or plug openings to prevent fluid from spilling.

#### REMOVAL

1. Drain engine coolant from the radiator. Refer to [CO-12, "Changing Engine Coolant"](#).  
**CAUTION:**
  - Perform this step when engine is cold.
  - Do not spill engine coolant on drive belts.
2. Remove the air duct. Refer to [EM-25, "Exploded View"](#).
3. Disconnect radiator hose (upper) at water outlet side. Refer to [CO-16, "Exploded View"](#).
4. Remove water outlet.
5. Remove throttle body coolant hose at heater pipe.
6. Remove heater core coolant hose at heater pipe.

# WATER OUTLET AND WATER PIPING

[QR25DE]

## < REMOVAL AND INSTALLATION >

7. Remove oil cooler coolant hose at heater pipe.
8. Remove oil level gauge and oil level gauge guide.
9. Remove exhaust manifold heat shield.
10. Remove heater pipe and O-ring.

**CAUTION:**

**Do not reuse O-ring.**

## INSTALLATION

Installation is in the reverse order of removal.

- Securely insert each hose, and install clamp at a position where it does not interfere with the pipe bulge.

## INSPECTION AFTER INSTALLATION

- Check for engine coolant leaks. Refer to [CO-11. "System Inspection"](#).
- Start and warm up engine. Visually check for engine coolant leaks. Repair as necessary.

A

CO

C

D

E

F

G

H

I

J

K

L

M

N

O

P

# SERVICE DATA AND SPECIFICATIONS (SDS)

< SERVICE DATA AND SPECIFICATIONS (SDS)

[QR25DE]

## SERVICE DATA AND SPECIFICATIONS (SDS)

### SERVICE DATA AND SPECIFICATIONS (SDS)

#### Standard and Limit

INFOID:000000007323375

#### ENGINE COOLANT CAPACITY (APPROXIMATE)

Unit: ℓ (US qt, Imp qt)

Engine coolant capacity (With reservoir tank at "MAX" level)	9.4 (10, 8-1/4)
--	-----------------

#### RADIATOR

Unit: kPa (kg/cm<sup>2</sup>, psi)

Reservoir cap relief pressure	Standard	98 - 118 (1.0 - 1.2, 14- 17)
Leak test pressure		156 (1.6, 23)

#### THERMOSTAT

Valve opening temperature	80.5 - 83.5°C (177 - 182°F)
Full-open lift amount	8 mm/ 95°C (0.315 in/ 203°F)
Valve closing temperature	77°C (171°F)

#### WATER CONTROL VALVE

Valve opening temperature	93.5 - 96.5°C (200 - 206°F)
Full-open lift amount	More than 8 mm/ 108°C (0.315 in/ 226°F)
Valve closing temperature	90°C (194°F) or higher

PRECAUTION

PRECAUTIONS

Precaution for Supplemental Restraint System (SRS) "AIR BAG" and "SEAT BELT PRE-TENSIONER"

INFOID:000000007323376

The Supplemental Restraint System such as "AIR BAG" and "SEAT BELT PRE-TENSIONER", used along with a front seat belt, helps to reduce the risk or severity of injury to the driver and front passenger for certain types of collision. This system includes seat belt switch inputs and dual stage front air bag modules. The SRS system uses the seat belt switches to determine the front air bag deployment, and may only deploy one front air bag, depending on the severity of a collision and whether the front occupants are belted or unbelted. Information necessary to service the system safely is included in the SR and SB section of this Service Manual.

**WARNING:**

- To avoid rendering the SRS inoperative, which could increase the risk of personal injury or death in the event of a collision which would result in air bag inflation, all maintenance must be performed by an authorized NISSAN/INFINITI dealer.
- Improper maintenance, including incorrect removal and installation of the SRS, can lead to personal injury caused by unintentional activation of the system. For removal of Spiral Cable and Air Bag Module, see the SR section.
- Do not use electrical test equipment on any circuit related to the SRS unless instructed to in this Service Manual. SRS wiring harnesses can be identified by yellow and/or orange harnesses or harness connectors.

PRECAUTIONS WHEN USING POWER TOOLS (AIR OR ELECTRIC) AND HAMMERS

**WARNING:**

- When working near the Airbag Diagnosis Sensor Unit or other Airbag System sensors with the Ignition ON or engine running, DO NOT use air or electric power tools or strike near the sensor(s) with a hammer. Heavy vibration could activate the sensor(s) and deploy the air bag(s), possibly causing serious injury.
- When using air or electric power tools or hammers, always switch the Ignition OFF, disconnect the battery, and wait at least 3 minutes before performing any service.

Precaution for Liquid Gasket

INFOID:000000007323377

REMOVAL OF LIQUID GASKET

- After removing the bolts and nuts, separate the mating surface and remove the old liquid gasket using Tool.

Tool number : KV10111100 (J-37228)

**CAUTION:**

Do not damage the mating surfaces.

- Tap the seal cutter to insert it (1).
- In areas where the Tool is difficult to use, lightly tap to slide it (2).

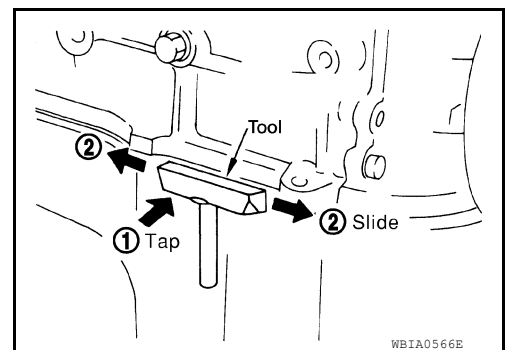

LIQUID GASKET APPLICATION PROCEDURE

A  
CO  
C  
D  
E  
F  
G  
H  
I  
J  
K  
L  
M  
N  
O  
P

# PRECAUTIONS

[VQ40DE]

## < PRECAUTION >

1. Remove the old liquid gasket adhering to the gasket application surface and the mating surface using suitable tool.
  - Remove the liquid gasket completely from the groove of the liquid gasket application surface, bolts, and bolt holes.
2. Thoroughly clean the mating surfaces and remove adhering moisture, grease and foreign material.

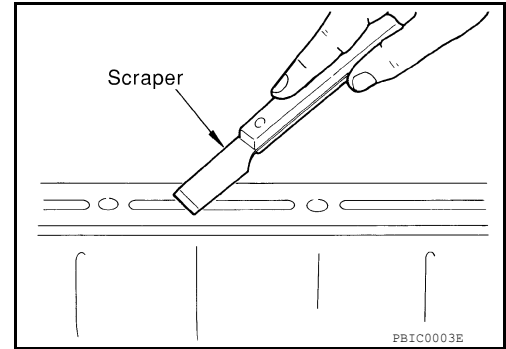

3. Attach the liquid gasket tube to the Tool.

**Tool number** : WS39930000 ( — )

**Use Genuine RTV Silicone Sealant or equivalent. Refer to [GI-22, "Recommended Chemical Products and Sealants"](#).**

4. Apply the liquid gasket without breaks to the specified location with the specified dimensions.

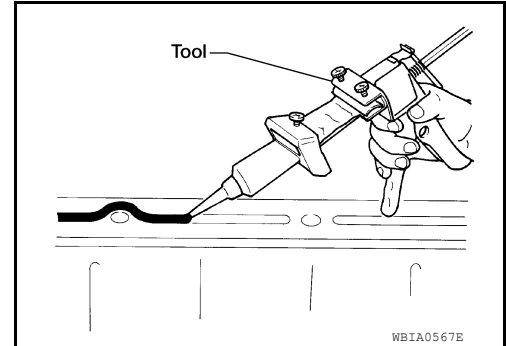

- If there is a groove for the liquid gasket application, apply the liquid gasket to the groove.
- Normally apply the liquid gasket on the inside edge of the bolt holes. Also apply to the outside edge of the bolt holes when specified in the procedure.
- Within five minutes of liquid gasket application, install the mating component.
- If the liquid gasket protrudes, wipe it off immediately.
- Do not retighten after the installation.
- Wait 30 minutes or more after installation before refilling the engine with oil or coolant.

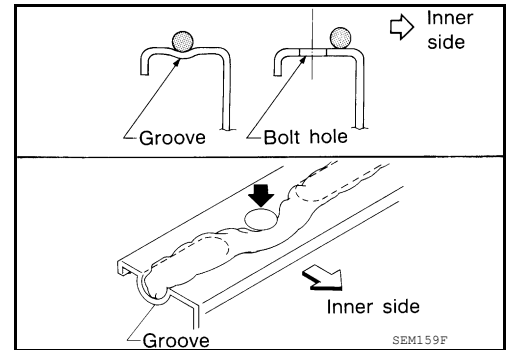

### **CAUTION:**

**Carefully follow all of the warnings, cautions, notes, and procedures contained in this manual.**



# PREPARATION

< PREPARATION >

[VQ40DE]

## PREPARATION

### PREPARATION

#### Special Service Tool

INFOID:000000007323378

A

CO

The actual shapes of Kent-Moore tools may differ from those of special service tools illustrated here.

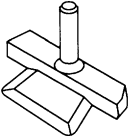
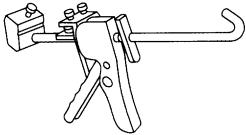
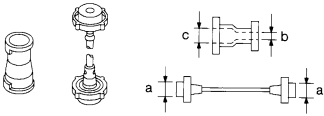
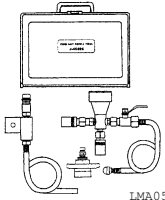
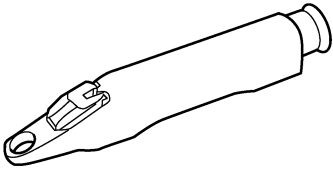
Tool number (Kent-Moore No.) Tool name	Description
KV10111100 (J-37228) Seal cutter   NT046	Removing chain tensioner cover and water pump cover  D  E
WS39930000 ( — ) Tube presser   S-NT052	Pressing the tube of liquid gasket  F  G  H
EG17650301 (J-33984-A) Radiator cap tester adapter   S-NT564	Adapting radiator cap tester to radiator cap and radiator filler neck <b>a: 28 (1.10) dia.</b> <b>b: 31.4 (1.236) dia.</b> <b>c: 41.3 (1.626) dia.</b> Unit: mm (in)  I  J
KV991J0070 (J-45695) Coolant refill tool   LMA053	Filling cooling system  K  L  M
KV991J0010 (J-23688) Engine coolant refractometer   WBIA0539E	Checking concentration of ethylene glycol in engine coolant  N  O

#### Commercial Service Tool

INFOID:000000007323379

P

# PREPARATION

< PREPARATION >

[VQ40DE]

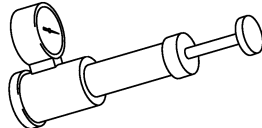
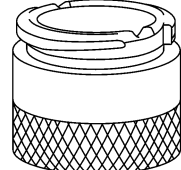
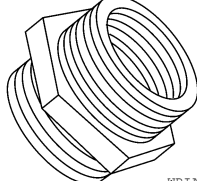
Tool name	Description
<p data-bbox="162 199 267 220">Power tool</p>  <p data-bbox="828 409 901 430">PIIB1407E</p>	<p data-bbox="1015 199 1347 220">Loosening nuts, screws and bolts</p>
<p data-bbox="162 451 349 472">Radiator cap tester</p>  <p data-bbox="828 661 901 682">PBIC1982E</p>	<p data-bbox="1015 451 1356 472">Checking radiator and radiator cap</p>
<p data-bbox="162 703 462 724">Coolant system tester adapter</p>  <p data-bbox="828 913 901 934">WBIA0408E</p>	<p data-bbox="1015 703 1453 745">Adapting radiator cap tester to reservoir filler neck</p>
<p data-bbox="162 955 462 976">Coolant system tester adapter</p>  <p data-bbox="828 1165 901 1186">WBIA0409E</p>	<p data-bbox="1015 955 1453 976">Adapting radiator cap tester to reservoir cap</p>

# COOLING SYSTEM

< SYSTEM DESCRIPTION >

[VQ40DE]

## SYSTEM DESCRIPTION

### COOLING SYSTEM

#### Cooling Circuit

INFOID:000000007323380

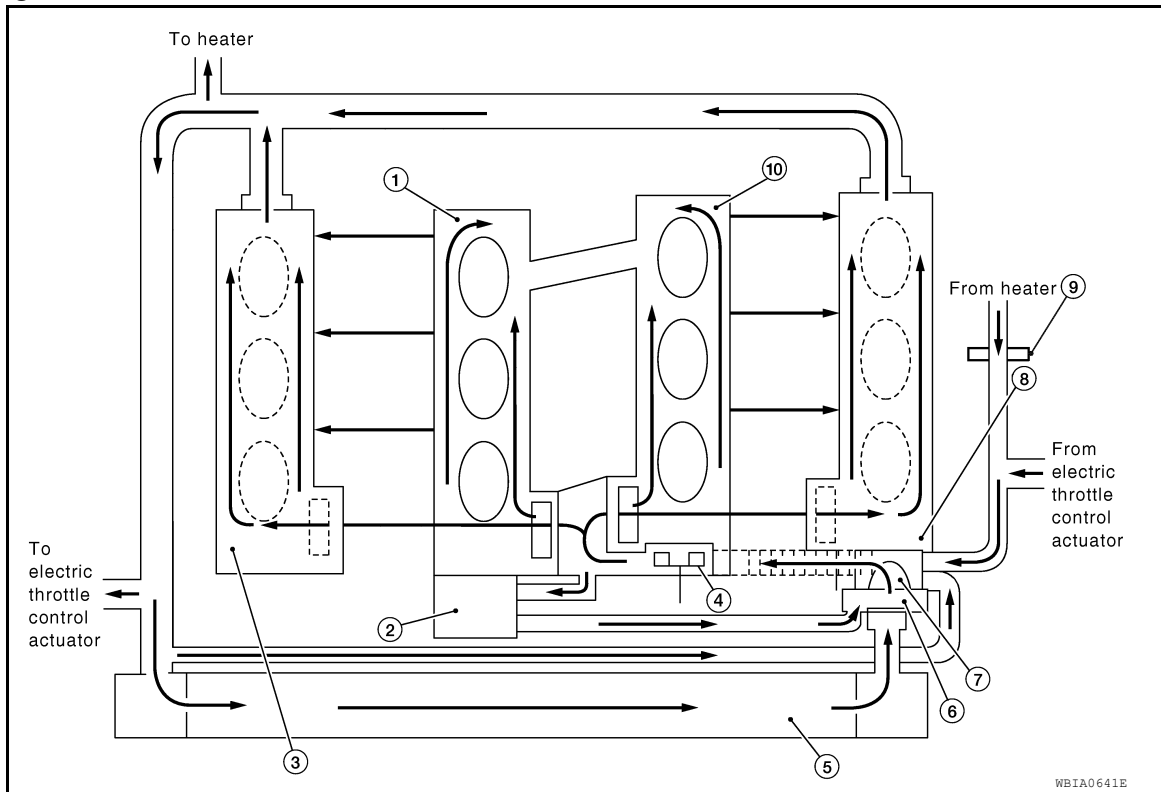

- |                         |                       |                       |
|-------------------------|-----------------------|-----------------------|
| 1. Cylinder block (RH)  | 2. Oil cooler         | 3. Cylinder head (RH) |
| 4. Water pump           | 5. Radiator           | 6. Water inlet        |
| 7. Thermostat           | 8. Cylinder head (LH) | 9. Heater pump        |
| 10. Cylinder block (LH) |                       |                       |

# COOLING SYSTEM

< SYSTEM DESCRIPTION >

[VQ40DE]

## Schematic

INFOID:000000007323381

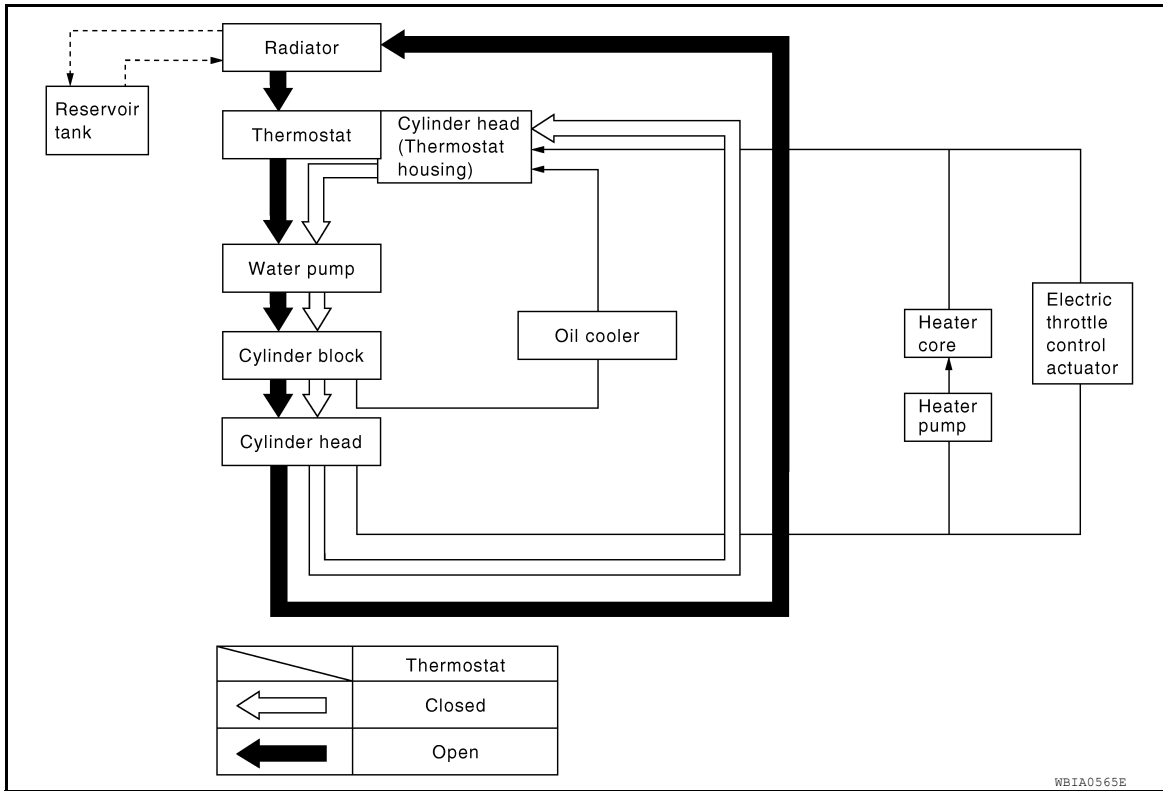

WBIA0565E

# OVERHEATING CAUSE ANALYSIS

< SYSTEM DESCRIPTION >

[VQ40DE]

## OVERHEATING CAUSE ANALYSIS

### Troubleshooting Chart

INFOID:000000007323382

		Symptom	Check items	
Cooling system parts malfunction	Poor heat transfer	Water pump malfunction	Worn or loose drive belt	—
		Thermostat stuck closed	Thermostat	
		Damaged fins	Dust contamination or paper clogging	
			Physical damage	
		Clogged radiator cooling tube	Excess foreign material (rust, dirt, sand, etc.)	
	Reduced air flow	Cooling fan does not operate	Fan assembly	—
		High resistance to fan rotation		
		Damaged fan blades		
	Damaged radiator shroud	—	Radiator shroud	—
	Improper engine coolant mixture ratio	—	Engine coolant viscosity	—
	Poor engine coolant quality	—		—
	Insufficient engine coolant	Engine coolant leaks	Cooling hose	Loose clamp
				Cracked hose
			Heater pump	Physical damage
			Water pump	Poor sealing
			Radiator or reservoir cap	Loose
				Poor sealing
		Radiator	Cracked radiator tank	
Cracked radiator core				
Reservoir tank	Cracked reservoir tank			
Overflowing reservoir tank	Exhaust gas leaks into cooling system	Cylinder head deterioration		
		Cylinder head gasket deterioration		

A  
CO  
C  
D  
E  
F  
G  
H  
I  
J  
K  
L  
M  
N  
O  
P

# OVERHEATING CAUSE ANALYSIS

< SYSTEM DESCRIPTION >

[VQ40DE]

	Symptom		Check items		
Except cooling system parts malfunction	—	Overload on engine	Abusive driving	High engine rpm under no load	
				Driving in low gear for extended time	
				Driving at extremely high speed	
			Powertrain system malfunction	—	
			Installed improper size wheels and tires		
			Dragging brakes		
	Improper ignition timing				
	Blocked or restricted air flow	Blocked bumper	Mud contamination or paper clogging	—	
			Blocked radiator grille		Installed car brassiere
			Mud contamination or paper clogging		
			Blocked radiator		Blocked air flow
			Blocked condenser		
Installed large fog lamp					

# PERIODIC MAINTENANCE

## ENGINE COOLANT

### System Inspection

INFOID:000000007323383

#### WARNING:

- Never remove the radiator/reservoir cap when the engine is hot. Serious burns could occur from high pressure fluid escaping from the radiator or reservoir.
- Wrap a thick cloth around the cap. Slowly push down and turn it a quarter turn to allow built-up pressure to escape. Carefully remove the cap by pushing down and turning it all the way.

#### CHECKING COOLING SYSTEM HOSES

Check hoses for the following:

- Improper attachment
- Leaks
- Cracks
- Damage
- Loose connections
- Chafing
- Deterioration

#### CHECKING RESERVOIR LEVEL

- Check if the engine coolant reservoir tank level is within MIN to MAX when the engine is cool.
- Adjust engine coolant level as necessary.

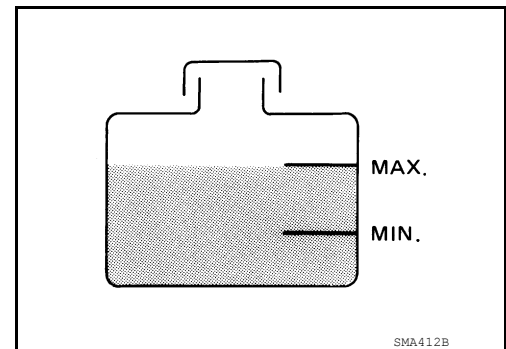

#### CHECKING COOLING SYSTEM FOR LEAKS

#### WARNING:

Never remove the radiator/reservoir cap when the engine is hot. Serious burns could occur from high pressure coolant escaping from the radiator or reservoir.

- To check for leakage, apply pressure to the cooling system at the reservoir filler neck using suitable tool and Tool.

**Tool number** : EG17650301 (J-33984-A)

**Testing pressure** : 156 kPa (1.6 kg/cm<sup>2</sup>, 23 psi)

#### CAUTION:

Higher pressure than specified may cause radiator damage.

#### NOTE:

In case that engine coolant decreases, replenish cooling system with engine coolant.

- If any concerns are found, repair or replace damaged parts.

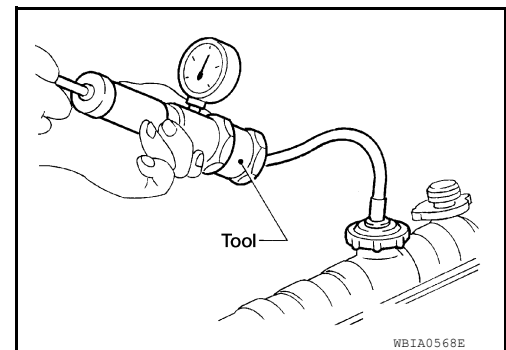

#### CHECKING RESERVOIR CAP

1. Inspect the reservoir cap.
  - Replace the cap if the metal plunger cannot be seen around the edge of the black rubber gasket.
  - Replace the cap if deposits of waxy residue or other foreign material are on the black rubber gasket or the metal retainer.

#### NOTE:

Thoroughly wipe out the reservoir filler neck to remove any waxy residue or foreign material.

# ENGINE COOLANT

[VQ40DE]

## < PERIODIC MAINTENANCE >

2. Pull the negative-pressure valve to open it and check that it closes completely when released.
  - Check that there is no dirt or damage on the valve seat of the reservoir cap negative-pressure valve.
  - Check that there are no abnormalities in the opening and closing conditions of the negative-pressure valve.

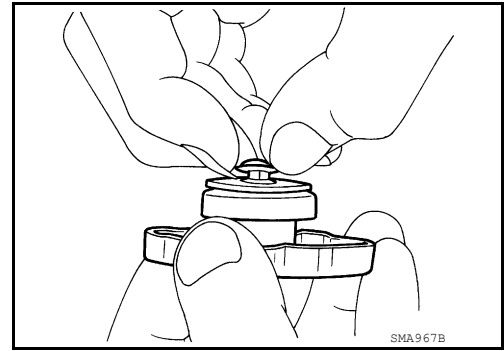

3. Check reservoir cap relief pressure using suitable tool and Tool.

**Tool number** : EG17650301 (J-33984-A)

**Standard** : 98 – 118 kPa (1.0 – 1.2 kg/cm<sup>2</sup>, 14 – 17 psi)

### NOTE:

- Apply engine coolant to the cap seal surface.
- Replace the reservoir cap if there is any damage in the negative-pressure valve, or if the open-valve pressure is outside of the limit.

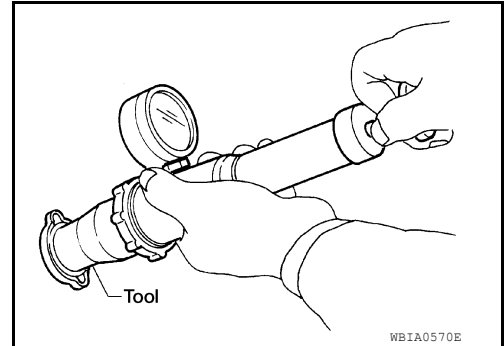

## CHECKING RADIATOR CAP

Inspect the radiator cap.

### NOTE:

Thoroughly wipe out the radiator filler neck to remove any waxy residue or foreign material.

- Replace the cap if deposits of waxy residue or other foreign material are on the black rubber gasket or the metal retainer.

## CHECKING RADIATOR

Check radiator for mud or clogging. If necessary, clean radiator as follows.

### CAUTION:

- **Be careful not to bend or damage the radiator fins.**
  - **When radiator is cleaned without removal, remove all surrounding parts such as cooling fan shroud and horns. Then tape the harness and electrical connectors to prevent water from entering.**
1. Spray water to the back side of the radiator core using a side to side motion from the top down.
  2. Stop spraying when debris no longer flows from radiator core.
  3. Blow air into the back side of radiator core using a side to side motion from the top down.
    - Use compressed air lower than 490 kPa (5 kg/cm<sup>2</sup>, 71 psi) and keep distance more than 30 cm (11.8 in).
  4. Continue to blow air until no water sprays out.
  5. Check for coolant leaks. Repair as necessary.

## Changing Engine Coolant

INFOID:000000007323384

### WARNING:

- **To avoid being scalded, never change the coolant when the engine is hot.**
- **Wrap a thick cloth around the cap to carefully remove the cap. First, turn the cap a quarter of a turn to release any built-up pressure, then push down and turn the cap all the way to remove it.**
- **Avoid direct skin contact with used coolant. If skin contact is made, wash thoroughly with soap or hand cleaner as soon as possible.**
- **Keep coolant out of the reach of children and pets.**

## DRAINING ENGINE COOLANT

1. Turn ignition switch ON and set temperature control lever all the way to HOT position or the highest temperature position. Wait 10 seconds and turn ignition switch OFF.
2. Remove the engine under cover. Refer to [EXT-15, "Removal and Installation"](#).



# ENGINE COOLANT

[VQ40DE]

## < PERIODIC MAINTENANCE >

3. Open the radiator drain plug at the bottom of the radiator, and remove the reservoir cap. This is the only step required when partially draining the cooling system (radiator only).

**CAUTION:**

- Do not allow the coolant to contact the drive belts.
- Perform this step when engine is cold.

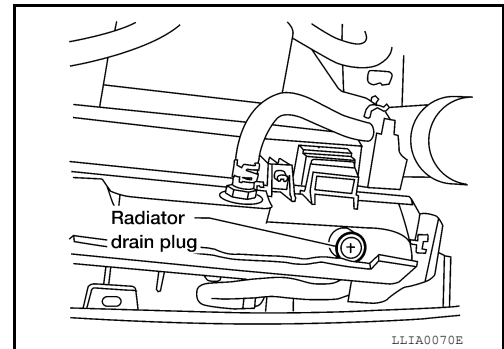

4. When draining all of the coolant in the system for engine removal or repair, it is necessary to drain the cylinder block. Remove the cylinder block drain plugs (A), (B), (C), (D) and block heater (if equipped), to drain the cylinder block as shown.

**CAUTION:**

**Do not reuse copper sealing washers.**

**NOTE:**

For Canada, the (D) cylinder block drain plug as shown, is not a cylinder block drain plug but a block heater.

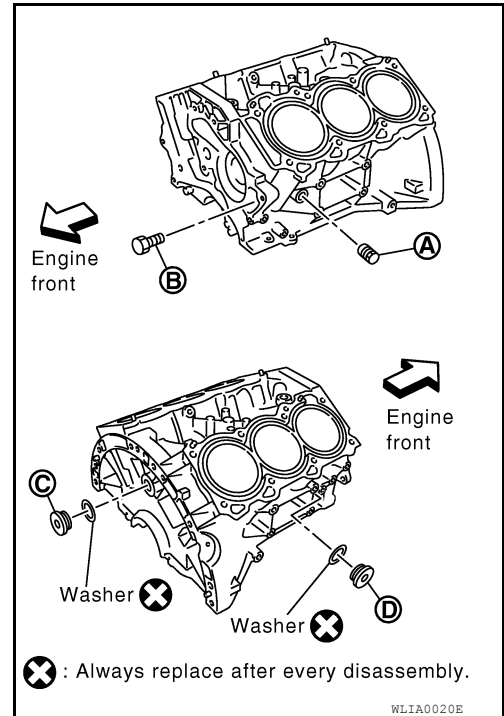

5. Remove the reservoir tank to drain the engine coolant, then clean the reservoir tank before installing it.
6. Check the drained coolant for contaminants such as rust, corrosion or discoloration. If the coolant is contaminated, flush the engine cooling system. Follow the "Flushing Cooling System" procedure.

## REFILLING ENGINE COOLANT

# ENGINE COOLANT

[VQ40DE]

## < PERIODIC MAINTENANCE >

1. Close the radiator drain plug. Install the reservoir tank, cylinder block drain plugs (A), (B), (C), (D) and block heater (if equipped).

**CAUTION:**

**Do not reuse copper sealing washers.**

- The radiator must be completely empty of coolant and water.
- Apply sealant to the threads of the cylinder block drain plugs (A), (B), (C), (D).
- **Use Genuine High Performance Thread Sealant or equivalent. Refer to [GI-22, "Recommended Chemical Products and Sealants"](#).**
- Tighten each plug to the specified torque. Refer to [EM-219, "Disassembly and Assembly"](#).

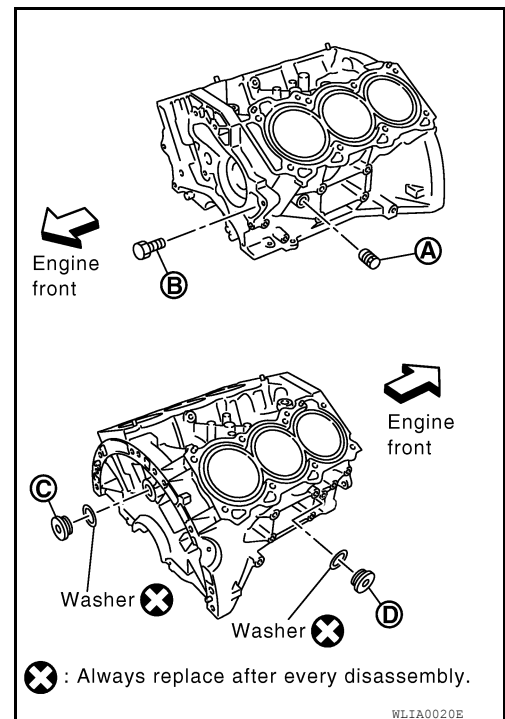

2. Set the vehicle heater controls to the full HOT and heater ON position. Turn the vehicle ignition ON with the engine OFF as necessary to activate the heater mode.
3. Remove the vented reservoir cap and replace it with a non-vented reservoir cap before filling the cooling system.
4. Install the Tool by installing the radiator cap adapter onto the radiator neck opening. Then attach the gauge body assembly with the refill tube and the venturi assembly to the radiator cap adapter.

**Tool number : KV991J0070 (J-45695)**

5. Insert the refill hose into the coolant mixture container that is placed at floor level. Make sure the ball valve is in the closed position.

**CAUTION:**

**Do not use any cooling system additives such as radiator sealer. Additives may clog the cooling system and cause damage to the engine, transmission and/or cooling system.**

**NOTE:**

Use recommended coolant or equivalent. Refer to [MA-18, "FOR USA AND CANADA : Fluids and Lubricants"](#) (United States and Canada) or [MA-20, "FOR MEXICO : Fluids and Lubricants"](#) (Mexico).

**Cooling system capacity (with reservoir) : [CO-59, "Standard and Limit"](#)**

6. Install an air hose to the venturi assembly, the air pressure must be within specification.

**Compressed air supply pressure : 549 - 824 kPa (5.6 - 8.4 kg/cm<sup>2</sup>, 80 - 119 psi)**

**CAUTION:**

**The compressed air supply must be equipped with an air dryer.**

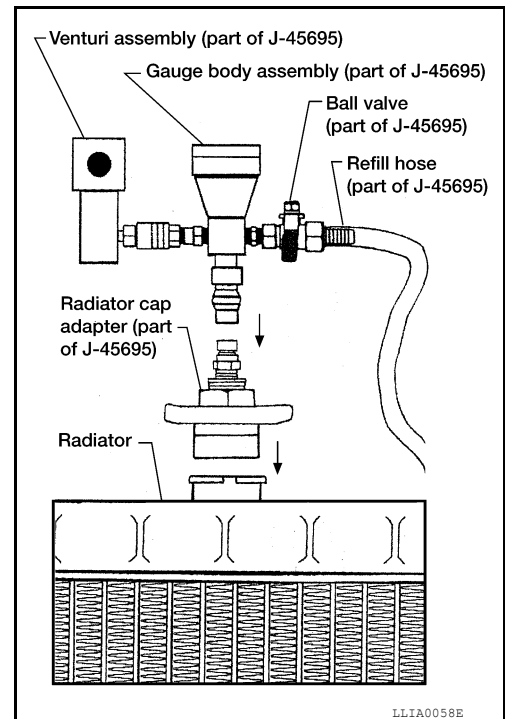

# ENGINE COOLANT

[VQ40DE]

## < PERIODIC MAINTENANCE >

7. The vacuum gauge will begin to rise and there will be an audible hissing noise. During this process open the ball valve on the refill hose slightly. Rising coolant will be visible in the refill hose. After the refill hose is full of coolant, close the ball valve. This will purge air trapped in the refill hose.

8. Continue to draw the vacuum until the gauge reaches 28 inches of vacuum. The gauge may not reach 28 inches in high altitude locations. Refer to the following table for expected vacuum readings.

Altitude above sea level	Vacuum gauge reading
0 - 100 m (328 ft)	: 28 inches of vacuum
300 m (984 ft)	: 27 inches of vacuum
500 m (1,641 ft)	: 26 inches of vacuum
1,000 m (3,281 ft)	: 24 - 25 inches of vacuum

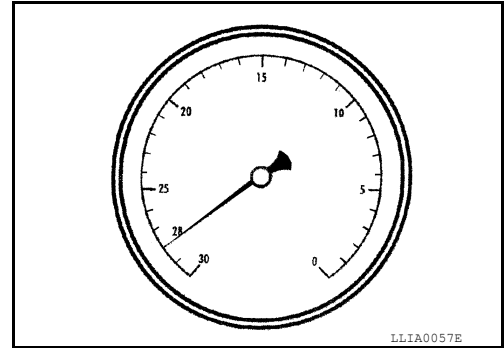

9. When the vacuum gauge has reached the specified amount, disconnect the air hose and wait 20 seconds to see if the system loses vacuum. If the vacuum level drops, perform necessary repairs to the system and repeat steps 6 - 8 to bring the vacuum to the specified amount. Recheck for leaks.

10. Place the coolant container (with the refill hose inserted) at the same level as the top of the radiator. Then open the ball valve on the refill hose so the coolant will be drawn up to fill the cooling system. The cooling system is full when the vacuum gauge reads zero.

### **CAUTION:**

**Do not allow the coolant container to get too low when filling, to avoid air from being drawn into the cooling system.**

11. Remove the Tool from the radiator neck opening and install the radiator cap.

12. Remove the non-vented reservoir cap.

13. Fill the cooling system reservoir tank to the specified level. Run the engine to warm up the cooling system and top up the system as necessary before installing the vented reservoir cap.

14. Install the engine under cover. Refer to [EXT-15. "Removal and Installation"](#).

## FLUSHING COOLING SYSTEM

1. Drain the water from the engine cooling system. Refer to [CO-40, "Changing Engine Coolant"](#).

2. Fill the radiator and the reservoir tank (to the "MAX" line), with water. Reinstall the radiator cap and leave the vented reservoir cap off.

3. Run the engine until it reaches normal operating temperature.

4. Press the engine accelerator two or three times under no-load.

5. Stop the engine and wait until it cools down.

6. Drain the water from the engine cooling system. Refer to [CO-40, "Changing Engine Coolant"](#).

7. Repeat steps 2 through 6 until clear water begins to drain from the radiator.

# RADIATOR

< REMOVAL AND INSTALLATION >

[VQ40DE]

## REMOVAL AND INSTALLATION

### RADIATOR

#### Exploded View

INFOID:000000007323385

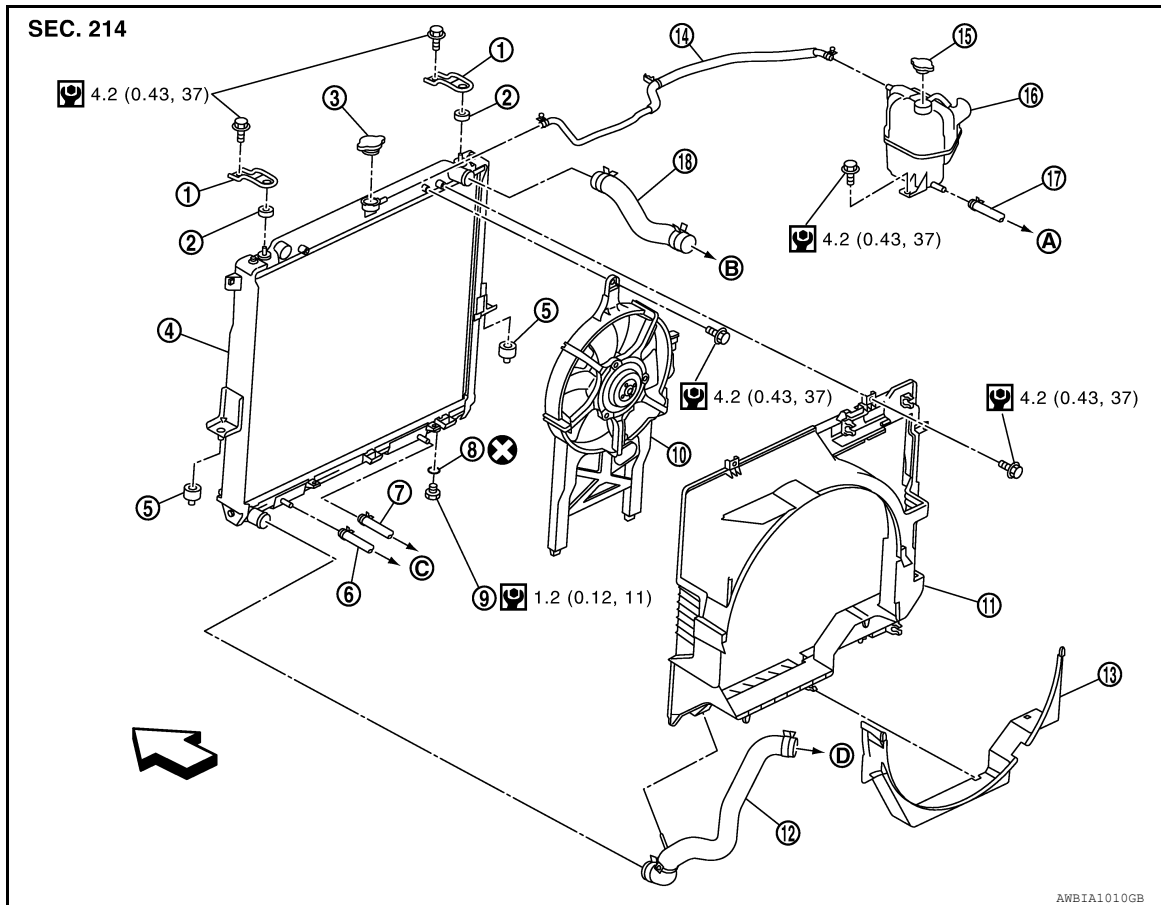

- |  |                             |                           |
|--|-----------------------------|---------------------------|
| 1. Radiator mounting bracket                 | 2. Mounting rubber (upper)  | 3. Radiator cap           |
| 4. Radiator                                  | 5. Mounting rubber (lower)  | 6. A/T fluid cooler hose  |
| 7. A/T fluid cooler hose (if equipped)       | 8. O-ring                   | 9. Drain plug             |
| 10. Cooling fan assembly (Motor driven type) | 11. Radiator shroud (upper) | 12. Radiator hose (lower) |
| 13. Radiator shroud (lower)                  | 14. Reservoir tank hose     | 15. Reservoir tank cap    |
| 16. Reservoir tank                           | 17. Water hose              | 18. Radiator hose (upper) |
| A. To heater return tube                     | B. To water pipe            | C. To A/T cooler tube     |
| D. To water inlet and thermostat assembly    | ← Vehicle front             |                           |

### Removal and Installation

INFOID:000000007323386

#### **WARNING:**

Never remove the radiator cap when the engine is hot. Serious burns could occur from high pressure engine coolant escaping from the radiator. Wrap a thick cloth around the cap. Slowly turn it a quarter of a turn to release built-up pressure. Carefully remove radiator cap by turning it all the way.

#### **NOTE:**

When removing components such as hoses, tubes/lines, etc., cap or plug openings to prevent fluid from spilling.

#### REMOVAL

1. Remove engine under cover. Refer to [EXT-15, "Removal and Installation"](#).

# RADIATOR

[VQ40DE]

## < REMOVAL AND INSTALLATION >

2. Drain engine coolant from radiator. Refer to [CO-39](#).  
**CAUTION:**
  - Perform this step when engine is cold.
  - Do not spill engine coolant on drive belts.
3. Remove engine room cover. Refer to [EM-139](#), "Removal and Installation".
4. Remove air duct and resonator assembly and air cleaner case (upper). Refer to [EM-140](#), "Removal and Installation".
5. Remove reservoir tank hose from radiator.
6. Remove PCV hose.
7. Remove radiator hoses (upper and lower).  
**CAUTION:**  
**Be careful not to allow engine coolant to contact drive belts.**
8. Disconnect A/T fluid cooler hoses, if equipped.
9. Remove engine cooling fan (Motor driven type). Refer to [CO-48](#), "Removal and Installation (Motor driven type)".
10. Remove front grille. Refer to [EXT-23](#), "Removal and Installation".
11. Remove the upper radiator mounting bracket bolts.

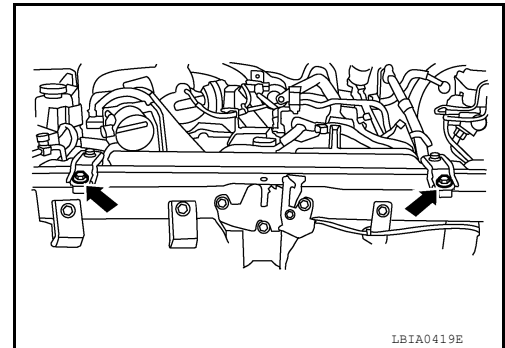

12. Remove the two A/C condenser bolts.

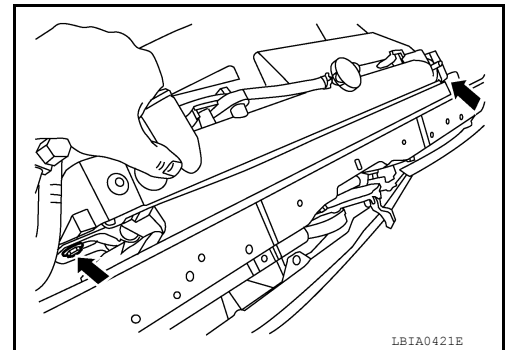

13. Remove radiator as follows:

**CAUTION:**

**Do not damage or scratch A/C condenser and radiator core when removing.**

- a. Lift and pull radiator rearward to disengage mounting rubber (lower) from radiator core support center.

**CAUTION:**

**Because A/C condenser is attached to the front-lower portion of radiator, moving it in the rear direction should be at a minimum.**

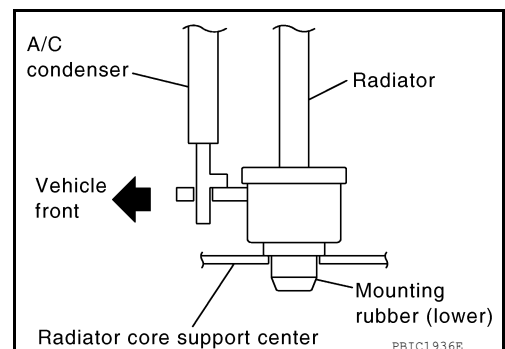

# RADIATOR

[VQ40DE]

## < REMOVAL AND INSTALLATION >

- b. Lift A/C condenser up and remove radiator after disengaging the fitting at front-bottom surface.

**CAUTION:**

**Lifting A/C condenser should be minimum to prevent a load to A/C piping.**

- c. After removing radiator, put A/C condenser on radiator core support center and temporarily fasten it with rope or wire to prevent overloading the A/C piping.

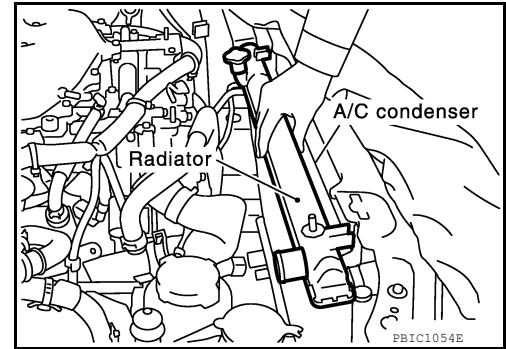

## INSTALLATION

Installation is in the reverse order of removal.

## INSPECTION AFTER INSTALLATION

- Check for engine coolant leaks. Refer to [CO-39. "System Inspection"](#).
- Start and warm up engine. Visually check for engine coolant and A/T fluid leaks. Repair as necessary.
- Check and adjust engine coolant level and A/T fluid (if equipped). Refer to [MA-18. "FOR USA AND CANADA : Fluids and Lubricants"](#) (United States and Canada) or [MA-20. "FOR MEXICO : Fluids and Lubricants"](#) (Mexico).

# ENGINE COOLING FAN

< REMOVAL AND INSTALLATION >

[VQ40DE]

## ENGINE COOLING FAN

### Exploded View

INFOID:000000007323388

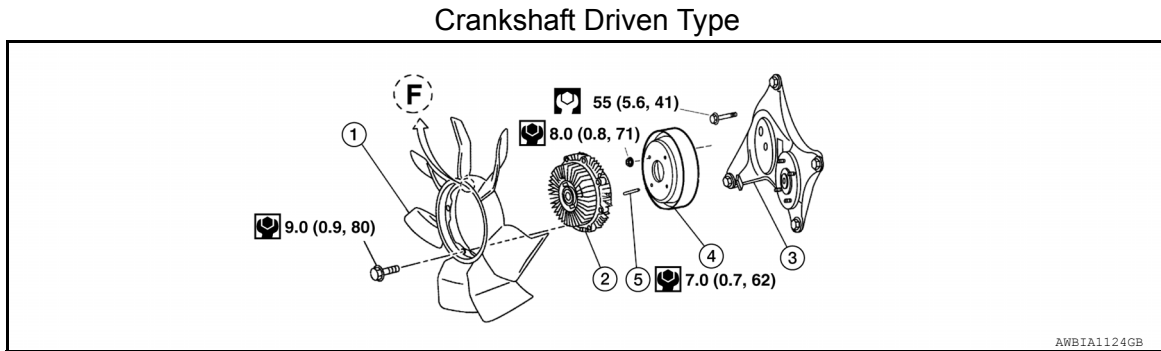

- |                       |                 |                |
|-----------------------|-----------------|----------------|
| 1. Cooling fan        | 2. Fan coupling | 3. Fan bracket |
| 4. Cooling fan pulley | 5. Stud         | F. Front mark  |

### Removal and Installation (Crankshaft driven type)

INFOID:000000007323389

#### **WARNING:**

Never remove the radiator cap when the engine is hot. Serious burns could occur from high pressure engine coolant escaping from the radiator. Wrap a thick cloth around the cap. Slowly turn it a quarter of a turn to release built-up pressure. Carefully remove radiator cap by turning it all the way.

#### **NOTE:**

When removing components such as hoses, tubes/lines, etc., cap or plug openings to prevent fluid from spilling.

#### REMOVAL

1. Remove the engine cooling fan (Motor driven type). Refer to [CO-48. "Removal and Installation \(Motor driven type\)"](#).
2. Remove reservoir tank hose from shroud.
3. Remove radiator hose (upper) from radiator.  
**CAUTION:**  
**Do not spill engine coolant on drive belts.**
4. Release the radiator shroud (lower) (2) from the radiator shroud (upper) (1) and position aside.
  - Release the tabs, pull radiator shroud (lower) (2) rearwards and down.

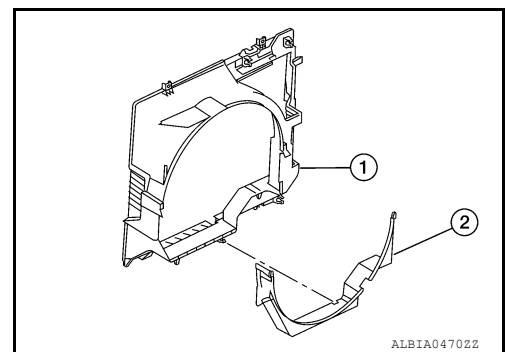

5. Remove the radiator shroud (upper) bolts and remove the radiator shroud (upper). Refer to [CO-44. "Exploded View"](#).
6. Remove the drive belt. Refer to [EM-128. "Removal and Installation"](#).
7. Remove the engine cooling fan.
8. Remove the fan coupling, if necessary.
9. Remove the cooling fan pulley, if necessary.
10. Remove the drive belt auto-tensioner, if necessary.
11. Remove the fan bracket, if necessary.

#### INSPECTION AFTER REMOVAL

# ENGINE COOLING FAN

< REMOVAL AND INSTALLATION >

[VQ40DE]

## Fan Coupling

- Inspect fan coupling for oil leakage and bimetal conditions.
- If there are any concerns replace the fan coupling.

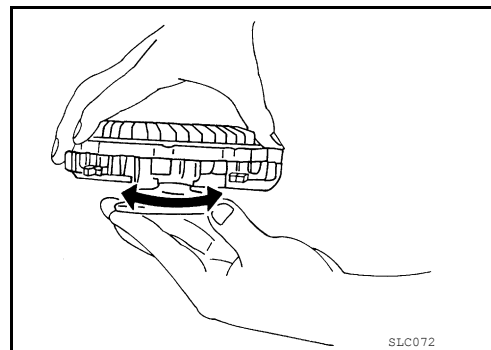

## Fan Bracket

- Check that the fan bracket shaft turns smoothly by hand and is not excessively loose.
- If there are any concerns replace the fan bracket assembly.

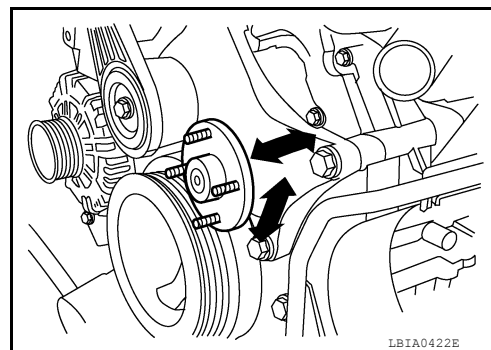

## INSTALLATION

Installation is in the reverse order of removal.

- Install cooling fan with its front mark "F" facing front of engine. Refer to [CO-47. "Exploded View"](#).

## INSPECTION AFTER INSTALLATION

- Check for engine coolant leaks. Refer to [CO-39. "System Inspection"](#).
- Start and warm up the engine. Visually check for engine coolant leaks. Repair as necessary.

## Removal and Installation (Motor driven type)

INFOID:000000007323390

### NOTE:

When removing components such as hoses, tubes/lines, etc., cap or plug openings to prevent fluid from spilling.

## REMOVAL

1. Remove the engine under cover. Refer to [EXT-15. "Removal and Installation"](#).
2. Partially drain engine coolant from radiator. Refer to [CO-40. "Changing Engine Coolant"](#).

### CAUTION:

- Perform this step when engine is cold.
  - Do not spill engine coolant on drive belts.
3. Release the radiator shroud (lower) (2) from the radiator shroud (upper) (1) and position aside.
    - Release the tabs, pull radiator shroud (lower) (2) rearwards and down.

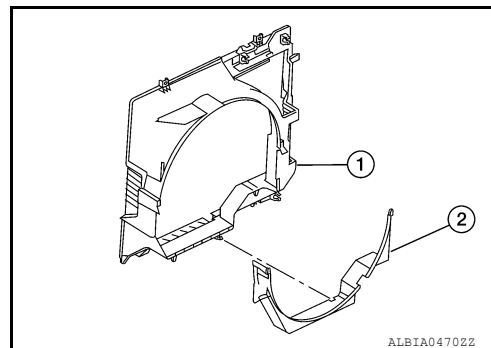

4. Remove engine room cover. Refer to [EM-139. "Removal and Installation"](#).
5. Remove air duct and resonator assembly. Refer to [EM-140. "Removal and Installation"](#).



# ENGINE COOLING FAN

[VQ40DE]

## < REMOVAL AND INSTALLATION >

6. Remove upper radiator hose from radiator.
7. Remove reservoir tank hose from radiator shroud (upper) and radiator.
8. Remove the radiator shroud (upper) bolts and remove the radiator shroud (upper). Refer to [CO-44, "Exploded View"](#).
9. Disconnect harness connector from fan motor.
10. Remove the bolt and remove the fan grille and motor assembly.

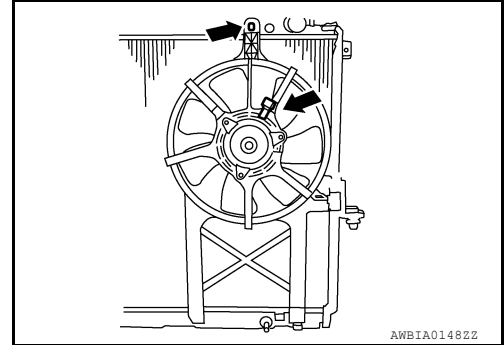

## INSTALLATION

Installation is in the reverse order of removal.

- Cooling fan is controlled by ECM. For details, refer to [EC-815, "Diagnosis Procedure"](#).

A  
CO  
C  
D  
E  
F  
G  
H  
I  
J  
K  
L  
M  
N  
O  
P

# WATER PUMP

< REMOVAL AND INSTALLATION >

[VQ40DE]

## WATER PUMP

### Exploded View

INFOID:000000007323391

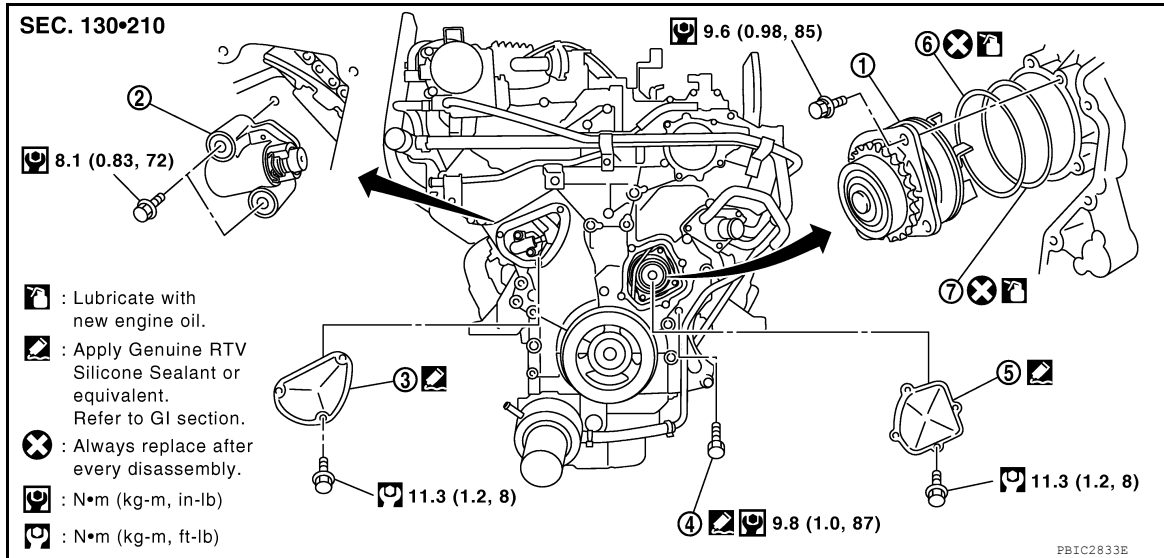

- |                             |                                     |                          |
|-----------------------------|-------------------------------------|--------------------------|
| 1. Water pump               | 2. Timing chain tensioner (primary) | 3. Chain tensioner cover |
| 4. Water drain plug (front) | 5. Water pump cover                 | 6. O-ring                |
| 7. O-ring                   |                                     |                          |

### Removal and Installation

INFOID:000000007323392

#### WARNING:

Never remove the radiator cap when the engine is hot. Serious burns could occur from high pressure engine coolant escaping from the radiator. Wrap a thick cloth around the cap. Slowly turn it a quarter of a turn to release built-up pressure. Carefully remove radiator cap by turning it all the way.

#### CAUTION:

- When removing water pump assembly, be careful not to get engine coolant on timing chain and drive belt.
- Water pump cannot be disassembled and should be replaced as a unit.
- After installing water pump, connect hose and clamp securely, then check for leaks.

#### REMOVAL

1. Drain engine coolant from radiator. Refer to [CO-39](#).
  - CAUTION:**
    - Perform this step when engine is cold.
    - Do not spill engine coolant on timing chain and drive belt.
2. Remove water drain plug (front) (1) on the water pump side of the cylinder block.

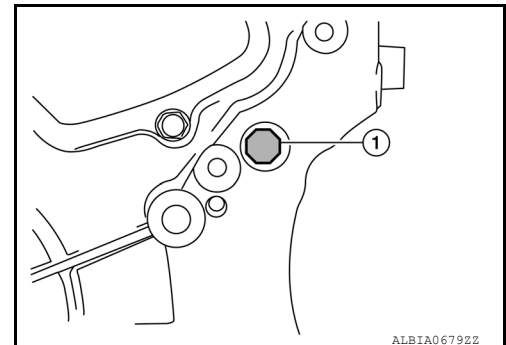

3. Remove coolant reservoir hose from the radiator.

# WATER PUMP

[VQ40DE]

## < REMOVAL AND INSTALLATION >

4. Remove engine cooling fan (Motor driven type). Refer to [CO-48. "Removal and Installation \(Motor driven type\)"](#).
5. Remove engine cooling fan (Crankshaft driven type) and fan bracket. Refer to [CO-47. "Removal and Installation \(Crankshaft driven type\)"](#).
6. Set No. 1 cylinder at TDC.
  - Rotate crankshaft pulley clockwise to align timing mark (A) (grooved line without color) with timing indicator (B).

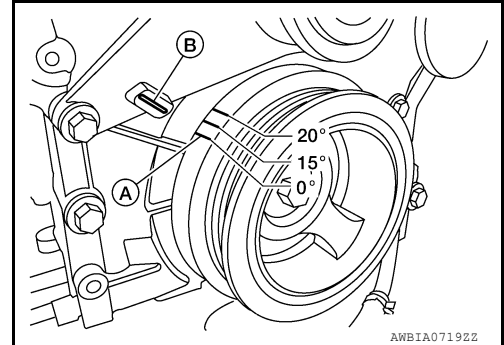

7. Remove chain tensioner cover and water pump cover from front timing chain case, using Tool.

**Tool number : KV10111100 (J-37228)**

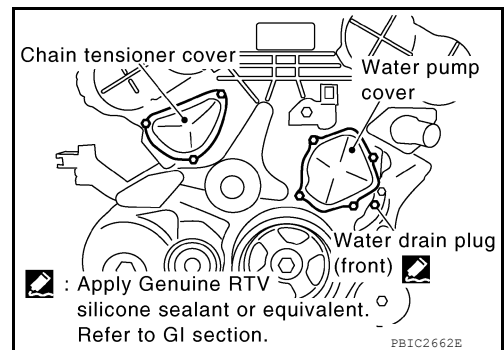

8. Remove timing chain tensioner (primary) as follows:
  - a. Loosen clip of timing chain tensioner (primary), and release plunger stopper (1).
  - b. Insert plunger into tensioner body by pressing slack guide (2).
  - c. Keep slack guide pressed and hold plunger in by pushing stopper pin through the tensioner body hole and plunger groove (3).

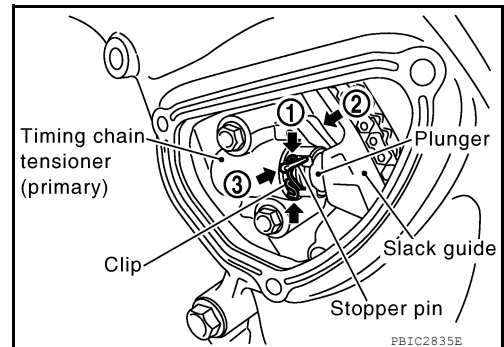

- d. Turn crankshaft pulley clockwise so that timing chain on the timing chain tensioner (primary) side is loose.

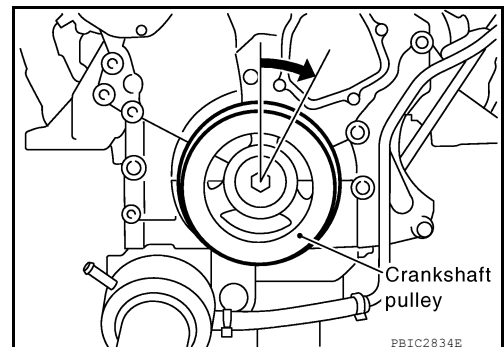

# WATER PUMP

[VQ40DE]

## < REMOVAL AND INSTALLATION >

- e. Remove bolts and remove timing chain tensioner (primary).

**CAUTION:**

Be careful not to drop bolts inside timing chain case.

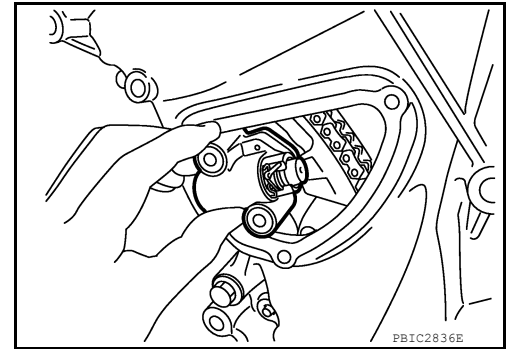

9. Remove water pump as follows:

- a. Remove three water pump bolts. Secure a gap between water pump gear and timing chain, by turning crankshaft pulley counterclockwise until timing chain looseness on water pump sprocket becomes maximum.

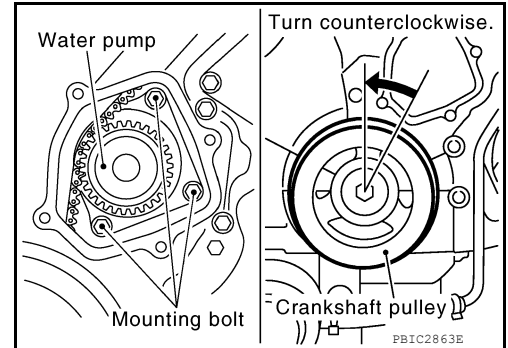

- b. Screw M8 bolts [pitch: 1.25 mm (0.049 in) length: approx. 50 mm (1.97 in)] into water pump upper and lower bolt holes until they reach timing chain case. Then, alternately tighten each bolt for a half turn, and pull out water pump.

**CAUTION:**

- Place a suitable shop cloth below the water pump housing to prevent any engine coolant from dripping into the timing chain case.
- Pull water pump straight out while preventing vane from contacting socket in installation area.
- Remove water pump without causing sprocket to contact timing chain.

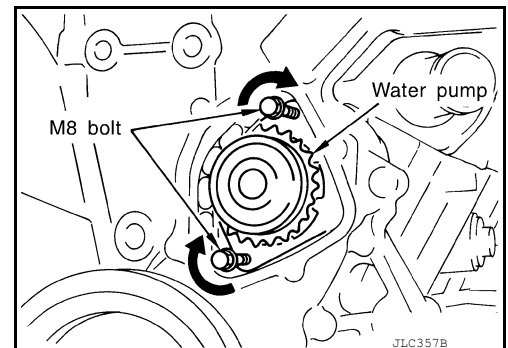

- c. Remove M8 bolts and O-rings from water pump.

**CAUTION:**

- Do not disassemble water pump.
- Do not reuse O-rings.

## INSPECTION AFTER REMOVAL

- Check for badly rusted or corroded water pump body assembly.
- Check for rough operation due to excessive end play.
- Replace water pump, if necessary.

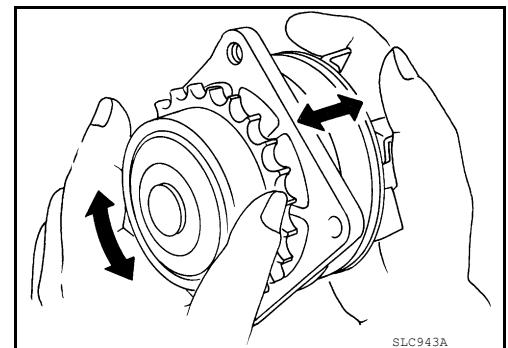

## INSTALLATION

1. Install new O-rings to water pump.

**CAUTION:**

Do not reuse O-rings.

**NOTE:**

# WATER PUMP

[VQ40DE]

## < REMOVAL AND INSTALLATION >

- Apply engine oil to O-rings.
- Locate O-ring with white paint mark to engine front side.

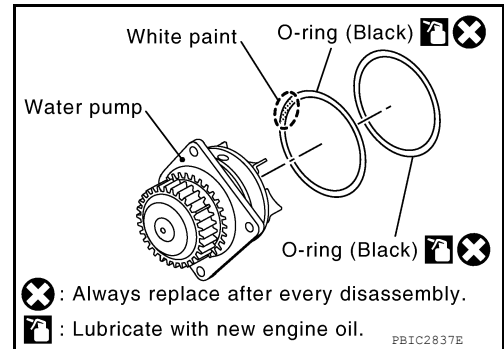

2. Hold timing chain to the side (←) and install water pump (←).

**CAUTION:**

**Do not allow timing chain case to pinch O-rings when installing water pump.**

- Make sure that timing chain and water pump sprocket are engaged.
- Tighten water pump bolts alternately and evenly.

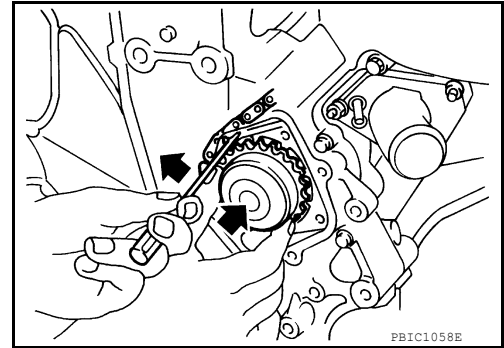

3. Remove dust and foreign material completely from installation area of timing chain tensioner (primary) and rear timing chain case.
4. Turn crankshaft pulley approximately 20° clockwise so that timing chain on the timing chain tensioner (primary) side is loose.

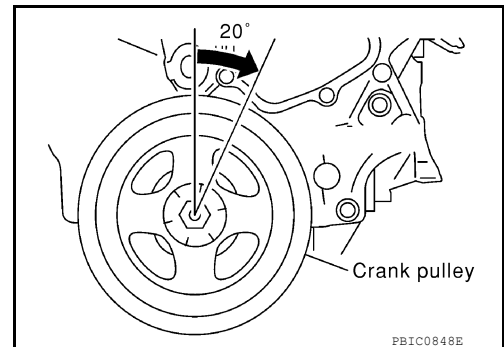

5. Install timing chain tensioner (primary) with its stopper pin inserted.

**CAUTION:**

**Be careful not to drop bolts inside timing chain case.**

6. Remove stopper pin.
- Make sure again that timing chain and water pump sprocket are engaged.

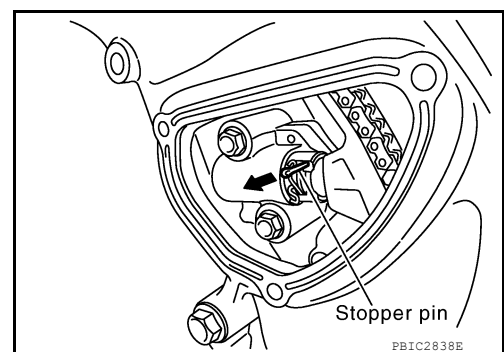

7. Install chain tensioner cover and water pump cover.

# WATER PUMP

[VQ40DE]

## < REMOVAL AND INSTALLATION >

- a. Before installing, remove all traces of old liquid gasket from mating surface of water pump cover and chain tensioner cover using scraper. Also remove traces of old liquid gasket from the mating surface of front timing chain case.

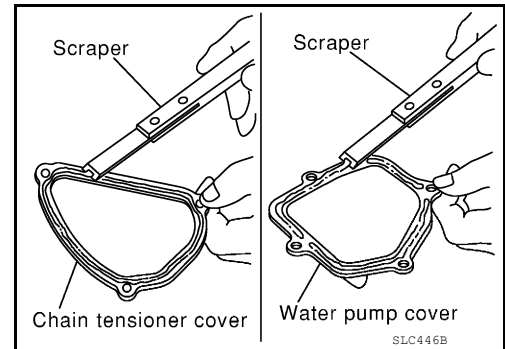

- b. Apply a continuous bead of liquid gasket, to mating surface of chain tensioner and water pump cover, using Tool.

**Tool number : WS39930000 ( — )**

**Use Genuine RTV Silicone Sealant or equivalent. Refer to [GI-22, "Recommended Chemical Products and Sealants"](#).**

**CAUTION:**

- Installation should be done within 5 minutes after applying liquid gasket.
- Do not fill the engine with oil for at least 30 minutes after the components are installed to allow the sealant to cure.

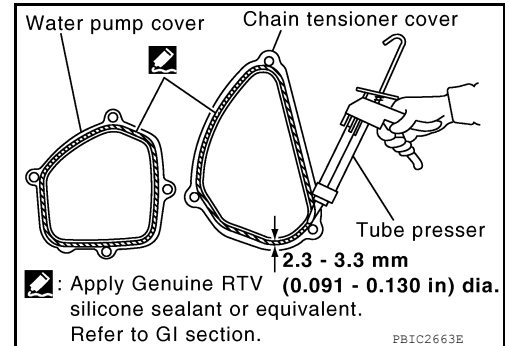

- c. Tighten bolts to specified torque. Refer to [CO-50, "Exploded View"](#).

8. Install water drain plug (front) (1) on water pump side of cylinder block.

- Apply liquid gasket to the thread of water drain plug (front).  
**Use Genuine RTV Silicone Sealant or equivalent. Refer to [GI-22, "Recommended Chemical Products and Sealants"](#).**

**Water drain plug (front) : 9.8 N·m (1.0 kg·m, 87 in·lb)**

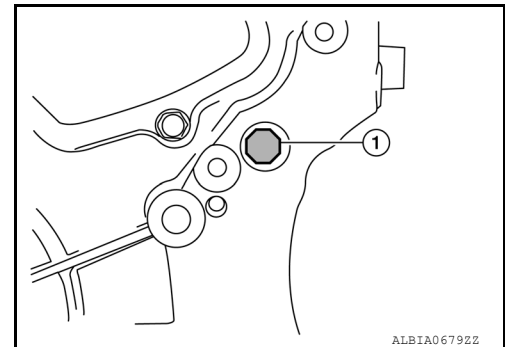

9. Installation of the remaining components is in the reverse order of removal.
- After installation refill engine coolant and check for leaks. Refer to [CO-40, "Changing Engine Coolant"](#) and [CO-39, "System Inspection"](#).

**CAUTION:**

**Do not spill coolant in the engine compartment. Use a shop cloth to absorb coolant.**

- After starting engine, let idle for three minutes, then rev engine up to 3,000 rpm under no load to purge air from the high-pressure chamber of the chain tensioner. The engine may produce a rattling noise. This indicates that air still remains in the chamber and is not a matter of concern.

## INSPECTION AFTER INSTALLATION

- Check for engine coolant leaks. Refer to [CO-39, "System Inspection"](#).
- Start and warm up engine. Visually check for engine coolant leaks. Repair as necessary.

# WATER INLET AND THERMOSTAT ASSEMBLY

< REMOVAL AND INSTALLATION >

[VQ40DE]

## WATER INLET AND THERMOSTAT ASSEMBLY

Exploded View

INFOID:000000007323393

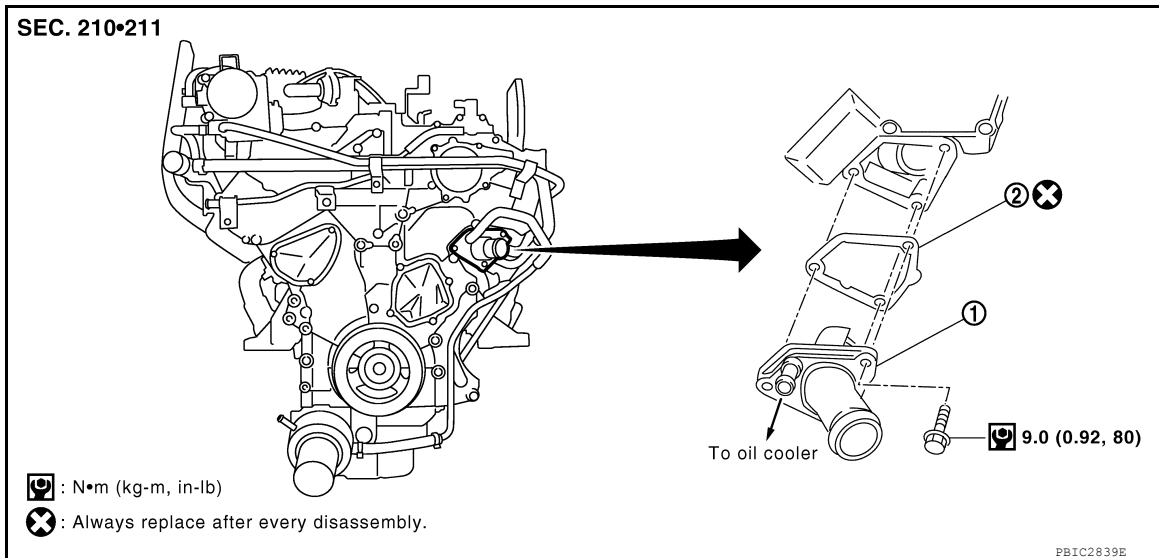

1. Water inlet and thermostat assembly
2. Gasket

## Removal and Installation

INFOID:000000007323394

### WARNING:

Never remove the radiator cap when the engine is hot. Serious burns could occur from high pressure engine coolant escaping from the radiator. Wrap a thick cloth around the cap. Slowly turn it a quarter of a turn to release built-up pressure. Carefully remove radiator cap by turning it all the way.

### NOTE:

When removing components such as hoses, tubes/lines, etc., cap or plug openings to prevent fluid from spilling.

### REMOVAL

1. Remove engine cooling fan (Motor driven type). Refer to [CO-48. "Removal and Installation \(Motor driven type\)"](#)
2. Disconnect radiator hose (lower) and oil cooler hose from water inlet and thermostat assembly.
3. Remove water inlet and thermostat assembly.

### CAUTION:

- Do not disassemble water inlet and thermostat assembly.
- Replace water inlet and thermostat assembly as a unit.

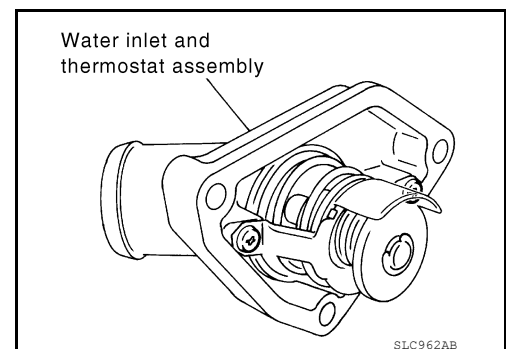

### INSPECTION AFTER REMOVAL

1. Check valve seating condition at room temperature. It should seat tightly.

# WATER INLET AND THERMOSTAT ASSEMBLY

[VQ40DE]

## < REMOVAL AND INSTALLATION >

2. Check valve operation.
  - Place a thread so that it is caught in the valve of the thermostat. Immerse fully in a container filled with water. Heat while stirring.
  - The valve opening temperature is the temperature at which the valve opens and falls from the thread.
  - Continue heating. Check the full-open lift amount.

**NOTE:**  
The full-open lift amount standard temperature is the reference value.

  - After checking the full-open lift amount, lower the water temperature and check the valve closing temperature.

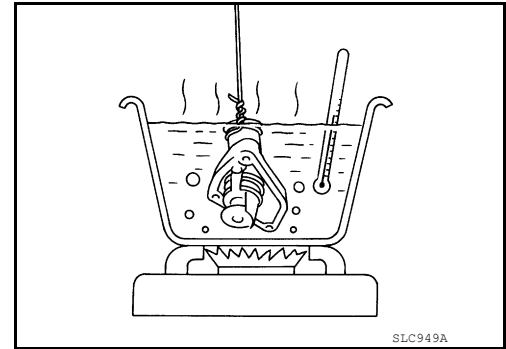

Thermostat	Standard
Valve opening temperature	Refer to <a href="#">CO-59. "Standard and Limit"</a>
Full-open lift amount	Refer to <a href="#">CO-59. "Standard and Limit"</a>
Valve closing temperature	Refer to <a href="#">CO-59. "Standard and Limit"</a>

If out of the specification range, replace water inlet and thermostat assembly.

## INSTALLATION

Installation is in the reverse order of removal.

### **CAUTION:**

**Do not spill engine coolant in engine room. Use shop cloth to absorb engine coolant.**

## INSPECTION AFTER INSTALLATION

- Check for engine coolant leaks. Refer to [CO-39. "System Inspection"](#).
- Start and warm up engine. Visually check for engine coolant leaks. Repair as necessary.



# WATER OUTLET AND WATER PIPING

< REMOVAL AND INSTALLATION >

[VQ40DE]

## WATER OUTLET AND WATER PIPING

Exploded View

INFOID:000000007323395

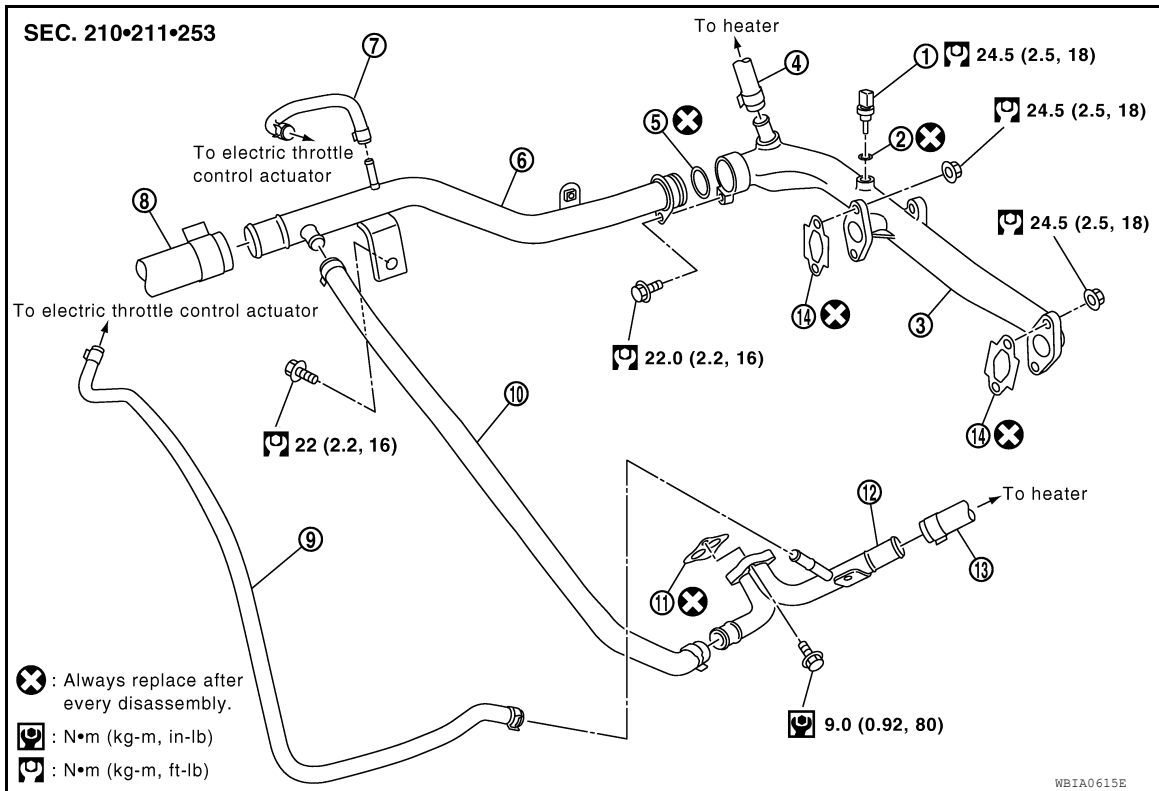

- |                                      |                          |                 |
|--------------------------------------|--------------------------|-----------------|
| 1. Engine coolant temperature sensor | 2. Washer                | 3. Water outlet |
| 4. Heater hose                       | 5. O-ring                | 6. Water pipe   |
| 7. Water hose                        | 8. Radiator hose (upper) | 9. Water hose   |
| 10. Water hose                       | 11. Gasket               | 12. Heater pipe |
| 13. Heater hose                      | 14. Gasket               |                 |

## Removal and Installation

INFOID:000000007323396

### WARNING:

Never remove the radiator cap when the engine is hot. Serious burns could occur from high pressure engine coolant escaping from the radiator. Wrap a thick cloth around the cap. Slowly turn it a quarter of a turn to release built-up pressure. Carefully remove radiator cap by turning it all the way.

### NOTE:

When removing components such as hoses, tubes/lines, etc., cap or plug openings to prevent fluid from spilling.

### REMOVAL

1. Drain engine coolant from radiator. Refer to [CO-40, "Changing Engine Coolant"](#).

#### CAUTION:

- Perform this step when engine is cold.
- Do not spill engine coolant on drive belts.

2. Remove the intake manifold collector. Refer to [EM-141, "Removal and Installation"](#).
3. Remove engine coolant temperature sensor as necessary.

#### CAUTION:

Be careful not to damage engine coolant temperature sensor.

4. Remove water outlet, heater pipe, water bypass hoses and water pipe.

### INSTALLATION

## WATER OUTLET AND WATER PIPING

[VQ40DE]

### < REMOVAL AND INSTALLATION >

---

Installation is in the reverse order of removal, paying attention to the following.

- Securely insert each hose, and install clamp at a position where it does not interfere with the pipe bulge.
- Before inserting water pipe into water outlet, apply mild soap to O-ring.

**CAUTION:**

**Do not reuse O-ring.**

### INSPECTION AFTER INSTALLATION

- Check for engine coolant leaks. Refer to [CO-39. "System Inspection"](#).
- Start and warm up engine. Visually check for engine coolant leaks. Repair as necessary.

# SERVICE DATA AND SPECIFICATIONS (SDS)

< SERVICE DATA AND SPECIFICATIONS (SDS)

[VQ40DE]

## SERVICE DATA AND SPECIFICATIONS (SDS)

### SERVICE DATA AND SPECIFICATIONS (SDS)

#### Standard and Limit

INFOID:000000007323397

A

CO

#### ENGINE COOLANT CAPACITY (APPROXIMATE)

Unit: ℓ (US qt, Imp qt)

Engine coolant capacity (With reservoir tank at "MAX" level)	10.2 (10-3/4, 9)
--	------------------

C

#### RADIATOR

Unit: kPa (kg/cm<sup>2</sup>, psi)

Reservoir cap relief pressure	Standard	98 - 118 (1.0 - 1.2, 14 - 17)
Leak testing pressure		157 (1.6, 23)

D

E

#### THERMOSTAT

Valve opening temperature	80.5 - 83.5°C (177 - 182°F)
Full-open lift amount	8.6 mm / 95°C (0.339 in / 203°F)
Valve closing temperature	77°C (171°F)

F

G

H

I

J

K

L

M

N

O

P