

SECTION **EXT**
EXTERIOR

A
B
C
D
E
F
G
H
I
J
L
M
N
O
P

CONTENTS

PRECAUTION	2	FRONT GRILLE	23
PRECAUTIONS	2	Removal and Installation	23
Precaution for Supplemental Restraint System (SRS) "AIR BAG" and "SEAT BELT PRE-TENSIONER"	2	COWL TOP	24
Service Notice	2	Removal and Installation	24
Precaution for Procedure without Cowl Top Cover.....	2	FRONT FENDER	25
Precaution for Work	3	Removal and Installation	25
PREPARATION	4	FENDER PROTECTOR	26
PREPARATION	4	Component	26
Special Service Tool	4	Removal and Installation of Front Fender Protector	27
Commercial Service Tool	4	Removal and Installation of Rear Fender Protector	28
CLIP LIST	5	MUDGUARD	29
Descriptions for Clips	5	Removal and Installation	29
PERIODIC MAINTENANCE	9	RUNNING BOARDS	30
SQUEAK AND RATTLE TROUBLE DIAGNOSES	9	Removal and Installation	30
Work Flow	9	ROOF RACK	32
Generic Squeak and Rattle Troubleshooting	11	Removal and Installation	32
Diagnostic Worksheet	13	DOOR OUTSIDE MOLDING	33
REMOVAL AND INSTALLATION	15	Removal and Installation	33
FRONT BUMPER	15	SIDE GUARD MOLDING	34
Removal and Installation	15	Removal and Installation	34
REAR BUMPER	21	BED RAILS AND TRIM	36
Removal and Installation	21	Removal and Installation	36
		TAIL GATE FINISHER	38
		Removal and Installation	38

EXT

PRECAUTIONS

< PRECAUTION >

PRECAUTION

PRECAUTIONS

Precaution for Supplemental Restraint System (SRS) "AIR BAG" and "SEAT BELT PRE-TENSIONER"

INFOID:000000007328493

The Supplemental Restraint System such as "AIR BAG" and "SEAT BELT PRE-TENSIONER", used along with a front seat belt, helps to reduce the risk or severity of injury to the driver and front passenger for certain types of collision. This system includes seat belt switch inputs and dual stage front air bag modules. The SRS system uses the seat belt switches to determine the front air bag deployment, and may only deploy one front air bag, depending on the severity of a collision and whether the front occupants are belted or unbelted. Information necessary to service the system safely is included in the SR and SB section of this Service Manual.

WARNING:

- To avoid rendering the SRS inoperative, which could increase the risk of personal injury or death in the event of a collision which would result in air bag inflation, all maintenance must be performed by an authorized NISSAN/INFINITI dealer.
- Improper maintenance, including incorrect removal and installation of the SRS, can lead to personal injury caused by unintentional activation of the system. For removal of Spiral Cable and Air Bag Module, see the SR section.
- Do not use electrical test equipment on any circuit related to the SRS unless instructed to in this Service Manual. SRS wiring harnesses can be identified by yellow and/or orange harnesses or harness connectors.

PRECAUTIONS WHEN USING POWER TOOLS (AIR OR ELECTRIC) AND HAMMERS

WARNING:

- When working near the Airbag Diagnosis Sensor Unit or other Airbag System sensors with the Ignition ON or engine running, DO NOT use air or electric power tools or strike near the sensor(s) with a hammer. Heavy vibration could activate the sensor(s) and deploy the air bag(s), possibly causing serious injury.
- When using air or electric power tools or hammers, always switch the Ignition OFF, disconnect the battery, and wait at least 3 minutes before performing any service.

Service Notice

INFOID:000000007328494

- When removing or installing various parts, place a cloth or padding on the vehicle body to prevent scratches.
- Handle trim, molding, instruments, grille, etc. carefully during removing or installing. Be careful not to soil or damage them.
- Apply sealing compound where necessary when installing parts.
- When applying sealing compound, be careful that the sealing compound does not protrude from parts.
- When replacing any metal parts (for example body outer panel, members, etc.), be sure to take rust prevention measures.

Precaution for Procedure without Cowl Top Cover

INFOID:000000007328495

When performing the procedure after removing cowl top cover, cover the lower end of windshield with urethane, etc.

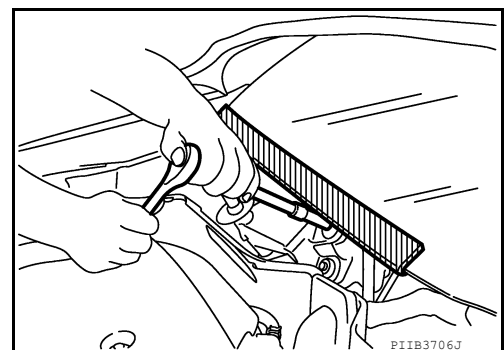

PRECAUTIONS

< PRECAUTION >

Precaution for Work

INFOID:000000007328496

- When removing or disassembling each component, be careful not to damage or deform it. If a component may be subject to interference, be sure to protect it with a shop cloth.
- When removing (disengaging) components with a screwdriver or similar tool, be sure to wrap the component with a shop cloth or vinyl tape to protect it.
- Protect the removed parts with a shop cloth and prevent them from being dropped.
- Replace a deformed or damaged clip.
- If a part is specified as a non-reusable part, always replace it with new one.
- Be sure to tighten bolts and nuts securely to the specified torque.
- After installation is complete, be sure to check that each part works properly.
- Follow the steps below to clean components.
 - Water soluble dirt: Dip a soft cloth into lukewarm water, and wring the water out of the cloth to wipe the dirty area.
Then rub with a soft and dry cloth.
 - Oily dirt: Dip a soft cloth into lukewarm water with mild detergent (concentration: within 2 to 3%), and wipe the dirty area.
Then dip a cloth into fresh water, and wring the water out of the cloth to wipe the detergent off. Then rub with a soft and dry cloth.
- Do not use organic solvent such as thinner, benzene, alcohol, or gasoline.
- For genuine leather seats, use a genuine leather seat cleaner.

A
B
C
D
E
F
G
H
I
J
L
M
N
O
P

EXT

PREPARATION

< PREPARATION >

PREPARATION

PREPARATION

Special Service Tool

INFOID:000000007328497

The actual shapes of Kent-Moore tools may differ from those of special service tools illustrated here.

Tool number (Kent-Moore No.) Tool name	Description
— (J-39570) Chassis ear	Locating the noise
— (J-43980) NISSAN Squeak and Rattle kit	Repairing the cause of noise
— (J-46534) Trim Tool Set	Removing trim components

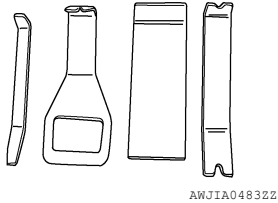
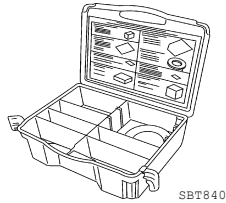
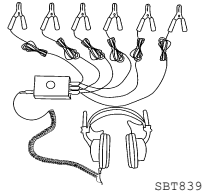

Commercial Service Tool

INFOID:000000007328498

(Kent-Moore No.) Tool name	Description
(J-39565) Engine ear	Locating the noise

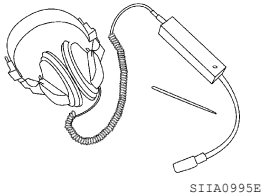

CLIP LIST







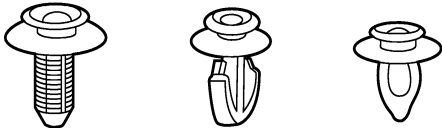

< PREPARATION >

CLIP LIST

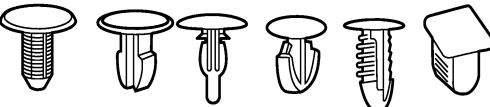
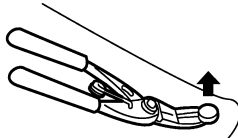
Descriptions for Clips

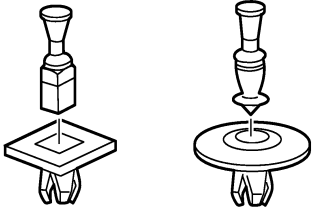
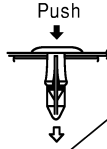
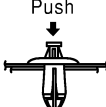
INFOID:000000007831502

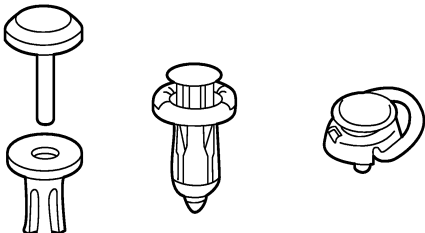
Replace any clips which are damaged during removal or installation.

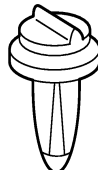
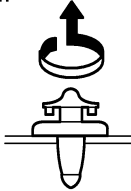





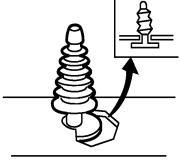
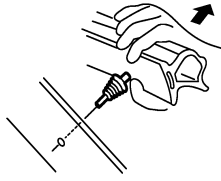

Symbol No.	Shapes	Removal & Installation
C101 		<p>Removal: Remove by bending up with flat-bladed screwdrivers or clip remover.</p> 
C103 		 <p>Removal: Remove with a clip remover.</p>
C203 		<p>Removal: Push center pin to catching position. (Do not remove center pin by hitting it.)</p> <p>Push</p>  <p>Installation:</p> <p>Push</p> 
C205 		<p>Removal: Flat-bladed screwdriver</p>  <p>Clip</p> <p>Finisher</p>
C206 		<p>Removal:</p> 

SIIA0315E

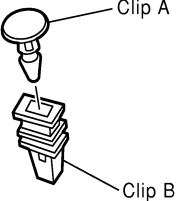
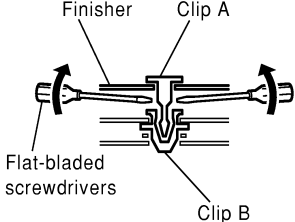
A
B
C
D
E
F
G
H
I
J
EXT
L
M
N
O
P

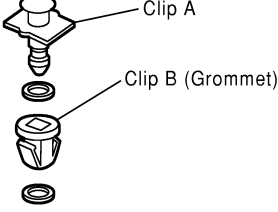
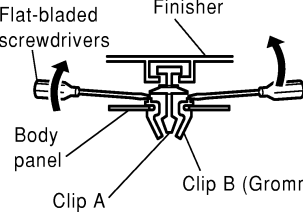
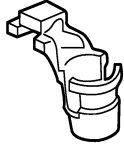
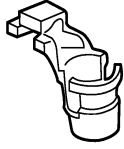
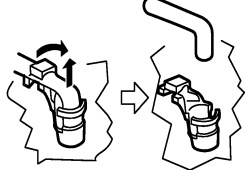
CLIP LIST

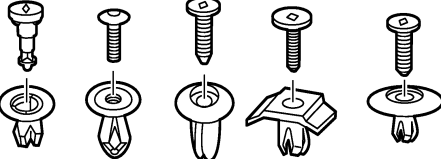









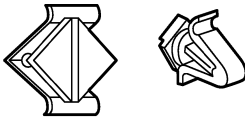

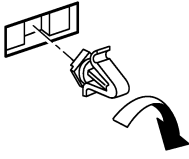
< PREPARATION >

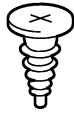
Symbol No.	Shapes	Removal & Installation
<p>CE103</p> 		<p>Removal:</p> 
<p>CF110</p> 		<p>Removal:</p> 
<p>CF118</p> 		<p>Removal:</p> 
<p>CR103</p> 		<p>Removal: Holder portion of clip must be spread out to remove rod.</p> 
<p>CS101</p> 		<p>Removal:</p> <ol style="list-style-type: none"> 1. Screw out with a Phillips screwdriver. 2. Remove female portion with flat-bladed screwdriver. 

SIIA0316E

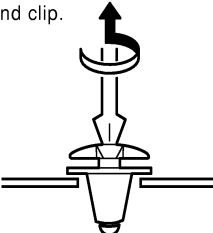
CLIP LIST

< PREPARATION >





Symbol No.	Shapes	Removal & Installation	
CG101 		Removal:  Rotate 45° to remove	Installation: 
CS102 			
CS113 		Removal: Disconnect upper connection of clip with a flat-bladed screwdriver, then remove clip while inserting a flat-bladed screwdriver between body panel and clip. 	
C111 			

SIIA0317E

A
B
C
D
E
F
G
H
I
J
EXT
L
M
N
O
P

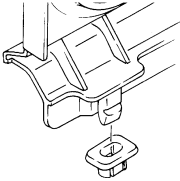
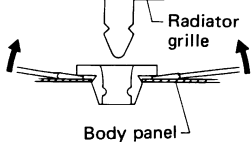
CLIP LIST

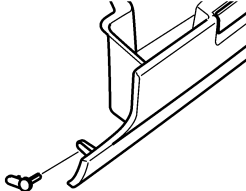
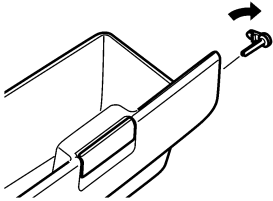
< PREPARATION >

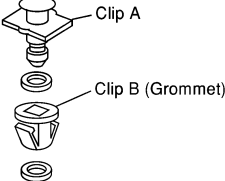
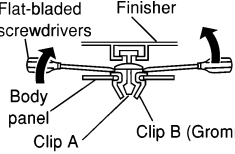
Symbol No.	Shapes	Removal & Installation
<p>CG104</p> 		<p>Removal: Remove by bending up with flat-bladed screwdrivers.</p>  <p>Radiator grille Body panel</p>
<p>CE114</p> 		
<p>CF118</p> 	 <p>Clip A Clip B (Grommet)</p>	<p>Removal: Flat-bladed screwdrivers Finisher</p>  <p>Body panel Clip A Clip B (Grommet)</p>

ALJIA0564GB

SQUEAK AND RATTLE TROUBLE DIAGNOSES

< PERIODIC MAINTENANCE >

PERIODIC MAINTENANCE

SQUEAK AND RATTLE TROUBLE DIAGNOSES

Work Flow

INFOID:000000007328499

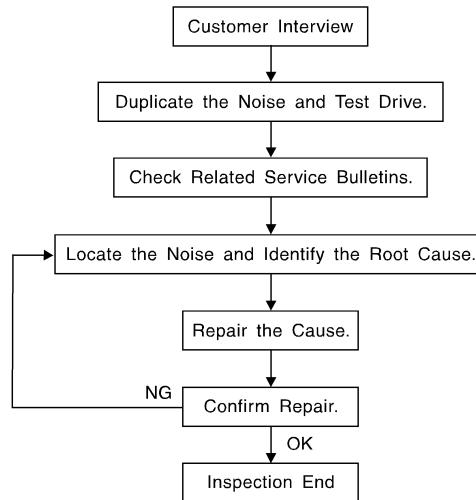

SBT842

CUSTOMER INTERVIEW

Interview the customer if possible, to determine the conditions that exist when the noise occurs. Use the Diagnostic Worksheet during the interview to document the facts and conditions when the noise occurs and any customer's comments; refer to [EXT-13, "Diagnostic Worksheet"](#). This information is necessary to duplicate the conditions that exist when the noise occurs.

- The customer may not be able to provide a detailed description or the location of the noise. Attempt to obtain all the facts and conditions that exist when the noise occurs (or does not occur).
- If there is more than one noise in the vehicle, be sure to diagnose and repair the noise that the customer is concerned about. This can be accomplished by test driving the vehicle with the customer.
- After identifying the type of noise, isolate the noise in terms of its characteristics. The noise characteristics are provided so the customer, service adviser and technician are all speaking the same language when defining the noise.
- Squeak —(Like tennis shoes on a clean floor)
Squeak characteristics include the light contact/fast movement/brought on by road conditions/hard surfaces = higher pitch noise/softer surfaces = lower pitch noises/edge to surface = chirping.
- Creak—(Like walking on an old wooden floor)
Creak characteristics include firm contact/slow movement/twisting with a rotational movement/pitch dependent on materials/often brought on by activity.
- Rattle—(Like shaking a baby rattle)
Rattle characteristics include the fast repeated contact/vibration or similar movement/loose parts/missing clip or fastener/incorrect clearance.
- Knock —(Like a knock on a door)
Knock characteristics include hollow sounding/sometimes repeating/often brought on by driver action.
- Tick—(Like a clock second hand)
Tick characteristics include gentle contacting of light materials/loose components/can be caused by driver action or road conditions.
- Thump—(Heavy, muffled knock noise)
Thump characteristics include softer knock/dead sound often brought on by activity.
- Buzz—(Like a bumble bee)
Buzz characteristics include high frequency rattle/firm contact.
- Often the degree of acceptable noise level will vary depending upon the person. A noise that you may judge as acceptable may be very irritating to the customer.
- Weather conditions, especially humidity and temperature, may have a great effect on noise level.

DUPLICATE THE NOISE AND TEST DRIVE

SQUEAK AND RATTLE TROUBLE DIAGNOSES

< PERIODIC MAINTENANCE >

If possible, drive the vehicle with the customer until the noise is duplicated. Note any additional information on the Diagnostic Worksheet regarding the conditions or location of the noise. This information can be used to duplicate the same conditions when you confirm the repair.

If the noise can be duplicated easily during the test drive, to help identify the source of the noise, try to duplicate the noise with the vehicle stopped by doing one or all of the following:

- 1) Close a door.
 - 2) Tap or push/pull around the area where the noise appears to be coming from.
 - 3) Rev the engine.
 - 4) Use a floor jack to recreate vehicle "twist".
 - 5) At idle, apply engine load (electrical load, half-clutch on M/T model, drive position on CVT and A/T models).
 - 6) Raise the vehicle on a hoist and hit a tire with a rubber hammer.
- Drive the vehicle and attempt to duplicate the conditions the customer states exist when the noise occurs.
 - If it is difficult to duplicate the noise, drive the vehicle slowly on an undulating or rough road to stress the vehicle body.

CHECK RELATED SERVICE BULLETINS

After verifying the customer concern or symptom, check ASIST for Technical Service Bulletins (TSBs) related to that concern or symptom.

If a TSB relates to the symptom, follow the procedure to repair the noise.

LOCATE THE NOISE AND IDENTIFY THE ROOT CAUSE

1. Narrow down the noise to a general area. To help pinpoint the source of the noise, use a listening tool (Chassis Ear: J-39570, Engine Ear: J-39565 and mechanic's stethoscope).
2. Narrow down the noise to a more specific area and identify the cause of the noise by:
 - removing the components in the area that you suspect the noise is coming from.
Do not use too much force when removing clips and fasteners, otherwise clips and fasteners can be broken or lost during the repair, resulting in the creation of new noise.
 - tapping or pushing/pulling the component that you suspect is causing the noise.
Do not tap or push/pull the component with excessive force, otherwise the noise will be eliminated only temporarily.
 - feeling for a vibration with your hand by touching the component(s) that you suspect is (are) causing the noise.
 - placing a piece of paper between components that you suspect are causing the noise.
 - looking for loose components and contact marks.Refer to [EXT-11, "Generic Squeak and Rattle Troubleshooting"](#).

REPAIR THE CAUSE

- If the cause is a loose component, tighten the component securely.
- If the cause is insufficient clearance between components:
 - separate components by repositioning or loosening and retightening the component, if possible.
 - insulate components with a suitable insulator such as urethane pads, foam blocks, felt cloth tape or urethane tape. A NISSAN Squeak and Rattle Kit (J-43980) is available through your authorized NISSAN Parts Department.

CAUTION:

Do not use excessive force as many components are constructed of plastic and may be damaged.

Always check with the Parts Department for the latest parts information.

The following materials are contained in the NISSAN Squeak and Rattle Kit (J-43980). Each item can be ordered separately as needed.

URETHANE PADS [1.5 mm (0.059 in) thick]

Insulates connectors, harness, etc.

76268-9E005: 100×135 mm (3.94×5.31 in)/76884-71L01: 60×85 mm (2.36×3.35 in)/76884-71L02: 15×25 mm (0.59×0.98 in)

INSULATOR (Foam blocks)

Insulates components from contact. Can be used to fill space behind a panel.

73982-9E000: 45 mm (1.77 in) thick, 50×50 mm (1.97×1.97 in)/73982-50Y00: 10 mm (0.39 in) thick, 50×50 mm (1.97×1.97 in)

INSULATOR (Light foam block)

80845-71L00: 30 mm (1.18 in) thick, 30×50 mm (1.18×1.97 in)

FELT CLOTH TAPE

Used to insulate where movement does not occur. Ideal for instrument panel applications.

68370-4B000: 15×25 mm (0.59×0.98 in) pad/68239-13E00: 5 mm (0.20 in) wide tape roll. The following materials not found in the kit can also be used to repair squeaks and rattles.

SQUEAK AND RATTLE TROUBLE DIAGNOSES

< PERIODIC MAINTENANCE >

UHMW (TEFLON) TAPE

Insulates where slight movement is present. Ideal for instrument panel applications.

SILICONE GREASE

Used instead of UHMW tape that will be visible or not fit.

Note: Will only last a few months.

SILICONE SPRAY

Use when grease cannot be applied.

DUCT TAPE

Use to eliminate movement.

CONFIRM THE REPAIR

Confirm that the cause of a noise is repaired by test driving the vehicle. Operate the vehicle under the same conditions as when the noise originally occurred. Refer to the notes on the Diagnostic Worksheet.

Generic Squeak and Rattle Troubleshooting

INFOID:000000007328500

Refer to Table of Contents for specific component removal and installation information.

INSTRUMENT PANEL

Most incidents are caused by contact and movement between:

1. The cluster lid A and instrument panel
2. Acrylic lens and combination meter housing
3. Instrument panel to front pillar garnish
4. Instrument panel to windshield
5. Instrument panel pins
6. Wiring harnesses behind the combination meter
7. A/C defroster duct and duct joint

These incidents can usually be located by tapping or moving the components to duplicate the noise or by pressing on the components while driving to stop the noise. Most of these incidents can be repaired by applying felt cloth tape or silicone spray (in hard to reach areas). Urethane pads can be used to insulate wiring harness.

CAUTION:

Do not use silicone spray to isolate a squeak or rattle. If you saturate the area with silicone, you will not be able to recheck the repair.

CENTER CONSOLE

Components to pay attention to include:

1. Shift selector assembly cover to finisher
2. A/C control unit and cluster lid C
3. Wiring harnesses behind audio and A/C control unit

The instrument panel repair and isolation procedures also apply to the center console.

DOORS

Pay attention to the:

1. Finisher and inner panel making a slapping noise
2. Inside handle escutcheon to door finisher
3. Wiring harnesses tapping
4. Door striker out of alignment causing a popping noise on starts and stops

Tapping or moving the components or pressing on them while driving to duplicate the conditions can isolate many of these incidents. You can usually insulate the areas with felt cloth tape or insulator foam blocks from the NISSAN Squeak and Rattle Kit (J-43980) to repair the noise.

TRUNK

Trunk noises are often caused by a loose jack or loose items put into the trunk by the owner.

In addition look for:

1. Trunk lid bumpers out of adjustment
2. Trunk lid striker out of adjustment
3. The trunk lid torsion bars knocking together

A
B
C
D
E
F
G
H
I
J
EXT
L
M
N
O
P

SQUEAK AND RATTLE TROUBLE DIAGNOSES

< PERIODIC MAINTENANCE >

4. A loose license plate or bracket

Most of these incidents can be repaired by adjusting, securing or insulating the item(s) or component(s) causing the noise.

SUNROOF/HEADLINING

Noises in the sunroof/headlining area can often be traced to one of the following:

1. Sunroof lid, rail, linkage or seals making a rattle or light knocking noise
2. Sun visor shaft shaking in the holder
3. Front or rear windshield touching headliner and squeaking

Again, pressing on the components to stop the noise while duplicating the conditions can isolate most of these incidents. Repairs usually consist of insulating with felt cloth tape.

OVERHEAD CONSOLE (FRONT AND REAR)

Overhead console noises are often caused by the console panel clips not being engaged correctly. Most of these incidents are repaired by pushing up on the console at the clip locations until the clips engage.

In addition look for:

1. Loose harness or harness connectors.
2. Front console map/reading lamp lens loose.
3. Loose screws at console attachment points.

SEATS

When isolating seat noise it's important to note the position the seat is in and the load placed on the seat when the noise is present. These conditions should be duplicated when verifying and isolating the cause of the noise.

Cause of seat noise include:

1. Headrest rods and holder
2. A squeak between the seat pad cushion and frame
3. The rear seatback lock and bracket

These noises can be isolated by moving or pressing on the suspected components while duplicating the conditions under which the noise occurs. Most of these incidents can be repaired by repositioning the component or applying urethane tape to the contact area.

UNDERHOOD

Some interior noise may be caused by components under the hood or on the engine wall. The noise is then transmitted into the passenger compartment.

Causes of transmitted underhood noise include:

1. Any component installed to the engine wall
2. Components that pass through the engine wall
3. Engine wall mounts and connectors
4. Loose radiator installation pins
5. Hood bumpers out of adjustment
6. Hood striker out of adjustment

These noises can be difficult to isolate since they cannot be reached from the interior of the vehicle. The best method is to secure, move or insulate one component at a time and test drive the vehicle. Also, engine RPM or load can be changed to isolate the noise. Repairs can usually be made by moving, adjusting, securing, or insulating the component causing the noise.

SQUEAK AND RATTLE TROUBLE DIAGNOSES

< PERIODIC MAINTENANCE >

Diagnostic Worksheet

INFOID:000000007328501

Dear Customer:

We are concerned about your satisfaction with your vehicle. Repairing a squeak or rattle sometimes can be very difficult. To help us fix your vehicle right the first time, please take a moment to note the area of the vehicle where the squeak or rattle occurs and under what conditions. You may be asked to take a test drive with a service advisor or technician to ensure we confirm the noise you are hearing.

SQUEAK & RATTLE DIAGNOSTIC WORKSHEET

I. WHERE DOES THE NOISE COME FROM? (circle the area of the vehicle)

The illustrations are for reference only, and may not reflect the actual configuration of your vehicle.

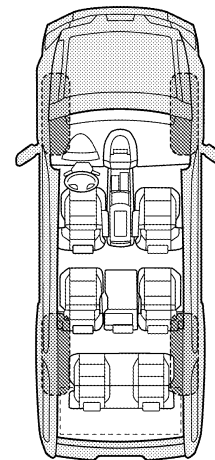
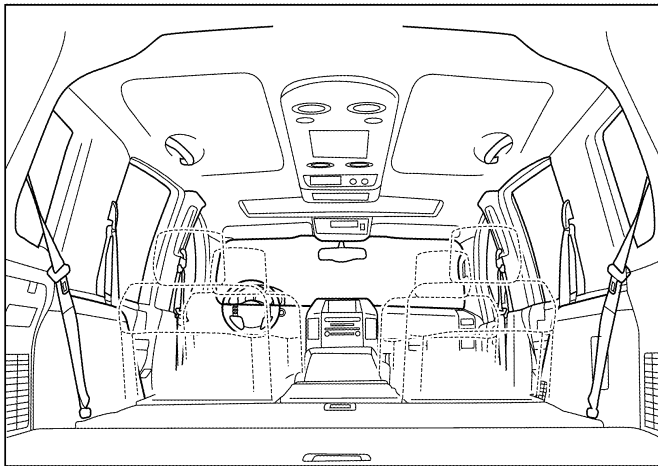
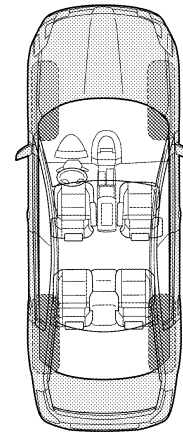
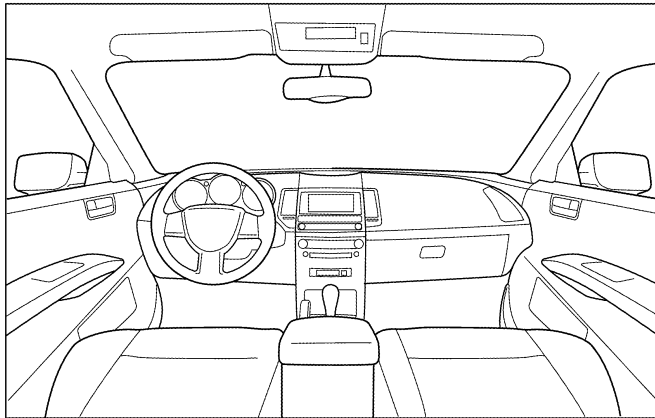

Continue to page 2 of the worksheet and briefly describe the location of the noise or rattle. In addition, please indicate the conditions which are present when the noise occurs.

A
B
C
D
E
F
G
H
I
J
EXT
L
M
N
O
P

SQUEAK AND RATTLE TROUBLE DIAGNOSES

< PERIODIC MAINTENANCE >

SQUEAK & RATTLE DIAGNOSTIC WORKSHEET - page 2

Briefly describe the location where the noise occurs:

II. WHEN DOES IT OCCUR? (please check the boxes that apply)

- | | |
|---|--|
| <input type="checkbox"/> Anytime | <input type="checkbox"/> After sitting out in the rain |
| <input type="checkbox"/> 1st time in the morning | <input type="checkbox"/> When it is raining or wet |
| <input type="checkbox"/> Only when it is cold outside | <input type="checkbox"/> Dry or dusty conditions |
| <input type="checkbox"/> Only when it is hot outside | <input type="checkbox"/> Other: |

III. WHEN DRIVING:

- Through driveways
- Over rough roads
- Over speed bumps
- Only about ____ mph
- On acceleration
- Coming to a stop
- On turns: left, right or either (circle)
- With passengers or cargo
- Other: _____
- After driving ____ miles or ____ minutes

IV. WHAT TYPE OF NOISE

- Squeak (like tennis shoes on a clean floor)
- Creak (like walking on an old wooden floor)
- Rattle (like shaking a baby rattle)
- Knock (like a knock at the door)
- Tick (like a clock second hand)
- Thump (heavy muffled knock noise)
- Buzz (like a bumble bee)

TO BE COMPLETED BY DEALERSHIP PERSONNEL

Test Drive Notes:

	YES	NO	Initials of person performing
Vehicle test driven with customer	<input type="checkbox"/>	<input type="checkbox"/>	_____
- Noise verified on test drive	<input type="checkbox"/>	<input type="checkbox"/>	_____
- Noise source located and repaired	<input type="checkbox"/>	<input type="checkbox"/>	_____
- Follow up test drive performed to confirm repair	<input type="checkbox"/>	<input type="checkbox"/>	_____

VIN: _____ Customer Name _____

W.O.# _____ Date: _____

This form must be attached to Work Order

LATA0071E

FRONT BUMPER

< REMOVAL AND INSTALLATION >

REMOVAL AND INSTALLATION

FRONT BUMPER

Removal and Installation

INFOID:000000007328503

STEEL BUMPER

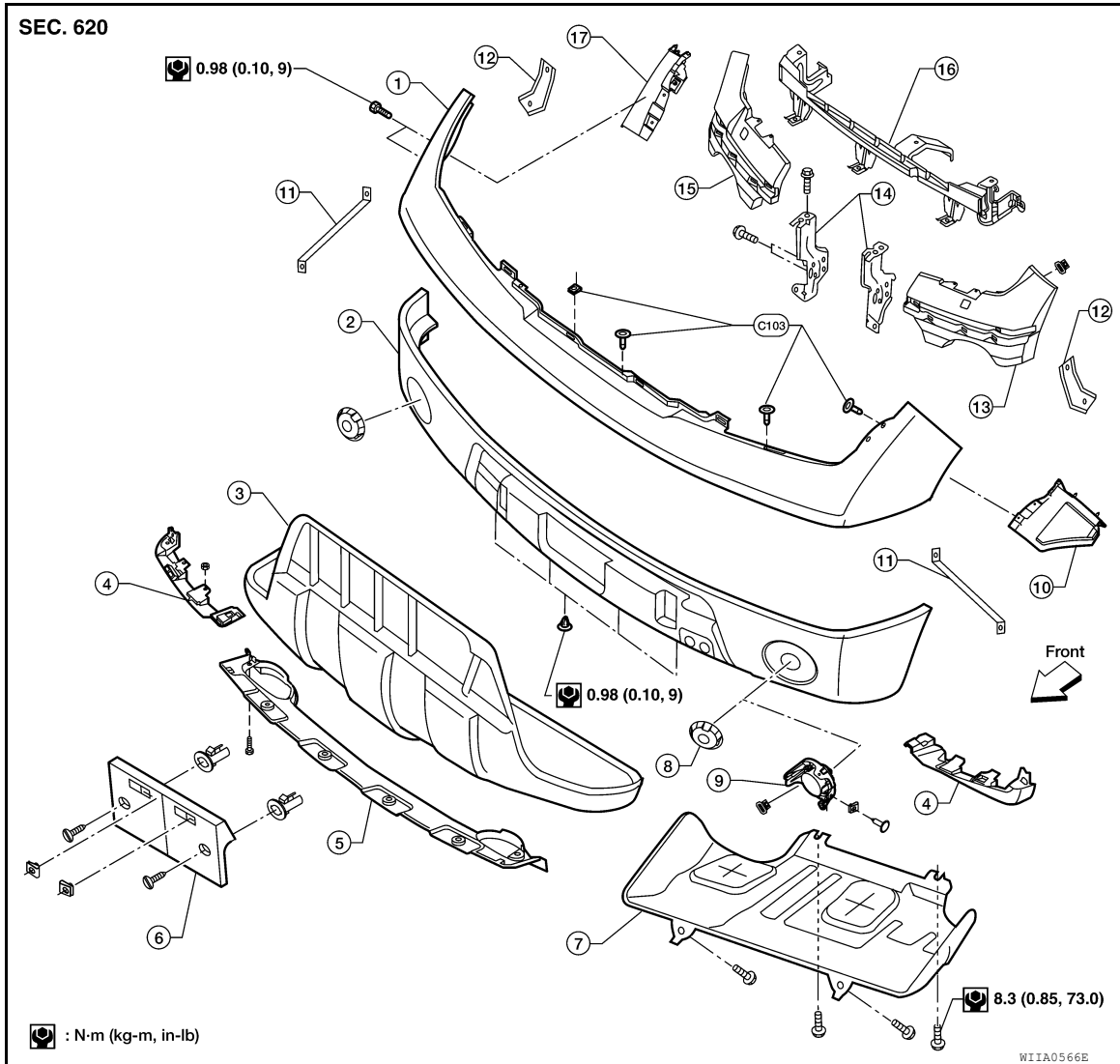

- | | | |
|-----------------------------------|--|---|
| 1. Front bumper upper valance | 2. Front bumper assembly | 3. Front bumper lower valance |
| 4. Front valance RH/LH | 5. Front valance center | 6. Front license plate bracket |
| 7. Engine under cover | 8. Fog lamp opening finisher (if equipped) | 9. Fog lamp (if equipped) |
| 10. Front bumper stay LH | 11. Front bumper side brace | 12. Front bumper reinforcement stay RH/LH |
| 13. Front bumper reinforcement LH | 14. Front bumper bracket RH/LH | 15. Front bumper reinforcement RH |
| 16. Front bumper bracket center | 17. Front bumper stay RH | |

Removal

1. Remove front grille. Refer to [EXT-23, "Removal and Installation"](#).
2. Remove front valance LH, center, then RH.
3. Disconnect front valance lower from engine under cover.
4. Remove front bumper stays LH and RH.
5. Disconnect fog lamp harnesses, (if equipped).

FRONT BUMPER

< REMOVAL AND INSTALLATION >

6. Remove front bumper reinforcement stays RH and LH.
7. Disconnect front fender protector and front bumper upper valance from fender.
8. Disconnect front bumper upper valance from front bumper bracket center.
9. Remove front bumper assembly.

Installation

Installation is in the reverse order of removal.

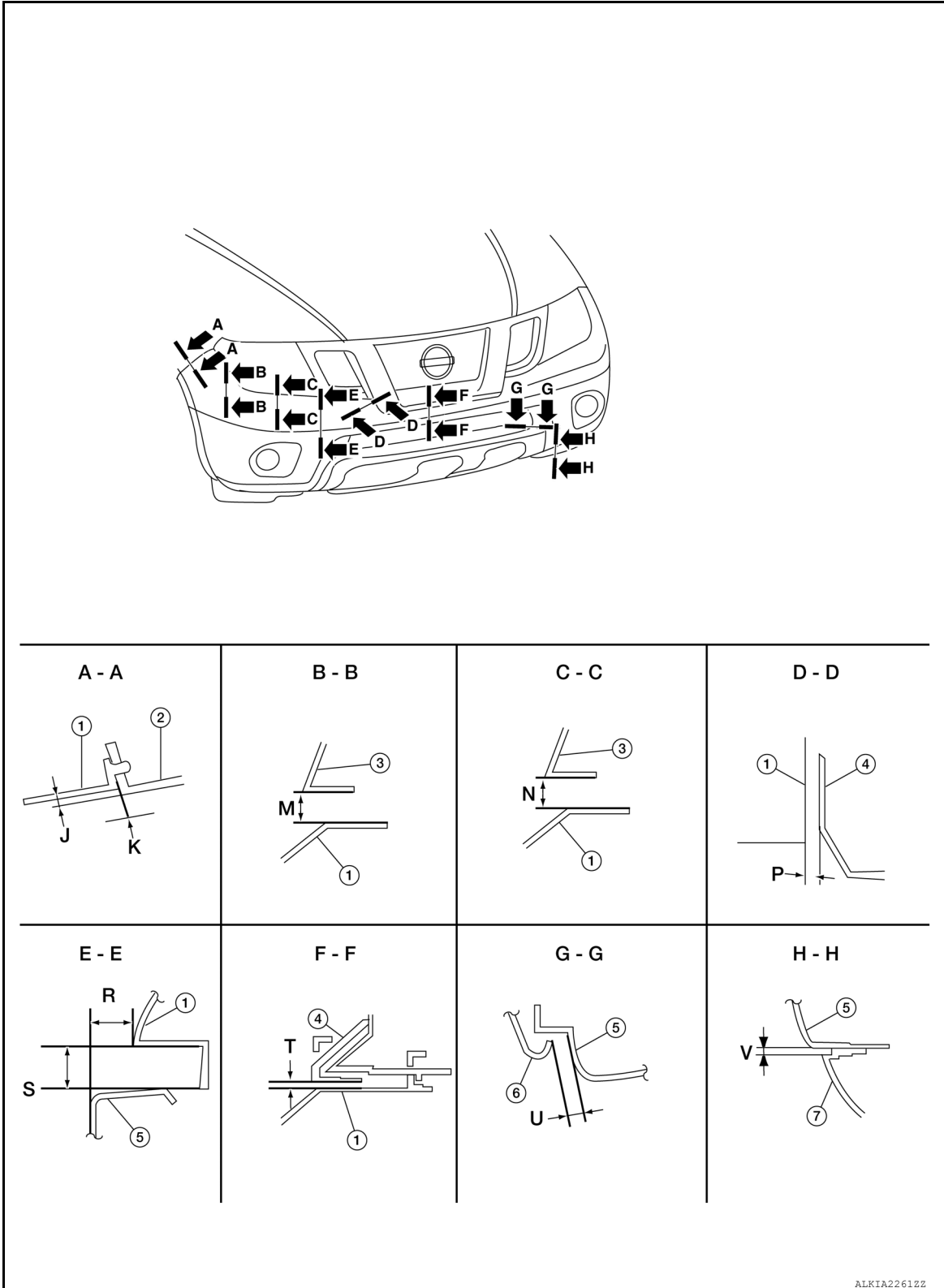

ALKIA2261ZZ

FRONT BUMPER

< REMOVAL AND INSTALLATION >

- | | | |
|-------------------------------|--------------------------|-------------------------------|
| 1. Front bumper upper valance | 2. Front fender | 3. Head lamp assembly |
| 4. Front grille | 5. Front bumper assembly | 6. Front bumper lower valance |
| 7. Front valance center | | |

Units: mm (in)

Portion	Measurement	Standard	Difference (MAX)
A-A	J	Surface height	0.0 (0.000)
	K	Clearance	0.8 (0.031)
B-B	M	Clearance	3.0 (0.118)
C-C	N	Clearance	3.0 (0.118)
D-D	P	Clearance	3.0 (0.118)
E-E	S	Clearance	14.0 (0.551)
	R	Surface height	3.0 (0.0118)
F-F	T	Clearance	3.0 (0.118)
G-G	U	Clearance	2.0 (0.079)
H-H	V	Clearance	2.0 (0.079)

PLASTIC BUMPER

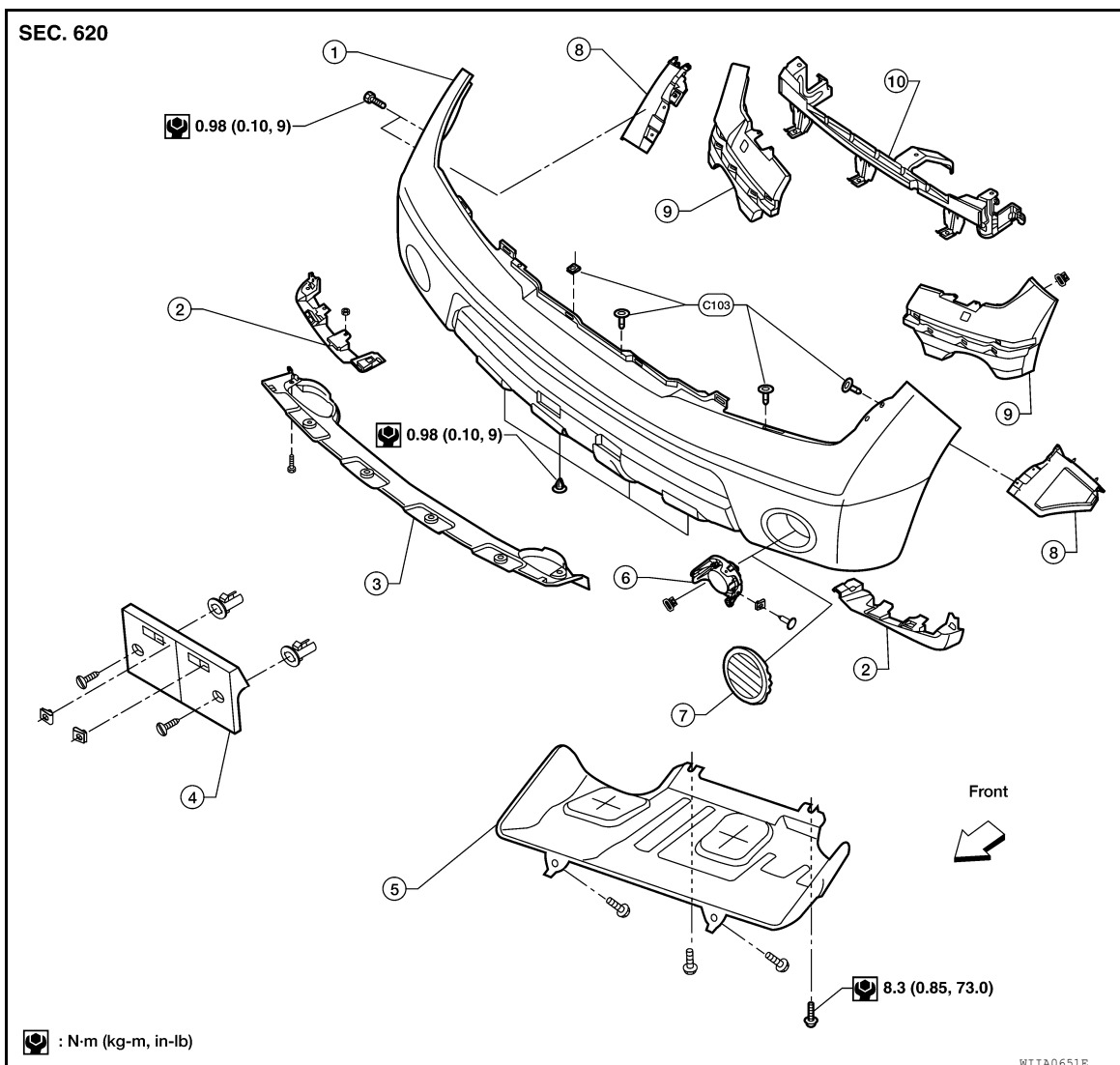

FRONT BUMPER

< REMOVAL AND INSTALLATION >

- | | | |
|--|-------------------------------|-------------------------------------|
| 1. Front bumper assembly | 2. Front valance RH/LH | 3. Front valance center |
| 4. Front license plate bracket | 5. Engine under cover | 6. Fog lamp (if equipped) |
| 7. Fog lamp opening finisher (if equipped) | 8. Front bumper bracket RH/LH | 9. Front bumper reinforcement RH/LH |
| 10. Front bumper bracket center | | |

Removal

1. Remove front grille. Refer to [EXT-23, "Removal and Installation"](#).
2. Remove front valance LH, center, then RH.
3. Disconnect front portion of front fender protectors LH and RH. Refer to [EXT-27, "Removal and Installation of Front Fender Protector"](#).
4. Disconnect front bumper bracket center and front fenders.
5. Disconnect fog lamp harnesses (if equipped).
6. Remove front bumper assembly.

Installation

Installation is in the reverse order of removal.

FRONT BUMPER

< REMOVAL AND INSTALLATION >

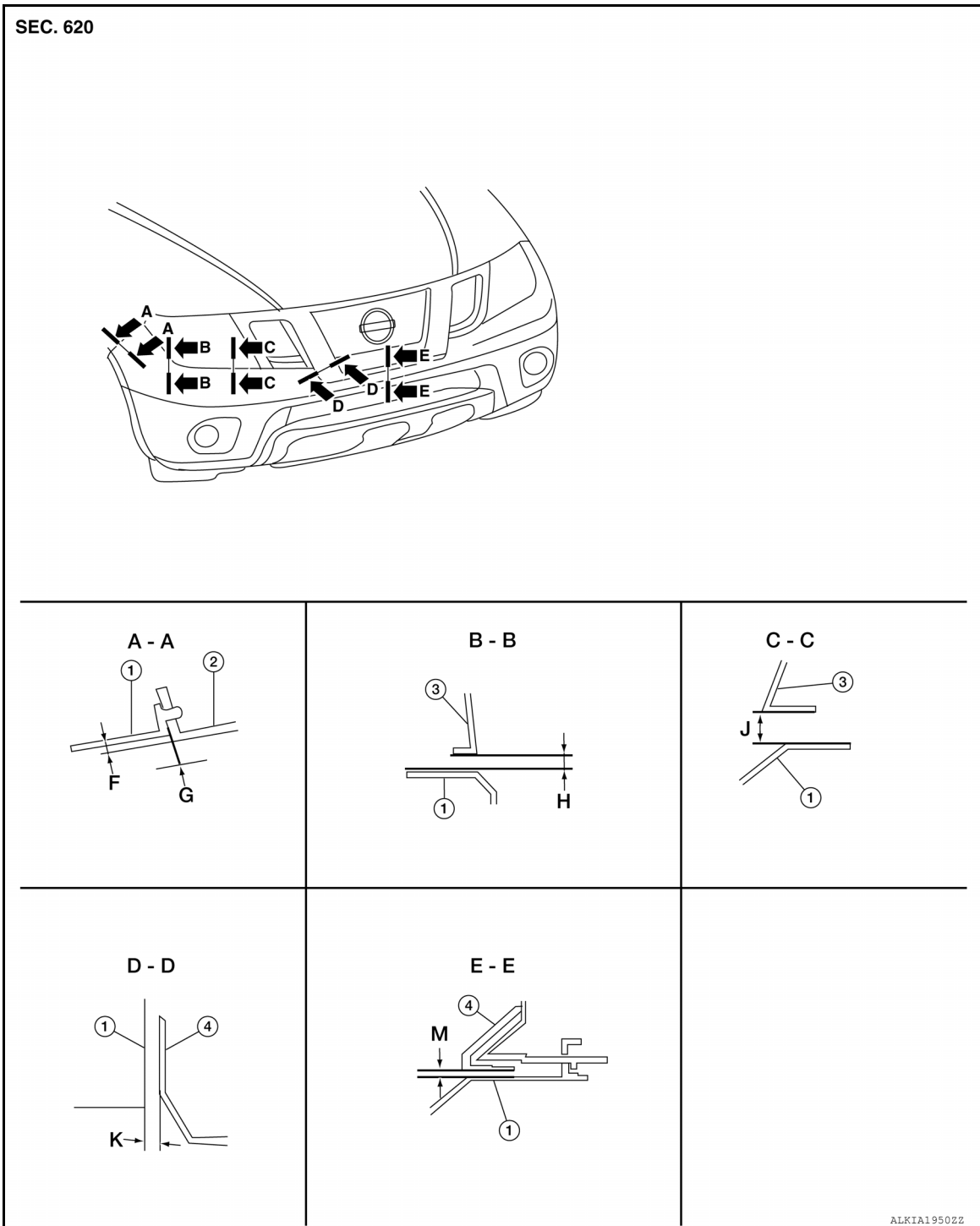

- 1. Front bumper assembly
- 2. Front fender
- 3. Head lamp assembly
- 4. Front grille

Units: mm (in)

Portion	Measurement	Standard	Difference (MAX)
A-A	F Clearance	0.0 (0.000)	± 0.7 (0.028)
	G Surface height	0.8 (0.031)	± 1.0 (0.039)
B-B	H Clearance	3.0 (0.118)	± 1.5 (0.059)
C-C	J Clearance	3.0 (0.118)	± 1.5 (0.059)

FRONT BUMPER

< REMOVAL AND INSTALLATION >

D-D	K	Clearance	3.0 (0.118)	± 1.5 (0.059)
E-E	M	Clearance	3.0 (0.118)	± 1.5 (0.059)

REAR BUMPER

< REMOVAL AND INSTALLATION >

REAR BUMPER

Removal and Installation

INFOID:000000007328504

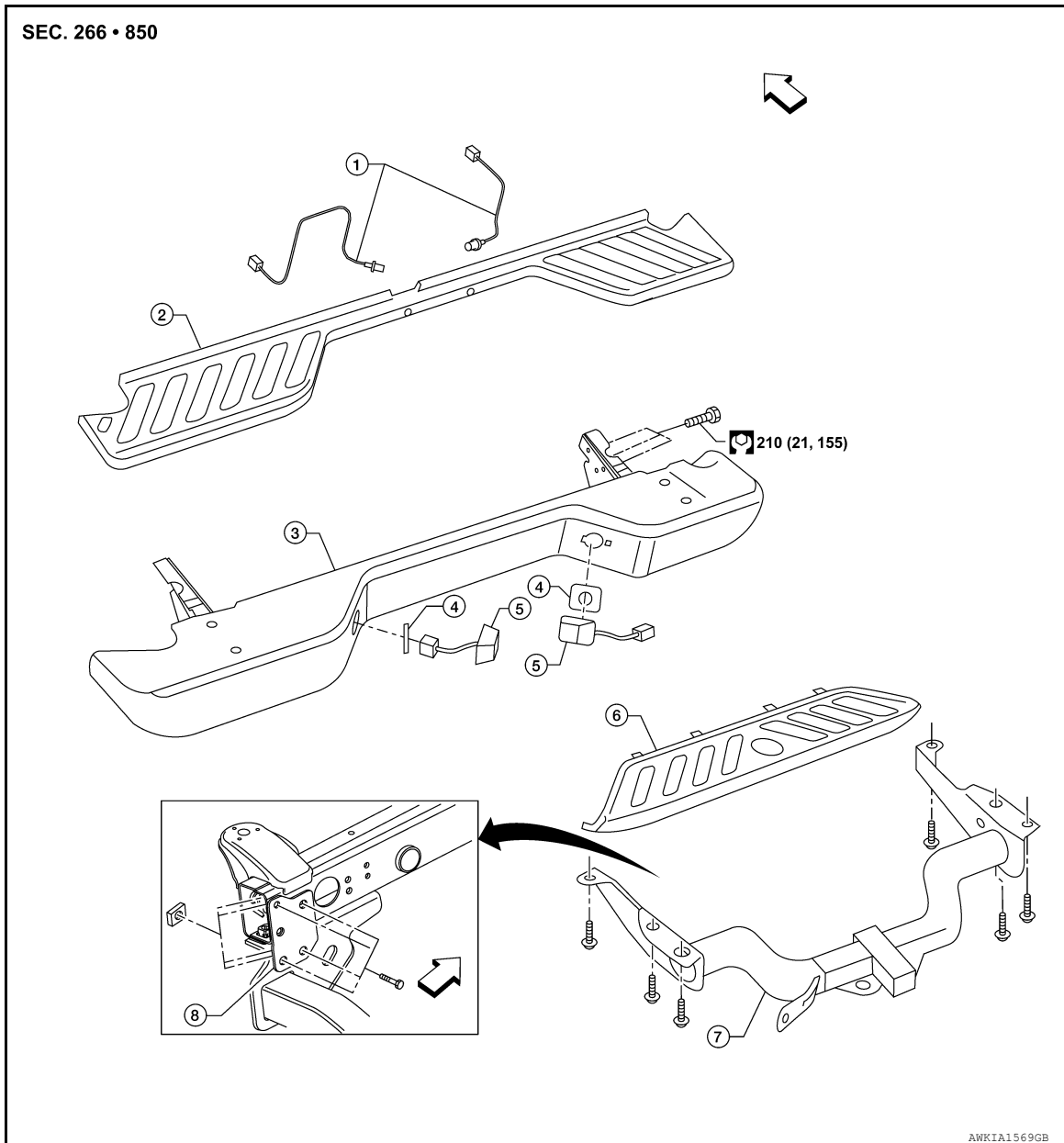

- | | | |
|-------------------------------|--|-------------------|
| 1. License lamp harness RH/LH | 2. Upper step pad | 3. Rear bumper |
| 4. License lamp gasket | 5. License lamp RH/LH | 6. Lower step pad |
| 7. Tow hitch (if equipped) | 8. Tow hitch reinforcement (if equipped) | ↔ Vehicle front |

REMOVAL

NOTE:

It is not necessary to remove the tow hitch (if equipped) to service the rear bumper.

1. Remove upper and lower step pads.
2. Disconnect license lamp harness RH/LH.
3. Release clips from license lamp RH/LH, then remove lamps from rear bumper.
4. Remove rear bumper.
5. Remove rear bumper reinforcement from frame.

A
B
C
D
E
F
G
H
I
J
EXT
L
M
N
O
P

REAR BUMPER

< REMOVAL AND INSTALLATION >

6. Remove tow hitch (if equipped).

INSTALLATION

Installation is in the reverse order of removal.

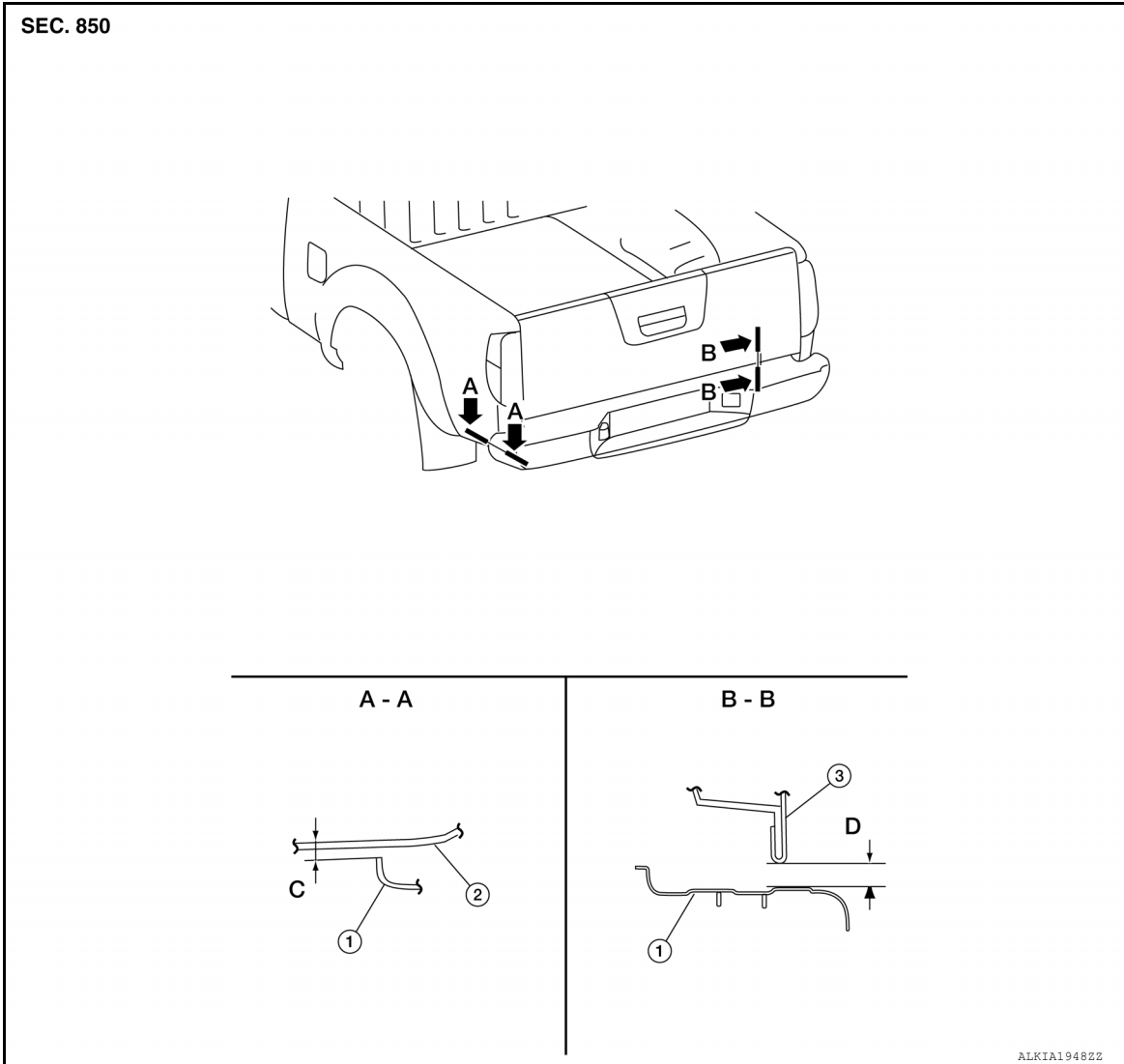

1. Rear bumper

2. Bed side outer LH

3. Tail gate

Units: mm (in)

Portion	Measurement		Standard	Difference (MAX)
A-A	C	Clearance	20.0 (0.787)	± 5.0 (0.197)
B-B	D	Clearance	37.2 (1.465)	± 6.0 (0.236)

FRONT GRILLE

< REMOVAL AND INSTALLATION >

FRONT GRILLE

Removal and Installation

INFOID:000000007328505

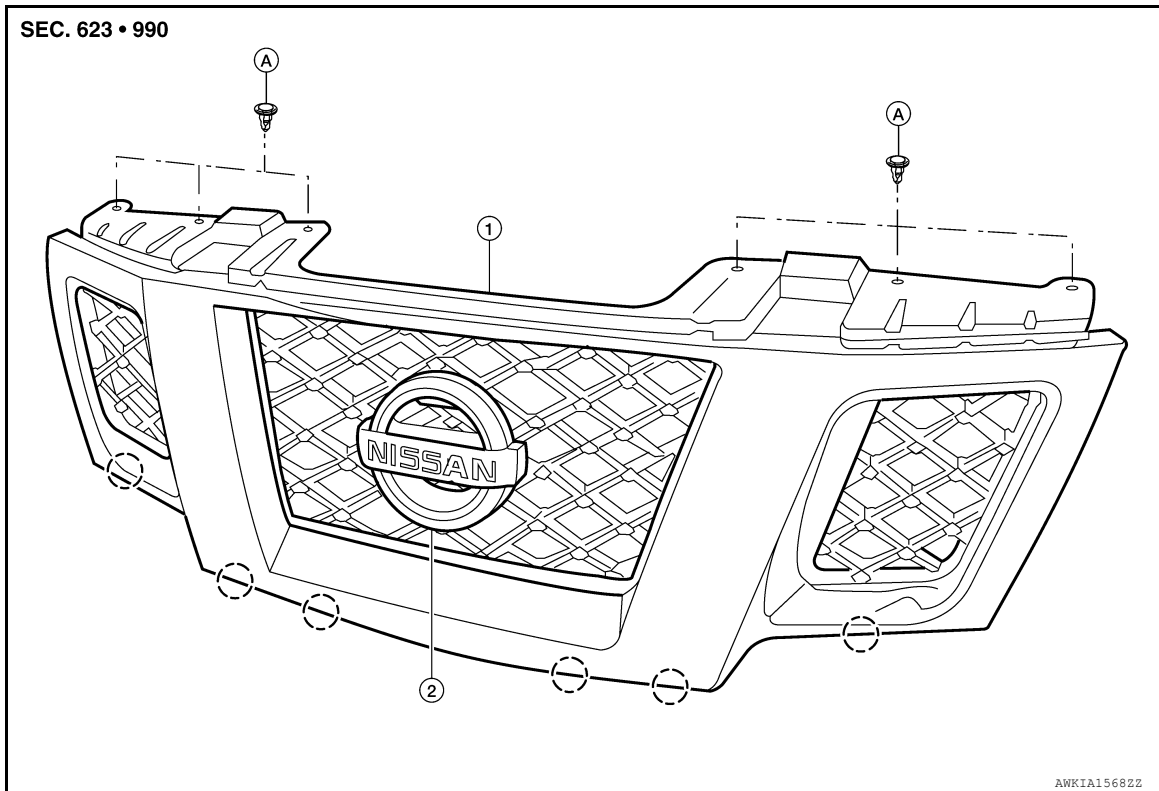

1. Front grille

2. Front emblem

A. Clips C205

○ Pawl

REMOVAL

1. Release the upper clips from the front grille.
2. Release the front grille pawls and remove the front grille from member.
3. Remove the front grille emblem, if necessary.

INSTALLATION

Installation is in the reverse order of removal.

A
B
C
D
E
F
G
H
I
J
L
M
N
O
P

EXT

COWL TOP

< REMOVAL AND INSTALLATION >

COWL TOP

Removal and Installation

INFOID:000000007328506

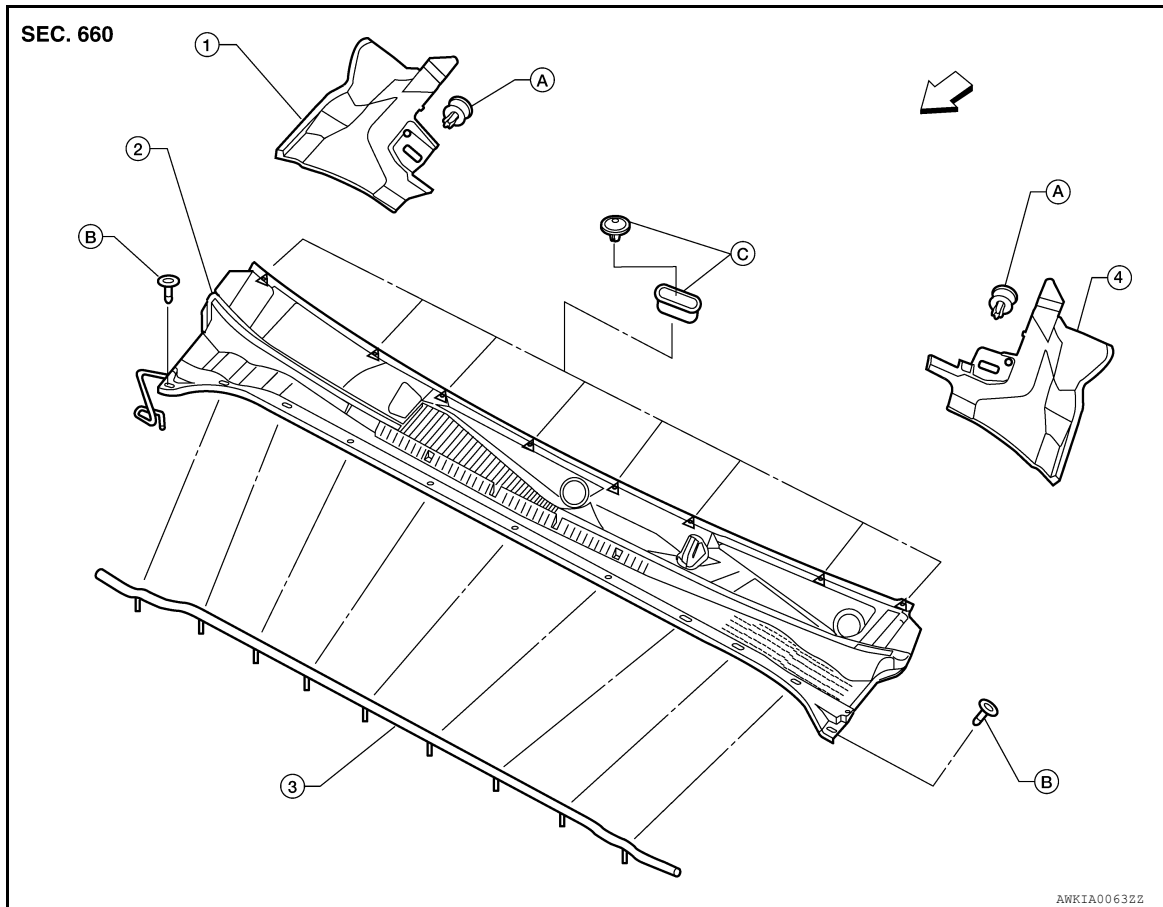

- | | | |
|--------------------------|-----------------|------------------|
| 1. Cowl top extension RH | 2. Cowl top | 3. Cowl top seal |
| 4. Cowl top extension LH | A. Clip C205 | B. Clip C103 |
| C. Grommet CF110 | ← Vehicle front | |

REMOVAL

1. Remove the front wiper arms. Refer to [WW-54, "Front Wiper Arms"](#).
2. Remove the rubber seal and audio antenna rod. Refer to [AV-34, "Removal and Installation"](#).
3. Remove the cowl top seal.
4. Remove the cowl top clips and lift the cowl top, disconnect the washer tubes from the washer nozzles and remove the cowl top.
5. Release the clips and remove the LH and RH cowl top extensions.

INSTALLATION

Installation is in the reverse order of removal.

FRONT FENDER

< REMOVAL AND INSTALLATION >

FRONT FENDER

Removal and Installation

INFOID:000000007328507

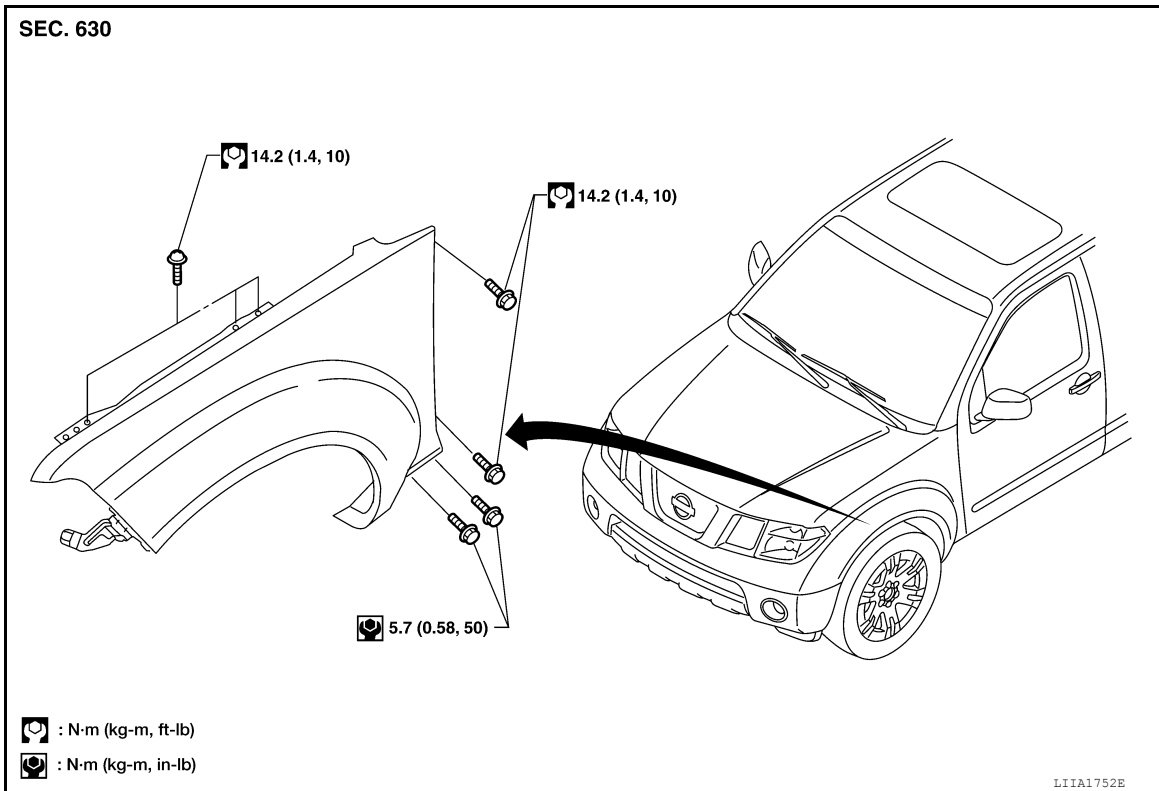

REMOVAL

1. Remove headlamp assembly. Refer to [EXL-139, "Removal and Installation"](#).
2. Remove front fender protector. Refer to [EXT-27, "Removal and Installation of Front Fender Protector"](#).
3. Remove front bumper. Refer to [EXT-15, "Removal and Installation"](#).
4. Remove hood prop rod and hood prop rod hold down clip.
5. Remove front fender bolts from hoodledge and dash panel.
6. Remove front fender bolts from rocker panel and radiator core support member.
7. Remove front fender.

INSTALLATION

Installation is in the reverse order of removal.

A
B
C
D
E
F
G
H
I
J
L
M
N
O
P

EXT

FENDER PROTECTOR

< REMOVAL AND INSTALLATION >

FENDER PROTECTOR

Component

INFOID:000000007328508

Front - Steel Bumper

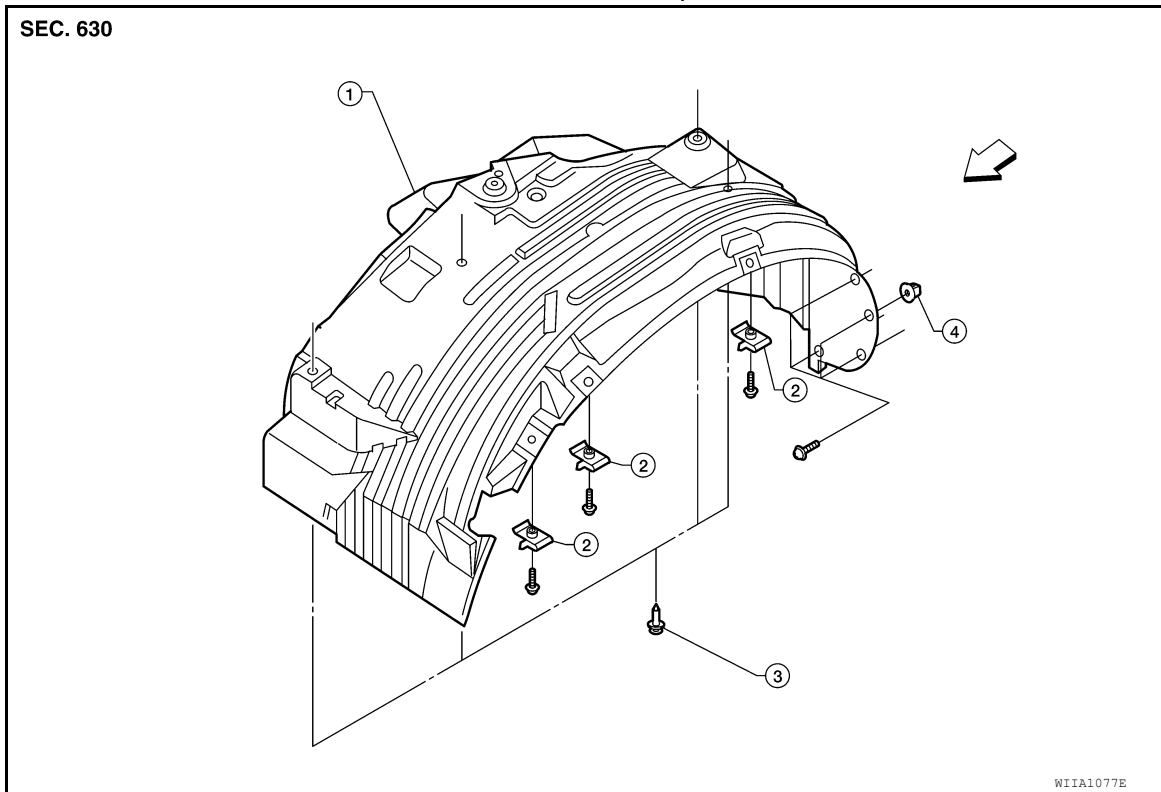

1. Fender protector LH

2. Nuts

3. Screw

4. Grommet

← Vehicle front

FENDER PROTECTOR

< REMOVAL AND INSTALLATION >

Front - Plastic Bumper

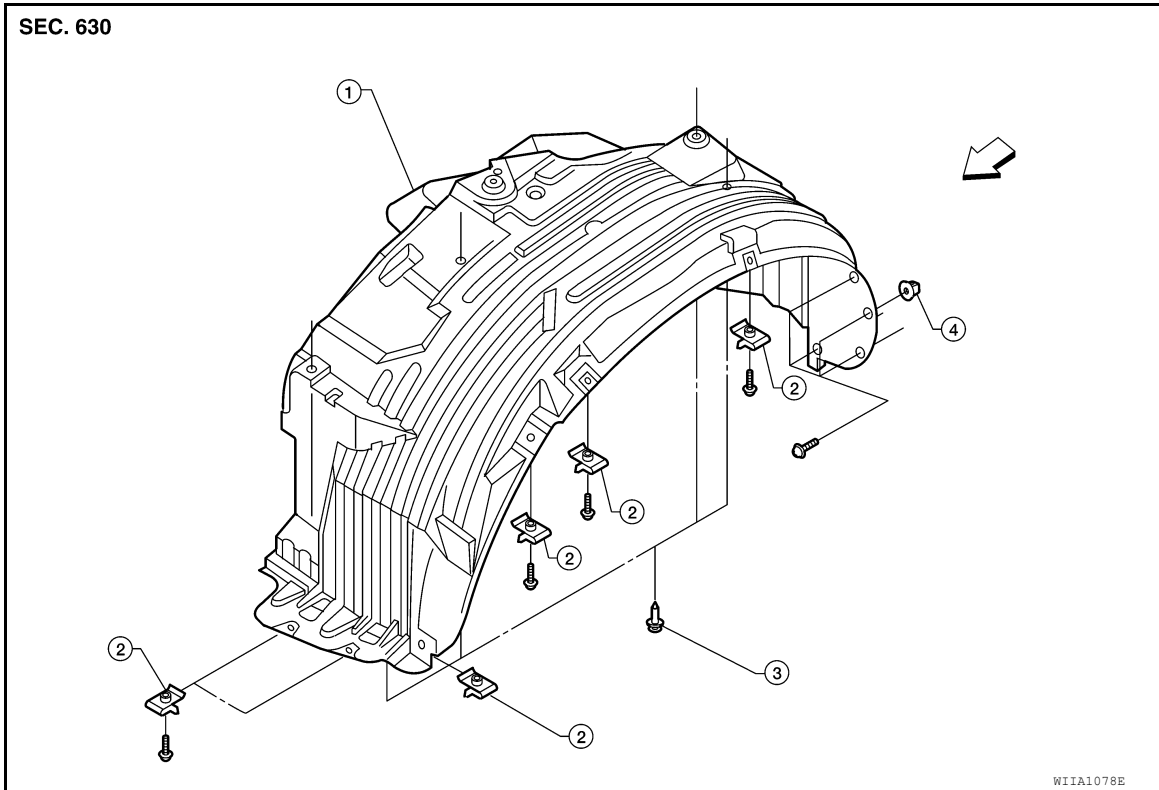

- 1. Fender protector LH
- 4. Grommet

- 2. Nut
- ← Vehicle front

- 3. Screw

Rear

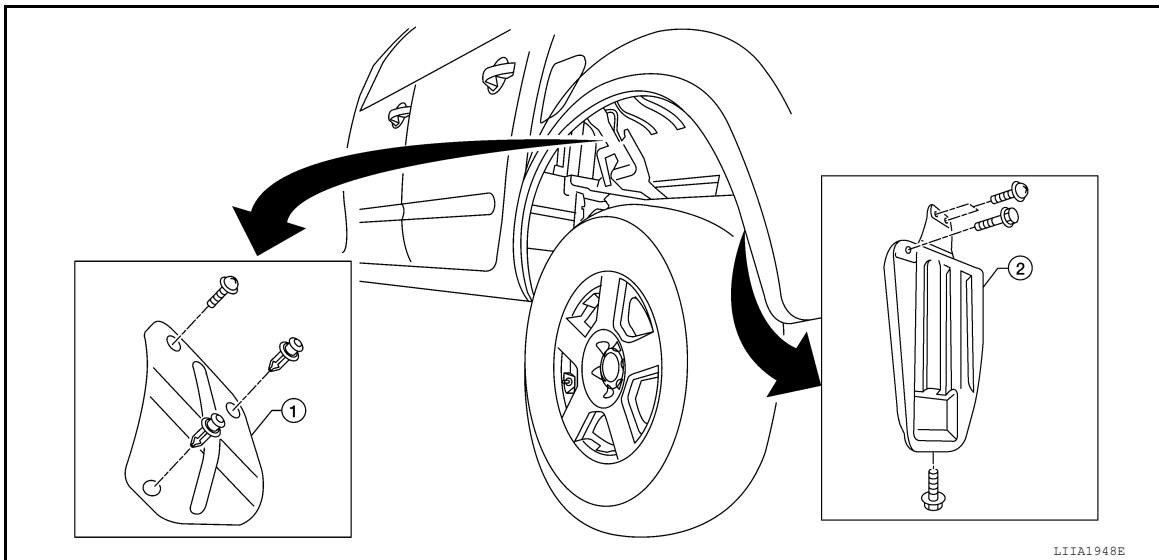

- 1. Fuel filler pipe shield

- 2. Rear fender shield

Removal and Installation of Front Fender Protector

INFOID:000000007328509

REMOVAL

1. Remove mudguard. Refer to [EXT-29. "Removal and Installation"](#).
2. Remove screws.
3. Remove plastic clips.
4. Remove grommets.

A
B
C
D
E
F
G
H
I
J
EXT
L
M
N
O
P

FENDER PROTECTOR

< REMOVAL AND INSTALLATION >

5. Remove front fender protector.

INSTALLATION

Installation is in the reverse order of removal.

Removal and Installation of Rear Fender Protector

INFOID:000000007328510

REMOVAL

1. Remove screws.
2. Remove pushpin.
3. Remove fuel filler pipe shield or rear fender shield.

INSTALLATION

Installation is in the reverse order of removal.

MUDGUARD

< REMOVAL AND INSTALLATION >

MUDGUARD

Removal and Installation

INFOID:000000007328511

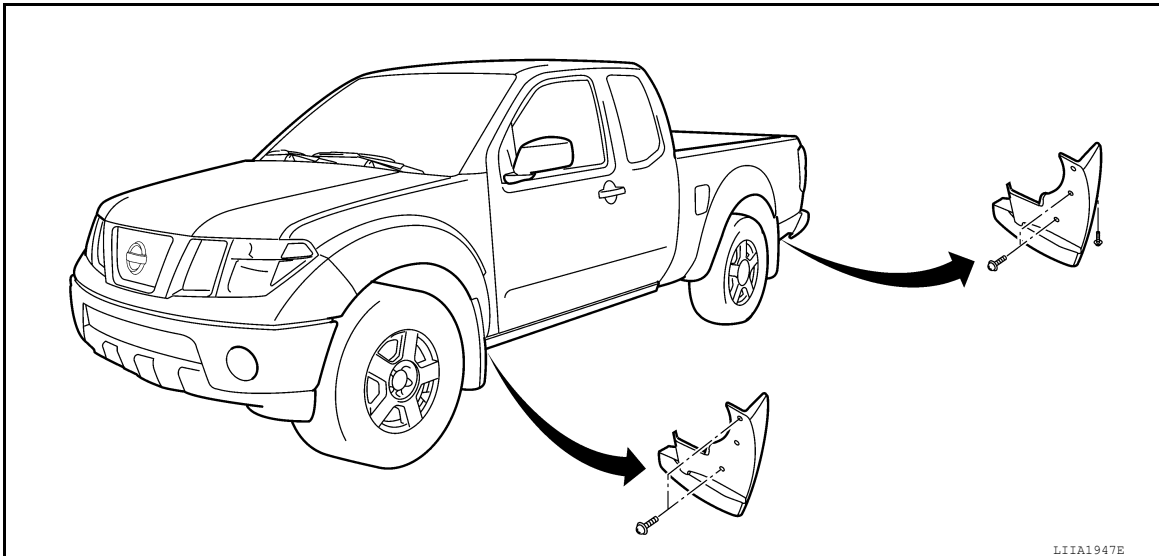

NOTE:

King Cab shown Crew Cab similar.

REMOVAL

1. Remove the mudguard fasteners.
2. Remove the mudguard.

INSTALLATION

Installation is in the reverse order of removal.

A
B
C
D
E
F
G
H
I
J
L
M
N
O
P

EXT

RUNNING BOARDS

< REMOVAL AND INSTALLATION >

RUNNING BOARDS

Removal and Installation

INFOID:000000007328512

SEC. 767

KING CAB

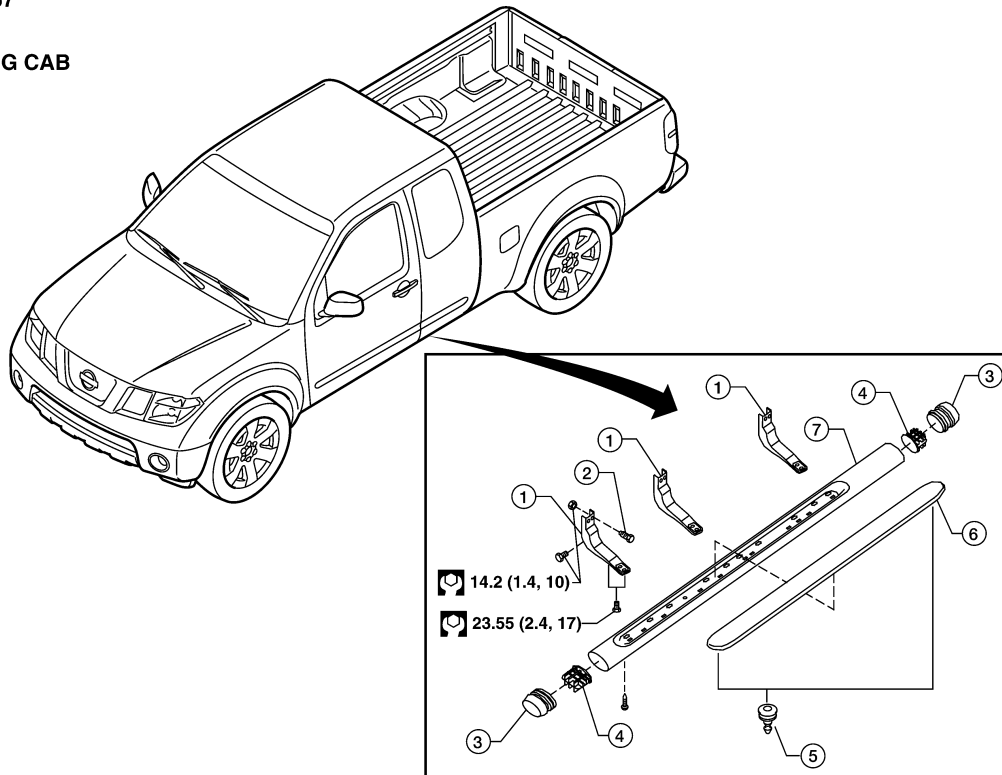

CREW CAB

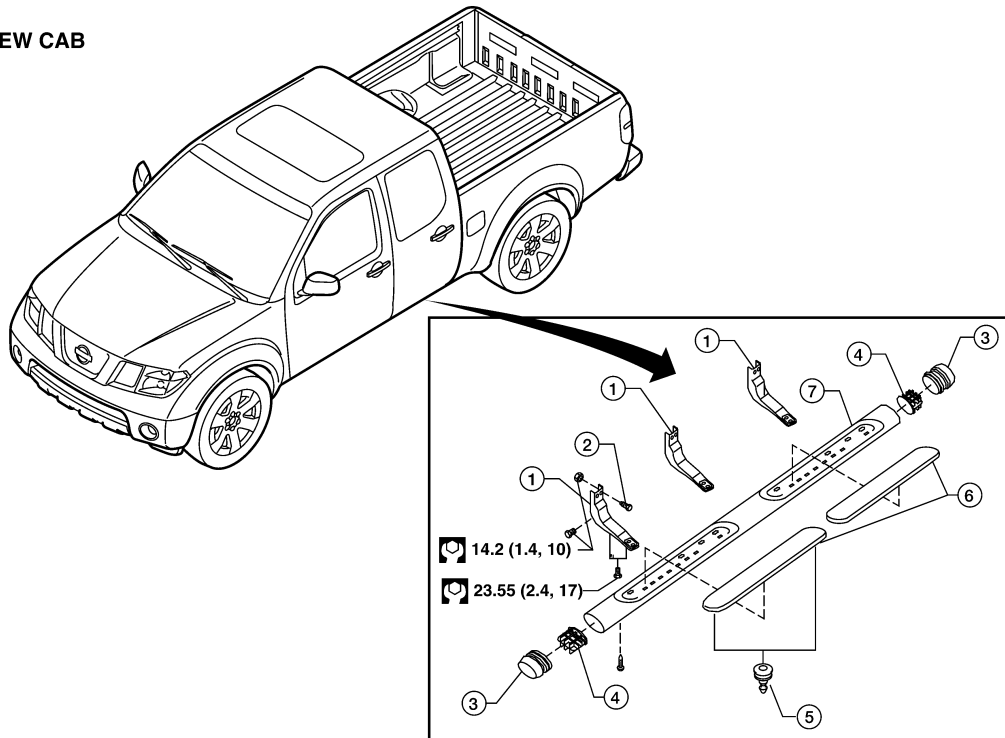

N-m (kg-m, ft-lb)

W1IA0569E

- | | | |
|--------------------------|--------------|-------------|
| 1. Running board bracket | 2. Weld stud | 3. End cap |
| 4. End cap reinforcement | 5. Clip | 6. Step pad |
| 7. Running board | | |

RUNNING BOARDS

< REMOVAL AND INSTALLATION >

REMOVAL

1. Remove bolts and remove running board from running board brackets.
2. Remove screw and remove end cap and reinforcement.
3. Release clips and remove step pad from running board.
4. Remove nuts and bolts and remove running board brackets.

INSTALLATION

Installation is in the reverse order of removal.

A

B

C

D

E

F

G

H

I

J

EXT

L

M

N

O

P

ROOF RACK

< REMOVAL AND INSTALLATION >

ROOF RACK

Removal and Installation

INFOID:000000007328513

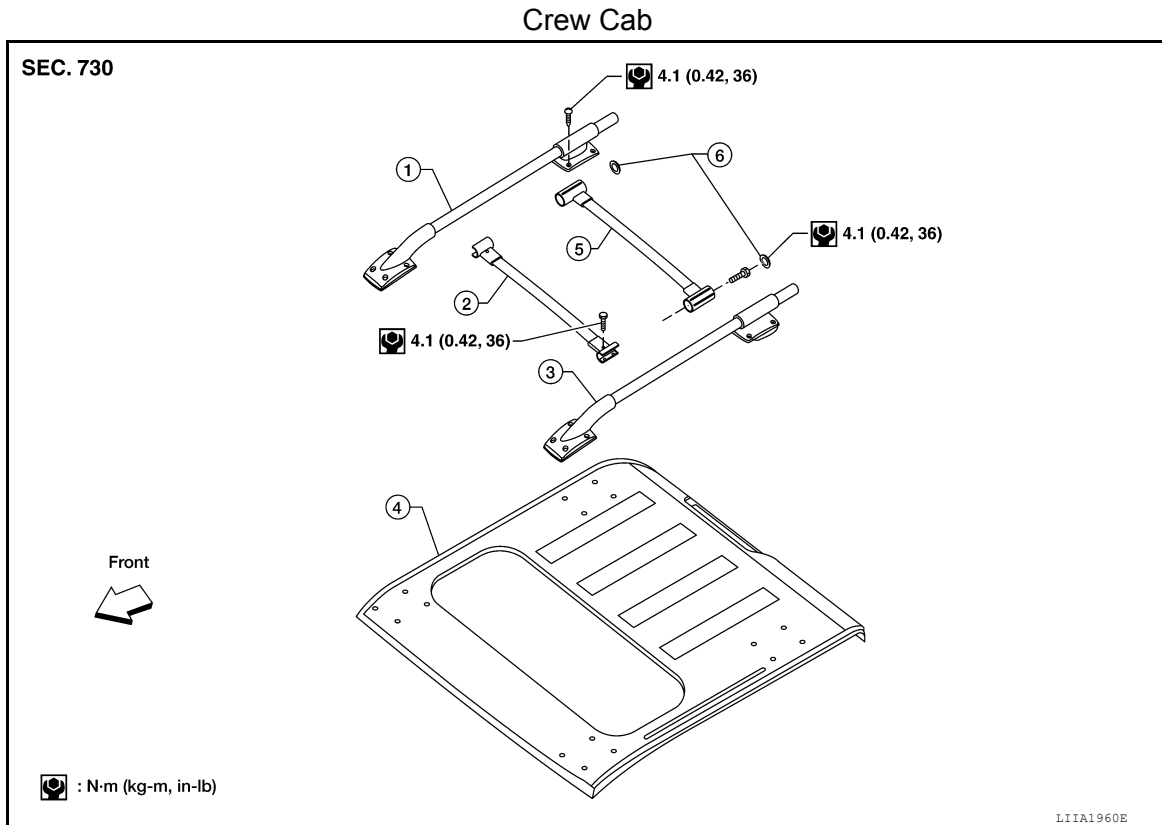

- | | | |
|-----------------|-------------------|-----------------|
| 1. RH side rail | 2. Front crossbar | 3. LH side rail |
| 4. Roof panel | 5. Rear crossbar | 6. End cap |

REMOVAL

1. Remove RH/LH side rail bolts (if equipped) from roof panel.
2. Pry outward releasing end caps and remove from side rails.
3. Remove the bolts and remove rear crossbar from side rails.
4. Remove the bolts and remove front crossbar from side rails.

INSTALLATION

Installation is in the reverse order of removal.

DOOR OUTSIDE MOLDING

< REMOVAL AND INSTALLATION >

DOOR OUTSIDE MOLDING

Removal and Installation

INFOID:000000007328514

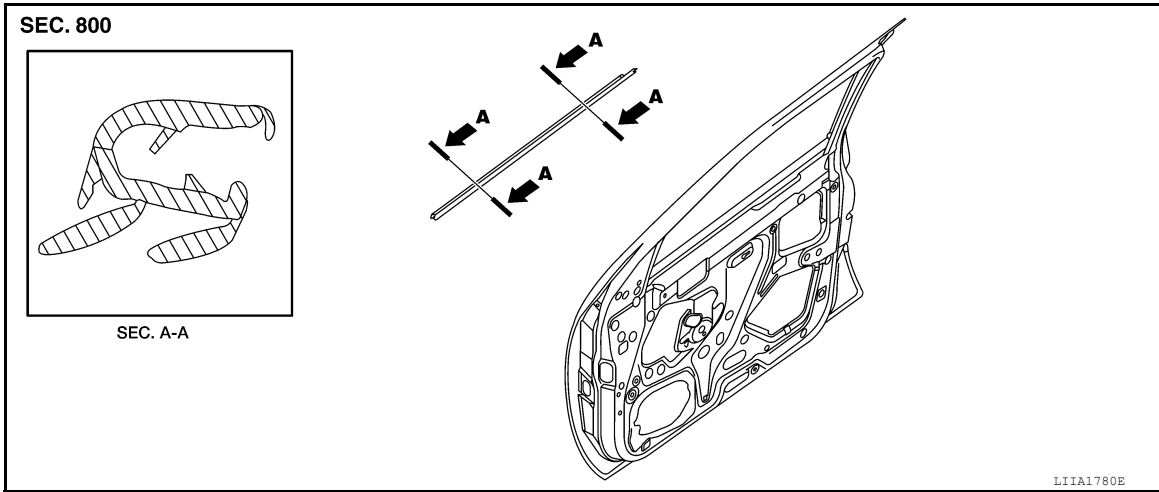

DOOR OUTSIDE MOLDING

Removal

1. Lift molding from the front side off of flange.
2. Remove the door outside molding.

Installation

Installation is in the reverse order of removal.

A
B
C
D
E
F
G
H
I
J
L
M
N
O
P

EXT

SIDE GUARD MOLDING

< REMOVAL AND INSTALLATION >

SIDE GUARD MOLDING

Removal and Installation

INFOID:000000007328515

SEC. 800•820

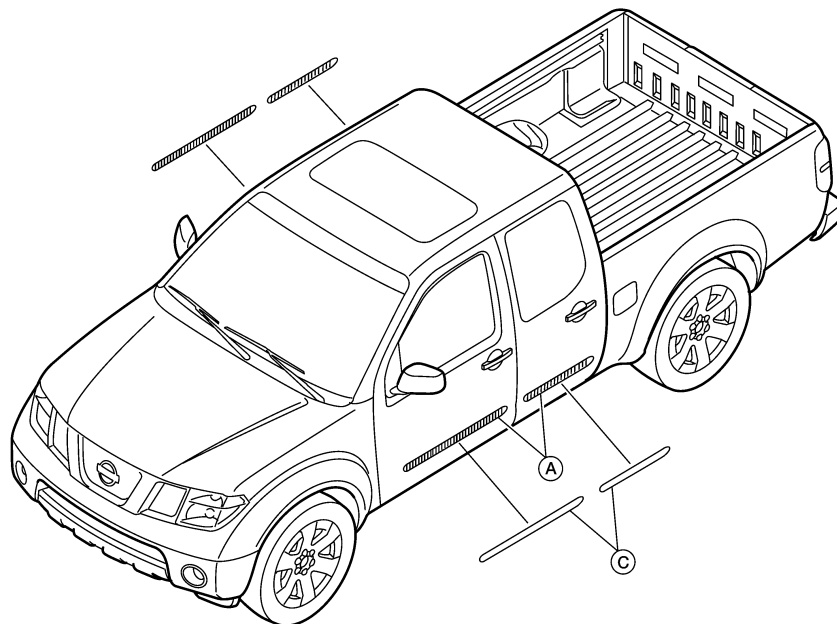
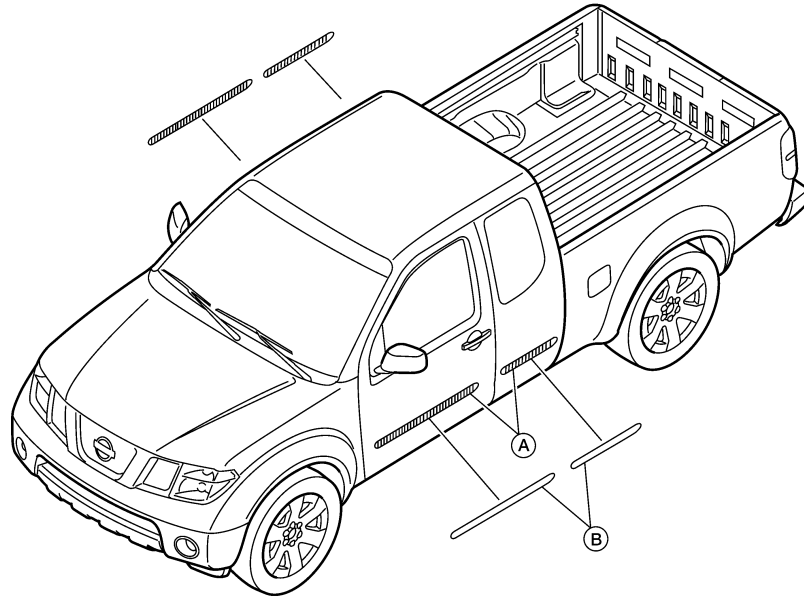

W1IA1079E

A. Double-faced adhesive tape

B. King cab side guard moulding

C. Crew cab side guard moulding

Removal

SIDE GUARD MOLDING

< REMOVAL AND INSTALLATION >

CAUTION:

Never apply tack-paper adhesive remover to body panel surface finished with lacquer-based paints.

• Original side guard molding is affixed to body panel with double-faced adhesive tape.

1. Heat molding to between 30° and 40°C (86° to 104°F) with a heat gun.
2. Raise end of molding and cut away tape to remove molding. Remove all traces of tape.

Installation

• On vehicles coated with Hard Clear Coat, use double-faced 3M adhesive tape Product No. 4210 or equivalent, after priming with 3M primer Product No. N200, C-100 or equivalent.

• The repair parts are also affixed with double-faced adhesive tape.

• To re-use existing molding, clean all traces of double sided tape from the molding and apply new double-faced tape to the molding.

1. Clean the panel surface with isopropyl alcohol or equivalent to degrease the surface.
2. Heat the panel and molding tape surface to 30° to 40°C (86° to 104°F).
3. Remove the backing sheet from the tape surface.
 - Align the locating pin into the hole in the outer door.
 - Continue aligning the pins into their corresponding holes in the outer door during installation.
4. Press ends by hand and use a roller to apply 5 kg-f (11 lbs-f) to press molding to door surface.
 - Apply even pressure along molding to insure proper wet out.

CAUTION:

To secure contact, do not wash vehicle for 24 hours after installation.

A
B
C
D
E
F
G
H
I
J
L
M
N
O
P

EXT

BED RAILS AND TRIM

< REMOVAL AND INSTALLATION >

BED RAILS AND TRIM

Removal and Installation

INFOID:000000007328516

SEC. 932•935•937

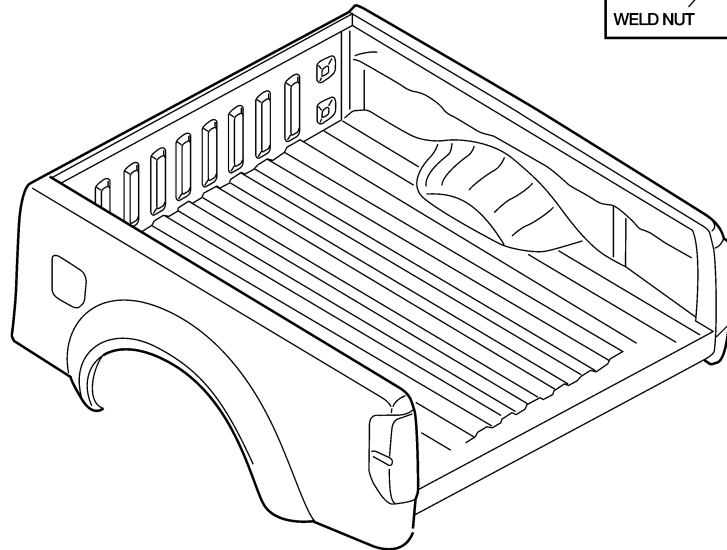
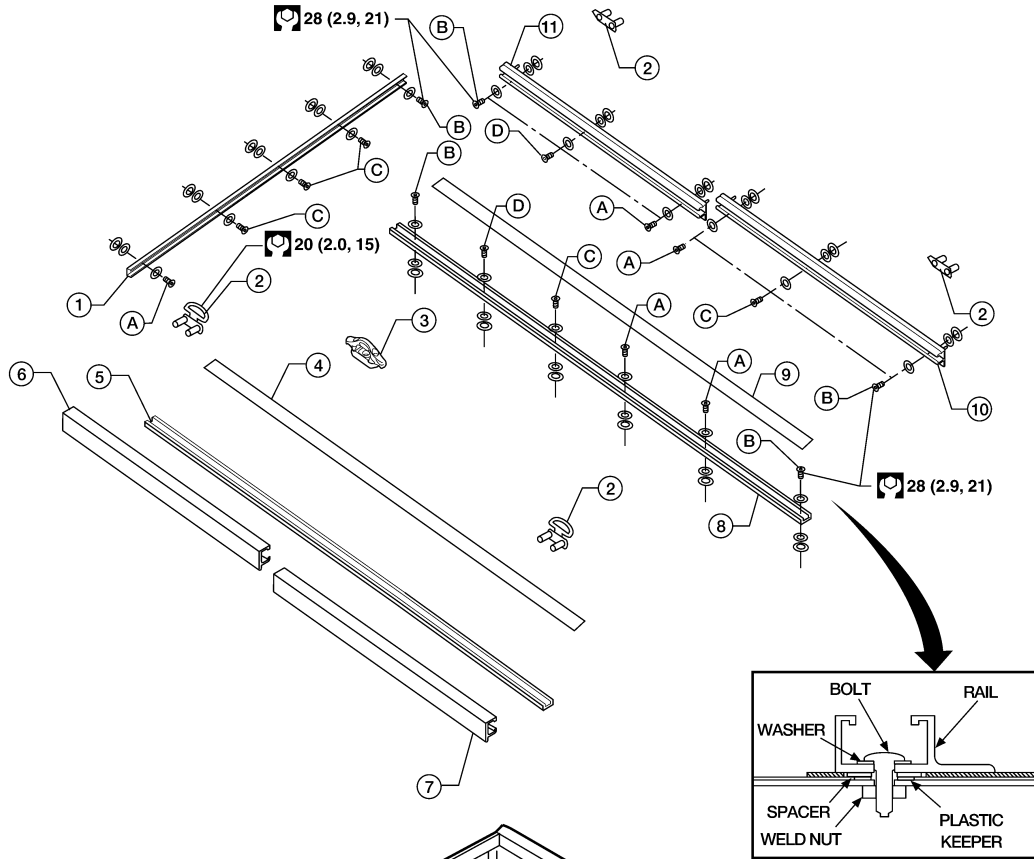

- (A) Tighten first
- (B) Tighten second
- (C) Tighten last
- (D) King cab only-tighten last

N·m (kg·m, ft·lb)

WIIA0650E

- | | | |
|-----------------------------------|------------------------------------|-----------------------------------|
| 1. Header tiedown rail | 2. Rope hook | 3. Tiedown cleat |
| 4. Floor rail cover LH | 5. Floor rail LH | 6. Bed side front tiedown rail LH |
| 7. Bed side rear tiedown rail LH | 8. Floor rail RH | 9. Floor rail cover RH |
| 10. Bed side rear tiedown rail RH | 11. Bed side front tiedown rail RH | |

BED RAILS AND TRIM

< REMOVAL AND INSTALLATION >

REMOVAL

- 1. Remove floor rail covers.
- 2. Remove tiedown cleats.
- 3. Remove floor rails LH/RH.
- 4. Remove bed side front and rear tiedown rails LH/RH.
- 5. Remove rope hooks.
- 6. Remove header tiedown rail.

INSTALLATION

Installation is in the reverse order of removal.

A
B
C
D
E
F
G
H
I
J
L
M
N
O
P

EXT

TAIL GATE FINISHER

< REMOVAL AND INSTALLATION >

TAIL GATE FINISHER

Removal and Installation

INFOID:000000007328517

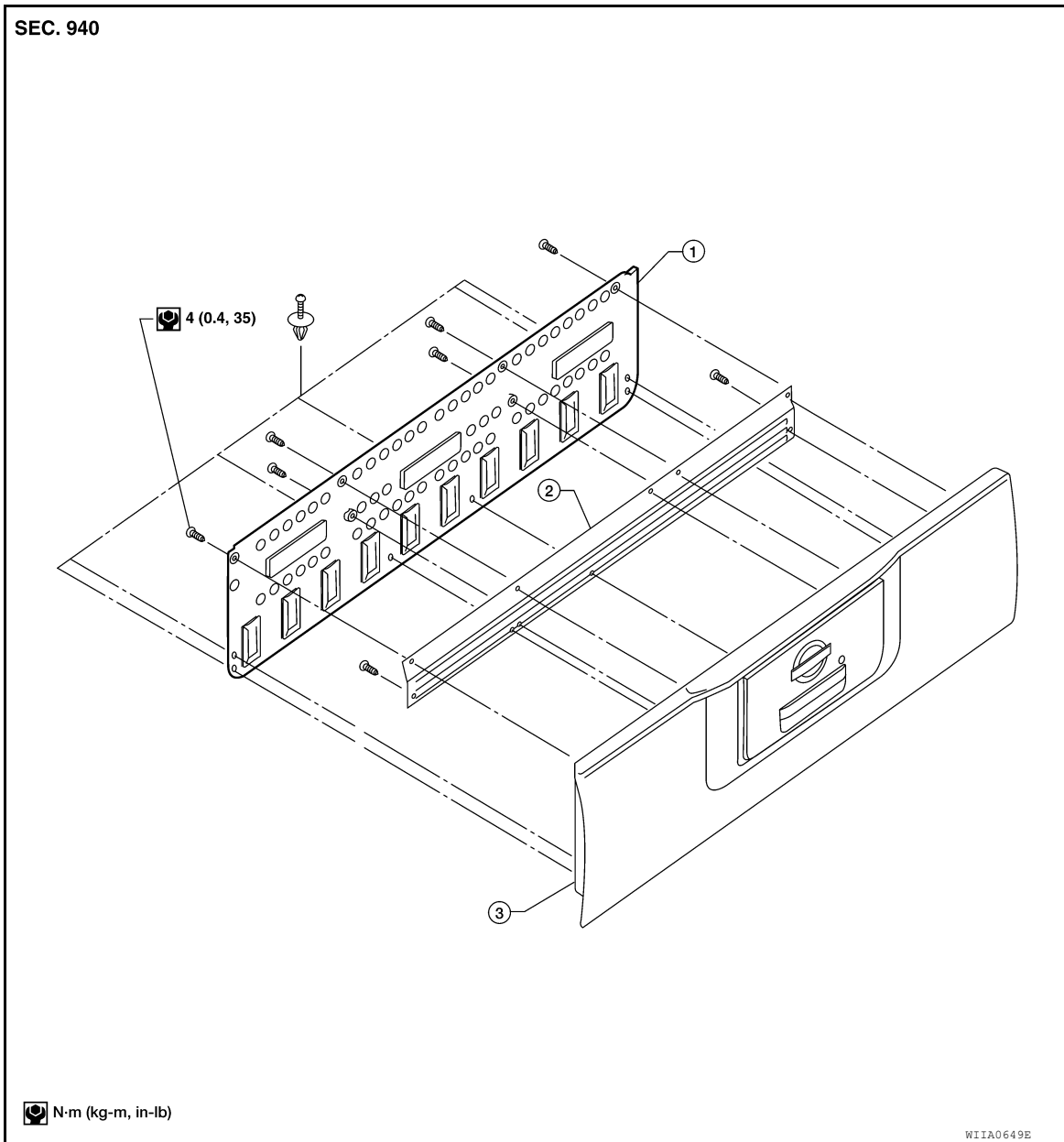

1. Tail gate protector (if equipped)

2. Tail gate cover plate

3. Tail gate

REMOVAL

Remove screws and remove tail gate protector (if equipped) and tail gate cover plate.

INSTALLATION

Installation is in the reverse order of removal.