

SECTION **SE**
SEAT

A
B
C
D
E
F
G
H
I
SE
K
L
M
N
O
P

CONTENTS

SERVICE INFORMATION	2	Precaution for Work	21
SQUEAK AND RATTLE TROUBLE DIAG- NOSES	2	PREPARATION	22
Work Flow	2	PREPARATION	22
Generic Squeak and Rattle Troubleshooting	4	Special Service Tool	22
Diagnostic Worksheet	6	Commercial Service Tool	22
DTC/CIRCUIT DIAGNOSIS	8	CLIP LIST	23
HEATED SEAT	8	Descriptions for Clips	23
Description	8	REMOVAL AND INSTALLATION	27
WIRING DIAGRAM	9	FRONT SEAT	27
POWER SEAT FOR DRIVER SIDE	9	Component	27
Wiring Diagram	9	Removal and Installation	32
POWER SEAT FOR PASSENGER SIDE	13	REAR SEAT	33
Wiring Diagram	13	Removal and Installation	33
HEATED SEAT	16	UNIT DISASSEMBLY AND ASSEMBLY ...	36
Wiring Diagram	16	FRONT SEAT	36
PRECAUTION	21	Component	36
PRECAUTIONS	21	Seatback Assembly	41
Precaution for Supplemental Restraint System (SRS) "AIR BAG" and "SEAT BELT PRE-TEN- SIONER"	21	Seat Cushion Trim and Pad	43
		REAR SEAT	45
		Disassembly and Assembly	45

SQUEAK AND RATTLE TROUBLE DIAGNOSES

< SERVICE INFORMATION >

SERVICE INFORMATION

SQUEAK AND RATTLE TROUBLE DIAGNOSES

Work Flow

INFOID:000000007831479

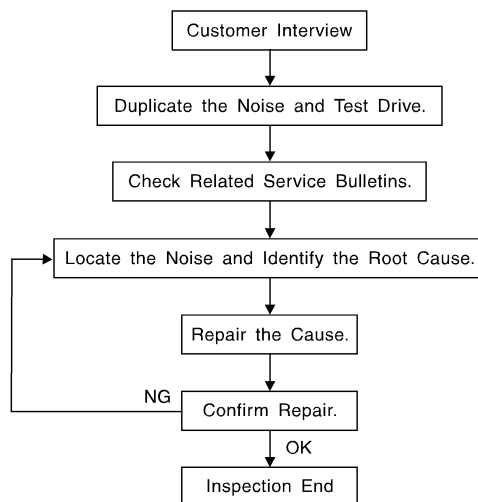

SBT842

CUSTOMER INTERVIEW

Interview the customer if possible, to determine the conditions that exist when the noise occurs. Use the Diagnostic Worksheet during the interview to document the facts and conditions when the noise occurs and any customer's comments; refer to [SE-6, "Diagnostic Worksheet"](#). This information is necessary to duplicate the conditions that exist when the noise occurs.

- The customer may not be able to provide a detailed description or the location of the noise. Attempt to obtain all the facts and conditions that exist when the noise occurs (or does not occur).
- If there is more than one noise in the vehicle, be sure to diagnose and repair the noise that the customer is concerned about. This can be accomplished by test driving the vehicle with the customer.
- After identifying the type of noise, isolate the noise in terms of its characteristics. The noise characteristics are provided so the customer, service adviser and technician are all speaking the same language when defining the noise.
- Squeak —(Like tennis shoes on a clean floor)
Squeak characteristics include the light contact/fast movement/brought on by road conditions/hard surfaces = higher pitch noise/softer surfaces = lower pitch noises/edge to surface = chirping.
- Creak—(Like walking on an old wooden floor)
Creak characteristics include firm contact/slow movement/twisting with a rotational movement/pitch dependent on materials/often brought on by activity.
- Rattle—(Like shaking a baby rattle)
Rattle characteristics include the fast repeated contact/vibration or similar movement/loose parts/missing clip or fastener/incorrect clearance.
- Knock —(Like a knock on a door)
Knock characteristics include hollow sounding/sometimes repeating/often brought on by driver action.
- Tick—(Like a clock second hand)
Tick characteristics include gentle contacting of light materials/loose components/can be caused by driver action or road conditions.
- Thump—(Heavy, muffled knock noise)
Thump characteristics include softer knock/dead sound often brought on by activity.
- Buzz—(Like a bumble bee)
Buzz characteristics include high frequency rattle/firm contact.
- Often the degree of acceptable noise level will vary depending upon the person. A noise that you may judge as acceptable may be very irritating to the customer.
- Weather conditions, especially humidity and temperature, may have a great effect on noise level.

DUPLICATE THE NOISE AND TEST DRIVE

SQUEAK AND RATTLE TROUBLE DIAGNOSES

< SERVICE INFORMATION >

If possible, drive the vehicle with the customer until the noise is duplicated. Note any additional information on the Diagnostic Worksheet regarding the conditions or location of the noise. This information can be used to duplicate the same conditions when you confirm the repair.

If the noise can be duplicated easily during the test drive, to help identify the source of the noise, try to duplicate the noise with the vehicle stopped by doing one or all of the following:

- 1) Close a door.
 - 2) Tap or push/pull around the area where the noise appears to be coming from.
 - 3) Rev the engine.
 - 4) Use a floor jack to recreate vehicle "twist".
 - 5) At idle, apply engine load (electrical load, half-clutch on M/T model, drive position on CVT and A/T models).
 - 6) Raise the vehicle on a hoist and hit a tire with a rubber hammer.
- Drive the vehicle and attempt to duplicate the conditions the customer states exist when the noise occurs.
 - If it is difficult to duplicate the noise, drive the vehicle slowly on an undulating or rough road to stress the vehicle body.

CHECK RELATED SERVICE BULLETINS

After verifying the customer concern or symptom, check ASIST for Technical Service Bulletins (TSBs) related to that concern or symptom.

If a TSB relates to the symptom, follow the procedure to repair the noise.

LOCATE THE NOISE AND IDENTIFY THE ROOT CAUSE

1. Narrow down the noise to a general area. To help pinpoint the source of the noise, use a listening tool (Chassis Ear: J-39570, Engine Ear: J-39565 and mechanic's stethoscope).
2. Narrow down the noise to a more specific area and identify the cause of the noise by:
 - removing the components in the area that you suspect the noise is coming from.
Do not use too much force when removing clips and fasteners, otherwise clips and fasteners can be broken or lost during the repair, resulting in the creation of new noise.
 - tapping or pushing/pulling the component that you suspect is causing the noise.
Do not tap or push/pull the component with excessive force, otherwise the noise will be eliminated only temporarily.
 - feeling for a vibration with your hand by touching the component(s) that you suspect is (are) causing the noise.
 - placing a piece of paper between components that you suspect are causing the noise.
 - looking for loose components and contact marks.Refer to [SE-4. "Generic Squeak and Rattle Troubleshooting"](#).

REPAIR THE CAUSE

- If the cause is a loose component, tighten the component securely.
- If the cause is insufficient clearance between components:
 - separate components by repositioning or loosening and retightening the component, if possible.
 - insulate components with a suitable insulator such as urethane pads, foam blocks, felt cloth tape or urethane tape. A NISSAN Squeak and Rattle Kit (J-43980) is available through your authorized NISSAN Parts Department.

CAUTION:

Do not use excessive force as many components are constructed of plastic and may be damaged.

Always check with the Parts Department for the latest parts information.

The following materials are contained in the NISSAN Squeak and Rattle Kit (J-43980). Each item can be ordered separately as needed.

URETHANE PADS [1.5 mm (0.059 in) thick]

Insulates connectors, harness, etc.

76268-9E005: 100×135 mm (3.94×5.31 in)/76884-71L01: 60×85 mm (2.36×3.35 in)/76884-71L02: 15×25 mm (0.59×0.98 in)

INSULATOR (Foam blocks)

Insulates components from contact. Can be used to fill space behind a panel.

73982-9E000: 45 mm (1.77 in) thick, 50×50 mm (1.97×1.97 in)/73982-50Y00: 10 mm (0.39 in) thick, 50×50 mm (1.97×1.97 in)

INSULATOR (Light foam block)

80845-71L00: 30 mm (1.18 in) thick, 30×50 mm (1.18×1.97 in)

FELT CLOTH TAPE

Used to insulate where movement does not occur. Ideal for instrument panel applications.

68370-4B000: 15×25 mm (0.59×0.98 in) pad/68239-13E00: 5 mm (0.20 in) wide tape roll. The following materials not found in the kit can also be used to repair squeaks and rattles.

SQUEAK AND RATTLE TROUBLE DIAGNOSES

< SERVICE INFORMATION >

UHMW (TEFLON) TAPE

Insulates where slight movement is present. Ideal for instrument panel applications.

SILICONE GREASE

Used instead of UHMW tape that will be visible or not fit.

Note: Will only last a few months.

SILICONE SPRAY

Use when grease cannot be applied.

DUCT TAPE

Use to eliminate movement.

CONFIRM THE REPAIR

Confirm that the cause of a noise is repaired by test driving the vehicle. Operate the vehicle under the same conditions as when the noise originally occurred. Refer to the notes on the Diagnostic Worksheet.

Generic Squeak and Rattle Troubleshooting

INFOID:000000007831480

Refer to Table of Contents for specific component removal and installation information.

INSTRUMENT PANEL

Most incidents are caused by contact and movement between:

1. The cluster lid A and instrument panel
2. Acrylic lens and combination meter housing
3. Instrument panel to front pillar garnish
4. Instrument panel to windshield
5. Instrument panel pins
6. Wiring harnesses behind the combination meter
7. A/C defroster duct and duct joint

These incidents can usually be located by tapping or moving the components to duplicate the noise or by pressing on the components while driving to stop the noise. Most of these incidents can be repaired by applying felt cloth tape or silicone spray (in hard to reach areas). Urethane pads can be used to insulate wiring harness.

CAUTION:

Do not use silicone spray to isolate a squeak or rattle. If you saturate the area with silicone, you will not be able to recheck the repair.

CENTER CONSOLE

Components to pay attention to include:

1. Shift selector assembly cover to finisher
2. A/C control unit and cluster lid C
3. Wiring harnesses behind audio and A/C control unit

The instrument panel repair and isolation procedures also apply to the center console.

DOORS

Pay attention to the:

1. Finisher and inner panel making a slapping noise
2. Inside handle escutcheon to door finisher
3. Wiring harnesses tapping
4. Door striker out of alignment causing a popping noise on starts and stops

Tapping or moving the components or pressing on them while driving to duplicate the conditions can isolate many of these incidents. You can usually insulate the areas with felt cloth tape or insulator foam blocks from the NISSAN Squeak and Rattle Kit (J-43980) to repair the noise.

TRUNK

Trunk noises are often caused by a loose jack or loose items put into the trunk by the owner.

In addition look for:

1. Trunk lid bumpers out of adjustment
2. Trunk lid striker out of adjustment
3. The trunk lid torsion bars knocking together

SQUEAK AND RATTLE TROUBLE DIAGNOSES

< SERVICE INFORMATION >

4. A loose license plate or bracket

Most of these incidents can be repaired by adjusting, securing or insulating the item(s) or component(s) causing the noise.

SUNROOF/HEADLINING

Noises in the sunroof/headlining area can often be traced to one of the following:

1. Sunroof lid, rail, linkage or seals making a rattle or light knocking noise
2. Sun visor shaft shaking in the holder
3. Front or rear windshield touching headliner and squeaking

Again, pressing on the components to stop the noise while duplicating the conditions can isolate most of these incidents. Repairs usually consist of insulating with felt cloth tape.

OVERHEAD CONSOLE (FRONT AND REAR)

Overhead console noises are often caused by the console panel clips not being engaged correctly. Most of these incidents are repaired by pushing up on the console at the clip locations until the clips engage.

In addition look for:

1. Loose harness or harness connectors.
2. Front console map/reading lamp lens loose.
3. Loose screws at console attachment points.

SEATS

When isolating seat noise it's important to note the position the seat is in and the load placed on the seat when the noise is present. These conditions should be duplicated when verifying and isolating the cause of the noise.

Cause of seat noise include:

1. Headrest rods and holder
2. A squeak between the seat pad cushion and frame
3. The rear seatback lock and bracket

These noises can be isolated by moving or pressing on the suspected components while duplicating the conditions under which the noise occurs. Most of these incidents can be repaired by repositioning the component or applying urethane tape to the contact area.

UNDERHOOD

Some interior noise may be caused by components under the hood or on the engine wall. The noise is then transmitted into the passenger compartment.

Causes of transmitted underhood noise include:

1. Any component installed to the engine wall
2. Components that pass through the engine wall
3. Engine wall mounts and connectors
4. Loose radiator installation pins
5. Hood bumpers out of adjustment
6. Hood striker out of adjustment

These noises can be difficult to isolate since they cannot be reached from the interior of the vehicle. The best method is to secure, move or insulate one component at a time and test drive the vehicle. Also, engine rpm or load can be changed to isolate the noise. Repairs can usually be made by moving, adjusting, securing, or insulating the component causing the noise.

A
B
C
D
E
F
G
H
I
SE
K
L
M
N
O
P

SQUEAK AND RATTLE TROUBLE DIAGNOSES

< SERVICE INFORMATION >

Diagnostic Worksheet

INFOID:000000007831481

Dear Customer:

We are concerned about your satisfaction with your vehicle. Repairing a squeak or rattle sometimes can be very difficult. To help us fix your vehicle right the first time, please take a moment to note the area of the vehicle where the squeak or rattle occurs and under what conditions. You may be asked to take a test drive with a service advisor or technician to ensure we confirm the noise you are hearing.

SQUEAK & RATTLE DIAGNOSTIC WORKSHEET

I. WHERE DOES THE NOISE COME FROM? (circle the area of the vehicle)

The illustrations are for reference only, and may not reflect the actual configuration of your vehicle.

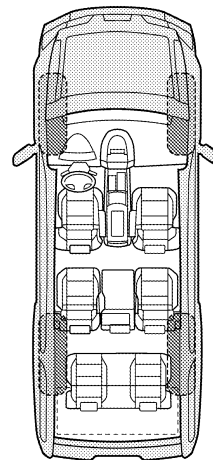

Continue to page 2 of the worksheet and briefly describe the location of the noise or rattle. In addition, please indicate the conditions which are present when the noise occurs.

SQUEAK AND RATTLE TROUBLE DIAGNOSES

< SERVICE INFORMATION >

SQUEAK & RATTLE DIAGNOSTIC WORKSHEET - page 2

Briefly describe the location where the noise occurs:

II. WHEN DOES IT OCCUR? (please check the boxes that apply)

- | | |
|---|--|
| <input type="checkbox"/> Anytime | <input type="checkbox"/> After sitting out in the rain |
| <input type="checkbox"/> 1st time in the morning | <input type="checkbox"/> When it is raining or wet |
| <input type="checkbox"/> Only when it is cold outside | <input type="checkbox"/> Dry or dusty conditions |
| <input type="checkbox"/> Only when it is hot outside | <input type="checkbox"/> Other: |

III. WHEN DRIVING:

- Through driveways
- Over rough roads
- Over speed bumps
- Only about ____ mph
- On acceleration
- Coming to a stop
- On turns: left, right or either (circle)
- With passengers or cargo
- Other: _____
- After driving ____ miles or ____ minutes

IV. WHAT TYPE OF NOISE

- Squeak (like tennis shoes on a clean floor)
- Creak (like walking on an old wooden floor)
- Rattle (like shaking a baby rattle)
- Knock (like a knock at the door)
- Tick (like a clock second hand)
- Thump (heavy muffled knock noise)
- Buzz (like a bumble bee)

TO BE COMPLETED BY DEALERSHIP PERSONNEL

Test Drive Notes:

	YES	NO	Initials of person performing
Vehicle test driven with customer	<input type="checkbox"/>	<input type="checkbox"/>	_____
- Noise verified on test drive	<input type="checkbox"/>	<input type="checkbox"/>	_____
- Noise source located and repaired	<input type="checkbox"/>	<input type="checkbox"/>	_____
- Follow up test drive performed to confirm repair	<input type="checkbox"/>	<input type="checkbox"/>	_____

VIN: _____ Customer Name _____

W.O.# _____ Date: _____

This form must be attached to Work Order

LATA0071E

HEATED SEAT

< DTC/CIRCUIT DIAGNOSIS >

DTC/CIRCUIT DIAGNOSIS

HEATED SEAT

Description

INFOID:000000007328521

- When handling seat, be extremely careful not to scratch heating unit (1).
- To replace heating unit, seat trim and pad should be separated for the front seat cushion LH. For seatback and front seat cushion RH, complete cushion (2) or seatback assembly (3) must be replaced.
- Do not use any organic solvent, such as thinner, benzene, alcohol, etc. to clean trim.

Thermostat operation	ON	OFF
Trim temperature °C (°F)	25 -35 (77 - 95)	35 - 45 (95 - 113)

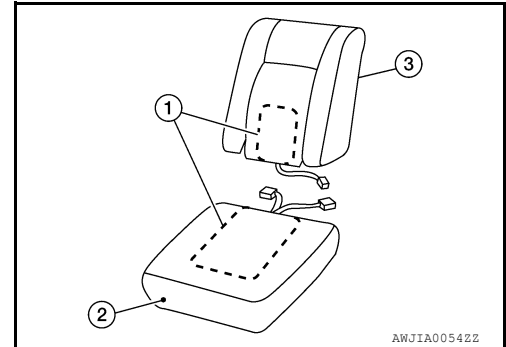

POWER SEAT FOR DRIVER SIDE

< WIRING DIAGRAM >

WIRING DIAGRAM

POWER SEAT FOR DRIVER SIDE

Wiring Diagram

INFOID:000000007328522

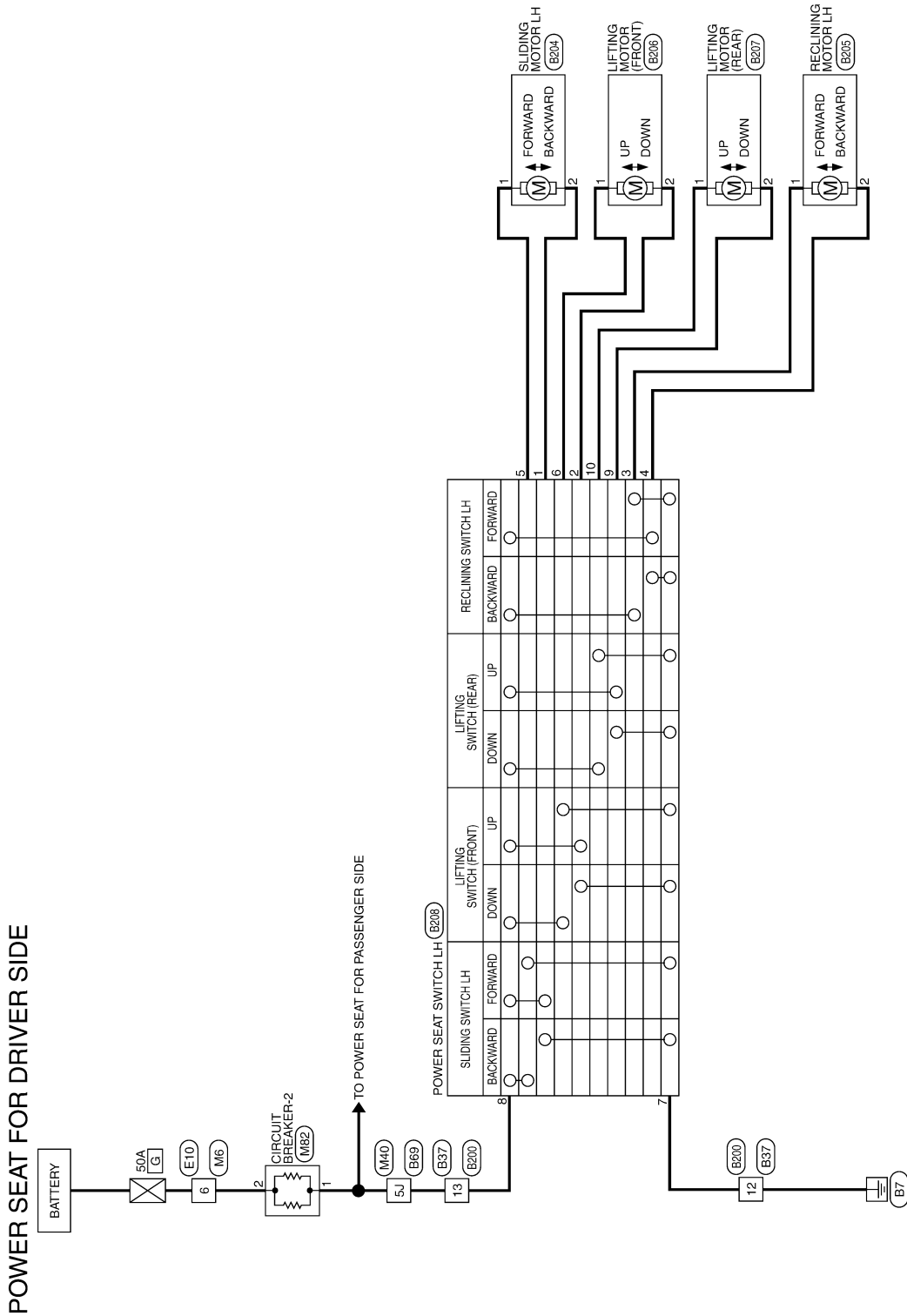

A
B
C
D
E
F
G
H
I
SE
K
L
M
N
O
P

POWER SEAT FOR DRIVER SIDE

< WIRING DIAGRAM >

POWER SEAT FOR DRIVER SIDE CONNECTORS

Connector No.	M6
Connector Name	WIRE TO WIRE
Connector Color	WHITE



Terminal No.	6	Color of Wire	W	Signal Name	-
--------------	---	---------------	---	-------------	---

Connector No.	M40
Connector Name	WIRE TO WIRE
Connector Color	WHITE

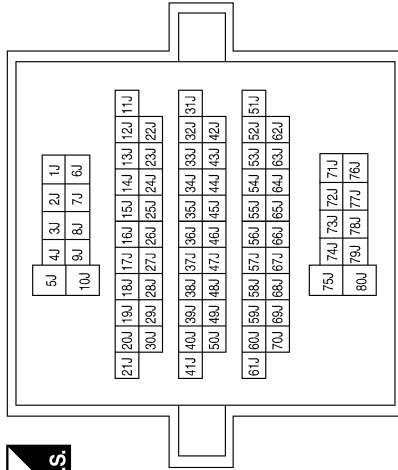

Terminal No.	5J	Color of Wire	G	Signal Name	-
--------------	----	---------------	---	-------------	---

Connector No.	M82
Connector Name	CIRCUIT BREAKER-2
Connector Color	WHITE



Terminal No.	1	Color of Wire	G	Signal Name	-
Terminal No.	2	Color of Wire	P	Signal Name	-

Connector No.	E10
Connector Name	WIRE TO WIRE
Connector Color	WHITE



Terminal No.	6	Color of Wire	W	Signal Name	-
--------------	---	---------------	---	-------------	---

Connector No.	B37
Connector Name	WIRE TO WIRE
Connector Color	WHITE

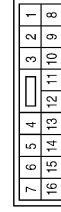

Terminal No.	12	Color of Wire	B	Signal Name	-
Terminal No.	13	Color of Wire	G	Signal Name	-

POWER SEAT FOR DRIVER SIDE

< WIRING DIAGRAM >

Connector No.	B69
Connector Name	WIRE TO WIRE
Connector Color	WHITE

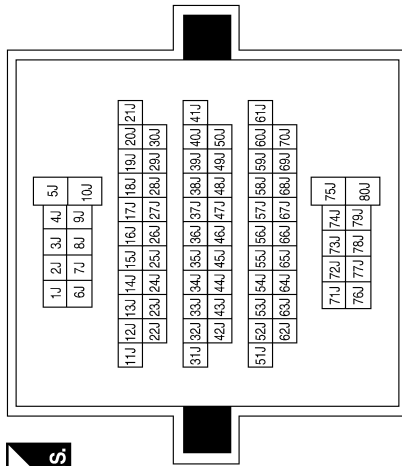

Terminal No.	5J	Color of Wire	G	Signal Name	-
--------------	----	---------------	---	-------------	---

Connector No.	B200
Connector Name	WIRE TO WIRE
Connector Color	WHITE

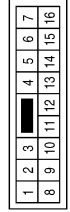

Terminal No.	12	Color of Wire	B	Signal Name	-
	13		G		-

Connector No.	B204
Connector Name	SLIDING MOTOR LH
Connector Color	GRAY



Connector No.	B205
Connector Name	RECLINING MOTOR LH
Connector Color	WHITE



Connector No.	B206
Connector Name	LIFTING MOTOR (FRONT)
Connector Color	GRAY



Terminal No.	1	Color of Wire	R	Signal Name	-
	2		G		-

Terminal No.	1	Color of Wire	R/W	Signal Name	-
	2		G/W		-

Terminal No.	1	Color of Wire	Y	Signal Name	-
	2		Y/B		-

ABJIA0179GB

A
B
C
D
E
F
G
H
I
SE
K
L
M
N
O
P

POWER SEAT FOR DRIVER SIDE

< WIRING DIAGRAM >

Connector No.	B208
Connector Name	POWER SEAT SWITCH LH
Connector Color	WHITE

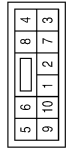

Terminal No.	Color of Wire	Signal Name
1	G	-
2	Y	-
3	G/W	-
4	R/W	-
5	R	-
6	Y/B	-
7	B	-
8	W/L	-
9	L/W	-
10	L	-

Connector No.	B207
Connector Name	LIFTING MOTOR (REAR)
Connector Color	GRAY



Terminal No.	Color of Wire	Signal Name
1	L	-
2	L/W	-

ABJIA0576GB

POWER SEAT FOR PASSENGER SIDE

< WIRING DIAGRAM >

POWER SEAT FOR PASSENGER SIDE

Wiring Diagram

INFOID:000000007328523

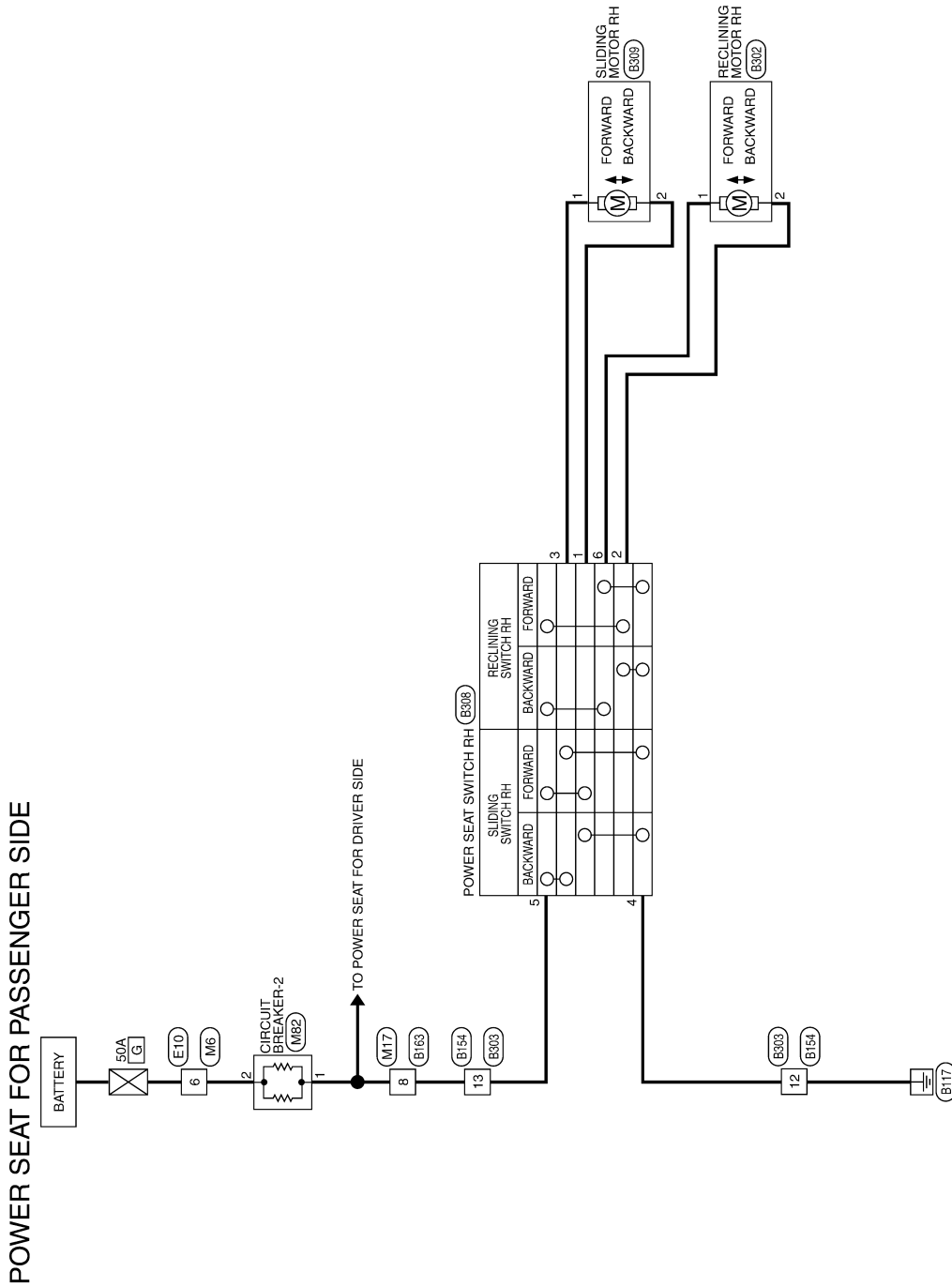

A
B
C
D
E
F
G
H
I
SE
K
L
M
N
O
P

ABJWA0058GB

POWER SEAT FOR PASSENGER SIDE

< WIRING DIAGRAM >

POWER SEAT FOR PASSENGER SIDE CONNECTORS

Connector No.	M6
Connector Name	WIRE TO WIRE
Connector Color	WHITE



3	2	1
6	5	4

Terminal No.	6	Color of Wire	W	Signal Name	-
--------------	---	---------------	---	-------------	---

Connector No.	M17
Connector Name	WIRE TO WIRE
Connector Color	WHITE



7	6	5	4	3	2	1
16	15	14	13	12	11	10
9	8					

Terminal No.	8	Color of Wire	LG	Signal Name	-
--------------	---	---------------	----	-------------	---

Connector No.	M82
Connector Name	CIRCUIT BREAKER-2
Connector Color	WHITE



1	2
---	---

Terminal No.	1	Color of Wire	G	Signal Name	-
	2	Color of Wire	P	Signal Name	-

Connector No.	E10
Connector Name	WIRE TO WIRE
Connector Color	WHITE



1	2	3
4	5	6

Terminal No.	6	Color of Wire	W	Signal Name	-
--------------	---	---------------	---	-------------	---

Connector No.	B154
Connector Name	WIRE TO WIRE
Connector Color	WHITE



7	6	5	4	3	2	1
16	15	14	13	12	11	10
9	8					

Terminal No.	12	Color of Wire	B	Signal Name	-
	13	Color of Wire	LG	Signal Name	-

Connector No.	B163
Connector Name	WIRE TO WIRE
Connector Color	WHITE



1	2	3	4	5	6	7
8	9	10	11	12	13	14
15	16					

Terminal No.	8	Color of Wire	LG	Signal Name	-
--------------	---	---------------	----	-------------	---

POWER SEAT FOR PASSENGER SIDE

< WIRING DIAGRAM >

Connector No.	B308
Connector Name	POWER SEAT SWITCH RH
Connector Color	WHITE



Terminal No.	Color of Wire	Signal Name
1	Y	-
2	Y/B	-
3	G	-
4	B	-
5	W/L	-
6	G/B	-

Connector No.	B303
Connector Name	WIRE TO WIRE
Connector Color	WHITE

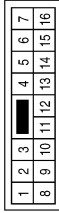

Terminal No.	Color of Wire	Signal Name
12	B	-
13	W/L	-

Connector No.	B302
Connector Name	RECLINING MOTOR RH
Connector Color	WHITE



Terminal No.	Color of Wire	Signal Name
1	G/B	-
2	Y/B	-

Connector No.	B309
Connector Name	SLIDING MOTOR RH
Connector Color	GRAY



Terminal No.	Color of Wire	Signal Name
1	G	-
2	Y	-

ABJIA0180GB

A
B
C
D
E
F
G
H
I
SE
K
L
M
N
O
P

HEATED SEAT

< WIRING DIAGRAM >

HEATED SEAT

Wiring Diagram

INFOID:000000007328524

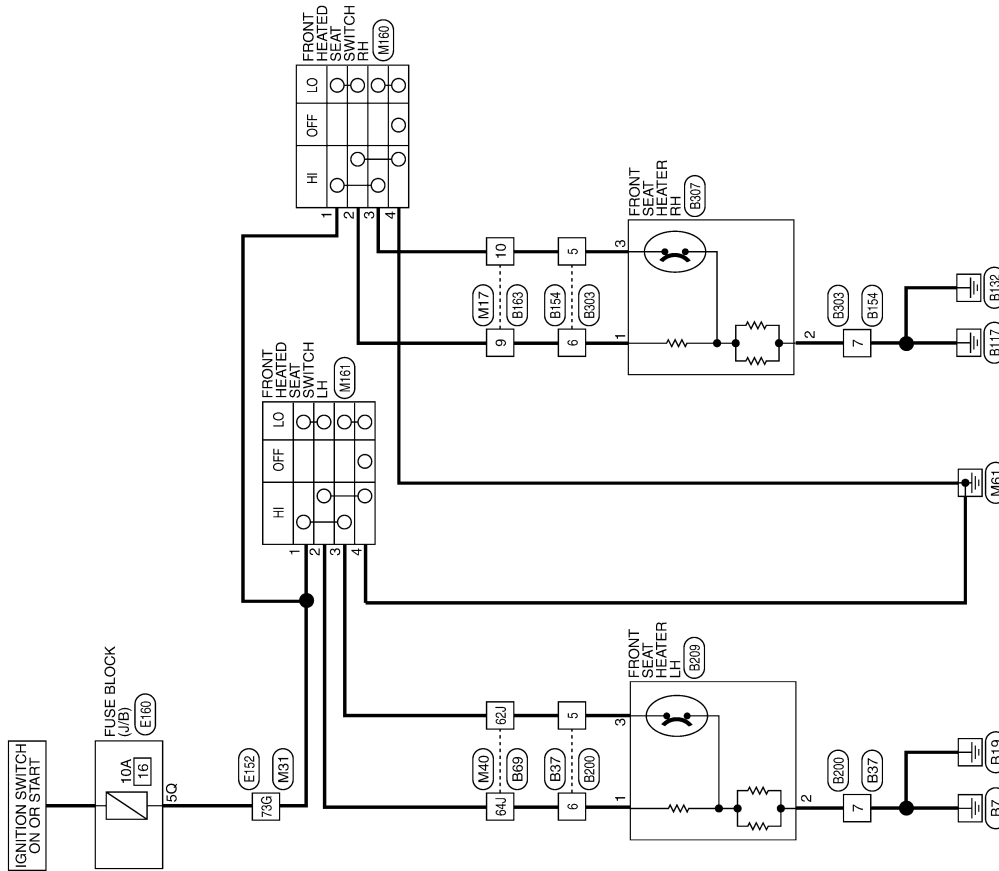

HEATED SEAT

ABJWA0059GB

HEATED SEAT

< WIRING DIAGRAM >

HEATED SEAT CONNECTORS

Connector No.	M17
Connector Name	WIRE TO WIRE
Connector Color	WHITE

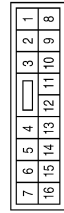

Terminal No.	Color of Wire	Signal Name
9	W	-
10	GR	-

Connector No.	M31
Connector Name	WIRE TO WIRE
Connector Color	WHITE

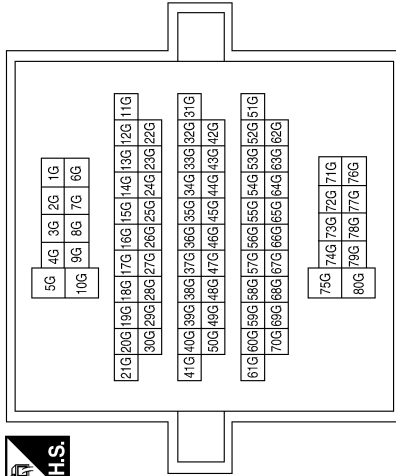

Terminal No.	73G	Color of Wire	W/R	Signal Name	-
--------------	-----	---------------	-----	-------------	---

Connector No.	M40
Connector Name	WIRE TO WIRE
Connector Color	WHITE

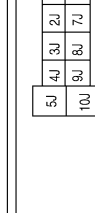

Terminal No.	62J	Color of Wire	LG	Signal Name	-
64J	GR	GR	GR	-	-

Connector No.	M160
Connector Name	FRONT HEATED SEAT SWITCH RH
Connector Color	BROWN



Terminal No.	Color of Wire	Signal Name
1	G	-
2	W	-
3	GR	-
4	B	-

ABJIA0181GB

A
B
C
D
E
F
G
H
I
SE
K
L
M
N
O
P

HEATED SEAT

< WIRING DIAGRAM >

Terminal No.	Color of Wire	Signal Name
73G	W/R	-

Connector No.	E152
Connector Name	WIRE TO WIRE
Connector Color	WHITE

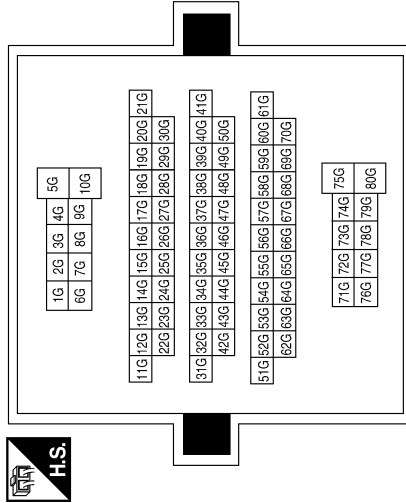

Connector No.	M161
Connector Name	FRONT HEATED SEAT SWITCH LH
Connector Color	WHITE



Terminal No.	Color of Wire	Signal Name
1	W/R	-
2	GR	-
3	LG	-
4	B	-

Connector No.	B37
Connector Name	WIRE TO WIRE
Connector Color	WHITE

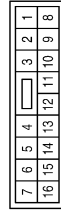

Terminal No.	Color of Wire	Signal Name
5	LG	-
6	GR	-
7	B	-

Connector No.	E160
Connector Name	FUSE BLOCK (J/B)
Connector Color	WHITE

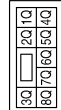

Terminal No.	Color of Wire	Signal Name
5Q	W/R	-

ABJIA0182GB

HEATED SEAT

< WIRING DIAGRAM >

Connector No.	B154
Connector Name	WIRE TO WIRE
Connector Color	WHITE

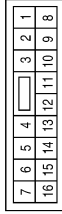

Terminal No.	Color of Wire	Signal Name
5	GR	-
6	W	-
7	B	-

Terminal No.	Color of Wire	Signal Name
62J	LG	-
64J	GR	-

Connector No.	B69
Connector Name	WIRE TO WIRE
Connector Color	WHITE

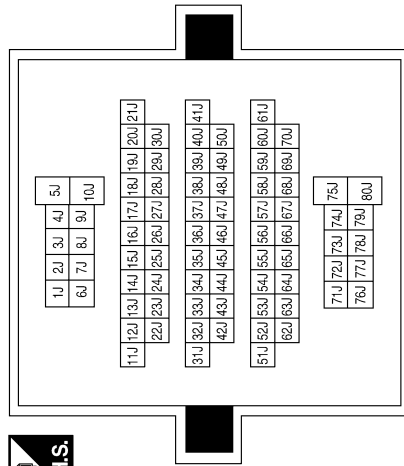

Connector No.	B209
Connector Name	FRONT SEAT HEATER LH
Connector Color	WHITE



Terminal No.	Color of Wire	Signal Name
1	Y	-
2	G/W	-
3	Y/B	-

Connector No.	B200
Connector Name	WIRE TO WIRE
Connector Color	WHITE

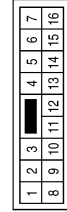

Terminal No.	Color of Wire	Signal Name
5	Y/B	-
6	Y	-
7	G/W	-

Connector No.	B163
Connector Name	WIRE TO WIRE
Connector Color	WHITE

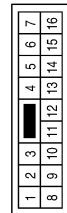

Terminal No.	Color of Wire	Signal Name
9	W	-
10	GR	-

ABJIA0386GB

A
B
C
D
E
F
G
H
I
SE
K
L
M
N
O
P

HEATED SEAT

< WIRING DIAGRAM >

Connector No.	B307
Connector Name	FRONT SEAT HEATER RH
Connector Color	WHITE



Terminal No.	Color of Wire	Signal Name
1	Y	-
2	G/W	-
3	Y/B	-

Connector No.	B303
Connector Name	WIRE TO WIRE
Connector Color	WHITE

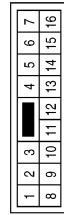

Terminal No.	Color of Wire	Signal Name
5	Y/B	-
6	Y	-
7	G/W	-

ABJIA0184GB

PRECAUTIONS

< PRECAUTION >

PRECAUTION

PRECAUTIONS

Precaution for Supplemental Restraint System (SRS) "AIR BAG" and "SEAT BELT PRE-TENSIONER"

INFOID:000000007328525

The Supplemental Restraint System such as "AIR BAG" and "SEAT BELT PRE-TENSIONER", used along with a front seat belt, helps to reduce the risk or severity of injury to the driver and front passenger for certain types of collision. This system includes seat belt switch inputs and dual stage front air bag modules. The SRS system uses the seat belt switches to determine the front air bag deployment, and may only deploy one front air bag, depending on the severity of a collision and whether the front occupants are belted or unbelted. Information necessary to service the system safely is included in the SR and SB section of this Service Manual.

WARNING:

- To avoid rendering the SRS inoperative, which could increase the risk of personal injury or death in the event of a collision which would result in air bag inflation, all maintenance must be performed by an authorized NISSAN/INFINITI dealer.
- Improper maintenance, including incorrect removal and installation of the SRS, can lead to personal injury caused by unintentional activation of the system. For removal of Spiral Cable and Air Bag Module, see the SR section.
- Do not use electrical test equipment on any circuit related to the SRS unless instructed to in this Service Manual. SRS wiring harnesses can be identified by yellow and/or orange harnesses or harness connectors.

PRECAUTIONS WHEN USING POWER TOOLS (AIR OR ELECTRIC) AND HAMMERS

WARNING:

- When working near the Airbag Diagnosis Sensor Unit or other Airbag System sensors with the Ignition ON or engine running, DO NOT use air or electric power tools or strike near the sensor(s) with a hammer. Heavy vibration could activate the sensor(s) and deploy the air bag(s), possibly causing serious injury.
- When using air or electric power tools or hammers, always switch the Ignition OFF, disconnect the battery, and wait at least 3 minutes before performing any service.

Precaution for Work

INFOID:000000009002499

- When removing or disassembling each component, be careful not to damage or deform it. If a component may be subject to interference, be sure to protect it with a shop cloth.
- When removing (disengaging) components with a screwdriver or similar tool, be sure to wrap the component with a shop cloth or vinyl tape to protect it.
- Protect the removed parts with a shop cloth and prevent them from being dropped.
- Replace a deformed or damaged clip.
- If a part is specified as a non-reusable part, always replace it with a new one.
- Be sure to tighten bolts and nuts securely to the specified torque.
- After installation is complete, be sure to check that each part works properly.
- Follow the steps below to clean components:
 - Water soluble dirt:
 - Dip a soft cloth into lukewarm water, wring the water out of the cloth and wipe the dirty area.
 - Then rub with a soft, dry cloth.
 - Oily dirt:
 - Dip a soft cloth into lukewarm water with mild detergent (concentration: within 2 to 3%) and wipe the dirty area.
 - Then dip a cloth into fresh water, wring the water out of the cloth and wipe the detergent off.
 - Then rub with a soft, dry cloth.
 - Do not use organic solvent such as thinner, benzene, alcohol or gasoline.
 - For genuine leather seats, use a genuine leather seat cleaner.

PREPARATION

< PREPARATION >

PREPARATION

PREPARATION

Special Service Tool

INFOID:000000007328527

The actual shapes of Kent-Moore tools may differ from those of special service tools illustrated here.

Tool number (Kent-Moore No.) Tool name	Description
— (J-39570) Chassis ear	Locating the noise
— (J-43980) NISSAN Squeak and Rattle Kit	Repairing the cause of noise
— (J-46534) Trim Tool Set	Removing trim components

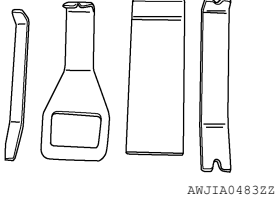
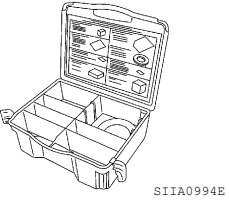
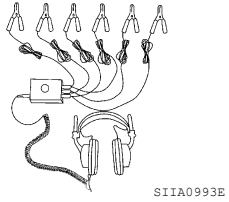

Commercial Service Tool

INFOID:000000007328528

(Kent-Moore No.) Tool name	Description
(J-39565) Engine ear	Locating the noise

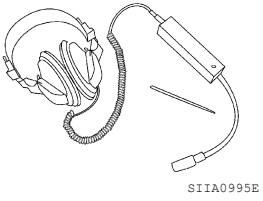

CLIP LIST







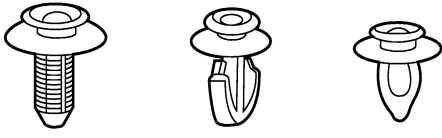

< PREPARATION >

CLIP LIST

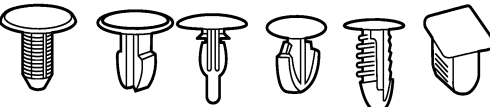
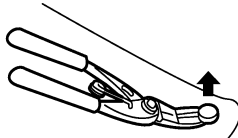
Descriptions for Clips

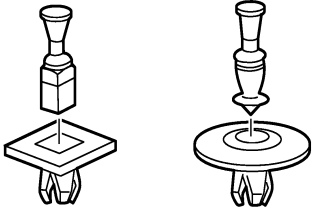
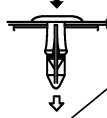
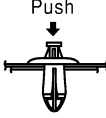
INFOID:000000007831504

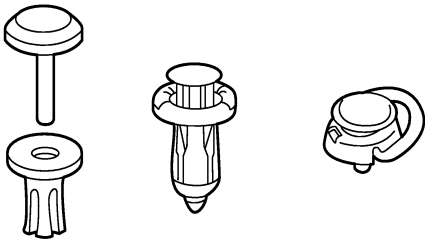
Replace any clips which are damaged during removal or installation.

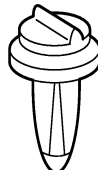
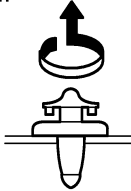





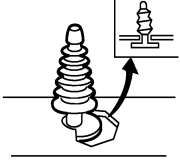
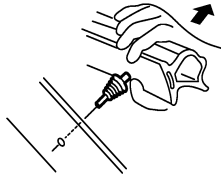

Symbol No.	Shapes	Removal & Installation
C101 		<p>Removal: Remove by bending up with flat-bladed screwdrivers or clip remover.</p> 
C103 		 <p>Removal: Remove with a clip remover.</p>
C203 		<p>Removal: Push center pin to catching position. (Do not remove center pin by hitting it.)</p> <p>Push</p>  <p>Installation:</p> <p>Push</p> 
C205 		<p>Removal: Flat-bladed screwdriver</p>  <p>Clip</p> <p>Finisher</p>
C206 		<p>Removal:</p> 

SIIA0315E

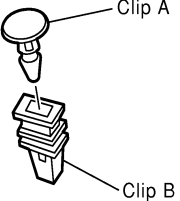
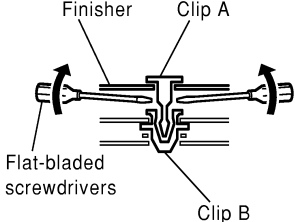
A
B
C
D
E
F
G
H
I
SE
K
L
M
N
O
P

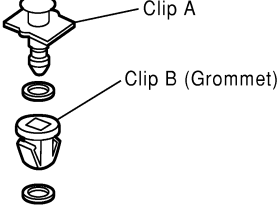
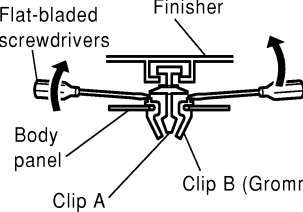
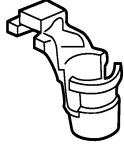
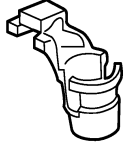
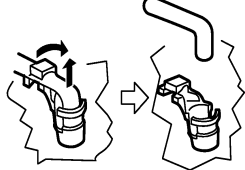
CLIP LIST

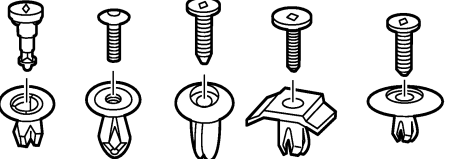









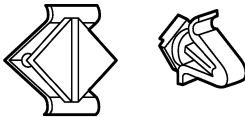

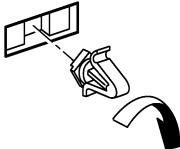
< PREPARATION >

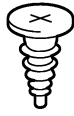
Symbol No.	Shapes	Removal & Installation
<p>CE103</p> 		<p>Removal:</p> 
<p>CF110</p> 		<p>Removal:</p> 
<p>CF118</p> 		<p>Removal:</p> 
<p>CR103</p> 		<p>Removal: Holder portion of clip must be spread out to remove rod.</p> 
<p>CS101</p> 		<p>Removal:</p> <ol style="list-style-type: none"> 1. Screw out with a Phillips screwdriver. 2. Remove female portion with flat-bladed screwdriver. 

SIIA0316E

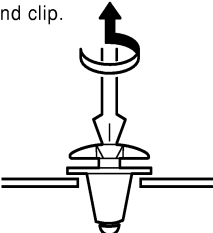
CLIP LIST

< PREPARATION >





Symbol No.	Shapes	Removal & Installation	
CG101 		Removal:  Rotate 45° to remove	Installation: 
CS102 			
CS113 		Removal: Disconnect upper connection of clip with a flat-bladed screwdriver, then remove clip while inserting a flat-bladed screwdriver between body panel and clip. 	
C111 			

SIIA0317E

A
B
C
D
E
F
G
H
I
SE
K
L
M
N
O
P

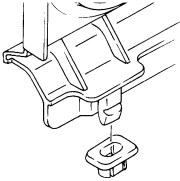
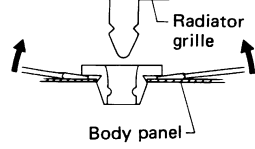
CLIP LIST

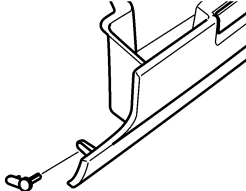
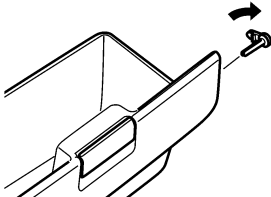
< PREPARATION >

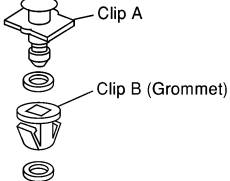
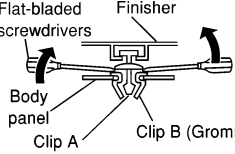
Symbol No.	Shapes	Removal & Installation
<p>CG104</p> 		<p>Removal: Remove by bending up with flat-bladed screwdrivers.</p>  <p>Radiator grille Body panel</p>
<p>CE114</p> 		
<p>CF118</p> 	 <p>Clip A Clip B (Grommet)</p>	<p>Removal: Flat-bladed screwdrivers Finisher</p>  <p>Body panel Clip A Clip B (Grommet)</p>

ALJIA0564GB

FRONT SEAT

< REMOVAL AND INSTALLATION >

REMOVAL AND INSTALLATION

FRONT SEAT

Component

INFOID:000000007328529

Power Driver Seat

SEC. 870

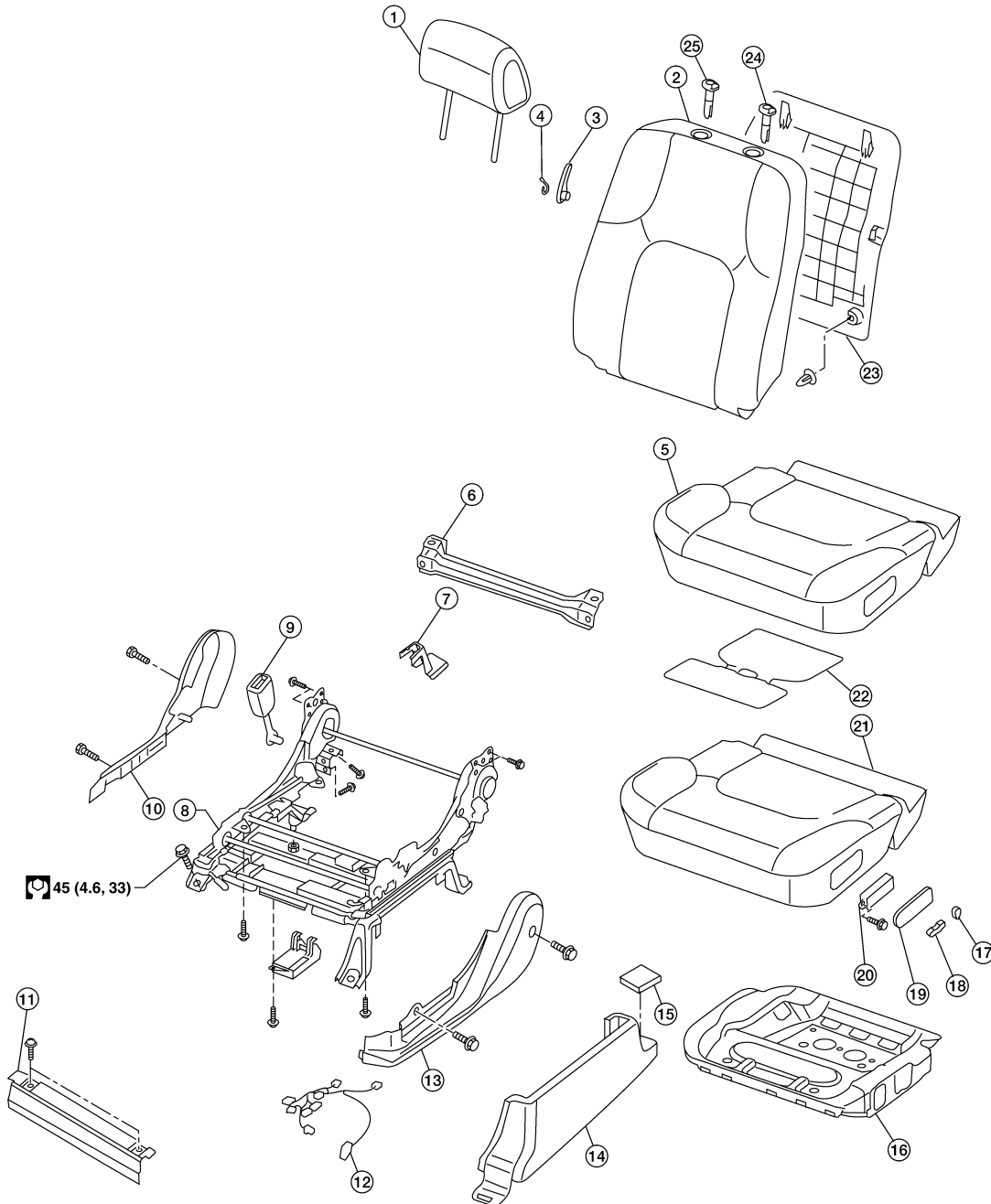

A
B
C
D
E
F
G
H
I
SE
K
L
M
N
O
P

AWJIA0466GB

FRONT SEAT

< REMOVAL AND INSTALLATION >

- | | | |
|----------------------------------|----------------------------------|--|
| 1. Headrest | 2. Seatback assembly | 3. Lumbar support lever knob |
| 4. Snap ring | 5. Seat cushion trim | 6. Power seat cushion rear finisher |
| 7. Leg Cover | 8. Seat frame assembly | 9. Seat belt buckle assembly |
| 10. Seat cushion inner finisher | 11. Seat cushion front finisher | 12. Driver seat wiring harness |
| 13. Seat cushion outer finisher | 14. Leg cover | 15. Bolt cover |
| 16. Seat cushion frame | 17. Recliner switch knob | 18. Slide switch knob |
| 19. Power seat switch escutcheon | 20. Switch assembly | 21. Seat cushion pad |
| 22. Seat cushion heating element | 23. Seatback board (if equipped) | 24. Headrest holder with multi position lock |
| 25. Headrest holder | | |

FRONT SEAT

< REMOVAL AND INSTALLATION >

Manual Driver Seat

SEC. 870

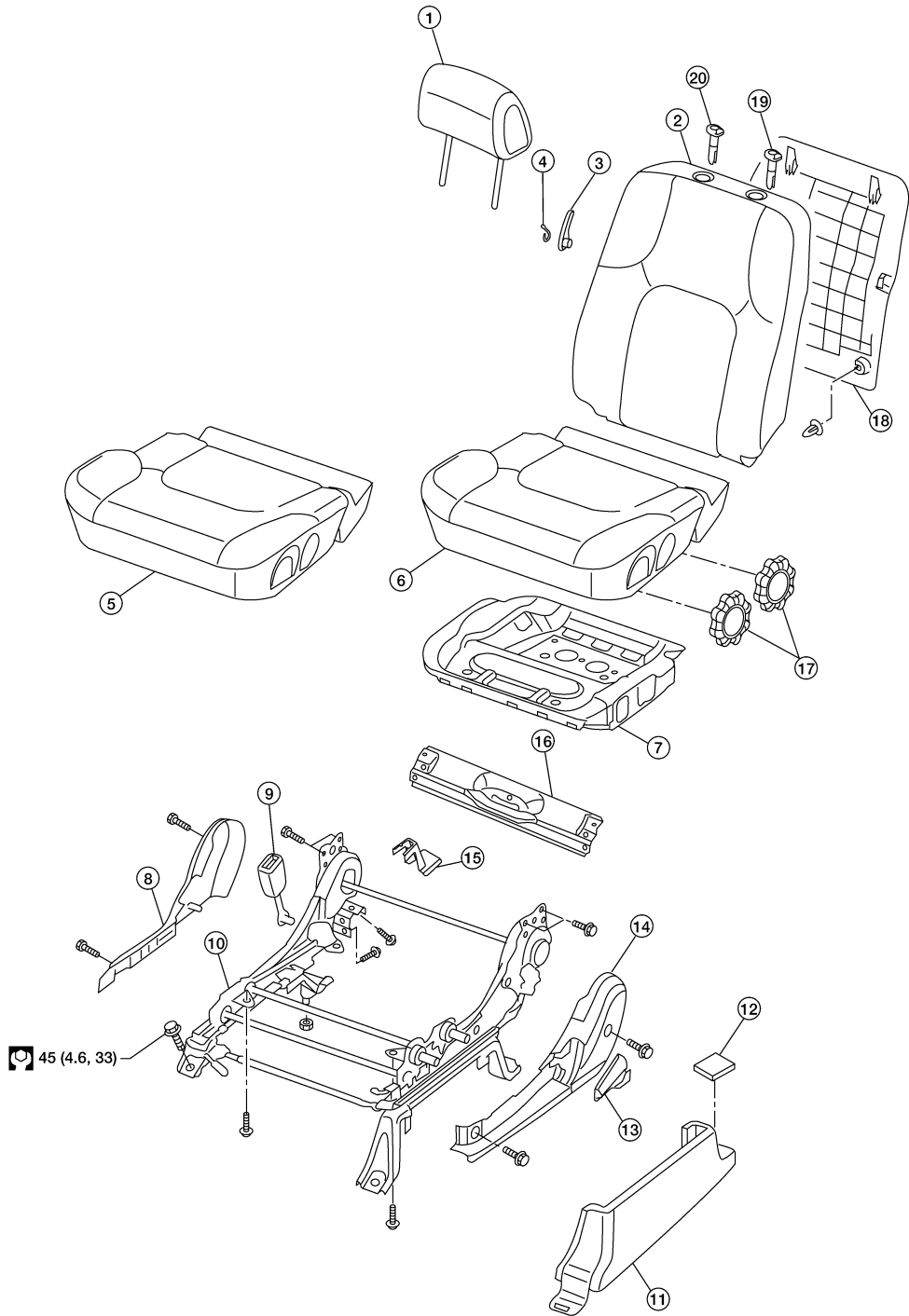

AWJIA0467GB

- | | | |
|-------------------------|---------------------------------|------------------------------|
| 1. Headrest | 2. Seatback assembly | 3. Lumbar support lever knob |
| 4. Snap ring | 5. Seat cushion trim cover | 6. Seat cushion pad |
| 7. Seat cushion frame | 8. Seat cushion inner finisher | 9. Seat belt buckle assembly |
| 10. Seat frame assembly | 11. Leg cover | 12. Bolt cover |
| 13. Recline lever | 14. Seat cushion outer finisher | 15. Leg cover |

A
B
C
D
E
F
G
H
I
SE
K
L
M
N
O
P

FRONT SEAT

< REMOVAL AND INSTALLATION >

- | | | |
|--|-----------------------------|--------------------|
| 16. Seat cushion rear finisher | 17. Seat cushion lift knobs | 18. Seatback board |
| 19. Headrest holder with multi position lock | 20. Headrest holder | |

Conventional Passenger Seat

SEC. 870

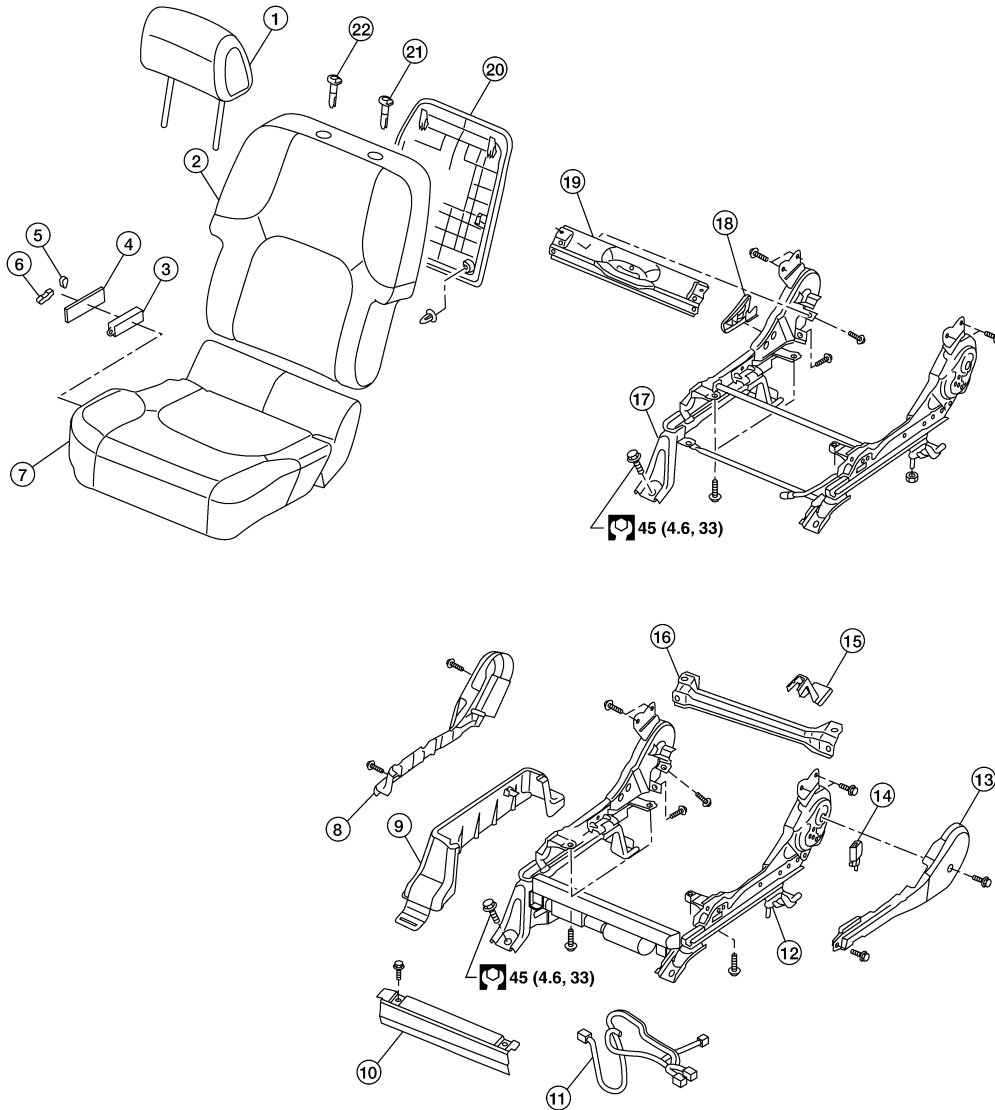

- | | | |
|---------------------------------|--|----------------------|
| 1. Headrest | 2. Seatback assembly with side air bag | 3. Switch assembly |
| 4. Power seat switch escutcheon | 5. Recliner switch knob | 6. Slide switch knob |
| 7. Seat cushion assembly | 8. Seat cushion outer cover | 9. Leg cover |

ANJIA0468GB

FRONT SEAT

< REMOVAL AND INSTALLATION >

- | | | |
|---------------------------------|-----------------------------------|--|
| 10. Seat cushion front finisher | 11. Passenger seat wiring harness | 12. Power seat frame assembly |
| 13. Seat cushion inner finisher | 14. Seat belt buckle assembly | 15. Leg cover |
| 16. Seat cushion rear finisher | 17. Manual seat frame assembly | 18. Recline lever |
| 19. Seat cushion rear finisher | 20. Seatback board | 21. Headrest holder with multi position lock |
| 22. Headrest holder | | |

Fold Flat Passenger Seat

SEC. 870

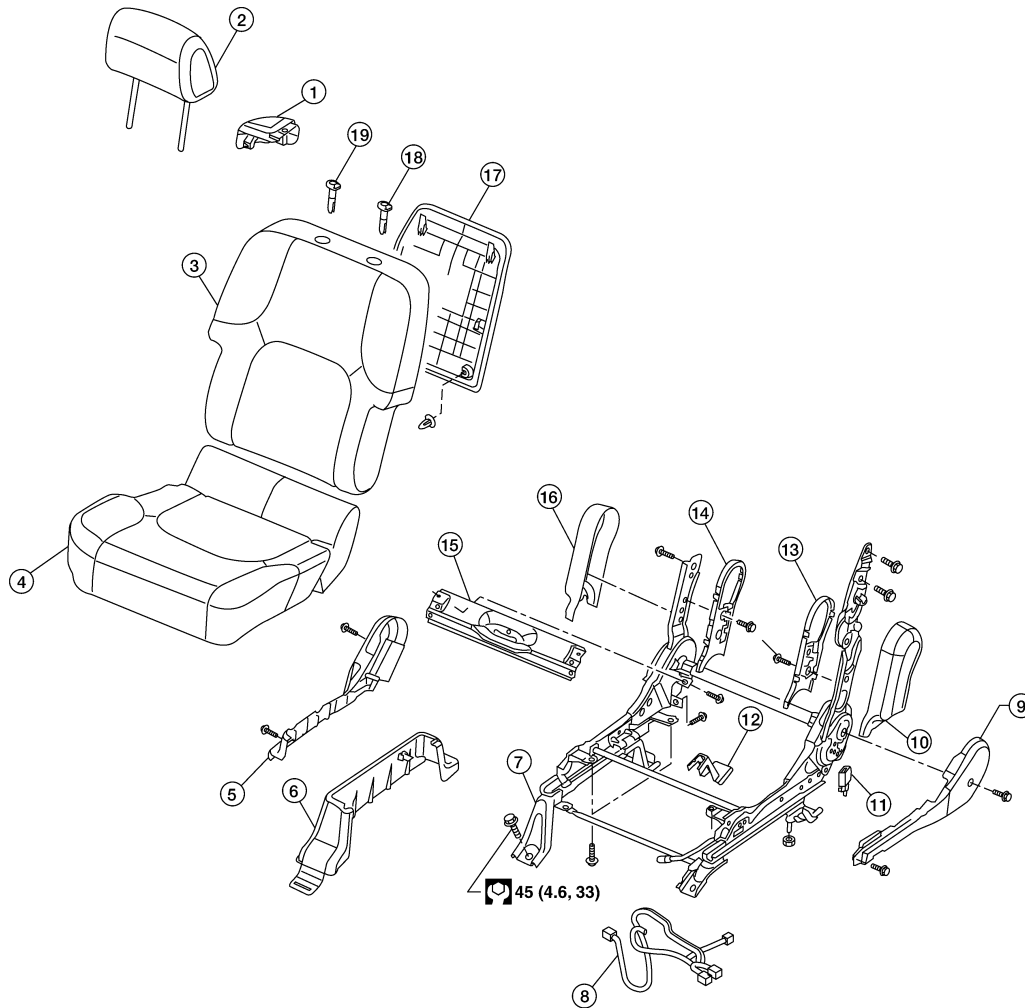

A
B
C
D
E
F
G
H
I
SE
K
L
M
N
O
P

AWJIA0469GB

FRONT SEAT

< REMOVAL AND INSTALLATION >

- | | | |
|--|--|--|
| 1. Front seatback lever | 2. Headrest | 3. Seatback assembly |
| 4. Seat cushion assembly | 5. Seat cushion outer finisher | 6. Leg cover |
| 7. Seat frame assembly | 8. Passenger seat wiring harness | 9. Seat cushion inner cover |
| 10. Inboard reclining arm outer cover | 11. Seat belt buckle assembly | 12. Leg cover |
| 13. Inboard reclining arm inner cover | 14. Outboard reclining arm inner cover | 15. Seat cushion rear finisher |
| 16. Outboard reclining arm outer cover | 17. Seatback board | 18. Headrest holder with multi position lock |
| 19. Headrest holder | | |

Removal and Installation

INFOID:000000007328530

REMOVAL

When removing or installing the seat trim, handle it carefully to keep dirt out and avoid damage.

CAUTION:

- **Before removing the front seat, turn the ignition switch off, disconnect both battery terminals and wait at least 3 minutes.**
- **When checking the power seat circuit for continuity using a circuit tester, do not confuse its connector with the side air bag module connector. Such an error may cause the air bag to deploy.**
- **Do not drop, tilt, or bump the side air bag module while installing the seat. Always handle it with care.**
- **After front side air bag module inflates, front seatback assembly must be replaced.**
- **Front passenger seat is equipped with an Occupant Classification System sensor and control module. Do not disassemble front passenger seat cushion assembly or remove the trim as this will affect the Occupant Classification System calibration.**
- **Always replace passenger seat cushion as an assembly.**

1. Slide the seat until the four mount bolts are visible and a suitable tool can be inserted.

NOTE:

Set the front/rear cushion lifters to the top position.

2. Disconnect both battery terminals and wait at least 3 minutes.
3. Disconnect the side air bag module harness connector.
4. Remove the leg covers.
5. Remove the four front seat bolts.
6. Disconnect the power seat harness connectors and remove the seat from the vehicle.

NOTE:

When removing and installing the seat, use shop cloths to protect the vehicle from damage.

INSTALLATION

Installation is in the reverse order of removal.

REAR SEAT

< REMOVAL AND INSTALLATION >

REAR SEAT

Removal and Installation

INFOID:000000007328531

JUMP SEAT (KING CAB)

Removal

1. Remove seat base trim panel.

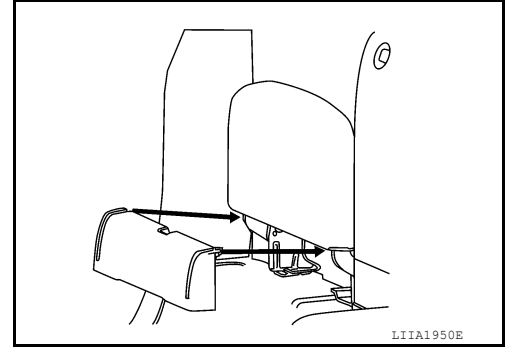

2. Remove the seat cushion bolts and assembly.

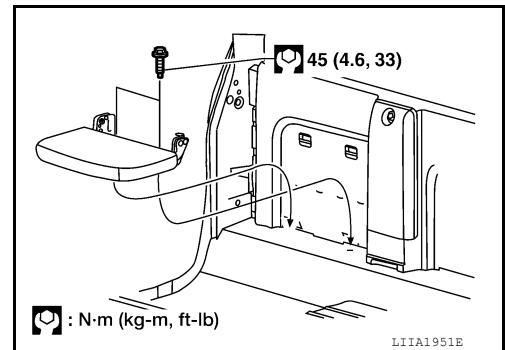

3. Remove the bolt, lift and remove the seatback assembly.

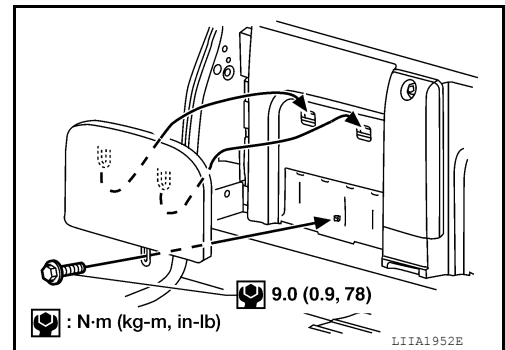

Installation

Installation is in the reverse order of removal.

BENCH SEAT LH (CREW CAB)

Removal

1. Remove the seat hinge finishers.

A
B
C
D
E
F
G
H
I
SE
K
L
M
N
O
P

REAR SEAT

< REMOVAL AND INSTALLATION >

2. Release the seatback latch and tilt the seatback down. Remove the nuts.

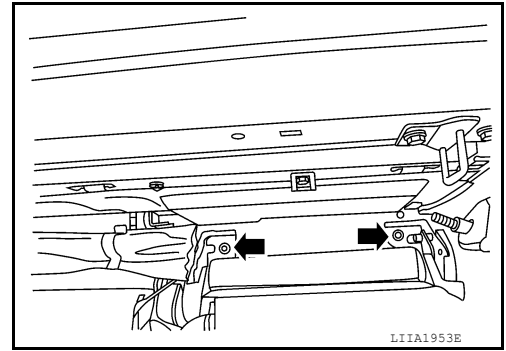

3. Raise the seatback.
4. Tilt the seat cushion up.
5. Remove the seat bolts.
6. Remove the seat.

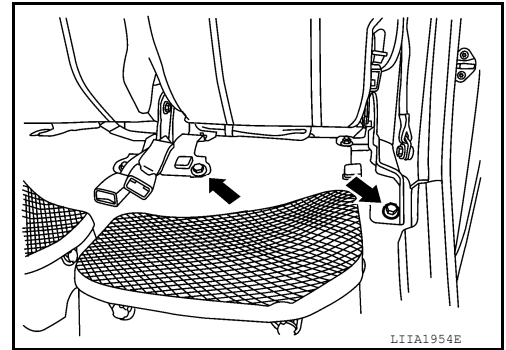

Installation

Installation is in the reverse order of removal.

NOTE:

Make sure the washers are on the rear studs prior to seat assembly installation.

Seat nuts : 45 N·m (4.6 kg-m, 33 ft-lb)

Seat bolts : 45 N·m (4.6 kg-m, 33 ft-lb)

BENCH SEAT RH (CREW CAB)

Removal

1. Remove the seat hinge finishers.
2. Release the seatback latch and tilt the seatback down. Remove the nuts.

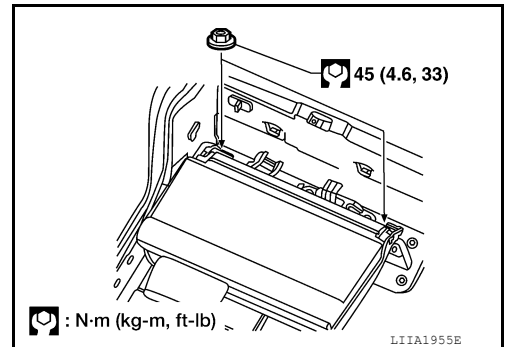

3. Raise the seatback.

REAR SEAT

< REMOVAL AND INSTALLATION >

4. Remove the seat belt buckle from the cushion.
5. Remove the seat bolts.
6. Remove the seat assembly.

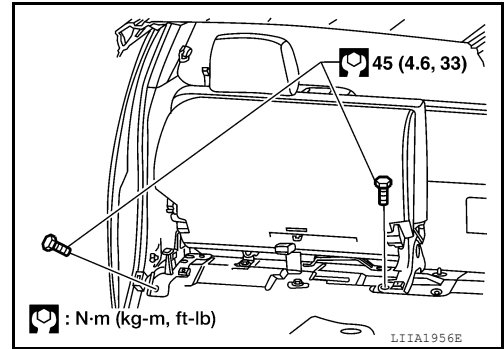

Installation

Installation is in the reverse order of removal.

NOTE:

Make sure the washers are on the rear studs prior to seat assembly installation.

A
B
C
D
E
F
G
H
I
K
L
M
N
O
P

SE

FRONT SEAT

< UNIT DISASSEMBLY AND ASSEMBLY >

UNIT DISASSEMBLY AND ASSEMBLY

FRONT SEAT

Component

INFOID:000000007328532

Power Driver Seat

SEC. 870

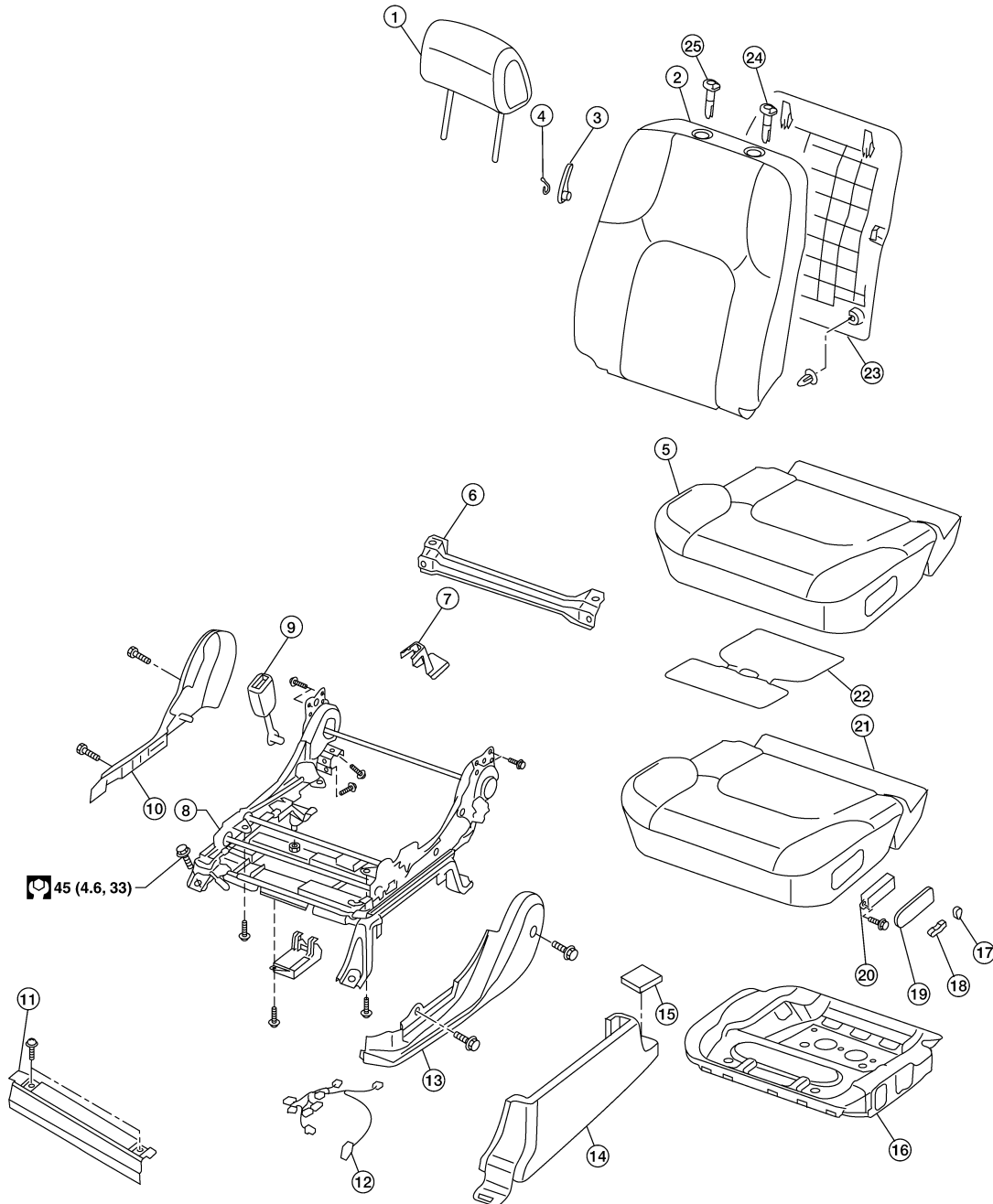

AWJIA0466GB

FRONT SEAT

< UNIT DISASSEMBLY AND ASSEMBLY >

1. Headrest	2. Seatback assembly	3. Lumbar support lever knob	A
4. Snap ring	5. Seat cushion trim	6. Power seat cushion rear finisher	
7. Leg Cover	8. Seat frame assembly	9. Seat belt buckle assembly	
10. Seat cushion inner finisher	11. Seat cushion front finisher	12. Driver seat wiring harness	B
13. Seat cushion outer finisher	14. Leg cover	15. Bolt cover	
16. Seat cushion frame	17. Recliner switch knob	18. Slide switch knob	
19. Power seat switch escutcheon	20. Switch assembly	21. Seat cushion pad	C
22. Seat cushion heating element	23. Seatback board (if equipped)	24. Headrest holder with multi position lock	
25. Headrest holder			D
			E
			F
			G
			H
			I
			SE
			K
			L
			M
			N
			O
			P

FRONT SEAT

< UNIT DISASSEMBLY AND ASSEMBLY >

Manual Driver Seat

SEC. 870

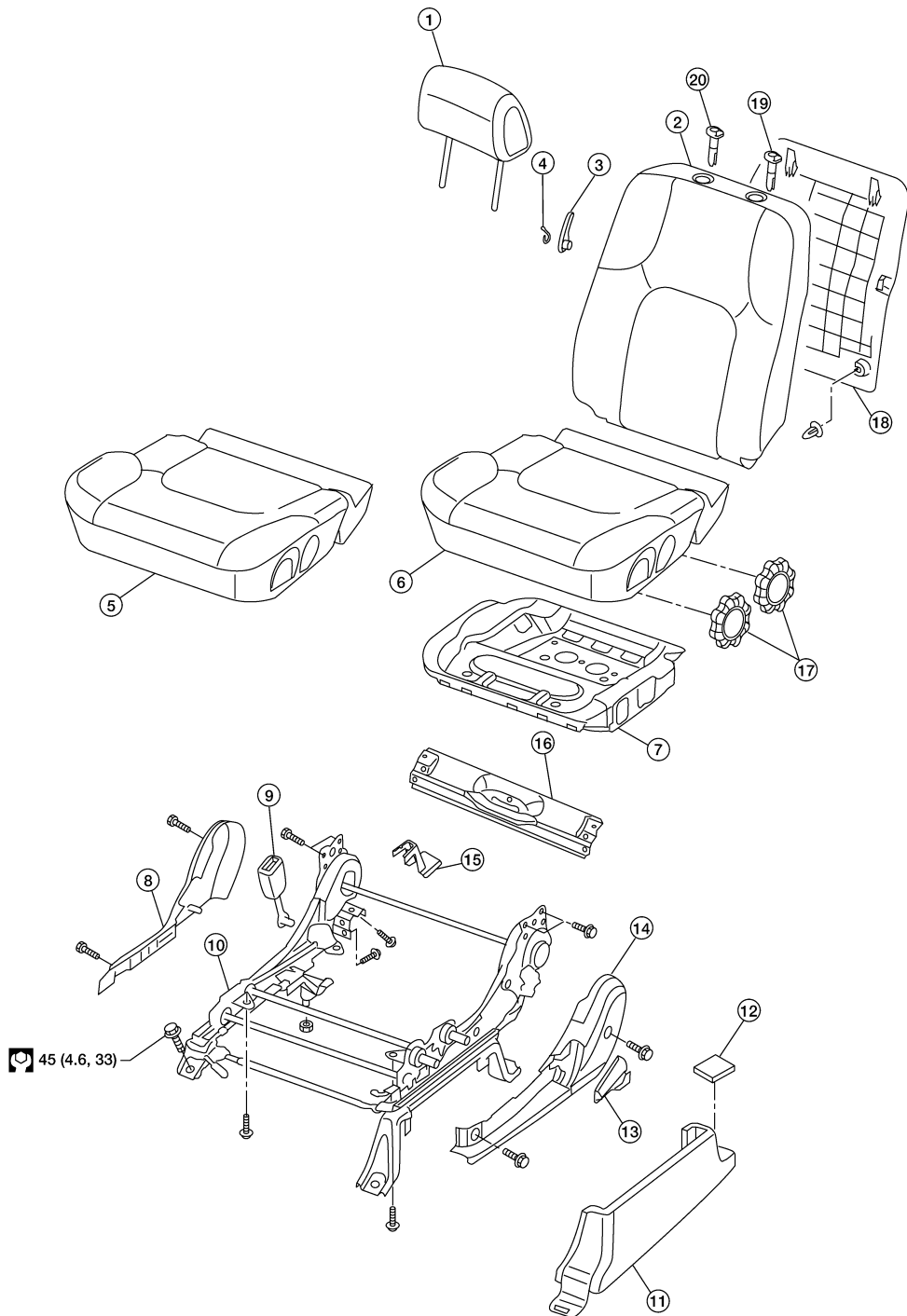

AWJIA0467GB

- | | | |
|-------------------------|---------------------------------|------------------------------|
| 1. Headrest | 2. Seatback assembly | 3. Lumbar support lever knob |
| 4. Snap ring | 5. Seat cushion trim cover | 6. Seat cushion pad |
| 7. Seat cushion frame | 8. Seat cushion inner finisher | 9. Seat belt buckle assembly |
| 10. Seat frame assembly | 11. Leg cover | 12. Bolt cover |
| 13. Recline lever | 14. Seat cushion outer finisher | 15. Leg cover |

FRONT SEAT

< UNIT DISASSEMBLY AND ASSEMBLY >

- | | | |
|--|-----------------------------|--------------------|
| 16. Seat cushion rear finisher | 17. Seat cushion lift knobs | 18. Seatback board |
| 19. Headrest holder with multi position lock | 20. Headrest holder | |

Conventional Passenger Seat

SEC. 870

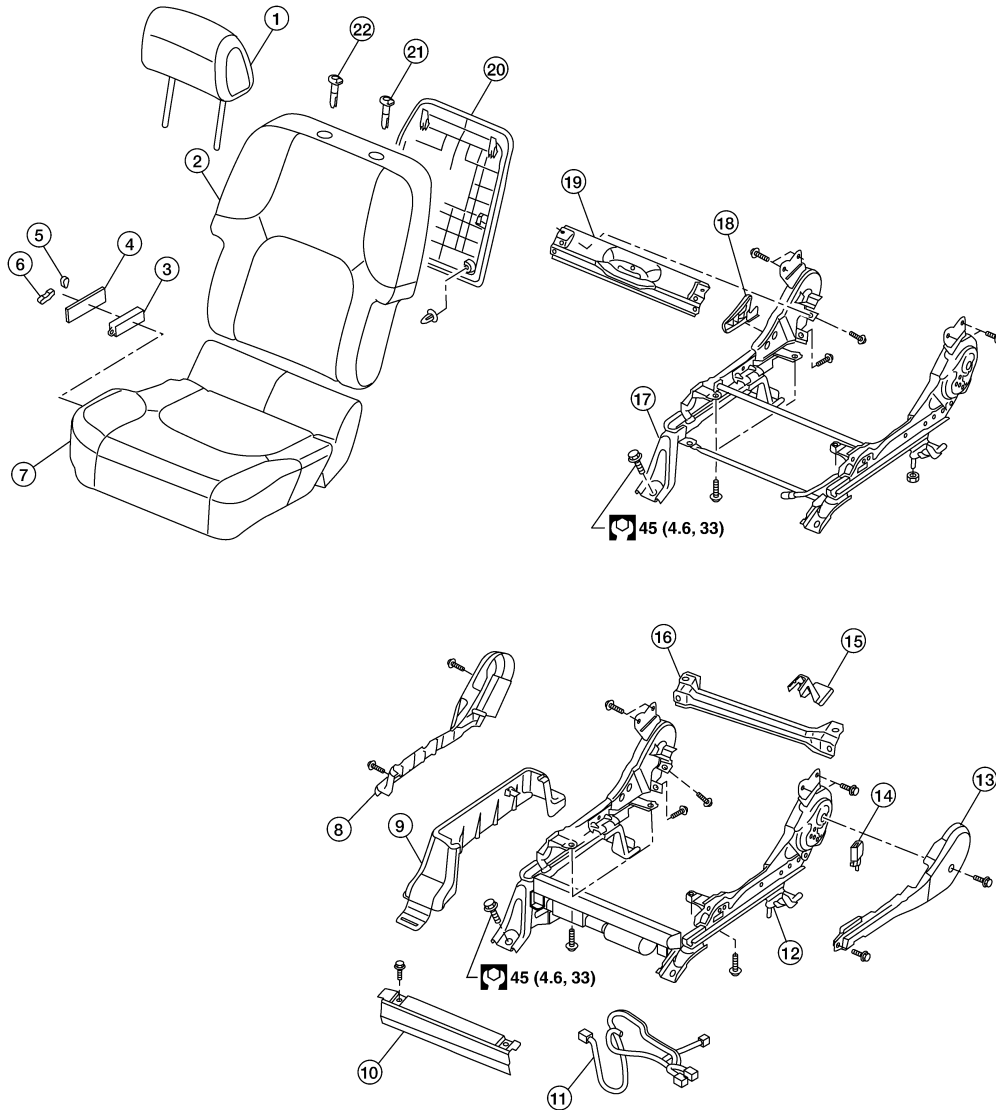

A
B
C
D
E
F
G
H
I
SE
K
L
M
N
O
P

- | | | |
|---------------------------------|--|----------------------|
| 1. Headrest | 2. Seatback assembly with side air bag | 3. Switch assembly |
| 4. Power seat switch escutcheon | 5. Recliner switch knob | 6. Slide switch knob |
| 7. Seat cushion assembly | 8. Seat cushion outer cover | 9. Leg cover |

AWJIA0468GB

FRONT SEAT

< UNIT DISASSEMBLY AND ASSEMBLY >

- | | | |
|---------------------------------|-----------------------------------|--|
| 10. Seat cushion front finisher | 11. Passenger seat wiring harness | 12. Power seat frame assembly |
| 13. Seat cushion inner finisher | 14. Seat belt buckle assembly | 15. Leg cover |
| 16. Seat cushion rear finisher | 17. Manual seat frame assembly | 18. Recline lever |
| 19. Seat cushion rear finisher | 20. Seatback board | 21. Headrest holder with multi position lock |
| 22. Headrest holder | | |

Fold Flat Passenger Seat

SEC. 870

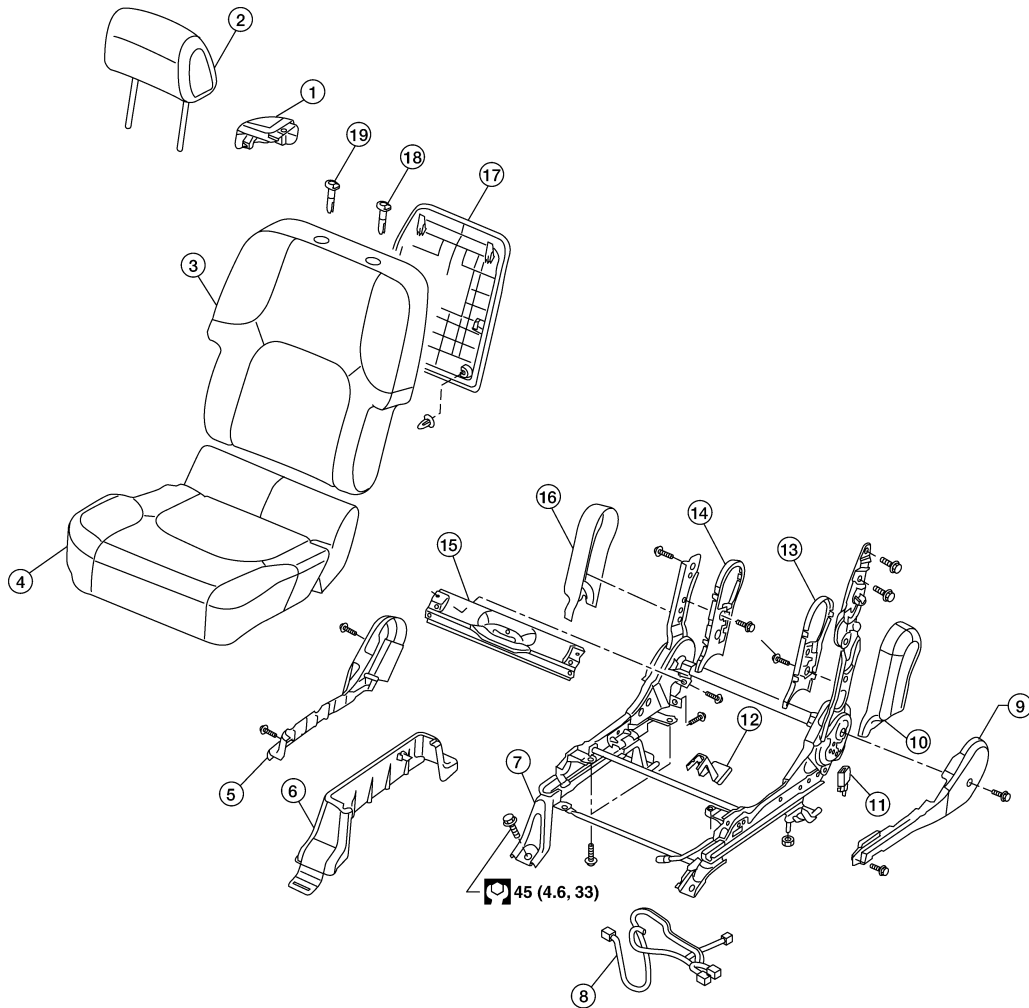

FRONT SEAT

< UNIT DISASSEMBLY AND ASSEMBLY >

- | | | | |
|--|--|--|---|
| 1. Front seatback lever | 2. Headrest | 3. Seatback assembly | A |
| 4. Seat cushion assembly | 5. Seat cushion outer finisher | 6. Leg cover | B |
| 7. Seat frame assembly | 8. Passenger seat wiring harness | 9. Seat cushion inner cover | B |
| 10. Inboard reclining arm outer cover | 11. Seat belt buckle assembly | 12. Leg cover | B |
| 13. Inboard reclining arm inner cover | 14. Outboard reclining arm inner cover | 15. Seat cushion rear finisher | C |
| 16. Outboard reclining arm outer cover | 17. Seatback board | 18. Headrest holder with multi position lock | C |
| 19. Headrest holder | | | D |

Seatback Assembly

INFOID:000000007328533

REMOVAL

NOTE:

On vehicles equipped with side air bags, only complete seatback assemblies can be replaced.

1. Remove the seatback board from the back of the seatback.
2. Remove the retainer.

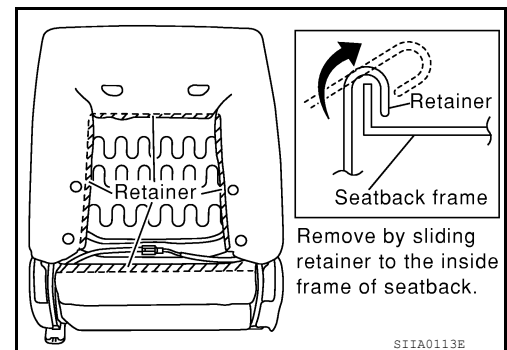

3. Disconnect the seatback heater harness.
4. Remove the seatback bolts (2 for each side) and seatback assembly.

SEATBACK BOARD - SOFT SEATBACK

Removal

1. The seatback board is attached to the seat frame with the following:
 - Two top tabs (A)
 - Two side tabs (B)
 - Two bottom clips (C) (must be replaced)
2. Move seat to forward position.

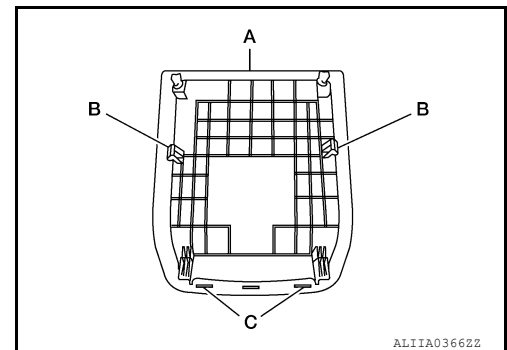

3. Hold the seatback board as shown and pull the top of the seatback board down and away from the seat back frame.

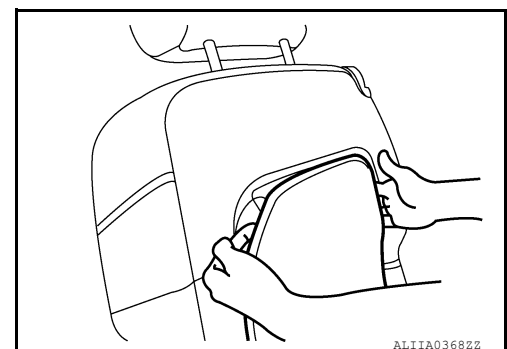

FRONT SEAT

< UNIT DISASSEMBLY AND ASSEMBLY >

4. Pull the middle part of the seatback board to disengage the side tabs from the seatback frame.
5. Pull the lower part of the seatback board to disengage the bottom clips from the seatback frame.

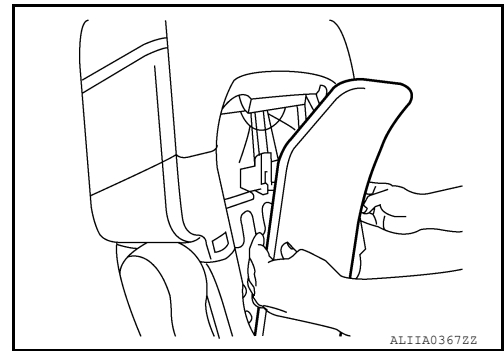

Installation

Installation is in the reverse order of removal.

- The two bottom clips must be replaced for installation
- Secure the side tabs last for installation

SEATBACK BOARD - HARD SEATBACK

Removal

1. Remove the seatback assembly. Refer to [SE-32. "Removal and Installation"](#).
2. The seatback board is attached to the seat frame with the following:
 - Two top tabs (A)
 - Two side tabs (B)
 - Two bottom clips (C) (must be replaced)
3. Move seat to forward position.

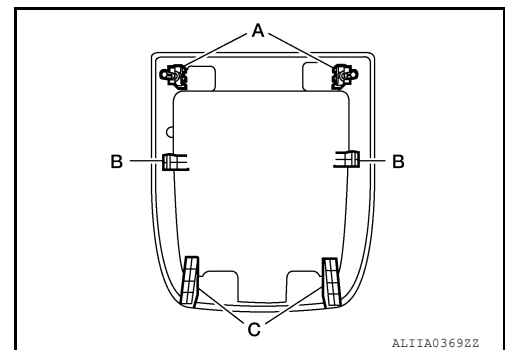

4. Hold the seatback board as shown and pull the bottom of the seatback board away from the seat back frame.

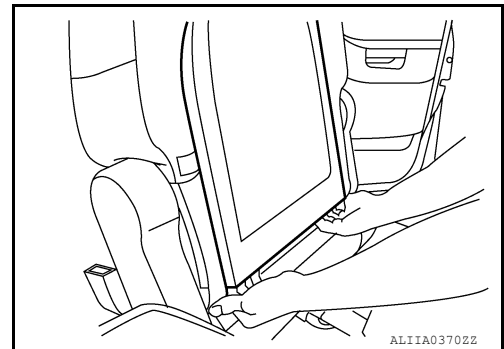

5. Pull the middle part of the seatback board up and away to disengage the side tabs from the seatback frame.

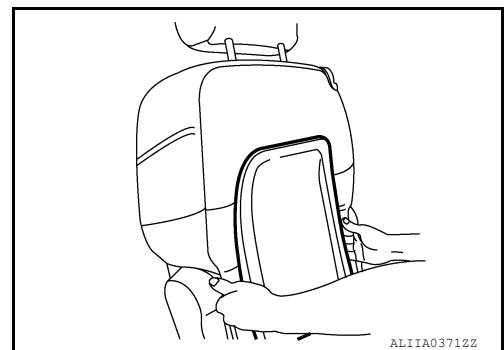

FRONT SEAT

< UNIT DISASSEMBLY AND ASSEMBLY >

6. Lift the upper part of the seatback board to disengage the top tabs from the seatback frame.

Installation

Installation is in the reverse order of removal.

- The two bottom clips must be replaced for installation
- Secure the side tabs last for installation

INSTALLATION

Installation is in the reverse order of removal.

Seat Cushion Trim and Pad

INFOID:000000007328534

REMOVAL

CAUTION:

- Front passenger seat is equipped with an Occupant Classification System sensor and control module. Do not disassemble front passenger seat cushion assembly or remove the trim as this will affect the Occupant Classification System calibration.
 - Always replace passenger seat cushion as an assembly.
 - When removed, the passenger seat cushion must always be placed pan side UP to prevent damage.
 - During installation, the wire harness clips must be reinstalled in the holes they were originally in. Do not add additional clips.
 - The Occupant Classification System control module can only be replaced as part of the seat cushion assembly.
1. Remove the front seat assembly. Refer to [SE-32, "Removal and Installation"](#).
 2. Remove the power seat switch knobs and power seat switch escutcheon (if equipped) (or lift knobs on manual seats).

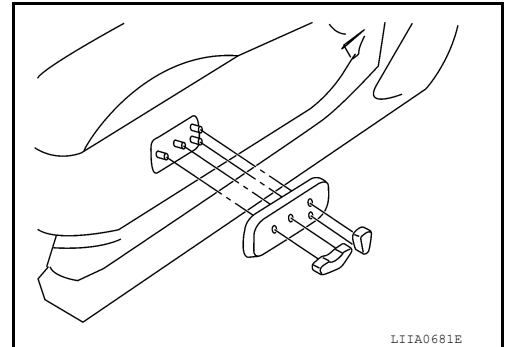

3. Remove the seat cushion outer finisher.

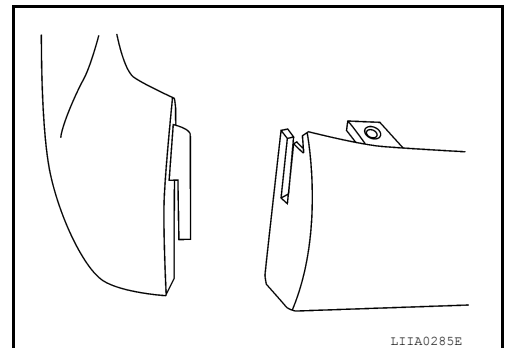

4. Remove the power seat switch screws.
5. Remove four bolts and the seat cushion assembly.

A
B
C
D
E
F
G
H
I
SE
K
L
M
N
O
P

FRONT SEAT

< UNIT DISASSEMBLY AND ASSEMBLY >

- On the fold flat passenger seat it is necessary to unclip the rear flap j-clip from the seat pan.

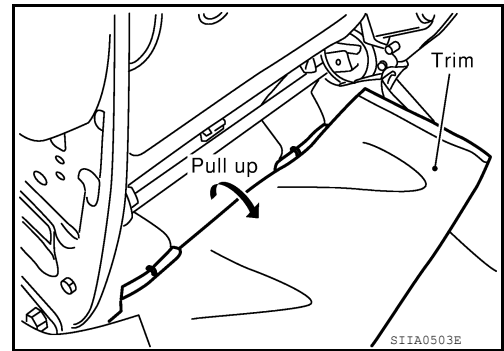

6. Remove the retainer on the seat cushion frame, then remove the harness connector for the seat cushion heater (if equipped).

DISASSEMBLY

CAUTION:

- **Front passenger seat is equipped with an Occupant Classification System sensor and control module. Do not disassemble front passenger seat cushion assembly or remove the trim as this will affect the Occupant Classification System calibration.**

1. Remove the seat cushion assembly.
2. On the drivers seat only, remove the hog rings to separate the trim cover from the pad and seat cushion heater unit.

ASSEMBLY

Assembly is in the reverse order of disassembly.

INSTALLATION

Installation is in the reverse order of removal.

REAR SEAT

< UNIT DISASSEMBLY AND ASSEMBLY >

REAR SEAT

Disassembly and Assembly

INFOID:000000007328535

Jump Seat (King Cab)

SEC. 880

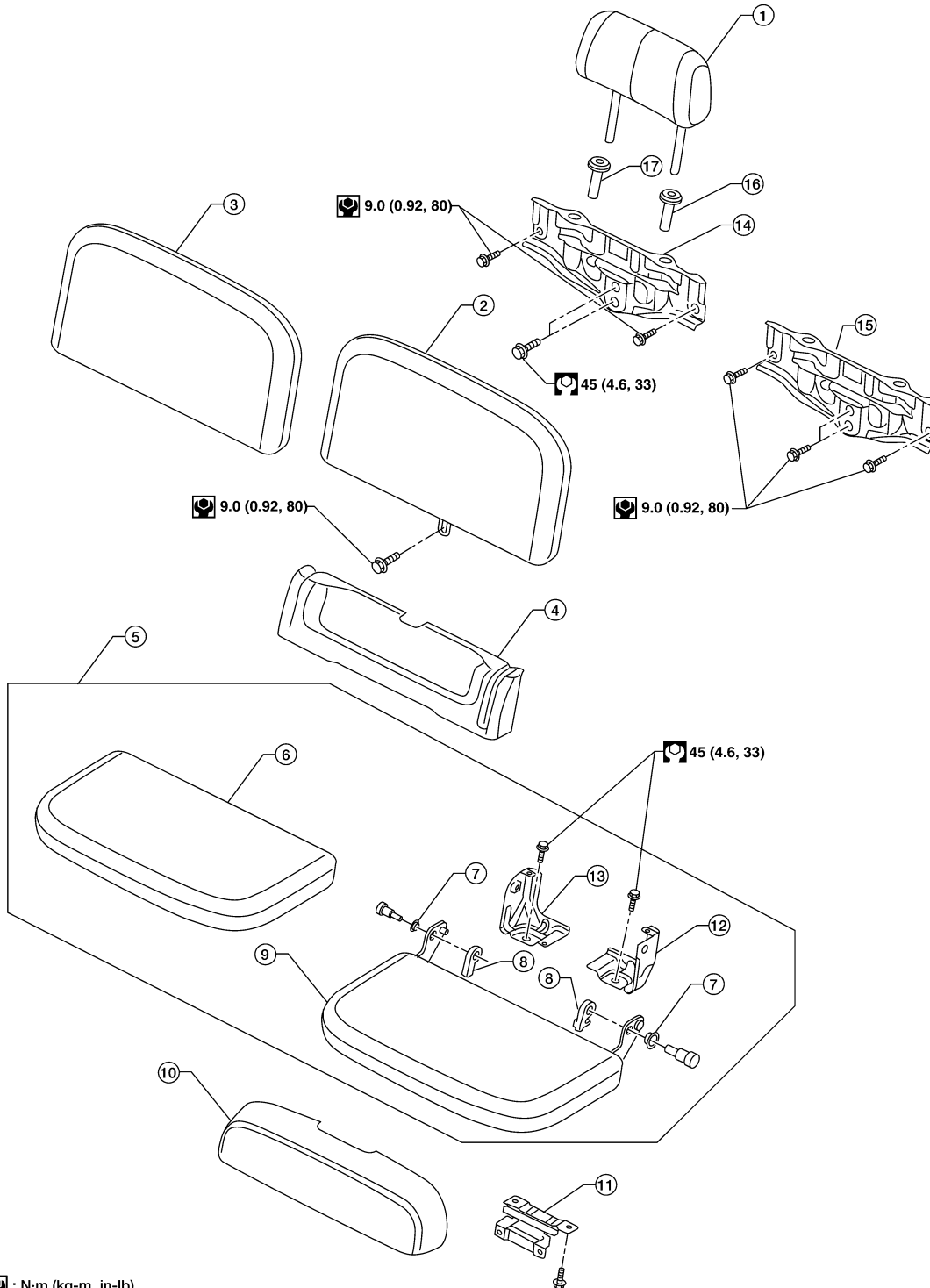

: N·m (kg·m, in·lb)
 : N·m (kg·m, ft·lb)

- | | | |
|-------------------------|---------------------------|-------------------------------|
| 1. Headrest | 2. Seatback pad and frame | 3. Seatback trim cover |
| 4. Seat base trim panel | 5. Seat cushion assembly | 6. Seat cushion trim cover |
| 7. Bushing | 8. Spacer | 9. Seat cushion pad and frame |

LI1A1957E

A
B
C
D
E
F
G
H
I
SE
K
L
M
N
O
P

REAR SEAT

< UNIT DISASSEMBLY AND ASSEMBLY >

- | | | |
|--|--------------------------------|-----------------------------------|
| 10. Child seat extension (Passenger side only) | 11. Child seat extension hinge | 12. Inboard jump seat pivot riser |
| 13. Outboard jump seat pivot riser | 14. RH headrest plate | 15. LH headrest plate |
| 16. Inboard headrest locking guide | 17. Outboard headrest guide | |

Bench Seat LH (Crew Cab)

SEC. 880

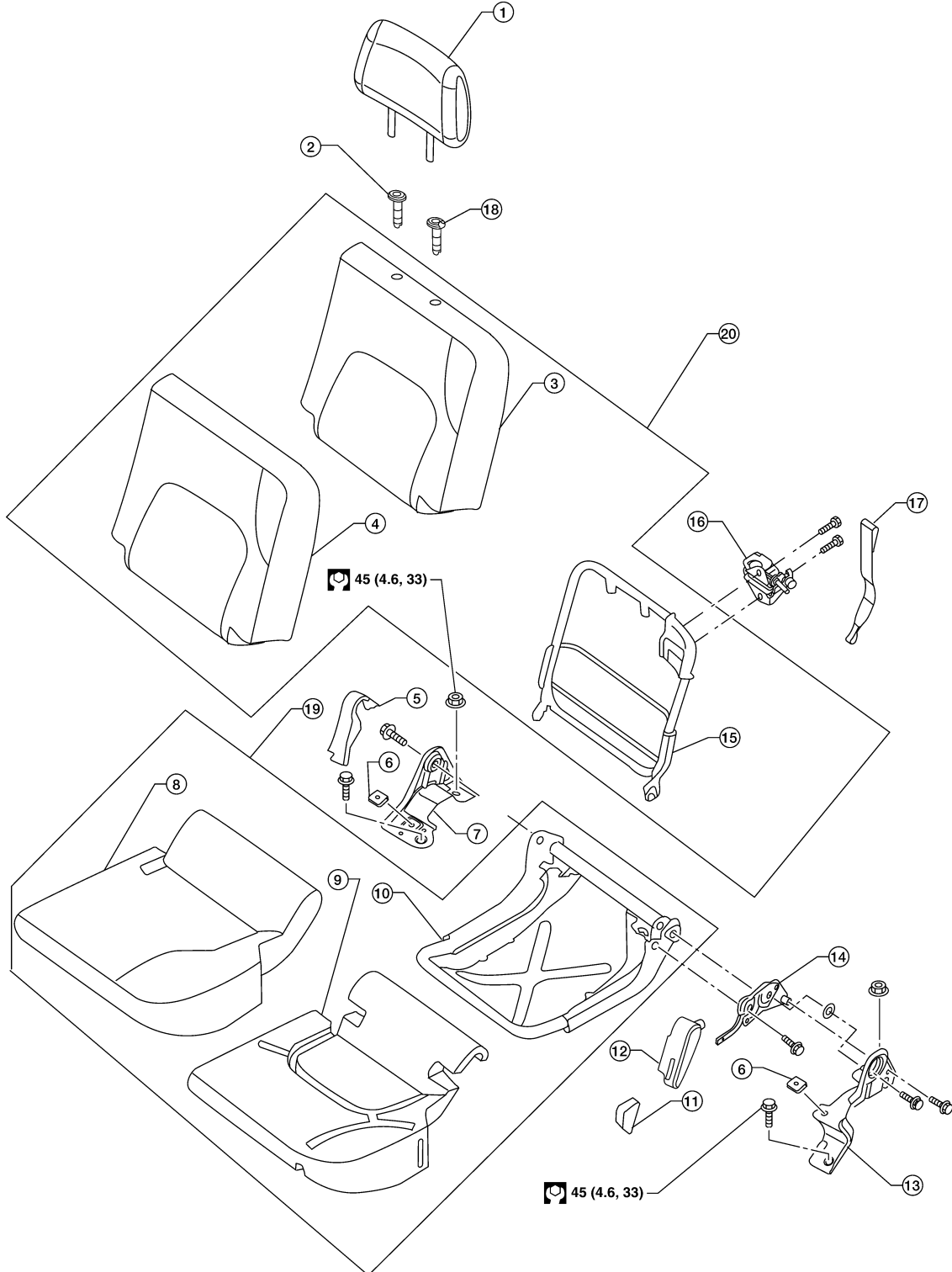

W11A1059E

- | | | |
|------------------------|---------------------------|------------------------------|
| 1. Headrest | 2. Inboard headrest guide | 3. Seatback pad |
| 4. Seatback trim cover | 5. Inboard pivot cover | 6. Seat cushion bumper RH/LH |

REAR SEAT

< UNIT DISASSEMBLY AND ASSEMBLY >

- | | | |
|---------------------------------------|---------------------------------------|-------------------------------------|
| 7. Inboard seat cushion pivot riser | 8. Seat cushion trim cover | 9. Seat cushion pad |
| 10. Seat cushion pan | 11. Seat cushion hinge release handle | 12. Seat cushion hinge cover |
| 13. Outboard seat cushion pivot riser | 14. Seat cushion hinge assembly | 15. Seatback frame |
| 16. Seatback latch assembly | 17. Seatback latch release strap | 18. Outboard headrest locking guide |
| 19. Seat cushion assembly | 20. Seatback assembly | |

Bench Seat RH (Crew Cab)

SEC. 880

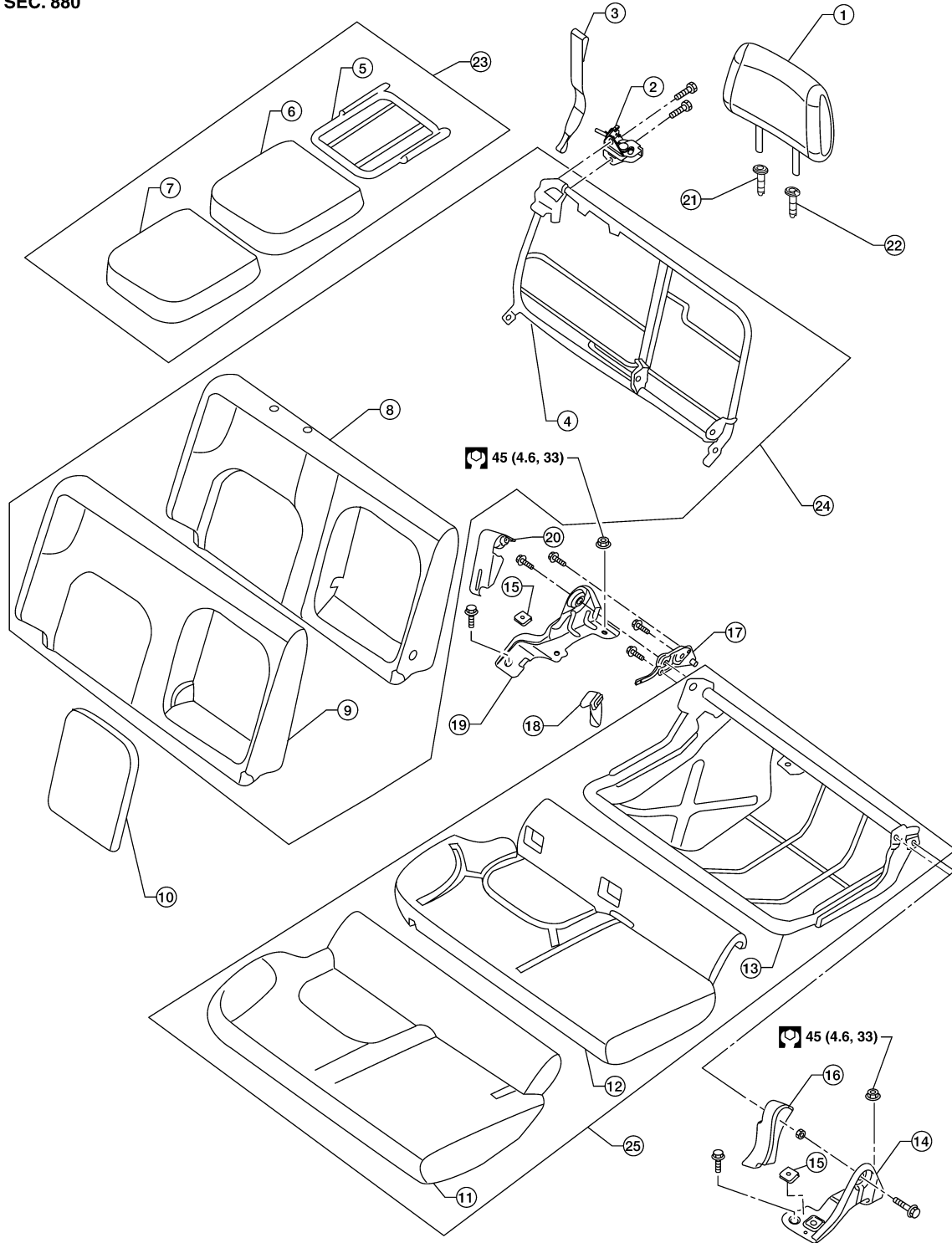

A
B
C
D
E
F
G
H
I
SE
K
L
M
N
O
P

WIIA1060E

REAR SEAT

< UNIT DISASSEMBLY AND ASSEMBLY >

- | | | |
|------------------------------------|---------------------------------|---------------------------------------|
| 1. Headrest | 2. Seatback latch assembly | 3. Seatback latch release strap |
| 4. Seatback frame | 5. Armrest frame | 6. Armrest pad |
| 7. Armrest trim cover | 8. Seatback pad | 9. Seatback trim cover |
| 10. Seatback armrest opening board | 11. Seat cushion trim cover | 12. Seat cushion pad |
| 13. Seat cushion frame | 14. Inboard pivot riser | 15. Seat cushion bumper RH/LH |
| 16. Inboard pivot riser cover | 17. Seat cushion hinge assembly | 18. Seat cushion hinge release handle |
| 19. Outboard pivot riser | 20. Outboard pivot riser cover | 21. Outboard headrest guide |
| 22. Inboard headrest locking guide | 23. Armrest assembly | 24. Seatback assembly |
| 25. Seat cushion assembly | | |