

SECTION **BCS**

BODY CONTROL SYSTEM

A
B
C

CONTENTS

BASIC INSPECTION	DOOR LOCK	F
INSPECTION AND ADJUSTMENT	DOOR LOCK : CONSULT Function (BCM - DOOR LOCK)	
ADDITIONAL SERVICE WHEN REPLACING CONTROL UNIT (BCM)	REAR DEFOGGER	G
ADDITIONAL SERVICE WHEN REPLACING CONTROL UNIT (BCM) : Description	REAR DEFOGGER : CONSULT Function (BCM - REAR DEFOGGER)	
ADDITIONAL SERVICE WHEN REPLACING CONTROL UNIT (BCM) : Work Procedure	BUZZER	H
CONFIGURATION (BCM)	BUZZER : CONSULT Function (BCM - BUZZER)...	
CONFIGURATION (BCM) : Description	INT LAMP	I
CONFIGURATION (BCM) : Work Procedure	INT LAMP : CONSULT Function (BCM - INT LAMP)	
CONFIGURATION (BCM) : Configuration List	MULTI REMOTE ENT	J
SYSTEM DESCRIPTION	MULTI REMOTE ENT : CONSULT Function (BCM - MULTI REMOTE ENT)	
BODY CONTROL SYSTEM	HEADLAMP	K
System Description	HEADLAMP : CONSULT Function (BCM - HEADLAMP)	
Component Parts Location	WIPER	L
COMBINATION SWITCH READING SYSTEM	WIPER : CONSULT Function (BCM - WIPER)	
..... 7	FLASHER	BCS
System Diagram	FLASHER : CONSULT Function (BCM - FLASHER)	
System Description	AIR CONDITIONER	N
Component Parts Location	AIR CONDITIONER : CONSULT Function (BCM - AIR CONDITIONER)	
SIGNAL BUFFER SYSTEM	COMB SW	O
System Diagram	COMB SW : CONSULT Function (BCM - COMB SW)	
System Description	BCM	P
POWER CONSUMPTION CONTROL SYSTEM	BCM : CONSULT Function (BCM - BCM)	
System Diagram	IMMU	
System Description	IMMU : CONSULT Function (BCM - IMMU)	
Component Parts Location		
DIAGNOSIS SYSTEM (BCM)		
COMMON ITEM		
COMMON ITEM : CONSULT Function (BCM - COMMON ITEM)		

BATTERY SAVER	21	COMBINATION SWITCH OUTPUT CIRCUIT ...	30
BATTERY SAVER : CONSULT Function (BCM - BATTERY SAVER)	22	Diagnosis Procedure	30
THEFT ALM	22	Special Repair Requirement	31
THEFT ALM : CONSULT Function (BCM - THEFT ALM)	22	ECU DIAGNOSIS INFORMATION	32
RETAINED PWR	23	BCM (BODY CONTROL MODULE)	32
RETAINED PWR : CONSULT Function (BCM - RETAINED PWR)	23	Reference Value	32
SIGNAL BUFFER	23	Terminal Layout	35
SIGNAL BUFFER : CONSULT Function (BCM - SIGNAL BUFFER)	23	Physical Values	35
AIR PRESSURE MONITOR	23	Fail Safe	40
AIR PRESSURE MONITOR : CONSULT Function (BCM - AIR PRESSURE MONITOR)	24	DTC Inspection Priority Chart	40
PANIC ALARM	24	DTC Index	41
PANIC ALARM : CONSULT Function (BCM - PANIC ALARM)	24	WIRING DIAGRAM	43
DTC/CIRCUIT DIAGNOSIS	26	BCM (BODY CONTROL MODULE)	43
U1000 CAN COMM CIRCUIT	26	Wiring Diagram	43
Description	26	SYMPTOM DIAGNOSIS	47
DTC Logic	26	COMBINATION SWITCH SYSTEM SYMP- TOMS	47
Diagnosis Procedure	26	Symptom Table	47
POWER SUPPLY AND GROUND CIRCUIT	27	PRECAUTION	48
Diagnosis Procedure	27	PRECAUTIONS	48
COMBINATION SWITCH INPUT CIRCUIT	29	Precaution for Supplemental Restraint System (SRS) "AIR BAG" and "SEAT BELT PRE-TEN- SIONER"	48
Diagnosis Procedure	29	REMOVAL AND INSTALLATION	49
Special Repair Requirement	29	BCM (BODY CONTROL MODULE)	49
		Removal and Installation	49

INSPECTION AND ADJUSTMENT

< BASIC INSPECTION >

BASIC INSPECTION

INSPECTION AND ADJUSTMENT

ADDITIONAL SERVICE WHEN REPLACING CONTROL UNIT (BCM)

ADDITIONAL SERVICE WHEN REPLACING CONTROL UNIT (BCM) : Description

INFOID:000000008792562

BEFORE REPLACEMENT

When replacing BCM, save or print current vehicle specification with CONSULT configuration before replacement.

NOTE:

If "Before Replace ECU" cannot be used, use the "After Replace ECU" or "Manual Configuration" after replacing BCM.

AFTER REPLACEMENT

CAUTION:

- When replacing BCM, you must perform "After Replace ECU" with CONSULT.
- Complete the procedure of "After Replace ECU" in order.
- If you set incorrect "After Replace ECU", incidents might occur.
- Configuration is different for each vehicle model. Confirm configuration of each vehicle model.
- When replacing BCM, perform the system initialization (NATS).

ADDITIONAL SERVICE WHEN REPLACING CONTROL UNIT (BCM) : Work Procedure

INFOID:000000008792563

1. SAVING VEHICLE SPECIFICATION

CONSULT

Enter "Re/Programming, Configuration" and perform "Before Replace ECU" to save or print current vehicle specification.

NOTE:

If "Before Replace ECU" cannot be used, use the "After Replace ECU" or "Manual Configuration" after replacing BCM.

>> GO TO 2.

2. REPLACE BCM

Replace BCM. Refer to [BCS-49. "Removal and Installation"](#).

>> GO TO 3.

3. WRITING VEHICLE SPECIFICATION

CONSULT

1. Enter "Re/Programming, Configuration".
2. If "Before Replace ECU" operation was performed, automatically an "Operation Log Selection" screen will be displayed. Select the applicable file from the "Saved Data List" and press "Confirm" to write vehicle specification. Refer to [BCS-4. "CONFIGURATION \(BCM\) : Work Procedure"](#).
3. If "Before Replace ECU" operation was not performed, select "After Replace ECU" or "Manual Configuration" to write vehicle specification. Refer to [BCS-4. "CONFIGURATION \(BCM\) : Work Procedure"](#).

>> GO TO 4.

4. INITIALIZE BCM (NATS)

Perform BCM initialization. (NATS)

>> Work End.

CONFIGURATION (BCM)

A
B
C
D
E
F
G
H
I
J
K
L
N
O
P

BCS

INSPECTION AND ADJUSTMENT

< BASIC INSPECTION >

CONFIGURATION (BCM) : Description

INFOID:000000008792564

Vehicle specification needs to be written with CONSULT because it is not written after replacing BCM. Configuration has three functions as follows:

Function	Description
"Before Replace ECU"	<ul style="list-style-type: none">• Reads the vehicle configuration of current BCM.• Saves the read vehicle configuration.
"After Replace ECU"	Writes the vehicle configuration with manual selection.
"Select Saved Data List"	Writes the vehicle configuration with saved data.

CAUTION:

- When replacing BCM, you must perform "Select Saved Data List" or "After Replace ECU" with CONSULT.
- Complete the procedure of "Select Saved Data List" or "After Replace ECU" in order.
- If you set incorrect "Select Saved Data List" or "After Replace ECU", incidents might occur.
- Configuration is different for each vehicle model. Confirm configuration of each vehicle model.
- Never perform "Select Saved Data List" or "After Replace ECU" except for new BCM.

CONFIGURATION (BCM) : Work Procedure

INFOID:000000008792565

1. WRITING MODE SELECTION

CONSULT

Select "Reprogramming, Configuration" of BCM.

When writing saved data >> GO TO 2.

When writing manually >> GO TO 3.

2. PERFORM "SAVED DATA LIST"

CONSULT

Automatically "Operation Log Selection" window will display if "Before Replace ECU" was performed. Select applicable file from the "Save Data List" and press "Confirm".

>> Work End.

3. PERFORM "AFTER REPLACE ECU" OR "MANUAL CONFIGURATION"

CONSULT

1. Select "After Replace ECU" or "Manual Configuration".
2. Identify the correct model and configuration list. Refer to [BCS-5, "CONFIGURATION \(BCM\) : Configuration List"](#).
3. Confirm and/or change setting value for each item.

CAUTION:

Thoroughly read and understand the vehicle specification. ECU control may not operate normally if the setting is not correct.

4. Select "Next".

CAUTION:

Make sure to select "Next", confirm each setting value and press "OK" even if the indicated configuration of brand new BCM is same as the desirable configuration. If not, configuration which is set automatically by selecting vehicle model can not be memorized.

5. When "Completed", select "End".

>> GO TO 4.

4. OPERATION CHECK

Confirm that each function controlled by BCM operates normally.

>> Work End.

INSPECTION AND ADJUSTMENT

< BASIC INSPECTION >

CONFIGURATION (BCM) : Configuration List

INFOID:000000008792566

CAUTION:

Thoroughly read and understand the vehicle specification. Incorrect settings may result in abnormal control of ECU.

MANUAL SETTING ITEM	
Items	Setting value
KEYLESS ENTRY	WITH ⇔ WITHOUT
I-KEY	WITH ⇔ WITHOUT
AUTO LIGHT	WITH ⇔ WITHOUT
DTRL	WITH ⇔ WITHOUT
THEFT ALARM	WITH ⇔ WITHOUT
AUTO DOOR UNLOCK TIMING	A/T ⇔ M/T

⇔: Items which confirm vehicle specifications

A
B
C
D
E
F
G
H
I
J
K
L
N
O
P

BCS

BODY CONTROL SYSTEM

< SYSTEM DESCRIPTION >

SYSTEM DESCRIPTION

BODY CONTROL SYSTEM

System Description

INFOID:000000008792567

OUTLINE

- BCM (Body Control Module) controls the various electrical components. It inputs the information required to the control from CAN communication and the signal received from each switch and sensor.
- BCM has combination switch reading function for reading the operation status of combination switches (light, turn signal, wiper and washer) in addition to a function for controlling the operation of various electrical components. It also has the signal transmission function as the passed point of signal and the power consumption control function that reduces the power consumption with the ignition switch OFF.
- BCM is equipped with the diagnosis function that performs the diagnosis with CONSULT and various settings.

BCM control function list

System	Refer to
Combination switch reading system	BCS-7. "System Diagram"
Signal buffer system	BCS-11. "System Diagram"
Power consumption control system	BCS-12. "System Diagram"
Auto light system	EXL-12. "System Diagram"
Turn signal and hazard warning lamp system	EXL-17. "System Diagram"
Headlamp system	EXL-7. "System Diagram"
Front fog lamp system (if equipped)	EXL-15. "System Diagram"
Daytime running light system (Canada only)	EXL-9. "System Diagram"
Interior room lamp control system	INL-6. "System Diagram"
Interior room lamp battery saver system	INL-6. "System Description"
Front wiper and washer system	WW-4. "System Diagram"
Warning chime system	WCS-4. "WARNING CHIME SYSTEM : System Diagram"
Door lock system (if equipped)	DLK-12. "DOOR LOCK AND UNLOCK SWITCH : System Diagram"
(NATS) Nissan anti-theft system (if equipped)	SEC-8. "System Diagram"
Vehicle security system (if equipped)	SEC-11. "System Diagram"
Remote keyless entry system (if equipped)	DLK-14. "REMOTE KEYLESS ENTRY : System Diagram"
Power window system (if equipped)	PWC-4. "System Diagram"
RAP (retained accessory power) system	PWC-4. "System Description"
TPMS (tire pressure monitoring system)	WT-9. "System Diagram"

Component Parts Location

INFOID:000000008792568

- BCM M18, M19, M20 (view with lower instrument panel LH removed)

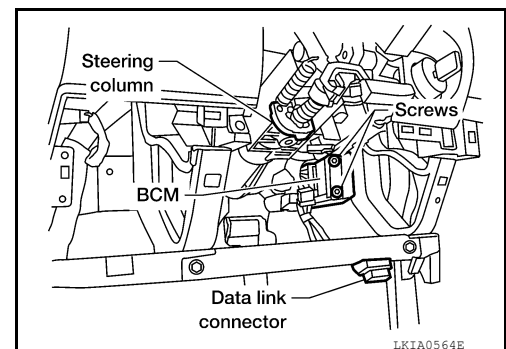

COMBINATION SWITCH READING SYSTEM

< SYSTEM DESCRIPTION >

COMBINATION SWITCH READING SYSTEM

System Diagram

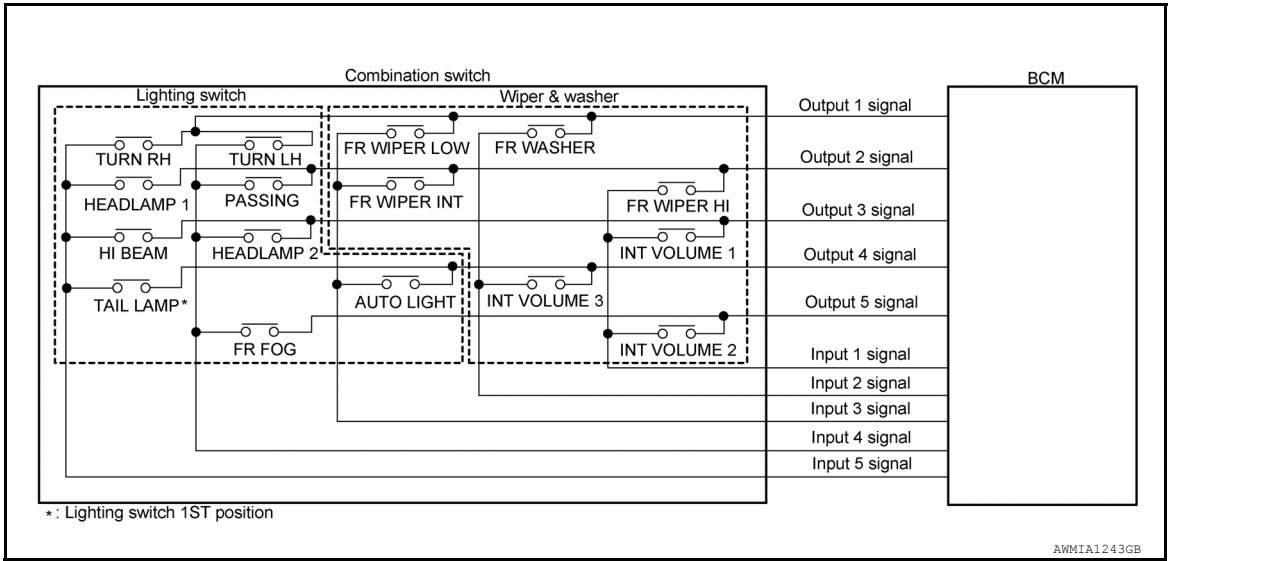

System Description

INFOID:000000008792570

OUTLINE

- BCM reads the status of the combination switch (light, turn signal, wiper and washer) and recognizes the status of each switch.
- BCM has a combination of 5 output terminals (OUTPUT 1 - 5) and 5 input terminals (INPUT 1 - 5) and reads a maximum of 20 switch states.

COMBINATION SWITCH MATRIX

Combination switch circuit

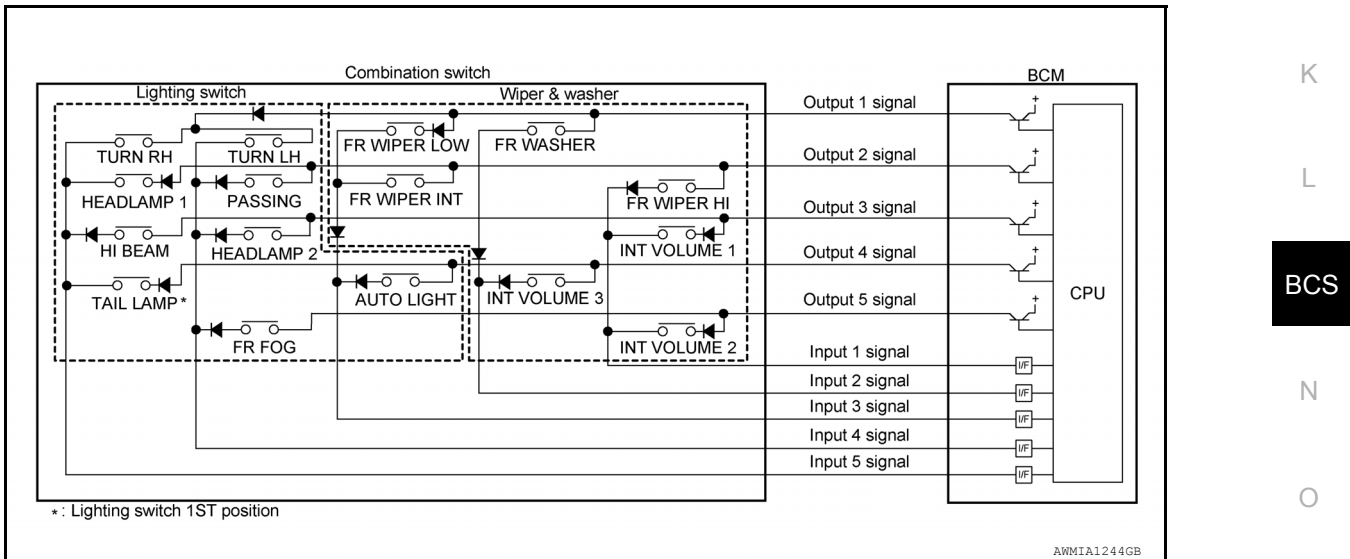

Combination switch INPUT-OUTPUT system list

System	INPUT 1	INPUT 2	INPUT 3	INPUT 4	INPUT 5
OUTPUT 1	—	FR WASHER	FR WIPER LOW	TURN LH	TURN RH
OUTPUT 2	FR WIPER HI	—	FR WIPER INT	PASSING	HEADLAMP 1
OUTPUT 3	INT VOLUME 1	—	—	HEADLAMP 2	HI BEAM

COMBINATION SWITCH READING SYSTEM

< SYSTEM DESCRIPTION >

System	INPUT 1	INPUT 2	INPUT 3	INPUT 4	INPUT 5
OUTPUT 4	—	INT VOLUME 3	AUTO LIGHT	—	TAIL LAMP
OUTPUT 5	INT VOLUME 2	—	—	FR FOG	—

COMBINATION SWITCH READING FUNCTION

Description

- BCM reads the status of the combination switch at 10 ms intervals normally.

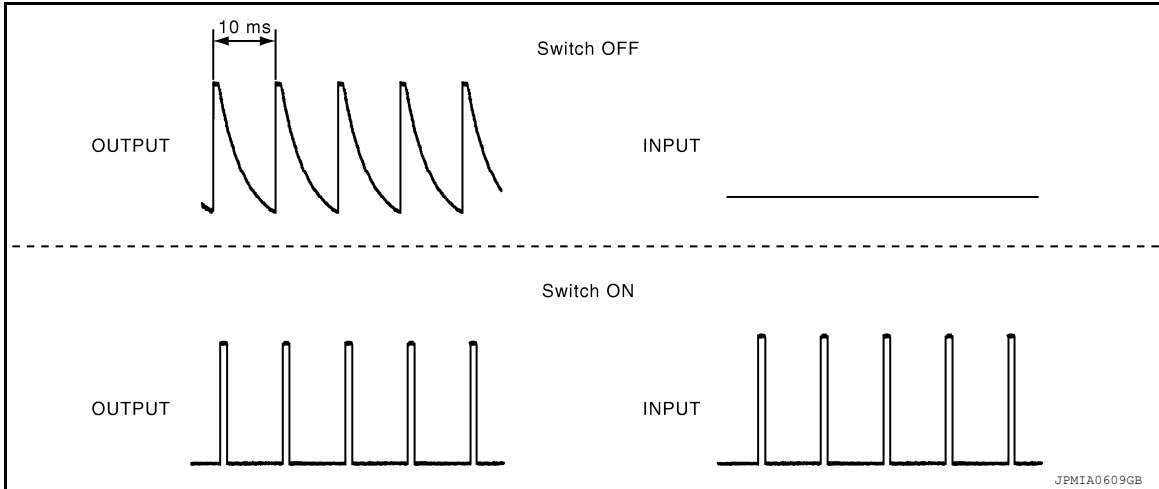

NOTE:

BCM reads the status of the combination switch at 60 ms intervals when BCM is controlled at low power consumption control mode.

- BCM operates as follows and judges the status of the combination switch.
 - It operates the transistor on OUTPUT side in the following order: OUTPUT 1 → 2 → 3 → 4 → 5, and outputs voltage waveform.
 - The voltage waveform of OUTPUT corresponding to the formed circuit is input into the interface on INPUT side if any (1 or more) switches are ON.
 - It reads this change of the voltage as the status signal of the combination switch.

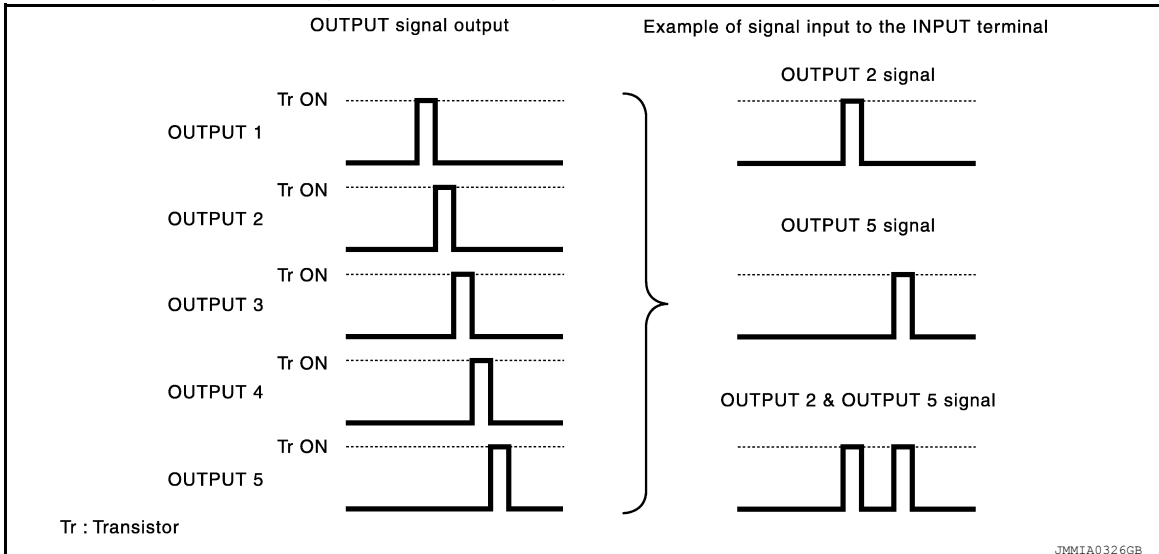

Operation Example

In the following operation example, the combination of the status signals of the combination switch is replaced as follows: INPUT 1 - 5 to "1 - 5" and OUTPUT 1 - 5 to "A - E".

Example 1: When a switch (TAIL LAMP) is turned ON

COMBINATION SWITCH READING SYSTEM

< SYSTEM DESCRIPTION >

- The circuit between OUTPUT 4 and INPUT 5 is formed when the TAIL LAMP switch is turned ON.

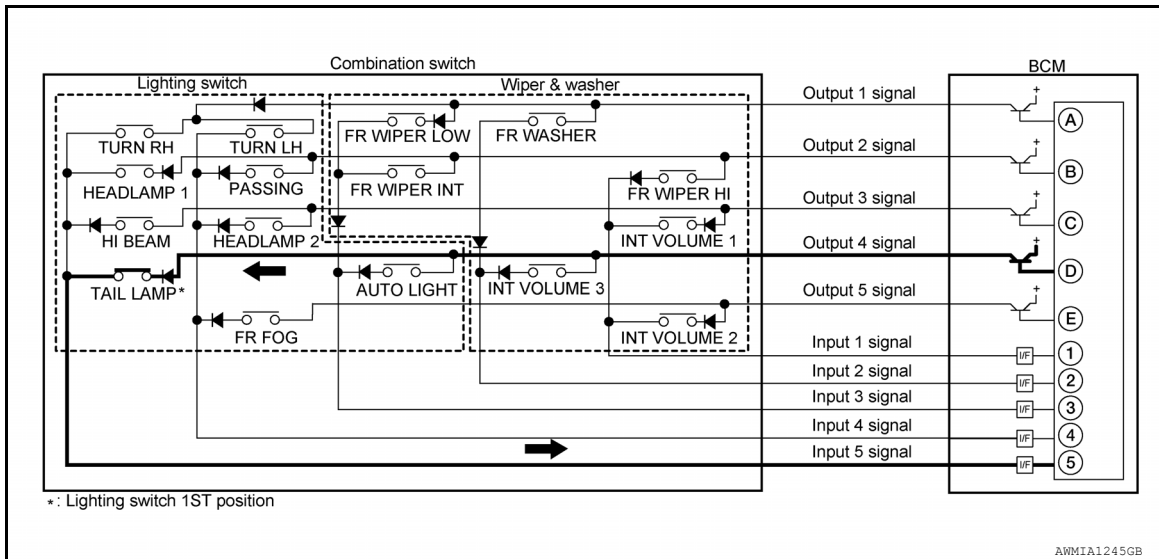

- BCM detects the combination switch status signal "5D" when the signal of OUTPUT 4 is input to INPUT 5.
- BCM judges that the TAIL LAMP switch is ON when the signal "5D" is detected.

Example 2: When some switches (TURN RH, TAIL LAMP) are turned ON

- The circuits between OUTPUT 1 and INPUT 5 and between OUTPUT 4 and INPUT 5 are formed when the TURN RH switch and TAIL LAMP switch are turned ON.

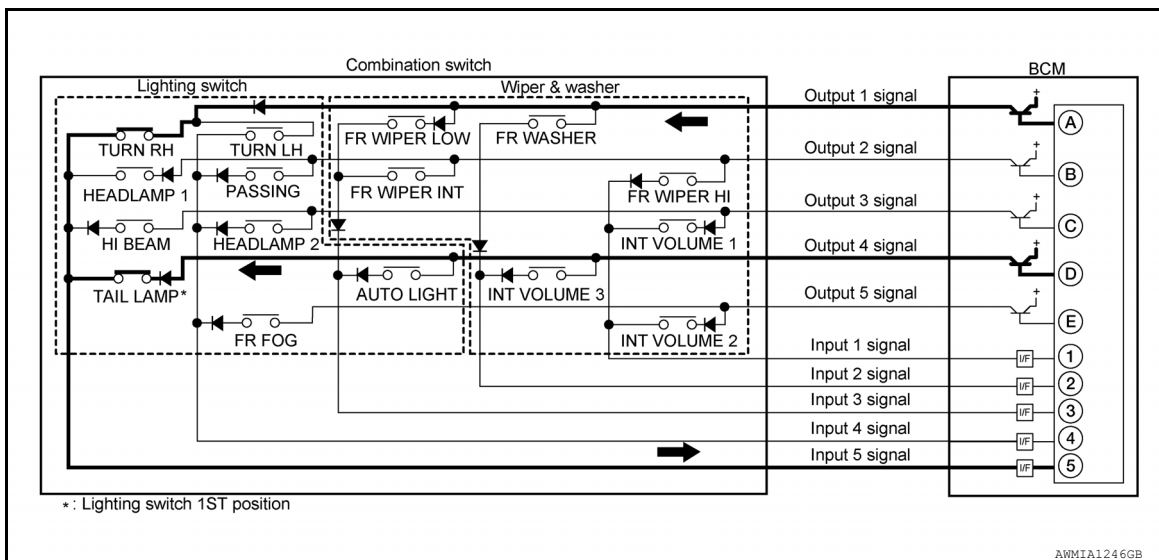

- BCM detects the combination switch status signal "5AD" when the signals of OUTPUT 1 and OUTPUT 4 are input to INPUT 5.
- BCM judges that the TURN RH switch and TAIL LAMP switch are ON when the signal "5AD" is detected.

WIPER INTERMITTENT DIAL POSITION SETTING (FRONT WIPER INTERMITTENT OPERATION)

BCM judges the wiper intermittent dial 1 - 7 by the status of INT VOLUME 1, 2, and 3 switches.

COMBINATION SWITCH READING SYSTEM

< SYSTEM DESCRIPTION >

Wiper intermittent dial position	Intermittent operation delay interval	INT VOLUME switch ON/OFF status		
		INT VOLUME 1	INT VOLUME 2	INT VOLUME 3
1	Short ↑	ON	ON	ON
2		ON	ON	OFF
3		ON	OFF	OFF
4		OFF	OFF	OFF
5	↓ Long	OFF	OFF	ON
6		OFF	ON	ON
7		OFF	ON	OFF

Component Parts Location

INFOID:000000008792571

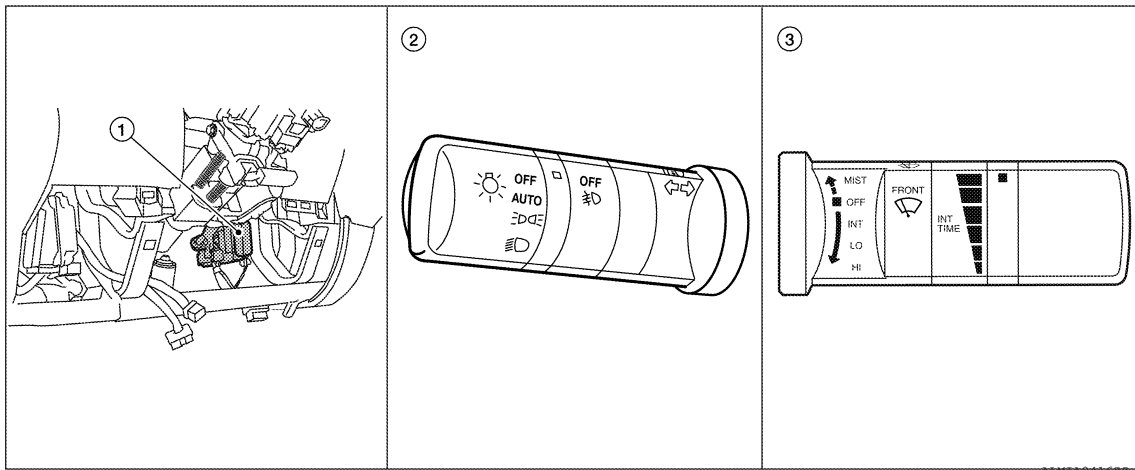

ALMIA041622

1. BCM M18, M19, M20 (view with lower instrument panel LH removed)
2. Combination switch (lighting and turn signal switch) M28
3. Combination switch (wiper and washer switch) M28

SIGNAL BUFFER SYSTEM

< SYSTEM DESCRIPTION >

SIGNAL BUFFER SYSTEM

System Diagram

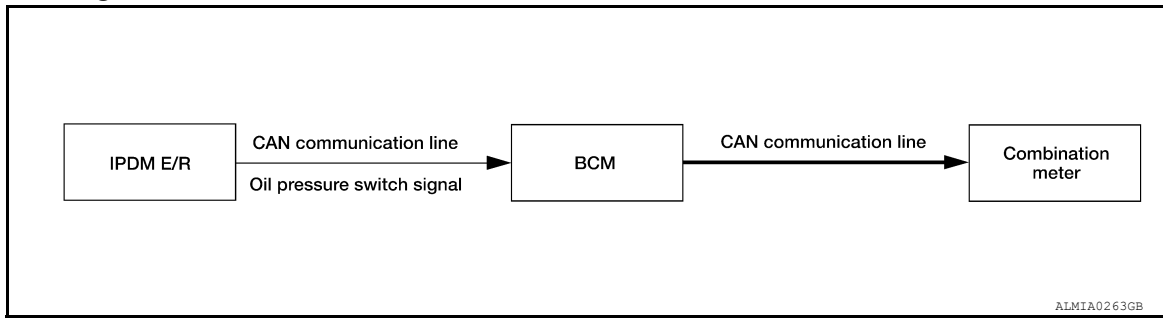

System Description

INFOID:000000008792573

OUTLINE

BCM has the signal transmission function that outputs/transmits each input/received signal to each unit.

Signal transmission function list

Signal name	Input	Output	Description
Oil pressure switch signal	IPDM E/R (CAN)	Combination meter (CAN)	Transmits the received oil pressure switch signal via CAN communication.

A
B
C
D
E
F
G
H
I
J
K
L

BCS

N
O
P

POWER CONSUMPTION CONTROL SYSTEM

< SYSTEM DESCRIPTION >

POWER CONSUMPTION CONTROL SYSTEM

System Diagram

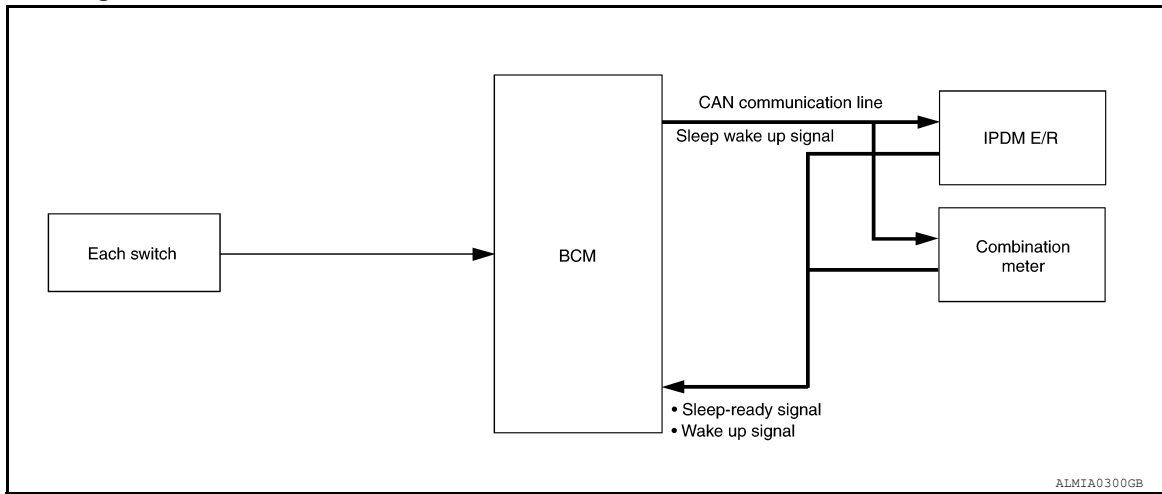

System Description

INFOID:000000008792575

OUTLINE

- BCM incorporates a power consumption control function that reduces the power consumption according to the vehicle status.
- BCM switches the status (control mode) by itself with the power saving control function. It performs the sleep request to each unit (IPDM E/R and combination meter) that operates with the ignition switch OFF.

Normal mode (wake-up)

- CAN communication is normally performed with other units
- Each control with BCM is operating properly

CAN communication sleep mode (CAN sleep)

- CAN transmission is stopped
- Control with BCM only is operating

Low power consumption mode (BCM sleep)

- Low power consumption control is active
- CAN transmission is stopped

LOW POWER CONSUMPTION CONTROL WITH BCM

BCM reduces the power consumption with the following operation in the low power consumption mode.

- The reading interval of the each switches changes from 10 ms interval to 20 ms interval.

Sleep mode activation

- BCM receives the sleep-ready signal (ready) from IPDM E/R and combination meter via CAN communication.
- BCM transmits the sleep wake up signal (sleep) to each unit when all of the CAN sleep conditions are fulfilled.
- Each unit stops the transmission of CAN communication with the sleep wake up signal. BCM is in CAN communication sleep mode.
- BCM is in the low power consumption mode and perform the low power consumption control when all of the BCM sleep conditions are fulfilled with CAN sleep condition.

POWER CONSUMPTION CONTROL SYSTEM

< SYSTEM DESCRIPTION >

Sleep condition

CAN sleep condition	BCM sleep condition
<ul style="list-style-type: none"> • Receiving the sleep-ready signal (ready) from all units • Ignition switch: OFF • Vehicle security system alarm: No operation • Warning lamp: No operation • Warning chime: No operation • Stop lamp switch: OFF • Key switch status: No change for 2 seconds • Hazard warning lamp: No operation • Exterior lamp: OFF • Door lock status: No change for 2 seconds • CONSULT communication status: No communication • Door switch status: No change for 2 seconds 	<p>The controls only BCM are completed. (Interior room lamp battery saver: Time out etc.)</p>

Wake-up operation

- BCM transmits sleep wake up signal (wake up) to each unit when any condition listed below is established, and then goes into normal mode from low power consumption mode.
- Each unit starts transmissions with CAN communication by receiving sleep wake up signals. Each unit transmits wake up signals to BCM with CAN communication to convey the start of CAN communication.

Wake-up condition

BCM wake-up condition
<ul style="list-style-type: none"> • Ignition switch: OFF → ACC or ON • Stop lamp switch: ON (Depress brake pedal) • Any door switch: OFF → ON • Lighting switch: OFF → 1ST or PASS • Hazard switch: OFF → ON • Remote keyless entry receiver: Receiving (with remote keyless entry)

Component Parts Location

INFOID:000000008792576

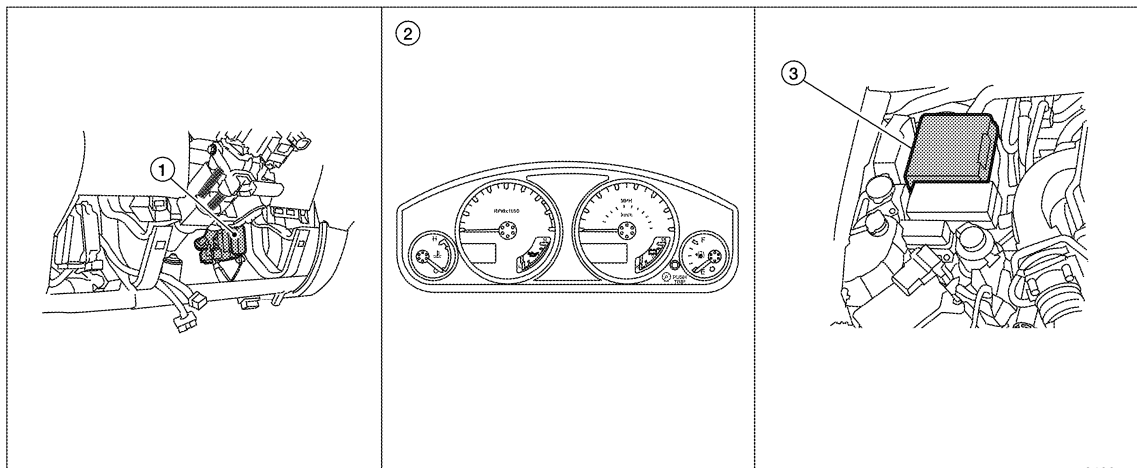

1. BCM M18, M19, M20 (view with lower instrument panel LH removed)
2. Combination meter M24
3. IPDM E/R

DIAGNOSIS SYSTEM (BCM)

< SYSTEM DESCRIPTION >

DIAGNOSIS SYSTEM (BCM)

COMMON ITEM

COMMON ITEM : CONSULT Function (BCM - COMMON ITEM)

INFOID:000000008792577

APPLICATION ITEM

CONSULT performs the following functions via CAN communication with BCM.

Direct Diagnostic Mode	Description
Ecu Identification	The BCM part number is displayed.
Self Diagnostic Result	The BCM self diagnostic results are displayed.
Data Monitor	The BCM input/output data is displayed in real time.
Active Test	The BCM activates outputs to test components.
Work support	The settings for BCM functions can be changed.
Configuration	<ul style="list-style-type: none"> • The vehicle specification can be read and saved. • The vehicle specification can be written when replacing BCM.
CAN Diag Support Mntr	The result of transmit/receive diagnosis of CAN communication is displayed.

SYSTEM APPLICATION

BCM can perform the following functions.

System	Sub System	Direct Diagnostic Mode						
		Ecu Identification	Self Diagnostic Result	Data Monitor	Active Test	Work support	Configuration	CAN Diag Support Mntr
Door lock	DOOR LOCK			x	x	x		
Rear window defogger	REAR DEFOGGER			x	x			
Warning chime	BUZZER			x	x			
Interior room lamp timer	INT LAMP			x	x	x		
Remote keyless entry system	MULTI REMOTE ENT			x	x	x		
Exterior lamp	HEAD LAMP			x	x	x		
Wiper and washer	WIPER			x	x	x		
Turn signal and hazard warning lamps	FLASHER			x	x			
Air conditioner	AIR CONDITIONER			x				
Combination switch	COMB SW			x				
BCM	BCM	x	x			x	x	x
Immobilizer	IMMU		x	x	x			
Interior room lamp battery saver	BATTERY SAVER			x	x	x		
Vehicle security system	THEFT ALM			x	x	x		
RAP system	RETAINED PWR			x	x	x		
Signal buffer system	SIGNAL BUFFER			x	x			
TPMS	AIR PRESSURE MONITOR		x	x	x	x		
Panic alarm system	PANIC ALARM				x			

DOOR LOCK

DIAGNOSIS SYSTEM (BCM)

< SYSTEM DESCRIPTION >

DOOR LOCK : CONSULT Function (BCM - DOOR LOCK)

INFOID:000000008792578

DATA MONITOR

Monitor Item [Unit]	Description
IGN ON SW [On/Off]	Indicates condition of ignition switch ON position.
KEY ON SW [On/Off]	Indicates condition of key switch.
CDL LOCK SW [On/Off]	Indicates condition of lock signal from door lock and unlock switch.
CDL UNLOCK SW [On/Off]	Indicates condition of unlock signal from door lock and unlock switch.
DOOR SW-DR [On/Off]	Indicates condition of front door switch LH.
DOOR SW-AS [On/Off]	Indicates condition of front door switch RH.
DOOR SW-RR [On/Off]	Indicates condition of rear door switch RH.
DOOR SW-RL [On/Off]	Indicates condition of rear door switch LH.
KEY CYL LK-SW [On/Off]	Indicates condition of lock signal from door key cylinder switch.
KEY CYL UN-SW [On/Off]	Indicates condition of unlock signal from door key cylinder switch.
KEYLESS LOCK [On/Off]	Indicates condition of lock signal from keyfob.
KEYLESS UNLOCK [On/Off]	Indicates condition of unlock signal from keyfob.

ACTIVE TEST

Test Item	Description
DOOR LOCK	This test is able to check door lock operation [OTR ULK/DR UNLK/ALL ULK/ALL LCK].

WORK SUPPORT

Support Item	Setting	Description
DOOR LOCK-UNLOCK SET	On*	Automatic door locks function ON.
	Off	Automatic door locks function OFF.
ANTI-LOCK OUT SET	Off	Anti lock out function OFF.
	On*	Anti lock out function ON.
AUTOMATIC DOOR LOCK SELECT	SHIFT OUT OF P	Doors lock automatically when shifted out of park (P).
	VH SPD*	Doors lock automatically when vehicle speed reaches 24 km/h (15 mph).
AUTOMATIC DOOR UNLOCK SELECT	MODE6	Drivers door unlocks automatically when key is removed.
	MODE5	Drivers door unlocks automatically when shifted into park (P).
	MODE4	Drivers door unlocks automatically when ignition is switched from ON to OFF.
	MODE3	Doors unlock automatically when key is removed.
	MODE2*	Doors unlock automatically when shifted into park (P).
AUTOMATIC LOCK/UNLOCK SELECT	MODE1	Doors unlock automatically when ignition is switched from ON to OFF.
	On	Automatic lock/unlock function ON.
	Off*	Automatic lock/unlock function OFF.

* : Initial setting

REAR DEFOGGER

REAR DEFOGGER : CONSULT Function (BCM - REAR DEFOGGER)

INFOID:000000008792579

DATA MONITOR

DIAGNOSIS SYSTEM (BCM)

< SYSTEM DESCRIPTION >

Monitor Item [Unit]	Description
IGN ON SW [On/Off]	Indicates condition of ignition switch ON position.
ACC ON SW [On/Off]	Indicates condition of ignition switch ACC position.
REAR DEF SW [On/Off]	Indicates condition of rear window defogger switch.

ACTIVE TEST

Test Item	Description
REAR DEFOGGER	This test is able to check rear window defogger operation [Off/On].

BUZZER

BUZZER : CONSULT Function (BCM - BUZZER)

INFOID:000000008792580

DATA MONITOR

Monitor Item [Unit]	Description
DOOR SW-DR [On/Off]	Indicates condition of front door switch LH.
IGN ON SW [On/Off]	Indicates condition of ignition switch ON position.
KEY ON SW [On/Off]	Indicates condition of key switch.
LIGHT SW 1ST [On/Off]	Indicates condition of combination switch.
BUCKLE SW [On/Off]	Indicates condition of seat belt buckle switch.

ACTIVE TEST

Test Item	Description
SEAT BELT WARN TEST	This test is able to check seat belt warning operation [Off/On].
LIGHT WARN ALM	This test is able to check light reminder warning operation [Off/On].
IGN KEY WARN ALM	This test is able to check key warning chime operation [Off/On].

INT LAMP

INT LAMP : CONSULT Function (BCM - INT LAMP)

INFOID:000000008792581

DATA MONITOR

Monitor Item [Unit]	Description
IGN ON SW [On/Off]	Indicates condition of ignition switch ON position.
KEY ON SW [On/Off]	Indicates condition of key switch.
DOOR SW-DR [On/Off]	Indicates condition of front door switch LH.
DOOR SW-AS [On/Off]	Indicates condition of front door switch RH.
DOOR SW-RR [On/Off]	Indicates condition of rear door switch RH.
DOOR SW-RL [On/Off]	Indicates condition of rear door switch LH.
KEY CYL LK-SW [On/Off]	Indicates condition of lock signal from door key cylinder switch.
KEY CYL UN-SW [On/Off]	Indicates condition of unlock signal from door key cylinder switch.
CDL LOCK SW [On/Off]	Indicates condition of lock signal from door lock and unlock switch.
CDL UNLOCK SW [On/Off]	Indicates condition of unlock signal from door lock and unlock switch.
KEYLESS LOCK [On/Off]	Indicates condition of lock signal from keyfob.
KEYLESS UNLOCK [On/Off]	Indicates condition of unlock signal from keyfob.

ACTIVE TEST

DIAGNOSIS SYSTEM (BCM)

< SYSTEM DESCRIPTION >

Test Item	Description
IGN ILLUM	This test is able to check ignition keyhole illumination operation [Off/On].
INT LAMP	This test is able to check interior room lamp operation [Off/On].

WORK SUPPORT

Support Item	Setting	Description
SET I/L D-UNLCK INTCON	Off	Interior room lamp timer function OFF.
	On*	Interior room lamp timer function ON.
ROOM LAMP ON TIME SET	MODE7	0 sec.
	MODE6	5 sec.
	MODE5	4 sec.
	MODE4	3 sec.
	MODE3	2 sec.
	MODE2*	1 sec.
	MODE1	0.5 sec.
ROOM LAMP OFF TIME SET	MODE7	0 sec.
	MODE6	5 sec.
	MODE5	4 sec.
	MODE4	3 sec.
	MODE3	2 sec.
	MODE2*	1 sec.
	MODE1	0.5 sec.

* : Initial setting

MULTI REMOTE ENT

MULTI REMOTE ENT : CONSULT Function (BCM - MULTI REMOTE ENT)

INFOID:000000008792582

DATA MONITOR

Monitor Item [Unit]	Description
IGN ON SW [On/Off]	Indicates condition of ignition switch ON position.
KEY ON SW [On/Off]	Indicates condition of key switch.
ACC ON SW [On/Off]	Indicates condition of ignition switch ACC position.
KEYLESS LOCK [On/Off]	Indicates condition of lock signal from keyfob.
KEYLESS UNLOCK [On/Off]	Indicates condition of unlock signal from keyfob.
KEYLESS PANIC [On/Off]	Indicates condition of panic signal from keyfob.
DOOR SW-DR [On/Off]	Indicates condition of front door switch LH.
DOOR SW-AS [On/Off]	Indicates condition of front door switch RH.
DOOR SW-RR [On/Off]	Indicates condition of rear door switch RH.
DOOR SW-RL [On/Off]	Indicates condition of rear door switch LH.
CDL LOCK SW [On/Off]	Indicates condition of lock signal from door lock and unlock switch.
CDL UNLOCK SW [On/Off]	Indicates condition of unlock signal from door lock and unlock switch.
KEY CYL LK SW [On/Off]	Indicates condition of lock signal from door key cylinder switch.

ACTIVE TEST

DIAGNOSIS SYSTEM (BCM)

< SYSTEM DESCRIPTION >

Test Item	Description
DOOR LOCK	This test is able to check door lock operation [OTR ULK/DR UNLK/ALL ULK/ALL LCK].
FLASHER	This test is able to check hazard reminder operation [Off/LH/RH].
HORN	This test is able to check horn operation [On].

WORK SUPPORT

Support Item	Setting	Description	
HORN CHIRP SET	Off	Horn chirp function can be changed in this mode.	
	On*		
HAZARD LAMP SET	MODE4* Lock and Unlock	Hazard warning lamp function can be changed in this mode.	
	MODE3 Lock Only		
	MODE2 Unlock Only		
	MODE1 OFF		
MULTI ANSWER BACK SET	MODE2*	Lock	Hazard warning lamps flash twice and horn does not sound.
		Unlock	Hazard warning lamps do not flash and horn does not sound.
	MODE1	Lock	Hazard warning lamps flash twice and horn sounds once.
		Unlock	Hazard warning lamps flash once and horn does not sound.
AUTO LOCK SET	MODE3 1 min	Auto locking function can be changed in this mode.	
	MODE2 OFF		
	MODE1* 5 min		
PANIC ALRM SET	MODE3 1.5 sec	Panic alarm operation can be changed in this mode.	
	MODE2 OFF		
	MODE1* 0.5 sec		
REMO CONT ID REGIST	—	Keyfob ID code can be registered.	
REMO CONT ID ERASUR	—	Keyfob ID code can be erased.	
REMO CONT ID CONFIR	—	Keyfob ID code registration is displayed.	

*: Initial setting

HEADLAMP

HEADLAMP : CONSULT Function (BCM - HEADLAMP)

INFOID:000000008792583

DATA MONITOR

Monitor Item [Unit]	Description
IGN ON SW [On/Off]	Indicates condition of ignition switch ON position.
ACC ON SW [On/Off]	Indicates condition of ignition switch ACC position.
HI BEAM SW [On/Off]	Indicates condition of combination switch.
HEAD LAMP SW 1 [On/Off]	
HEAD LAMP SW 2 [On/Off]	
LIGHT SW 1ST [On/Off]	
AUTO LIGHT SW [On/Off]	
PASSING SW [On/Off]	
FR FOG SW [On/Off]	
DOOR SW-DR [On/Off]	Indicates condition of front door switch LH.
DOOR SW-AS [On/Off]	Indicates condition of front door switch RH.
DOOR SW-RR [On/Off]	Indicates condition of rear door switch RH.

DIAGNOSIS SYSTEM (BCM)

< SYSTEM DESCRIPTION >

Monitor Item [Unit]	Description
DOOR SW-RL [On/Off]	Indicates condition of rear door switch LH.
TURN SIGNAL R [On/Off]	Indicates condition of combination switch.
TURN SIGNAL L [On/Off]	
CARGO LAMP SW [On/Off]	Indicates condition of cargo lamp switch.
OPTICAL SENSOR [V]	Indicates voltage signal from optical sensor.

ACTIVE TEST

Test Item	Description
TAIL LAMP	This test is able to check tail lamp operation [Off/On].
HEAD LAMP	This test is able to check head lamp operation [Off/Lo/Hi].
FR FOG LAMP	This test is able to check front fog lamp operation [Off/On].
CARGO LAMP	This test is able to check cargo lamp operation [Off/On].

WORK SUPPORT

Support Item	Setting	Description
BATTERY SAVER SET	Off	Exterior lamp battery saver function OFF.
	On*	Exterior lamp battery saver function ON.
CUSTOM A/LIGHT SETTING	MODE4	Less sensitive setting than normal setting (Turns ON later than normal operation).
	MODE3	More sensitive setting than MODE 2 (Turns ON earlier than MODE 2).
	MODE2	More sensitive setting than normal setting (Turns ON earlier than normal operation).
	MODE1*	Normal.
ILL DELAY SET	MODE8	Sets delay timer function operation time (All doors closed).
	180 sec	
	MODE7	
	150 sec	
	MODE6	
	120 sec	
	MODE5	
	90 sec	
MODE4	60 sec	
MODE3		
MODE2	30 sec	
MODE1*	45 sec	

*: Initial setting

WIPER

WIPER : CONSULT Function (BCM - WIPER)

INFOID:000000008792584

DATA MONITOR

Monitor Item [Unit]	Description
IGN ON SW [On/Off]	Indicates condition of ignition switch ON position.
IGN SW CAN [On/Off]	Indicates ignition switch ON signal received from IPDM E/R on CAN communication line.
FR WIPER HI [On/Off]	Indicates condition of front wiper operation of combination switch.
FR WIPER LOW [On/Off]	
FR WIPER INT [On/Off]	
FR WASHER SW [On/Off]	
INT VOLUME [1 - 7]	

A
B
C
D
E
F
G
H
I
J
K
L

BCS

N
O

P

DIAGNOSIS SYSTEM (BCM)

< SYSTEM DESCRIPTION >

Monitor Item [Unit]	Description
FR WIPER STOP [On/Off]	Indicates front wiper motor auto stop signal received from IPDM E/R on CAN communication line.
VEHICLE SPEED [km/h/mph]	Indicates vehicle speed signal received from combination meter on CAN communication line.

ACTIVE TEST

Test Item	Description
FR WIPER	This test is able to check front wiper operation [Off/INT/Lo/Hi].

WORK SUPPORT

Support Item	Setting	Description
WIPER SPEED SETTING	Off*	Front wiper intermittent time linked with wiper dial position.
	On	Front wiper intermittent time linked with vehicle speed and wiper dial position.

* : Initial setting

FLASHER

FLASHER : CONSULT Function (BCM - FLASHER)

INFOID:000000008792585

DATA MONITOR

Monitor Item [Unit]	Description
IGN ON SW [On/Off]	Indicates condition of ignition switch ON position.
HAZARD SW [On/Off]	Indicates condition of hazard switch.
TURN SIGNAL R [On/Off]	Indicates condition of turn signal function of combination switch.
TURN SIGNAL L [On/Off]	
BRAKE SW [On/Off]	Indicates condition of brake switch.

ACTIVE TEST

Test Item	Description
FLASHER	This test is able to check turn signal lamp operation [Off/LH/RH].

AIR CONDITIONER

AIR CONDITIONER : CONSULT Function (BCM - AIR CONDITIONER)

INFOID:000000008792586

DATA MONITOR

Monitor Item [Unit]	Description
IGN ON SW [On/Off]	Indicates condition of ignition switch ON position.
FAN ON SIG [On/Off]	Indicates condition of fan switch.
AIR COND SW [On/Off]	Indicates condition of A/C switch.

COMB SW

COMB SW : CONSULT Function (BCM - COMB SW)

INFOID:000000008792587

DATA MONITOR

DIAGNOSIS SYSTEM (BCM)

< SYSTEM DESCRIPTION >

Monitor Item [Unit]	Description	
TURN SIGNAL R [On/Off]	Indicates condition of turn signal operation of combination switch.	A
TURN SIGNAL L [On/Off]		
HI BEAM SW [On/Off]	Indicates condition of hi beam operation of combination switch.	B
HEAD LAMP SW 1 [On/Off]	Indicates condition of headlamp operation of combination switch.	C
HEAD LAMP SW 2 [On/Off]		
LIGHT SW 1ST [On/Off]	Indicates condition of lighting operation of combination switch.	
PASSING SW [On/Off]	Indicates condition of passing switch operation of combination switch.	D
AUTO LIGHT SW [On/Off]	Indicates condition of auto light operation of combination switch.	
FR FOG SW [On/Off]	Indicates condition of front fog light operation of combination switch.	
FR WIPER HI [On/Off]	Indicates condition of front wiper operation of combination switch.	E
FR WIPER LOW [On/Off]		
FR WIPER INT [On/Off]		
FR WASHER SW [On/Off]	Indicates condition of front washer operation of combination switch.	F
INT VOLUME [1 - 7]	Indicates condition of intermittent wiper operation of combination switch.	

BCM

BCM : CONSULT Function (BCM - BCM)

INFOID:000000008792588

ECU IDENTIFICATION

The BCM part number is displayed.

SELF DIAGNOSTIC RESULT

Refer to [BCS-41, "DTC Index"](#).

WORK SUPPORT

Support Item	Setting	Description	
RESET SETTING VALUE	Reset	Returns BCM to initial value in factory shipment.	K
	Cancel	Cancels the reset function.	

CONFIGURATION

Refer to [BCS-4, "CONFIGURATION \(BCM\) : Description"](#).

CAN DIAG SUPPORT MNTR

Refer to [LAN-60, "CAN Diagnostic Support Monitor"](#).

IMMU

IMMU : CONSULT Function (BCM - IMMU)

INFOID:000000008792589

SELF DIAGNOSTIC RESULT

Refer to [BCS-41, "DTC Index"](#).

DATA MONITOR

Monitor Item [Unit]	Description	
IGN ON SW [On/Off]	Indicates condition of ignition switch ON position.	P

ACTIVE TEST

Test Item	Description	
THEFT IND	This test is able to check security indicator operation [Off/On].	

BATTERY SAVER

A
B
C
D
E
F
G
H
I
J
K
L

BCS

N

O

P

DIAGNOSIS SYSTEM (BCM)

< SYSTEM DESCRIPTION >

BATTERY SAVER : CONSULT Function (BCM - BATTERY SAVER)

INFOID:000000008792590

DATA MONITOR

Monitor Item [Unit]	Description
IGN ON SW [On/Off]	Indicates condition of ignition switch ON position.
KEY ON SW [On/Off]	Indicates condition of key switch.
DOOR SW-DR [On/Off]	Indicates condition of front door switch LH.
DOOR SW-AS [On/Off]	Indicates condition of front door switch RH.
DOOR SW-RR [On/Off]	Indicates condition of rear door switch RH.
DOOR SW-RL [On/Off]	Indicates condition of rear door switch LH.
KEY CYL LK SW [On/Off]	Indicates condition of lock signal from door key cylinder switch.
KEY CYL UN SW [On/Off]	Indicates condition of unlock signal from door key cylinder switch.
CDL LOCK SW [On/Off]	Indicates condition of lock signal from door lock and unlock switch.
CDL UNLOCK SW [On/Off]	Indicates condition of unlock signal from door lock and unlock switch.
KEYLESS LOCK [On/Off]	Indicates condition of lock signal from keyfob.
KEYLESS UNLOCK [On/Off]	Indicates condition of unlock signal from keyfob.

ACTIVE TEST

Test item	Description
BATTERY SAVER	This test is able to check battery saver operation [Off/On].

WORK SUPPORT

Support Item	Setting	Description
ROOM LAMP TIMER SET	MODE2	60 min
	MODE1	15 min
		Sets the interior room lamp battery saver timer operating time.

*: Initial setting

THEFT ALM

THEFT ALM : CONSULT Function (BCM - THEFT ALM)

INFOID:000000008792591

DATA MONITOR

Monitor Item [Unit]	Description
IGN ON SW [On/Off]	Indicates condition of ignition switch ON position.
ACC ON SW [On/Off]	Indicates condition of ignition switch ACC position.
KEYLESS LOCK [On/Off]	Indicates condition of lock signal from keyfob.
KEYLESS UNLOCK [On/Off]	Indicates condition of unlock signal from keyfob.
DOOR SW-DR [On/Off]	Indicates condition of front door switch LH.
DOOR SW-AS [On/Off]	Indicates condition of front door switch RH.
DOOR SW-RR [On/Off]	Indicates condition of rear door switch RH.
DOOR SW-RL [On/Off]	Indicates condition of rear door switch LH.
KEY CYL LK-SW [On/Off]	Indicates condition of lock signal from door key cylinder switch.
KEY CYL UN-SW [On/Off]	Indicates condition of unlock signal from door key cylinder switch.
CDL LOCK SW [On/Off]	Indicates condition of lock signal from door lock and unlock switch.
CDL UNLOCK SW [On/Off]	Indicates condition of unlock signal from door lock and unlock switch.

ACTIVE TEST

DIAGNOSIS SYSTEM (BCM)

< SYSTEM DESCRIPTION >

Test Item	Description
THEFT IND	This test is able to check security indicator lamp operation [Off/On].
VEHICLE SECURITY HORN	This test is able to check vehicle security horn operation [On].
HEADLAMP(HI)	This test is able to check vehicle security lamp operation [On].

WORK SUPPORT

Support Item	Setting	Description
SECURITY ALARM SET	Off	Security alarm OFF.
	On*	Security alarm ON.
THEFT ALM TRG	Off/On	The switch which triggered vehicle security alarm is recorded [On]. This mode is able to confirm and erase the record of vehicle security alarm. The trigger data can be erased by touching [CLEAR].
	CLEAR	

*: Initial setting

RETAINED PWR

RETAINED PWR : CONSULT Function (BCM - RETAINED PWR)

INFOID:000000008792592

DATA MONITOR

Monitor Item [Unit]	Description
IGN ON SW [On/Off]	Indicates condition of ignition switch ON position.
DOOR SW-DR [On/Off]	Indicates condition of front door switch LH.
DOOR SW-AS [On/Off]	Indicates condition of front door switch RH.

ACTIVE TEST

Test Item	Description
RETAINED PWR	This test is able to check retained power operation [Off/On].

WORK SUPPORT

Support Item	Setting		Description
	RETAINED PWR SET	MODE3	
MODE2		OFF	
MODE1*		45 sec	

*: Initial setting

SIGNAL BUFFER

SIGNAL BUFFER : CONSULT Function (BCM - SIGNAL BUFFER)

INFOID:000000008792593

DATA MONITOR

Monitor Item [Unit]	Description
OIL PRESS SW [On/Off]	Indicates condition of oil pressure switch signal received from IPDM E/R on CAN communication line.

ACTIVE TEST

Test Item	Description
OIL PRESSURE SW	This test is able to check the oil pressure gauge operation [Off/On].

AIR PRESSURE MONITOR

A
B
C
D
E
F
G
H
I
J
K
L
N
O
P

BCS

DIAGNOSIS SYSTEM (BCM)

< SYSTEM DESCRIPTION >

AIR PRESSURE MONITOR : CONSULT Function (BCM - AIR PRESSURE MONITOR)

INFOID:000000008792594

NOTE:

The Signal Tech II Tool (J-50190) can be used to perform the following functions. Refer to the Signal Tech II User Guide for additional information.

- Activate and display TPMS transmitter IDs
- Display tire pressure reported by the TPMS transmitter
- Read TPMS DTCs
- Register TPMS transmitter IDs

SELF DIAGNOSTIC RESULT

NOTE:

Before performing Self Diagnostic Result, be sure to register the ID, or else the actual malfunction may be different from that displayed on CONSULT.

Refer to [BCS-41, "DTC Index"](#).

DATA MONITOR

Monitor Item	Condition	Specification
VEHICLE SPEED	Drive vehicle.	Vehicle speed (km/h or mph).
AIR PRESS FL	• Drive vehicle for a few minutes. or • Ignition switch ON and activation tool is transmitting activation signals.	Tire pressure (kPa, kg/cm ² or psi).
AIR PRESS FR		
AIR PRESS RR		
AIR PRESS RL		
ID REGST FL1	Ignition switch ON.	Registration ID: Green. No registration: Red.
ID REGST FR1		
ID REGST RR1		
ID REGST RL1		
WARNING LAMP	Ignition switch ON.	Low tire pressure warning lamp on: ON. Low tire pressure warning lamp off: OFF.
BUZZER	Ignition switch ON.	Buzzer in combination meter on: ON. Buzzer in combination meter off: OFF.

ACTIVE TEST

Test Item	Description
WARNING LAMP	This test is able to check tire pressure warning lamp operation [Off/On].
ID REGIST WARNING	This test is able to check ID regist warning chime operation [Off/On].
FLAT TIRE WARNING	This test is able to check flat tire warning chime operation [Off/On].
HORN	This test is able to check horn operation [On].
FLASHER	This test is able to check turn signal lamp operation [Off/LH/RH].

WORK SUPPORT

Support Item	Description
ID REGIST	Refer to WT-6, "Description" .
ID READ	The registered ID number is displayed.

PANIC ALARM

PANIC ALARM : CONSULT Function (BCM - PANIC ALARM)

INFOID:000000008792595

ACTIVE TEST

DIAGNOSIS SYSTEM (BCM)

< SYSTEM DESCRIPTION >

Test Item	Description
HEAD LAMP (HI)	This test is able to check head lamp HI operation [On].
PANIC ALARM	This test is able to check panic alarm operation [On].

A

B

C

D

E

F

G

H

I

J

K

L

BCS

N

O

P

U1000 CAN COMM CIRCUIT

< DTC/CIRCUIT DIAGNOSIS >

DTC/CIRCUIT DIAGNOSIS

U1000 CAN COMM CIRCUIT

Description

INFOID:000000008792596

Refer to [LAN-58, "CAN Communication Signal Chart"](#).

DTC Logic

INFOID:000000008792597

DTC DETECTION LOGIC

DTC	CONSULT display description	DTC Detection Condition	Possible cause
U1000	CAN COMM CIRCUIT	When BCM cannot communicate CAN communication signal continuously for 2 seconds or more.	Any item (or items) of the following listed below is malfunctioning in CAN communication system. <ul style="list-style-type: none">• Transmission• Receiving (ECM)• Receiving (METER/M&A)• Receiving (TCM)• Receiving (IPDM E/R)

Diagnosis Procedure

INFOID:000000008792598

1. PERFORM SELF DIAGNOSTIC

1. Turn ignition switch ON and wait for 2 seconds or more.
2. Check "Self Diagnostic Result" of BCM.

Is "CAN COMM CIRCUIT" displayed?

- YES >> Refer to [LAN-14, "Trouble Diagnosis Flow Chart"](#).
NO >> Refer to [GI-49, "Intermittent Incident"](#).

POWER SUPPLY AND GROUND CIRCUIT

< DTC/CIRCUIT DIAGNOSIS >

POWER SUPPLY AND GROUND CIRCUIT

Diagnosis Procedure

INFOID:000000008792599

Regarding Wiring Diagram information, refer to [BCS-43. "Wiring Diagram"](#).

1. CHECK FUSES AND FUSIBLE LINK

Check that the following fuses and fusible link are not blown.

Terminal No.	Signal name	Fuses and fusible link No.
57	Battery power supply	21 (10A)
70		G (50A)
11	Ignition ACC or ON	4 (10A)
38	Ignition ON or START	1 (10A)

Is the fuse blown?

YES >> Replace the blown fuse or fusible link after repairing the affected circuit.

NO >> GO TO 2

2. CHECK POWER SUPPLY CIRCUIT

1. Turn ignition switch OFF.
2. Disconnect BCM.
3. Check voltage between BCM harness connector and ground.

Connector	Terminals		Power source	Condition	Voltage (V) (Approx.)
	(+)	(-)			
M18	11	Ground	ACC power supply	Ignition switch ACC or ON	Battery voltage
	38	Ground	Ignition power supply	Ignition switch ON or START	Battery voltage
M20	57	Ground	Battery power supply	Ignition switch OFF	Battery voltage
	70	Ground	Battery power supply	Ignition switch OFF	Battery voltage

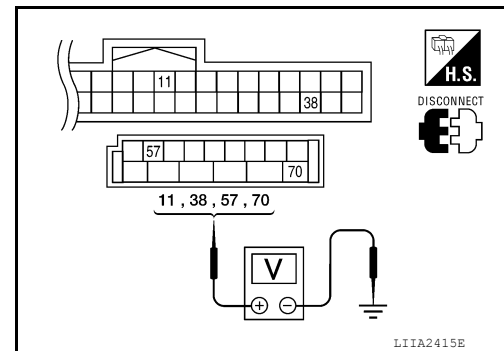

Is the measurement value normal?

YES >> GO TO 3

NO >> Repair or replace harness.

3. CHECK GROUND CIRCUIT

A
B
C
D
E
F
G
H
I
J
K
L
N
O
P

BCS

POWER SUPPLY AND GROUND CIRCUIT

< DTC/CIRCUIT DIAGNOSIS >

Check continuity between BCM harness connector and ground.

BCM		Ground	Continuity
Connector	Terminal		
M20	67		Yes

Does continuity exist?

- YES >> Inspection End.
- NO >> Repair or replace harness.

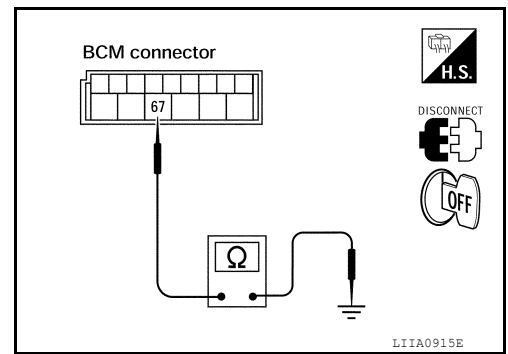

COMBINATION SWITCH INPUT CIRCUIT

< DTC/CIRCUIT DIAGNOSIS >

COMBINATION SWITCH INPUT CIRCUIT

Diagnosis Procedure

INFOID:000000008792600

Regarding Wiring Diagram information, refer to [BCS-43. "Wiring Diagram"](#).

1. CHECK INPUT 1 - 5 SYSTEM CIRCUIT FOR OPEN

1. Turn ignition switch OFF.
2. Disconnect BCM and combination switch.
3. Check continuity between BCM harness connector and combination switch harness connector.

System	BCM		Combination switch		Continuity
	Connector	Terminal	Connector	Terminal	
INPUT 1	M18 (A)	36	M28 (B)	1	Yes
INPUT 2		35		2	
INPUT 3		34		3	
INPUT 4		33		4	
INPUT 5		32		5	

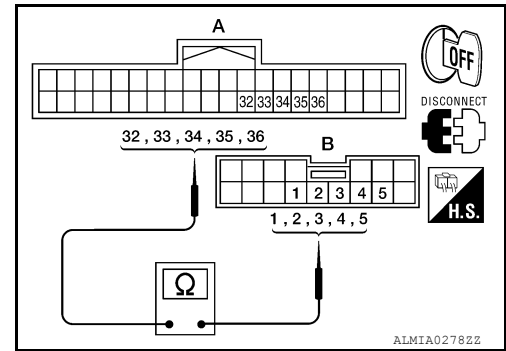

Does continuity exist?

- YES >> GO TO 2
 NO >> Repair or replace harness.

2. CHECK INPUT 1 - 5 SYSTEM CIRCUIT FOR SHORT

Check for continuity between BCM harness connector and ground.

System	BCM		Ground	Continuity
	Connector	Terminal		
INPUT 1	M18	36	Ground	No
INPUT 2		35		
INPUT 3		34		
INPUT 4		33		
INPUT 5		32		

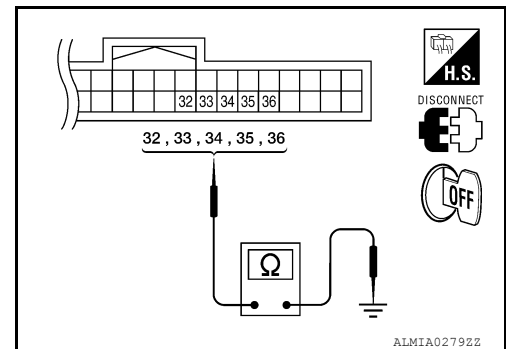

Does continuity exist?

- YES >> Repair or replace harness.
 NO >> GO TO 3

3. CHECK COMBINATION SWITCH

Check combination switch. Refer to [BCS-47. "Symptom Table"](#).

Is the check result normal?

- YES >> Replace BCM. Refer to [BCS-49. "Removal and Installation"](#).
 NO >> Replace combination switch (applicable parts). Refer to [EXL-147. "Removal and Installation"](#).

Special Repair Requirement

INFOID:000000008792601

1. ADDITIONAL SERVICE WHEN REPLACING BCM

>> Refer to [BCS-3. "ADDITIONAL SERVICE WHEN REPLACING CONTROL UNIT \(BCM\) : Description"](#).

COMBINATION SWITCH OUTPUT CIRCUIT

< DTC/CIRCUIT DIAGNOSIS >

COMBINATION SWITCH OUTPUT CIRCUIT

Diagnosis Procedure

INFOID:000000008792602

Regarding Wiring Diagram information, refer to [BCS-43. "Wiring Diagram"](#).

1. CHECK OUTPUT 1 - 5 SYSTEM CIRCUIT FOR OPEN

1. Turn ignition switch OFF.
2. Disconnect BCM and combination switch.
3. Check continuity between BCM harness connector and combination switch harness connector.

System	BCM		Combination switch		Continuity
	Connector	Terminal	Connector	Terminal	
OUTPUT 1	M18 (A)	6	M28 (B)	6	Yes
OUTPUT 2		5		7	
OUTPUT 3		4		10	
OUTPUT 4		3		9	
OUTPUT 5		2		8	

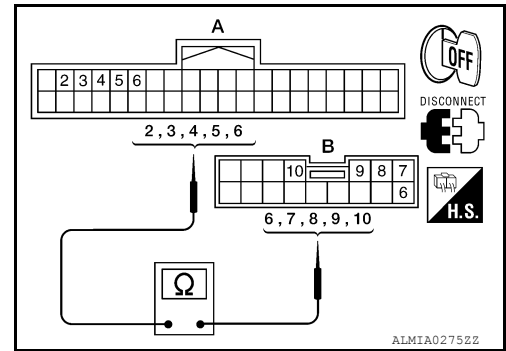

Does continuity exist?

- YES >> GO TO 2
 NO >> Repair or replace harness.

2. CHECK OUTPUT 1 - 5 SYSTEM CIRCUIT FOR SHORT

Check for continuity between BCM harness connector and ground.

System	BCM		Continuity
	Connector	Terminal	
OUTPUT 1	M18	6	No
OUTPUT 2		5	
OUTPUT 3		4	
OUTPUT 4		3	
OUTPUT 5		2	

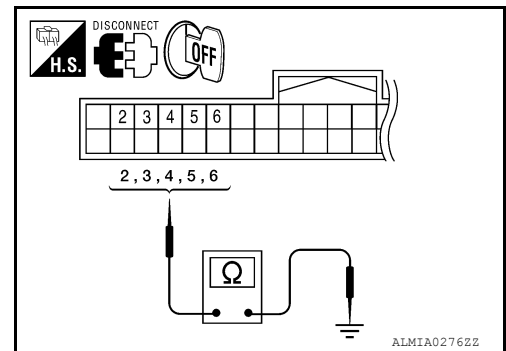

Does continuity exist?

- YES >> Repair or replace harness.
 NO >> GO TO 3

3. CHECK BCM INPUT VOLTAGE

1. Connect BCM.
2. Turn ignition switch ON.
3. Check voltage between BCM harness connector and ground.

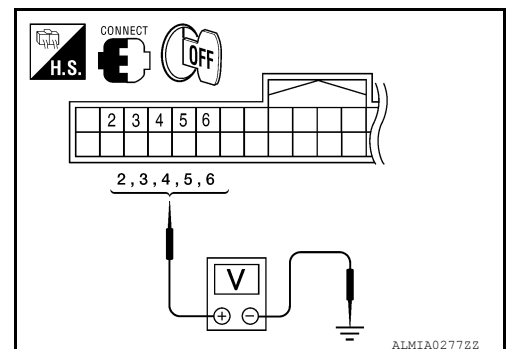

COMBINATION SWITCH OUTPUT CIRCUIT

< DTC/CIRCUIT DIAGNOSIS >

System	Terminals		Voltage (Approx.)
	(+)	(-)	
	BCM		
	Connector	Terminal	
INPUT 1	M18	6	Ground
INPUT 2		5	
INPUT 3		4	
INPUT 4		3	
INPUT 5		2	

Is the measurement value normal?

YES >> GO TO 4

NO >> Replace BCM. Refer to [BCS-49, "Removal and Installation"](#).

4. CHECK COMBINATION SWITCH

Check combination switch. Refer to [BCS-47, "Symptom Table"](#).

Is the check result normal?

YES >> Replace BCM. Refer to [BCS-49, "Removal and Installation"](#).

NO >> Replace the combination switch (applicable parts). Refer to [EXL-147, "Removal and Installation"](#).

Special Repair Requirement

INFOID:000000008792603

1. ADDITIONAL SERVICE WHEN REPLACING BCM

>> Refer to [BCS-3, "ADDITIONAL SERVICE WHEN REPLACING CONTROL UNIT \(BCM\) : Description"](#).

A
B
C
D
E
F
G
H
I
J
K
L

BCS

N
O
P

BCM (BODY CONTROL MODULE)

< ECU DIAGNOSIS INFORMATION >

ECU DIAGNOSIS INFORMATION

BCM (BODY CONTROL MODULE)

Reference Value

INFOID:000000008792604

NOTE:

The Signal Tech II Tool (J-50190) can be used to perform the following functions. Refer to the Signal Tech II User Guide for additional information.

- Activate and display TPMS transmitter IDs
- Display tire pressure reported by the TPMS transmitter
- Read TPMS DTCs
- Register TPMS transmitter IDs
- Test remote keyless entry keyfob relative signal strength

VALUES ON THE DIAGNOSIS TOOL

Monitor Item	Condition	Value/Status
ACC ON SW	Ignition switch OFF or ON	Off
	Ignition switch ACC	On
AIR COND SW	A/C switch OFF	Off
	A/C switch ON	On
AIR PRESS FL	Front left tire air pressure value	kPa, kg/cm ² , psi
AIR PRESS FR	Front right tire air pressure value	kPa, kg/cm ² , psi
AIR PRESS RL	Rear left tire air pressure value	kPa, kg/cm ² , psi
AIR PRESS RR	Rear right tire air pressure value	kPa, kg/cm ² , psi
BRAKE SW	Brake pedal released	Off
	Brake pedal applied	On
BUCKLE SW	Seat belt buckle unfastened	Off
	Seat belt buckle fastened	On
BUZZER	Buzzer in combination meter OFF	Off
	Buzzer in combination meter ON	On
CARGO LAMP SW	Cargo lamp switch OFF	Off
	Cargo lamp switch ON	On
CDL LOCK SW	Door lock/unlock switch does not operate	Off
	Press door lock/unlock switch to the LOCK side	On
CDL UNLOCK SW	Door lock/unlock switch does not operate	Off
	Press door lock/unlock switch to the UNLOCK side	On
DOOR SW-AS	Front door RH closed	Off
	Front door RH opened	On
DOOR SW-DR	Front door LH closed	Off
	Front door LH opened	On
DOOR SW-RL	Rear door LH closed	Off
	Rear door LH opened	On
DOOR SW-RR	Rear door RH closed	Off
	Rear door RH opened	On
FAN ON SIG	Blower motor fan switch OFF	Off
	Blower motor fan switch ON	On

BCM (BODY CONTROL MODULE)

< ECU DIAGNOSIS INFORMATION >

Monitor Item	Condition	Value/Status	
FR FOG SW	Front fog lamp switch OFF	Off	A
	Front fog lamp switch ON	On	
FR WASHER SW	Front washer switch OFF	Off	B
	Front washer switch ON	On	
FR WIPER LOW	Front wiper switch OFF	Off	C
	Front wiper switch LO	On	
FR WIPER HI	Front wiper switch OFF	Off	D
	Front wiper switch HI	On	
FR WIPER INT	Front wiper switch OFF	Off	E
	Front wiper switch INT	On	
FR WIPER STOP	Any position other than front wiper stop position	Off	
	Front wiper stop position	On	
HAZARD SW	When hazard switch is not pressed	Off	F
	When hazard switch is pressed	On	
HEAD LAMP SW 1	Headlamp switch OFF	Off	G
	Headlamp switch 1st	On	
HEAD LAMP SW 2	Headlamp switch OFF	Off	H
	Headlamp switch 1st	On	
HI BEAM SW	High beam switch OFF	Off	I
	High beam switch HI	On	
ID REGST FL1	ID registration of front left tire incomplete	YET	J
	ID registration of front left tire complete	DONE	
ID REGST FR1	ID registration of front right tire incomplete	YET	K
	ID registration of front right tire complete	DONE	
ID REGST RL1	ID registration of rear left tire incomplete	YET	L
	ID registration of rear left tire complete	DONE	
ID REGST RR1	ID registration of rear right tire incomplete	YET	
	ID registration of rear right tire complete	DONE	
IGN ON SW	Ignition switch OFF or ACC	Off	
	Ignition switch ON	On	
IGN SW CAN	Ignition switch OFF or ACC	Off	BCS
	Ignition switch ON	On	
INT VOLUME	Wiper intermittent dial is in a dial position 1 - 7	1 - 7	
KEY CYL LK-SW	Door key cylinder LOCK position	Off	N
	Door key cylinder other than LOCK position	On	
KEY CYL UN-SW	Door key cylinder UNLOCK position	Off	O
	Door key cylinder other than UNLOCK position	On	
KEY ON SW	Mechanical key is removed from key cylinder	Off	P
	Mechanical key is inserted to key cylinder	On	
KEYLESS LOCK	LOCK button of key fob is not pressed	Off	
	LOCK button of key fob is pressed	On	
KEYLESS PANIC	PANIC button of key fob is not pressed	Off	
	PANIC button of key fob is pressed	On	

BCM (BODY CONTROL MODULE)

< ECU DIAGNOSIS INFORMATION >

Monitor Item	Condition	Value/Status
KEYLESS UNLOCK	UNLOCK button of key fob is not pressed	Off
	UNLOCK button of key fob is pressed	On
LIGHT SW 1ST	Lighting switch OFF	Off
	Lighting switch 1st	On
OIL PRESS SW	<ul style="list-style-type: none">Ignition switch OFF or ACCEngine running	Off
	Ignition switch ON	On
PASSING SW	Other than lighting switch PASS	Off
	Lighting switch PASS	On
REAR DEF SW	Rear window defogger switch OFF	Off
	Rear window defogger switch ON	On
TURN SIGNAL L	Turn signal switch OFF	Off
	Turn signal switch LH	On
TURN SIGNAL R	Turn signal switch OFF	Off
	Turn signal switch RH	On
VEHICLE SPEED	While driving	Equivalent to speedometer reading
WARNING LAMP	Low tire pressure warning lamp in combination meter OFF	Off
	Low tire pressure warning lamp in combination meter ON	On

BCM (BODY CONTROL MODULE)

< ECU DIAGNOSIS INFORMATION >

Terminal Layout

INFOID:000000008792605

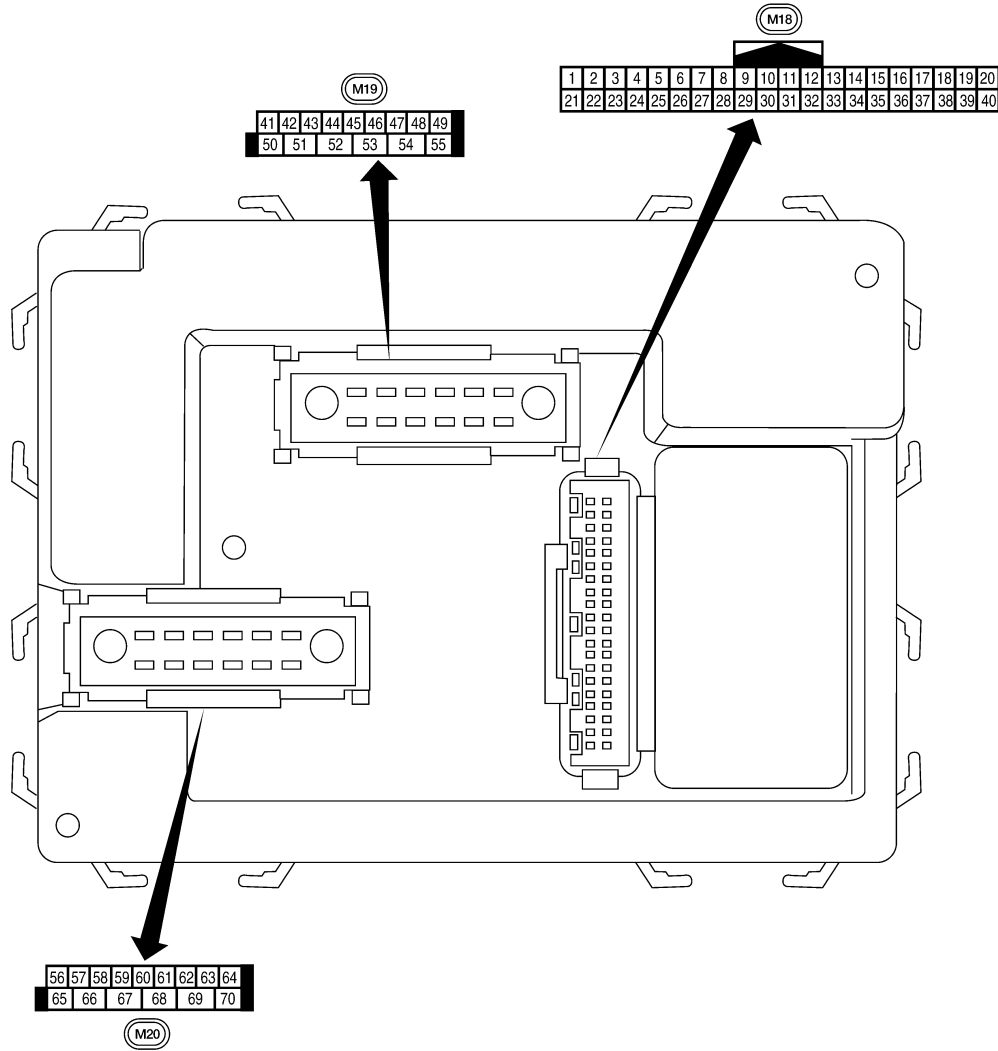

A
B
C
D
E
F
G
H
I
J
K
L

BCS



Physical Values

LIIA2443E

INFOID:000000008792606

BCM (BODY CONTROL MODULE)

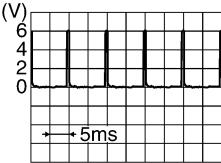
< ECU DIAGNOSIS INFORMATION >

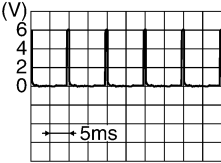
Terminal	Wire color	Item	Signal input/output	Measuring condition		Reference value or waveform (Approx.)
				Ignition switch	Operation or condition	
1	BR	Ignition keyhole illumination	Output	OFF	Door is locked (SW OFF)	Battery voltage
					Door is unlocked (SW ON)	0V
2	P	Combination switch input 5	Input	ON	Lighting, turn, wiper OFF Wiper dial position 4	 <p style="text-align: right; font-size: small;">SKIA5291E</p>
3	SB	Combination switch input 4	Input	ON	Lighting, turn, wiper OFF Wiper dial position 4	 <p style="text-align: right; font-size: small;">SKIA5292E</p>
4	V	Combination switch input 3	Input	ON	Lighting, turn, wiper OFF Wiper dial position 4	 <p style="text-align: right; font-size: small;">SKIA5291E</p>
5	L	Combination switch input 2	Input	ON	Lighting, turn, wiper OFF Wiper dial position 4	 <p style="text-align: right; font-size: small;">SKIA5292E</p>
6	R	Combination switch input 1				
7	GR	Front door lock assembly LH (key cylinder switch) unlock	Input	OFF	ON (open, 2nd turn)	Momentary 1.5V
8	SB	Front door lock assembly LH (key cylinder switch) lock			OFF (closed)	0V
			On (open)	Momentary 1.5V		
9	LG	Brake sw	Input	OFF	OFF (brake pedal is not depressed)	0V
					ON (brake pedal is depressed)	Battery voltage
11	G/B	Ignition switch (ACC or ON)	Input	ACC or ON	Ignition switch ACC or ON	Battery voltage
12	LG	Front door switch RH (All)	Input	OFF	ON (open)	0V
		Rear door switch upper RH (King Cab)			OFF (closed)	Battery voltage
		Rear door switch lower RH (King Cab)				

BCM (BODY CONTROL MODULE)

< ECU DIAGNOSIS INFORMATION >

Terminal	Wire color	Item	Signal input/output	Measuring condition		Reference value or waveform (Approx.)
				Ignition switch	Operation or condition	
13	L	Rear door switch RH (Crew Cab)	Input	OFF	ON (open)	0V
					OFF (closed)	Battery voltage
15	W	Tire pressure warning check connector	Input	OFF	—	5V
18	BR	Remote keyless entry receiver (Ground)	Output	OFF	—	0V
19	V	Remote keyless entry receiver (power supply)	Output	OFF	Ignition switch OFF	<p style="text-align: right; font-size: small;">LIIA1893E</p>
20	G	Remote keyless entry receiver signal (Signal)	Input	OFF	Stand-by (keyfob buttons released)	<p style="text-align: right; font-size: small;">LIIA1894E</p>
					When remote keyless entry receiver receives signal from keyfob (keyfob buttons pressed)	<p style="text-align: right; font-size: small;">LIIA1895E</p>
21	GR	NATS antenna amp.	Input	OFF → ON	Ignition switch (OFF → ON)	Just after turning ignition switch ON: Pointer of tester should move.
23	G	Security indicator lamp	Output	OFF	Goes OFF → illuminates (Every 2.4 seconds)	Battery voltage → 0V
25	BR	NATS antenna amp.	Input	OFF → ON	Ignition switch (OFF → ON)	Just after turning ignition switch ON: Pointer of tester should move.
27	W	Compressor ON signal	Input	ON	A/C switch OFF	5V
					A/C switch ON	0V
28	R	Front blower monitor	Input	ON	Front blower motor OFF	Battery voltage
					Front blower motor ON	0V
29	G	Hazard switch	Input	OFF	ON	0V
					OFF	5V
31	GR	Cargo lamp switch	Input	OFF	ON	0V
					OFF	Battery voltage

A
B
C
D
E
F
G
H
I
J
K
L
N
O
P

BCS

BCM (BODY CONTROL MODULE)

< ECU DIAGNOSIS INFORMATION >

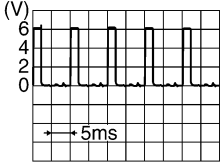
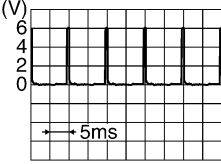
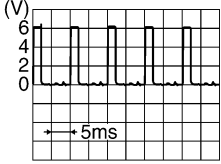
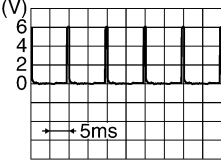
Terminal	Wire color	Item	Signal input/output	Measuring condition		Reference value or waveform (Approx.)
				Ignition switch	Operation or condition	
32	O	Combination switch output 5	Output	ON	Lighting, turn, wiper OFF Wiper dial position 4	 <p style="text-align: right; font-size: small;">SKIA5291E</p>
33	GR	Combination switch output 4	Output	ON	Lighting, turn, wiper OFF Wiper dial position 4	 <p style="text-align: right; font-size: small;">SKIA5292E</p>
34	G	Combination switch output 3	Output	ON	Lighting, turn, wiper OFF Wiper dial position 4	 <p style="text-align: right; font-size: small;">SKIA5291E</p>
35	BR	Combination switch output 2	Output	ON	Lighting, turn, wiper OFF Wiper dial position 4	 <p style="text-align: right; font-size: small;">SKIA5292E</p>
36	LG	Combination switch output 1				
37	B	Key switch	Input	OFF	Key inserted	Battery voltage
					Key removed	0V
38	W/R	Ignition switch (ON)	Input	ON	—	Battery voltage
39	L	CAN-H	—	—	—	—
40	P	CAN-L	—	—	—	—
41	Y	Rear window defogger switch	Input	ON	Rear window defogger switch ON	0V
					Rear window defogger switch OFF	5V
45	V	Lock switch	Input	OFF	ON (lock)	0V
					OFF	Battery voltage
46	LG	Unlock switch	Input	OFF	ON (unlock)	0V
					OFF	Battery voltage
47	GR	Front door switch LH (All)	Input	OFF	ON (open)	0V
		Rear door switch upper LH (King Cab)			OFF (closed)	Battery voltage
		Rear door switch lower LH (King Cab)				

BCM (BODY CONTROL MODULE)

< ECU DIAGNOSIS INFORMATION >

Terminal	Wire color	Item	Signal input/output	Measuring condition		Reference value or waveform (Approx.)	
				Ignition switch	Operation or condition		
48	P	Rear door switch LH (Crew Cab)	Input	OFF	ON (open)	0V	
					OFF (closed)	Battery voltage	
50	P	Cargo lamp	Output	OFF	Any door open (ON)	0V	
					All doors closed (OFF)	Battery voltage	
51	O	Trailer turn signal (right)	Output	ON	Turn right ON	<p style="text-align: right; font-size: small;">SKIA3009J</p>	
52	LG	Trailer turn signal (left)	Output	ON	Turn left ON	<p style="text-align: right; font-size: small;">SKIA3009J</p>	
56	R/Y	Battery saver output	Output	OFF	15 minutes after ignition switch is turned OFF	0V	
				ON	—	Battery voltage	
57	R/Y	Battery power supply	Input	—	—	Battery voltage	
58	W	Optical sensor	Input	ON	When optical sensor is illuminated	3.1V or more	
					When optical sensor is not illuminated	0.6V or less	
59	GR	Front door lock assembly LH (unlock)	Output	OFF	OFF (neutral)	0V	
					ON (unlock)	Battery voltage	
60	LG	Turn signal (left)	Output	ON	Turn left ON	<p style="text-align: right; font-size: small;">SKIA3009J</p>	
61	G	Turn signal (right)	Output	ON	Turn right ON	<p style="text-align: right; font-size: small;">SKIA3009J</p>	
63	BR	Interior room/map lamp	Output	OFF	Any door switch	ON (open)	0V
					OFF (closed)	Battery voltage	
65	V	All door lock actuators (lock)	Output	OFF	OFF (neutral)	0V	
					ON (lock)	Battery voltage	

A
B
C
D
E
F
G
H
I
J
K
L
N
O
P

BCS

BCM (BODY CONTROL MODULE)

< ECU DIAGNOSIS INFORMATION >

Terminal	Wire color	Item	Signal input/output	Measuring condition		Reference value or waveform (Approx.)
				Ignition switch	Operation or condition	
66	L	Front door lock actuator RH, rear door lock actuators LH/RH (unlock)	Output	OFF	OFF (neutral)	0V
					ON (unlock)	Battery voltage
67	B	Ground	Input	ON	—	0V
68 ¹	O	Power window power supply (RAP)	Output	—	Ignition switch ON	Battery voltage
					Within 45 seconds after ignition switch OFF	Battery voltage
					More than 45 seconds after ignition switch OFF	0V
					When front door LH or RH is open or power window timer operates	0V
68 ²	SB	Power window power supply (RAP)	Output	—	Ignition switch ON	Battery voltage
					Within 45 seconds after ignition switch OFF	Battery voltage
					More than 45 seconds after ignition switch OFF	0V
					When front door LH or RH is open or power window timer operates	0V
69	P	Power window power supply (BAT)	Output	OFF	—	Battery voltage
70	W	Battery power supply	Input	OFF	—	Battery voltage

1: King cab (with power door lock system)

2: Crew cab (without power door lock system)

Fail Safe

INFOID:000000008792607

Fail-safe index

BCM performs fail-safe control when any DTC listed below is detected.

Display contents of CONSULT	Fail-safe	Cancellation
U1000: CAN COMM CIRCUIT	Inhibit engine cranking	When the BCM re-establishes communication with the other modules.

DTC Inspection Priority Chart

INFOID:000000008792608

If some DTCs are displayed at the same time, perform inspections one by one based on the following priority chart.

Priority	DTC
1	<ul style="list-style-type: none"> U1000: CAN COMM CIRCUIT
2	<ul style="list-style-type: none"> B2190: NATS ANTENNA AMP B2191: DIFFERENCE OF KEY B2192: ID DISCORD BCM-ECM B2193: CHAIN OF BCM-ECM

BCM (BODY CONTROL MODULE)

< ECU DIAGNOSIS INFORMATION >

Priority	DTC	
3	<ul style="list-style-type: none"> • C1729: VHCL SPEED SIG ERR • C1735: IGNITION SIGNAL 	A
4	<ul style="list-style-type: none"> • C1704: LOW PRESSURE FL • C1705: LOW PRESSURE FR • C1706: LOW PRESSURE RR • C1707: LOW PRESSURE RL • C1708: [NO DATA] FL • C1709: [NO DATA] FR • C1710: [NO DATA] RR • C1711: [NO DATA] RL • C1712: [CHECKSUM ERR] FL • C1713: [CHECKSUM ERR] FR • C1714: [CHECKSUM ERR] RR • C1715: [CHECKSUM ERR] RL • C1716: [PRESSDATA ERR] FL • C1717: [PRESSDATA ERR] FR • C1718: [PRESSDATA ERR] RR • C1719: [PRESSDATA ERR] RL • C1720: [CODE ERR] FL • C1721: [CODE ERR] FR • C1722: [CODE ERR] RR • C1723: [CODE ERR] RL • C1724: [BATT VOLT LOW] FL • C1725: [BATT VOLT LOW] FR • C1726: [BATT VOLT LOW] RR • C1727: [BATT VOLT LOW] RL 	B C D E F G H

DTC Index

INFOID:000000008792609

NOTE:

- Details of time display
- CRNT: Displays when there is a malfunction now or after returning to the normal condition until turning ignition switch OFF → ON again.
- 1 - 39: Displayed if any previous malfunction is present when current condition is normal. It increases like 1 → 2 → 3...38 → 39 after returning to the normal condition whenever ignition switch OFF → ON. The counter remains at 39 even if the number of cycles exceeds it. It is counted from 1 again when turning ignition switch OFF → ON after returning to the normal condition if the malfunction is detected again.

CONSULT display	Fail-safe	Low tire pressure warning lamp ON	Reference page
No DTC is detected. further testing may be required.	—	—	—
U1000: CAN COMM CIRCUIT	—	—	BCS-26
B2190: NATS ANTENA AMP	—	—	SEC-18
B2191: DIFFERENCE OF KEY	—	—	SEC-21
B2192: ID DISCORD BCM-ECM	—	—	SEC-22
B2193: CHAIN OF BCM-ECM	—	—	SEC-24
C1708: [NO DATA] FL	—	X	WT-15
C1709: [NO DATA] FR	—	X	WT-15
C1710: [NO DATA] RR	—	X	WT-15
C1711: [NO DATA] RL	—	X	WT-15
C1712: [CHECKSUM ERR] FL	—	X	WT-17
C1713: [CHECKSUM ERR] FR	—	X	WT-17
C1714: [CHECKSUM ERR] RR	—	X	WT-17
C1715: [CHECKSUM ERR] RL	—	X	WT-17

BCM (BODY CONTROL MODULE)

< ECU DIAGNOSIS INFORMATION >

CONSULT display	Fail-safe	Low tire pressure warning lamp ON	Reference page
C1716: [PRESSDATA ERR] FL	—	X	WT-19
C1717: [PRESSDATA ERR] FR	—	X	WT-19
C1718: [PRESSDATA ERR] RR	—	X	WT-19
C1719: [PRESSDATA ERR] RL	—	X	WT-19
C1720: [CODE ERR] FL	—	X	WT-17
C1721: [CODE ERR] FR	—	X	WT-17
C1722: [CODE ERR] RR	—	X	WT-17
C1723: [CODE ERR] RL	—	X	WT-17
C1724: [BATT VOLT LOW] FL	—	X	WT-17
C1725: [BATT VOLT LOW] FR	—	X	WT-17
C1726: [BATT VOLT LOW] RR	—	X	WT-17
C1727: [BATT VOLT LOW] RL	—	X	WT-17
C1729: VHCL SPEED SIG ERR	—	X	WT-21
C1735: IGNITION SIGNAL	—	X	WT-22

BCM (BODY CONTROL MODULE)

< WIRING DIAGRAM >

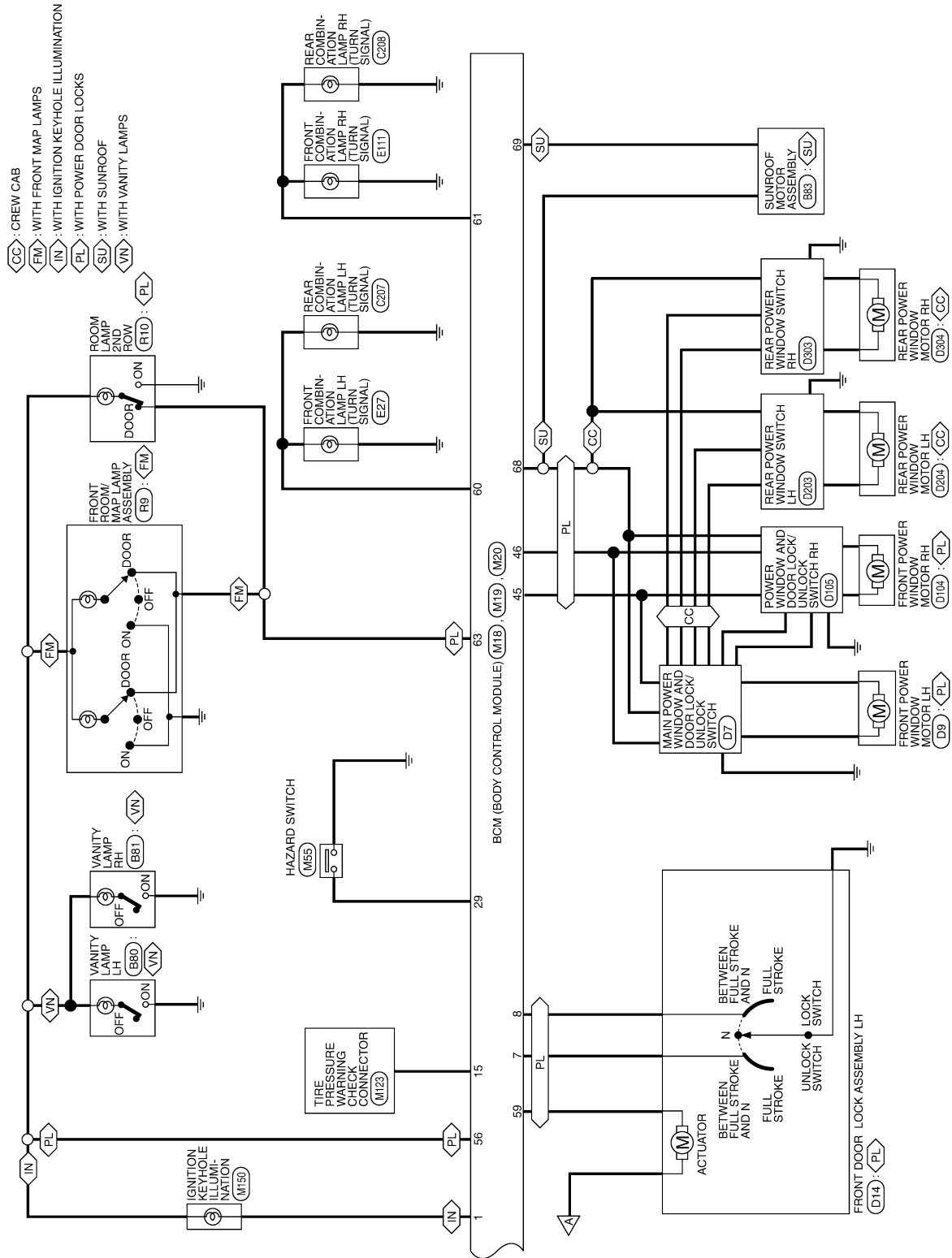

ABMWA1864GB

BCM (BODY CONTROL MODULE)

< WIRING DIAGRAM >

BCM (BODY CONTROL MODULE) CONNECTORS

Connector No.	M18
Connector Name	BCM (BODY CONTROL MODULE)
Connector Color	WHITE



1	2	3	4	5	6	7	8	9	10	11	12	13	14	15	16	17	18	19	20
21	22	23	24	25	26	27	28	29	30	31	32	33	34	35	36	37	38	39	40

Terminal No.	Color of Wire	Signal Name
1	BR	KEY RING OUTPUT
2	P	INPUT 5
3	SB	INPUT 4
4	V	INPUT 3
5	L	INPUT 2
6	R	INPUT 1
7	GR	KEY CYLINDER UNLOCK SW
8	SB	KEY CYLINDER LOCK SW
9	LG	BRAKE SW
10	-	-
11	G/B	ACC SW
12	LG	DOOR SW (AS)
13	L	DOOR SW (RR)
14	-	-
15	W	TPMS MODE TRIGGER SW
16	-	-
17	-	-
18	BR	KEYLESS & AUTO LIGHT SENSOR GND
19	V	KEYLESS TUNER POWER SUPPLY OUTPUT

Terminal No.	Color of Wire	Signal Name
20	G	KEYLESS TUNER SIGNAL
21	GR	IMMOBILIZER ANTENNA SIGNAL (CLOCK)
22	-	-
23	G	SECURITY INDICATOR OUTPUT
24	-	-
25	BR	IMMOBILIZER ANTENNA SIGNAL (RX, TX)
26	-	-
27	W	AIRCON SW
28	R	BLOWER FAN SW
29	G	HAZARD SW
30	-	-
31	GR	CARGO LAMP SW
32	O	OUTPUT 5
33	GR	OUTPUT 4
34	G	OUTPUT 3
35	BR	OUTPUT 2
36	LG	OUTPUT 1
37	B	KEY SW
38	W/R	IGN SW
39	L	CAN-H
40	P	CAN-L

Connector No.	M19
Connector Name	BCM (BODY CONTROL MODULE)
Connector Color	WHITE



41	42	43	44	45	46	47	48	49
50	51	52	53	54	55			

Terminal No.	Color of Wire	Signal Name
41	Y	REAR DEFOGGER SW
42	-	-
43	-	-
44	-	-
45	V	CDL LOCK SW
46	LG	CDL UNLOCK SW
47	GR	DOOR SW (DR)
48	P	DOOR SW (RL)
49	-	-
50	P	CARGO LAMP OUTPUT
51	O	TRAILER FLASHER OUTPUT (RIGHT)
52	LG	TRAILER FLASHER OUTPUT (LEFT)
53	-	-
54	-	-
55	-	-

A
B
C
D
E
F
G
H
I
J
K
L
M
N
O
P



BCM (BODY CONTROL MODULE)

< WIRING DIAGRAM >

Connector No.	M28
Connector Name	COMBINATION SWITCH
Connector Color	WHITE

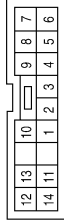

Terminal No.	Color of Wire	Signal Name
1	LG	-
2	BR	-
3	G	-
4	GR	-
5	O	-
6	R	-
7	L	-
8	P	-
9	SB	-
10	V	-
11	O	-
12	B	-
13	L	-
14	W/G	-

Terminal No.	Color of Wire	Signal Name
65	V	DOOR LOCK OUTPUT (ALL)
66	L	DOOR UNLOCK OUTPUT (OTHER)
67	B	GND (POWER)
68	O	POWER WINDOW POWER SUPPLY OUTPUT (LINKED TO RAP) (WITH POWER DOOR LOCK SYSTEM)
68	SB	POWER WINDOW POWER SUPPLY OUTPUT (LINKED TO RAP) (CREW CAB WITHOUT POWER DOOR LOCK SYSTEM)
69	P	POWER WINDOW POWER SUPPLY OUTPUT (BAT)
70	W	BAT (F/L)

Connector No.	M20
Connector Name	BCM (BODY CONTROL MODULE)
Connector Color	BLACK

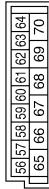

Terminal No.	Color of Wire	Signal Name
56	R/Y	BATTERY SAVER OUTPUT
57	R/Y	BAT (FUSE)
58	W	AUTO LIGHT SENSOR INPUT 2
59	GR	DOOR UNLOCK OUTPUT (DR)
60	LG	FLASHER OUTPUT (LEFT)
61	G	FLASHER OUTPUT (RIGHT)
62	-	-
63	BR	ROOM LAMP OUTPUT
64	-	-

ABMIA4364GB

COMBINATION SWITCH SYSTEM SYMPTOMS

< SYMPTOM DIAGNOSIS >

SYMPTOM DIAGNOSIS

COMBINATION SWITCH SYSTEM SYMPTOMS

Symptom Table

INFOID:000000008792611

1. Perform the data monitor of CONSULT to check for any malfunctioning item.
2. Check the malfunction combinations.

Malfunction item: x

Malfunction combination	Data monitor item													
	TURN SIGNAL R	TURN SIGNAL L	HI BEAM SW	HEADLAMP SW 1	HEADLAMP SW 2	TAIL LAMP SW	PASSING SW	AUTO LIGHT SW	FR FOG SW	FR WIPER HI	FR WIPER LOW	FR WIPER INT	FR WASHER SW	INT VOLUME
A	x	x									x		x	
B				x			x			x		x		
C			x		x									x
D						x		x						x
E									x					x
F										x				x
G													x	x
H								x			x	x		
I		x			x		x		x					
J	x		x	x		x								
K	All Items													
L	If only one item is detected or the item is not applicable to the combinations A to L													

3. Identify the malfunctioning part from the agreed combination and repair or replace the part.

Malfunction combination	Malfunctioning part	Repair or replace
A	Combination switch INPUT 1 circuit	Inspect the combination switch input circuit applicable to the malfunctioning part. Refer to BCS-29, "Diagnosis Procedure" .
B	Combination switch INPUT 2 circuit	
C	Combination switch INPUT 3 circuit	
D	Combination switch INPUT 4 circuit	
E	Combination switch INPUT 5 circuit	
F	Combination switch OUTPUT 1 circuit	Inspect the combination switch output circuit applicable to the malfunctioning part. Refer to BCS-30, "Diagnosis Procedure" .
G	Combination switch OUTPUT 2 circuit	
H	Combination switch OUTPUT 3 circuit	
I	Combination switch OUTPUT 4 circuit	
J	Combination switch OUTPUT 5 circuit	
K	BCM	Replace BCM. Refer to BCS-49, "Removal and Installation" .
L	Light and turn signal switch or front wiper and washer switch	Replace the switch that cannot be operated.

PRECAUTIONS

< PRECAUTION >

PRECAUTION

PRECAUTIONS

Precaution for Supplemental Restraint System (SRS) "AIR BAG" and "SEAT BELT PRE-TENSIONER"

INFOID:000000008792612

The Supplemental Restraint System such as "AIR BAG" and "SEAT BELT PRE-TENSIONER", used along with a front seat belt, helps to reduce the risk or severity of injury to the driver and front passenger for certain types of collision. This system includes seat belt switch inputs and dual stage front air bag modules. The SRS system uses the seat belt switches to determine the front air bag deployment, and may only deploy one front air bag, depending on the severity of a collision and whether the front occupants are belted or unbelted. Information necessary to service the system safely is included in the SR and SB section of this Service Manual.

WARNING:

- To avoid rendering the SRS inoperative, which could increase the risk of personal injury or death in the event of a collision which would result in air bag inflation, all maintenance must be performed by an authorized NISSAN/INFINITI dealer.
- Improper maintenance, including incorrect removal and installation of the SRS, can lead to personal injury caused by unintentional activation of the system. For removal of Spiral Cable and Air Bag Module, see the SR section.
- Do not use electrical test equipment on any circuit related to the SRS unless instructed to in this Service Manual. SRS wiring harnesses can be identified by yellow and/or orange harnesses or harness connectors.

PRECAUTIONS WHEN USING POWER TOOLS (AIR OR ELECTRIC) AND HAMMERS

WARNING:

- When working near the Airbag Diagnosis Sensor Unit or other Airbag System sensors with the Ignition ON or engine running, DO NOT use air or electric power tools or strike near the sensor(s) with a hammer. Heavy vibration could activate the sensor(s) and deploy the air bag(s), possibly causing serious injury.
- When using air or electric power tools or hammers, always switch the Ignition OFF, disconnect the battery, and wait at least 3 minutes before performing any service.

BCM (BODY CONTROL MODULE)

< REMOVAL AND INSTALLATION >

REMOVAL AND INSTALLATION

BCM (BODY CONTROL MODULE)

Removal and Installation

INFOID:000000008792613

REMOVAL

NOTE:

If possible, before removing BCM, retrieve current BCM configuration to use for reference when configuring brand-new BCM after installation. Refer to [BCS-3, "ADDITIONAL SERVICE WHEN REPLACING CONTROL UNIT \(BCM\) : Work Procedure"](#).

1. Disconnect the battery negative terminal. Refer to [PG-82, "Removal and Installation"](#).
2. Remove the instrument lower panel LH. Refer to [IP-18, "Removal and Installation"](#).
3. Remove the BCM screws and release the BCM.
4. Disconnect the harness connectors from BCM and remove.

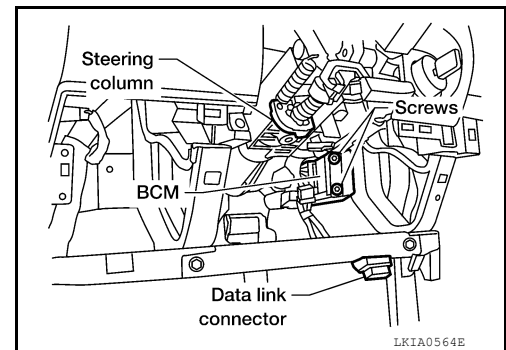

INSTALLATION

Installation is in the reverse order of removal.

- When replacing the BCM, it must be configured. Refer to [BCS-4, "CONFIGURATION \(BCM\) : Work Procedure"](#).
- When replacing the BCM, if equipped with NATS perform initialization of NATS system and registration of all NATS ignition key IDs. Refer to [BCS-4, "CONFIGURATION \(BCM\) : Work Procedure"](#).
- When replacing the BCM, perform ID registration procedure of low tire pressure warning system. Refer to [WT-5, "Preliminary Check"](#).
- When replacing the BCM, if equipped with remote keyless entry, register the remote keyless entry system keyfob ID codes. Refer to [BCS-3, "ADDITIONAL SERVICE WHEN REPLACING CONTROL UNIT \(BCM\) : Work Procedure"](#).
- When replacing the BCM, perform adjustment procedure for the steering angle sensor (if equipped). Refer to [BRC-12, "ADJUSTMENT OF STEERING ANGLE SENSOR NEUTRAL POSITION : Special Repair Requirement"](#) (TYPE 1) or [BRC-122, "ADJUSTMENT OF STEERING ANGLE SENSOR NEUTRAL POSITION : Special Repair Requirement"](#) (TYPE 2).

A
B
C
D
E
F
G
H
I
J
K
L
N
O
P

BCS